



宇 | 星 | 模 | 王

CREATIVE IDEA

百变创意

F488 超跑V8发动机
NO.F488 SUPERCAR V8 ENGINE

10130

2718 + Pcs/Pza

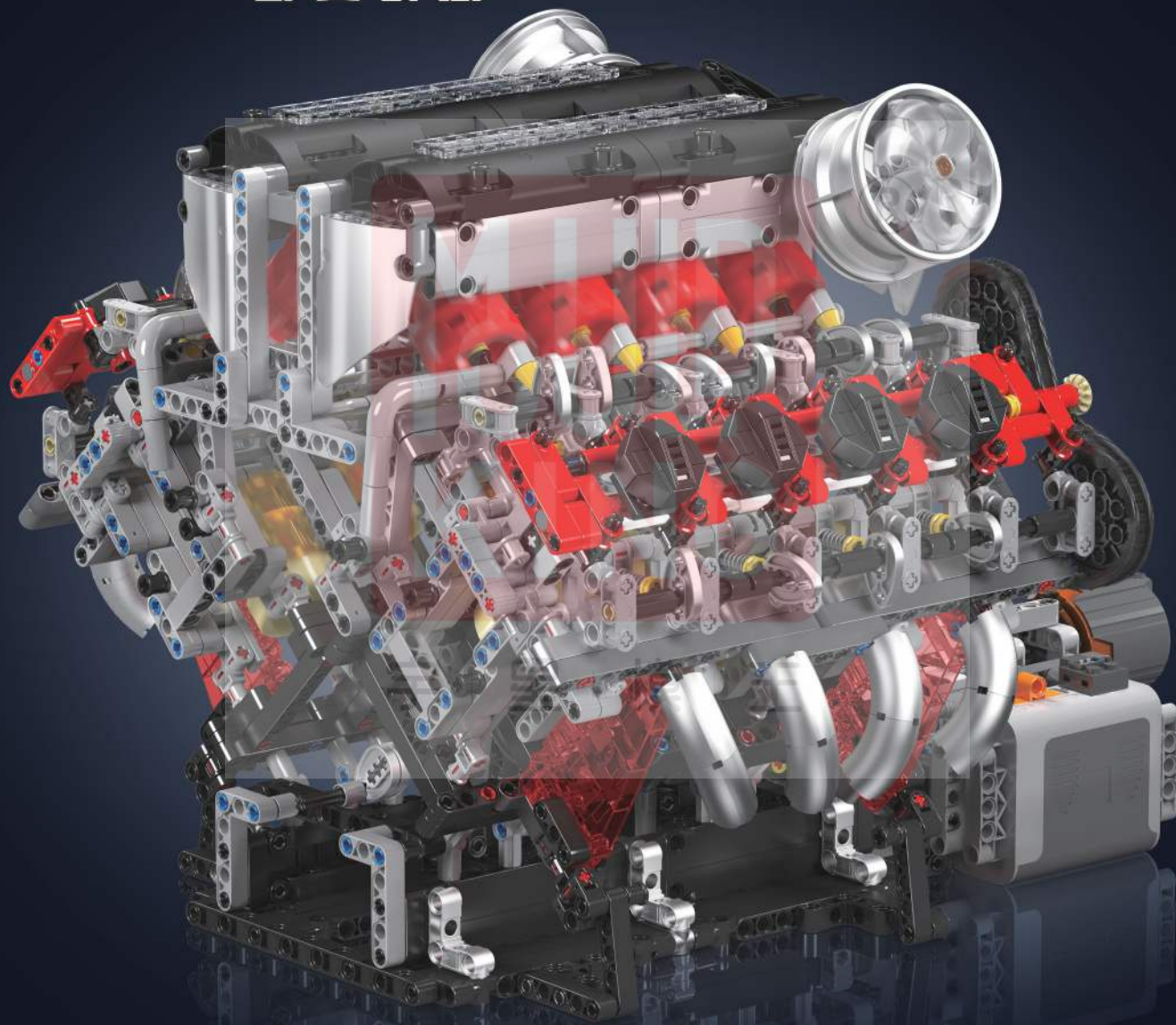



QR Code APP (APP二维码)
 QR-Code-App
 Application Code QR
 App Codice QR
 Aplicación de Código QR
 QRコードアプリ

Need the apple version 9.0 and above, the android version 5.0 and above.
 Erfordert iOS Version 9.0 oder höher, Android Version 5.0 oder höher.
 Nécessite la version 9.0 ou supérieure pour Apple, et la version 5.0 ou supérieure pour Android.
 Richiede la versione 9.0 o superiore per Apple, e la versione 5.0 o superiore per Android.
 Requiere versión 9.0 o superior para Apple, y versión 5.0 o superior para Android.
 Appleはバージョン9.0以上、Androidはバージョン5.0以上が必要です。

*This APP supports most of the mainstream Android models on the market, but due to the large number of Android models, different models of systems and hardware reasons, there may be some models do not supported, specific according to the actual test!

*Diese App unterstützt die meisten gängigen Android-Modelle auf dem Markt. Aufgrund der großen Anzahl von Android-Modellen und unterschiedlicher System- und Hardwarebedingungen kann es jedoch sein, dass einige Modelle nicht unterstützt werden. Die Kompatibilität hängt vom tatsächlichen Test ab!

*Cette application prend en charge la plupart des modèles Android populaires sur le marché, mais en raison du grand nombre de modèles Android, de différents systèmes de modèles et de raisons matérielles, certains modèles peuvent ne pas être pris en charge, selon le test réel !

*Questa app supporta la maggior parte dei modelli Android mainstream sul mercato, ma a causa del grande numero di modelli Android, diversi modelli di sistemi e motivi hardware, potrebbero esserci alcuni modelli che non sono supportati, specifici secondo il test effettivo!

*Esta aplicación es compatible con la mayoría de los modelos Android principales en el mercado, pero debido al gran número de modelos de Android, diferentes modelos de sistemas y razones de hardware, puede haber algunos modelos que no son compatibles, específicos según la prueba real!

*このアプリは市場に出ている主流のAndroidモデルのほとんどをサポートしていますが、Androidモデルの数が非常に多く、システムやハードウェアの違いにより、サポートされないモデルが存在する可能性があります。実際のテストによります！



广东宇星科技
 Mould King



产品资讯
 Product Information
 Produktinformation
 Information sur le produit
 Informazioni sul prodotto
 Información del producto
 製品情報

宇 | 星 ? 模 | 王

售后服务
 After-sales Service
 Kundendienst nach dem Kauf
 Service après-vente
 Servizio post-vendita
 Servicio postventa
 アフターサービス



积木补件
 Brick Replacement Service
 Ziegelstein-Ersatzdienst
 Service de remplacement de briques
 Servizio di sostituzione dei mattoncini
 Servicio de reemplazo de ladrillos
 ブロック交換サービス

OPEN

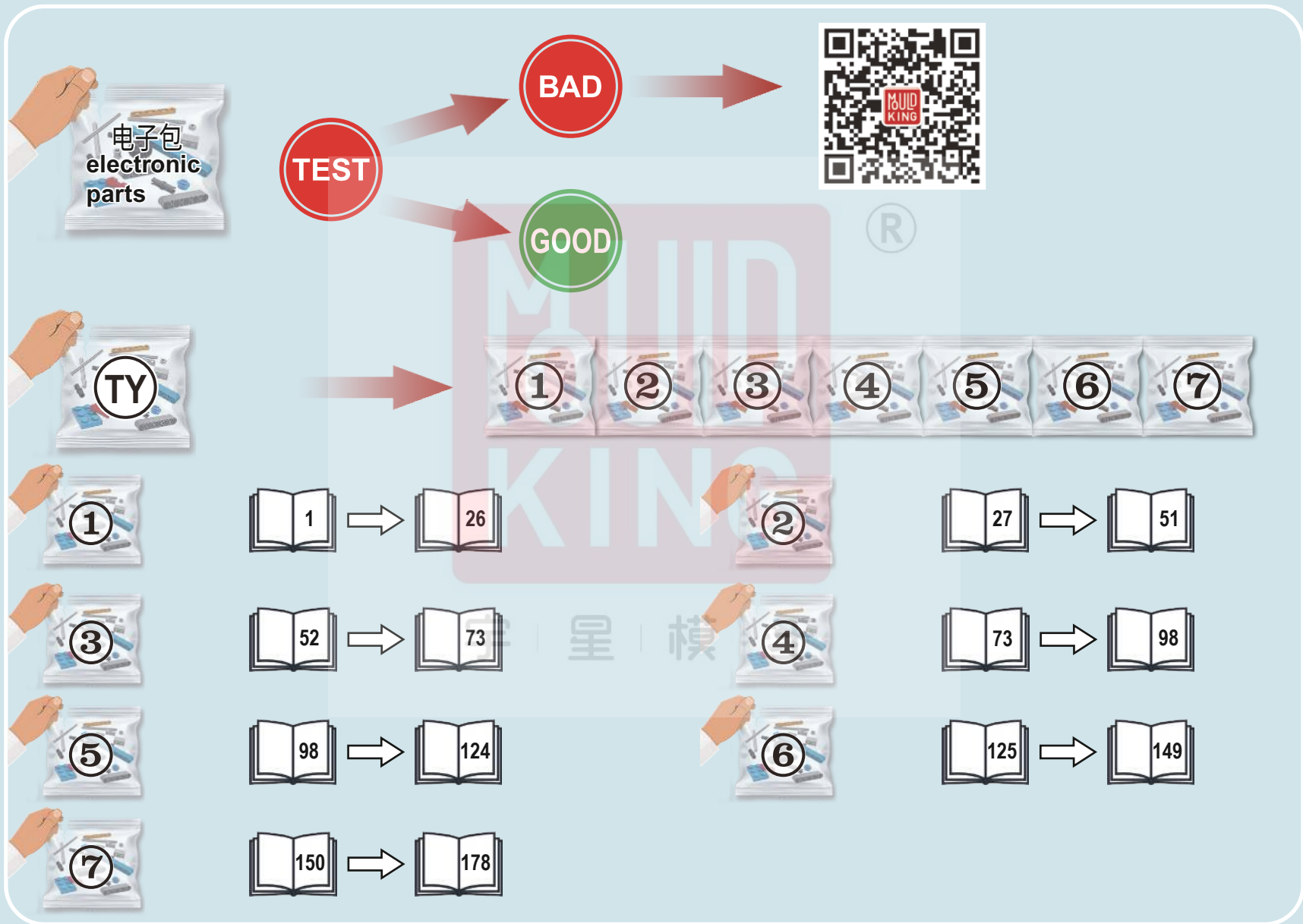

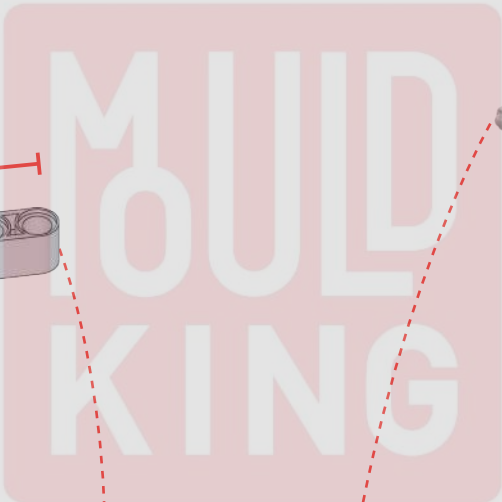

宇 | 星 | 模 | 王

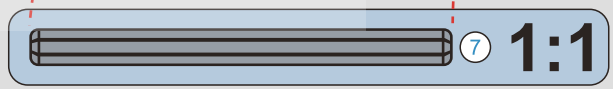
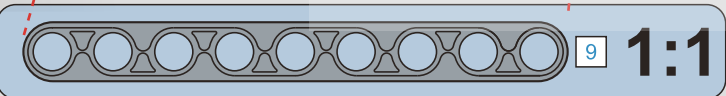
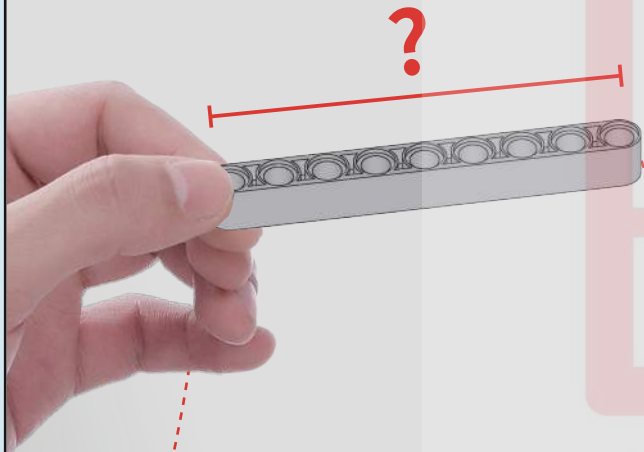

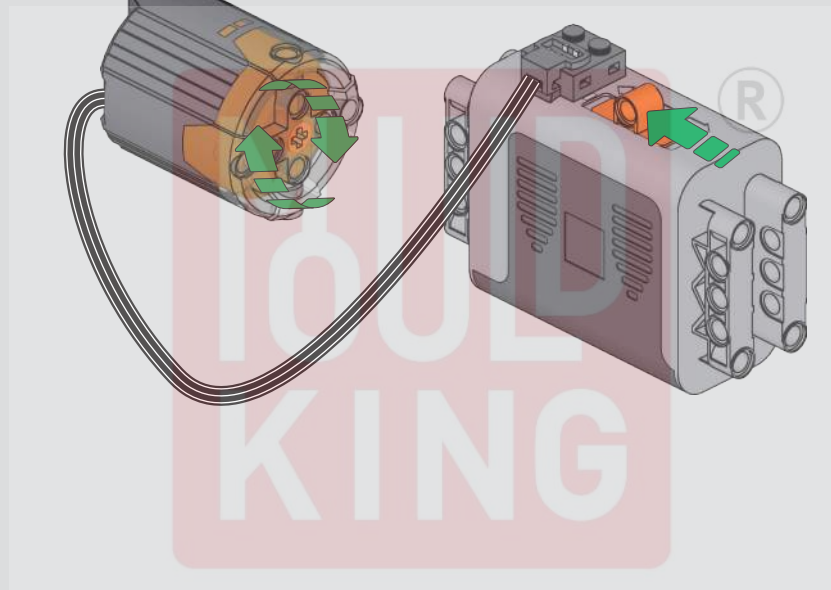

拼装前需测试所有电子件功能是否正常，此电池盒需自行装配电池

Test all electronic components for functionality before assembly; the battery box needs to be assembled by yourself.

Testen Sie alle elektronischen Komponenten auf ihre Funktionalität, bevor Sie sie zusammenbauen; das Batteriefach muss selbst zusammengebaut werden.

Testez toutes les composantes électroniques pour leur fonctionnalité avant l'assemblage; le boîtier de batterie doit être assemblé par vous-même.

Testa tutte le componenti elettroniche per la loro funzionalità prima dell'assemblaggio; la scatola delle batterie deve essere assemblata da te.

Pruebe todas las componentes electrónicas para su funcionalidad antes del montaje; la caja de baterías necesita ser ensamblada por usted mismo.

組み立て前にすべての電子部品の機能をテストし、このバッテリーボックスは自分で組み立てる必要があります。

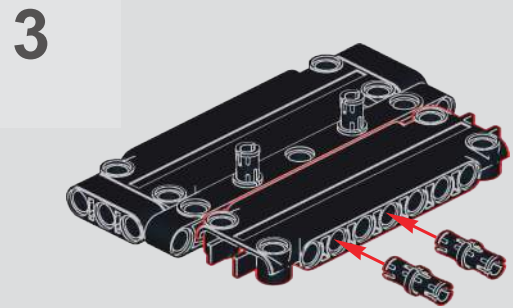
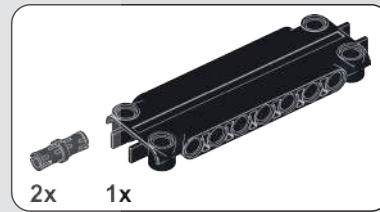
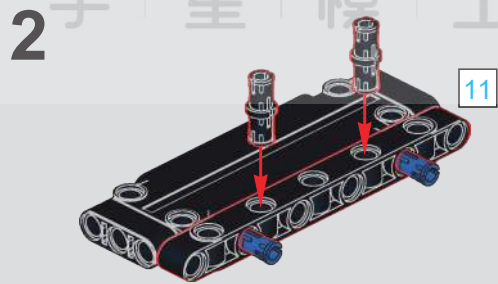
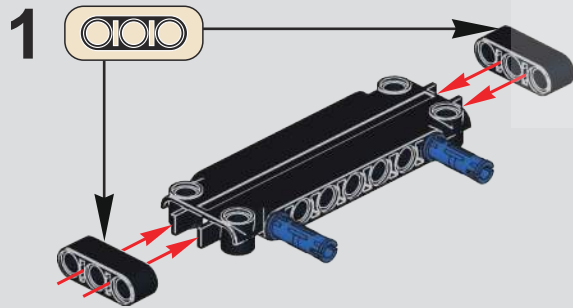
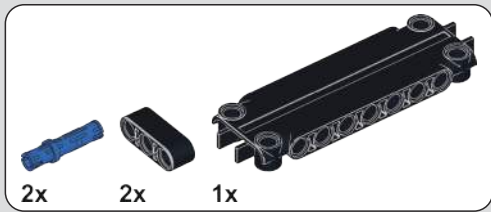
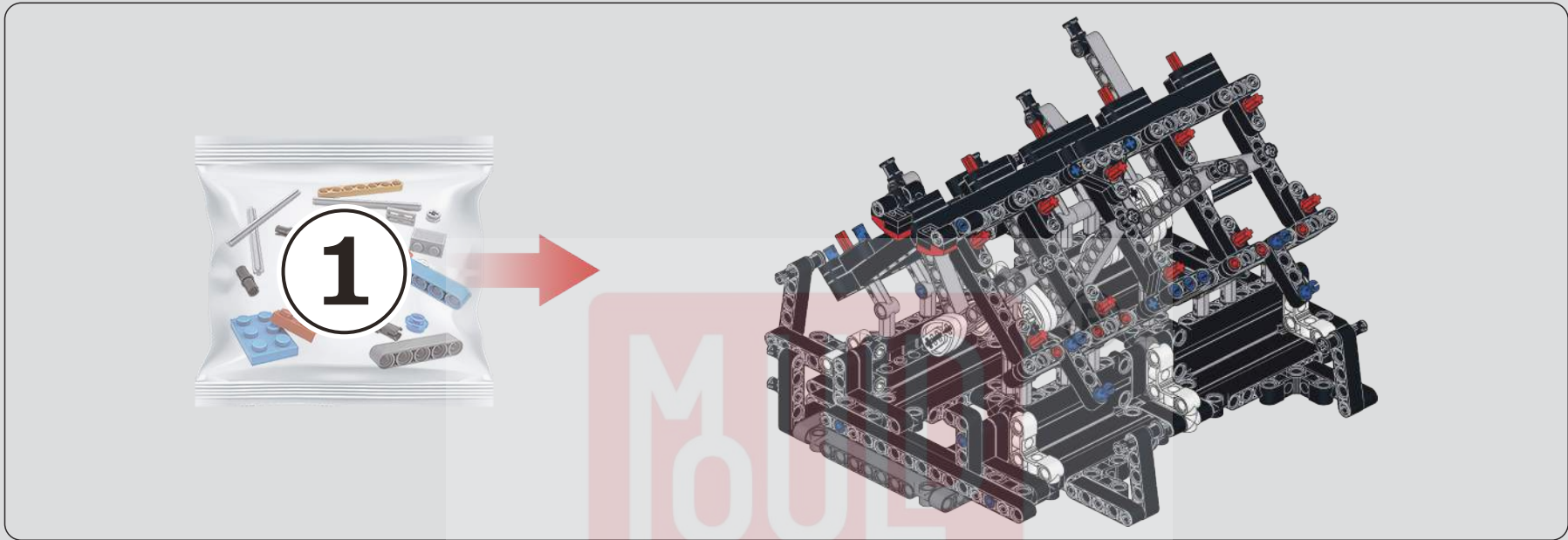

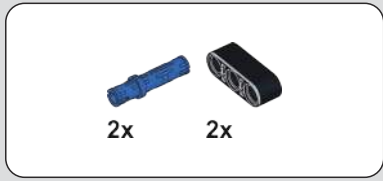

4

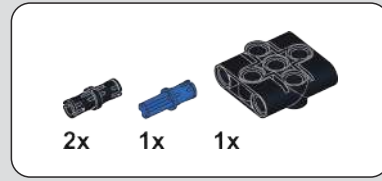
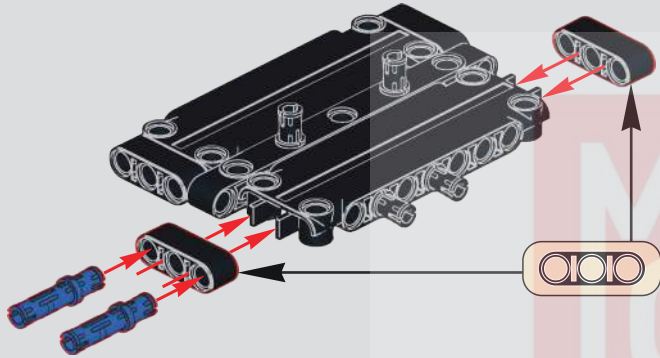

5

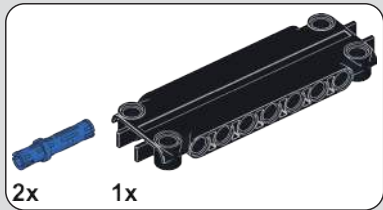
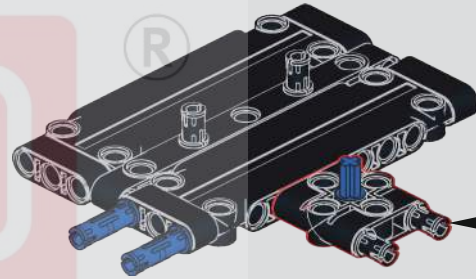

6

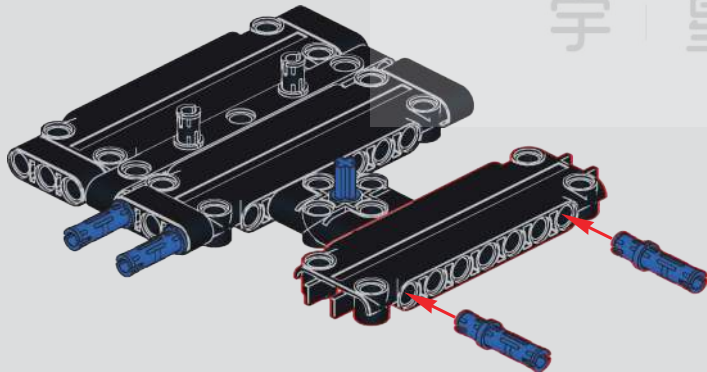

宇星7模王

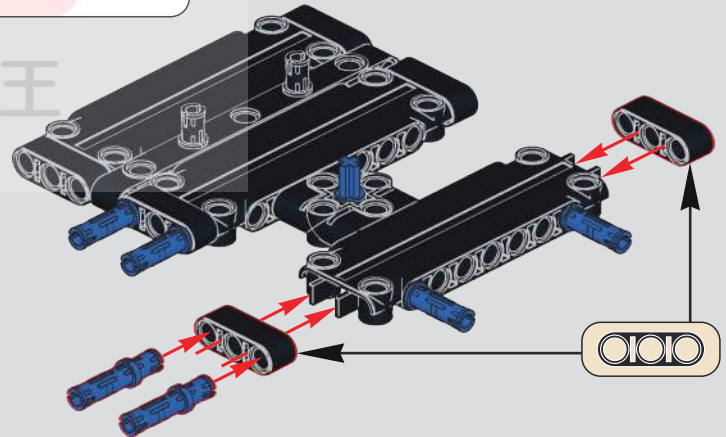

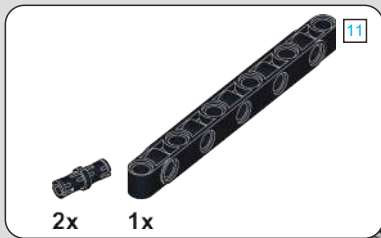

8

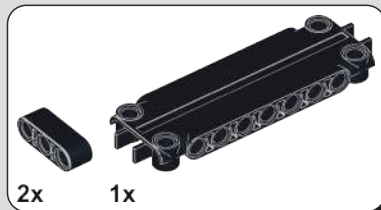
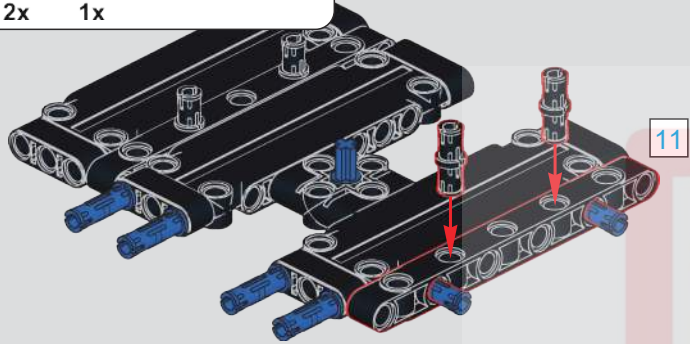

9

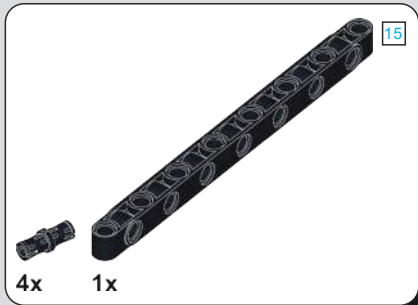
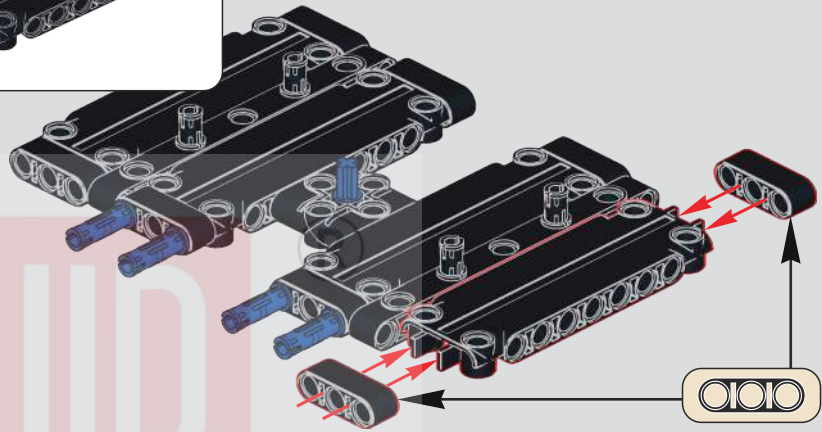

10

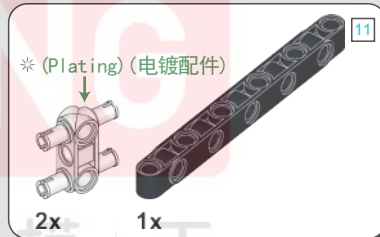
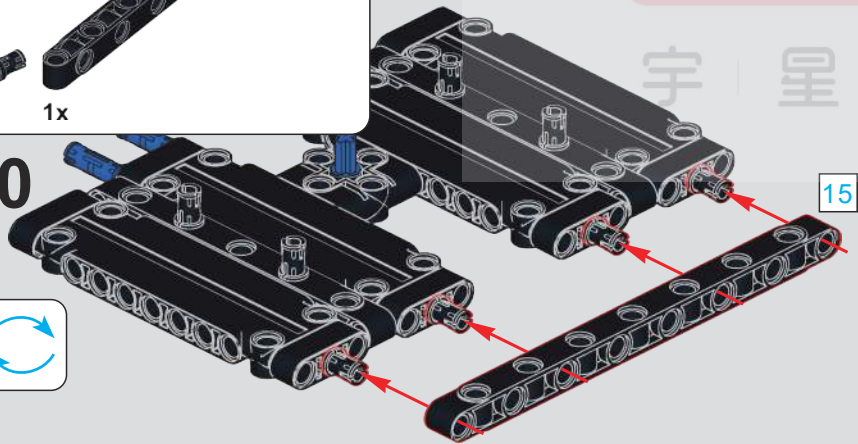

11

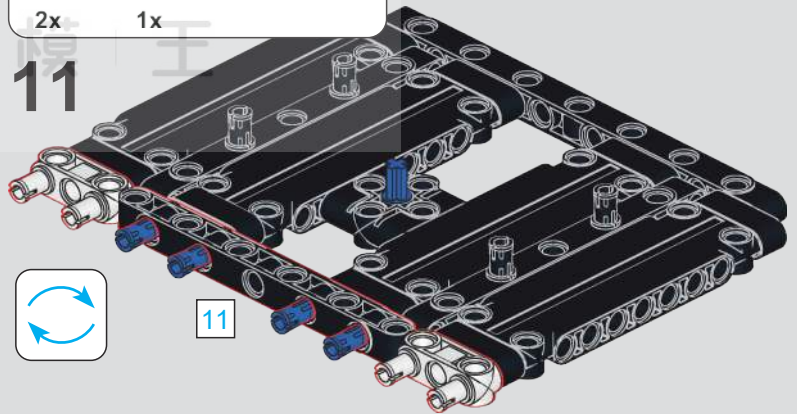



12

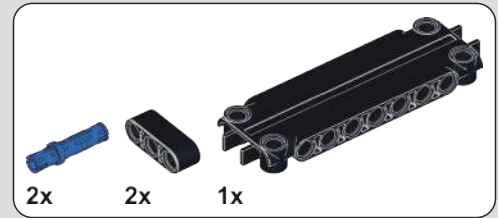
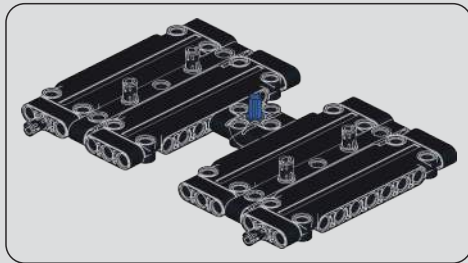
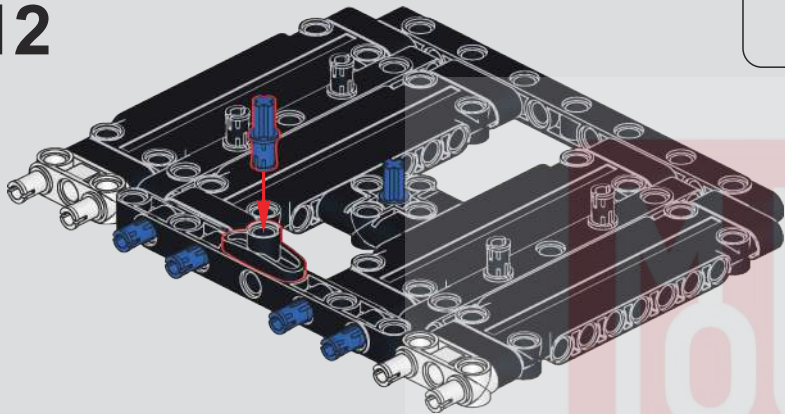

13

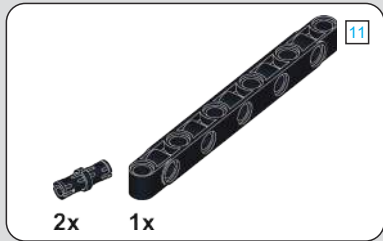
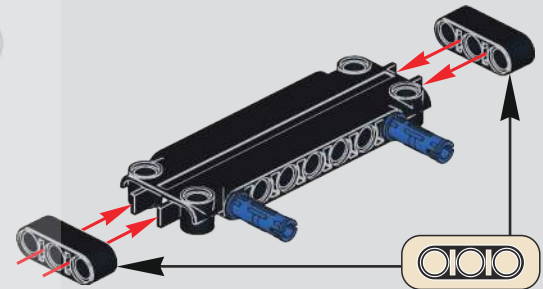

14

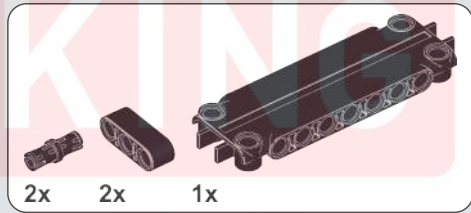
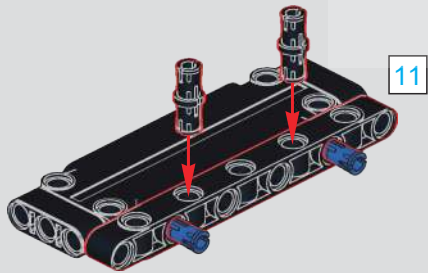

15

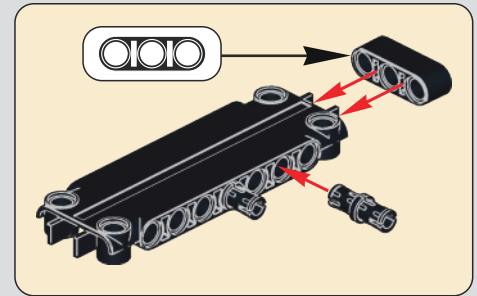

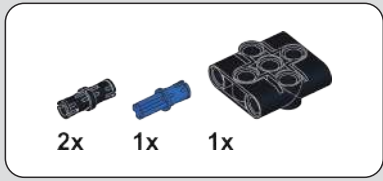

16

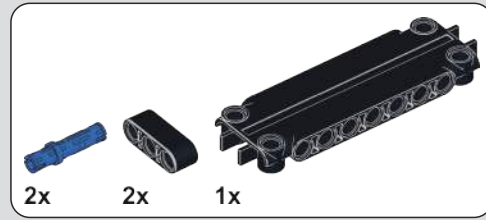
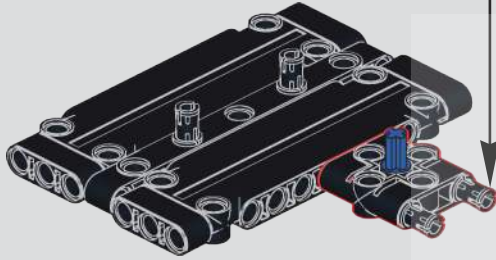
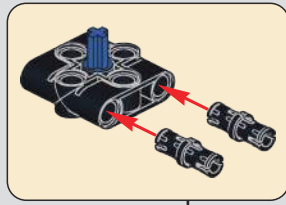

17

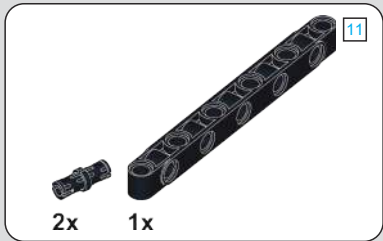
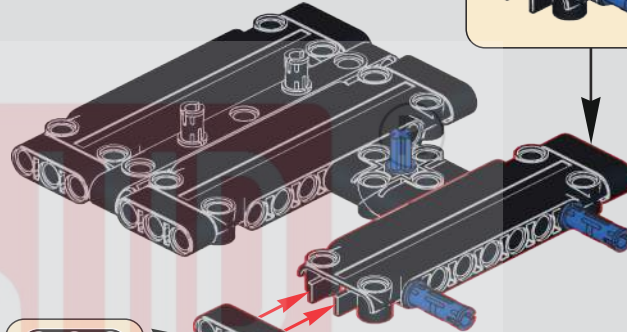
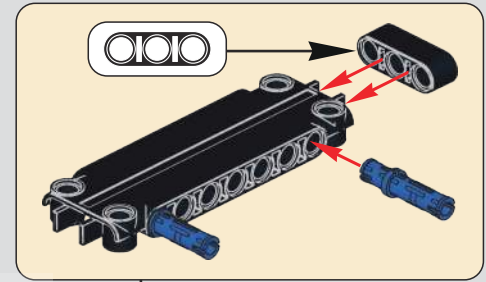

18

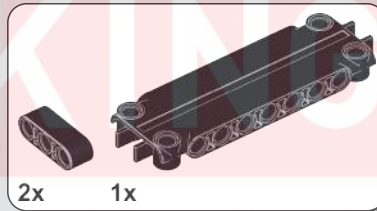

19

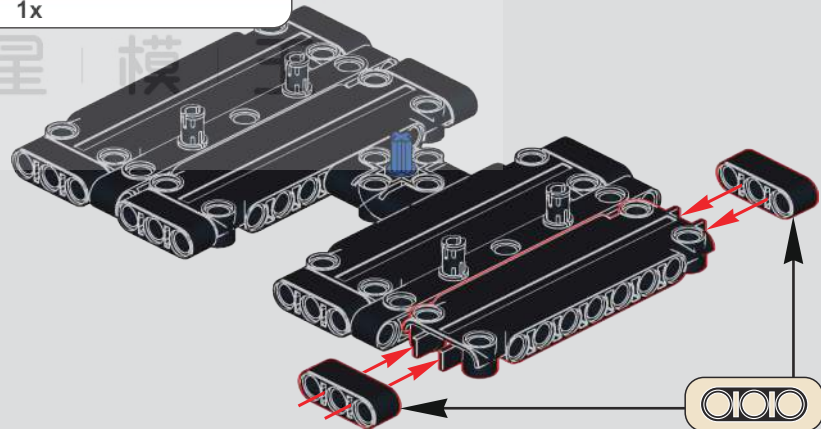
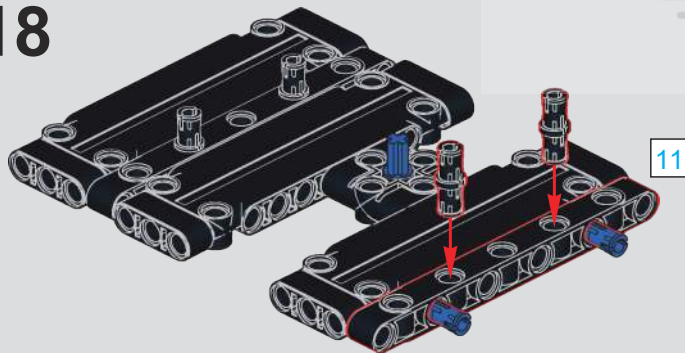

21



20

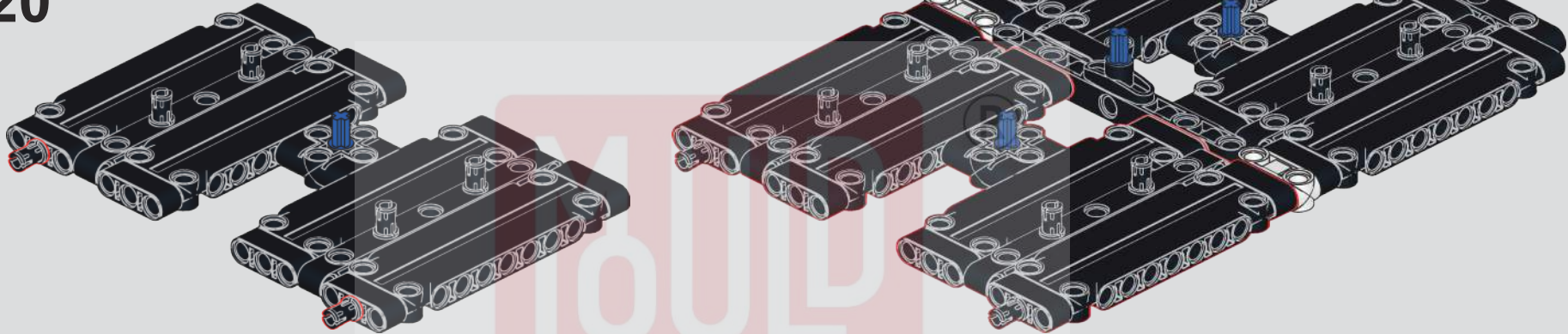

22

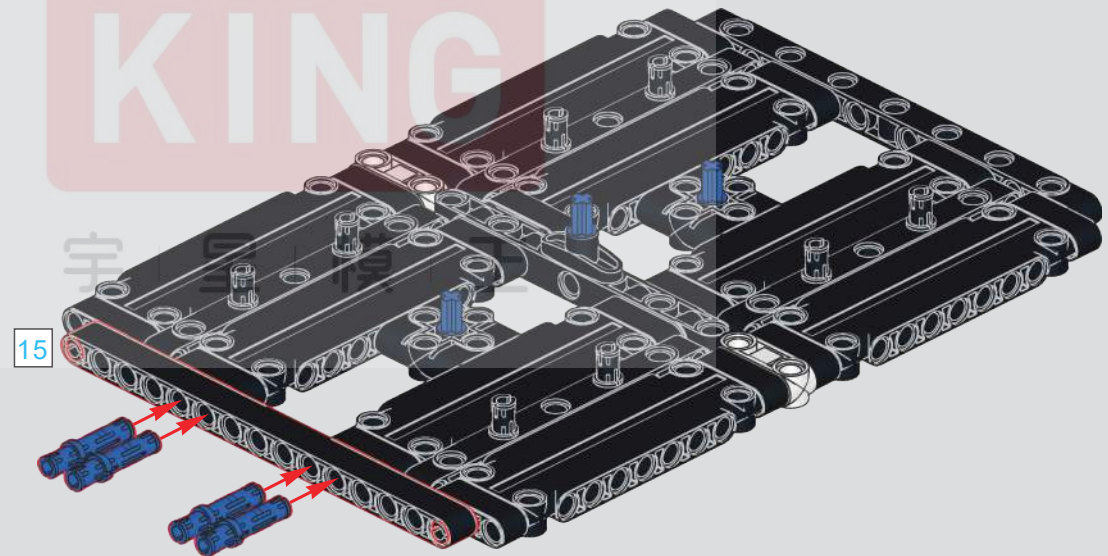

23

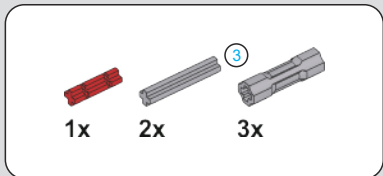
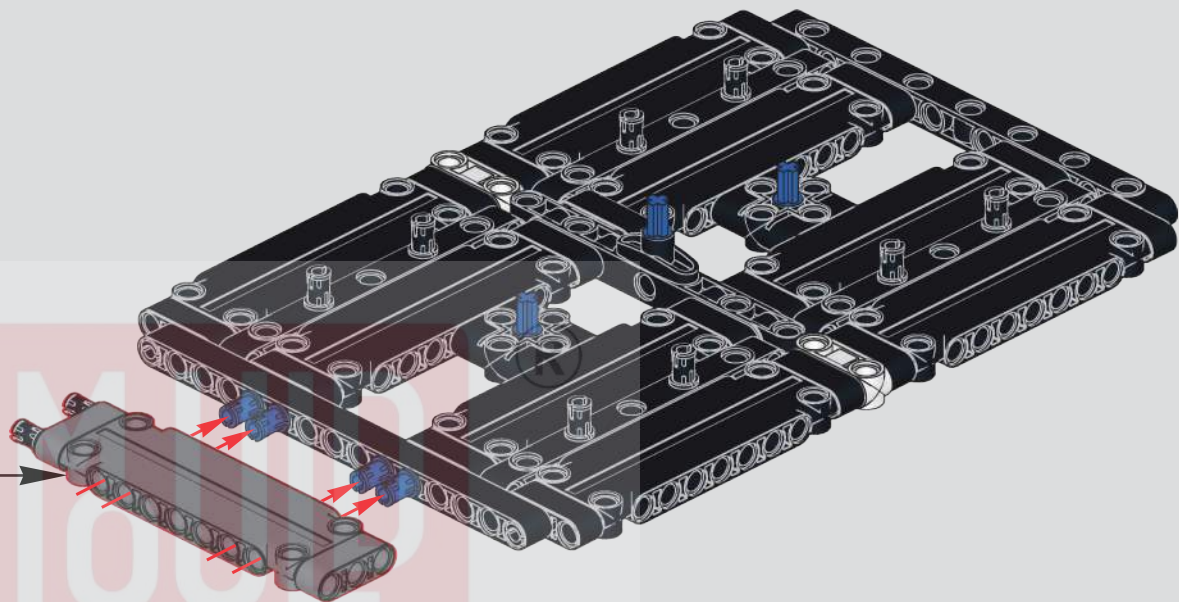
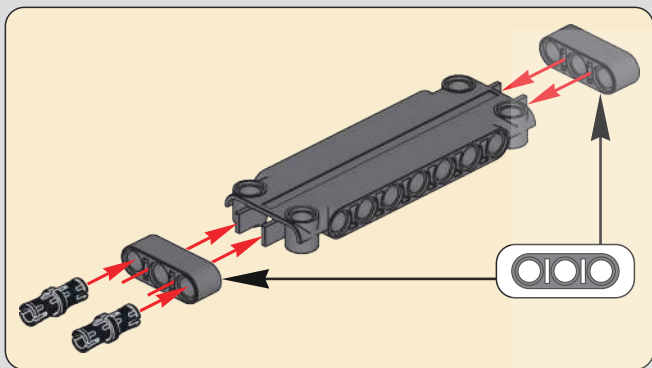
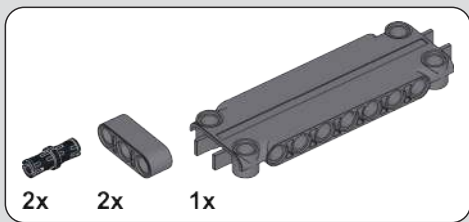

24

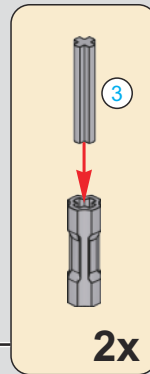
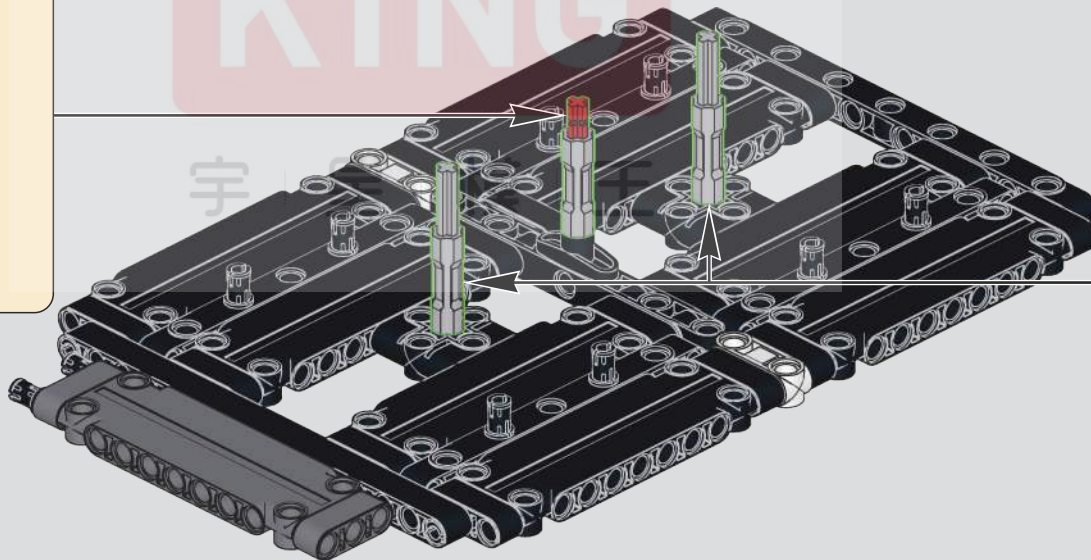
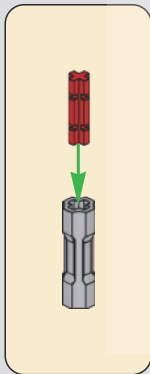

* (Plating) (电镀配件)



8x

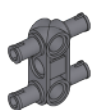

2x

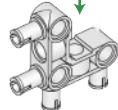

6x



4x

25

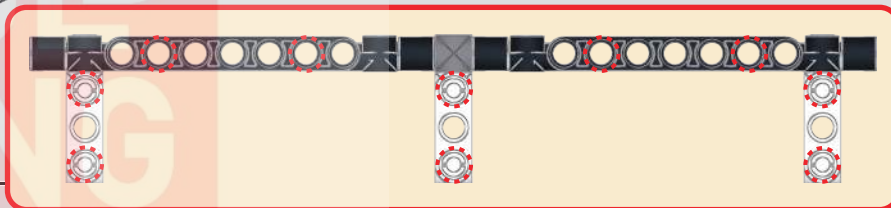
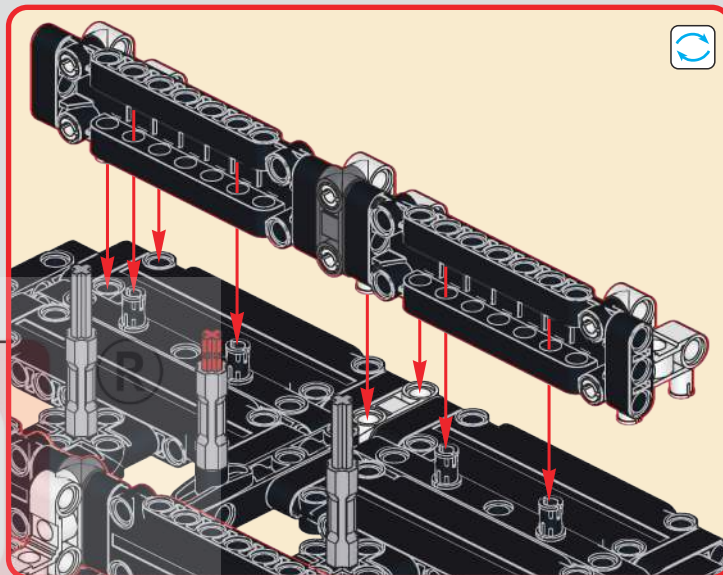
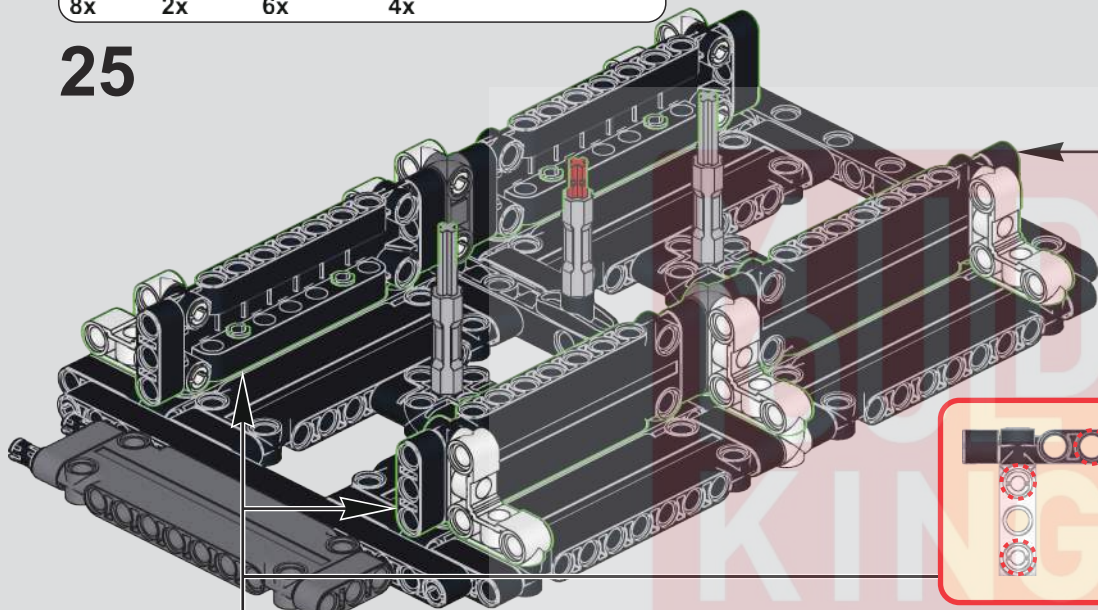

1

2

3

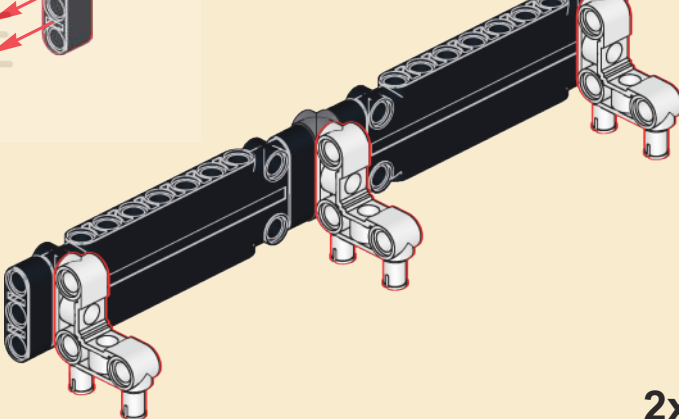
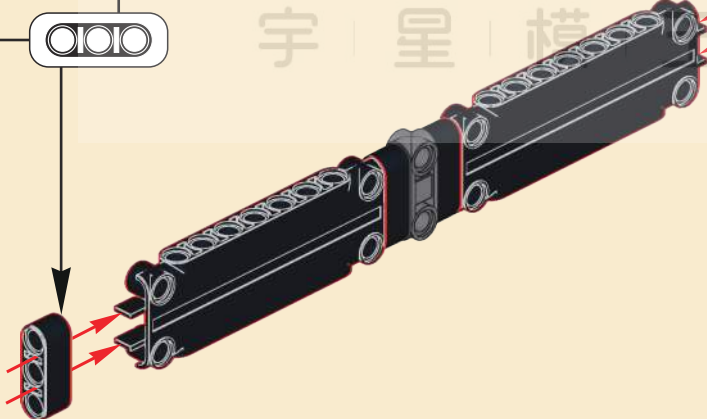
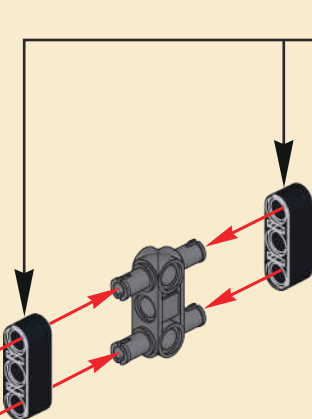

2x

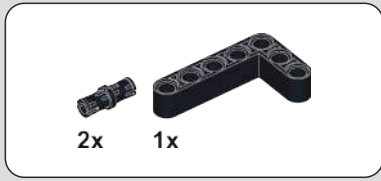

26

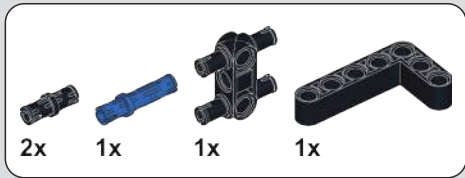
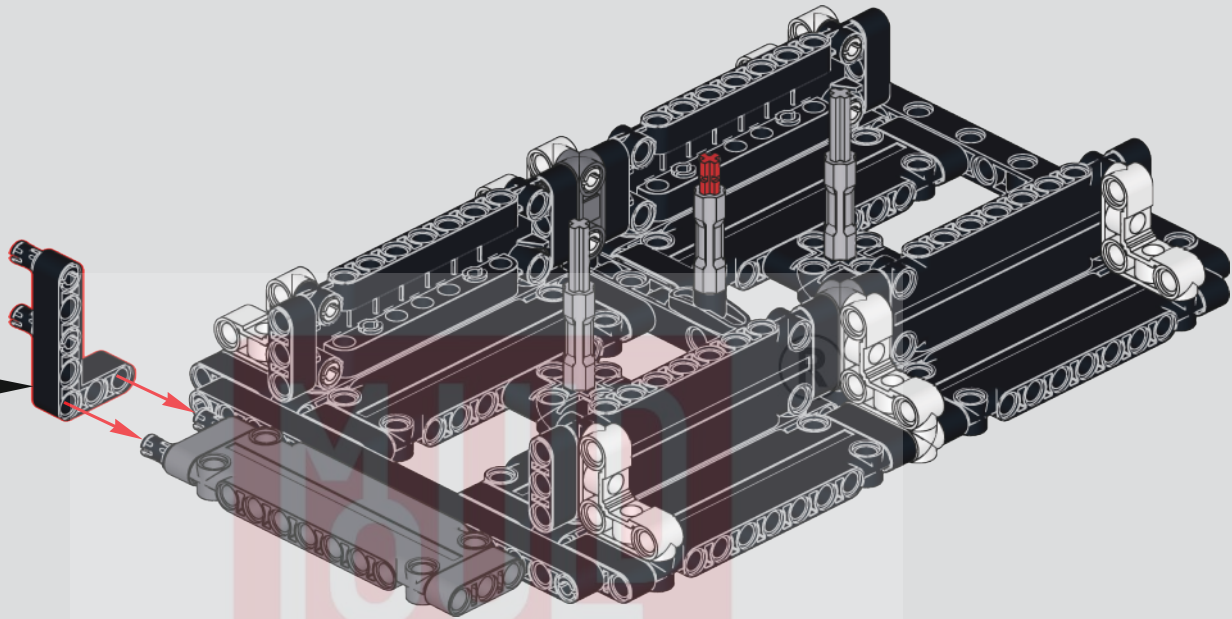
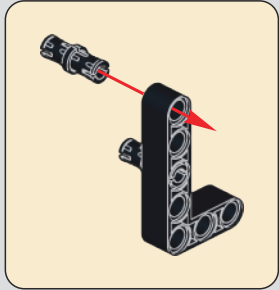

27

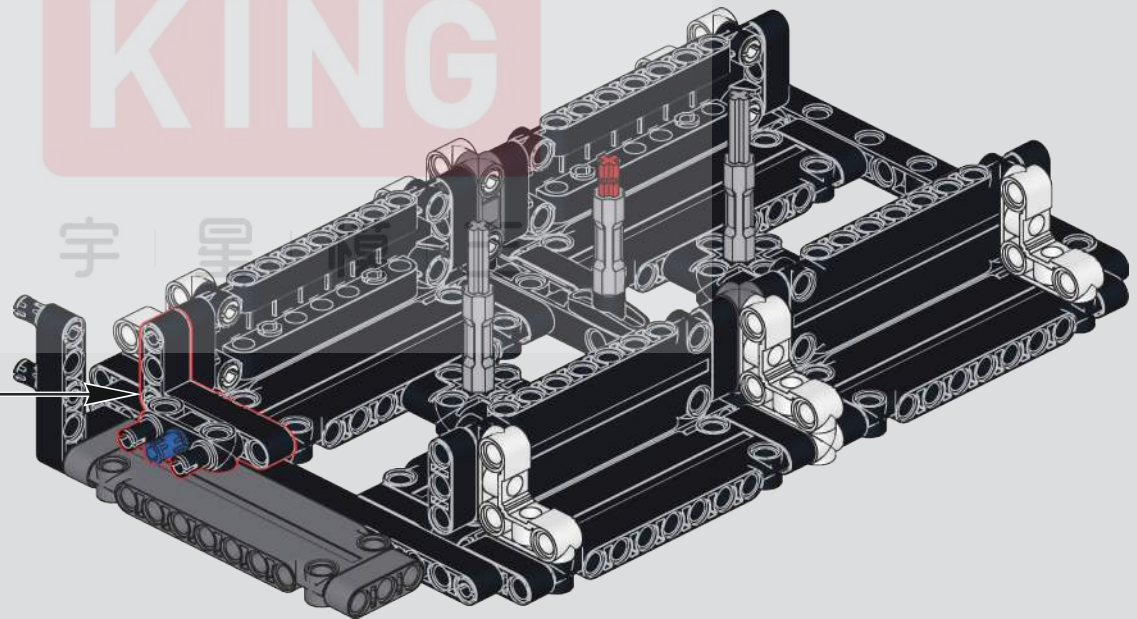
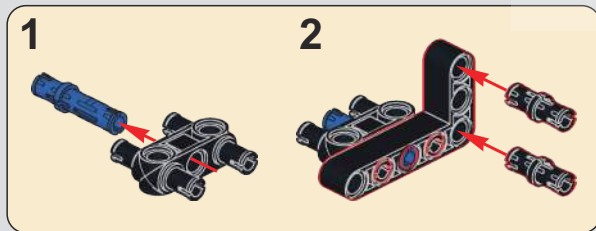

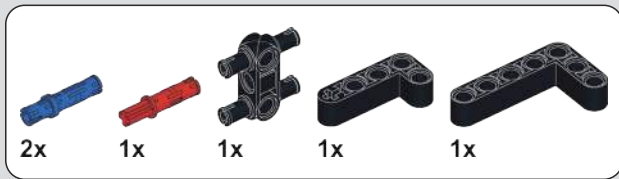

28

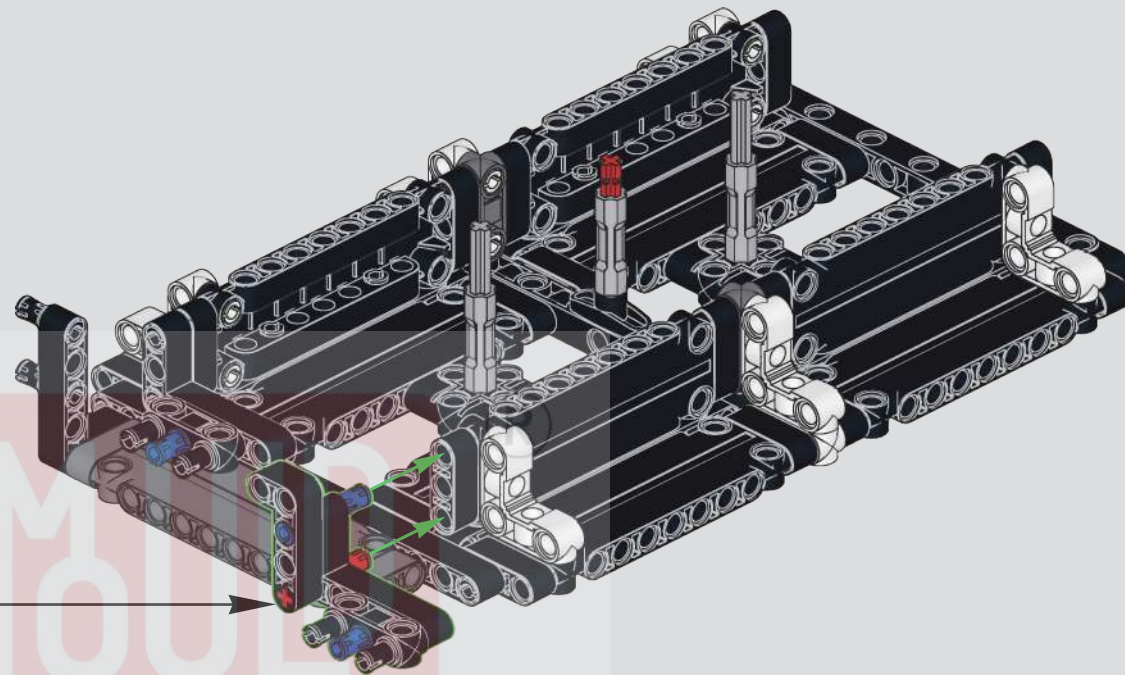
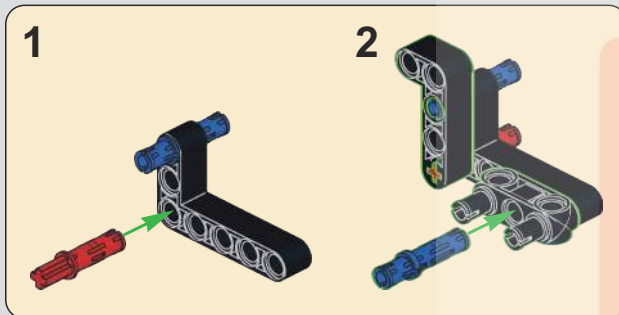

29

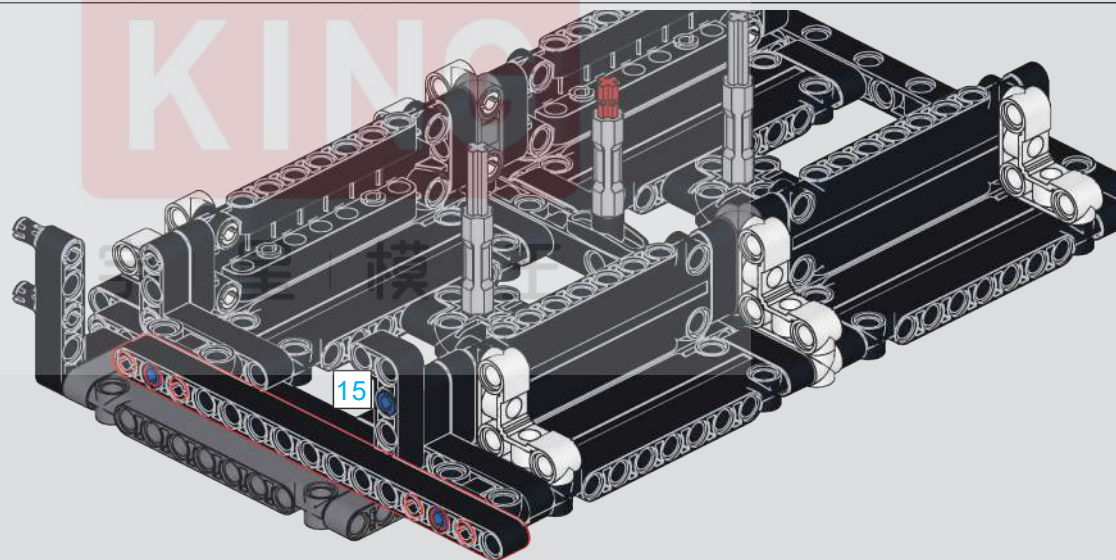

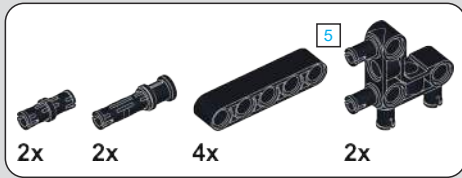

30

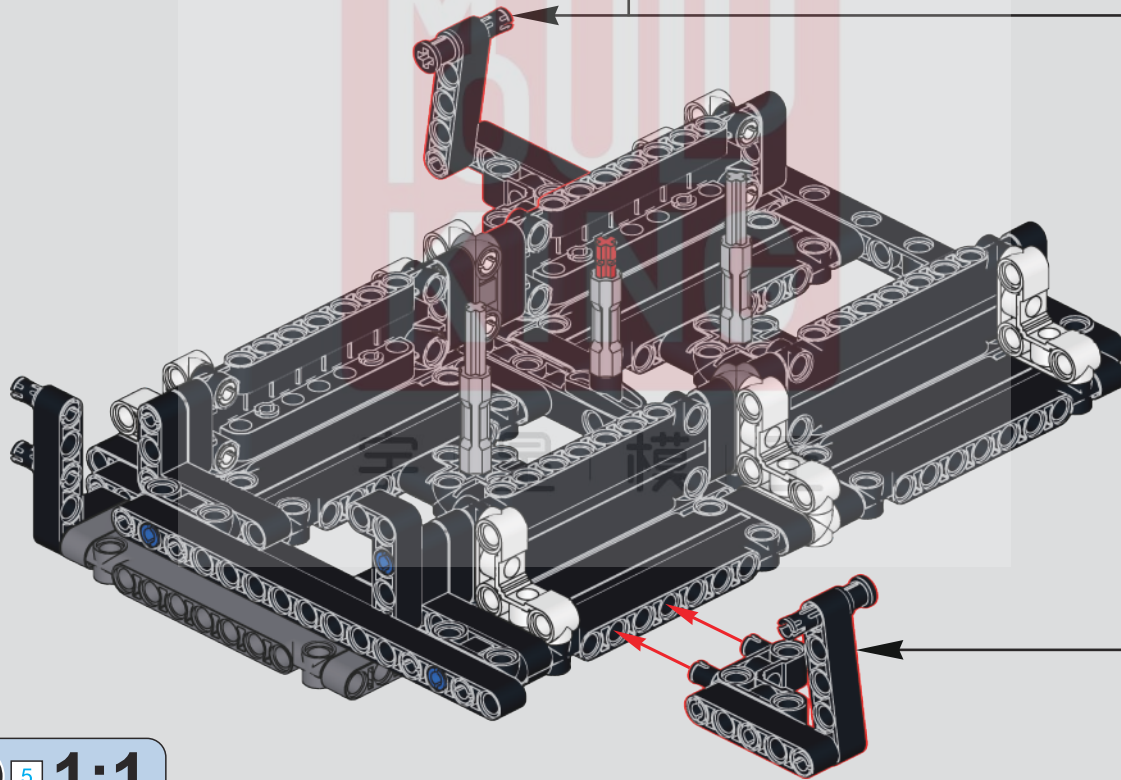
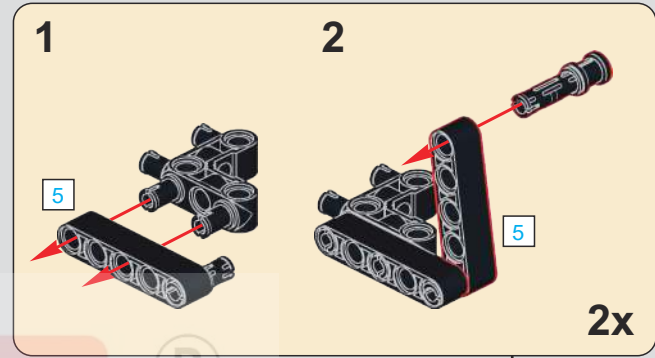
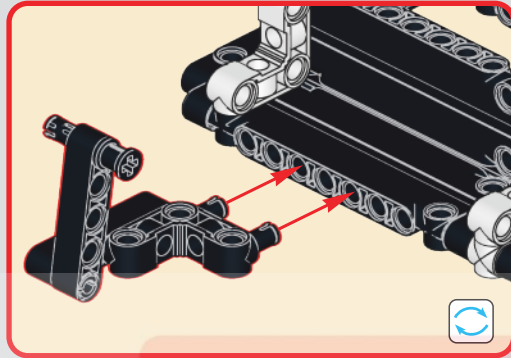

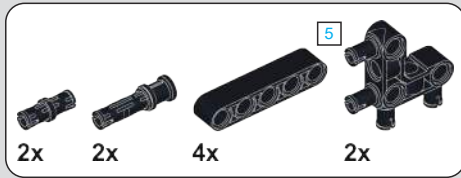

31

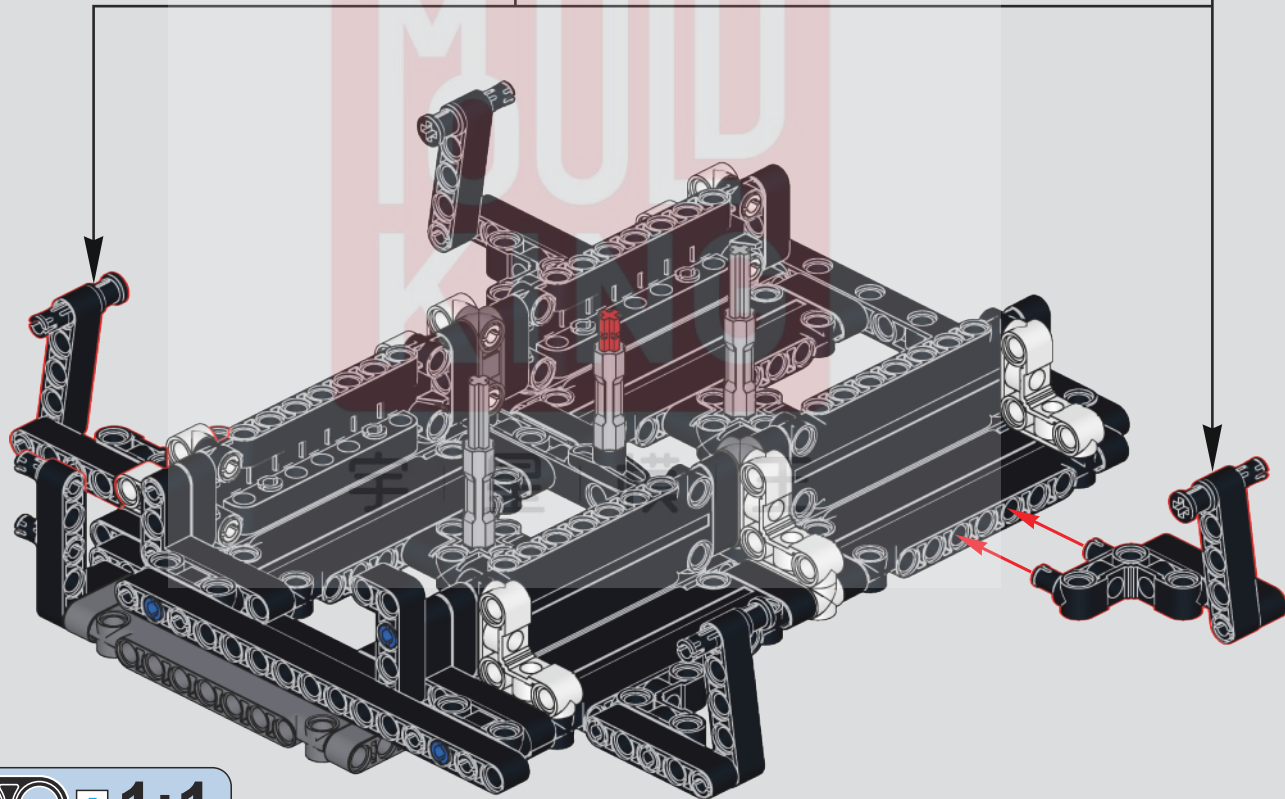
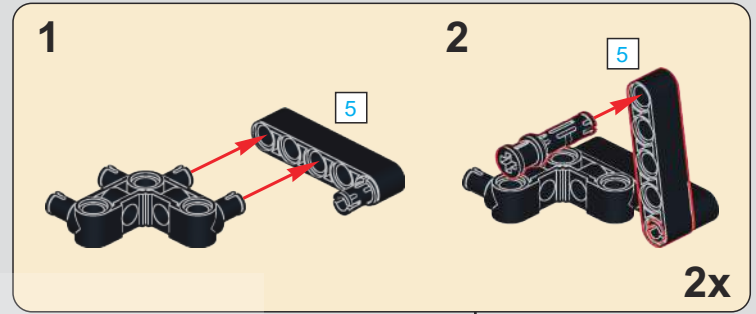
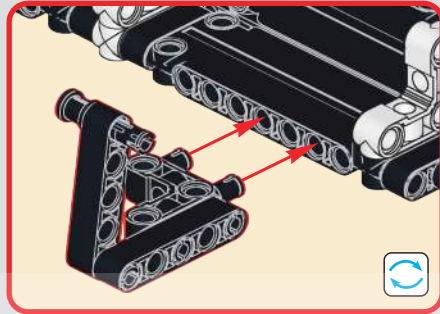

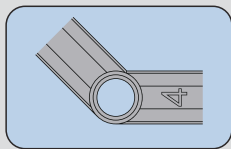
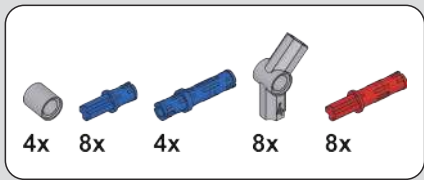

32

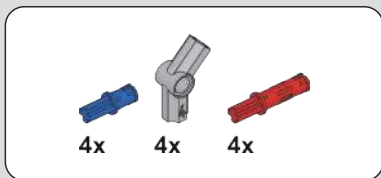
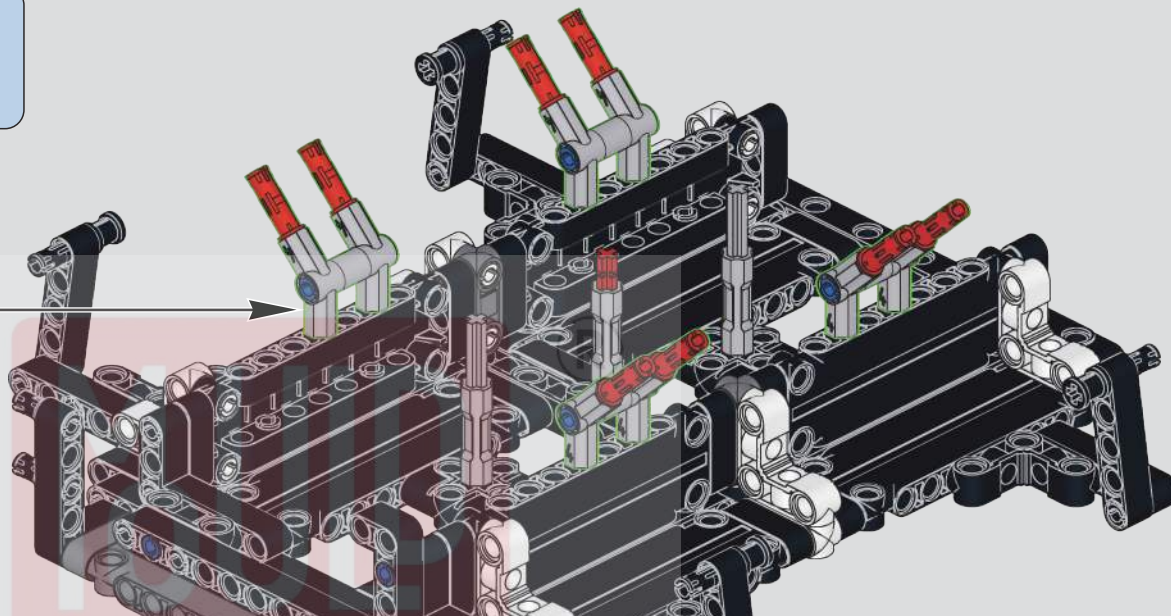
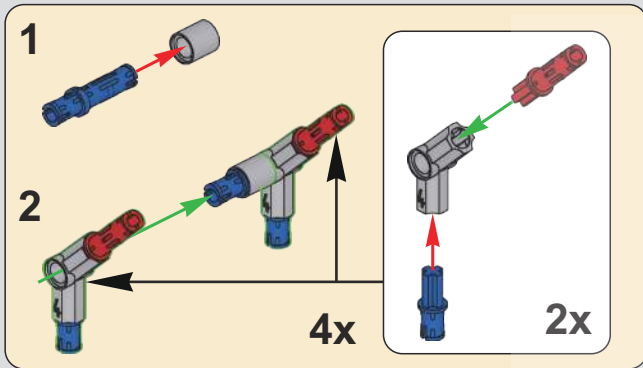

33

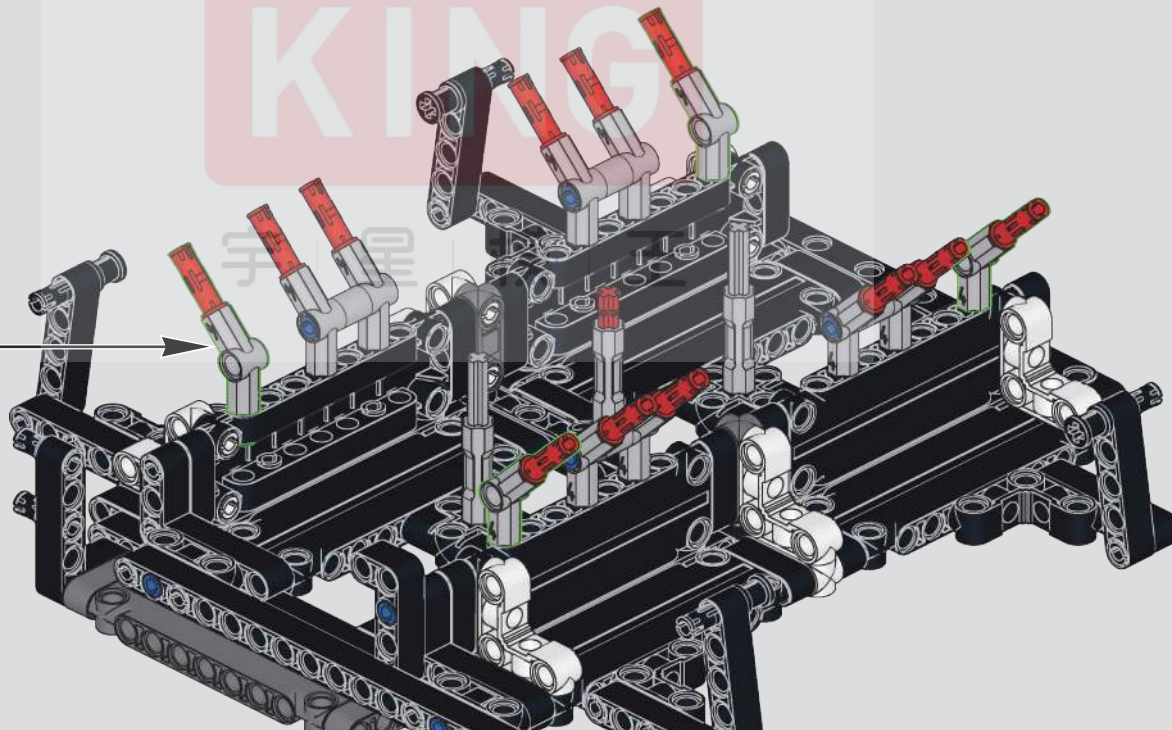
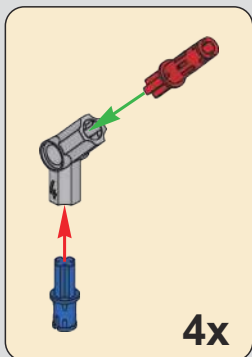

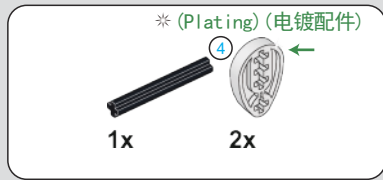
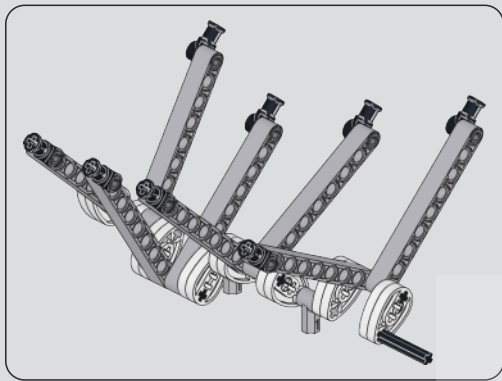

34

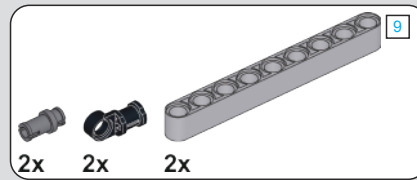

35

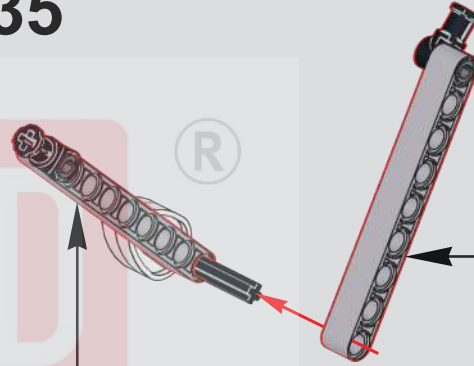
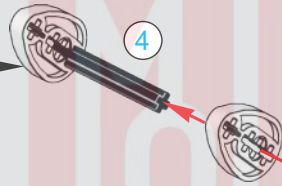
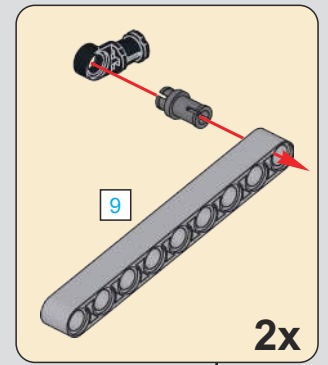

36

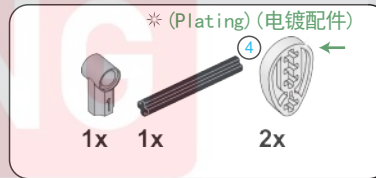
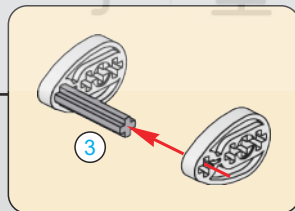
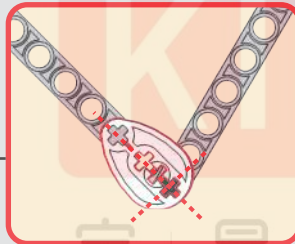

37

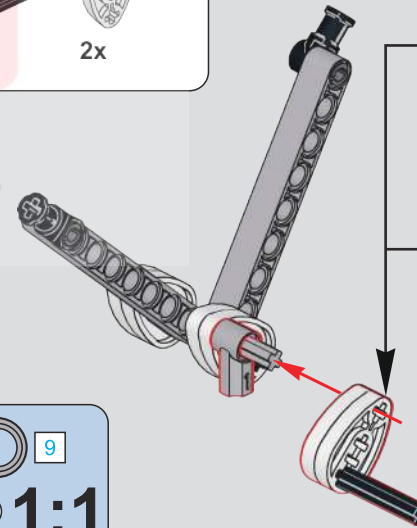
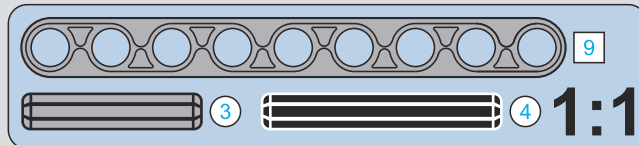
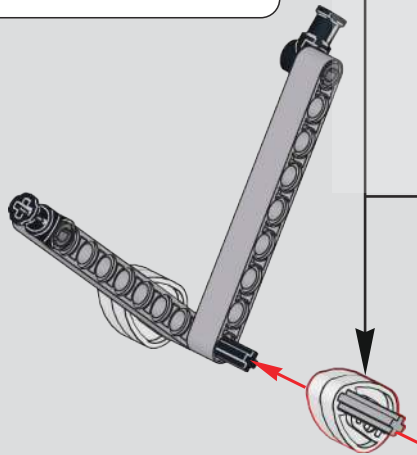
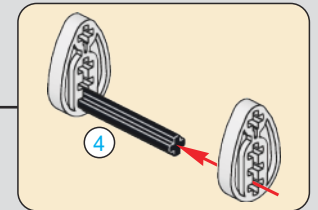
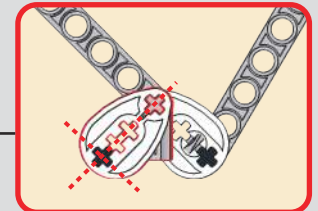

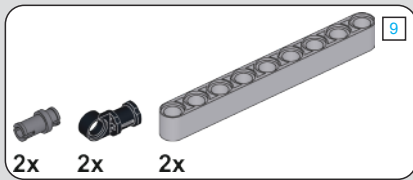

38

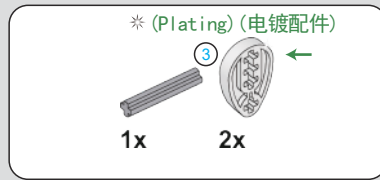
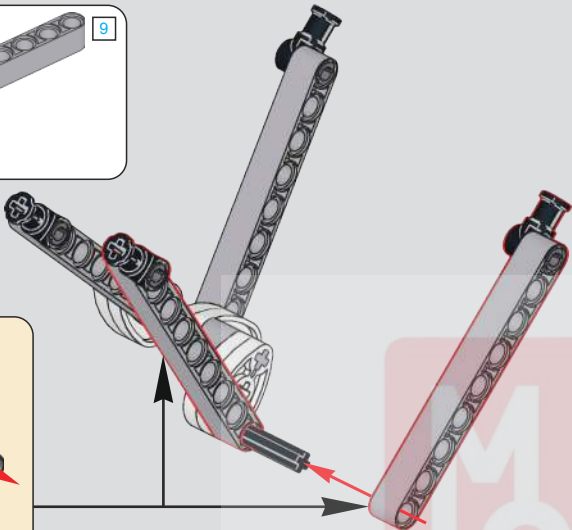
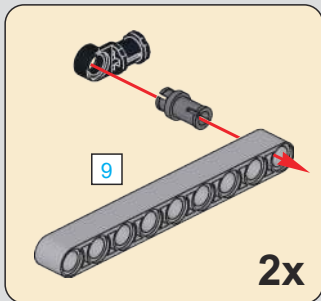

39

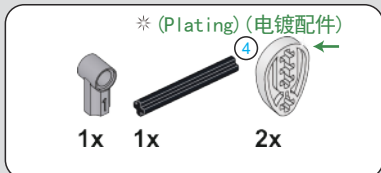
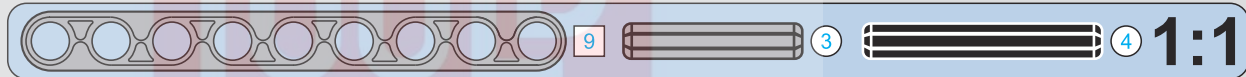
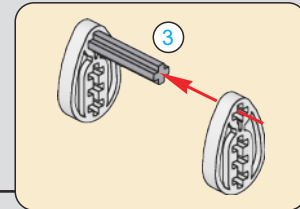
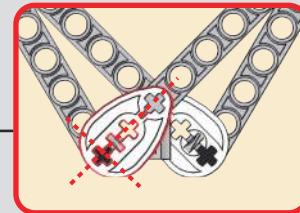
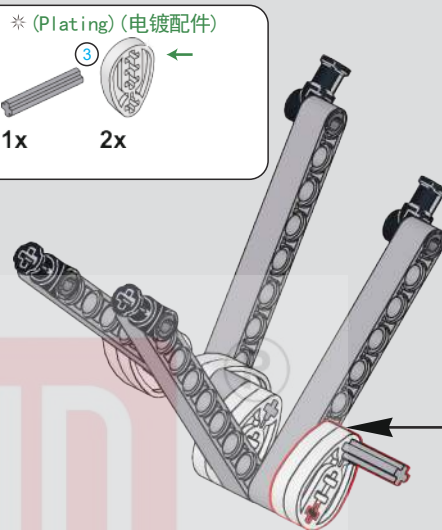

40

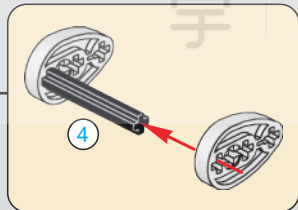
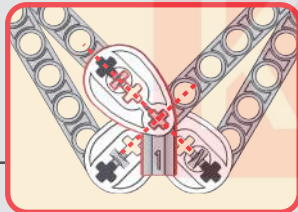
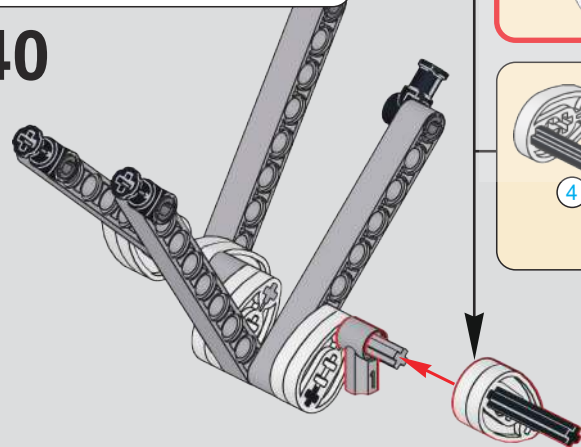

41

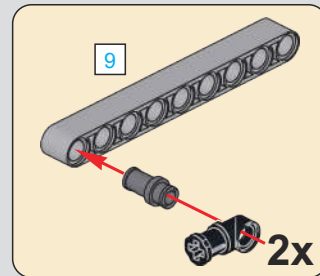
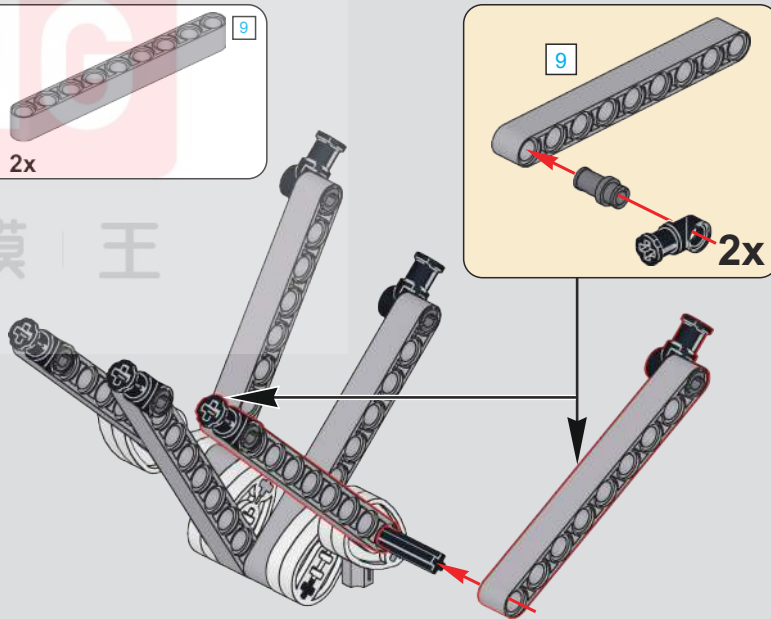

* (Plating) (电镀配件)

1x 2x

42

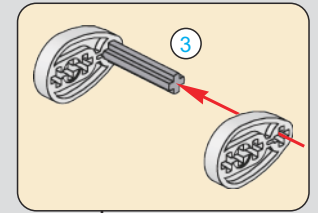
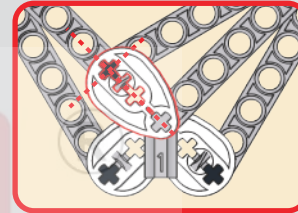
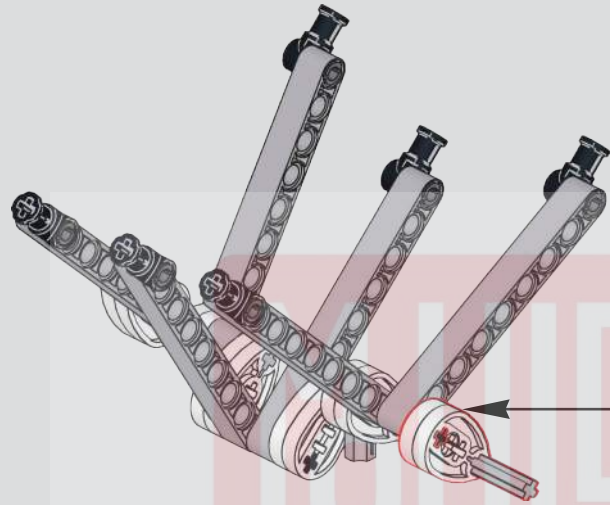

3 4 1:1

* (Plating) (电镀配件)

1x 1x 2x

43

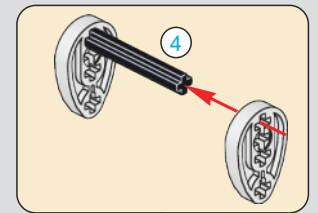
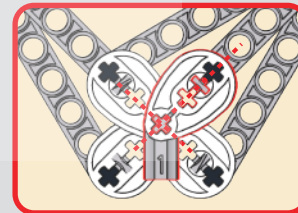
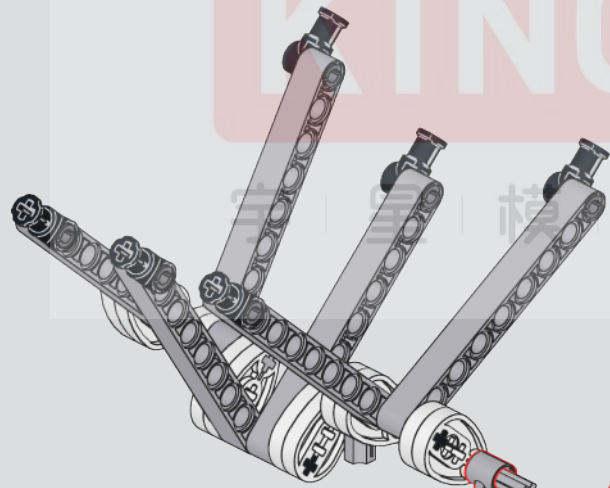

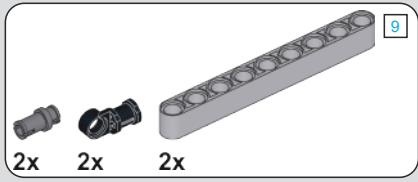

44

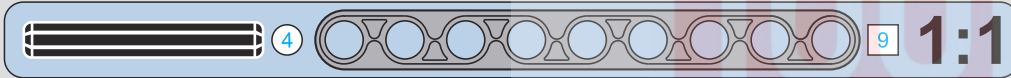
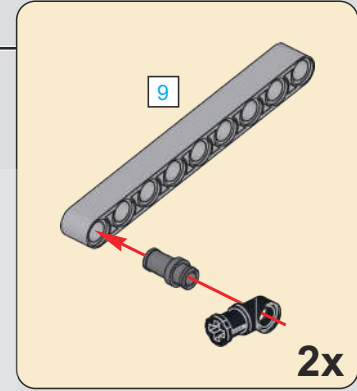
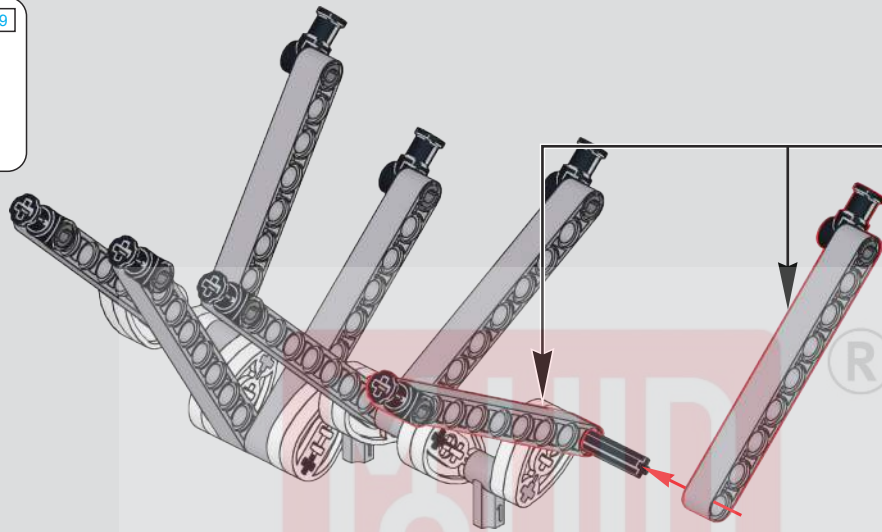

45

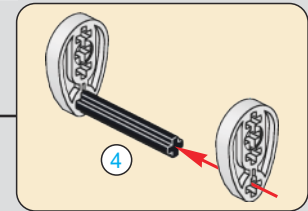
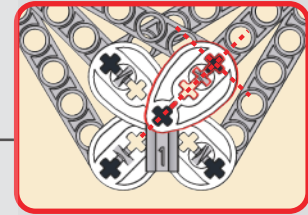
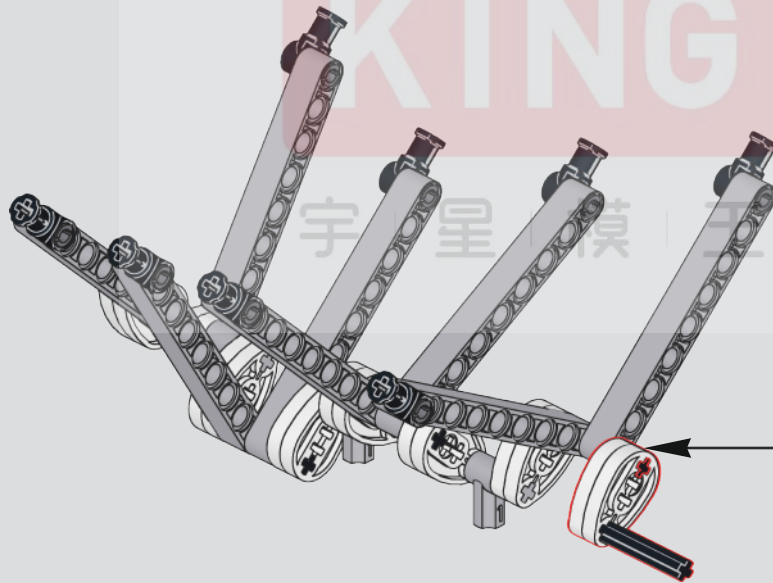

46

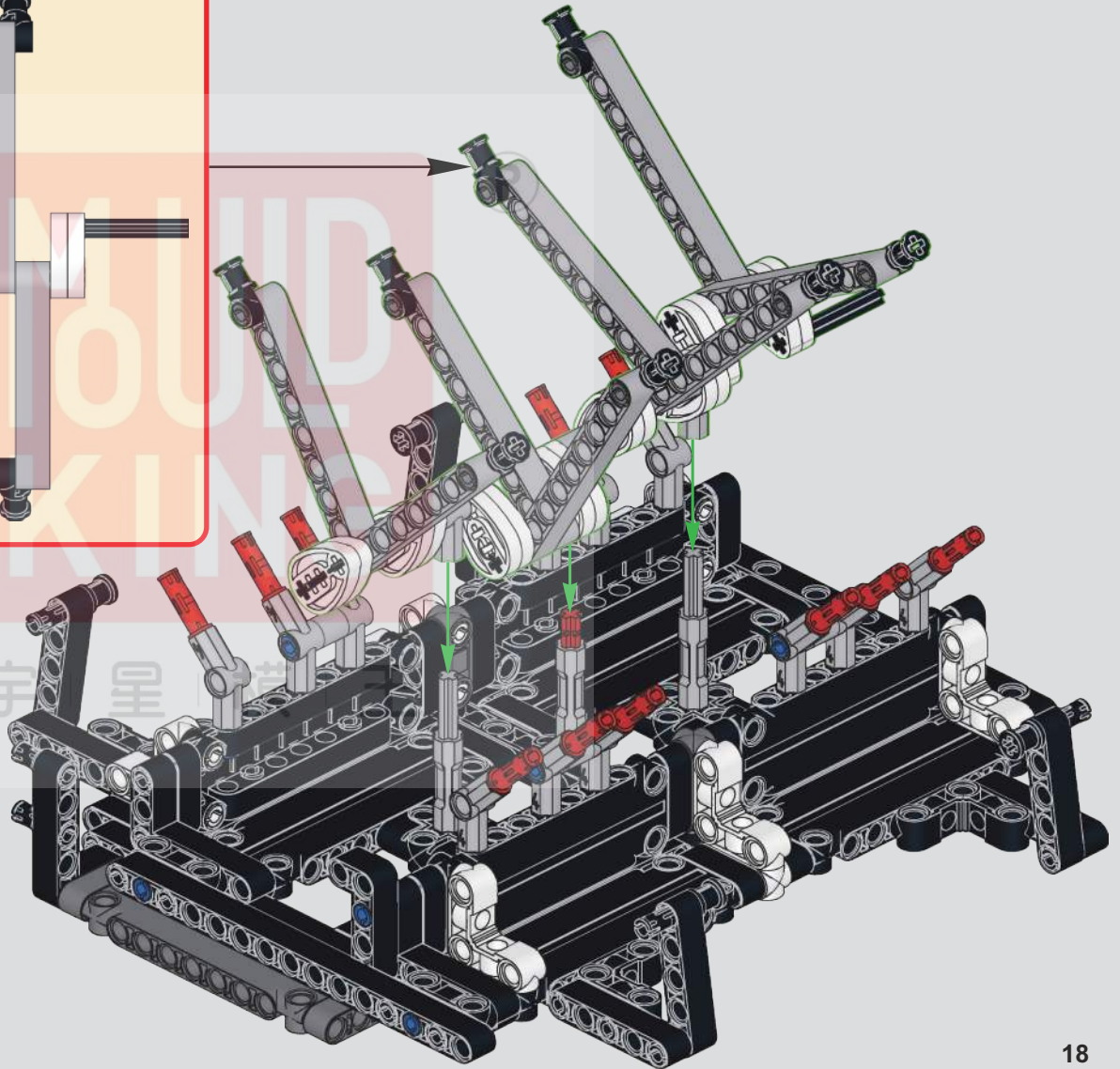
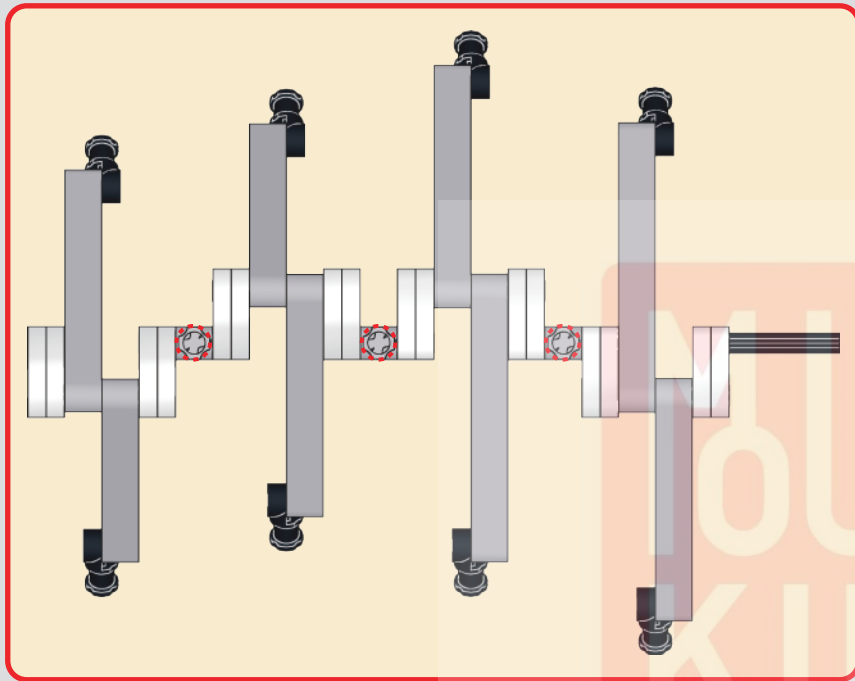

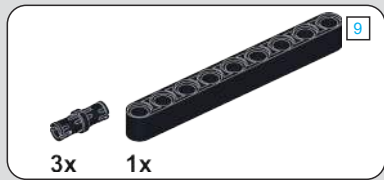
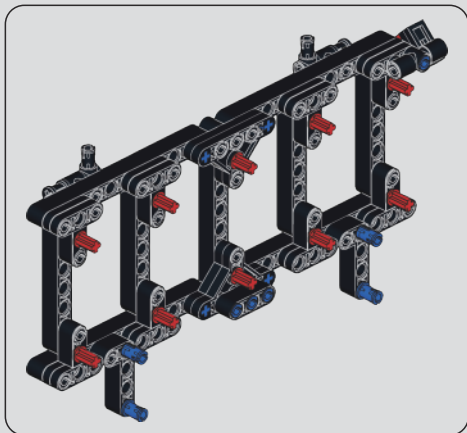

47

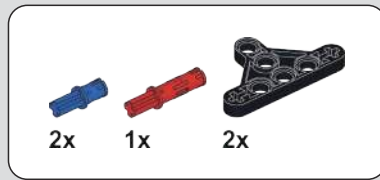
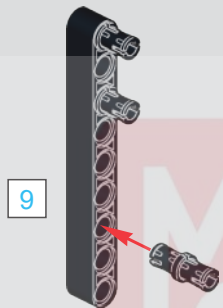

48

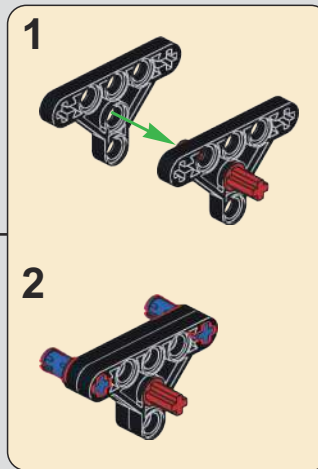
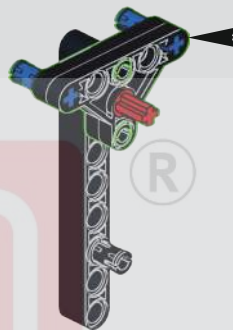

49

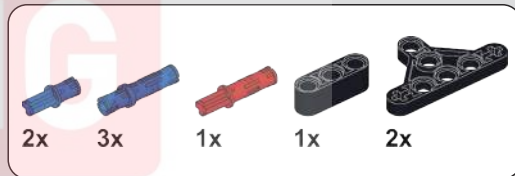
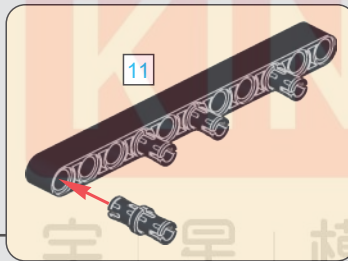
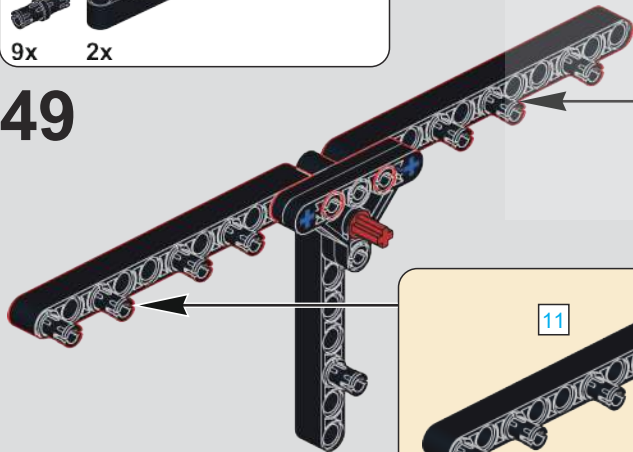

50

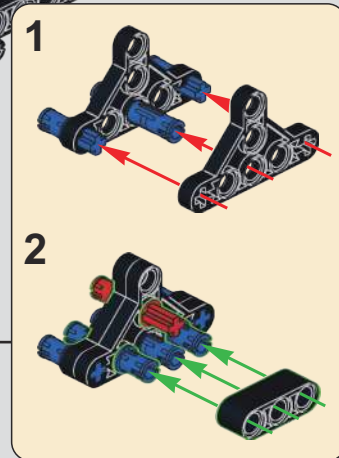
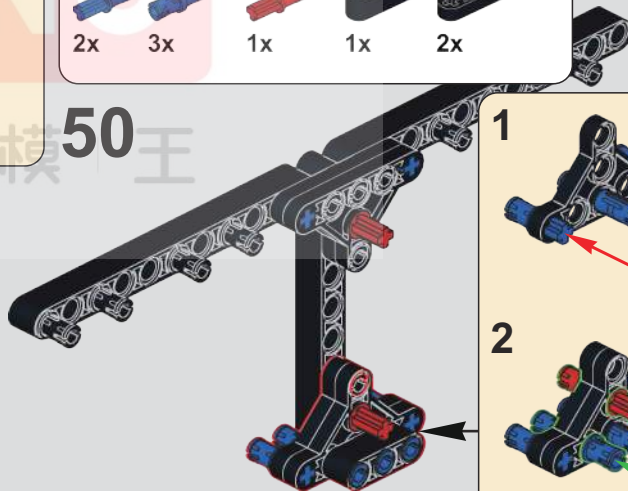

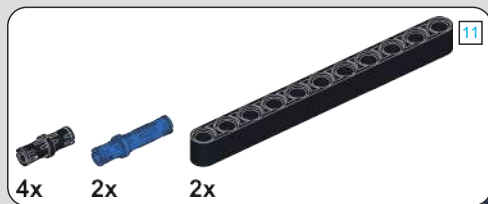

51

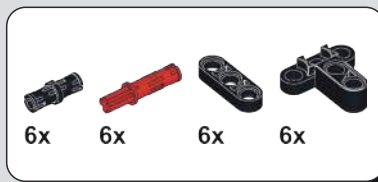
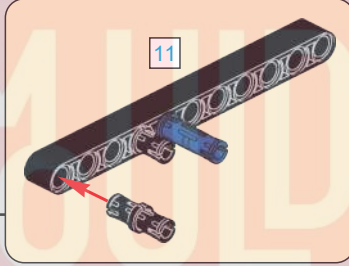
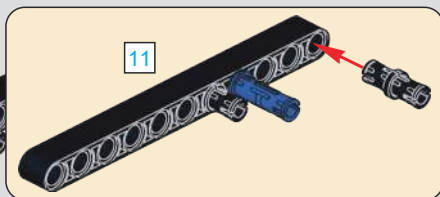
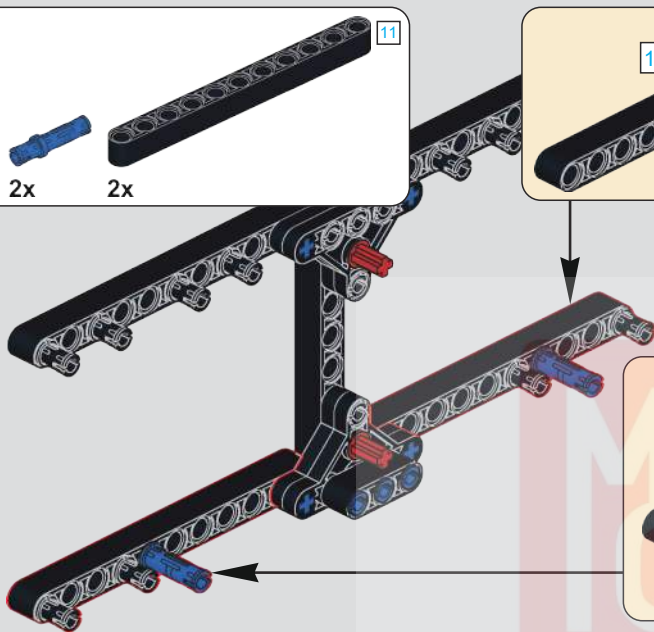

52

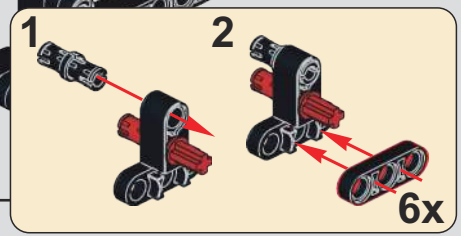
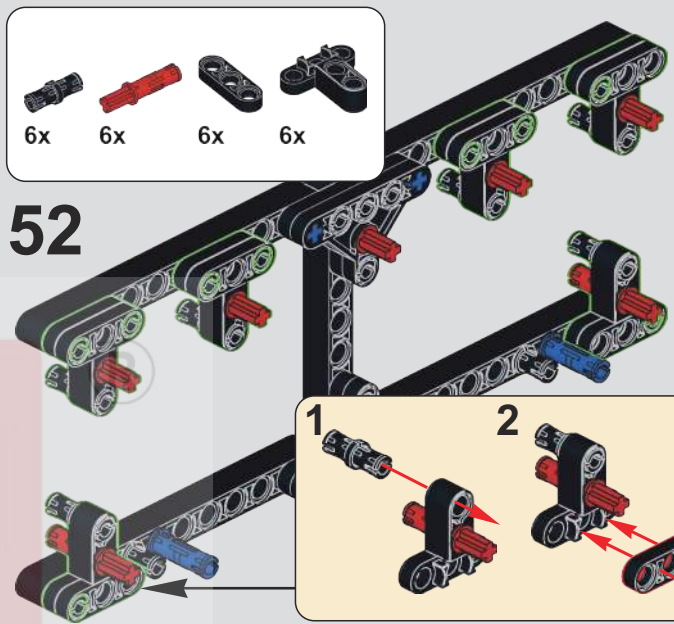

53

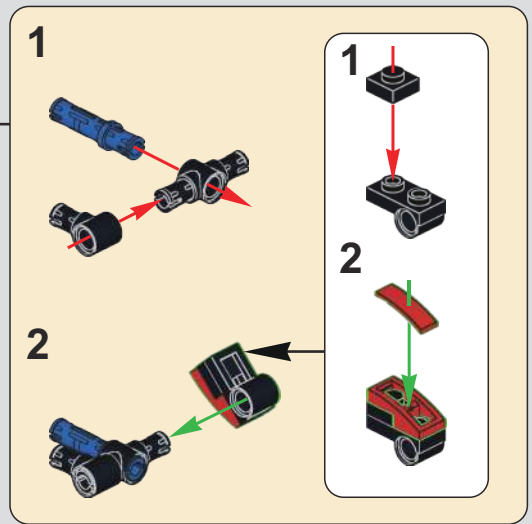
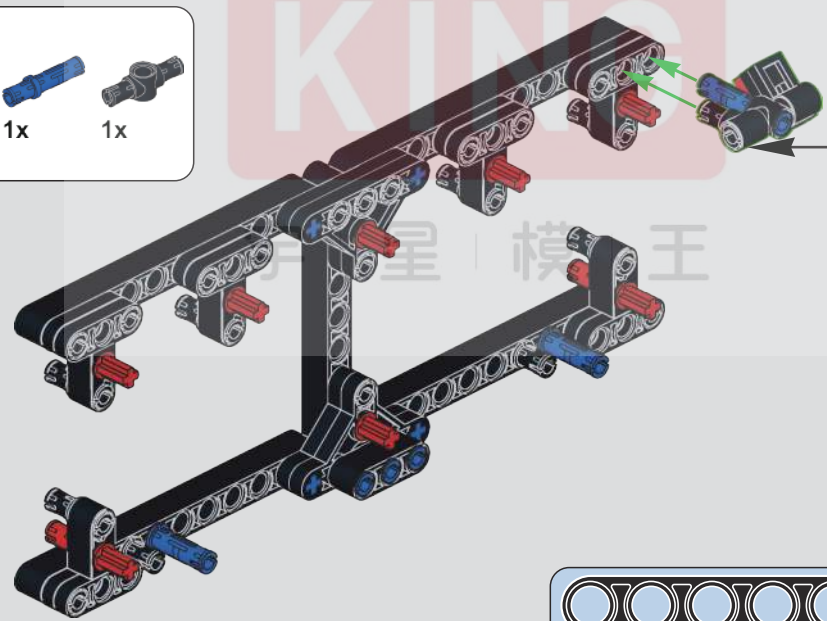

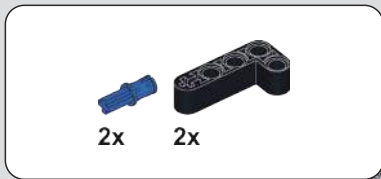

54

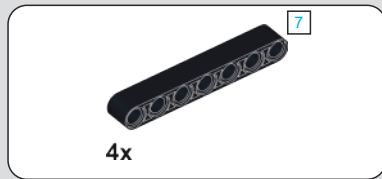
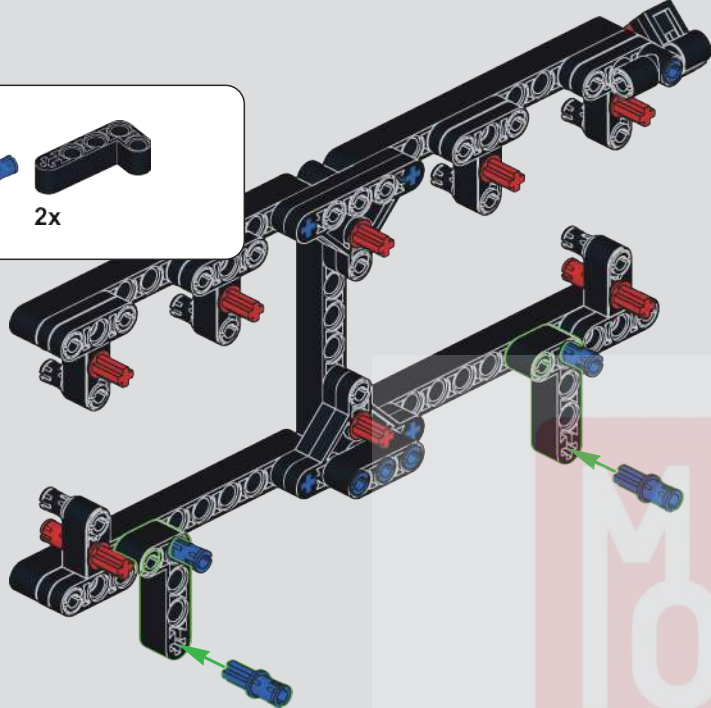

55

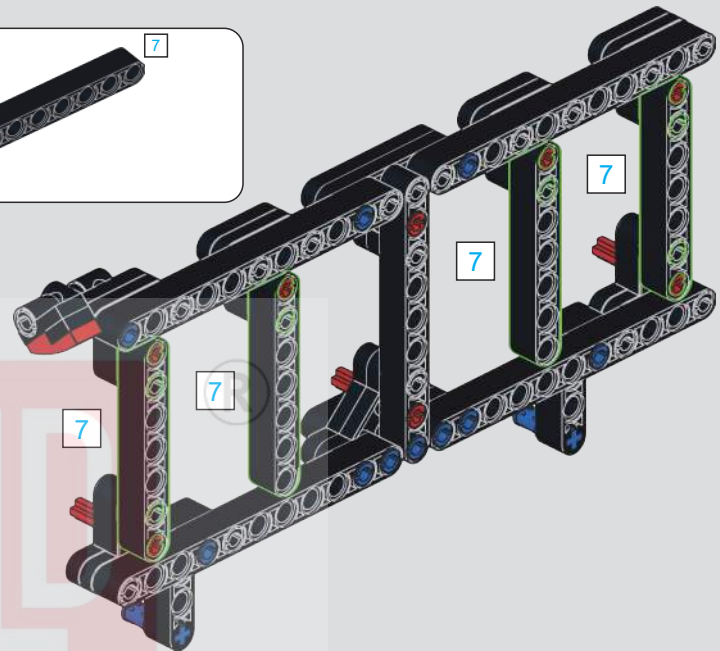

56

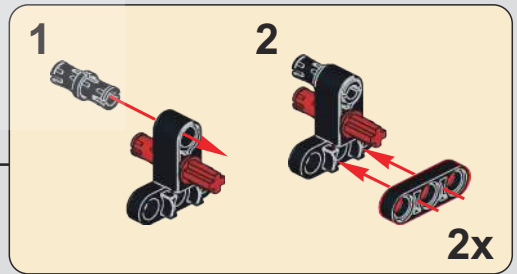
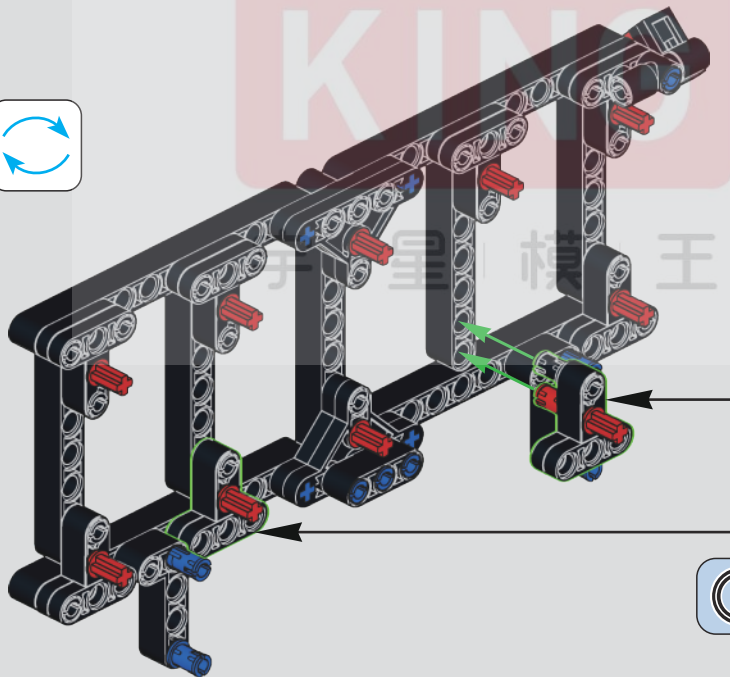



57

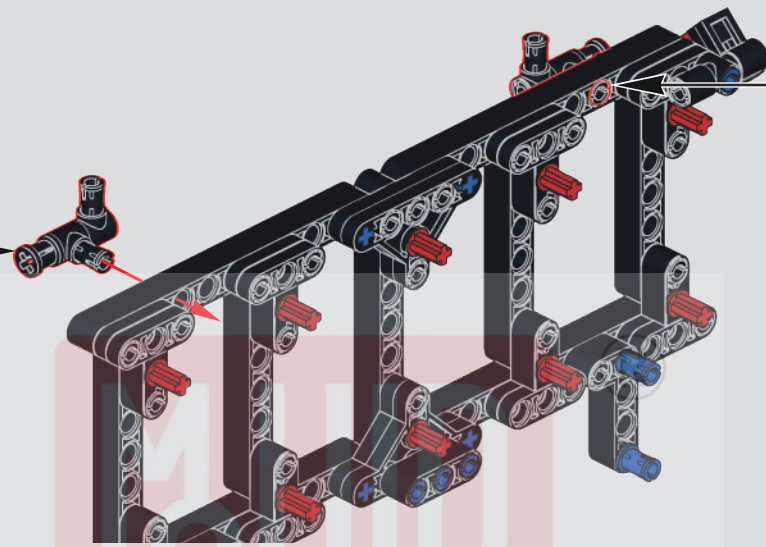
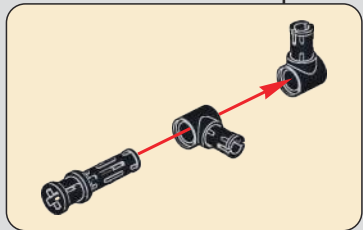

58

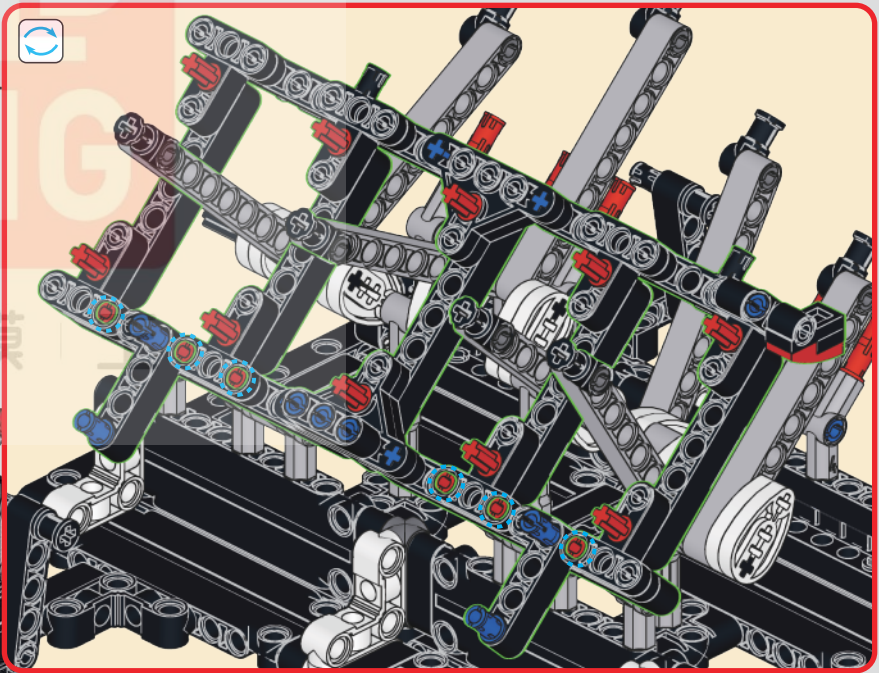
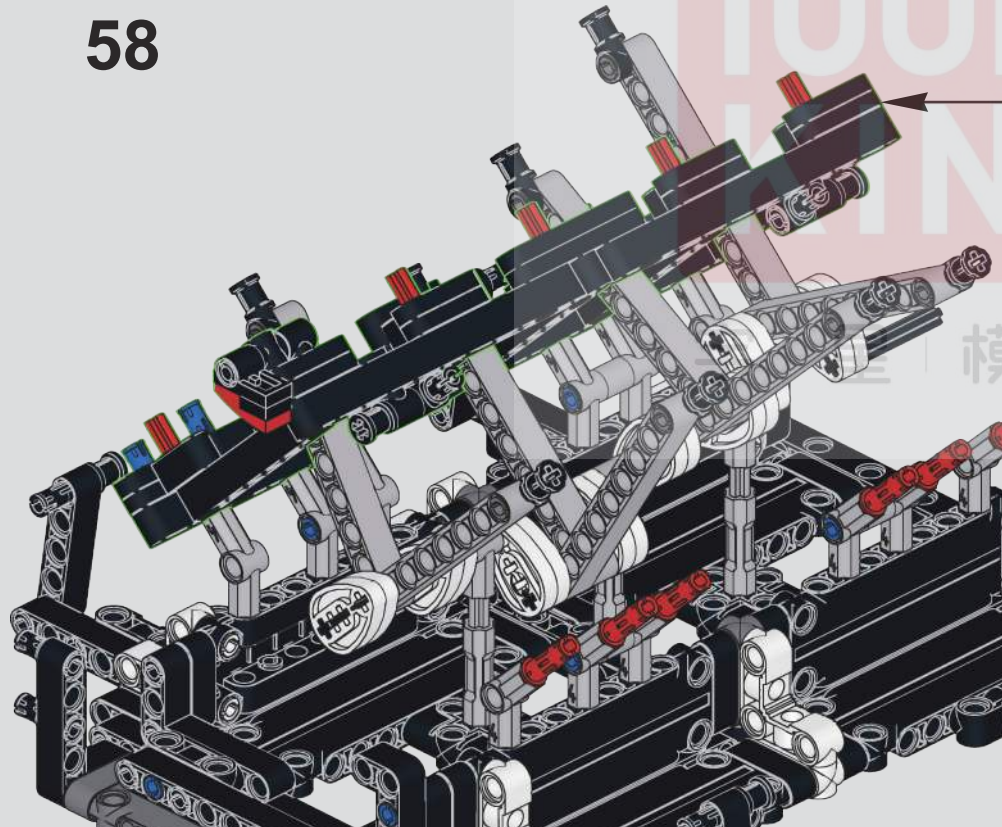

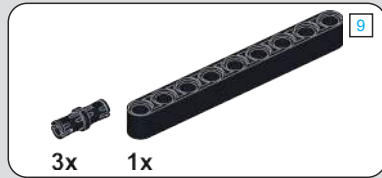
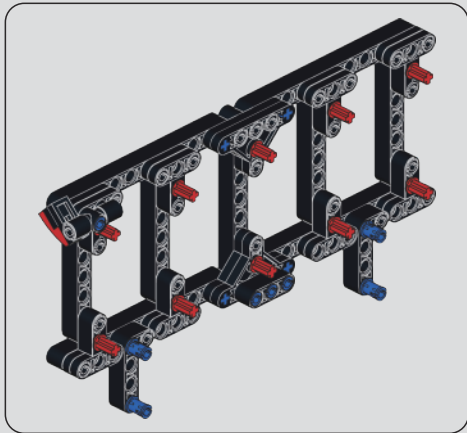

59

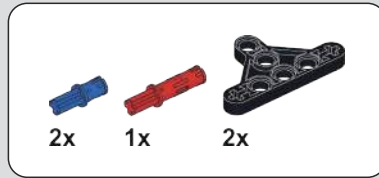
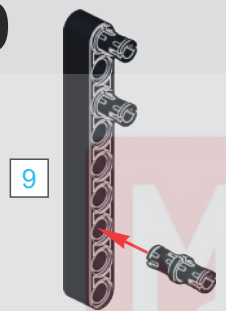

60

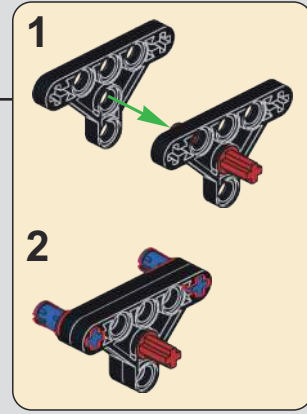
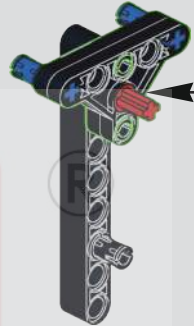

61

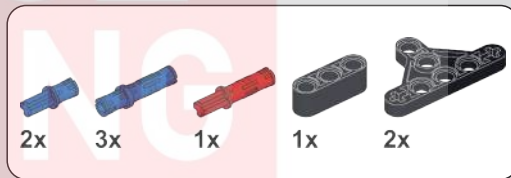
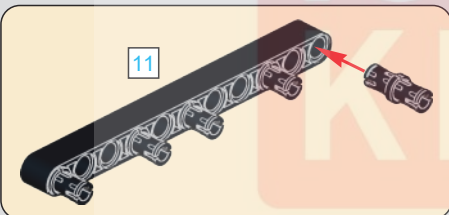

62

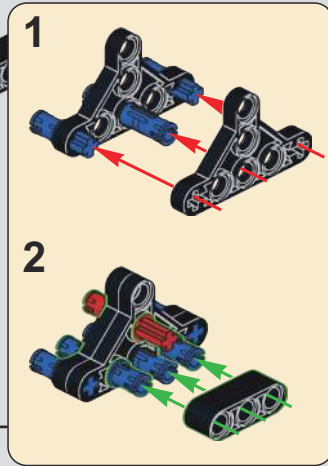
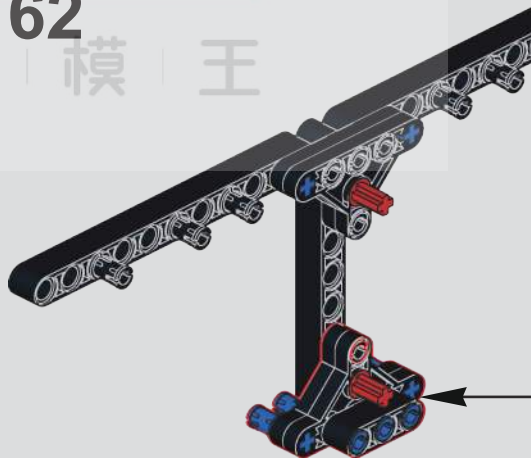

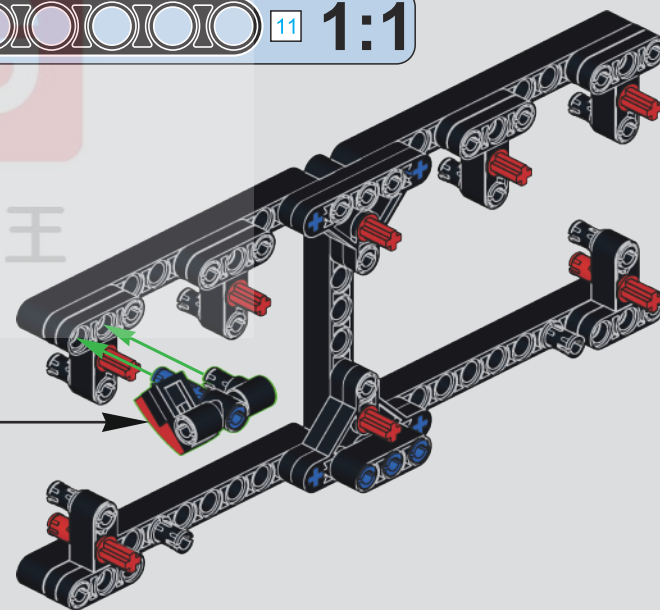
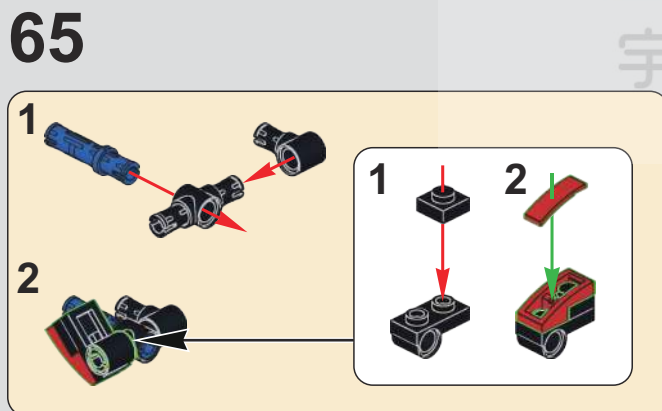
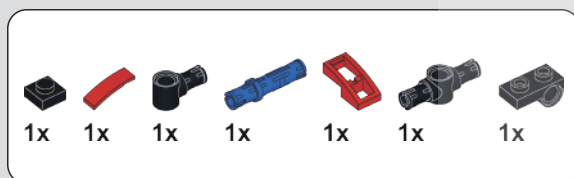
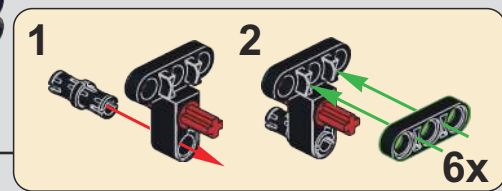
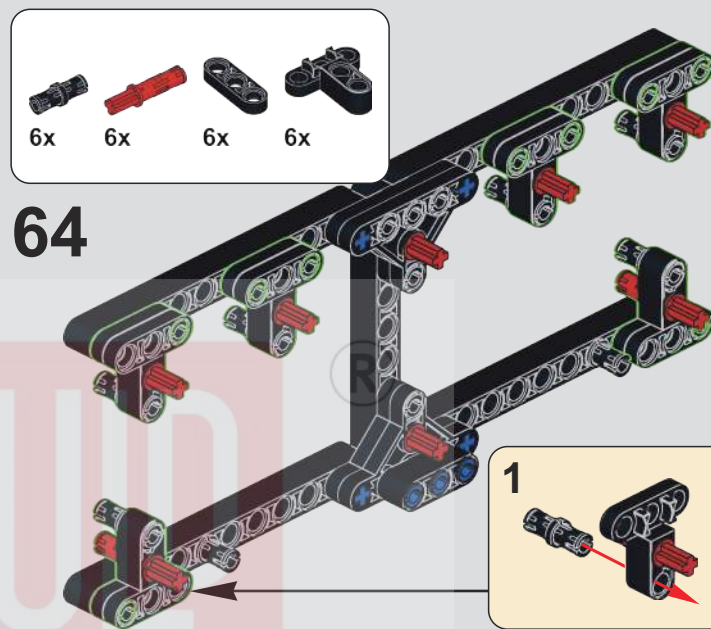
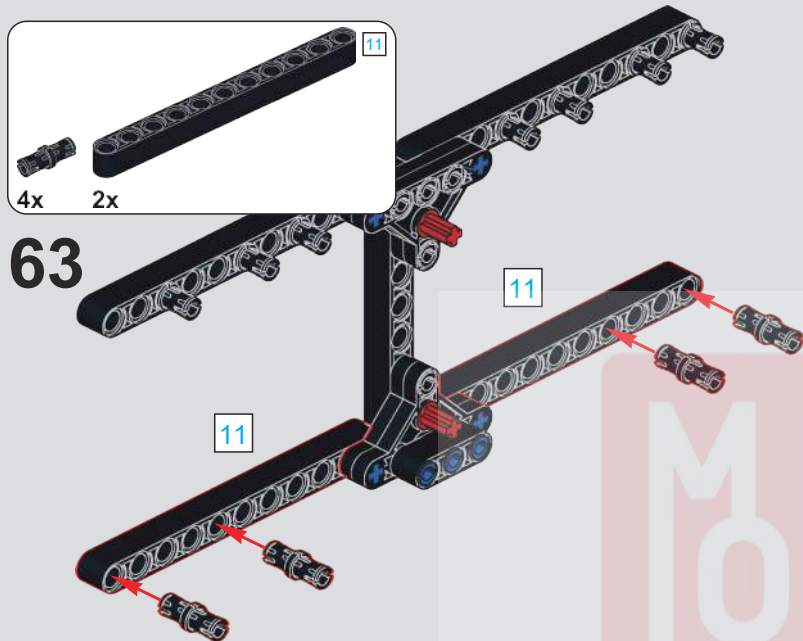

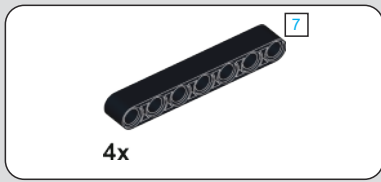

66

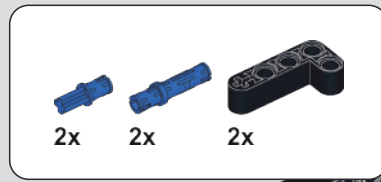
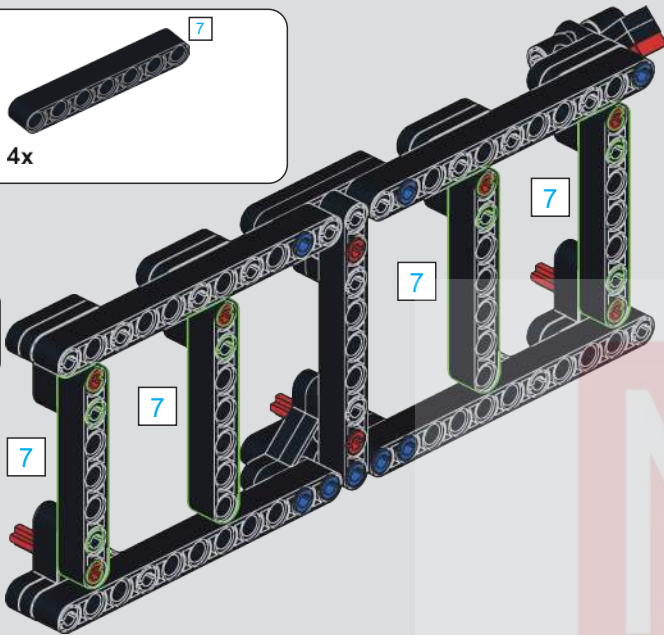

67

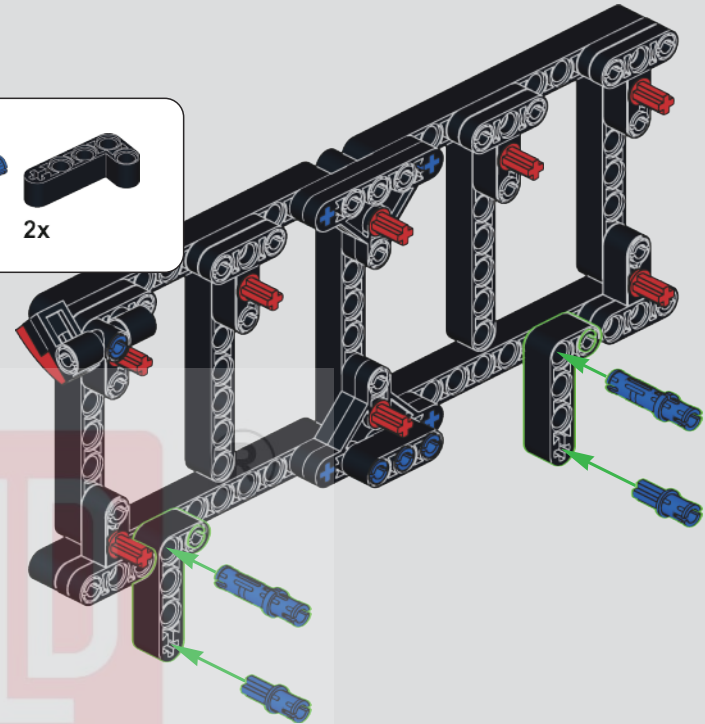

68

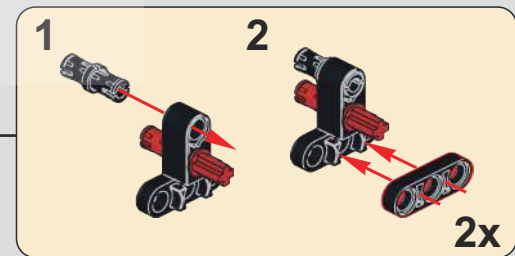
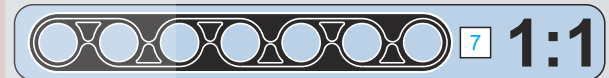
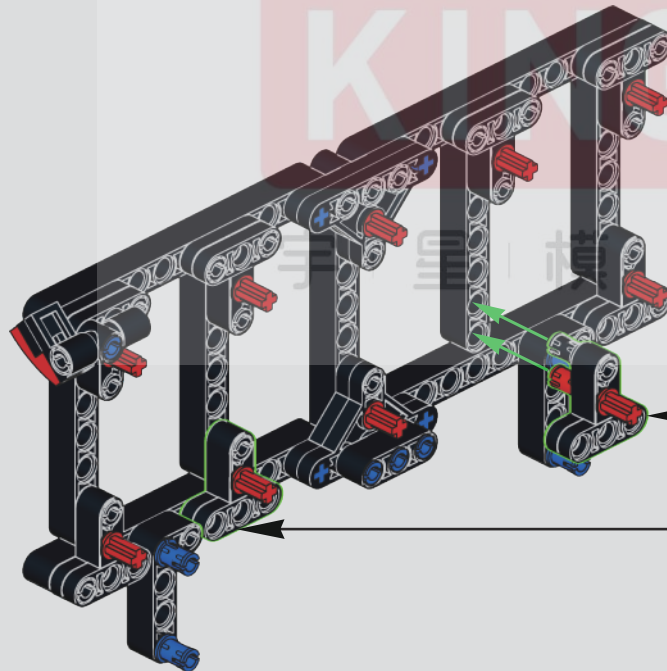

69

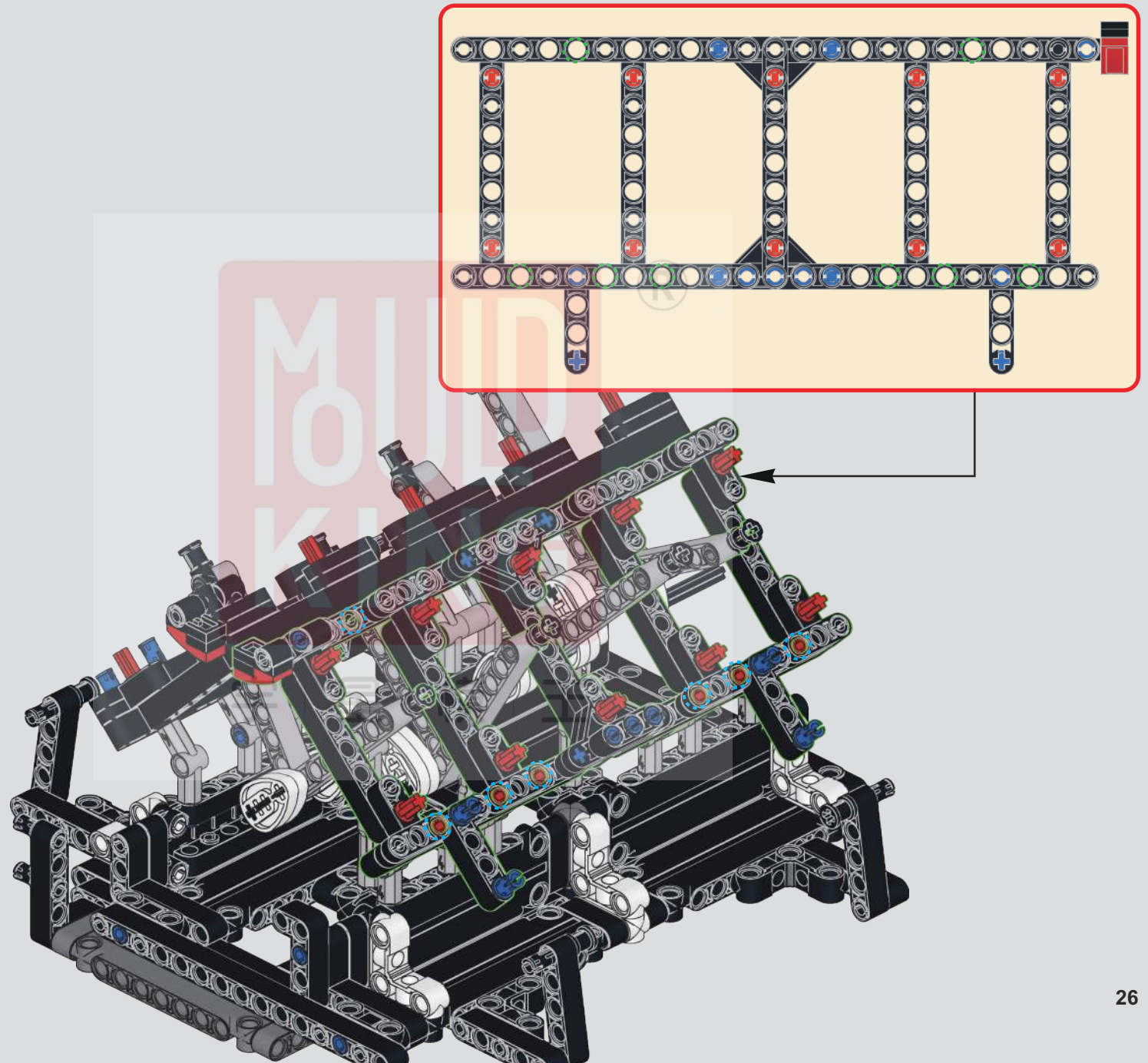

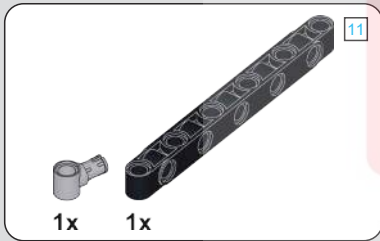
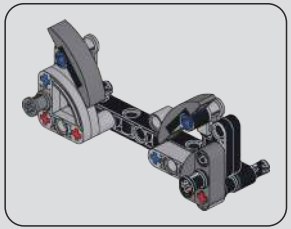
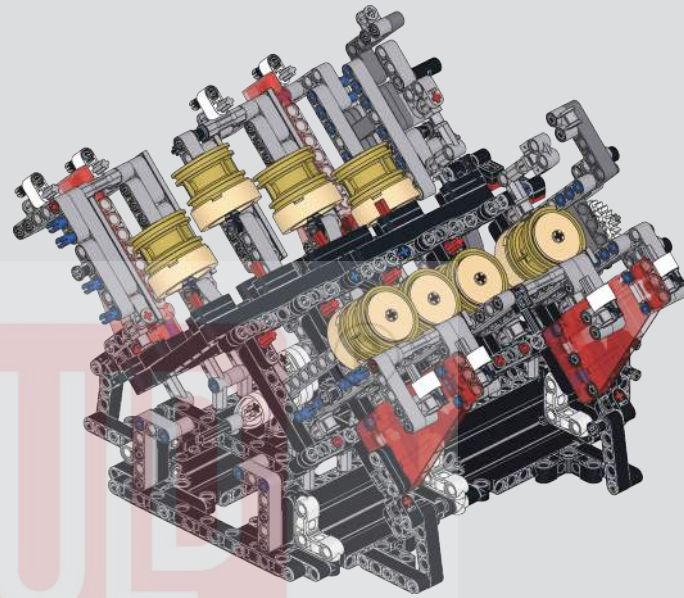

70

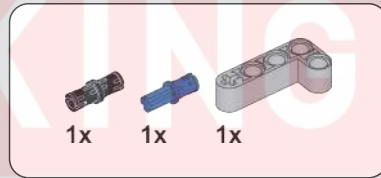

71



72

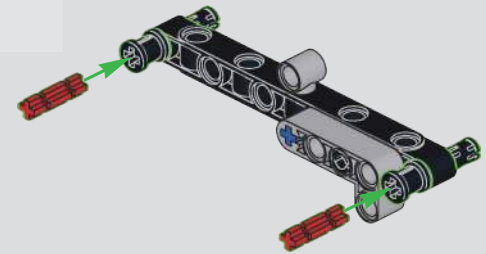
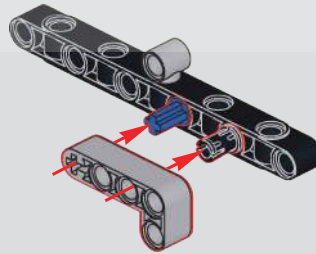
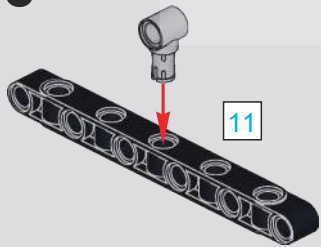

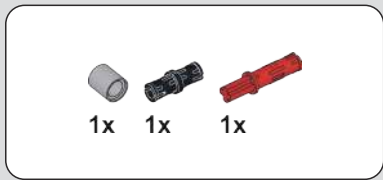

73

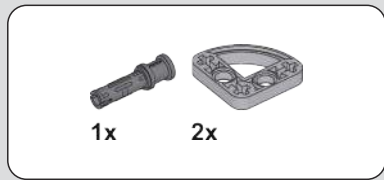
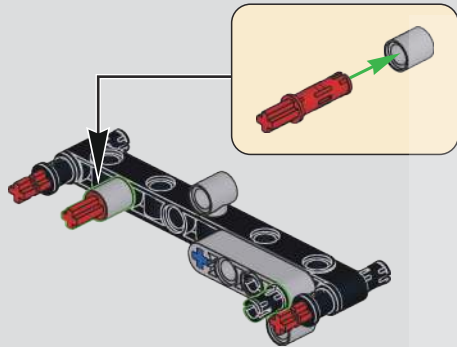

74

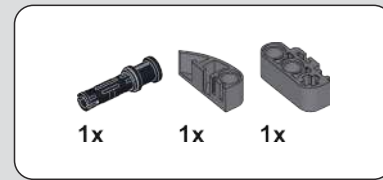
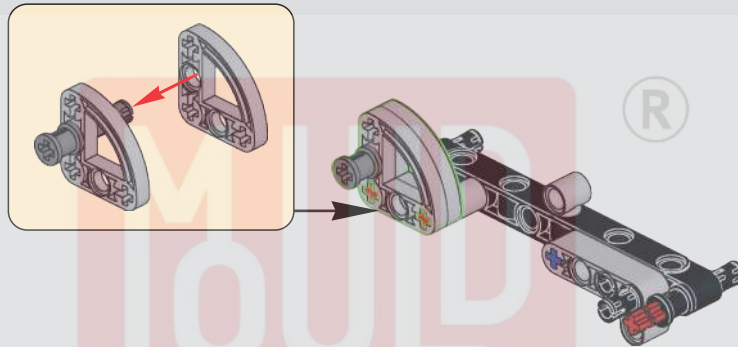

75

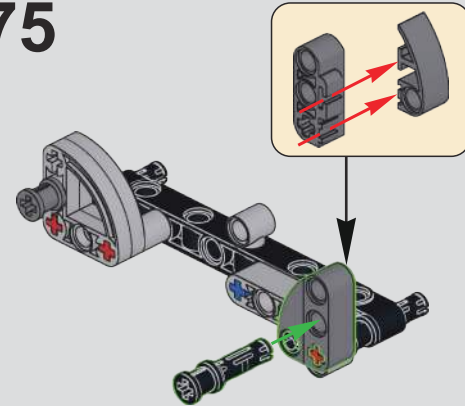

76

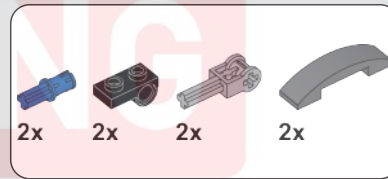
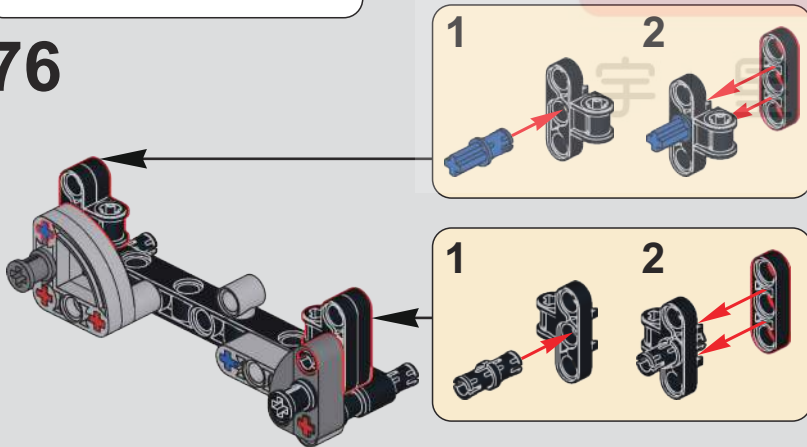

77

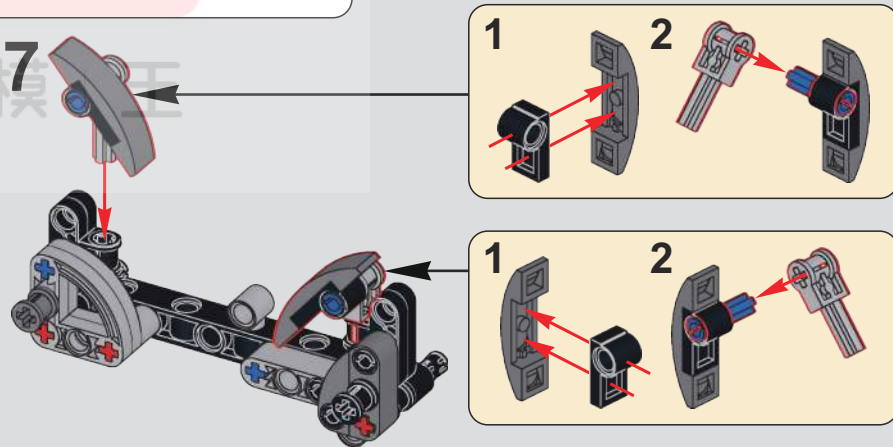

78

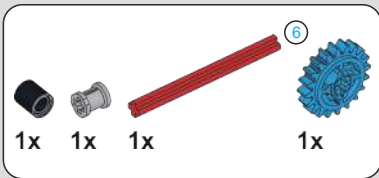
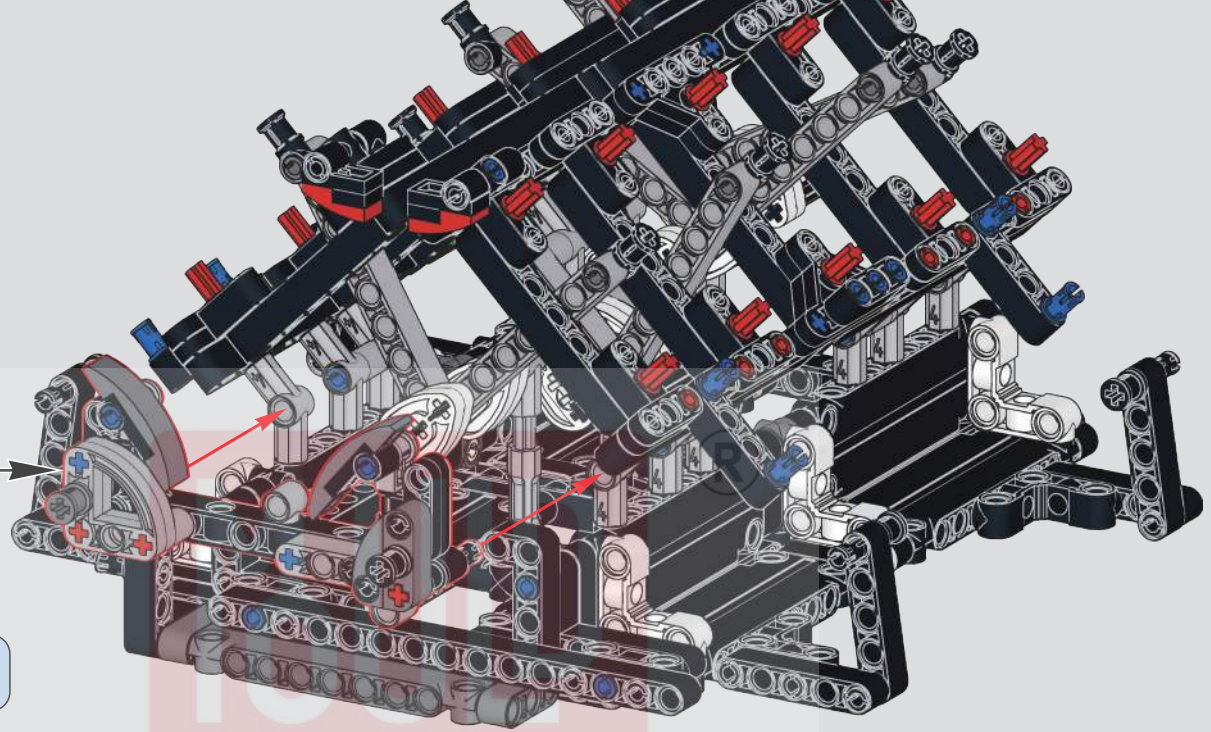
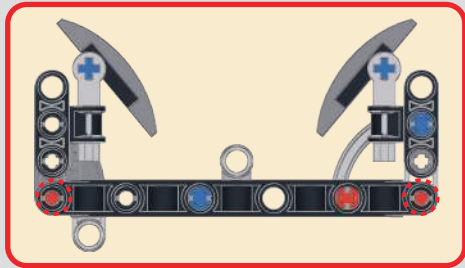

79

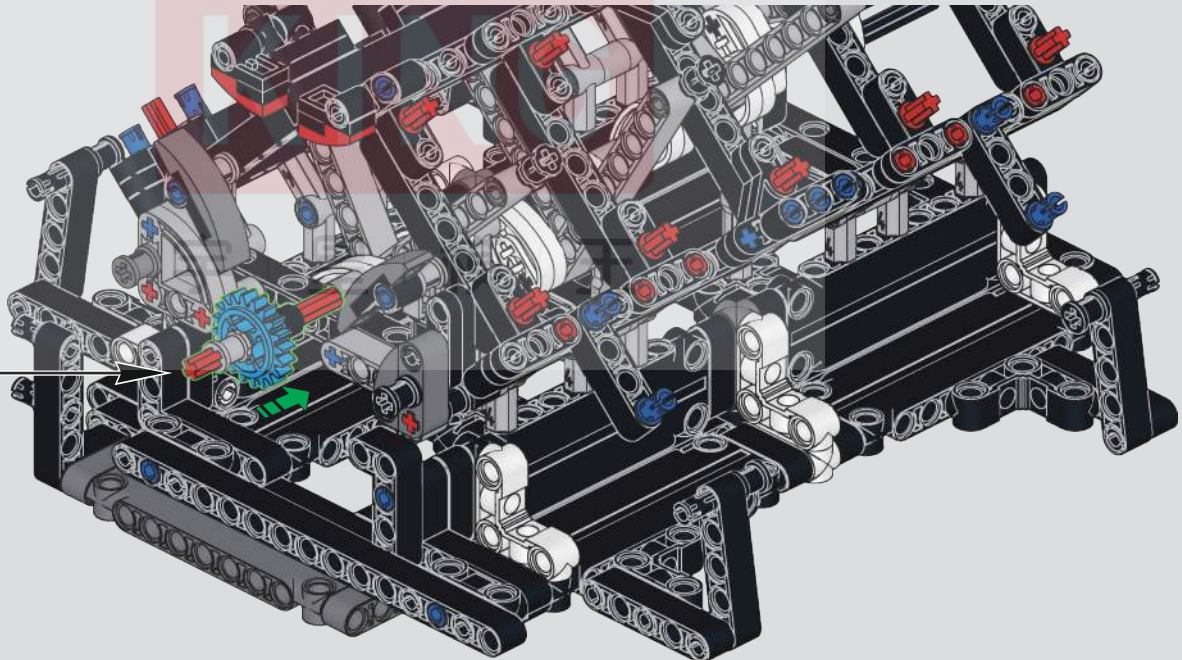
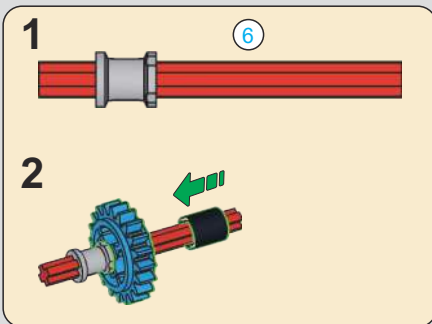

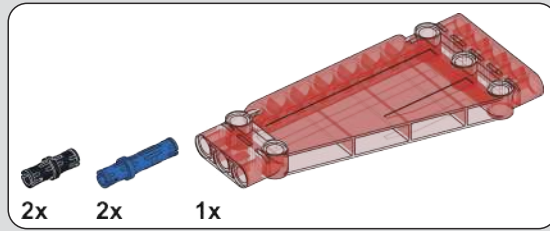
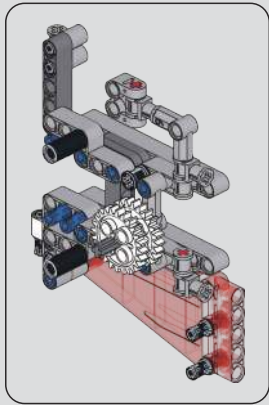

80

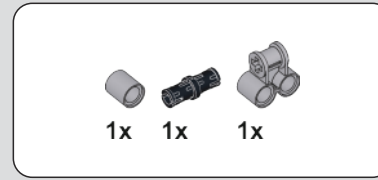

81

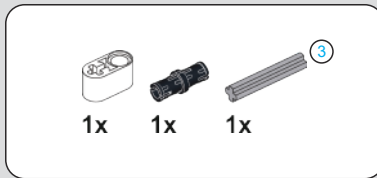
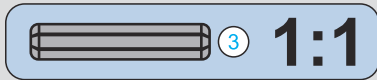
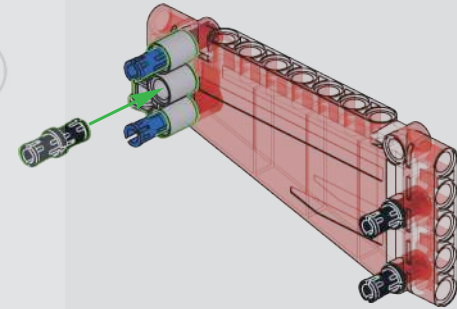
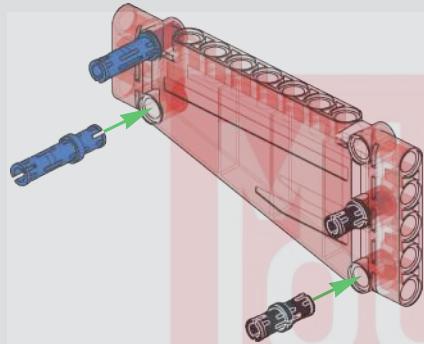

82

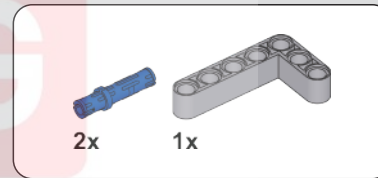

83

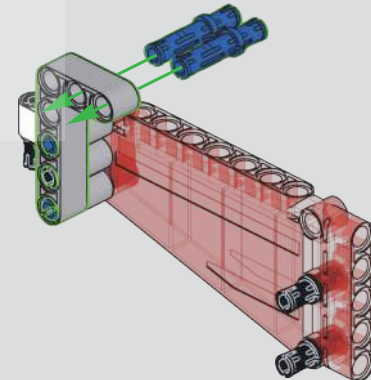
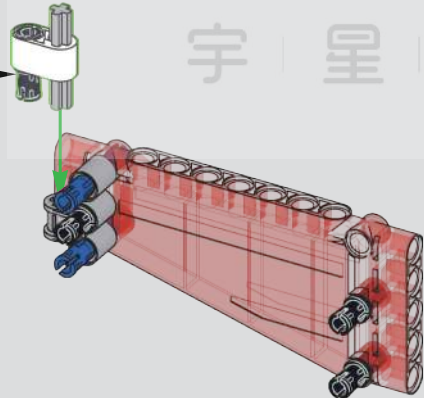
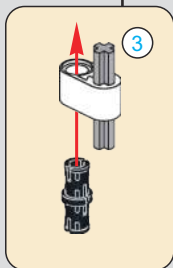

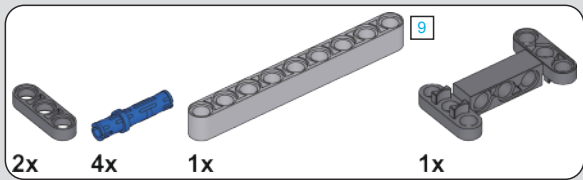

84

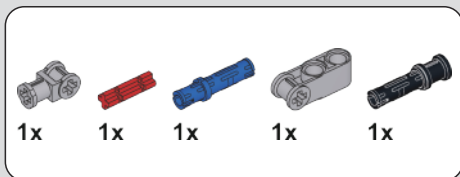
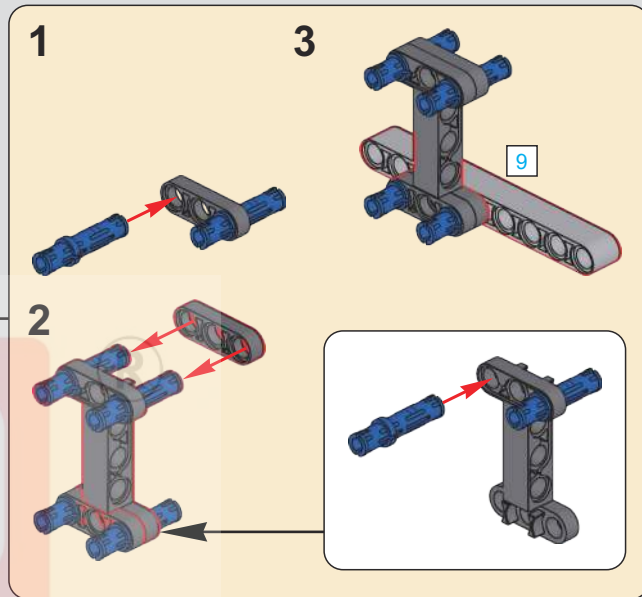
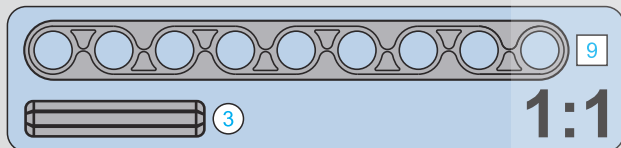
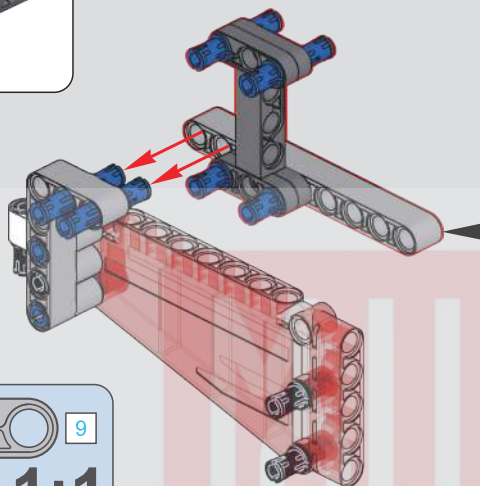

85

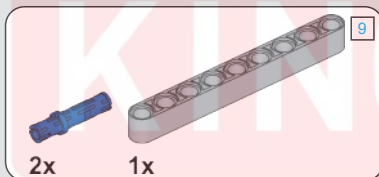
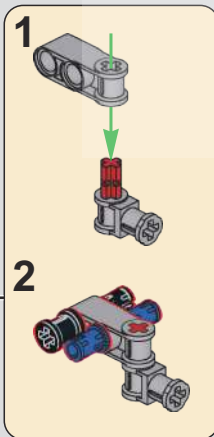
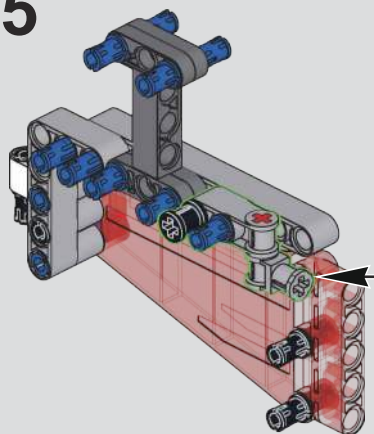

86

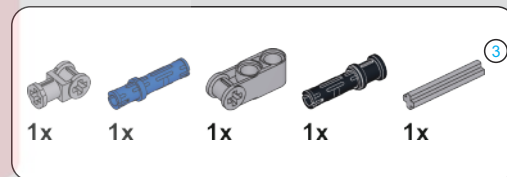
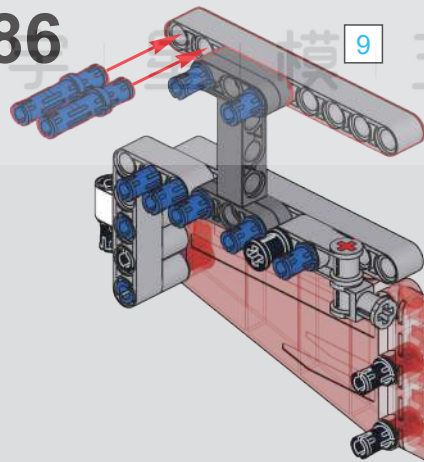

87

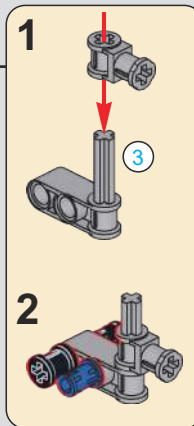
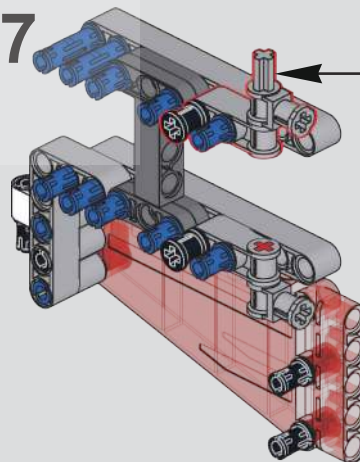

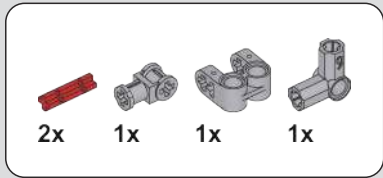

88

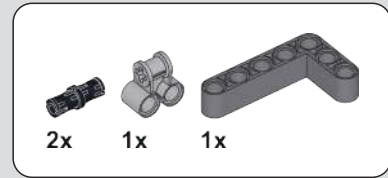
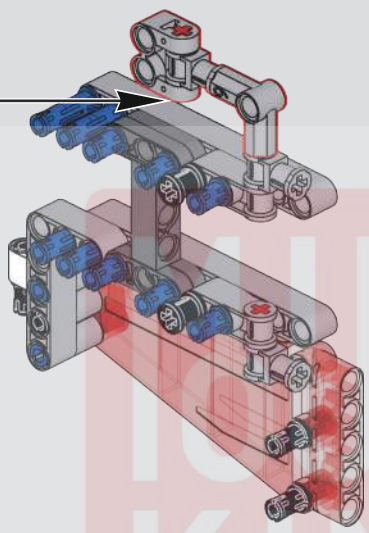
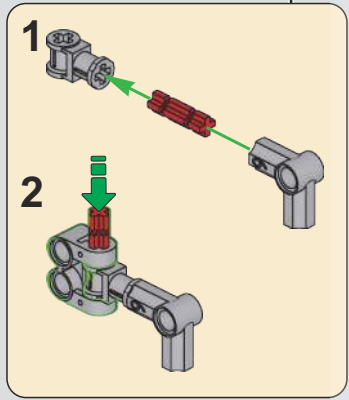

89

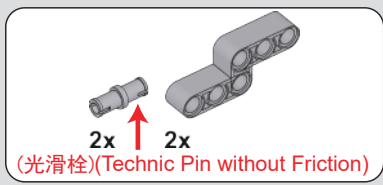
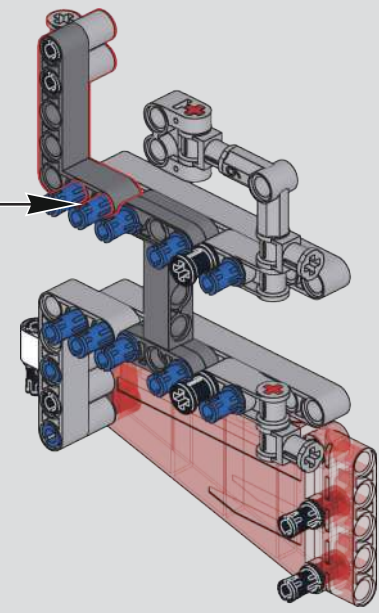
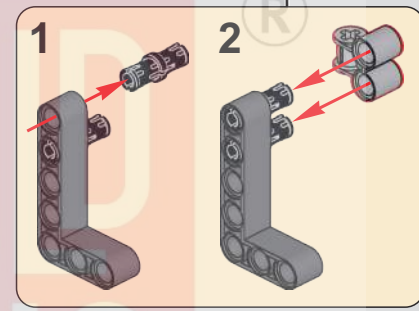

90

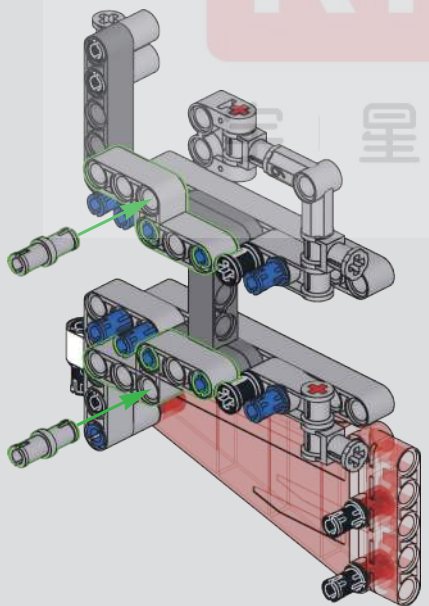
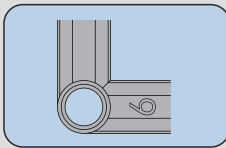

91

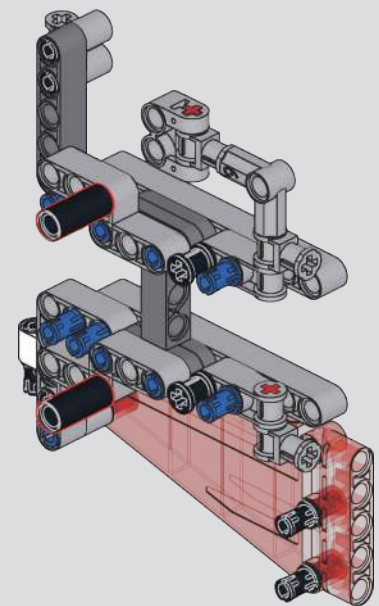

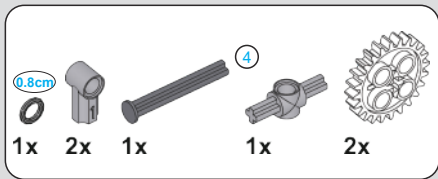

92

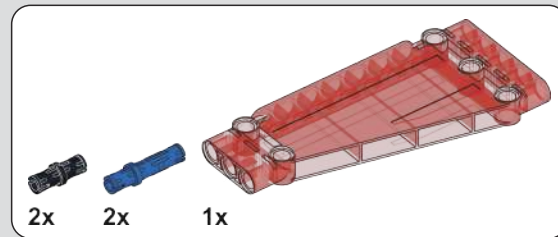
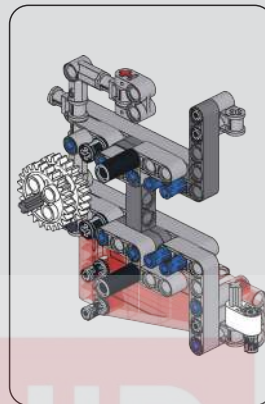
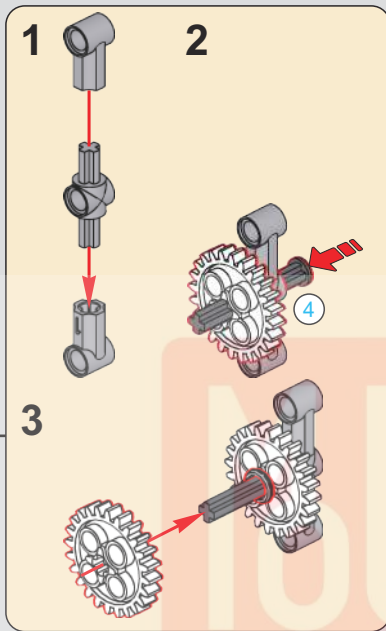
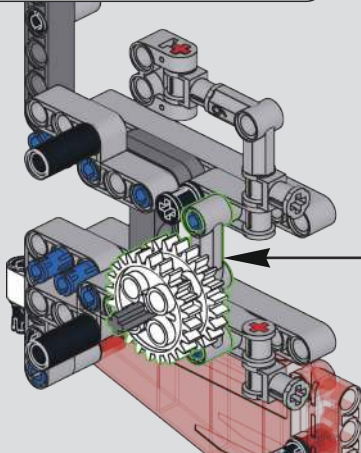

93

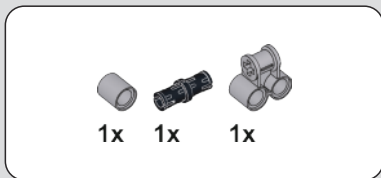
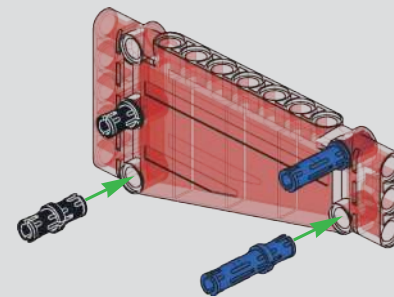

94

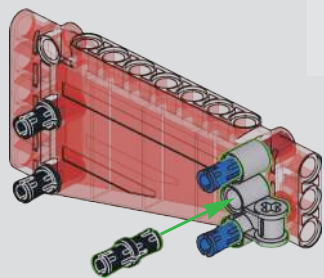

95

宇星模

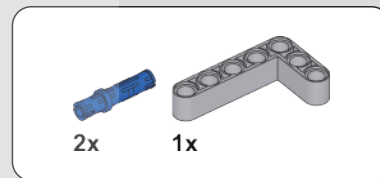
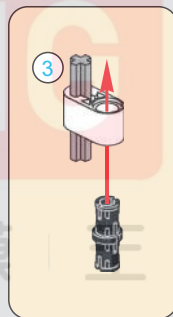
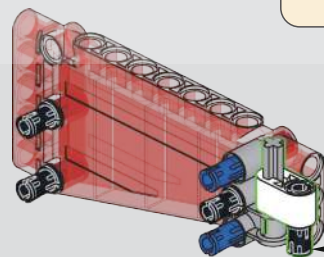

96

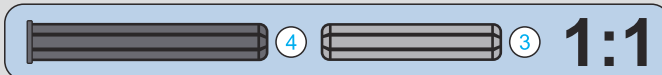
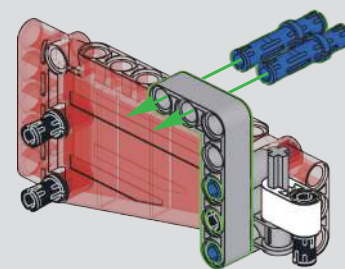

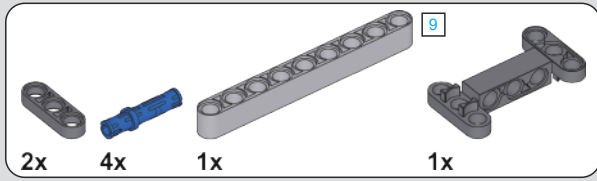

97

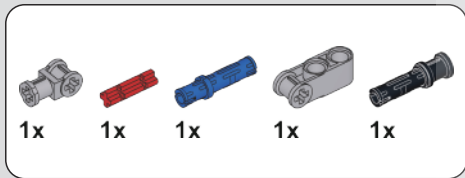
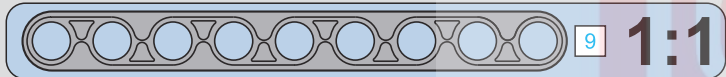
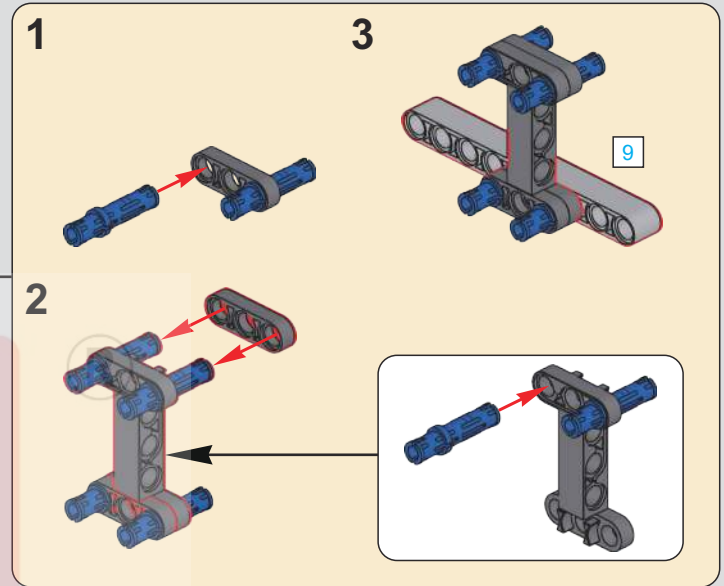
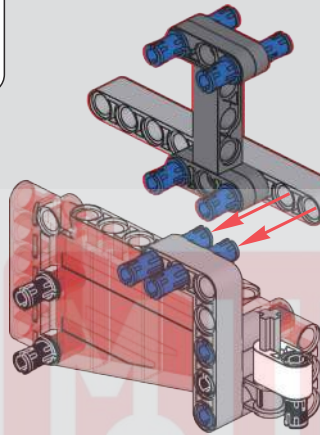

98

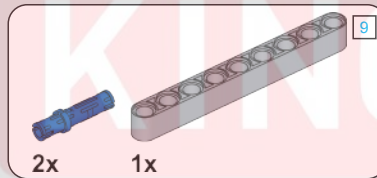
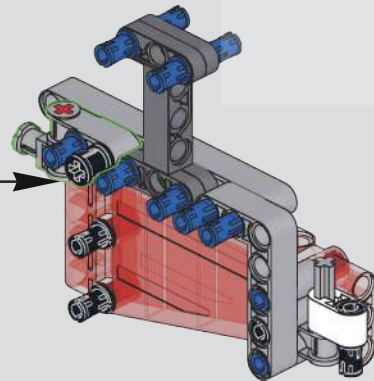
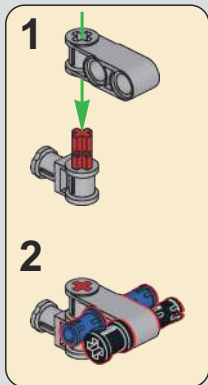

99

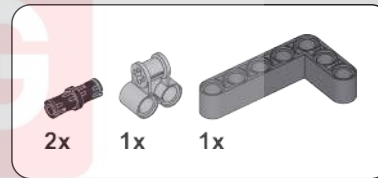
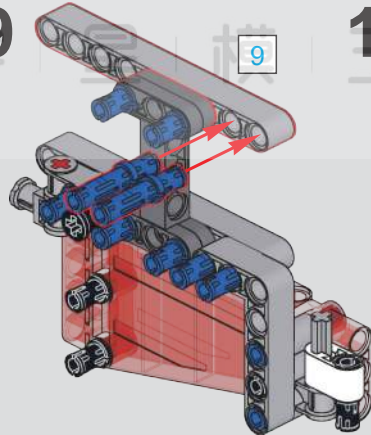

100

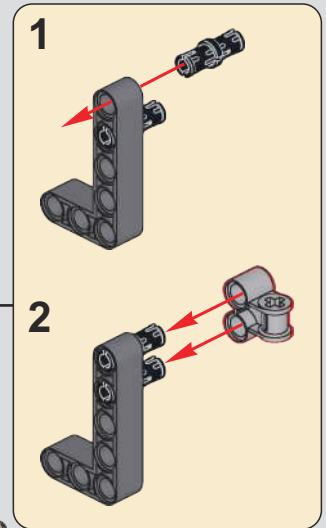
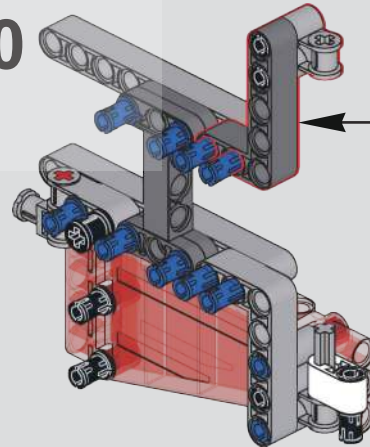

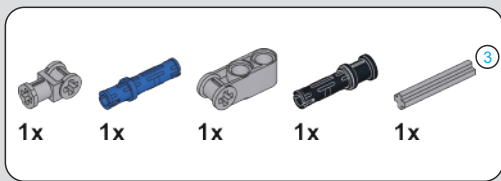

101

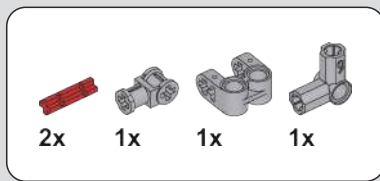
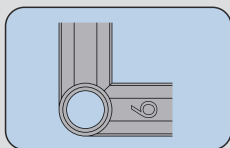
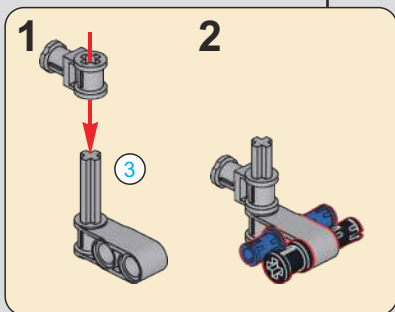

102

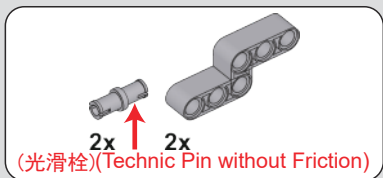
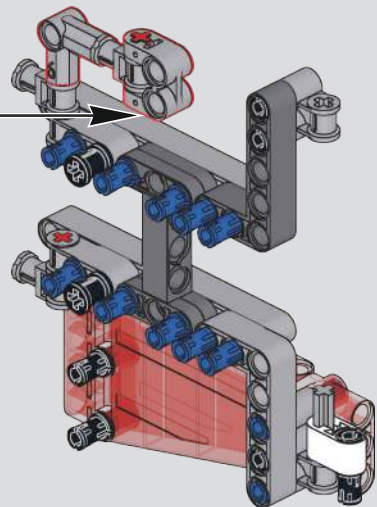
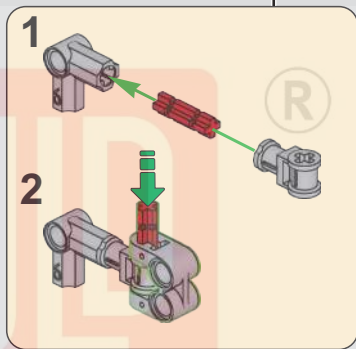

103

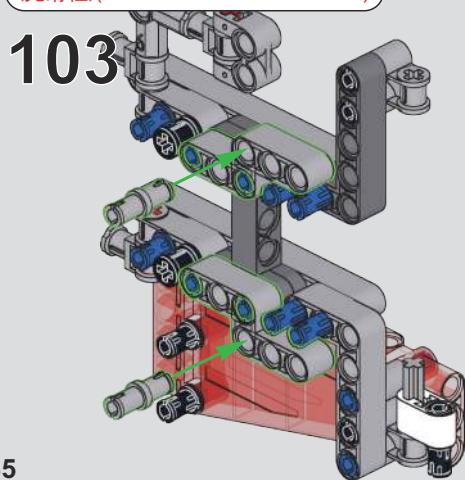

104

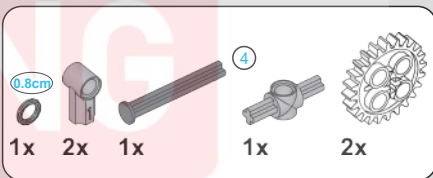
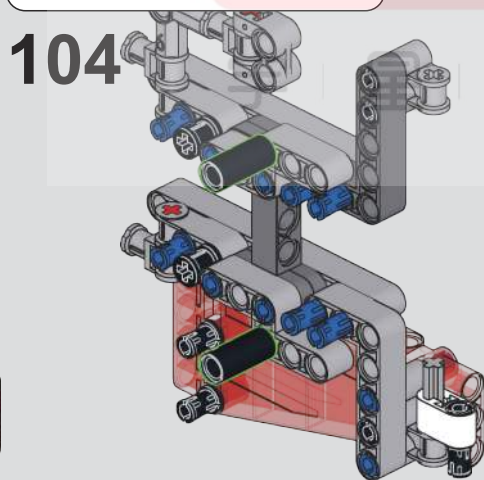

105

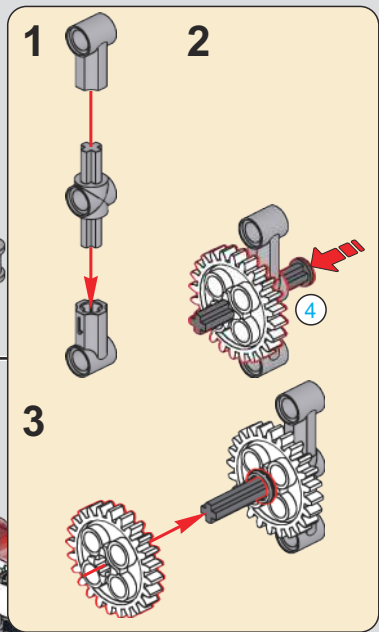
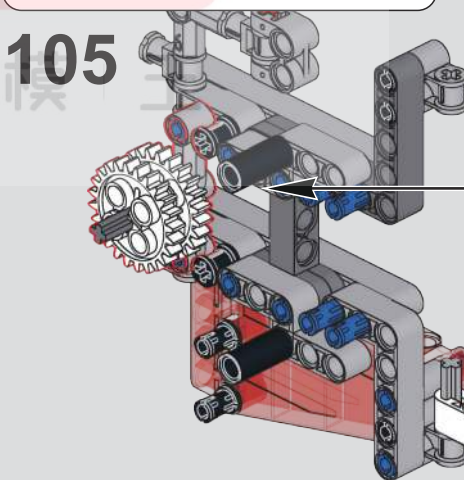

106

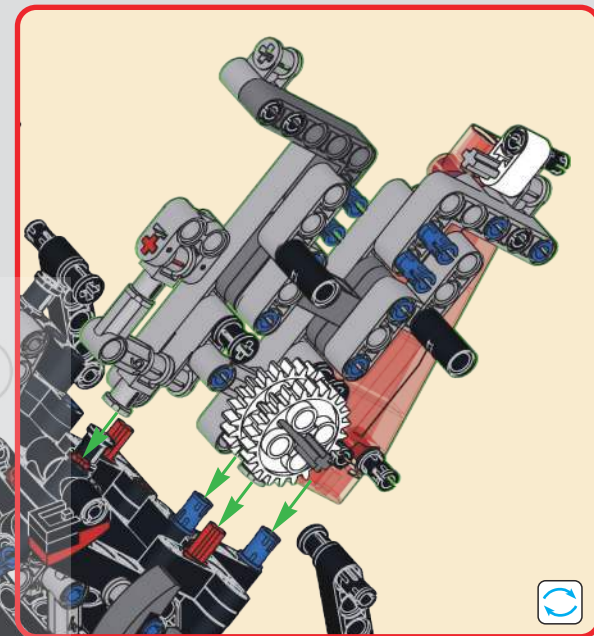
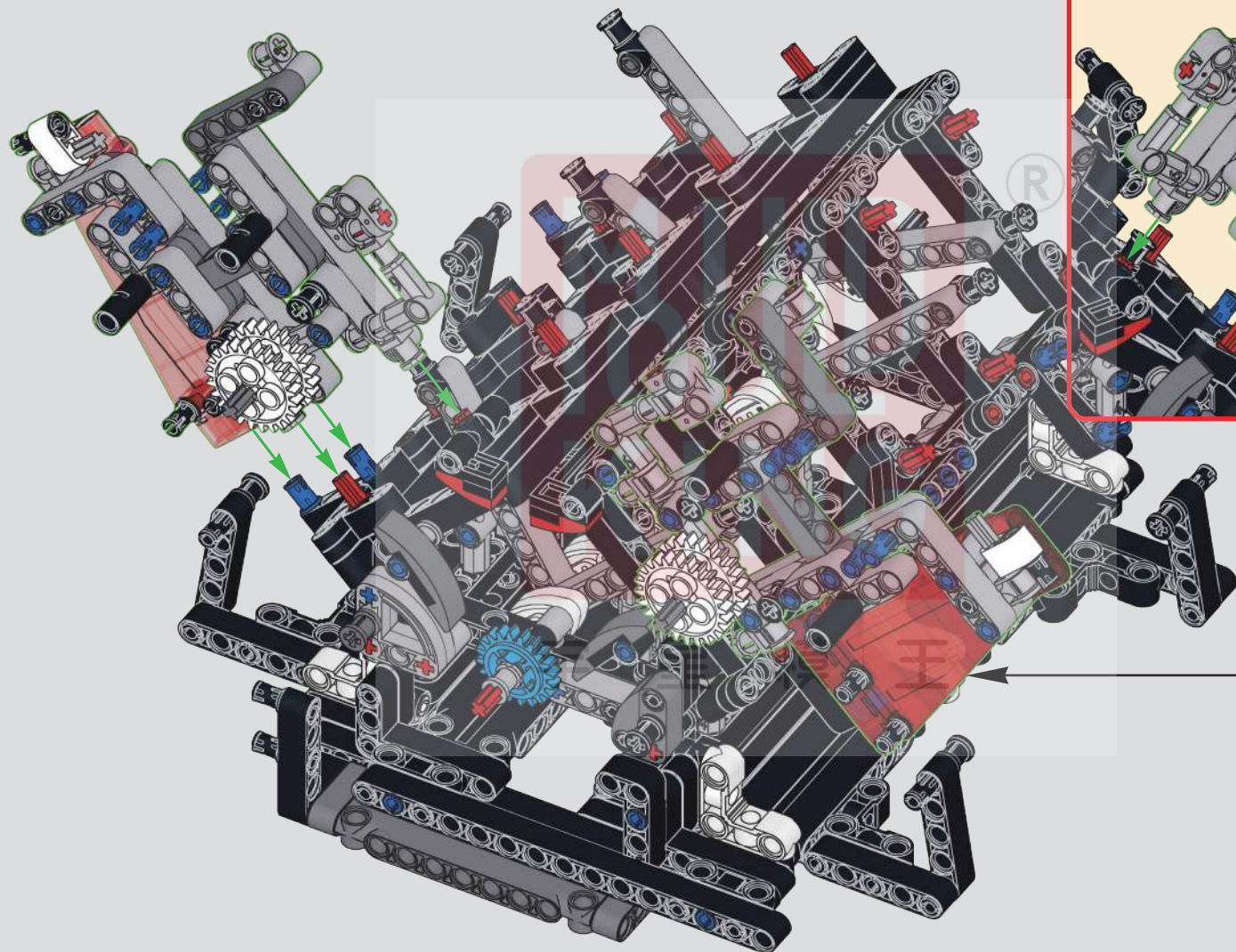

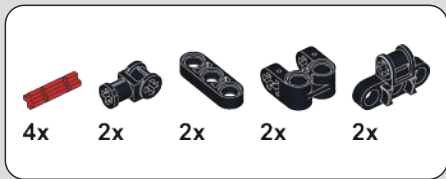

107

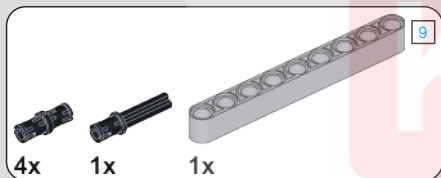
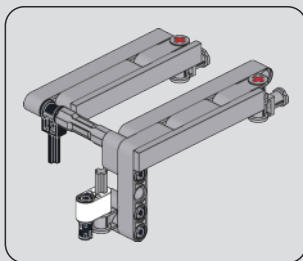
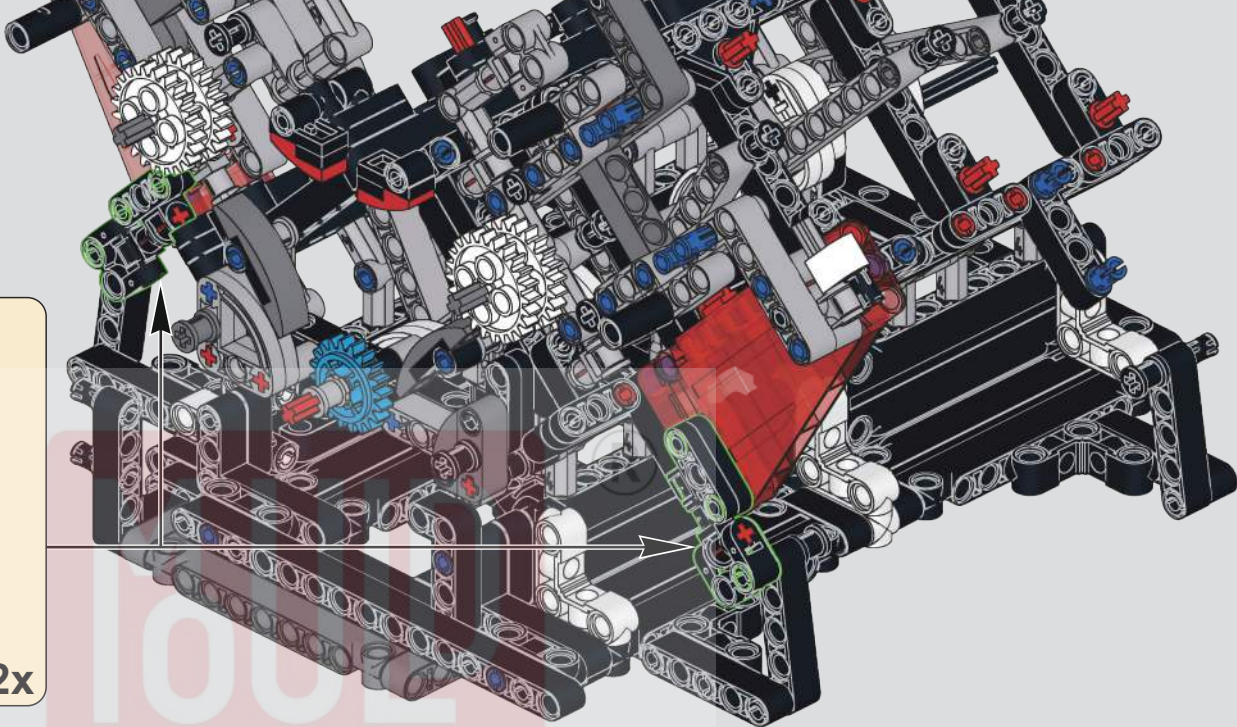
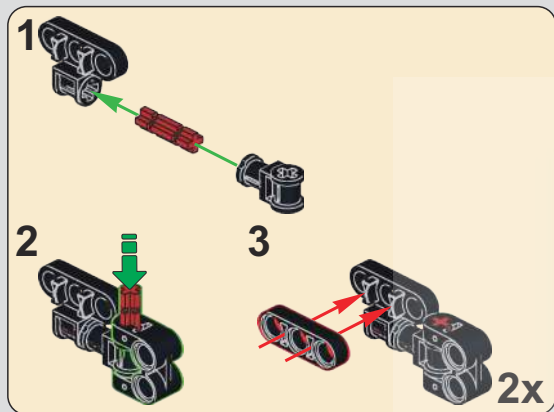

108

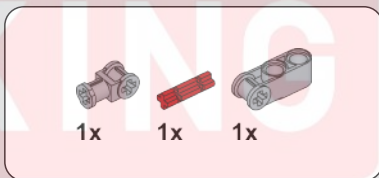
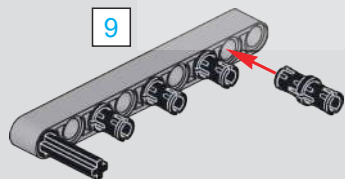

109

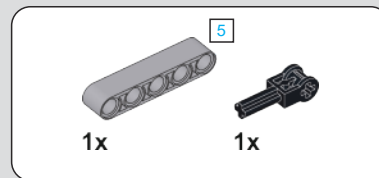
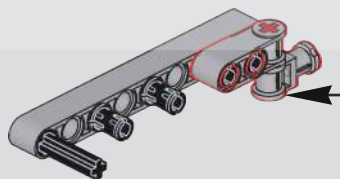

110

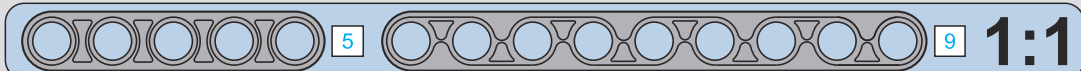
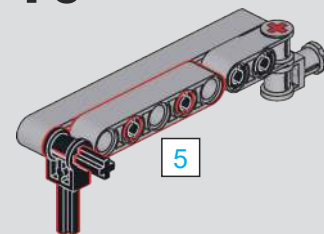
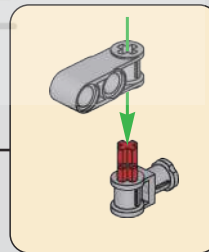

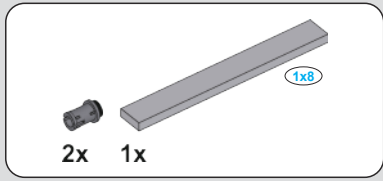

111

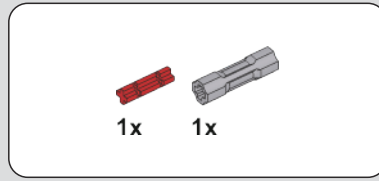
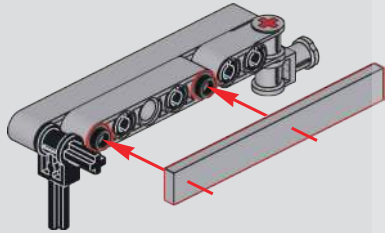

112

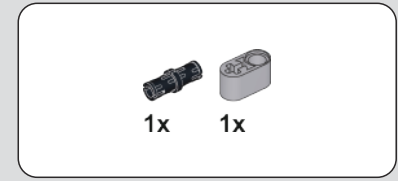
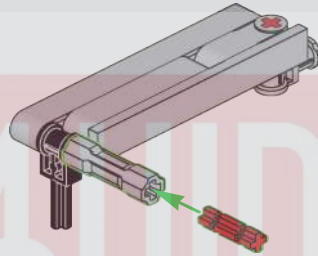

113

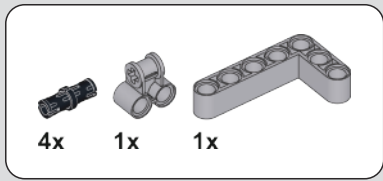
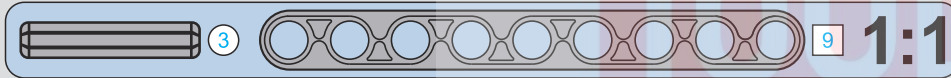
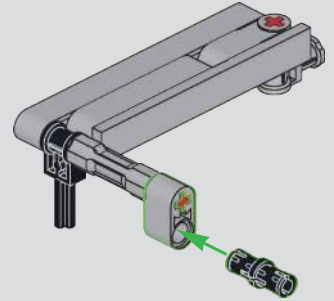

114

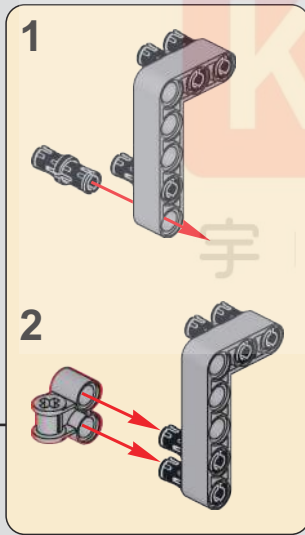
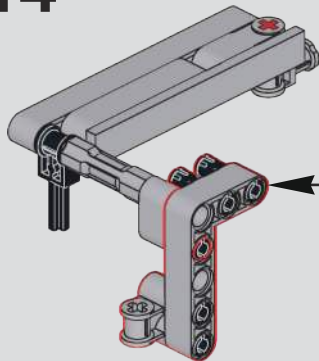

115

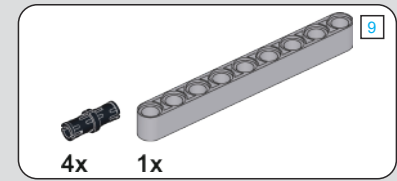
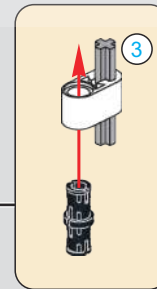
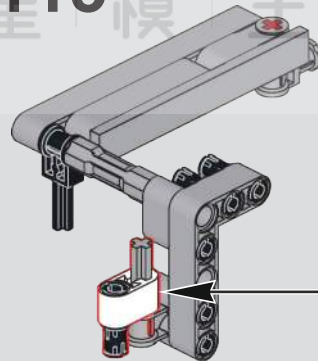

116

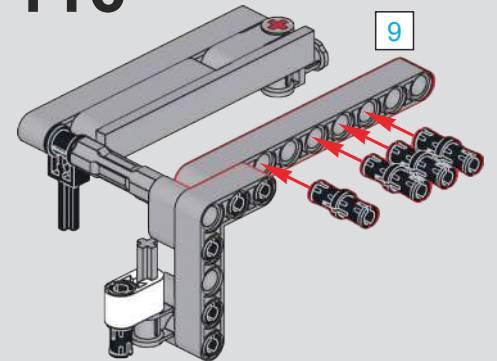

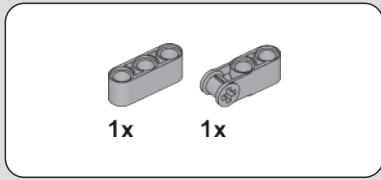

117

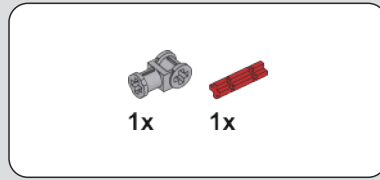
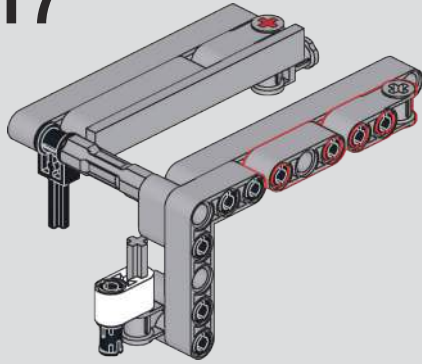

118

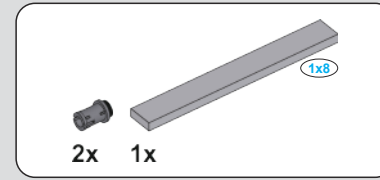
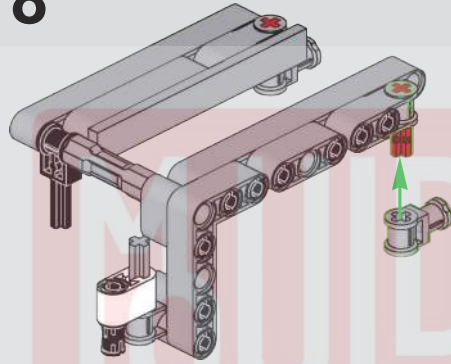

119

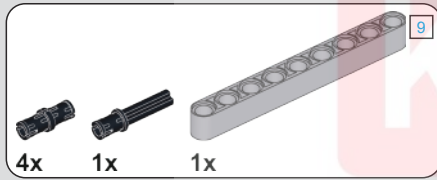
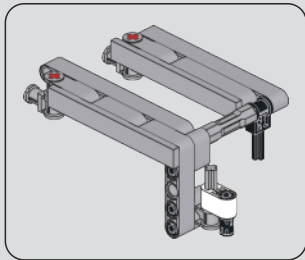
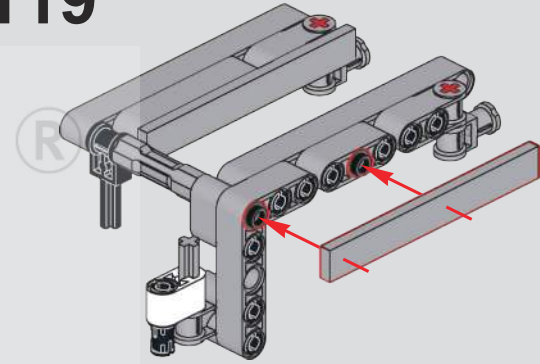

120

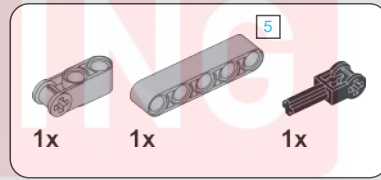
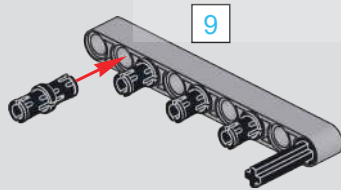

121

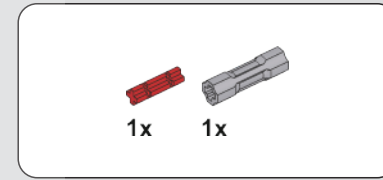
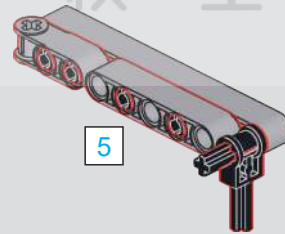

122

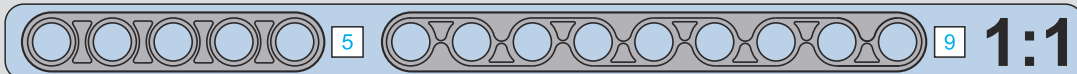
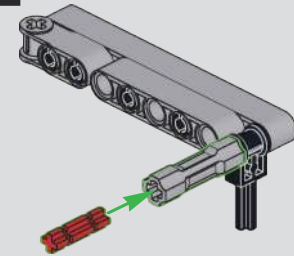

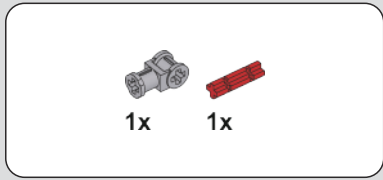

123

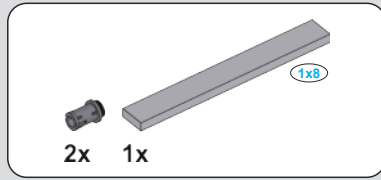
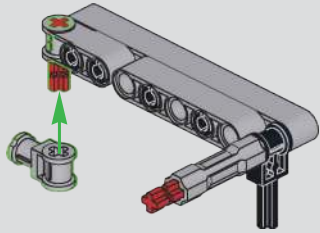

124

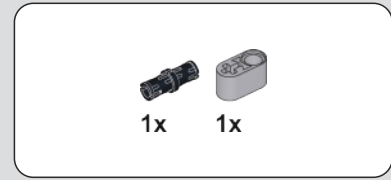
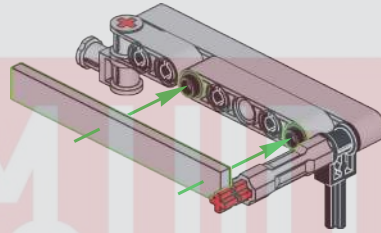

125

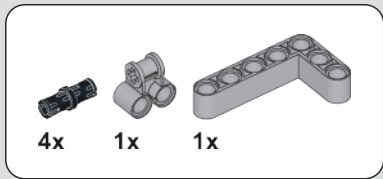
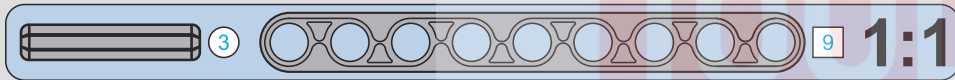
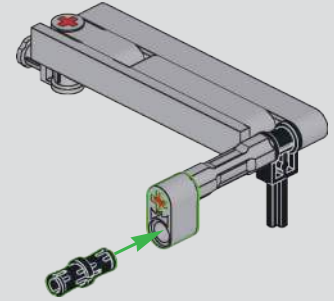

126

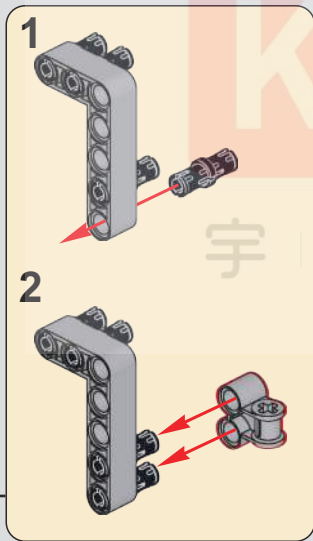
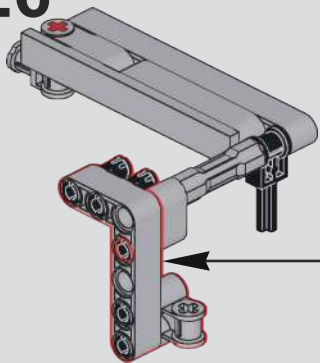

127

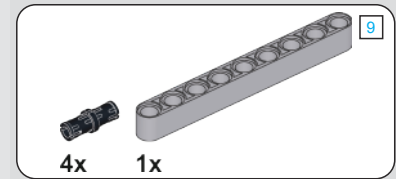
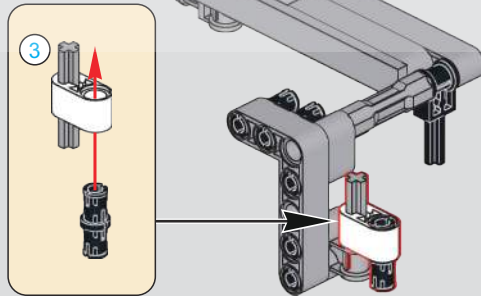

128

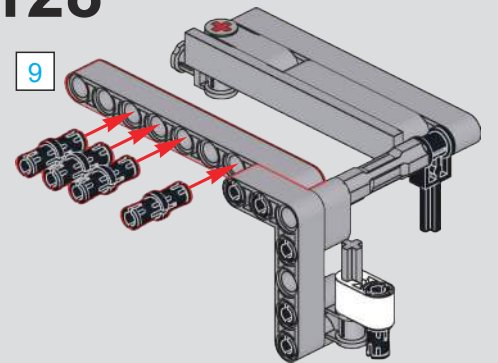

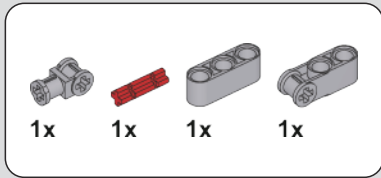

129

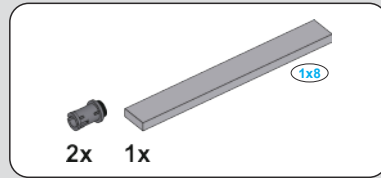
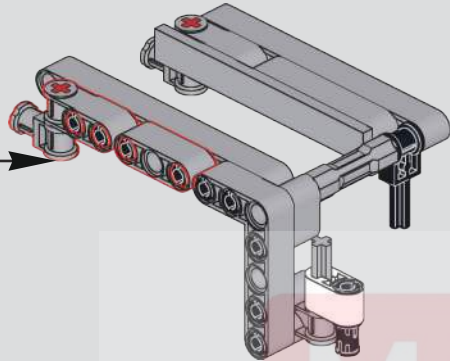
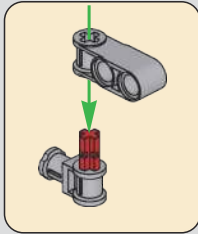

130

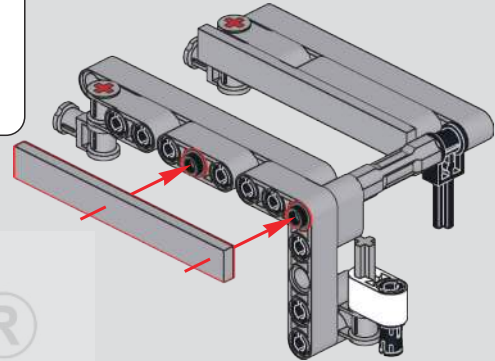

131

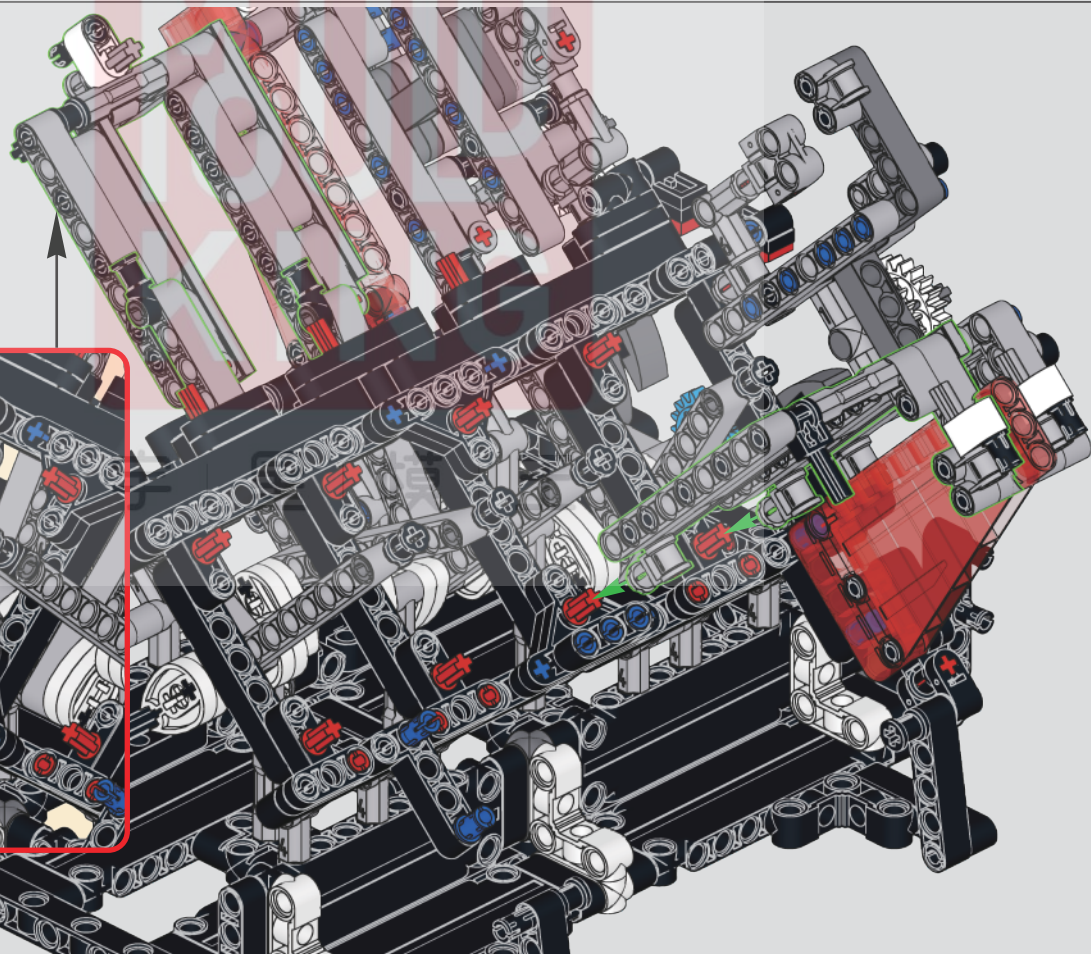
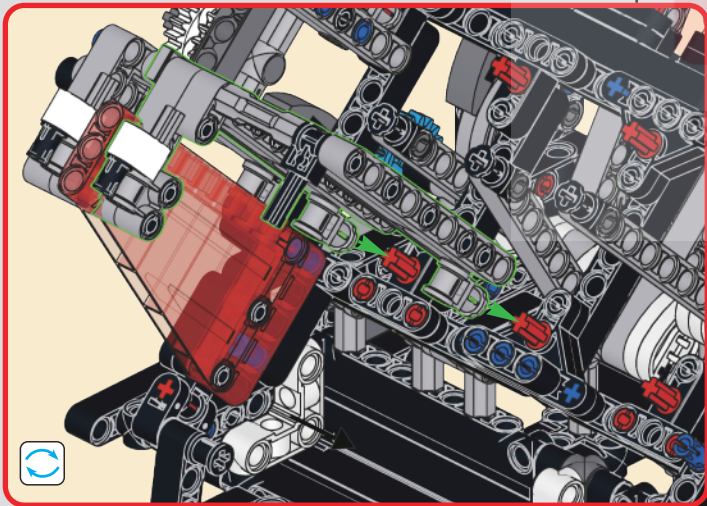

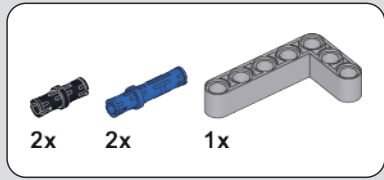
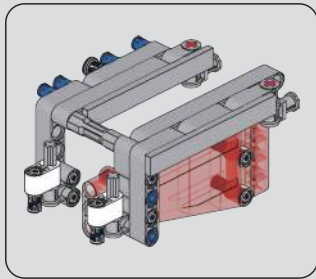

132

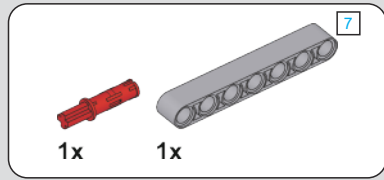

133

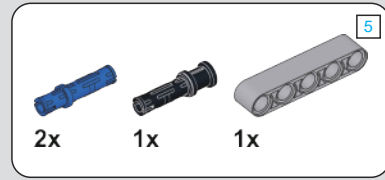

134

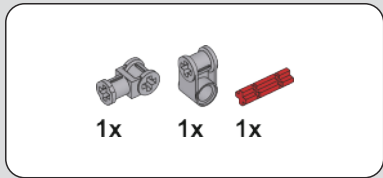
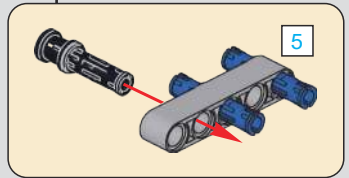
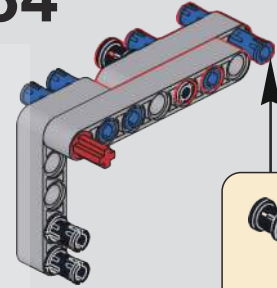
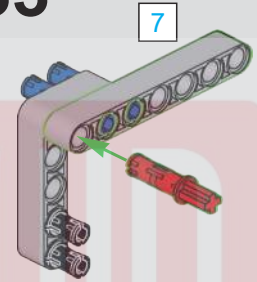
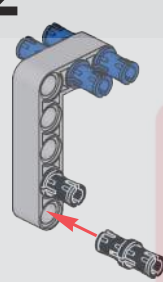

135



136

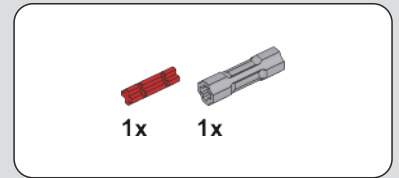

137

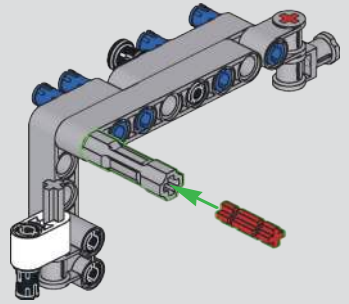
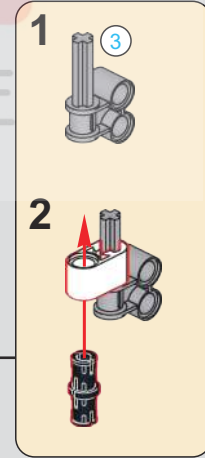
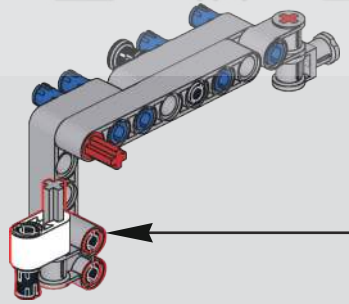
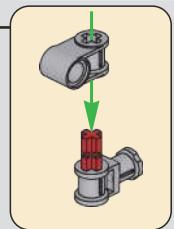
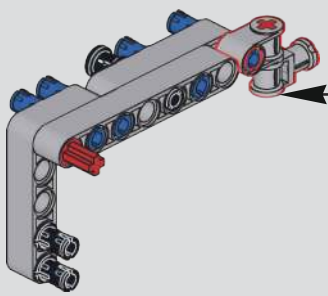

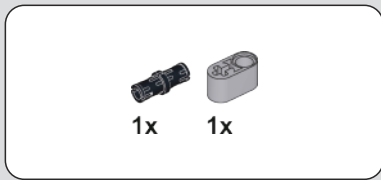

138

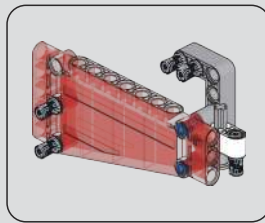
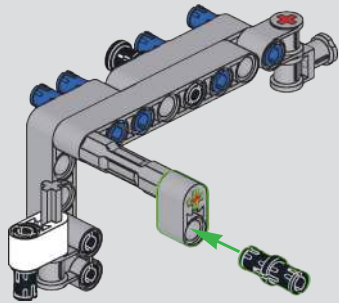

139

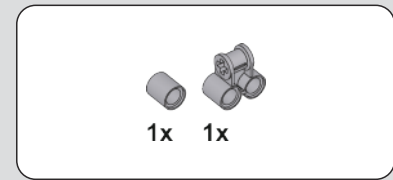
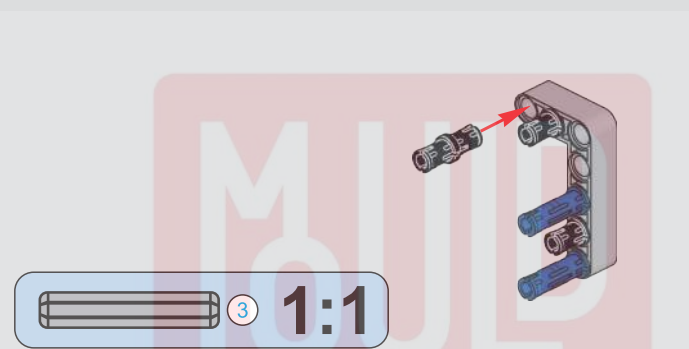
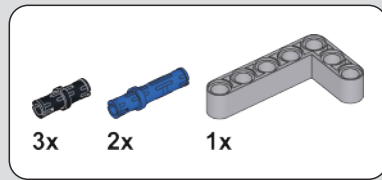

140

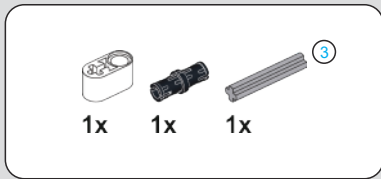
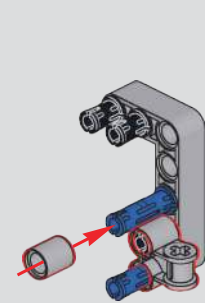

141

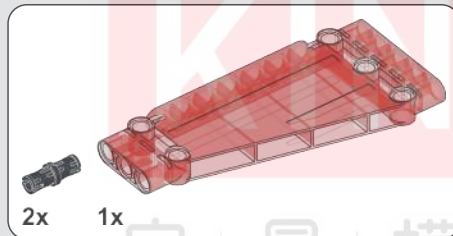
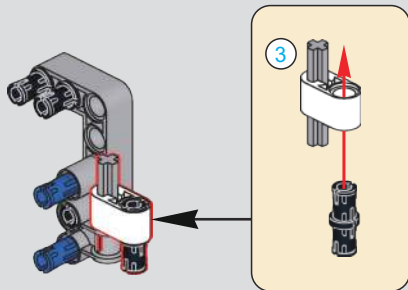

142

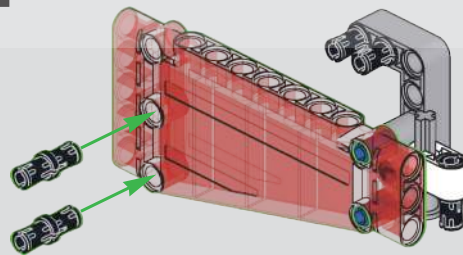

143

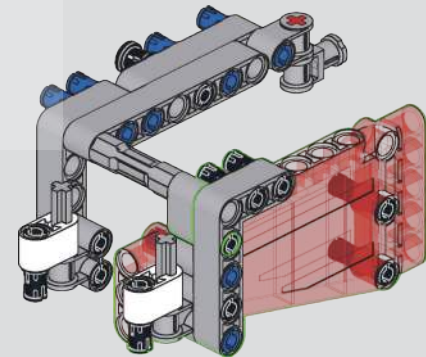

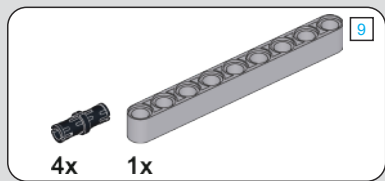

144

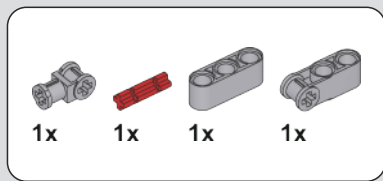
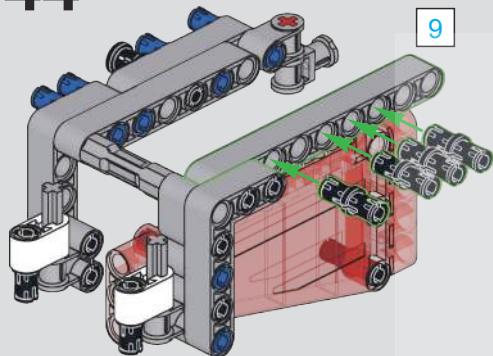

145

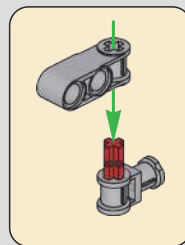
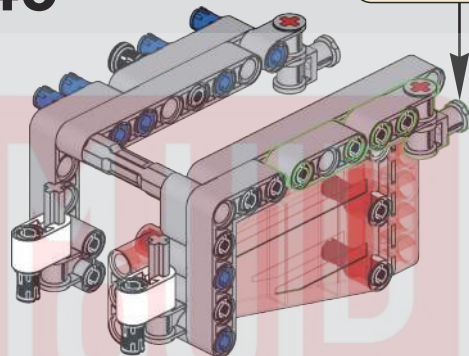

146

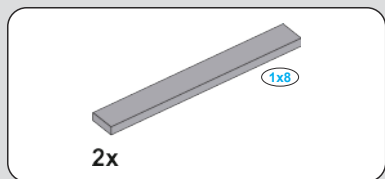
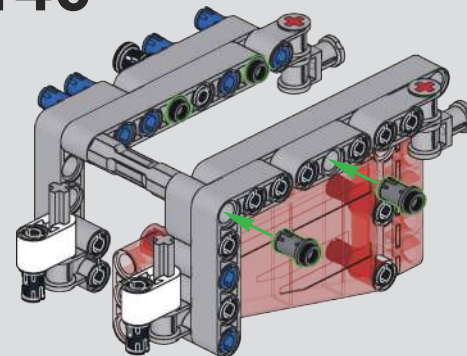

147

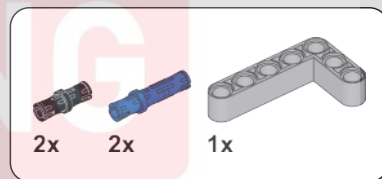
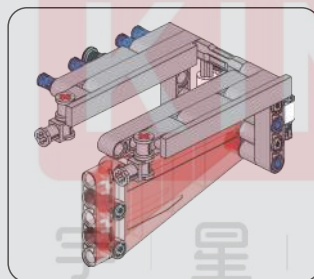
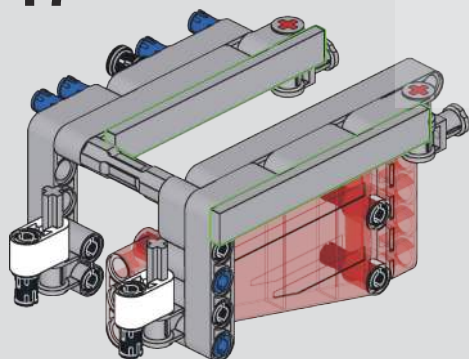

148

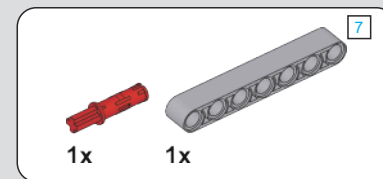
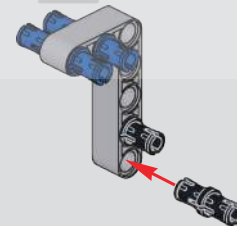

149

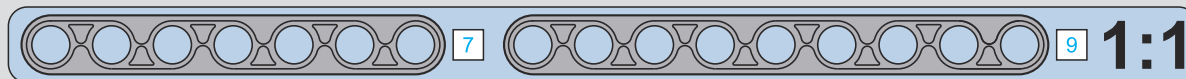
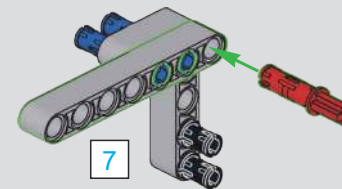

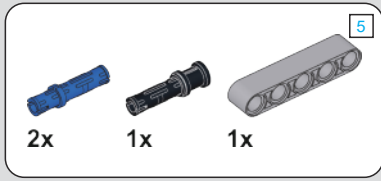

150

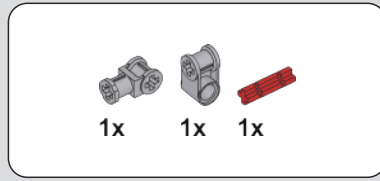
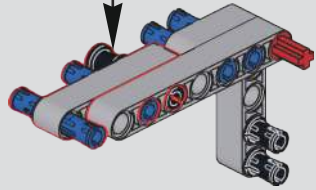
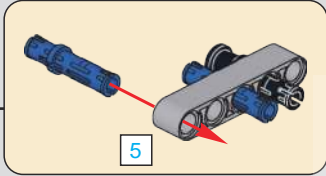

151

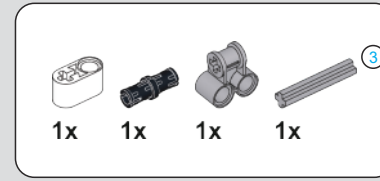
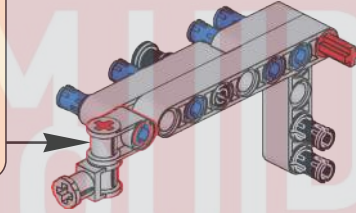
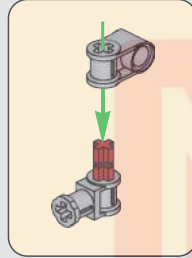

152

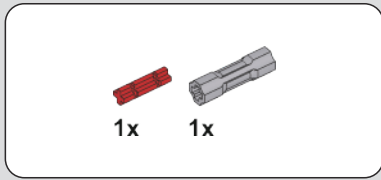
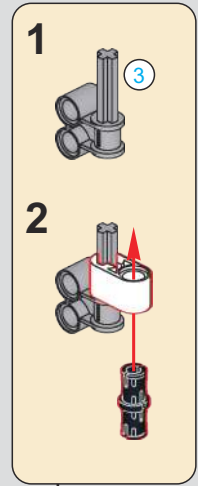
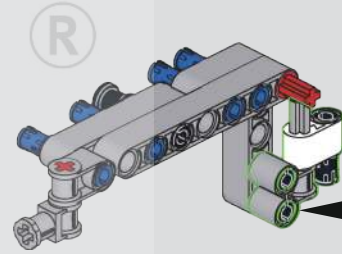

153

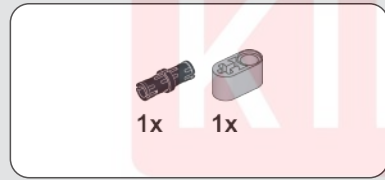
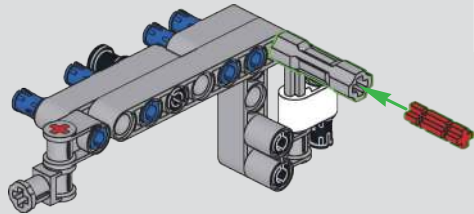

154

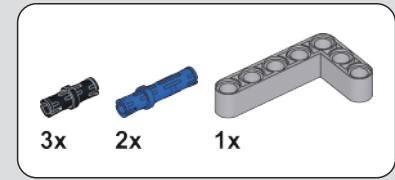
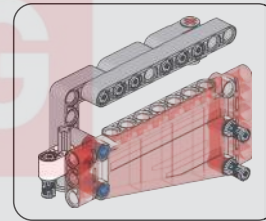
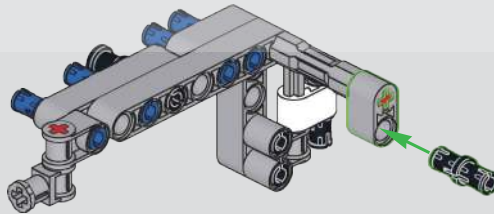

155

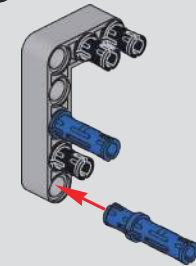

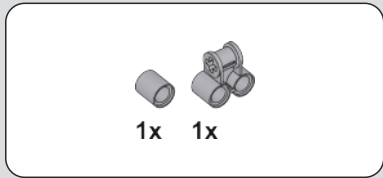

156

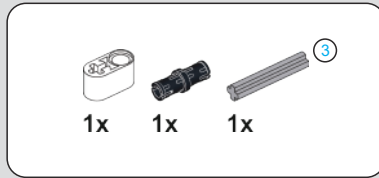
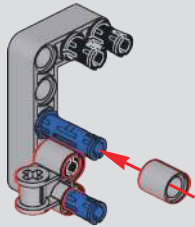

157

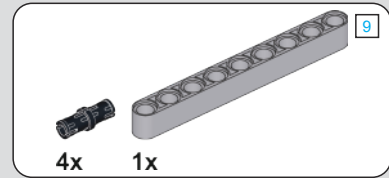
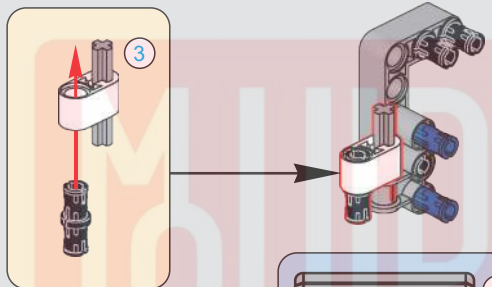

158

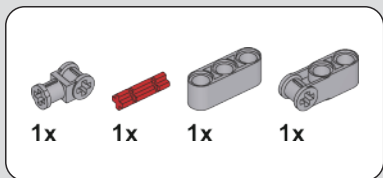
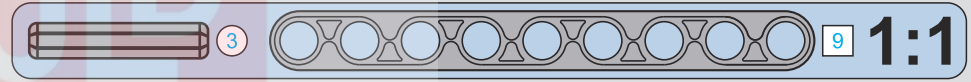
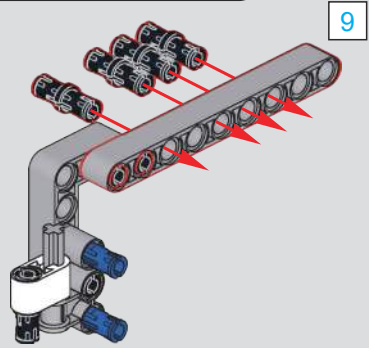

159

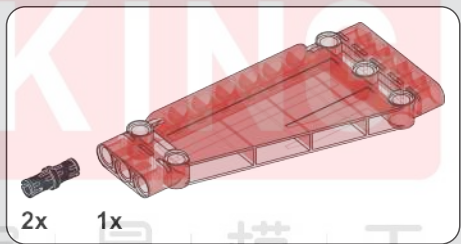
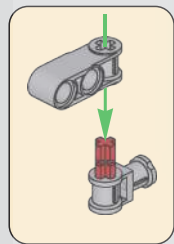
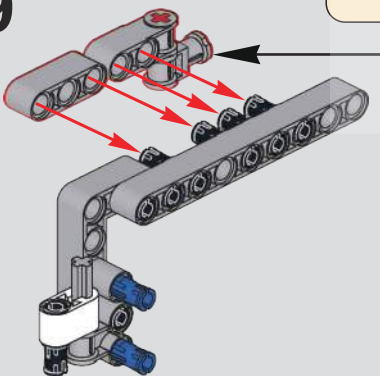

160

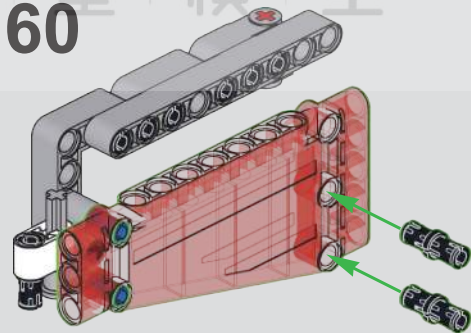

161

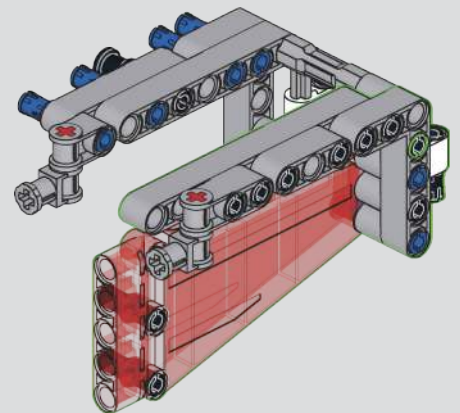



162

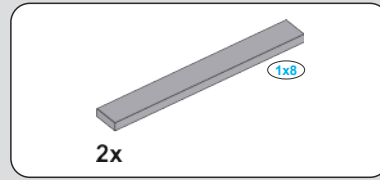
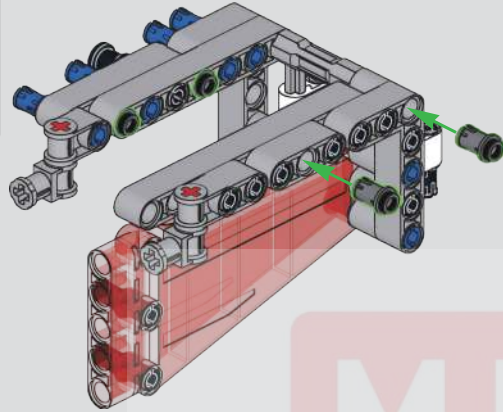

163

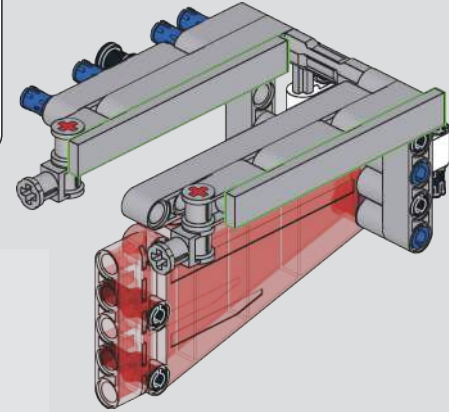

164

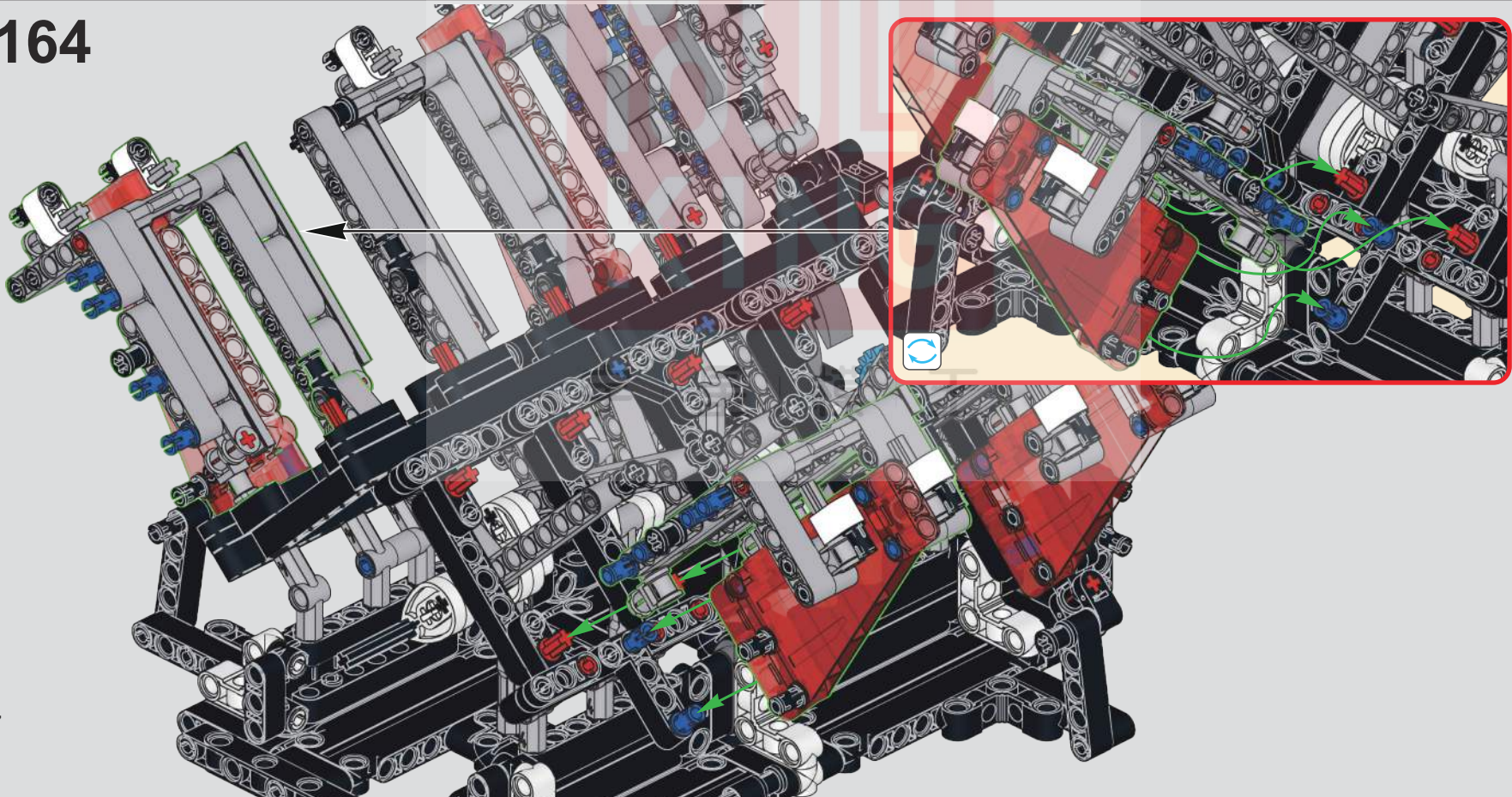

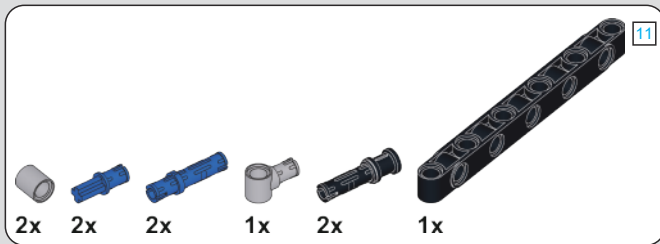

166

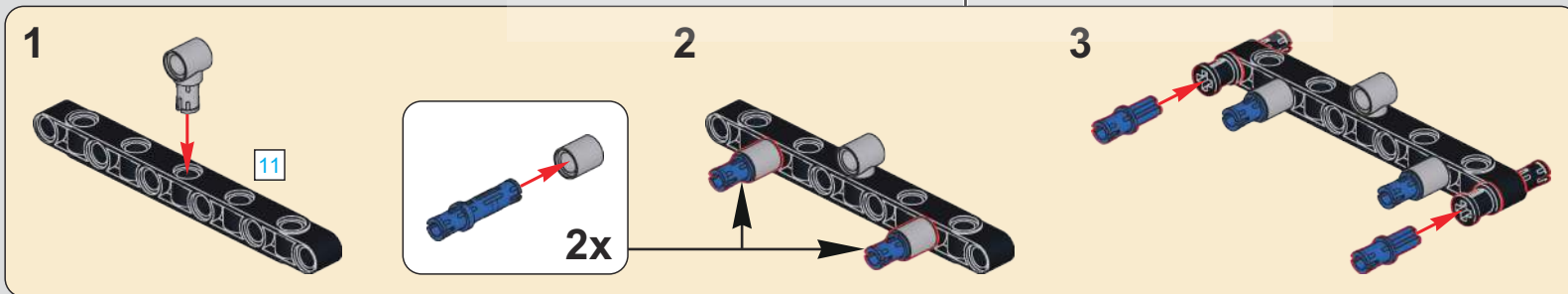
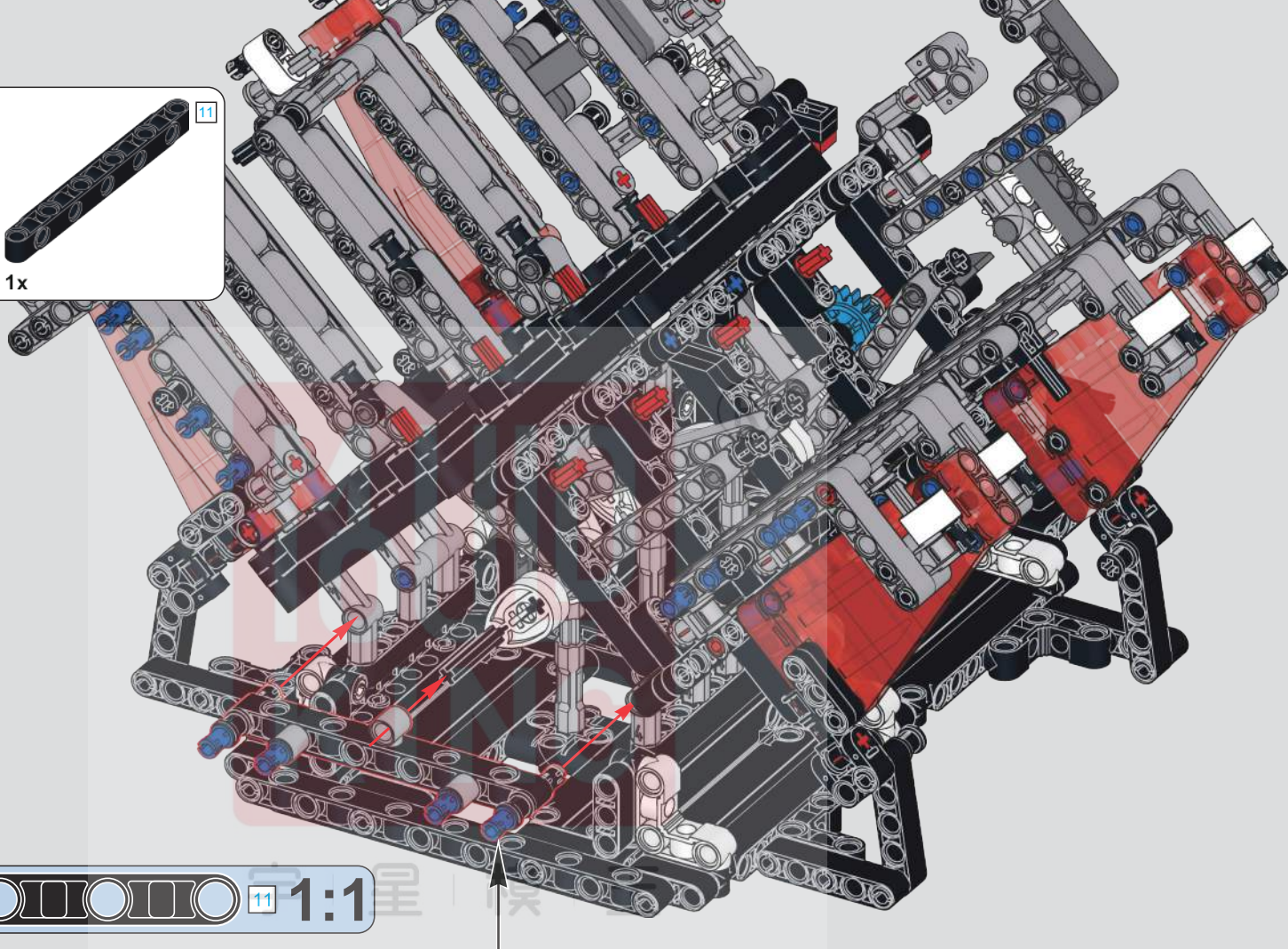

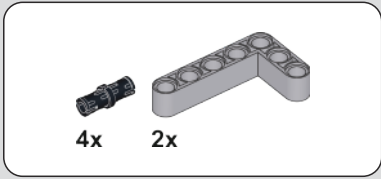

167

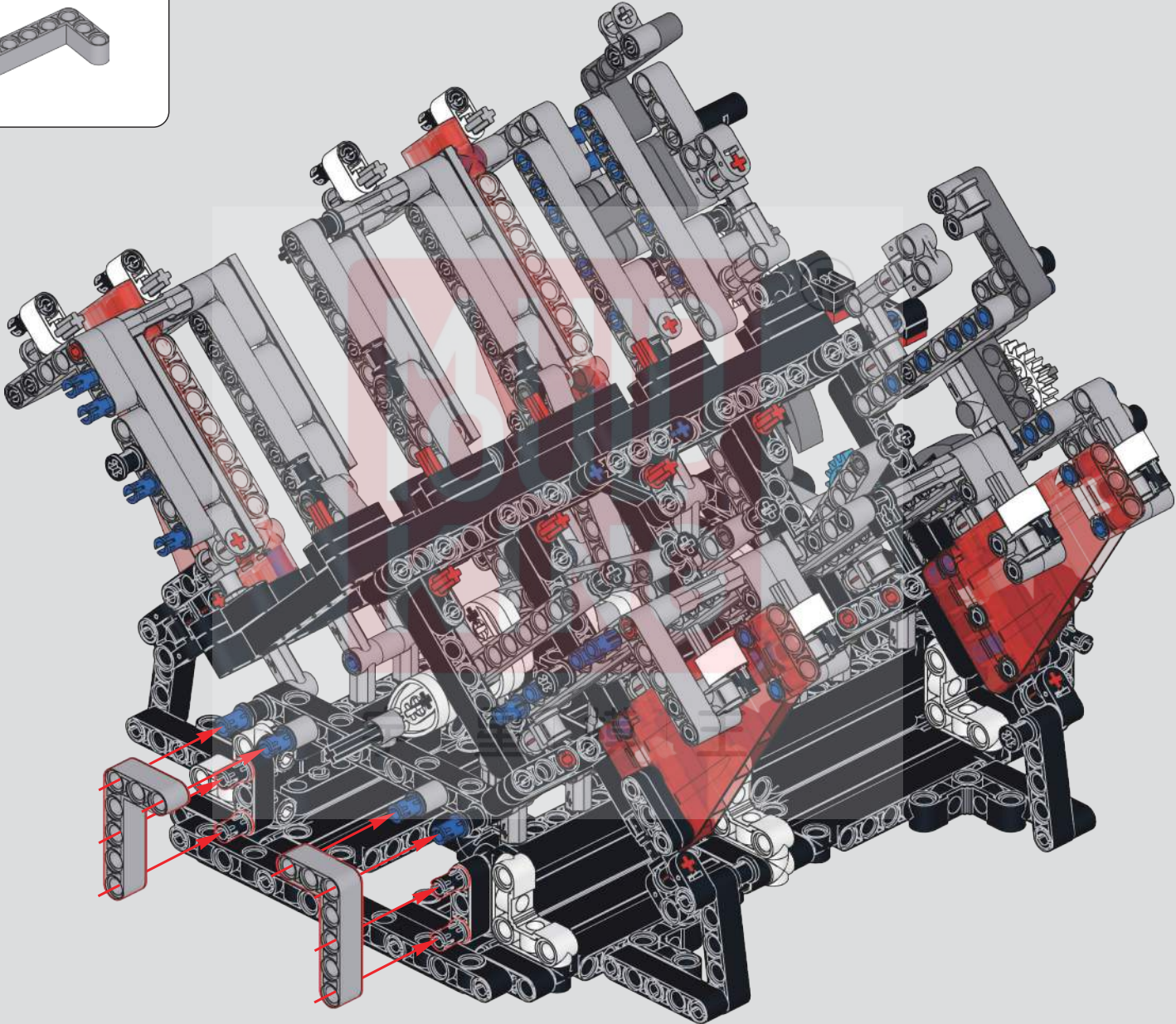

■ (Carbon fibre accessories)
 (碳纤维配件)

8x 8x 8x 8x 8x

* (Plating) (电镀配件)

④ 1:1

168

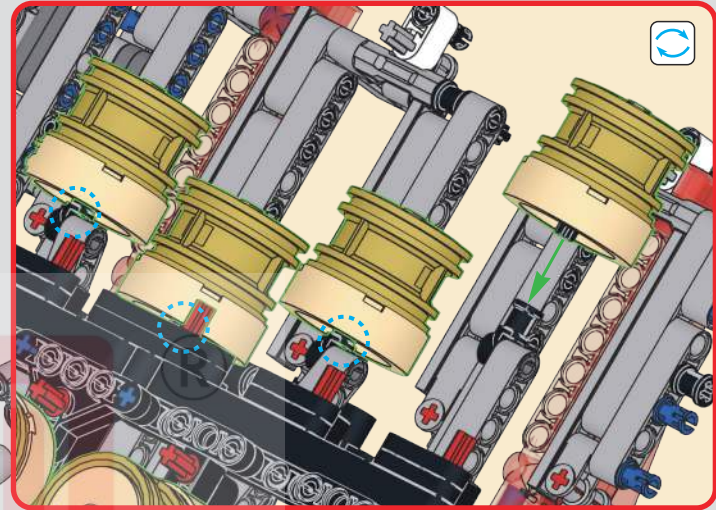
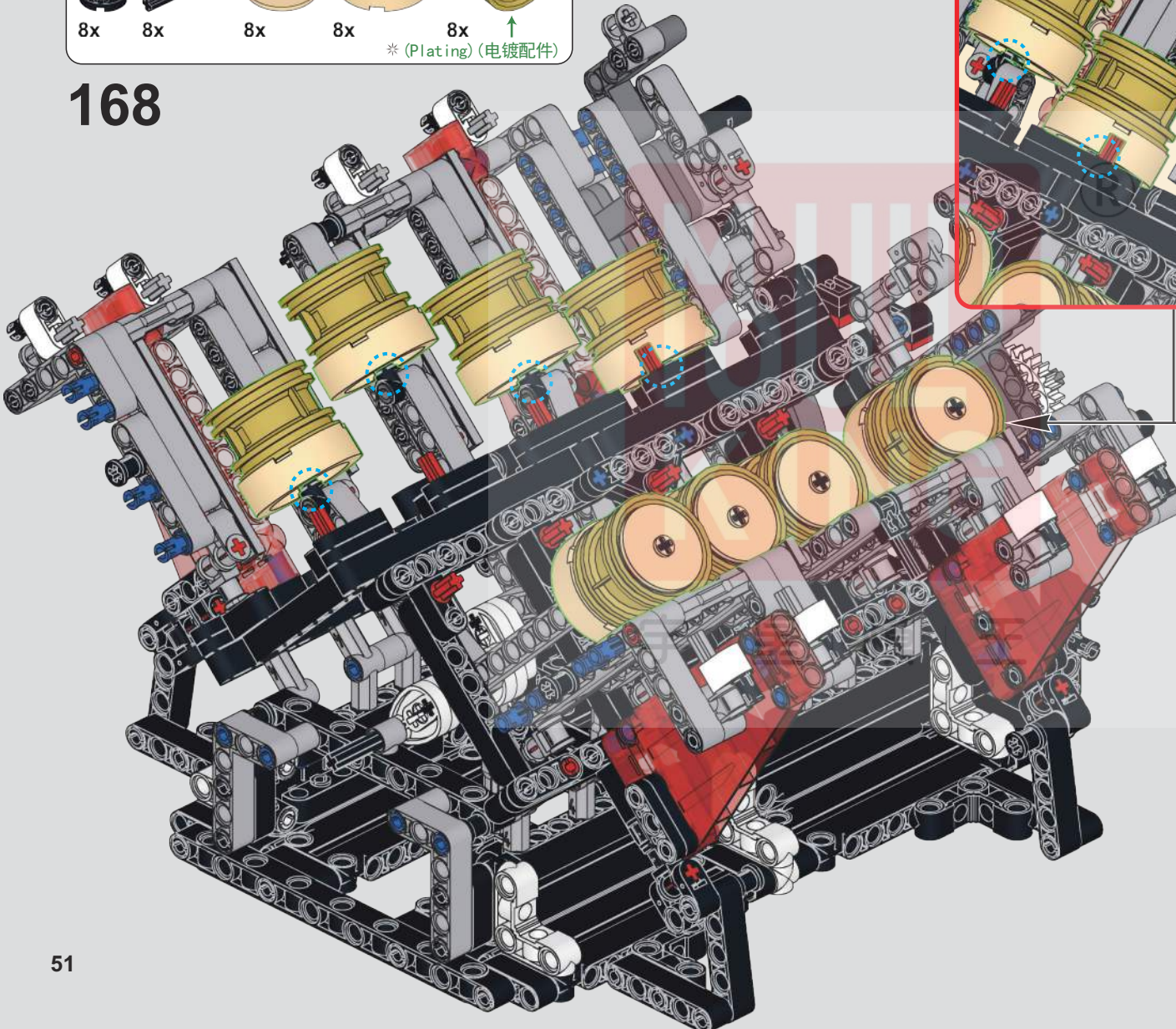

- 1 ④
- 2
- 3 ④

8x

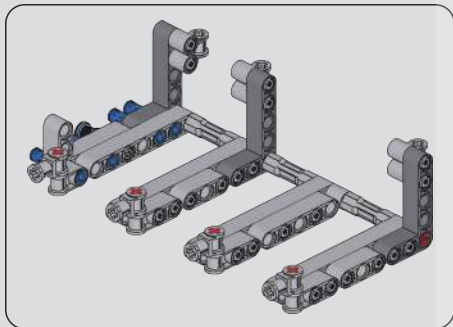
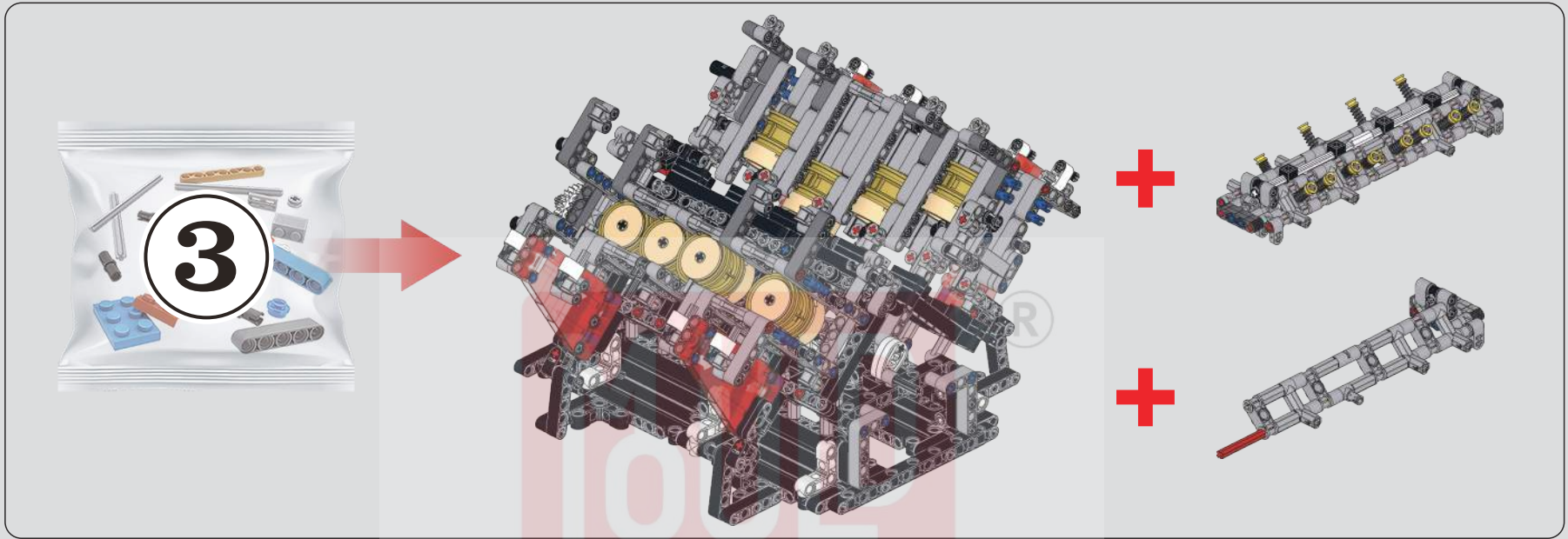

169

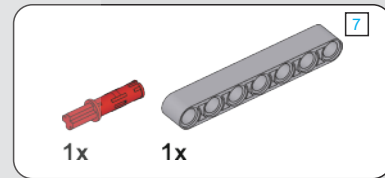

170

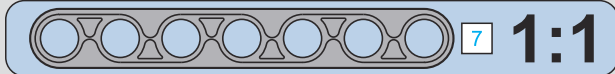
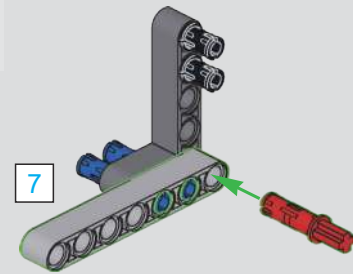
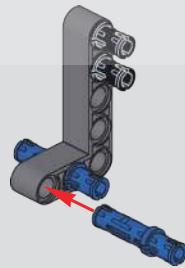

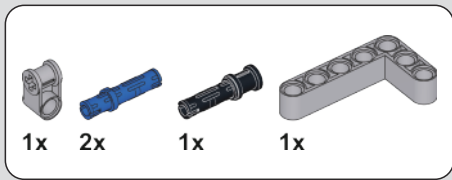

171

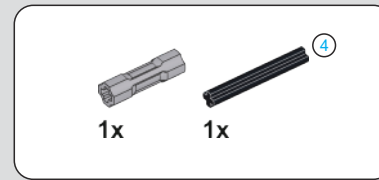
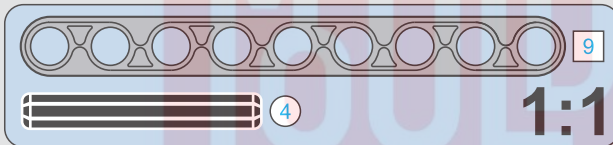
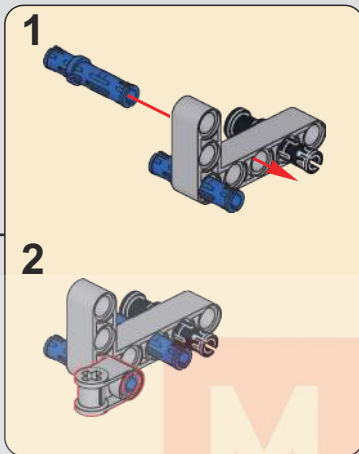
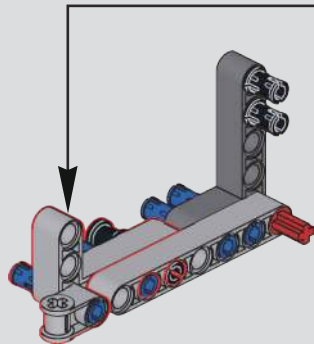

172

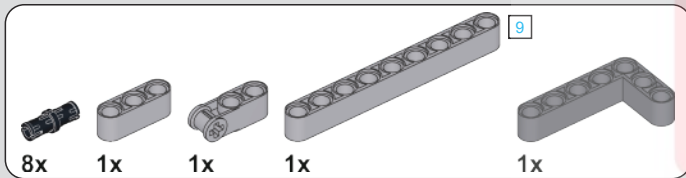
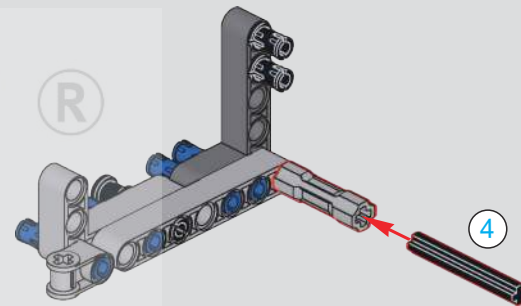

173

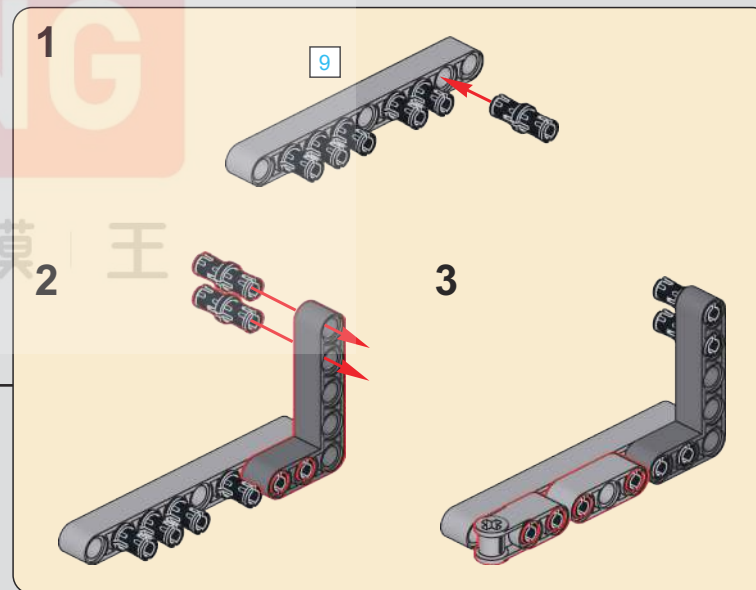
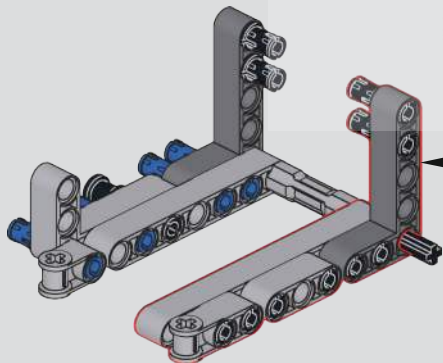

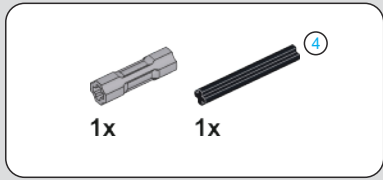

174

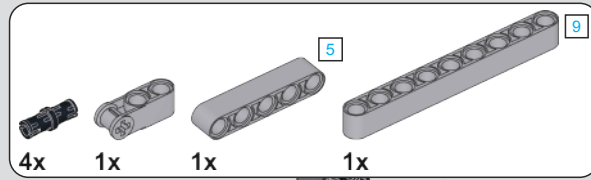
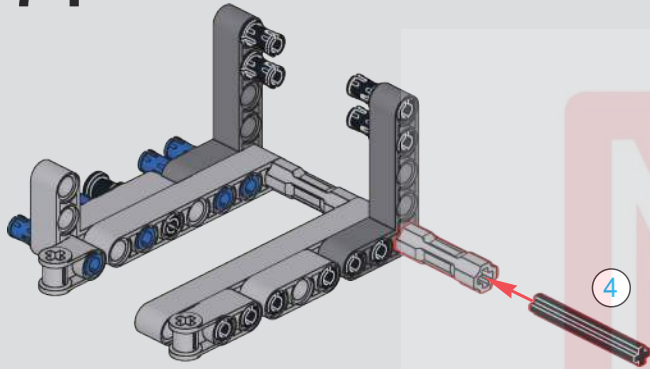

175

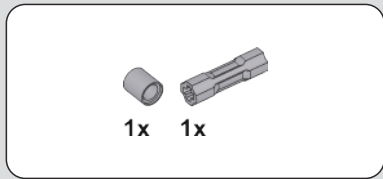
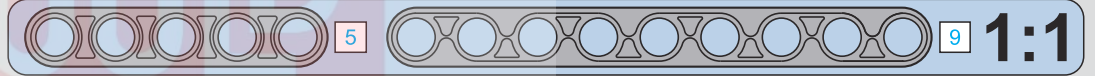
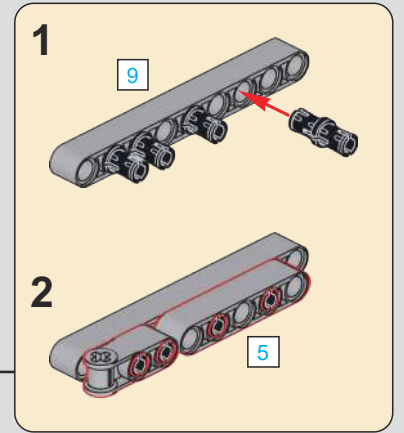
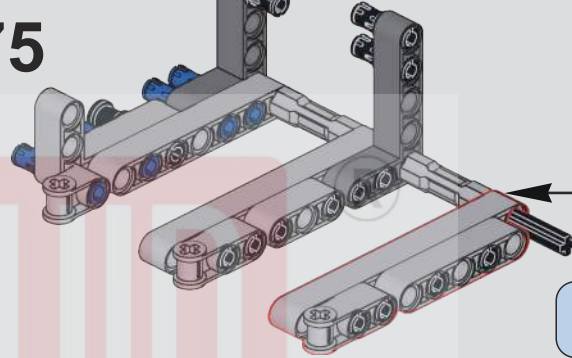

176

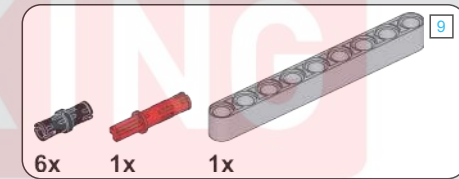
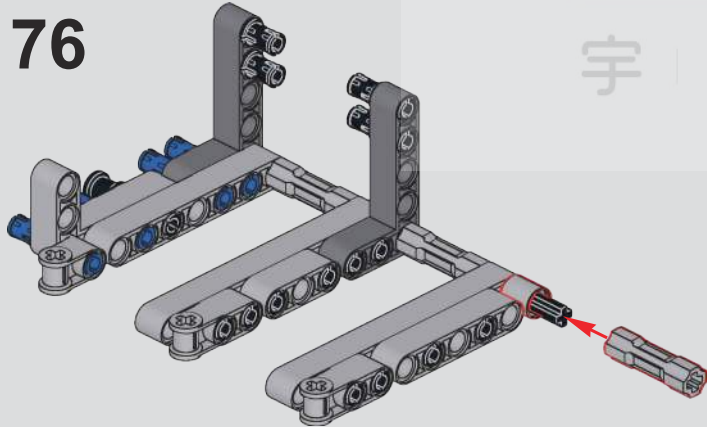

177

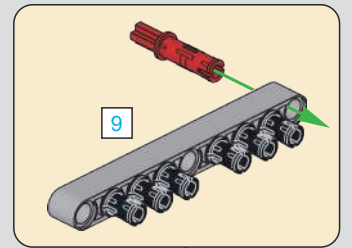
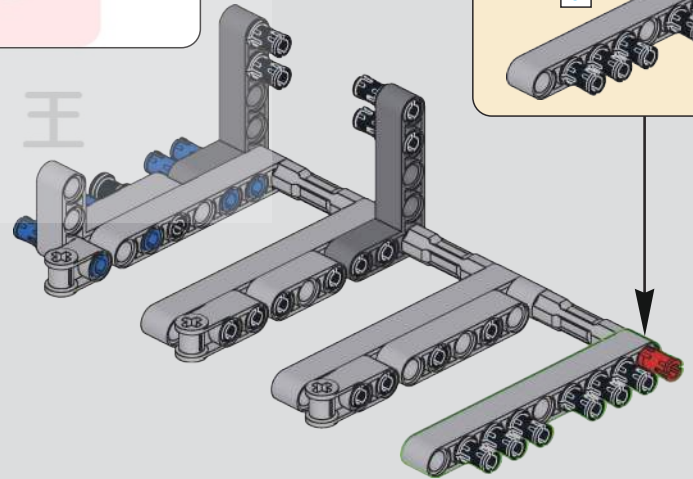

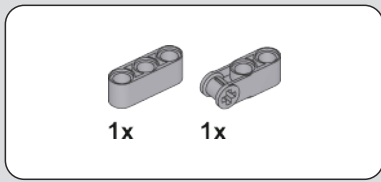

178

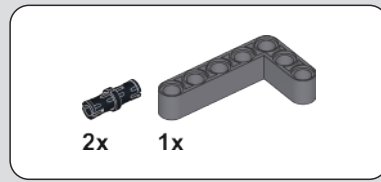
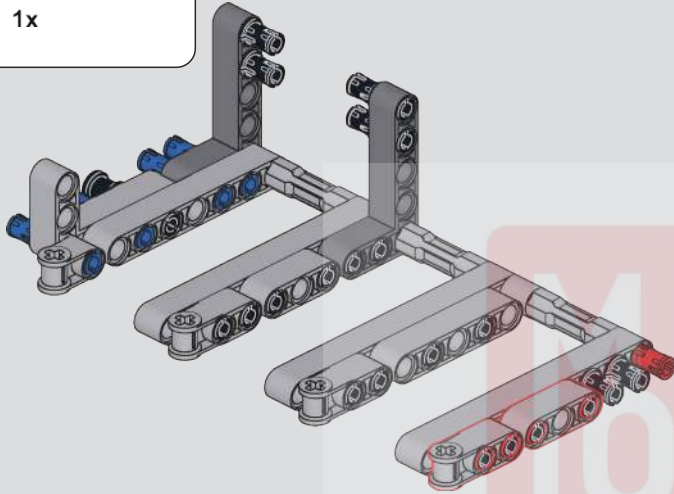

179

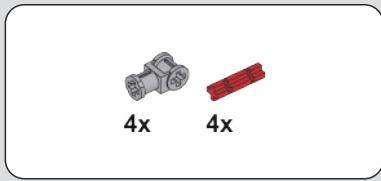
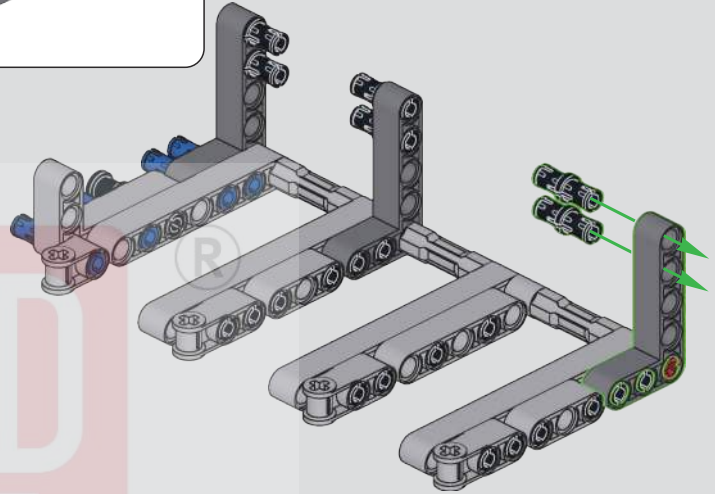

180

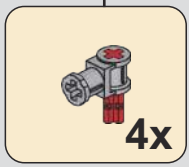
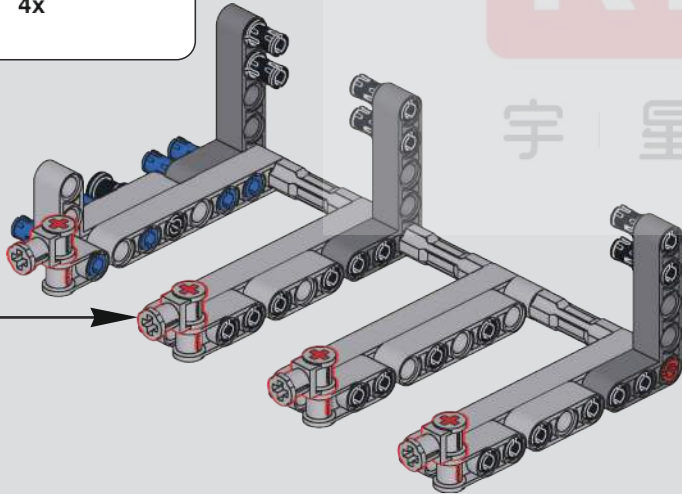

181

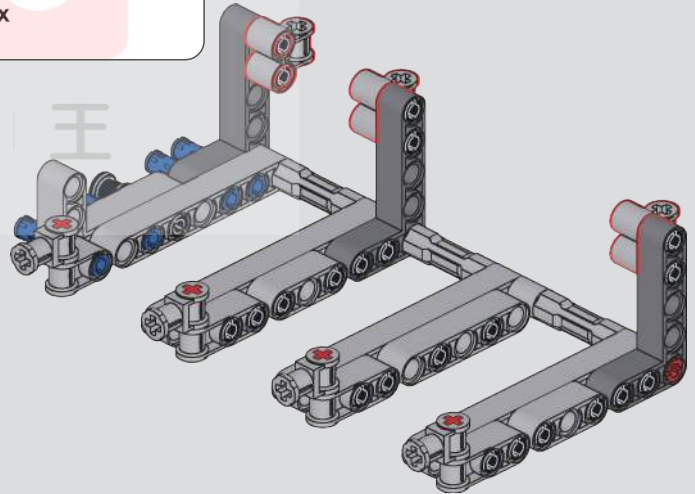

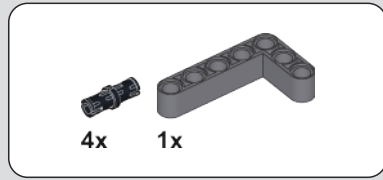
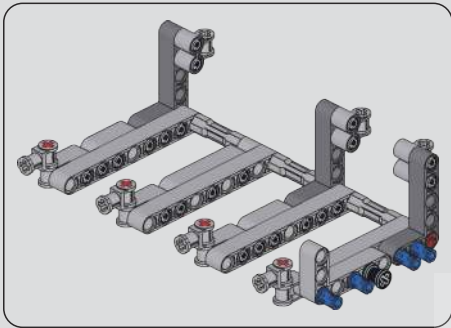

182

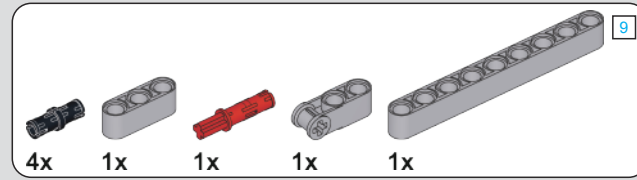

183

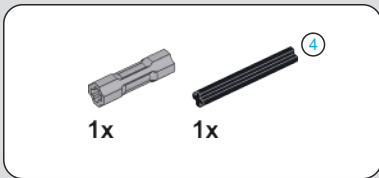
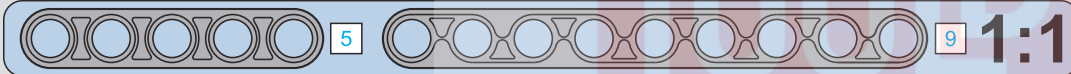
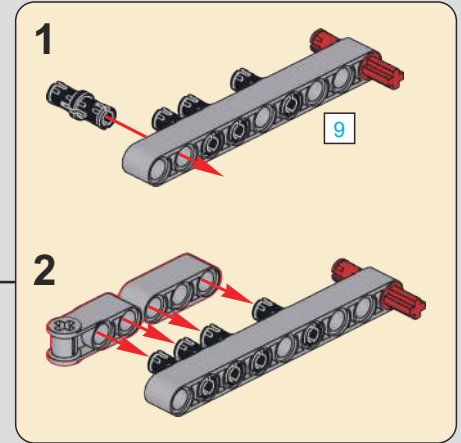
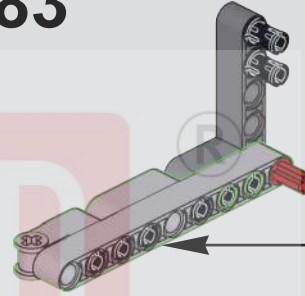
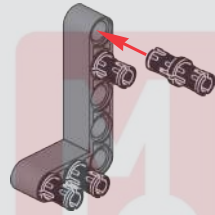

184

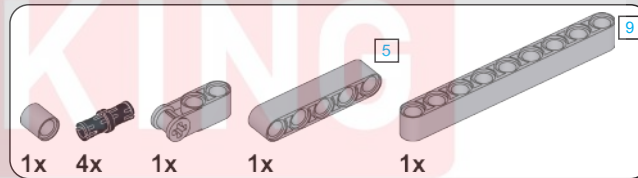
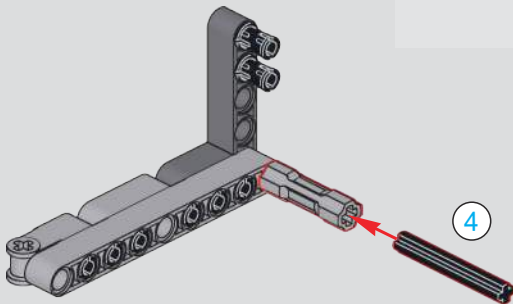

185

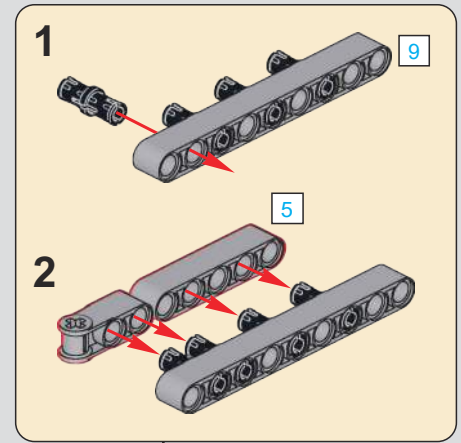
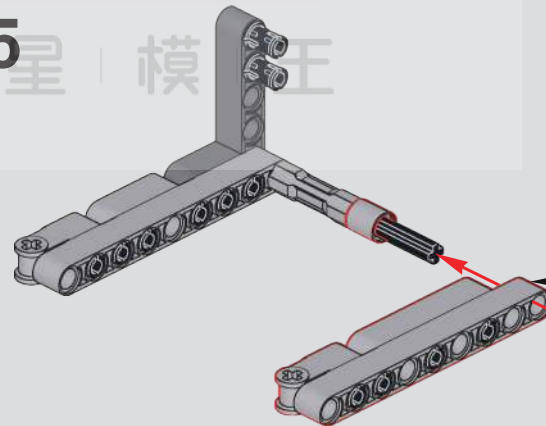

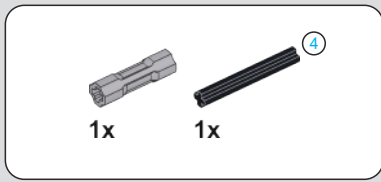

186

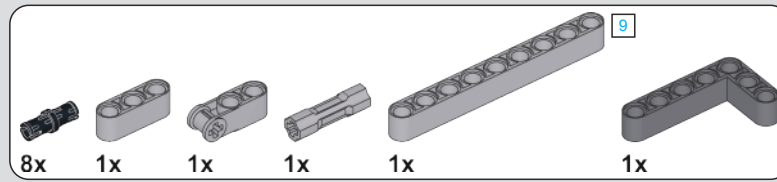
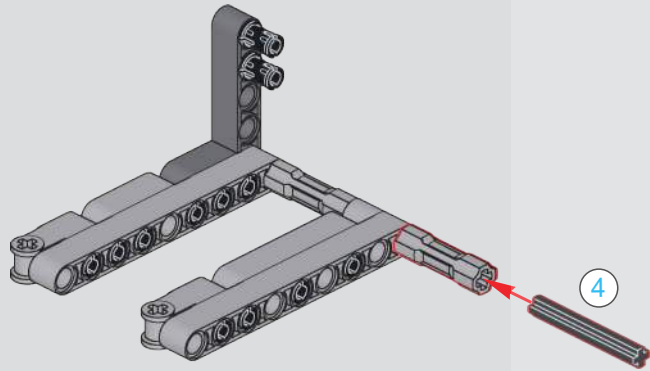

187

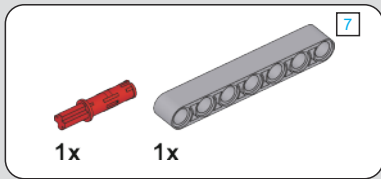
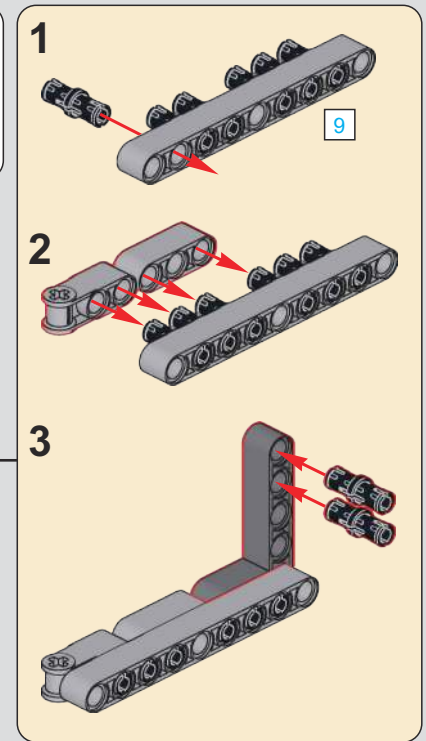
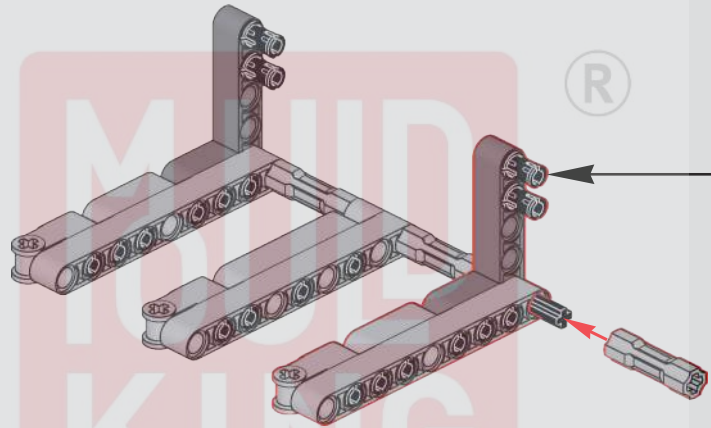

188

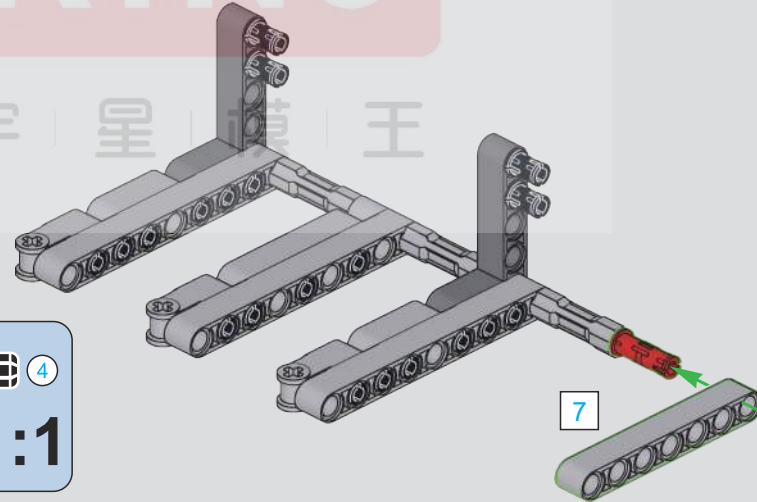
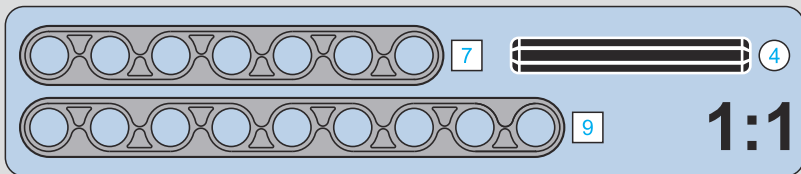

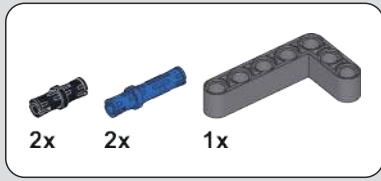

189

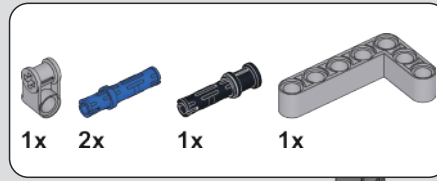
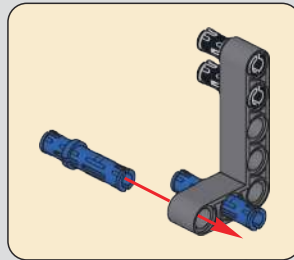
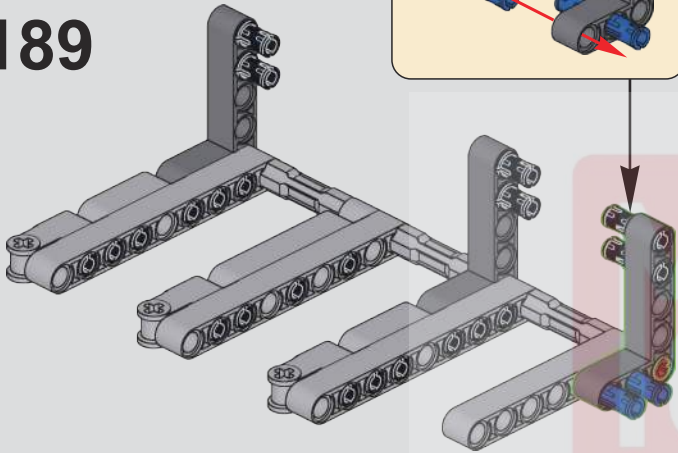

190

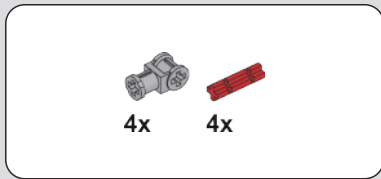
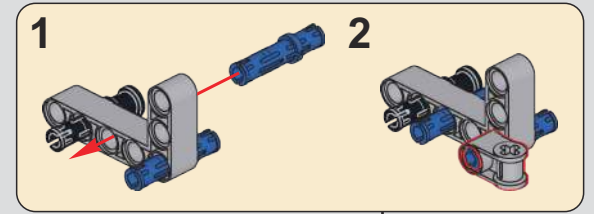
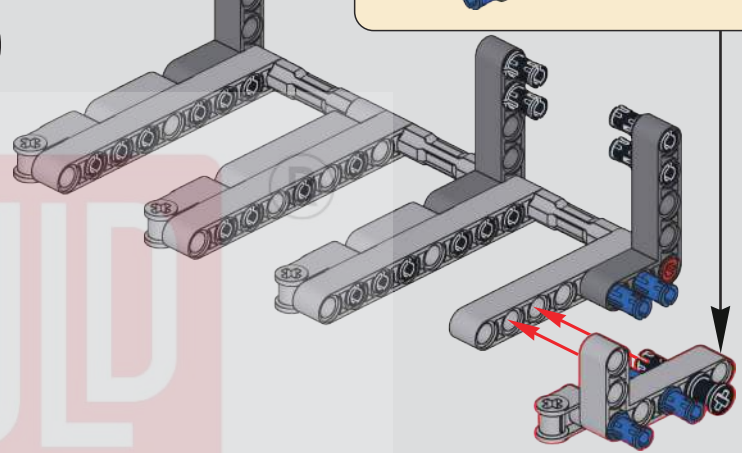

191

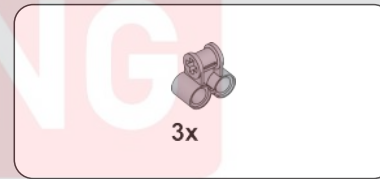
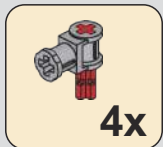
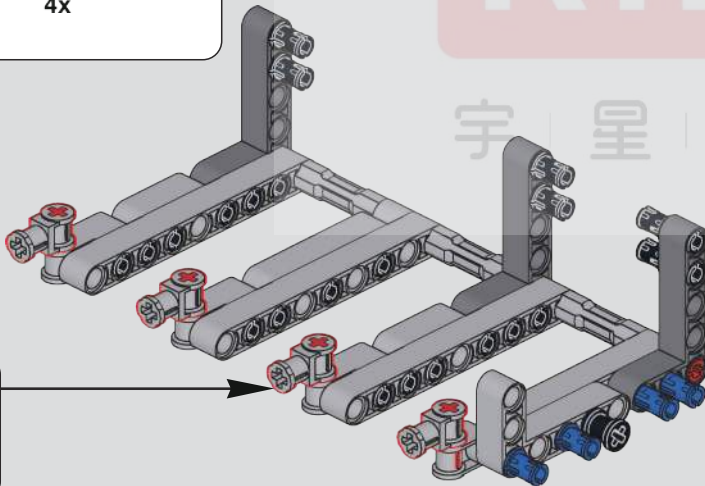

192

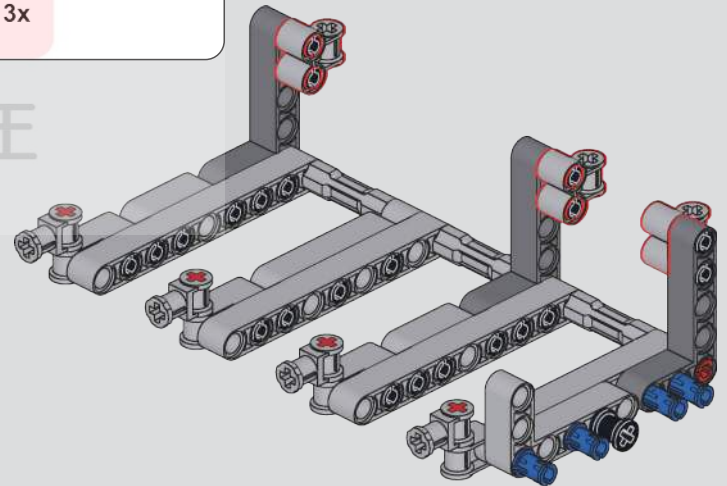

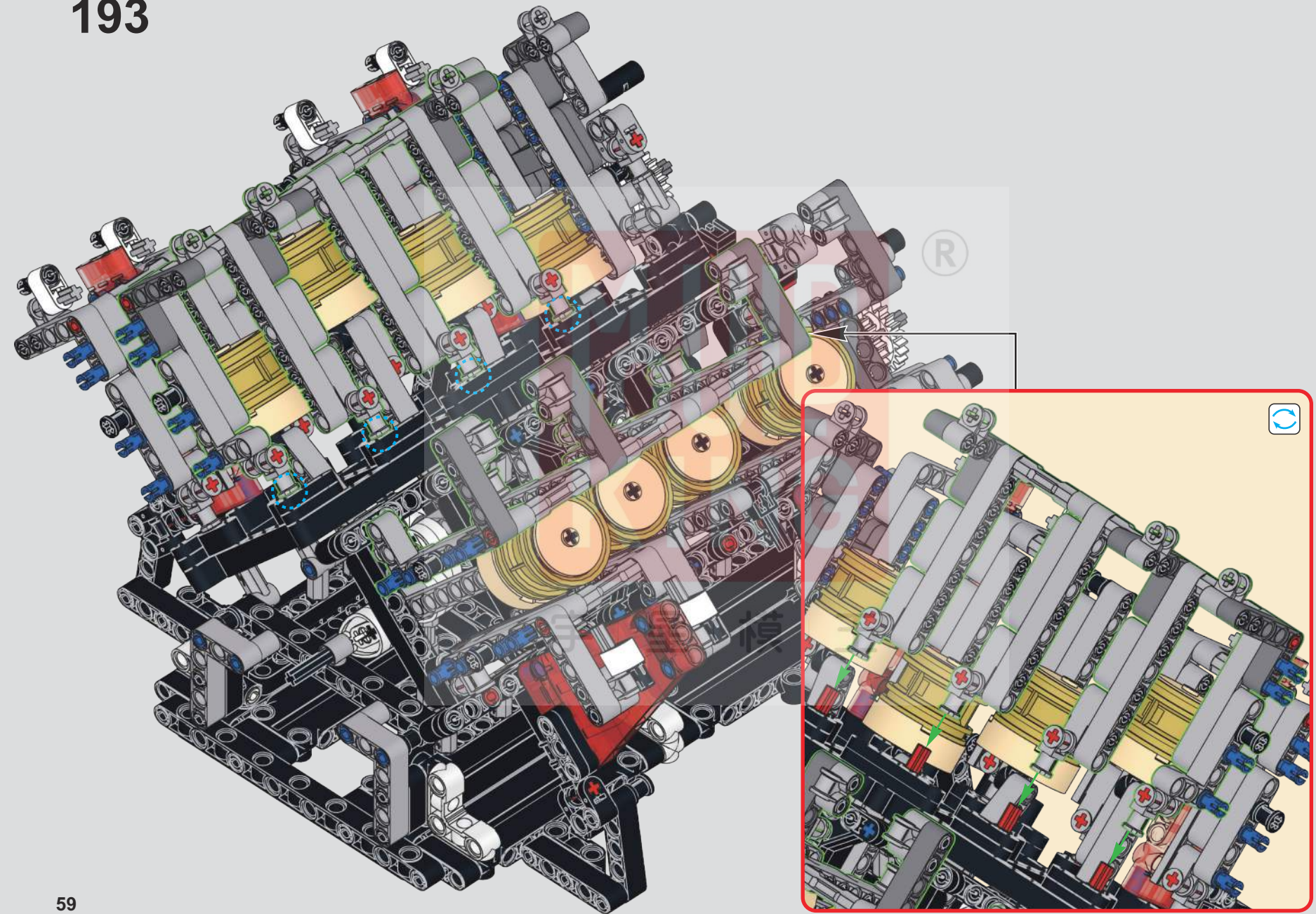

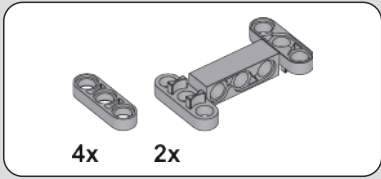

194

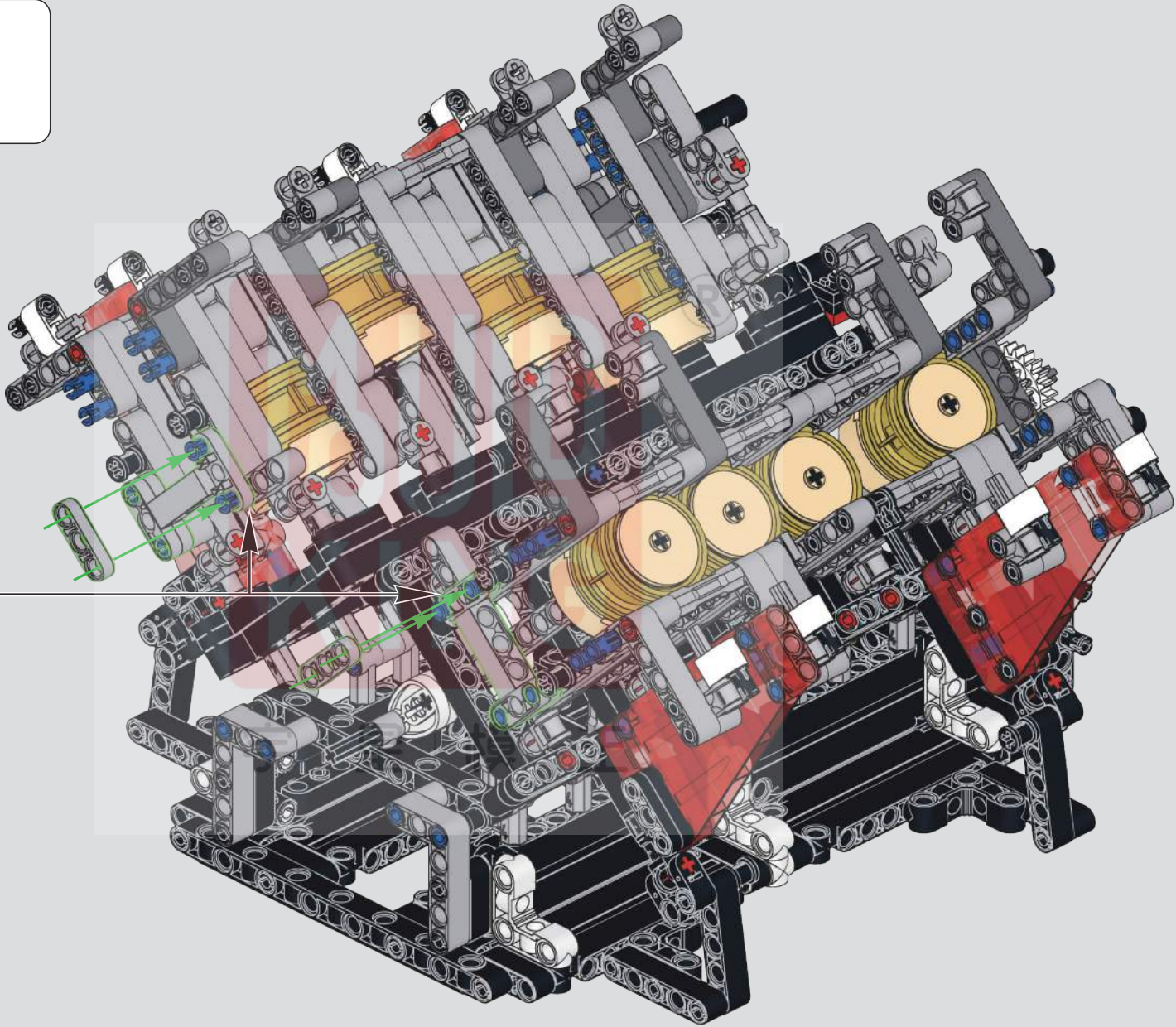
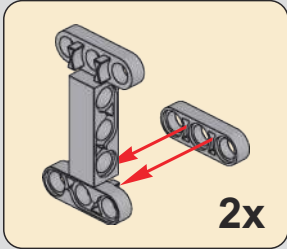

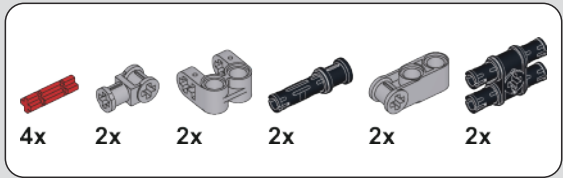

195

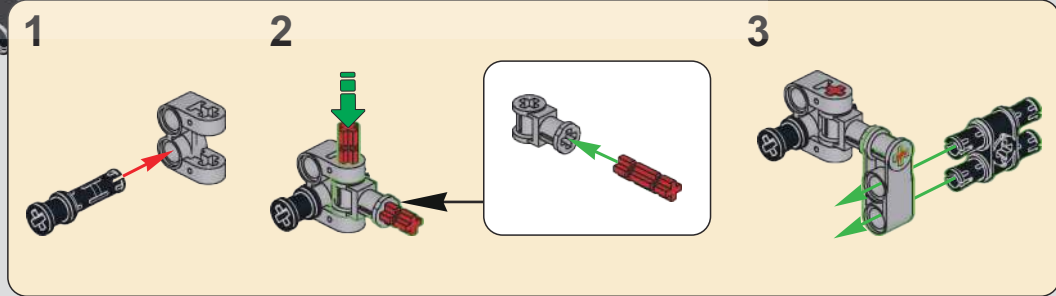
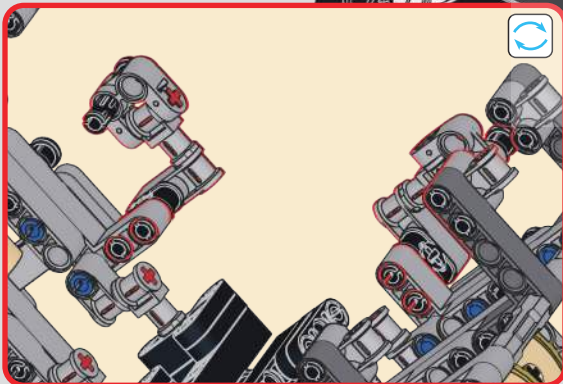
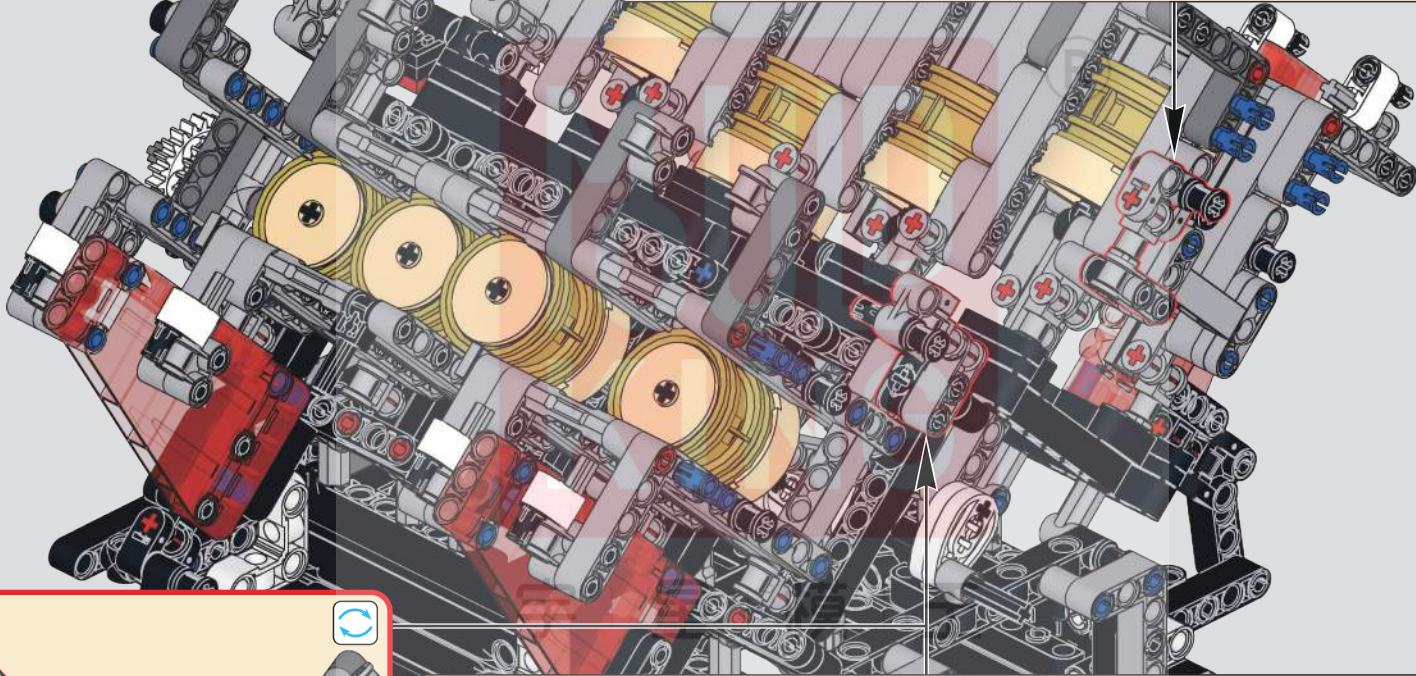
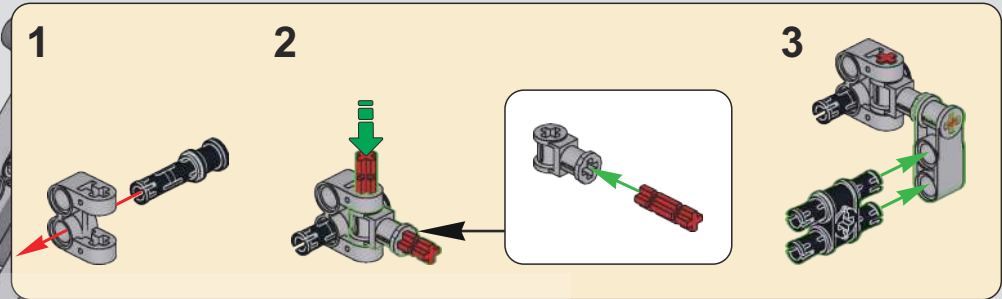

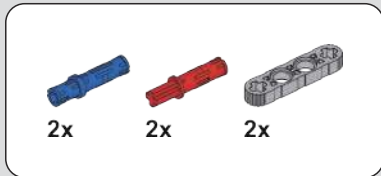
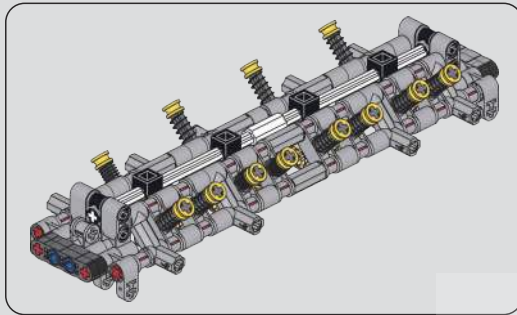

196

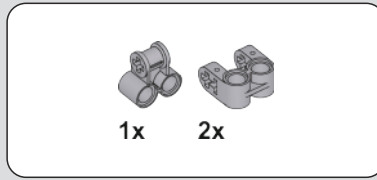

197

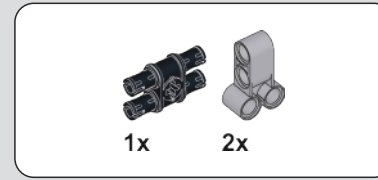

198

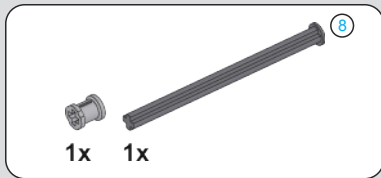
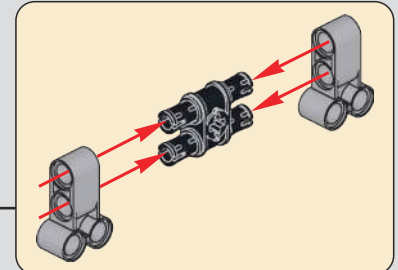
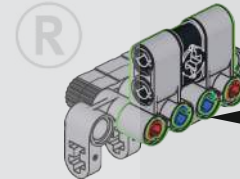
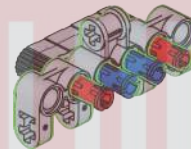
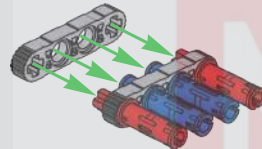
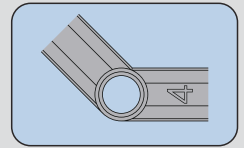

199

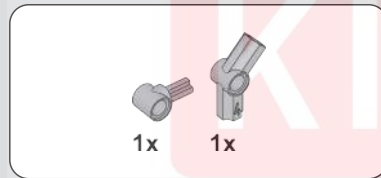

200

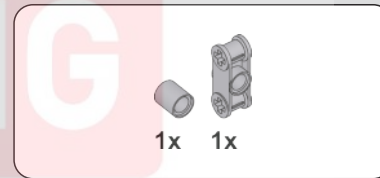

201

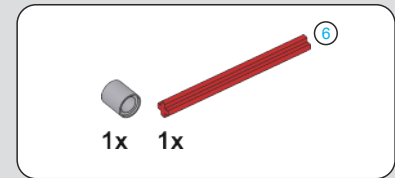

202

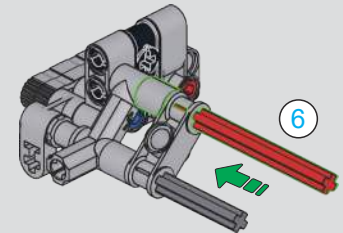
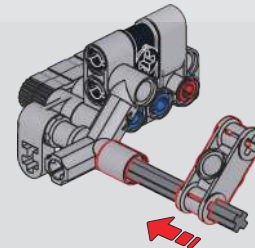
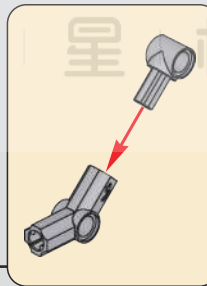
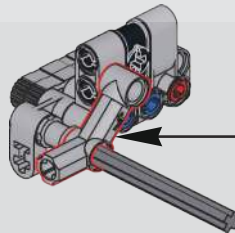
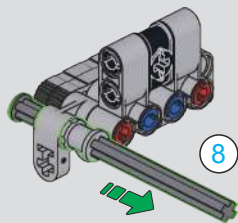

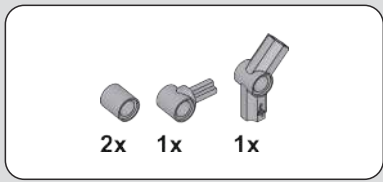

203

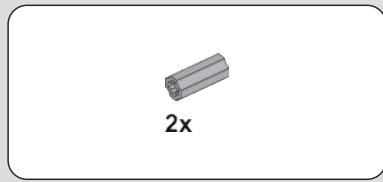
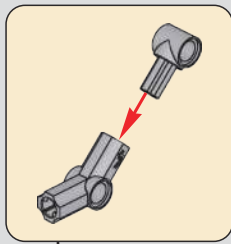
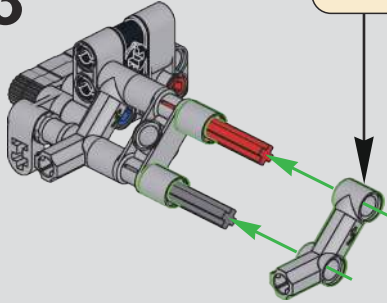

204

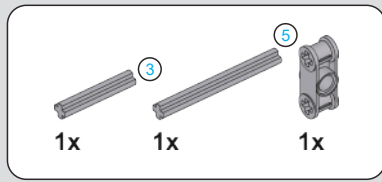
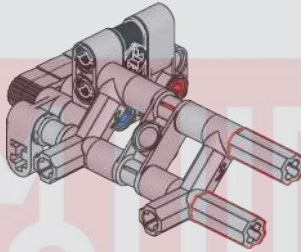

205

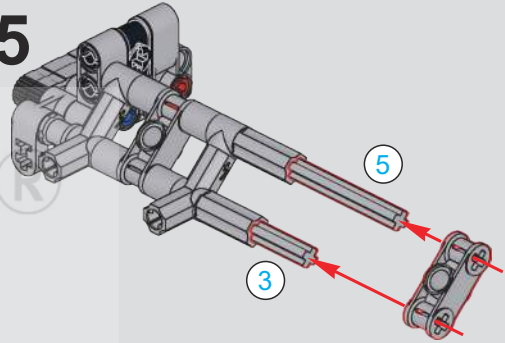

206

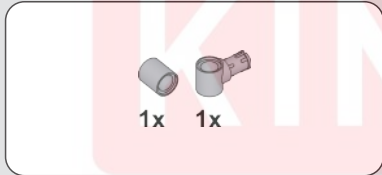
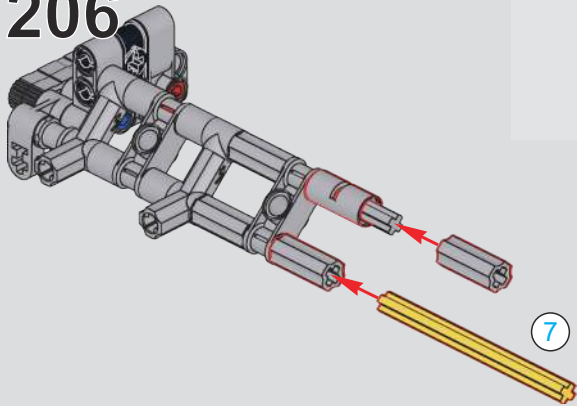
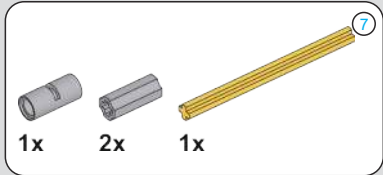

207

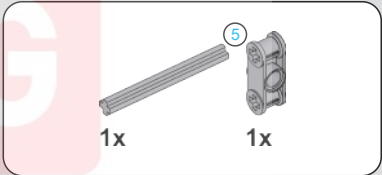
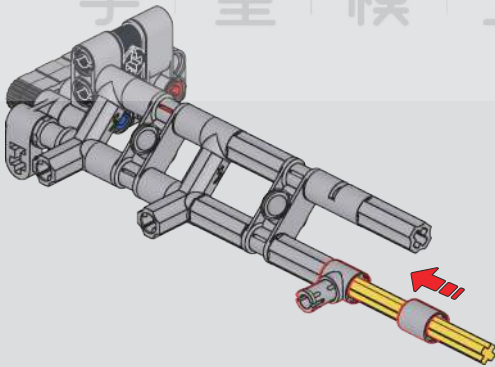

208

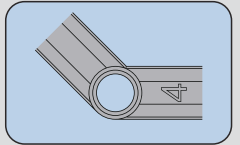
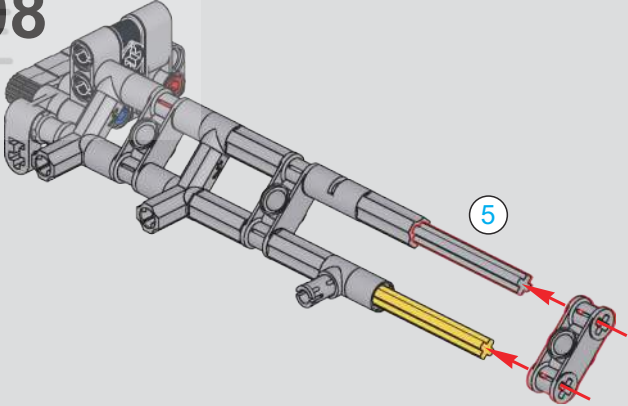

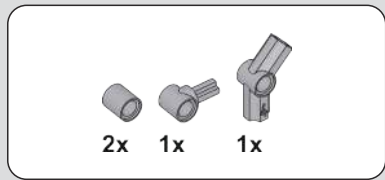

209

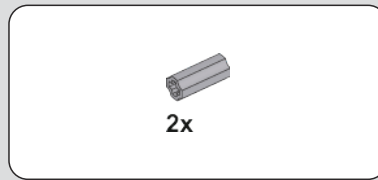
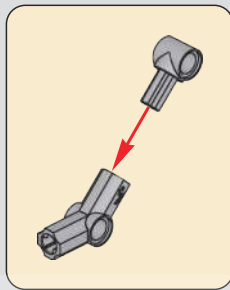
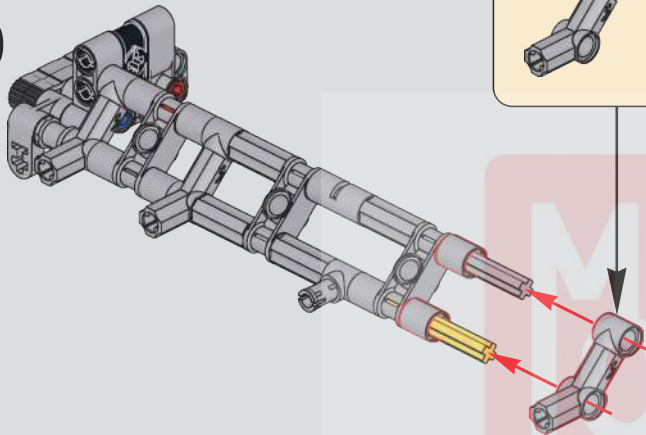

210

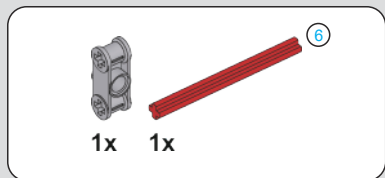
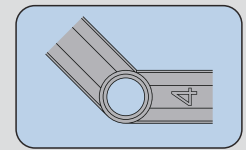
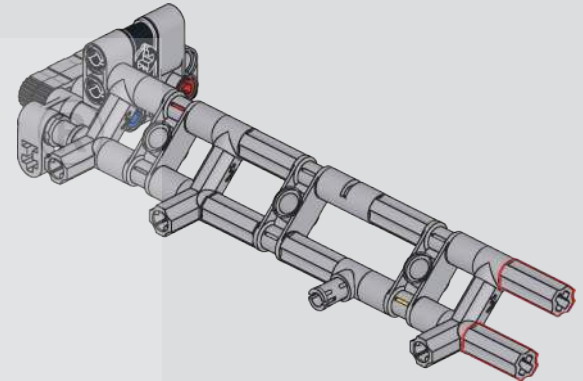

211

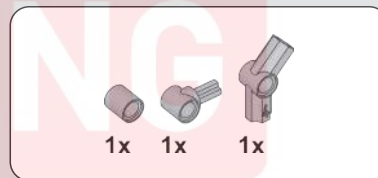
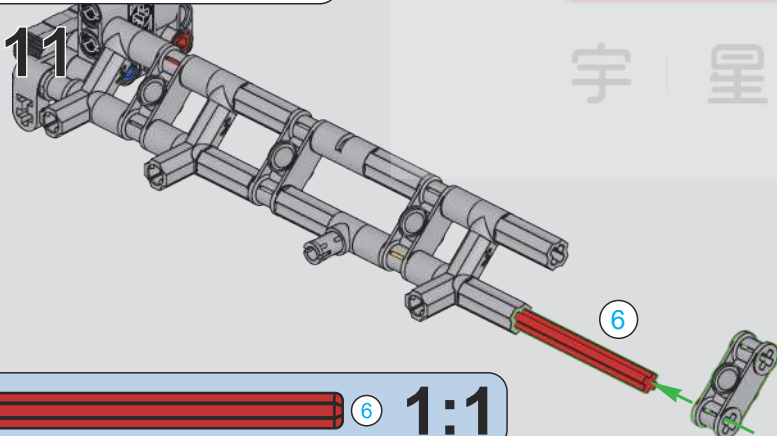

212

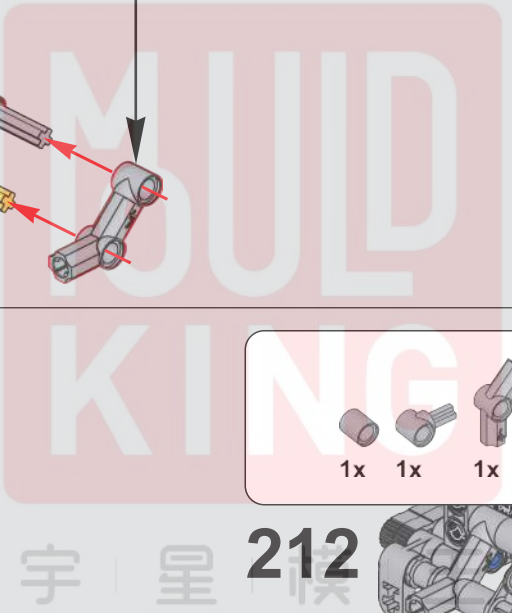
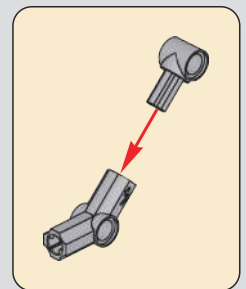
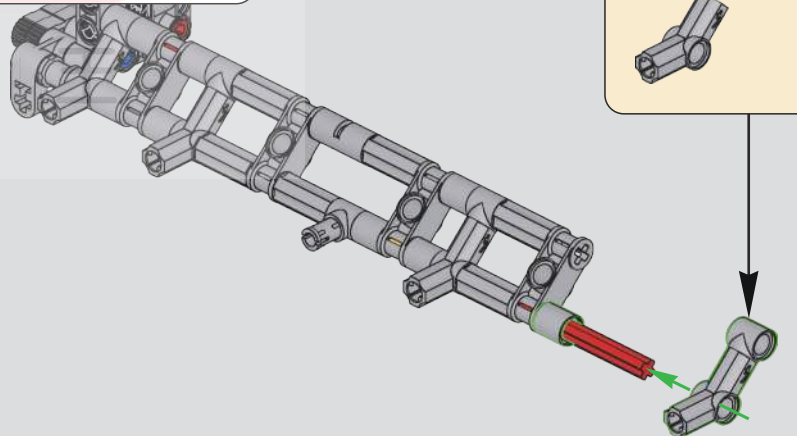

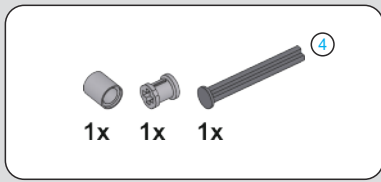

213

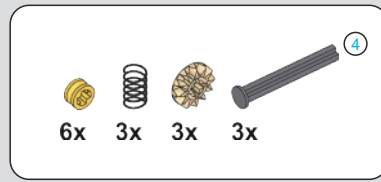
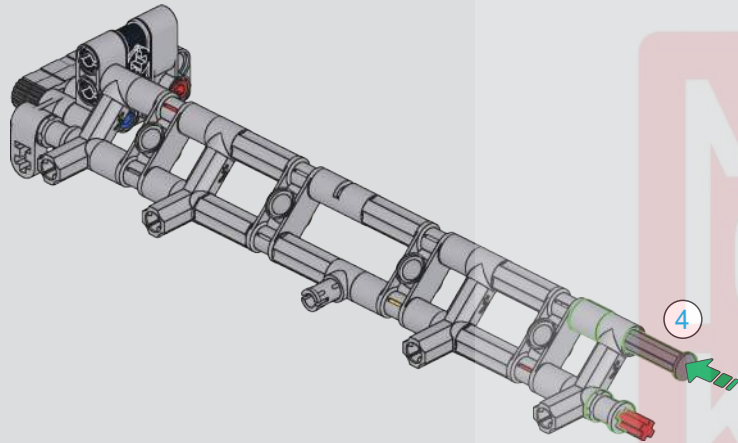

214

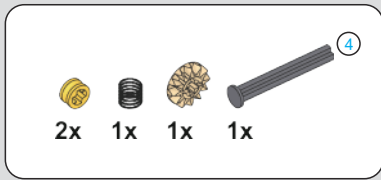
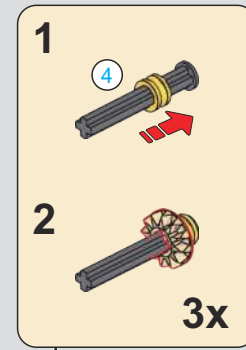
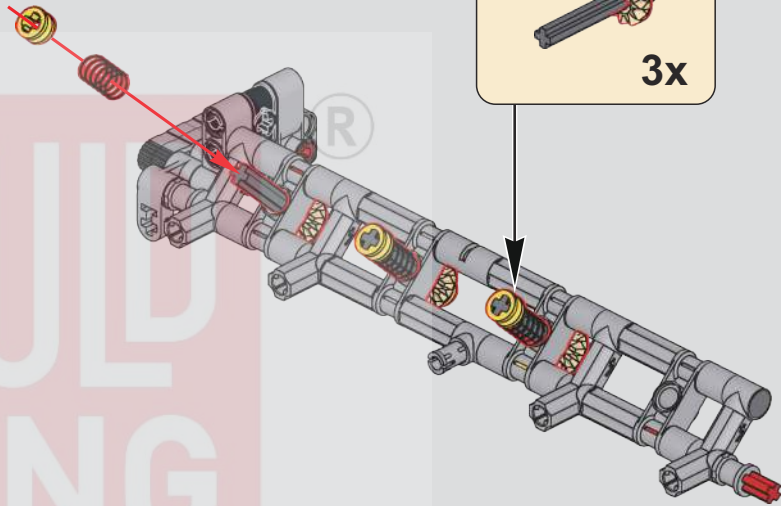

215

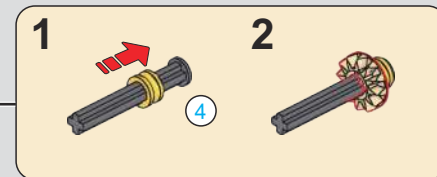
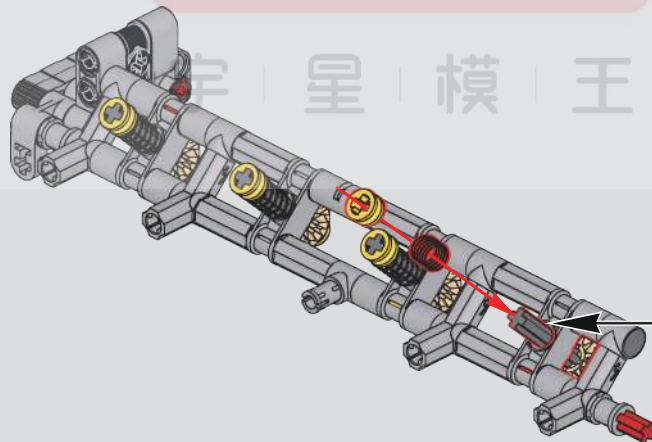

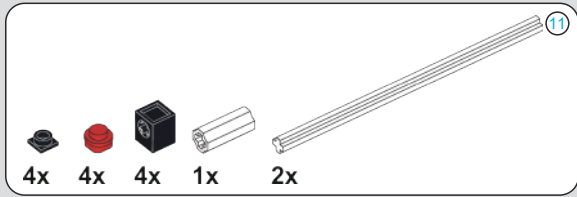

216

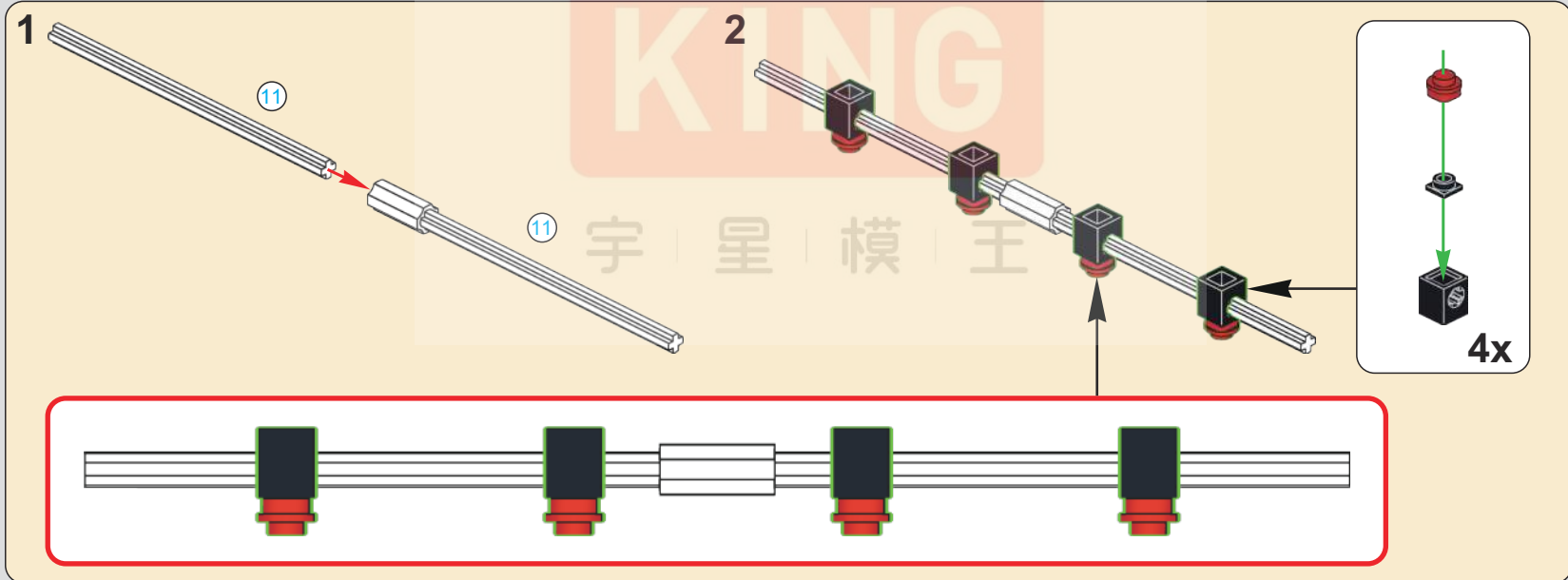
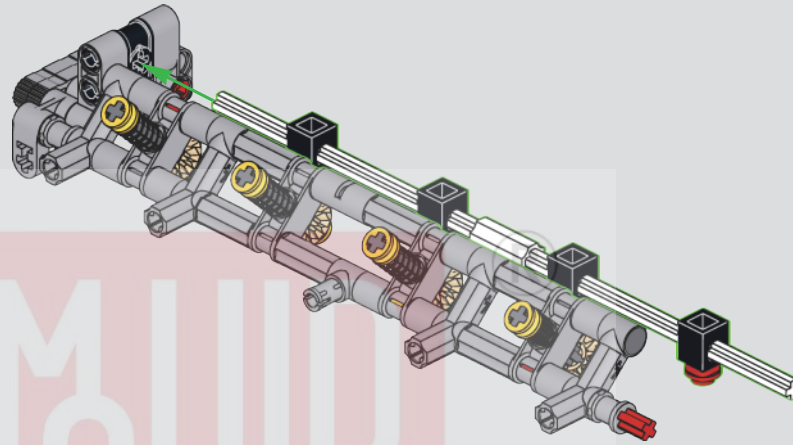

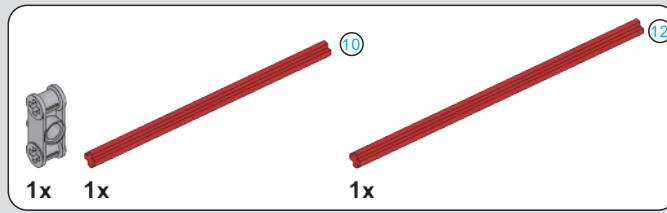
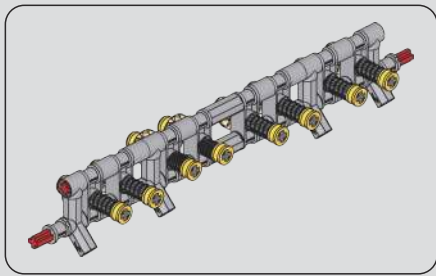

217

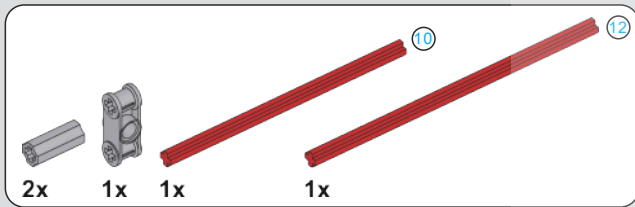

218

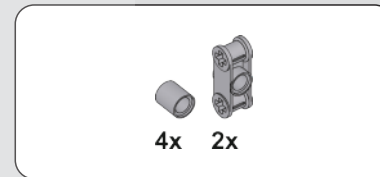
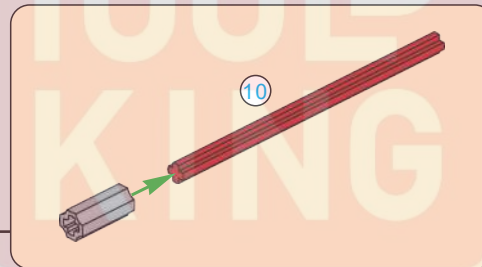

219

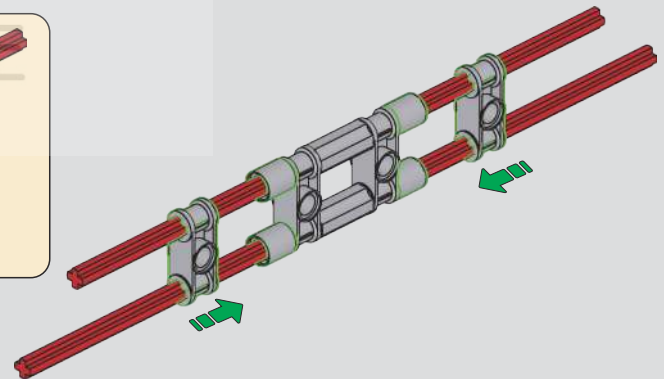
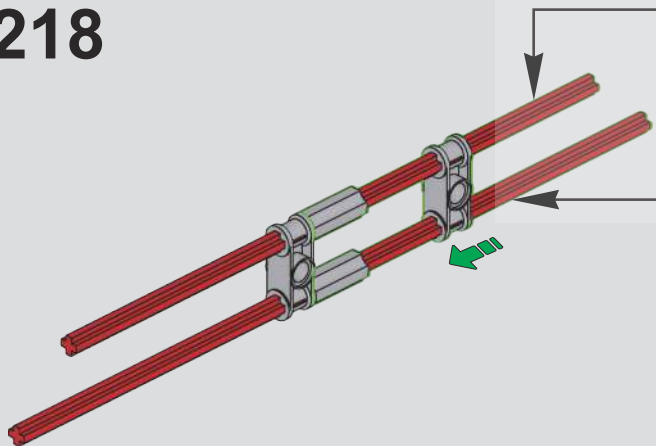

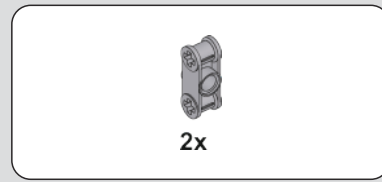
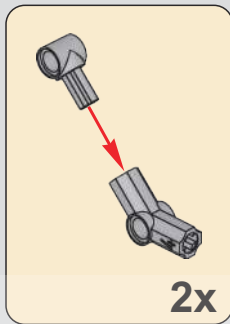
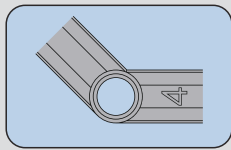
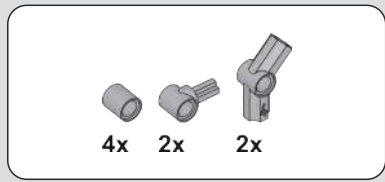

220

221

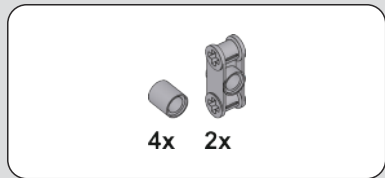
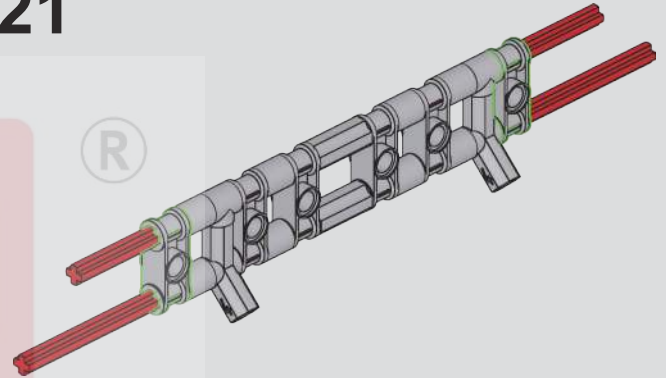
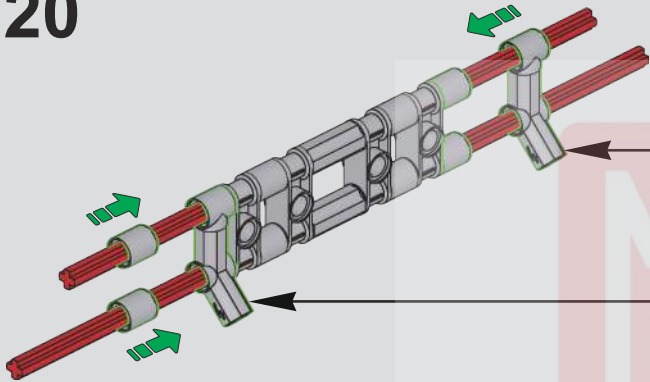

222

223

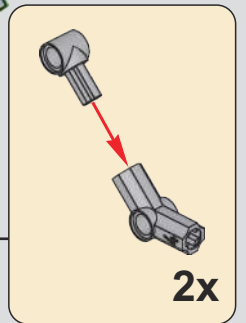
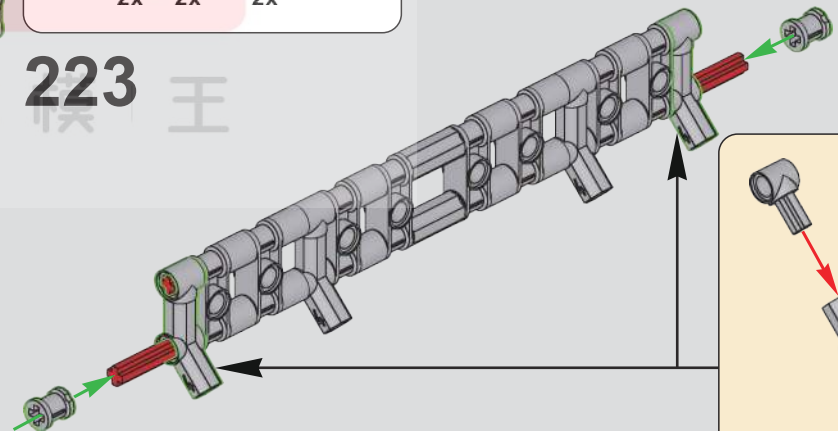
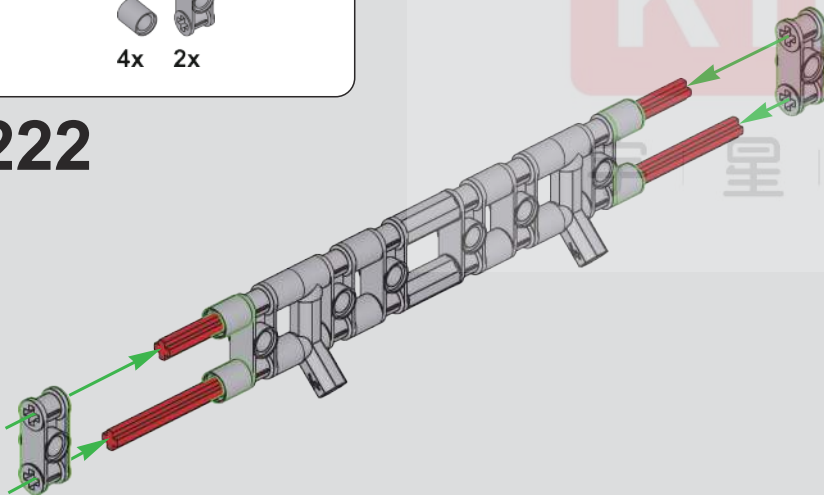

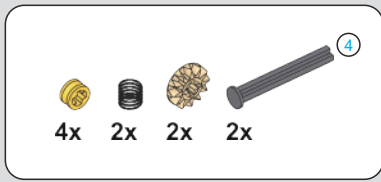

224

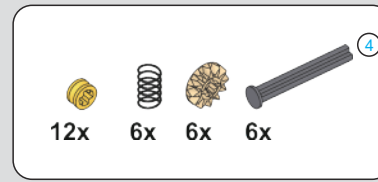
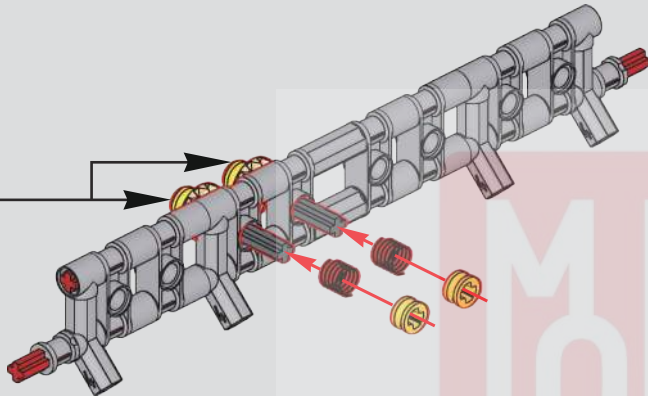
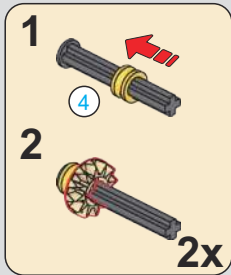

225

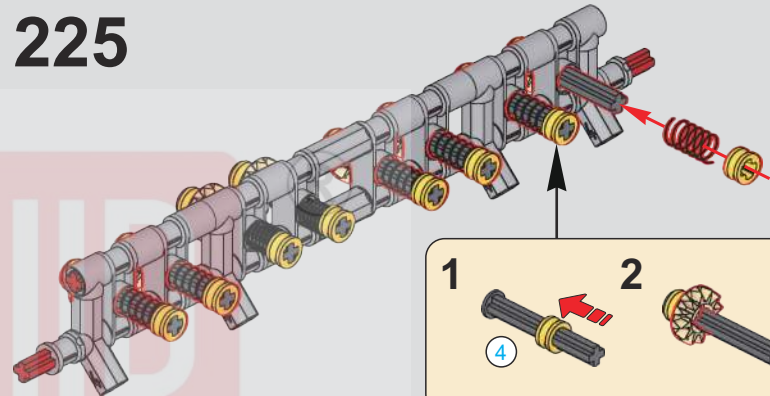
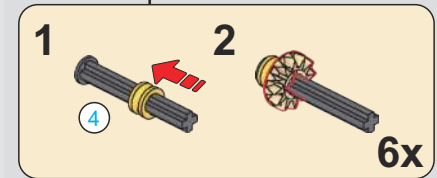

226

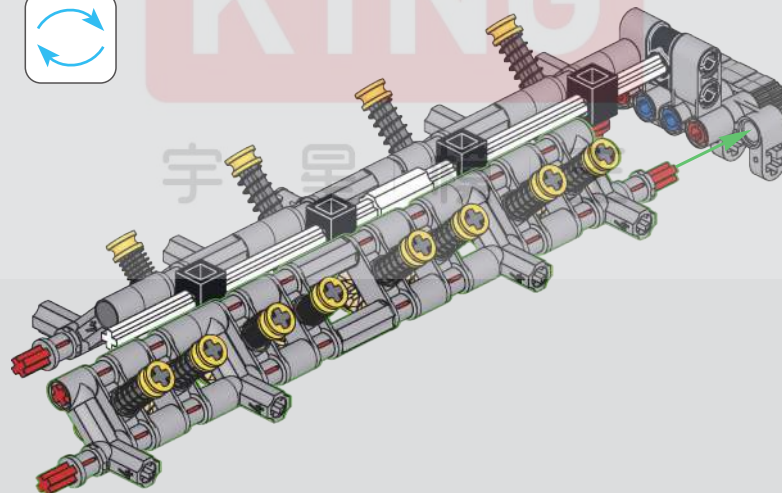

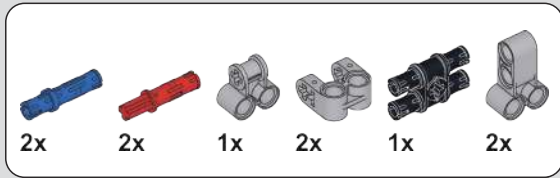

227

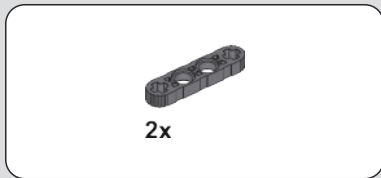
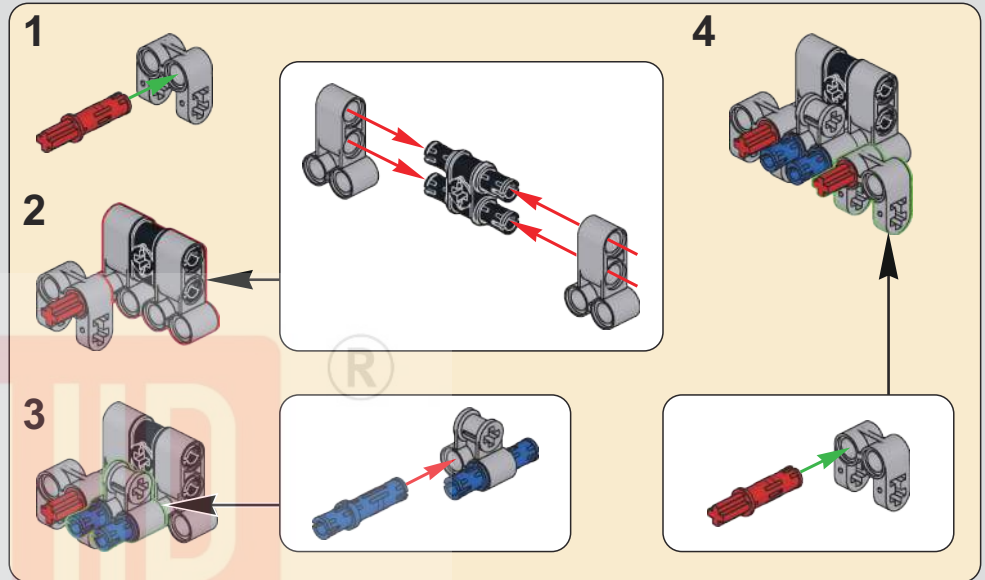
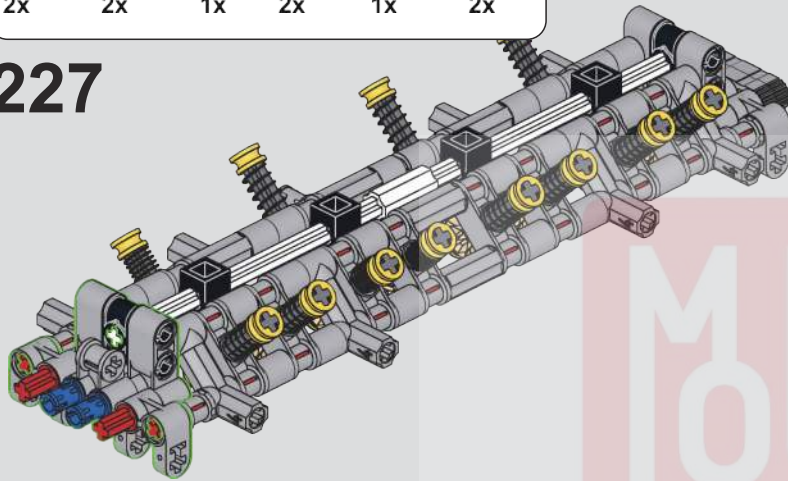

228

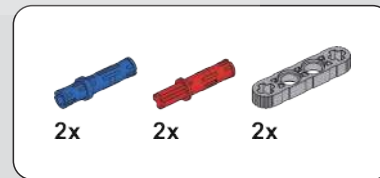
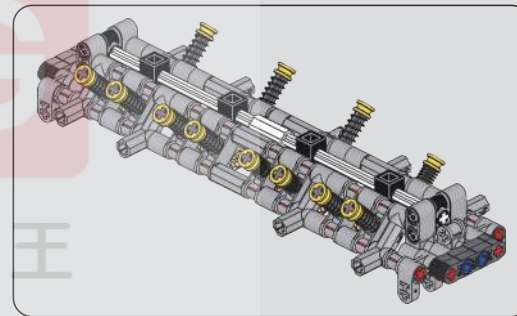
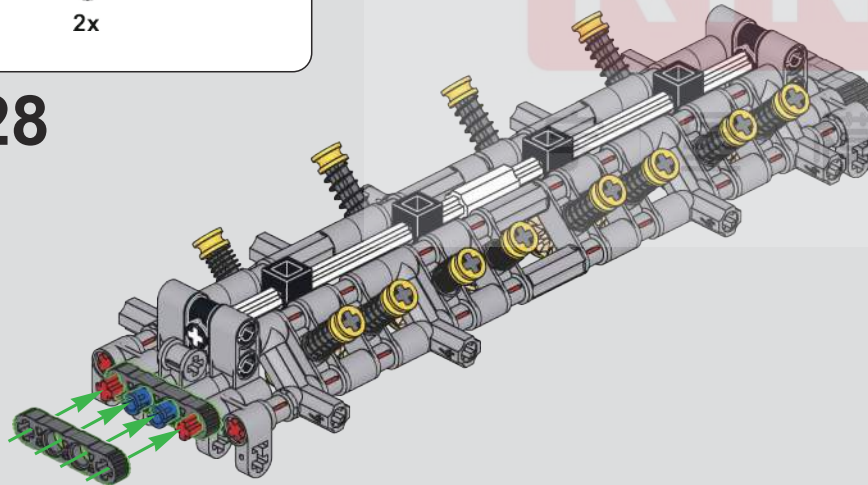

229

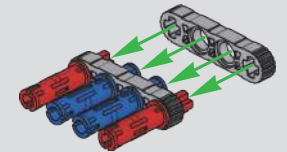

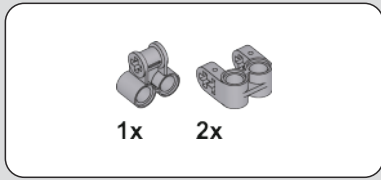

230

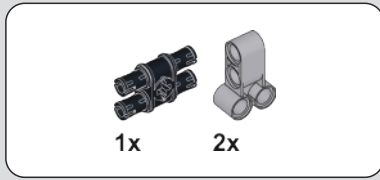

231

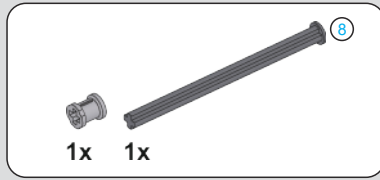

232

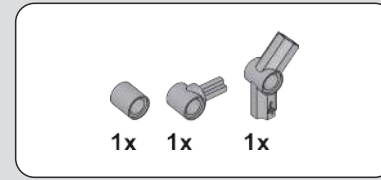

233

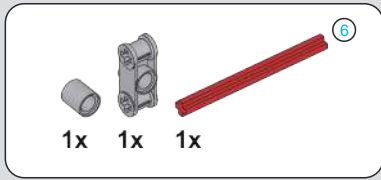
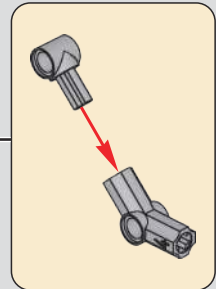
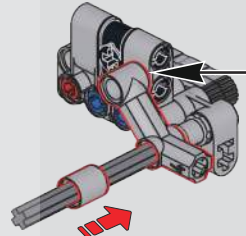
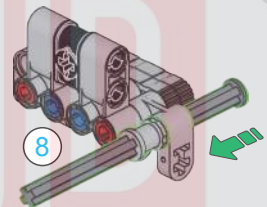
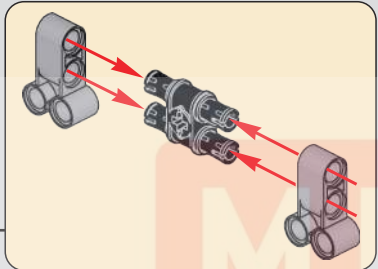
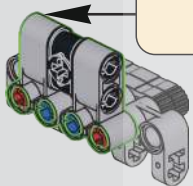
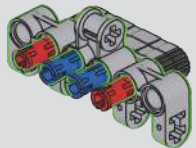

234

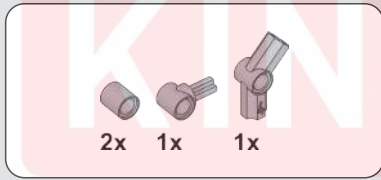

235

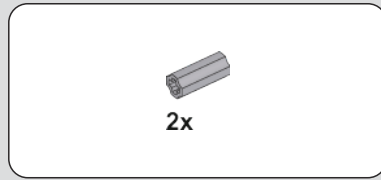
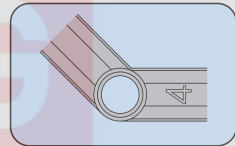

236

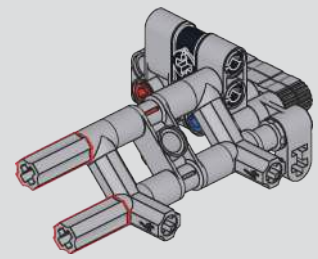
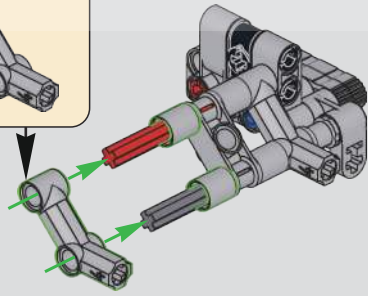
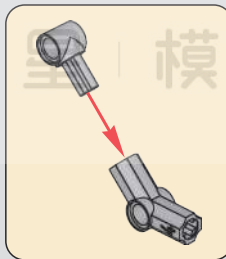
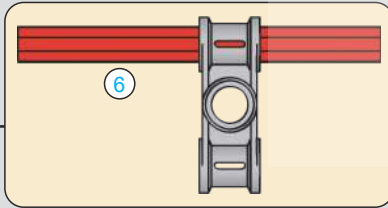
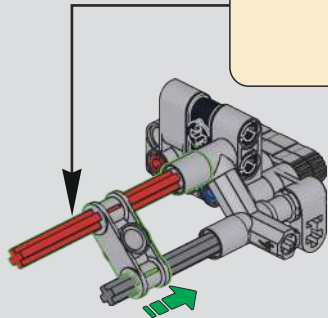

1:1

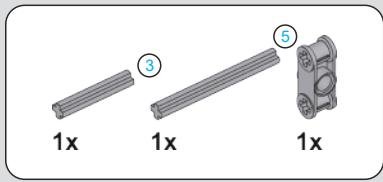

237

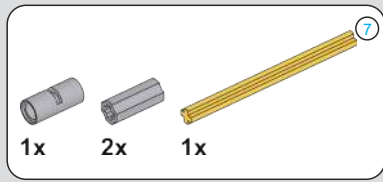
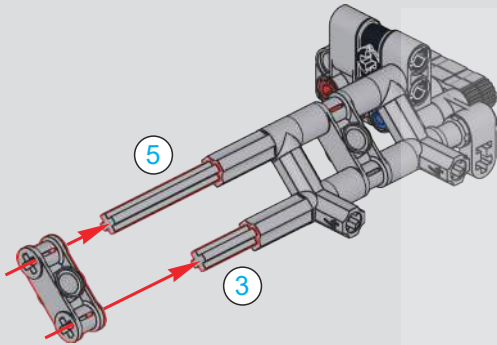

238

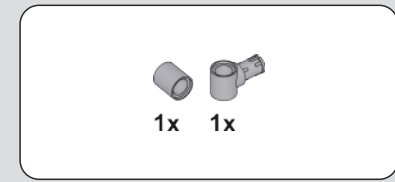
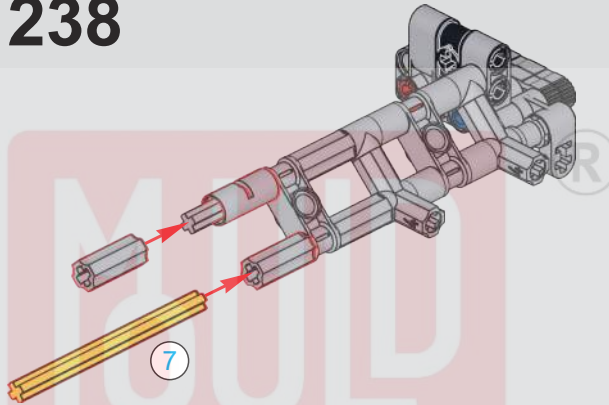

239

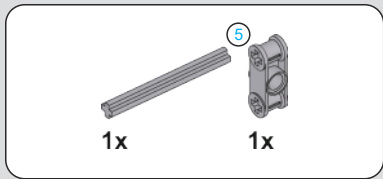
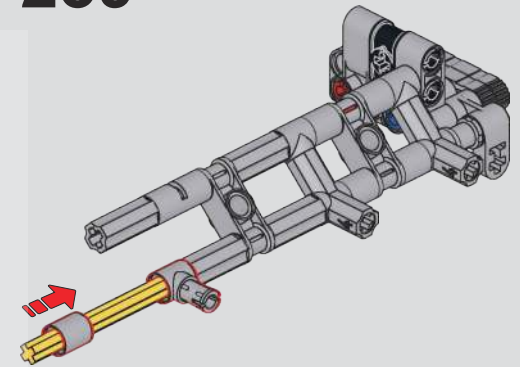

240

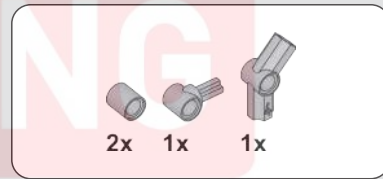
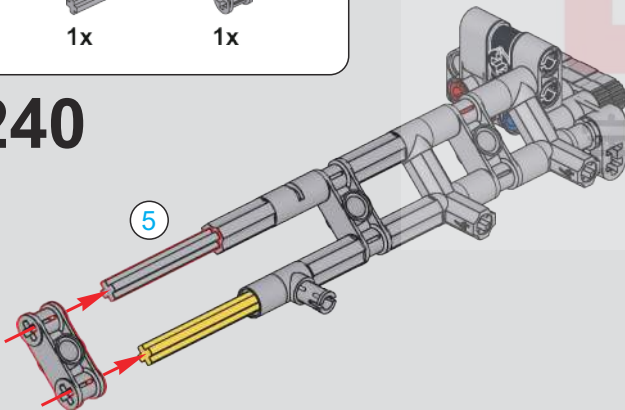

241

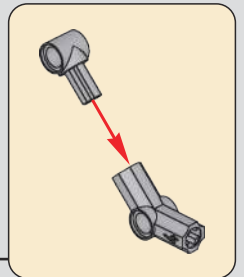
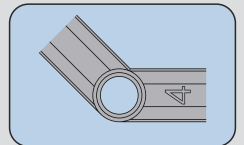
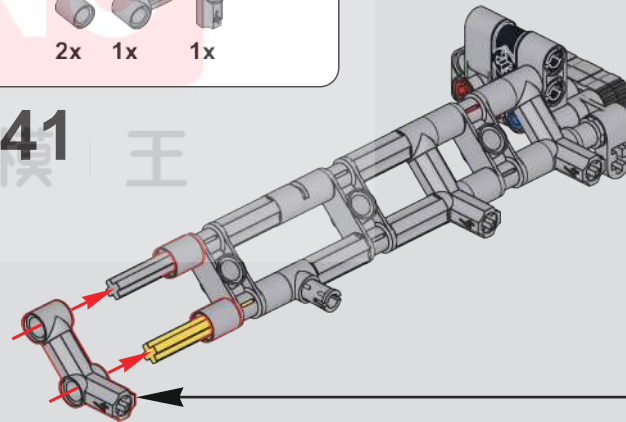

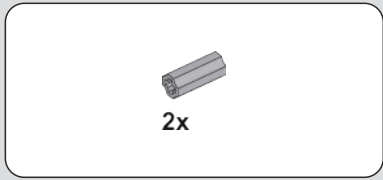

242

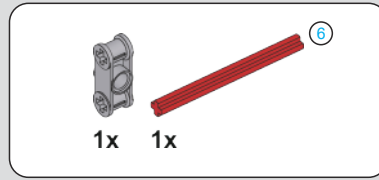
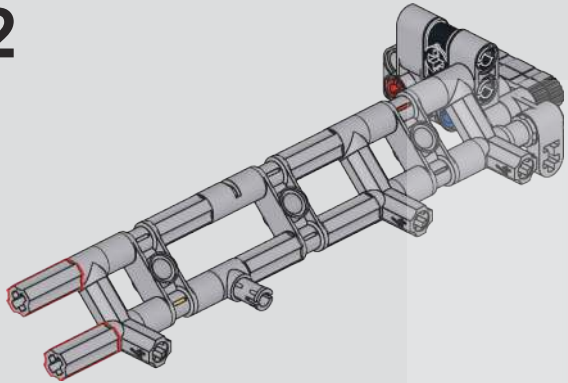

243

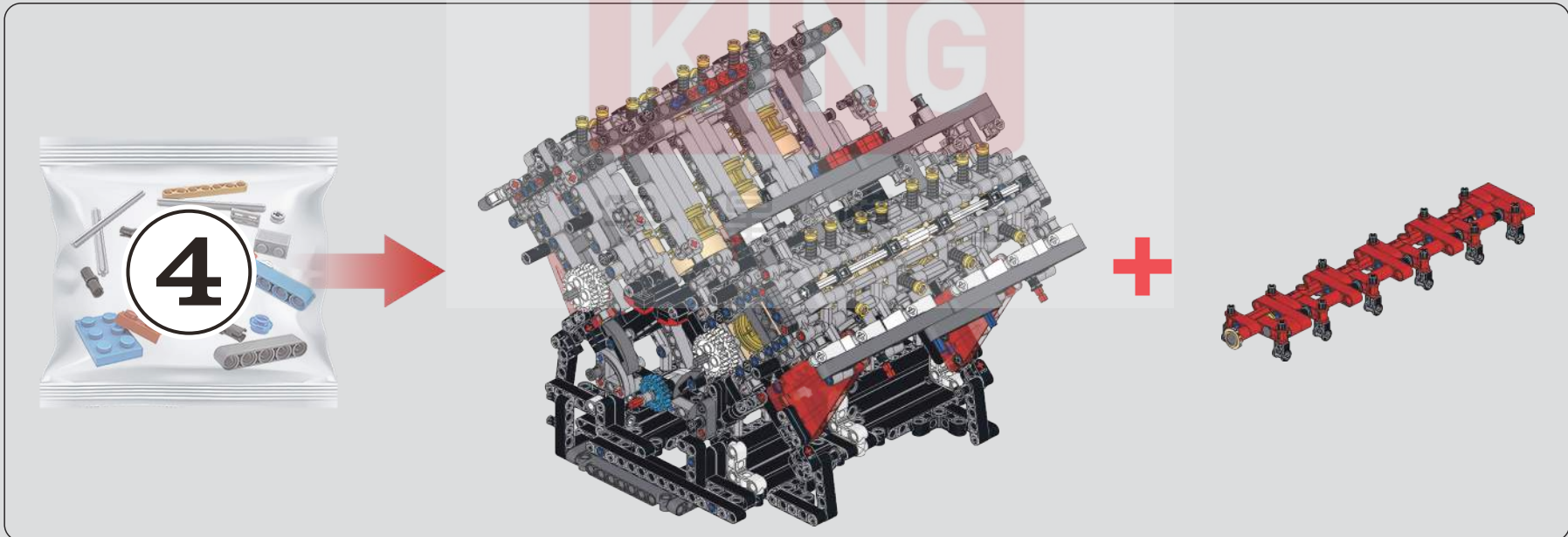
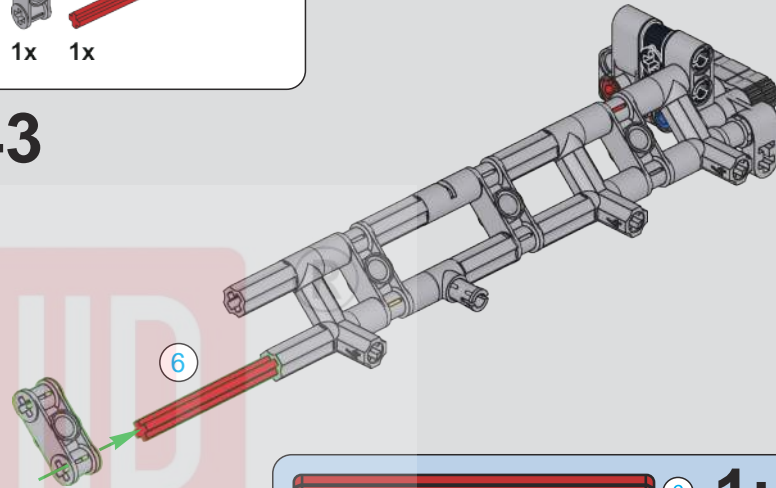

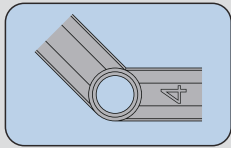
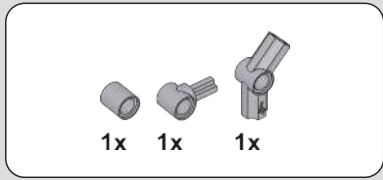

244

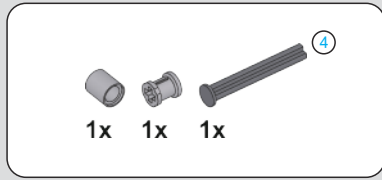

245

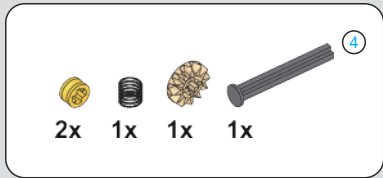
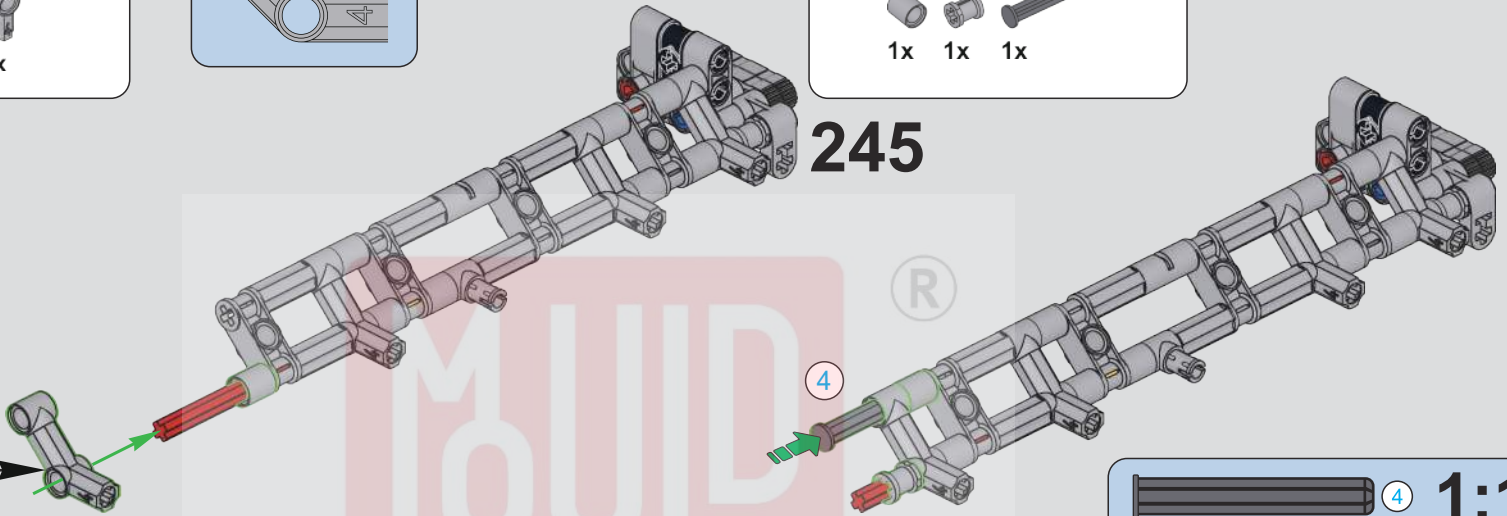
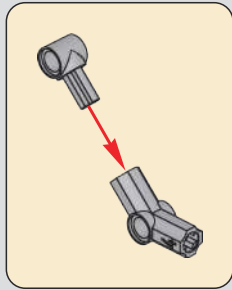

246

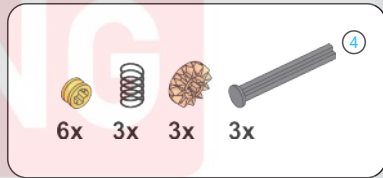

247

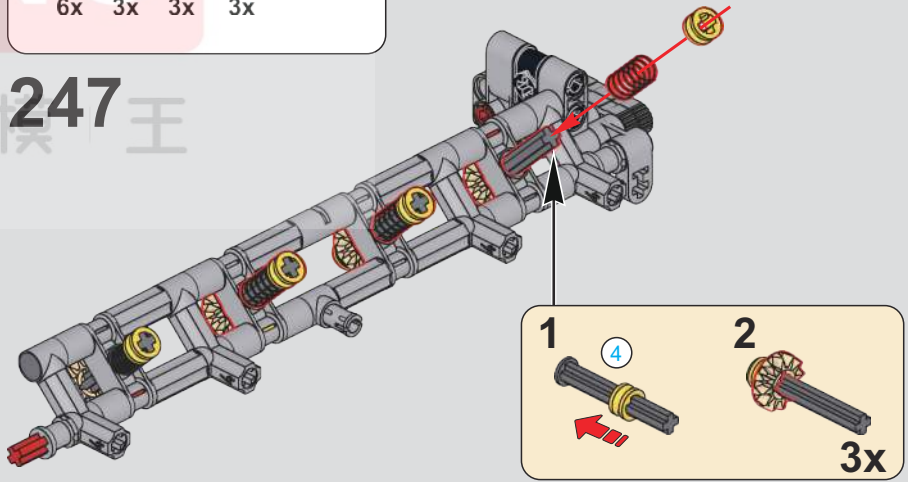
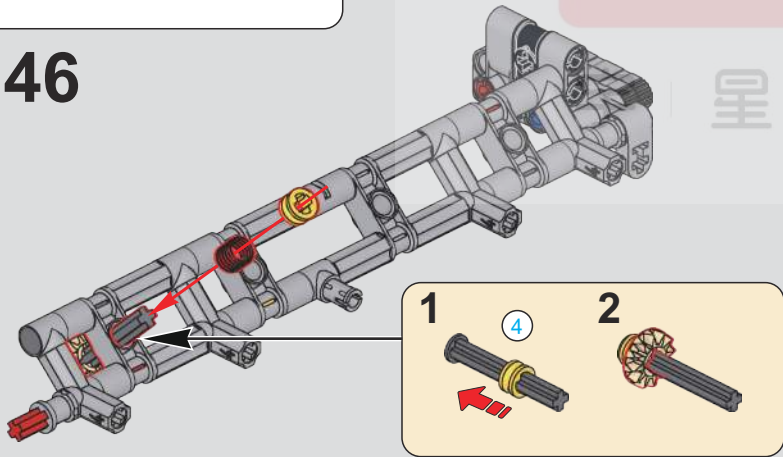

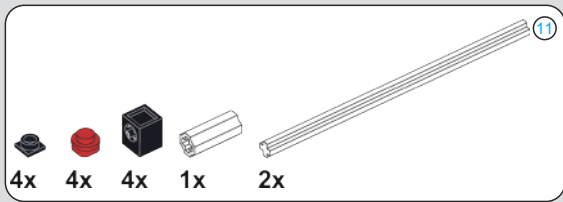

248

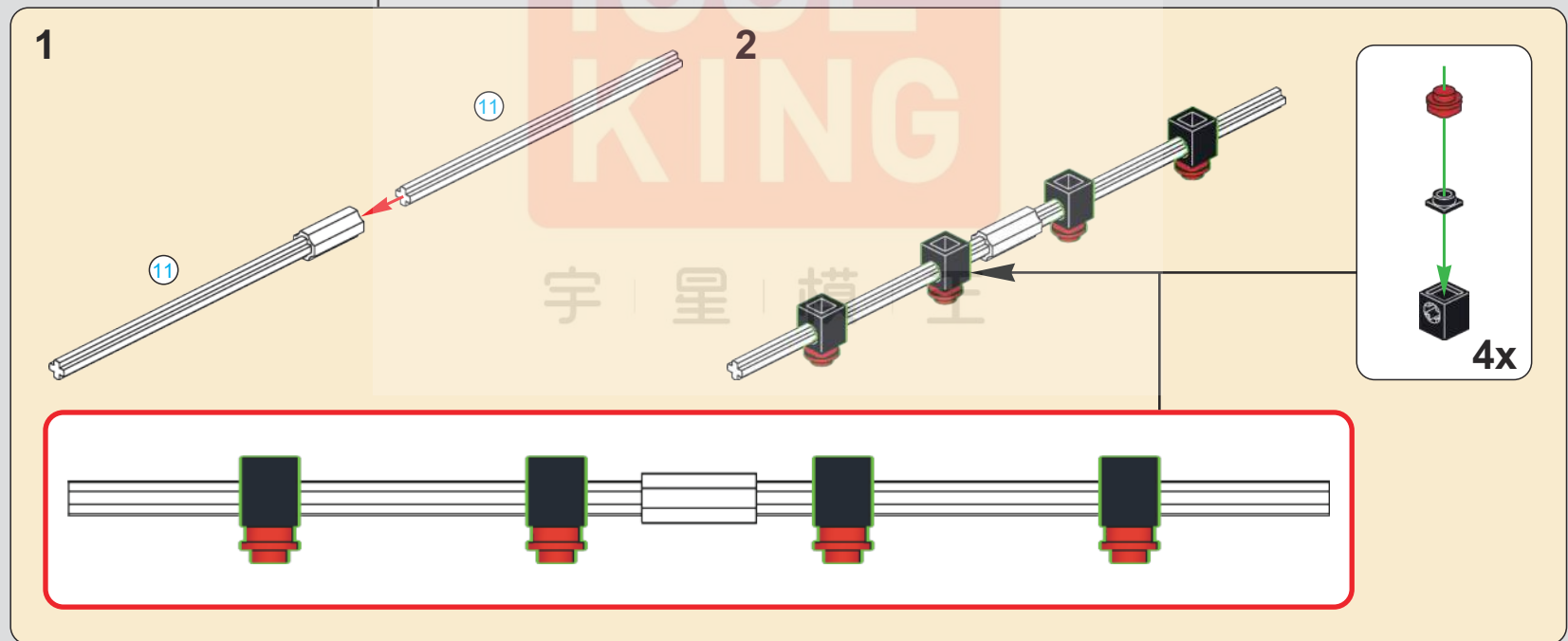
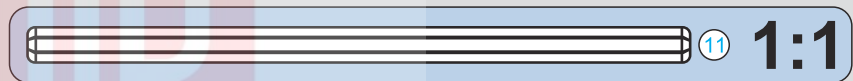
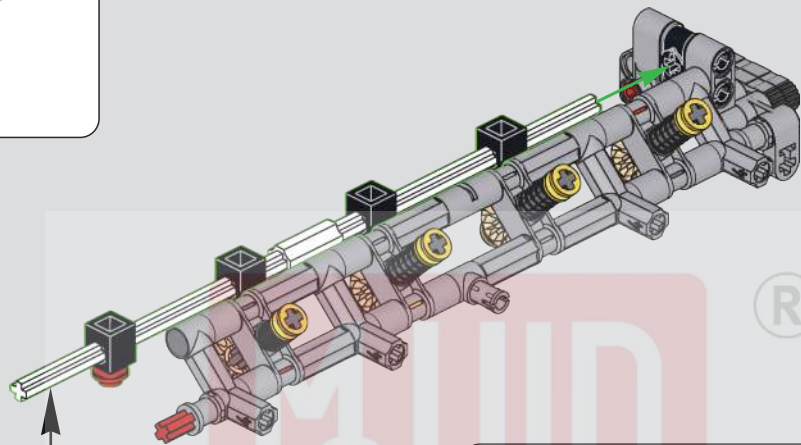

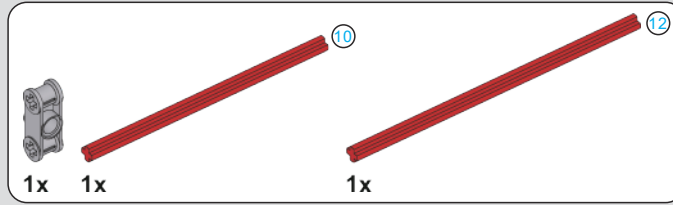
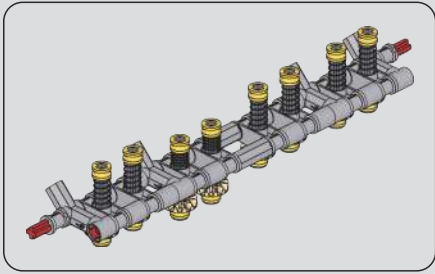

249

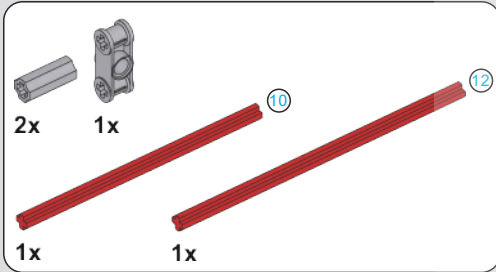
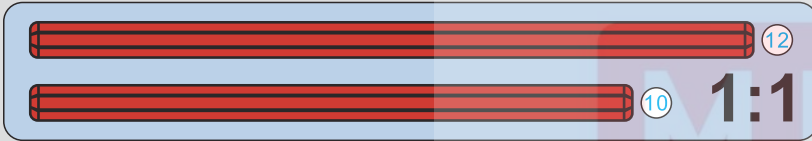
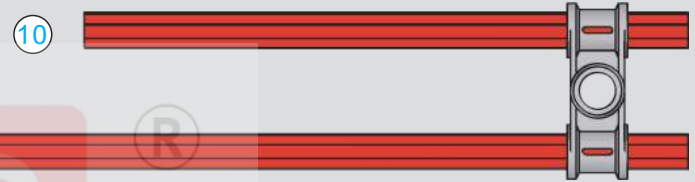

250

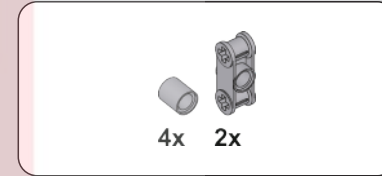
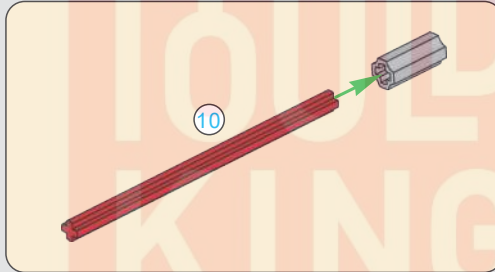

251

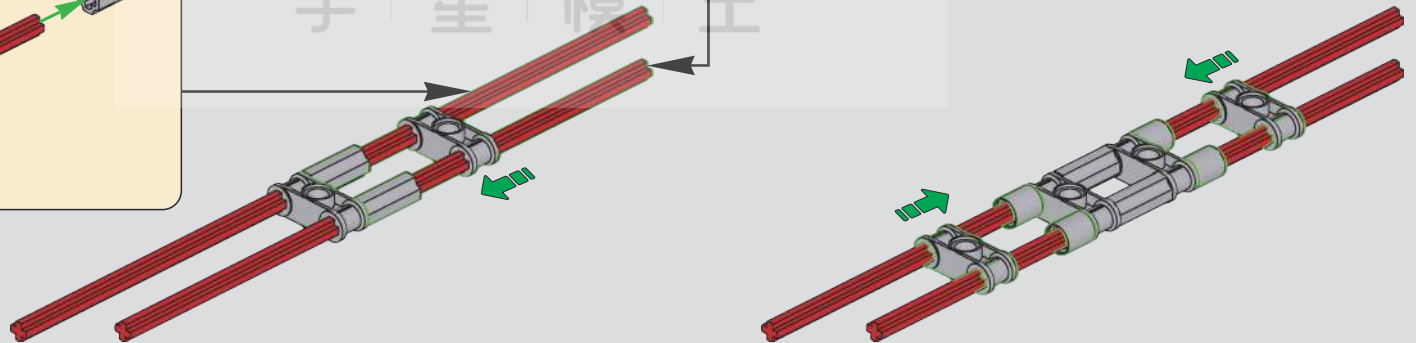
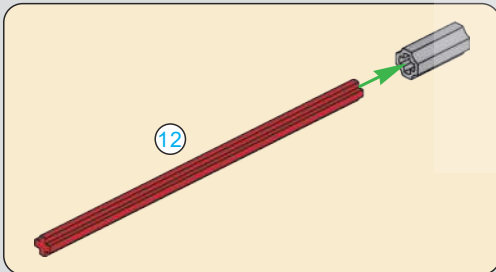

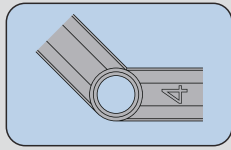
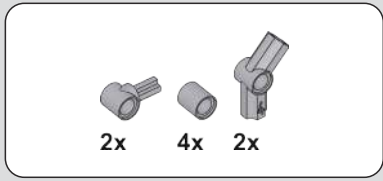

252

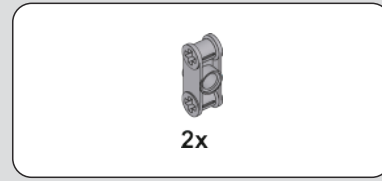
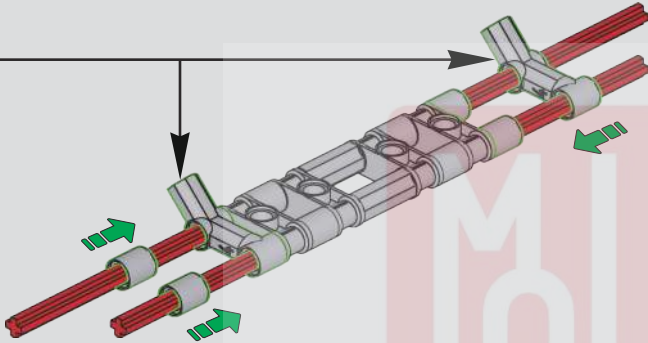
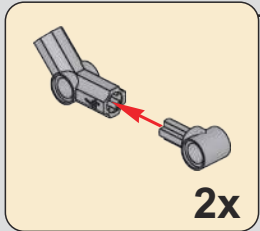

253

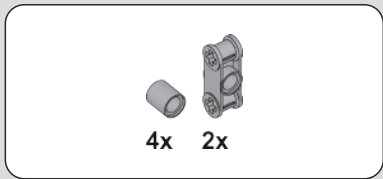
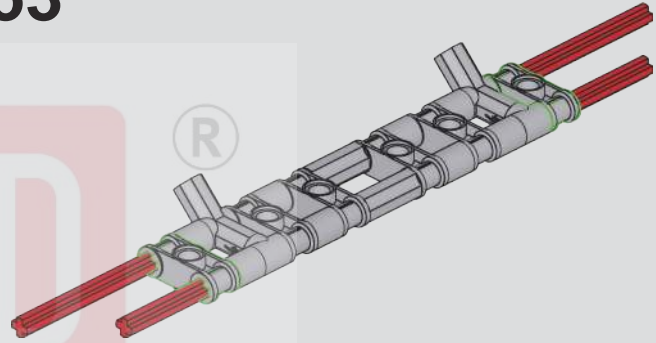

254

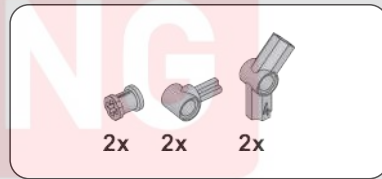
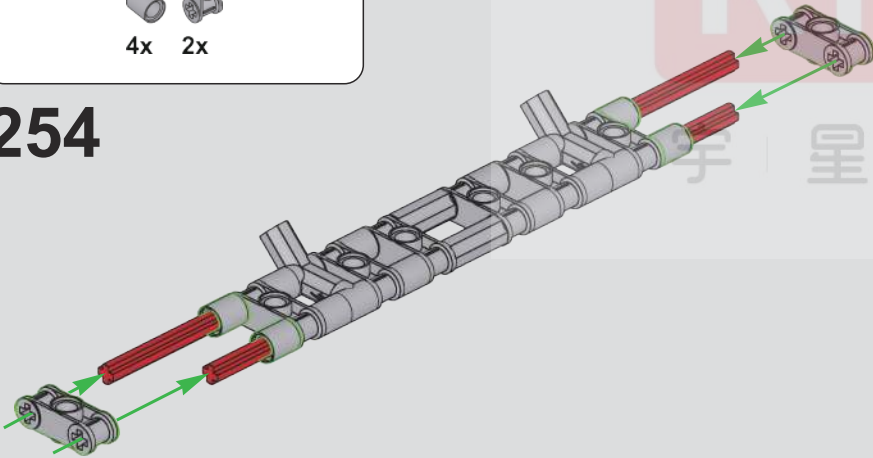

255

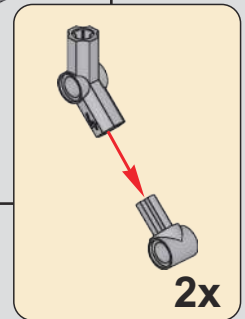
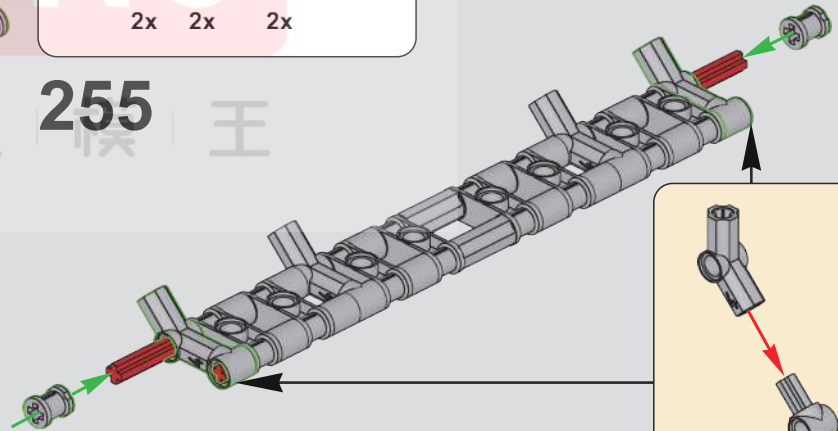

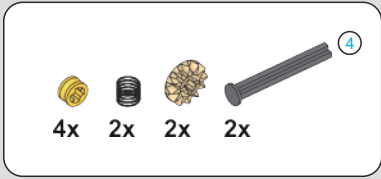

256

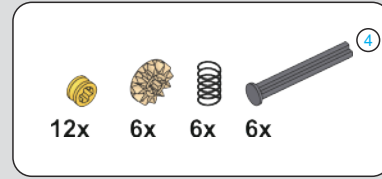
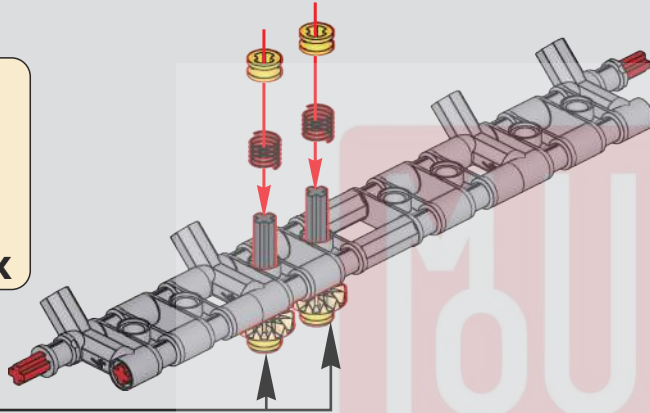
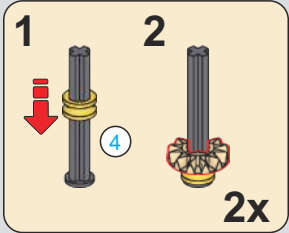

257

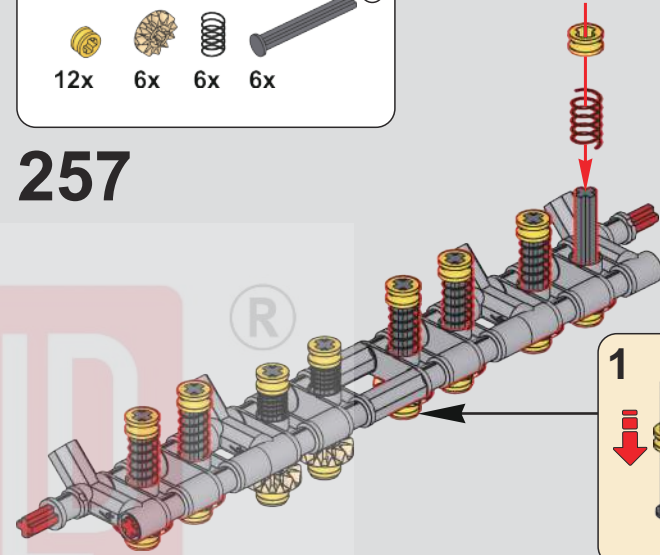
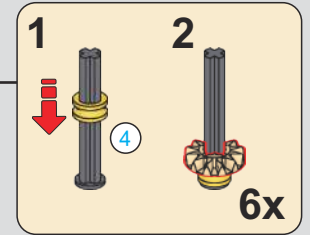

258

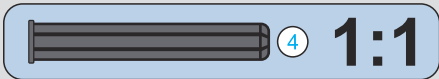
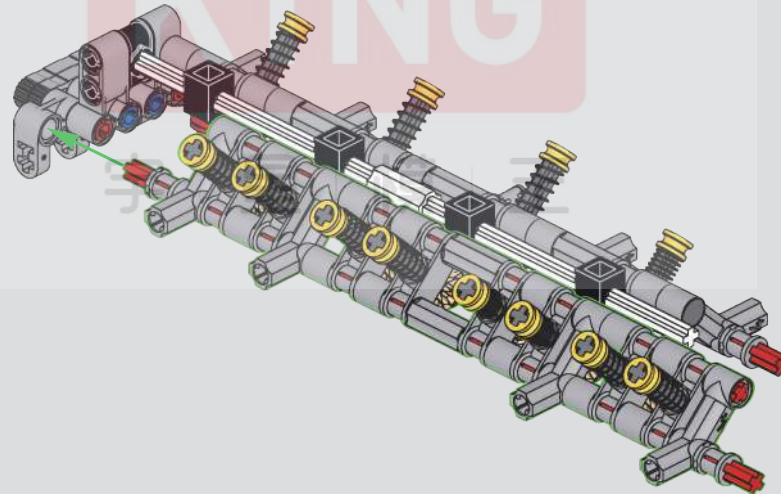

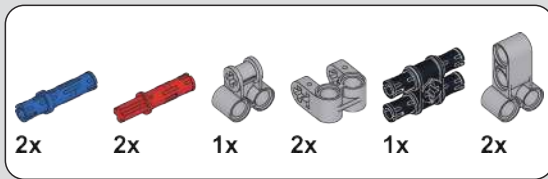

259

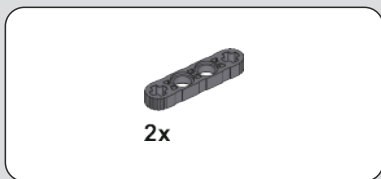
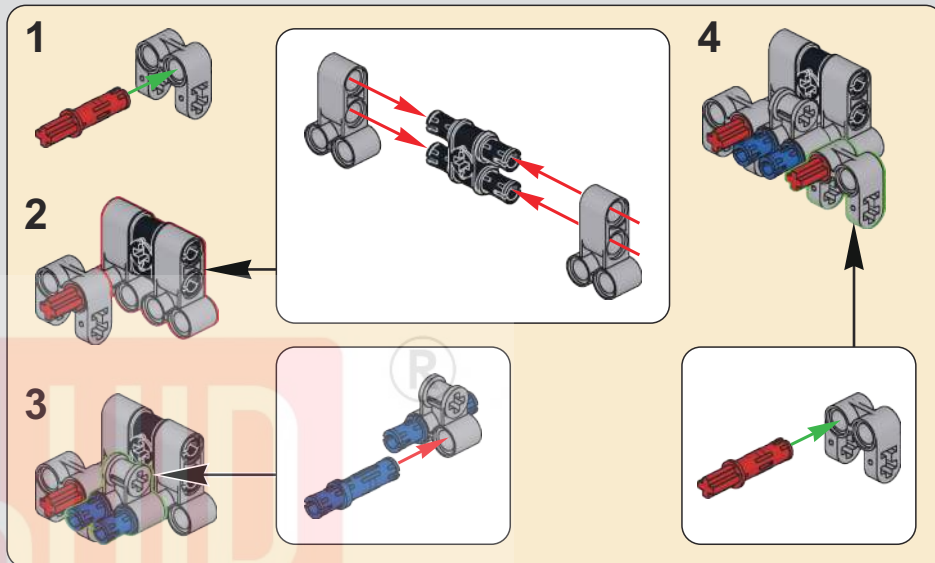
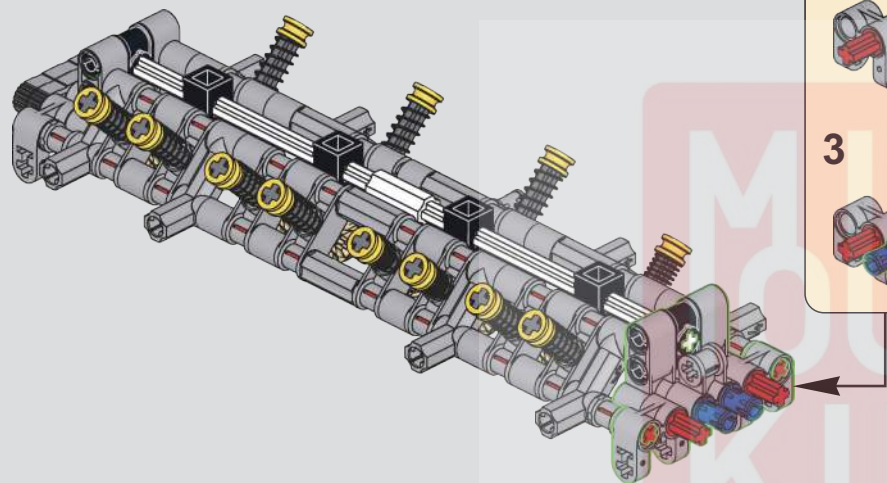

260

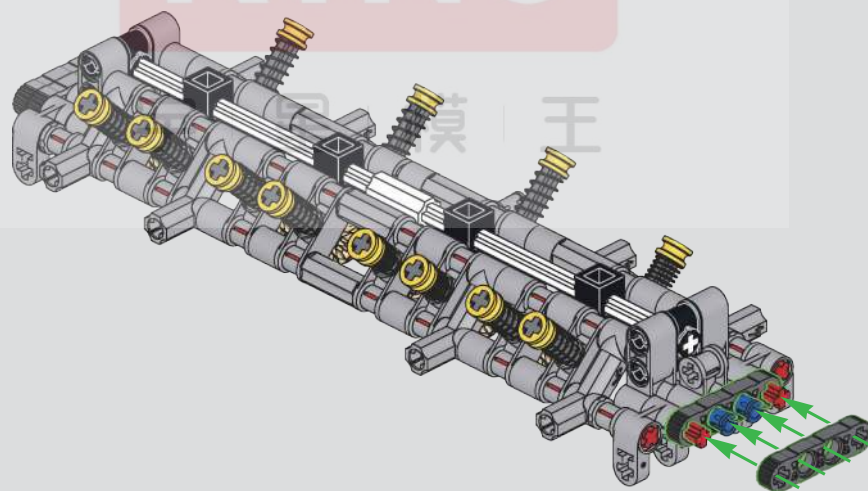

261

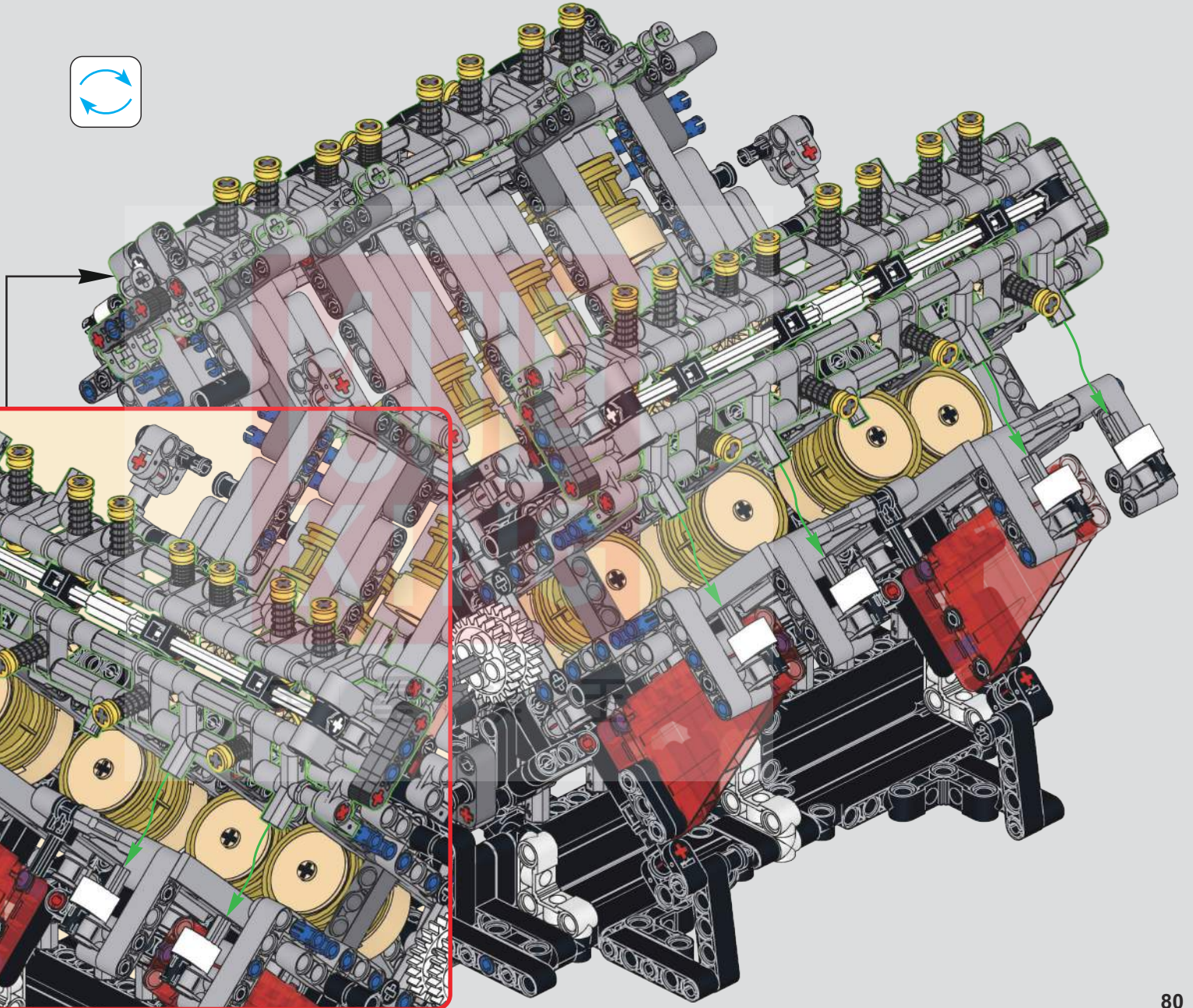
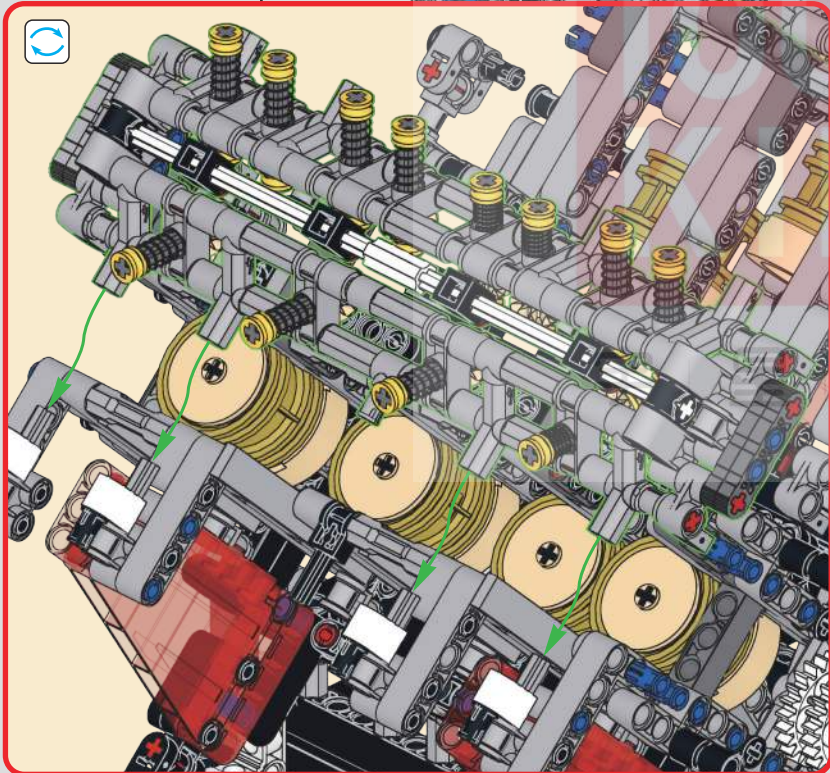



8x

262

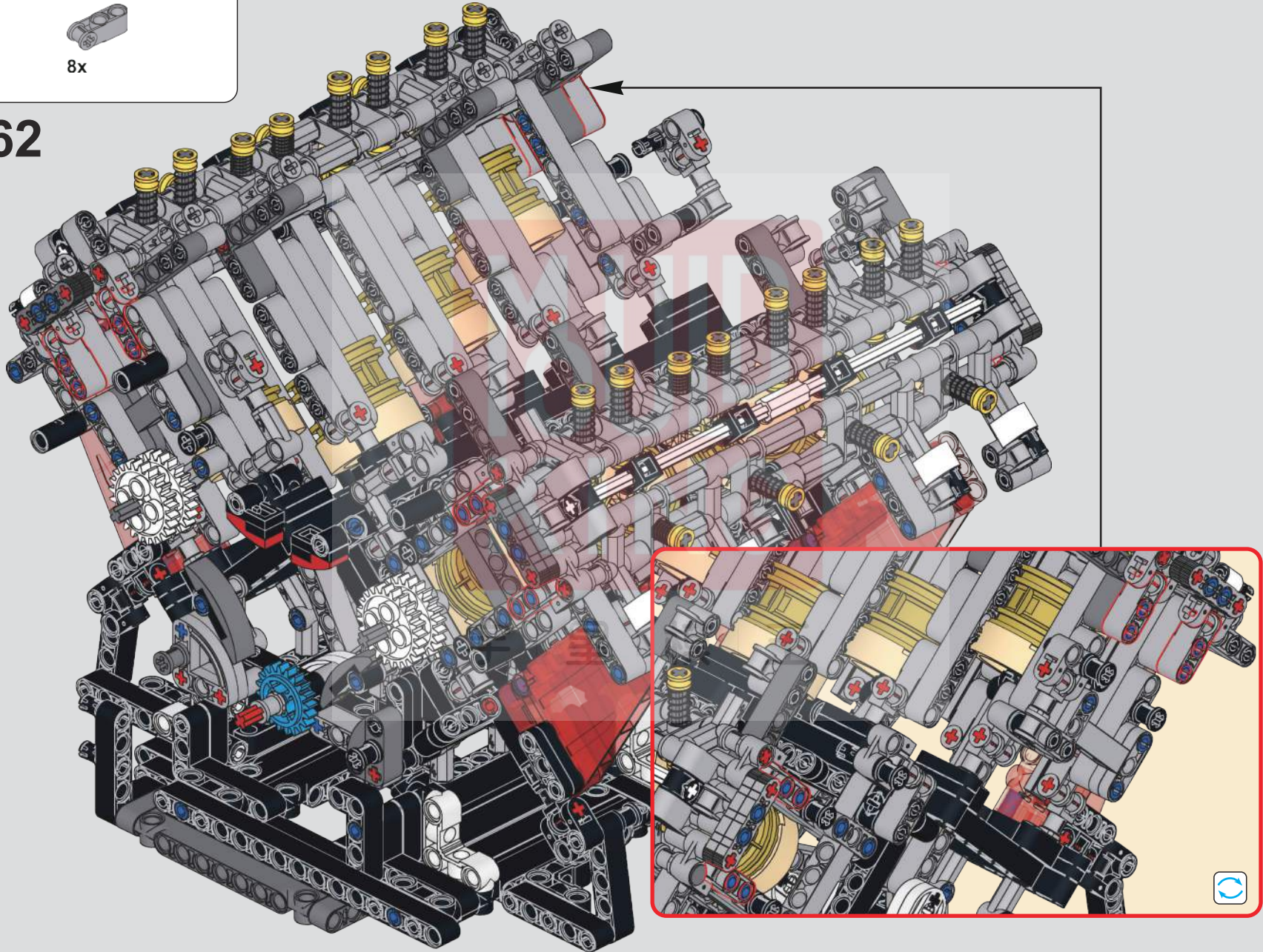

4x



263

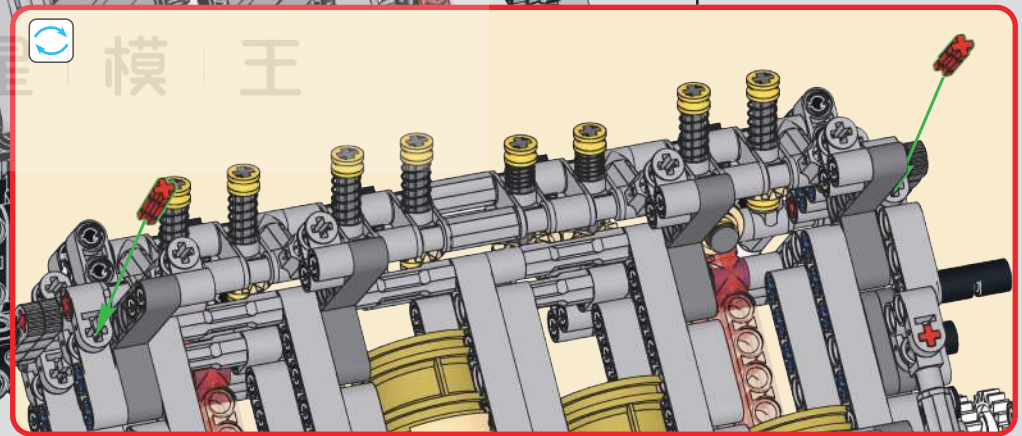
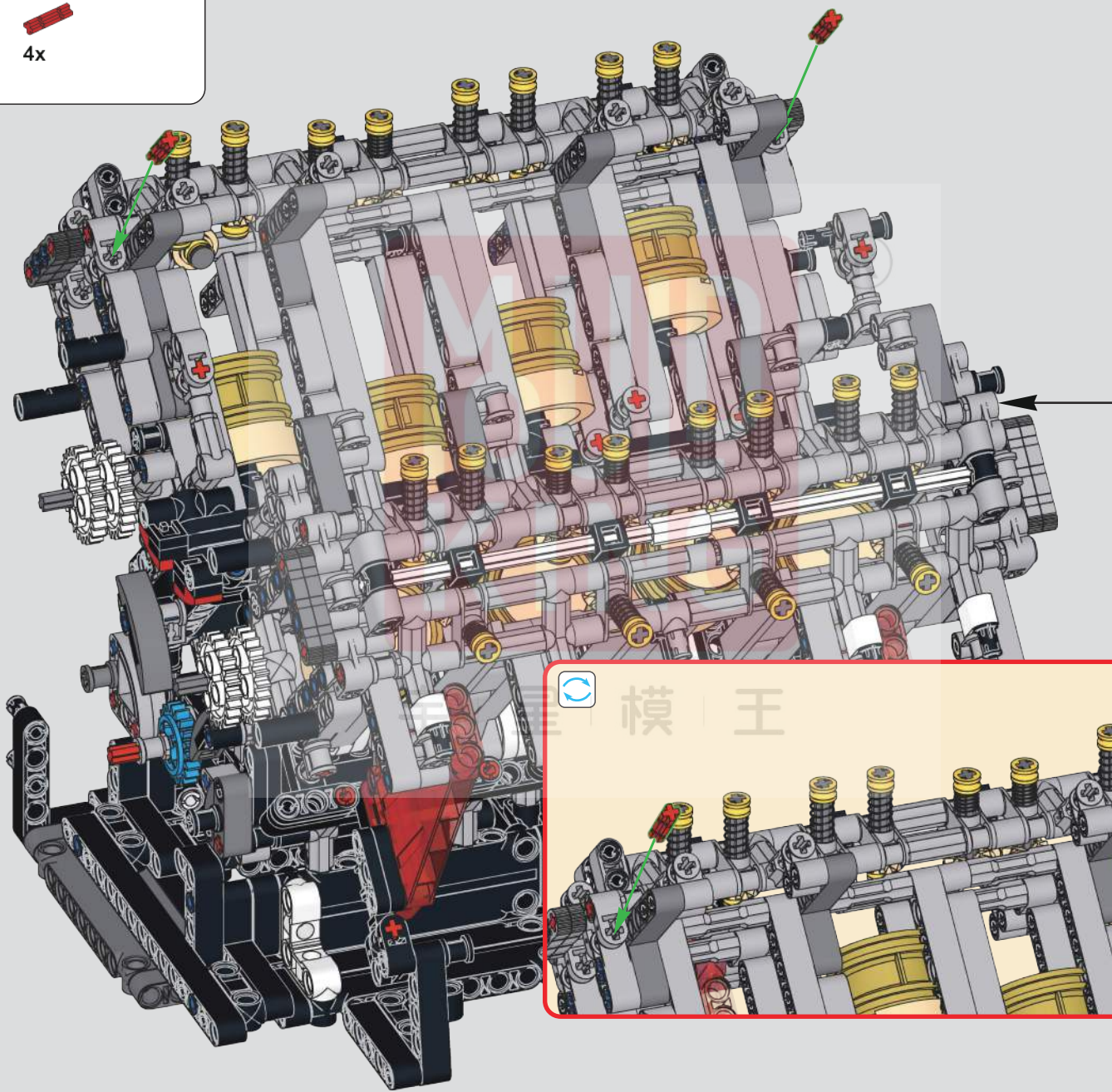



2x

264

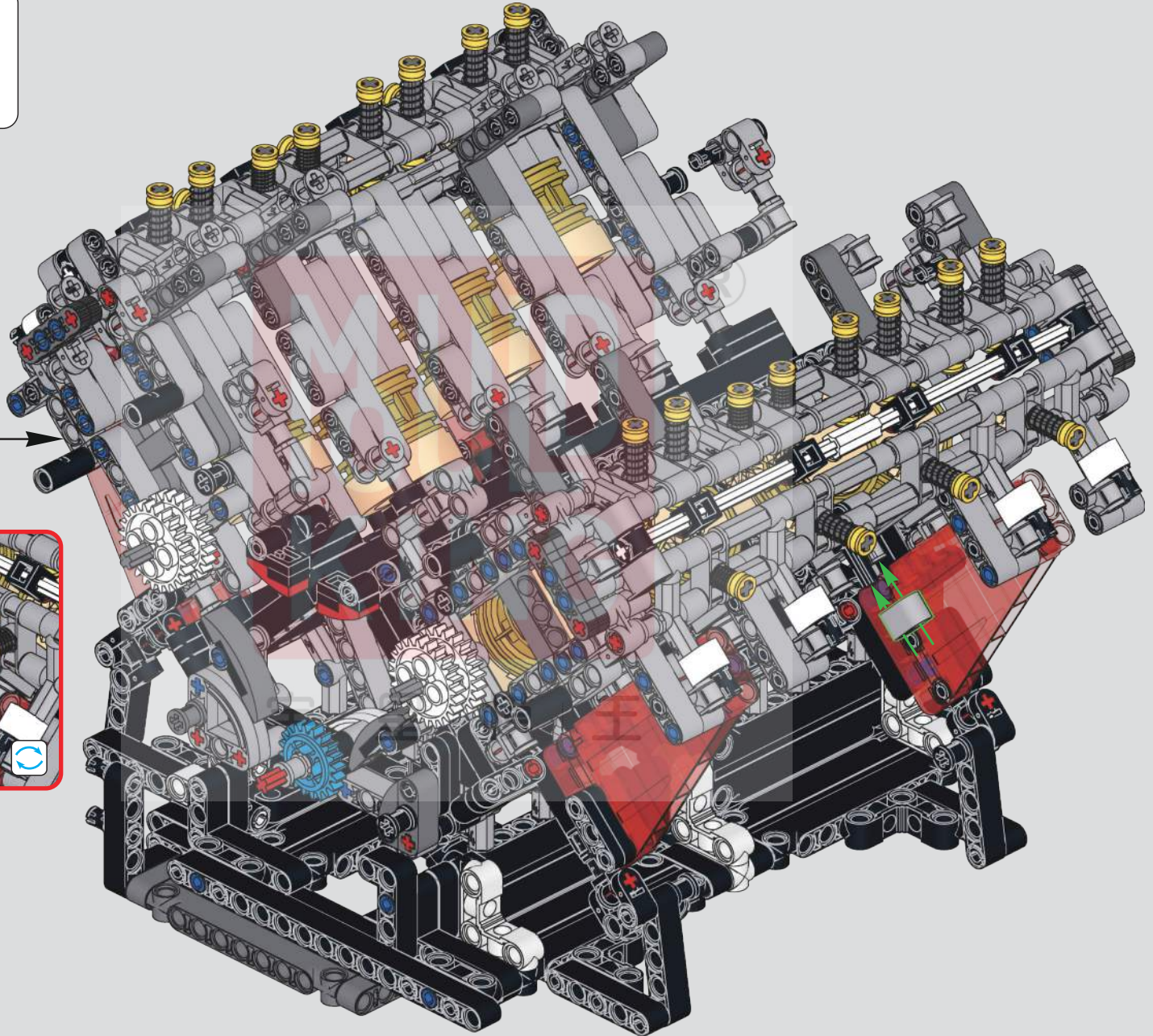
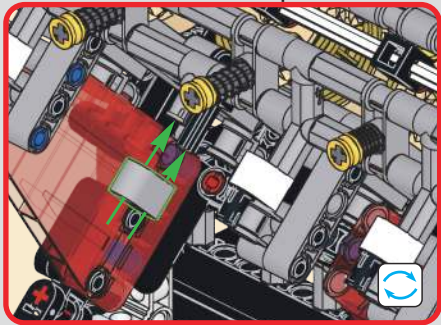

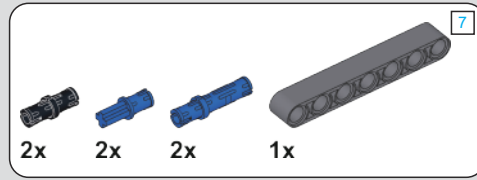
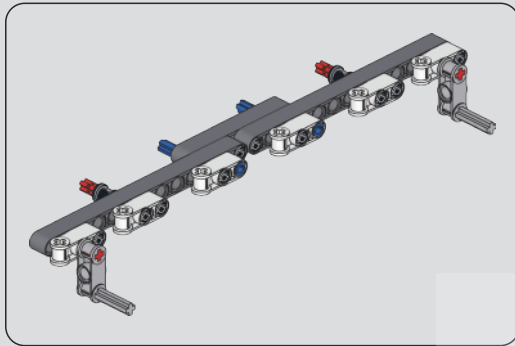

265

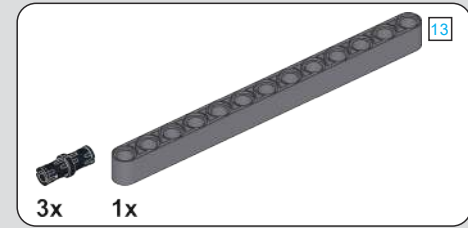

266

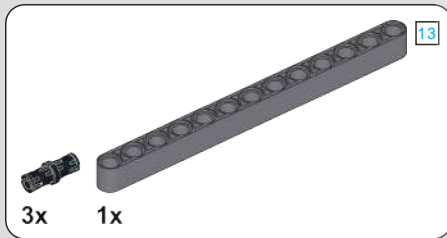
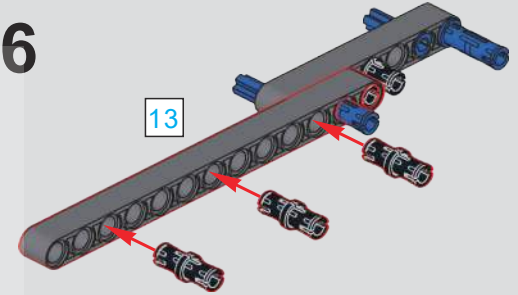
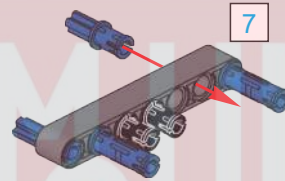

267



268

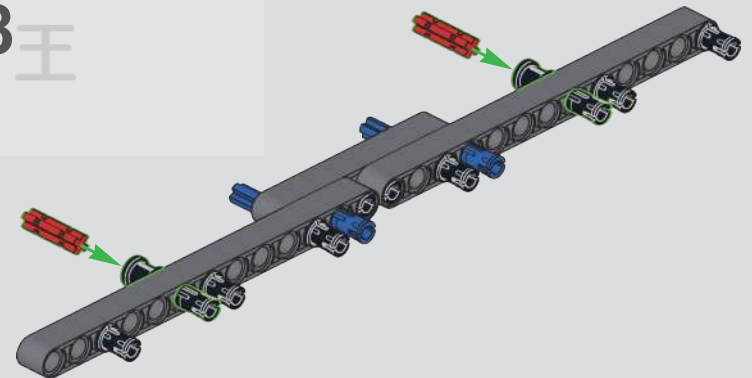
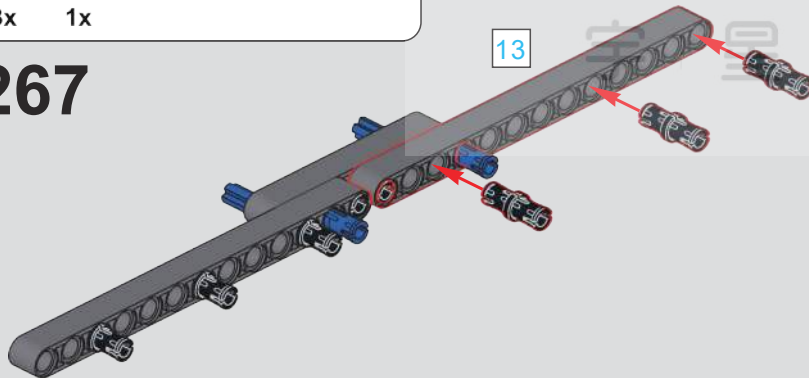

* (Plating) (电镀配件)

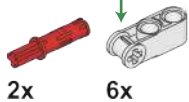

269

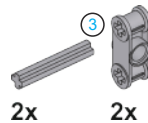
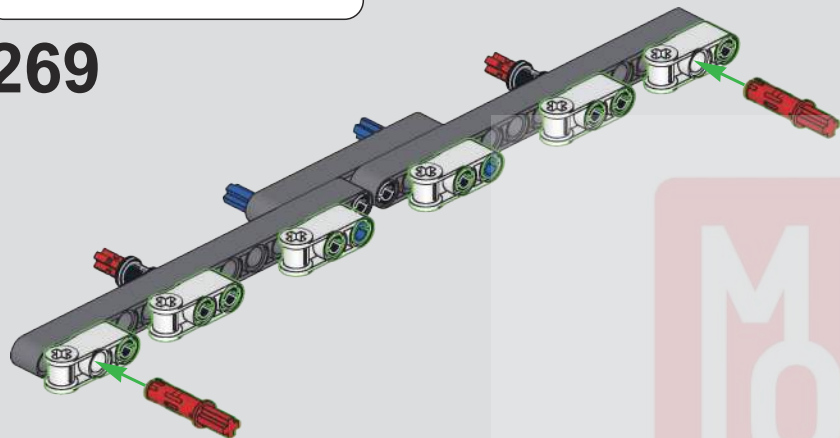

270

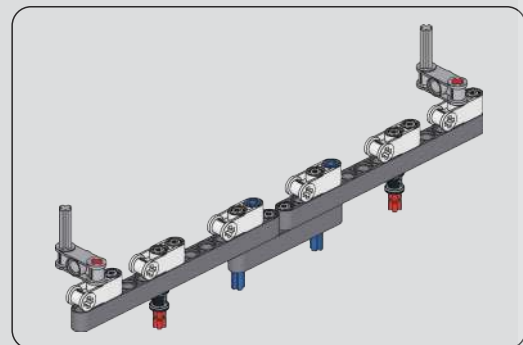
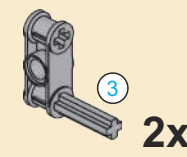
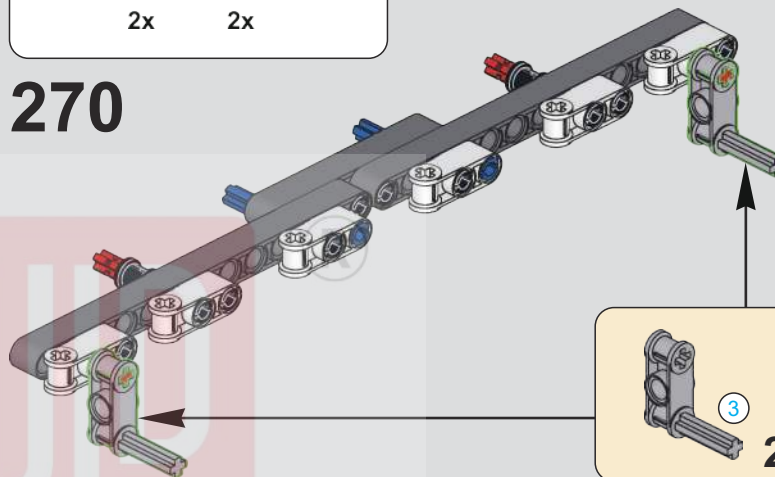

271

宇 | 星 | 模

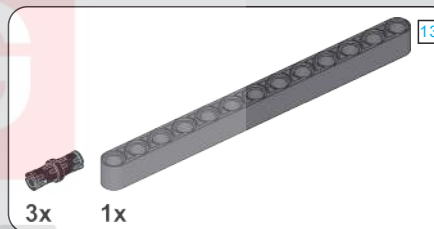
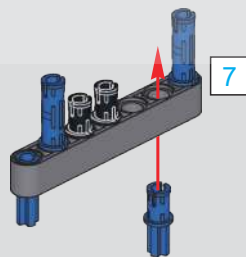

272

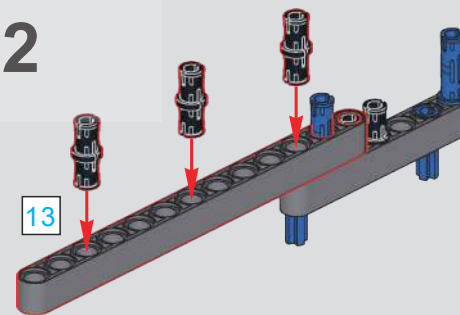

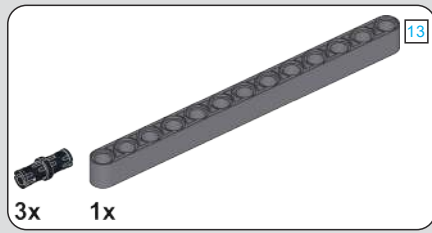

273

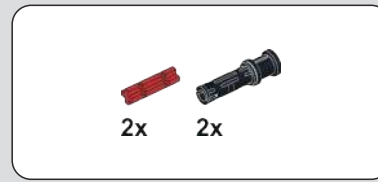
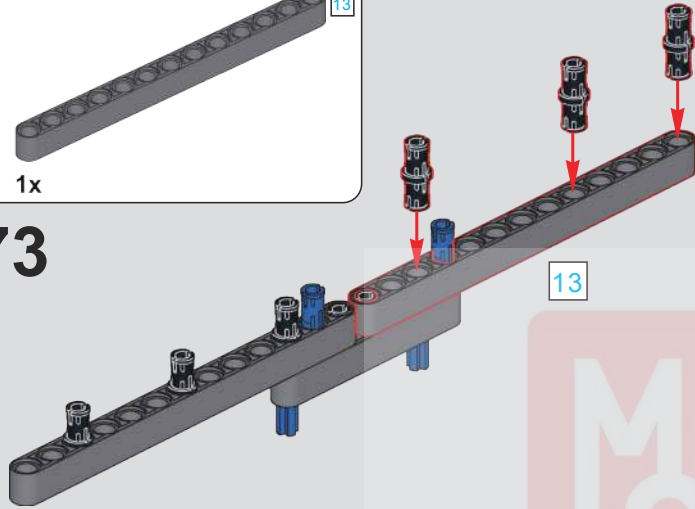

274

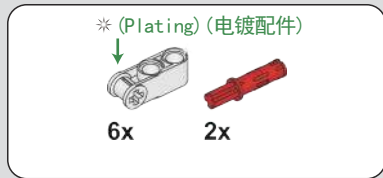
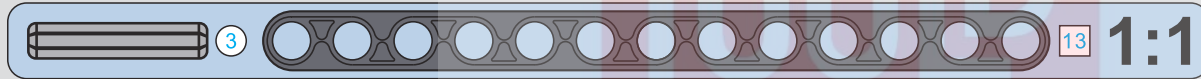
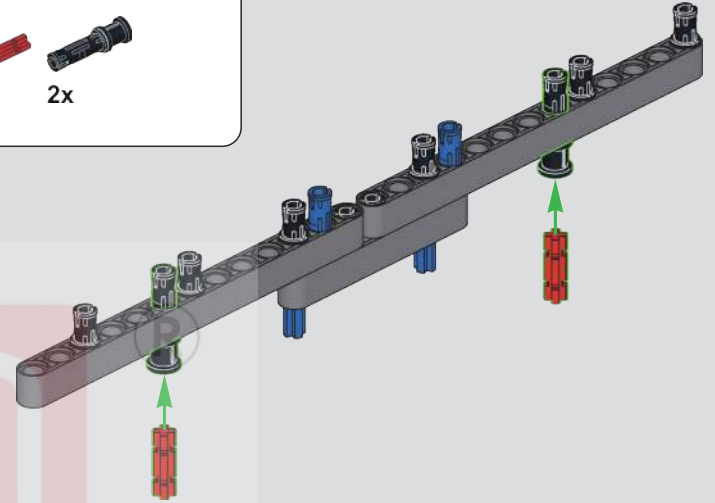

275

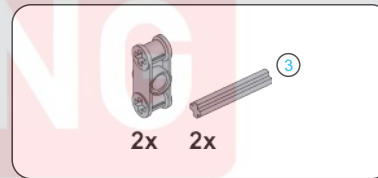
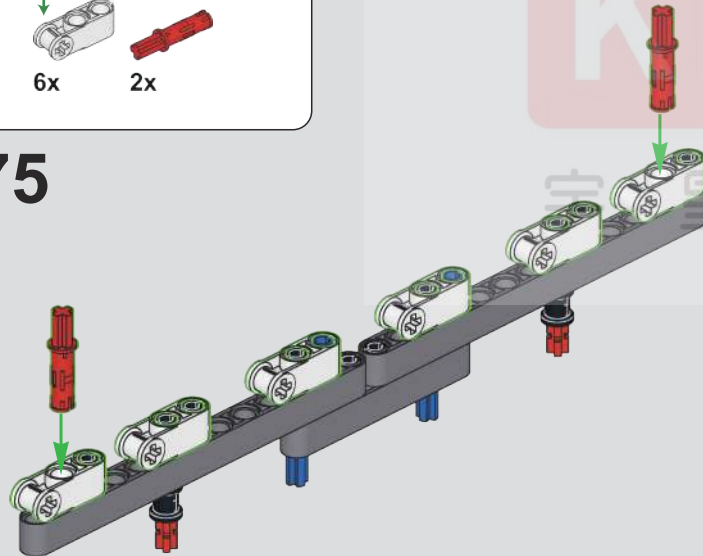

276

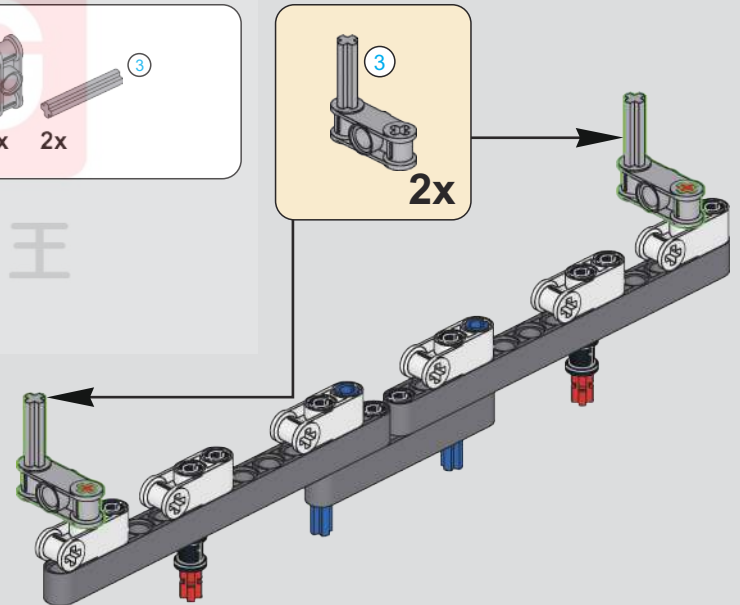

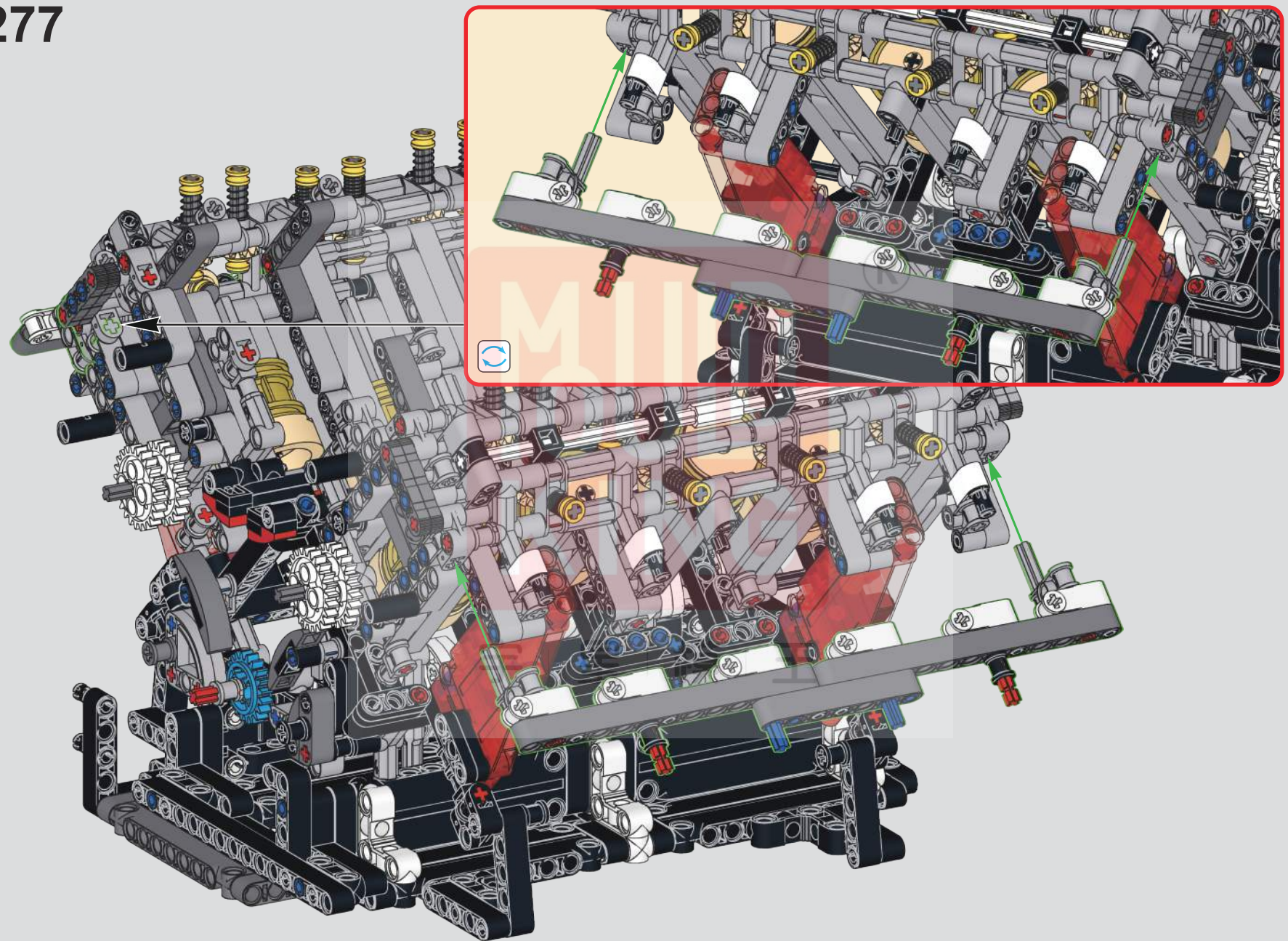

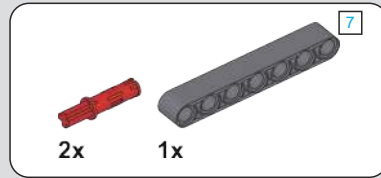
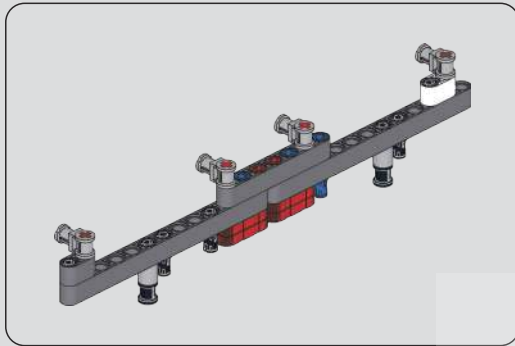

278

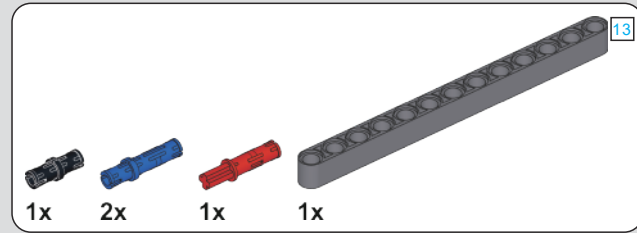

279

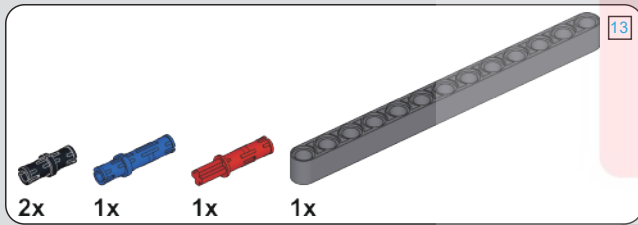
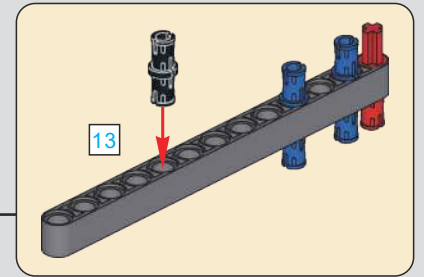
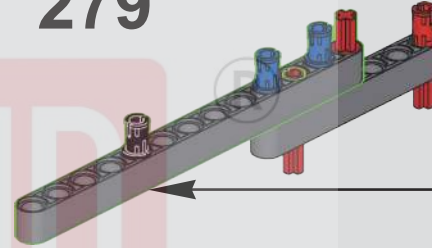
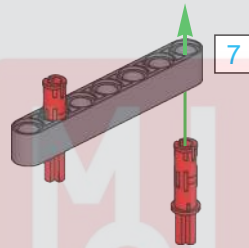

280

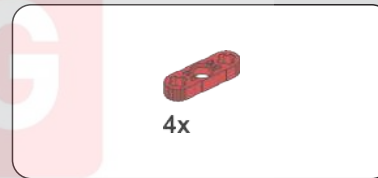

281

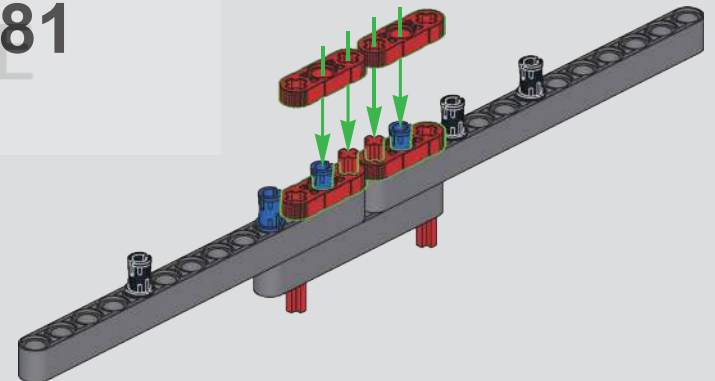
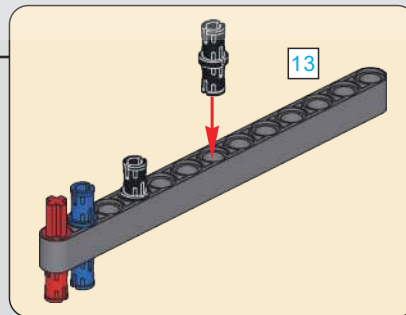
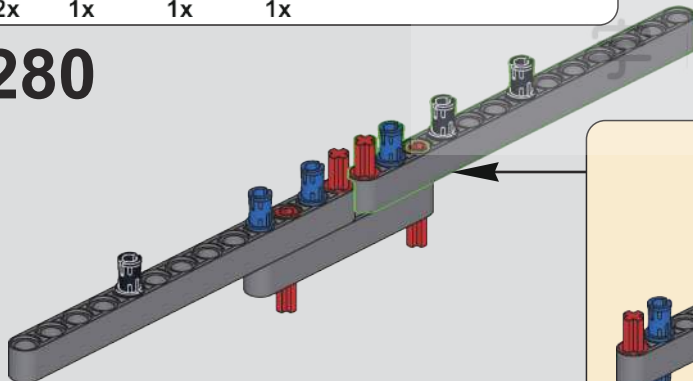



282

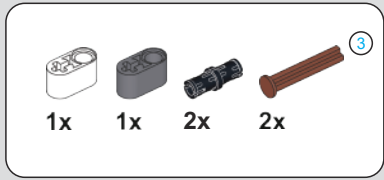
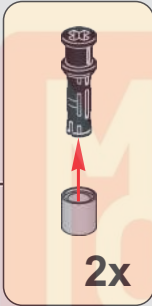
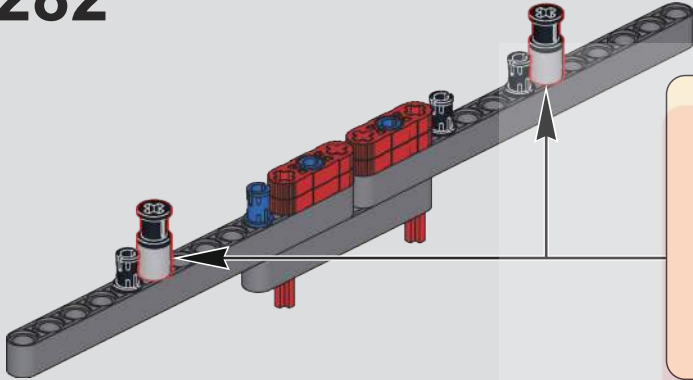

283

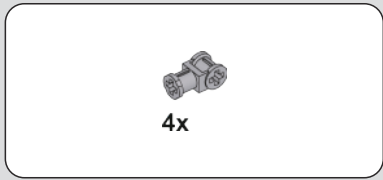
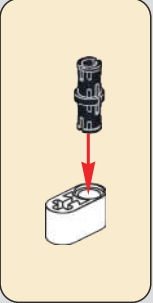
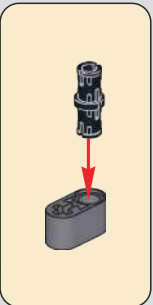
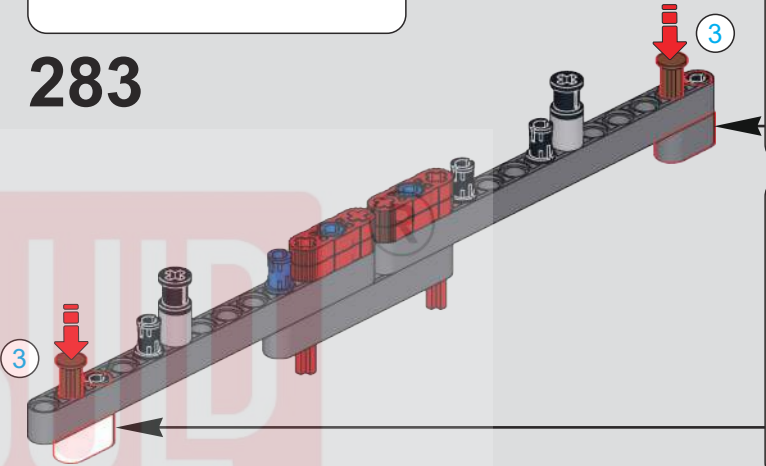

284

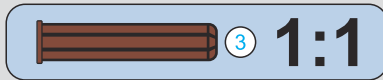
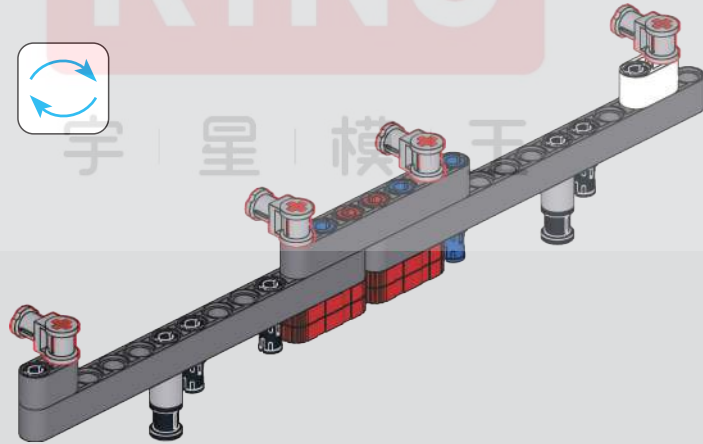

MOLD KING
宇 | 星 | 模 | 王

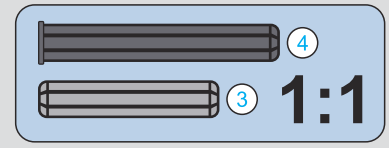
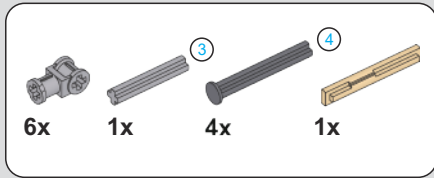

285

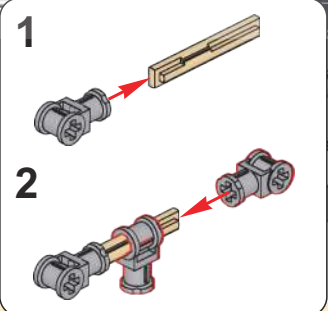
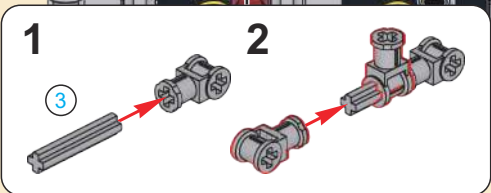
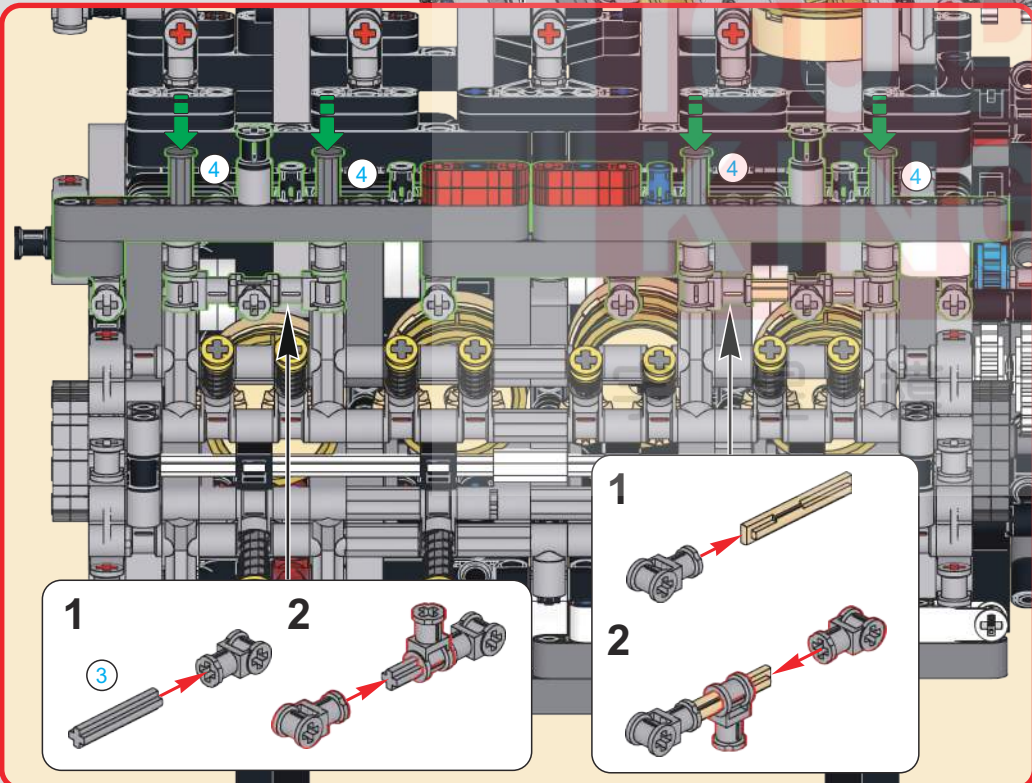
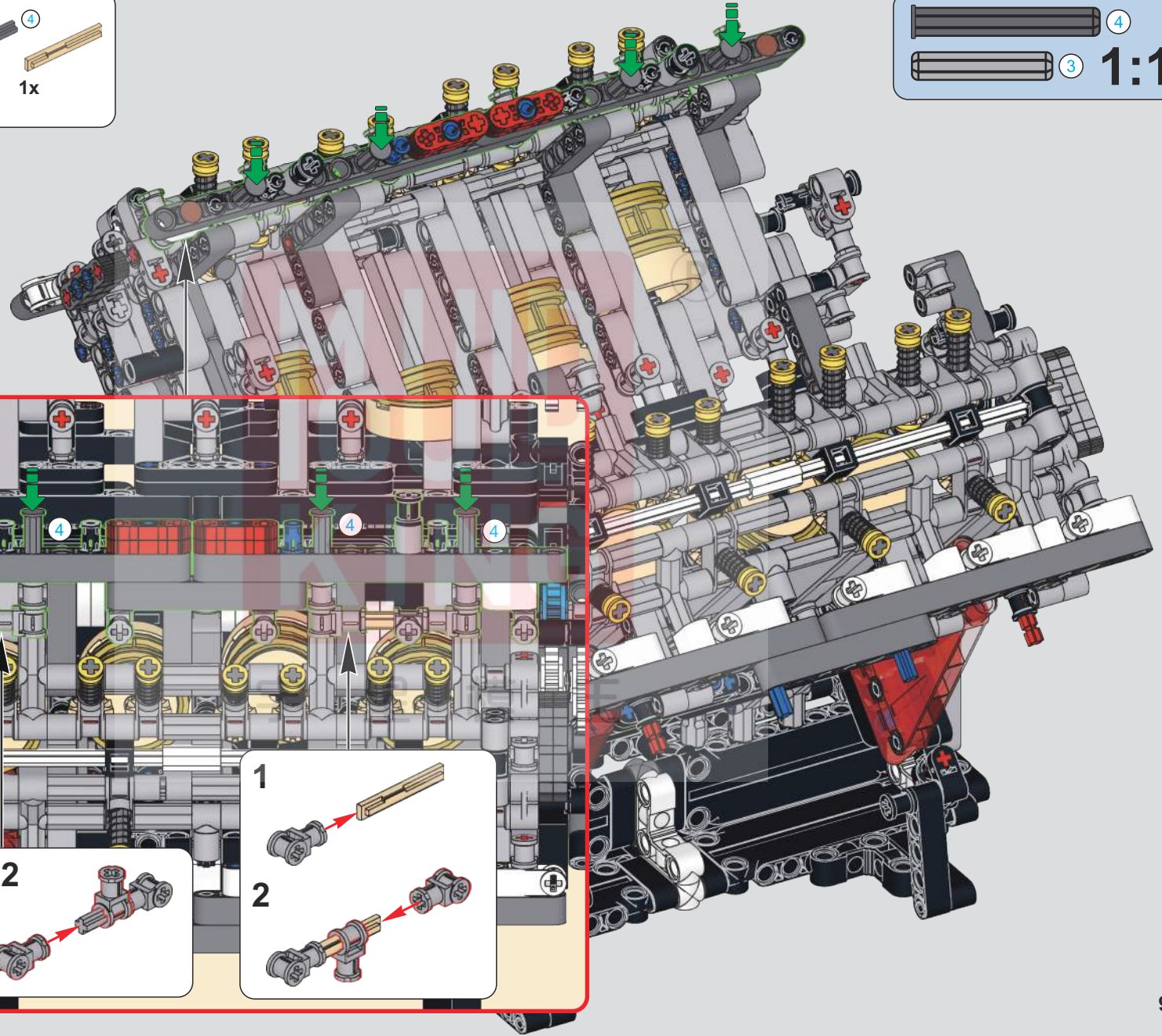

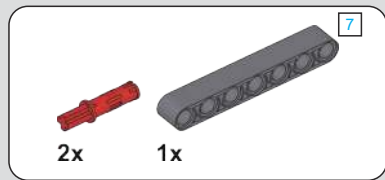
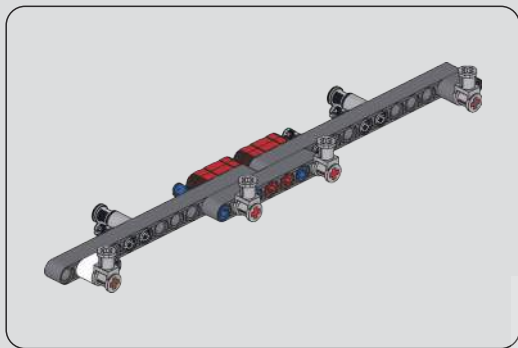

286

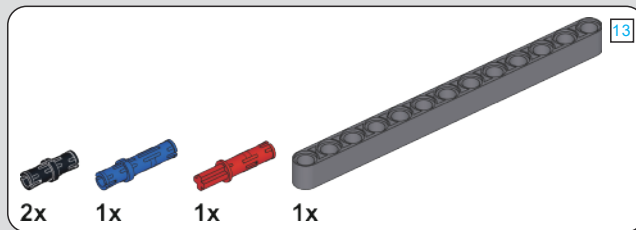

287

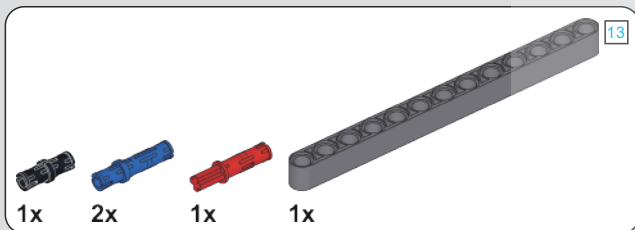
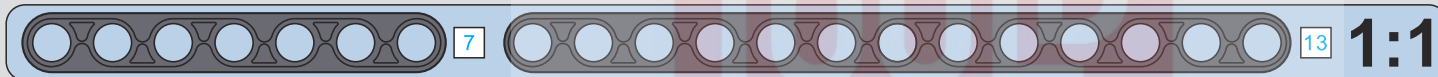
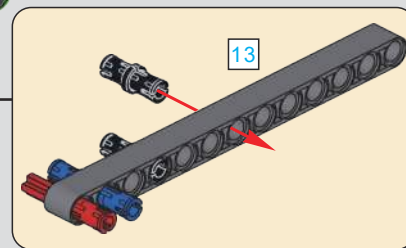
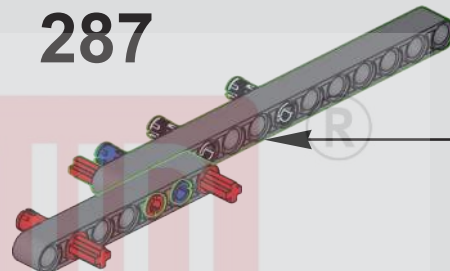
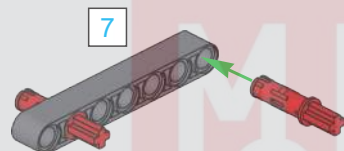

288

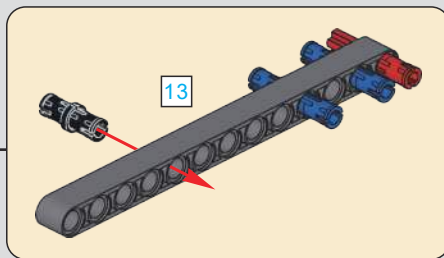
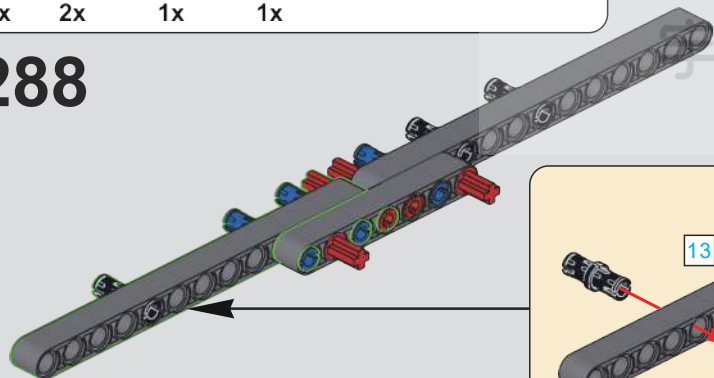

289

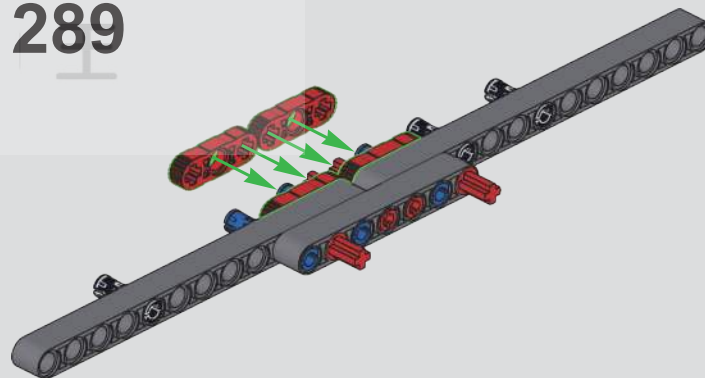



290

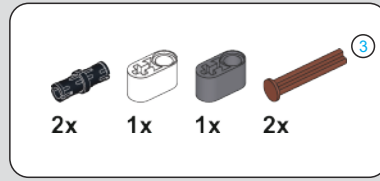
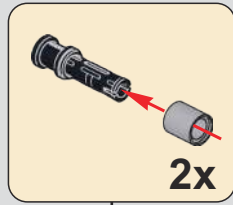
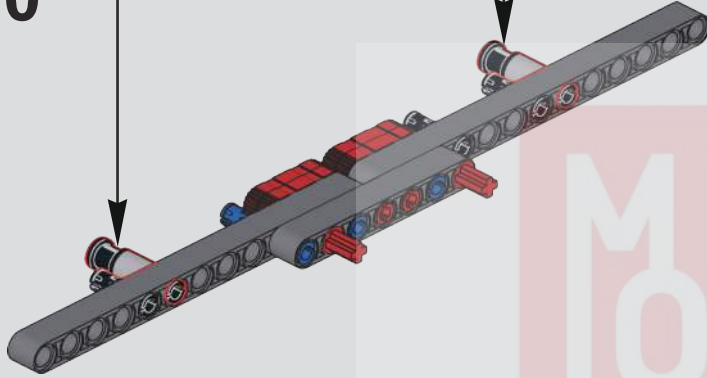

291

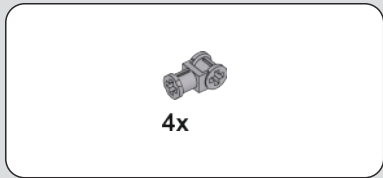
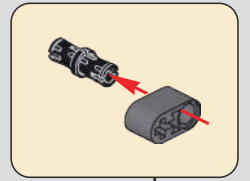
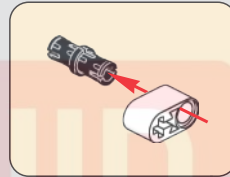

292

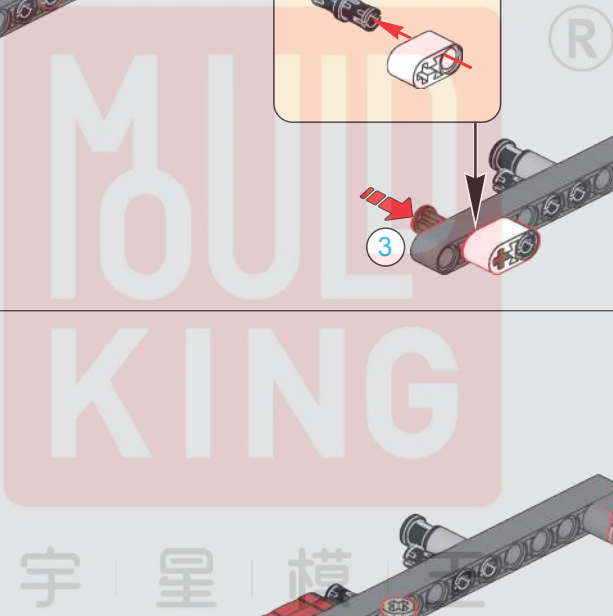
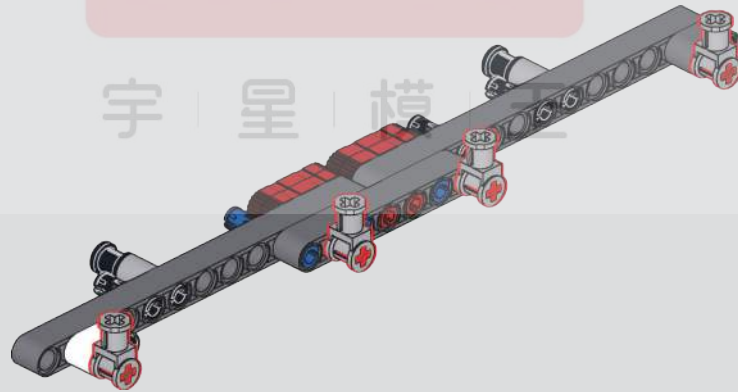

6x 1x 4x 1x

293

4 3 1:1

1 3

2

1

2

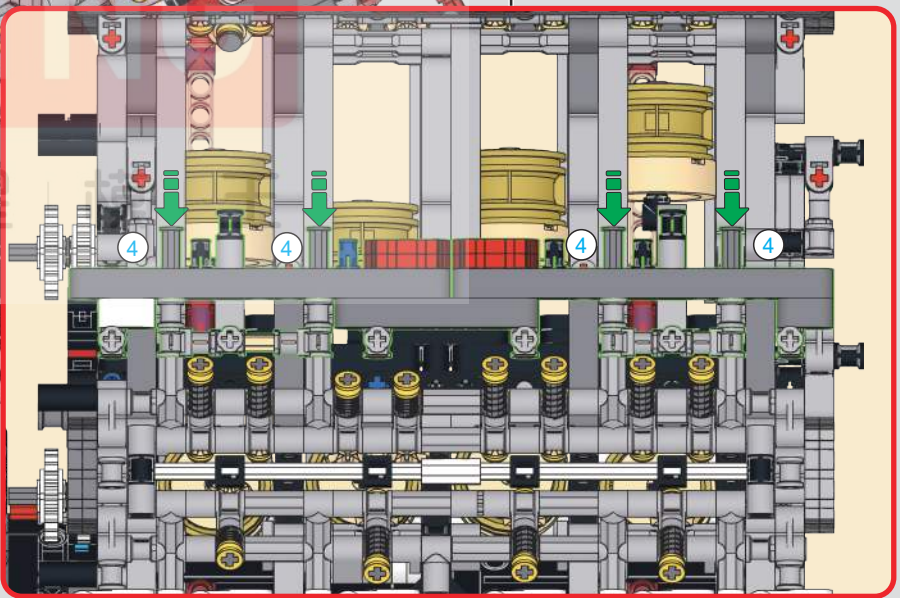
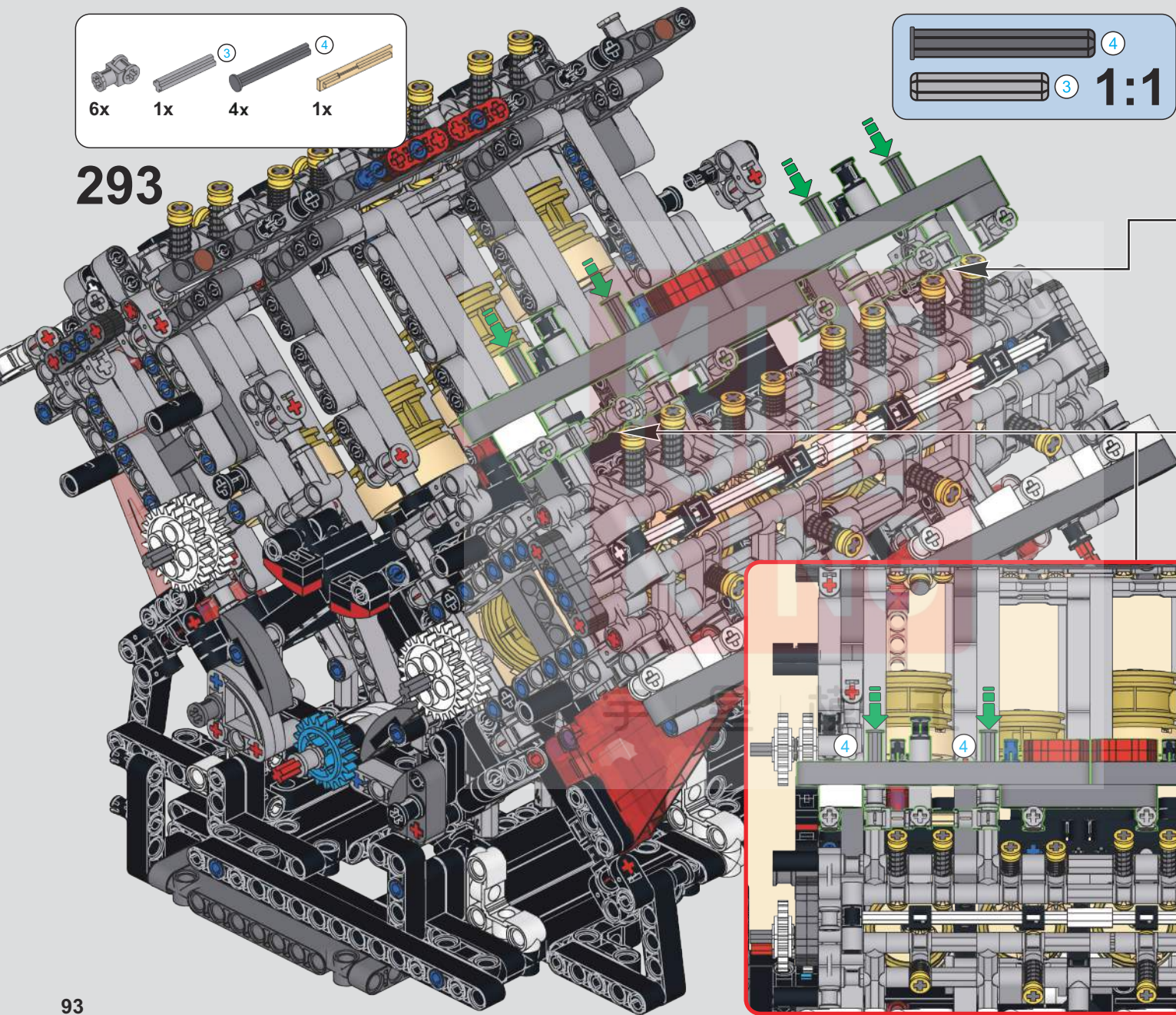

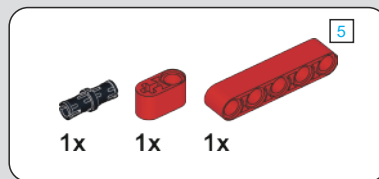
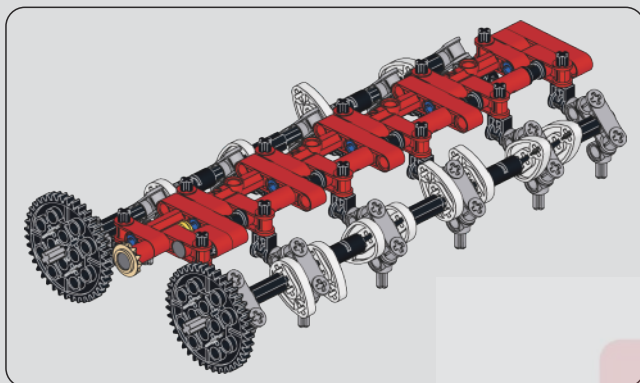

294



295

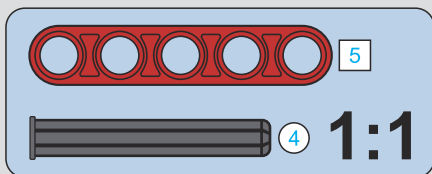

296

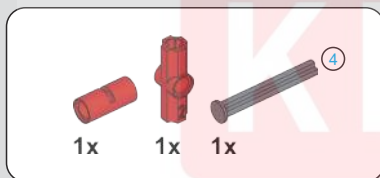

297

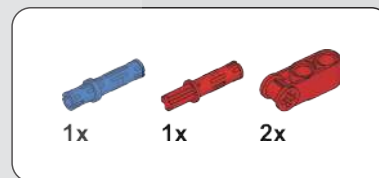
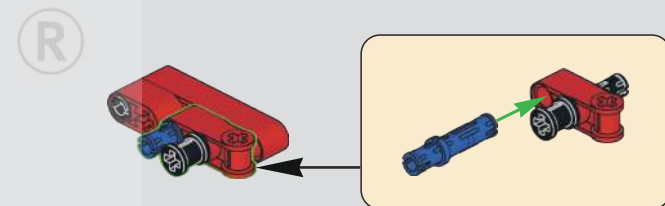

298

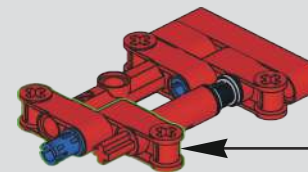
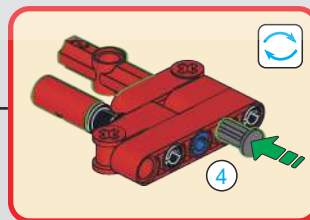
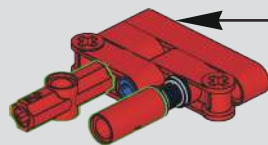
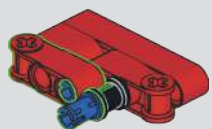
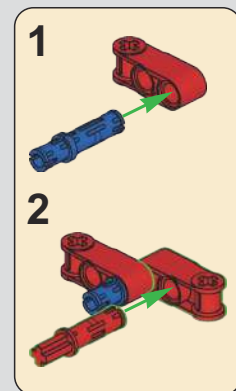

MOLD KING
宇 | 星 | 模 | 王

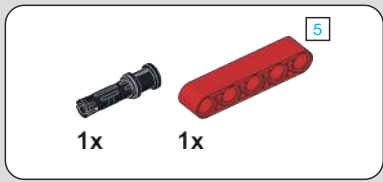

299

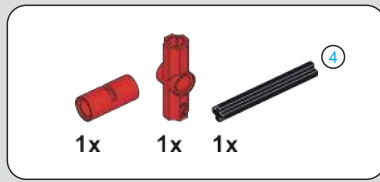
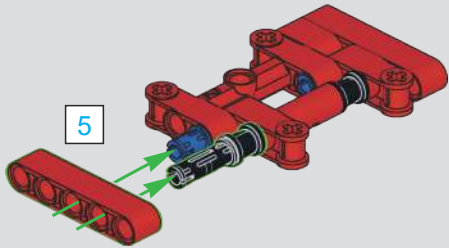

300

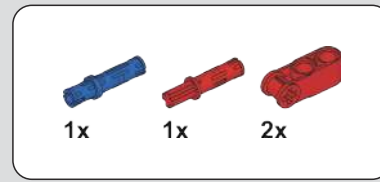
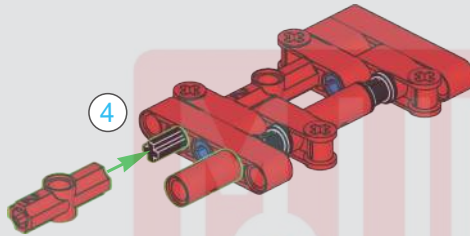

301

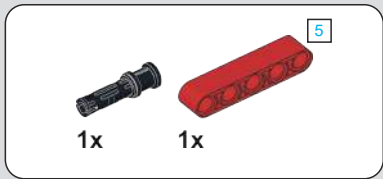
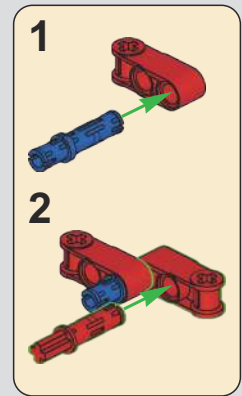
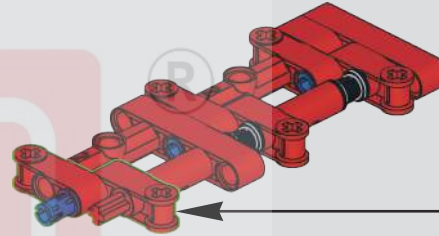

302

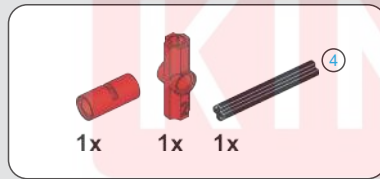
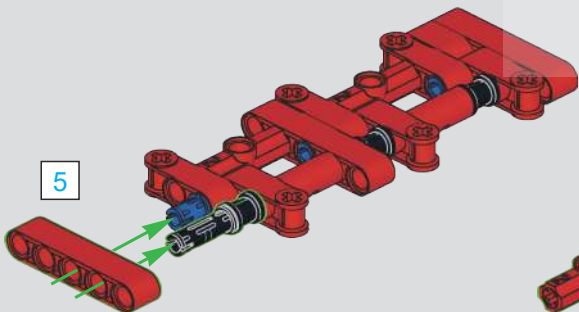

303

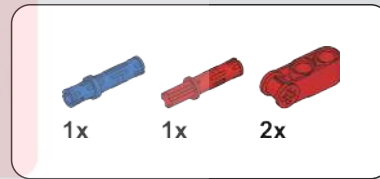
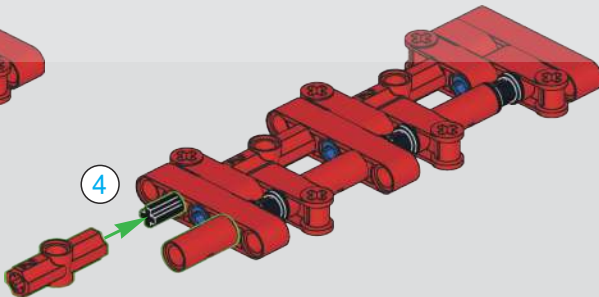

304

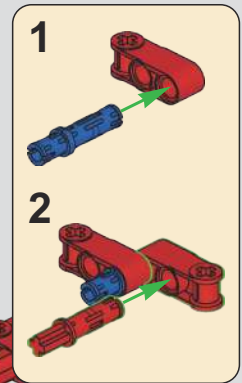
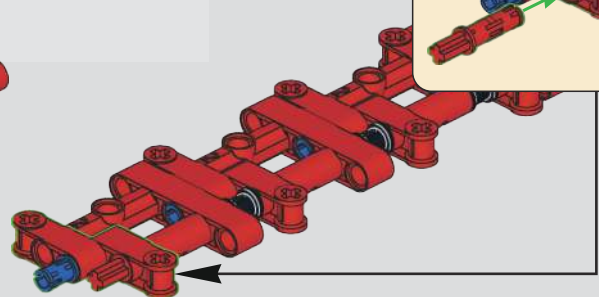



305

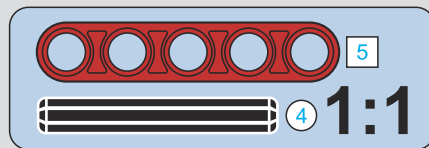
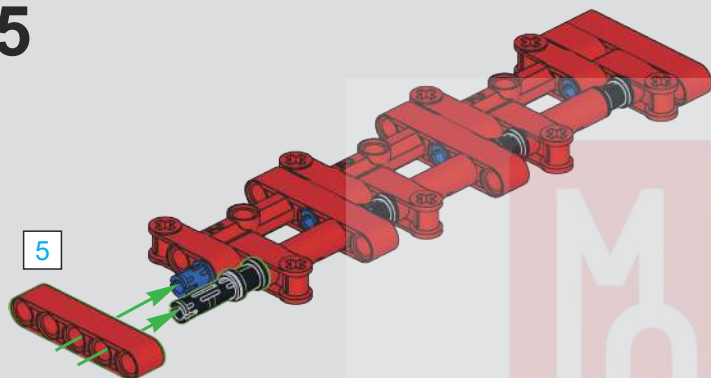

306

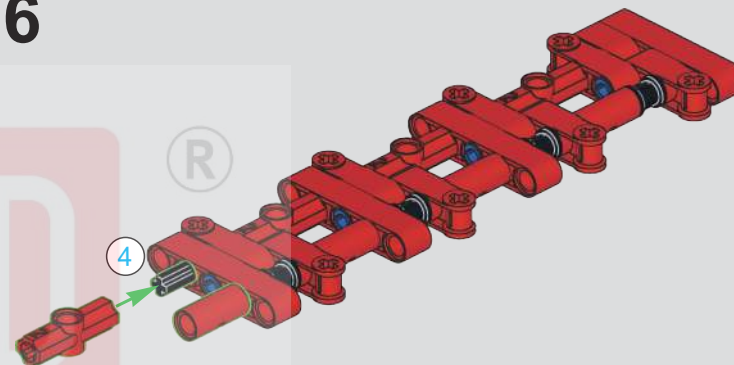
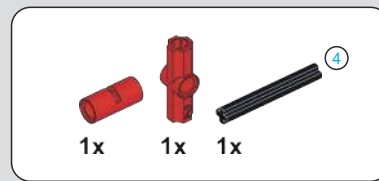

307

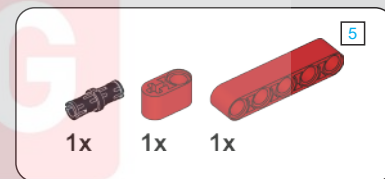
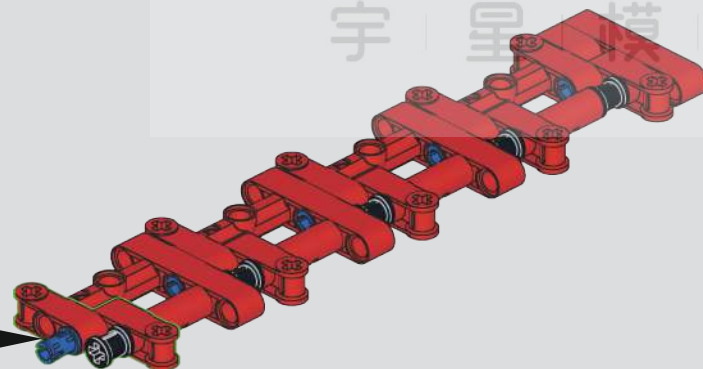
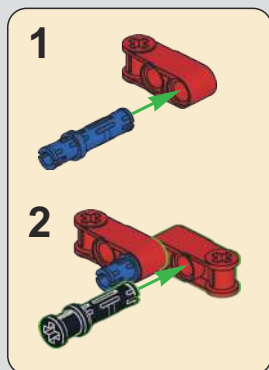

308

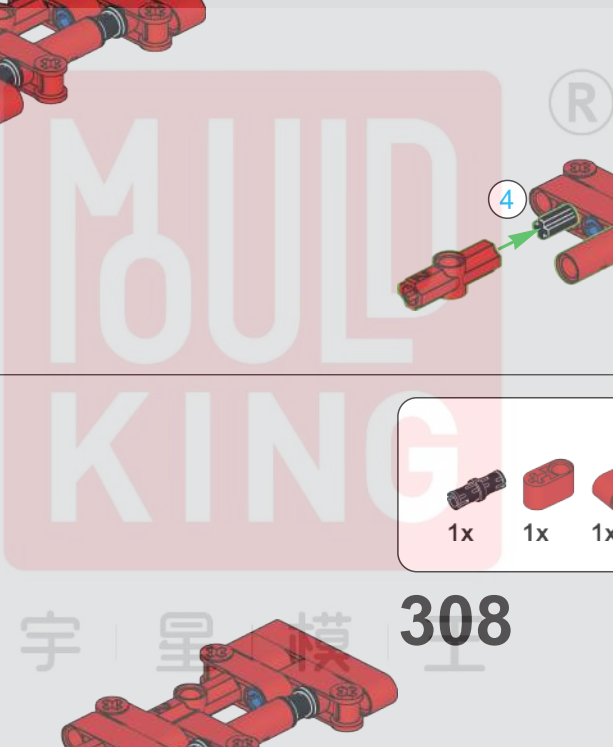
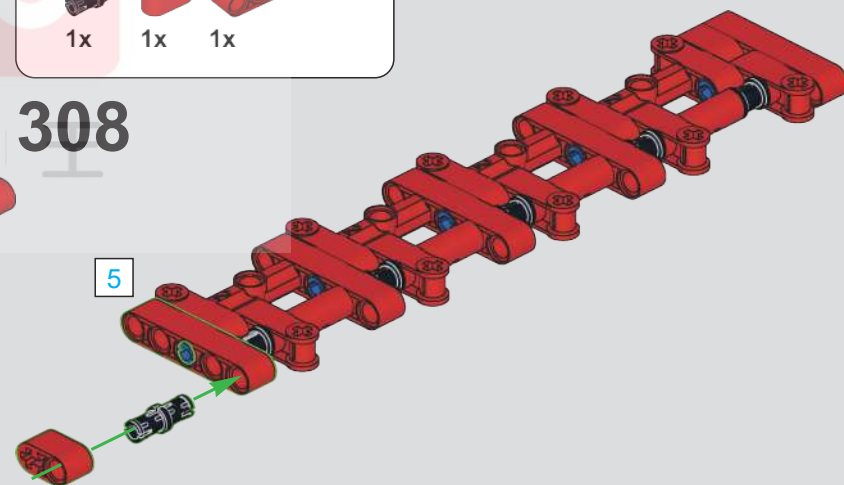

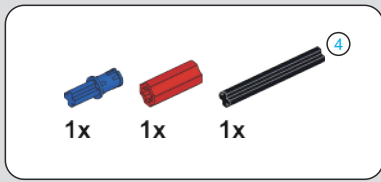

309

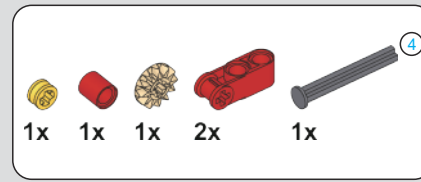
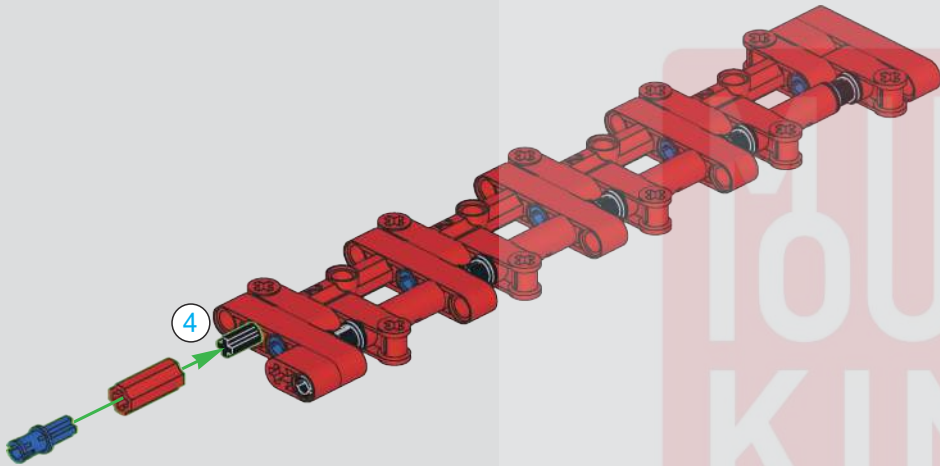

310

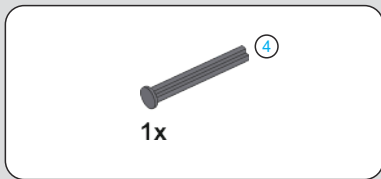
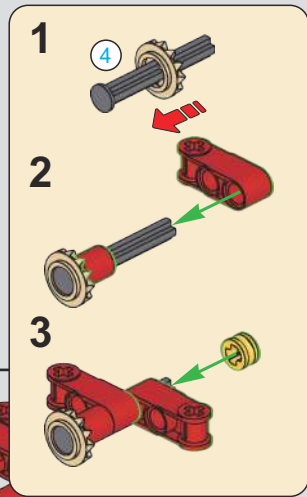
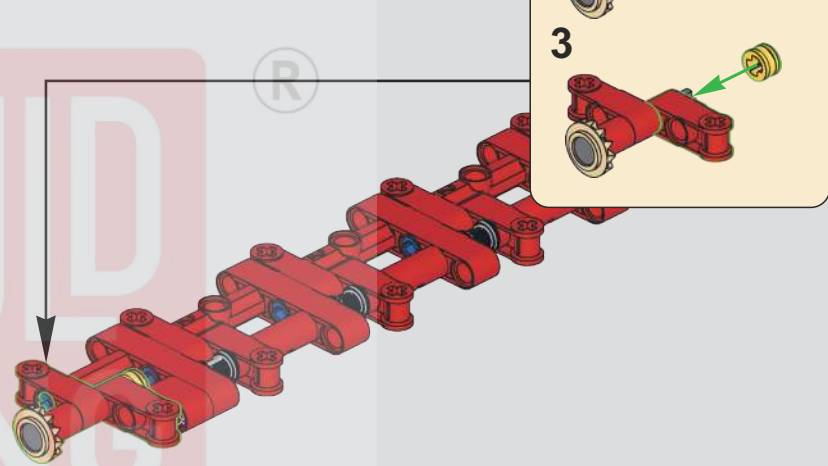

311

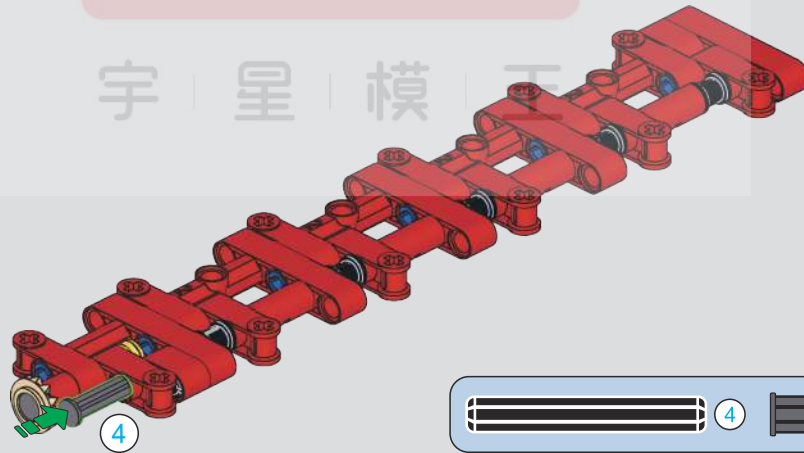



12x

312

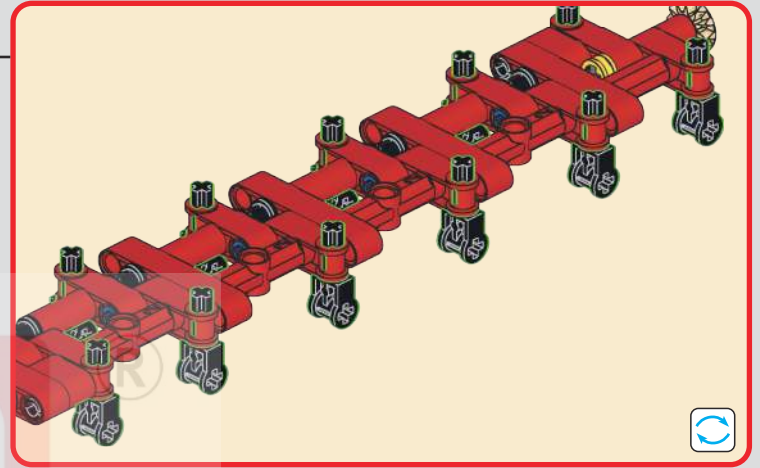
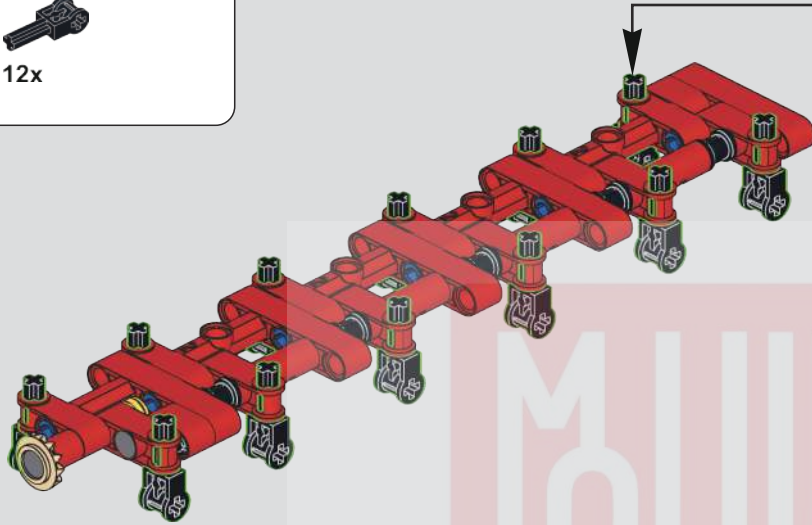

MOULD
KING

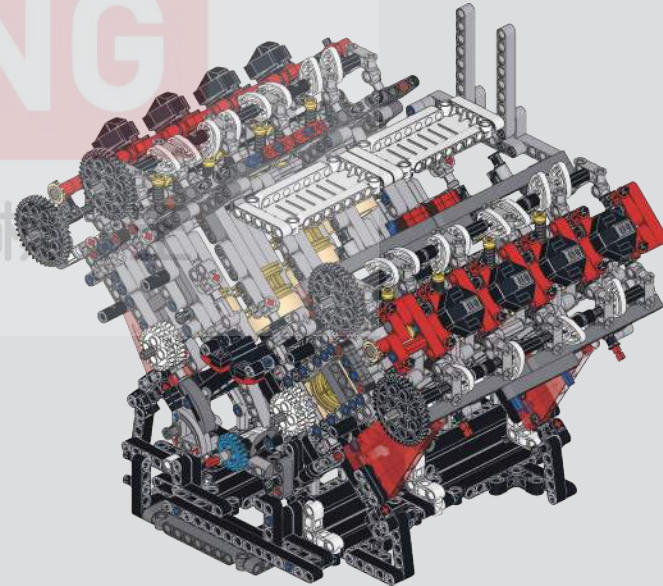

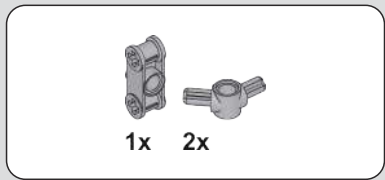
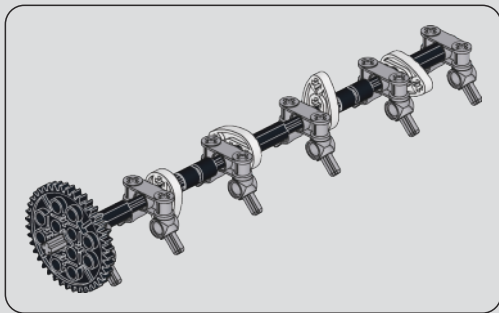

313

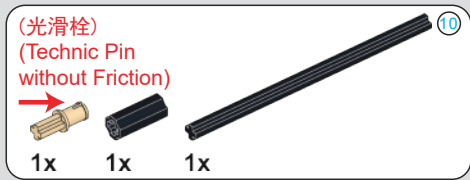

314

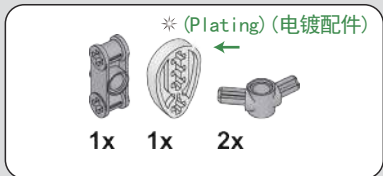
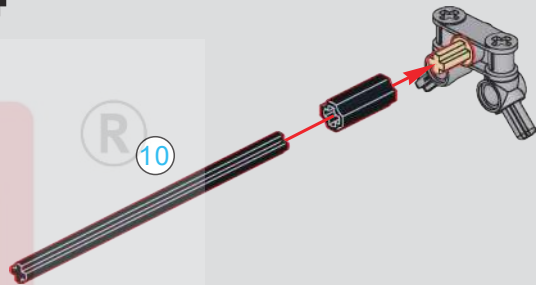
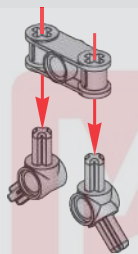

315

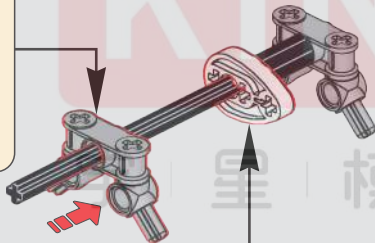
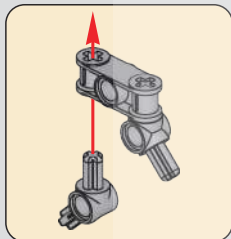

316

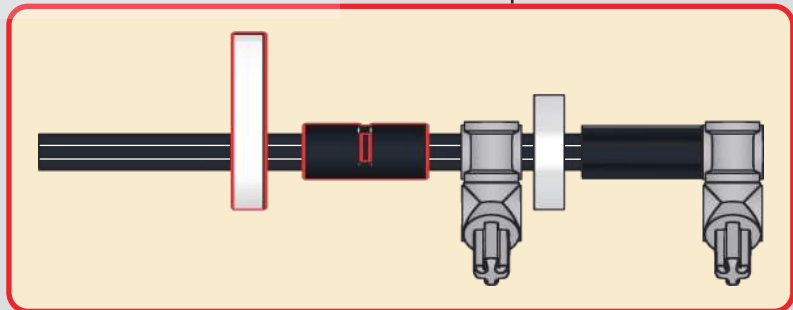
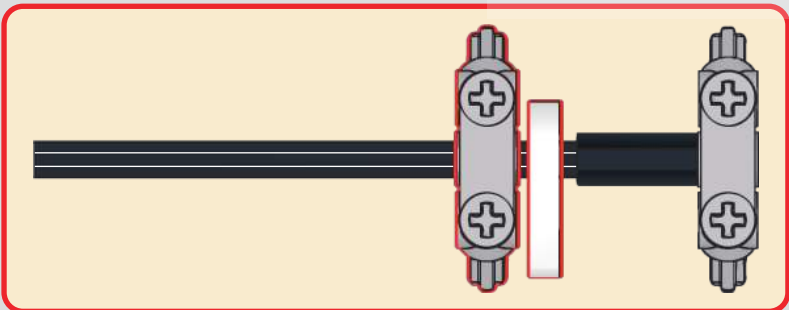
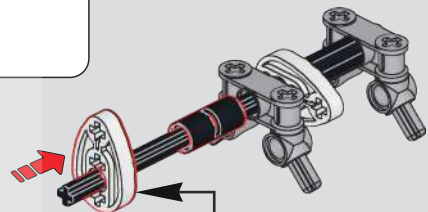

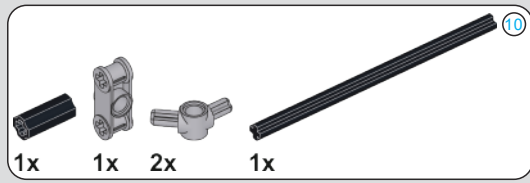

317

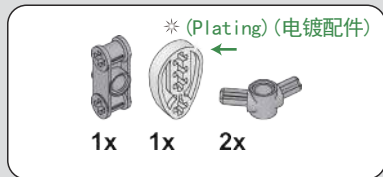
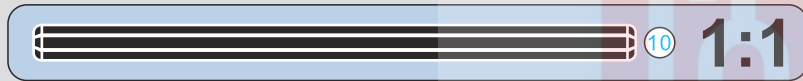
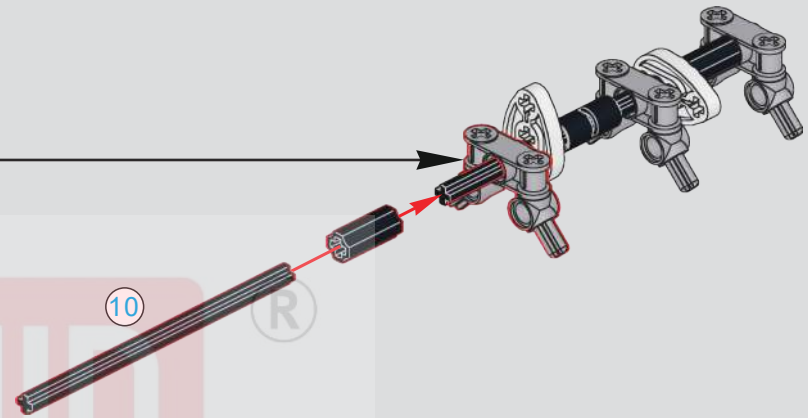
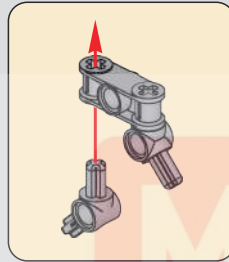

318

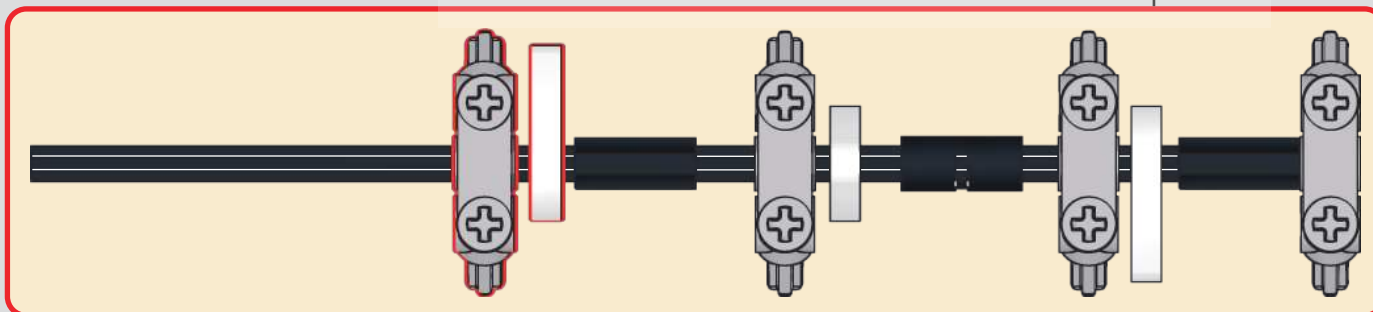
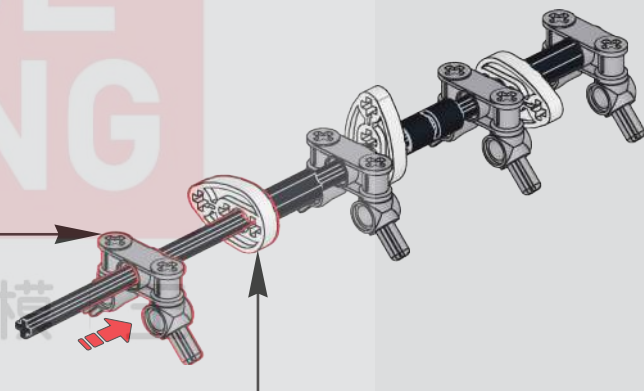
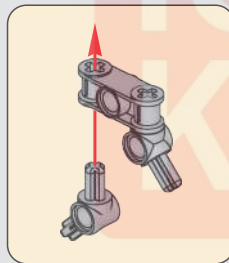

* (Plating) (电镀配件)



1x

1x

319

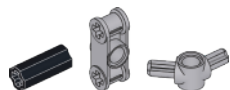
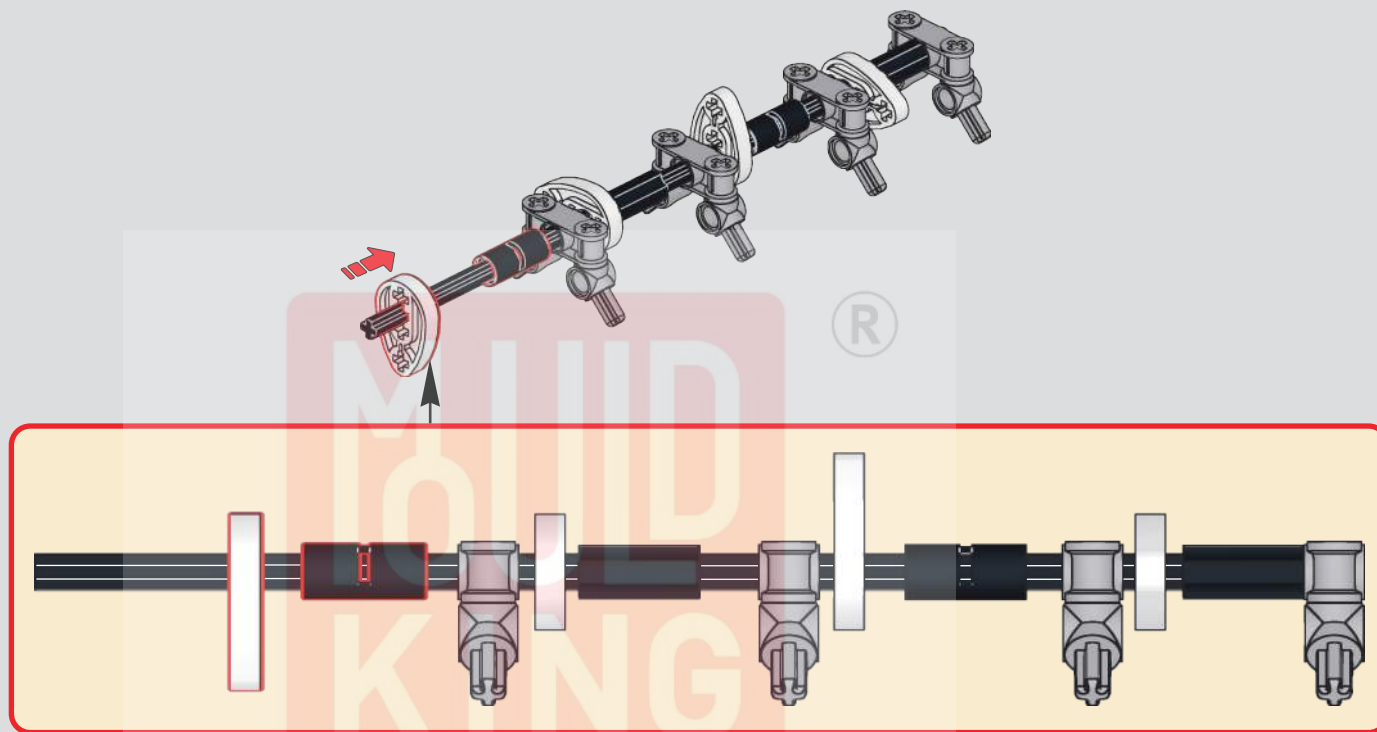

1x

1x

2x

320

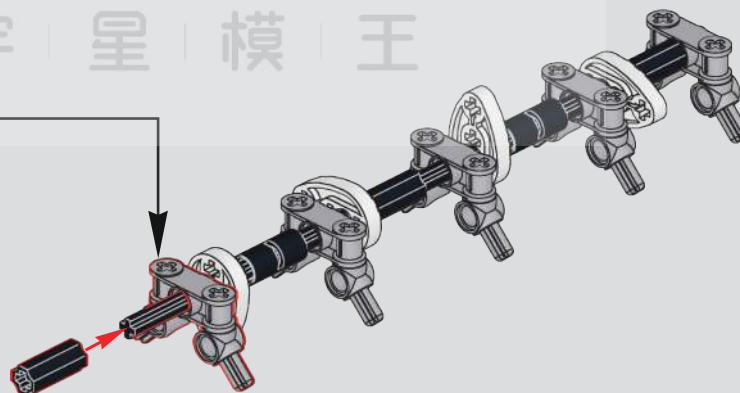
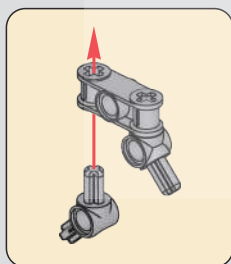

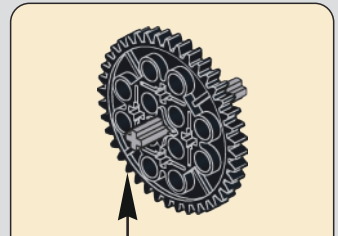
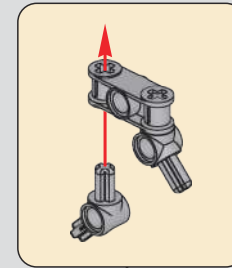
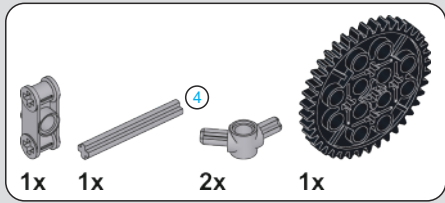

321

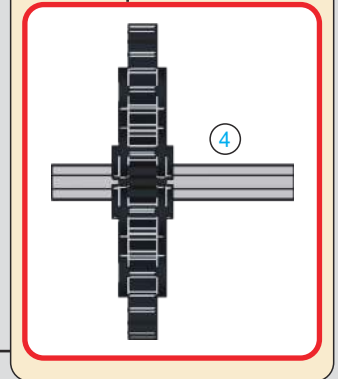
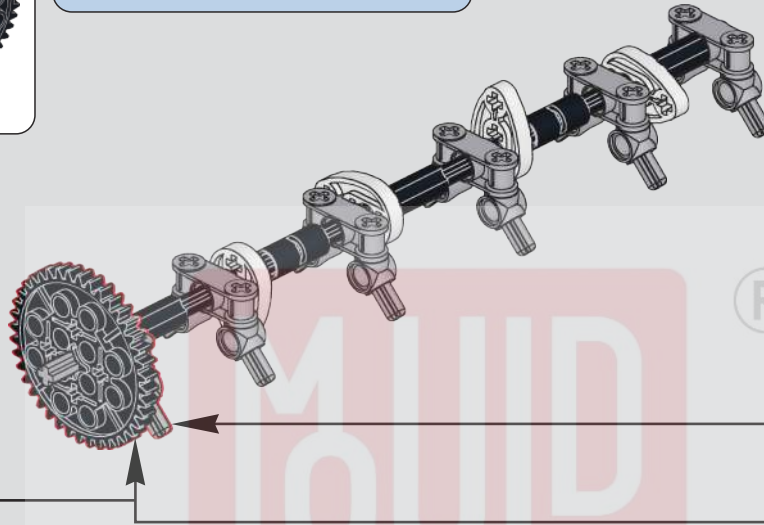
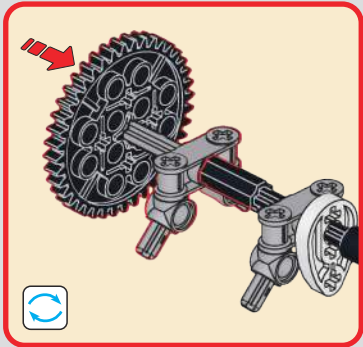

322

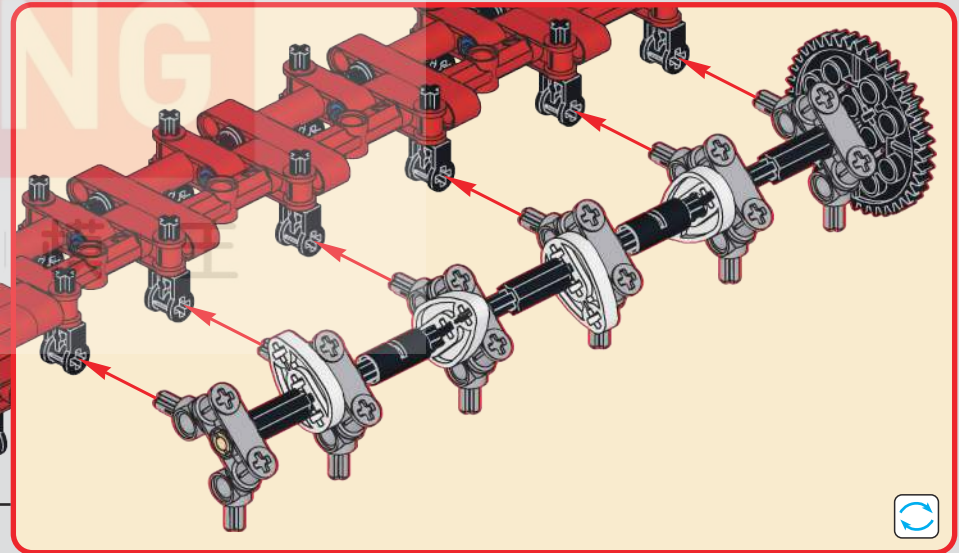
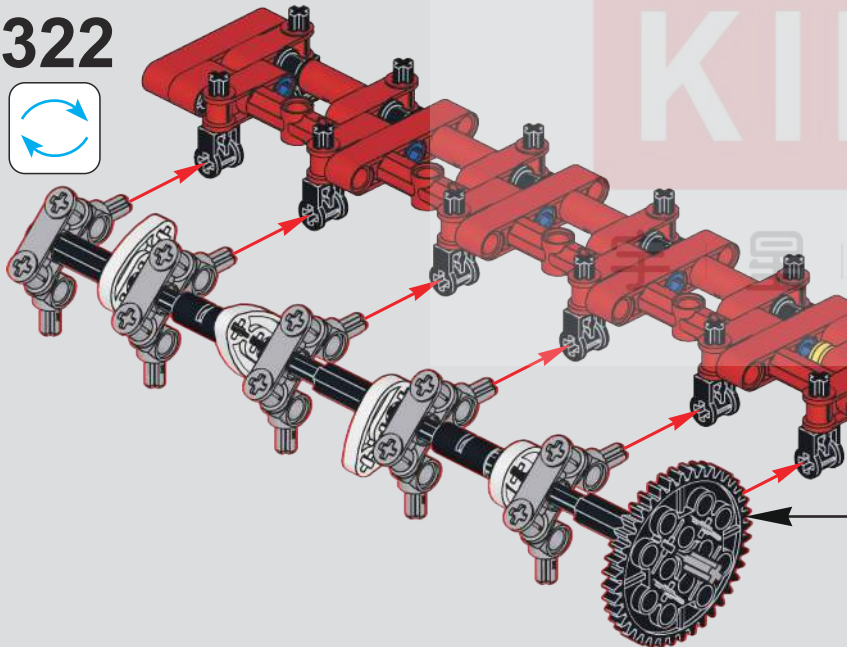

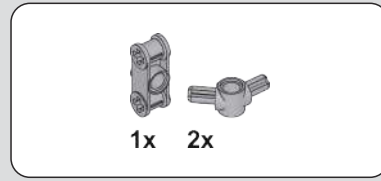
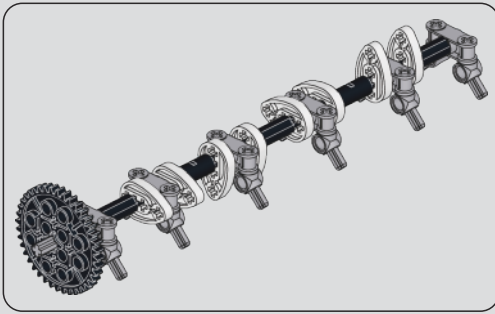

323

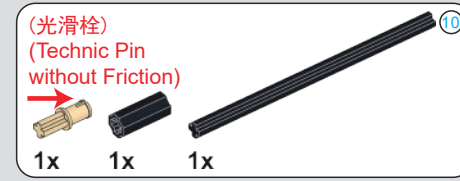

324

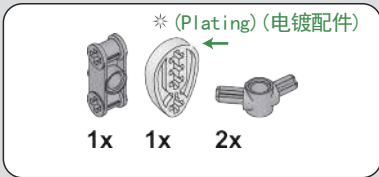
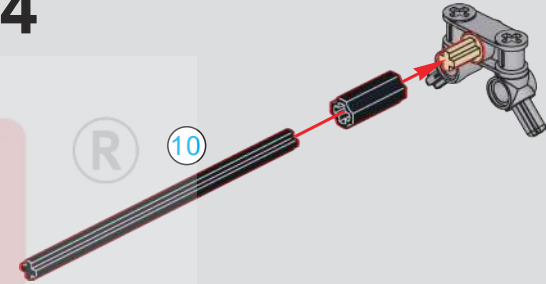
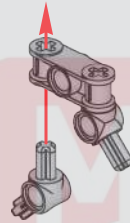

325

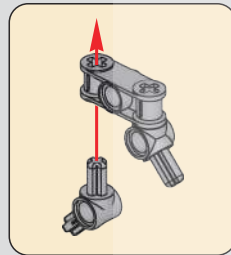

326

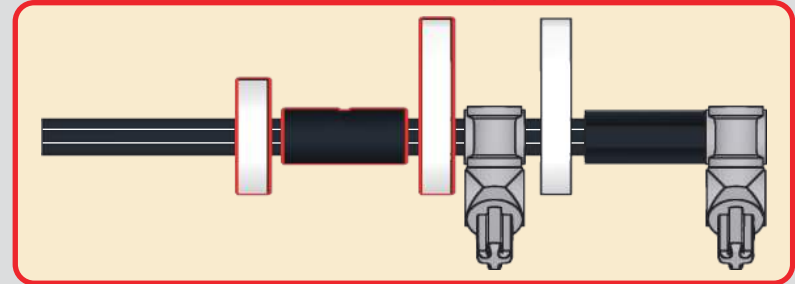
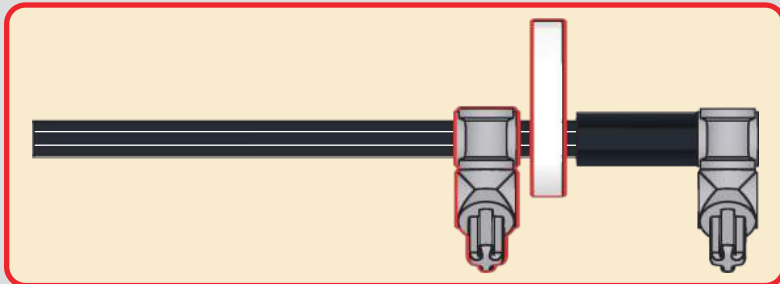
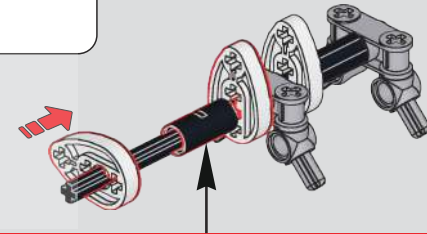
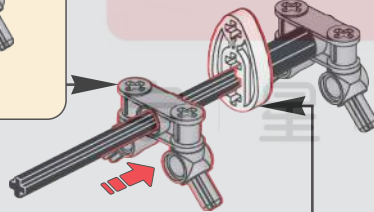

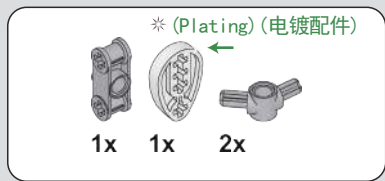

327

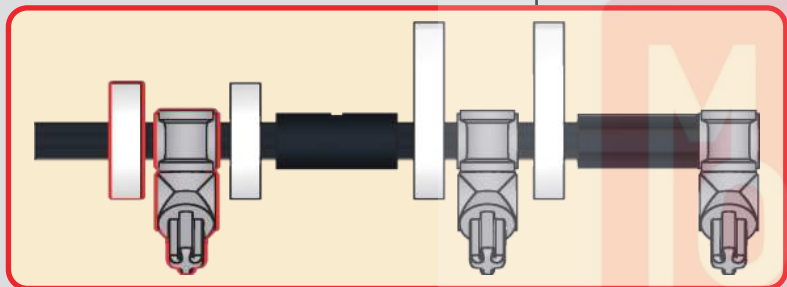

328

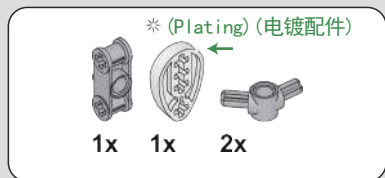
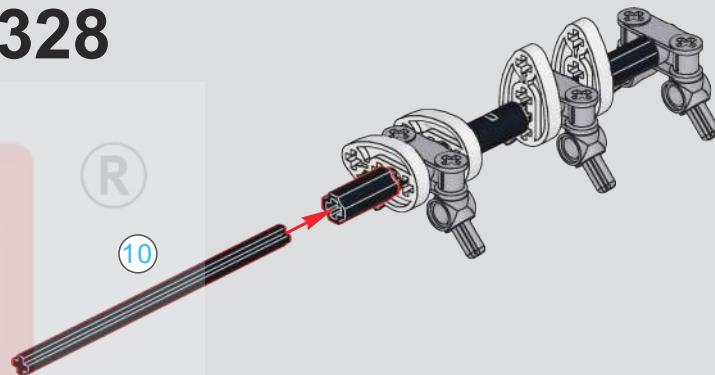
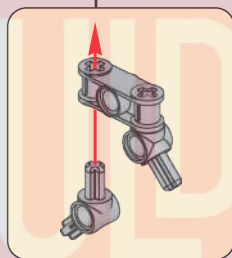

329

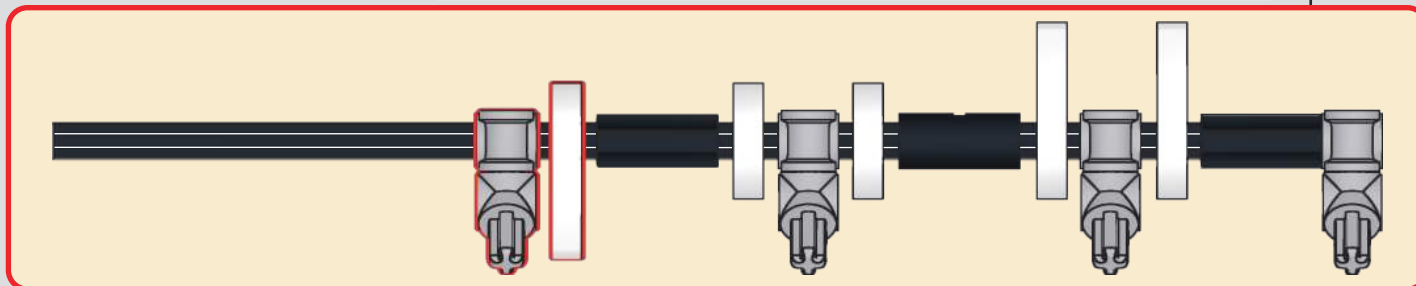
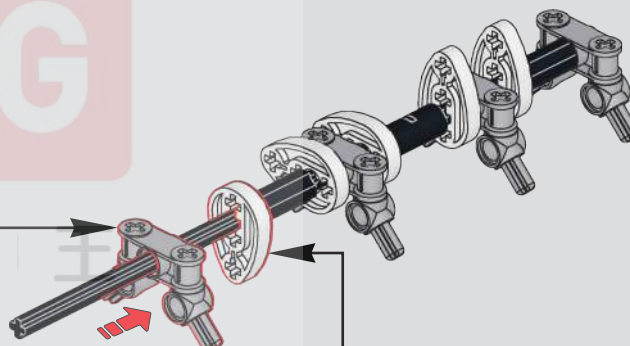
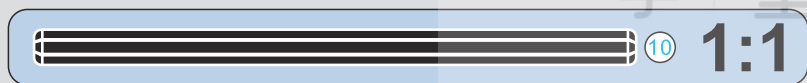
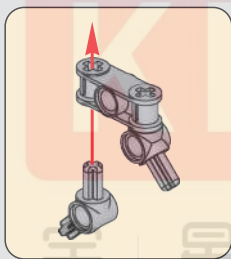



330

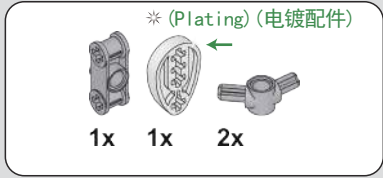
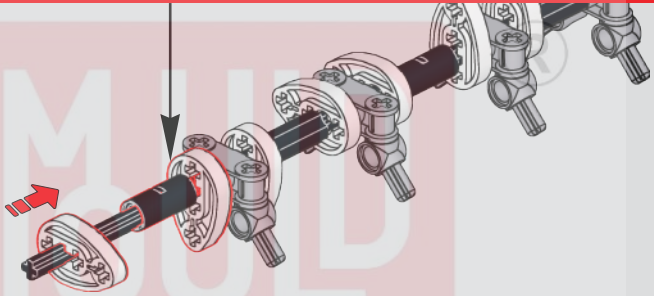
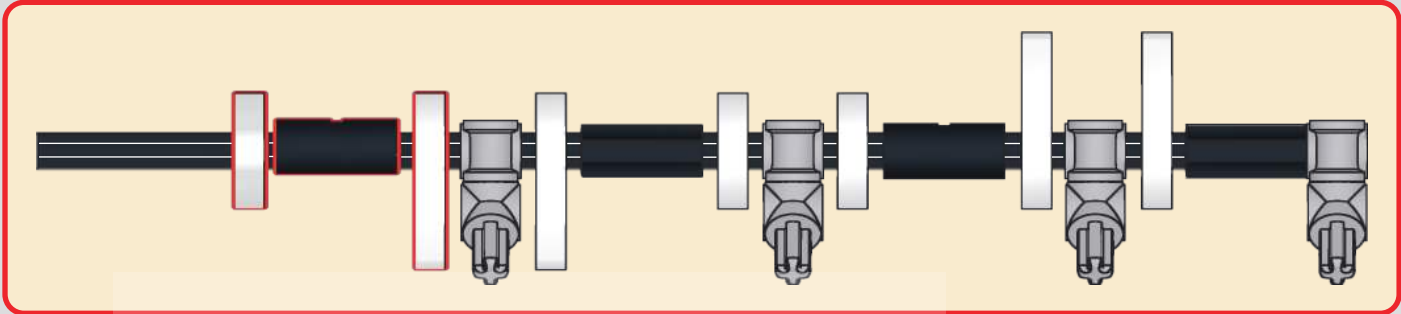

331

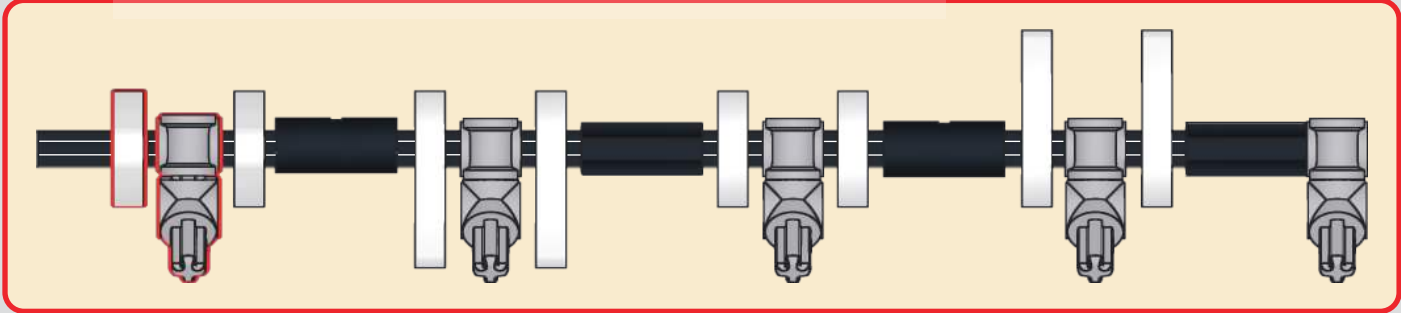
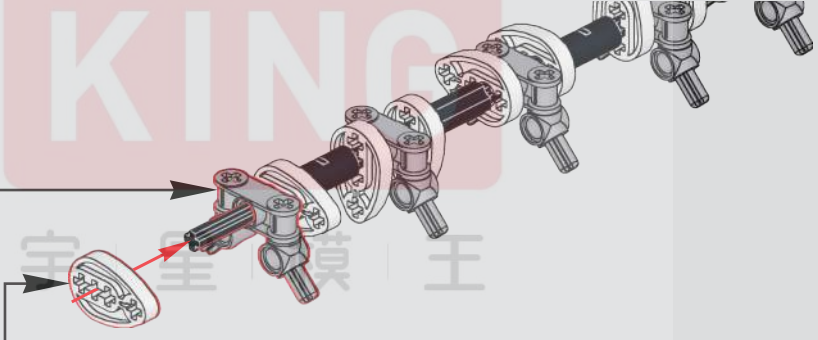
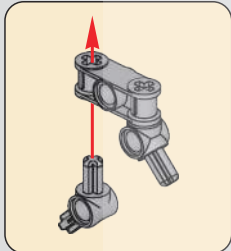

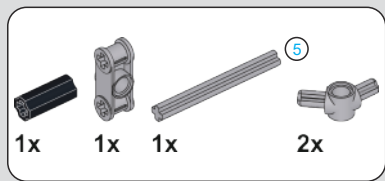

332

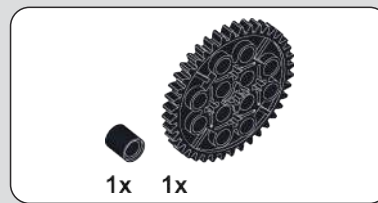
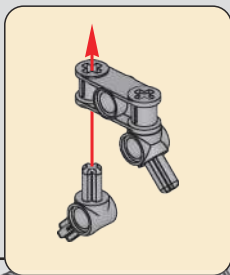

333

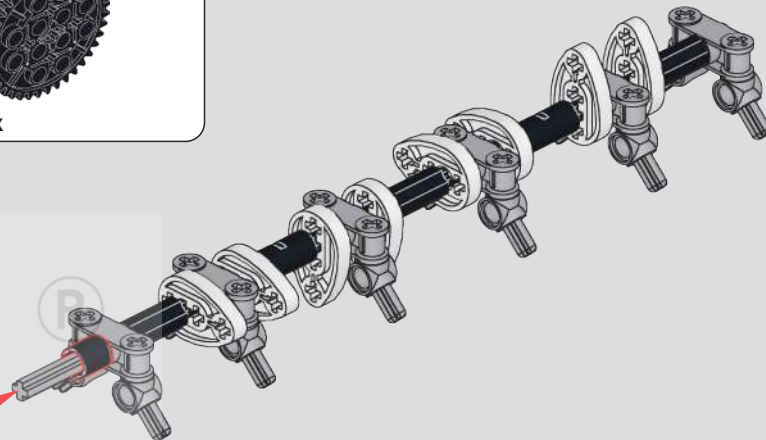
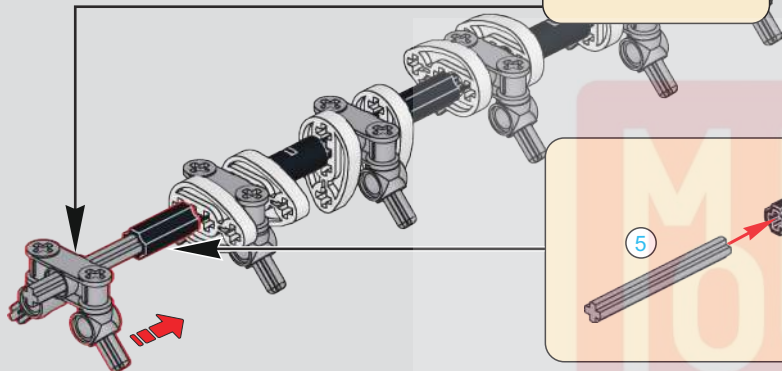
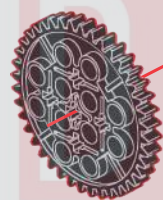
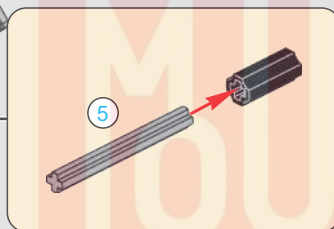

334

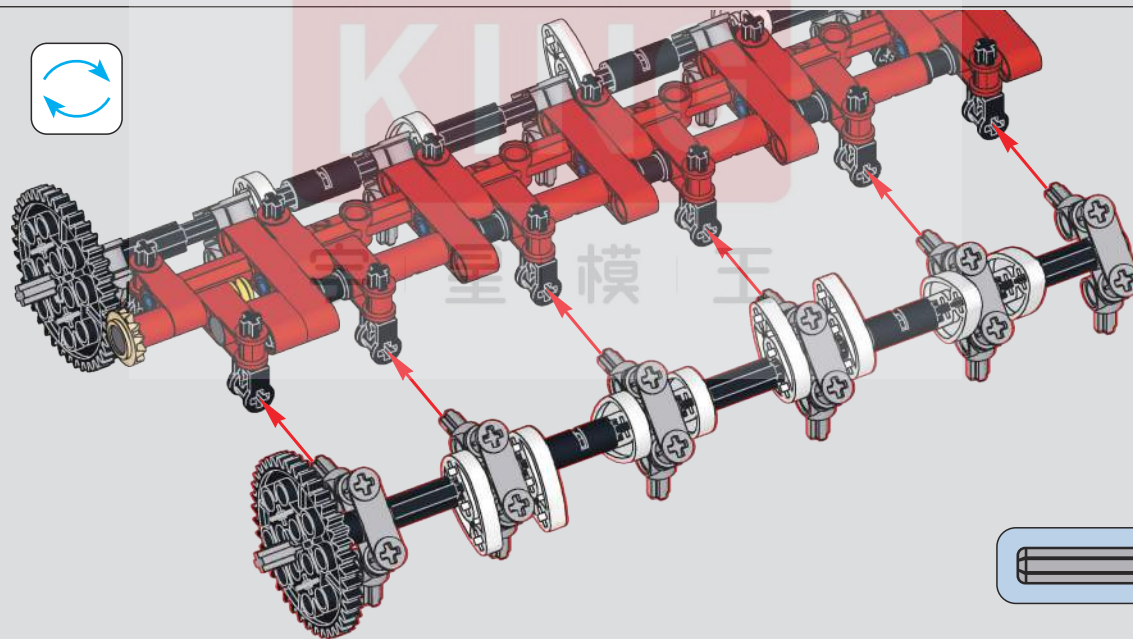

335

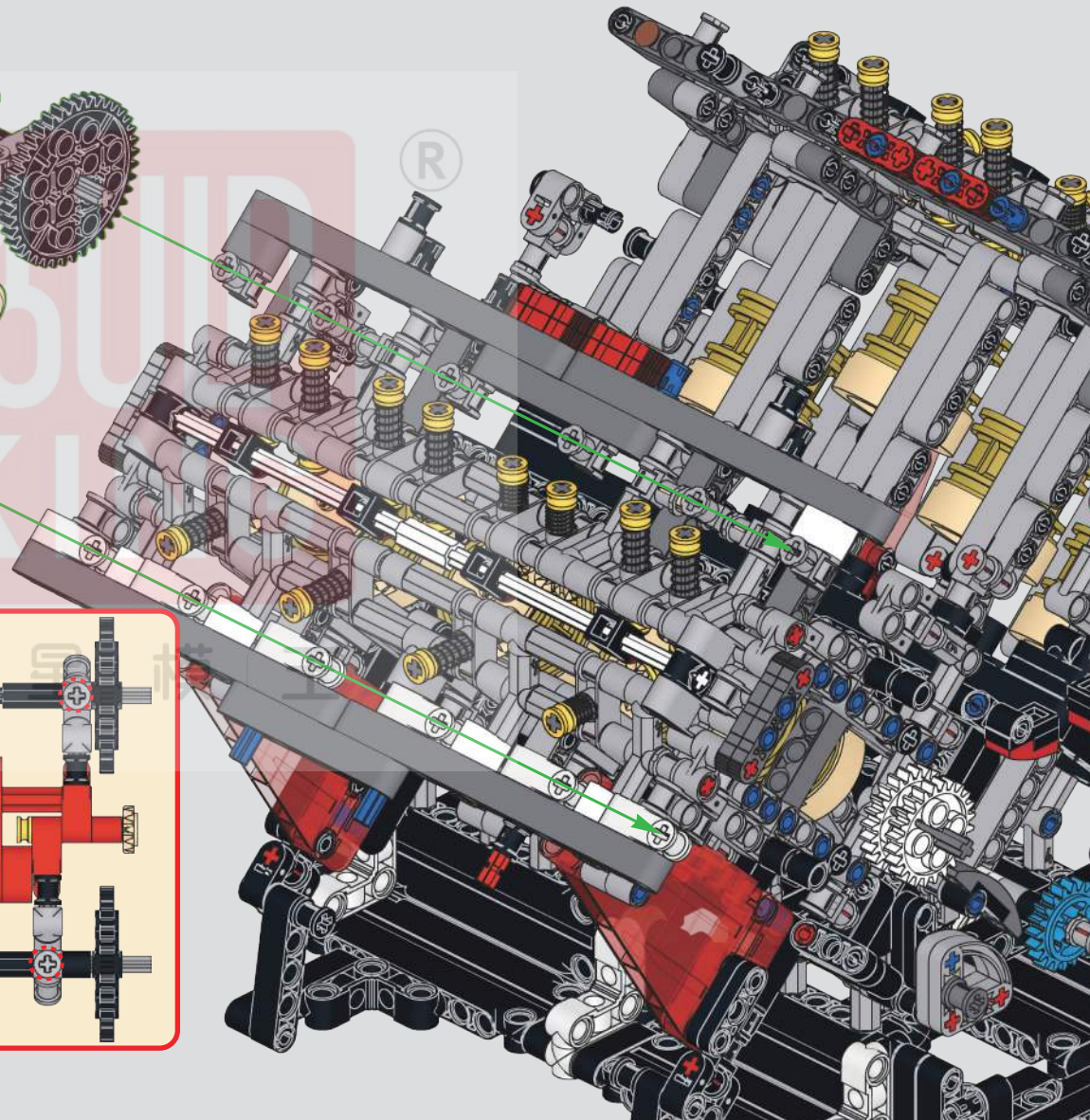
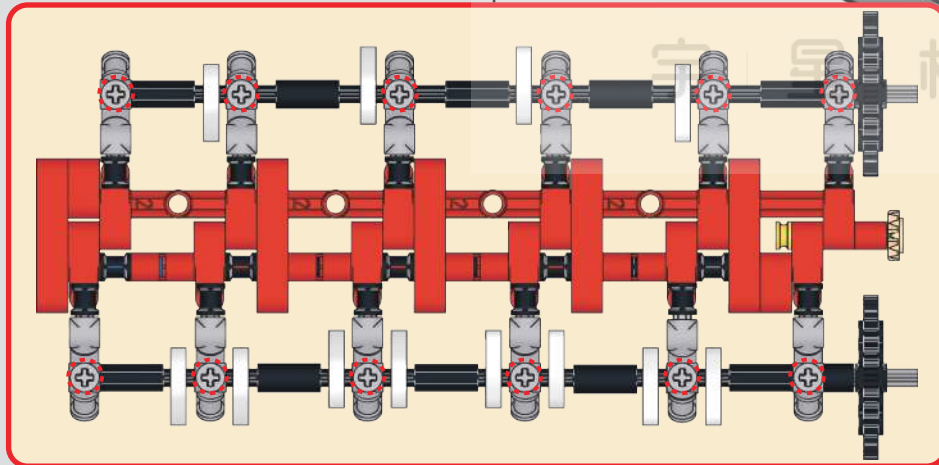
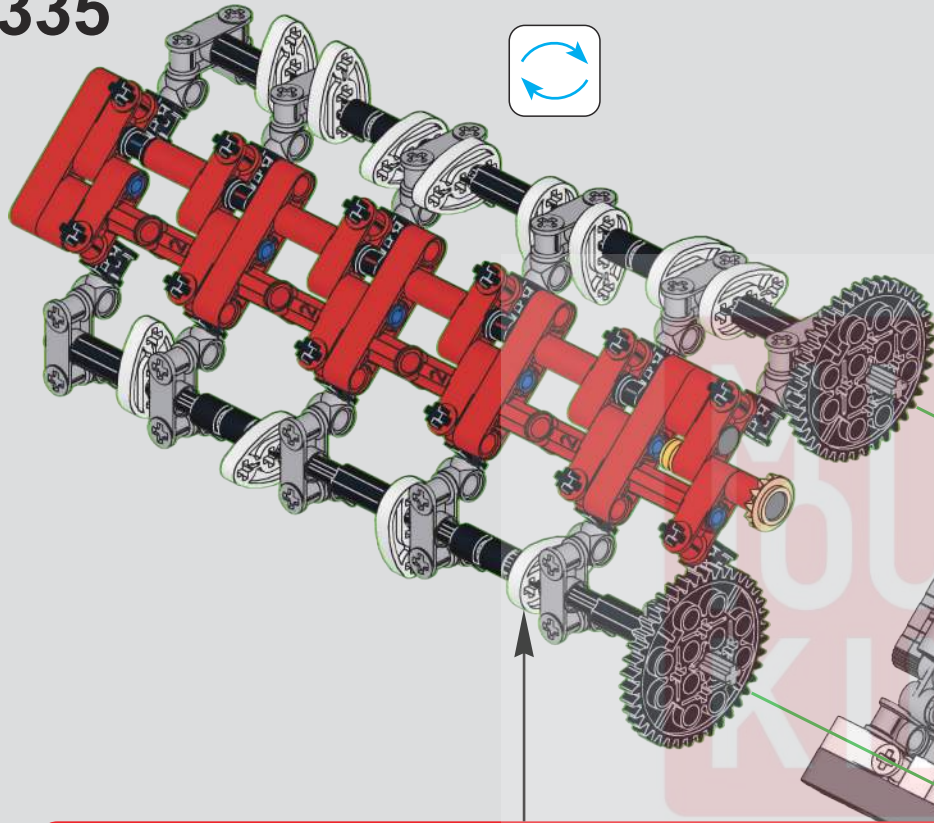

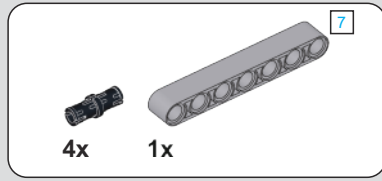
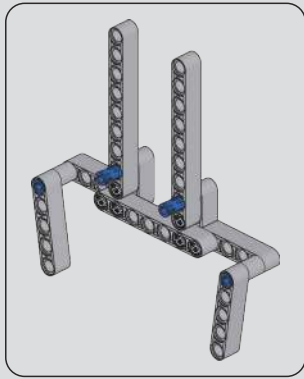

336

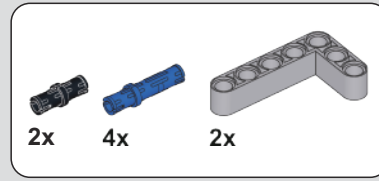
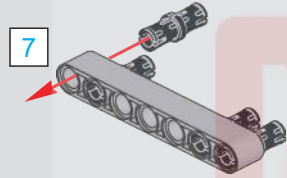

337

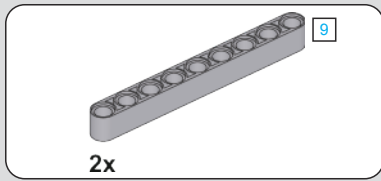
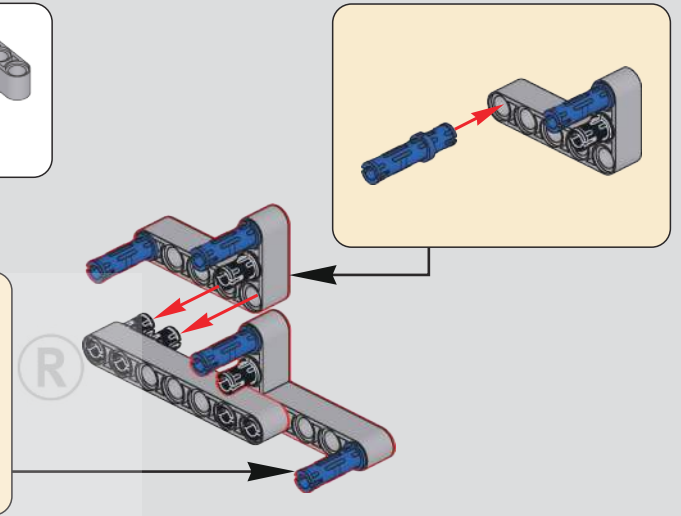
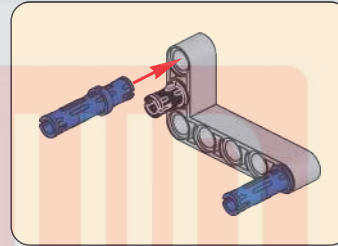

338

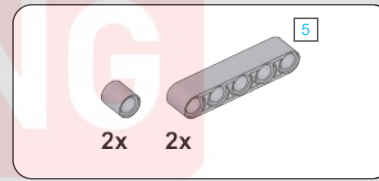
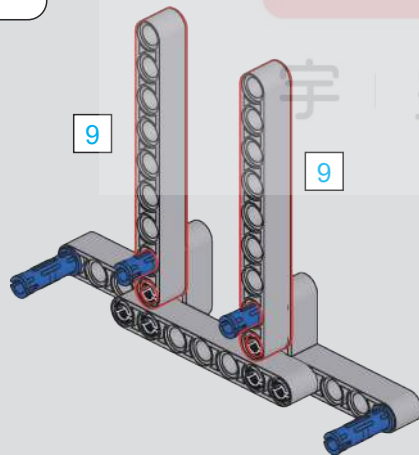

339

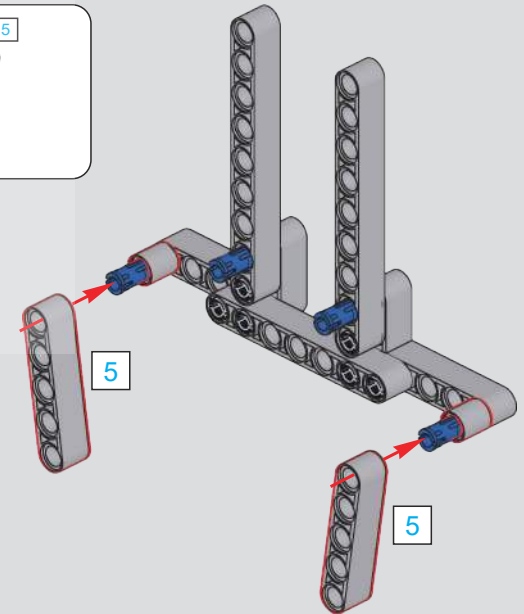

340

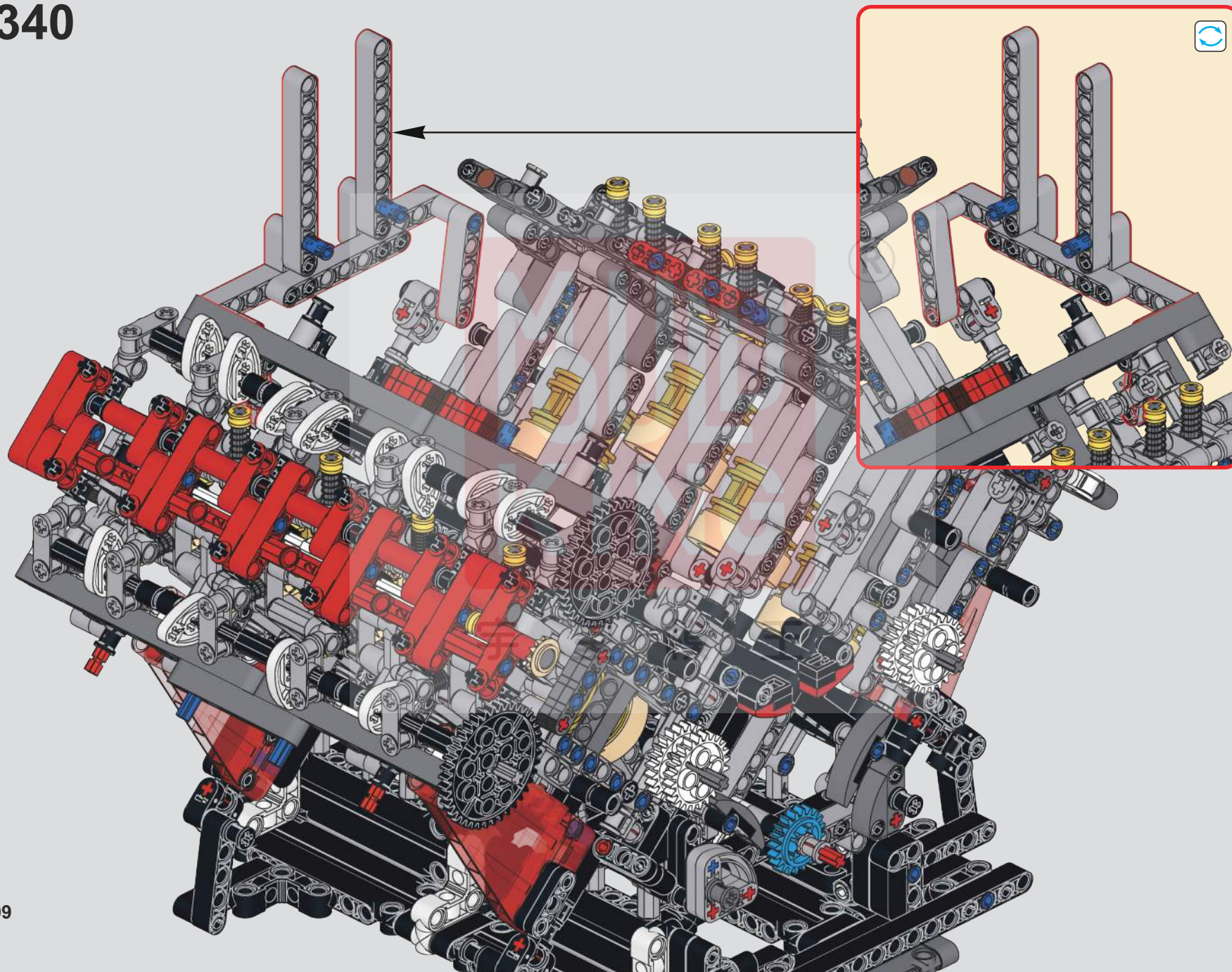

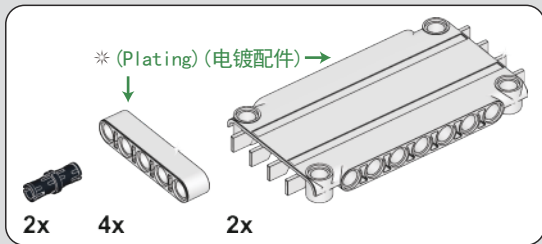

341

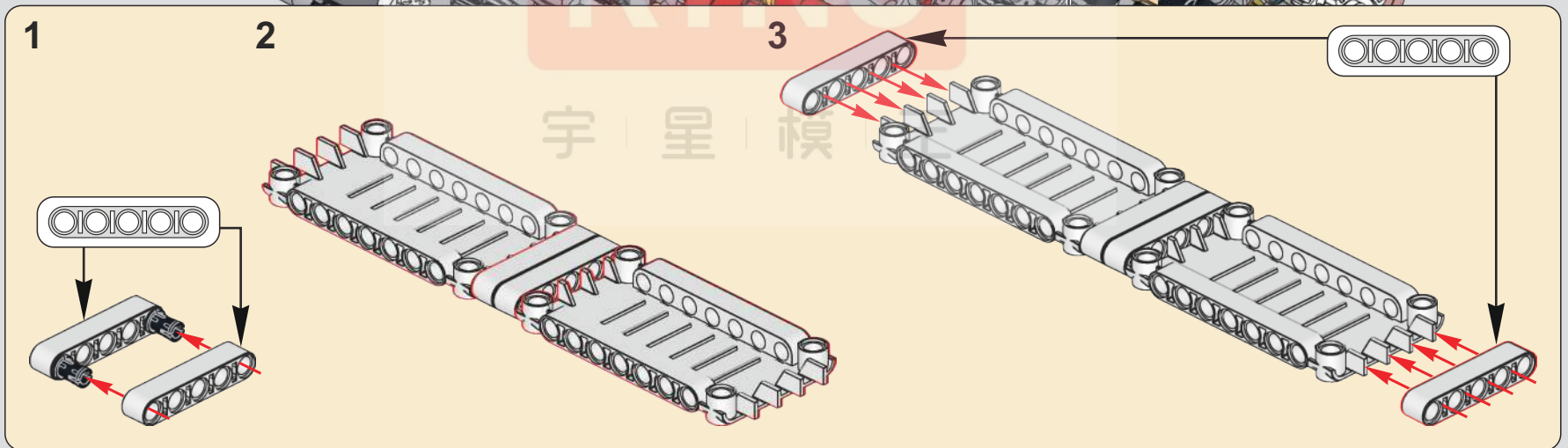
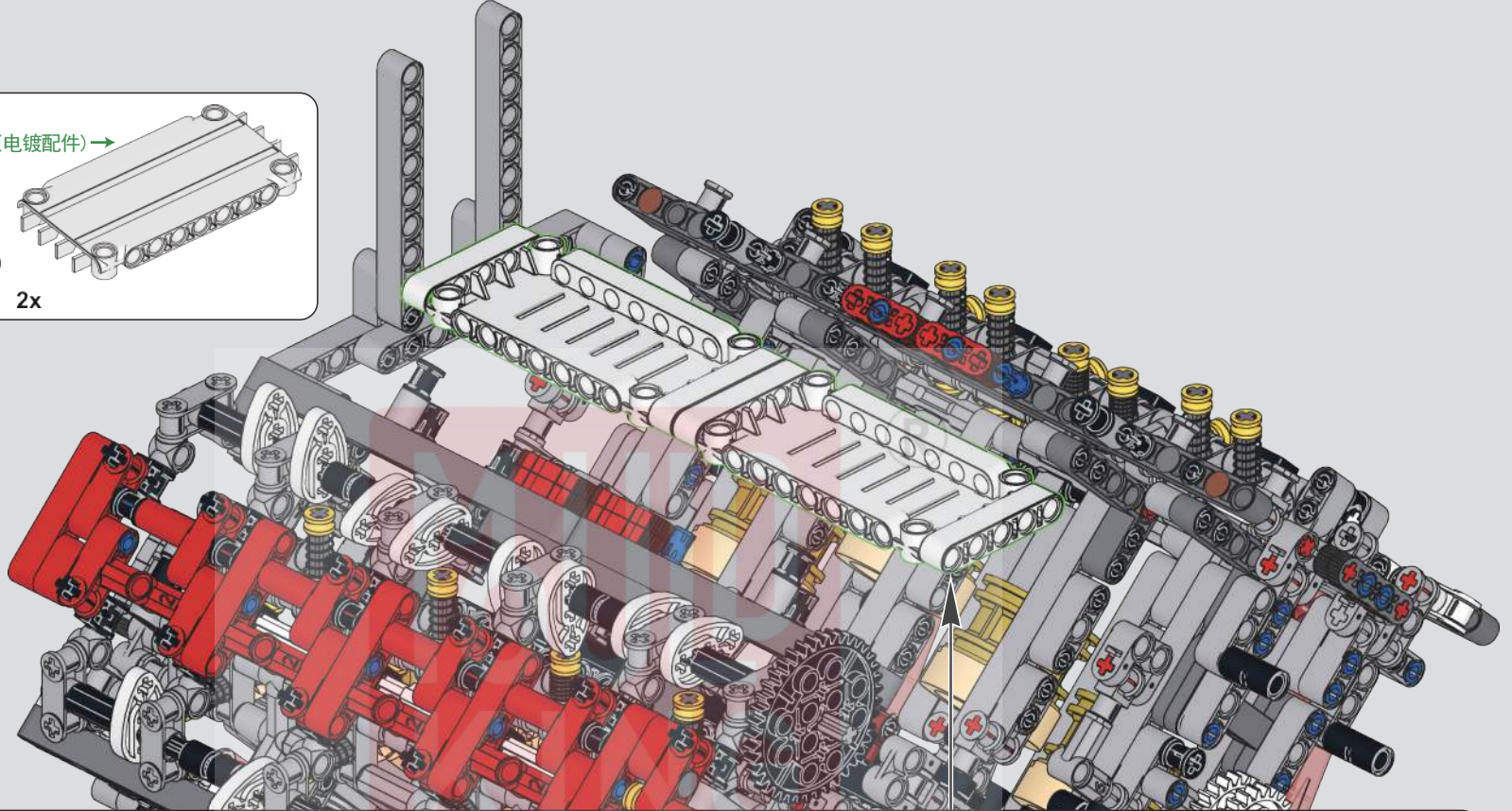

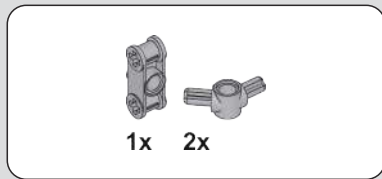
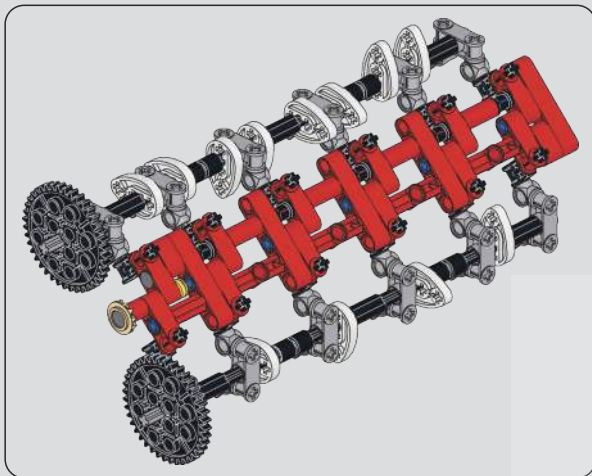

342

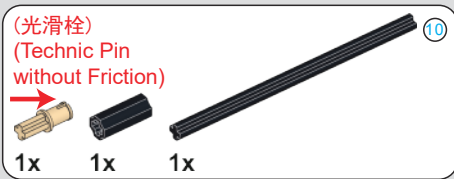
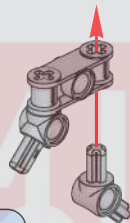

343

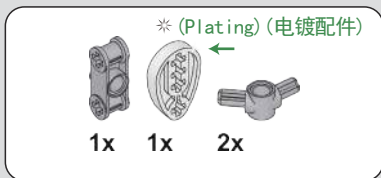
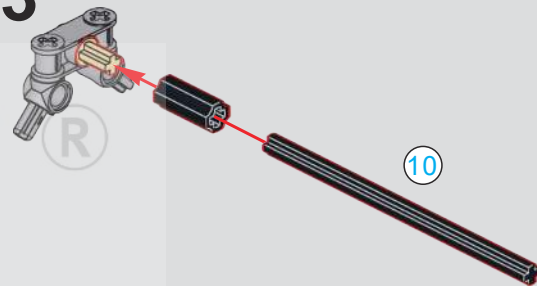

344

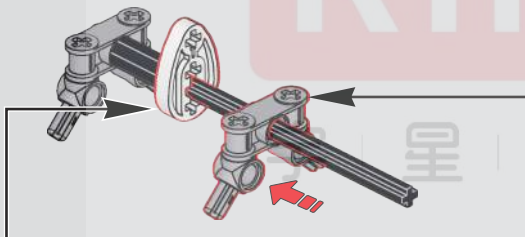

345

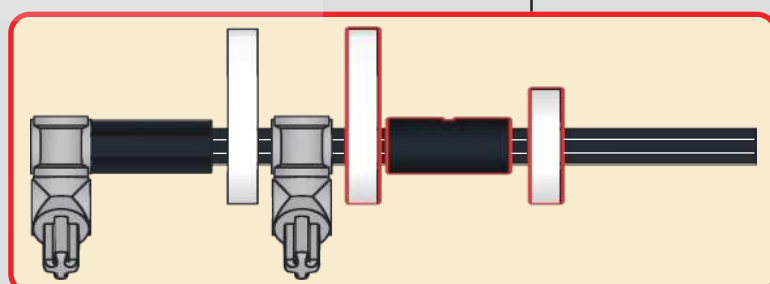
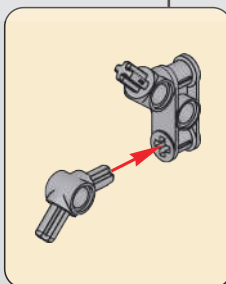
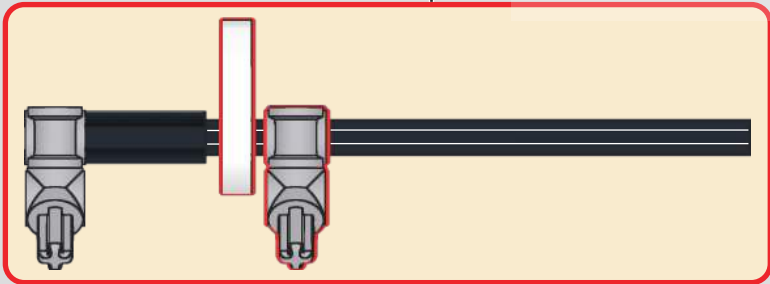
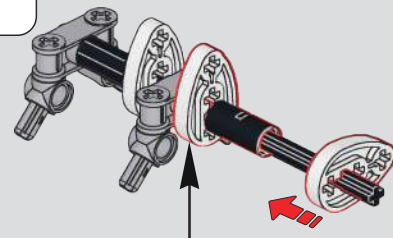

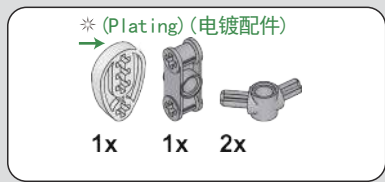

346

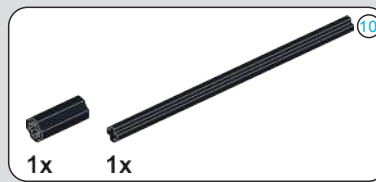
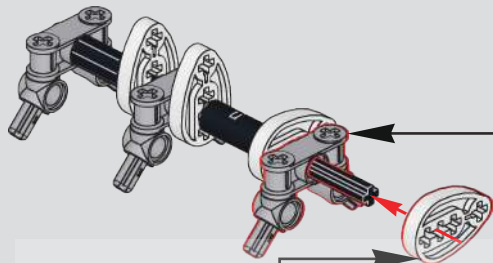

347

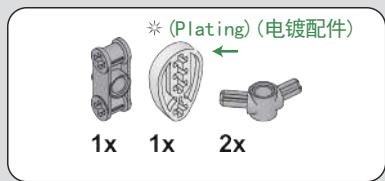
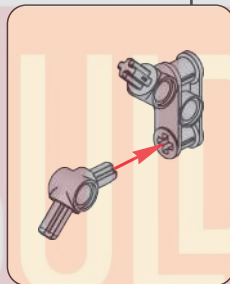
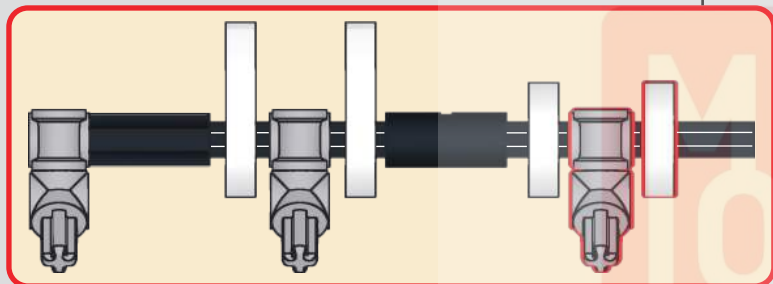
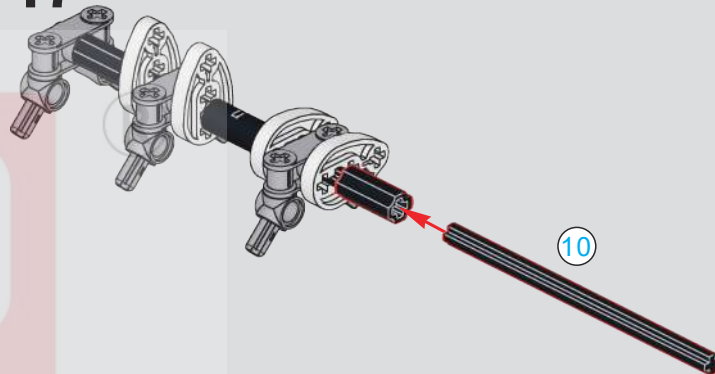

348

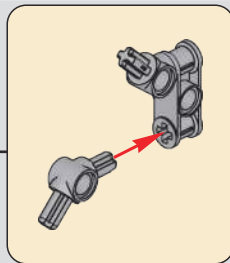
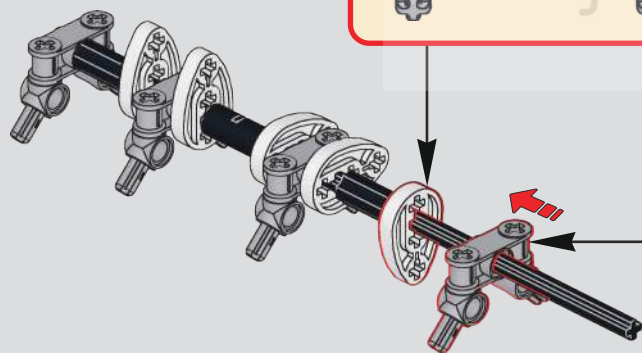
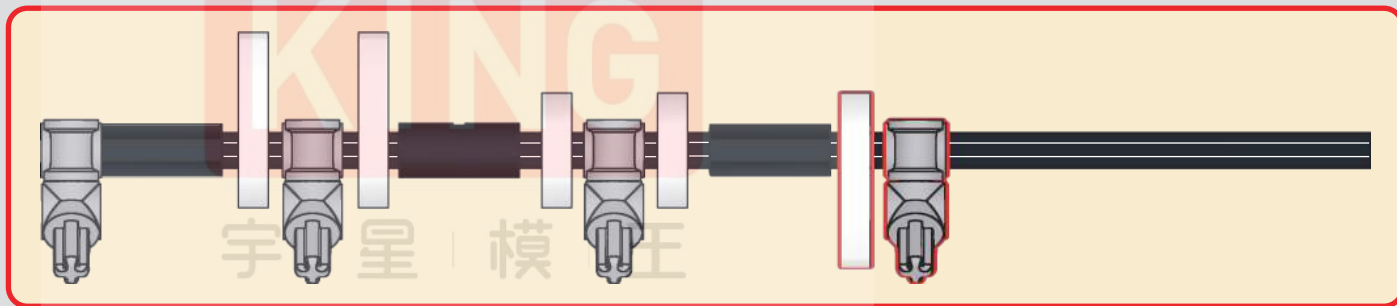



349

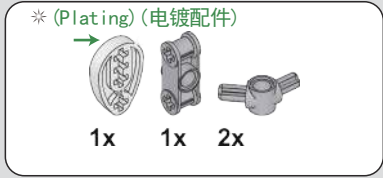
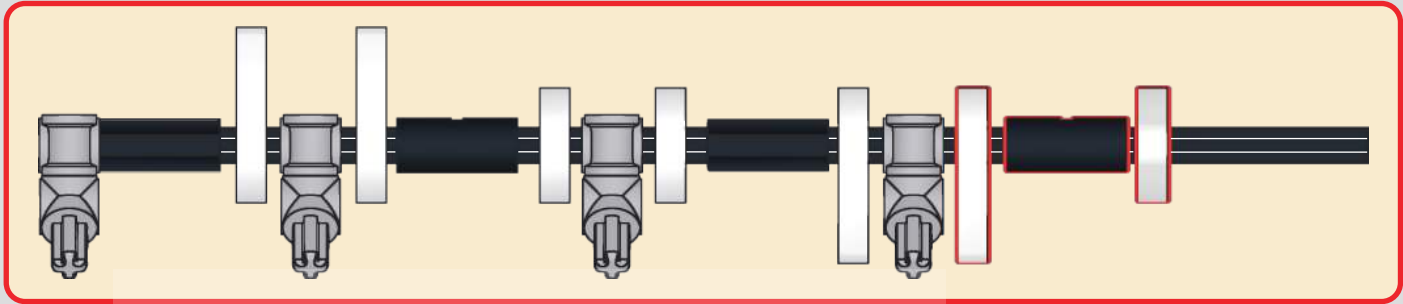
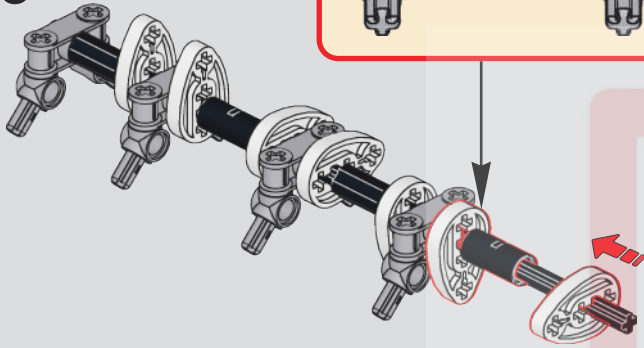

350

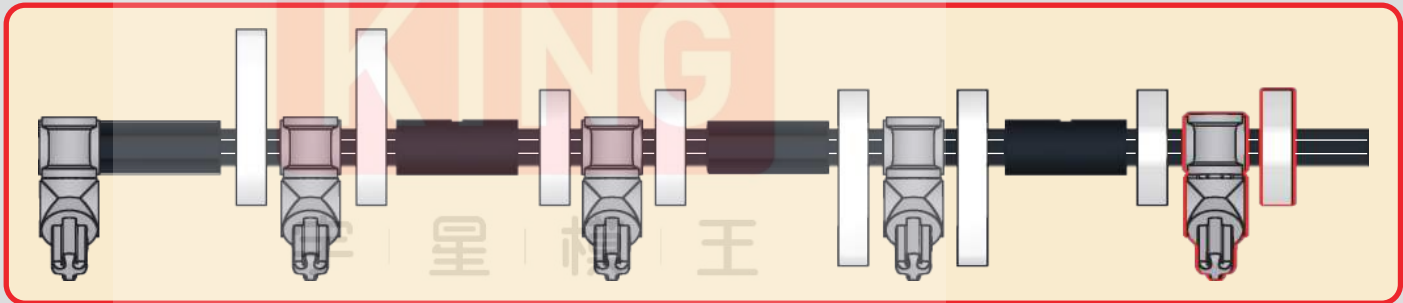
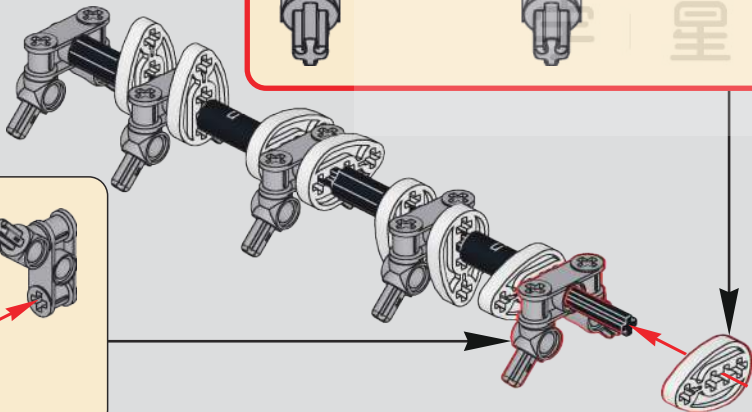
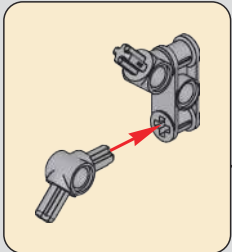

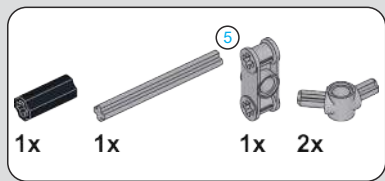

351

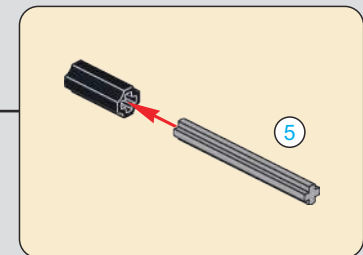
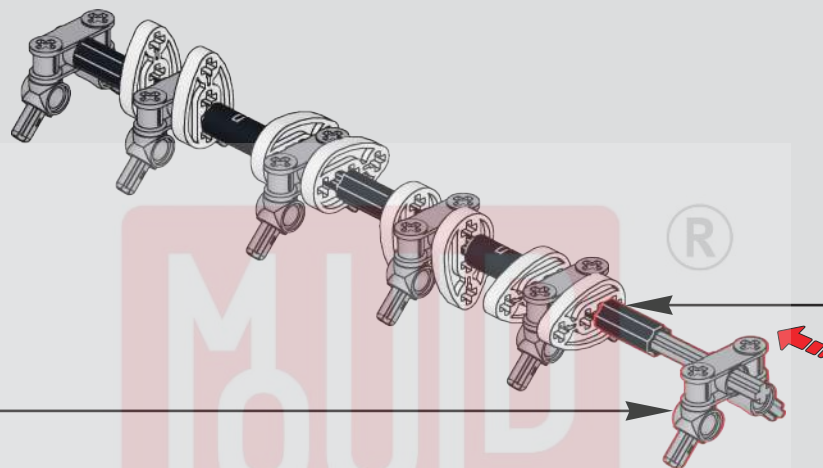
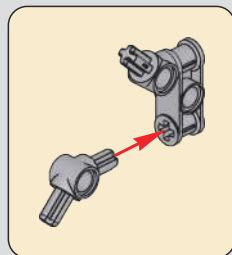
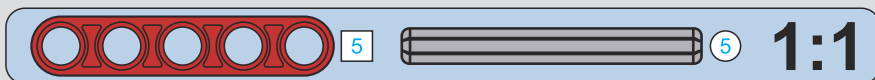

352

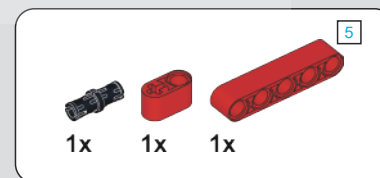
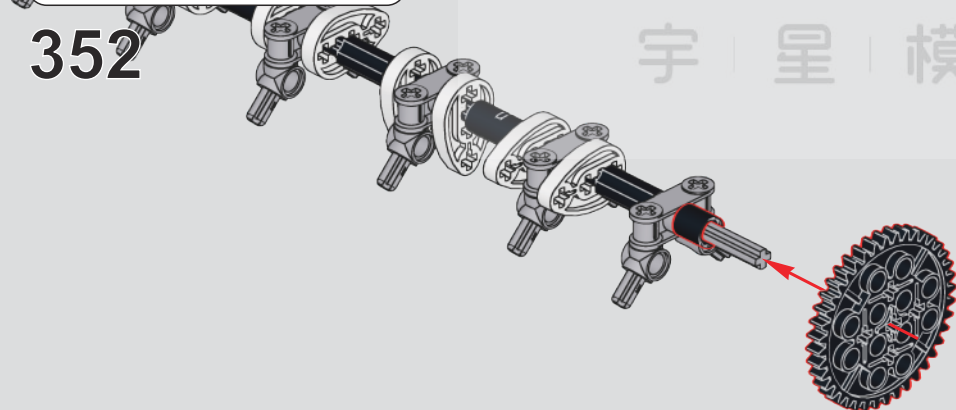
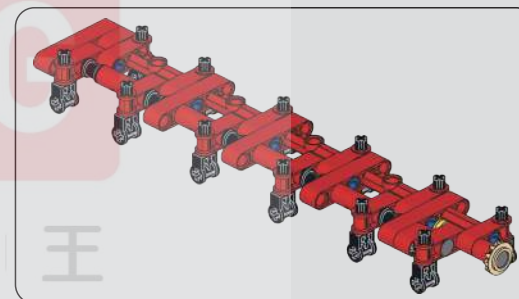

353

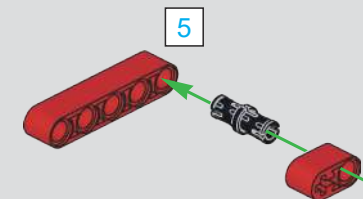

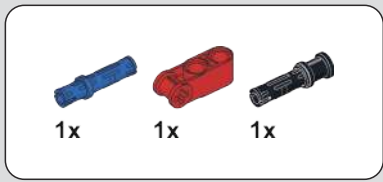

354

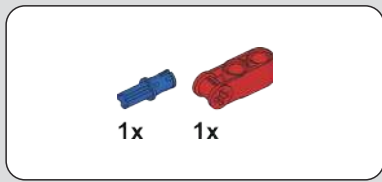
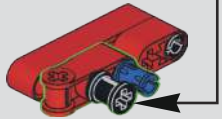
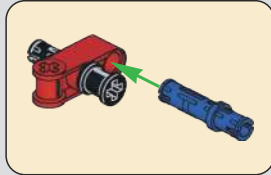

355

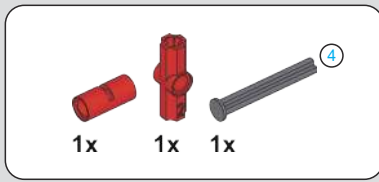
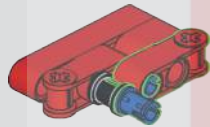

356

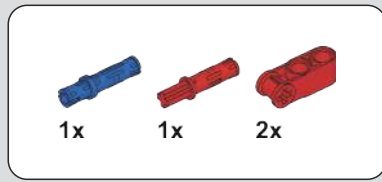
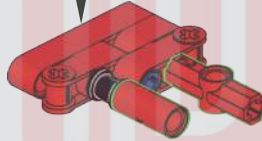

357

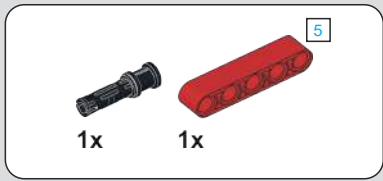
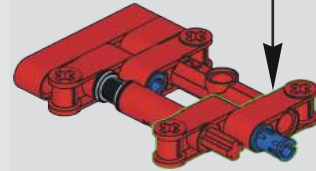
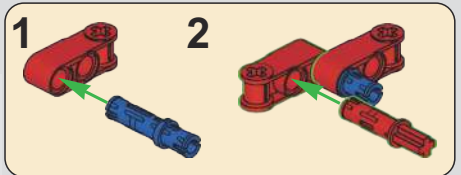

358

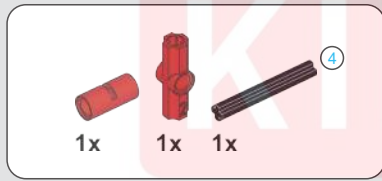
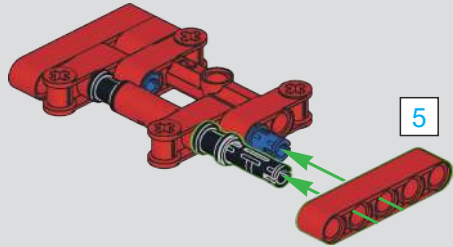

359

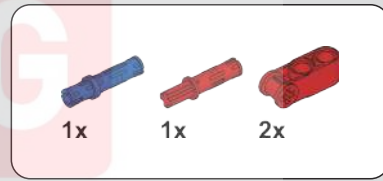
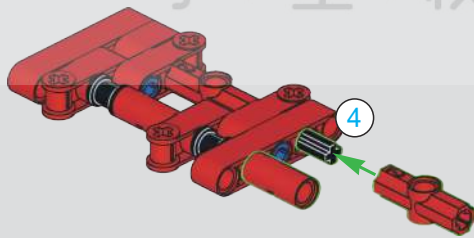

360

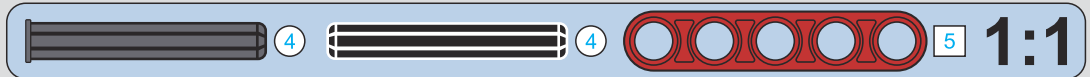
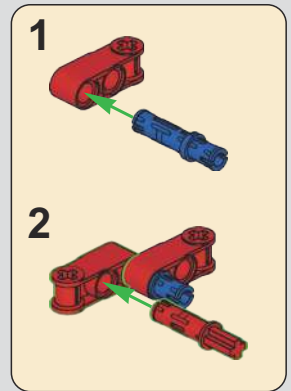
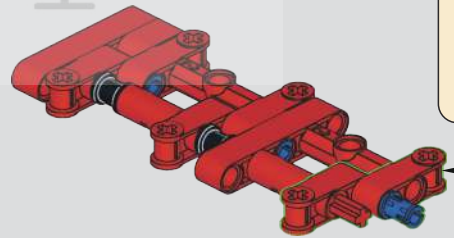

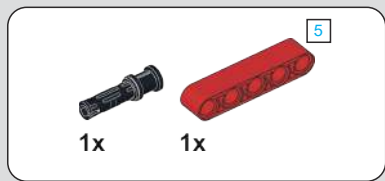

361

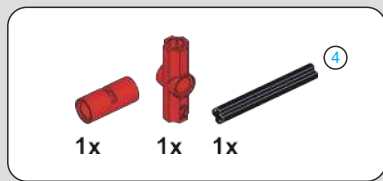
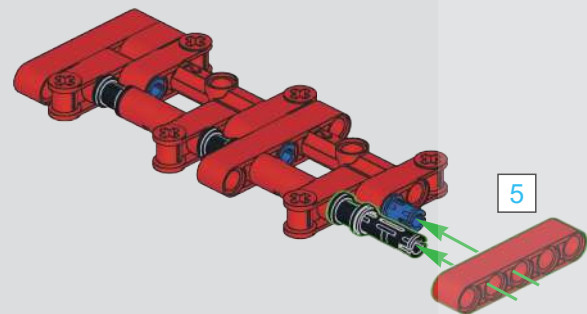

362

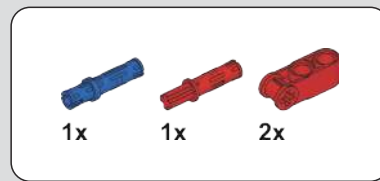
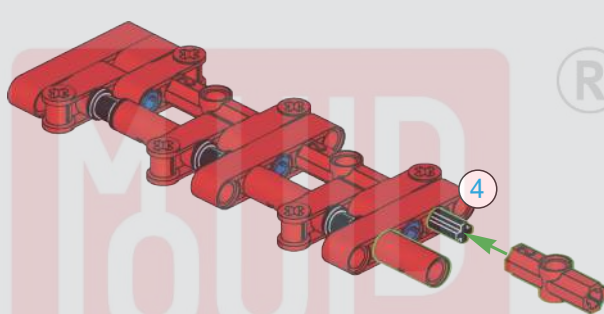

363

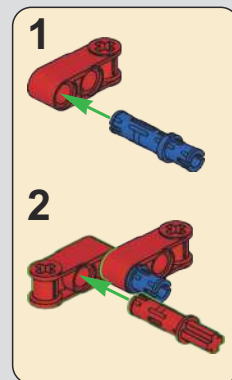
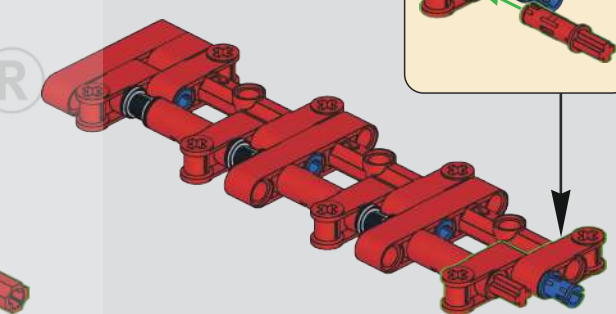

364

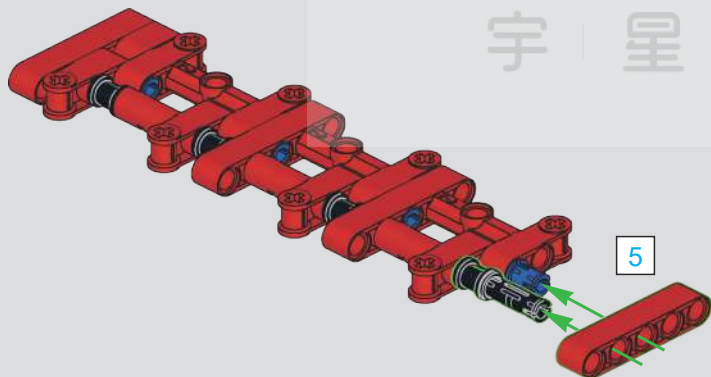

365

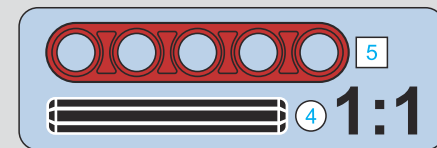
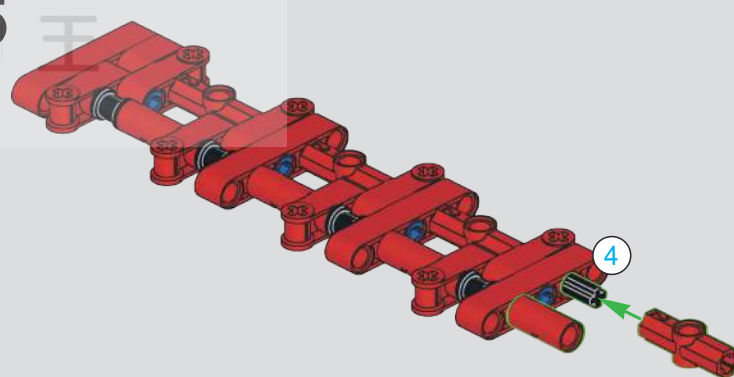

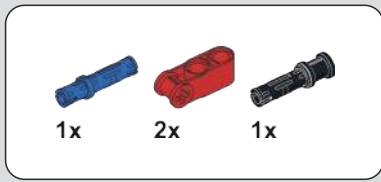

366

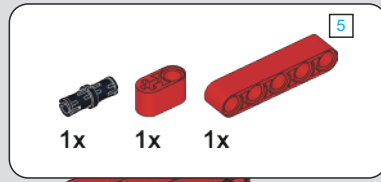
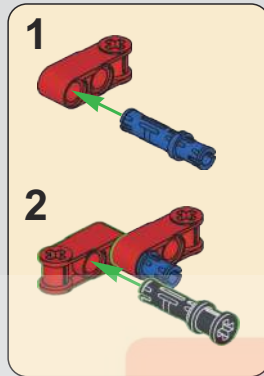
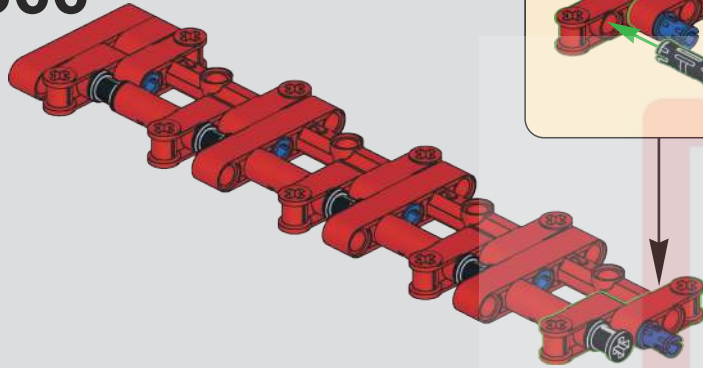

367

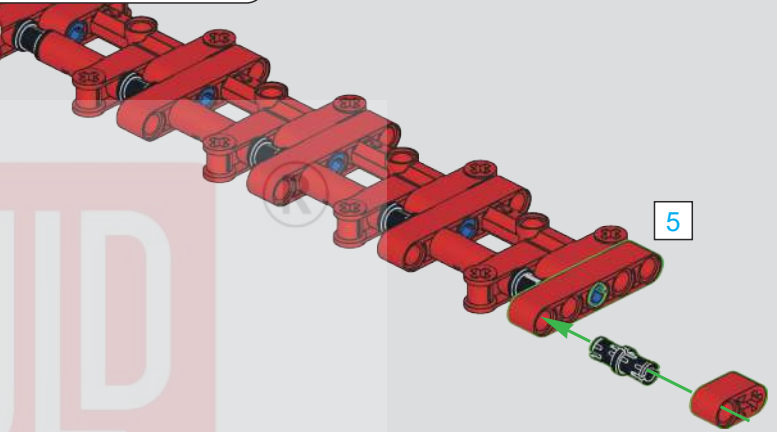

5

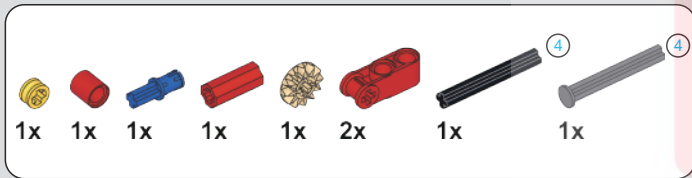

368

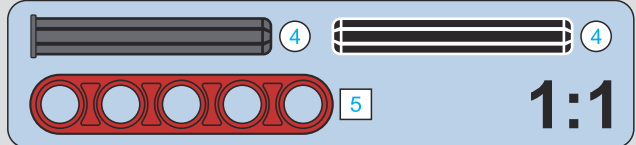
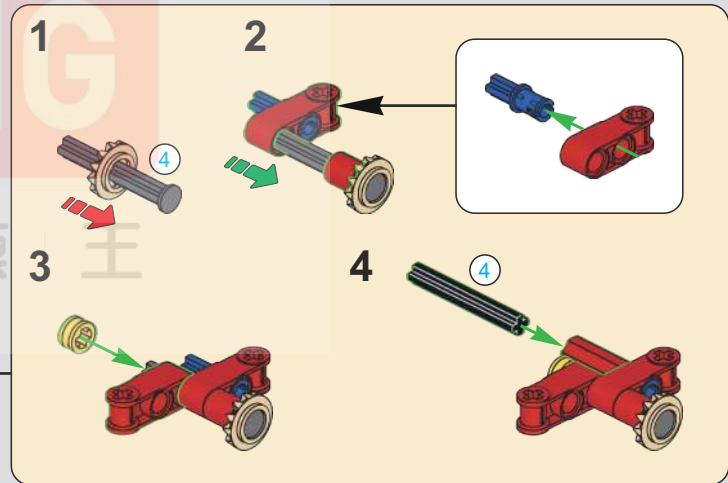
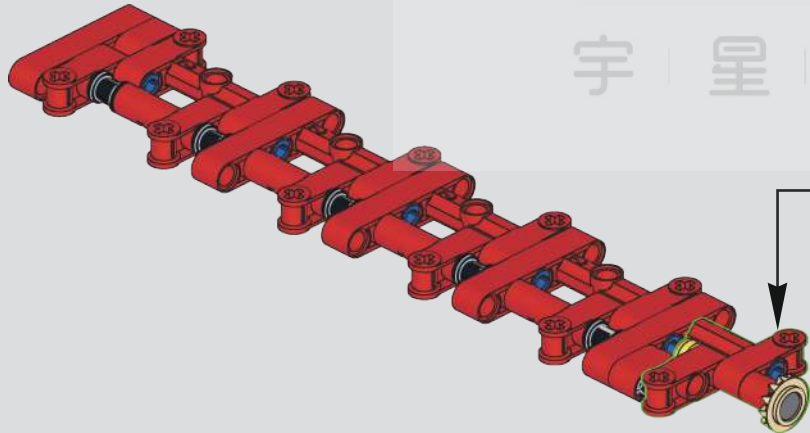

MOULD KING
宇星模具

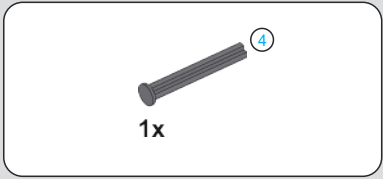

369

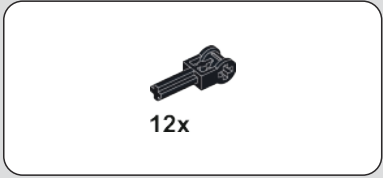

370

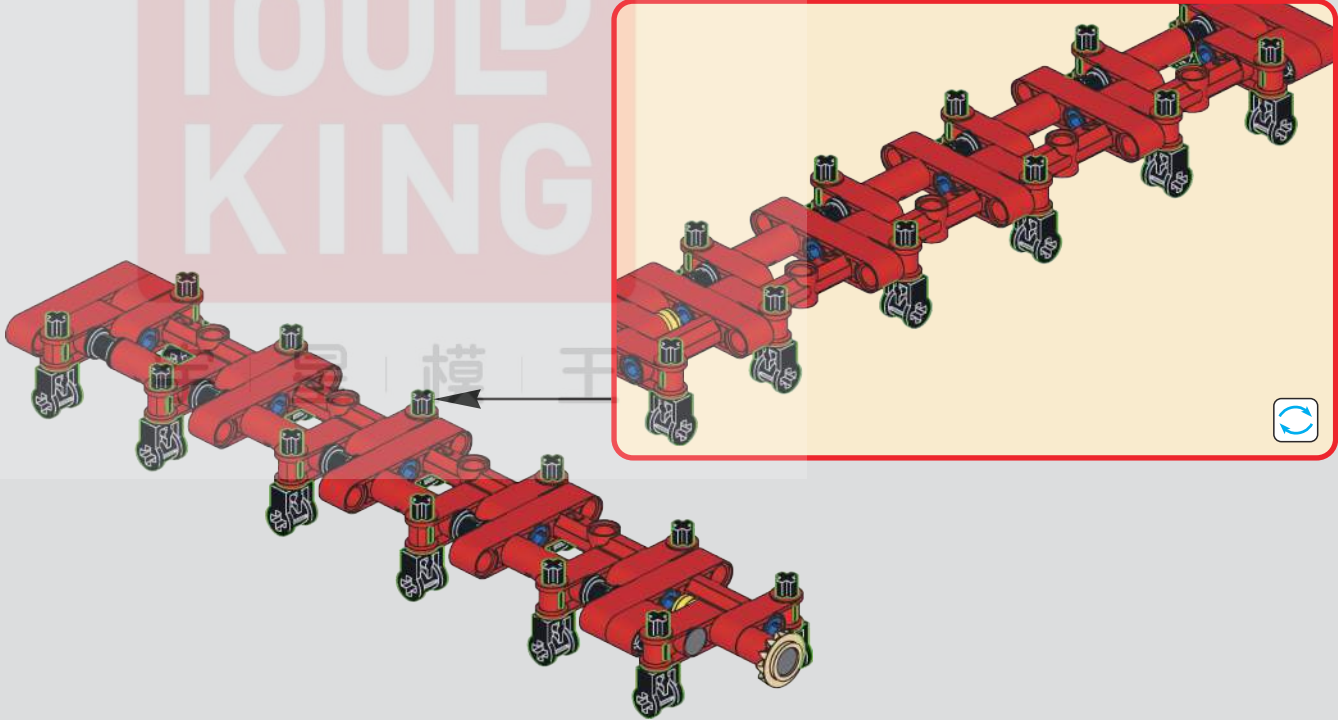
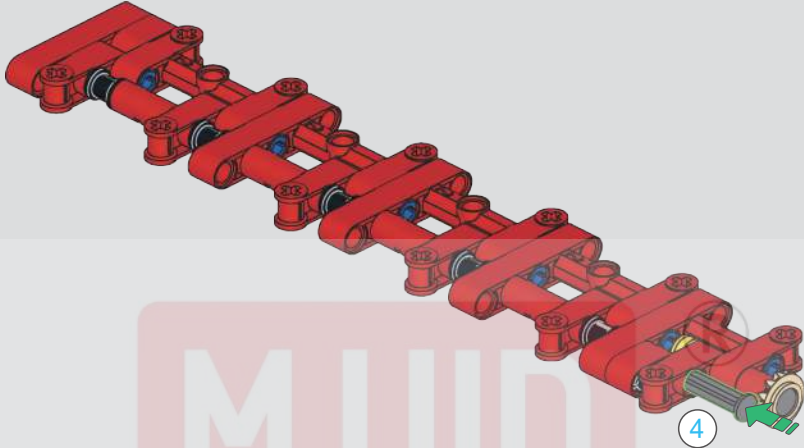

371

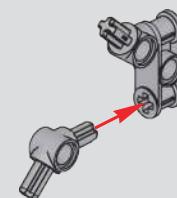
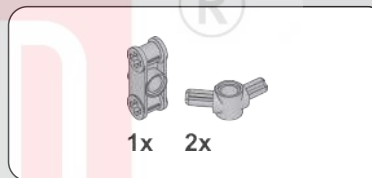
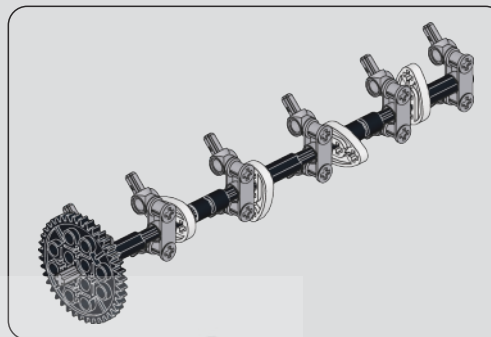
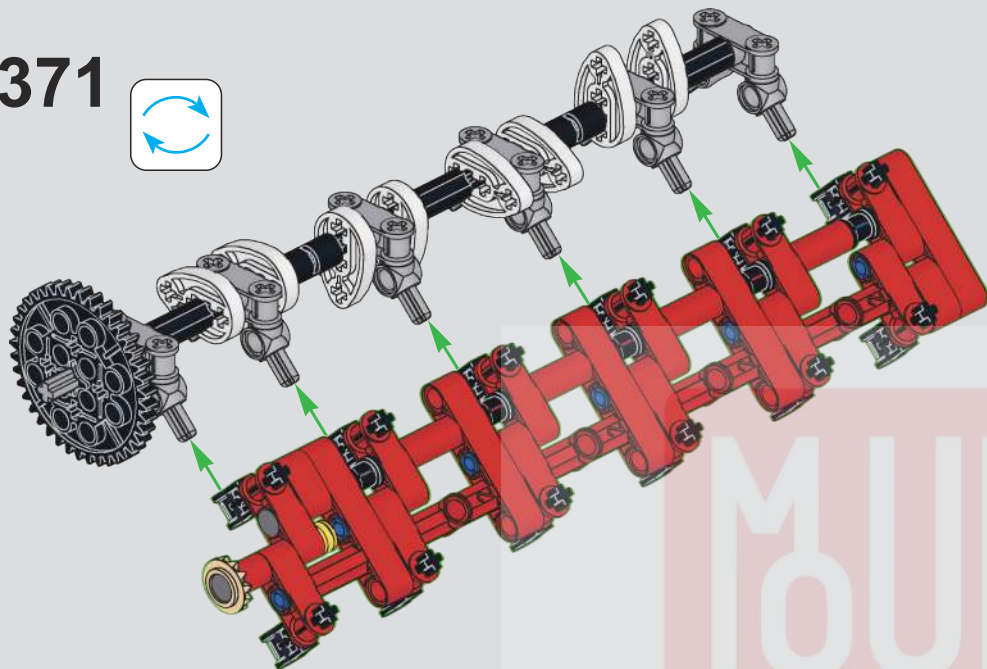

372

(光滑栓)
(Technic Pin
without Friction)

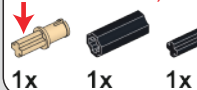

373

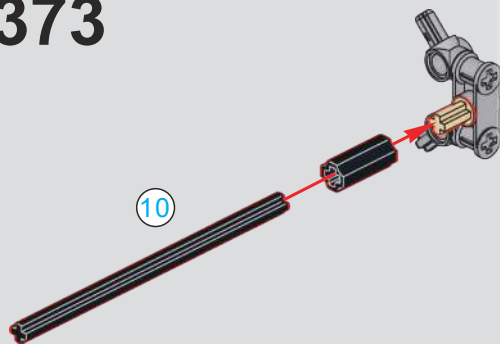

* (Plating) (电镀配件)

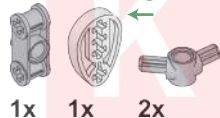

374

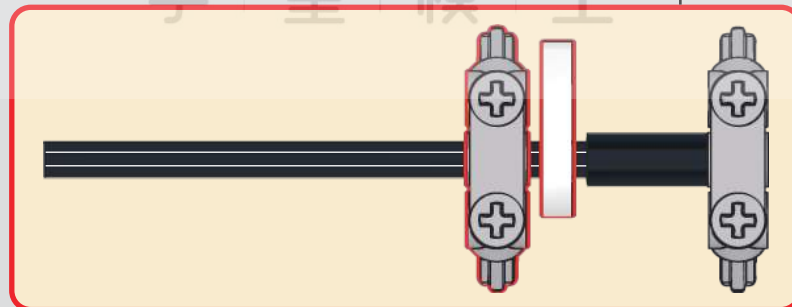

1:1

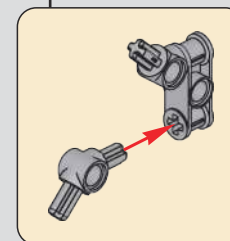
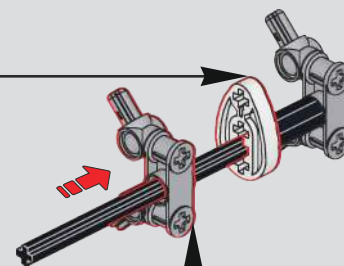



375

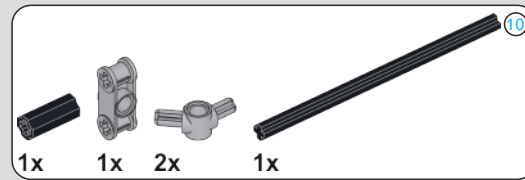
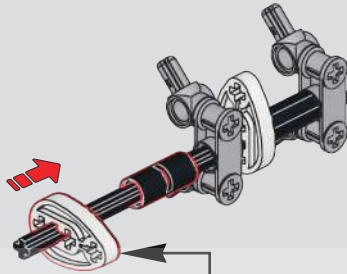

376

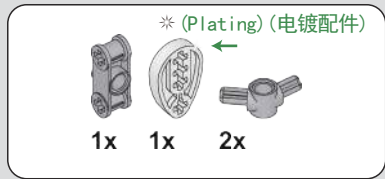
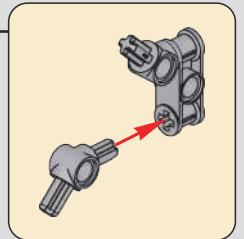
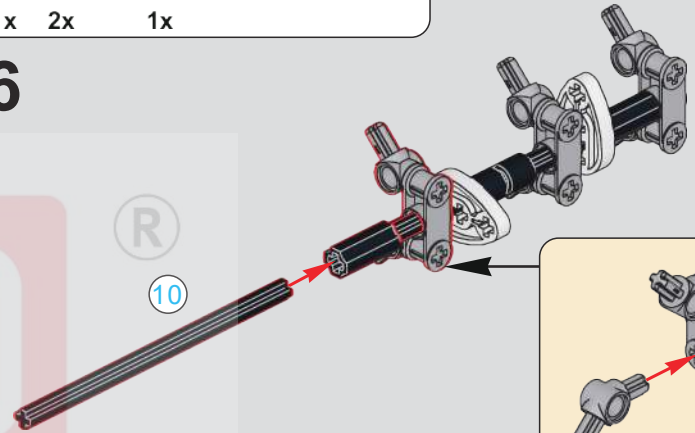
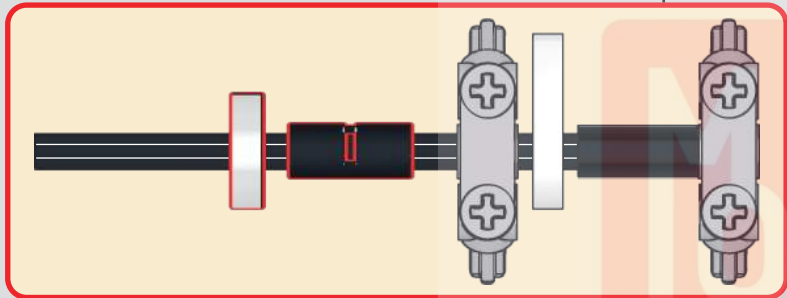

377

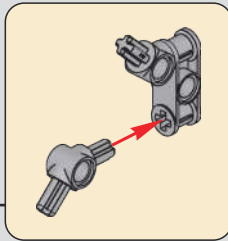
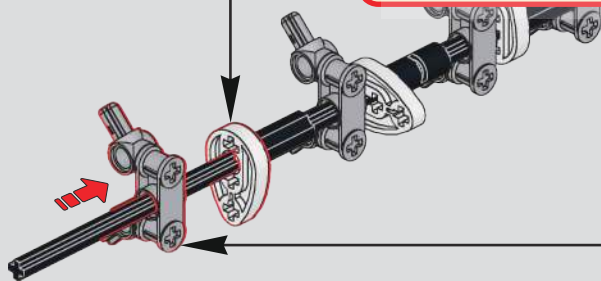
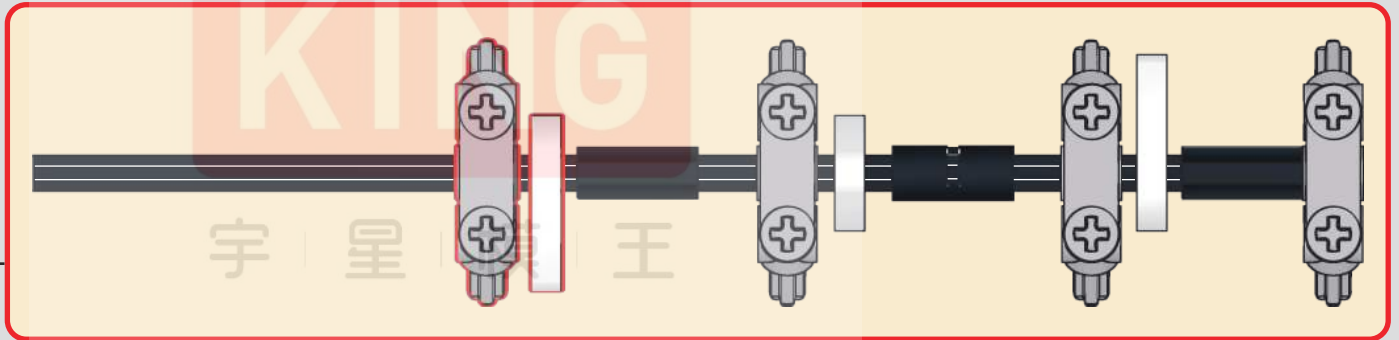

* (Plating) (电镀配件)



1x 1x

378

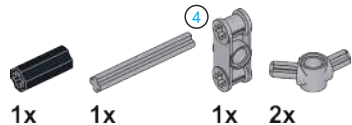
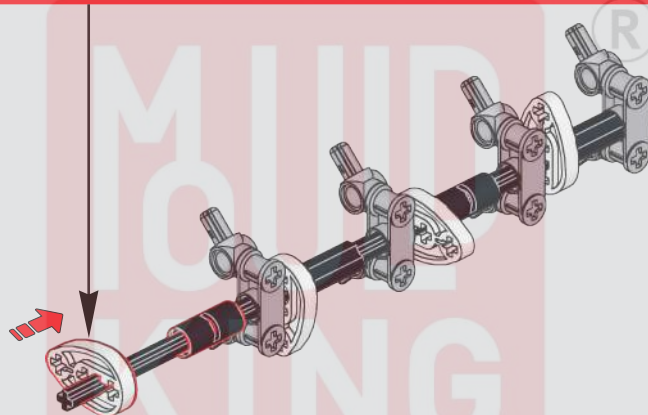
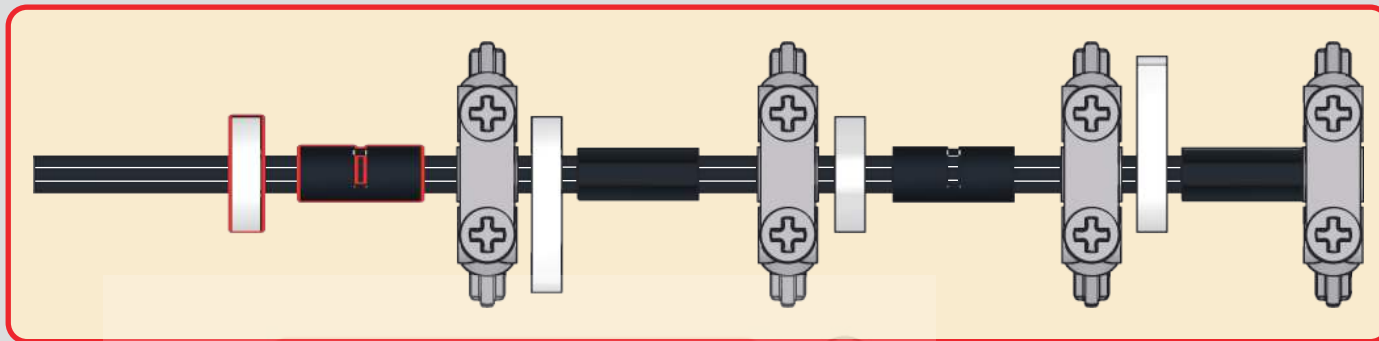

1x 1x 1x 2x

379

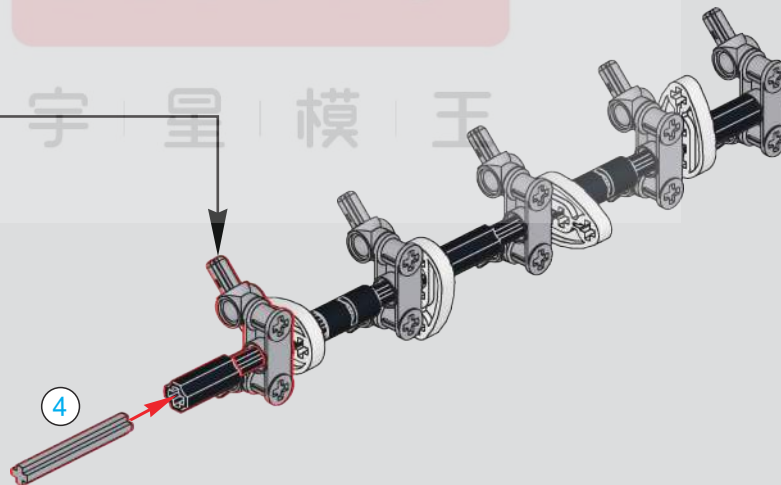
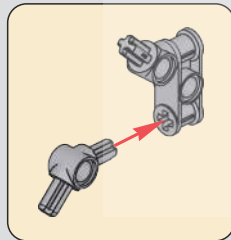

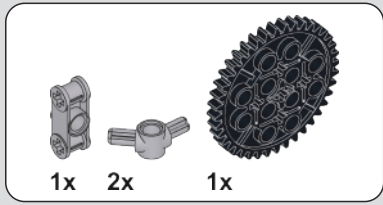

380

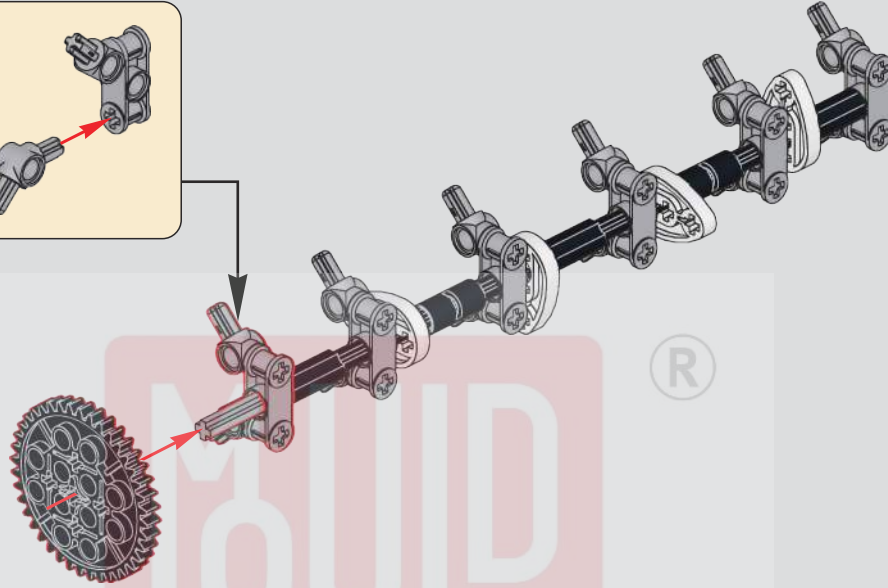
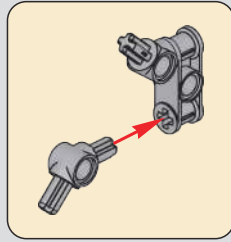



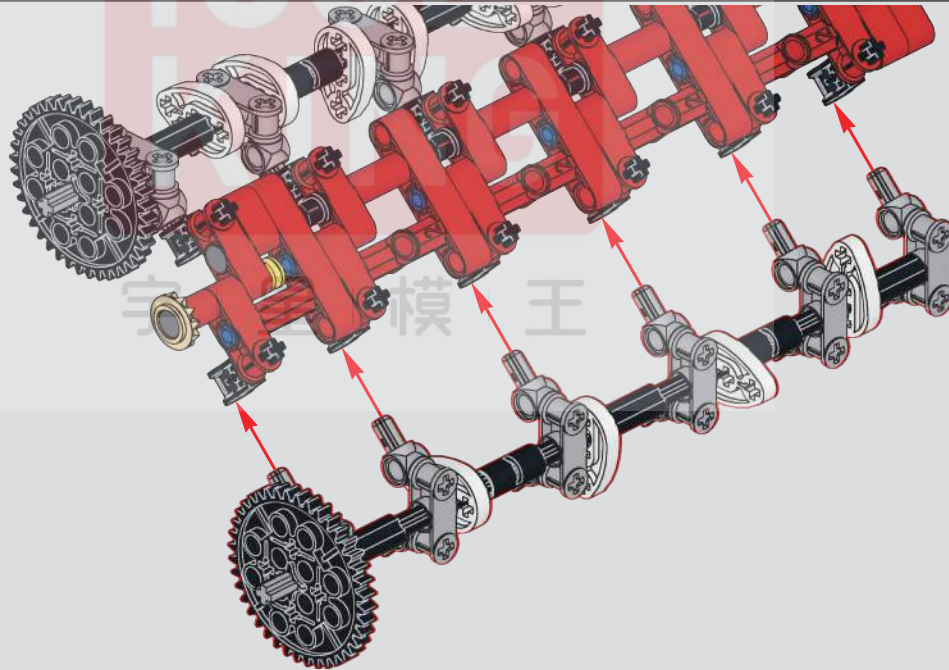



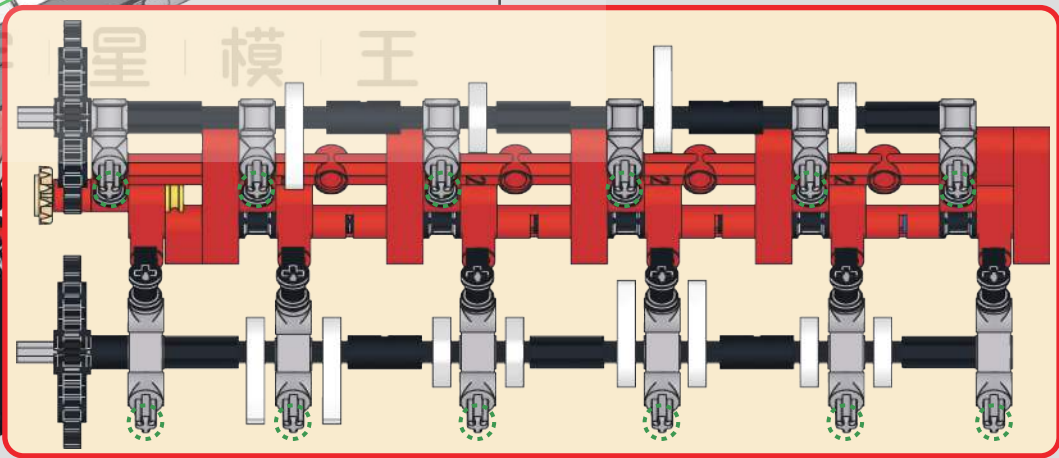
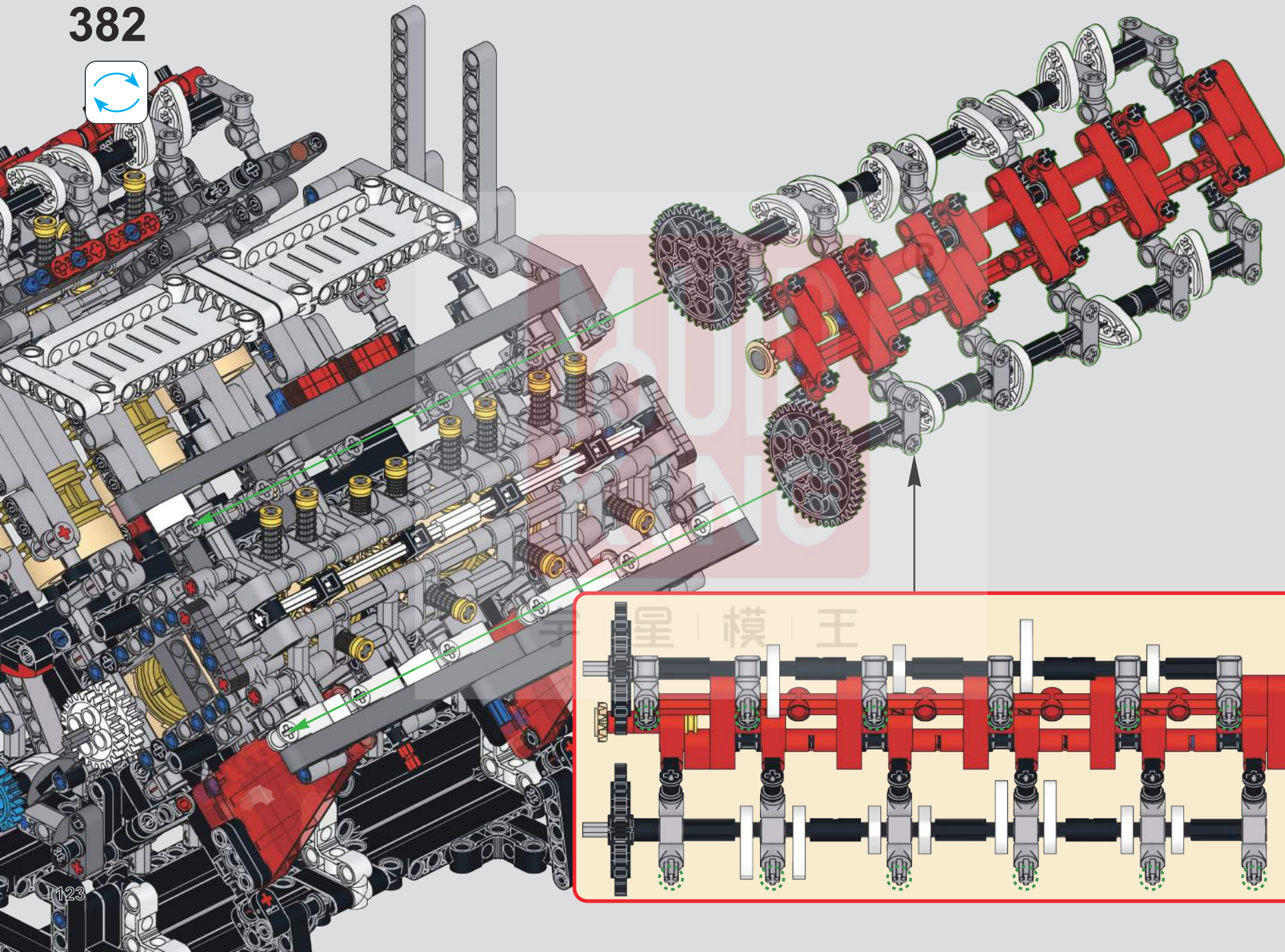

381



382



-  8x
-  16x
-  8x
-  8x
-  16x
-  16x
-  8x
-  8x

383

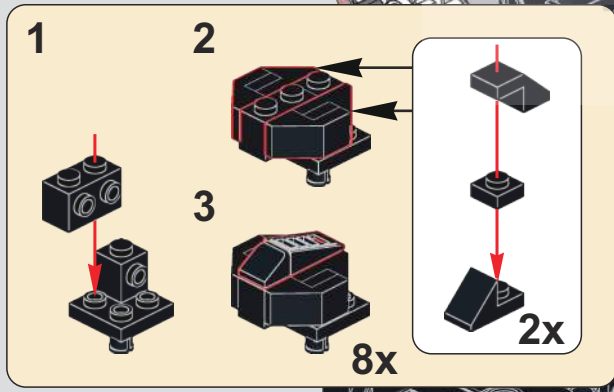
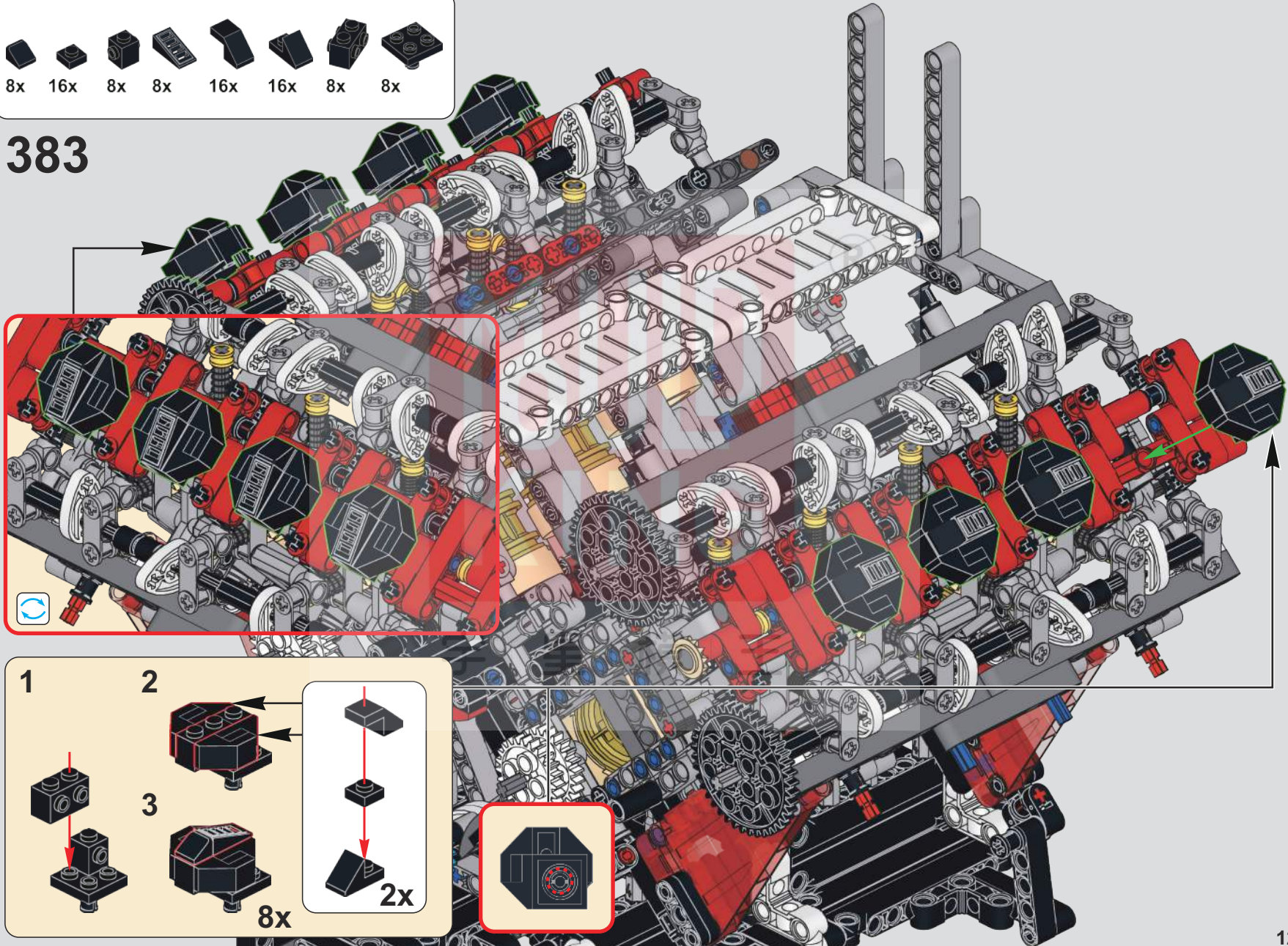

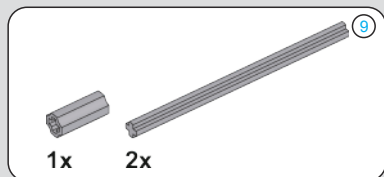
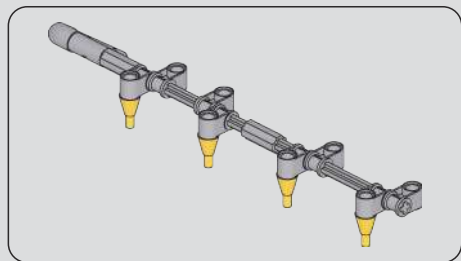
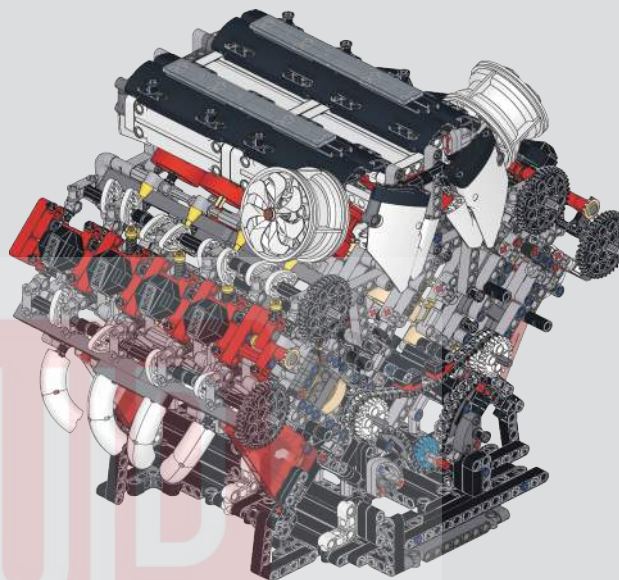

384

9



385

4x

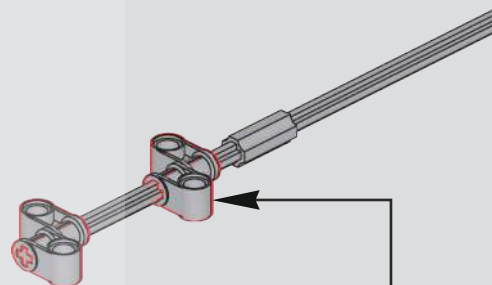

9

1:1

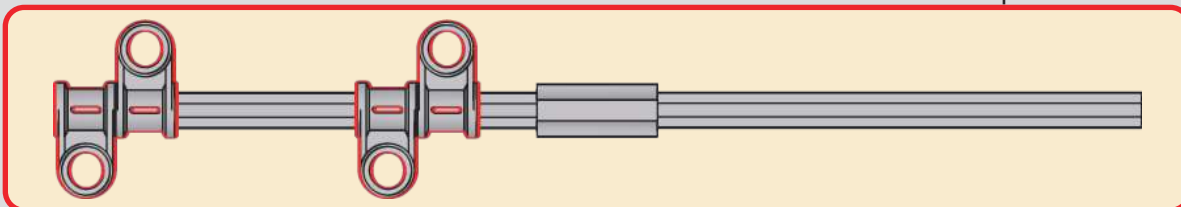

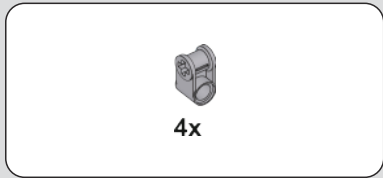

386

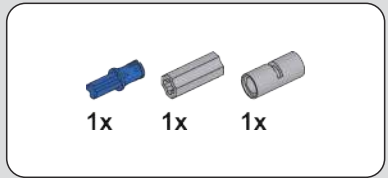
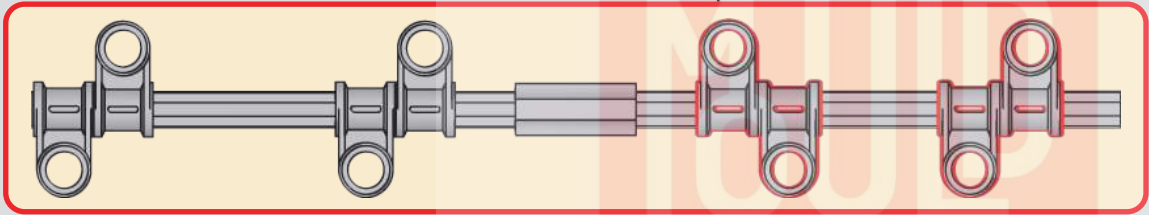
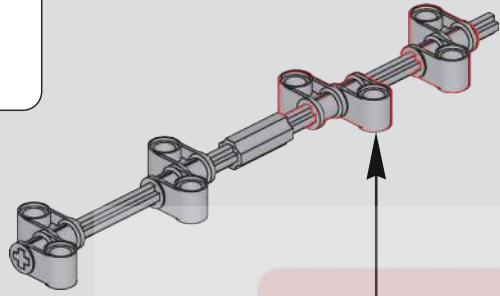

387

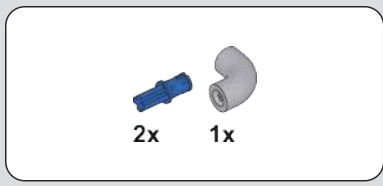
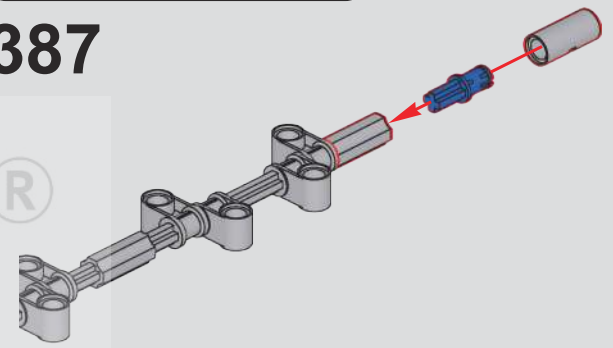

388

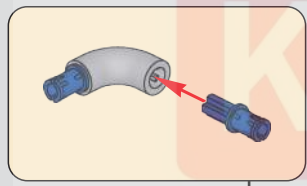
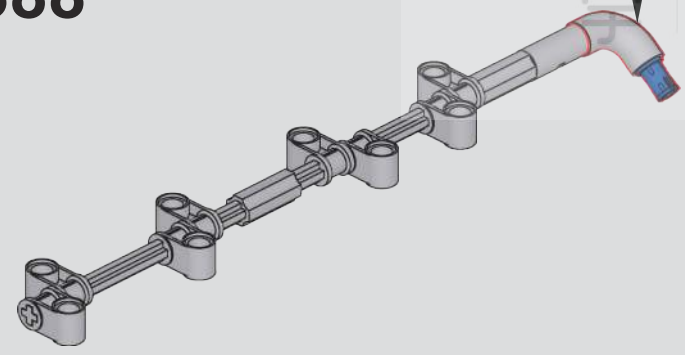

389

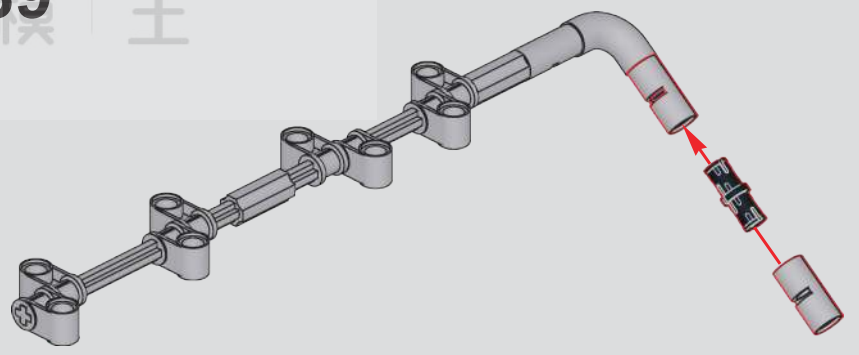

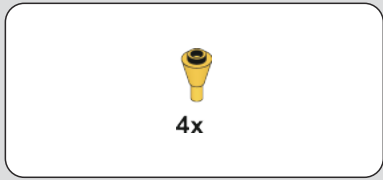

390

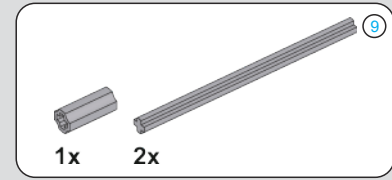
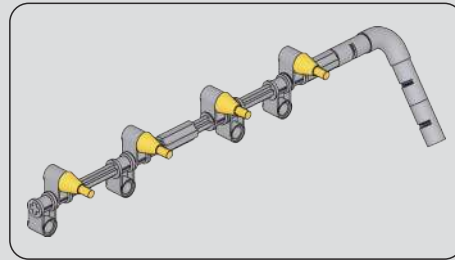
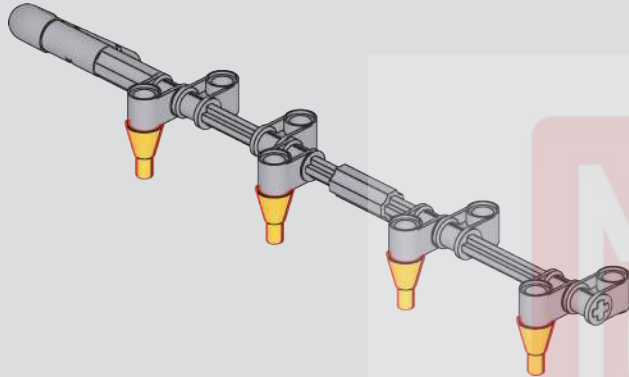

391

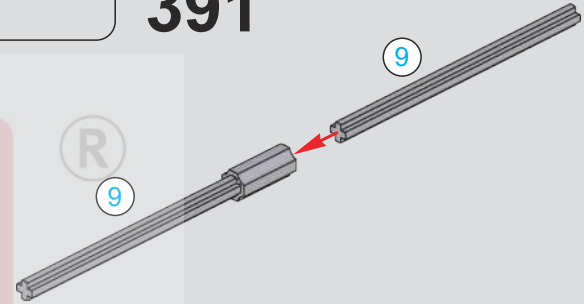

392

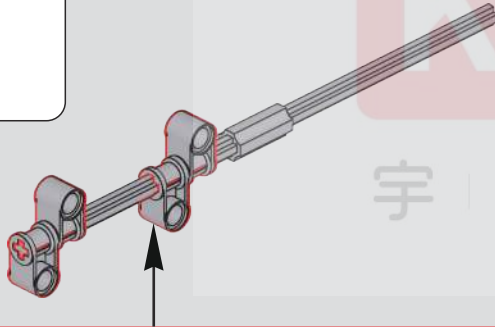

393

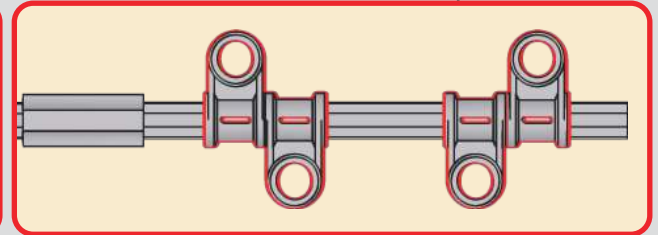
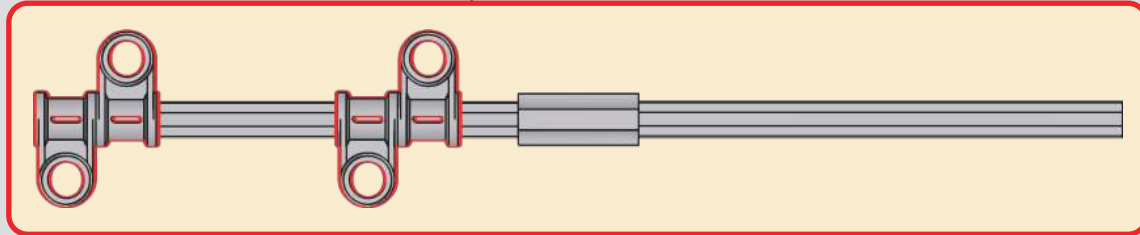
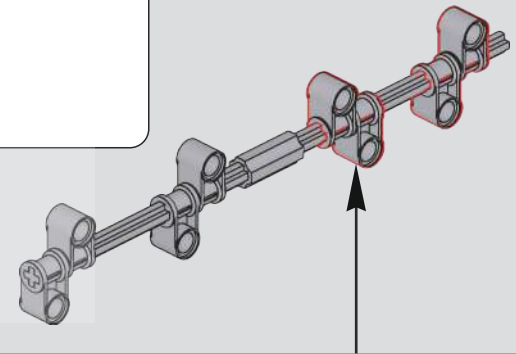

MOULD KING
宇 | 星 | 模 | 王

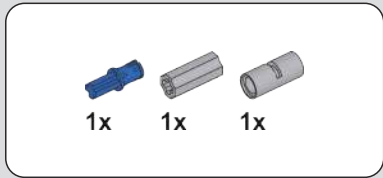

394

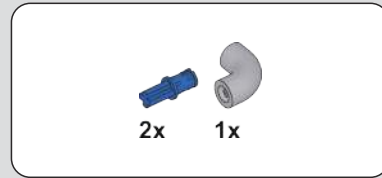
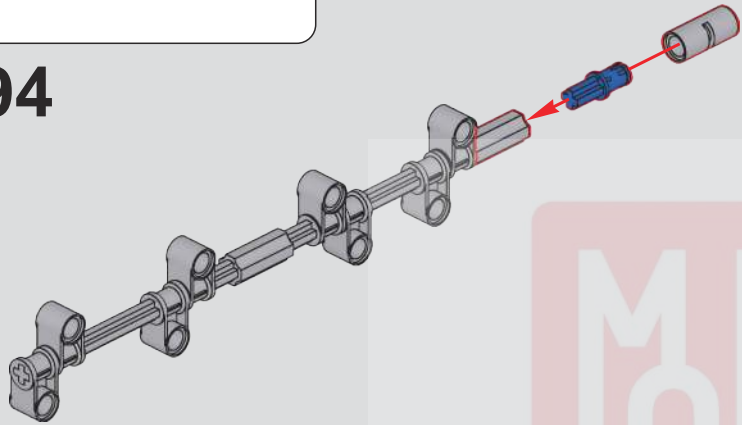

395

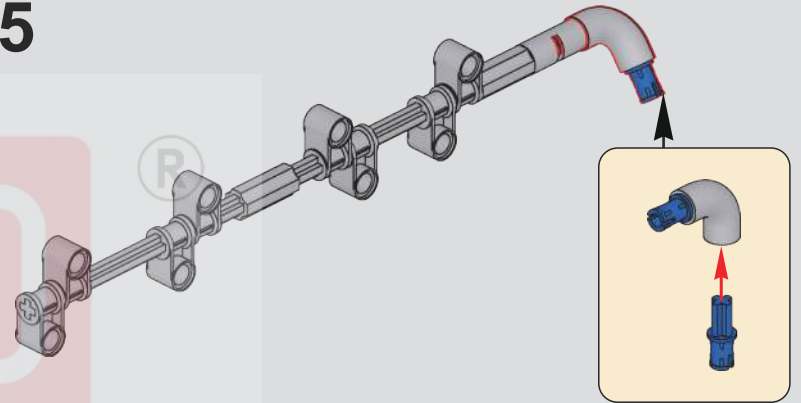

396

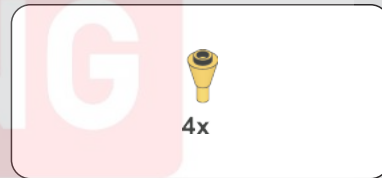
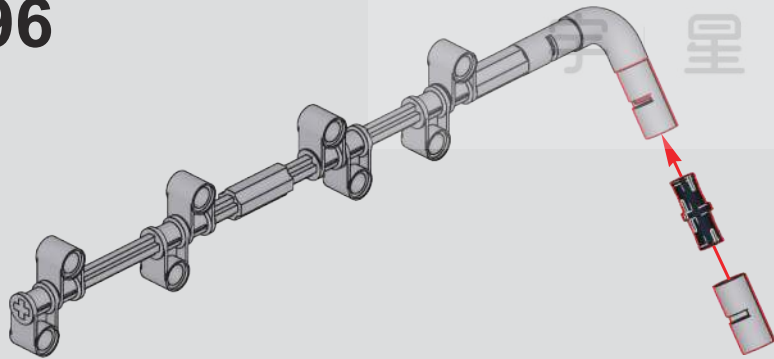

397

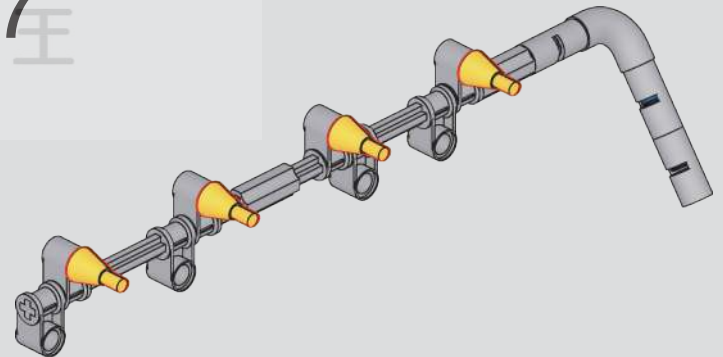

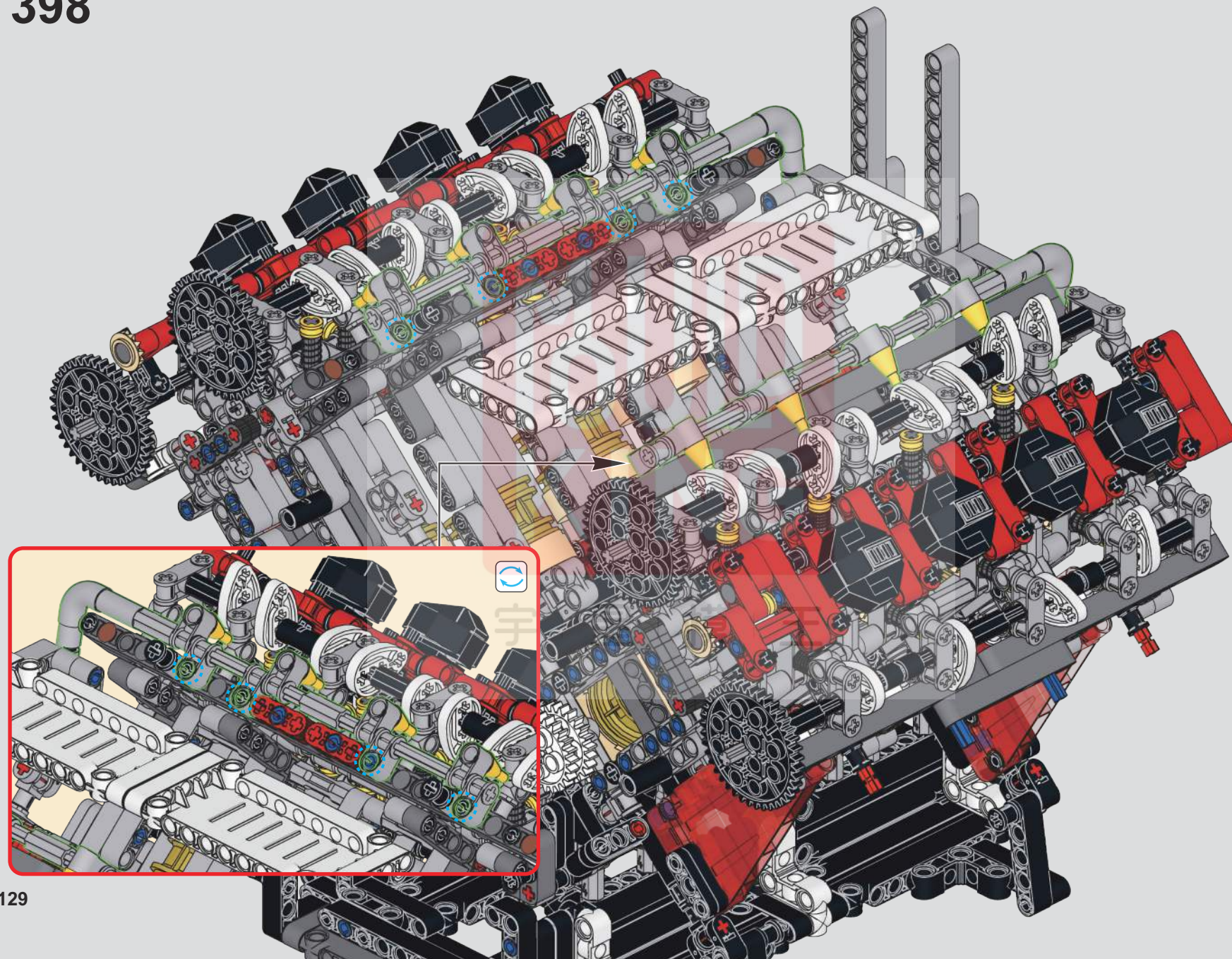

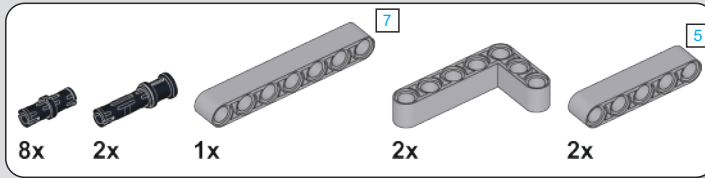

399

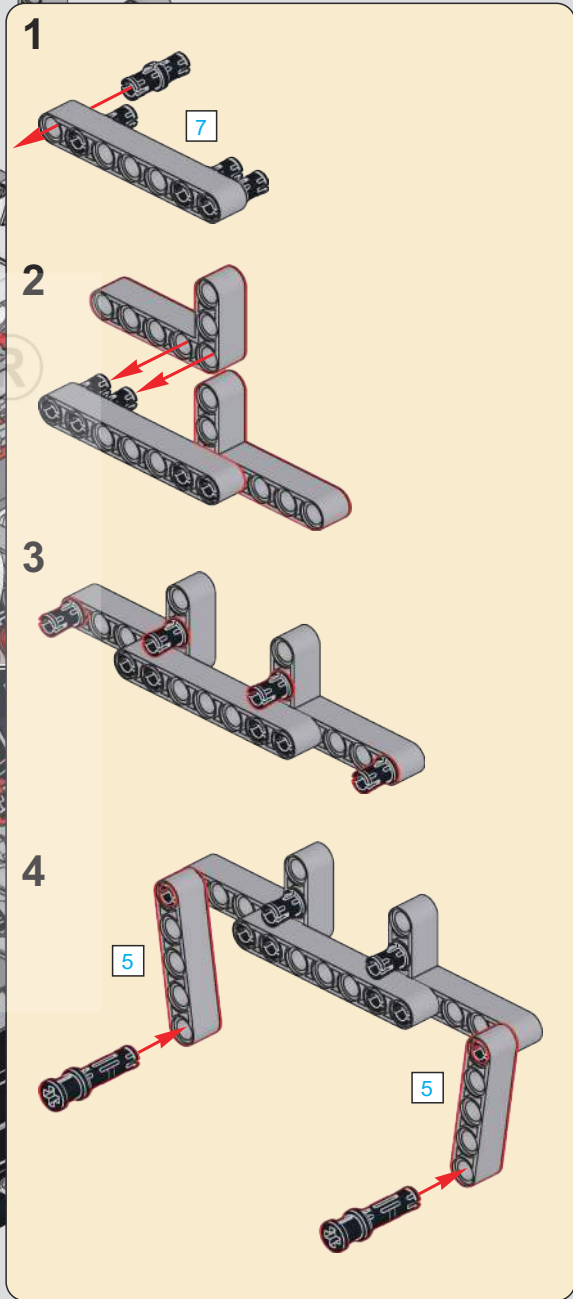
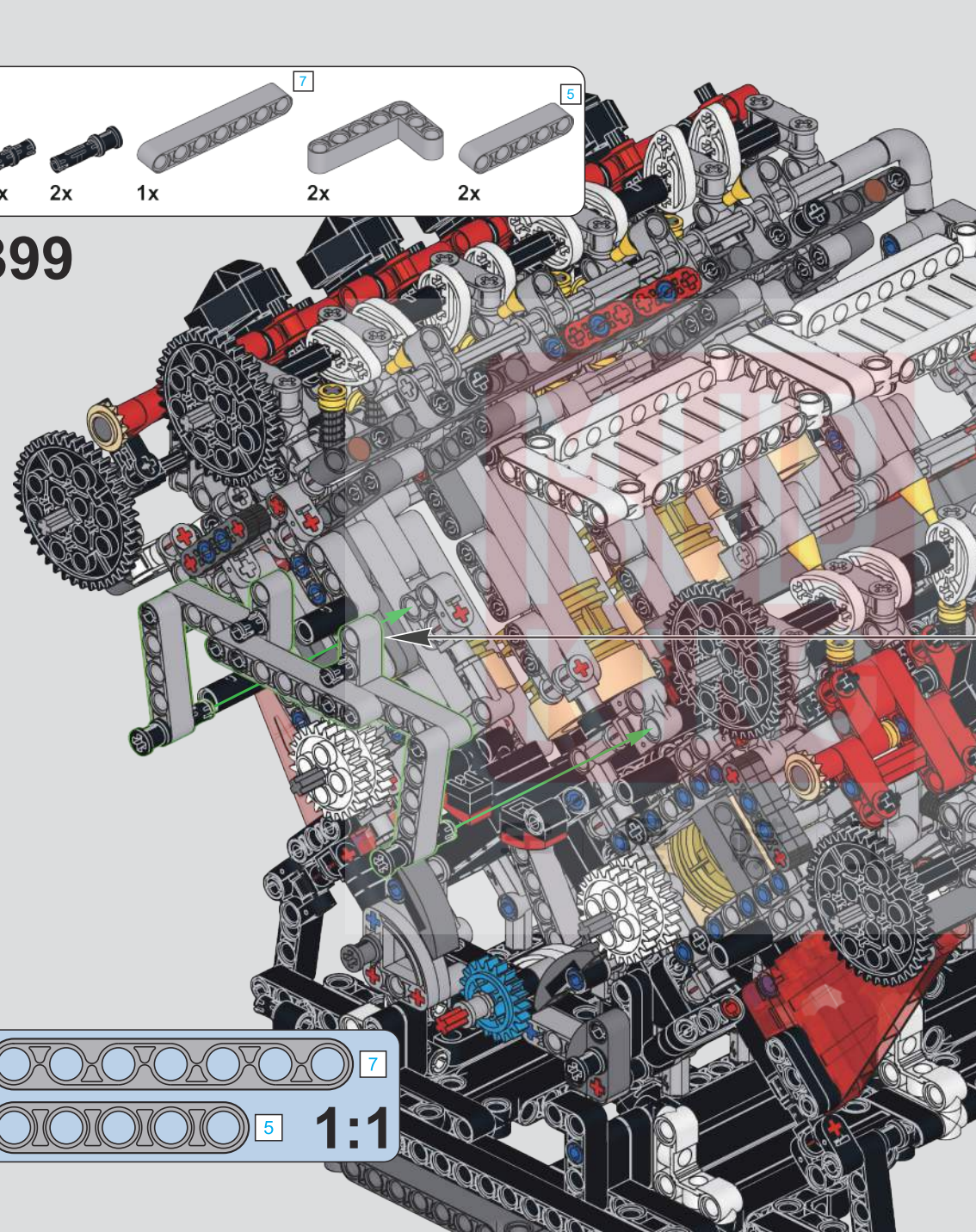
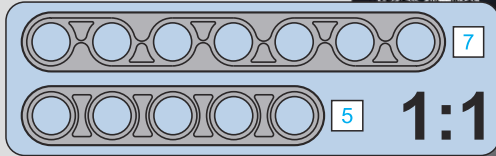

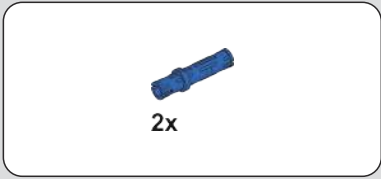

400

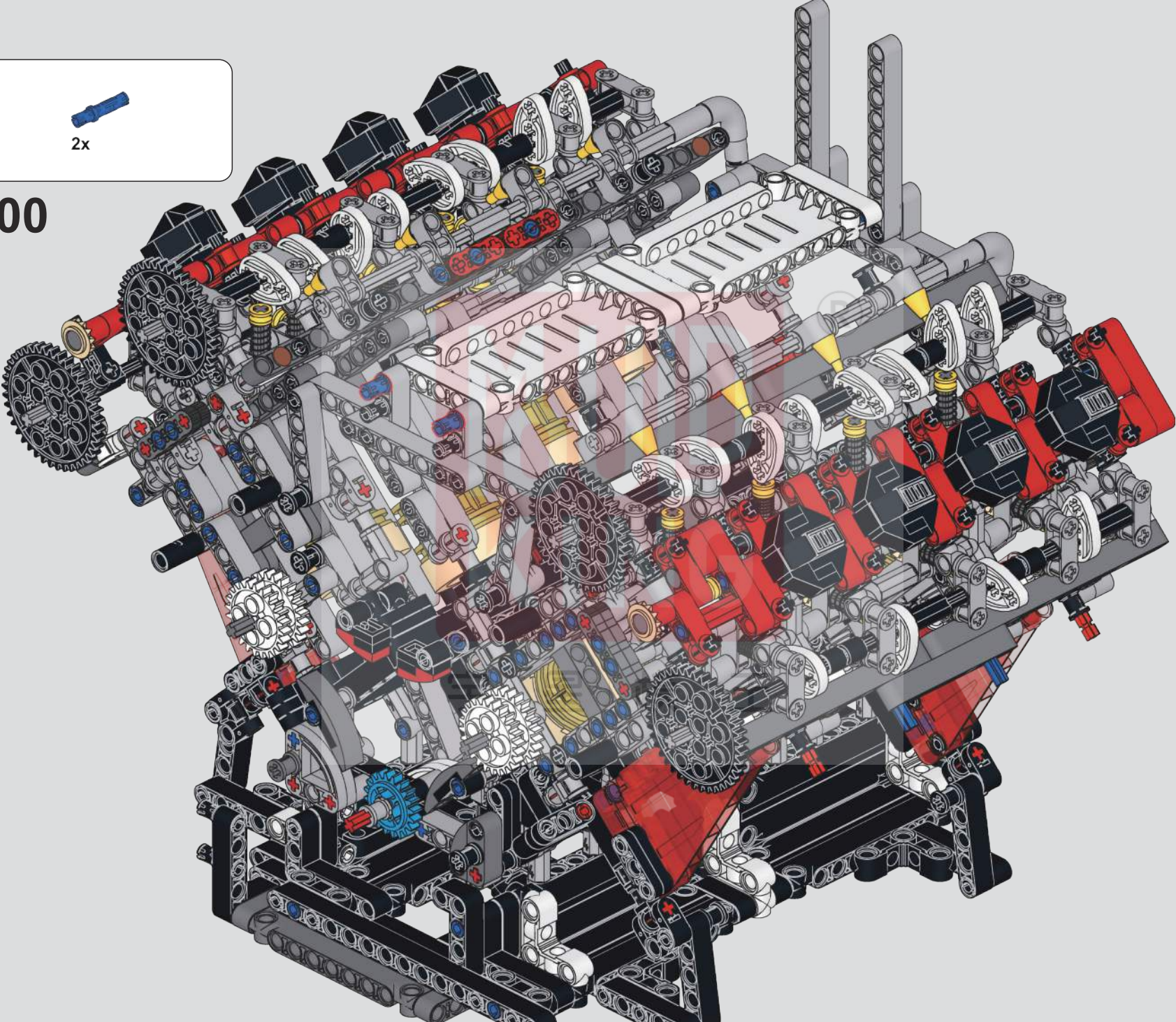

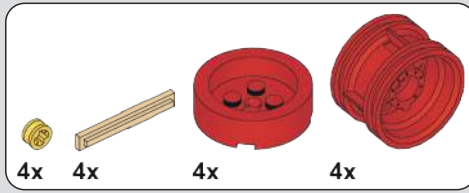

401

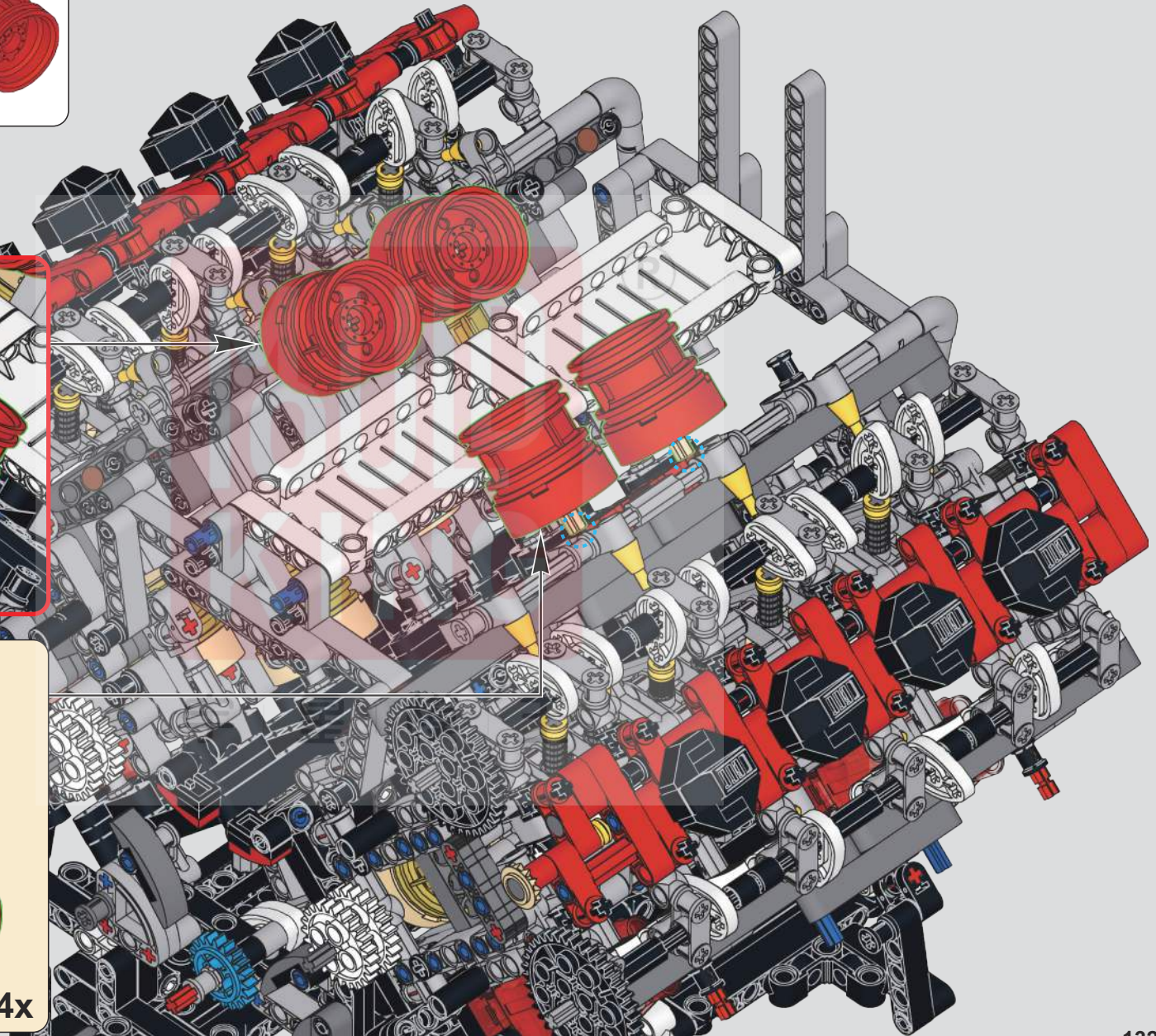
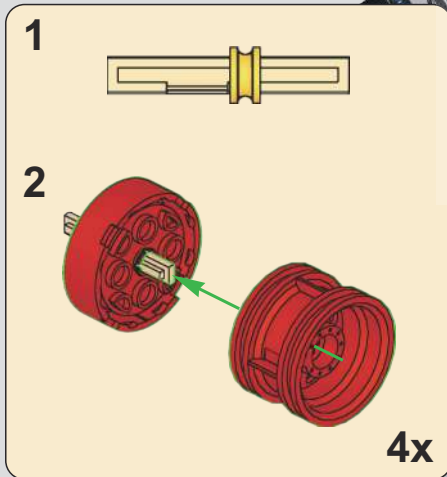
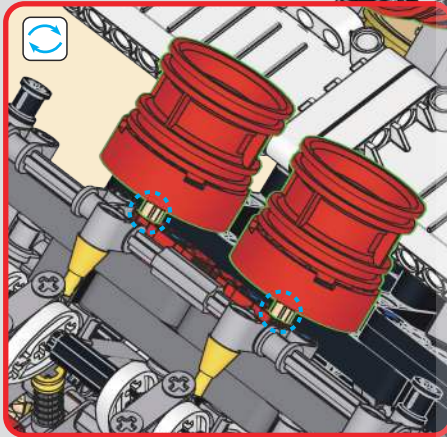

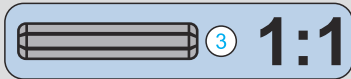
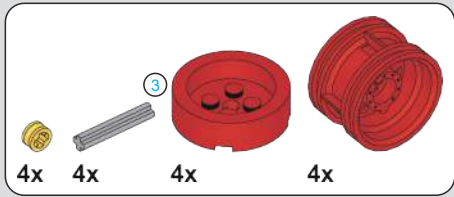

402

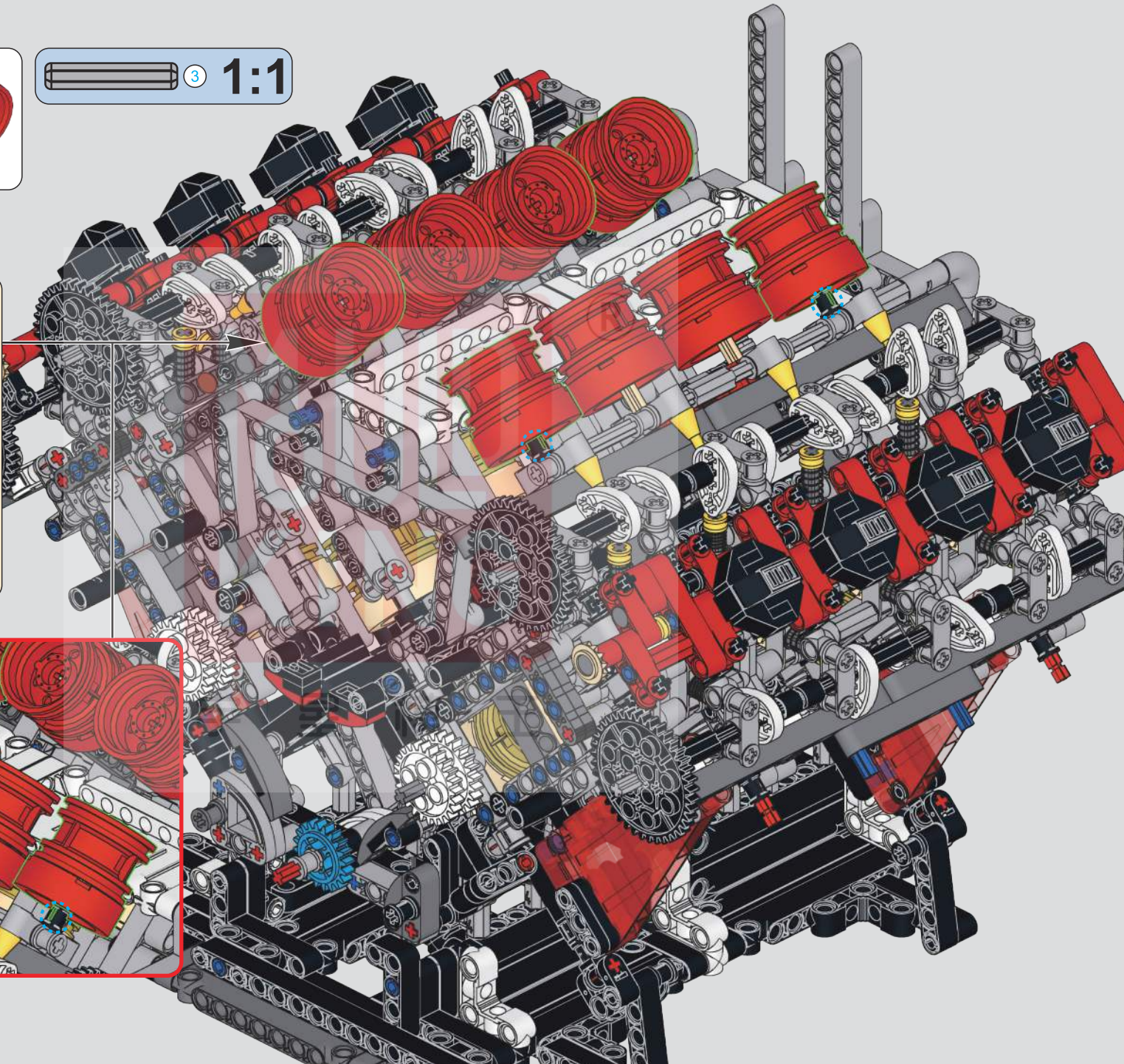
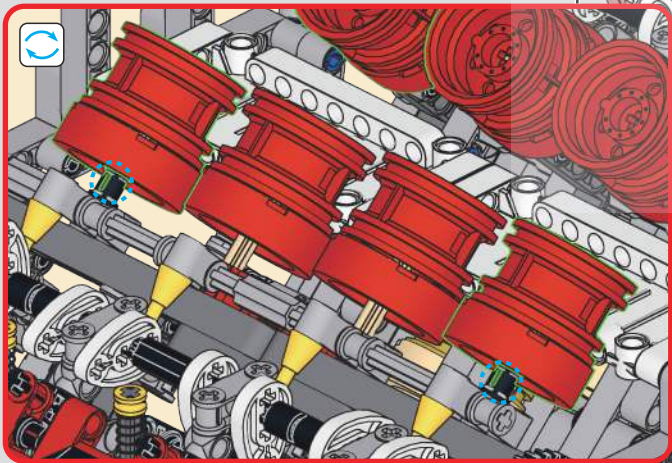
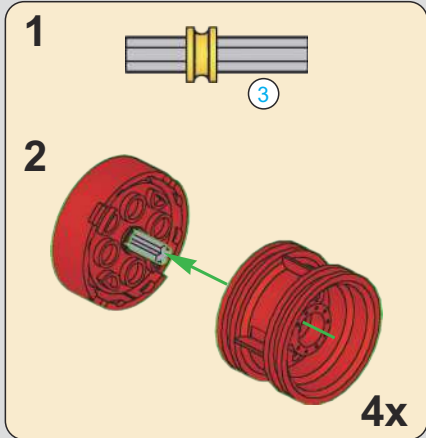

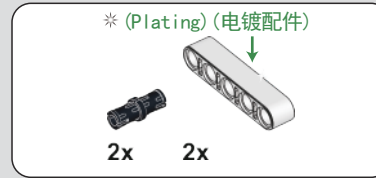
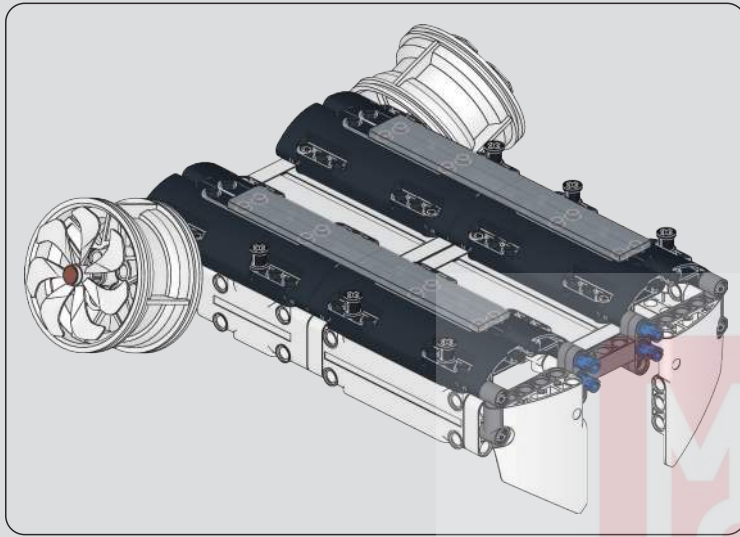

403

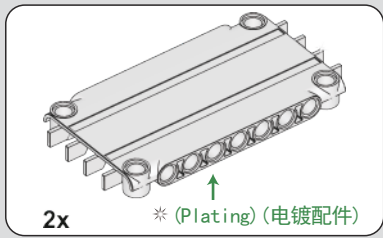
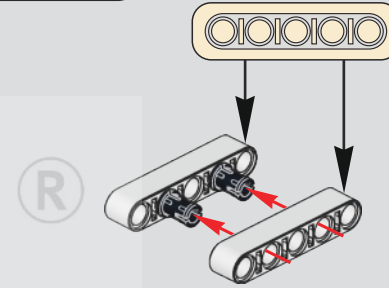

404

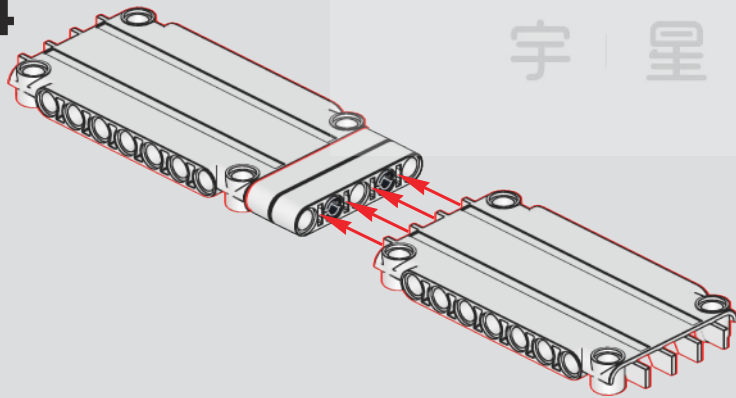

405

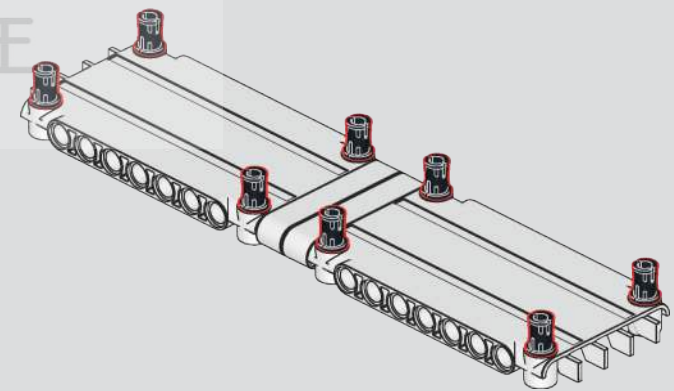

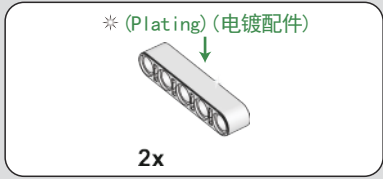

406

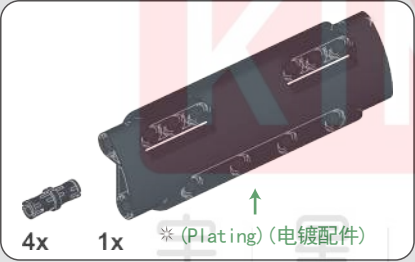
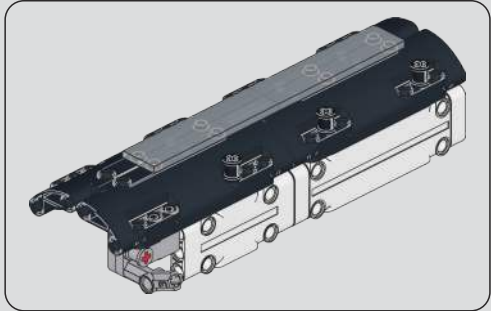
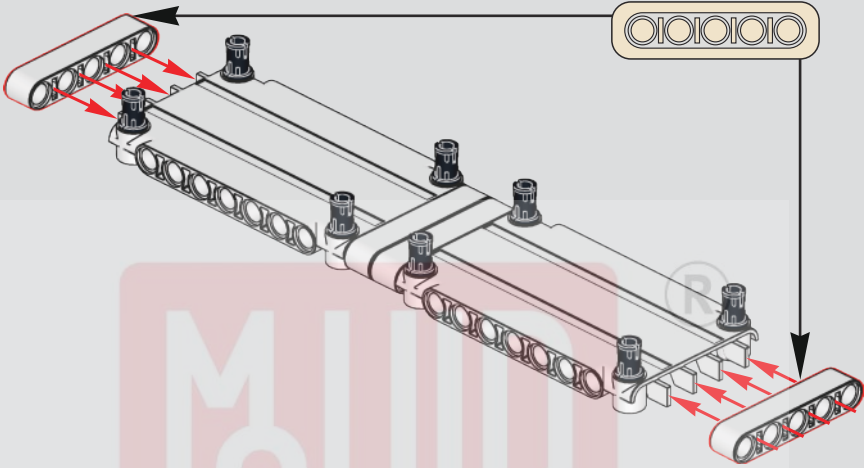

407

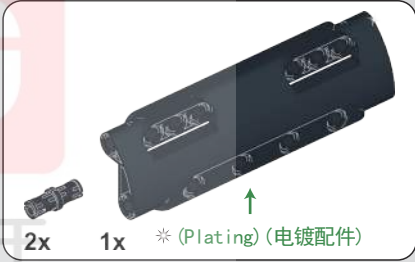

408

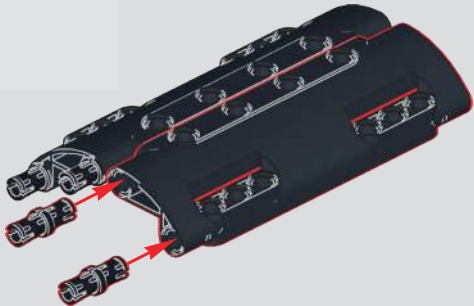



409

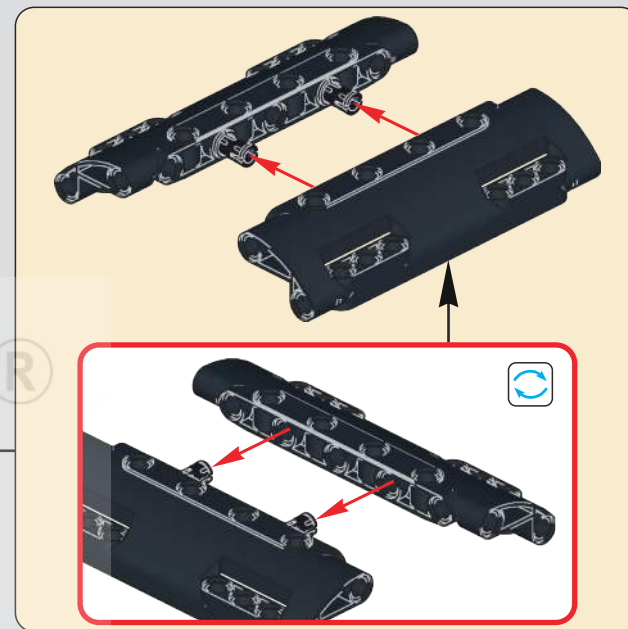
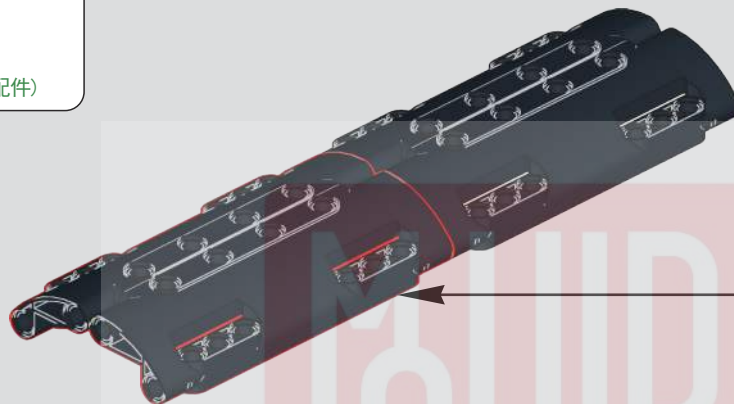

410

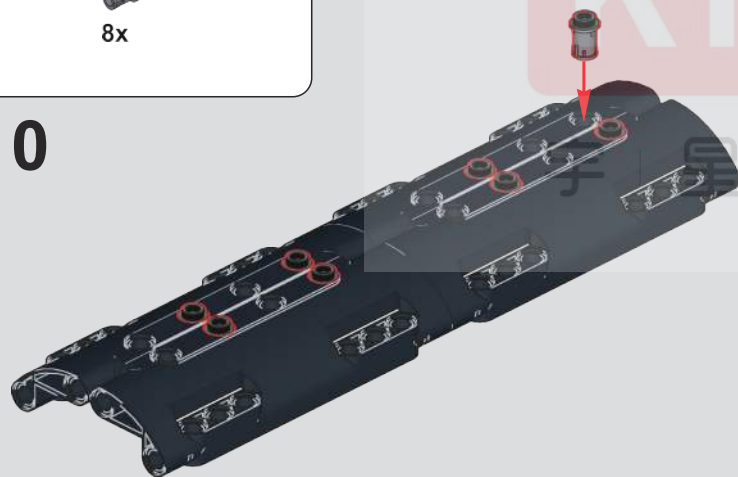

411

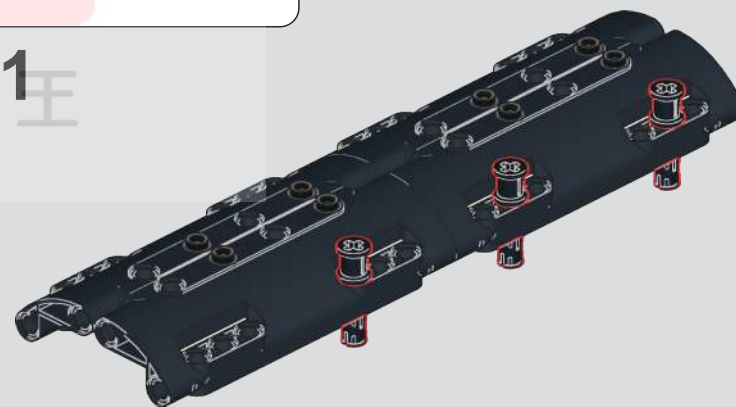

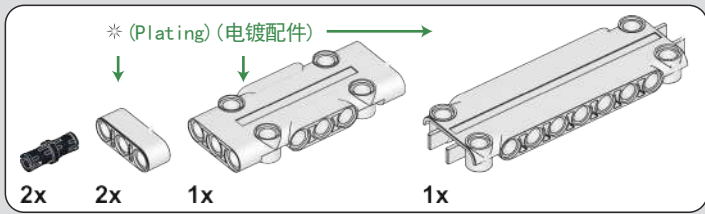

412

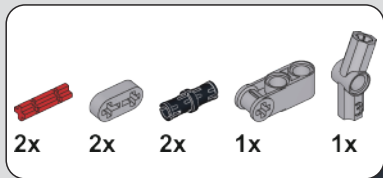
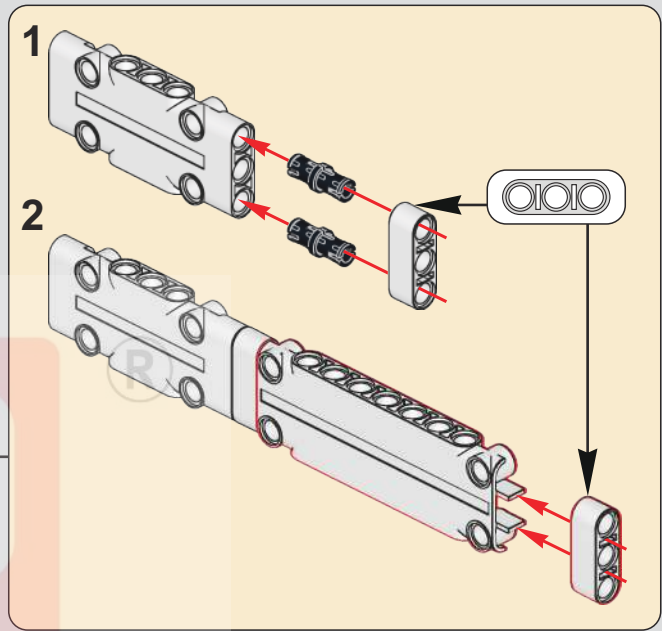
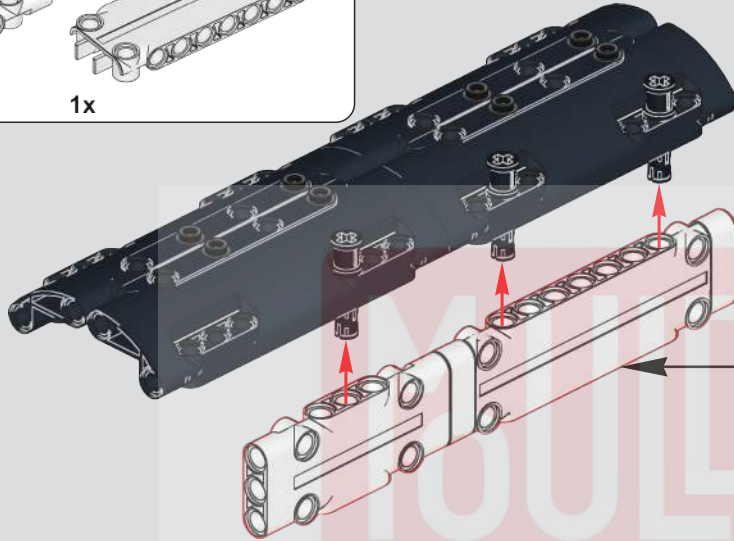
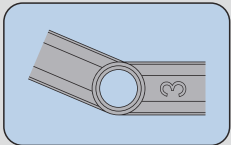

413

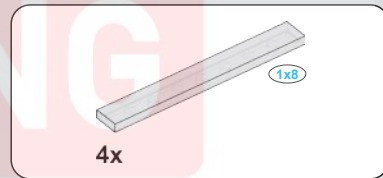
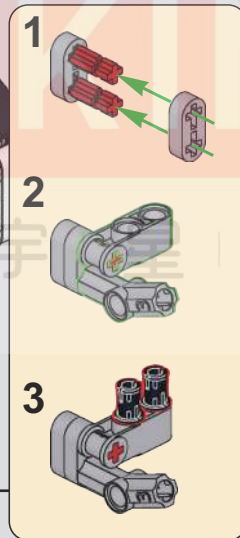
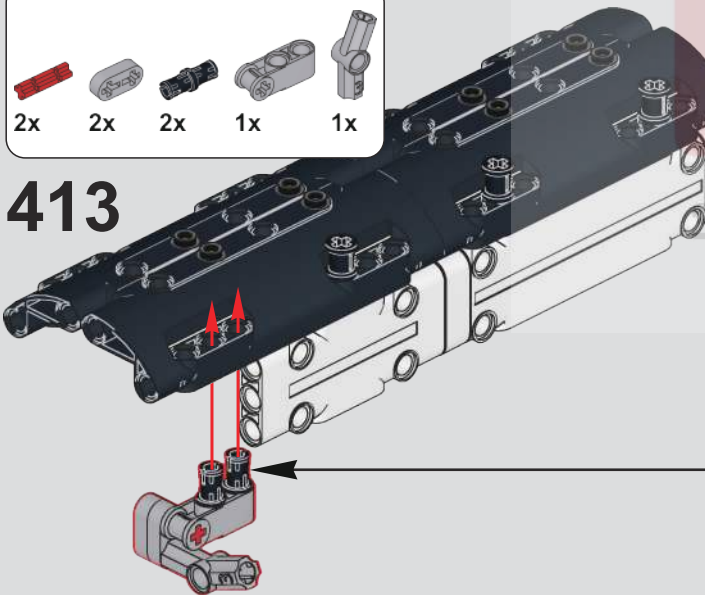

414

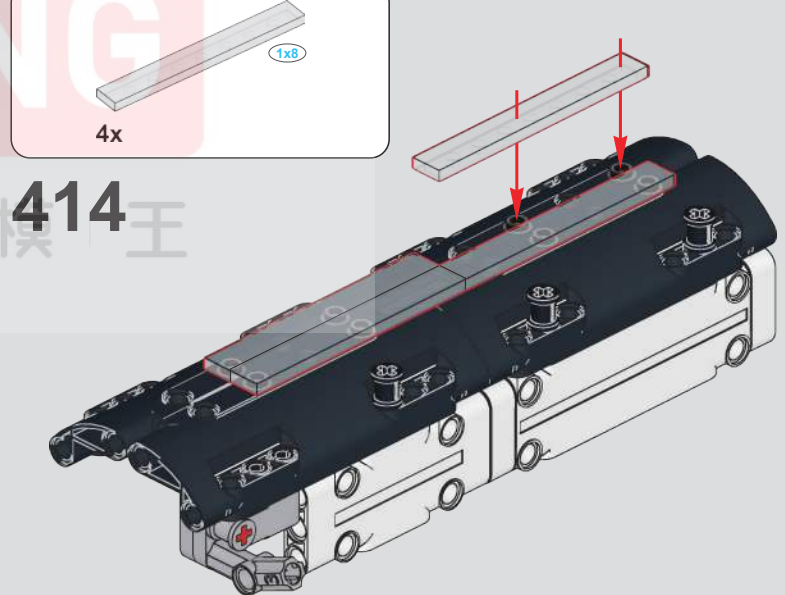

415

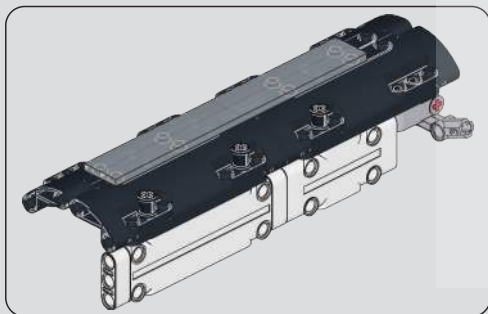
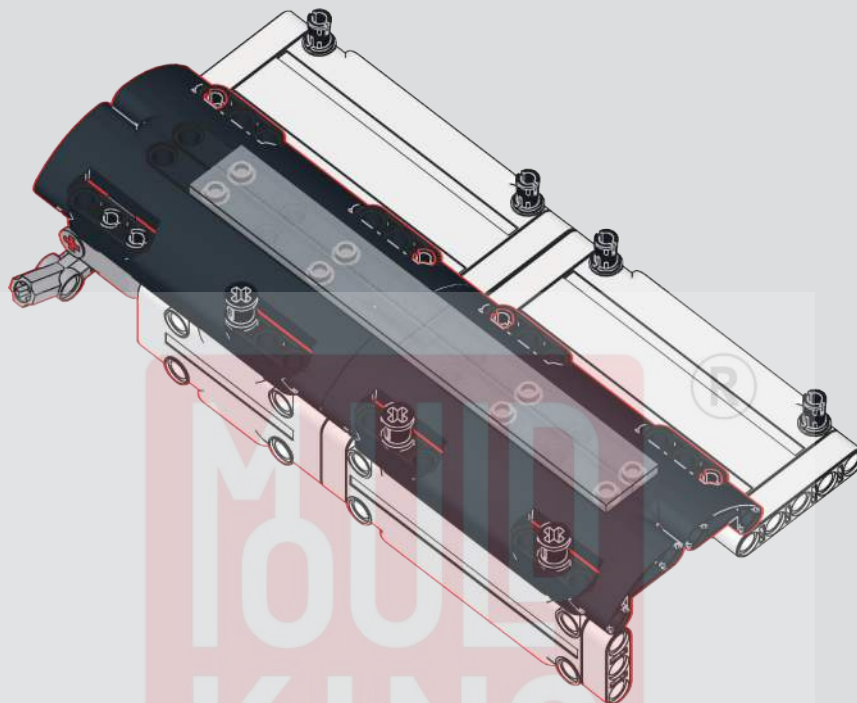

416



417

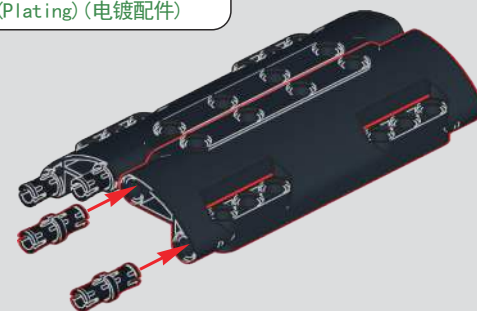

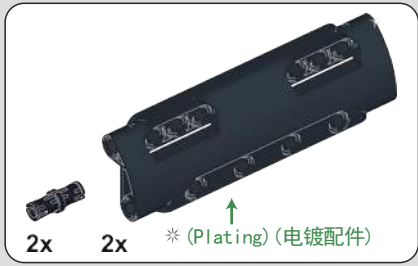

418

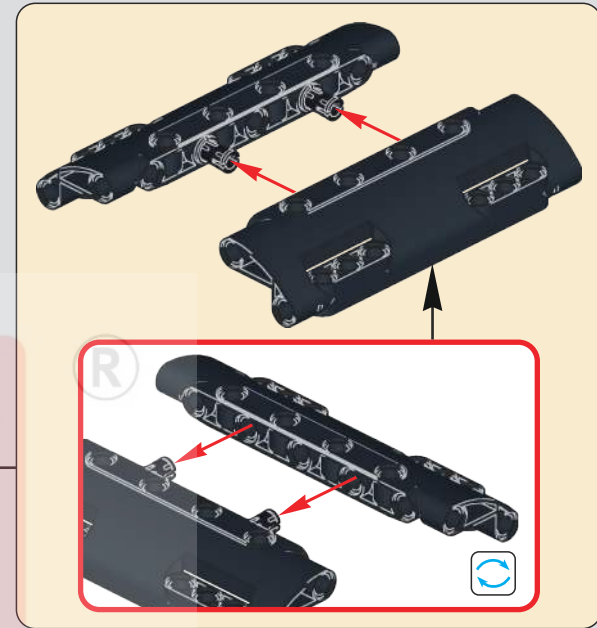
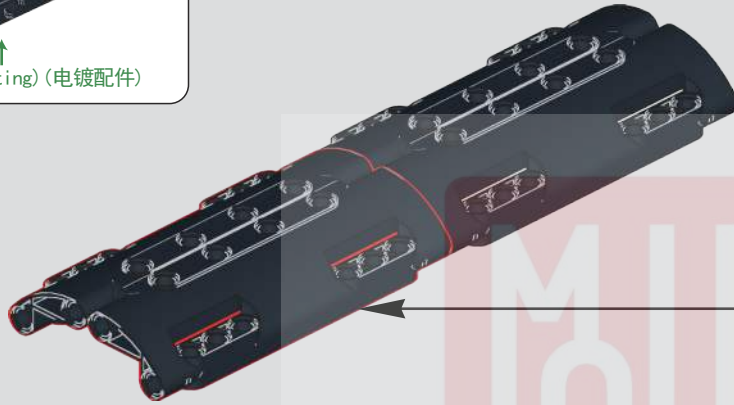

419

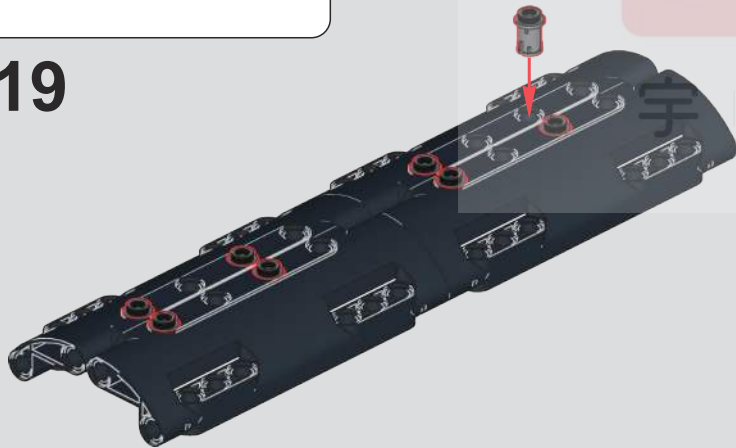

420

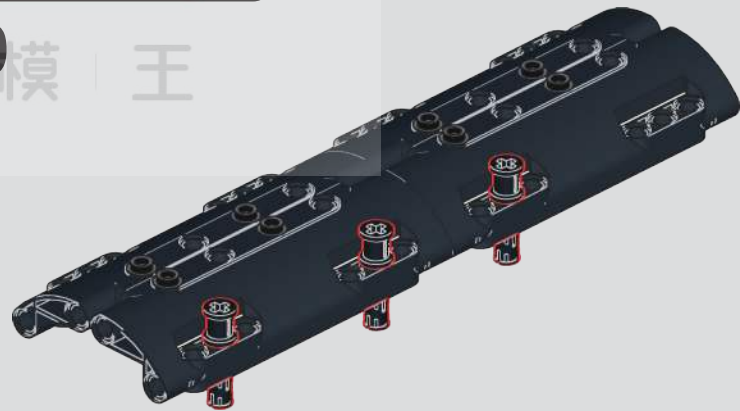

MOLD KING
宇星模王

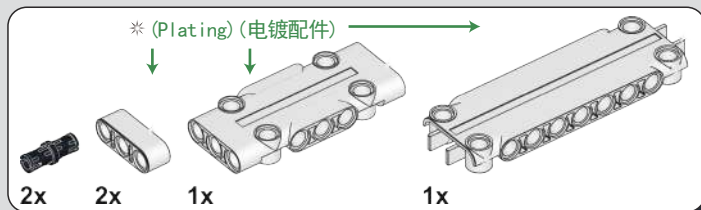

421

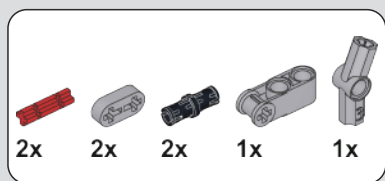
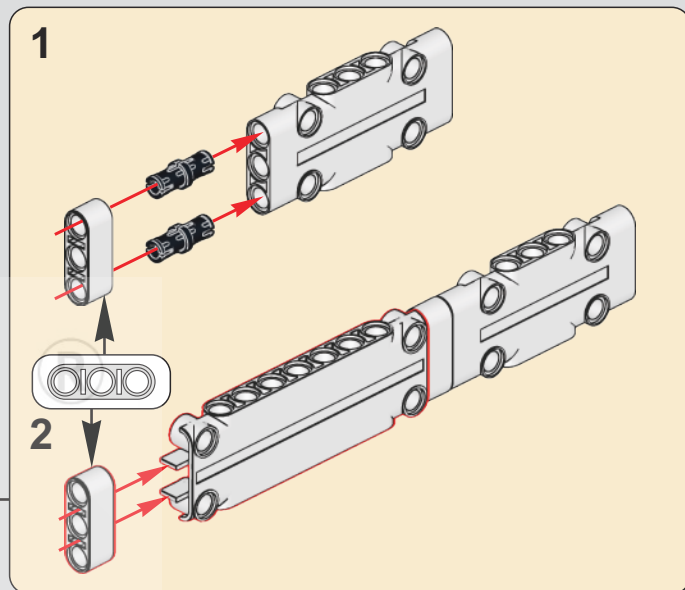
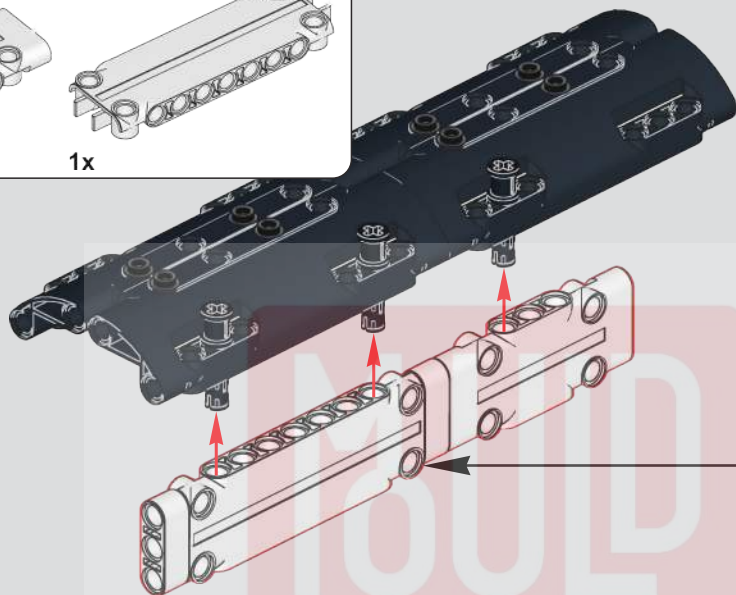
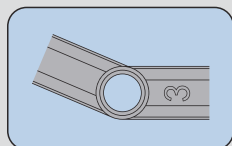

422

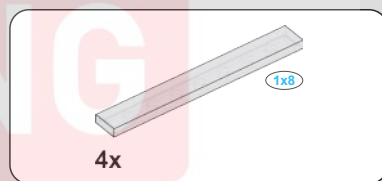
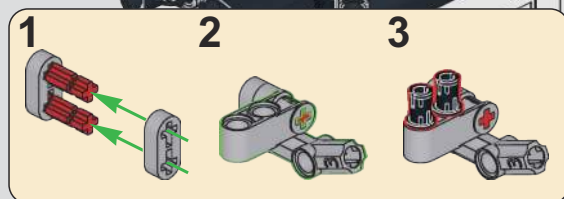
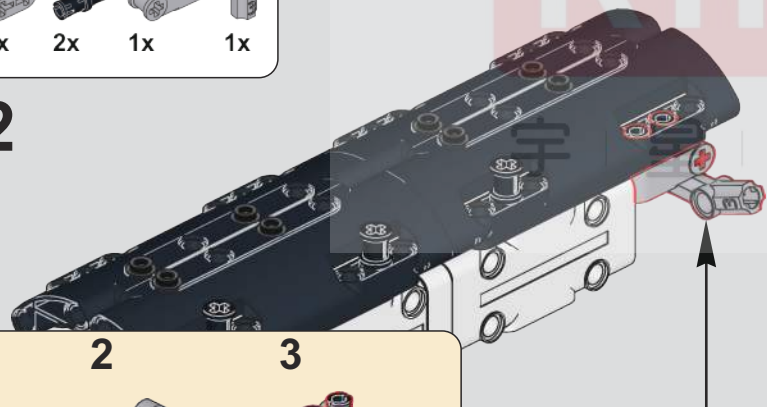

423

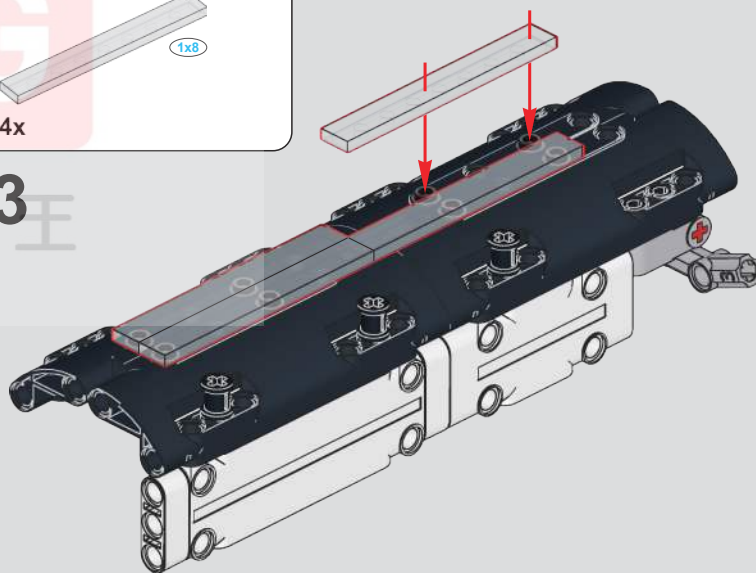

424

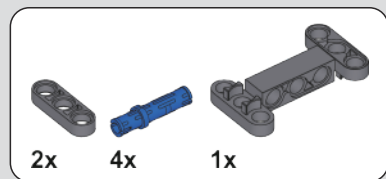
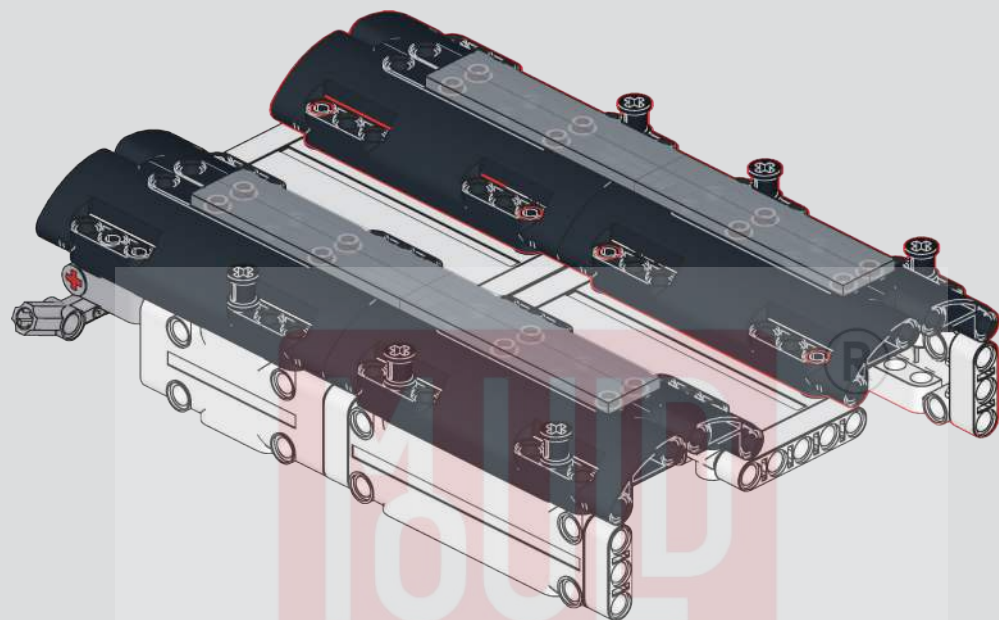

425

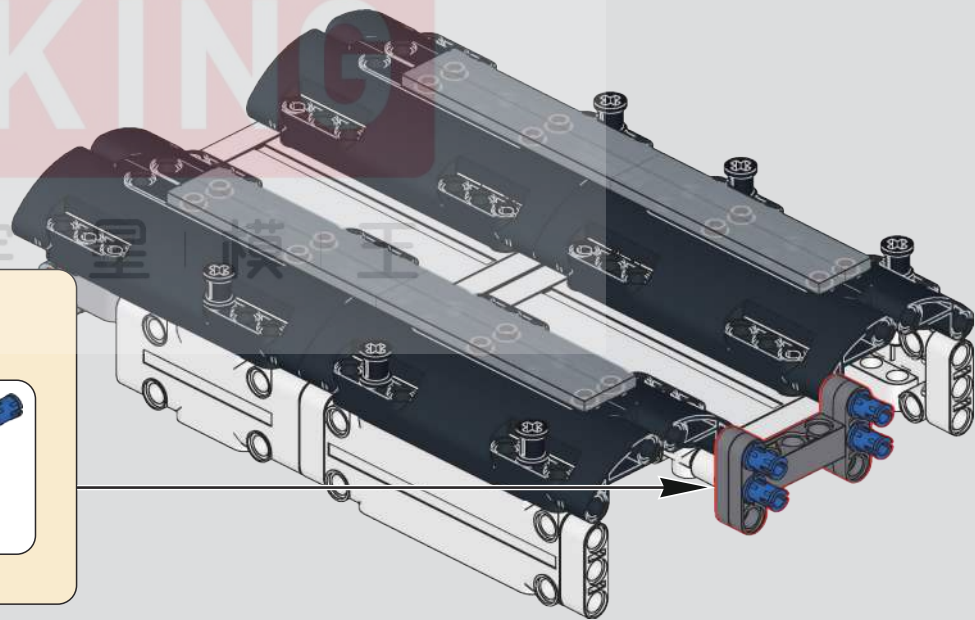
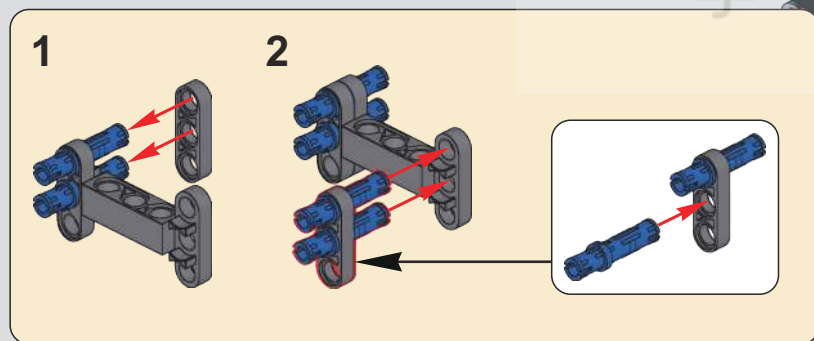

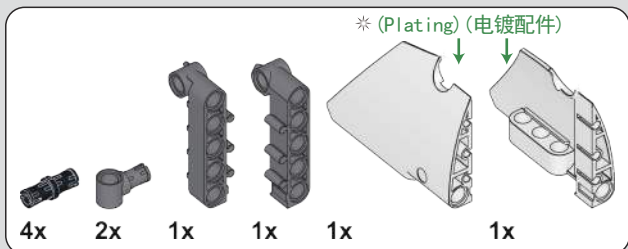

426

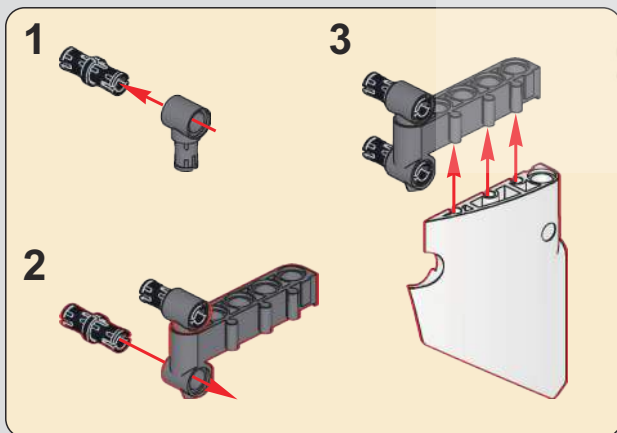
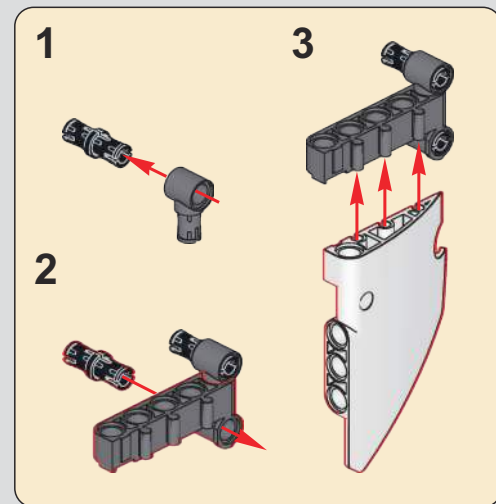
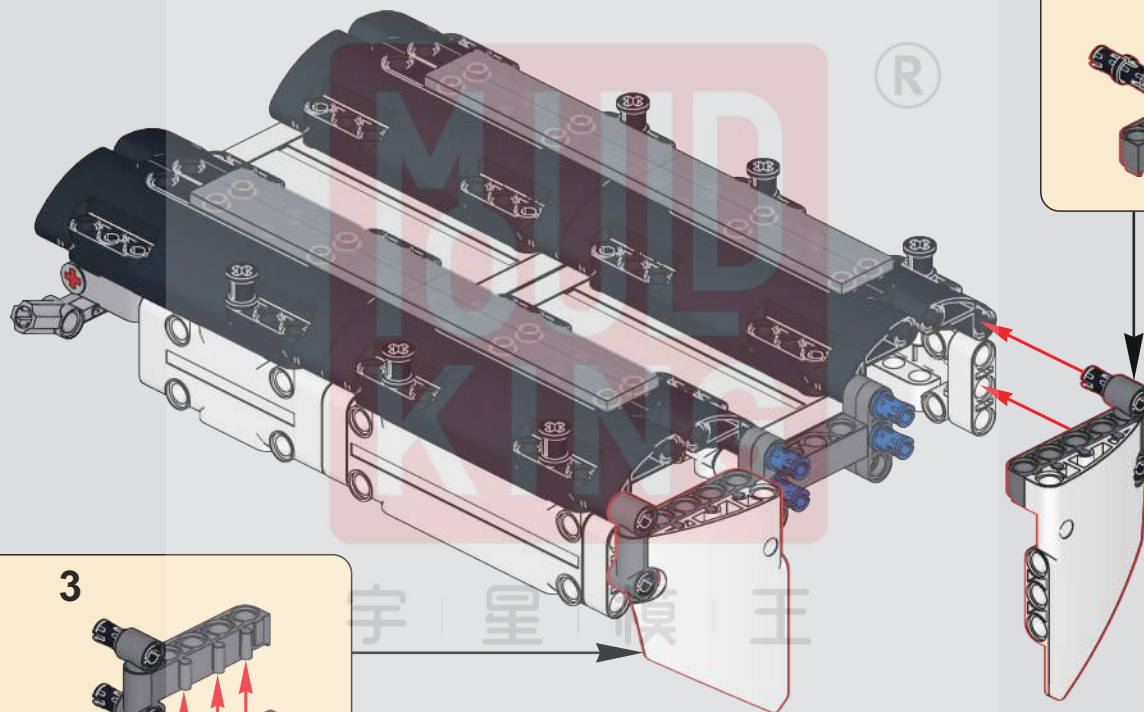

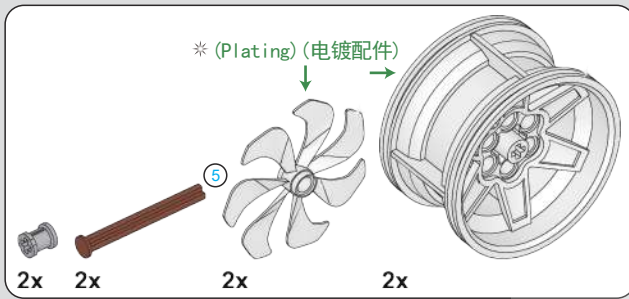

427

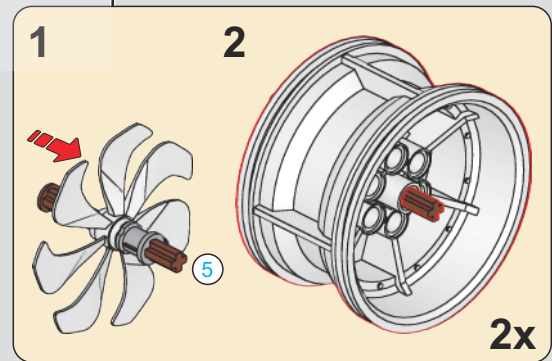
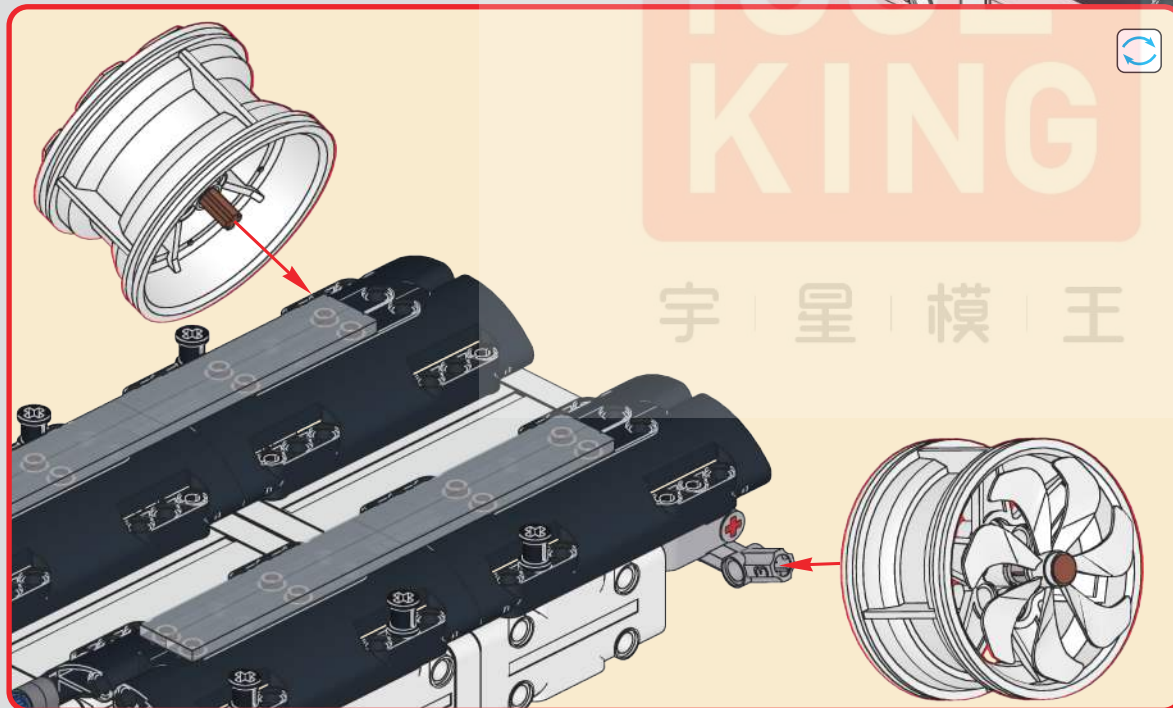
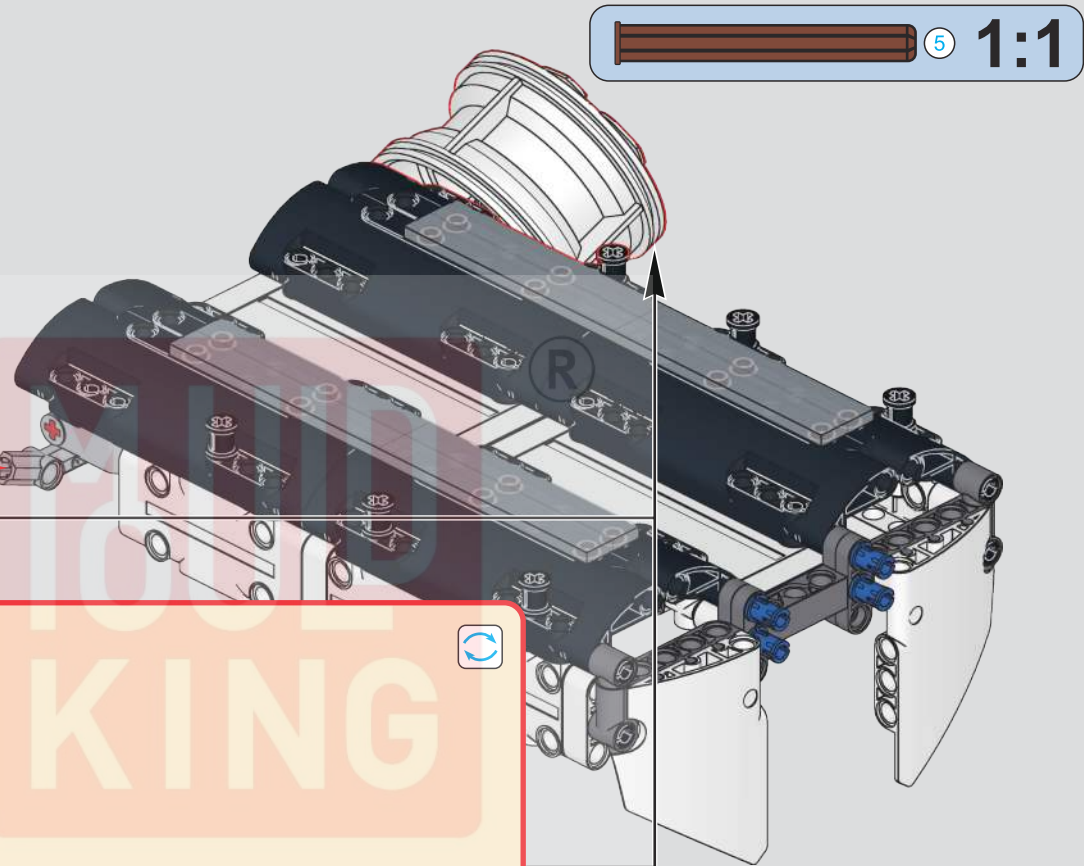
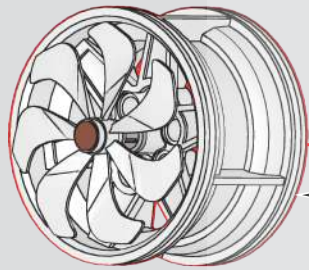

428

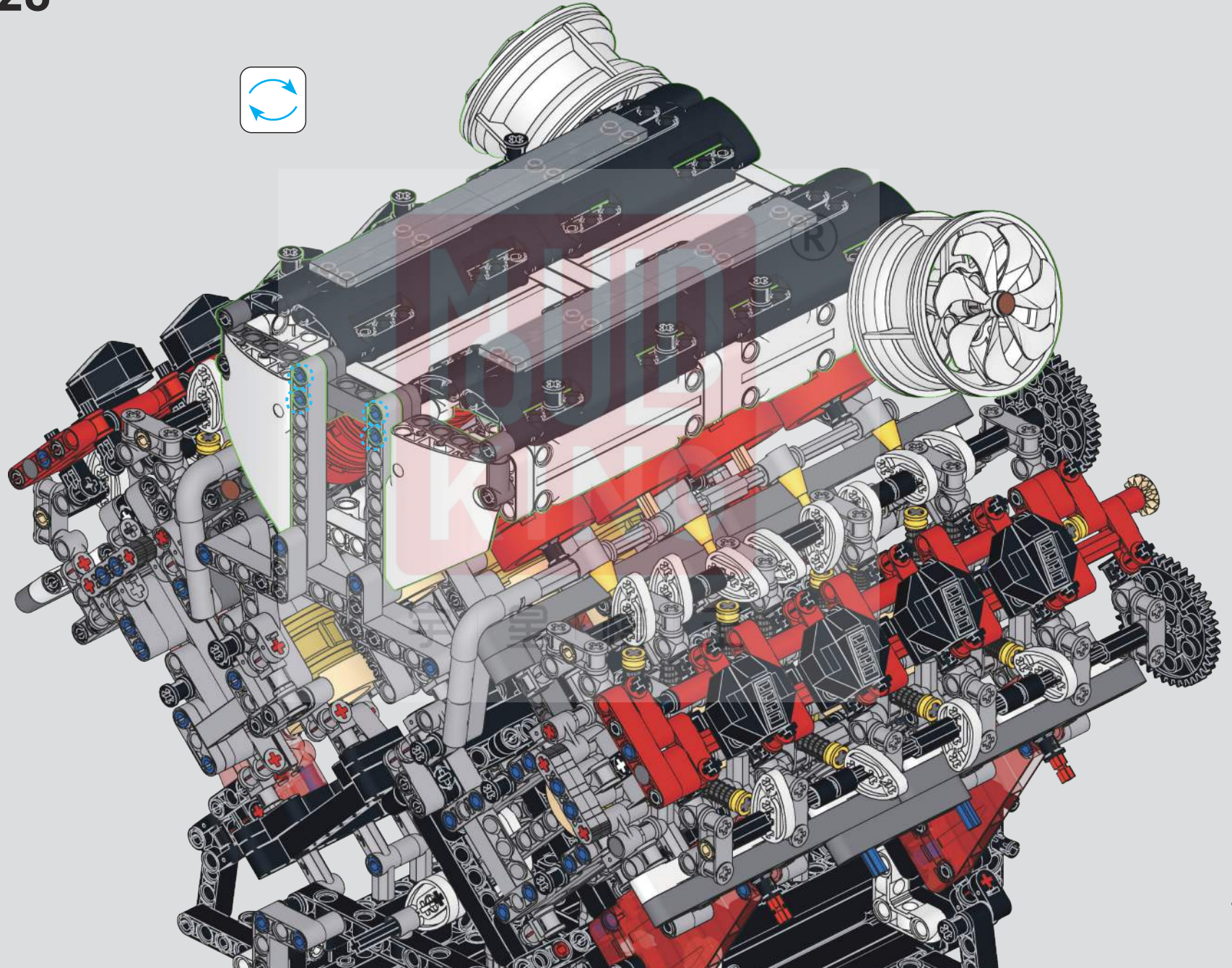

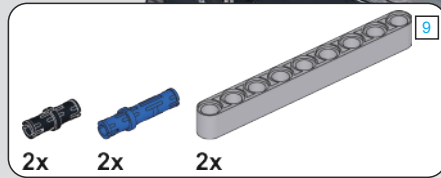

429

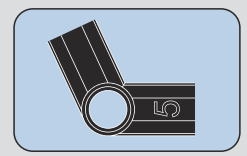
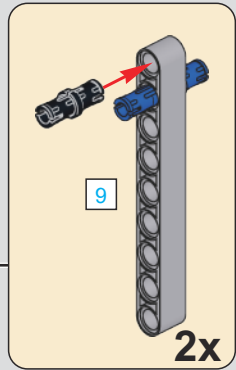

430

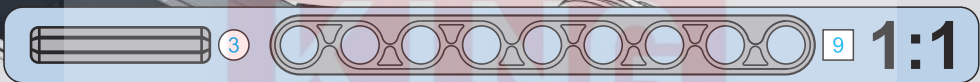

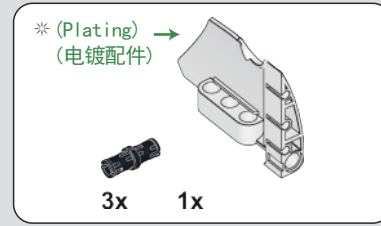
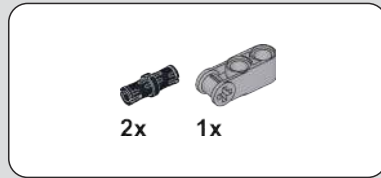
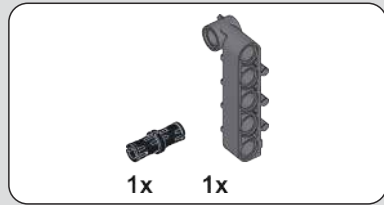

431

432

433

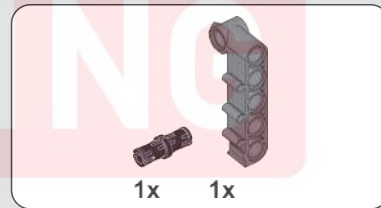
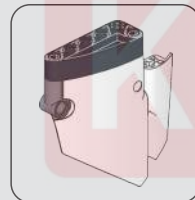
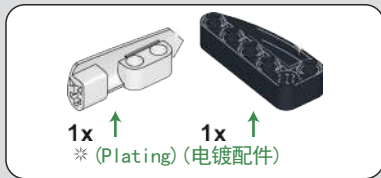
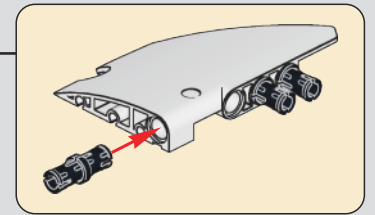
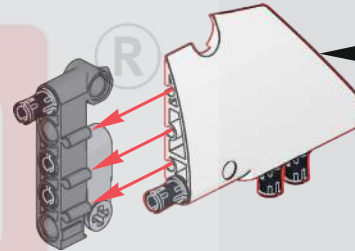
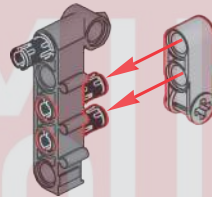
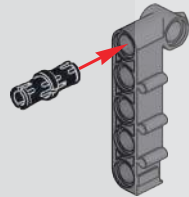

434

435

436

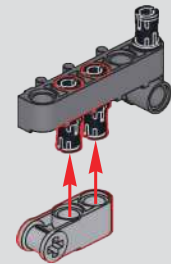
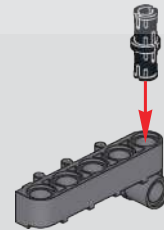
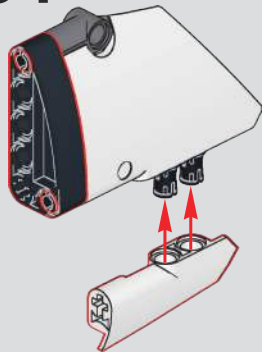

* (Plating) (电镀配件) →

3x 1x

437



1x 1x

* (Plating) (电镀配件)

438

439

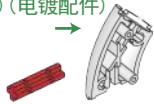
* (Plating) (电镀配件)

 8x 32x

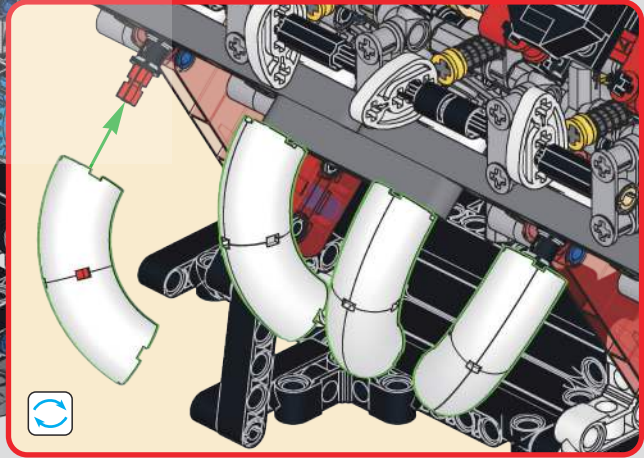
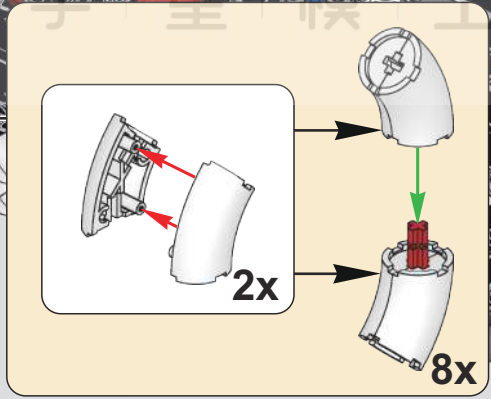
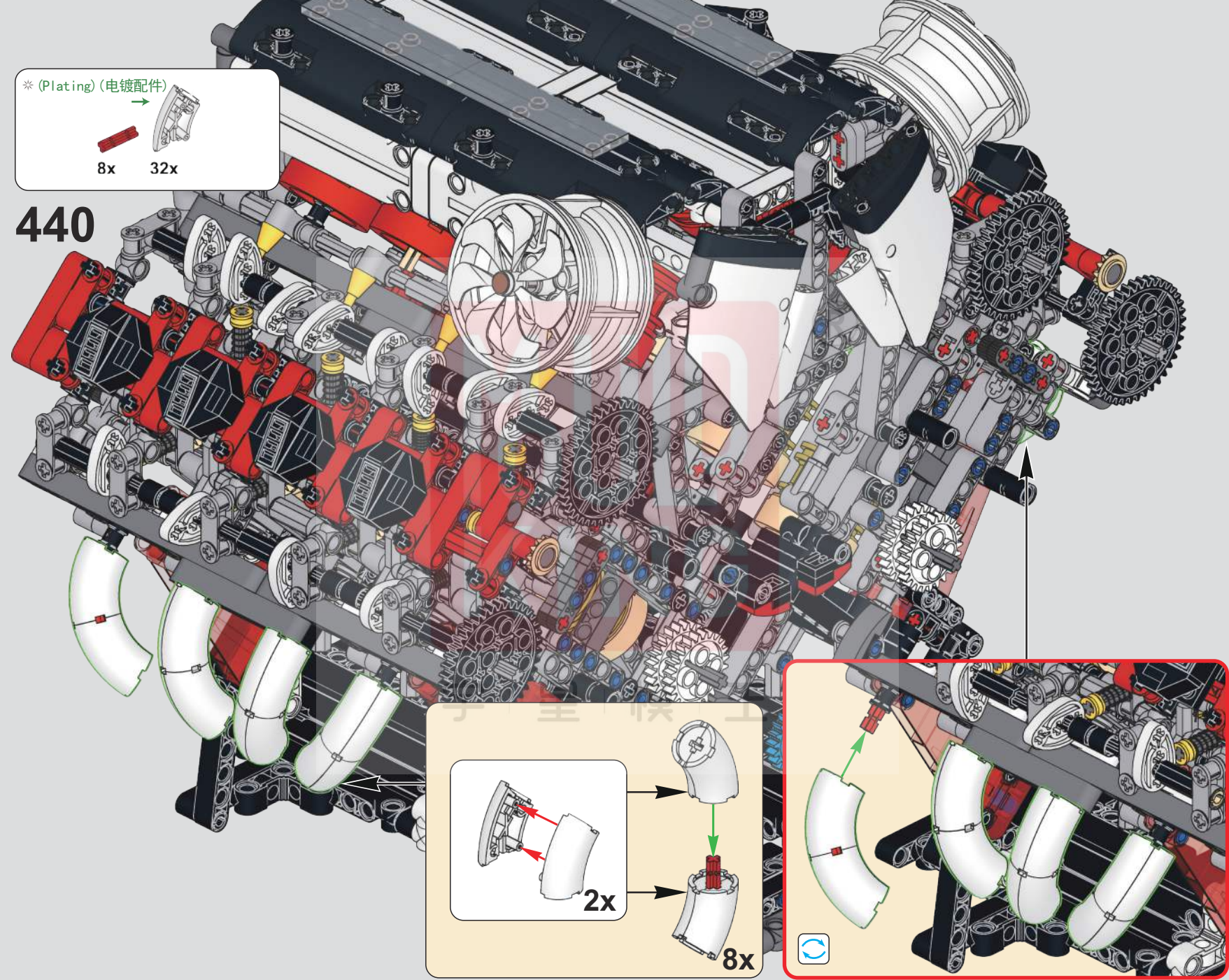
440





51x

441

如图所示蓝色线框部分可以调节链条松紧。

The blue outlined area shown in the diagram can be adjusted to tighten or loosen the chain.

Der im Diagramm dargestellte, blau umrandete Bereich kann genutzt werden, um die Kettenspannung zu erhöhen oder zu verringern.

La partie encadrée en bleu sur le schéma peut être ajustée pour resserrer ou desserrer la chaîne.

L'area contornata in blu mostrata nel diagramma può essere regolata per stringere o allentare la catena.

El área delimitada en azul en el diagrama puede ajustarse para apretar o aflojar la cadena.

図示された青色の枠線部分でチェーンの張りを調整できます。

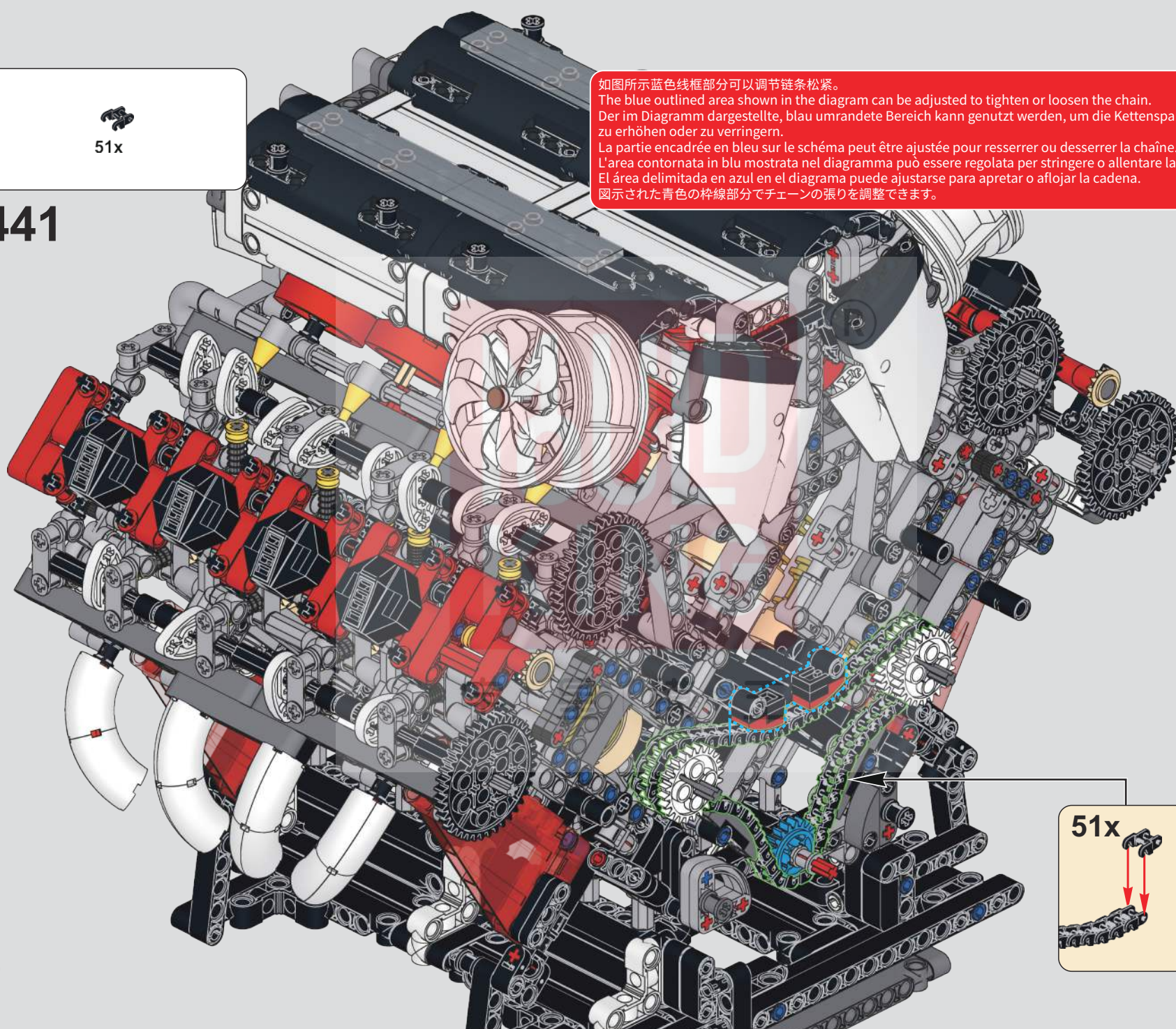

51x

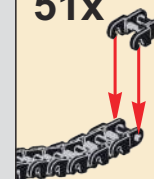

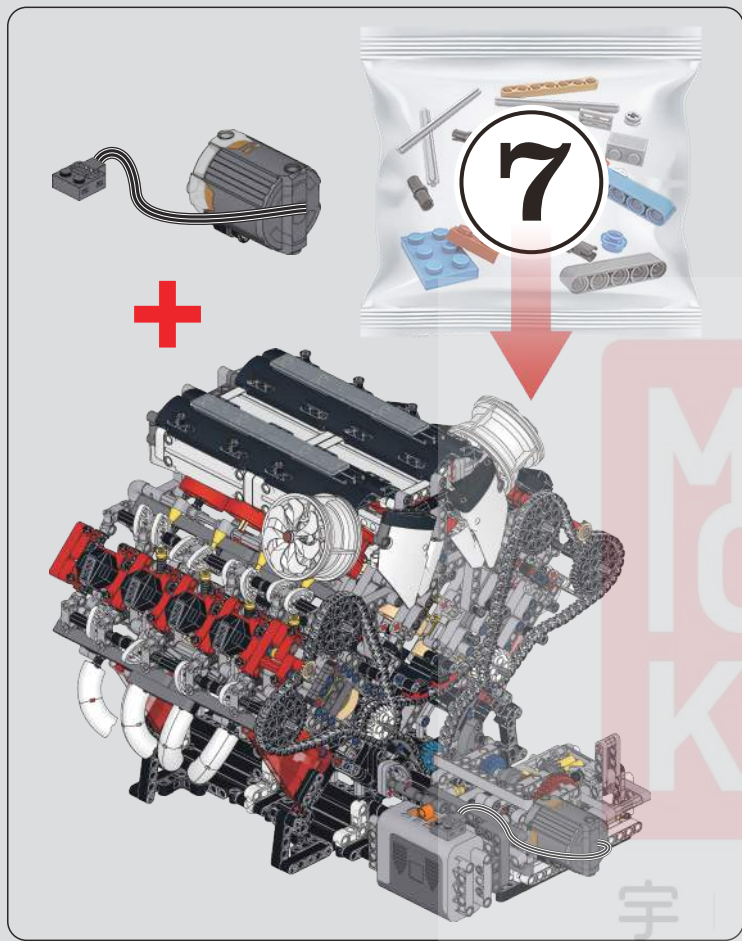

120x

442

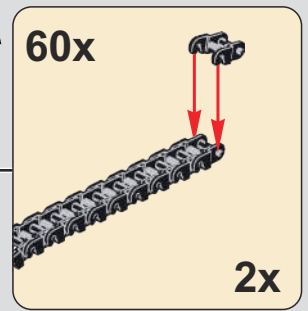
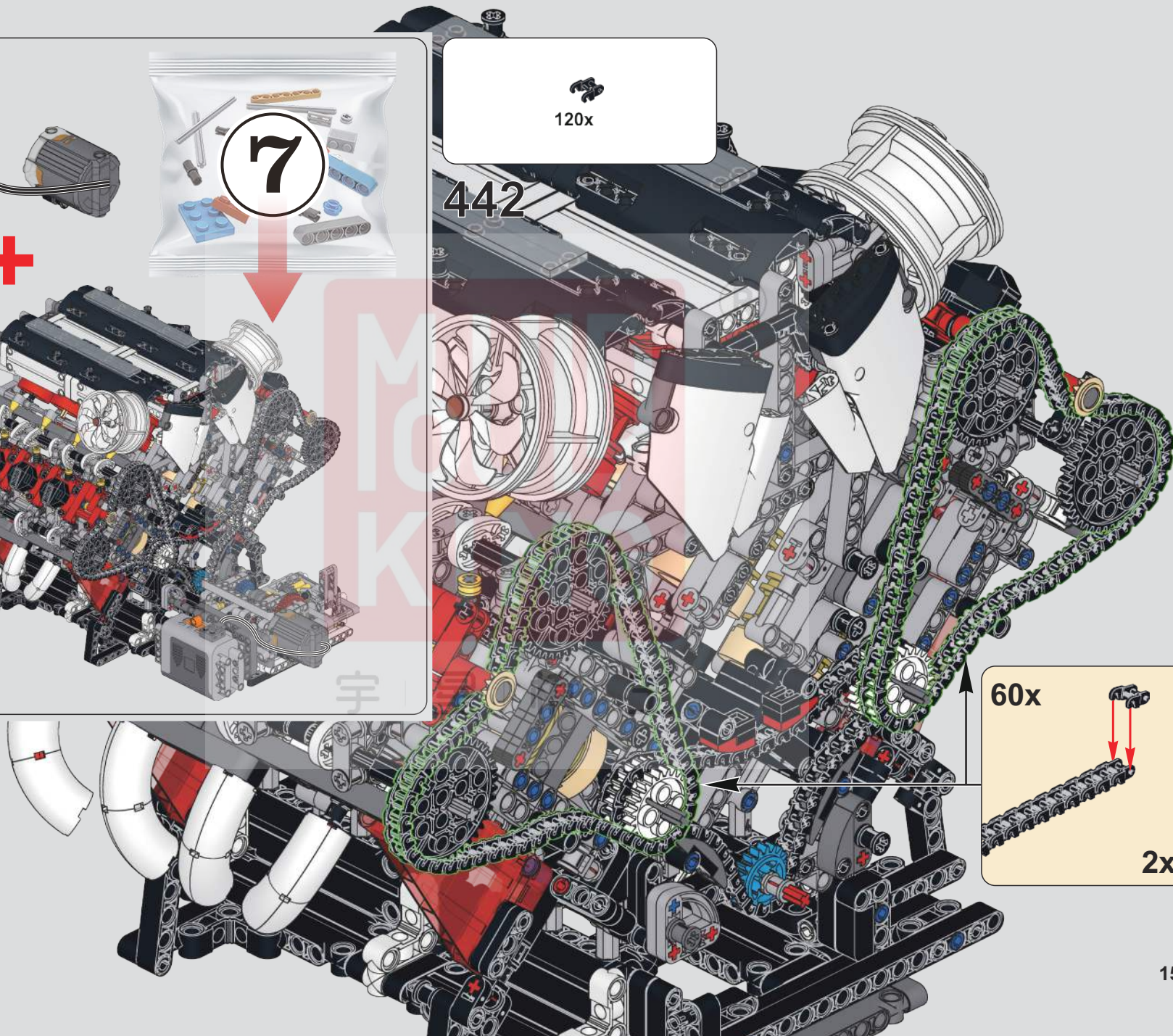



 1x 1x 1x

443

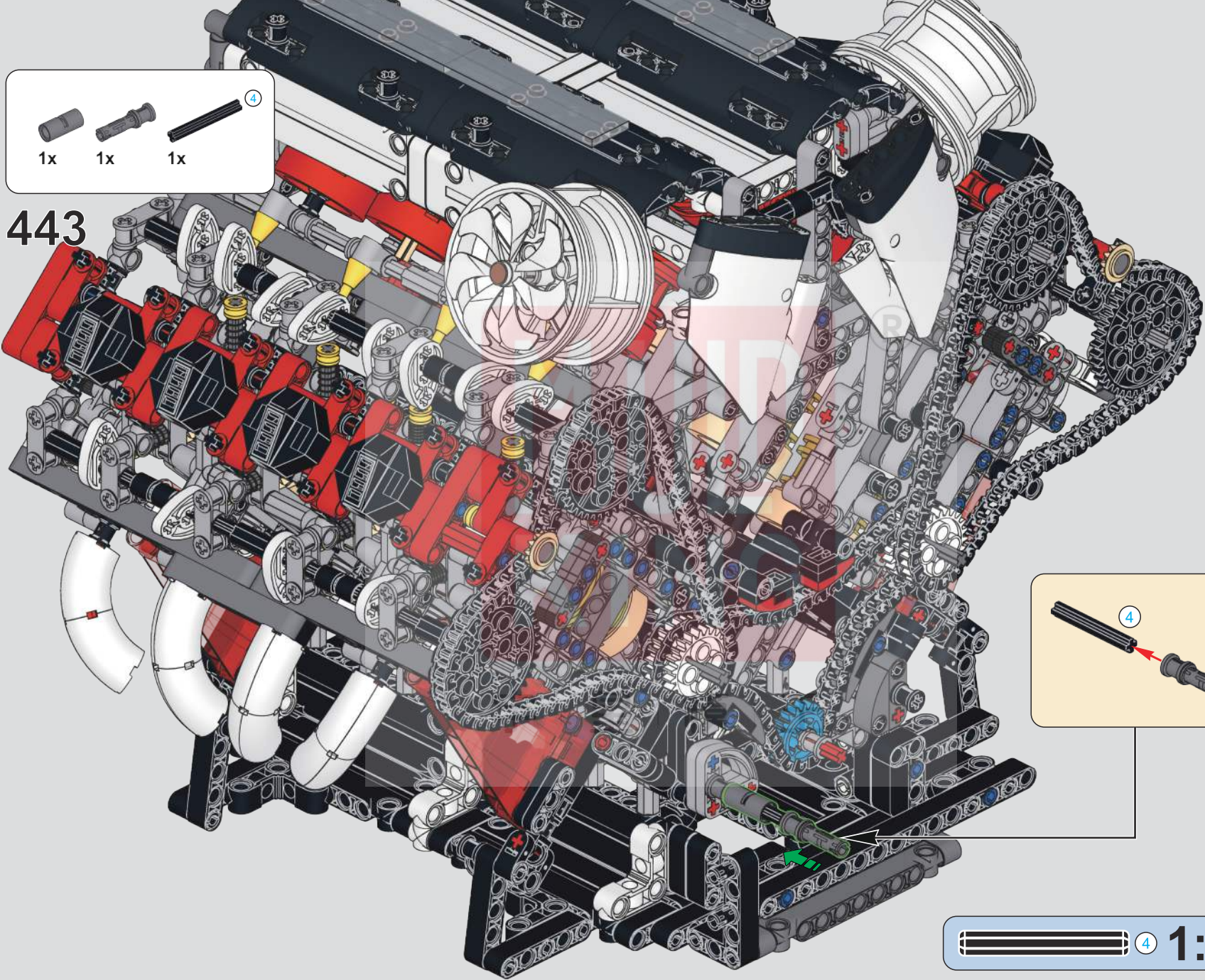

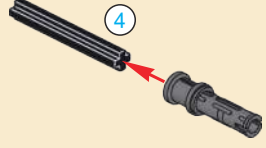

 4



 4 1:1

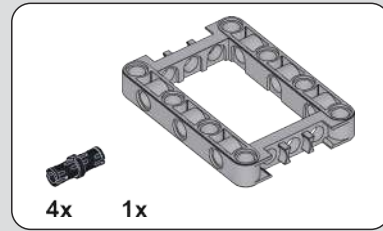
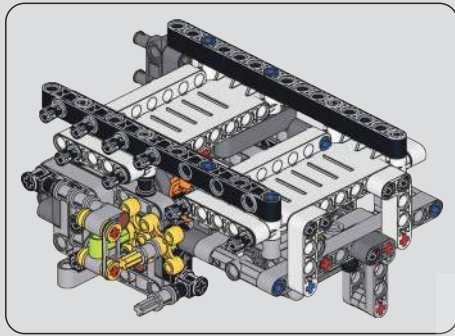

444

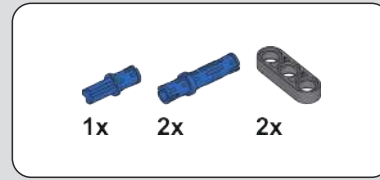

445

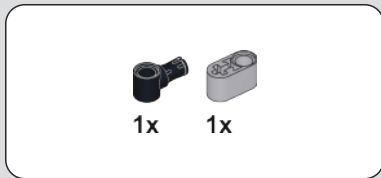
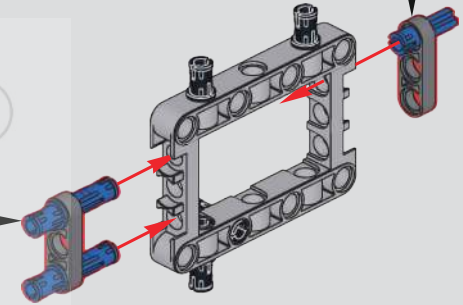
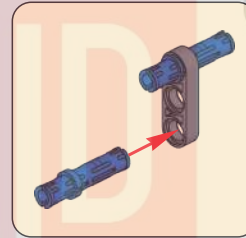
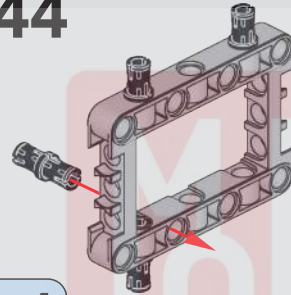
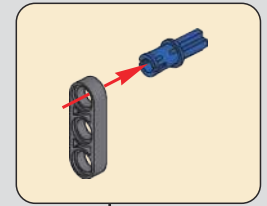

446

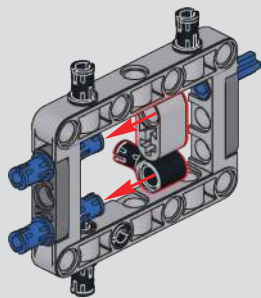

447

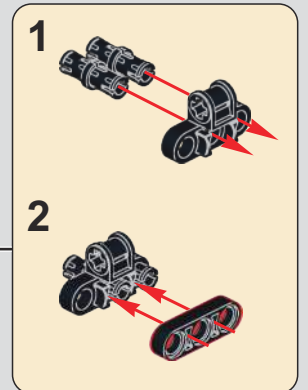
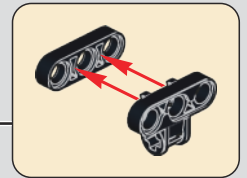
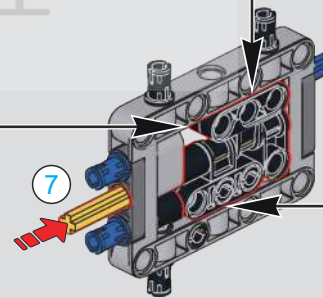
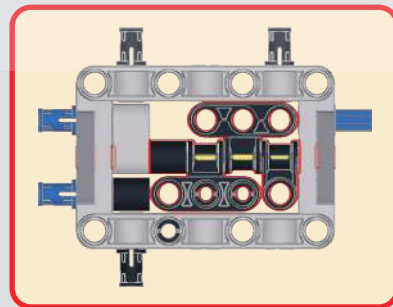

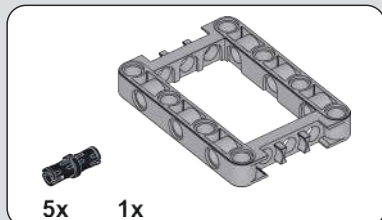
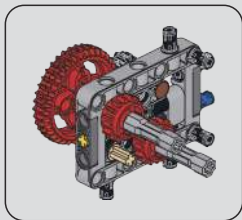

448

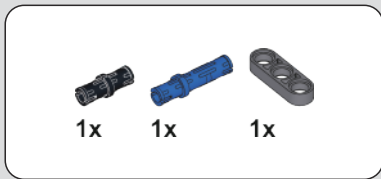
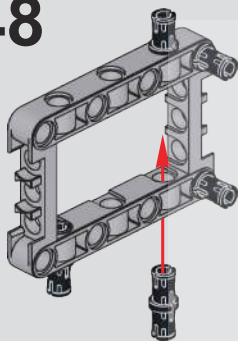

449

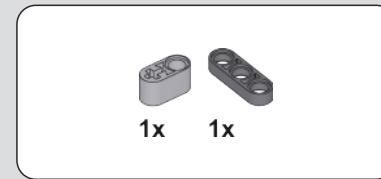
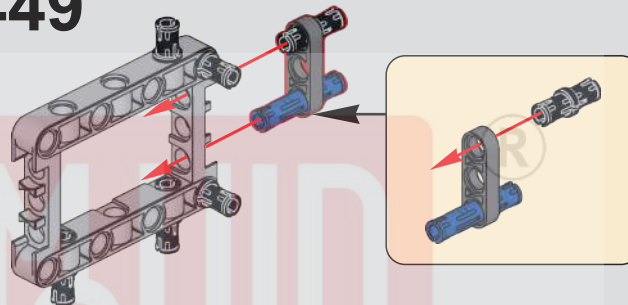

450

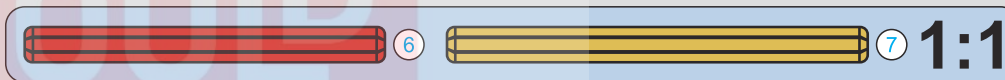
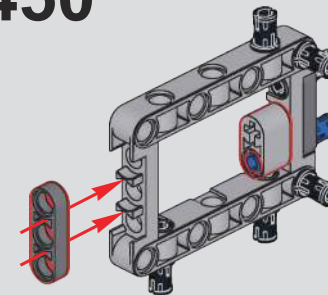

451

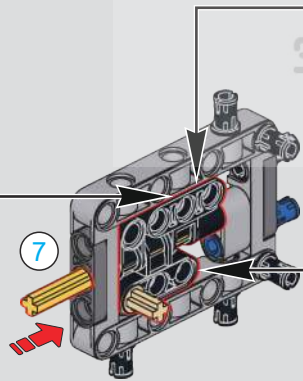
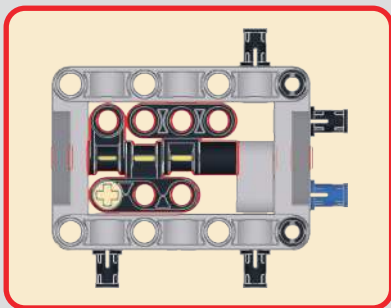

452

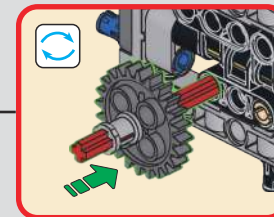
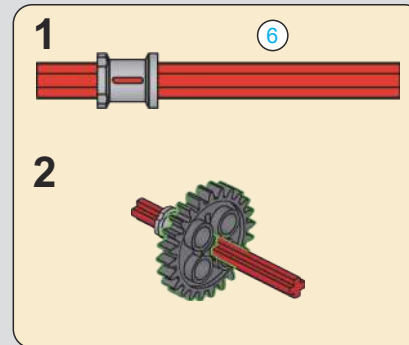
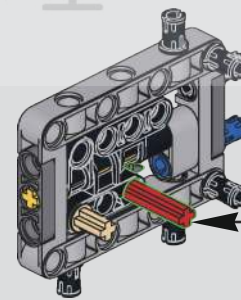
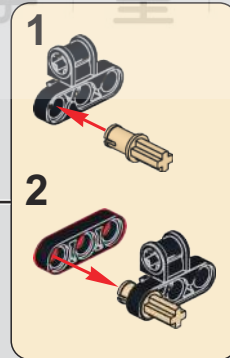

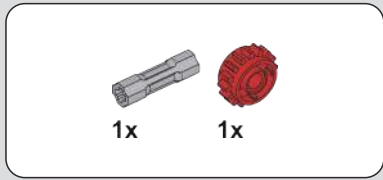

453

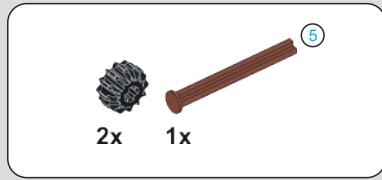
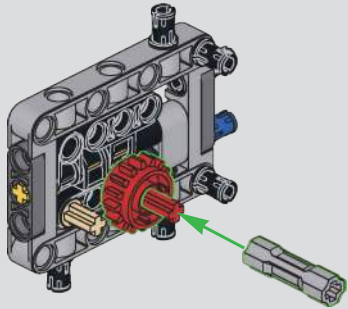

454

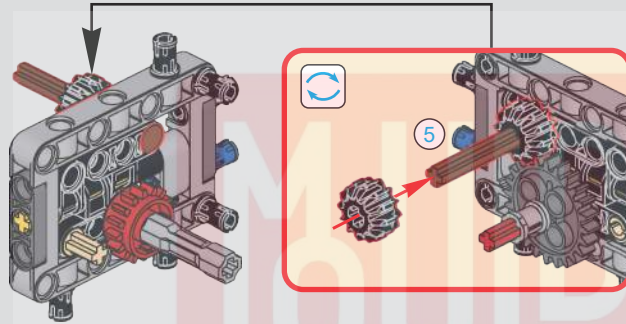

455

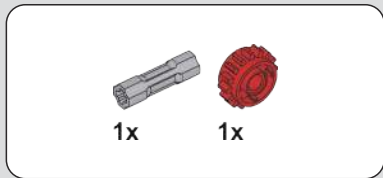
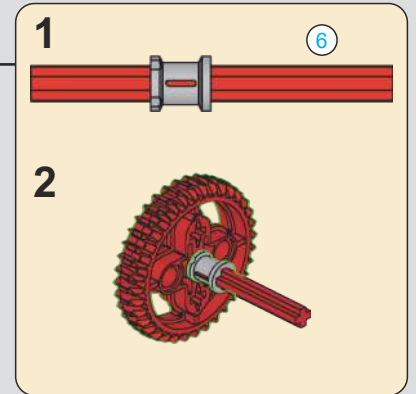
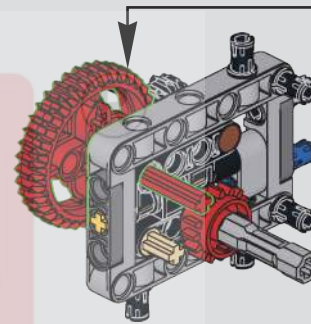

456

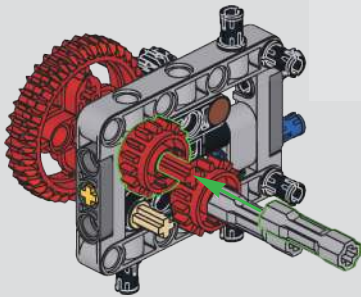

457

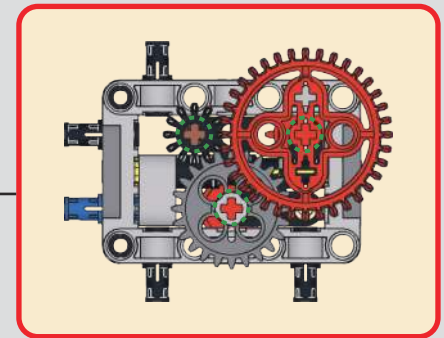
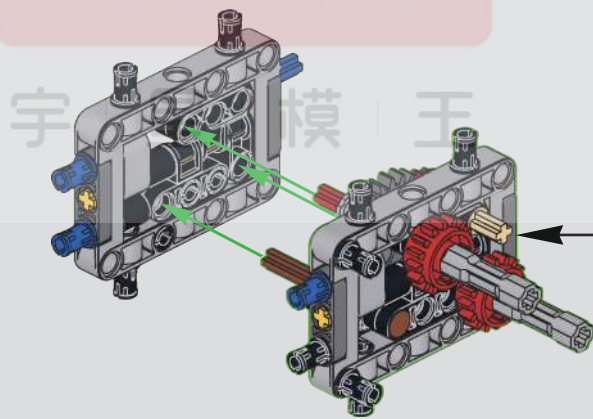



458

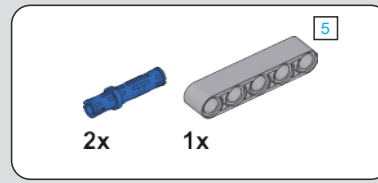
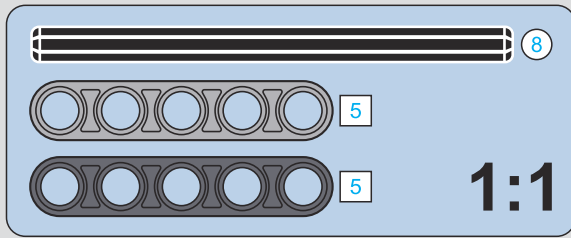

459

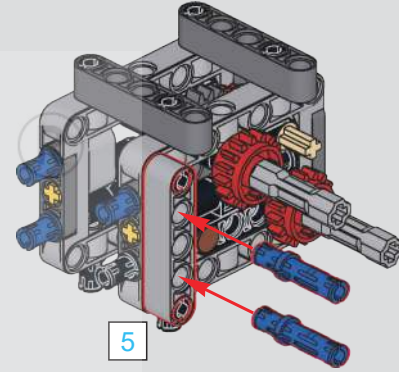
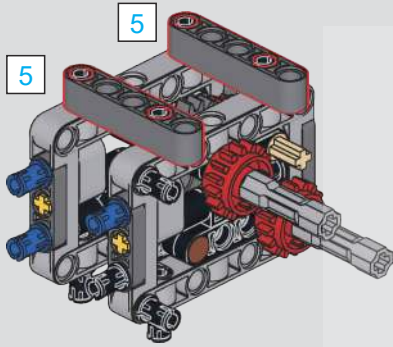

460

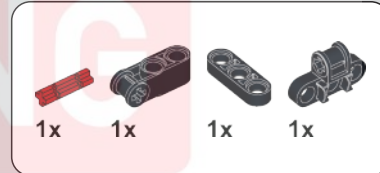
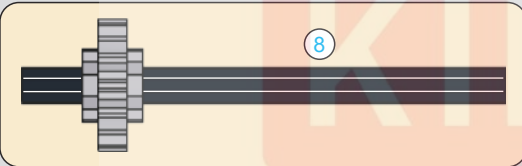

461

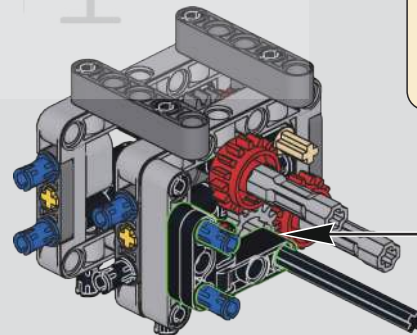
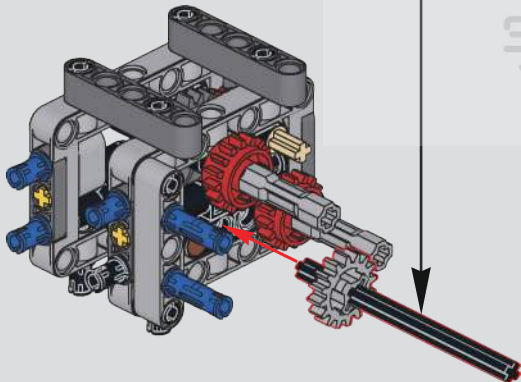
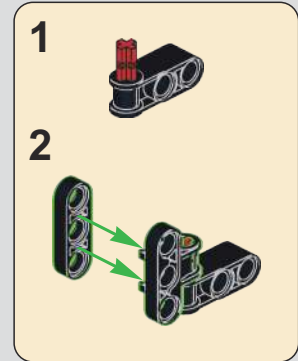



462

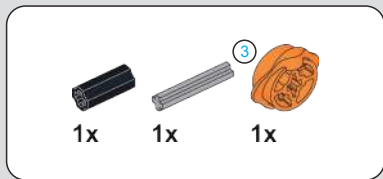
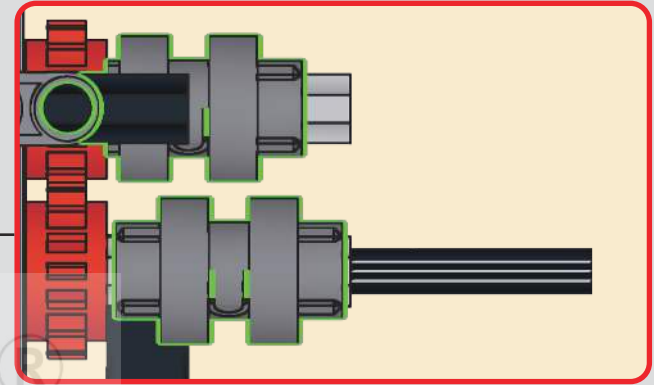
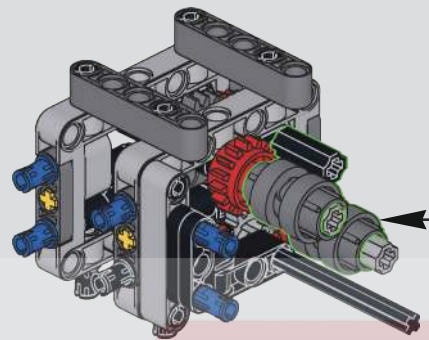

463

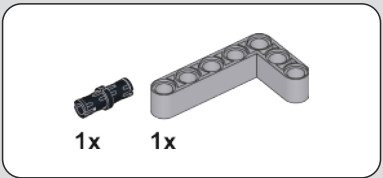
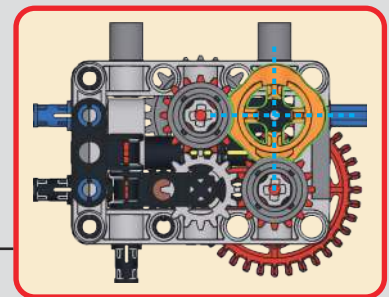
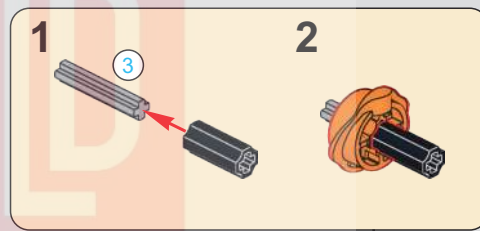
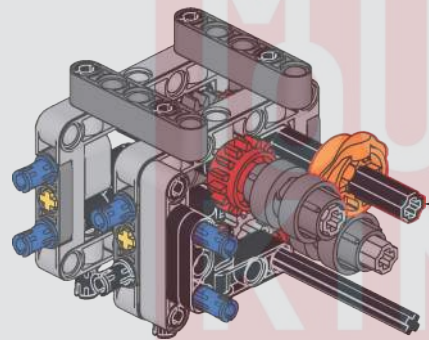

464

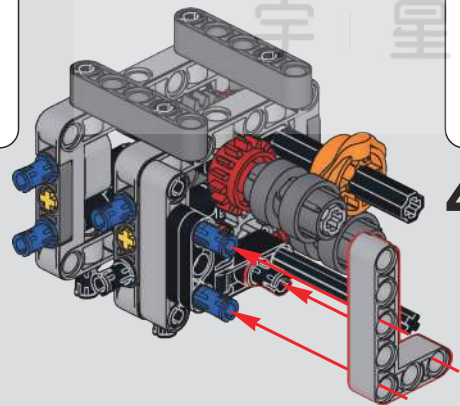

465

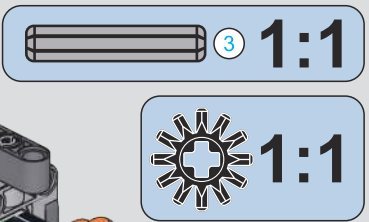
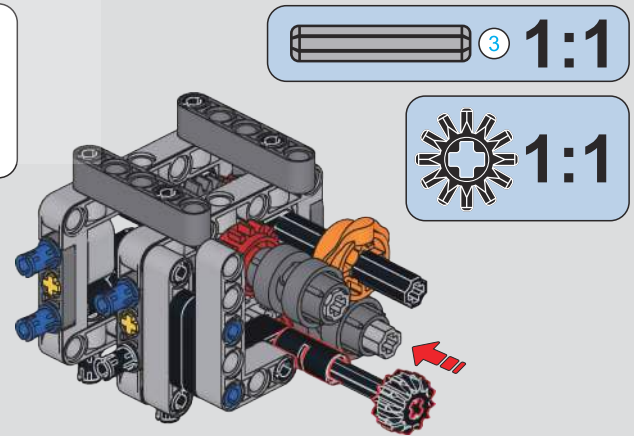

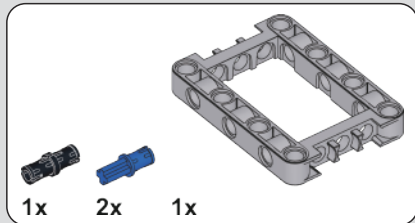
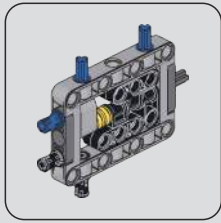

466

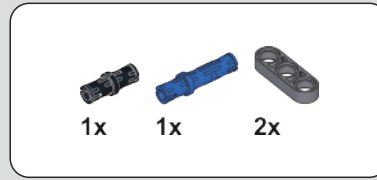
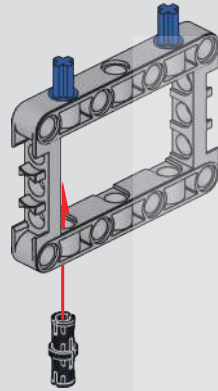

467

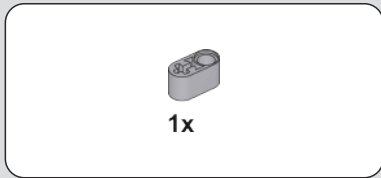
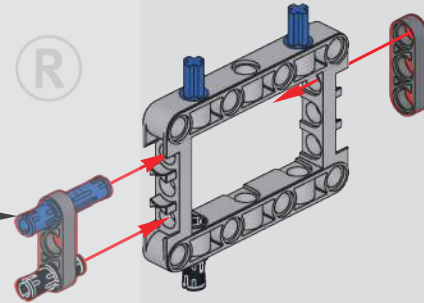
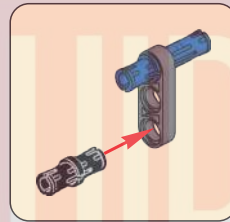

468

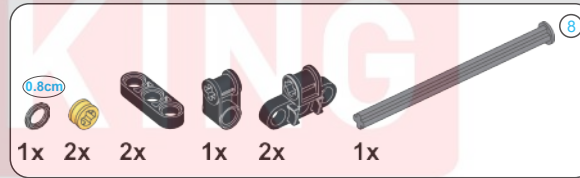
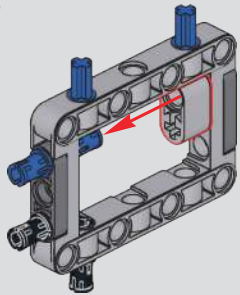

469

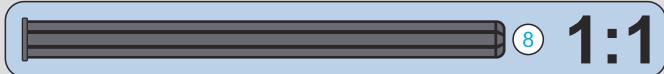
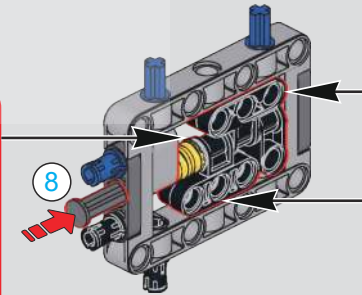
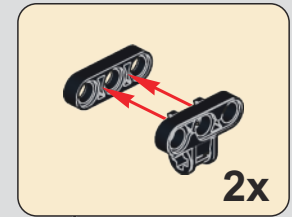
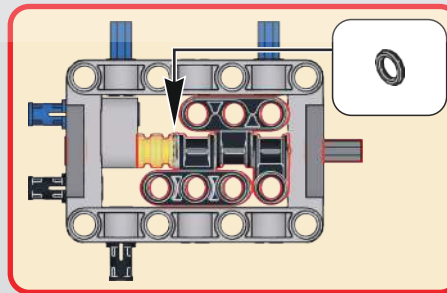

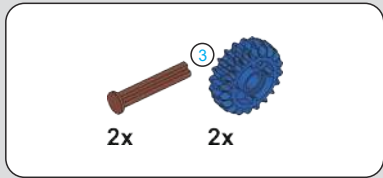

470

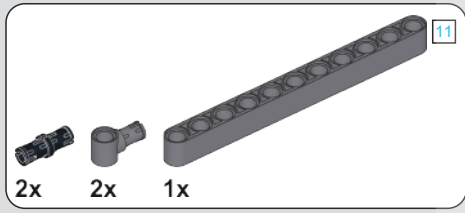
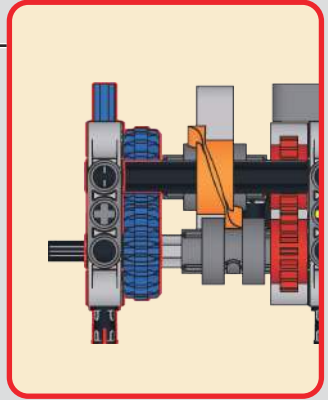
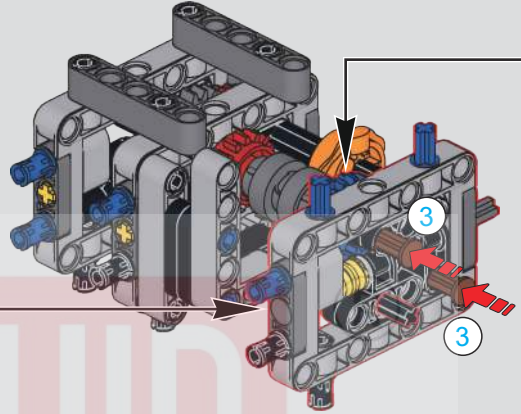
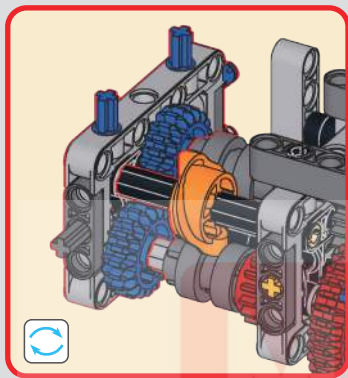

471

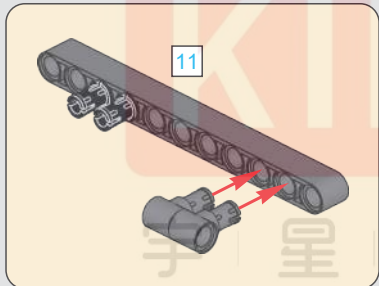

472

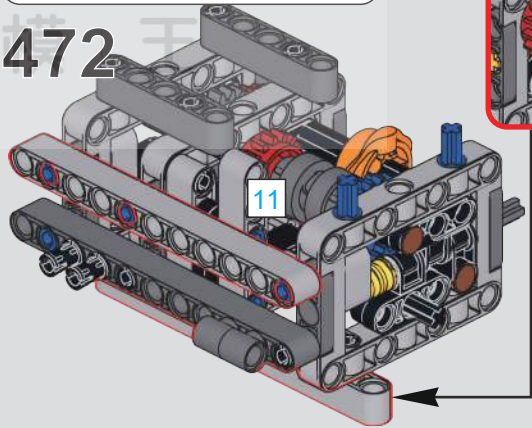
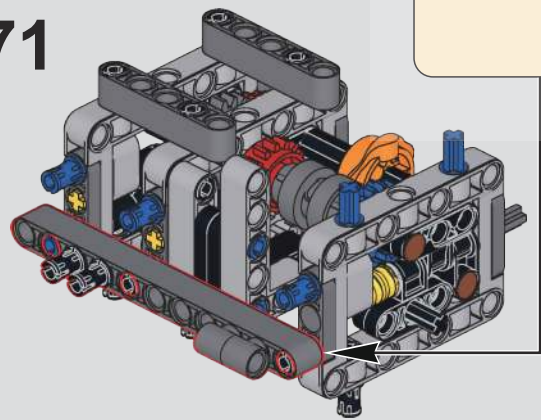
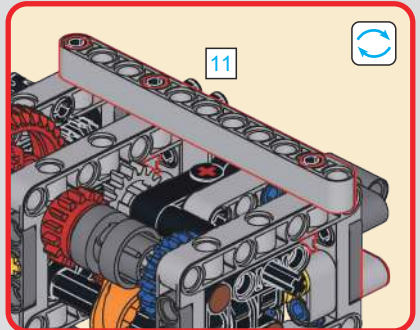

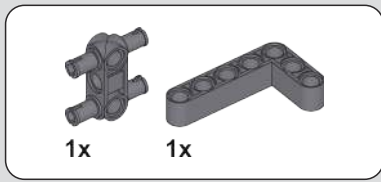

473

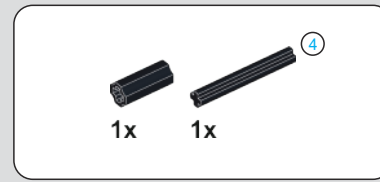
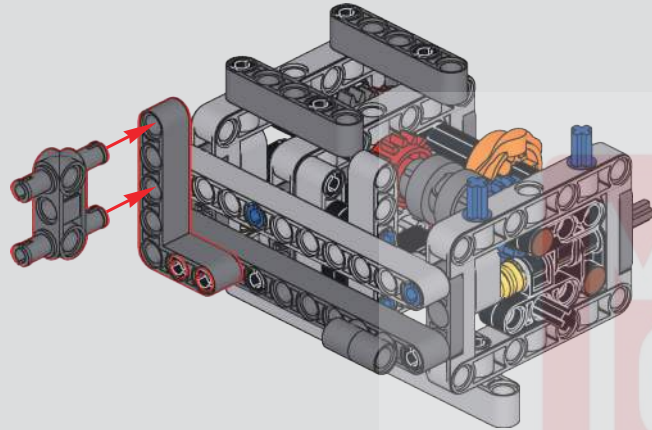

474

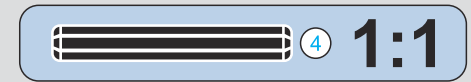
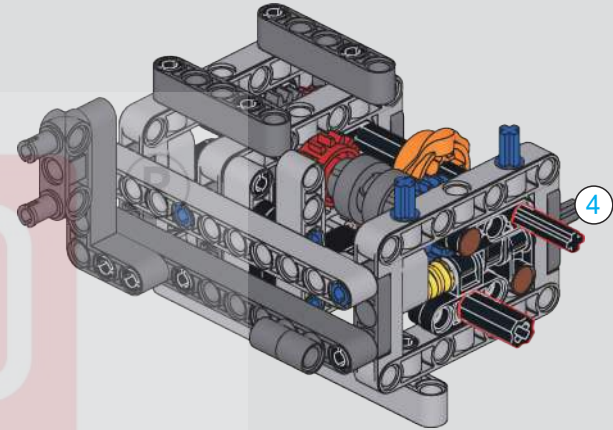

475

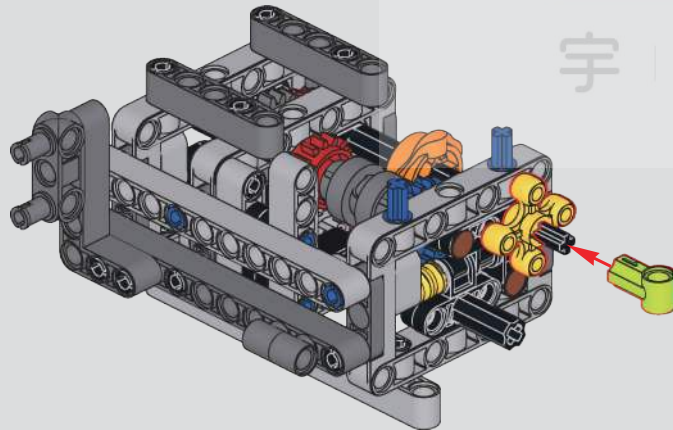

476

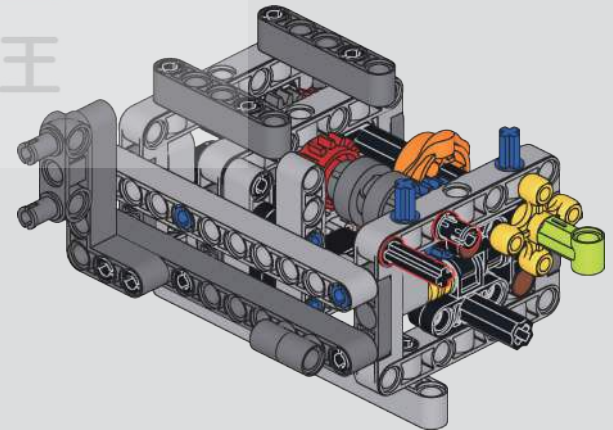

MOULD
KING
宇 | 星 | 模 | 王

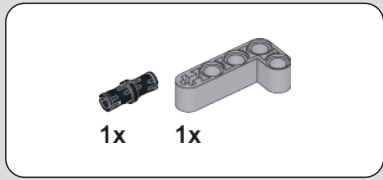

477

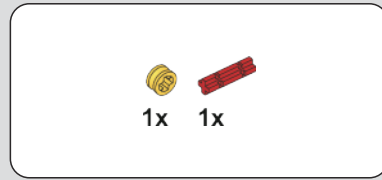
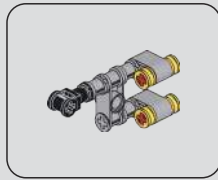
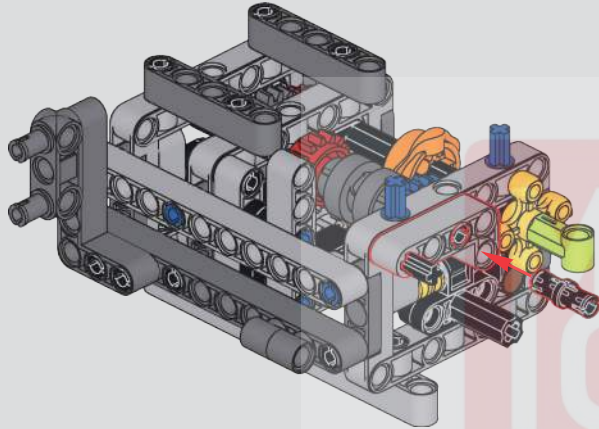

478

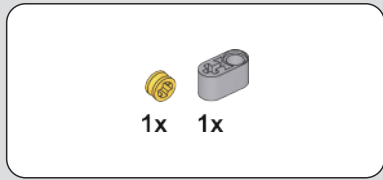
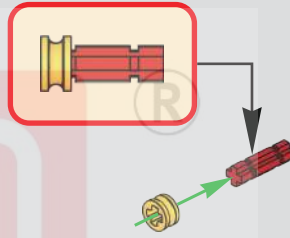

479

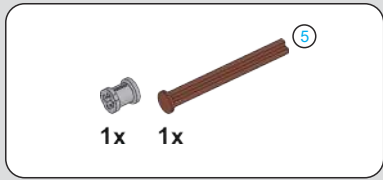
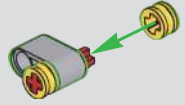

480

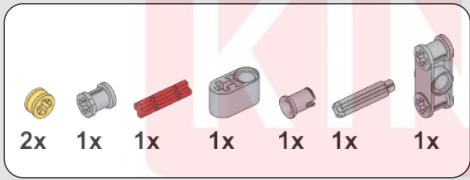
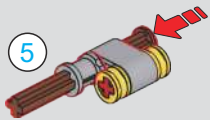

481

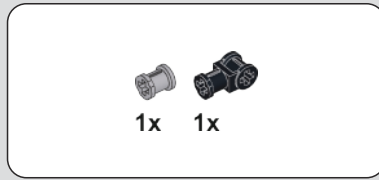
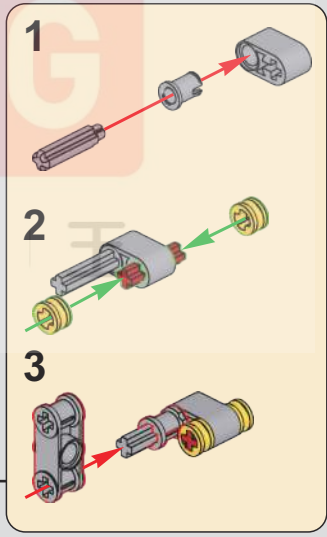
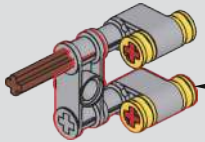

482

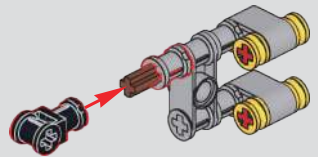

483

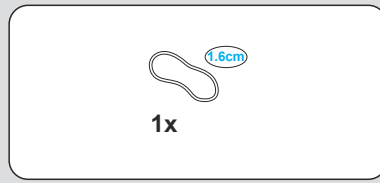

484

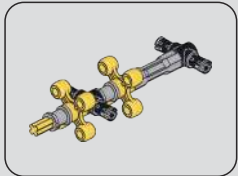
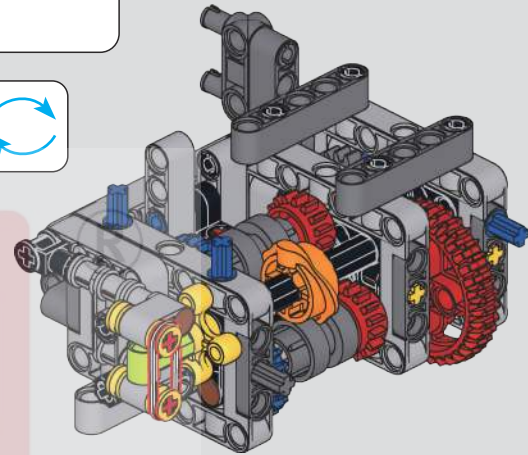
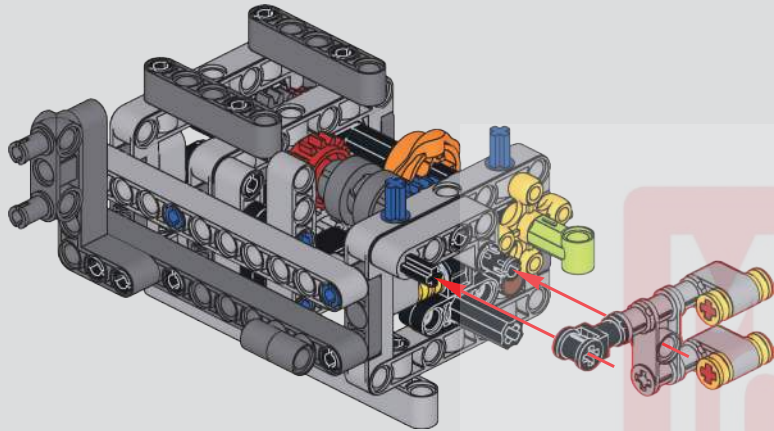

485

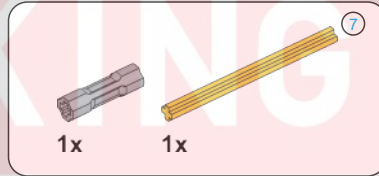

486

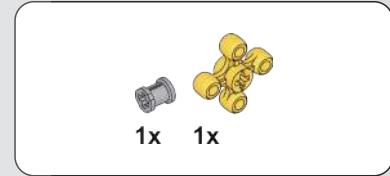

487

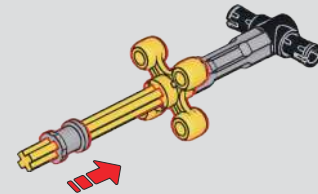
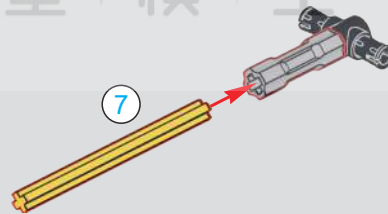
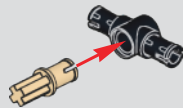

489

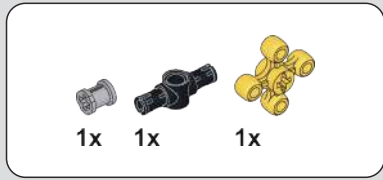

488

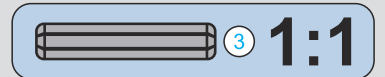
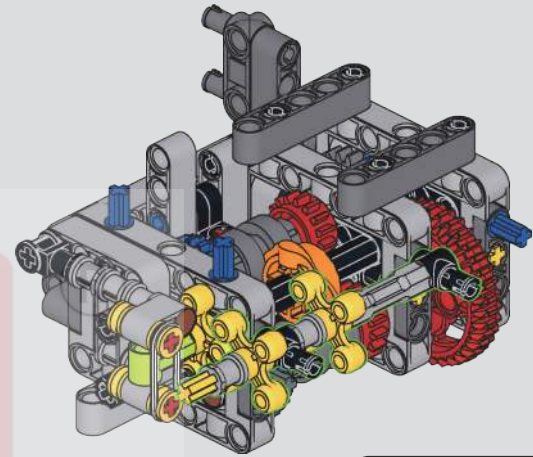
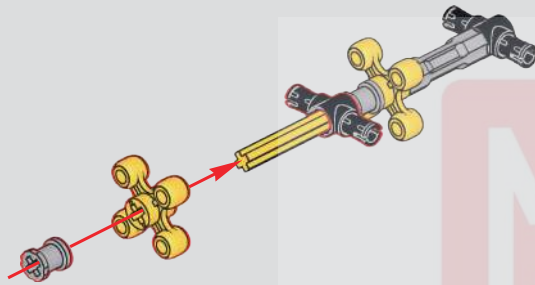

490

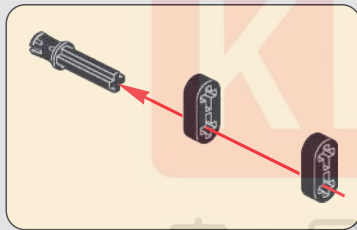
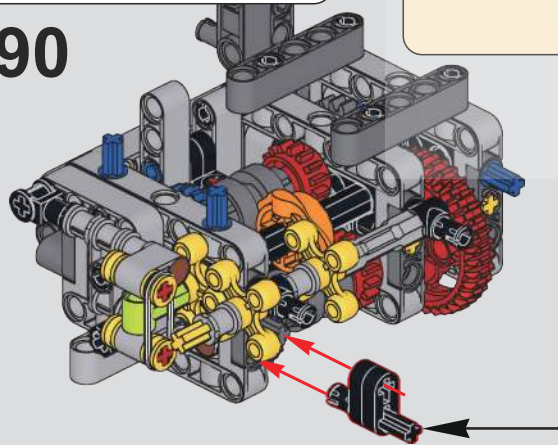

491

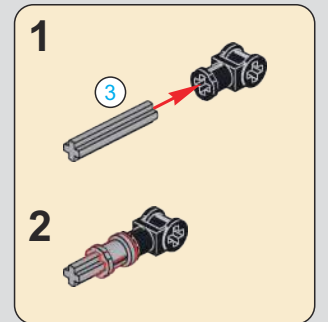
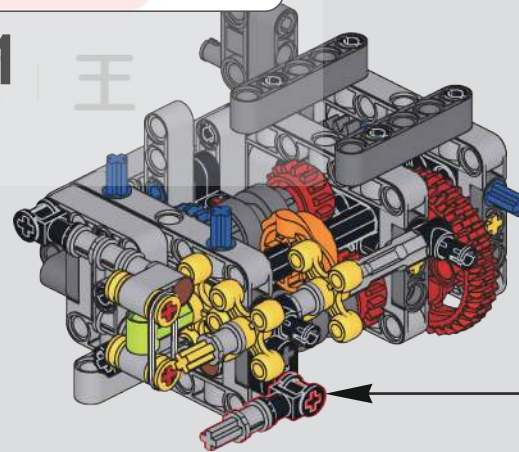

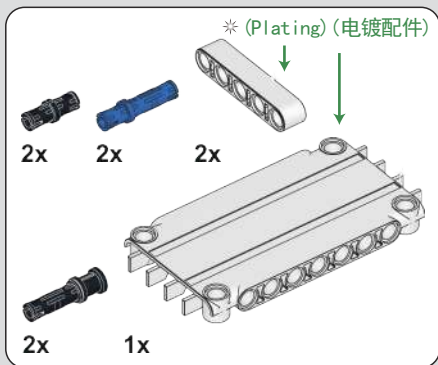

492

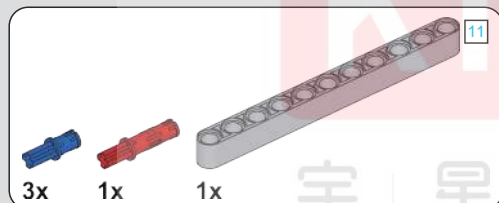
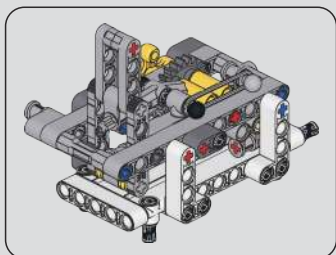
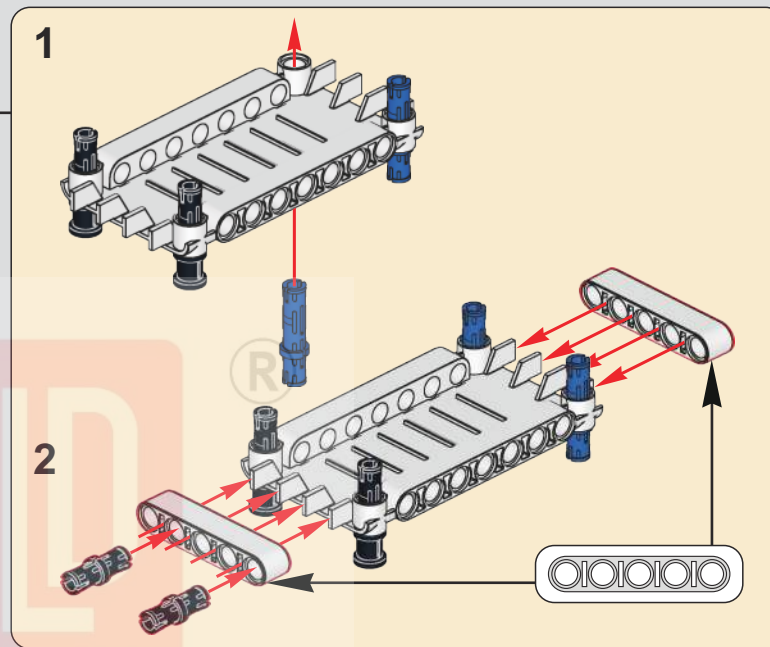
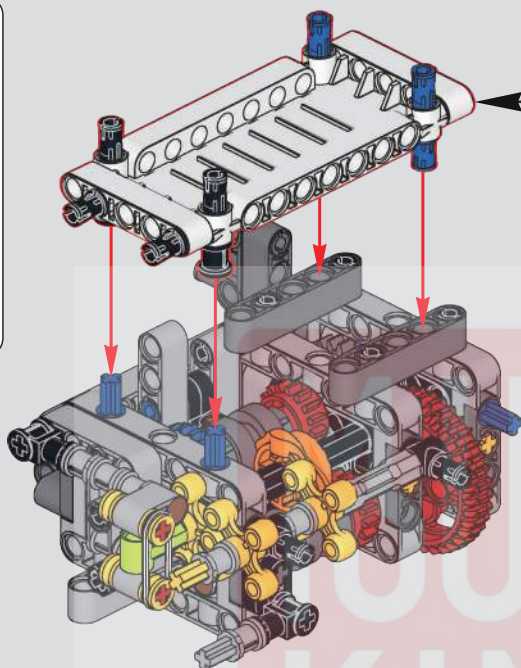

493

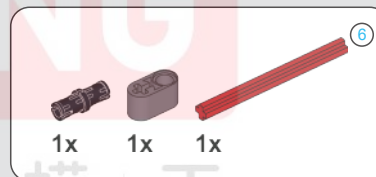
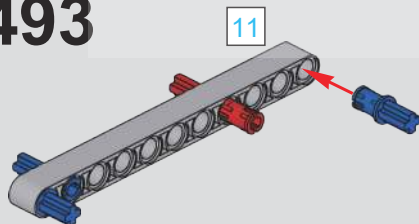

494

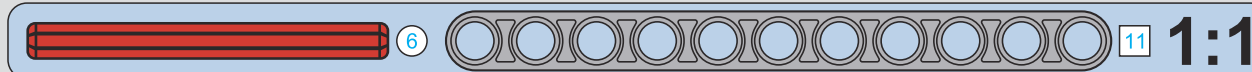
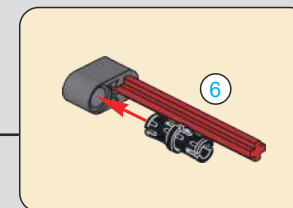
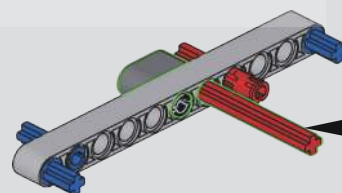

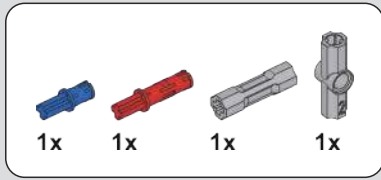

495

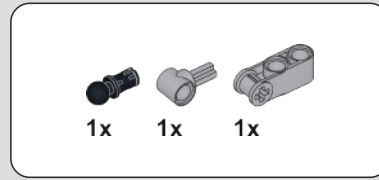
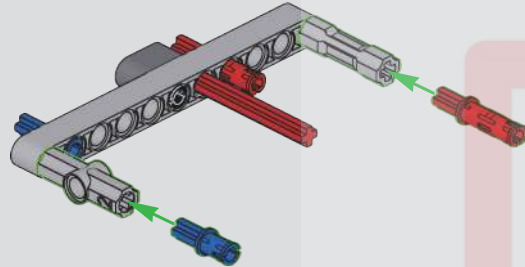

496

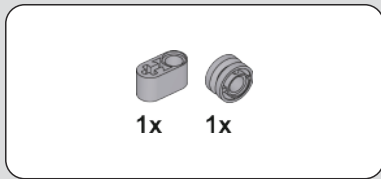
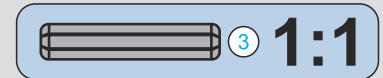
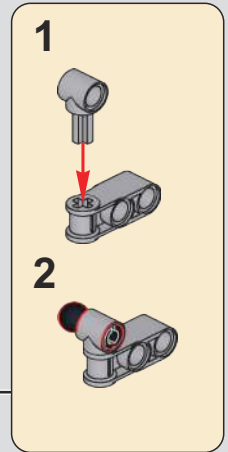
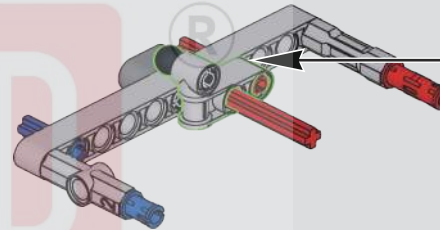

497

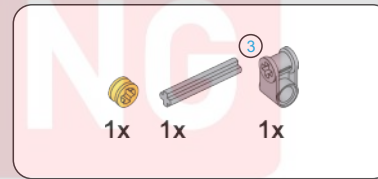
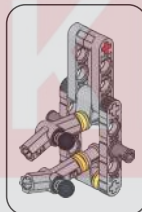
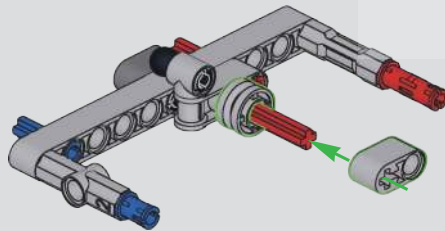

498

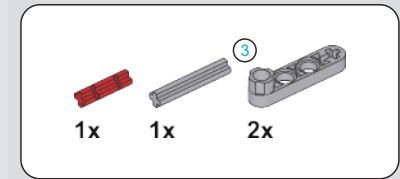
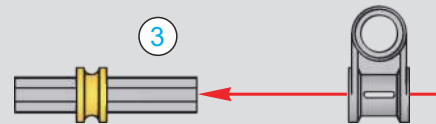

499

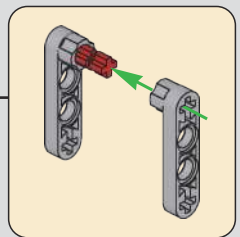
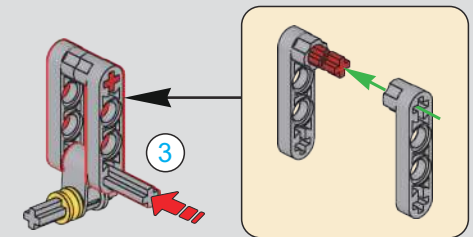

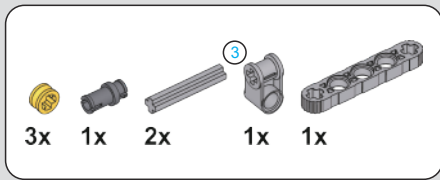

500

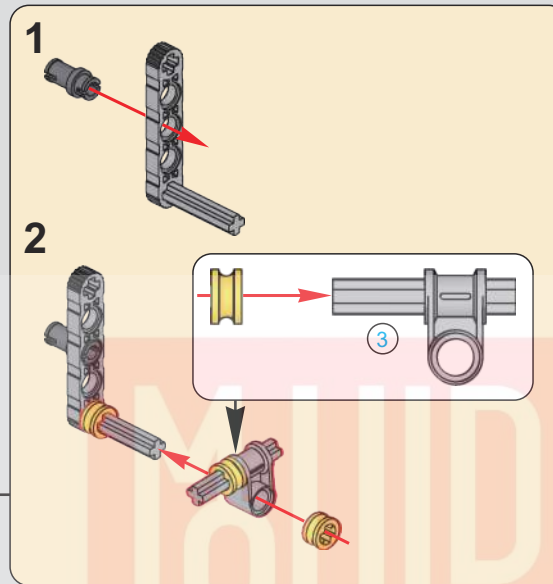
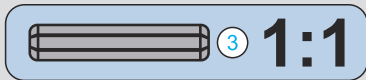
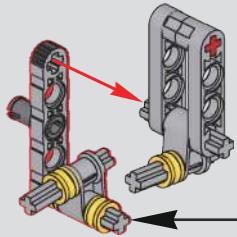

503

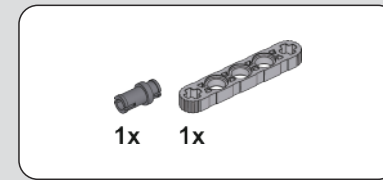
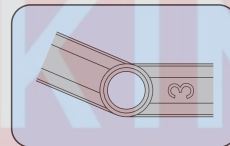

501

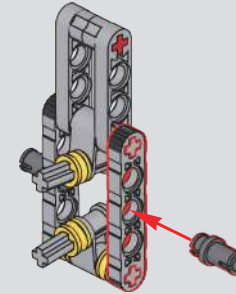

502

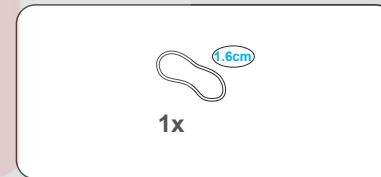
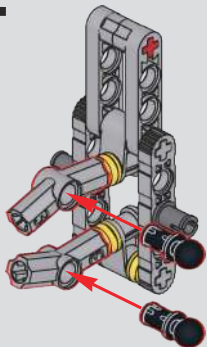

504

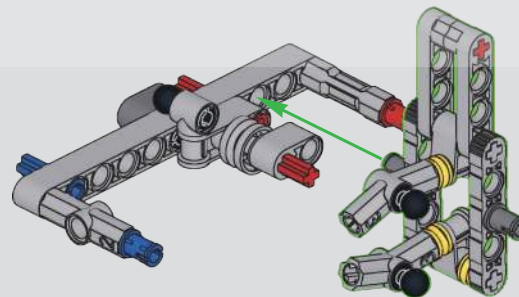
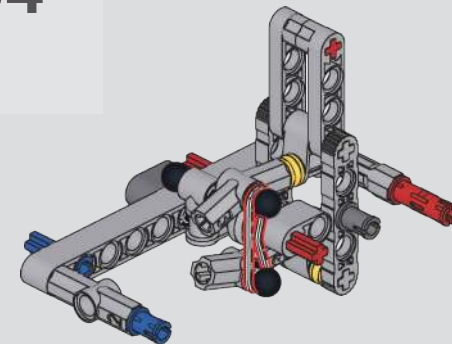

宇 | 星 | 模 | 王

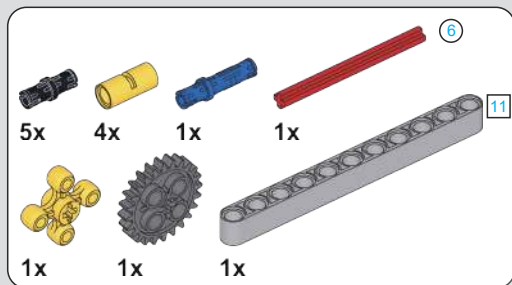

505

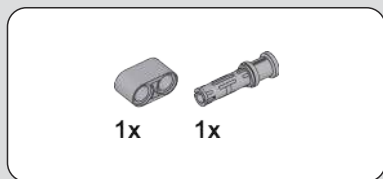
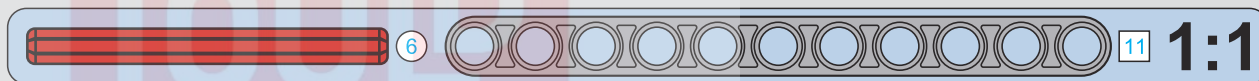
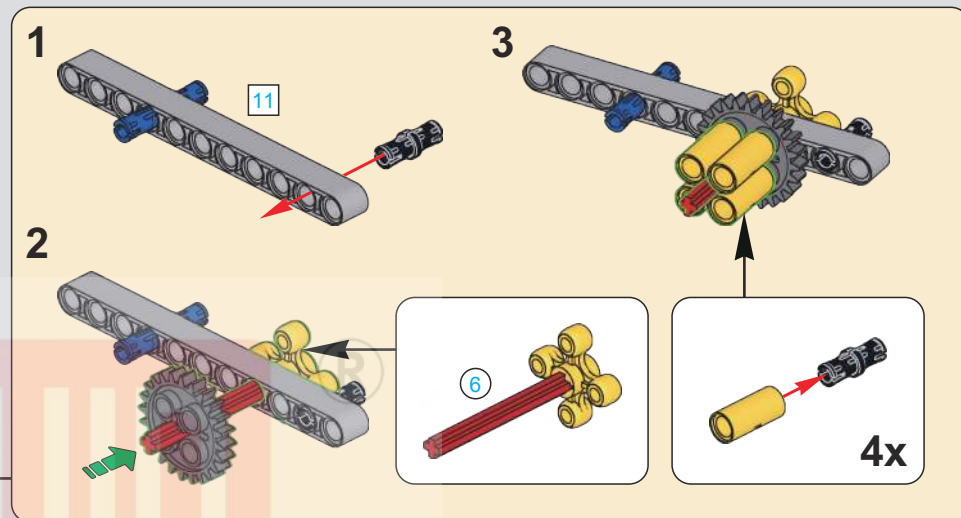
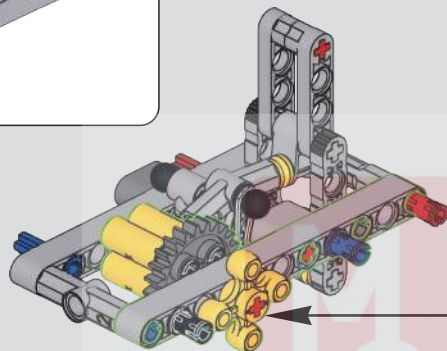

506

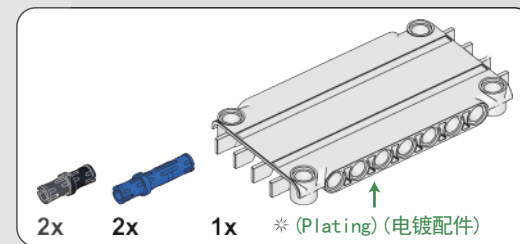
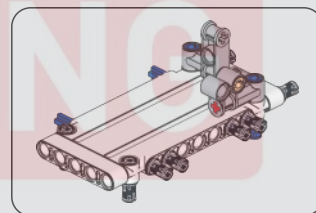
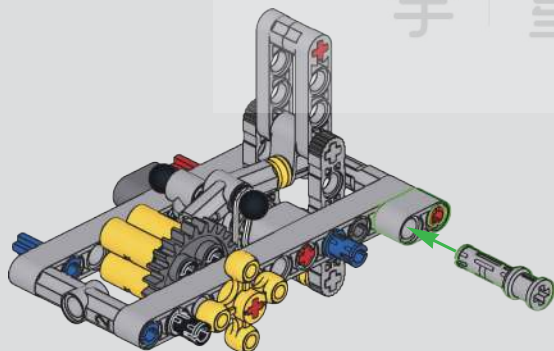

507

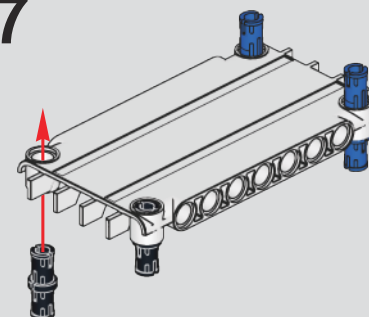

YOU
KING
宇 | 星 | 模 | 王

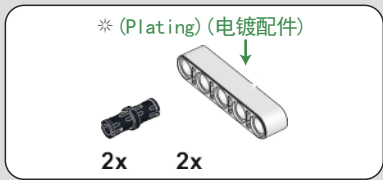

508

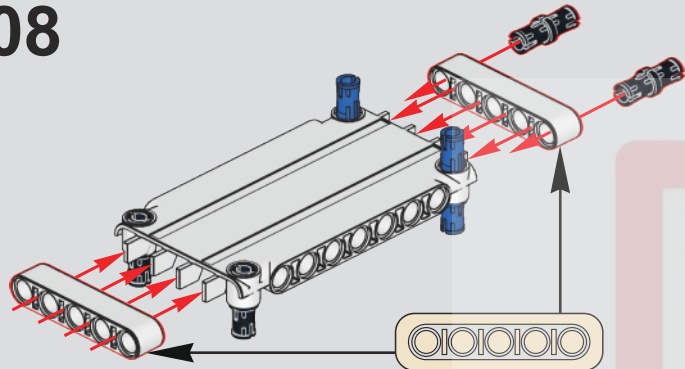

509

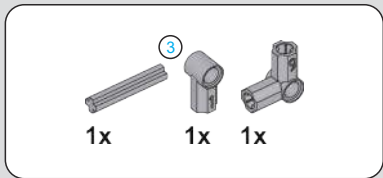
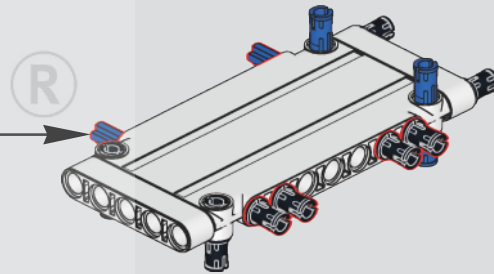
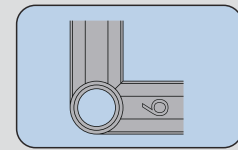
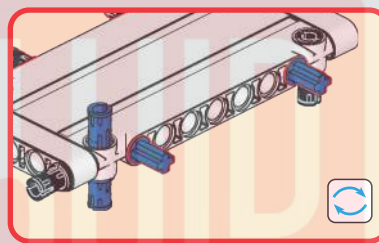

510

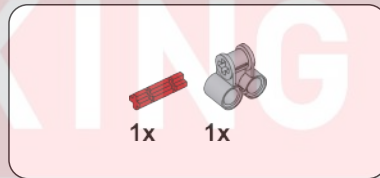
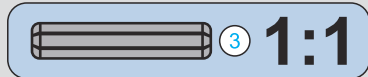
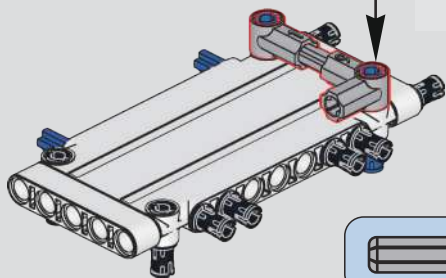
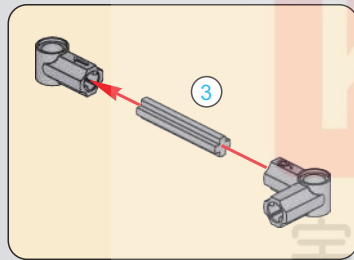

511

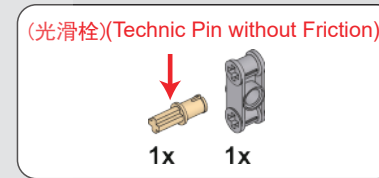
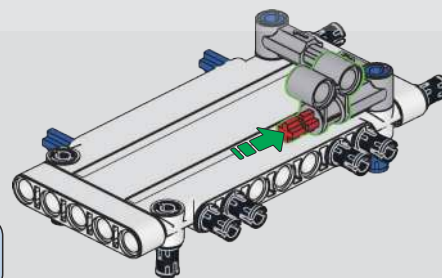

512

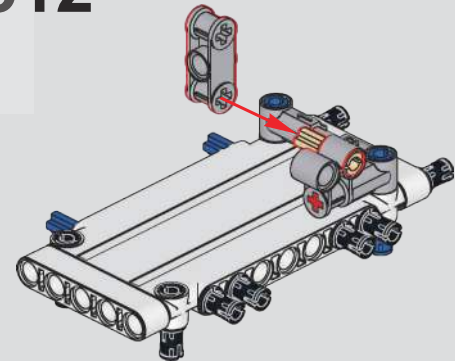

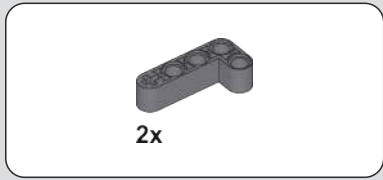

513

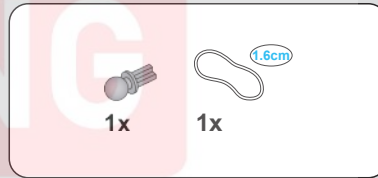
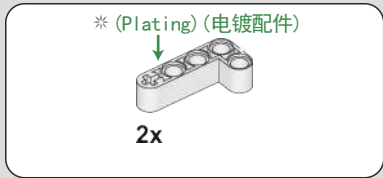
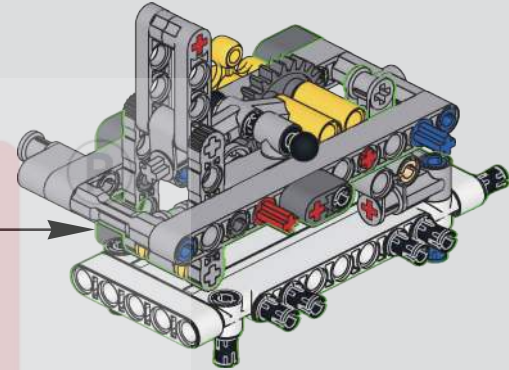
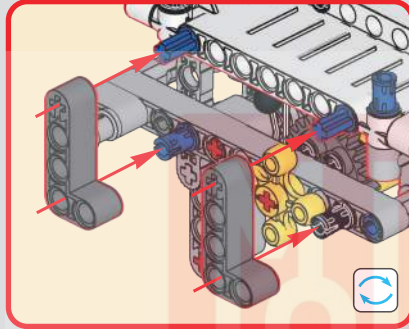

514

515

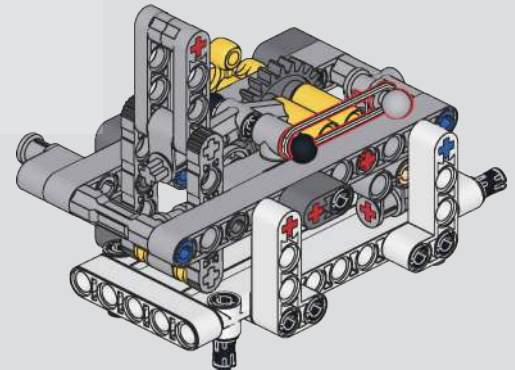
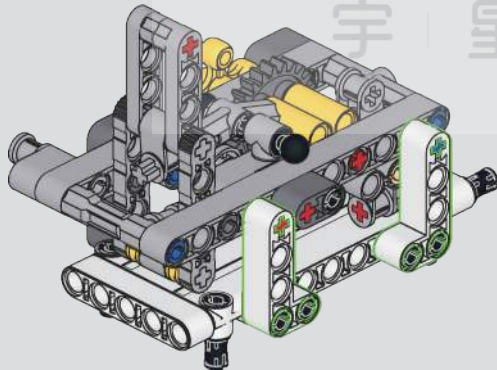

516

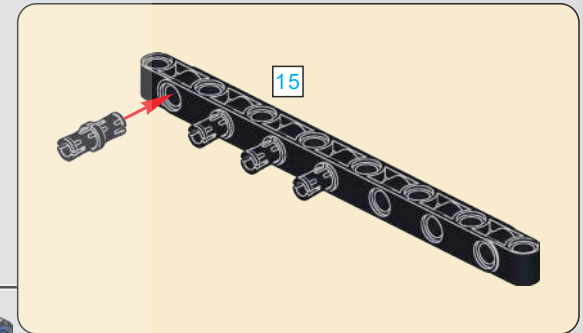
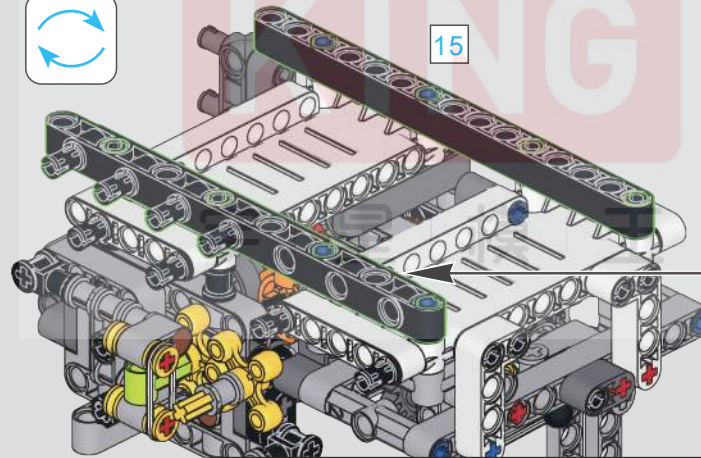
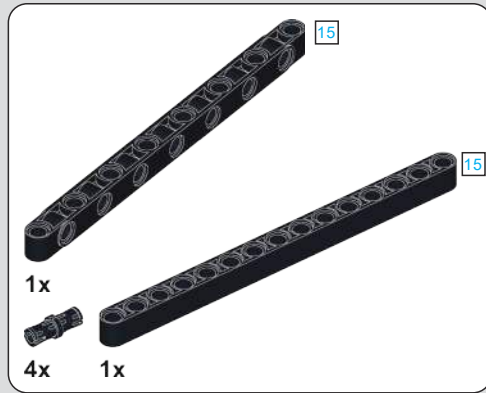
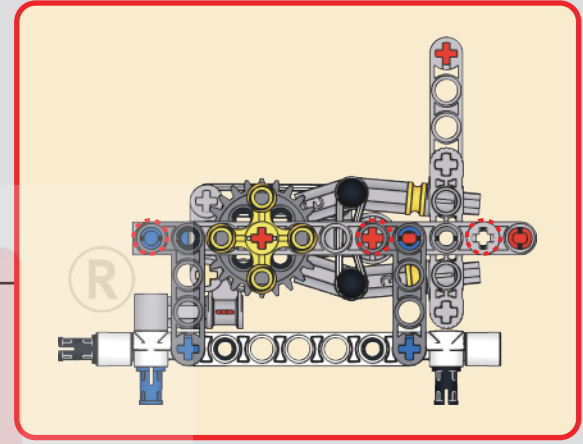
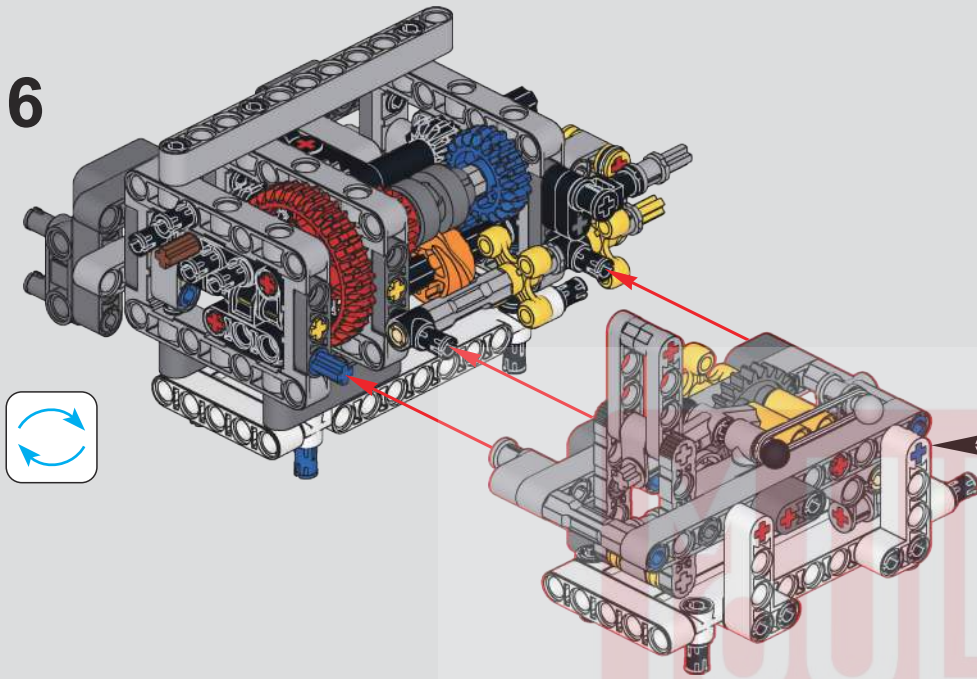

517

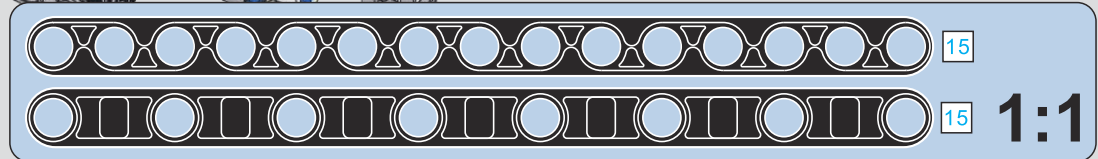

518

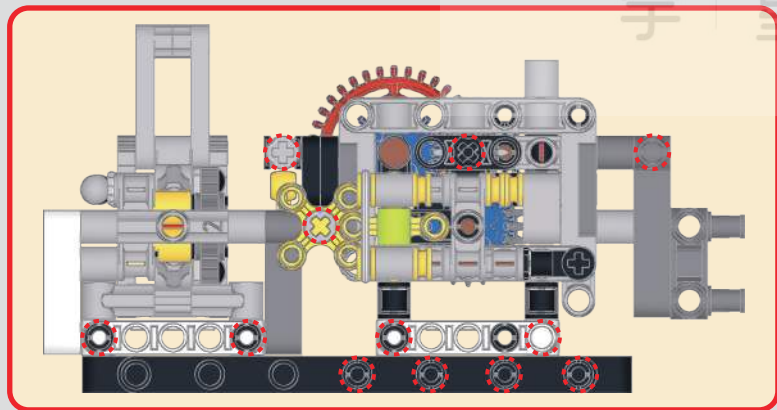
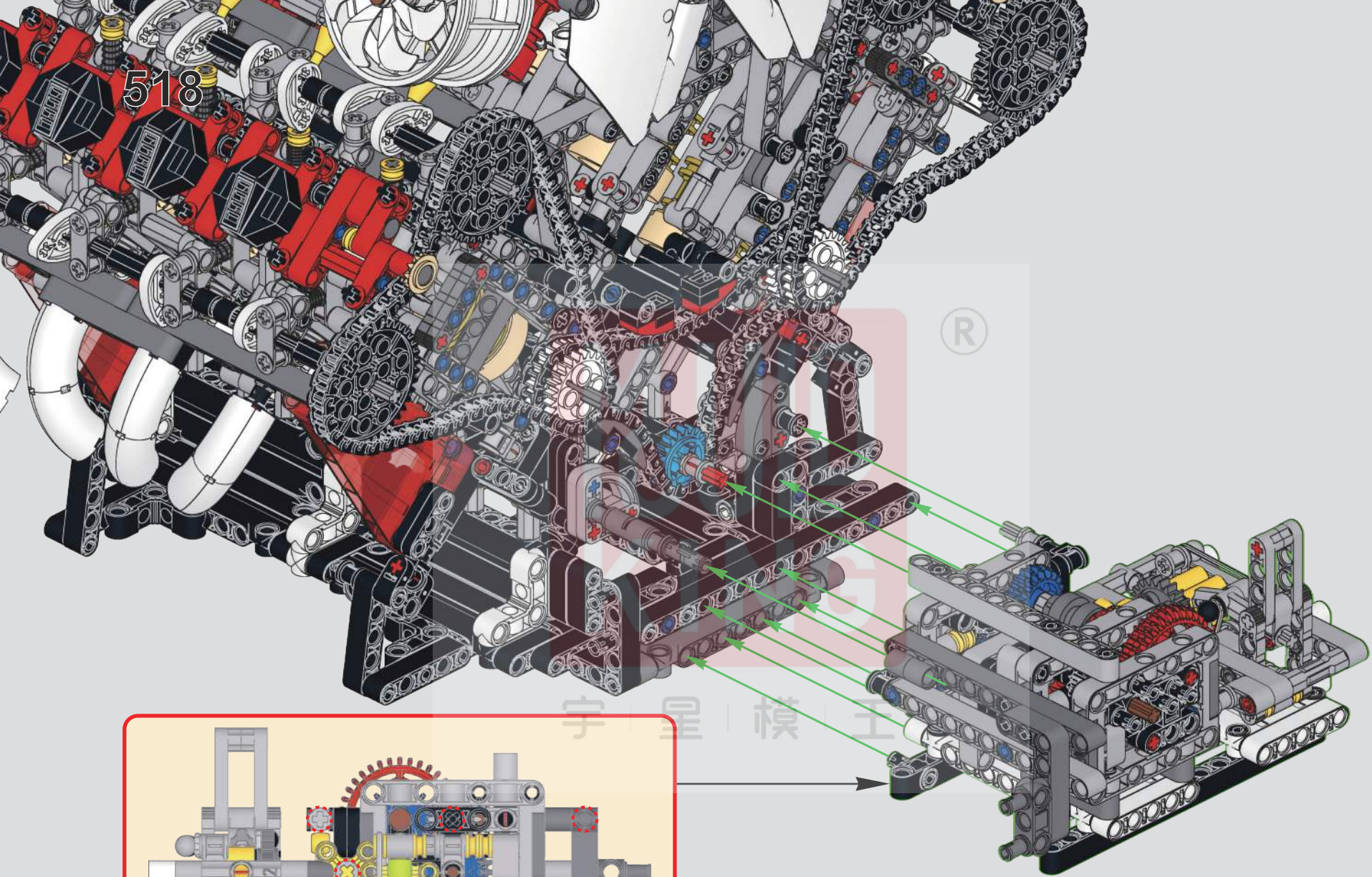

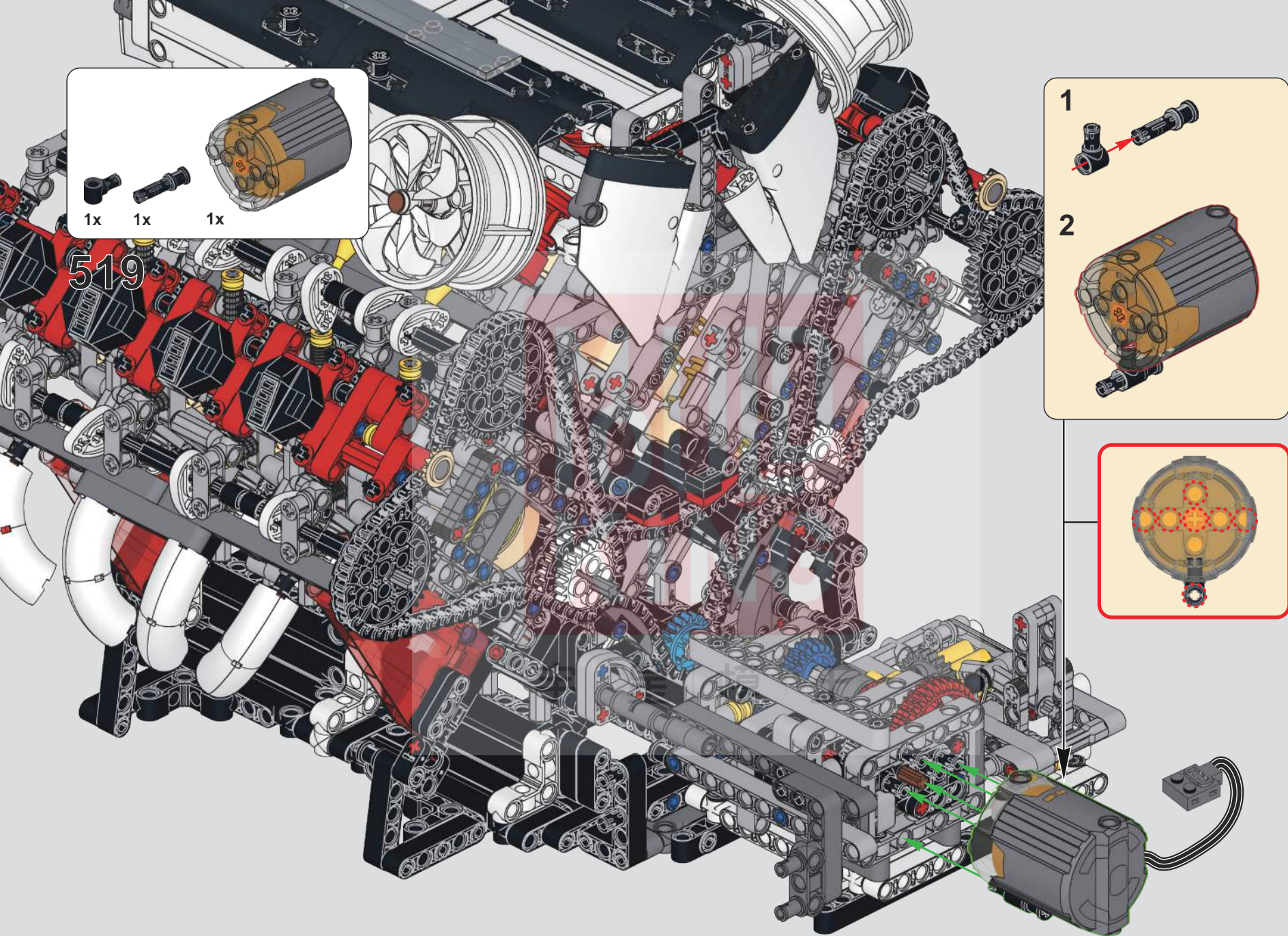

1x 1x 1x

1

2

519

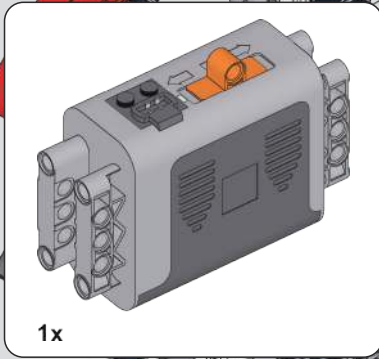

1x

520

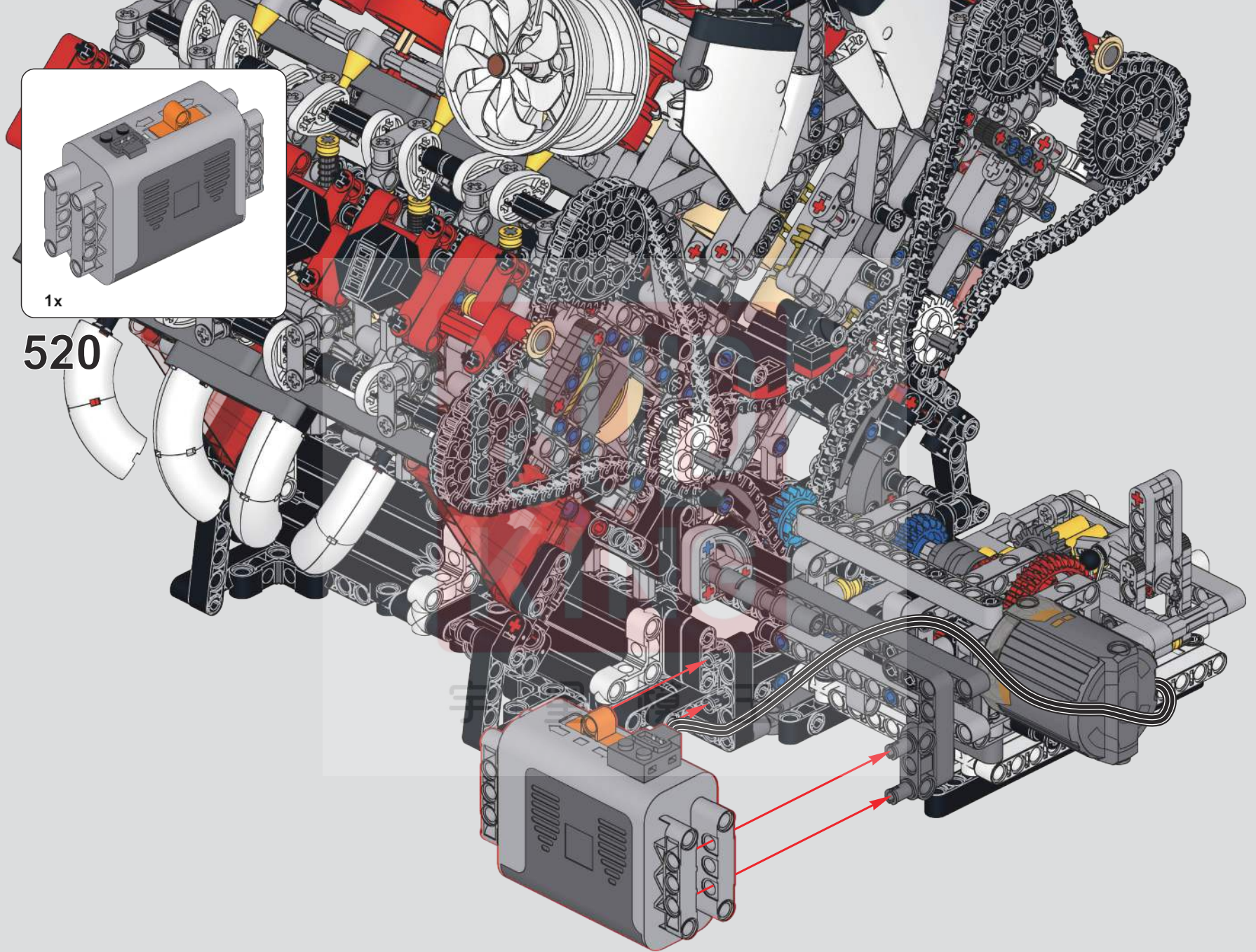

521

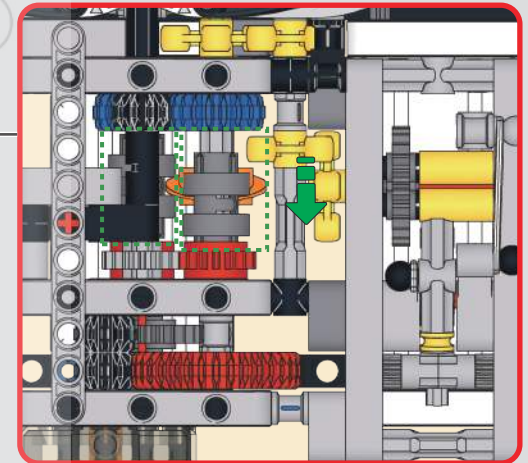
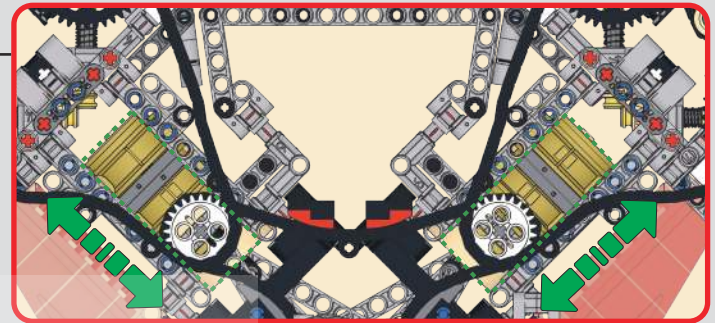
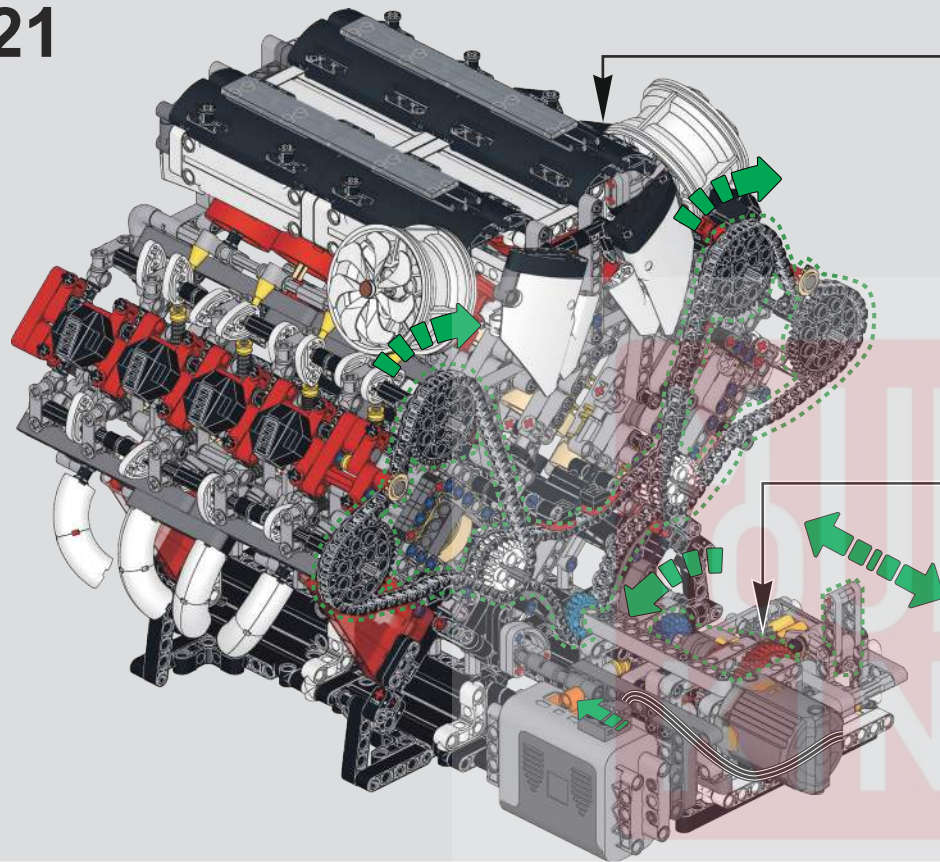

低速挡
 Low Gear
 Niedriger Gang
 Petite vitesse
 Marcia bassa
 低速ギア

低速挡: 推动橙色开关启动发动机, 推动浅灰色挡杆调节档位, 当右侧深灰色动力传输环 (绿圈) 卡入最下方红色齿轮的位置时, 发动机进入低速模式。
 Low Gear: Activate the engine by pushing the orange switch. Adjust the gear by pushing the light grey lever. When the right-side dark grey power transmission ring (green circle) locks into the lowest red gear position, the engine enters low speed mode.
 Niedriger Gang: Starten Sie den Motor, indem Sie den orangefarbenen Schalter drücken. Stellen Sie den Gang ein, indem Sie den hellgrauen Hebel drücken. Wenn der rechtsseitige dunkelgraue Kraftübertragungsring (grüner Kreis) in die niedrigste rote Getriebebeziehung einrastet, tritt der Motor in den langsamen Modus ein.
 Petite vitesse: Activez le moteur en poussant l'interrupteur orange. Réglez la vitesse en poussant le levier gris clair. Lorsque l'anneau de transmission de puissance gris foncé côté droit (cercle vert) se verrouille en position sur l'engrenage rouge le plus bas, le moteur passe en mode basse vitesse.
 Marcia bassa: Attiva il motore spingendo l'interruttore arancione. Regola la marcia spingendo la leva grigio chiaro. Quando l'anello di trasmissione della potenza grigio scuro sul lato destro (cerchio verde) si blocca nella posizione più bassa del ingranaggio rosso, il motore entra in modalità bassa velocità.
 Marcha baja: Activa el motor presionando el interruptor naranja. Ajusta la marcha presionando la palanca gris claro. Cuando el anillo de transmisión de potencia gris oscuro del lado derecho (círculo verde) se encaja en la posición más baja del engranaje rojo, el motor entra en modo de baja velocidad.
 低速ギア: オレンジのスイッチを押してエンジンを起動します。ライトグレーのレバーを押してギアを調整します。右側のダークグレーの動力伝達リング (緑の円) が最も低い赤いギアの位置に固定されると、エンジンは低速モードに入ります。

522

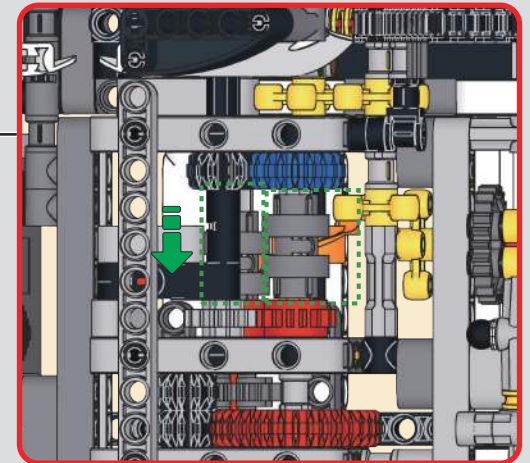
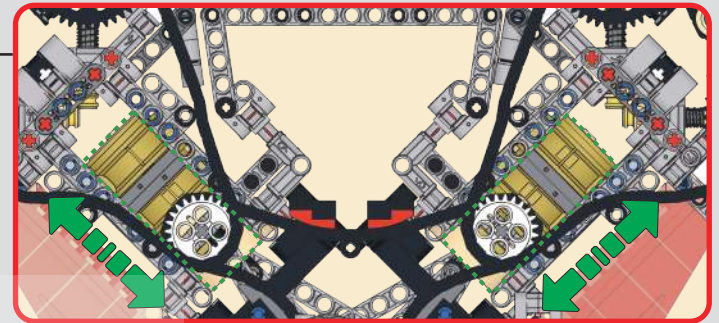
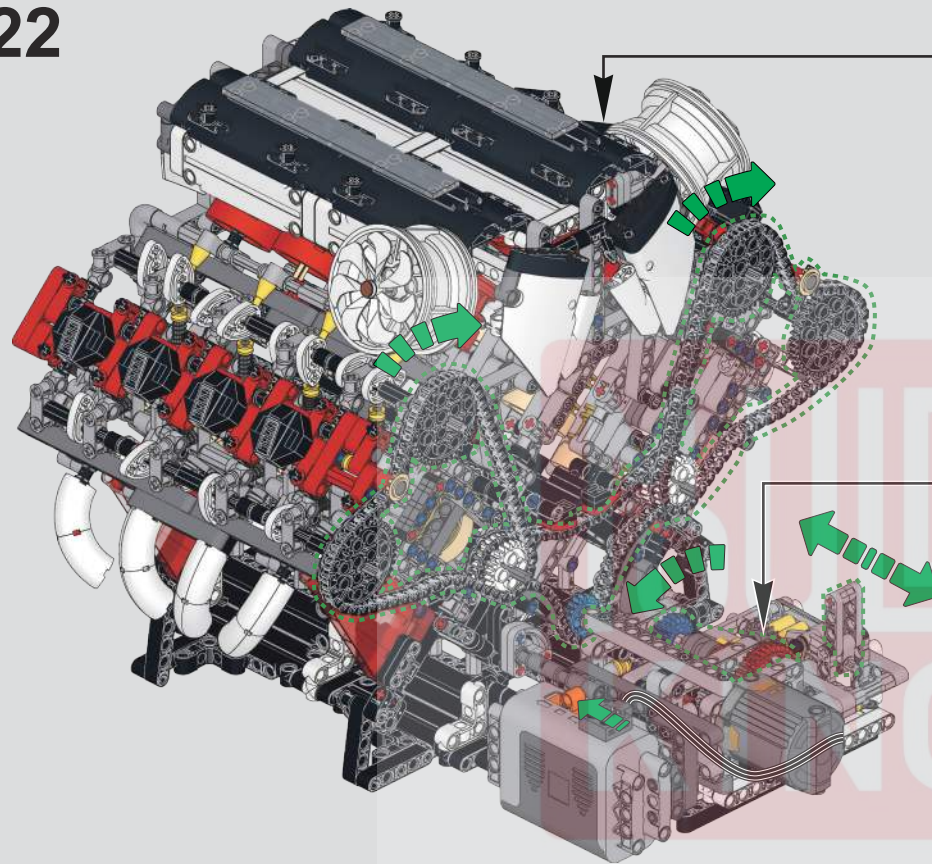

中速挡1
 Medium Gear 1
 Mittlerer Gang 1
 Vitesse moyenne 1
 Marcia media 1
 中速ギア1

中速挡1:继续推动浅灰色挡杆调节档位,当左侧深灰色动力传输环(绿圈)卡入最下方红色齿轮的位置时,发动机进入中速模式1。

Medium Gear 1: Continue pushing the light grey lever to adjust the gear. When the left-side dark grey power transmission ring (green circle) locks into the lowest red gear position, the engine enters medium speed mode 1.

Mittlerer Gang 1: Drücken Sie weiterhin den hellgrauen Hebel, um den Gang einzustellen. Wenn der linksseitige dunkelgraue Kraftübertragungsring (grüner Kreis) in die niedrigste rote Getriebeposition einrastet, tritt der Motor in den mittleren Geschwindigkeitsmodus 1 ein.

Vitesse moyenne 1: Continuez à pousser le levier gris clair pour ajuster la vitesse. Lorsque l'anneau de transmission de puissance gris foncé côté gauche (cercle vert) se verrouille en position sur l'engrenage rouge le plus bas, le moteur passe en mode vitesse moyenne 1.

Marcia media 1: Continua a spingere la leva grigio chiaro per regolare la marcia. Quando l'anello di trasmissione della potenza grigio scuro sul lato sinistro (cerchio verde) si blocca nella posizione più bassa del ingranaggio rosso, il motore entra in modalità di media velocità 1.

Marcha media 1: Continúa presionando la palanca gris claro para ajustar la marcha. Cuando el anillo de transmisión de potencia gris oscuro del lado izquierdo (círculo verde) se encaja en la posición más baja del engranaje rojo, el motor entra en modo de velocidad media 1.

中速ギア1:ライトグレーのレバーを押し続けてギアを調整します。左側のダークグレーの動力伝達リング(緑の円)が最も低い赤いギアの位置に固定されると、エンジンは中速モード1に入ります。

523

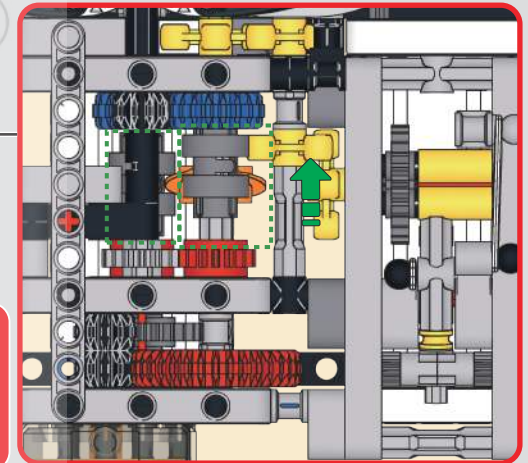
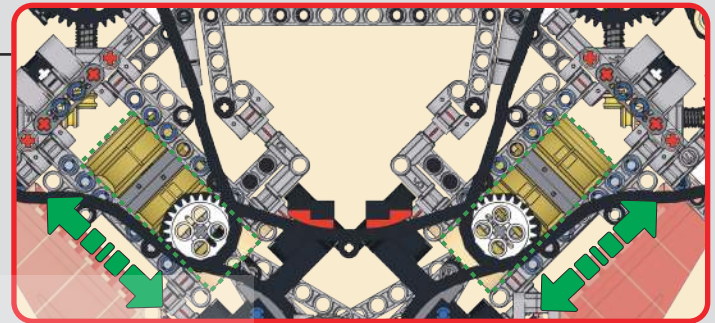
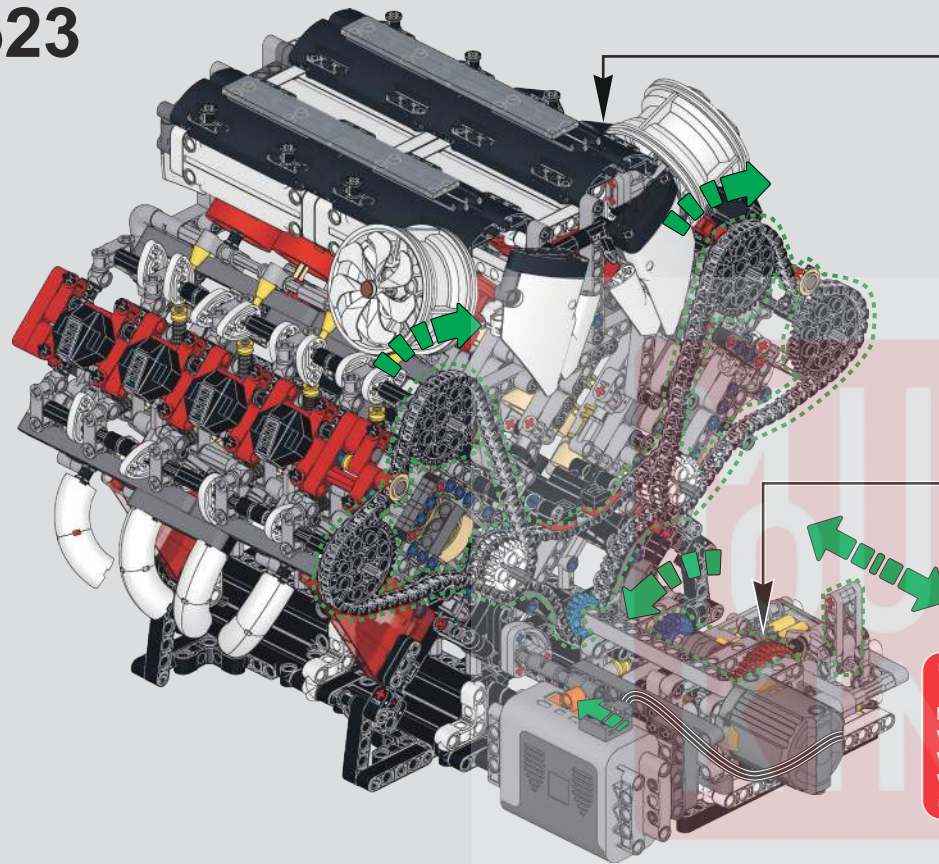

中速挡2
 Intermediate Speed 2
 Mittlere Geschwindigkeitsstufe 2
 Vitesse intermédiaire 2
 Velocità intermedia 2
 Velocidad Intermedia 2
 中速モード2

中速挡2: 继续推动浅灰色挡杆调节档位, 当右侧深灰色动力传输环卡入最上方蓝色齿轮的位置时, 发动机进入中速模式2.**

Intermediate Speed 2: Continue to push the light grey gear lever to adjust the gear. When the right dark grey power transmission ring locks into the position of the top blue gear, the engine enters Intermediate Speed Mode 2.

Mittlere Geschwindigkeitsstufe 2: Schieben Sie den hellgrauen Ganghebel weiter, um den Gang einzustellen. Wenn der rechte dunkelgraue Kraftübertragungsring in die Position des obersten blauen Zahnrads einrastet, tritt der Motor in die mittlere Geschwindigkeitsstufe 2 ein.

Vitesse intermédiaire 2 : Continuez à pousser le levier de vitesse gris clair pour régler la vitesse. Lorsque l'anneau de transmission de puissance gris foncé à droite s'enclenche dans la position de l'engrenage bleu supérieur, le moteur passe en mode vitesse intermédiaire 2.

Velocità intermedia 2: Continua a spingere la leva del cambio grigio chiaro per regolare la marcia. Quando l'anello di trasmissione di potenza grigio scuro a destra si blocca nella posizione dell'ingranaggio blu superiore, il motore entra nella Modalità Velocità Intermedia 2.

Velocidad Intermedia 2: Continúa empujando la palanca de cambios gris claro para ajustar la marcha. Cuando el anillo de transmisión de potencia gris oscuro del lado derecho se encaja en la posición del engranaje azul superior, el motor entra en el Modo de Velocidad Intermedia 2.

中速モード2: ライトグレーのギアレバーを押し続けてギアを調整します。右側のダークグレーのパワートランスミッションリングが上部のブルーギアの位置にロックされると、エンジンは中速モード2に入ります。

524

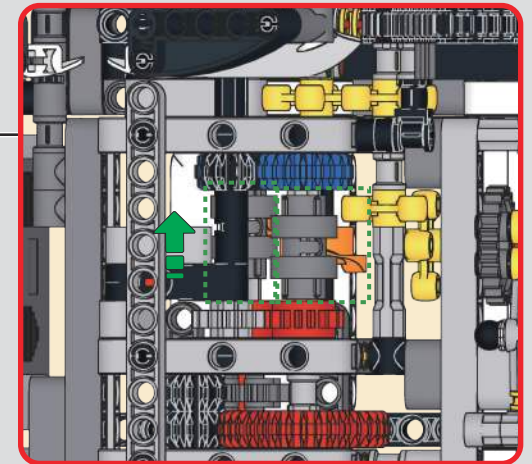
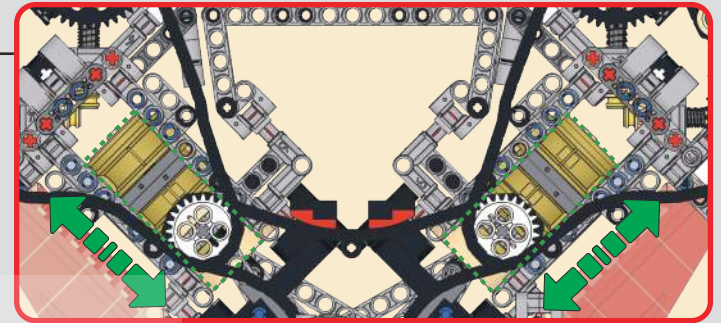
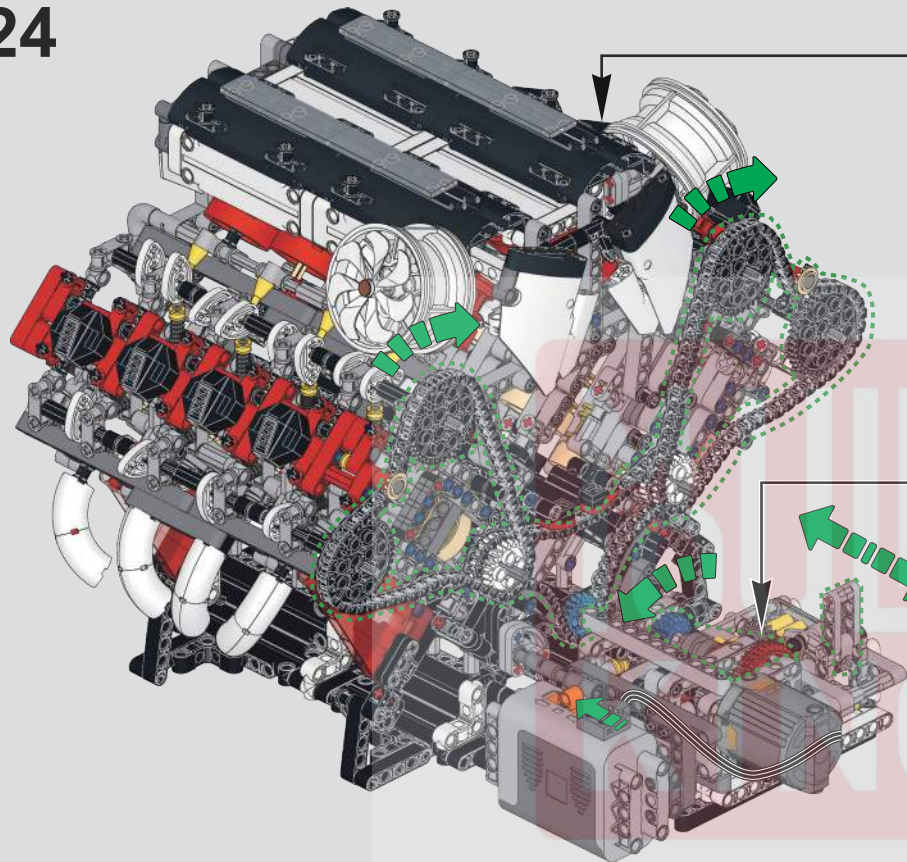

高速挡
 High Gear
 Hoher Gang
 Grande vitesse
 Marcia alta
 Marcha alta
 高速ギア

高速档: 继续推动浅灰色挡杆调节档位, 当左侧深灰色动力传输环卡入最上方蓝色齿轮的位置时, 发动机进入高速模式。

High Gear: Continue pushing the light grey lever to adjust the gear. When the left-side dark grey power transmission ring locks into the topmost blue gear position, the engine enters high speed mode.

Hoher Gang: Drücken Sie weiterhin den hellgrauen Hebel, um den Gang einzustellen. Wenn der linksseitige dunkelgraue Kraftübertragungsring in die oberste blaue Getriebebeziehung einrastet, tritt der Motor in den hohen Geschwindigkeitsmodus ein.

Grande vitesse: Continuez à pousser le levier gris clair pour ajuster la vitesse. Lorsque l'anneau de transmission de puissance gris foncé côté gauche se verrouille en position sur l'engrenage bleu le plus haut, le moteur passe en mode haute vitesse.

Marcia alta: Continua a spingere la leva grigio chiaro per regolare la marcia. Quando l'anello di trasmissione della potenza grigio scuro sul lato sinistro si blocca nella posizione più alta del ingranaggio blu, il motore entra in modalità alta velocità.

Marcha alta: Continúa presionando la palanca gris claro para ajustar la marcha. Cuando el anillo de transmisión de potencia gris oscuro del lado izquierdo se encaja en la posición más alta del engranaje azul, el motor entra en modo de alta velocidad.

高速ギア: ライトグレーのレバーを押し続けてギアを調整します。左側のダークグレーの動力伝達リングが最も高い青いギアの位置に固定されると、エンジンは高速モードに入ります。

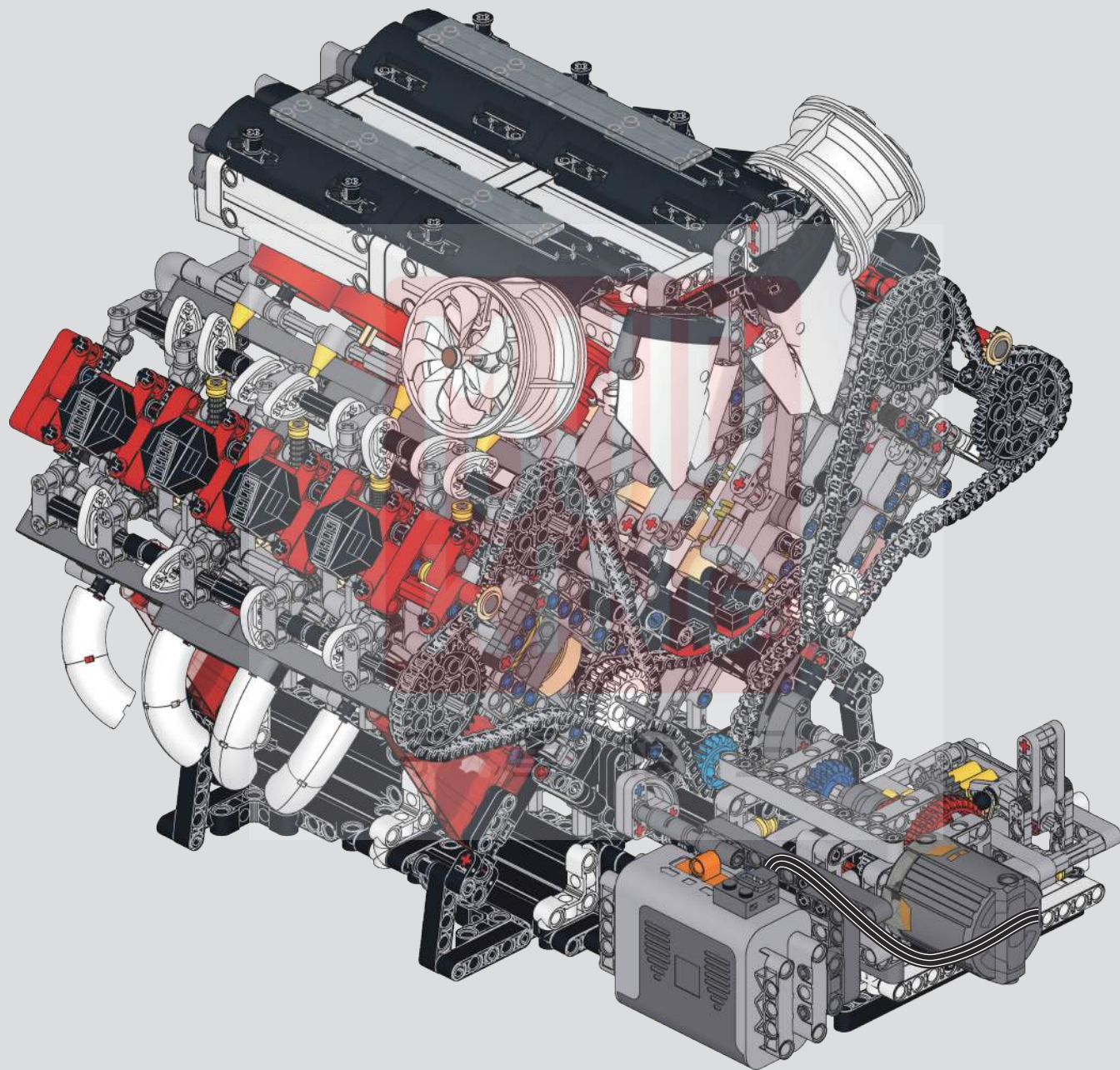

526

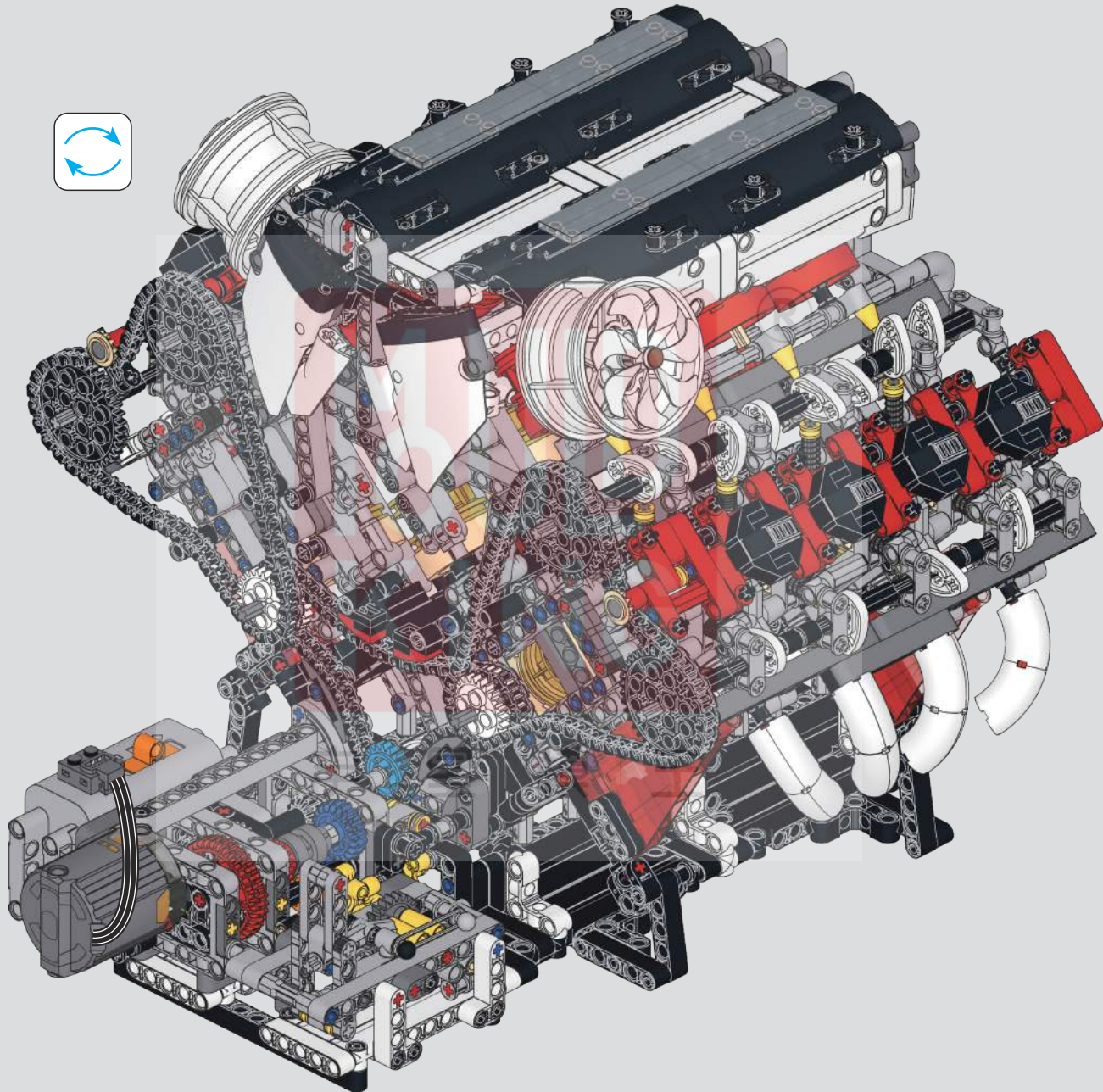



宇 | 星 | 模 | 王

