

**MOLD
KING**

®

宇 | 星 | 模 | 王

17026

1803 + Pcs/Pza

宇星工程系列
MODELS

NQ 气动装载机L550
Pneumatic Loader L550





Qr code APP (APP二维码)

Need the apple version 9.0 and above, the android version 5.0 and above.

* This APP supports most of the mainstream Android models on the market, but due to the large number of Android models, different models of systems and hardware reasons, there may be some models do not support, specific according to the actual test!



广东宇星科技
Mould King



产品资讯

Product Information

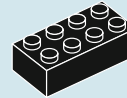

积木补件

Brick Replacement Service



售后服务

After-sales Service

Customer Service
客户服务



www.yx-mk.com

OPEN

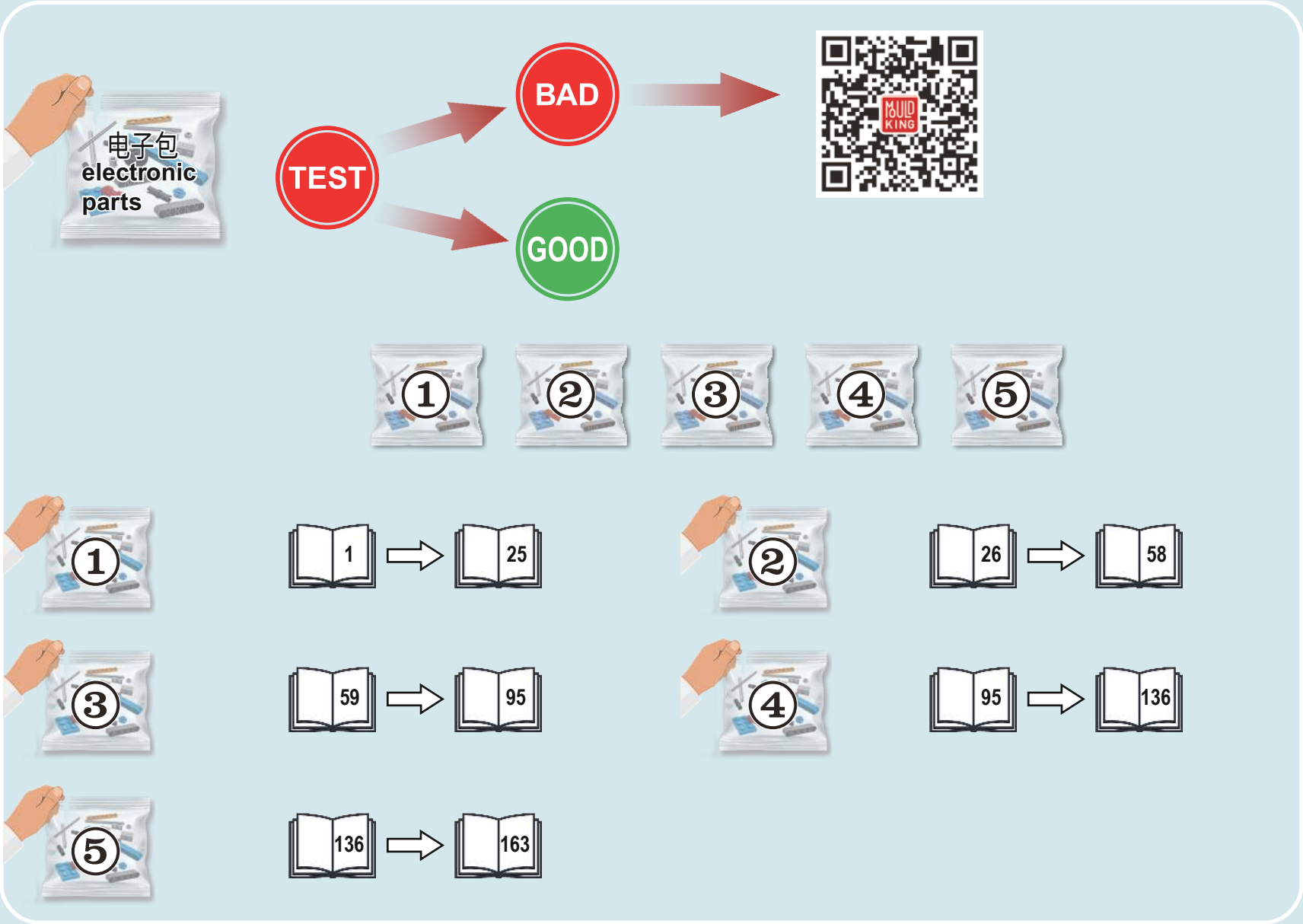

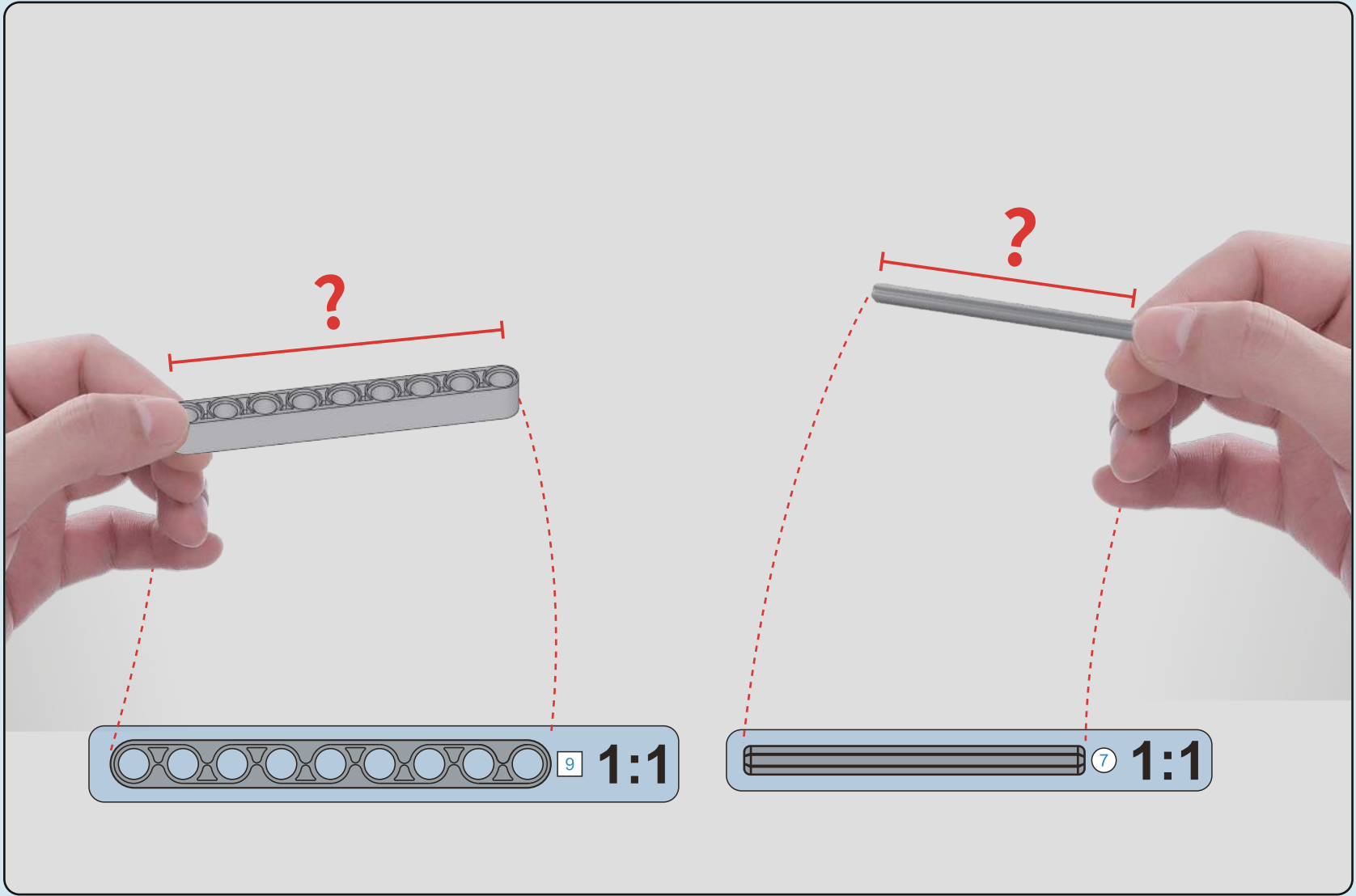

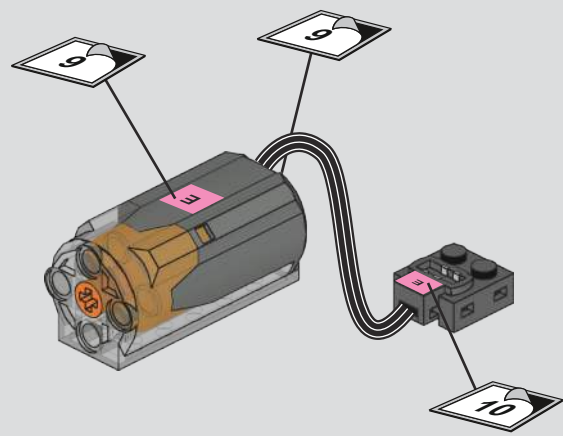
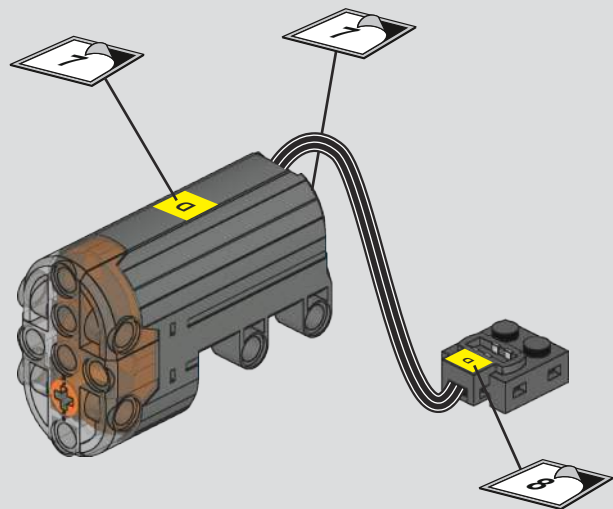
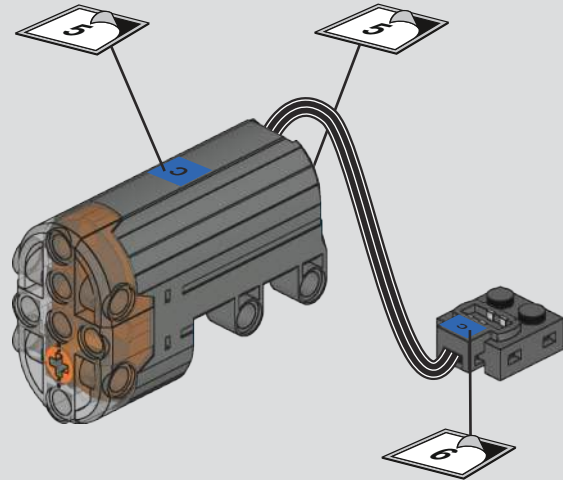
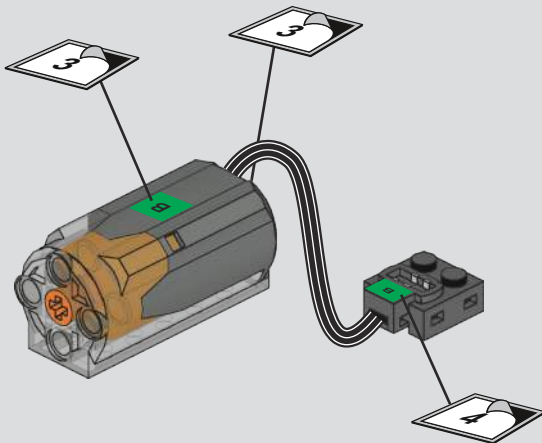
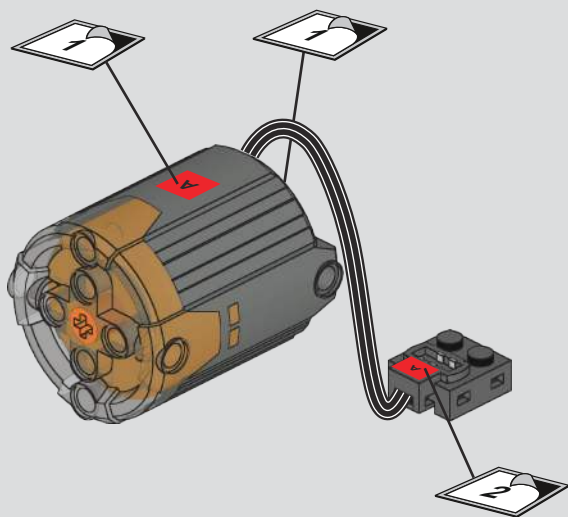

拼装前需测试所有电子件功能是否正常

Test all electronic components for functionality before assembly.

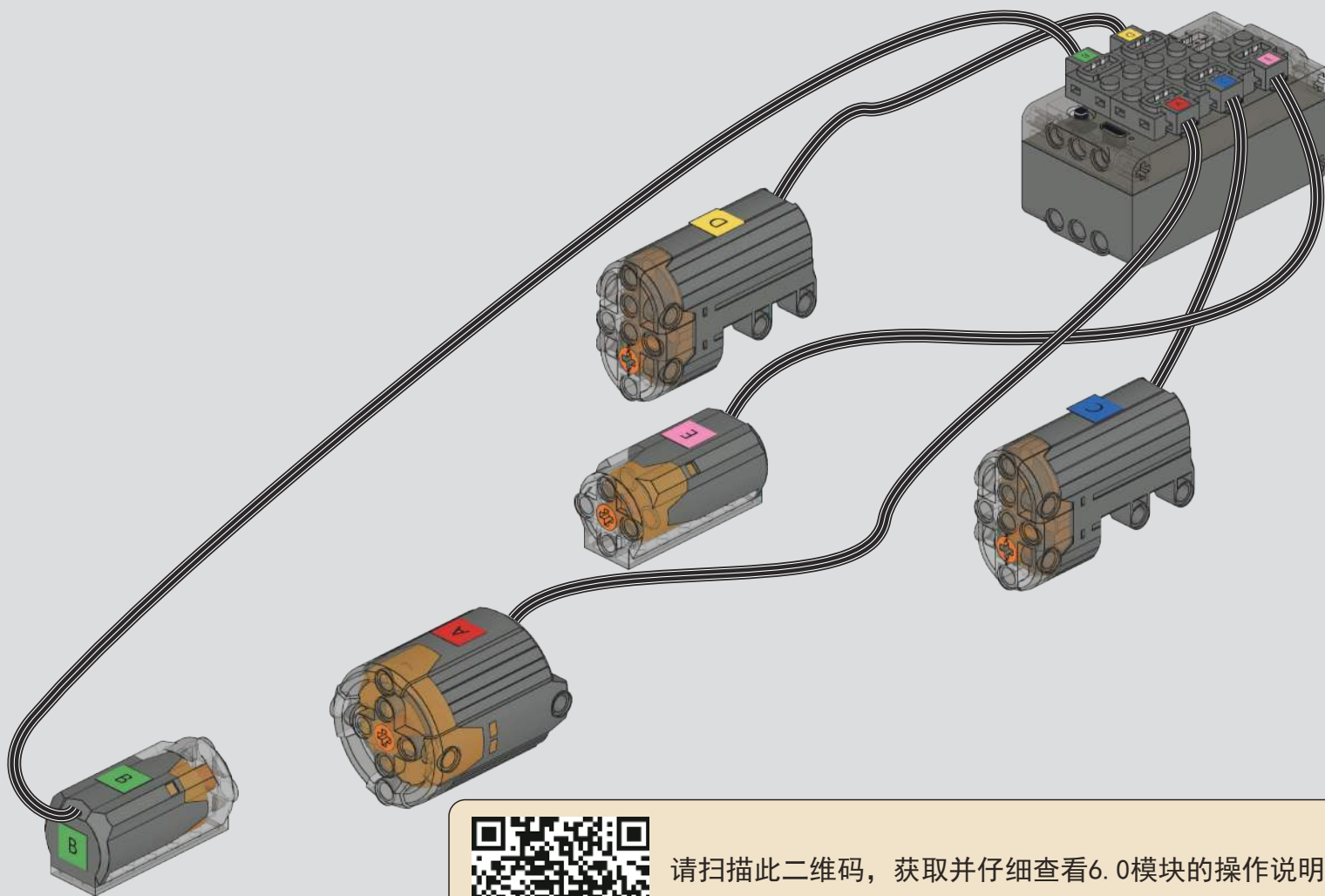

请扫描此二维码，获取并仔细查看6.0模块的操作说明书。

Please scan this QR code to obtain and carefully review the operation manual for the 6.0 module.

0

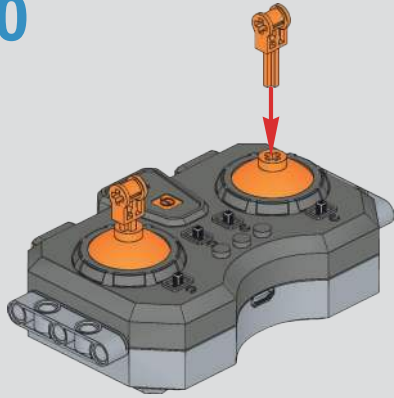

1

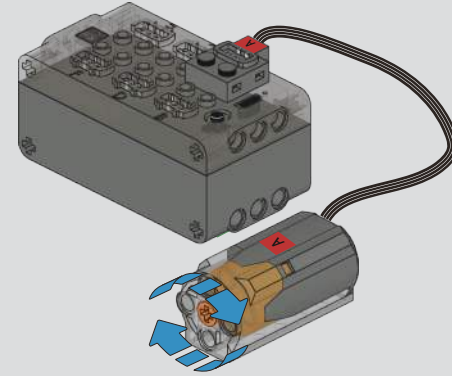
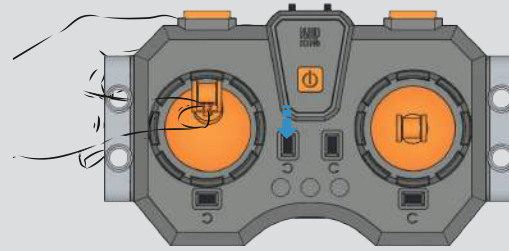

2

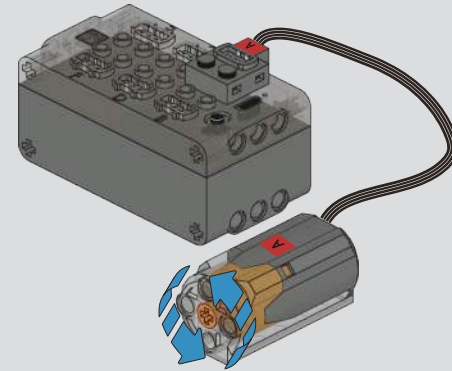
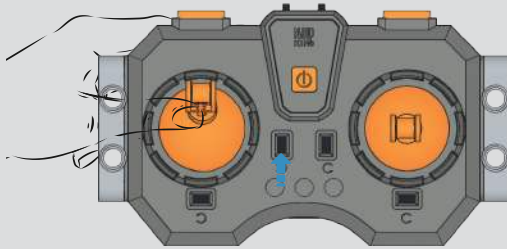

3

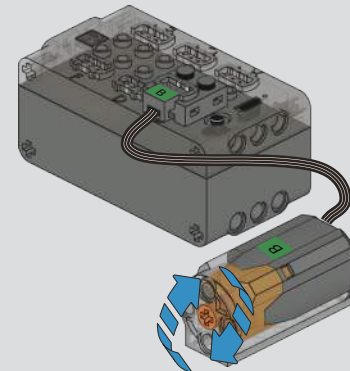
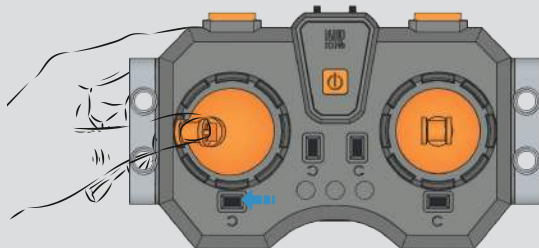

4

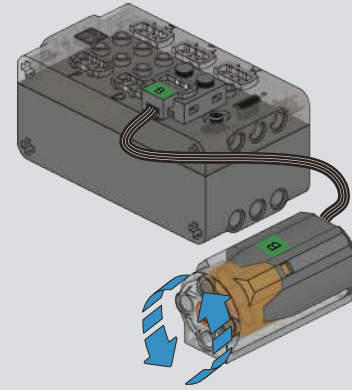
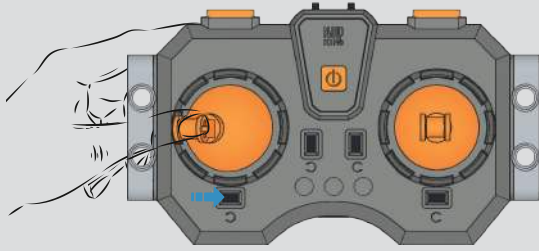

5

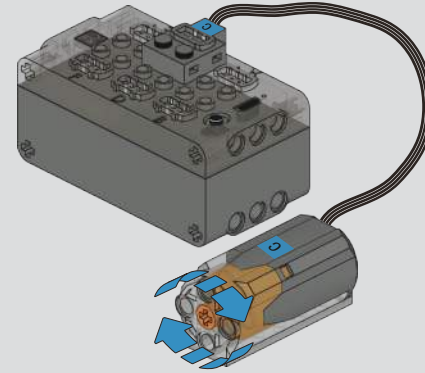
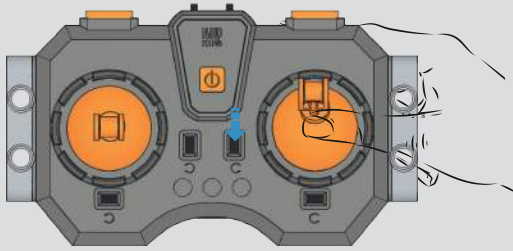

6

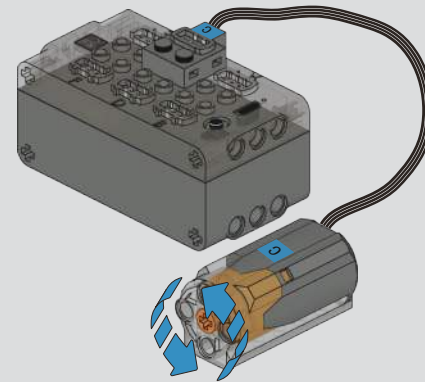
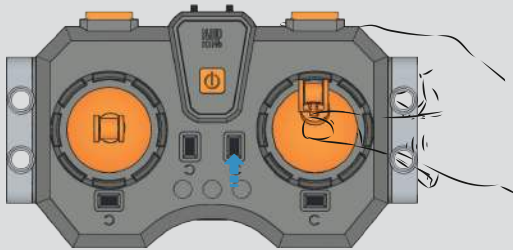

7

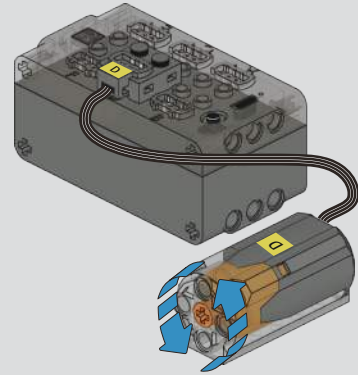
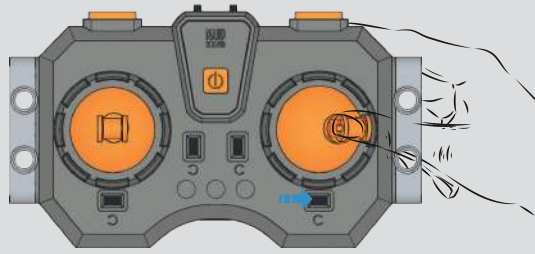

8

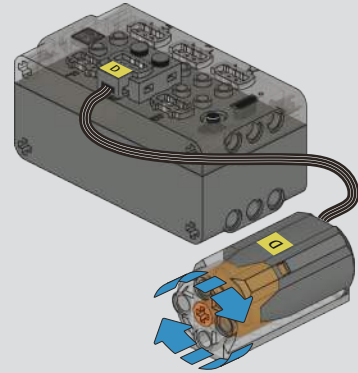
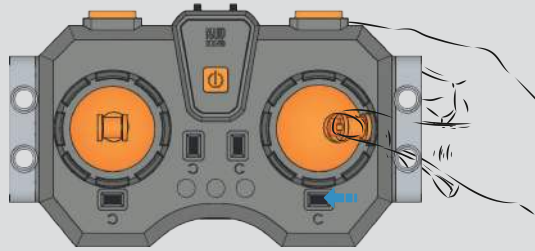

9

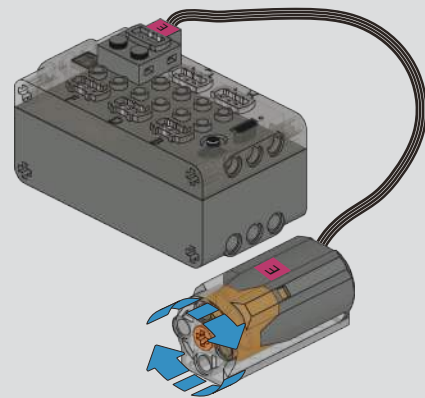
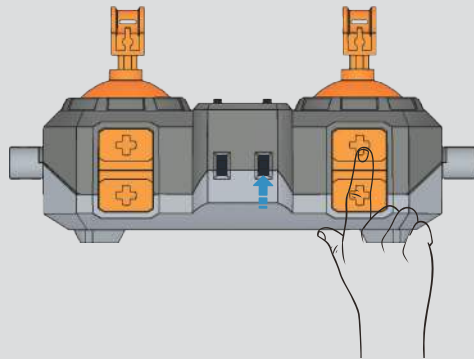

10

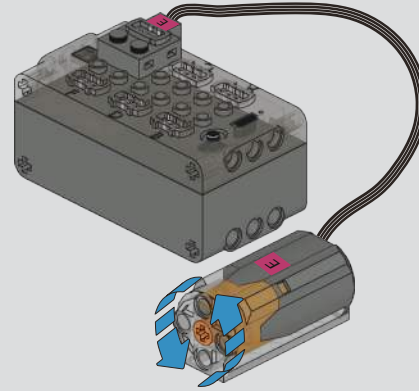
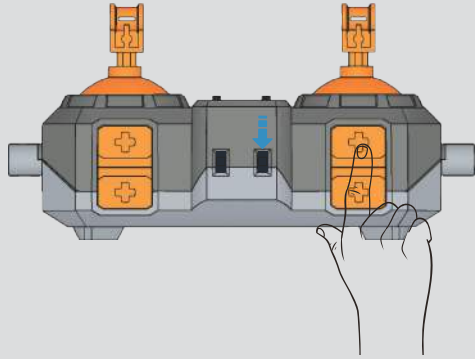

11

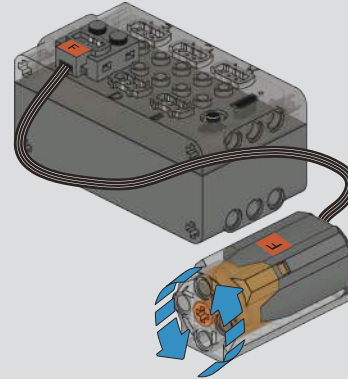
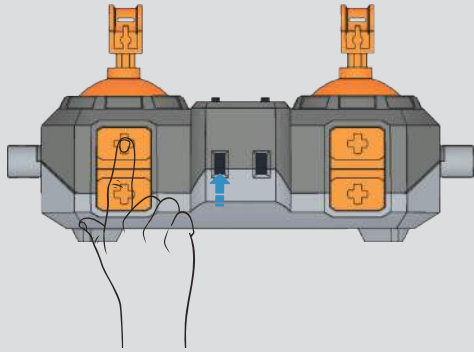

12

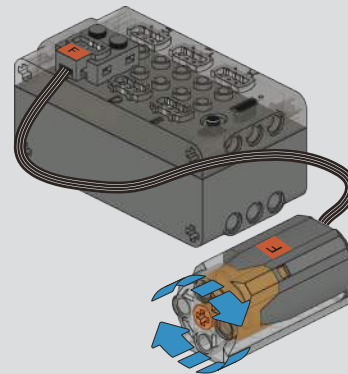
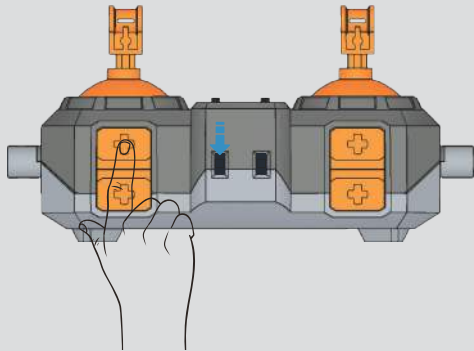

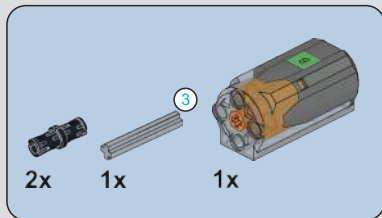
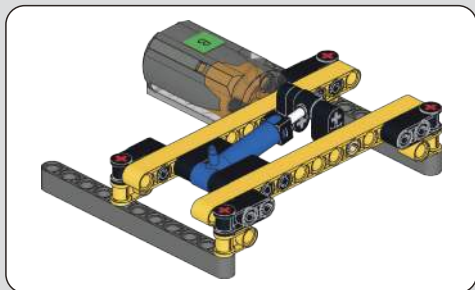

0-1

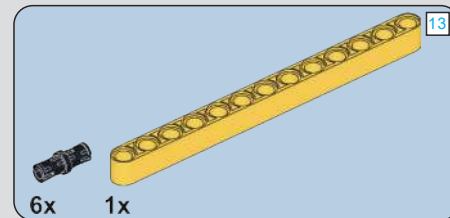

0-2

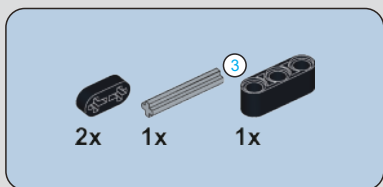
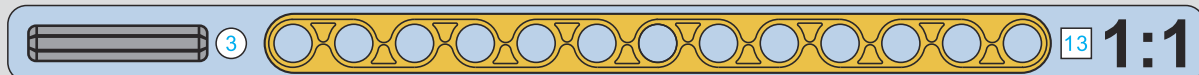
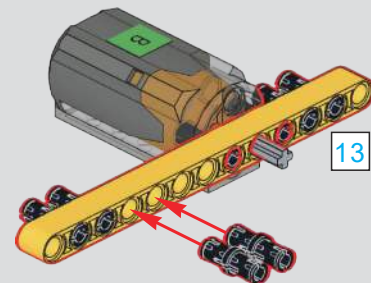
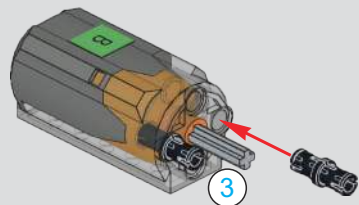

0-3

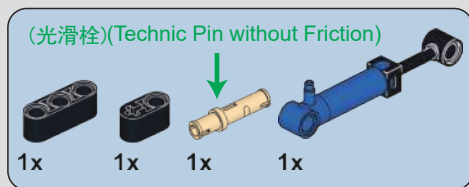

0-4

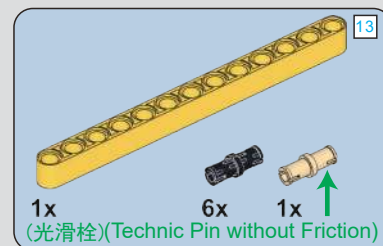

0-5

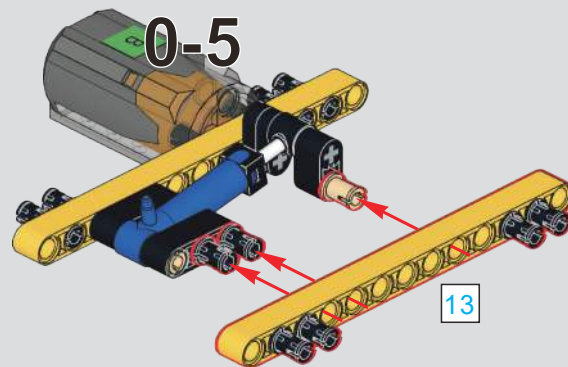
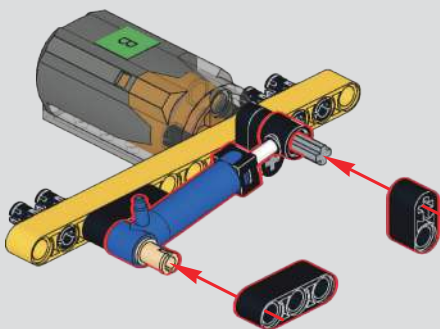
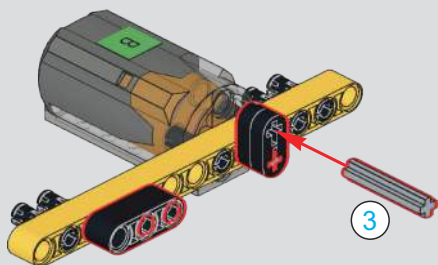

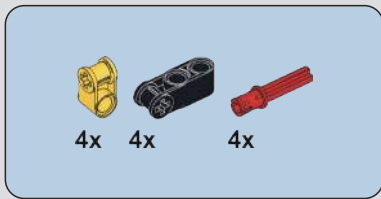

0-6

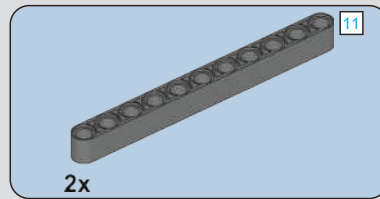
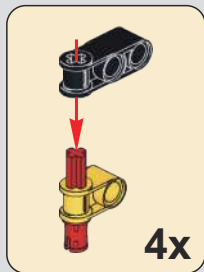
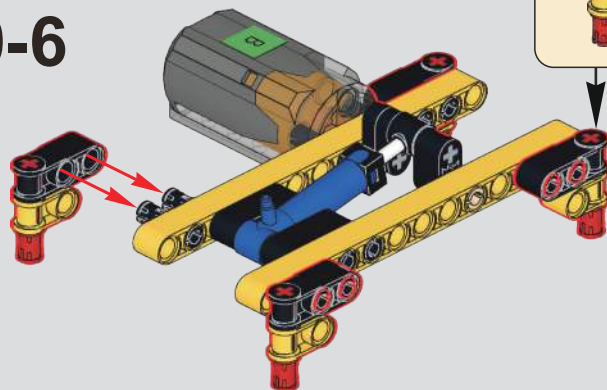

0-7

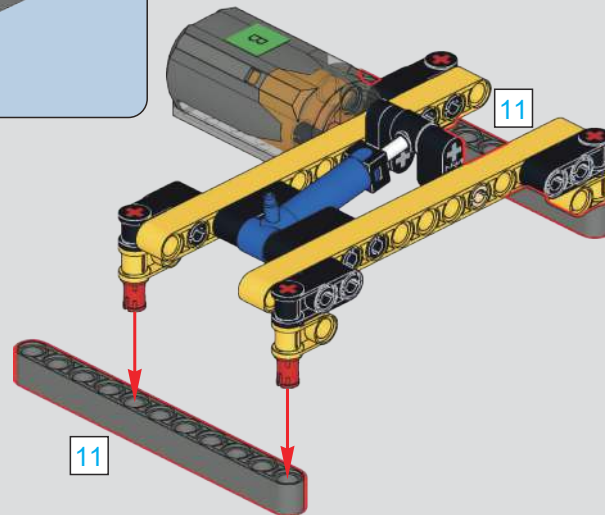

拼装前必须检测确认气泵，气挺杆，控制开关正常工作。测试完请将零件拆开，拼装需要用到。
 Before assembly, the air pump, air lifter, and control switch must be checked and confirmed to work normally. Please disassemble the parts after testing.

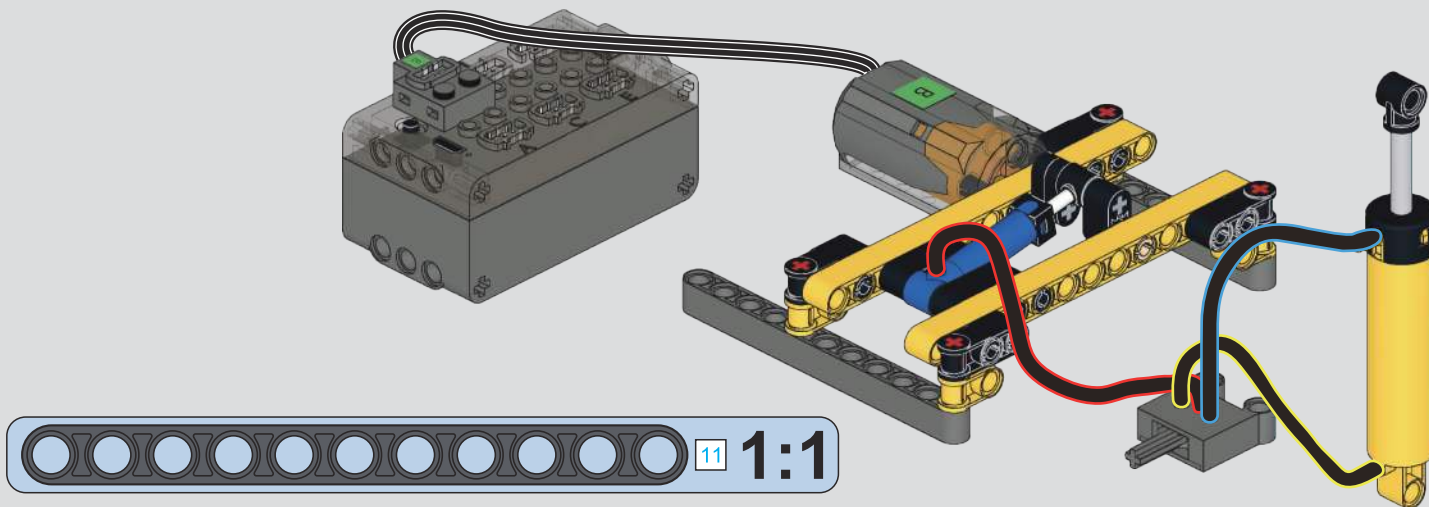

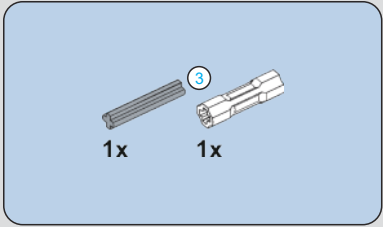
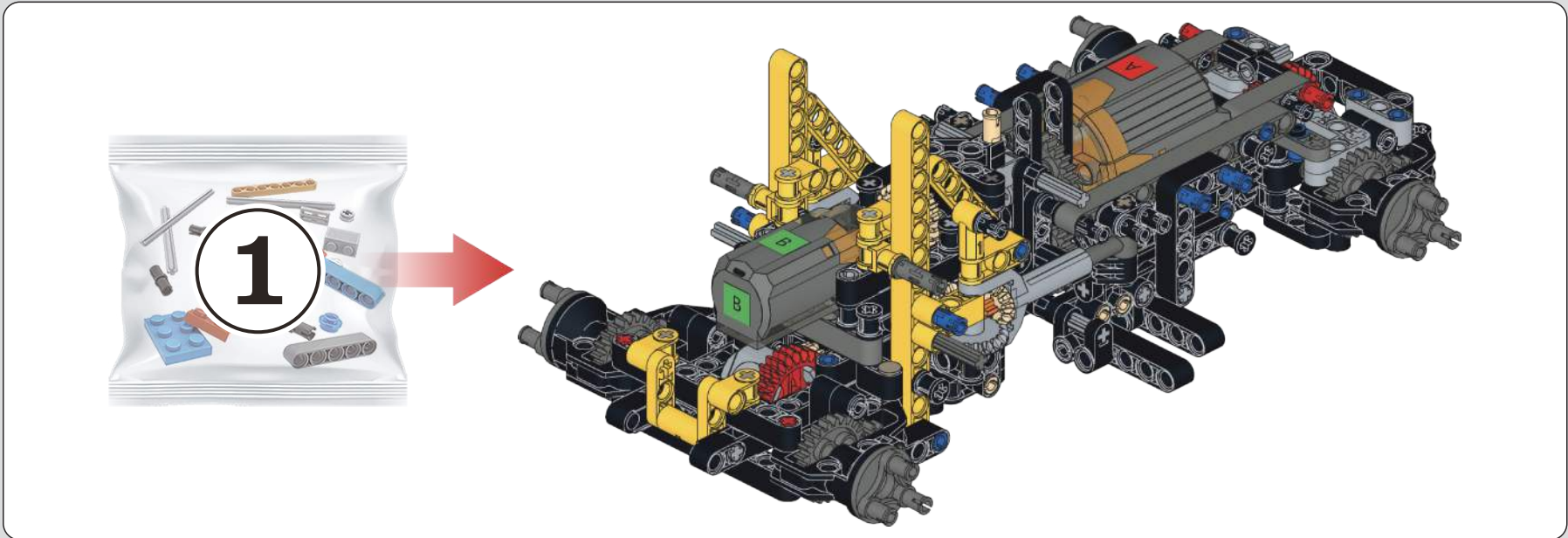

1

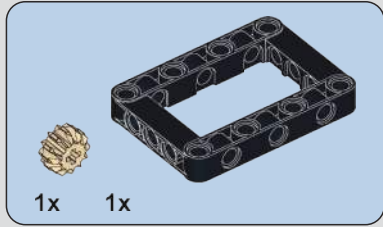
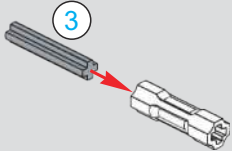

2

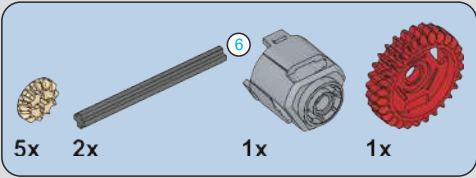
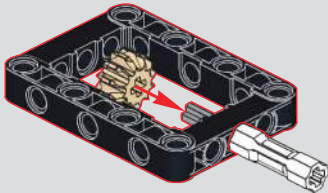

3

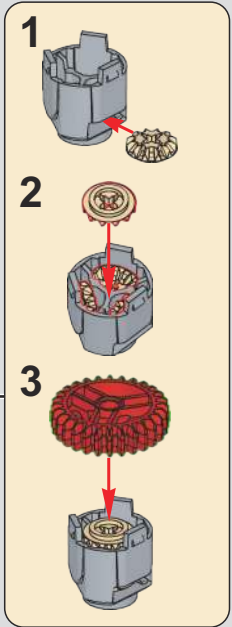
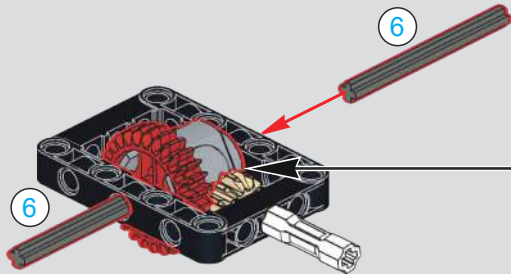

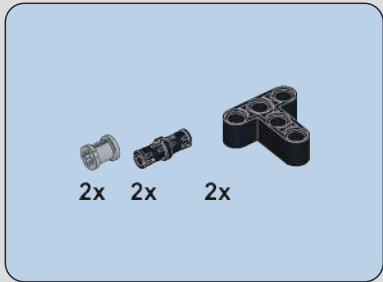

4

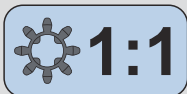
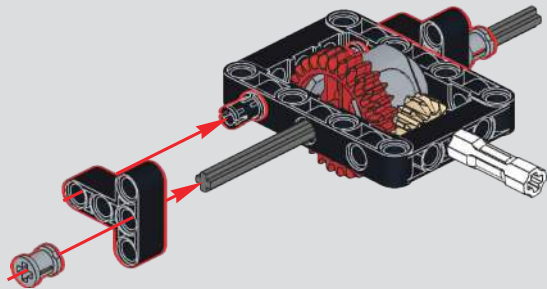

2

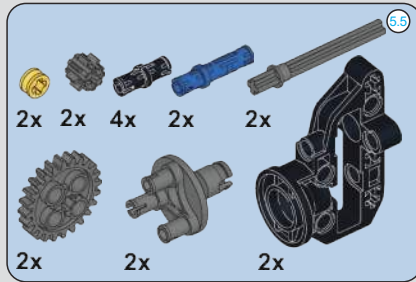

5

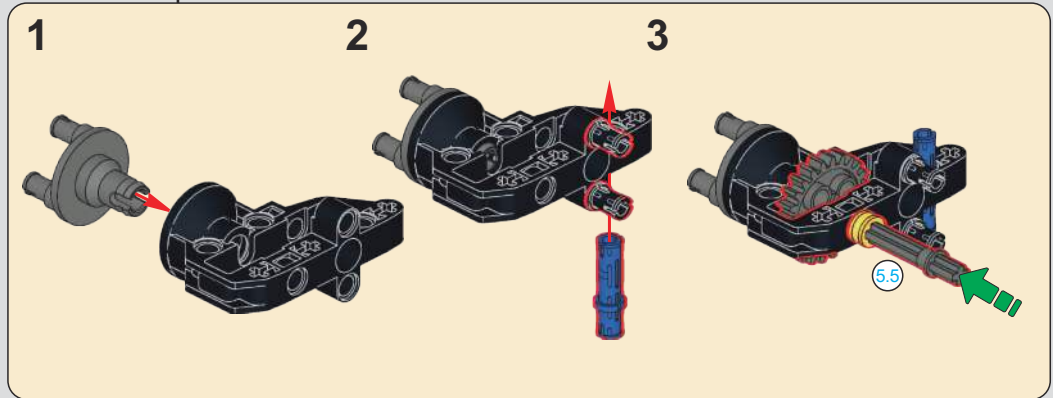
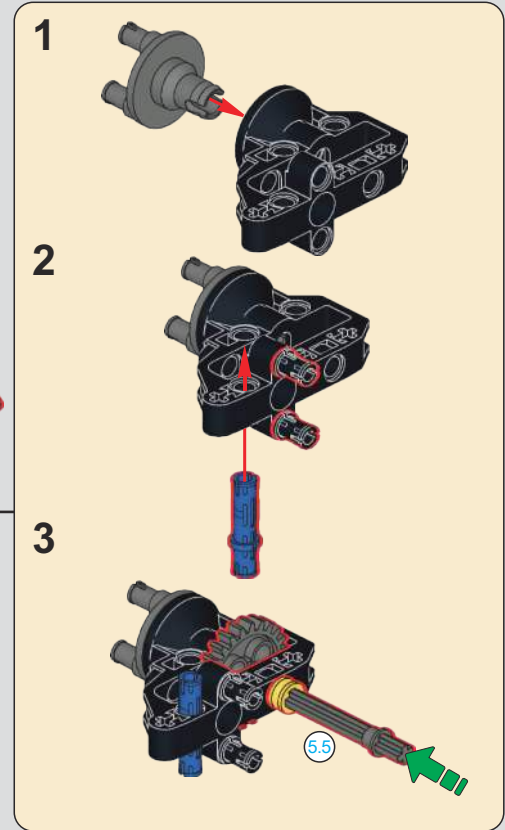
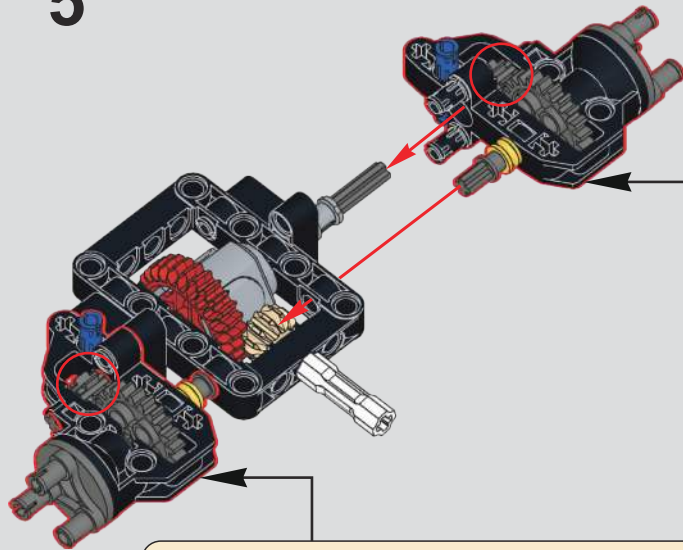

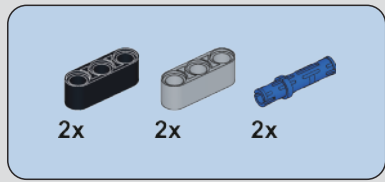

6

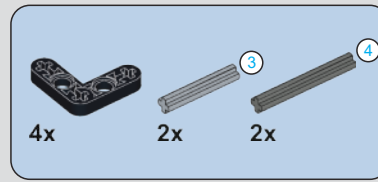
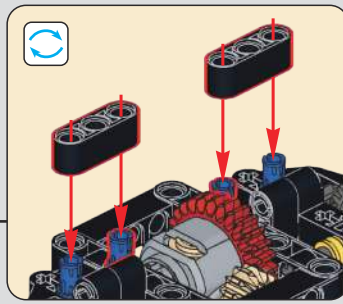
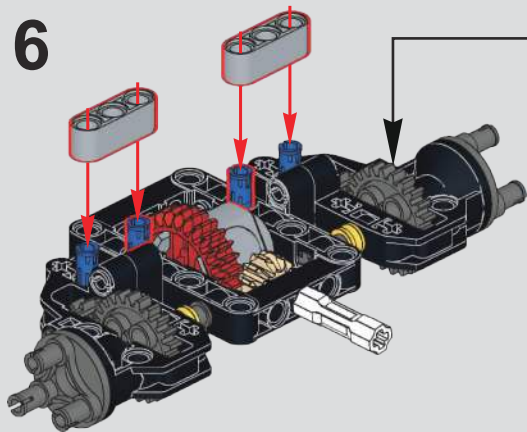

7

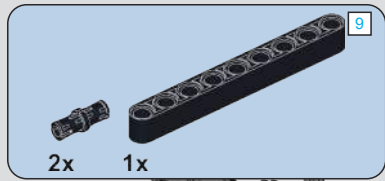
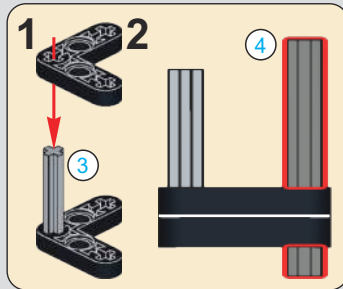
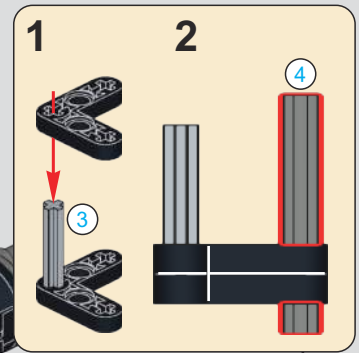
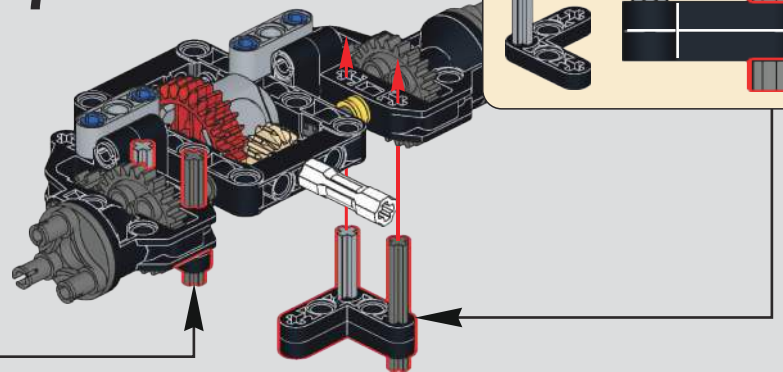

8

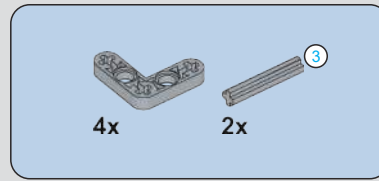
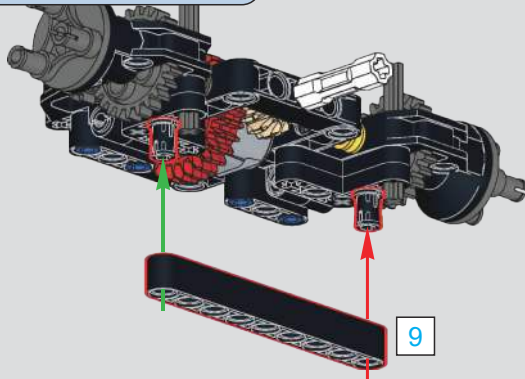

9

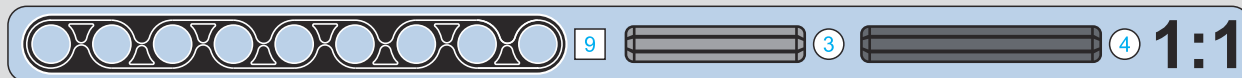
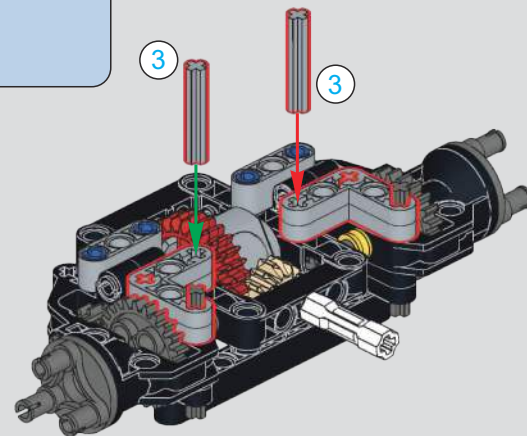

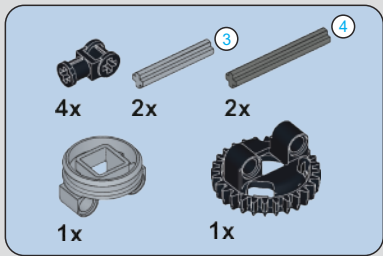

10

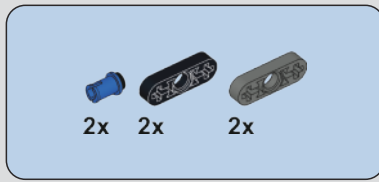
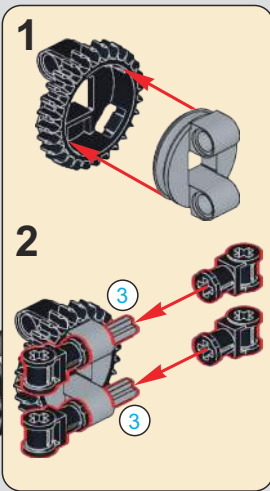
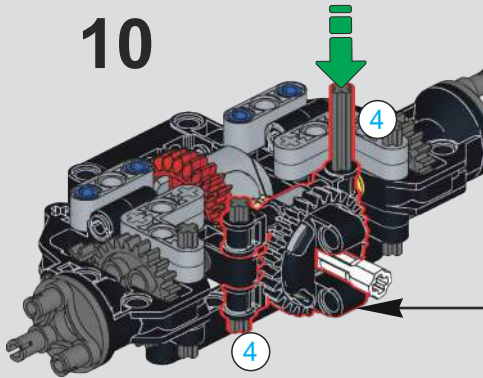

11

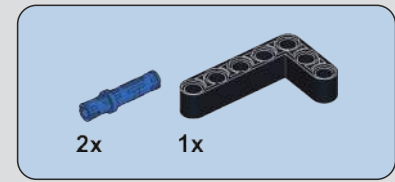
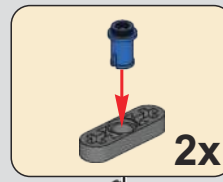
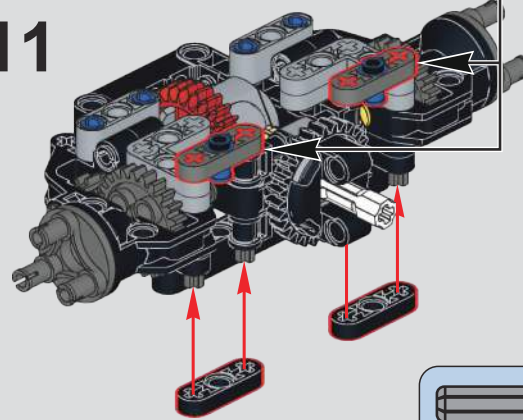

12

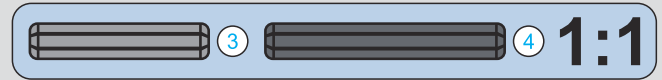
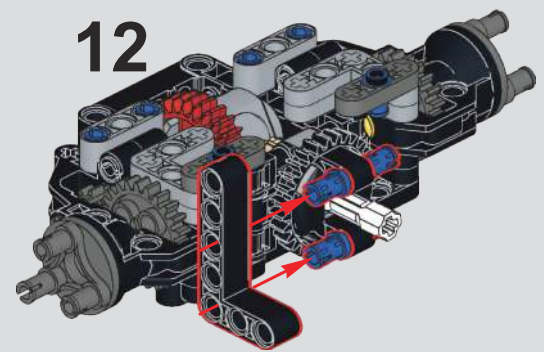

13

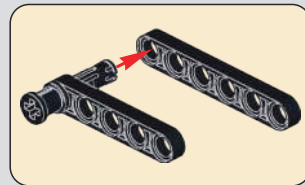
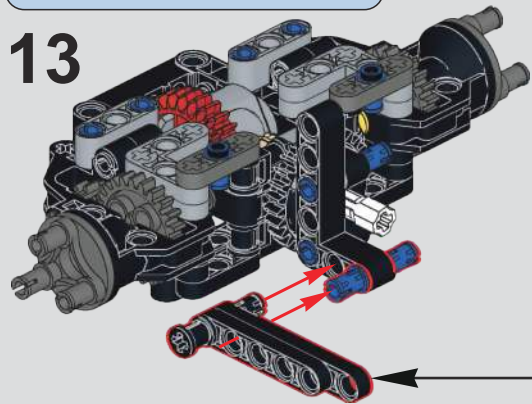

14

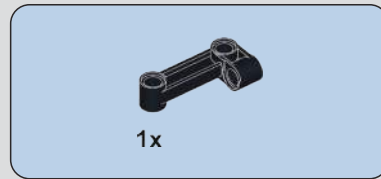
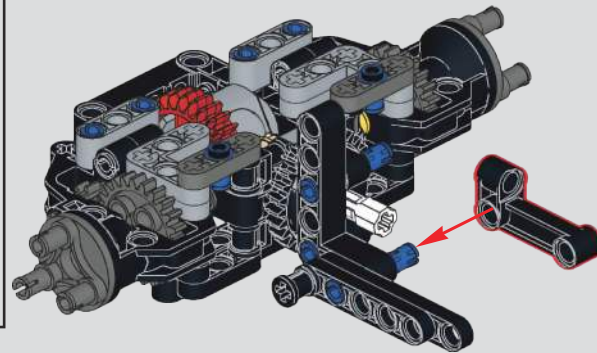

15

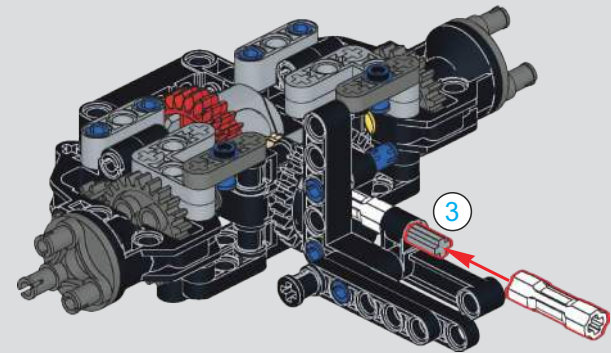
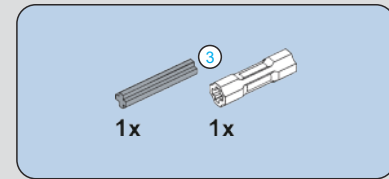

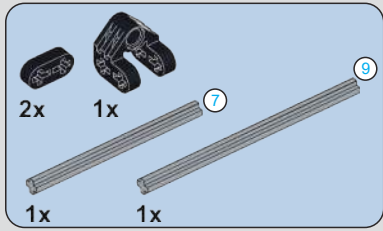

16

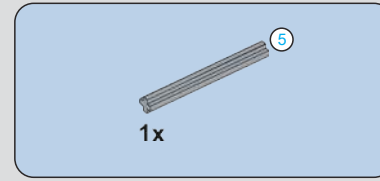
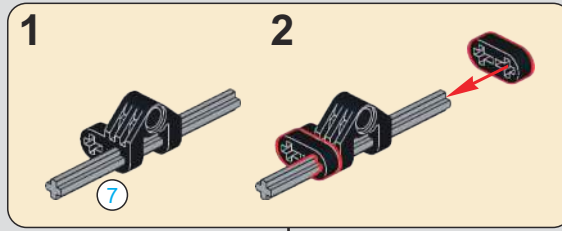
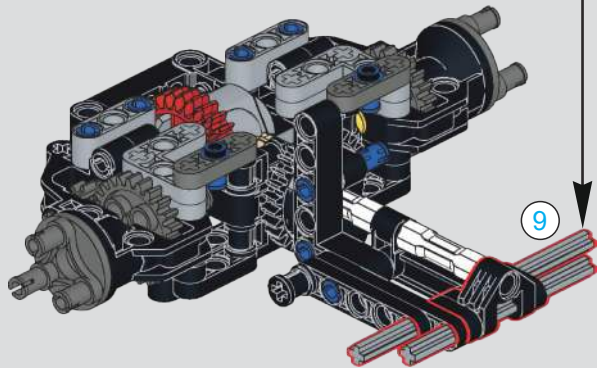

17

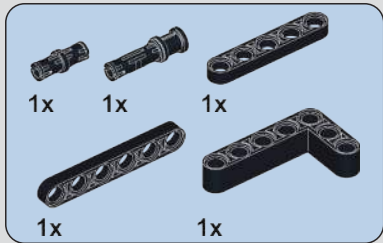
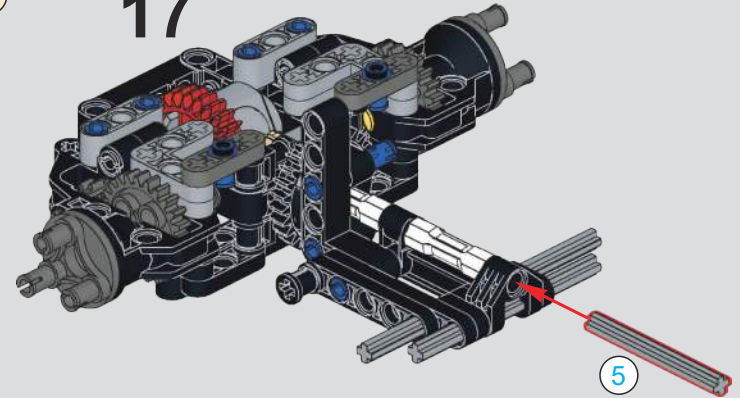

18

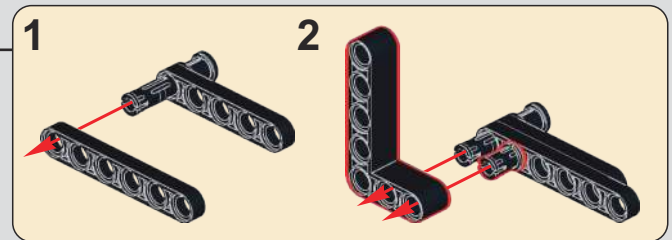
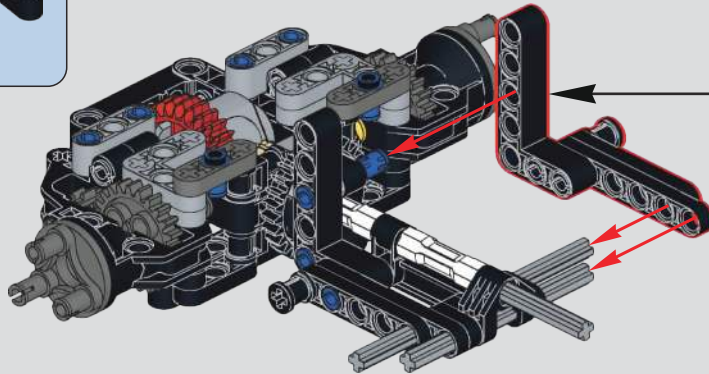



19

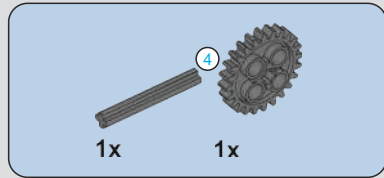
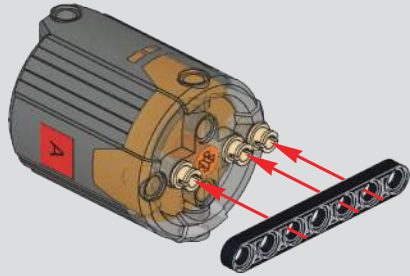

20

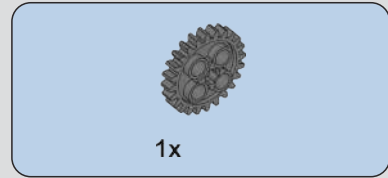
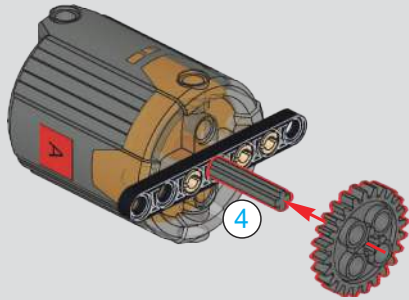

21

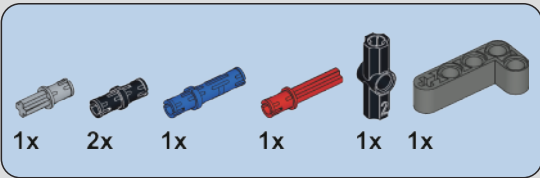
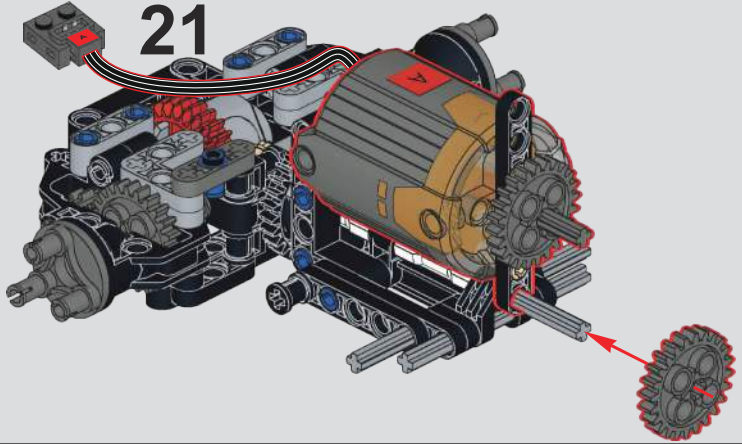

22

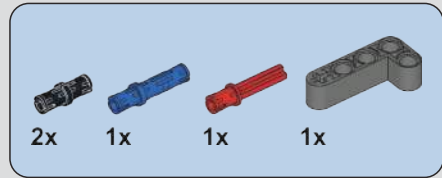
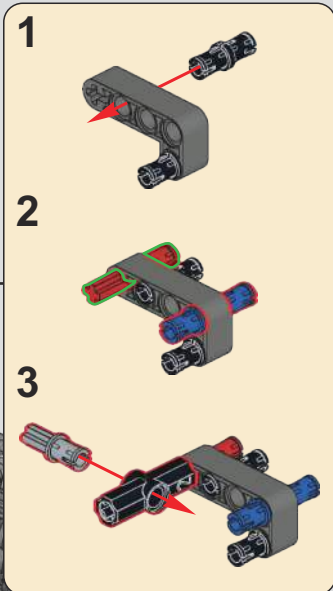
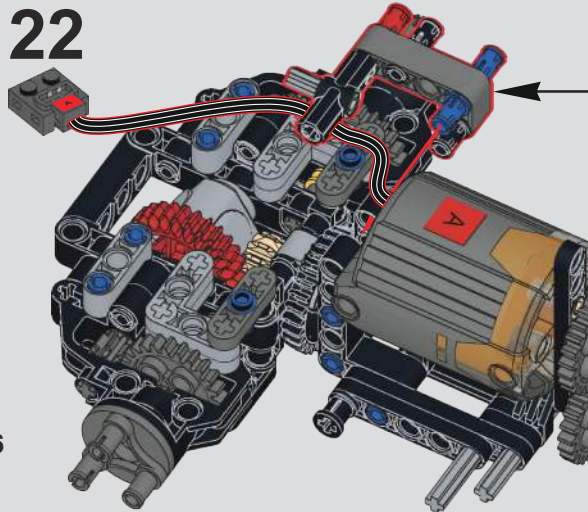

23

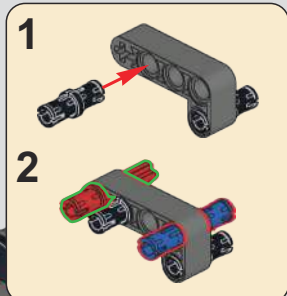
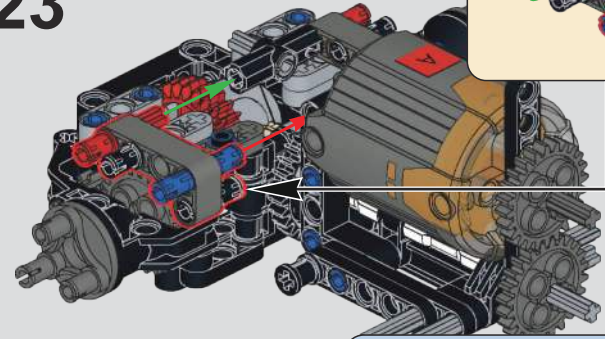

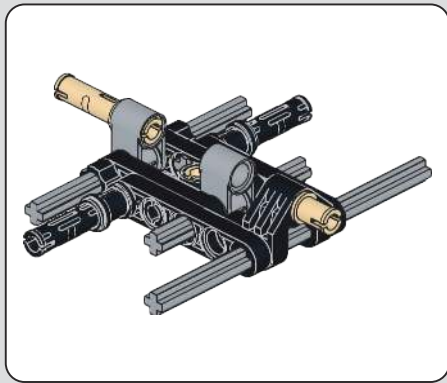
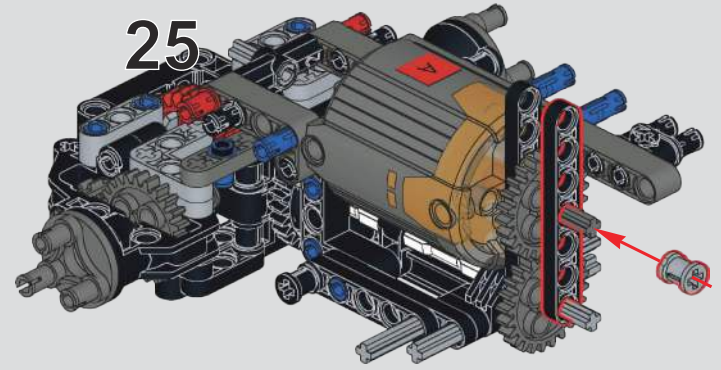
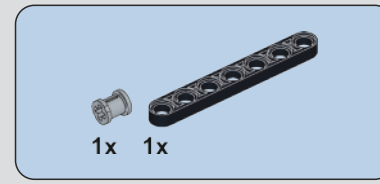
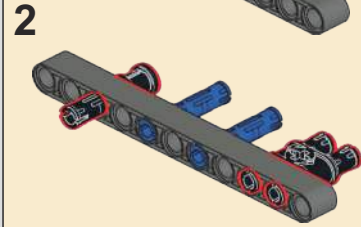
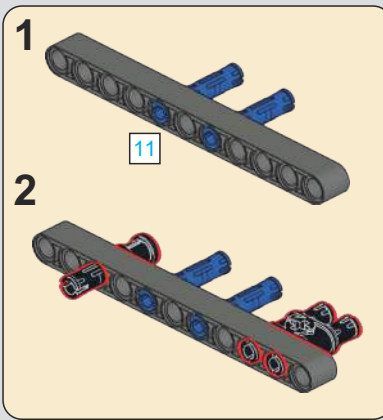
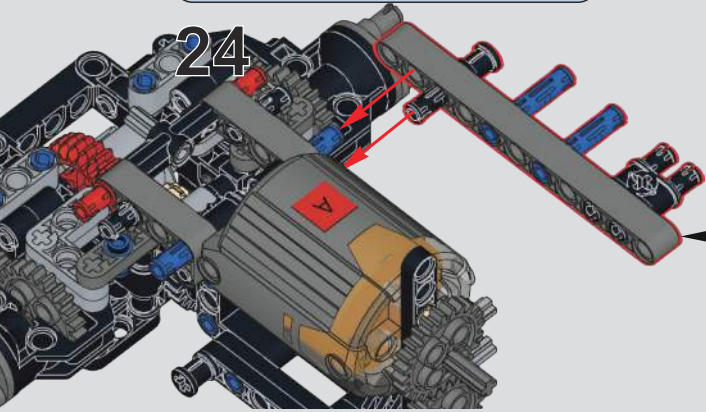
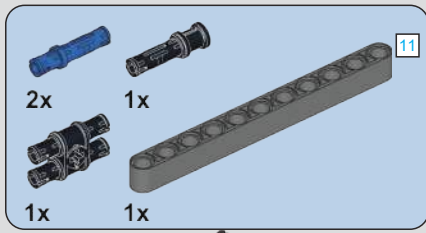

26

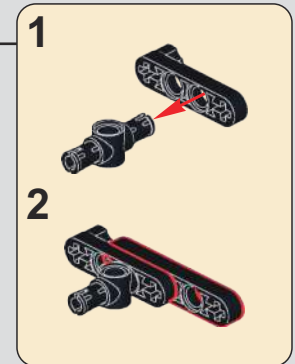
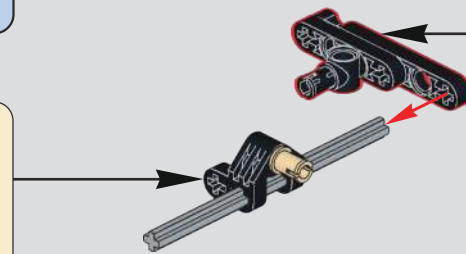
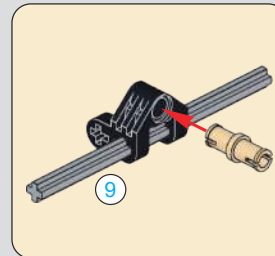

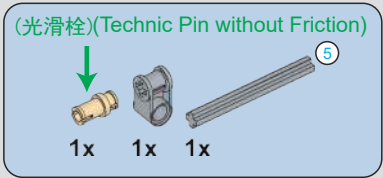

27

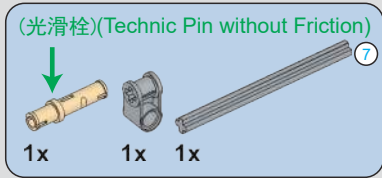
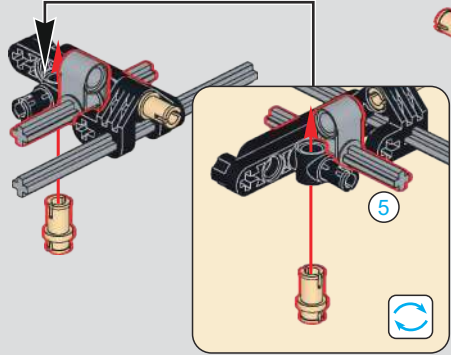

28

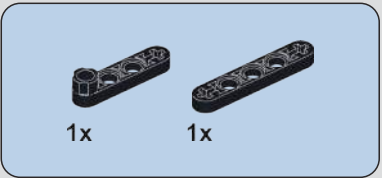
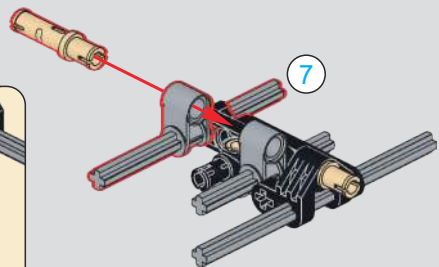

29

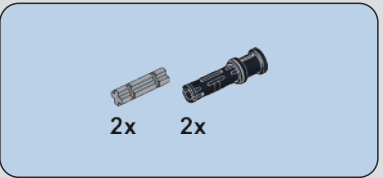
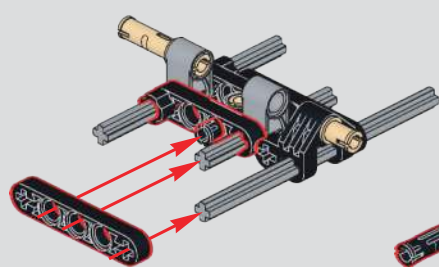

30

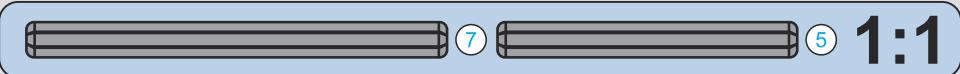
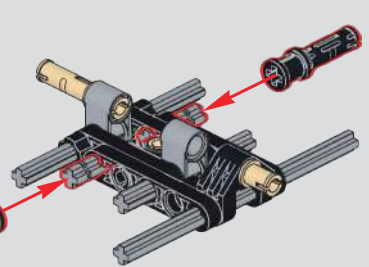

31

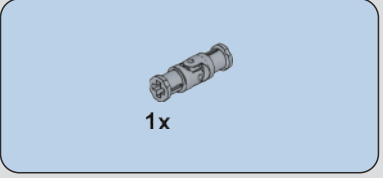
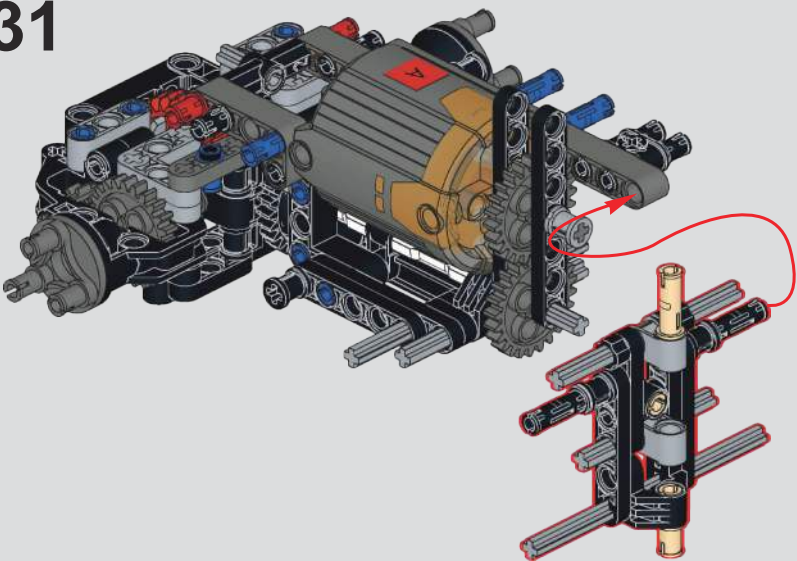

32

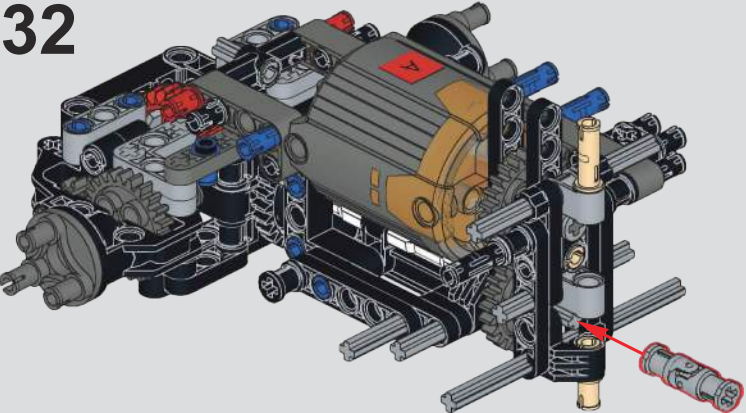

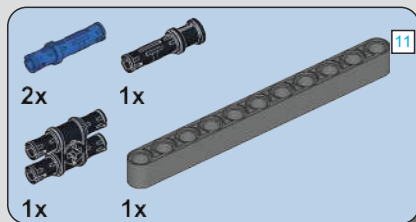

33

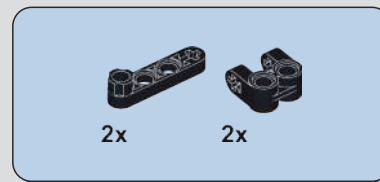
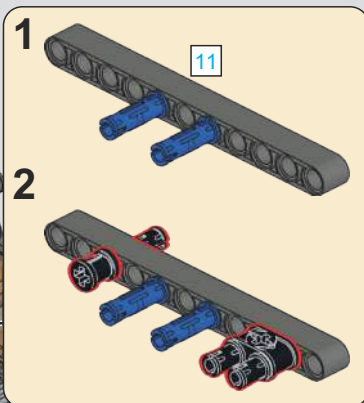

34

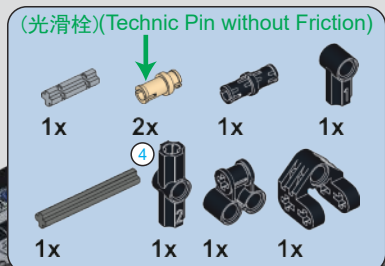

35

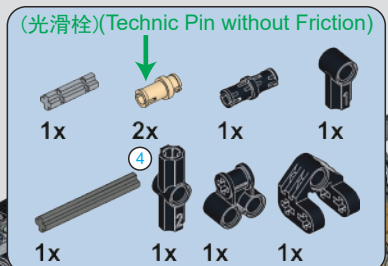
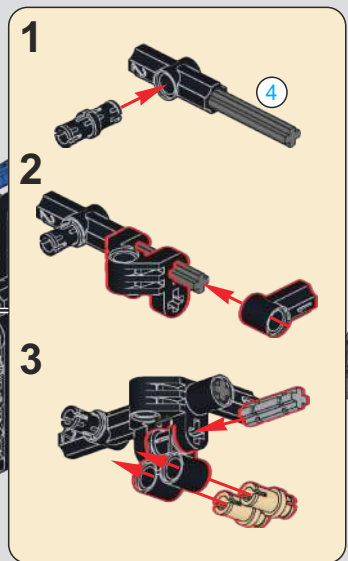

36

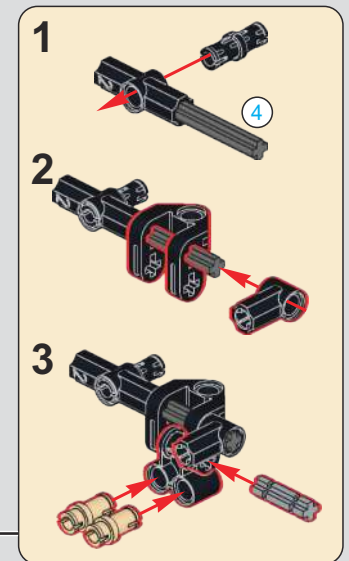

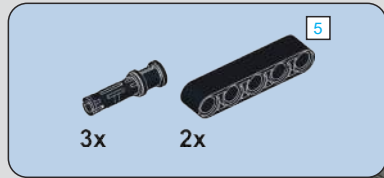

37

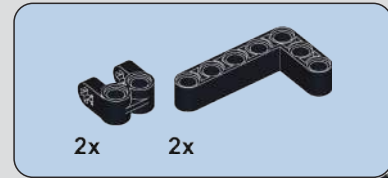
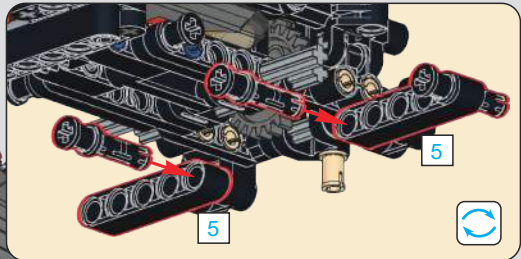

38

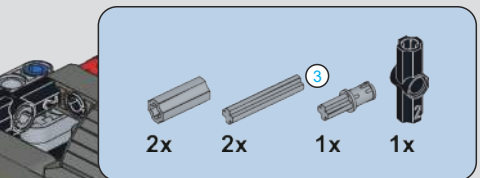
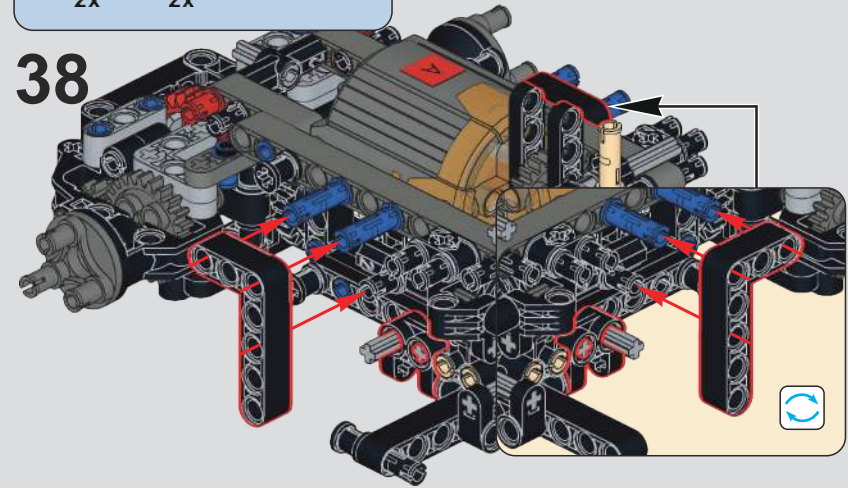

39

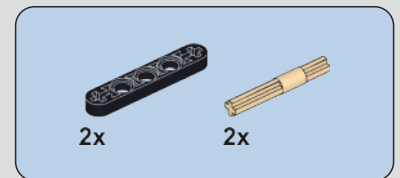
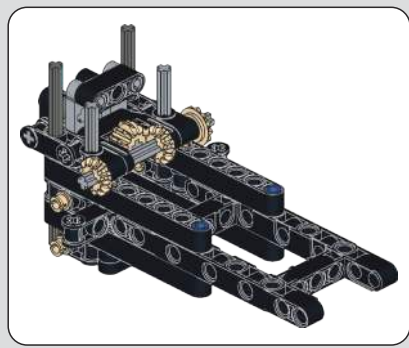
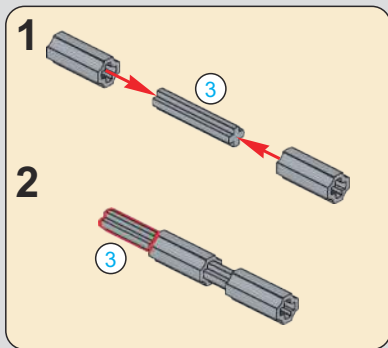

40

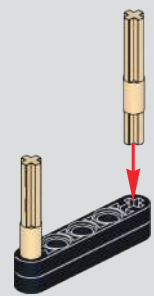

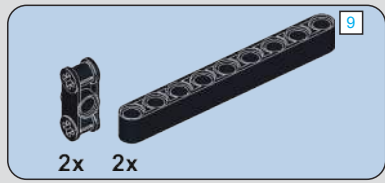

41

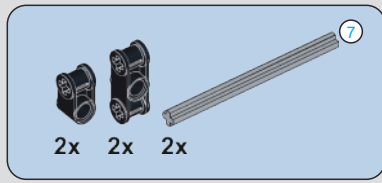
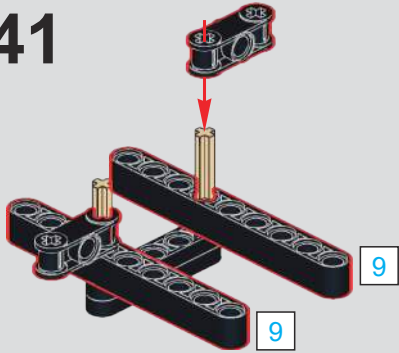

42

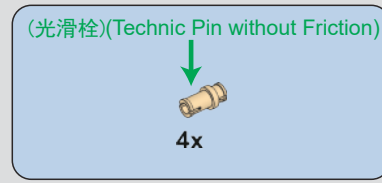
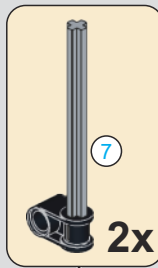
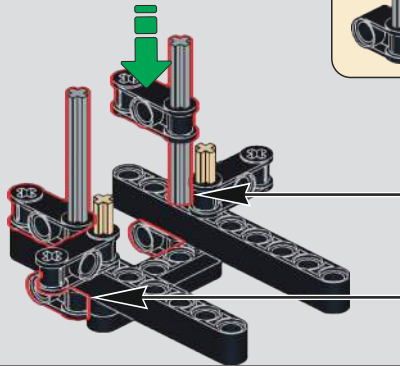

43

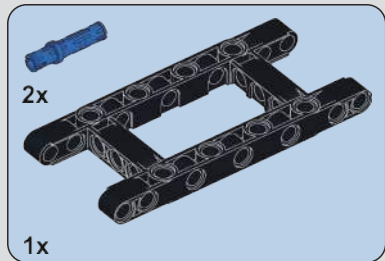
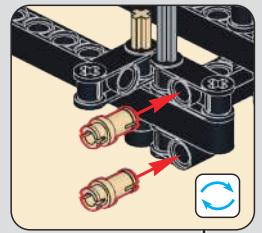
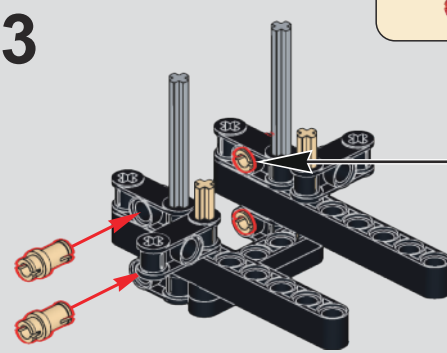

44

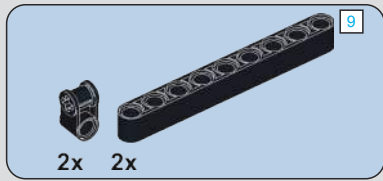
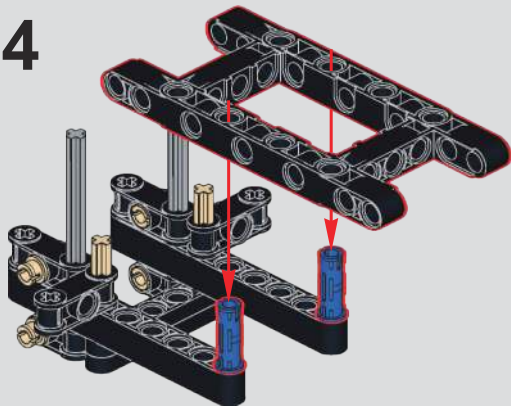

45

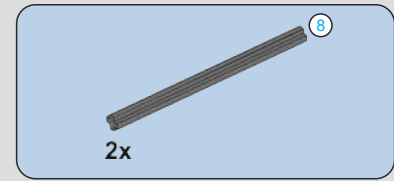
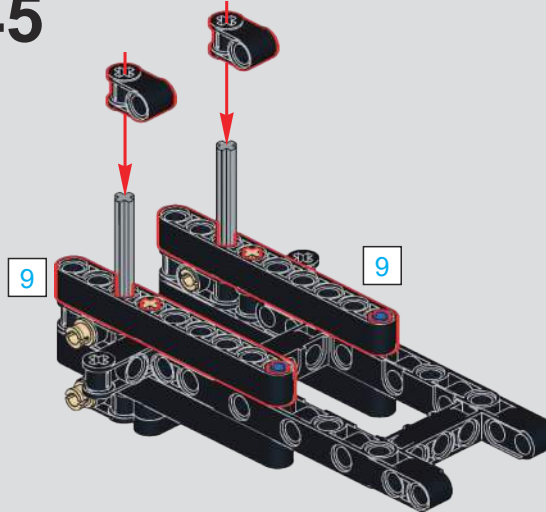

46

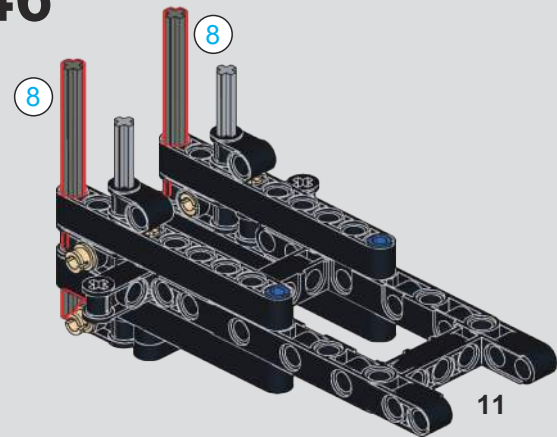

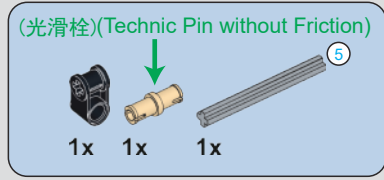
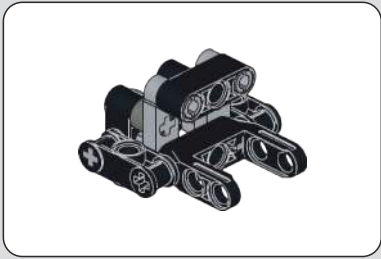

47

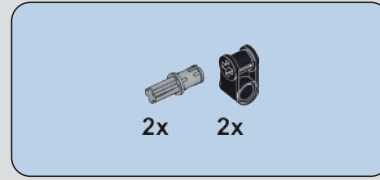

48

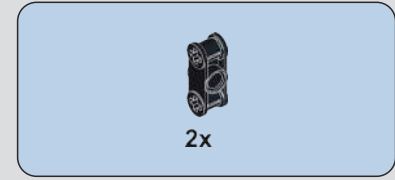

49

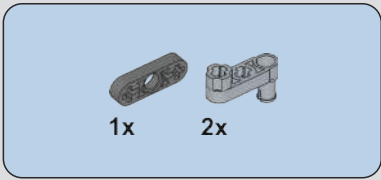
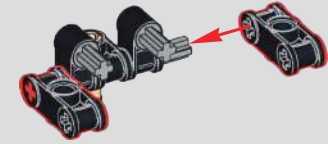
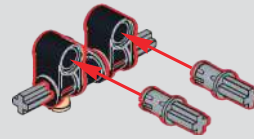
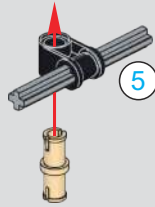

50

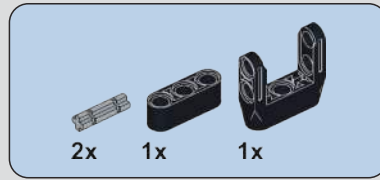

51

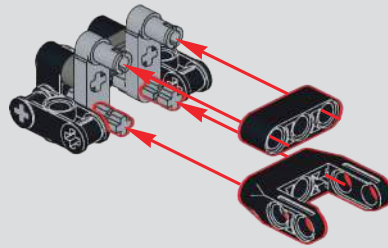
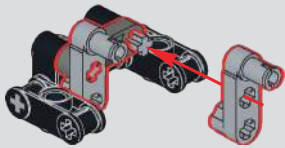

52

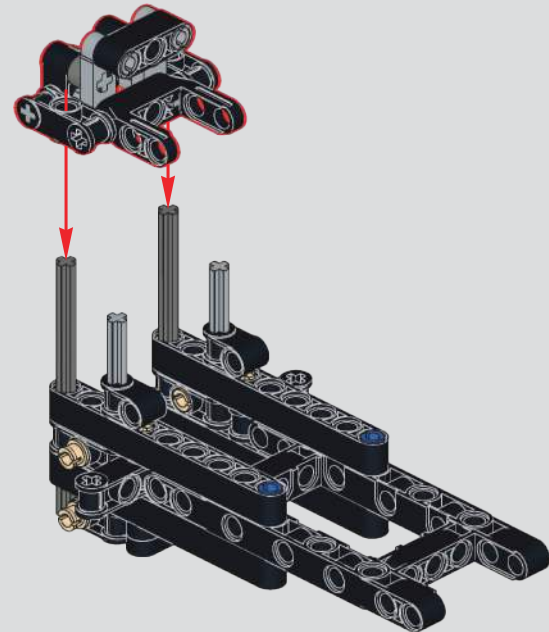

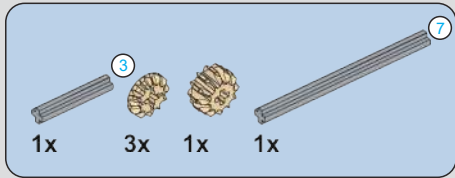

54

53

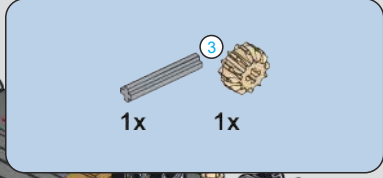
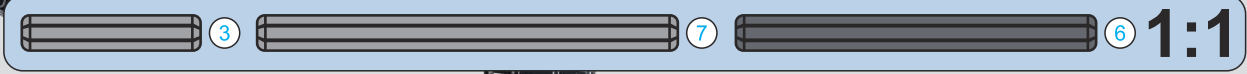
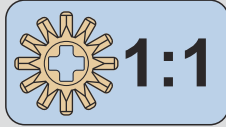
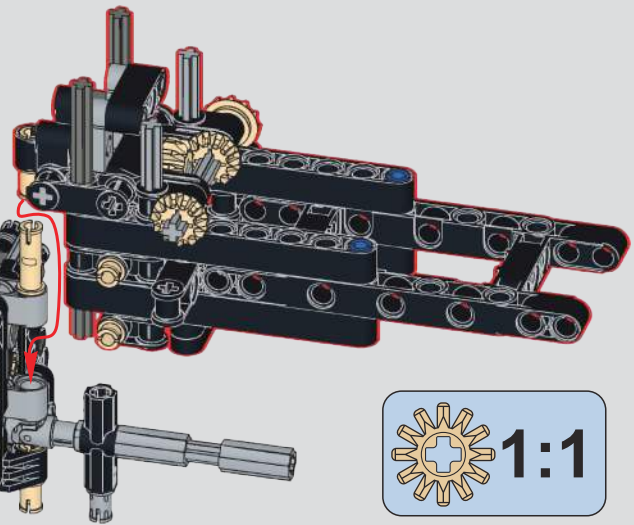
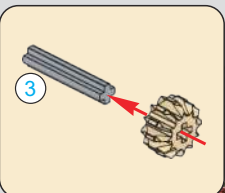
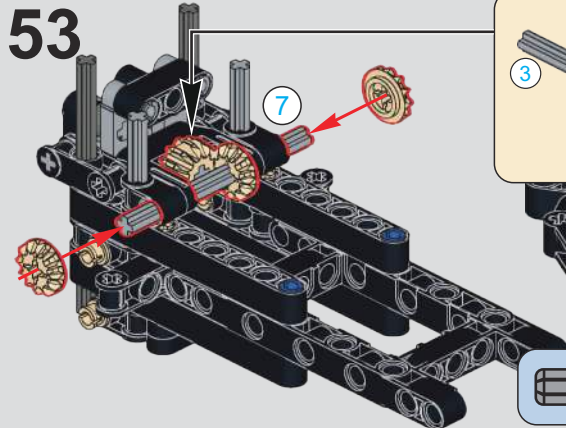

55

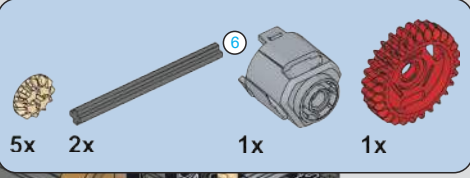
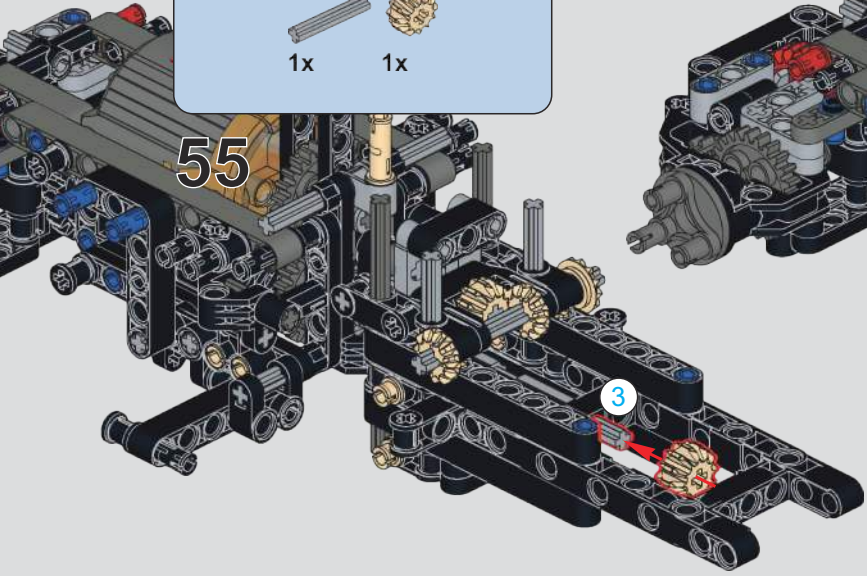

56

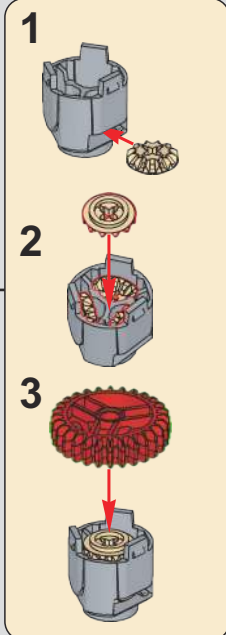
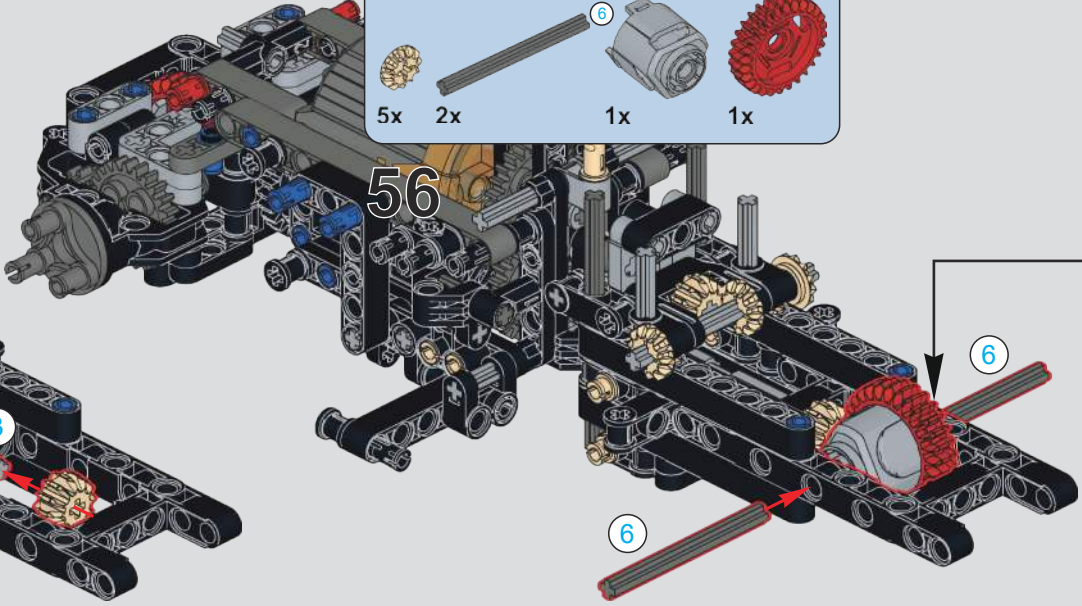

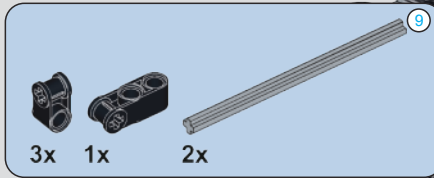

57

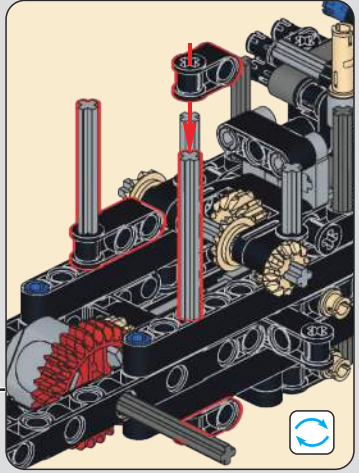
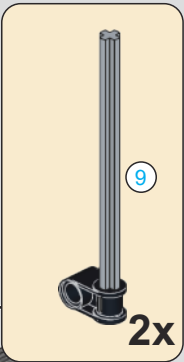
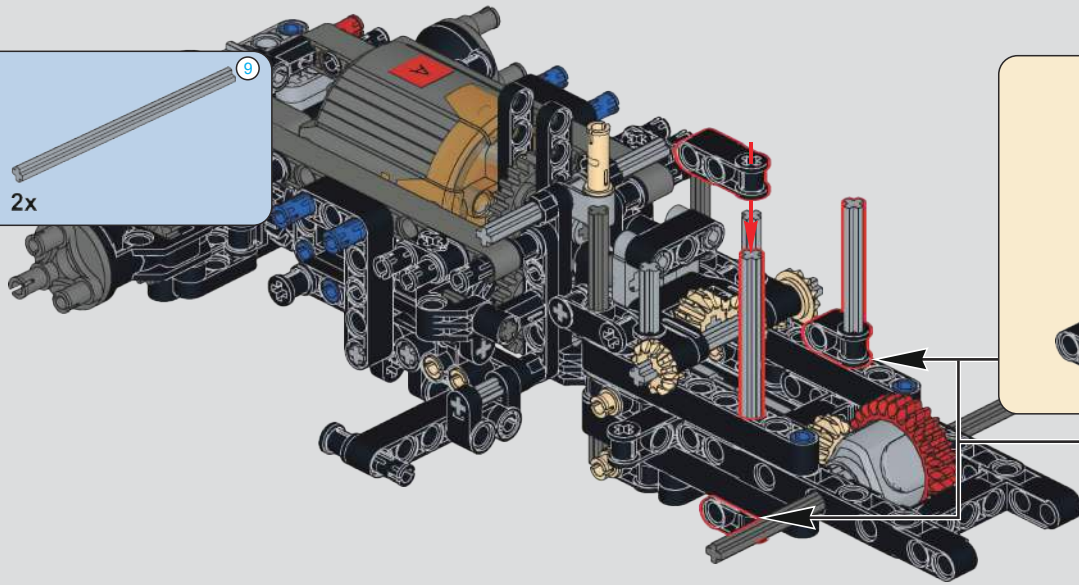

58

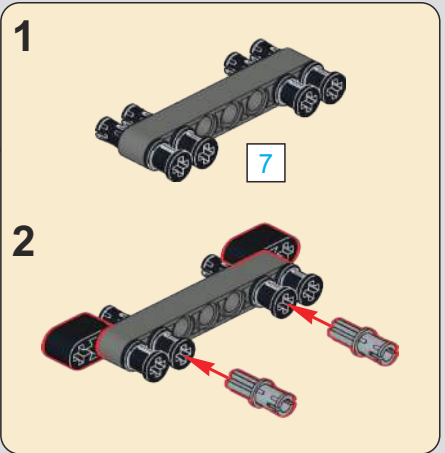
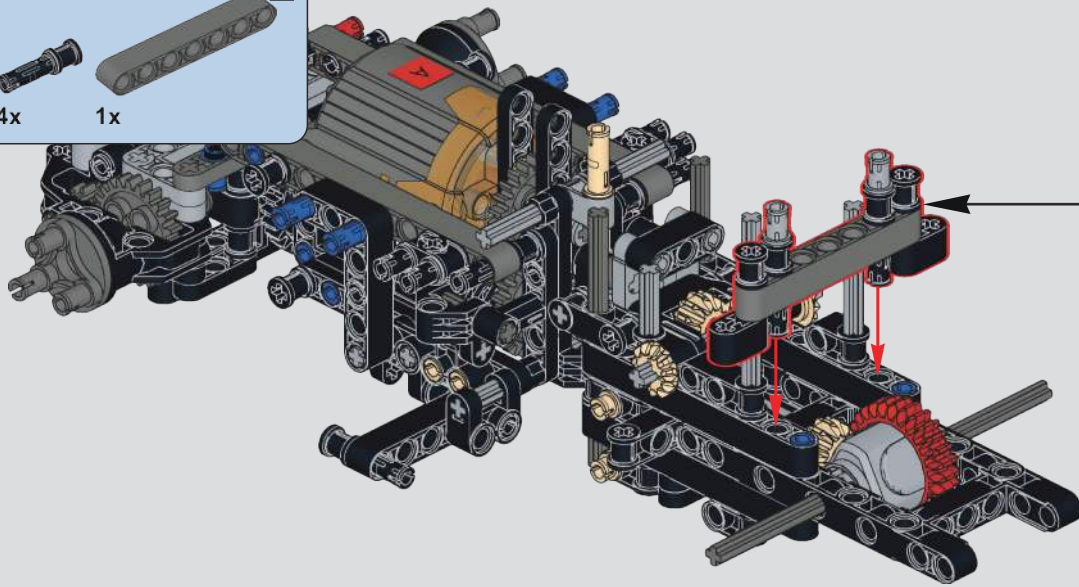

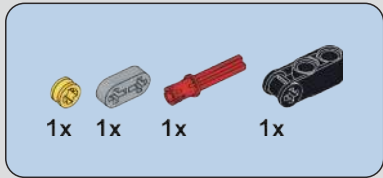

59

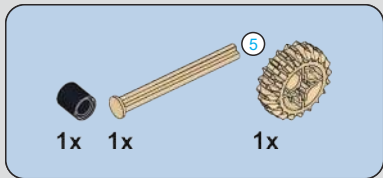
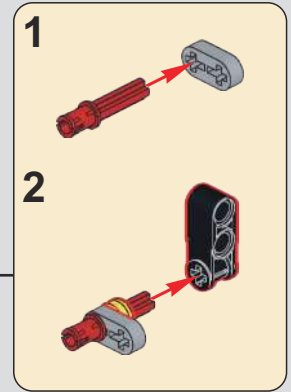
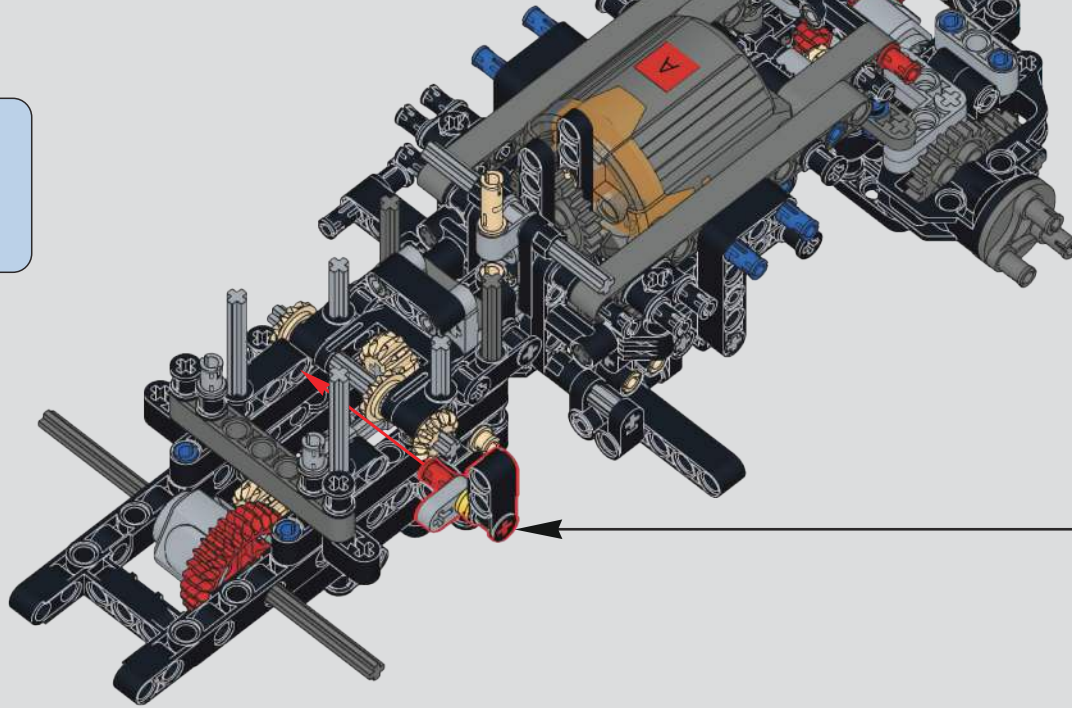

60

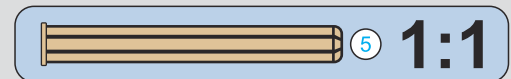
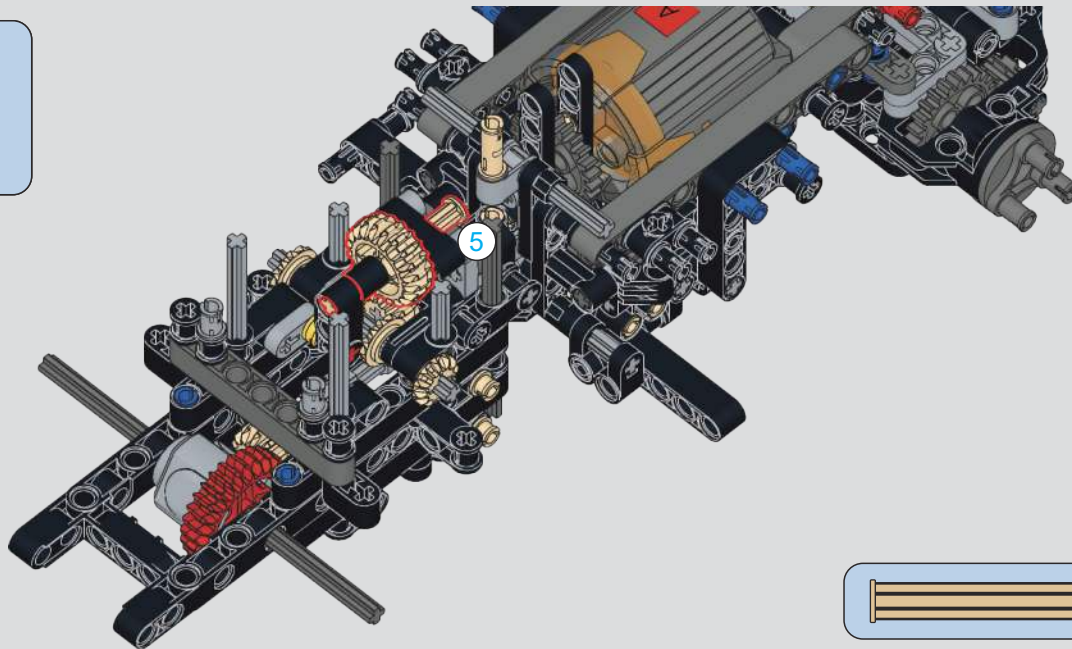

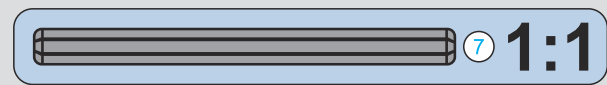
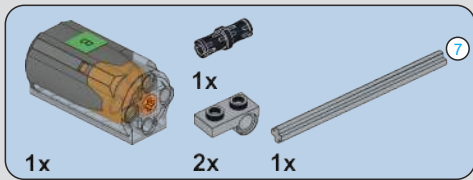

61

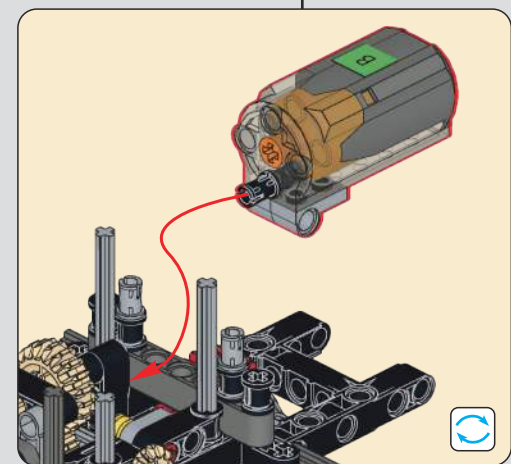
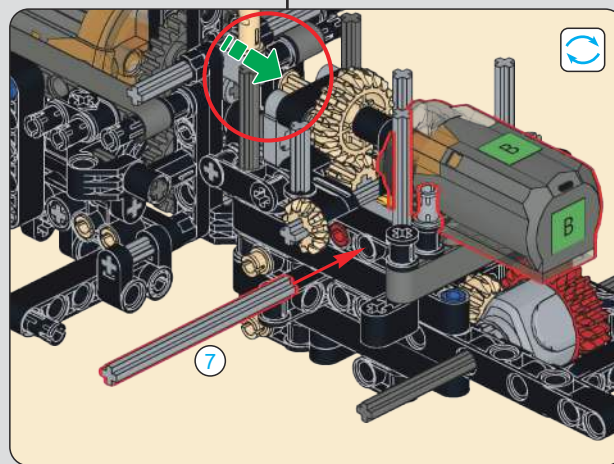
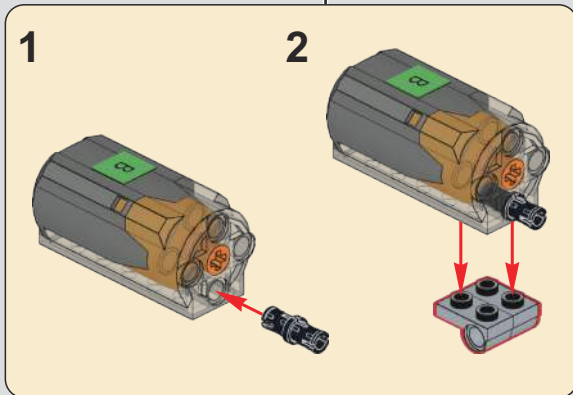
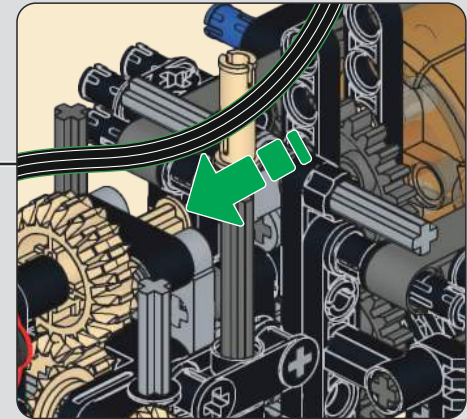
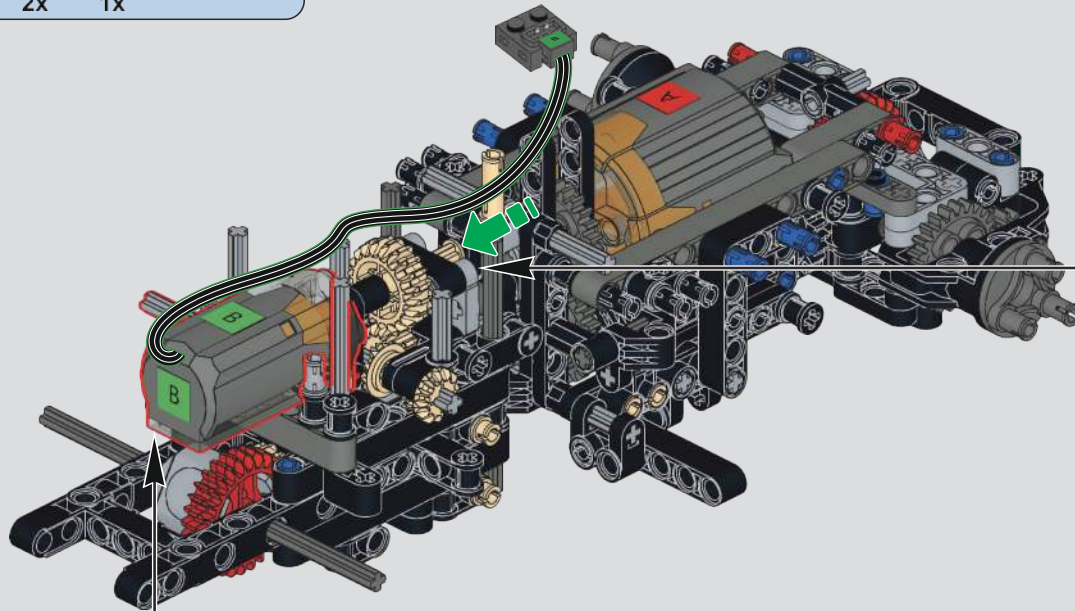

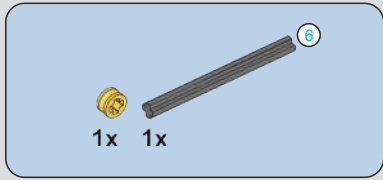

62

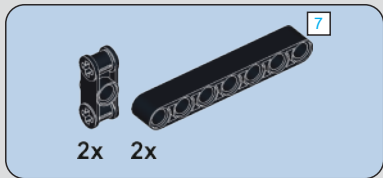
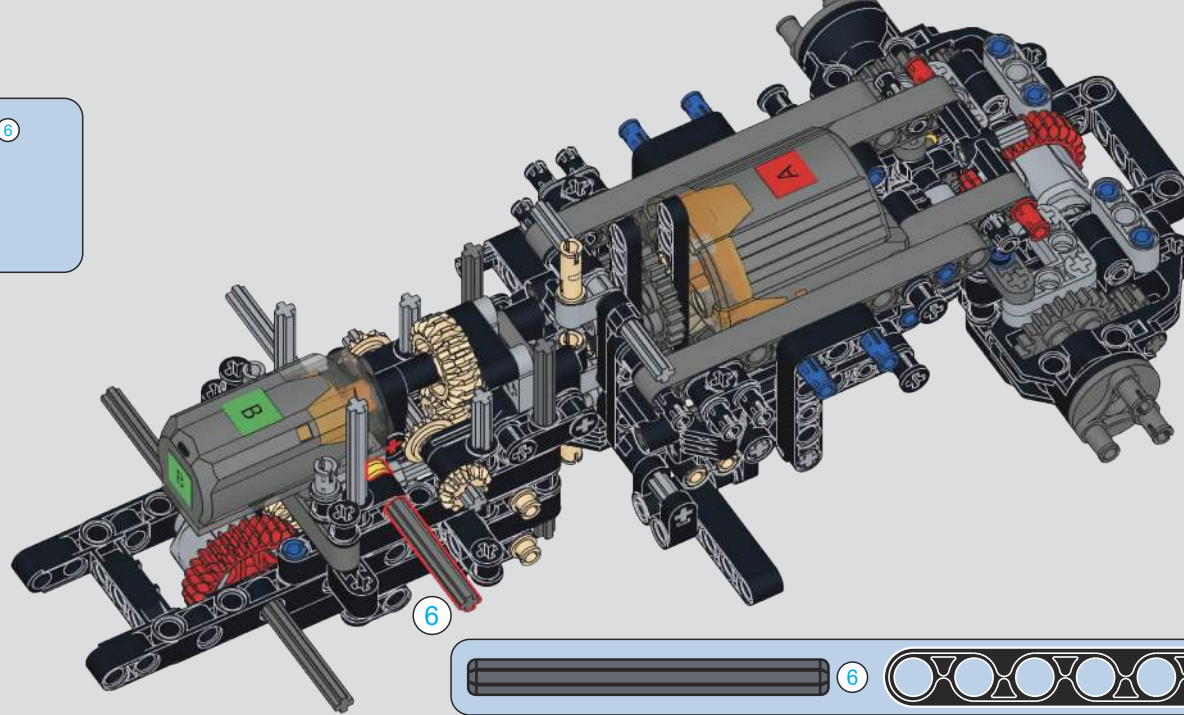

63

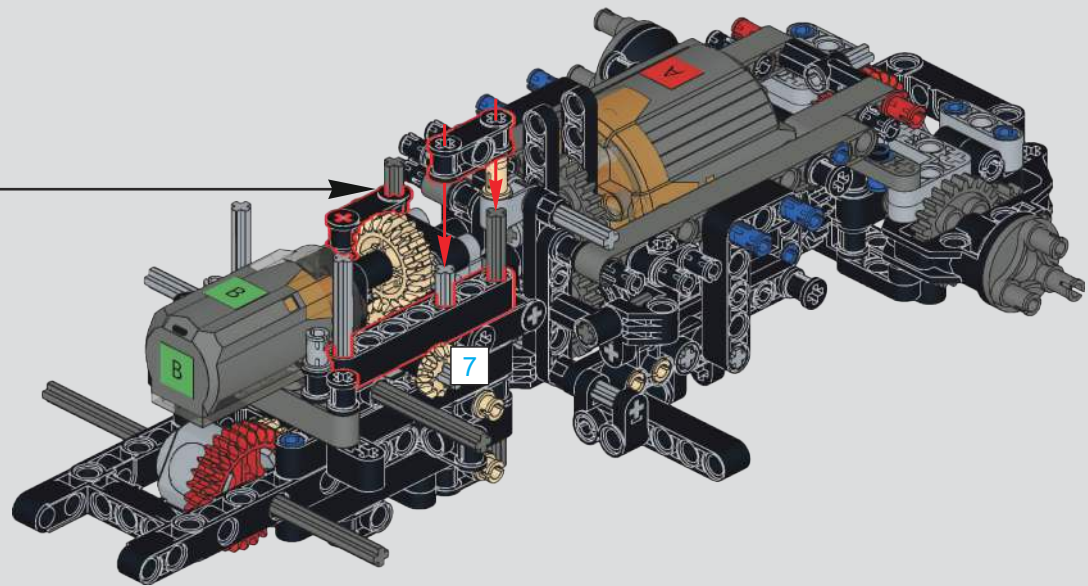
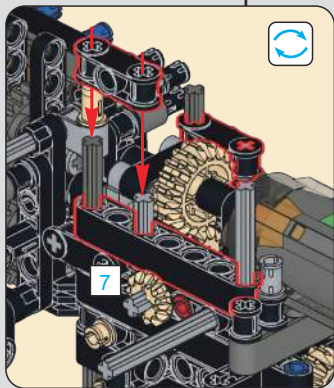

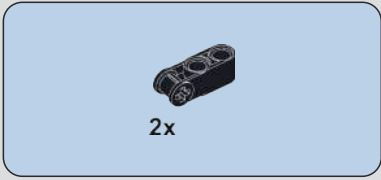

64

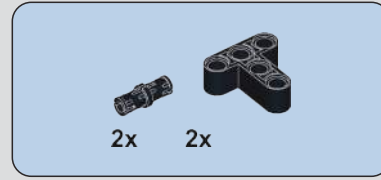
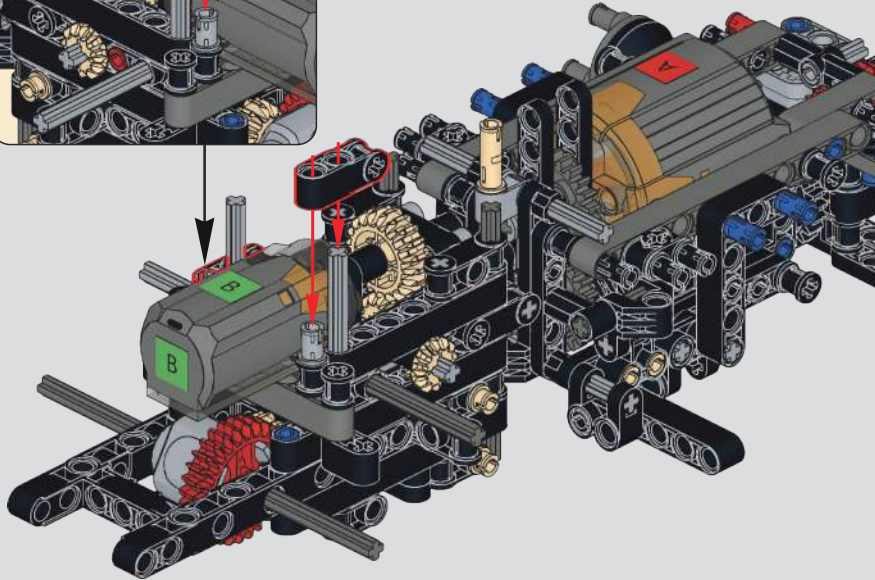
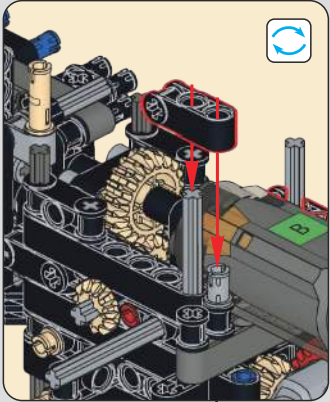

65

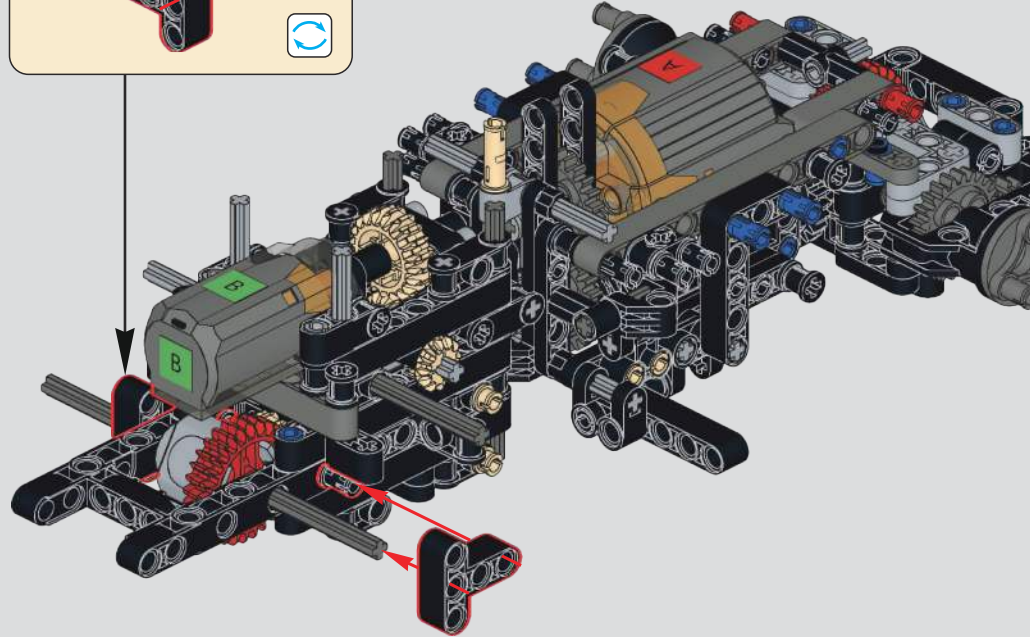
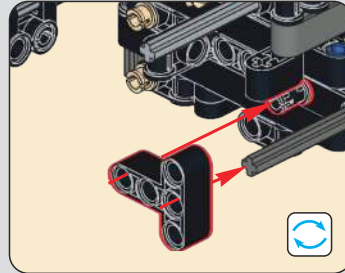

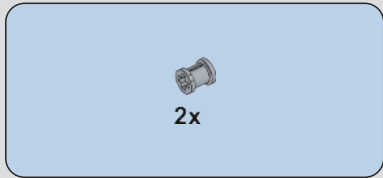

66

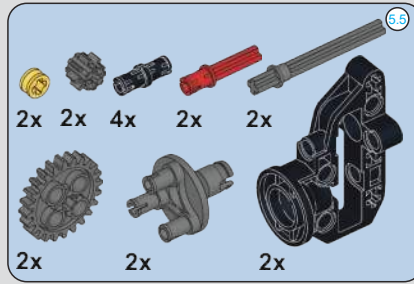
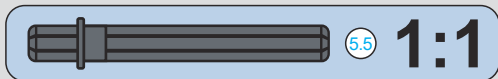
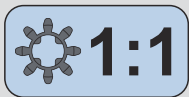
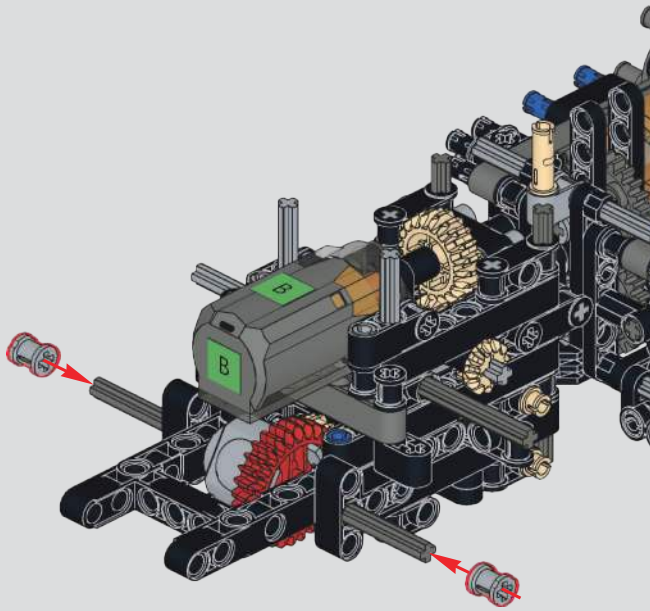

67

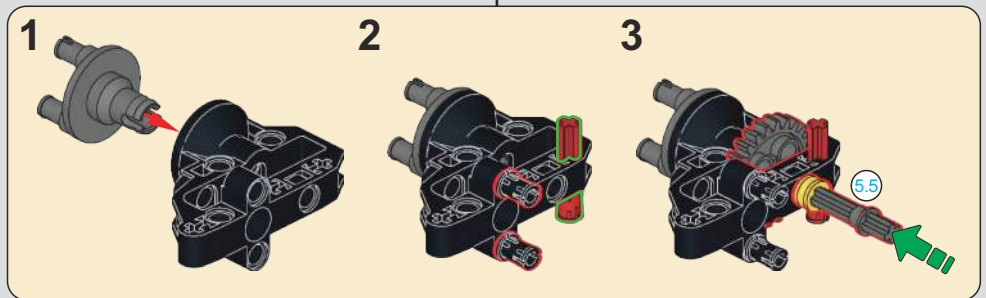
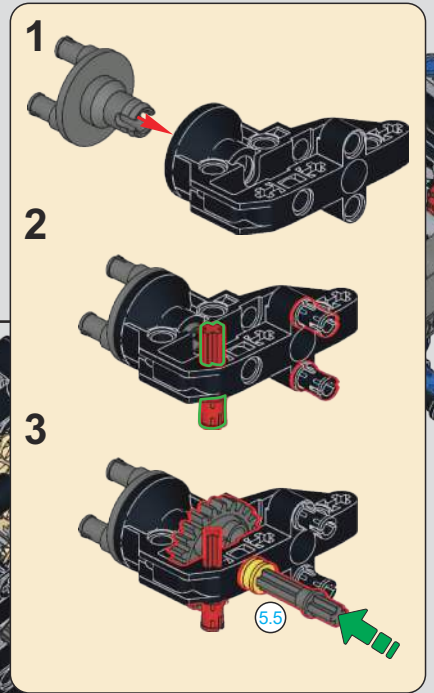
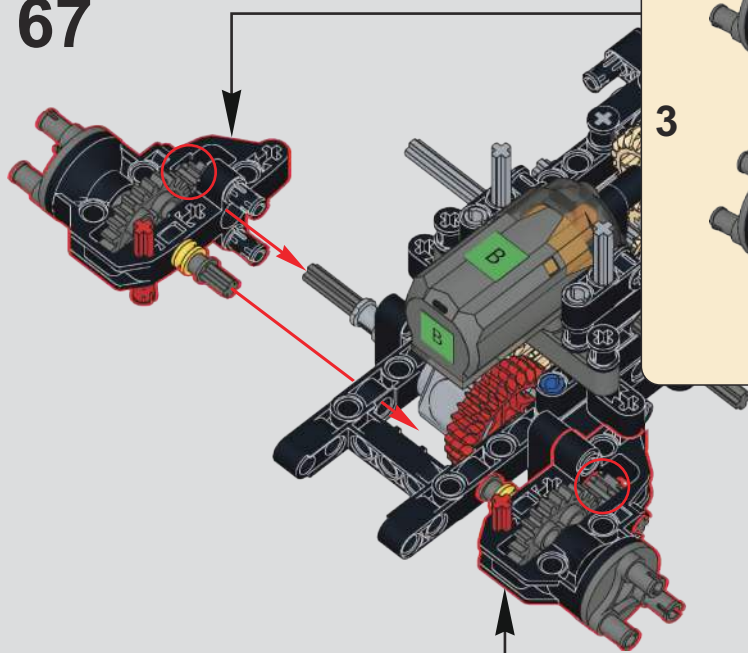

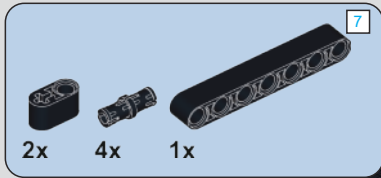

68

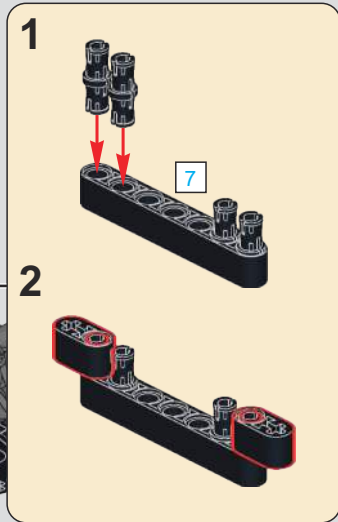
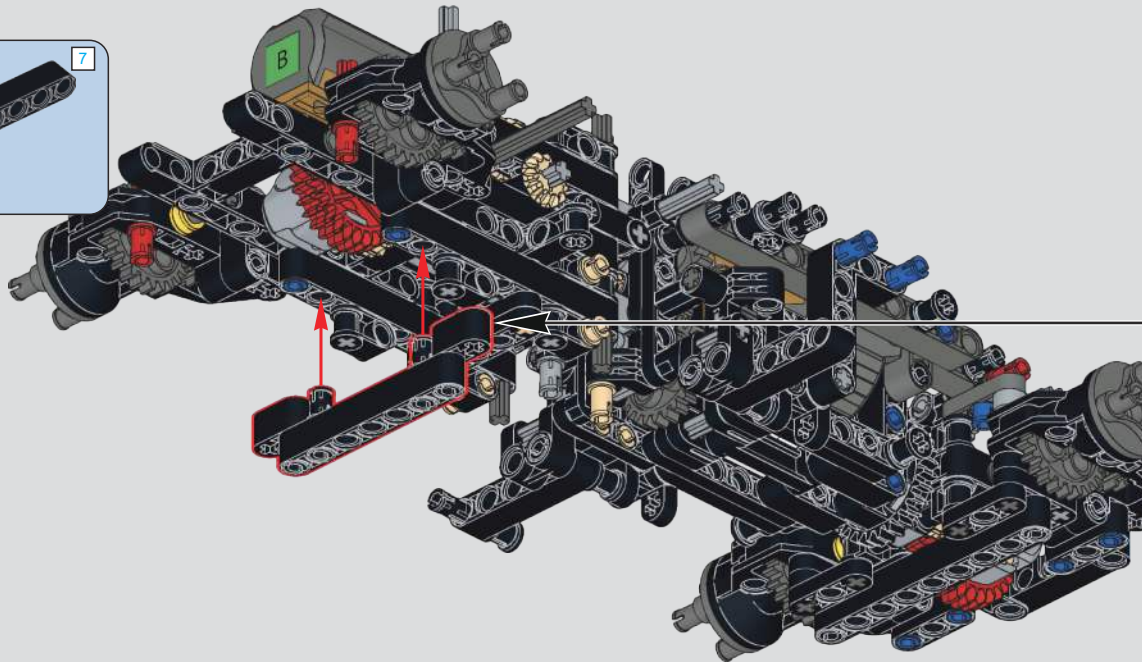

69

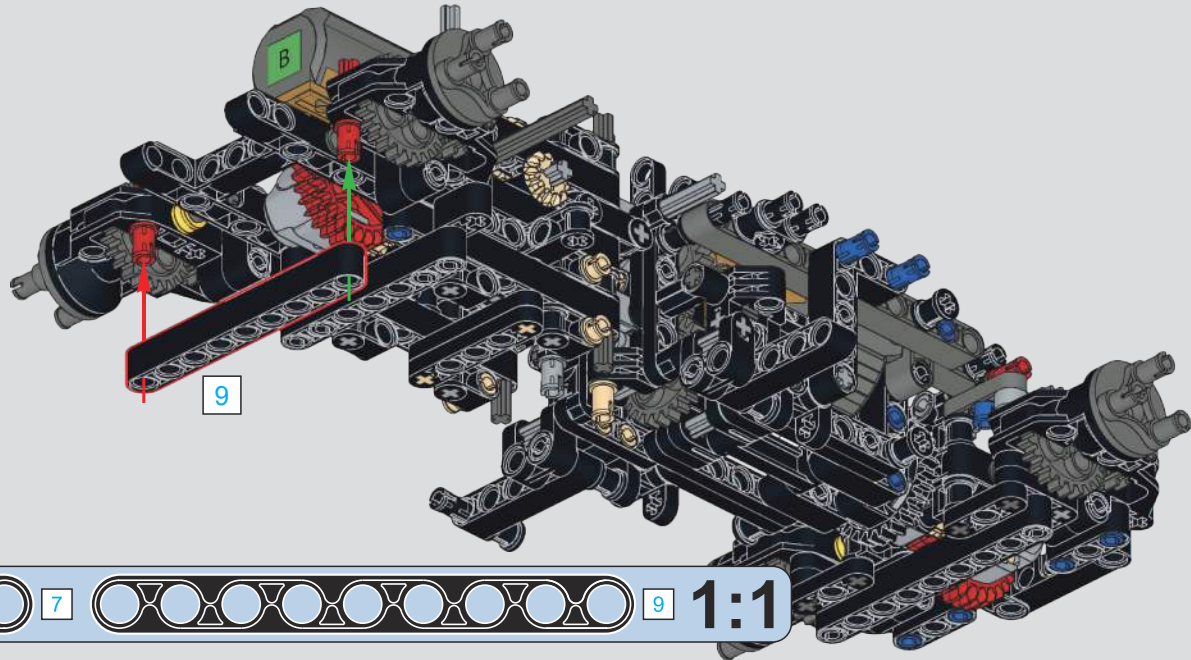

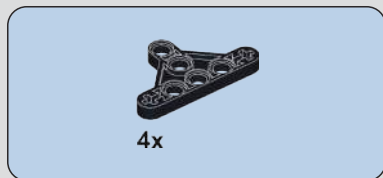
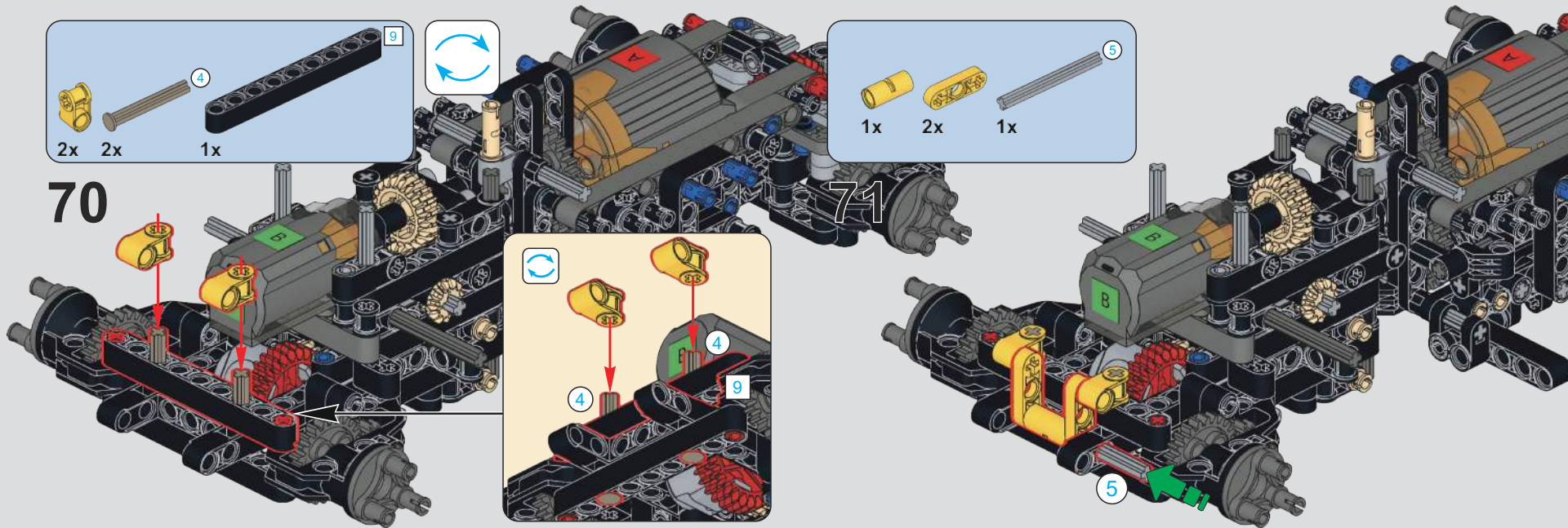

72

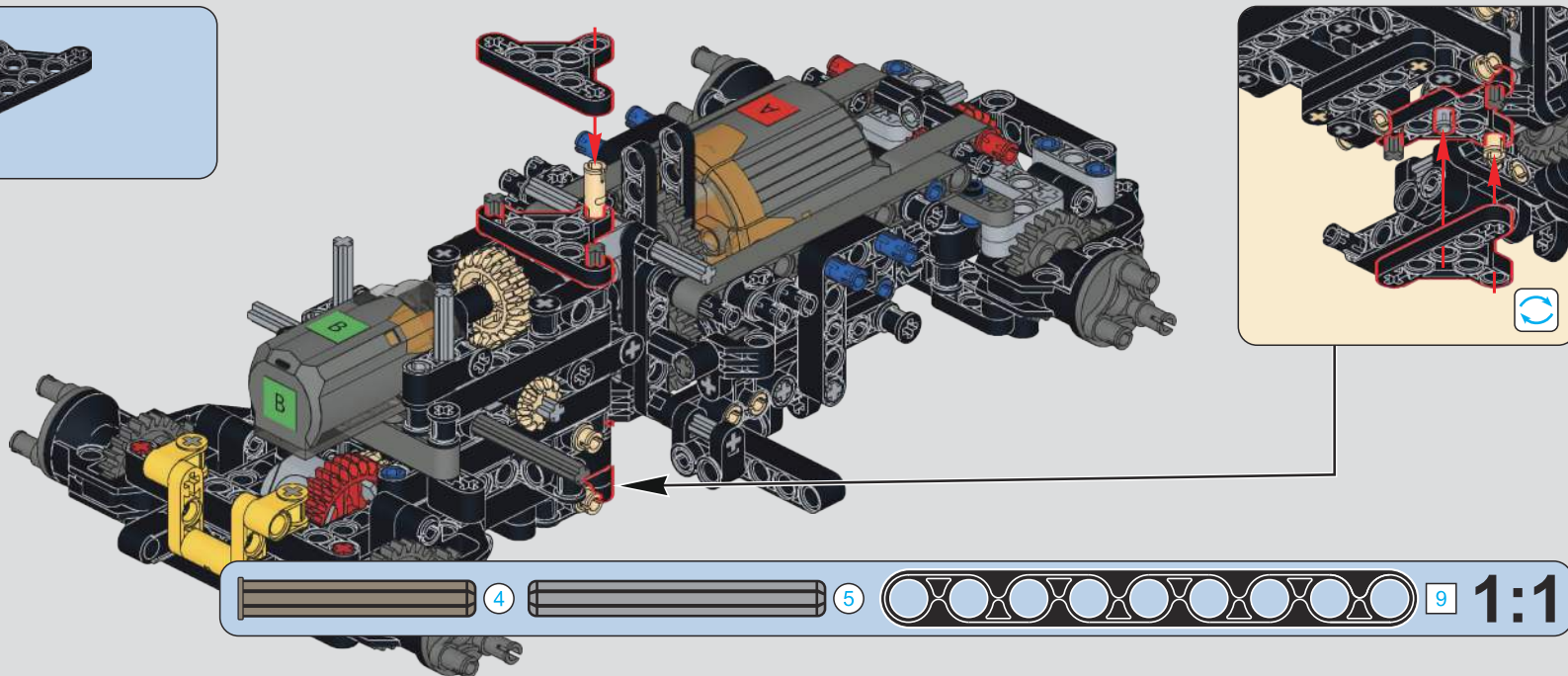

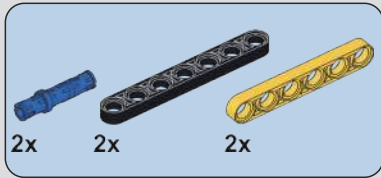

73

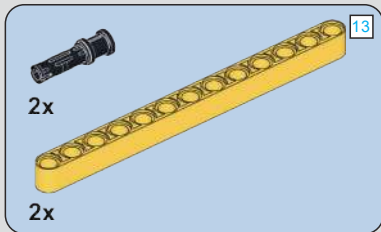
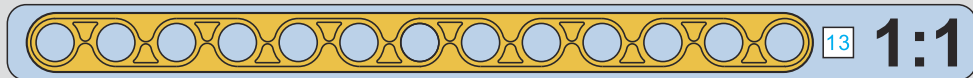
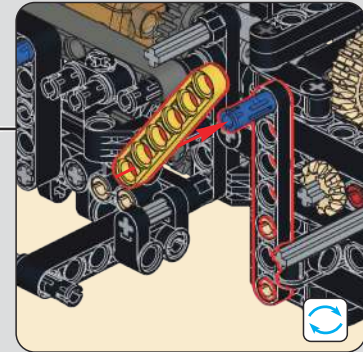
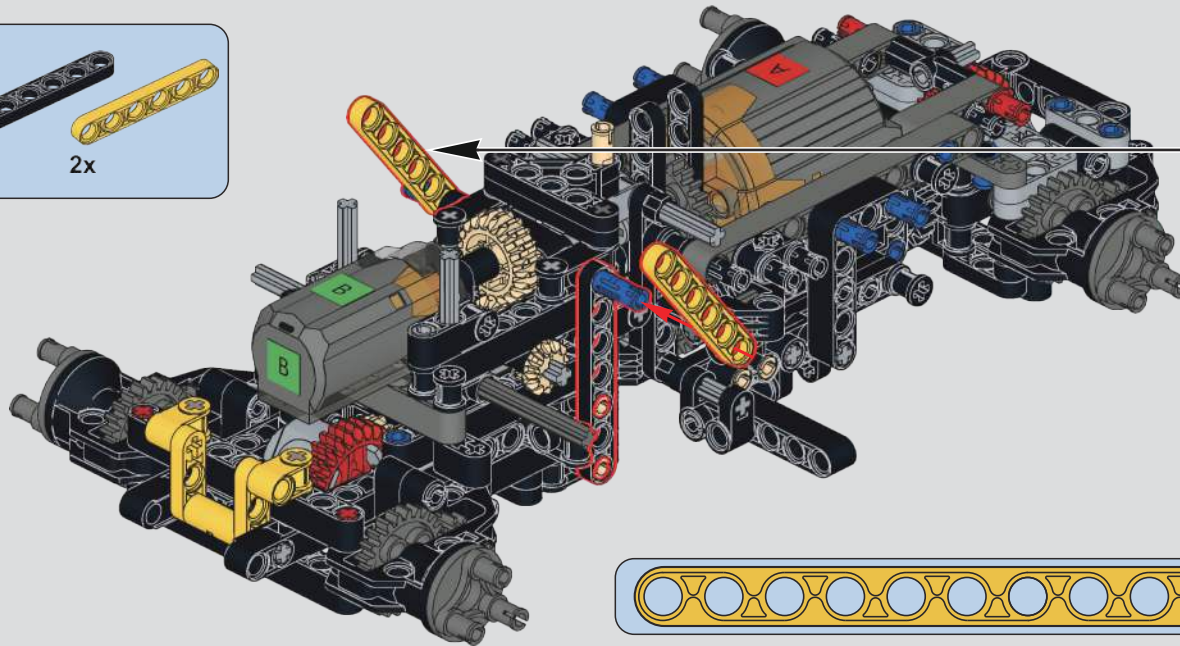

74

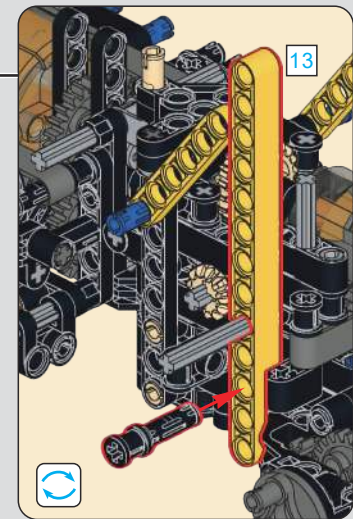
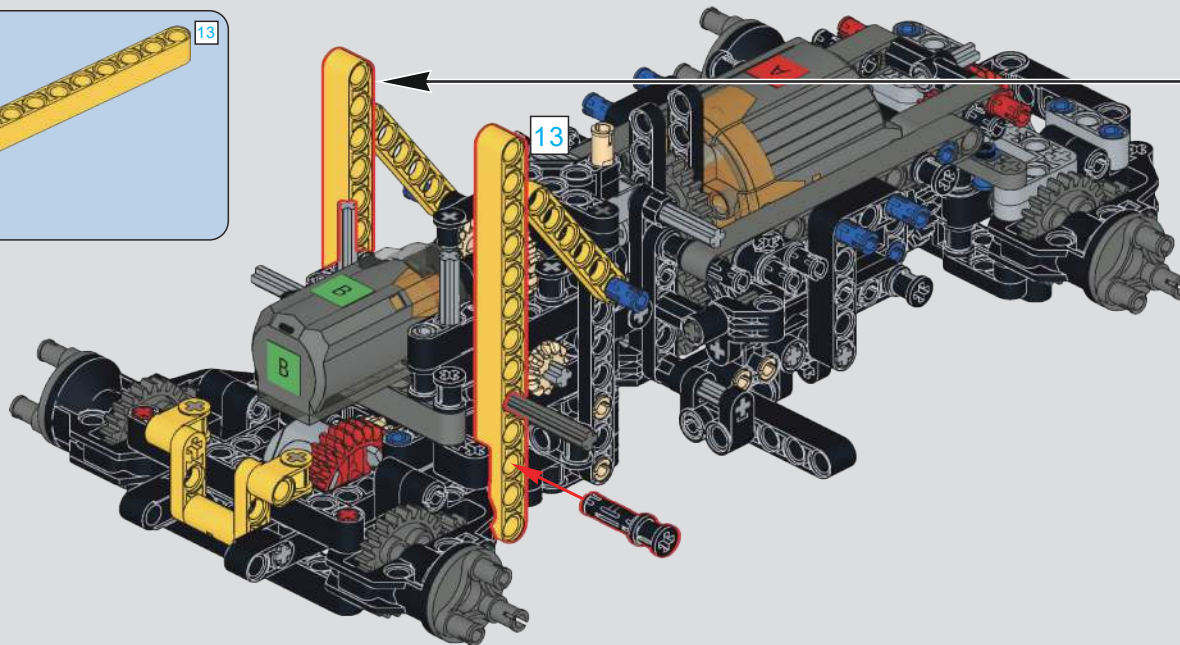

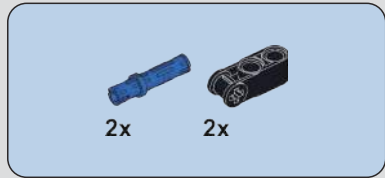

75

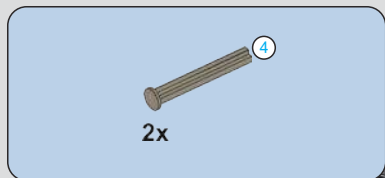
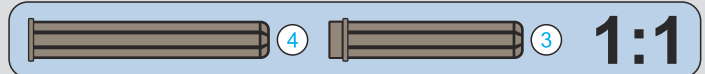
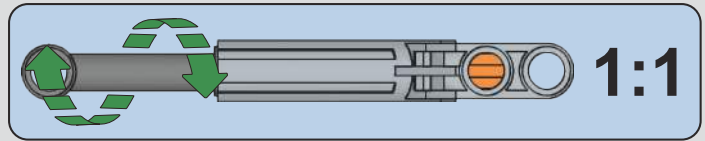
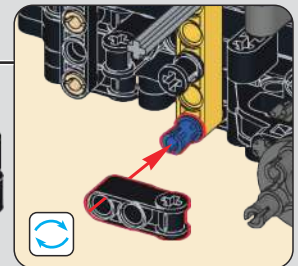
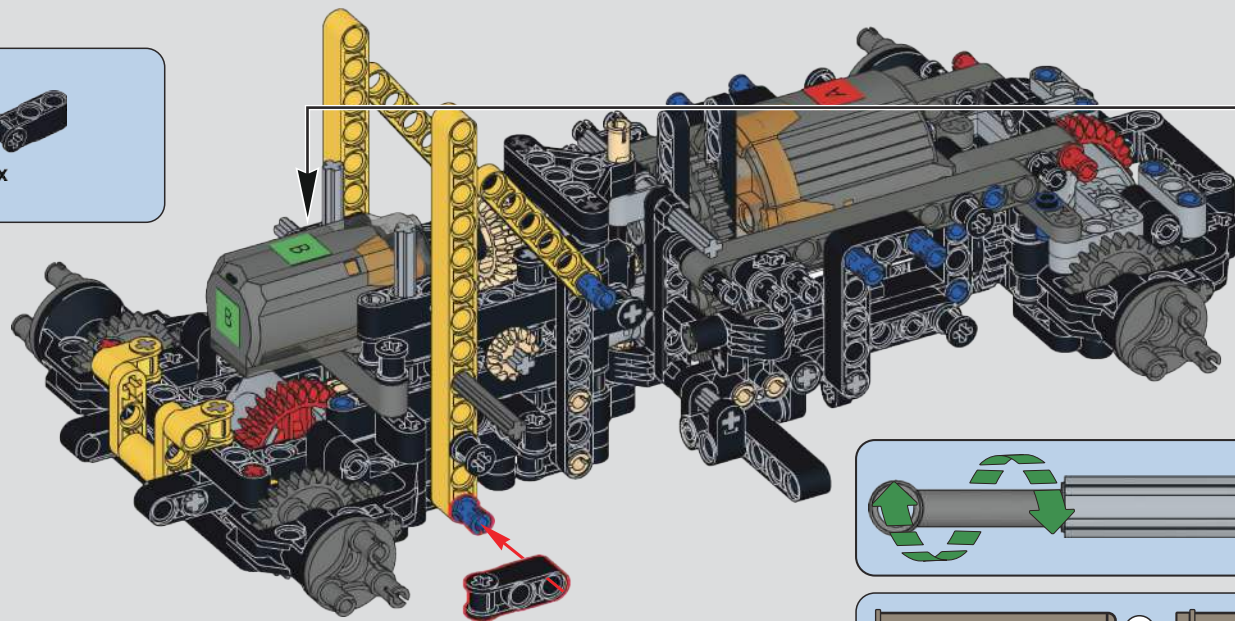

76

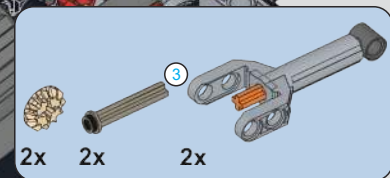
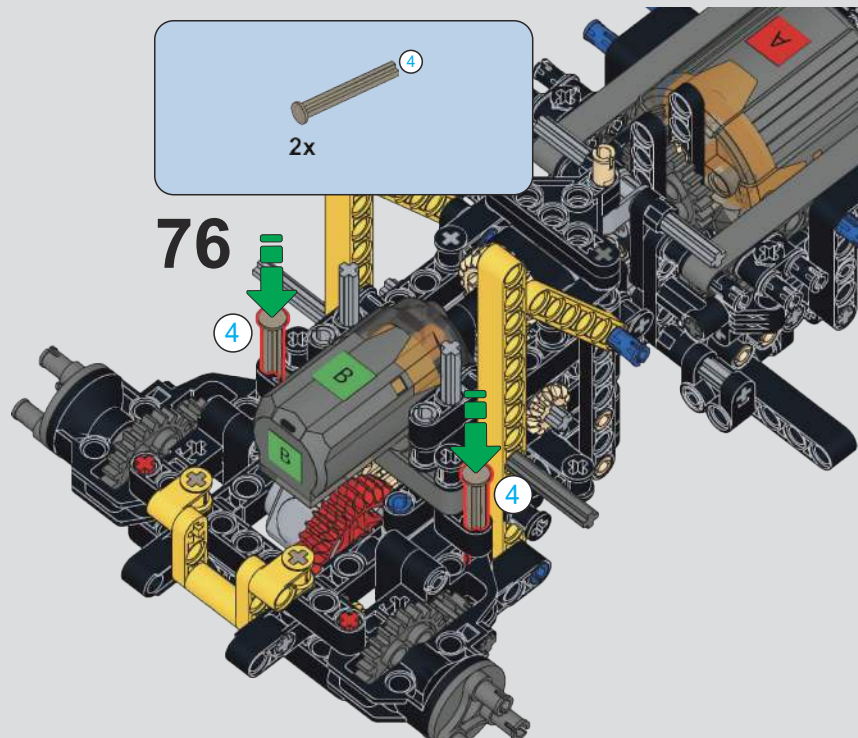

77

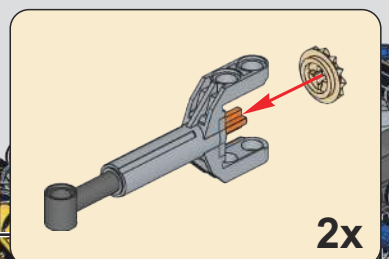
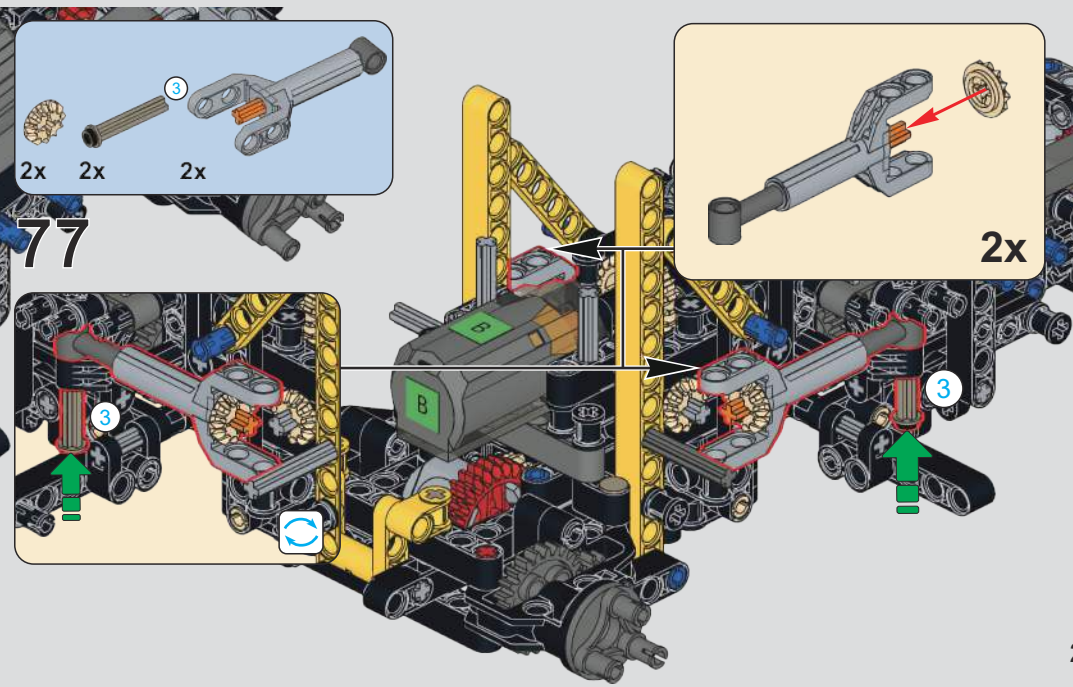

(光滑栓)(Technic Pin without Friction)

2x 1x 2x

1x 1x

3 13

78

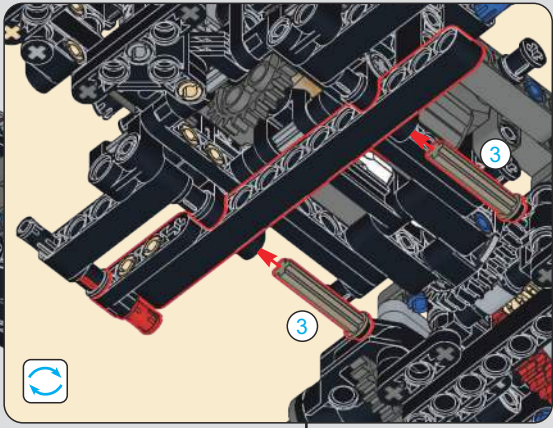
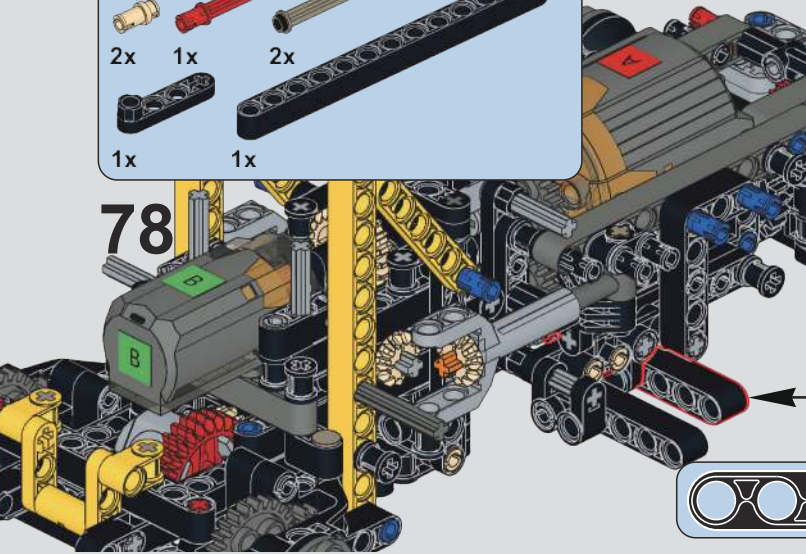

1

2

13 3

13 3 1:1

2x 2x

79

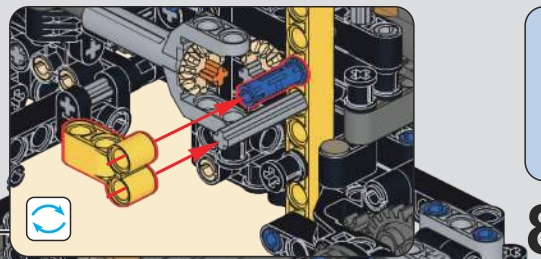
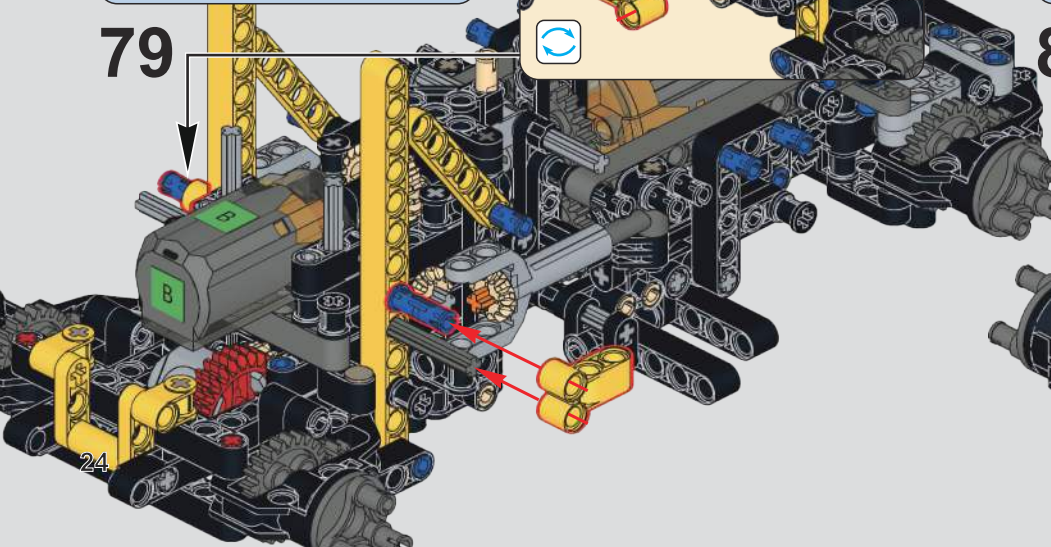

2x

80

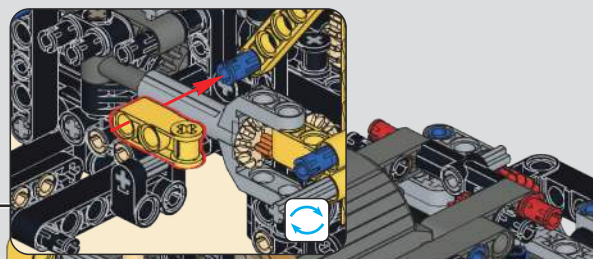
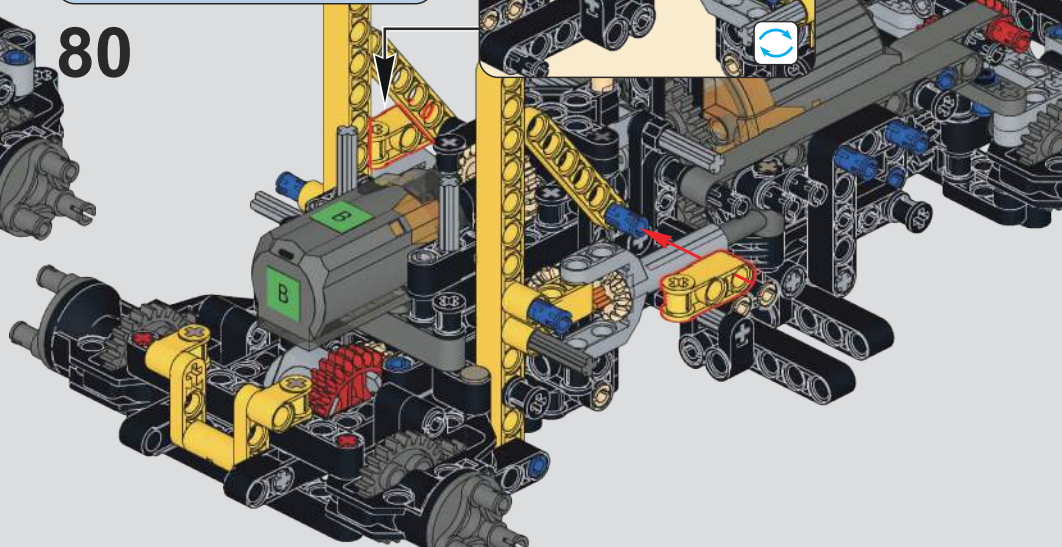

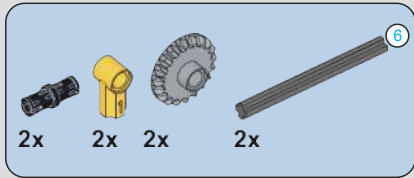

81

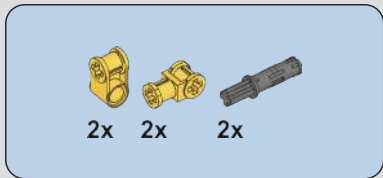
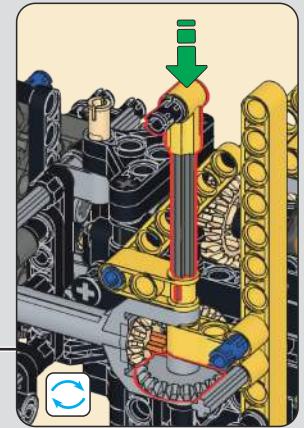
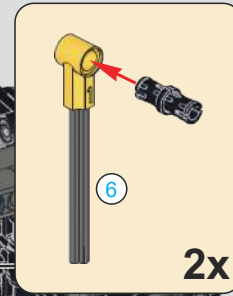
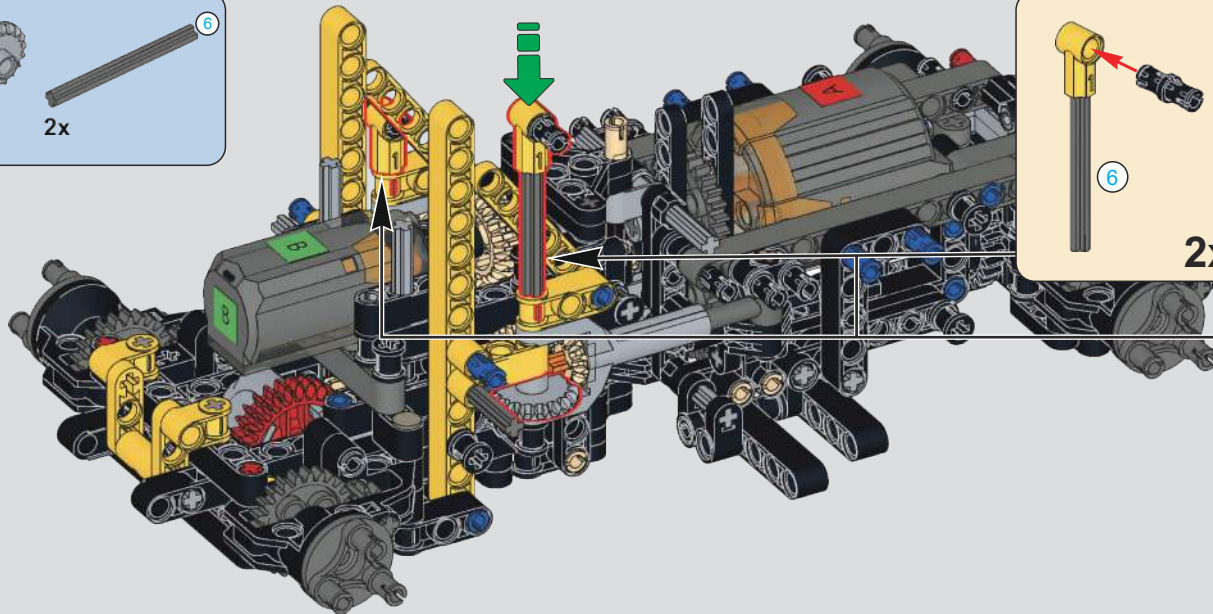

82

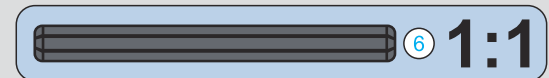
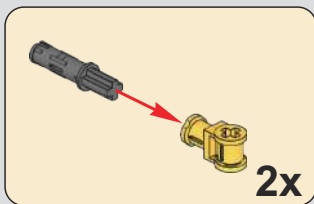
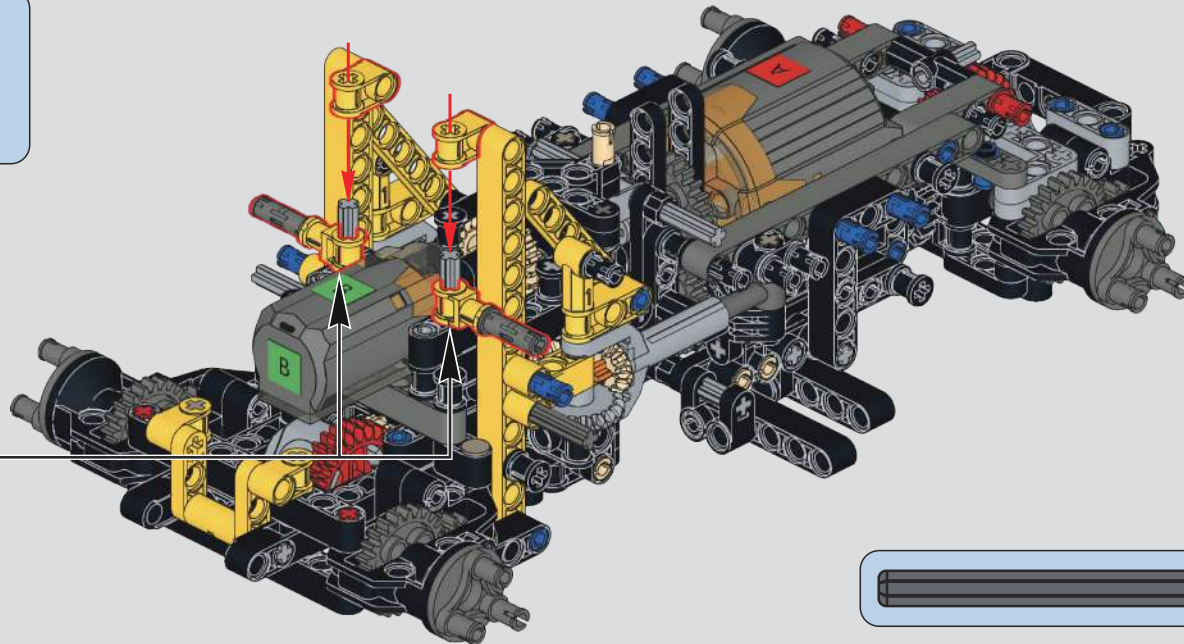

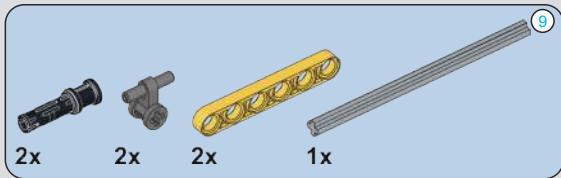
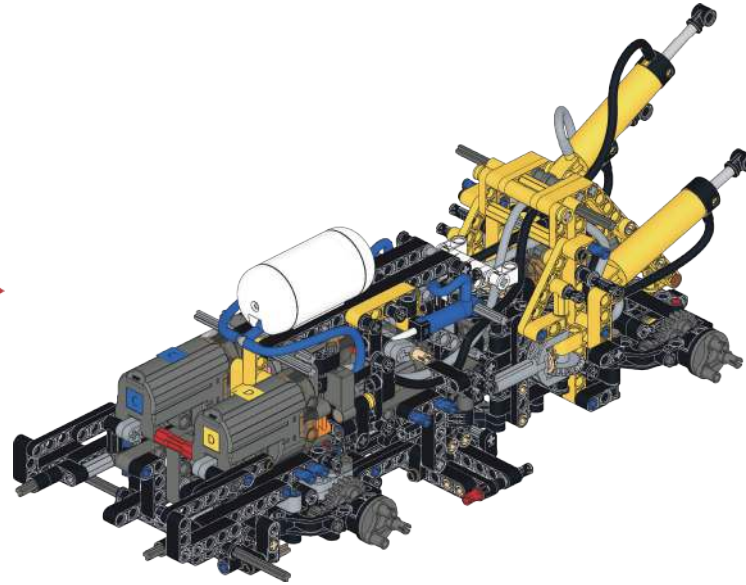

83

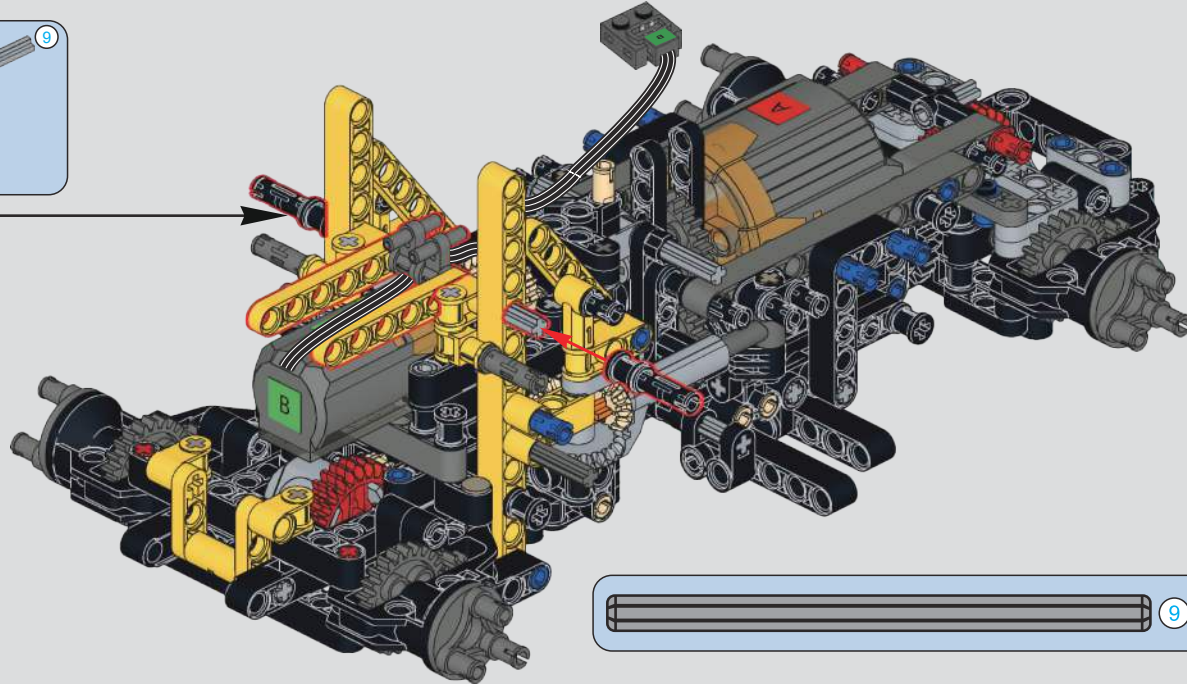
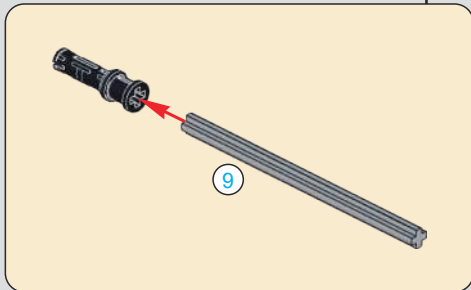

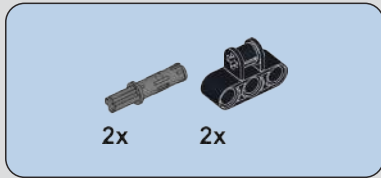

84

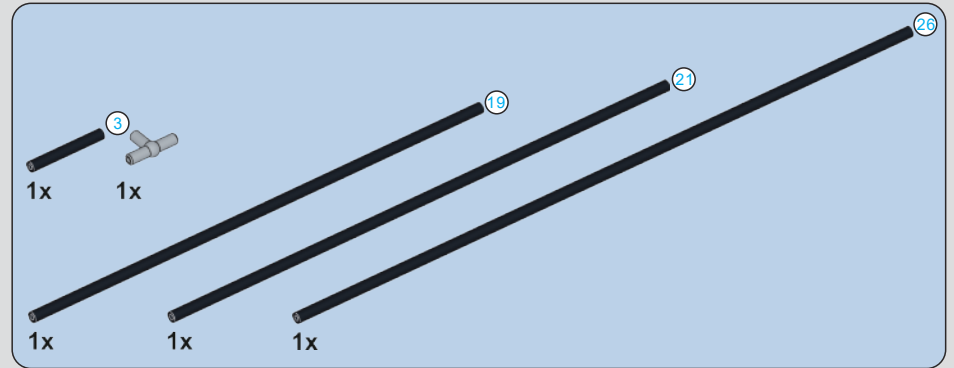
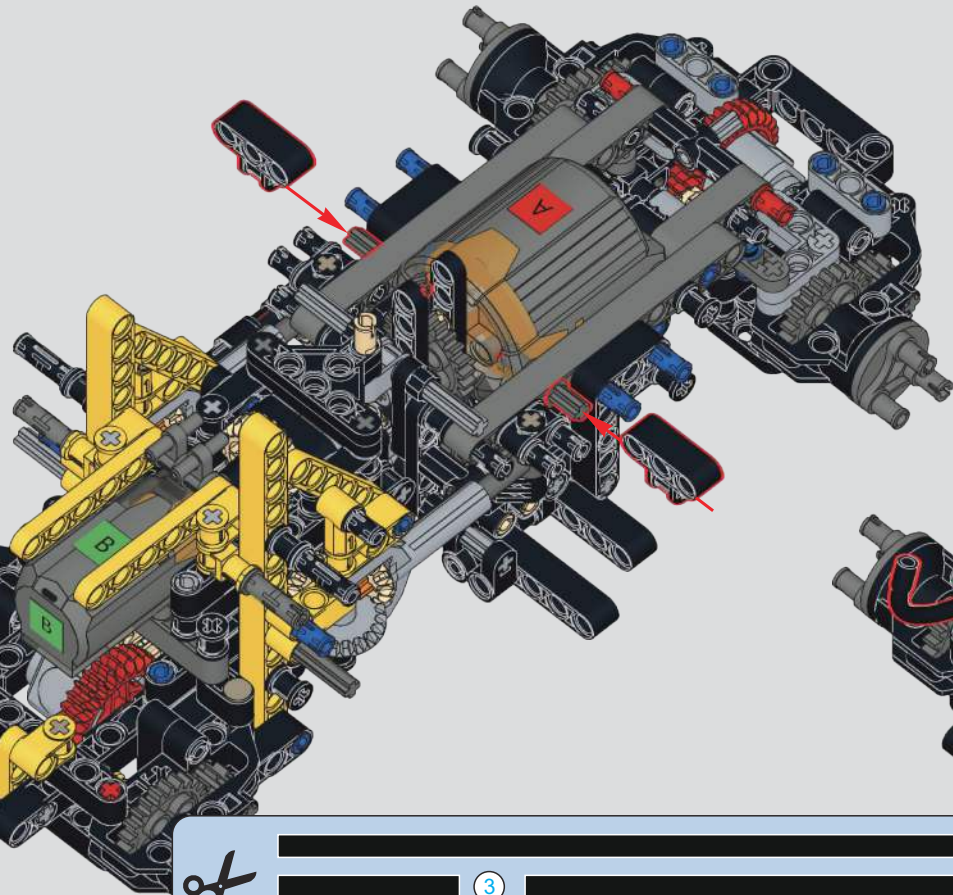

85

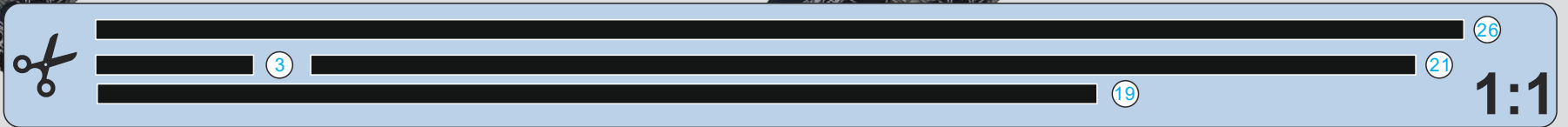
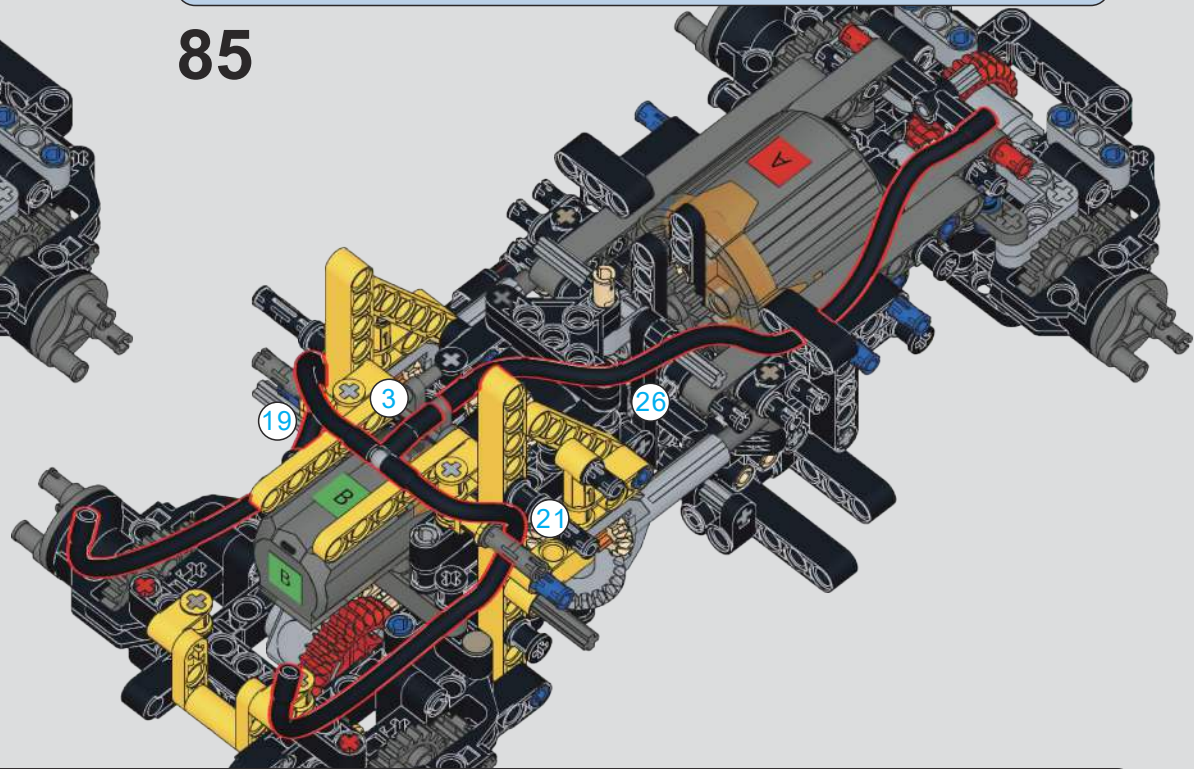

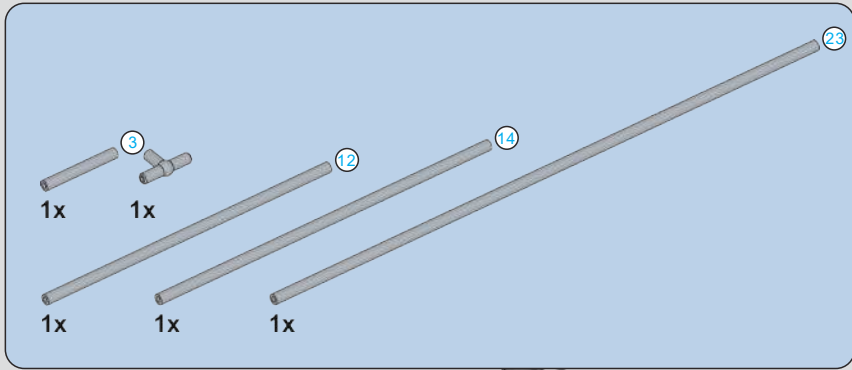

86

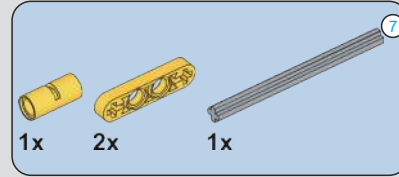
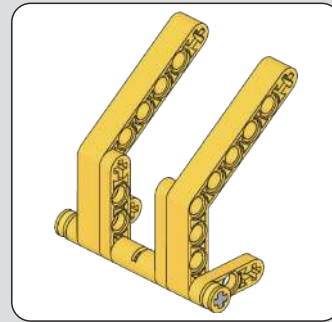
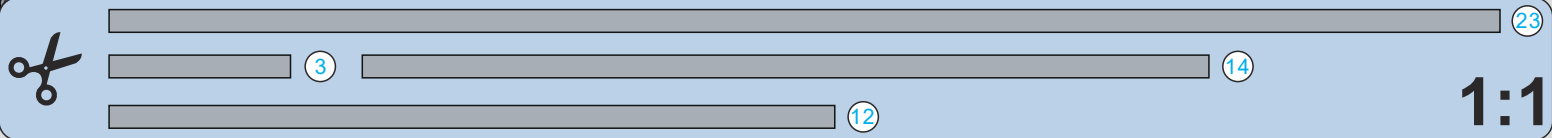
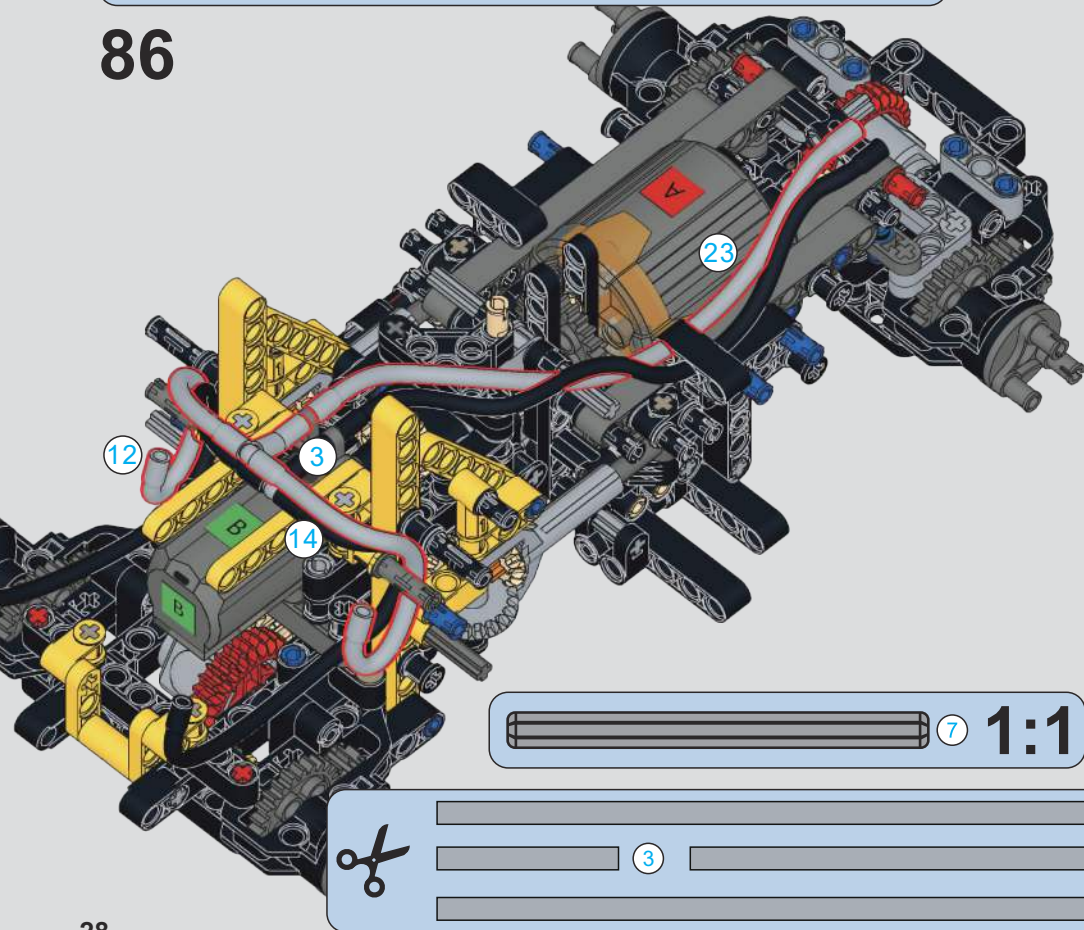

87

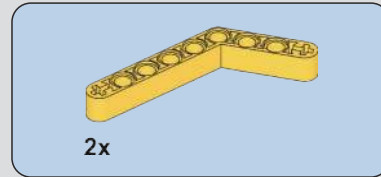
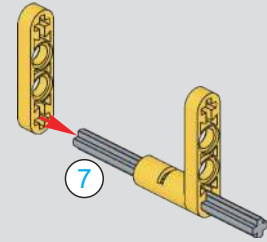

88

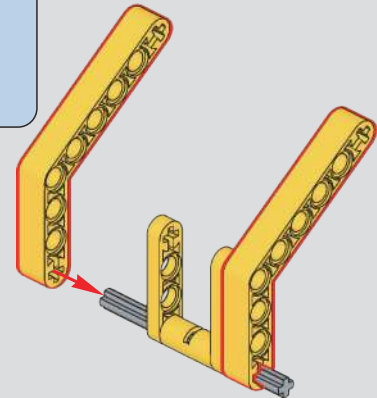

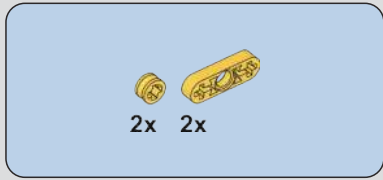

89

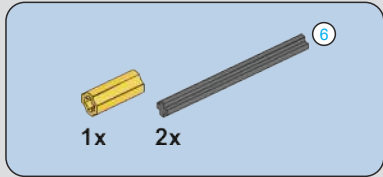
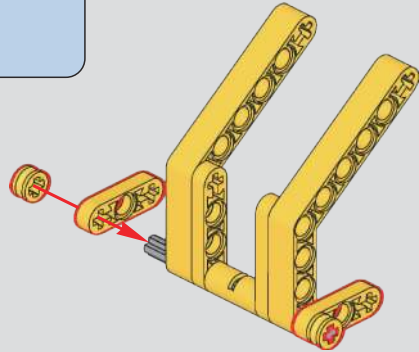

90

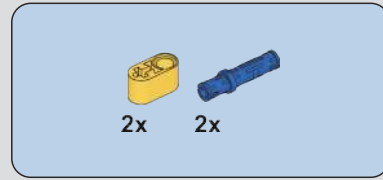
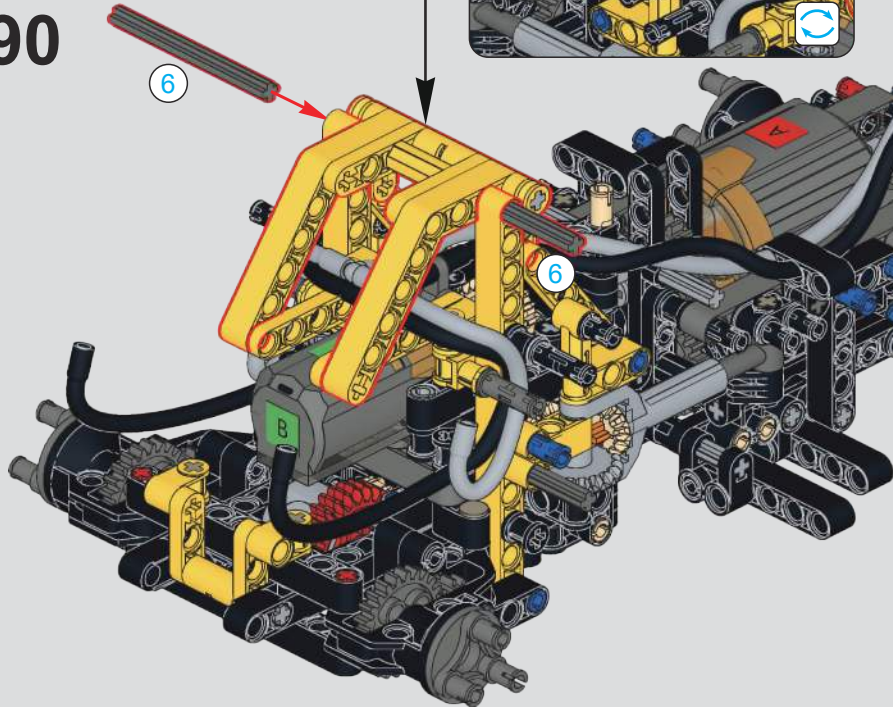

91

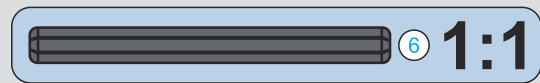
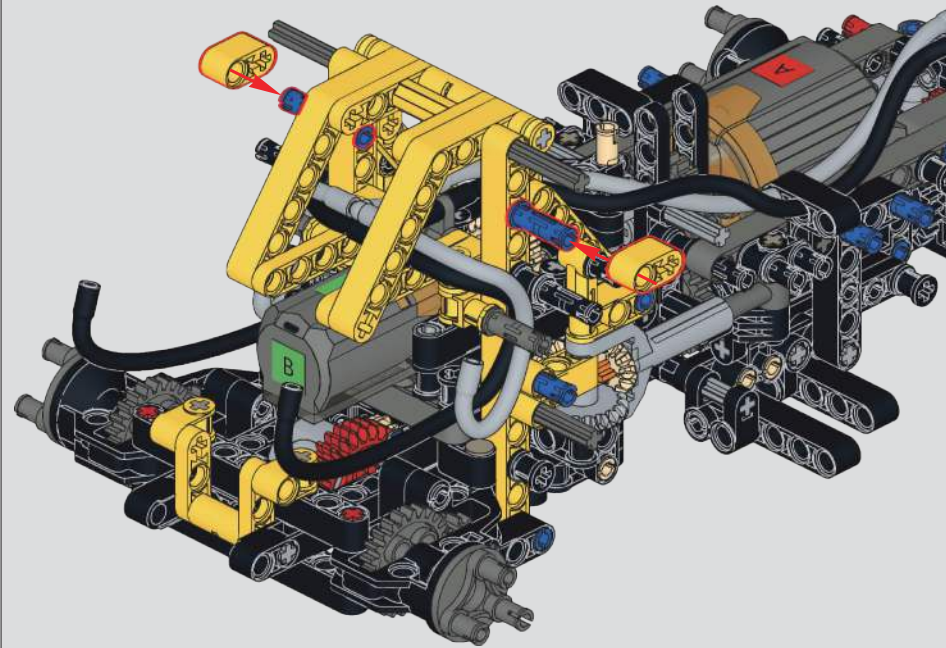

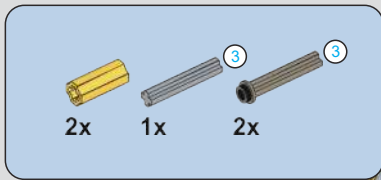

92

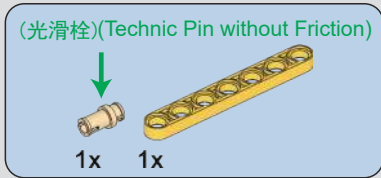
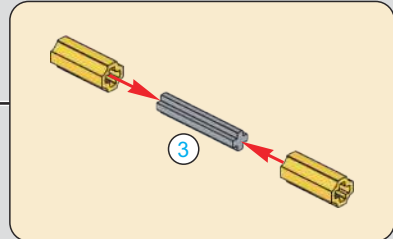
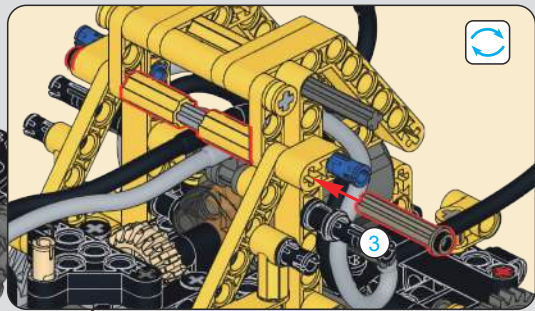
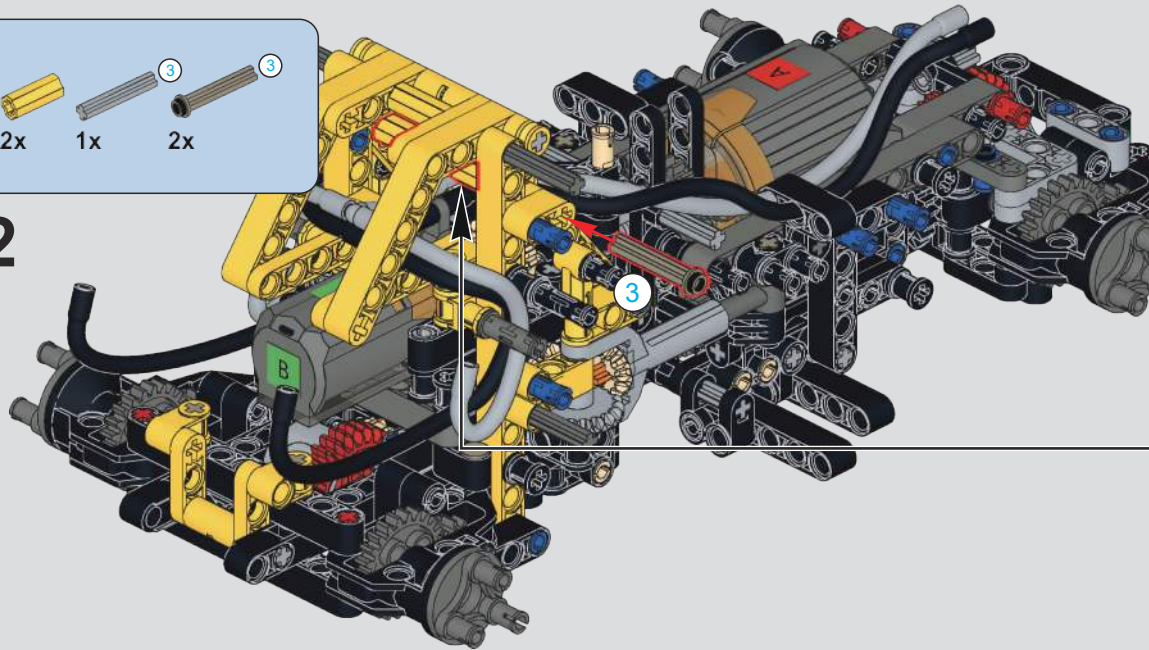

93

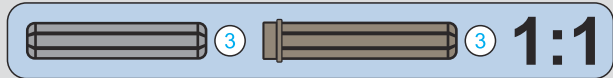
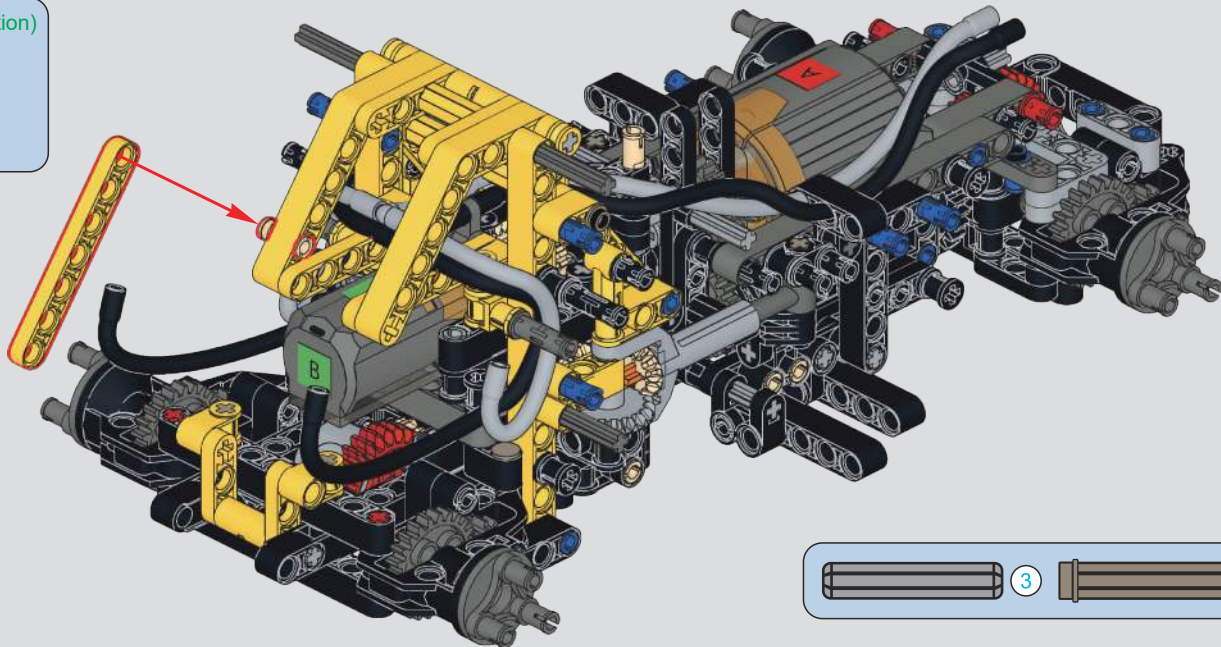

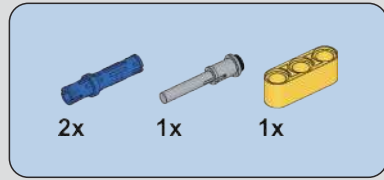
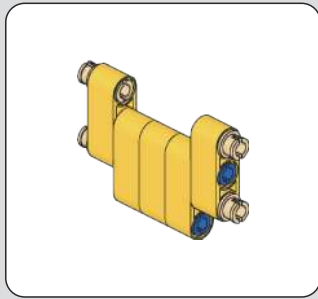

94

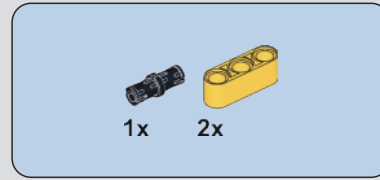
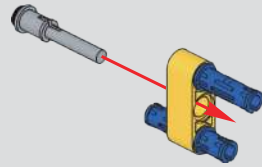

95

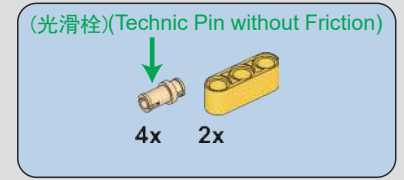
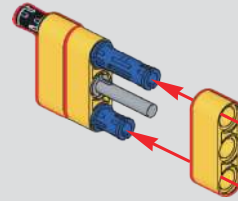

96

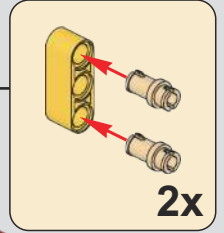
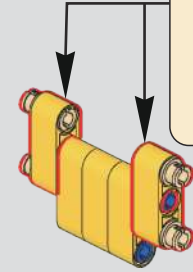

2x

97

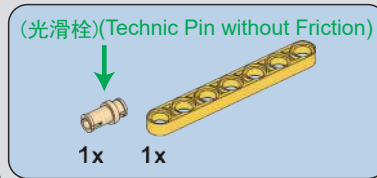
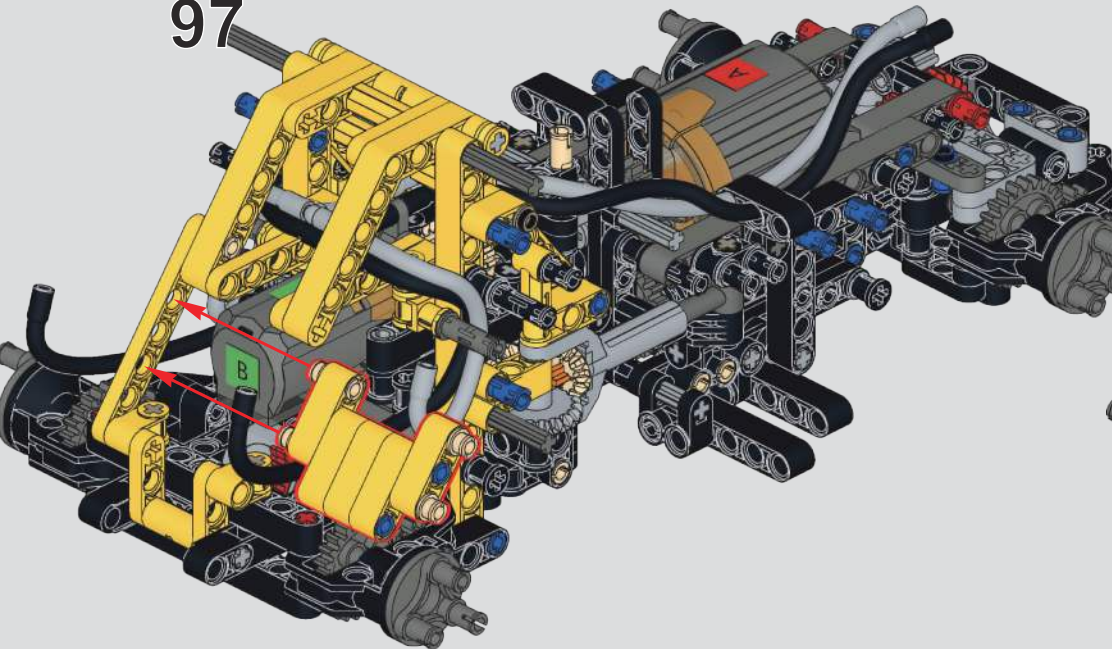

98

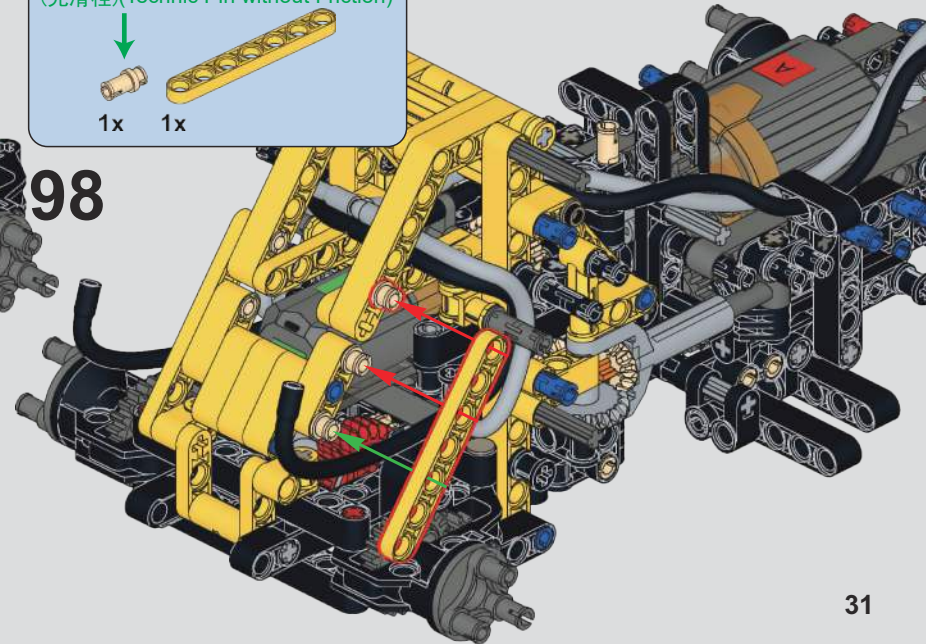

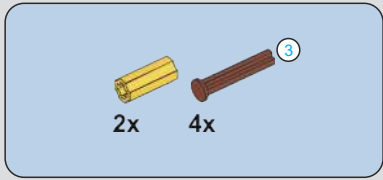

99

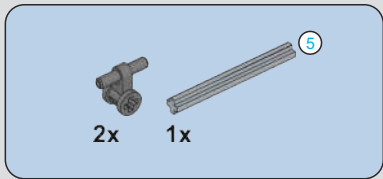
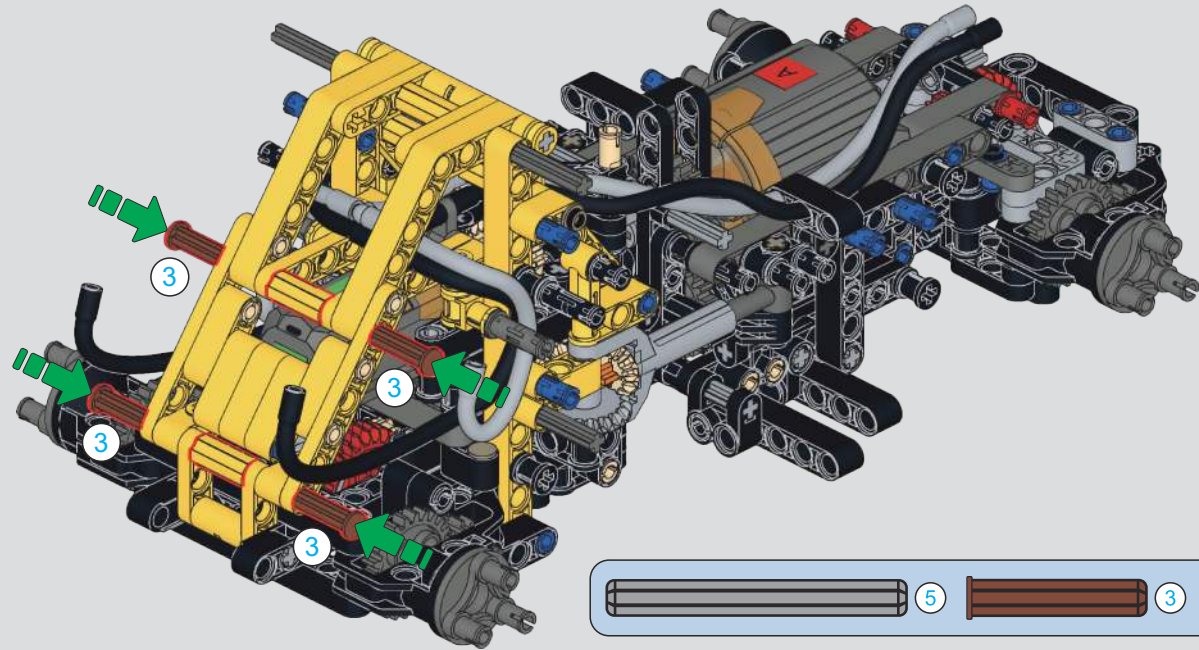

100

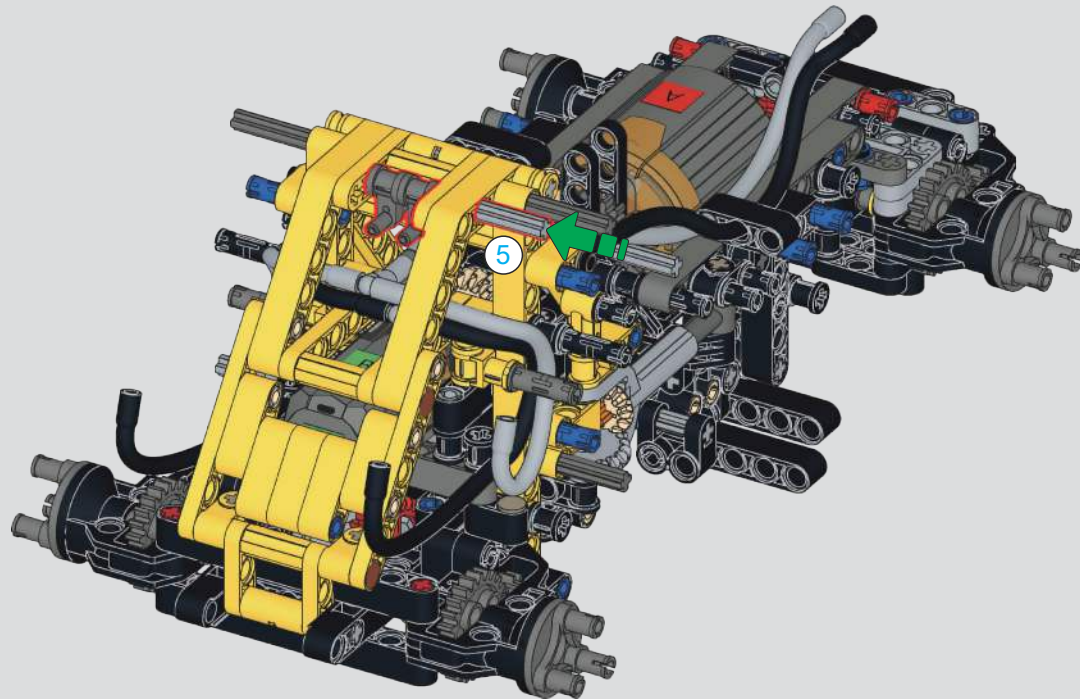

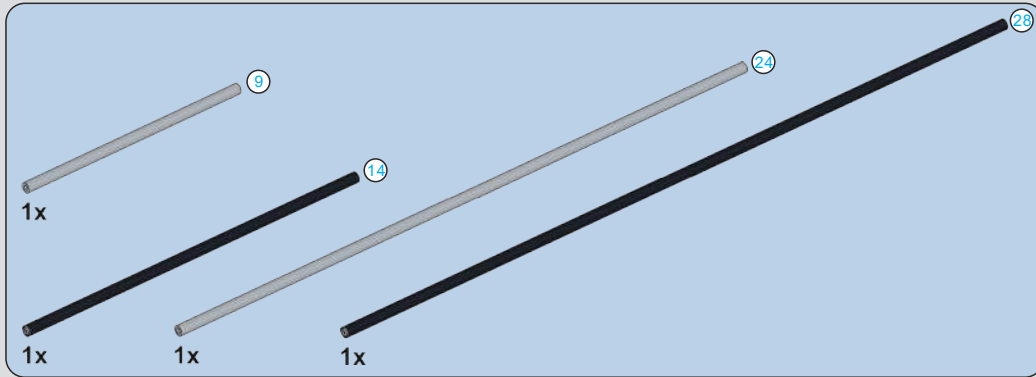

101

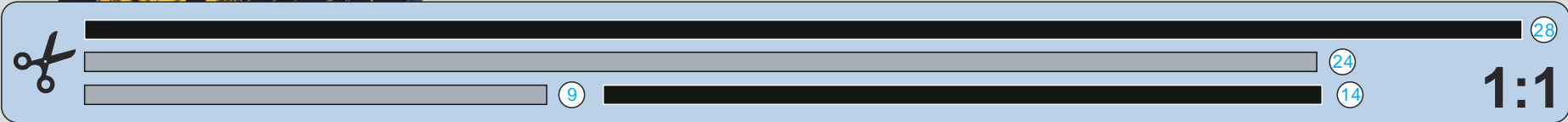
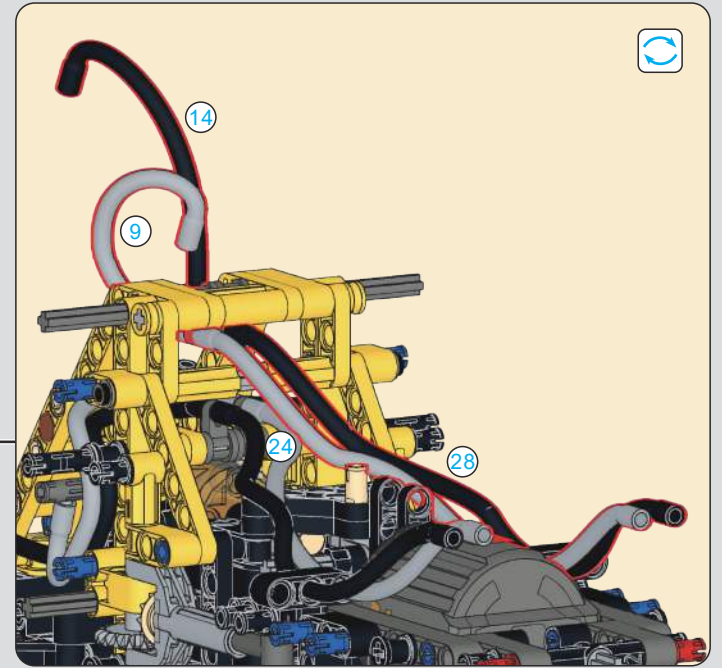
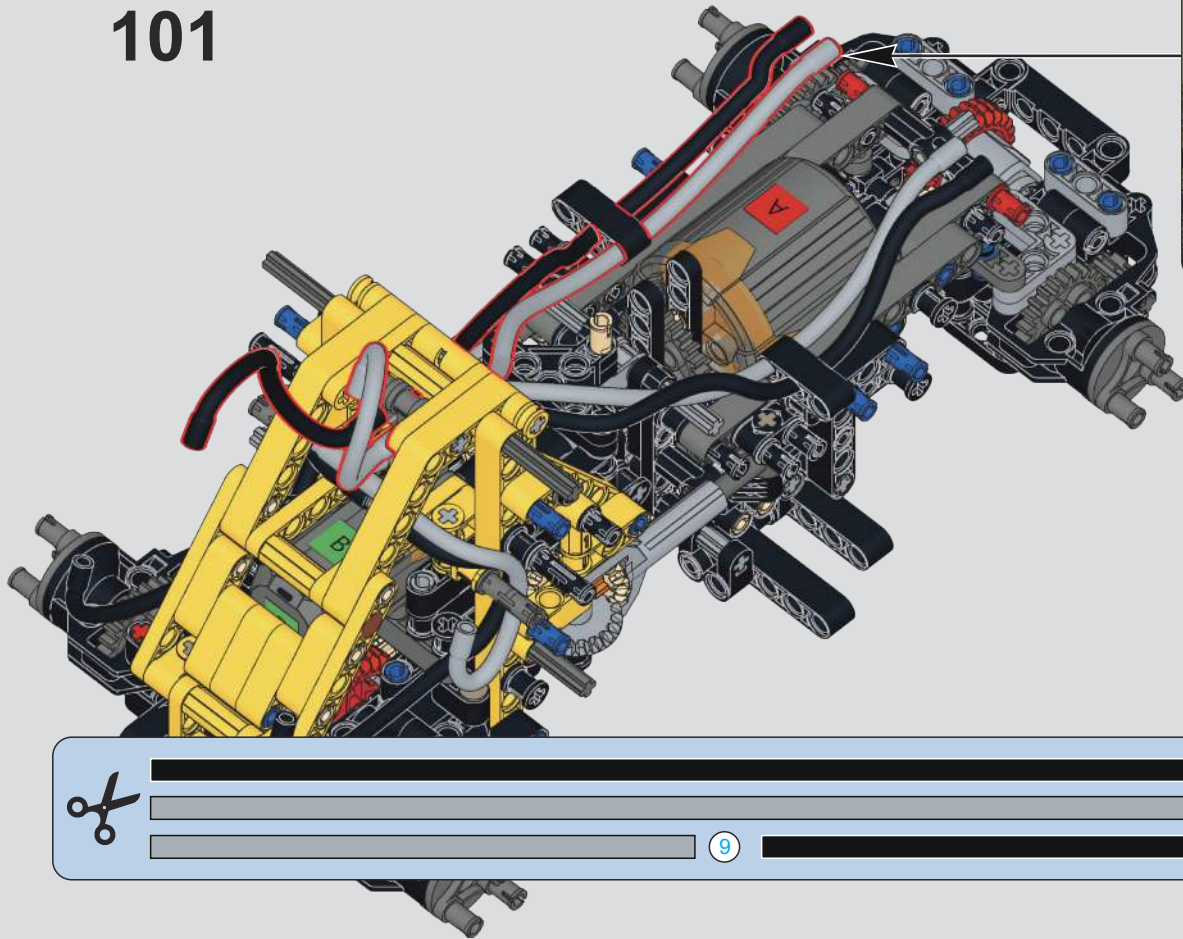

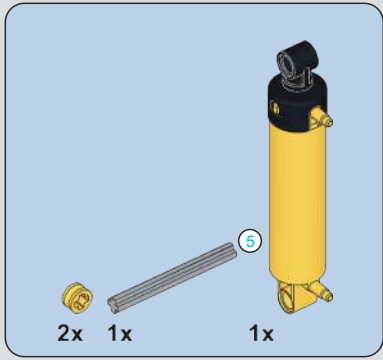

102

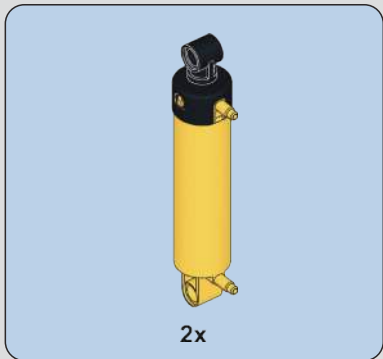
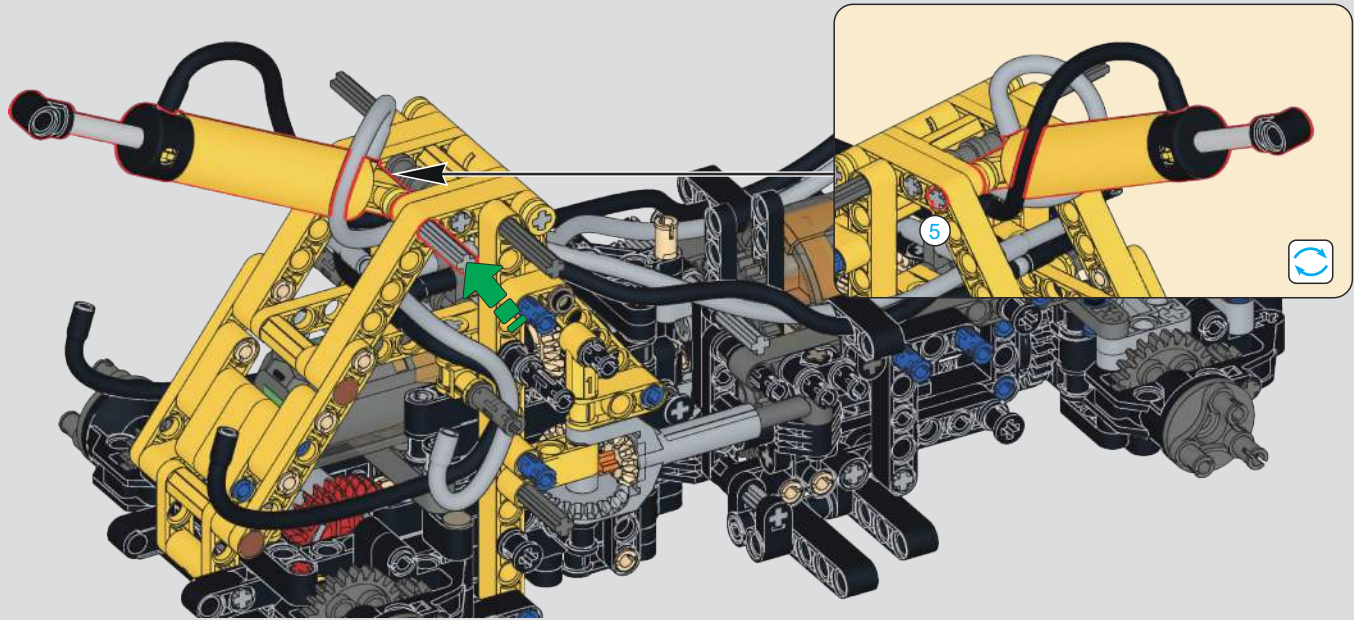

103

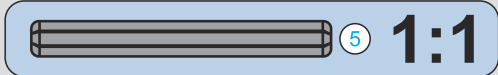
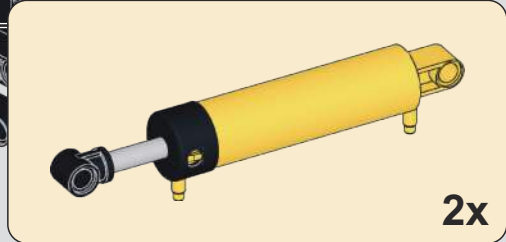
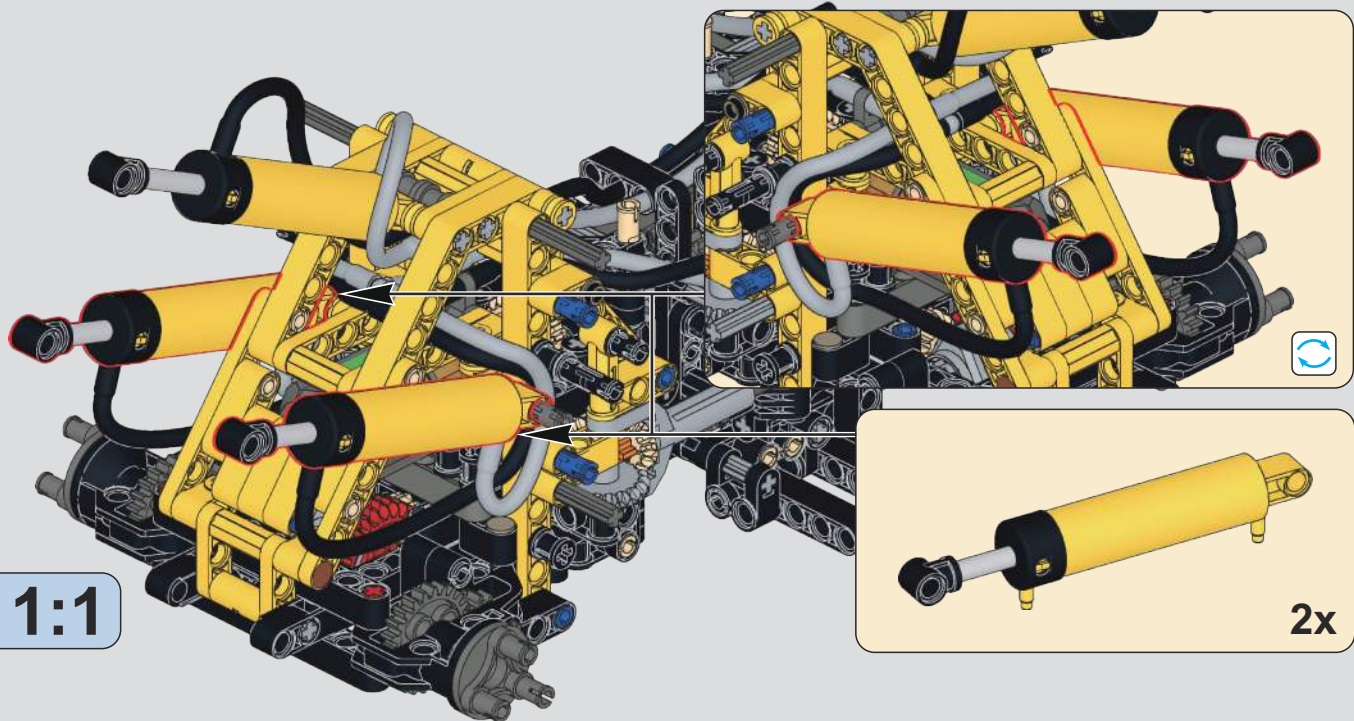

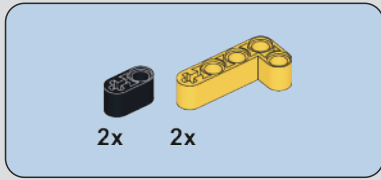

104

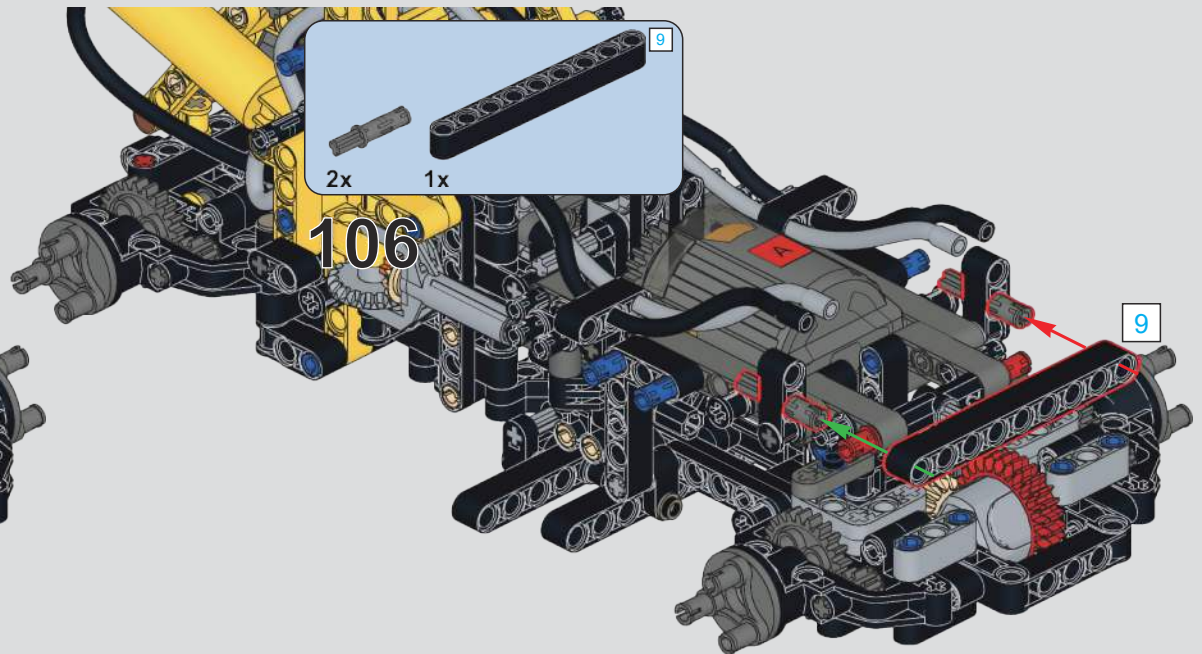
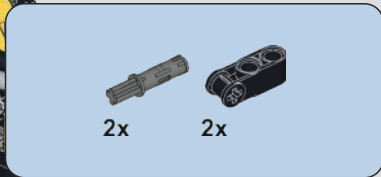
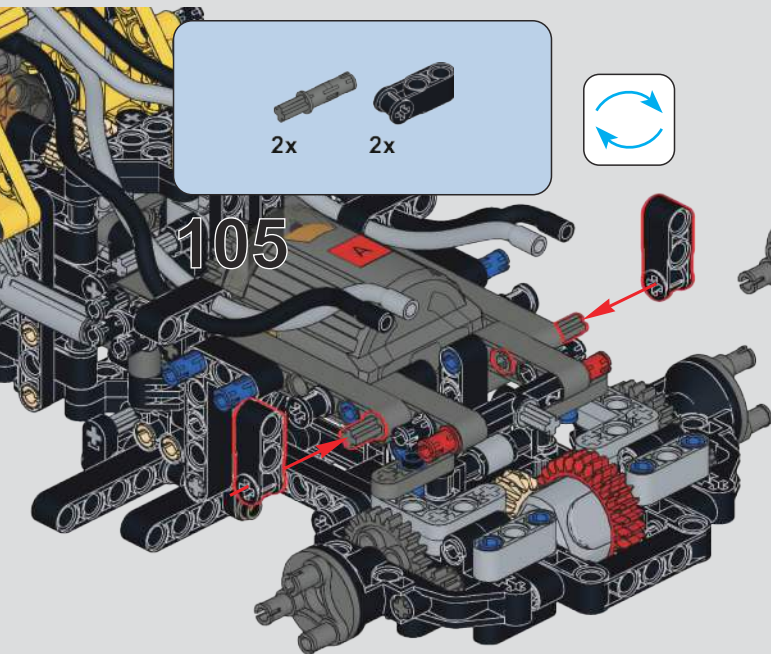
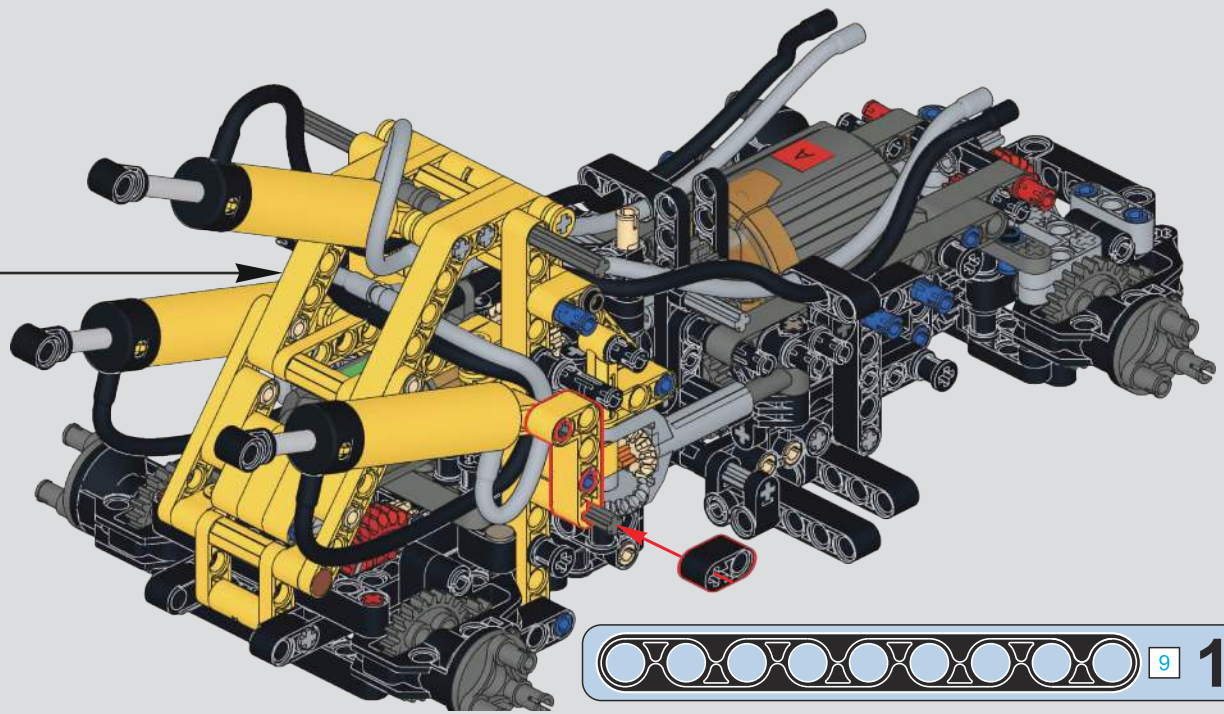
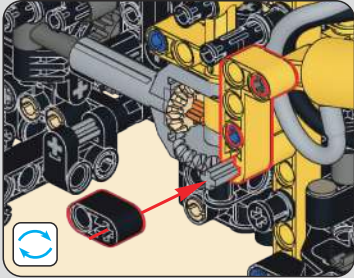

9

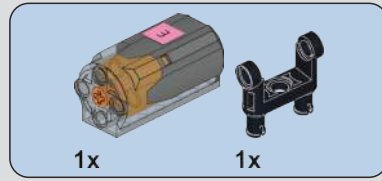
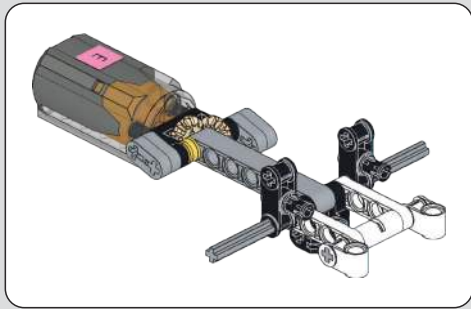

107

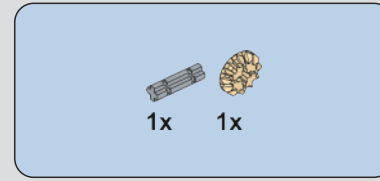
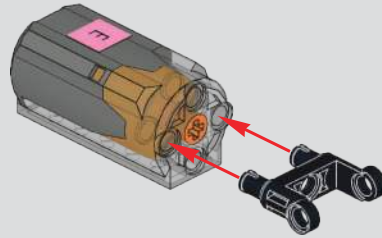

108

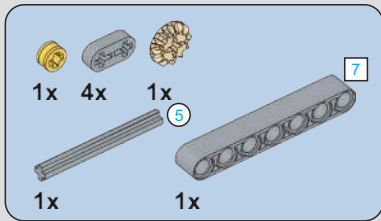
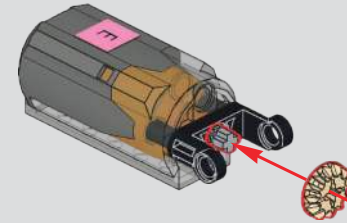

109

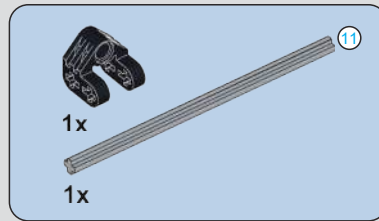
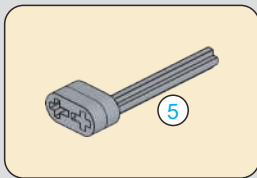
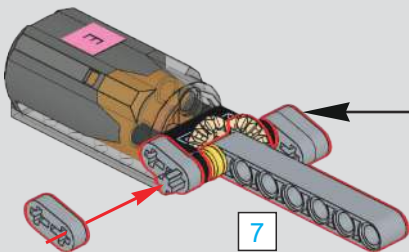

110

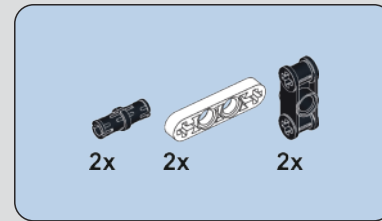
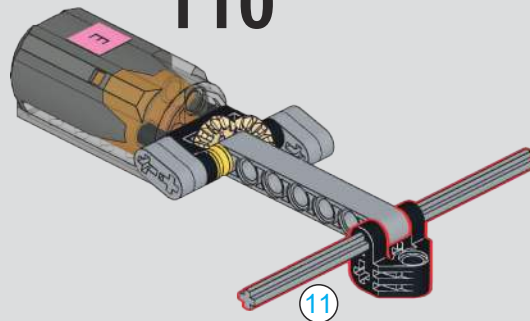

111

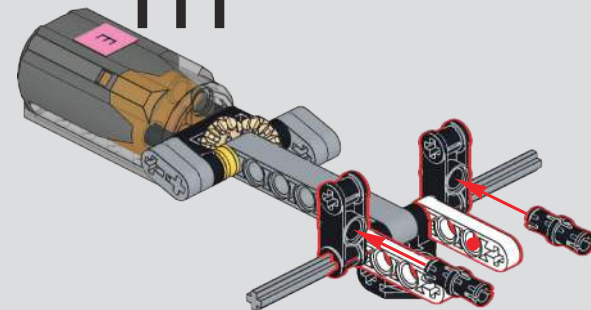

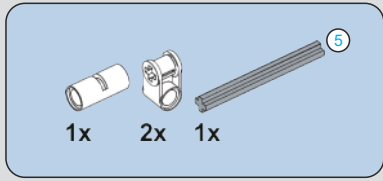

112

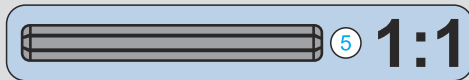
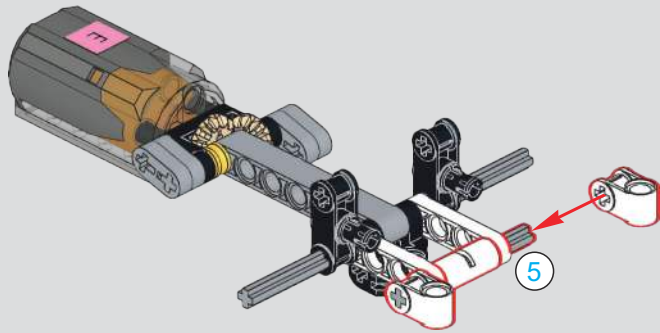

113

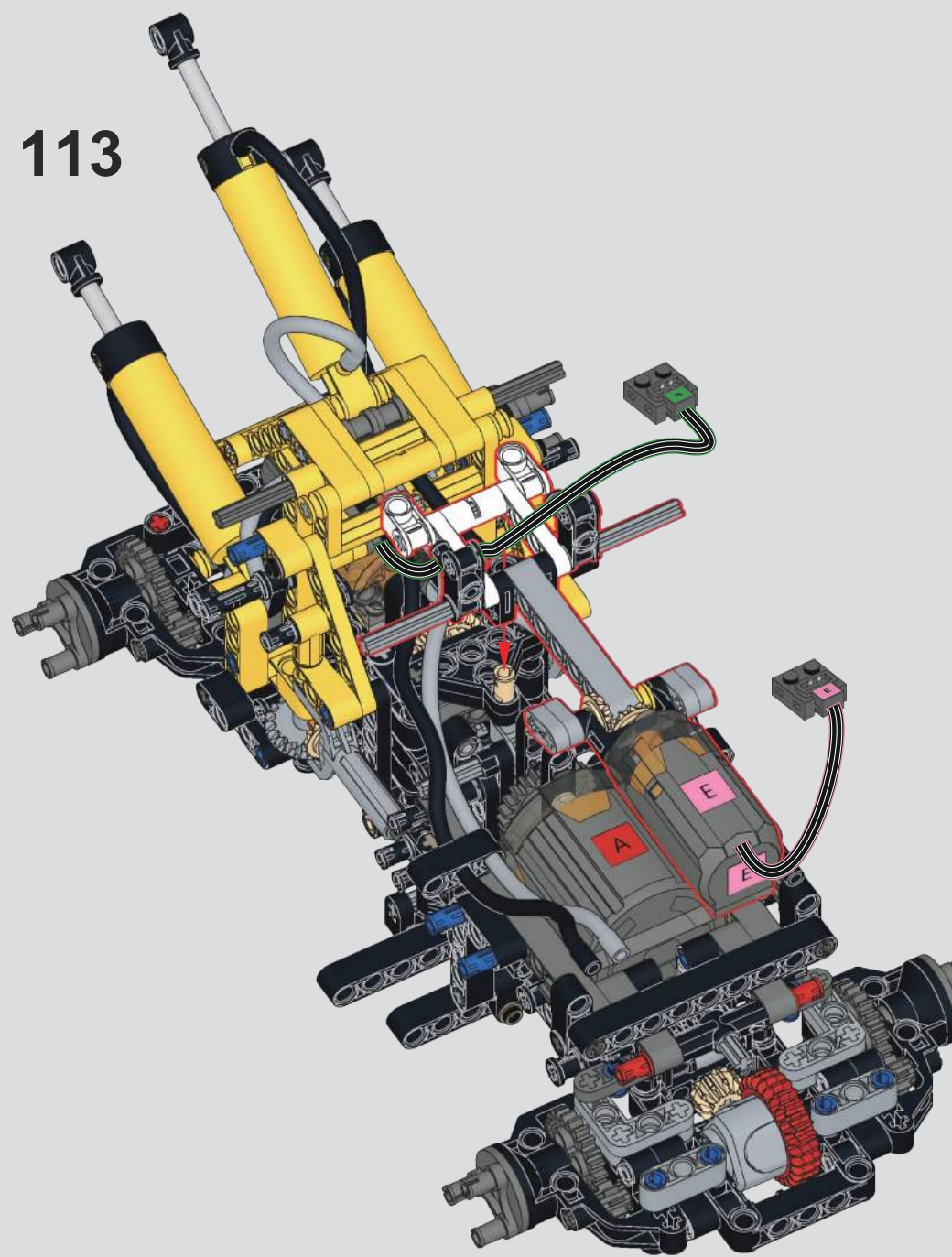

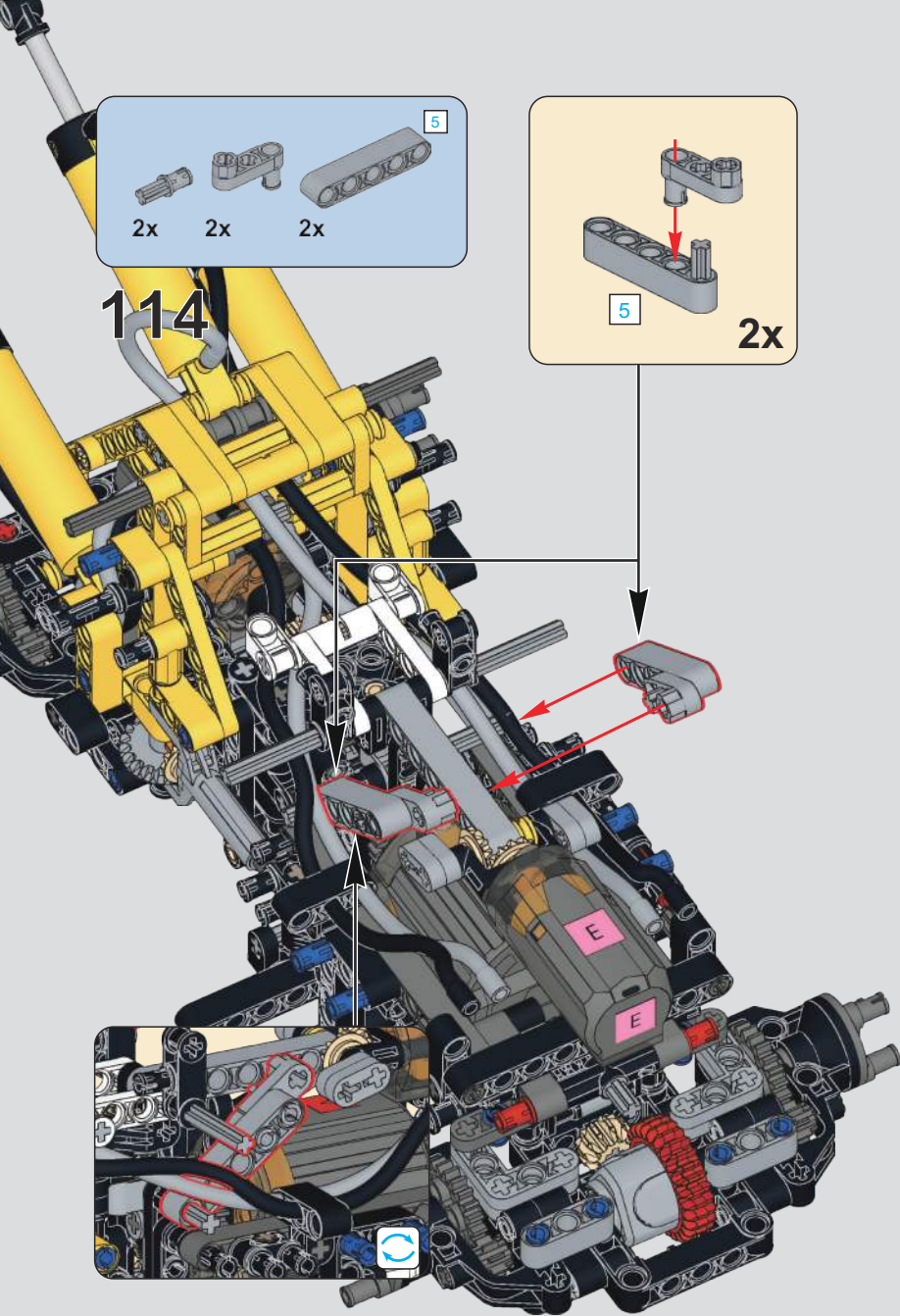

114

2x 2x 2x

5

5

2x

5

1x

115

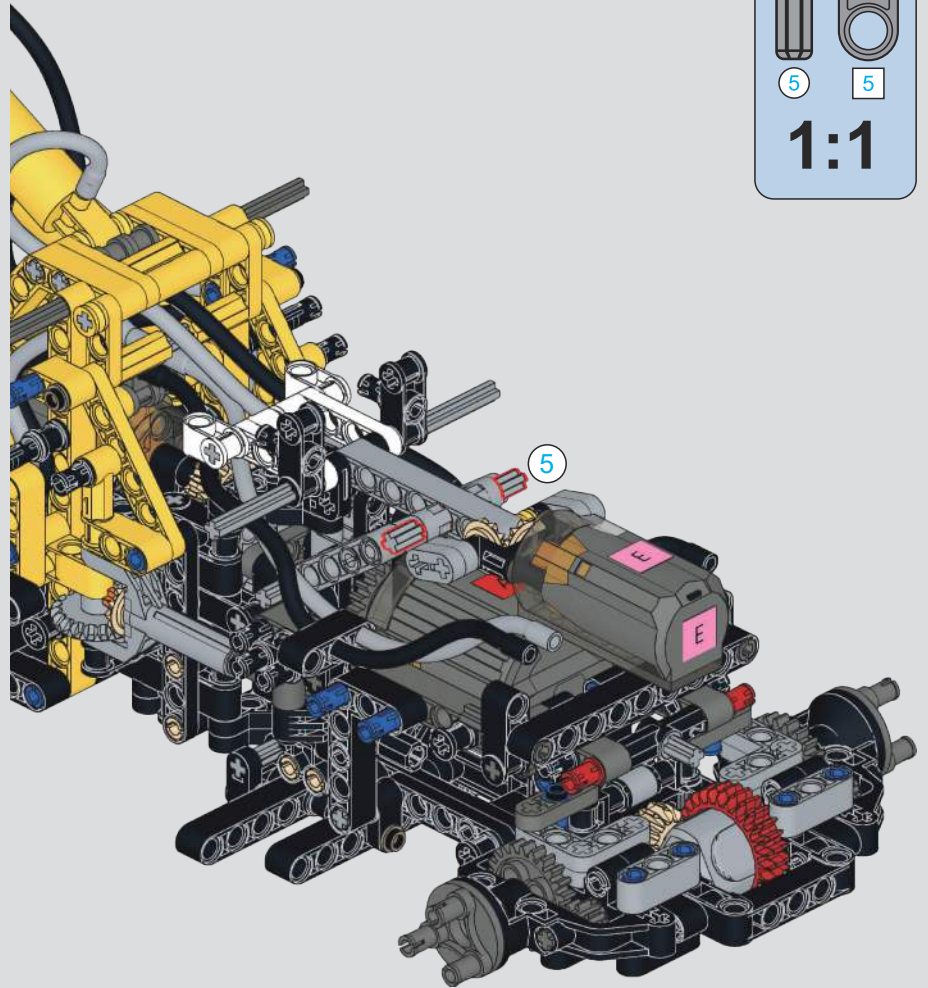

5 5

1:1

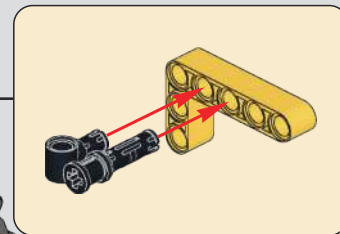
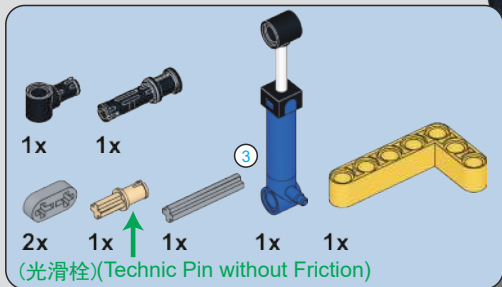

116

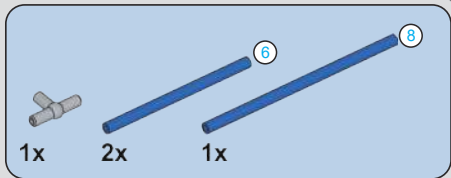
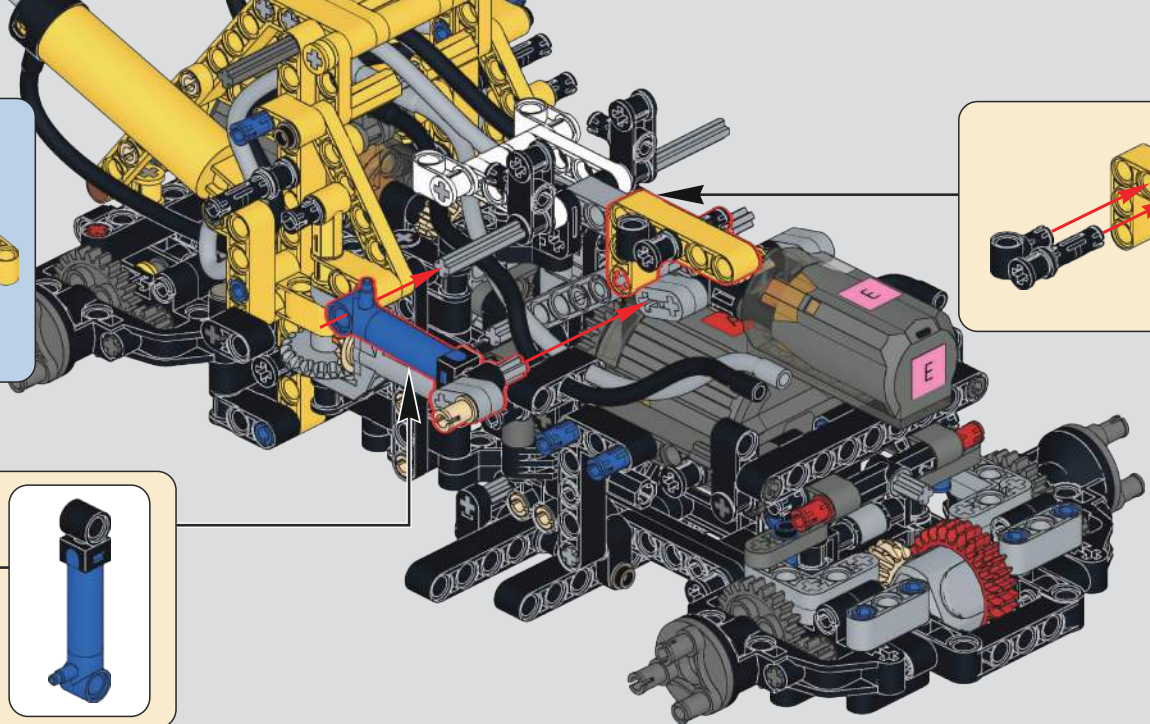
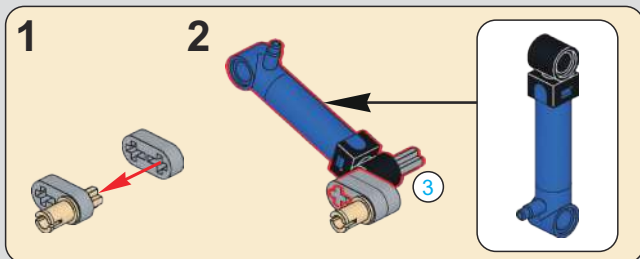

117

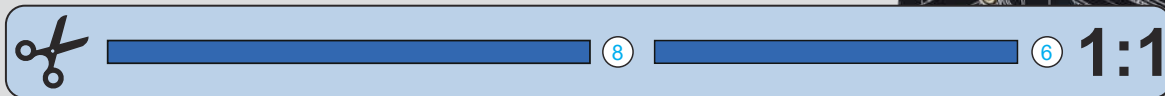
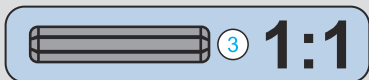
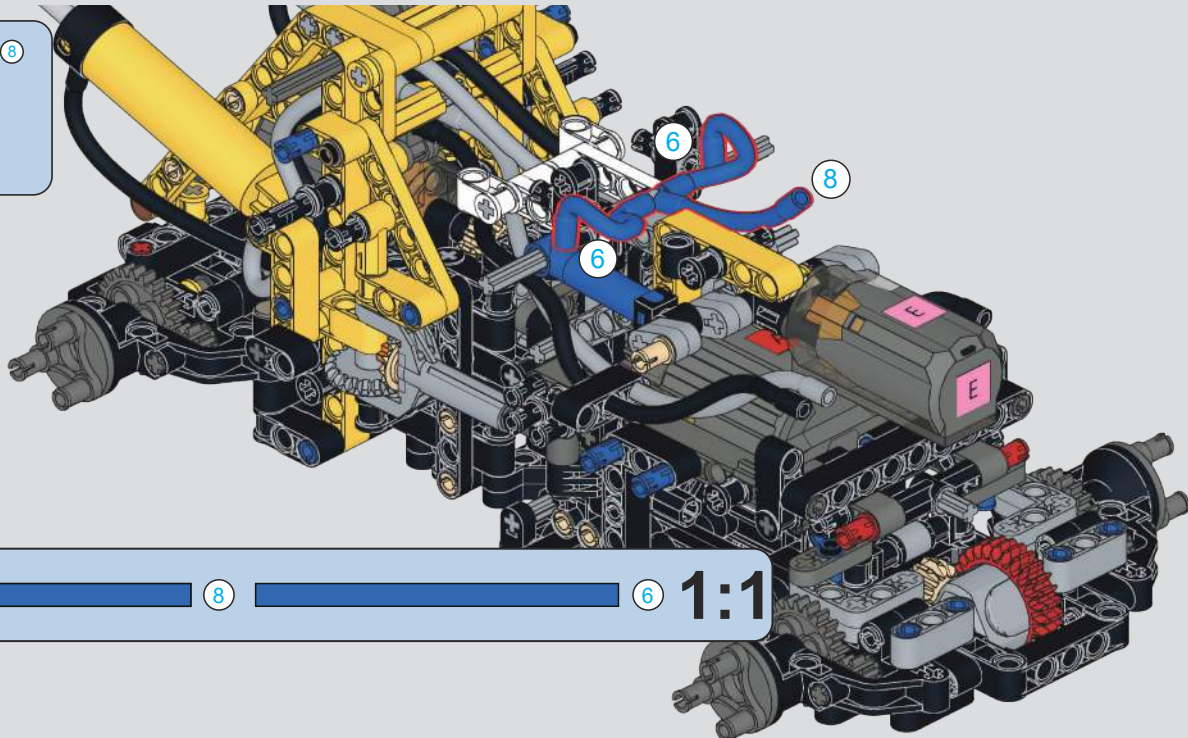

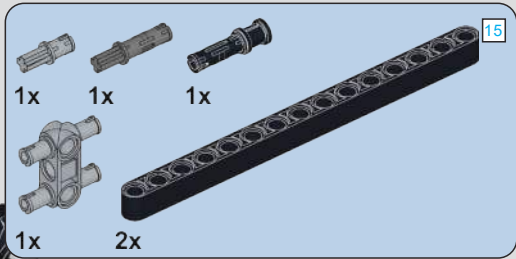

118

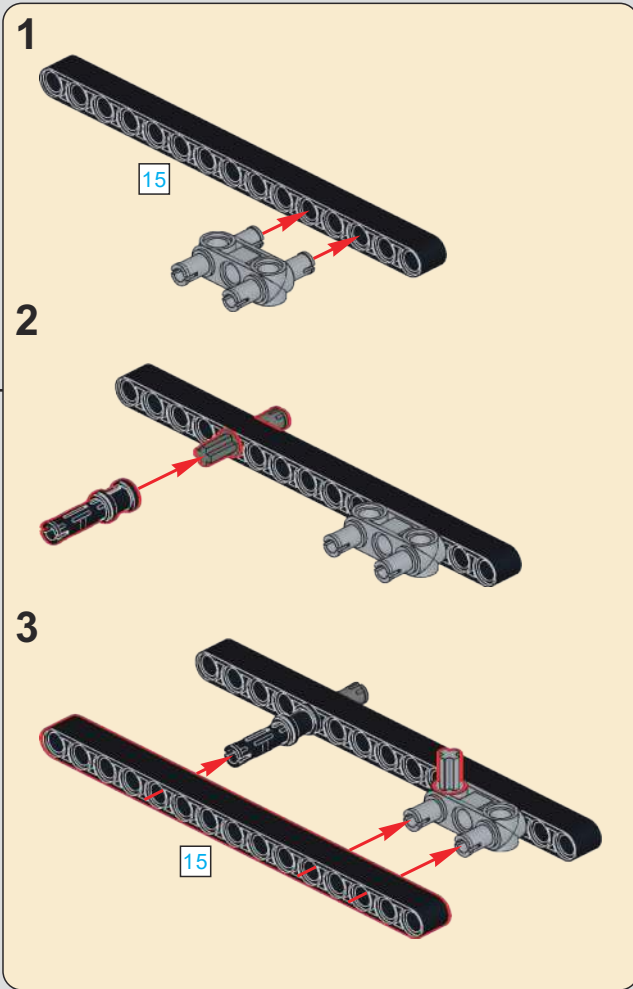
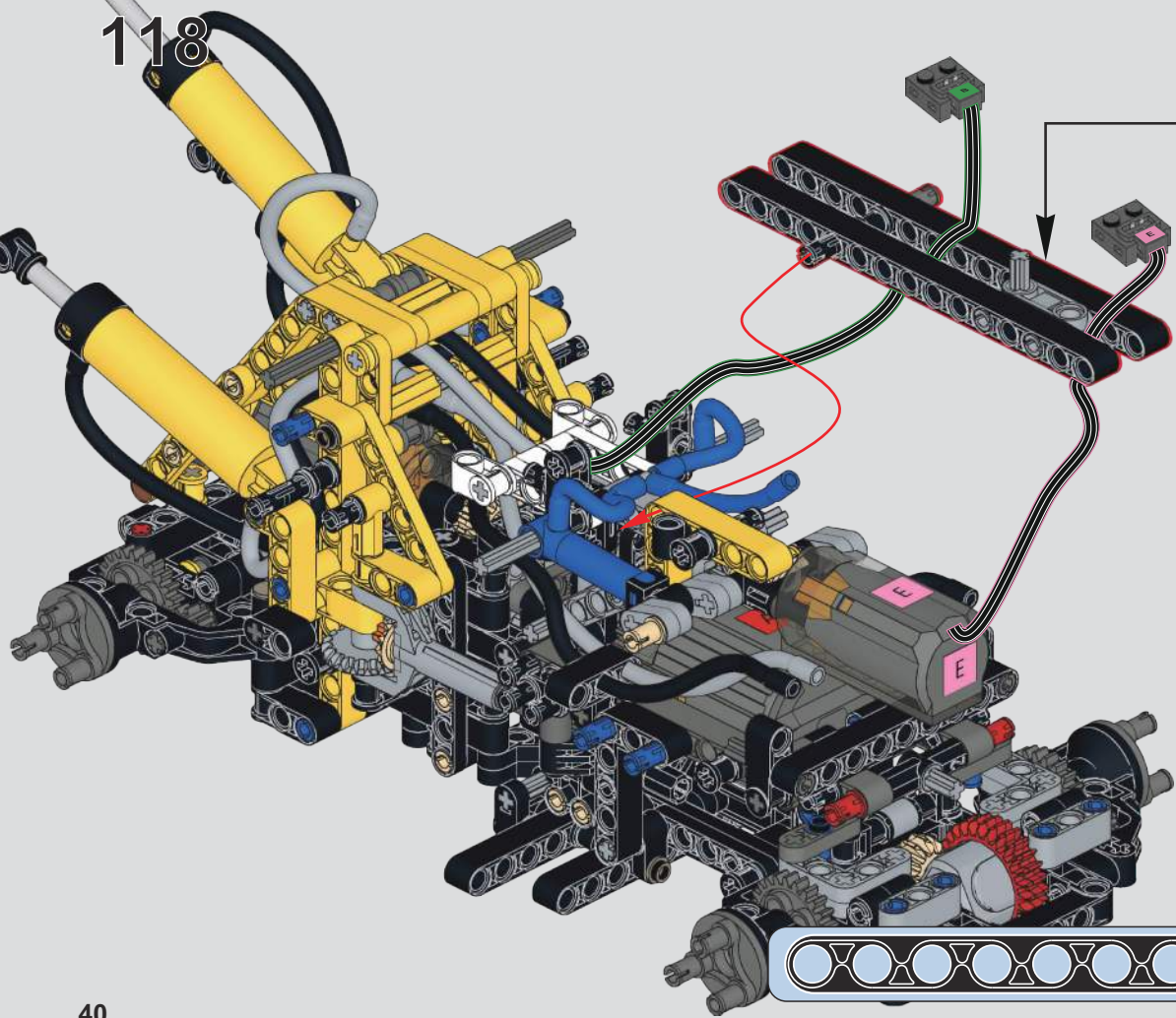

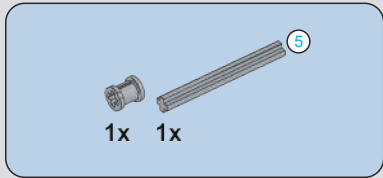

119

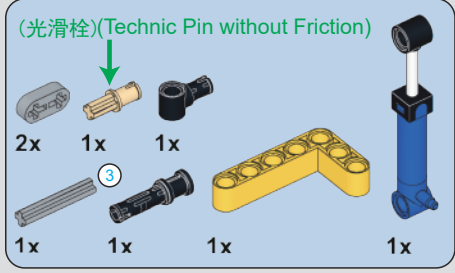
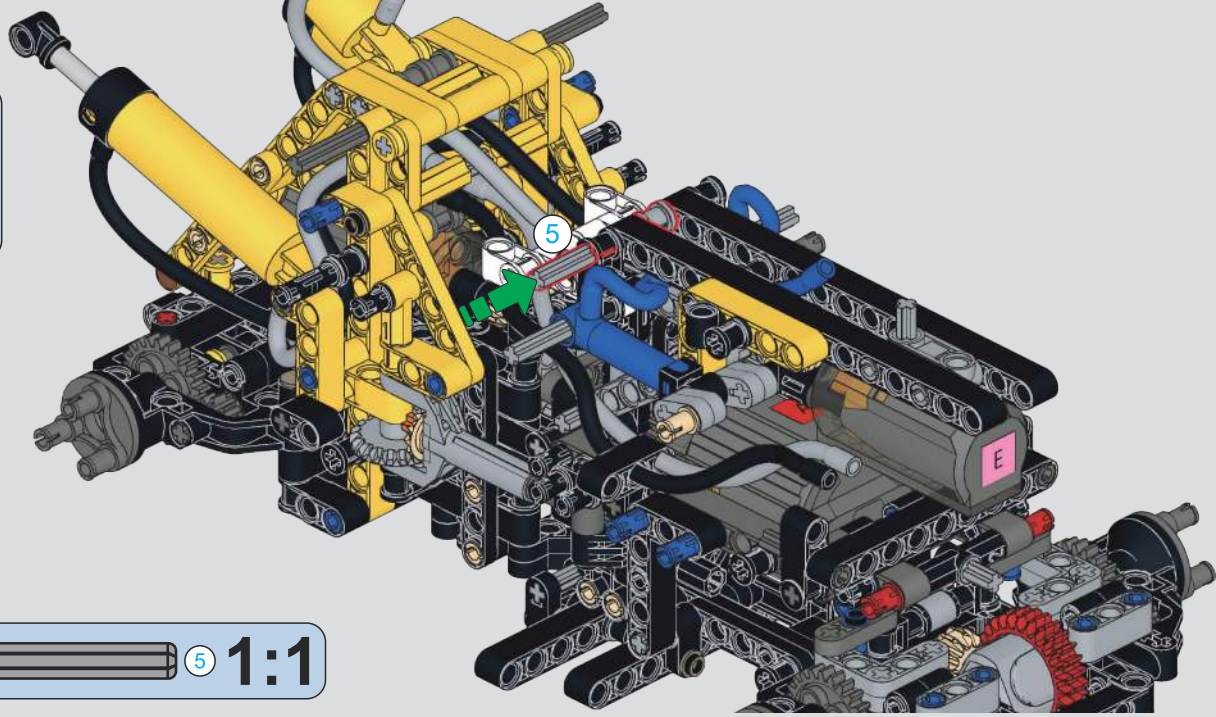

120

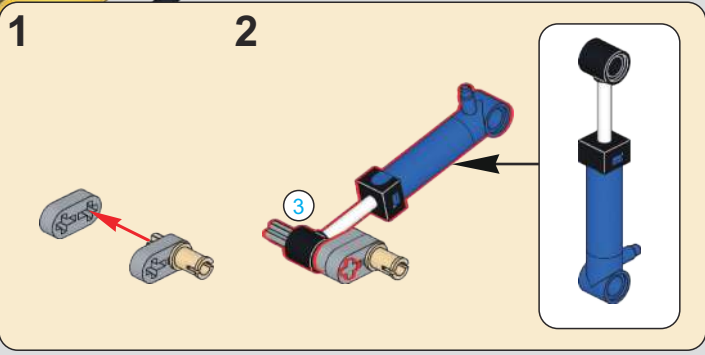
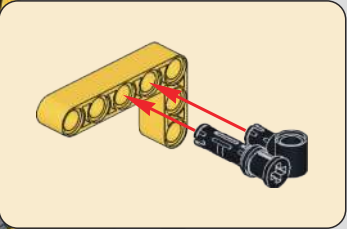
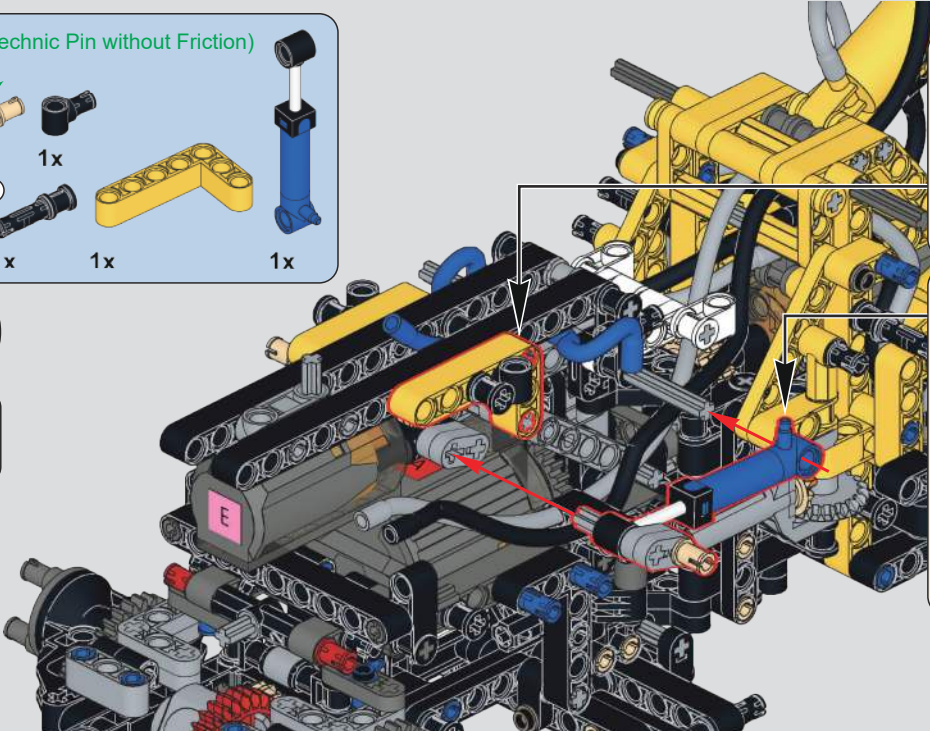

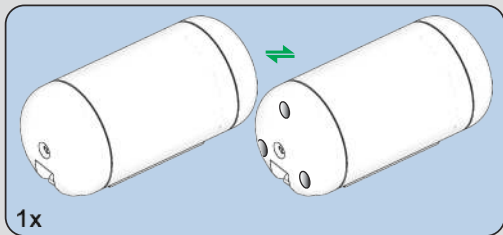

121

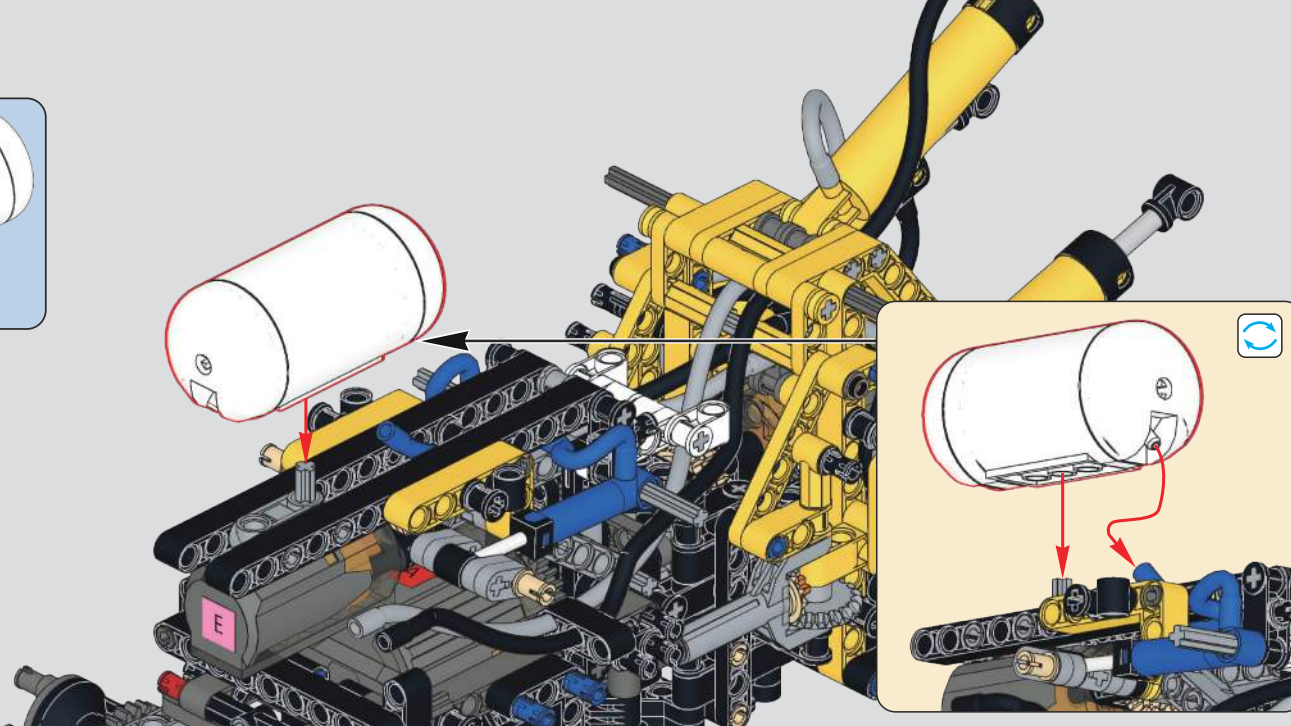

122

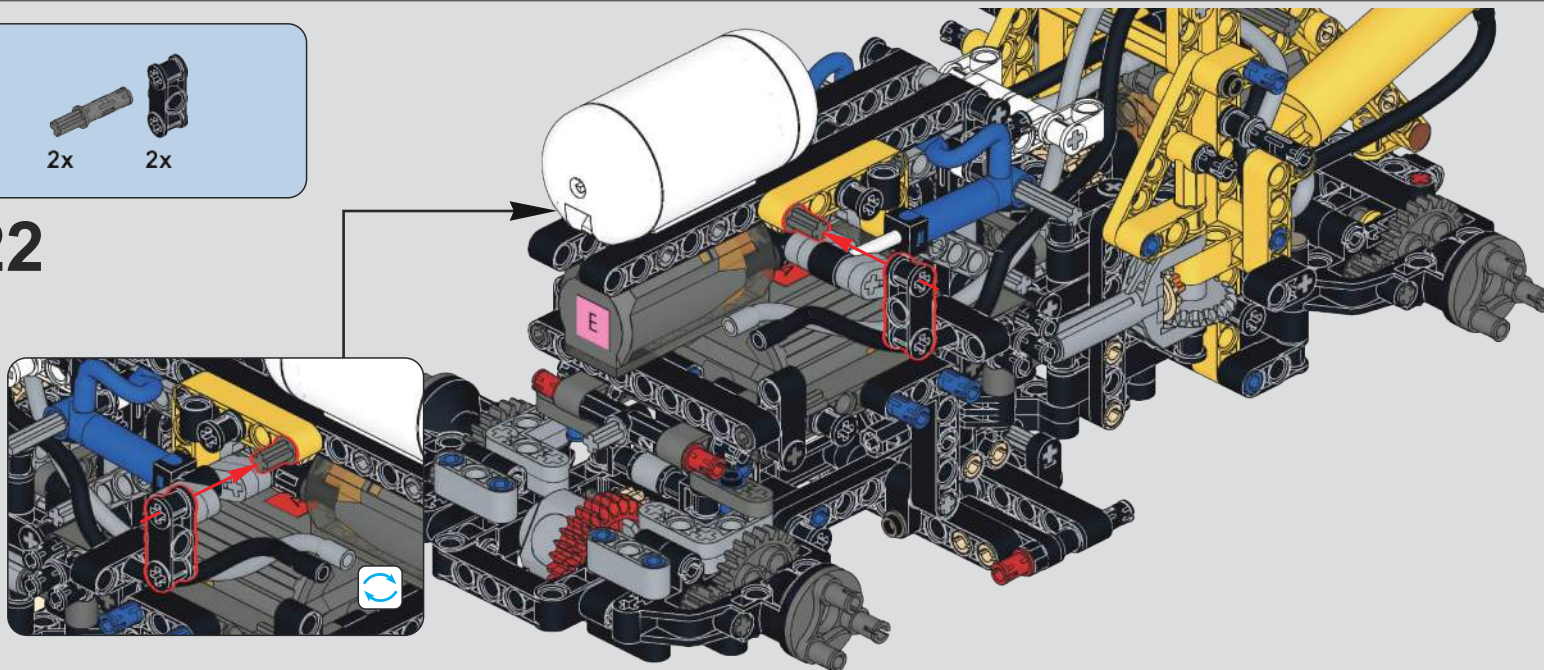

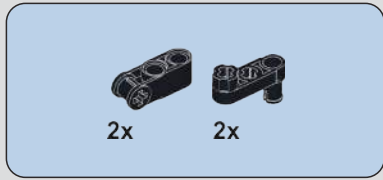

123

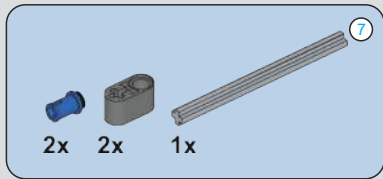
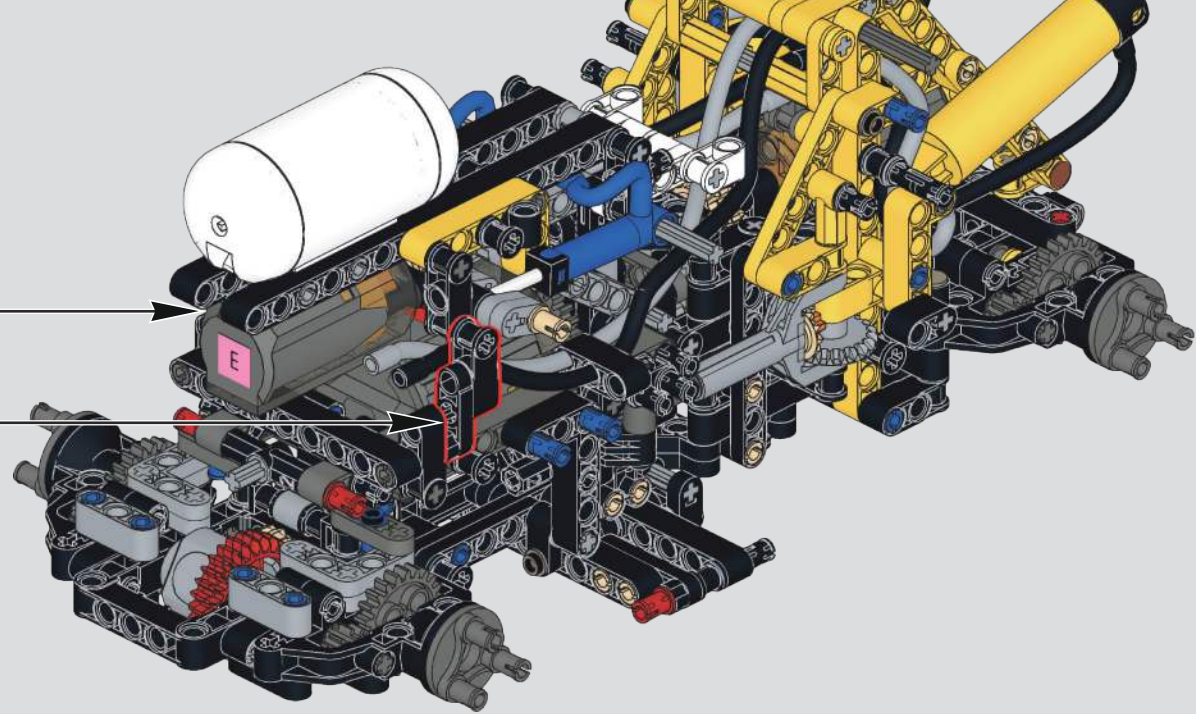
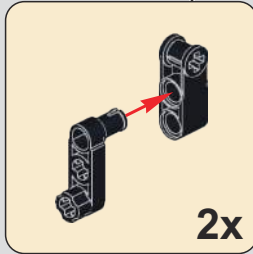
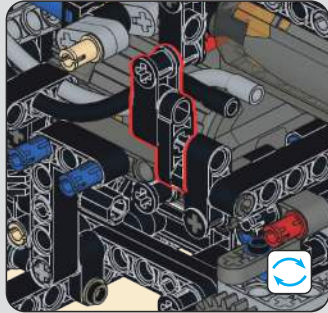

124

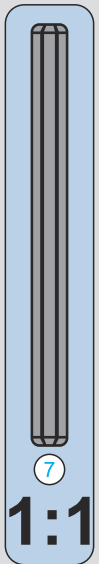
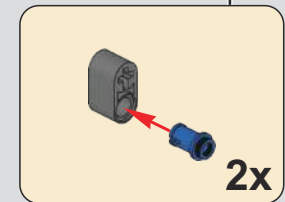
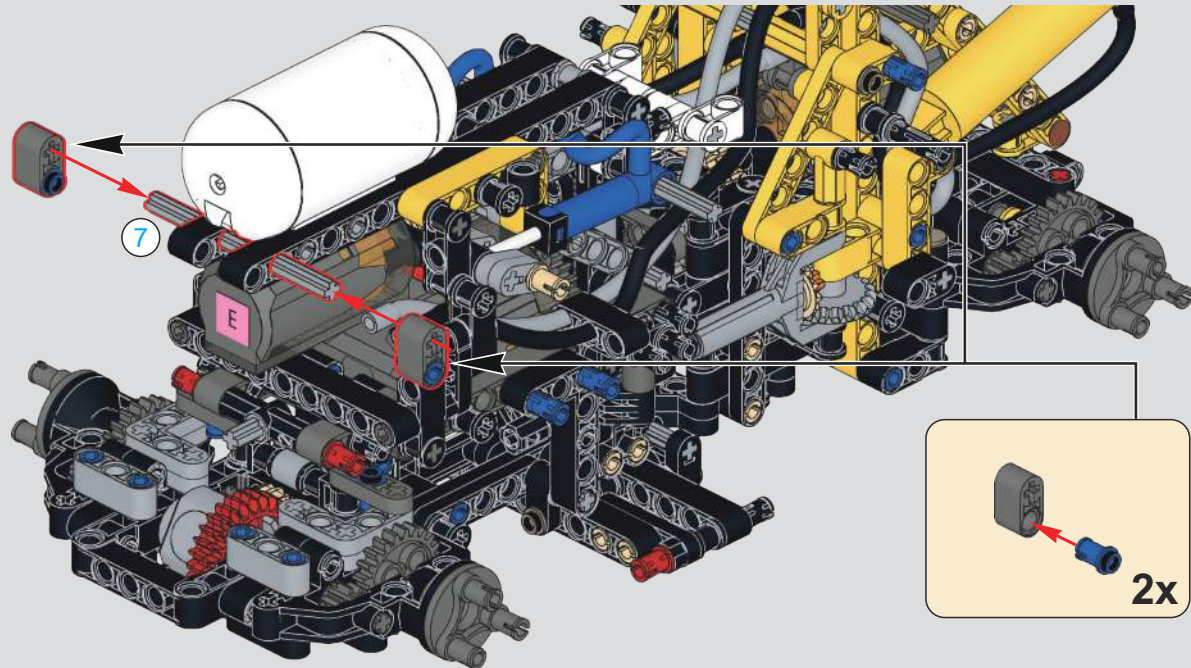

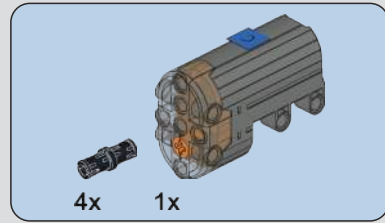
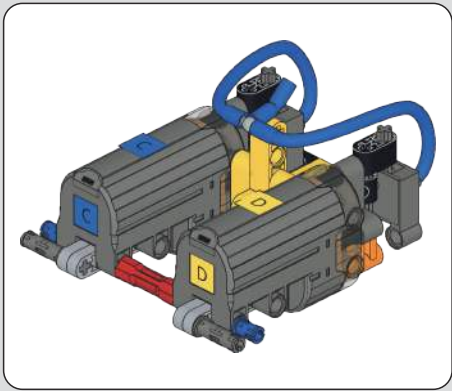

125

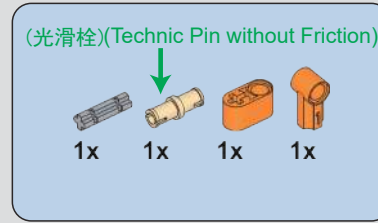
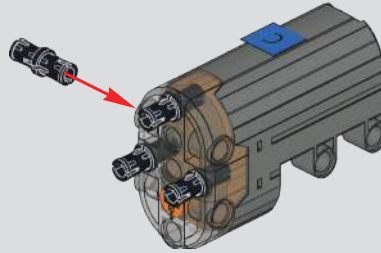

126

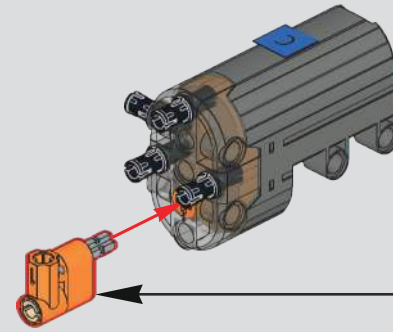
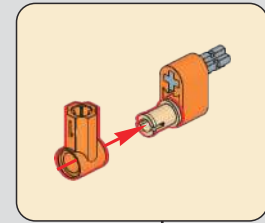

127

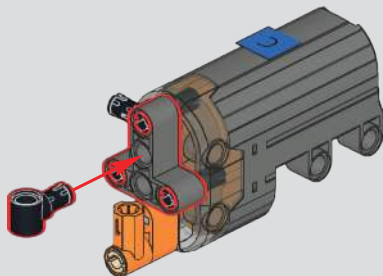
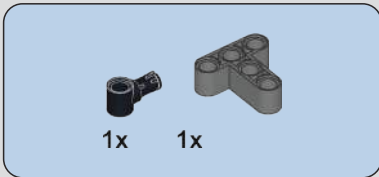

128

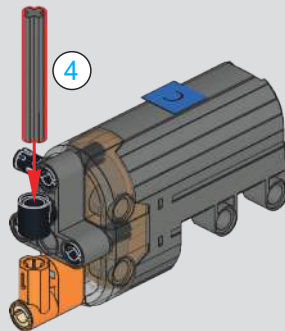
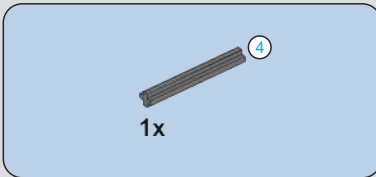

129

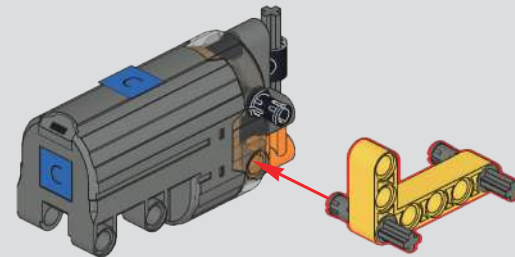
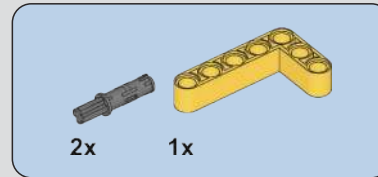

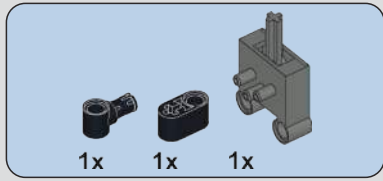

130

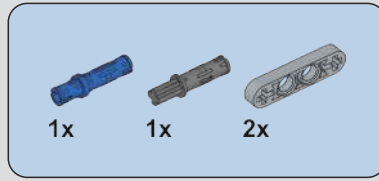
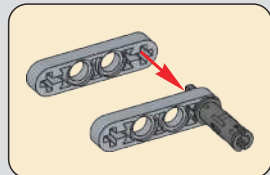
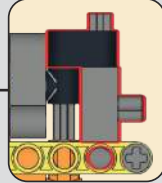
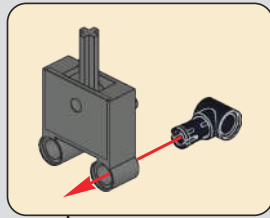
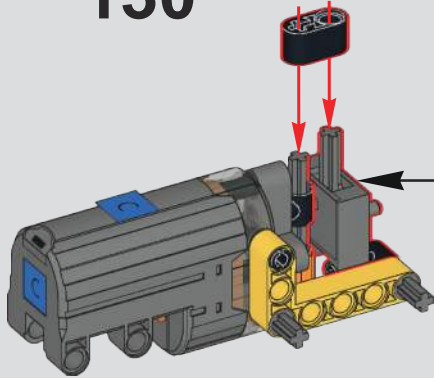

131

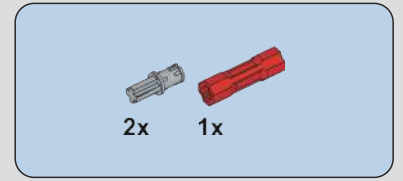
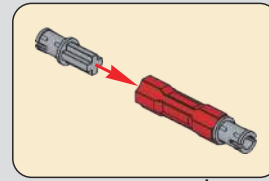
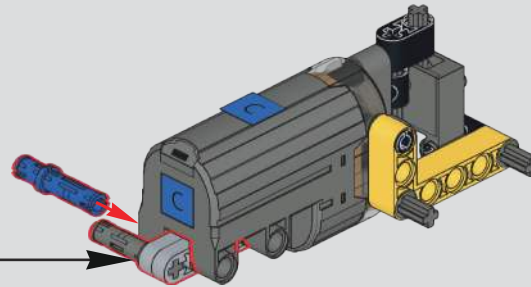

132

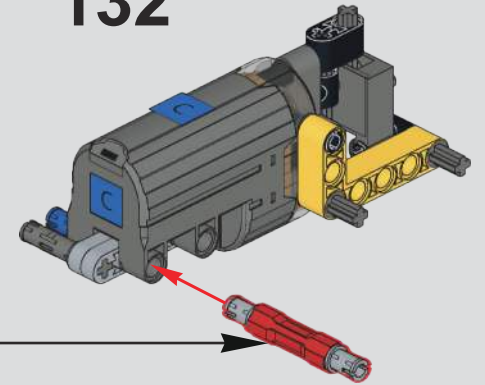

133

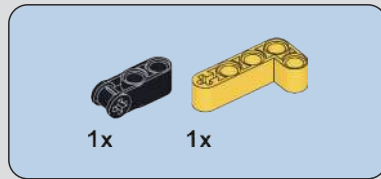
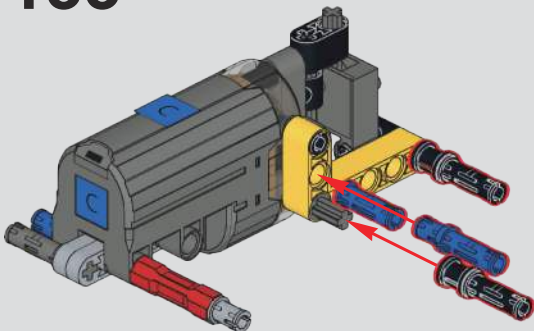

134

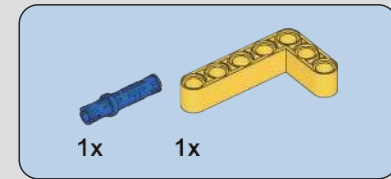
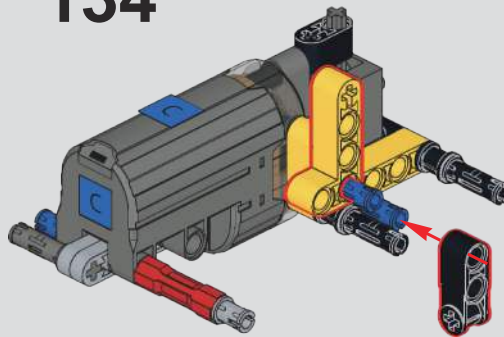

135

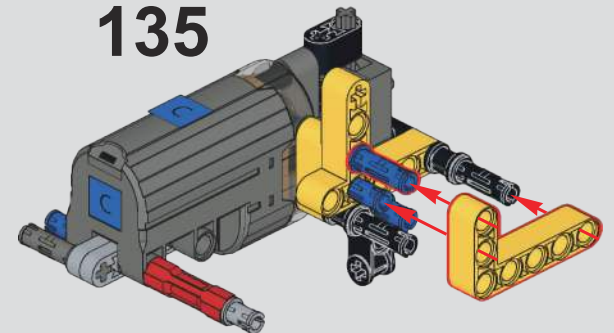

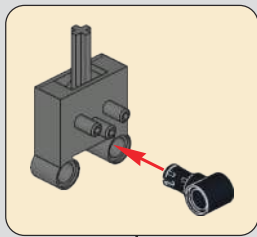
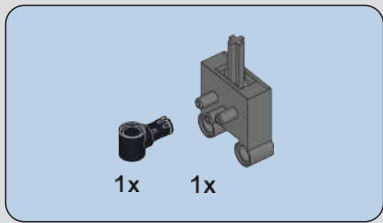

136

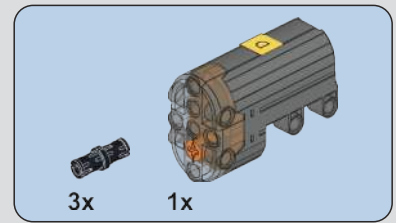
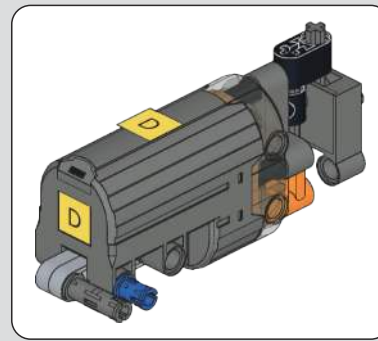
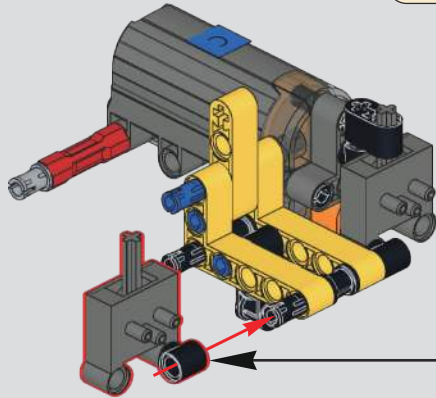

137

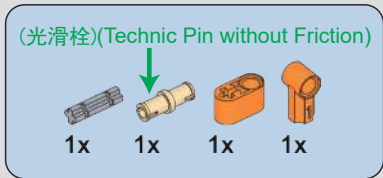
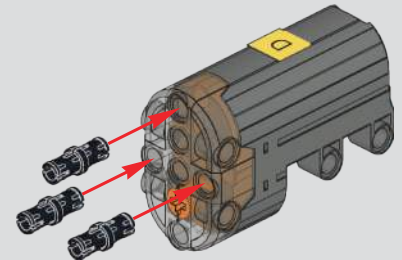

138

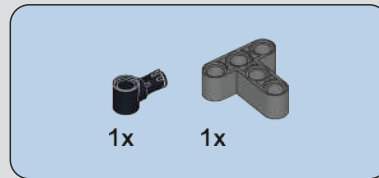
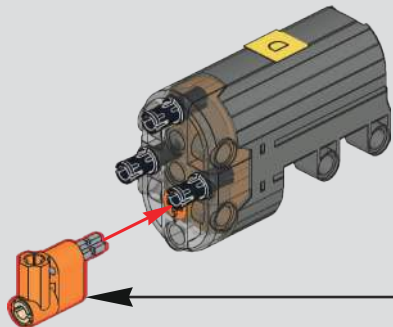
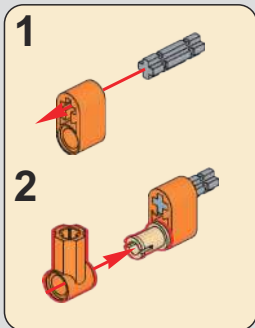

139

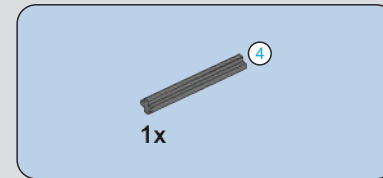
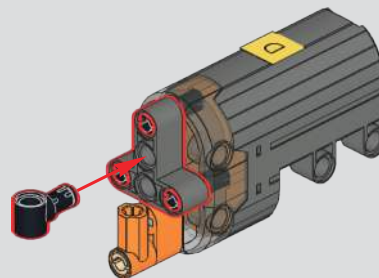

140

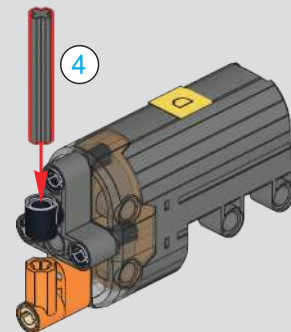

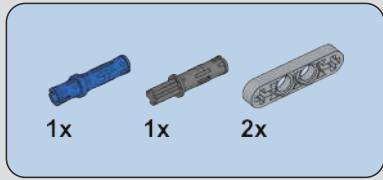

141

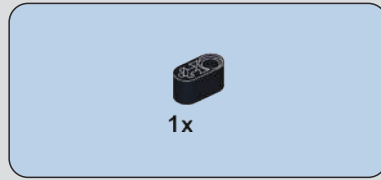
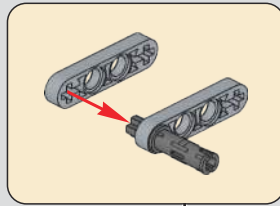
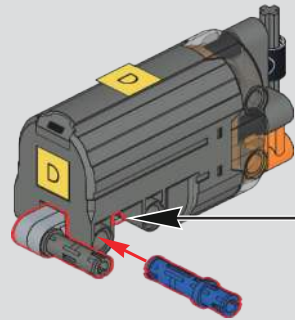

142

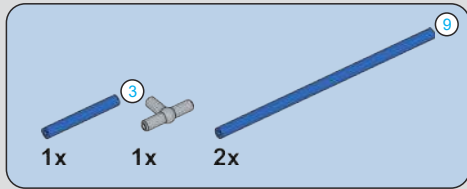
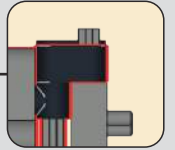
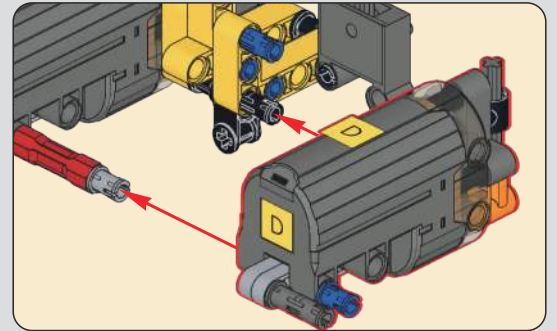
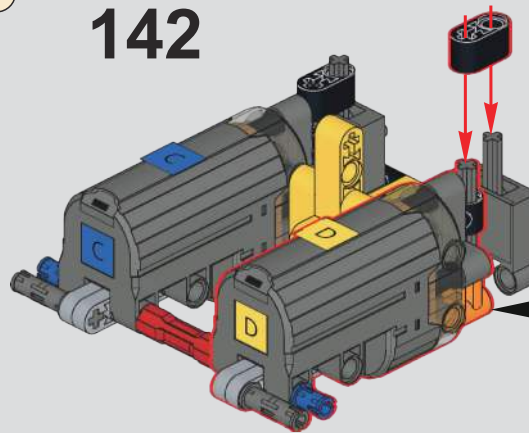

143

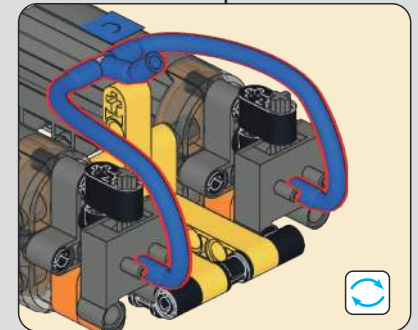
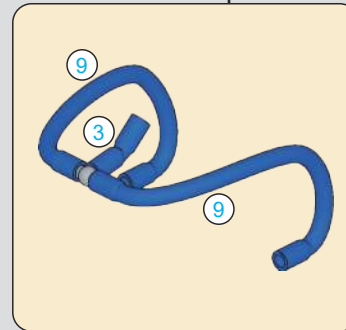
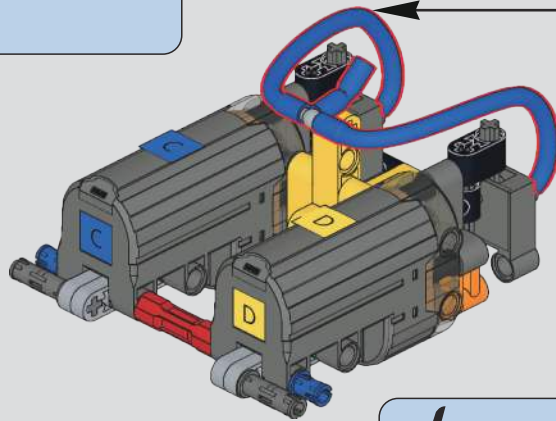

3



9

1:1

144

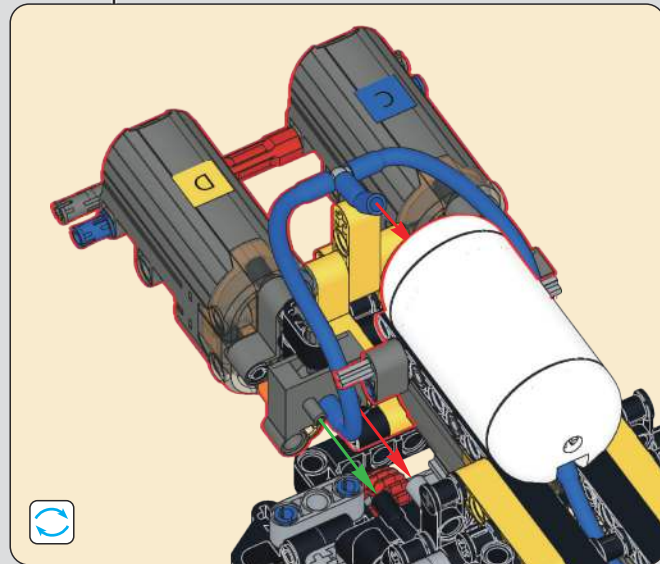
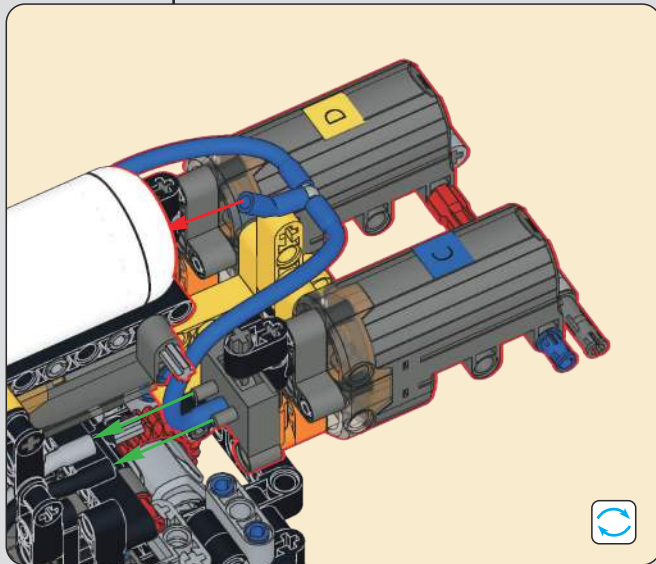
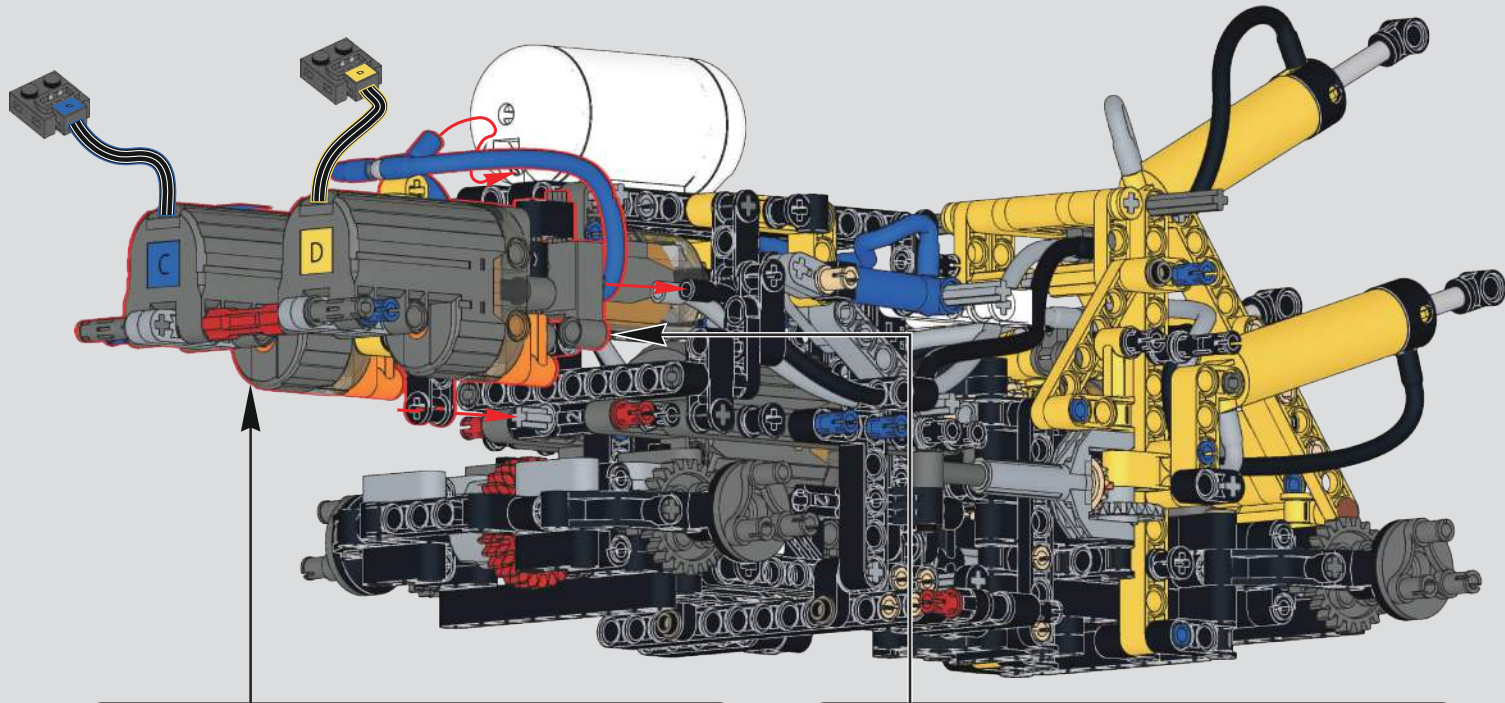

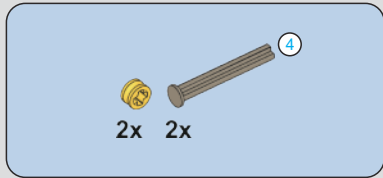

145

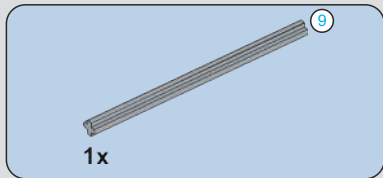
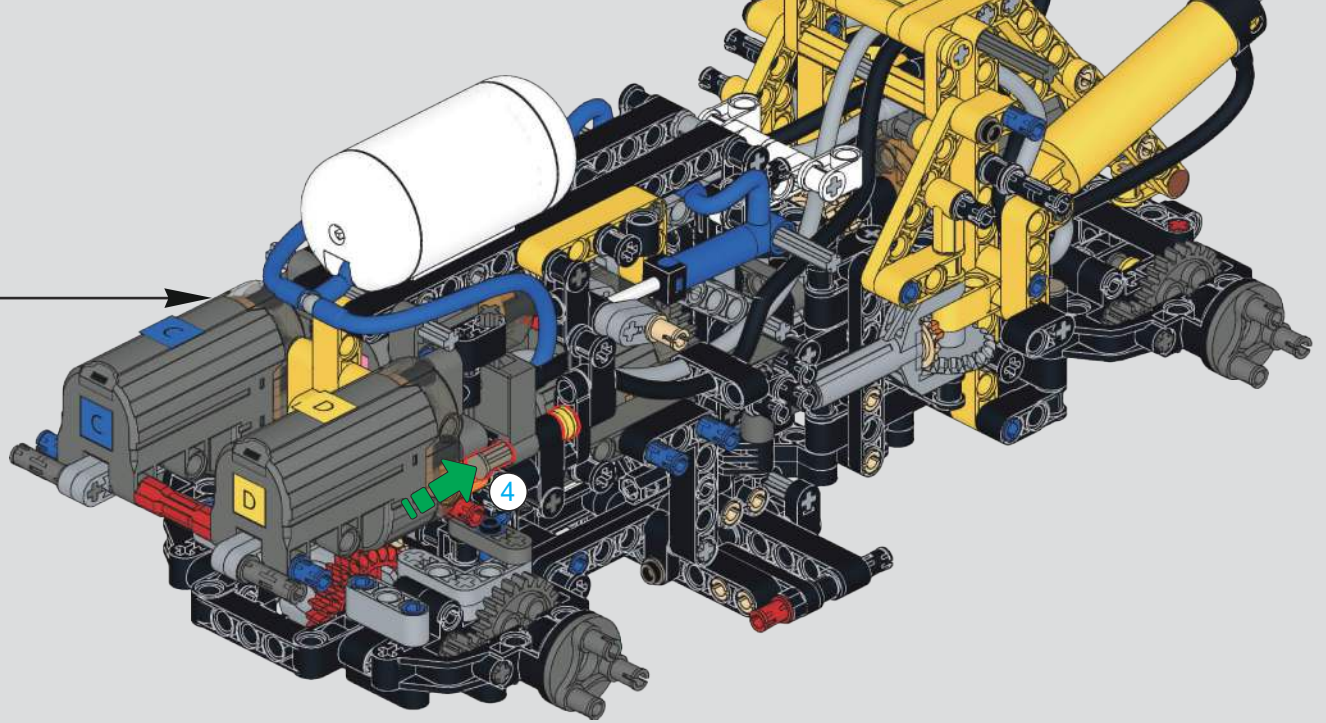
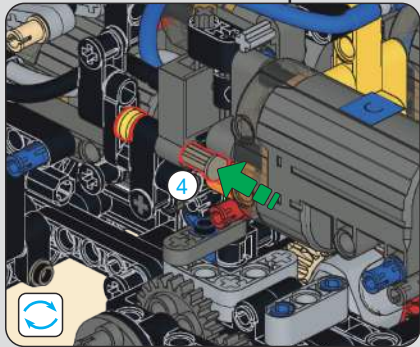

146

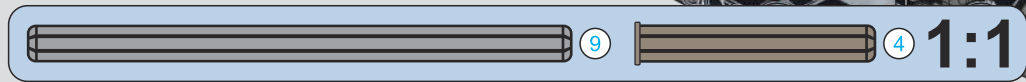
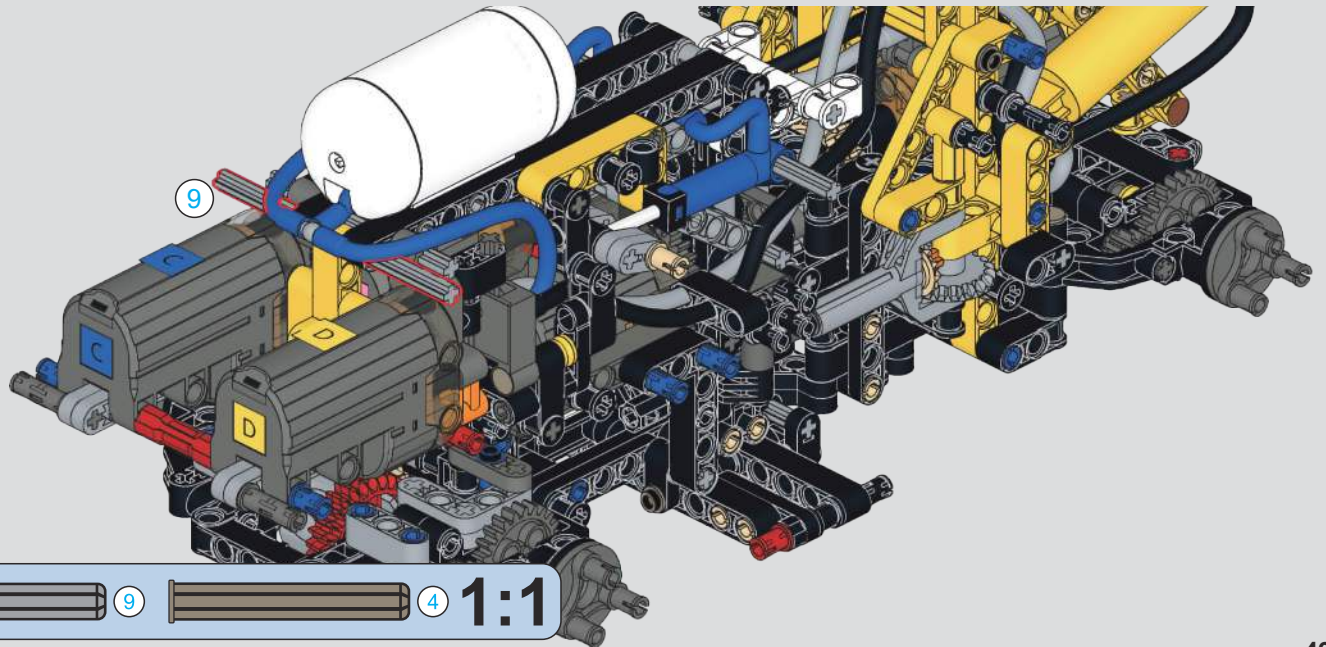

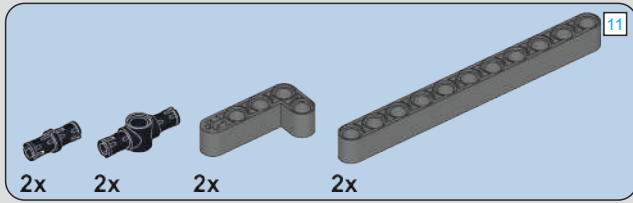

147

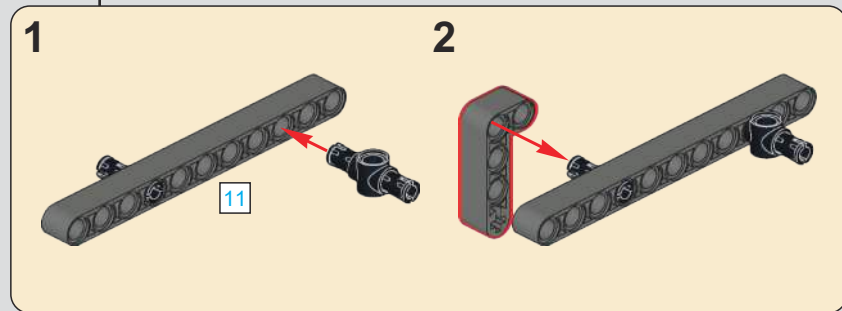
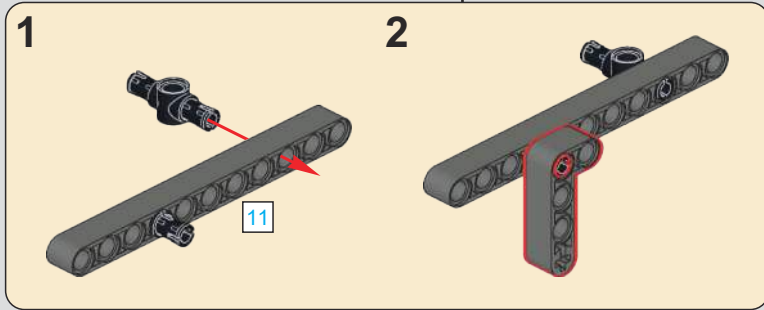
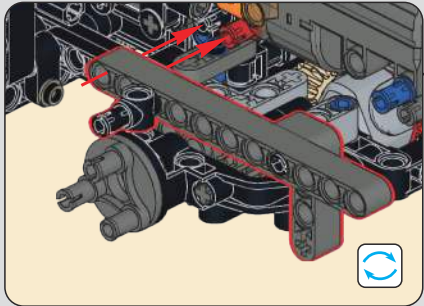
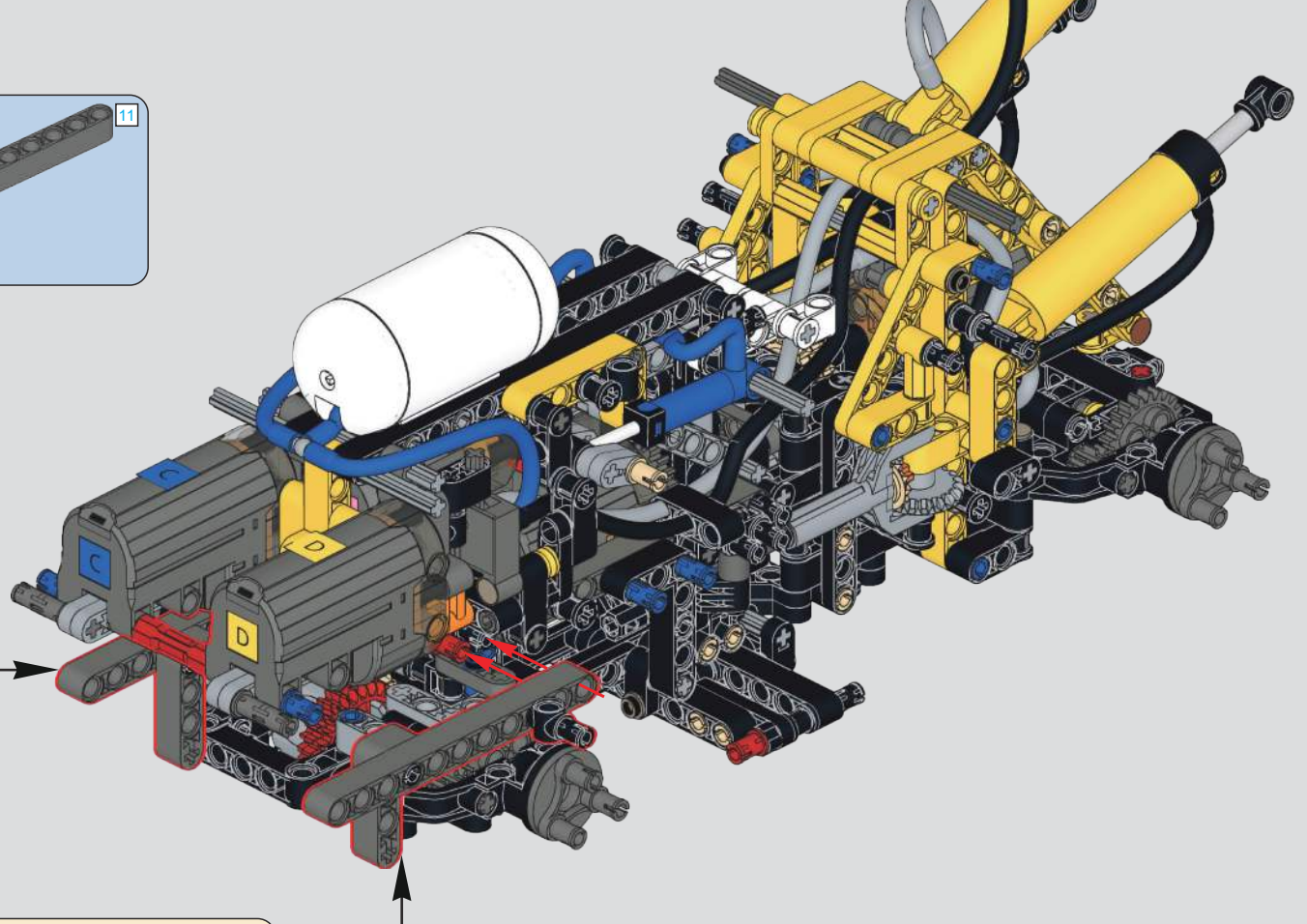

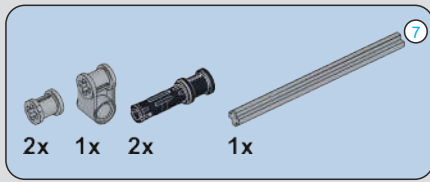

148

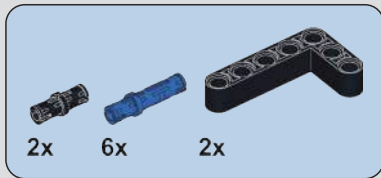
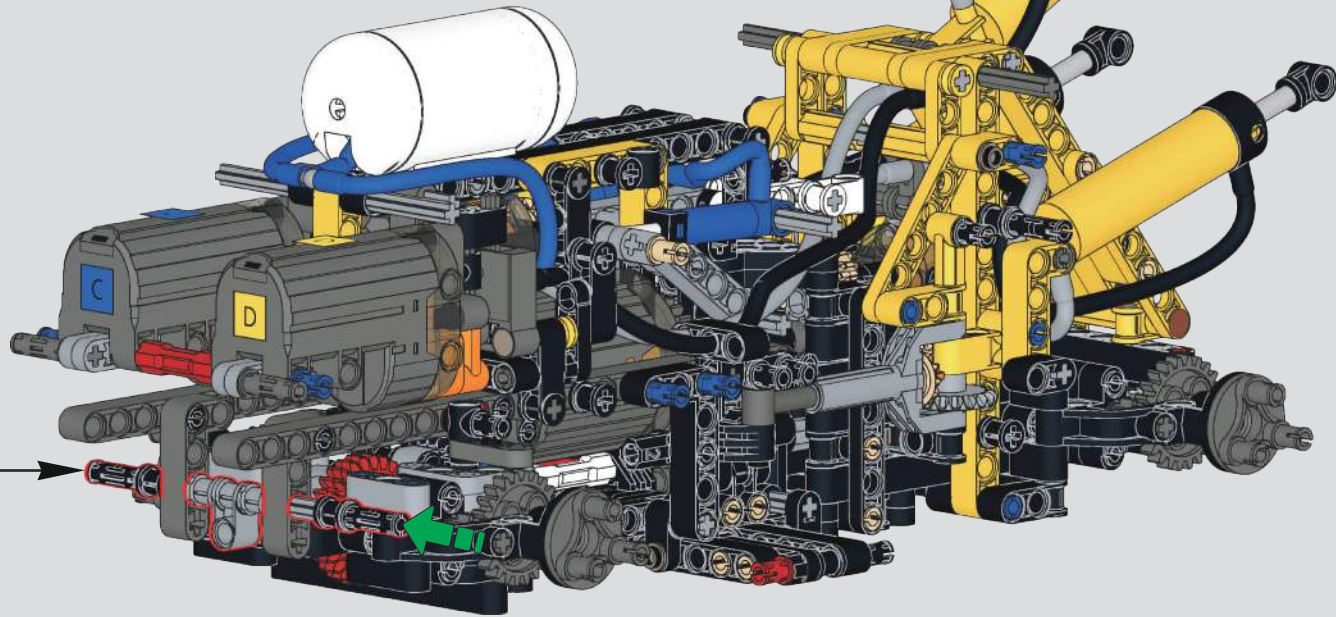
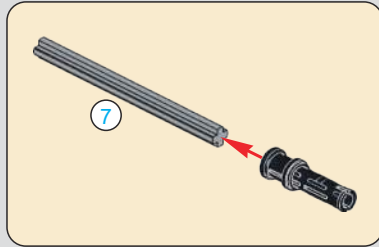

149

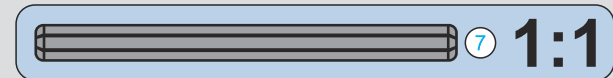
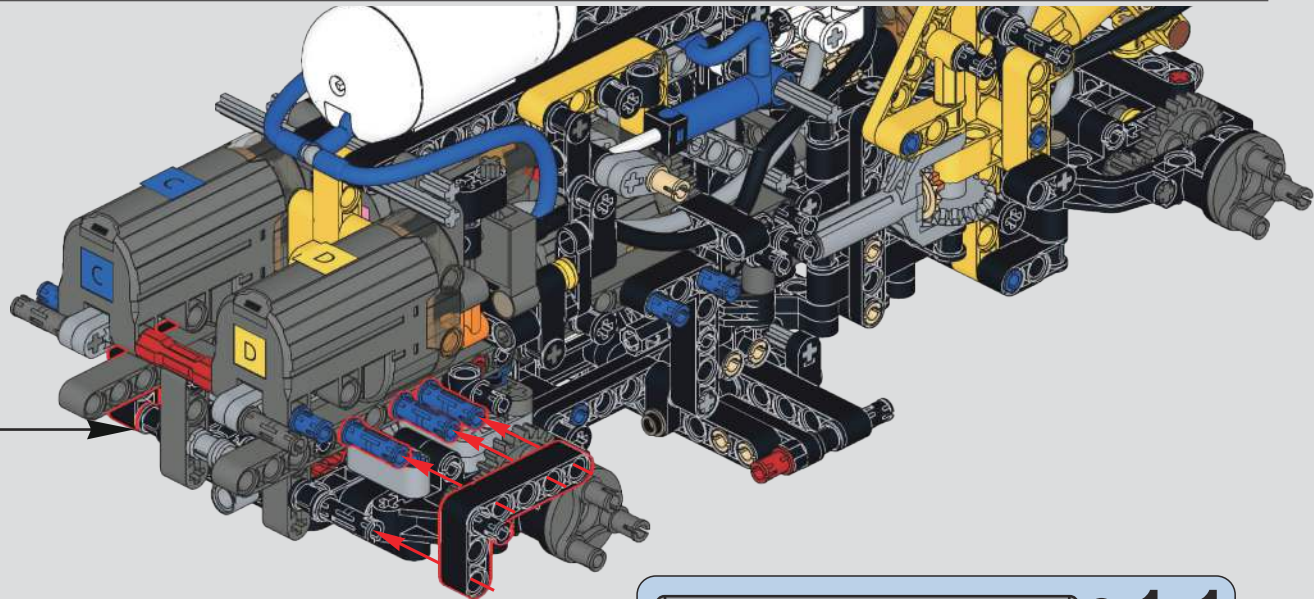
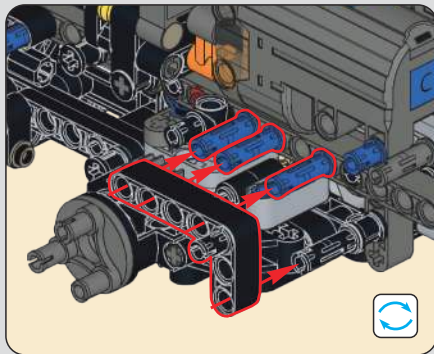

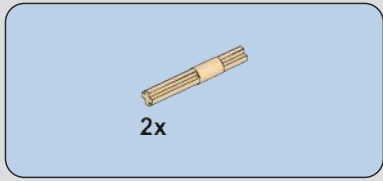

150

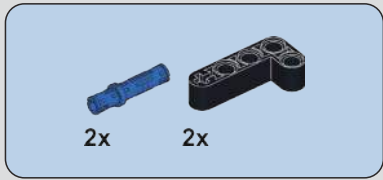
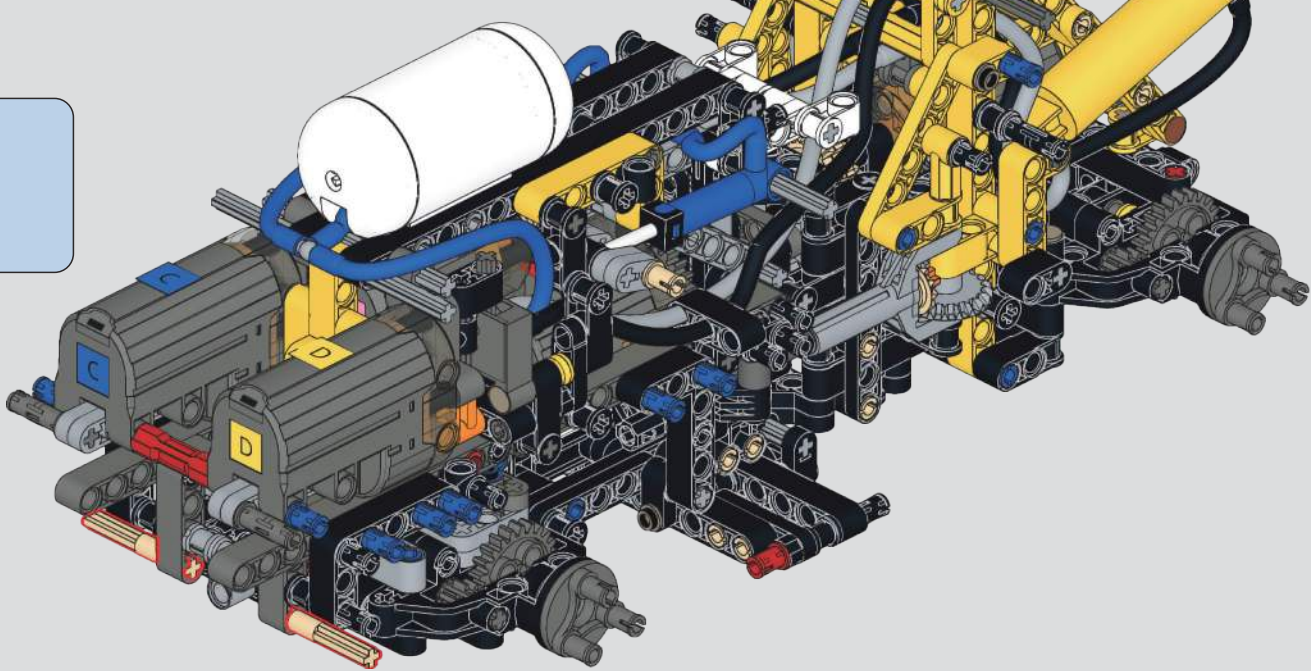

151

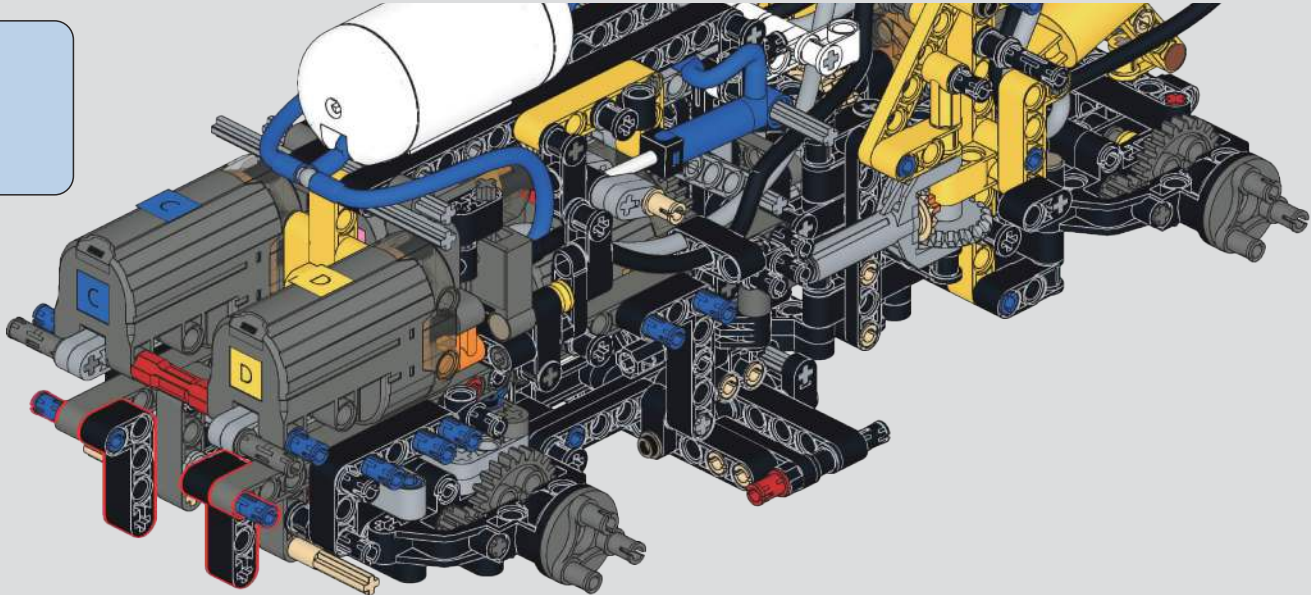

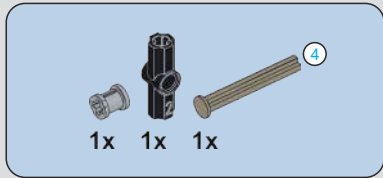

152

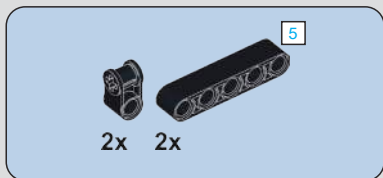
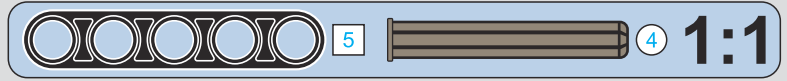
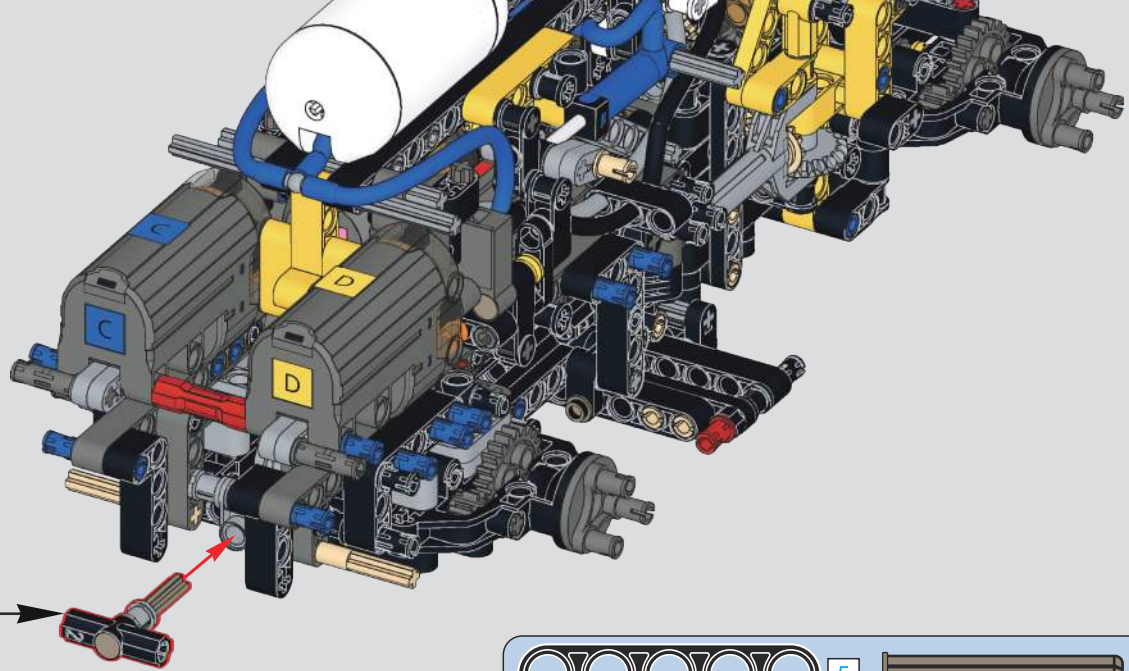
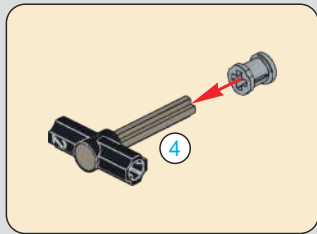

153

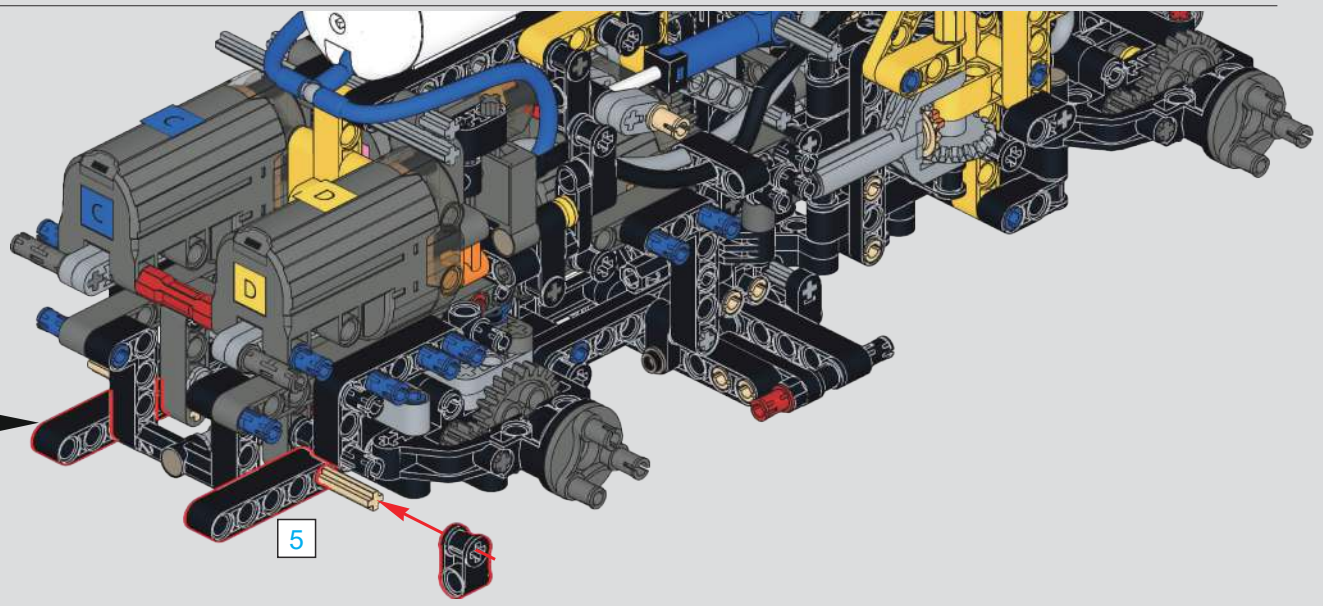
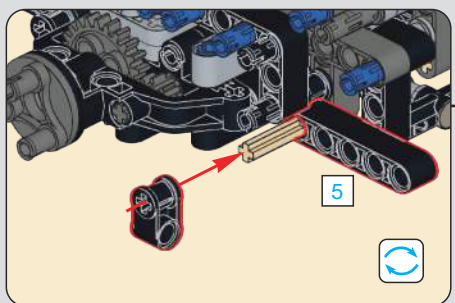

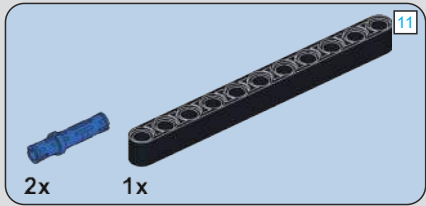

154

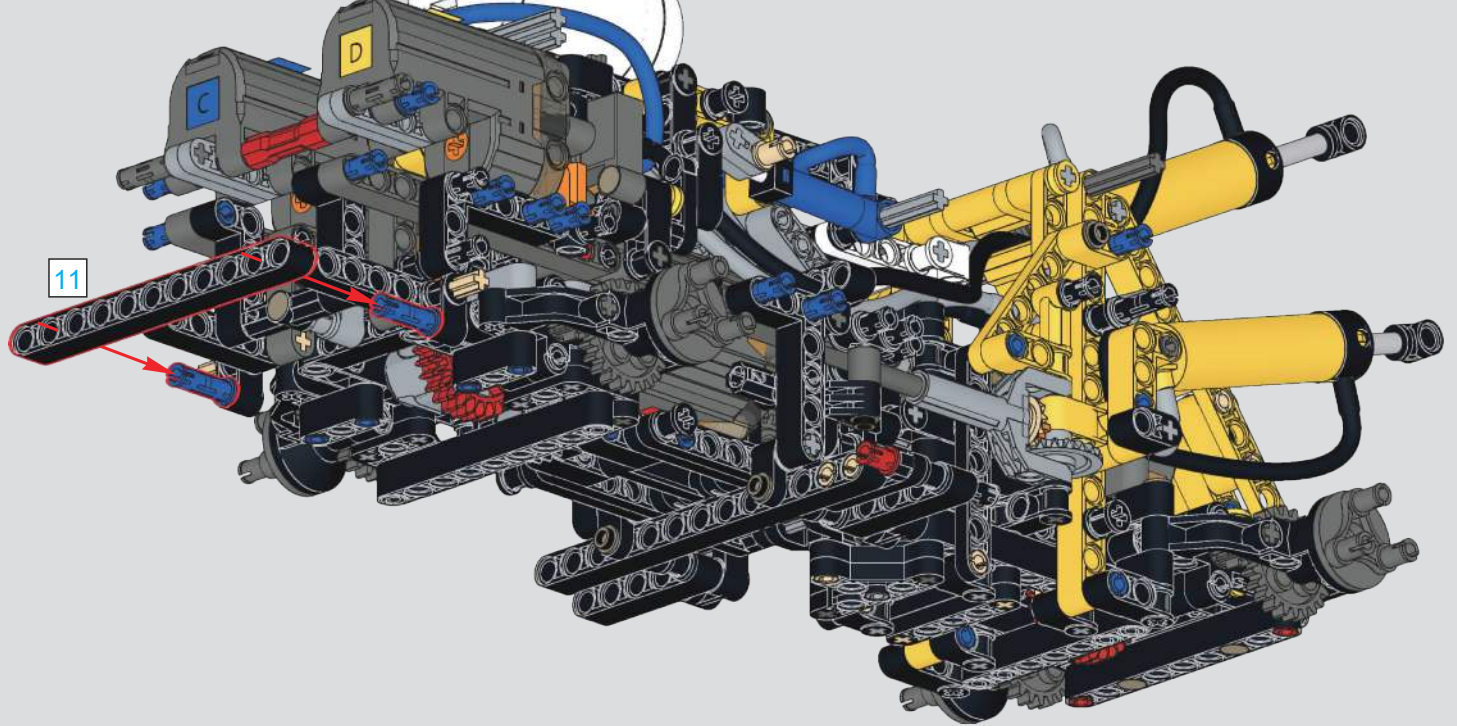

155

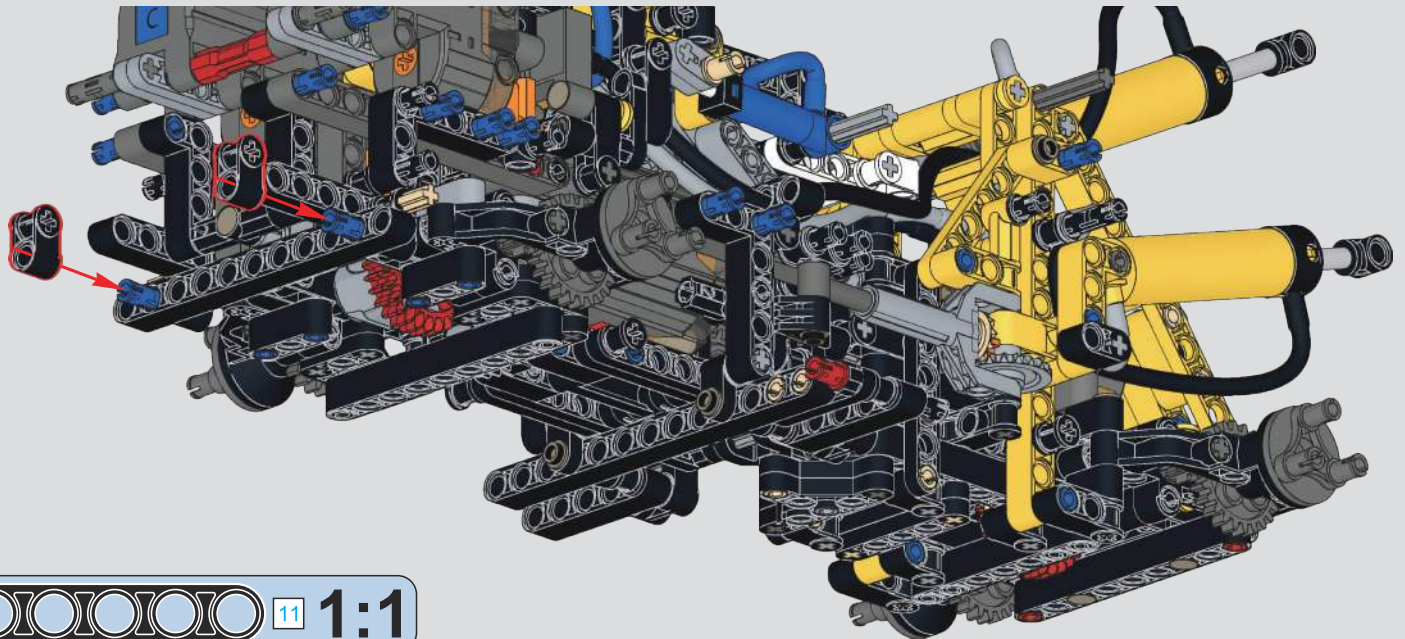

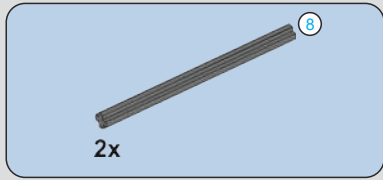

156

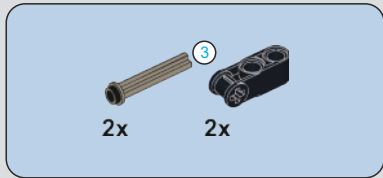
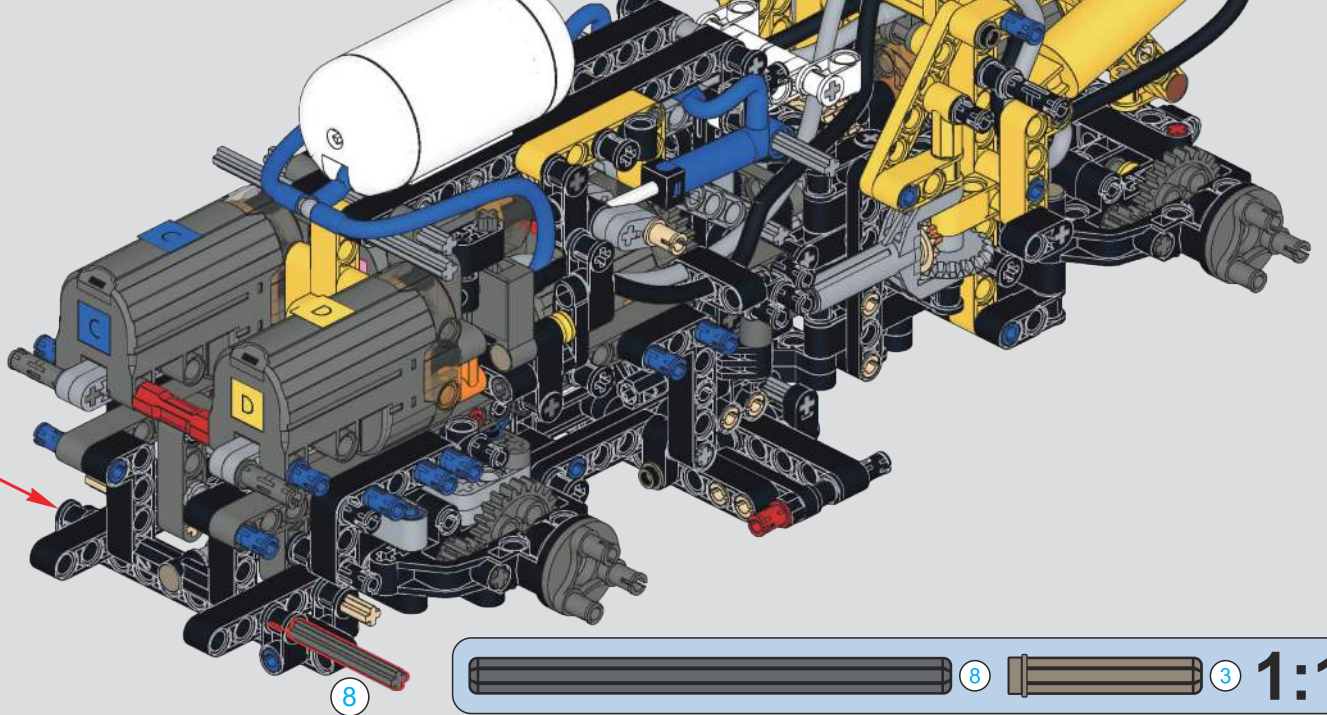
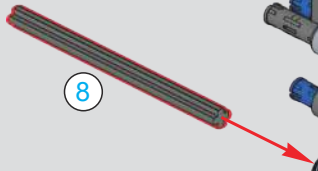

157

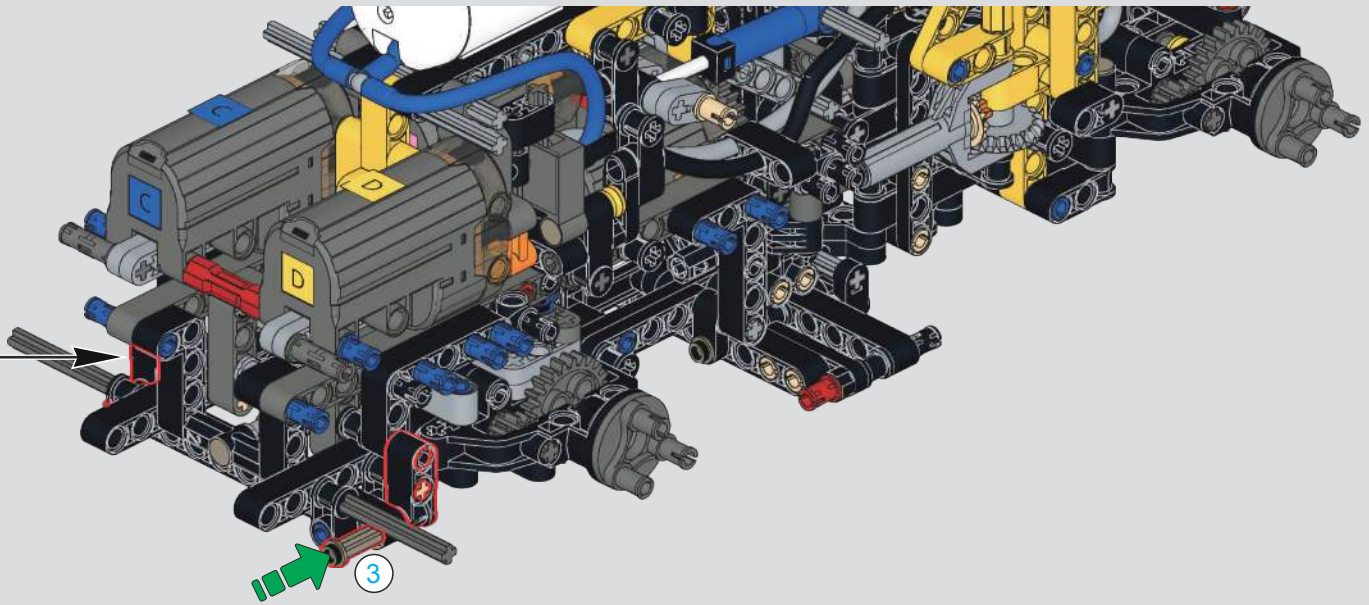
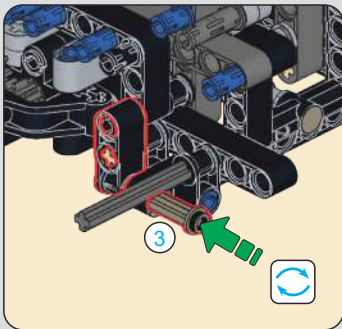

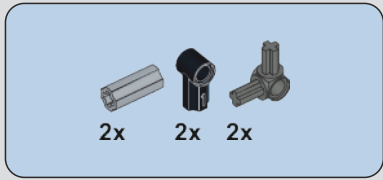

158

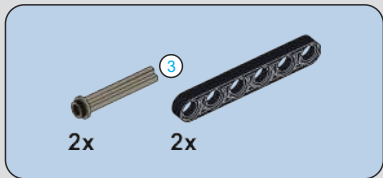
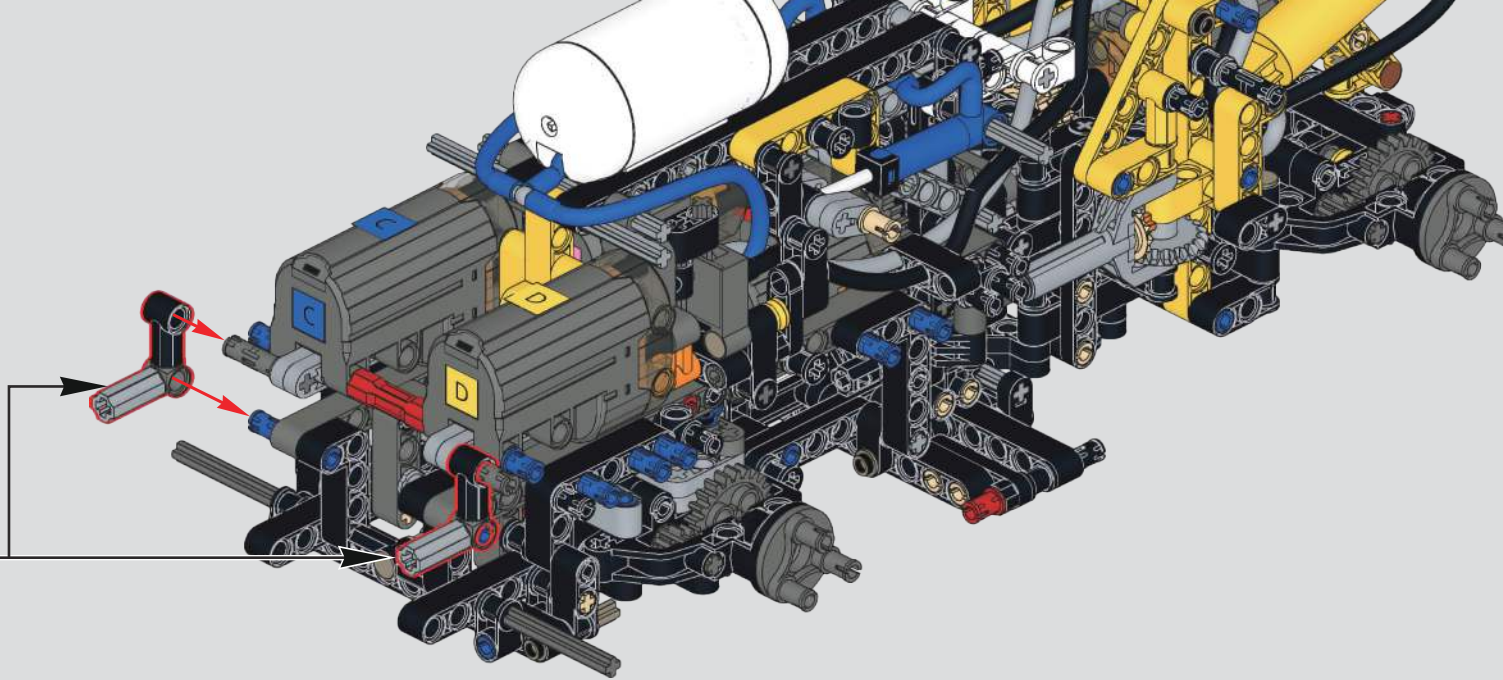
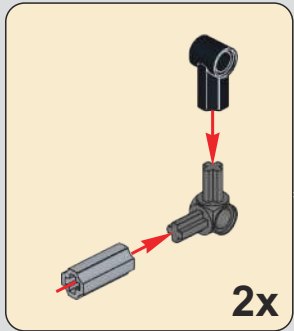

159

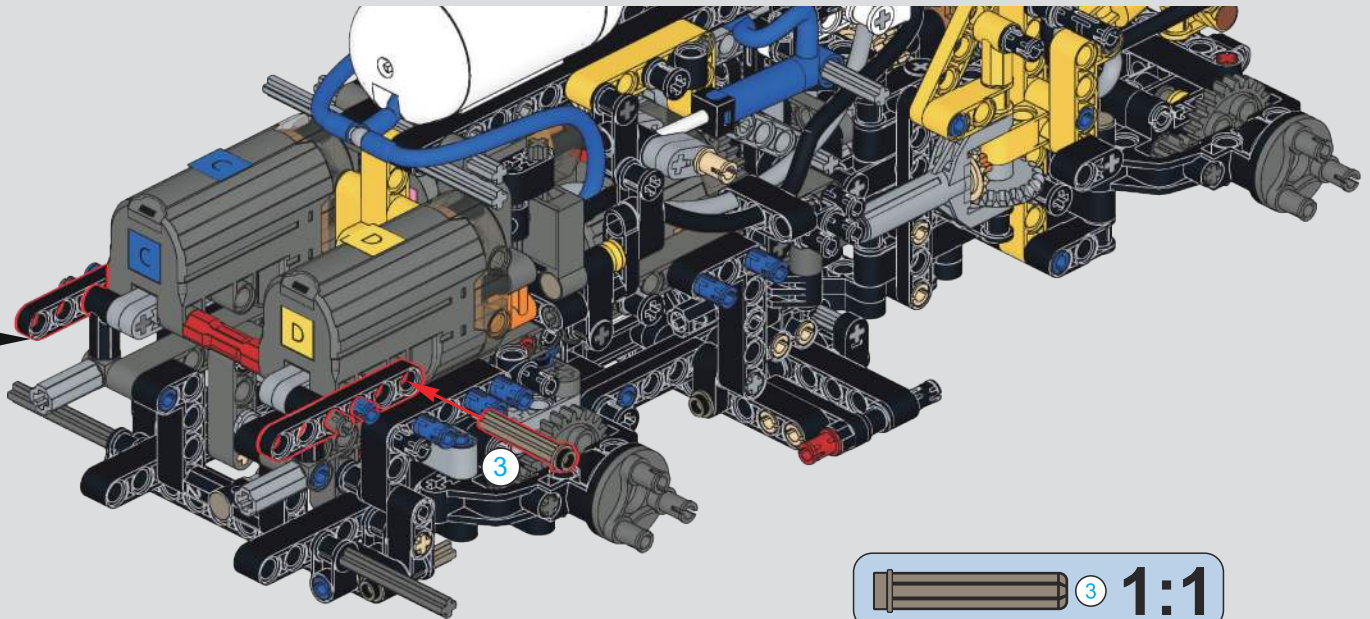
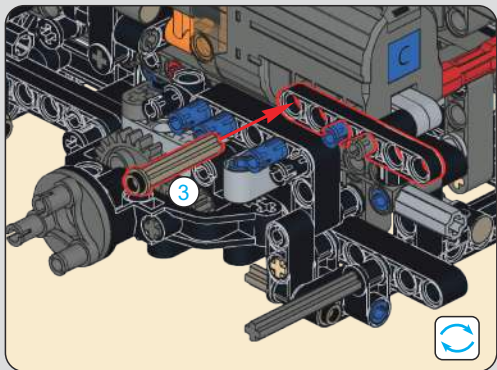

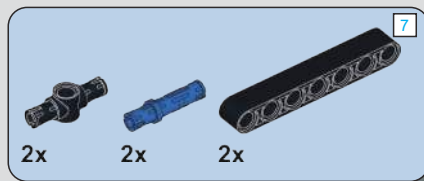

160

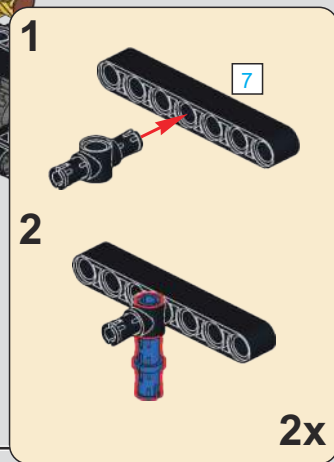
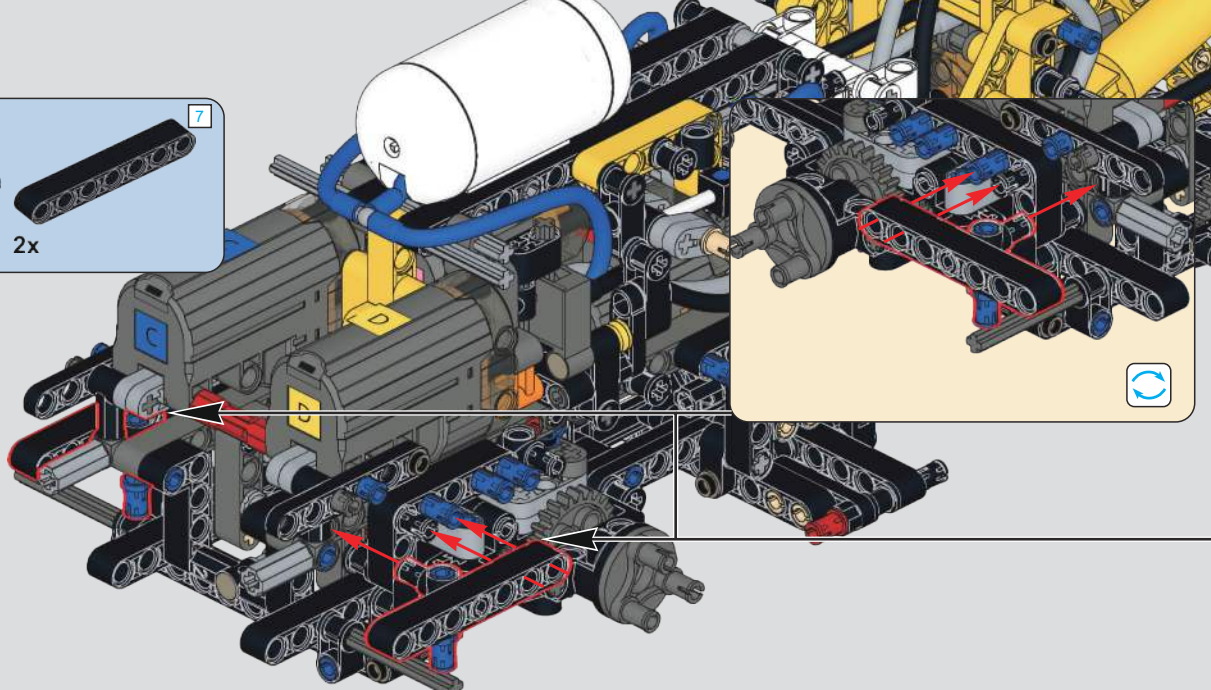

161

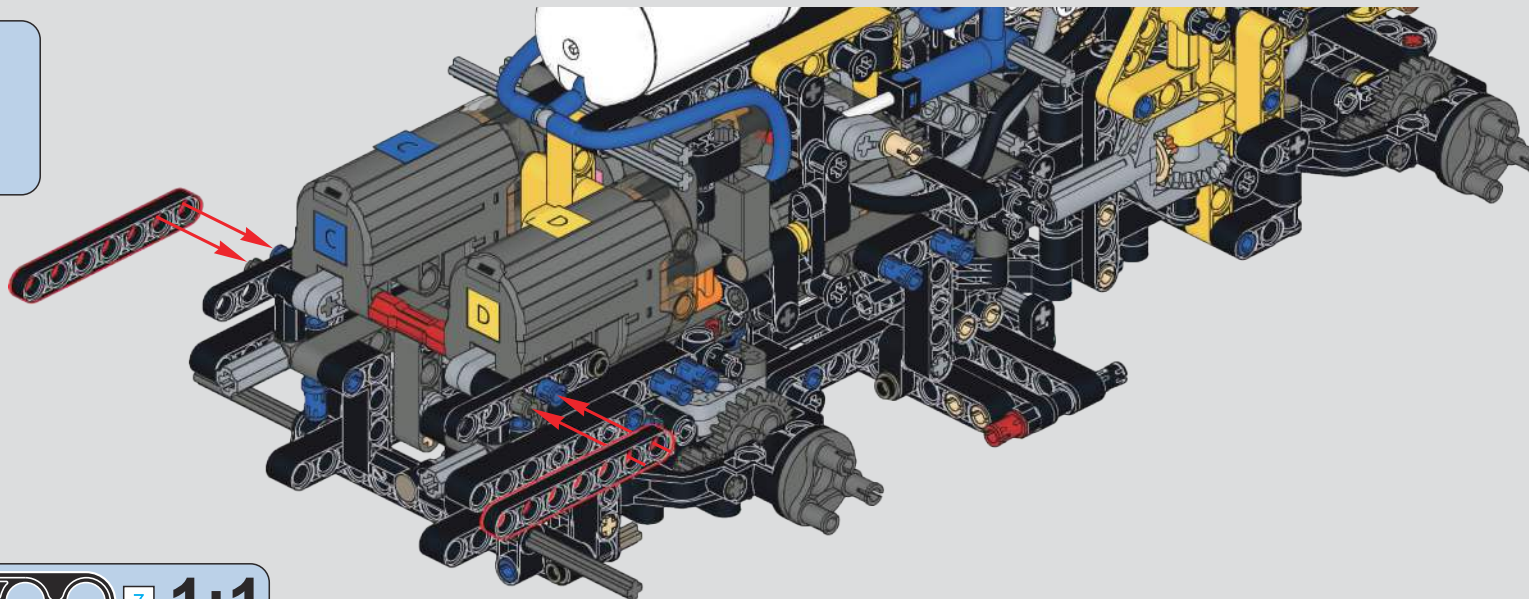

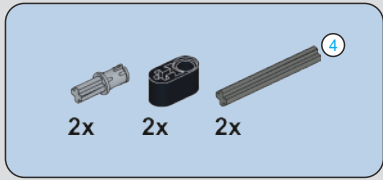

162

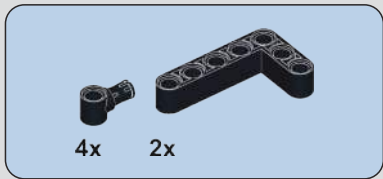
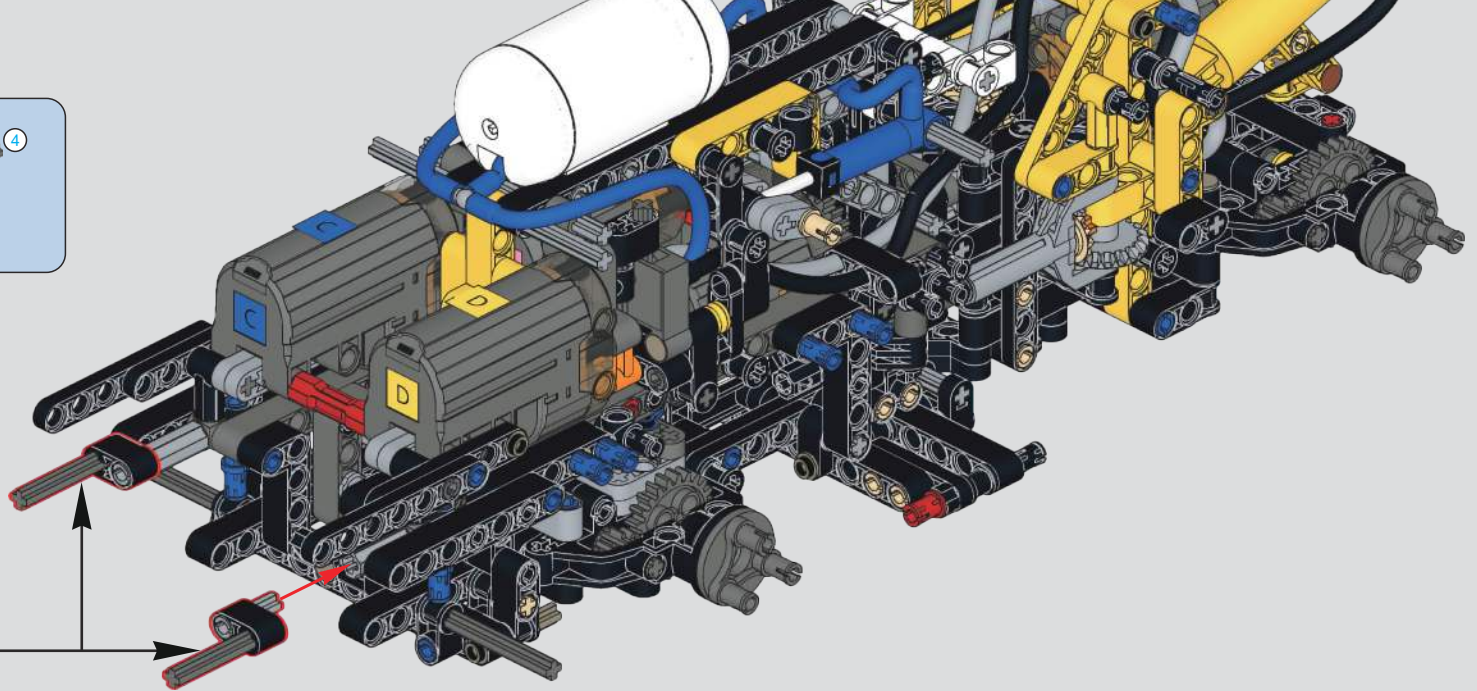
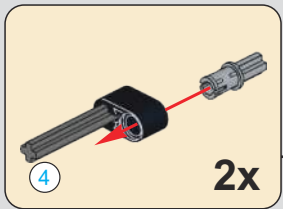

163

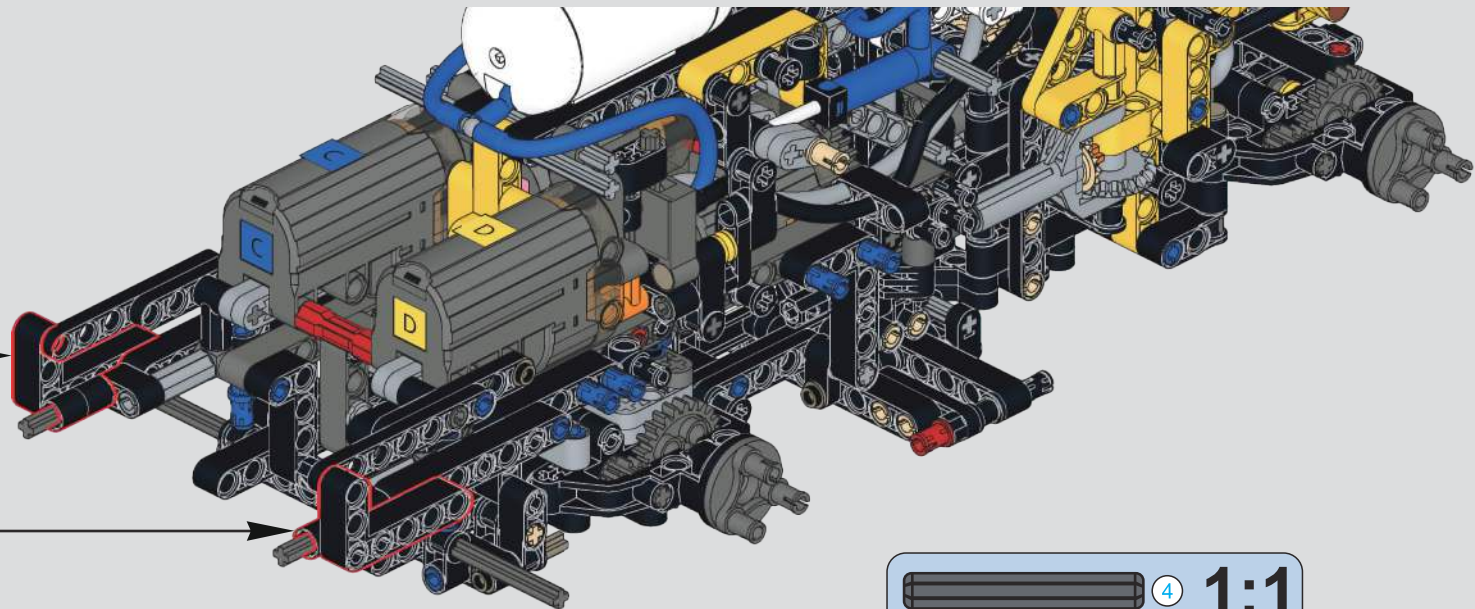
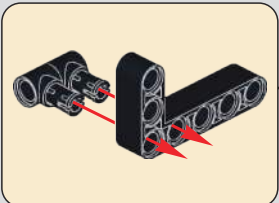
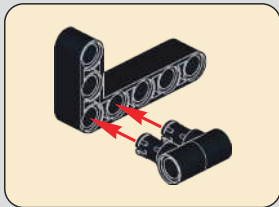



165

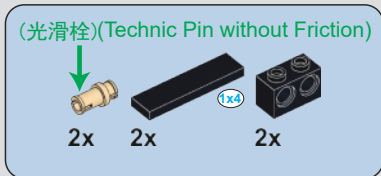
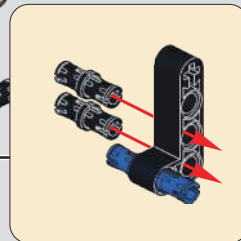
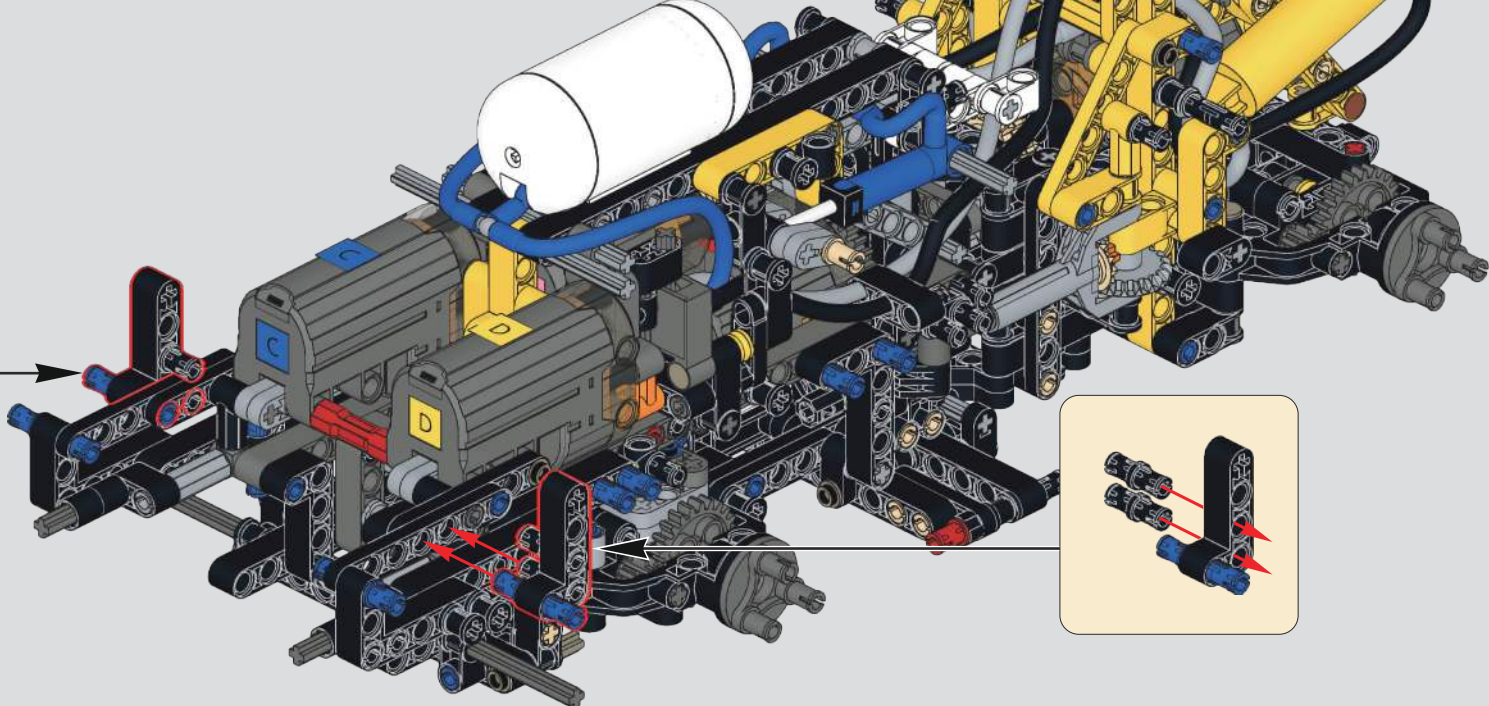
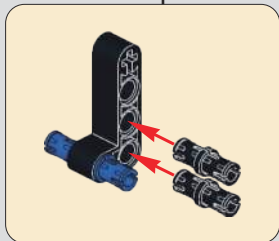

166

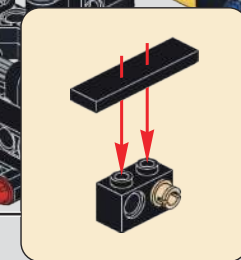
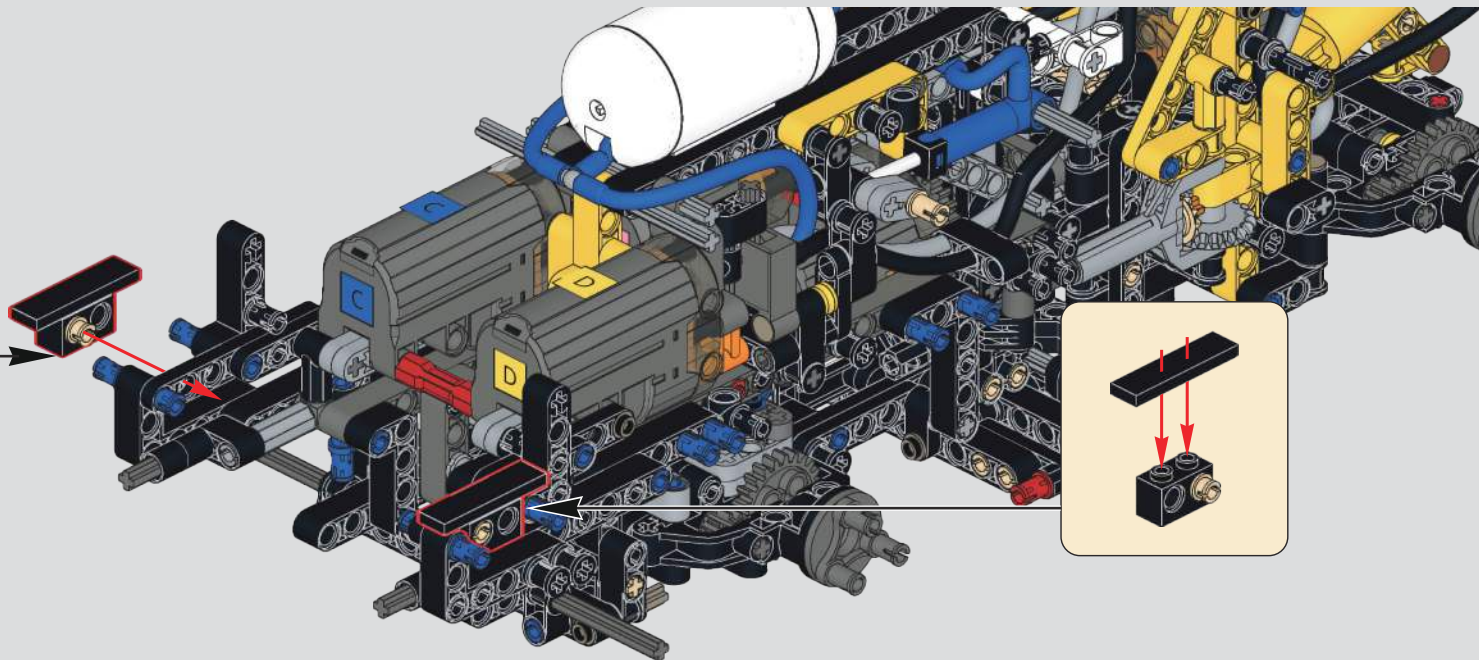
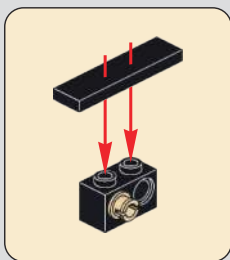

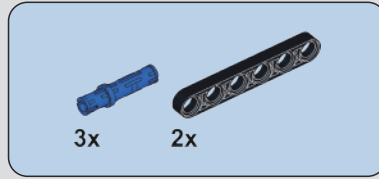
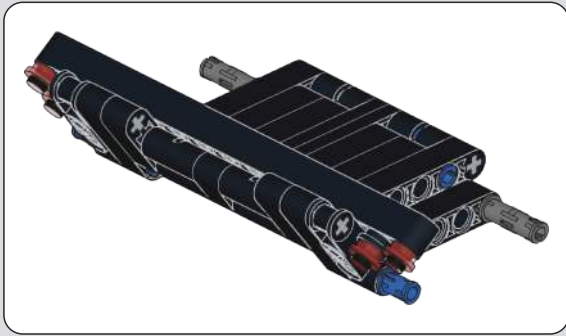

167



168

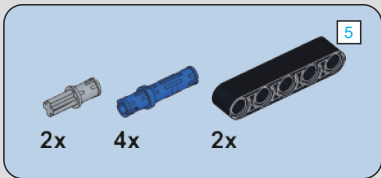
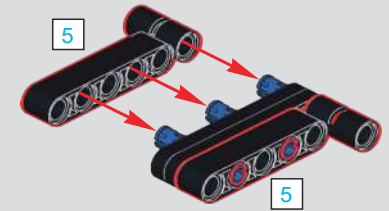
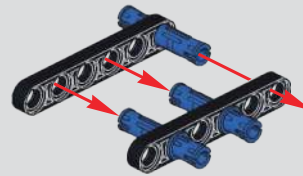

169

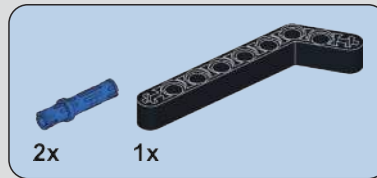

170

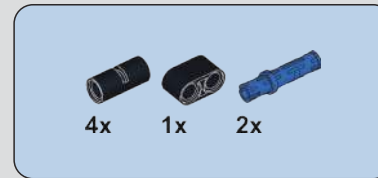

171

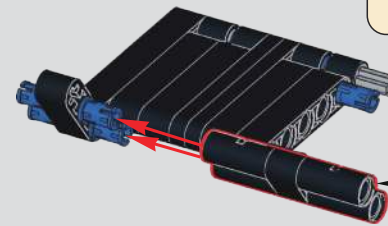
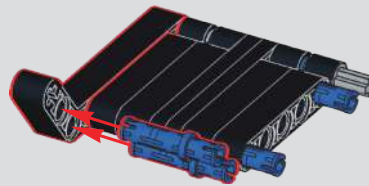
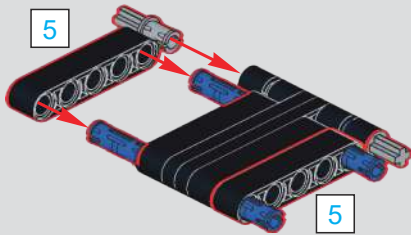
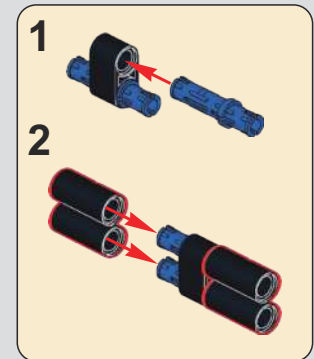

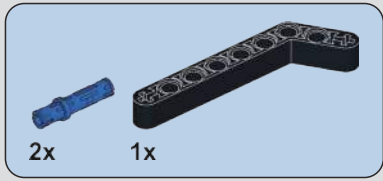

172

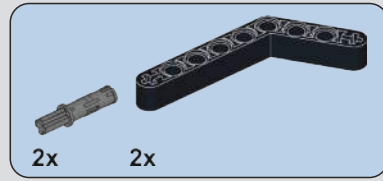
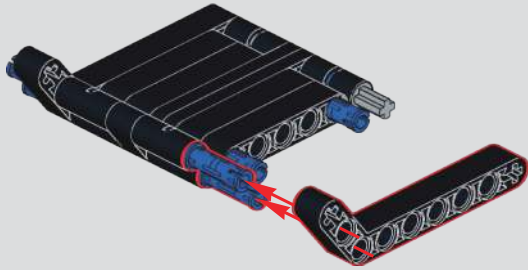

173

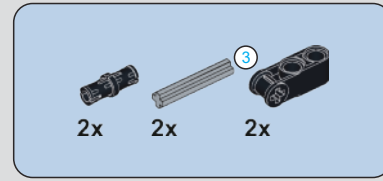
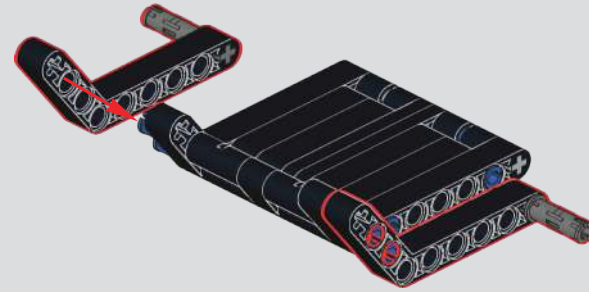

174

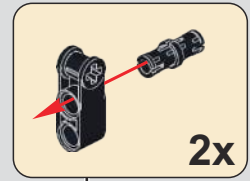
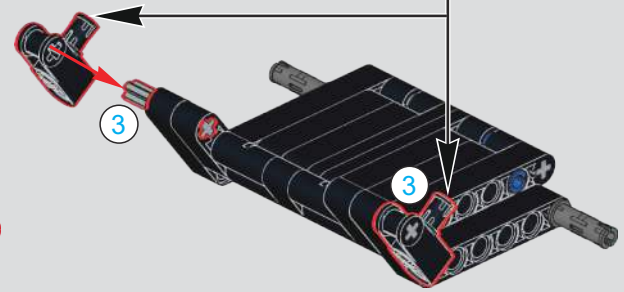

2x



175

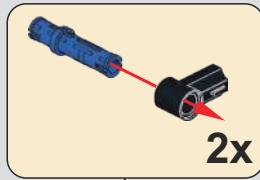
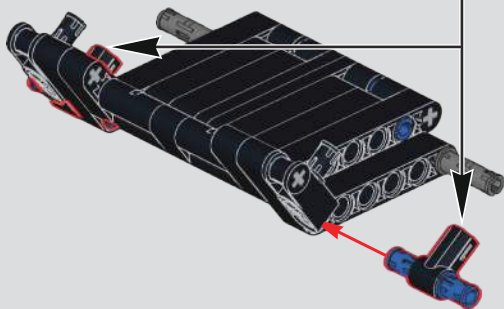

2x

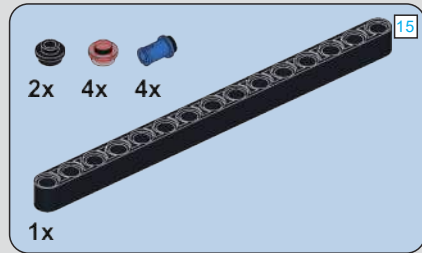

176

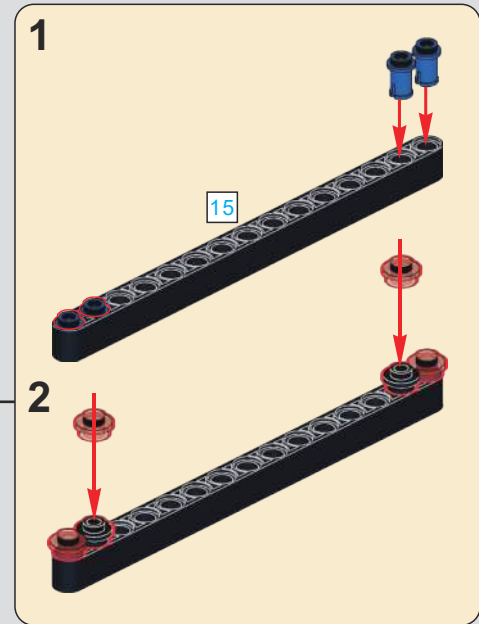
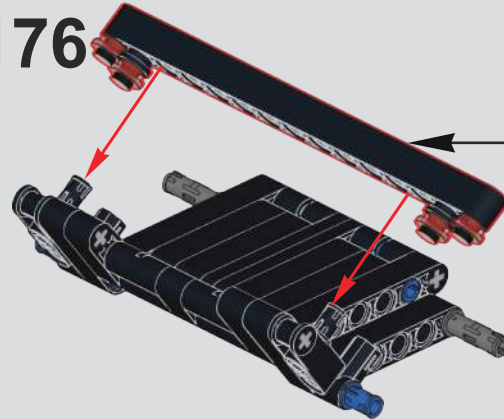

177

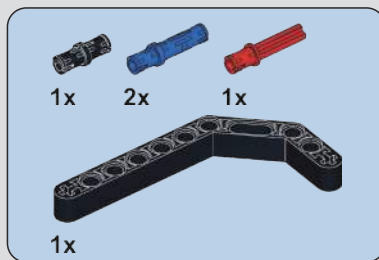
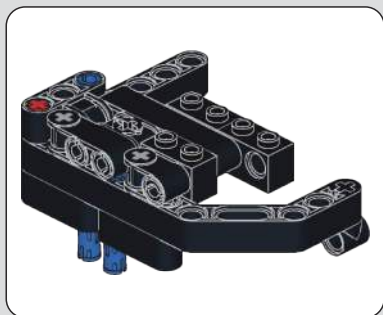
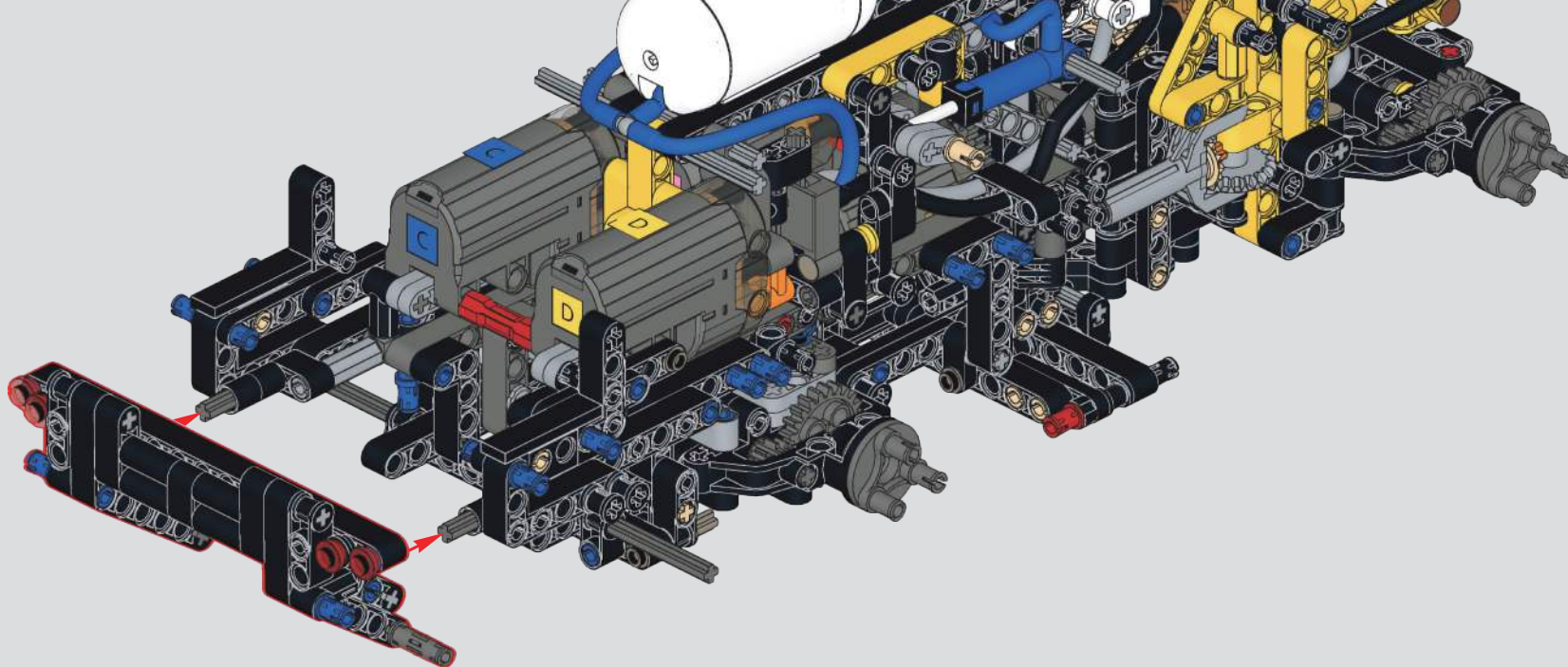

178

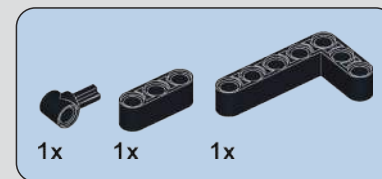
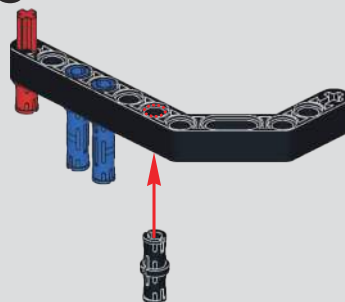

179

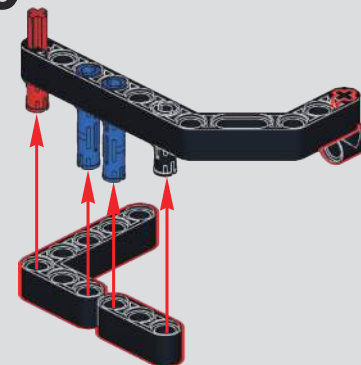

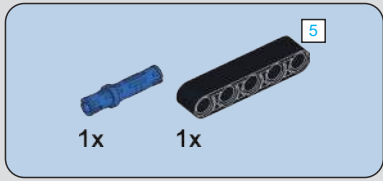

180

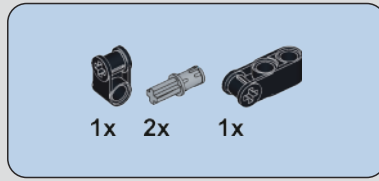
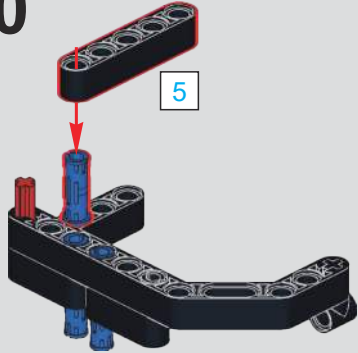

181

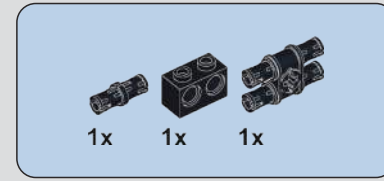
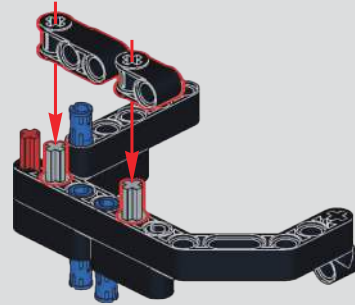

182

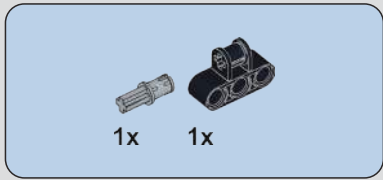
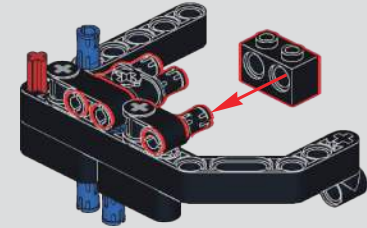

183

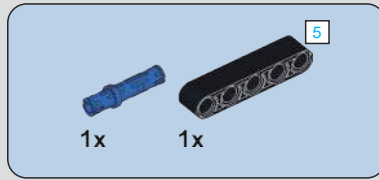
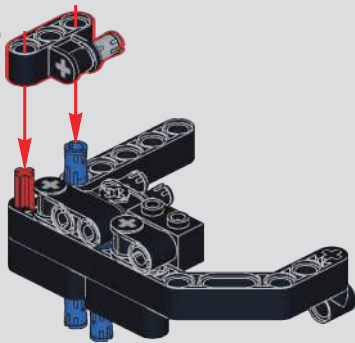

184

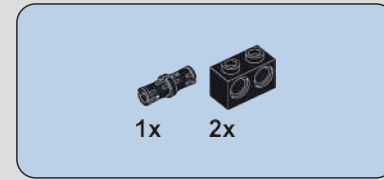
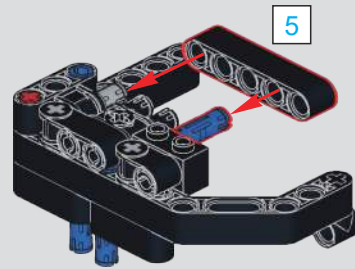

185

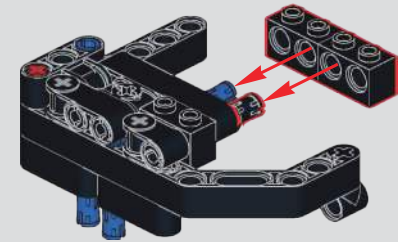

186

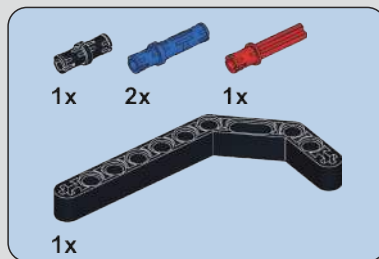
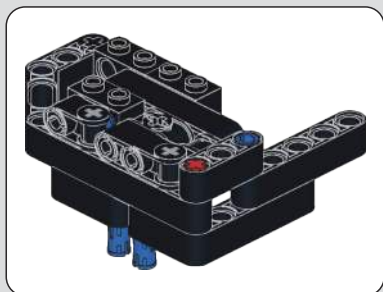
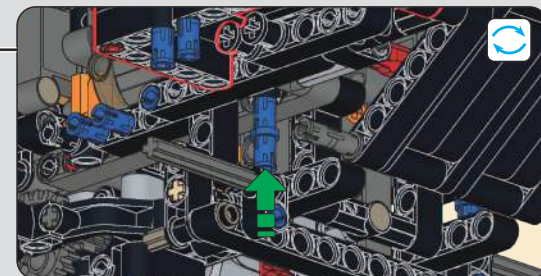
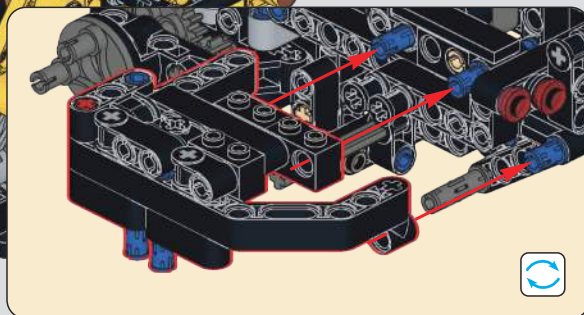
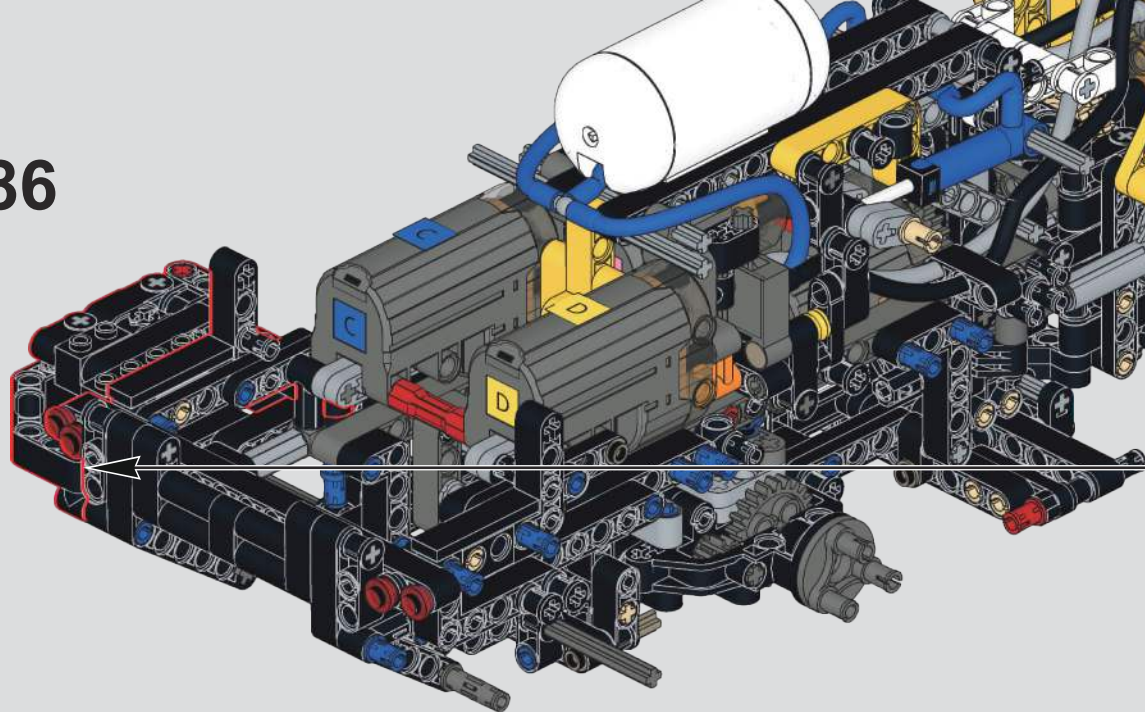

187

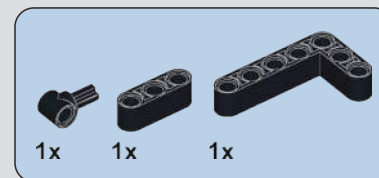
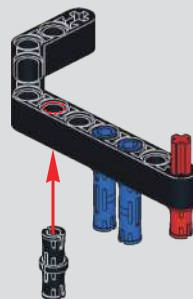

188

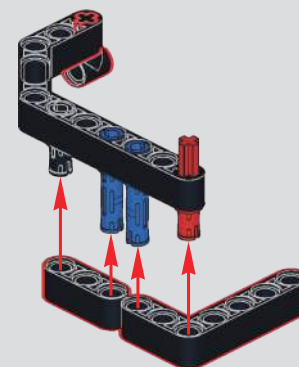

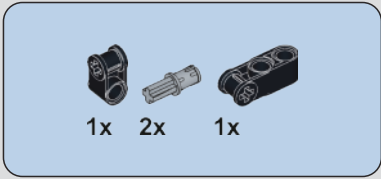

189

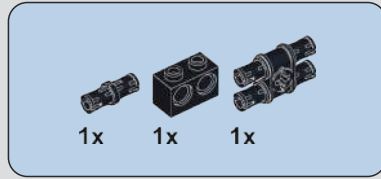
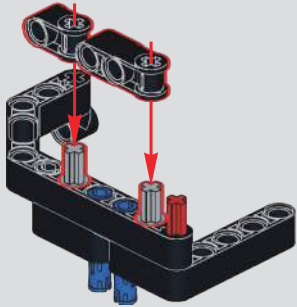

190

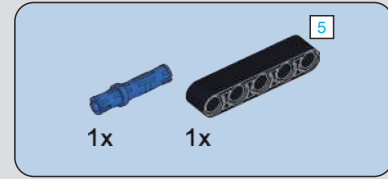
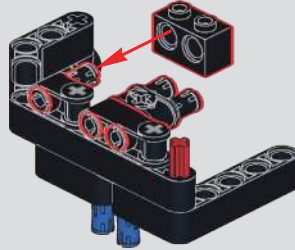

191

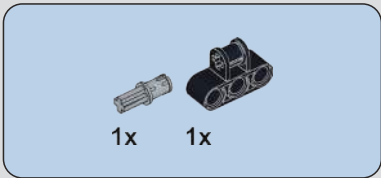
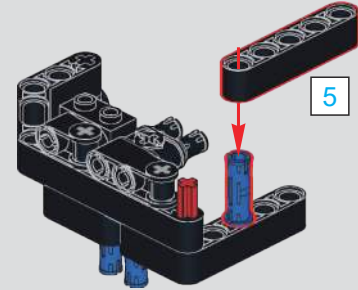

192

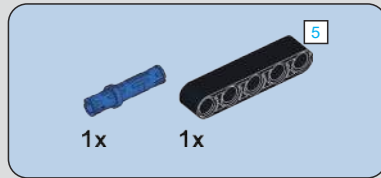
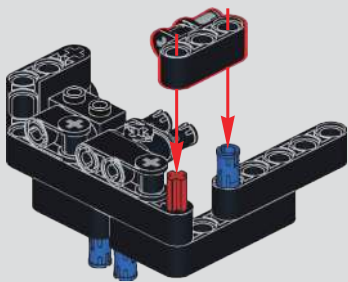

193

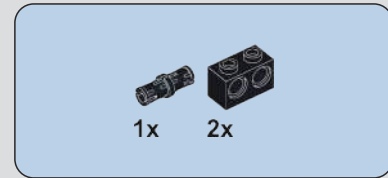
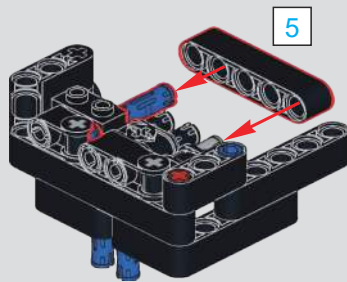

194

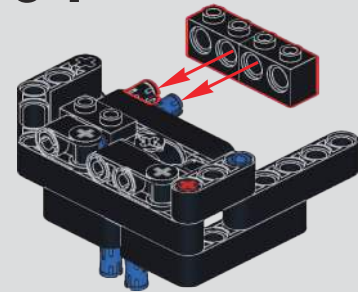

195

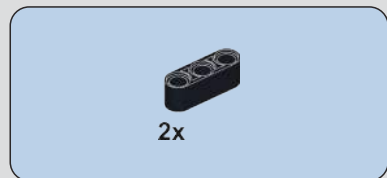
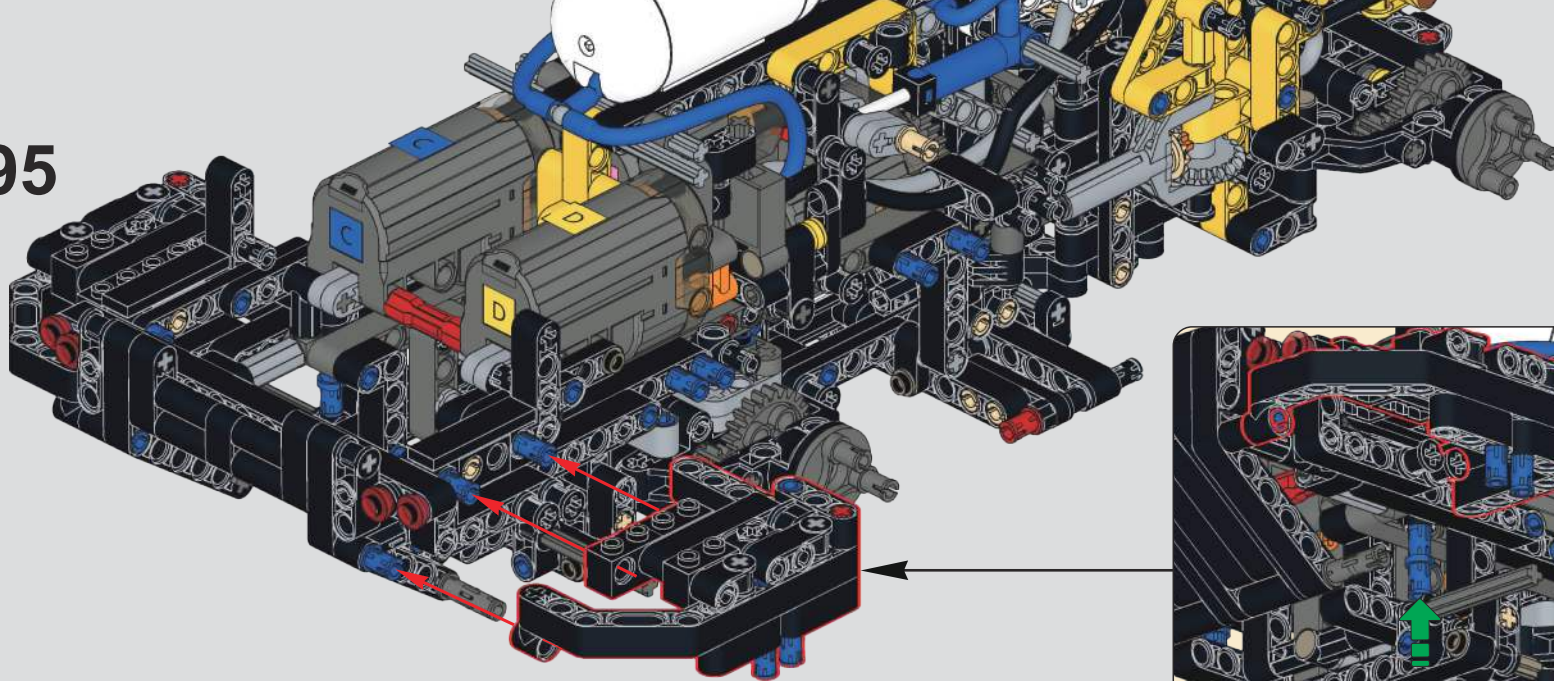

196

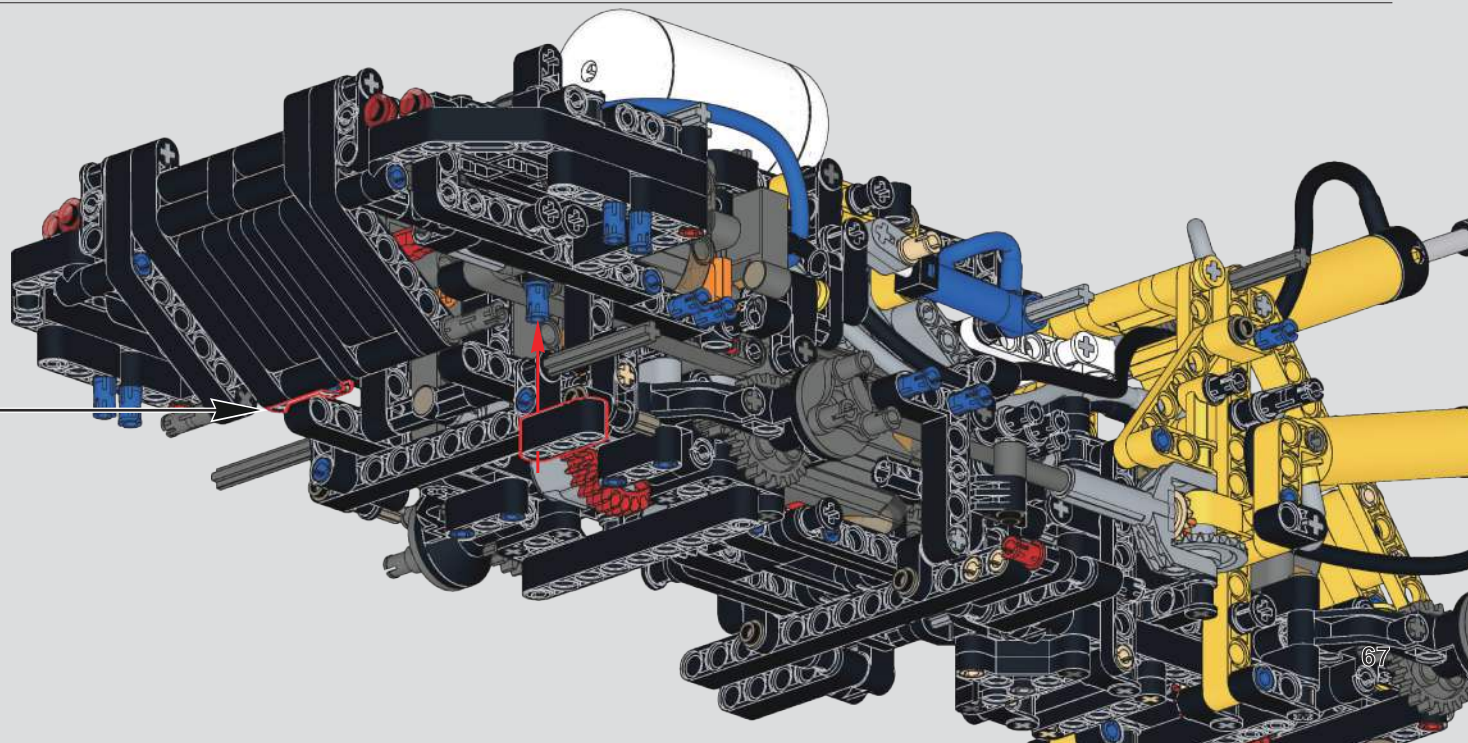
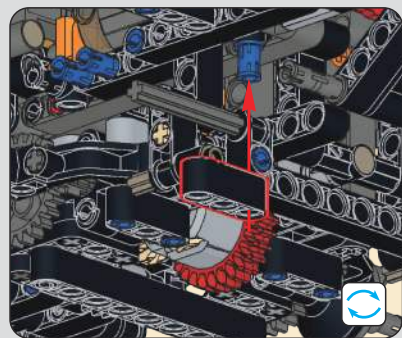

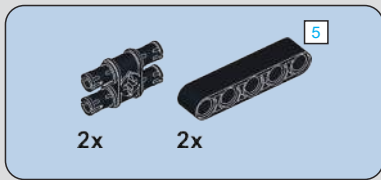

197

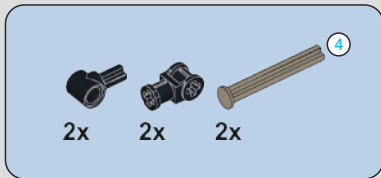
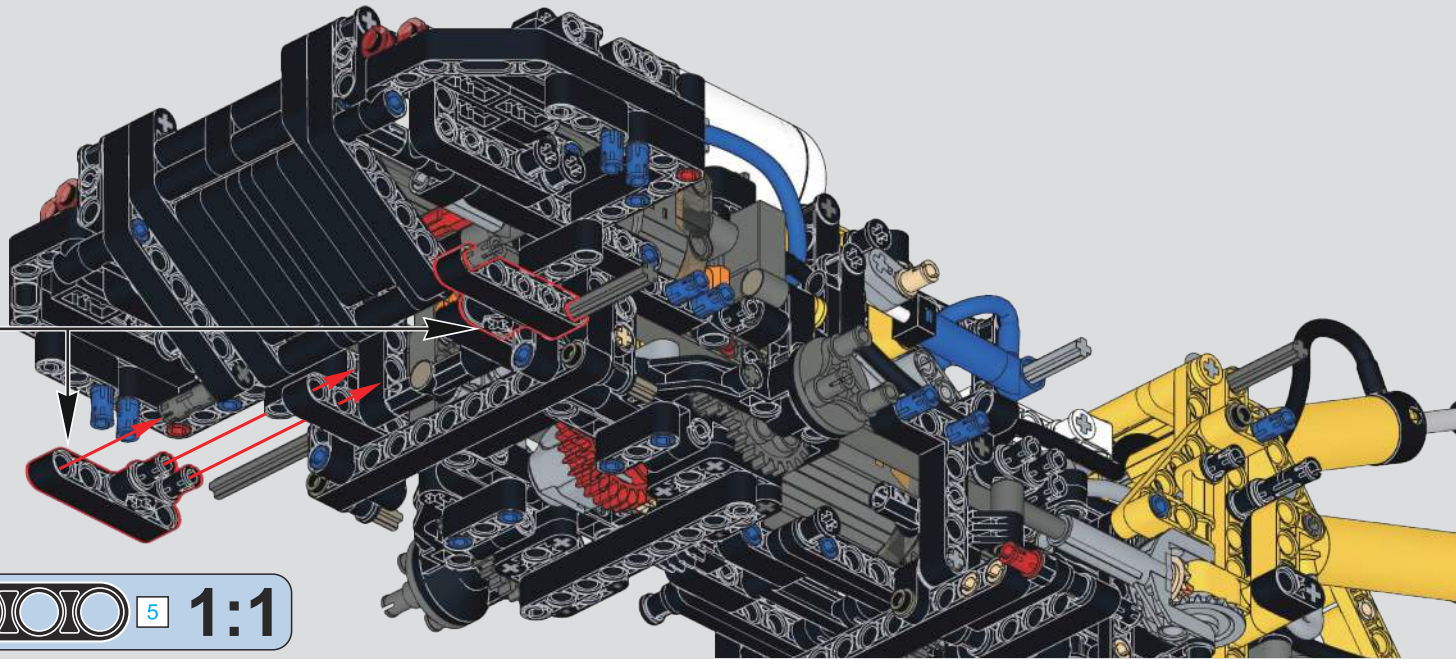
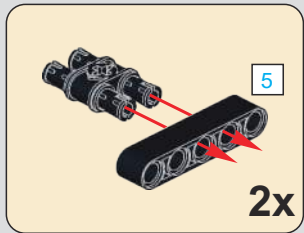

198

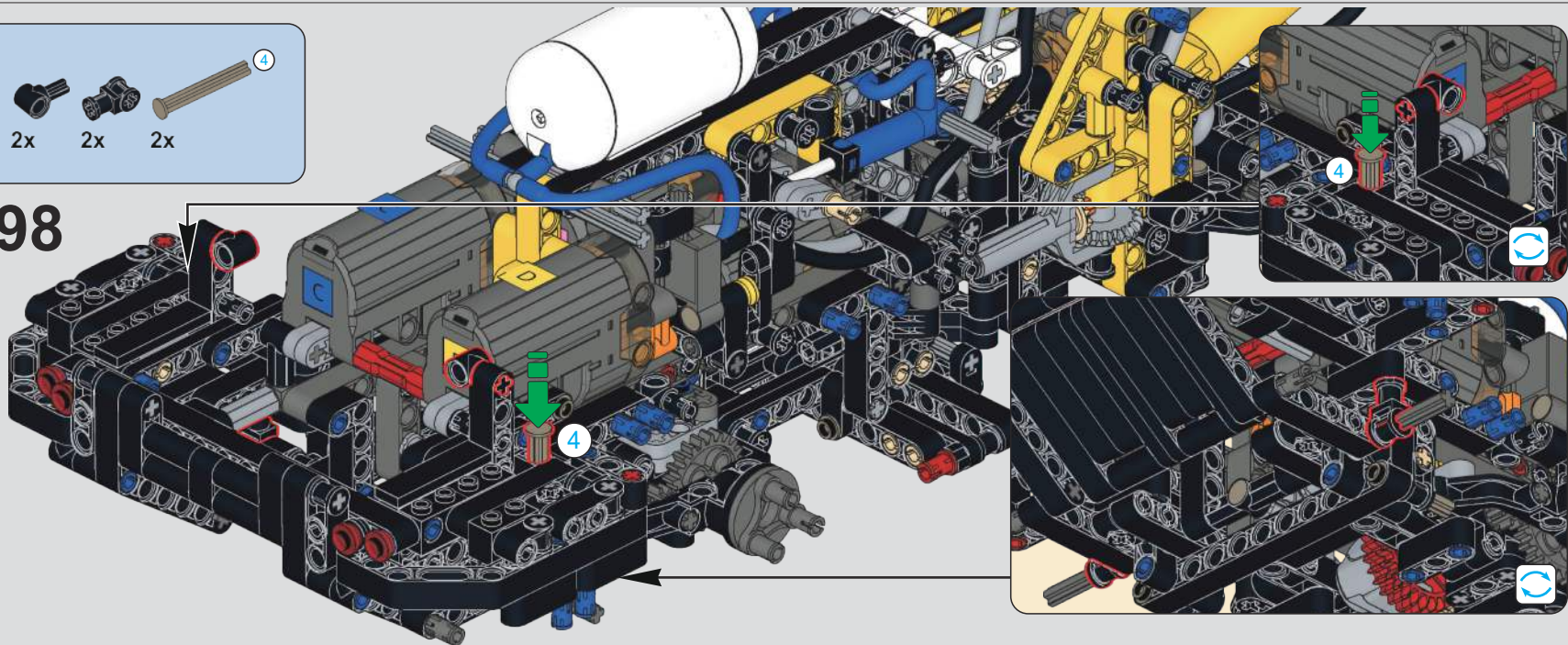

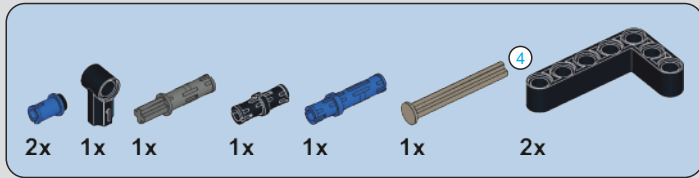

199

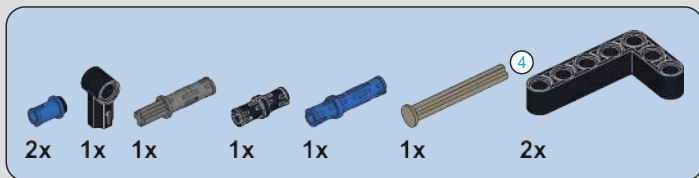
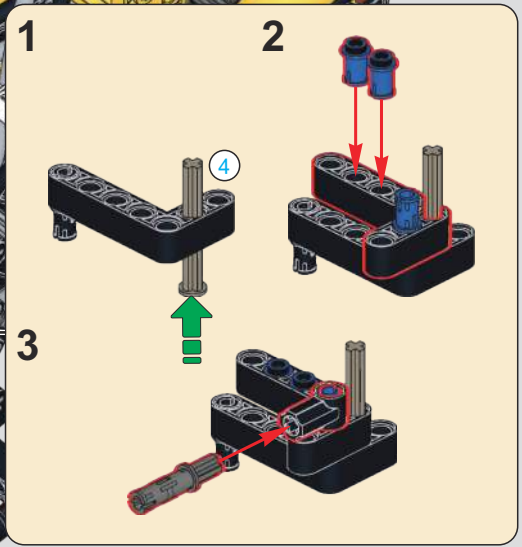
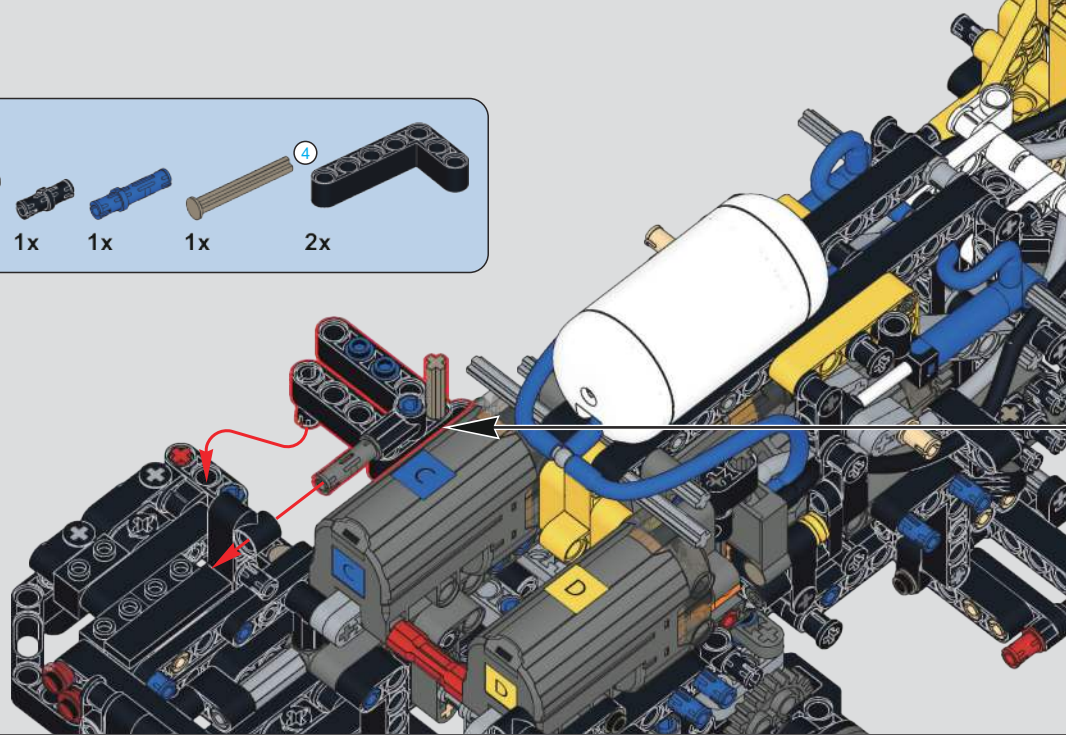

200

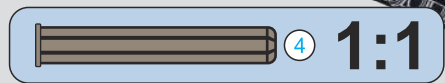
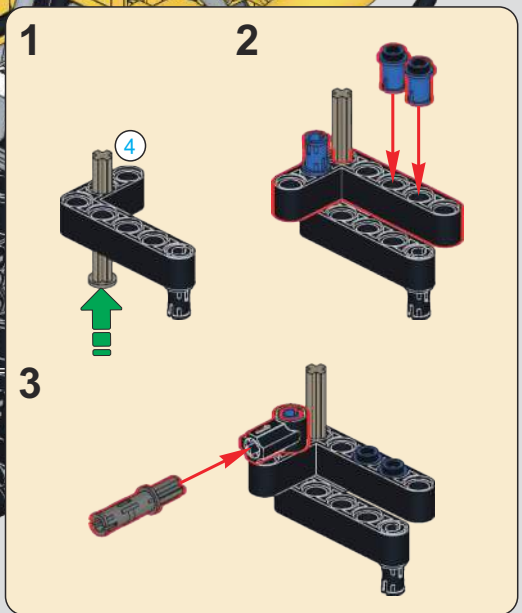
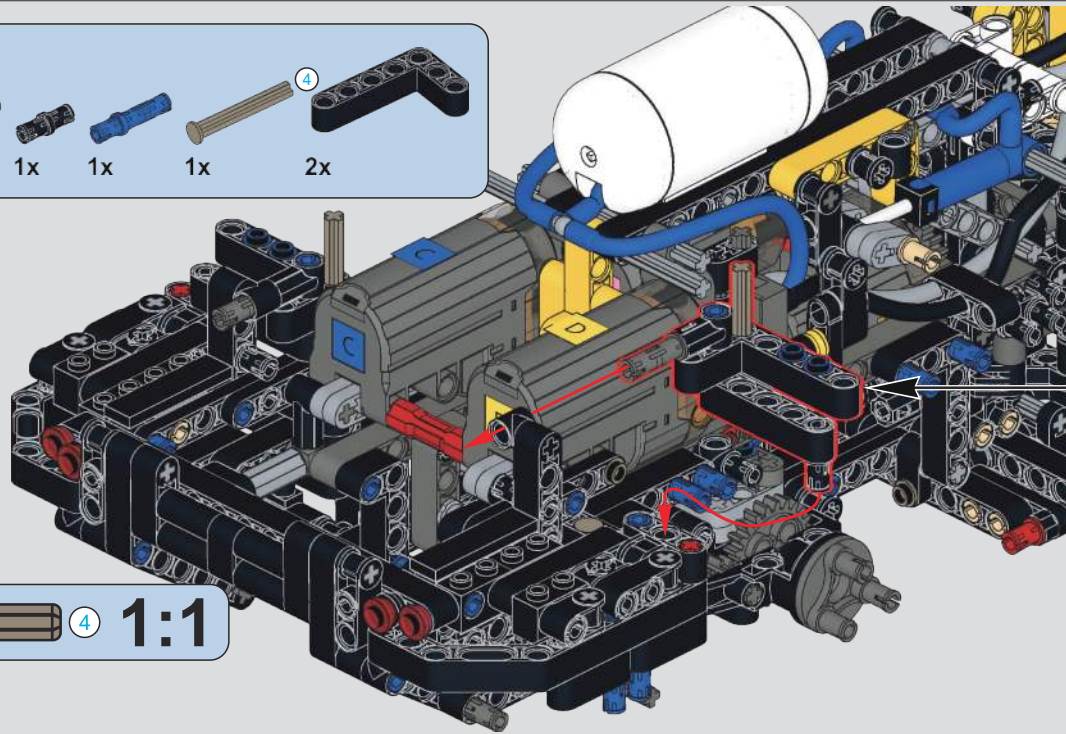

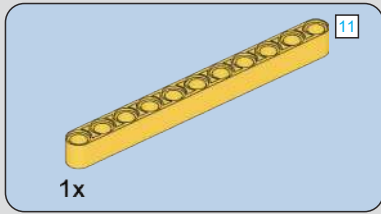

201

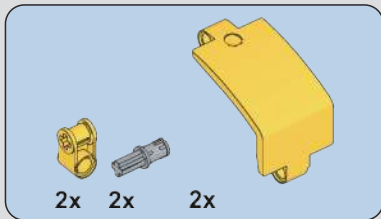
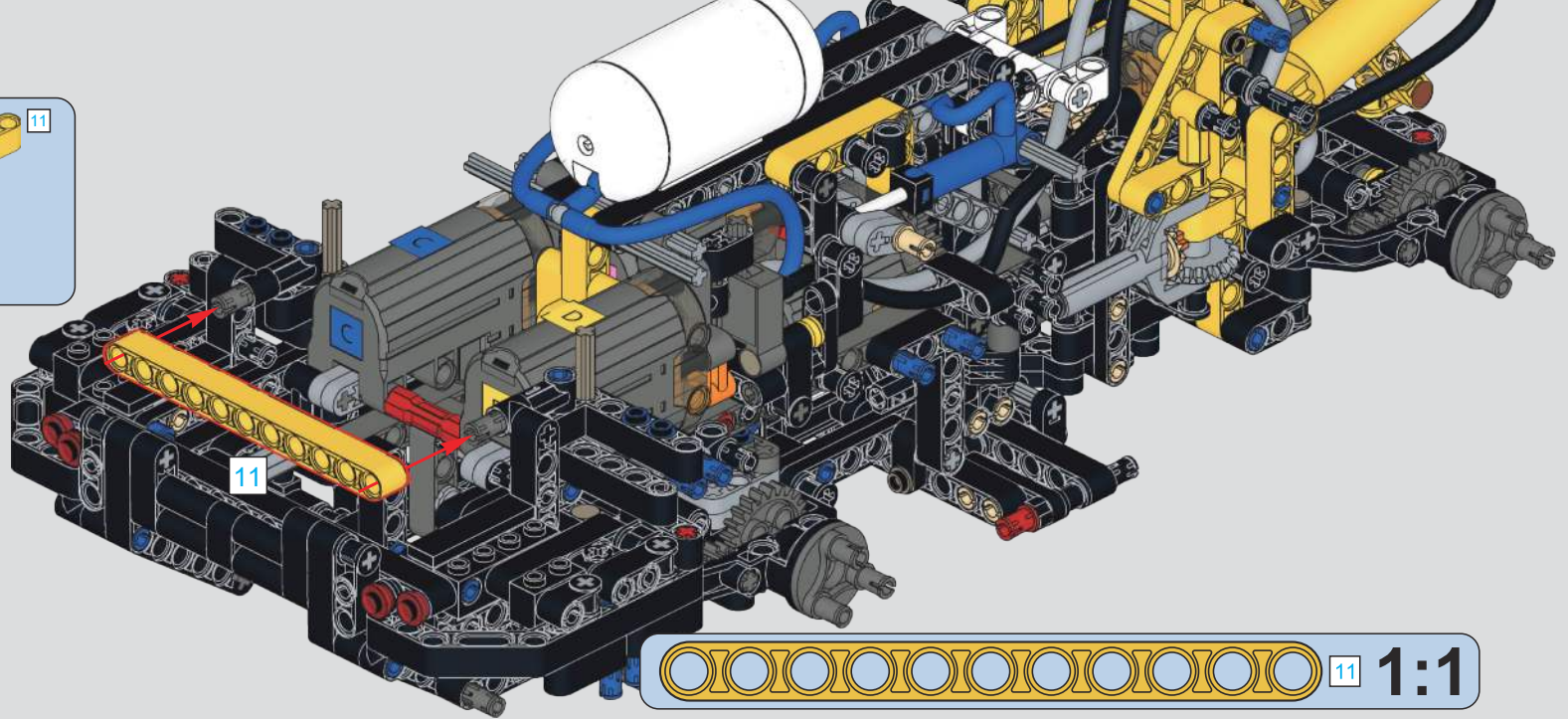

202

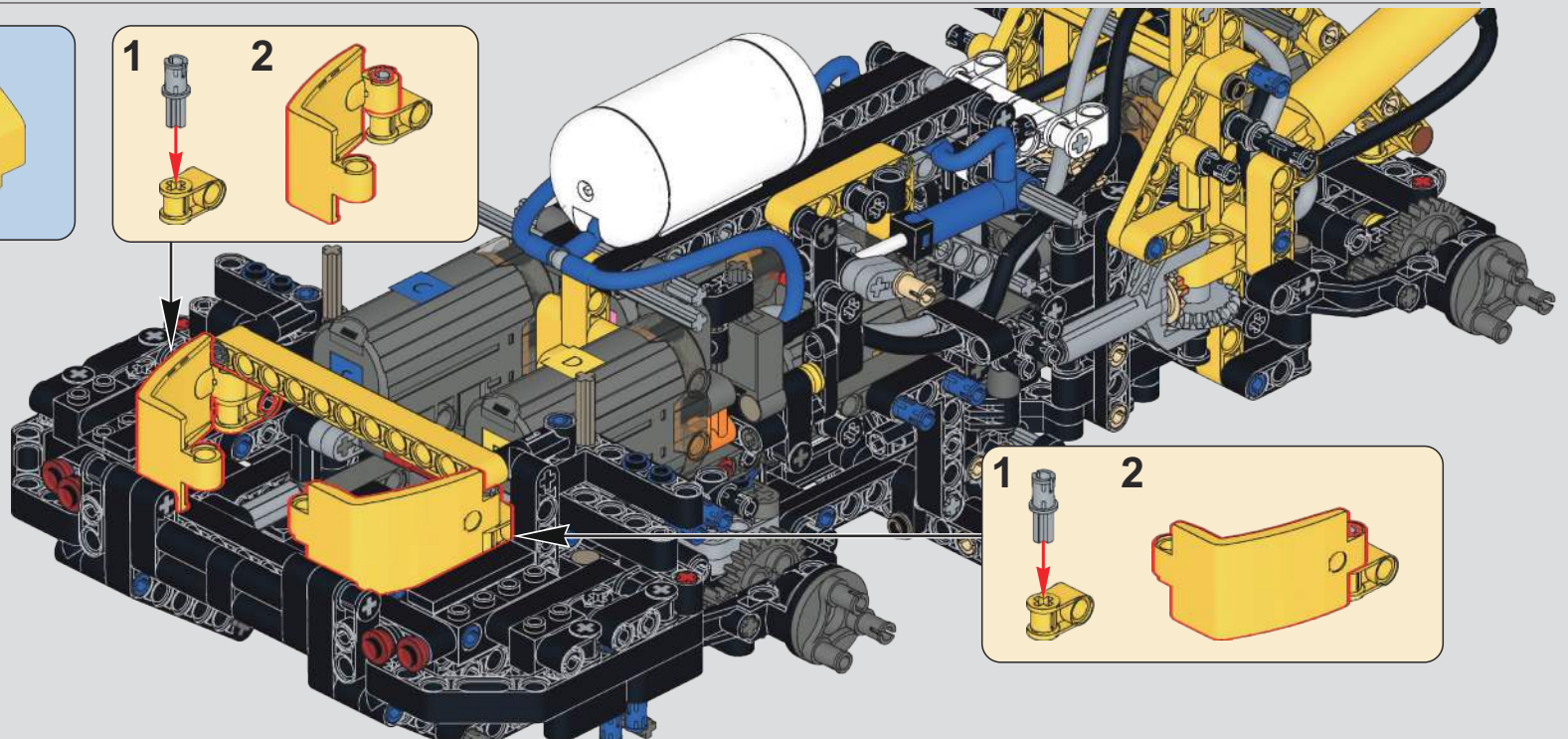

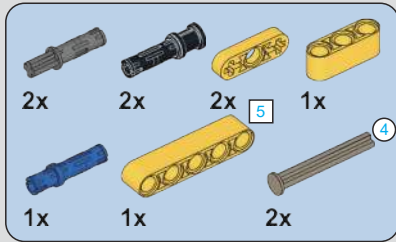

203

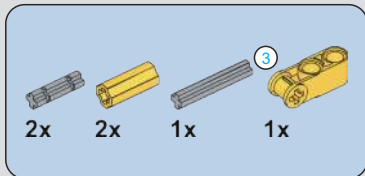
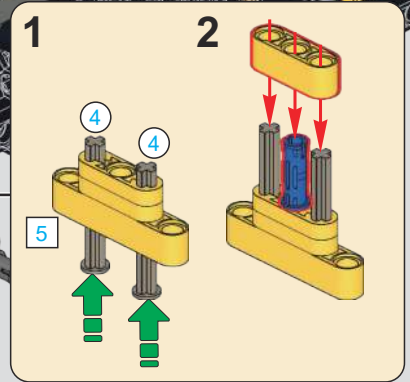
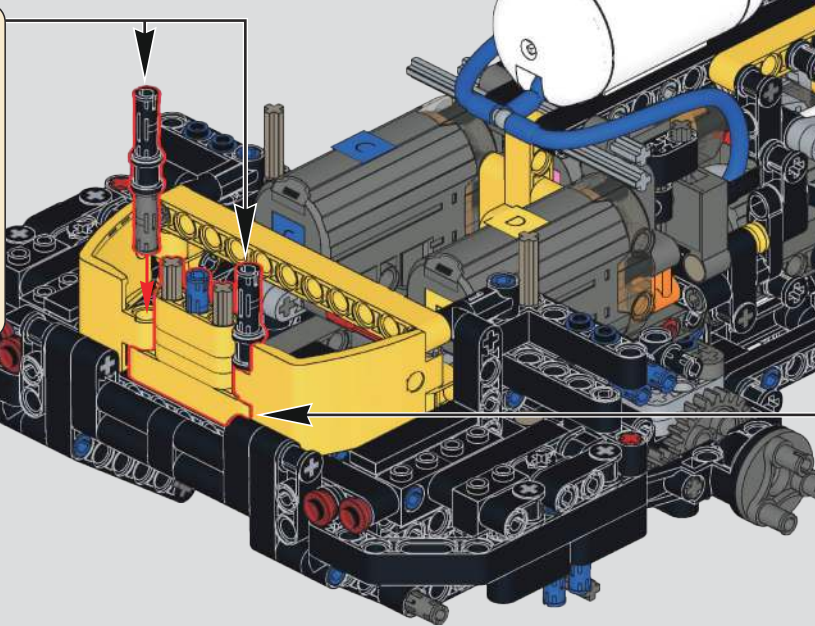
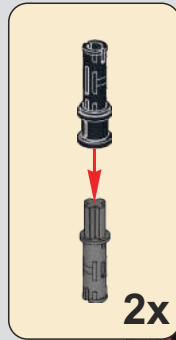

204

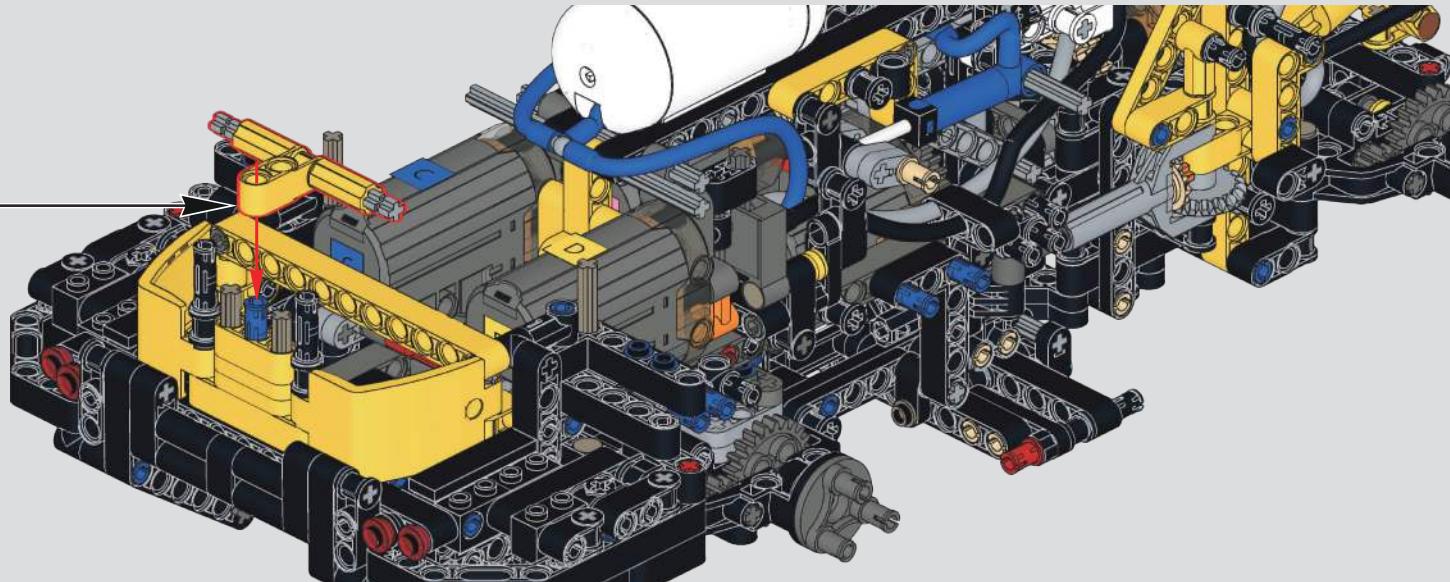
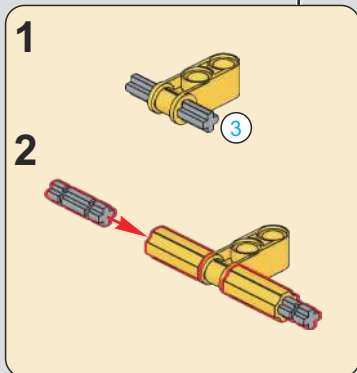

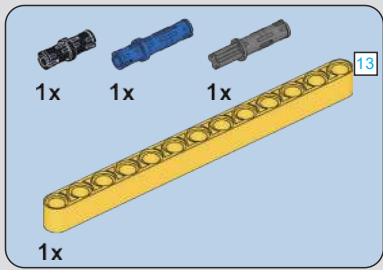

205

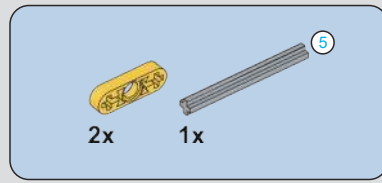
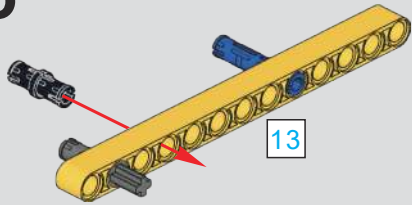

206

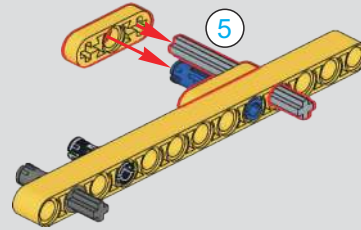

207

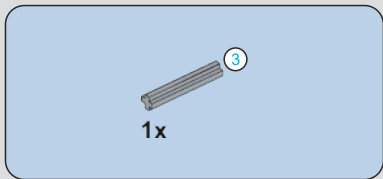
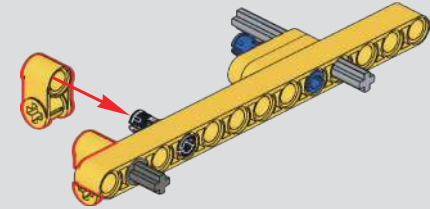

208

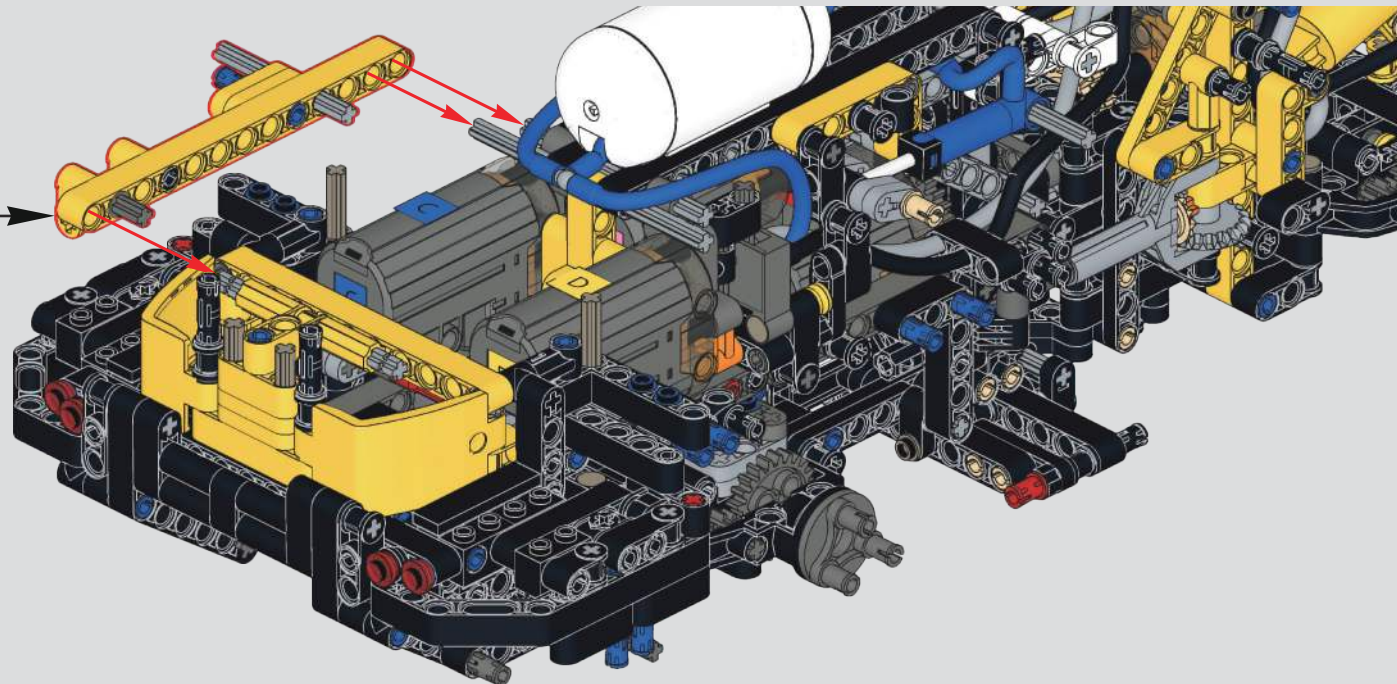
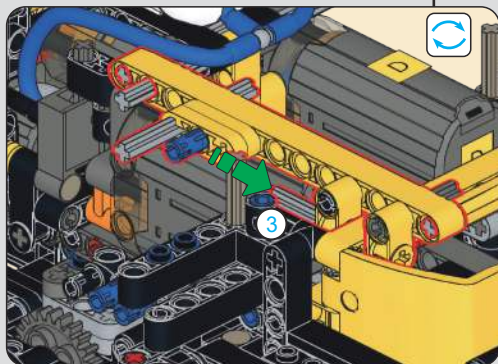

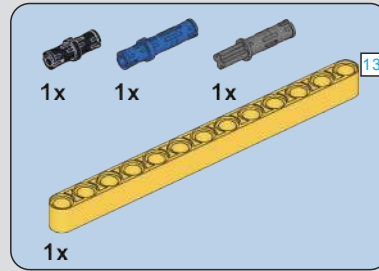
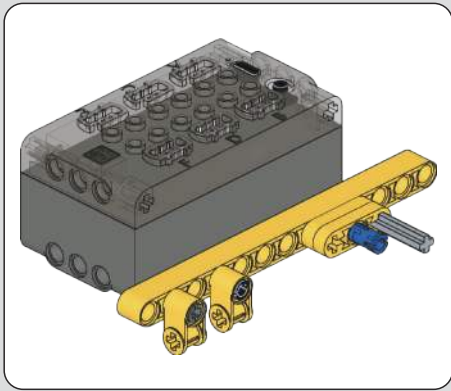

209

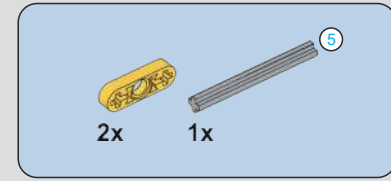
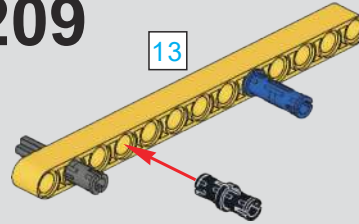

210

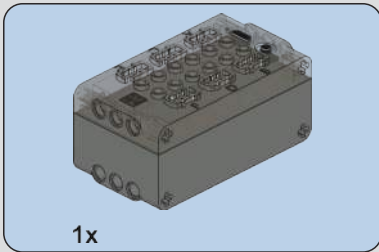
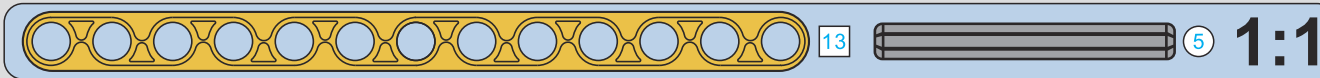
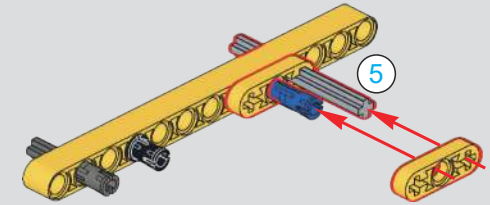

211

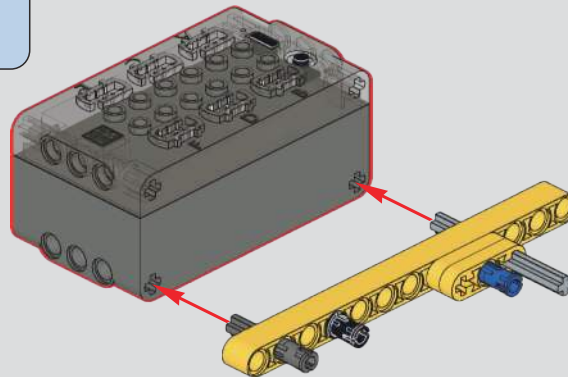

212

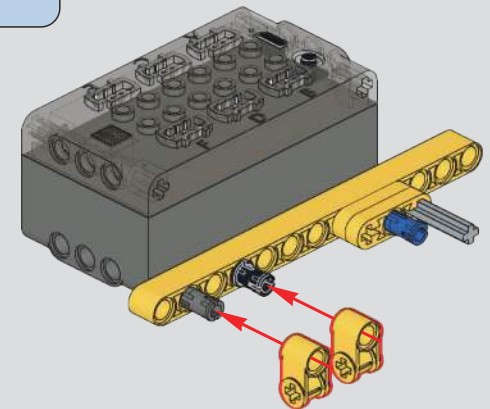

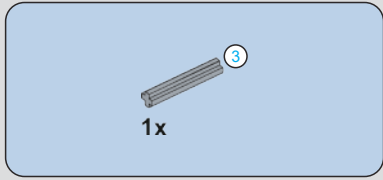

213

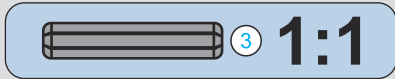
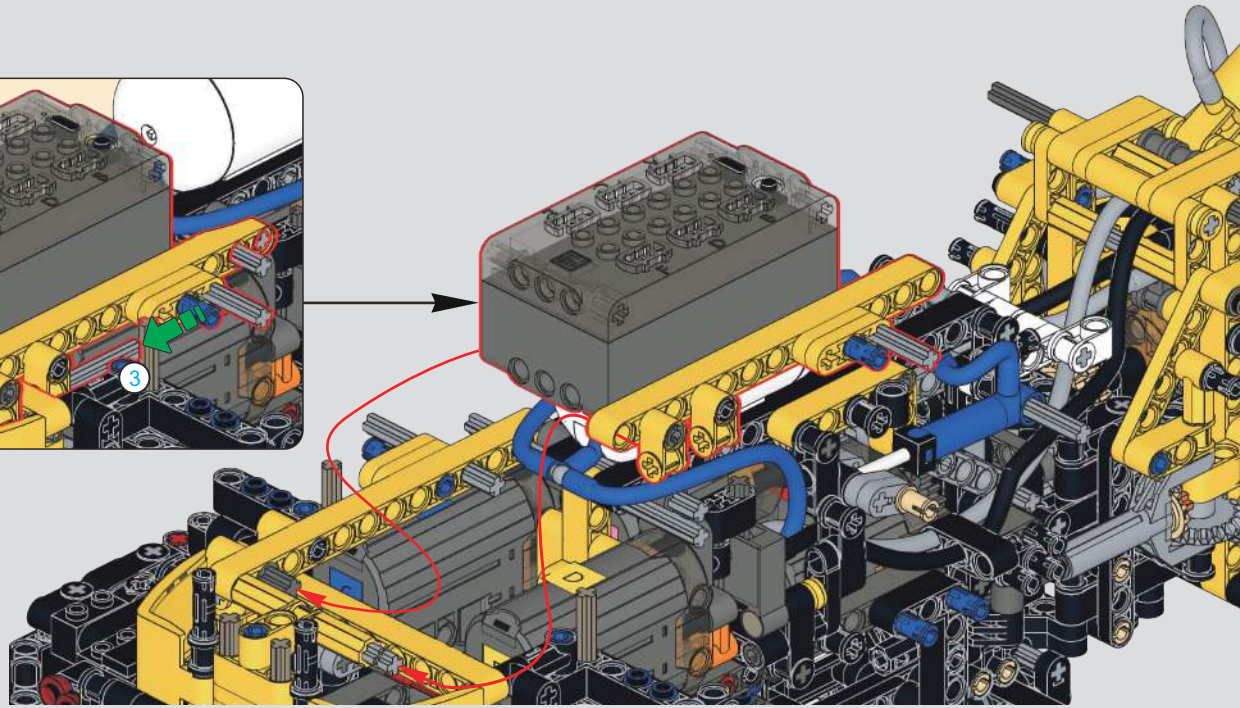
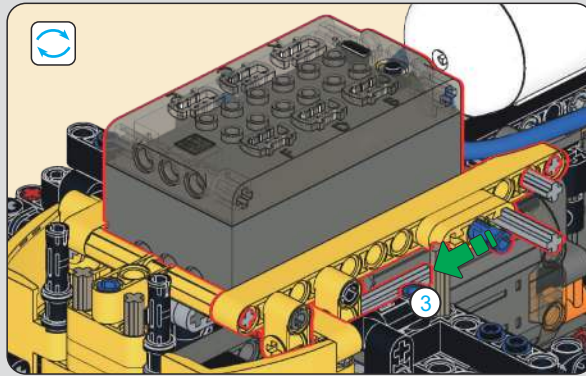

214

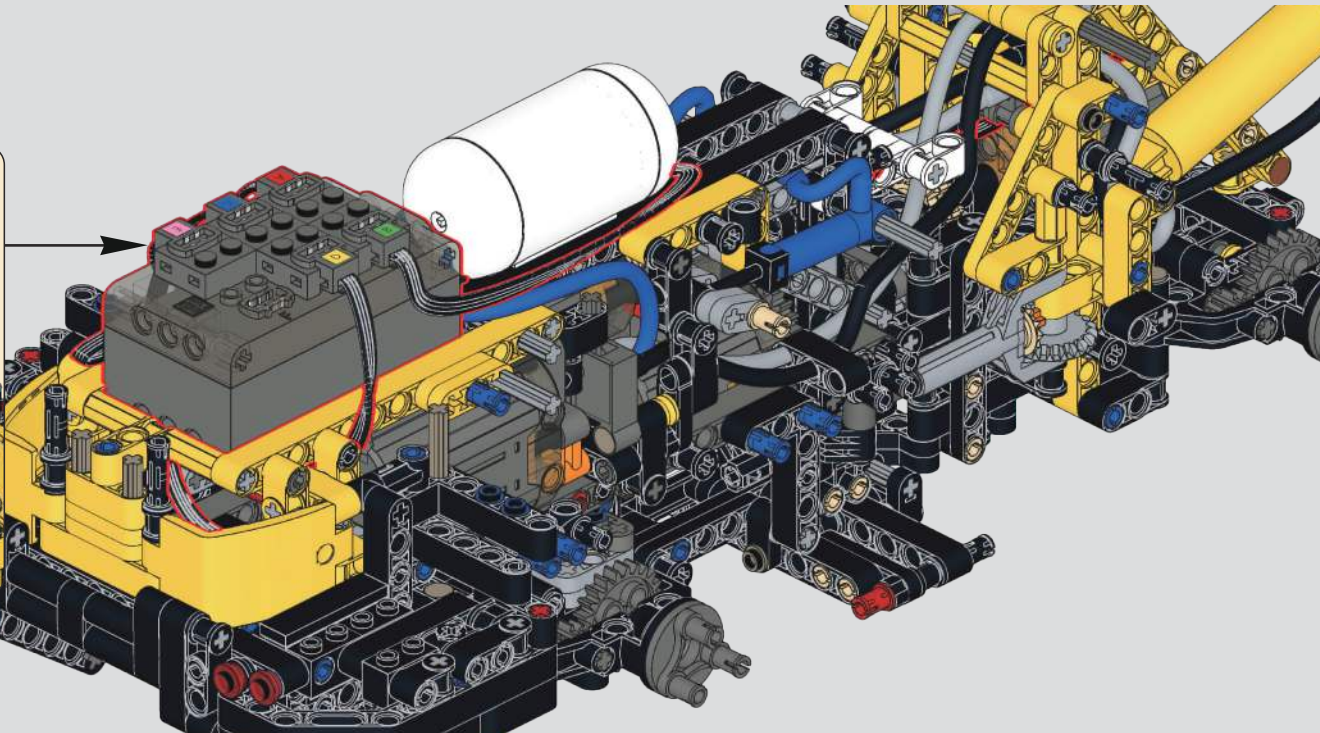
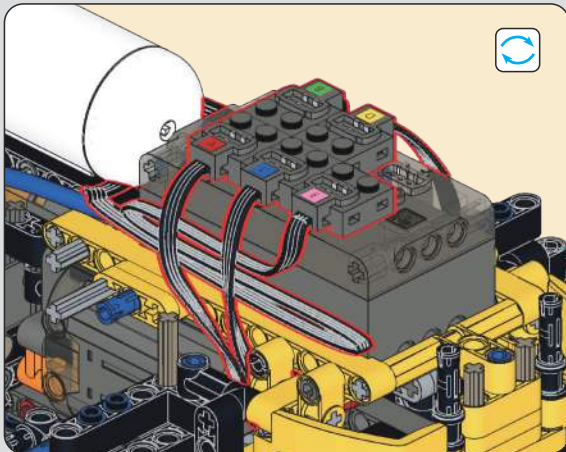

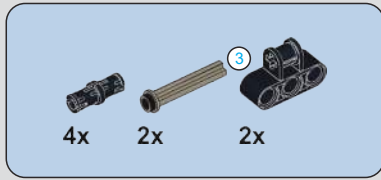

215

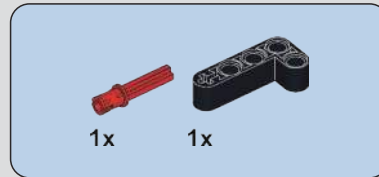
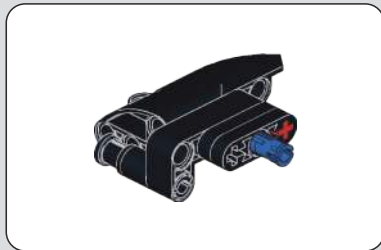
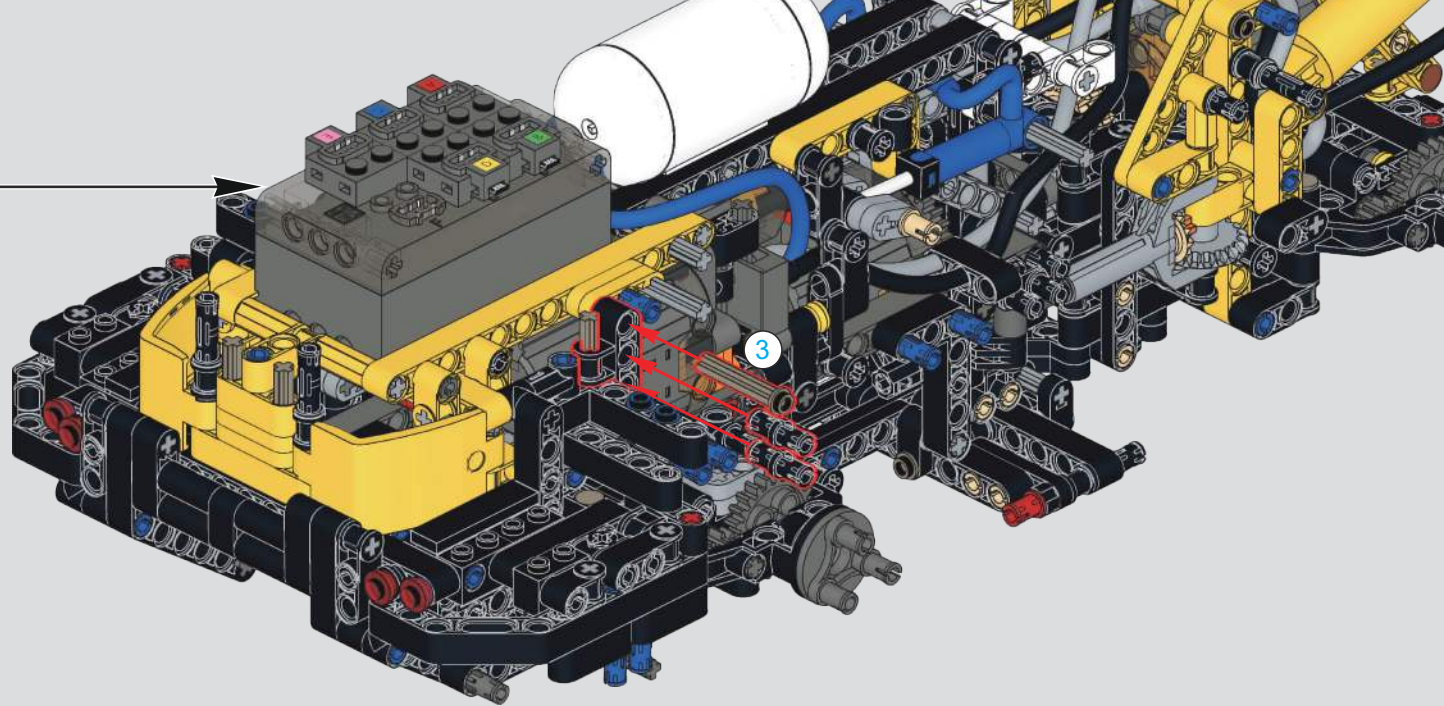
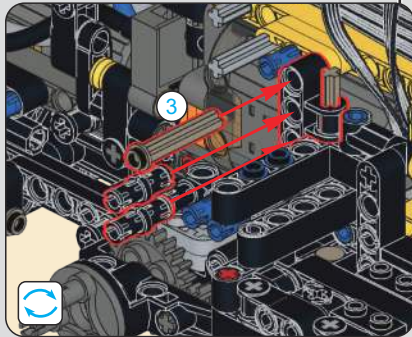

216

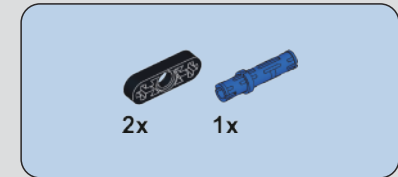
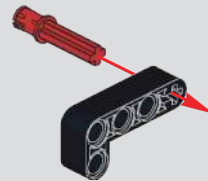

217

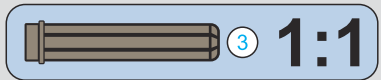
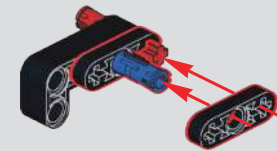



218

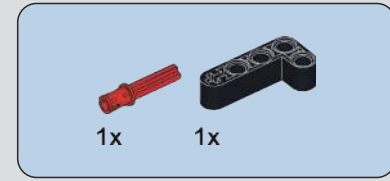
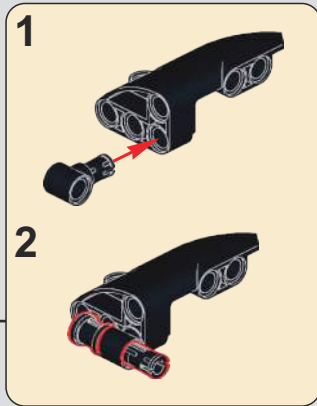
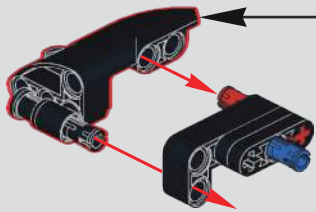

219

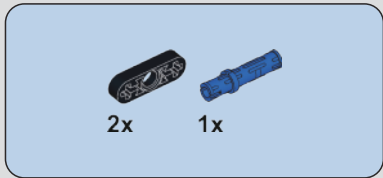
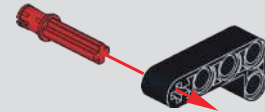

220

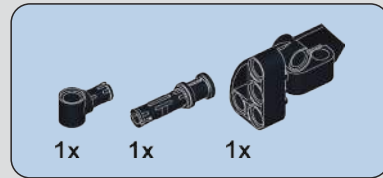
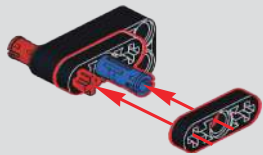

221

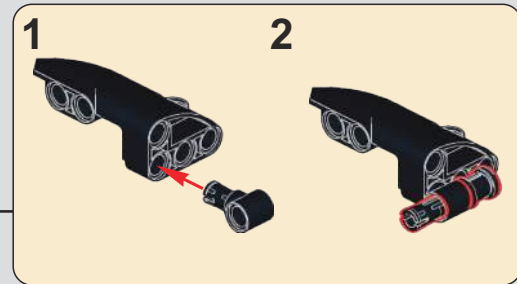
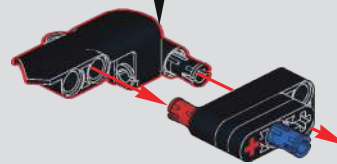

222

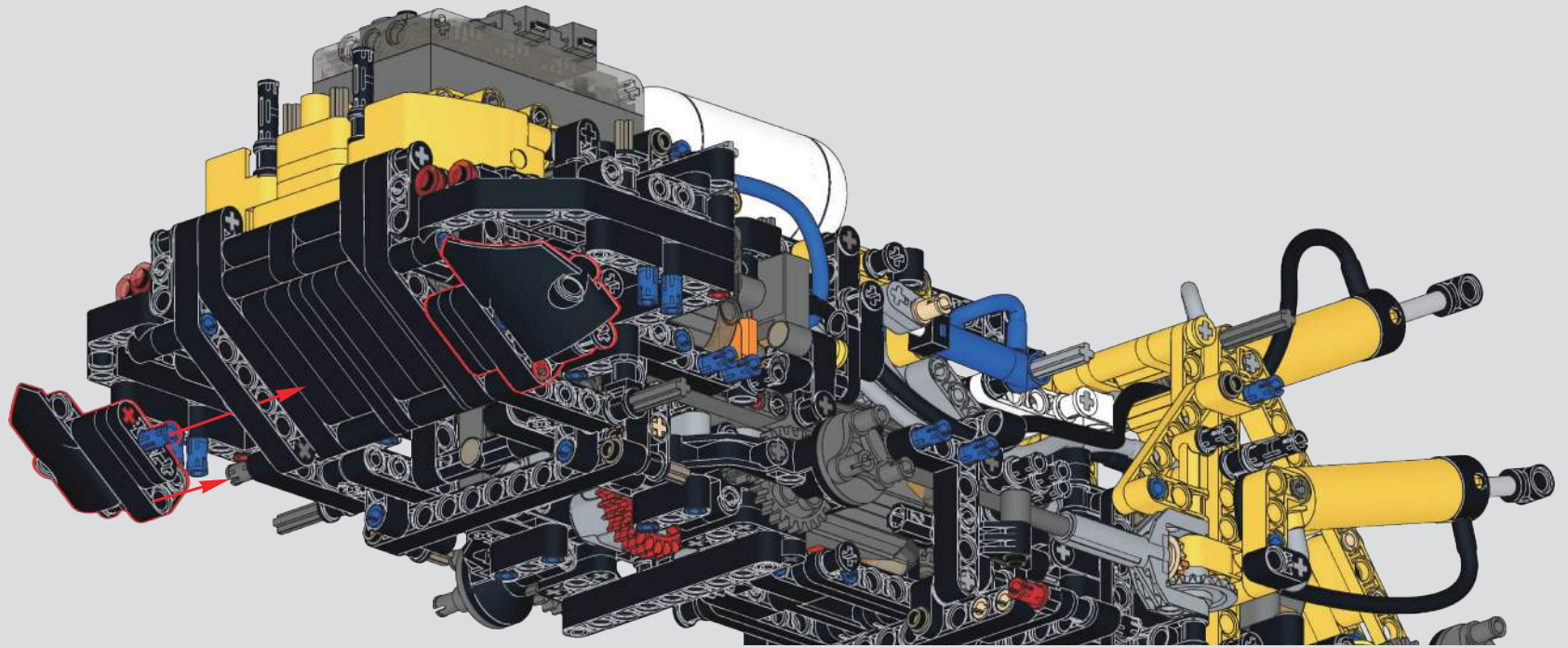

- (光滑栓)(Technic Pin without Friction)
- 1x
 - 2x
 - 2x
 - 2x

223

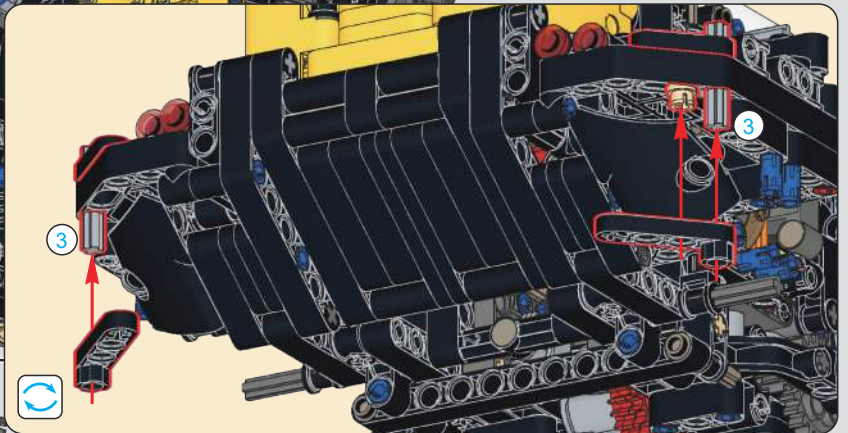
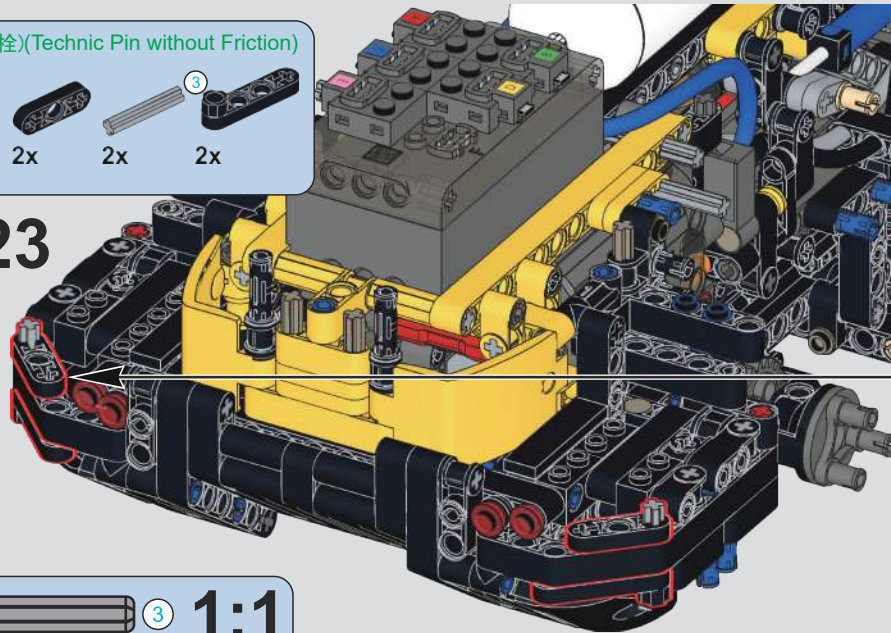

- 3 **1:1**

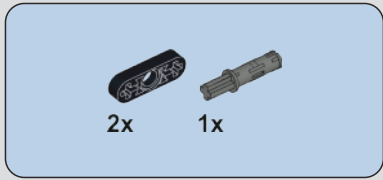

224

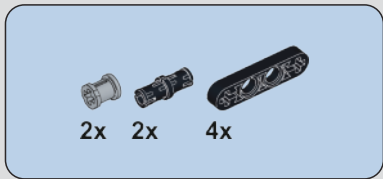
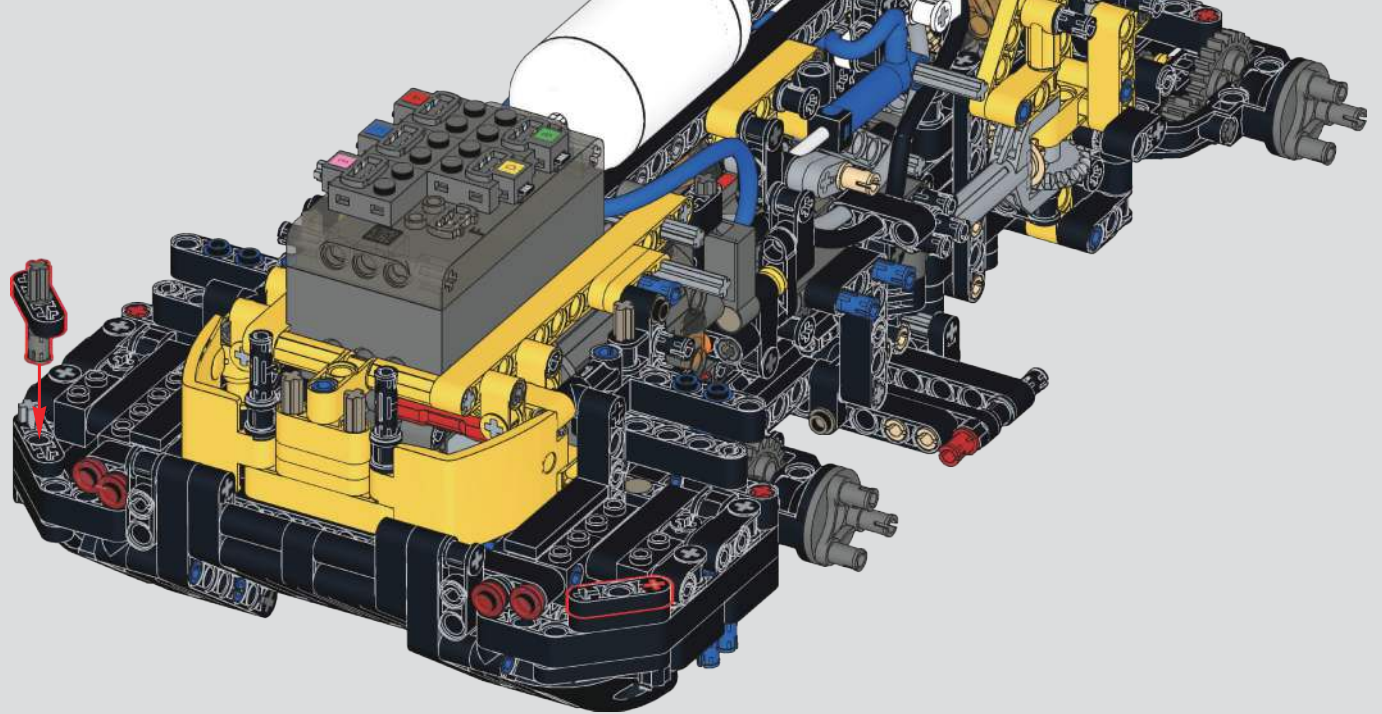

225

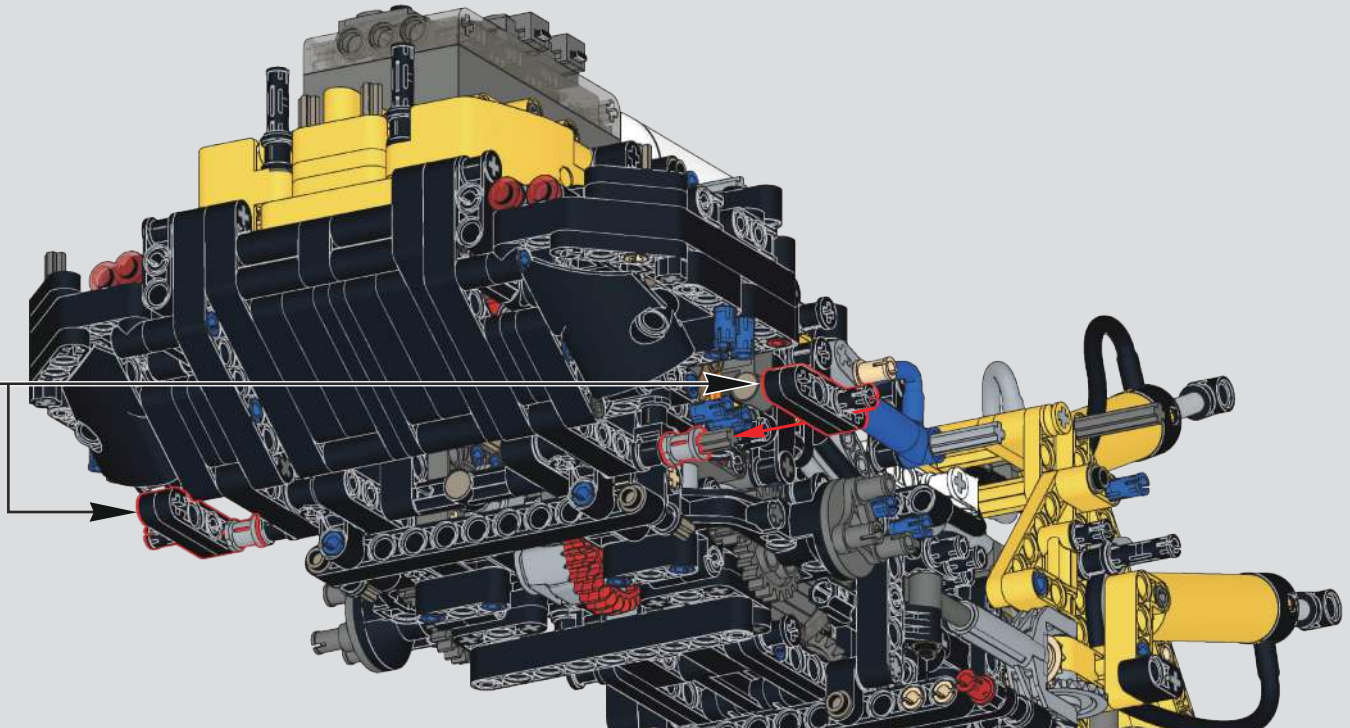
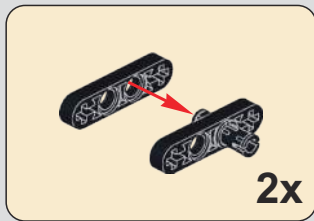

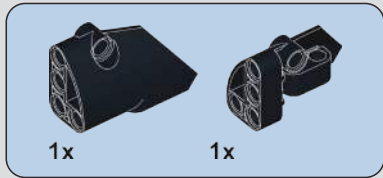

226

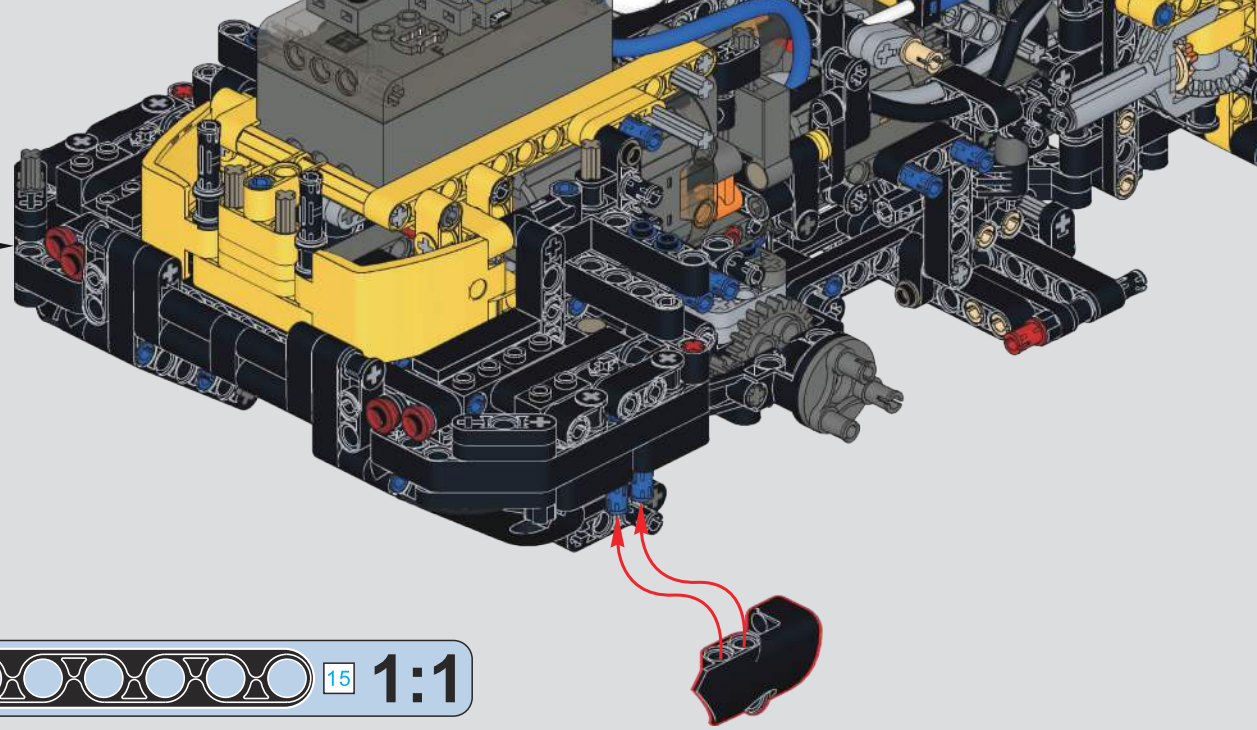
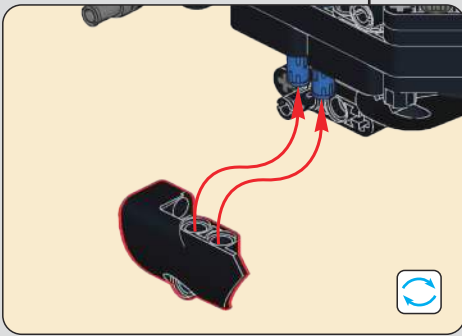

227

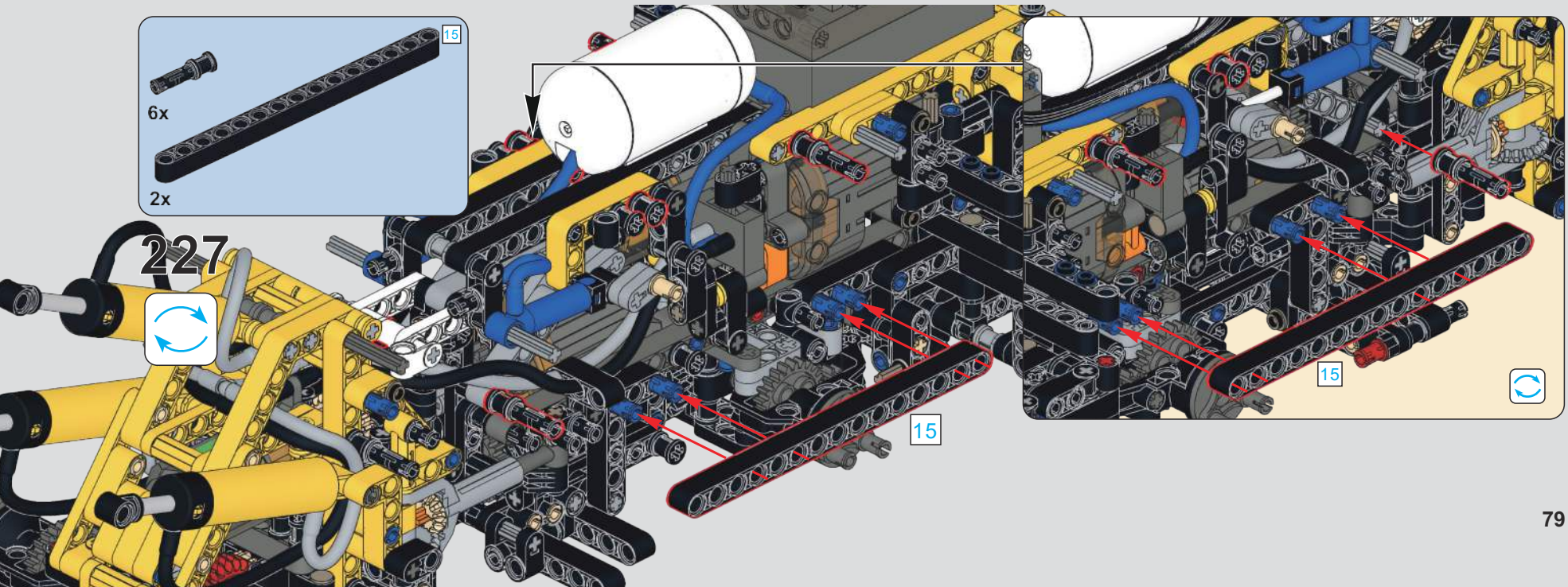

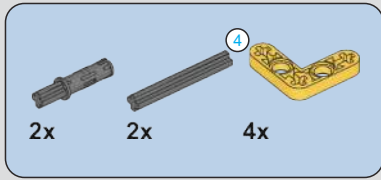

228

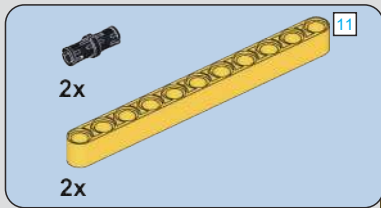
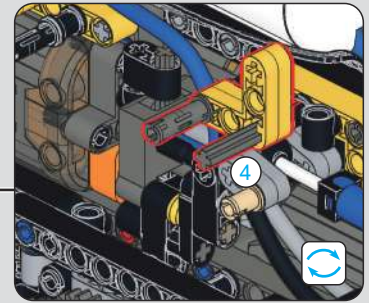
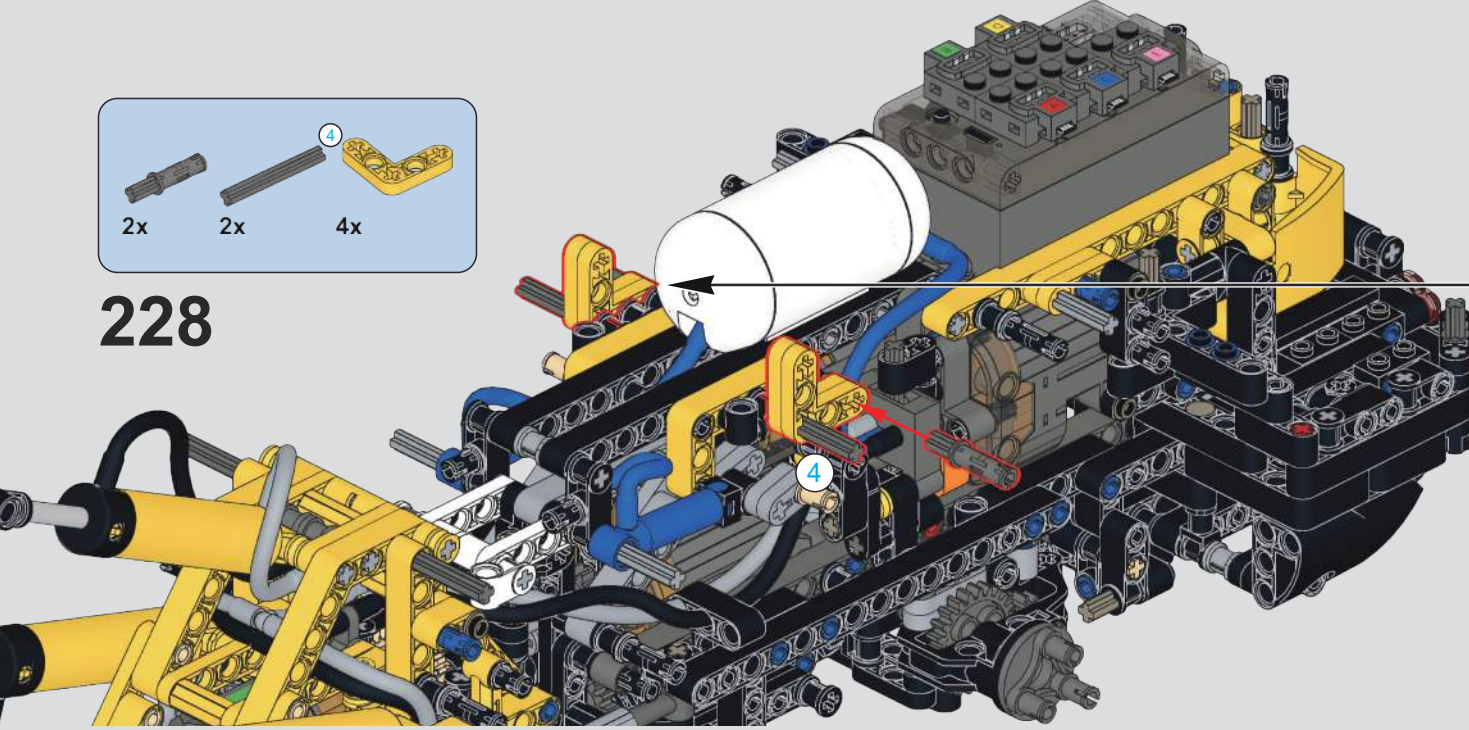

229

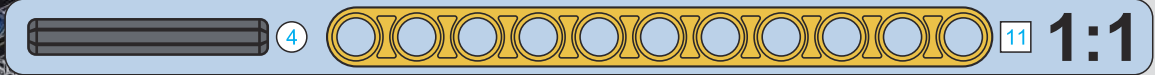
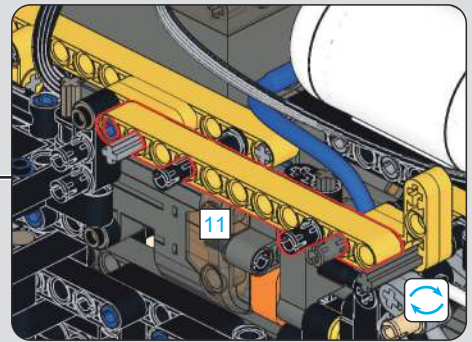
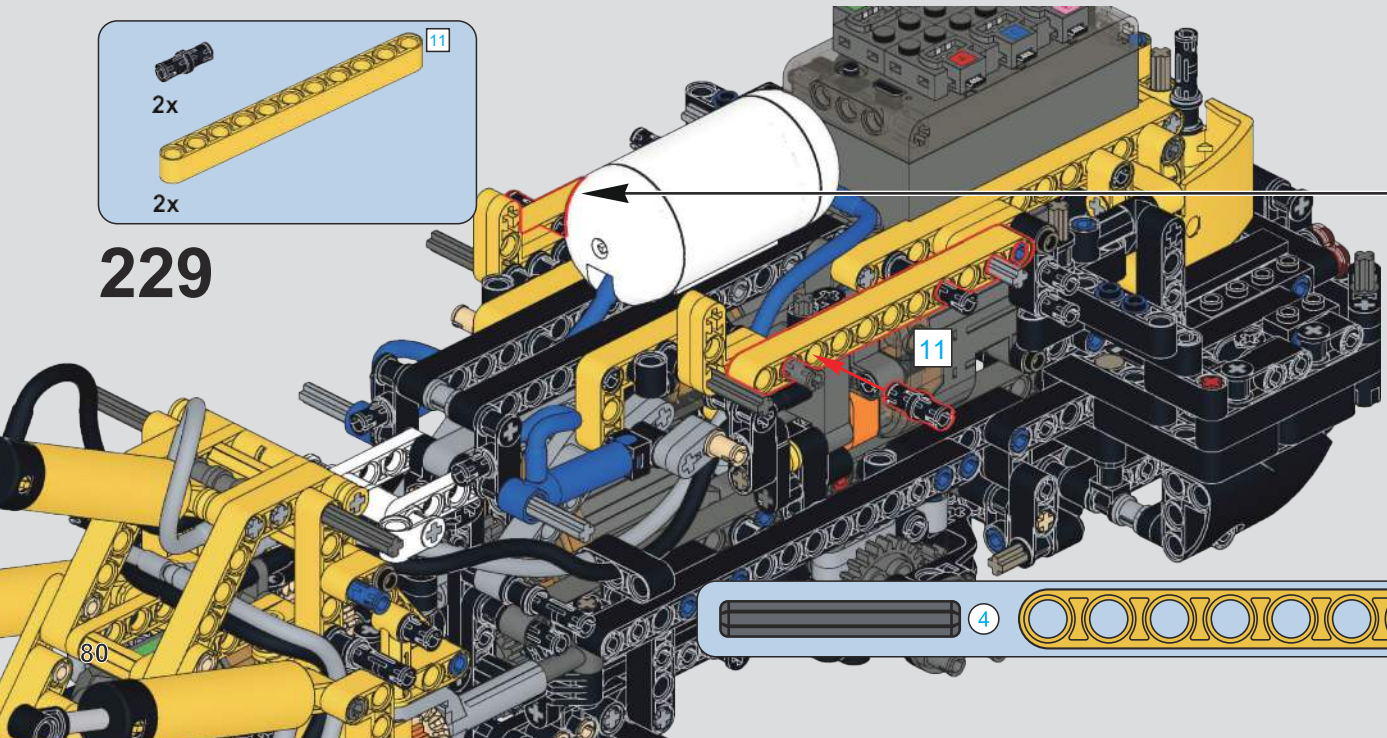

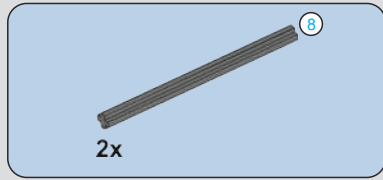

230

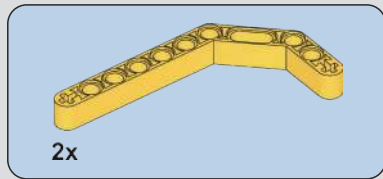
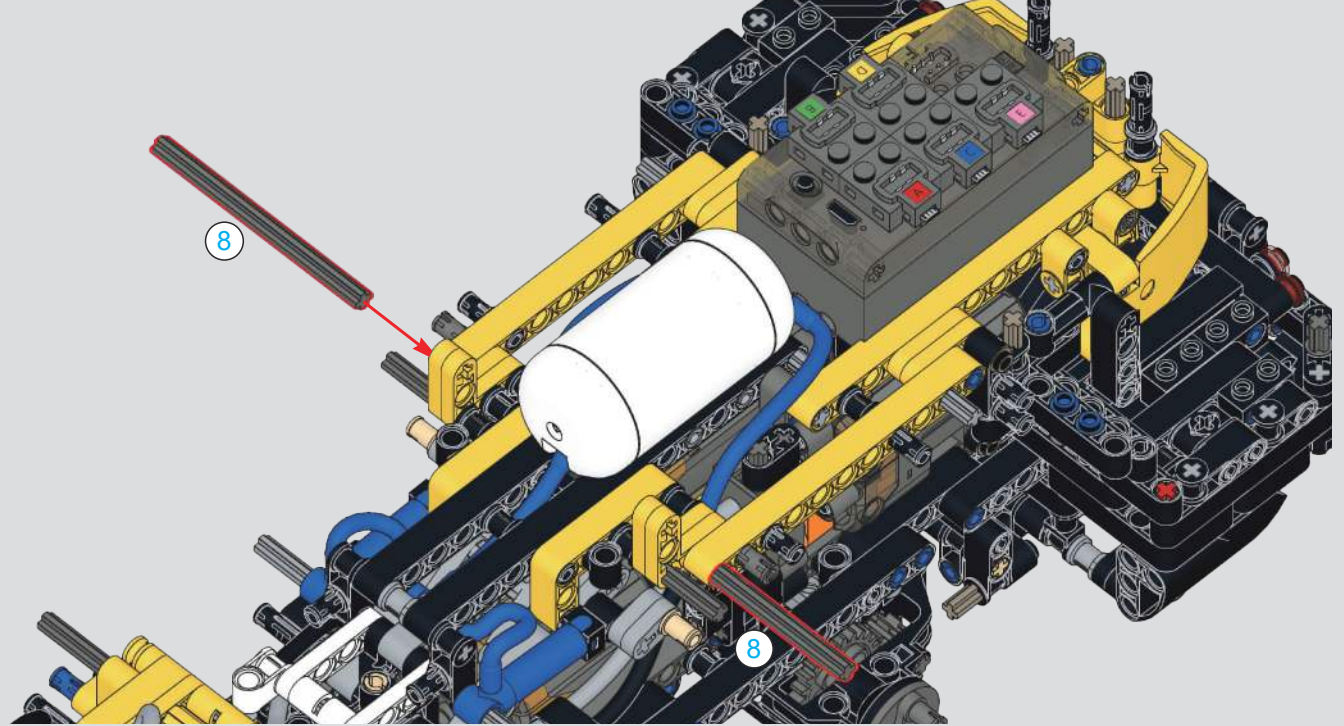

231

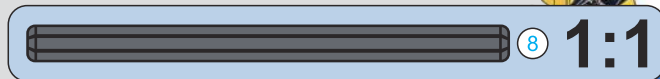
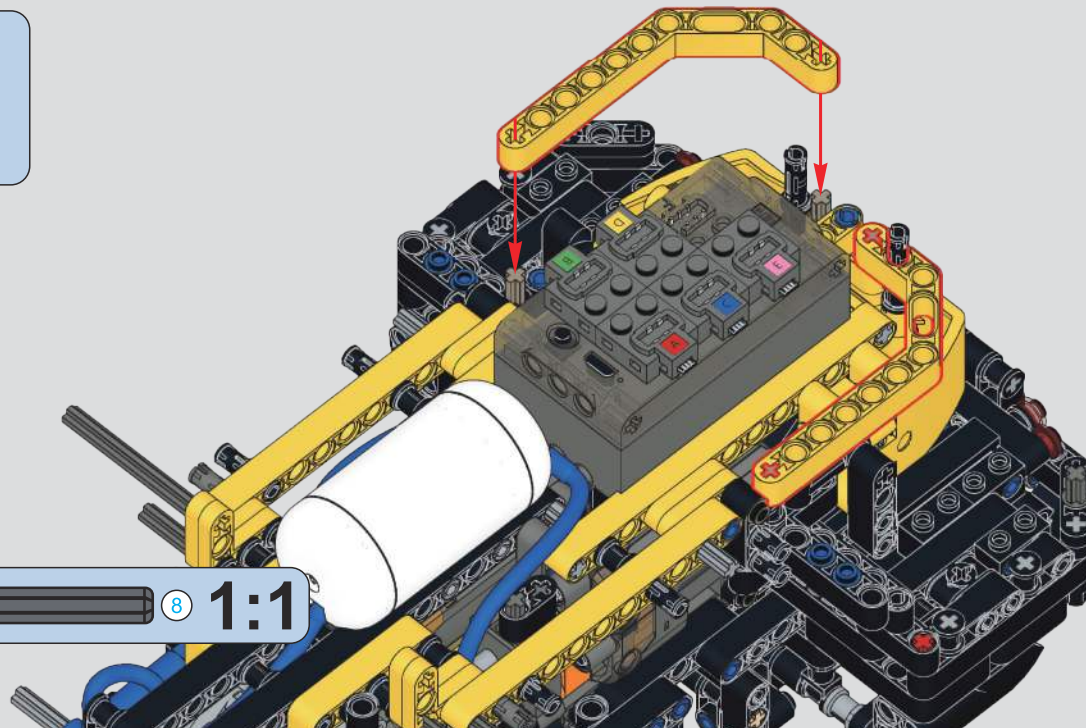

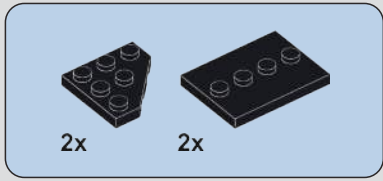

232

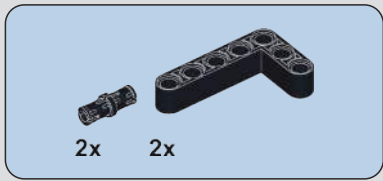
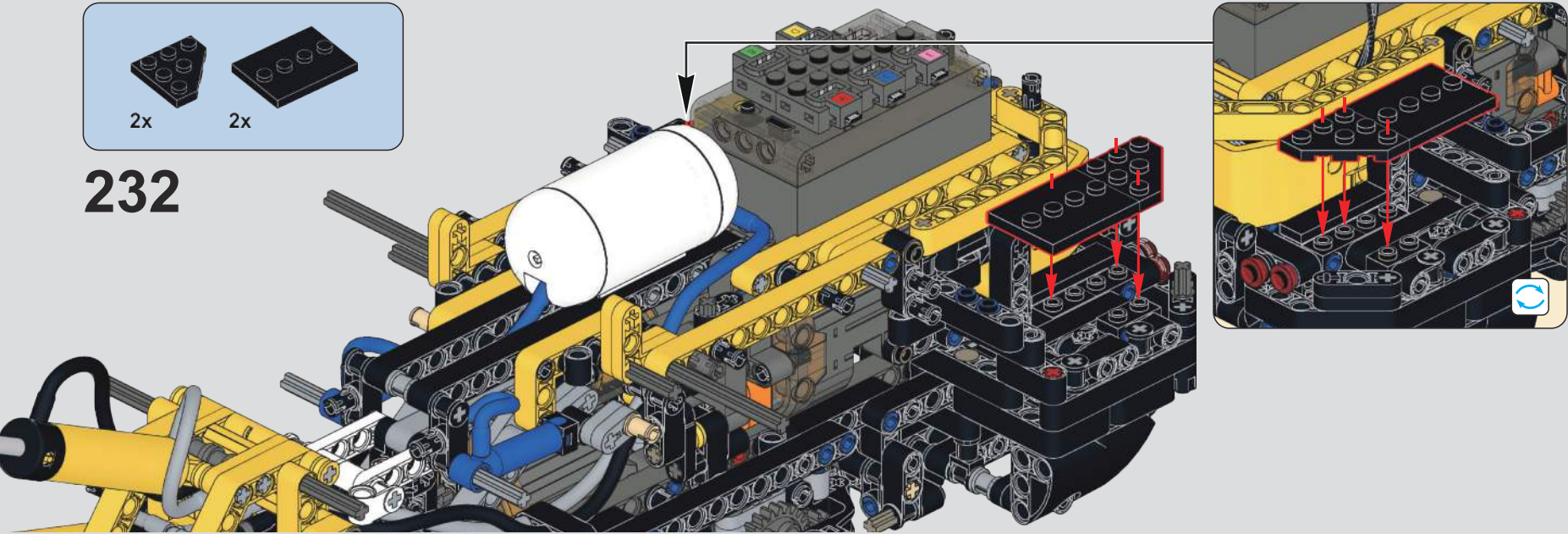

233

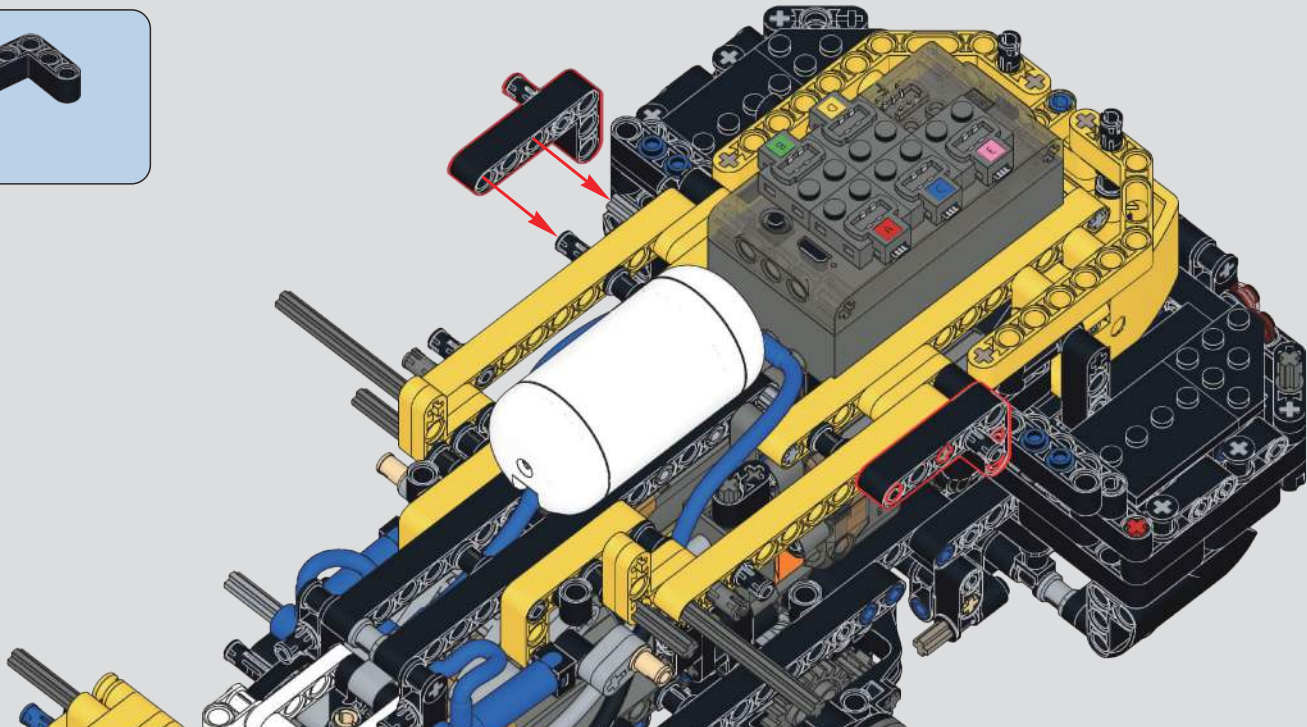

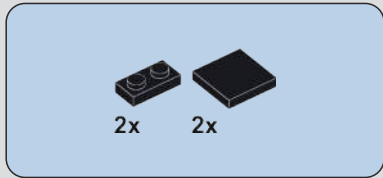

234

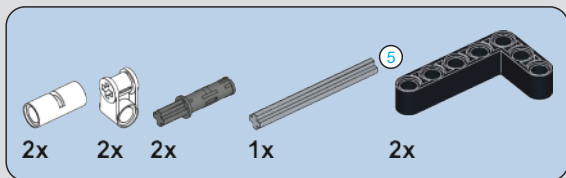
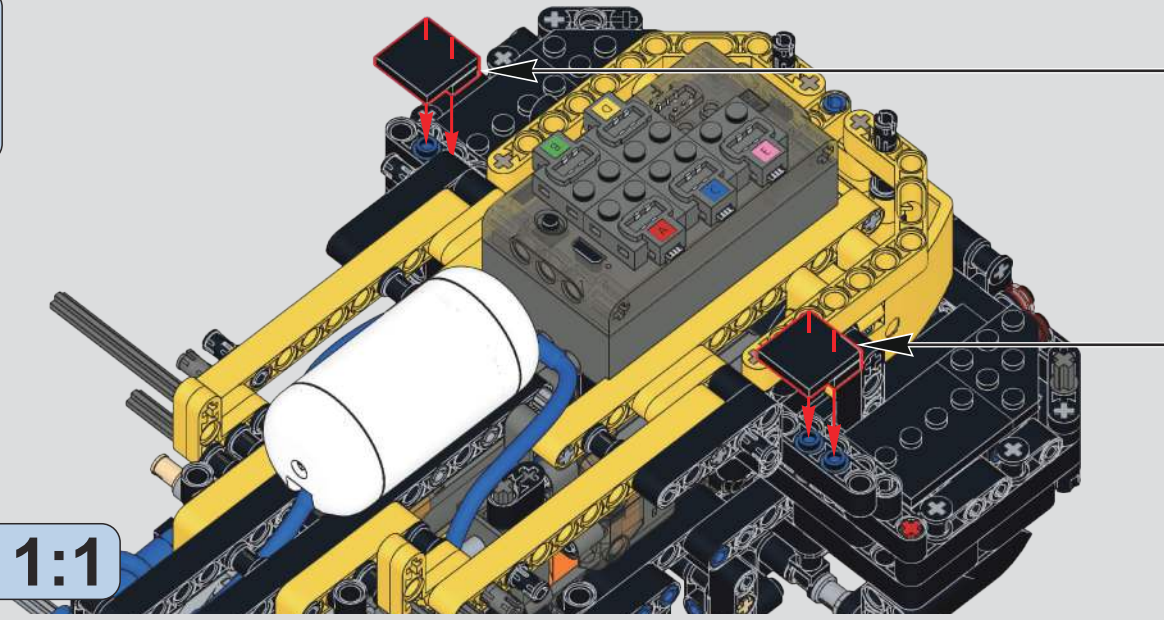
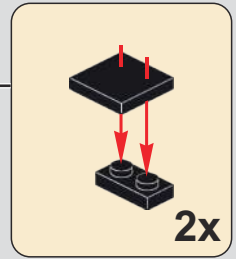

235

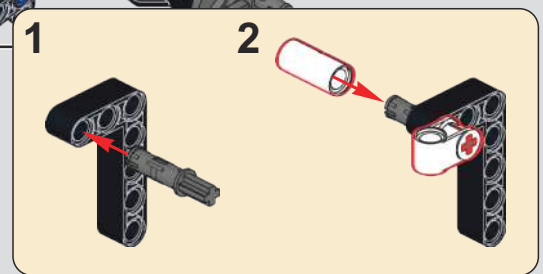
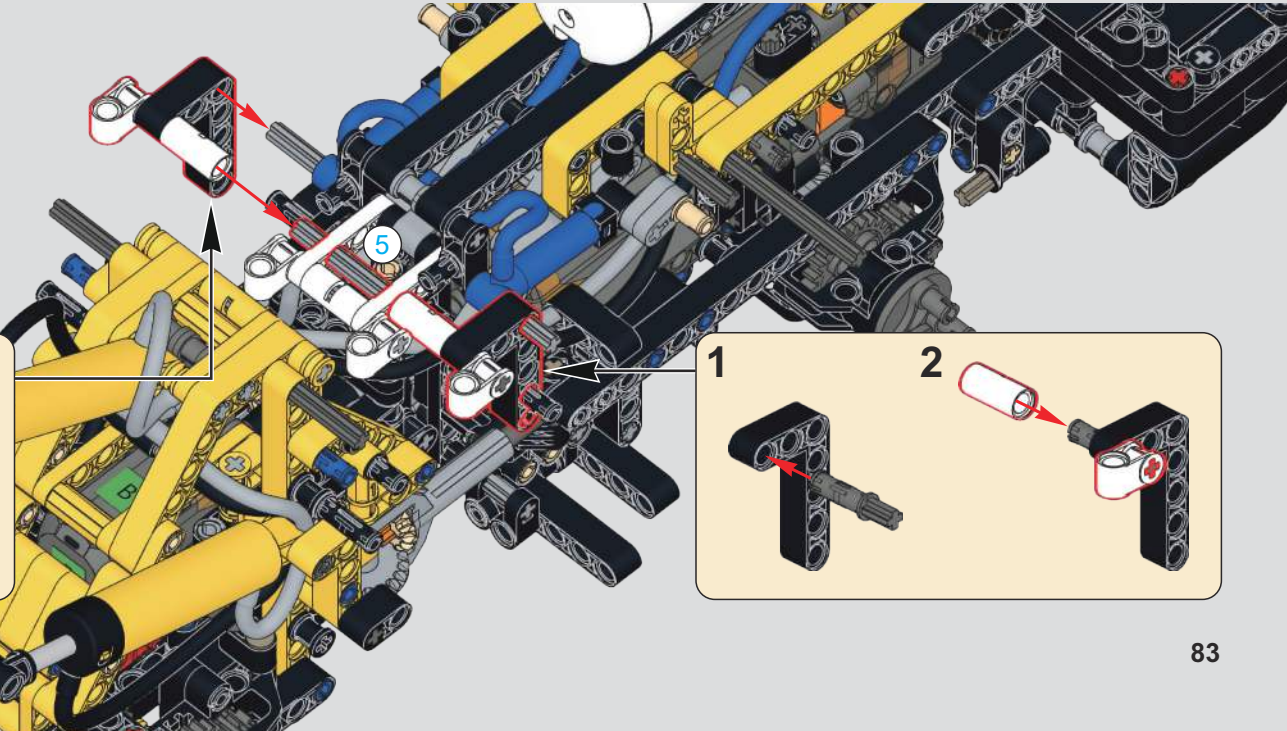
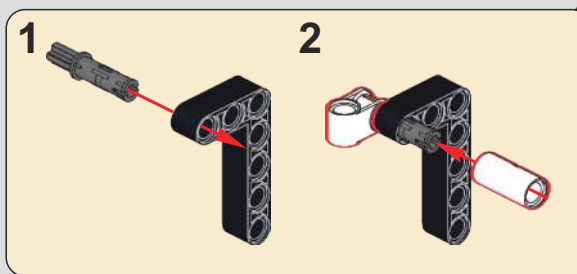



236

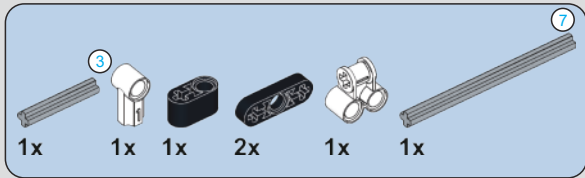
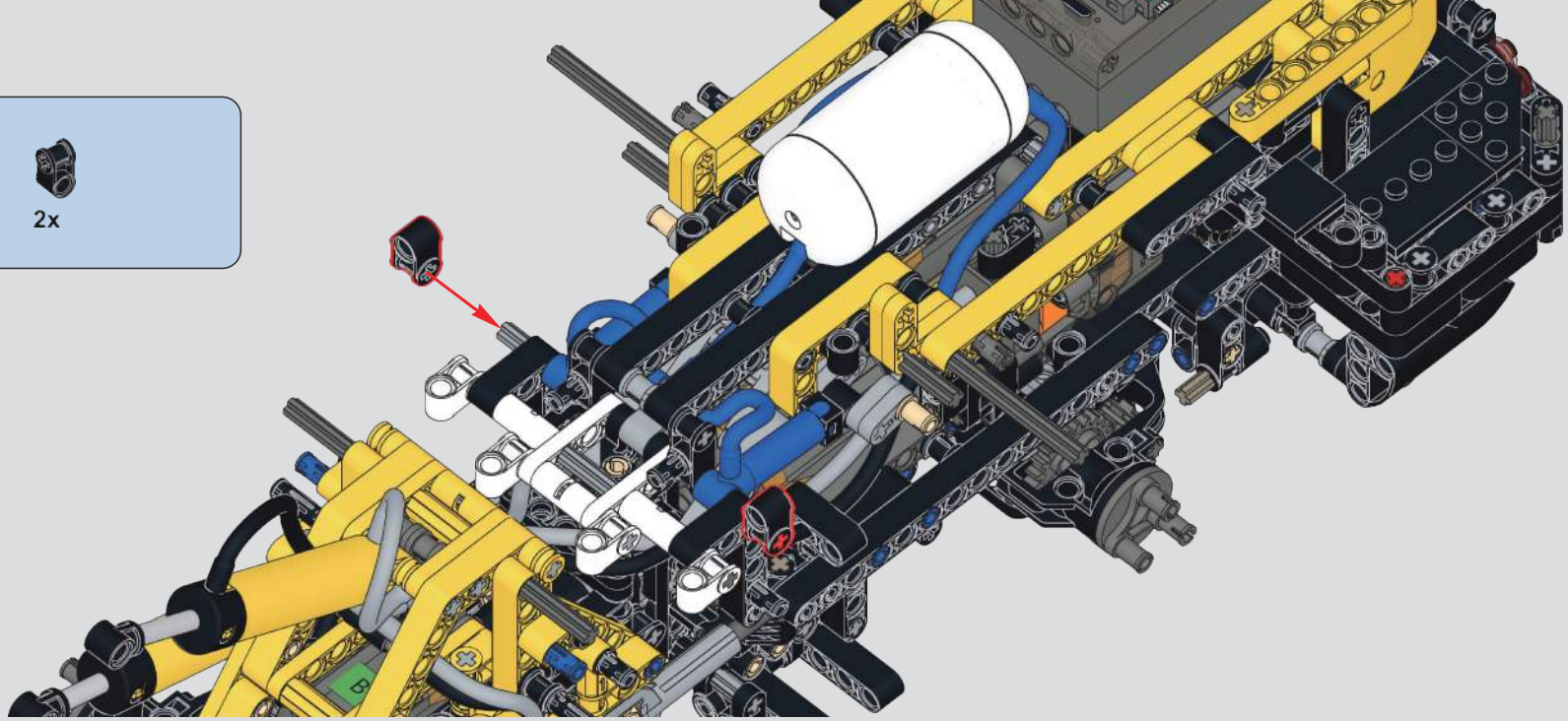

237

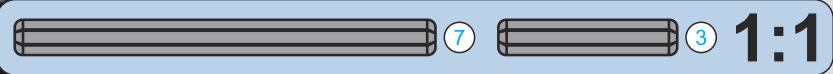
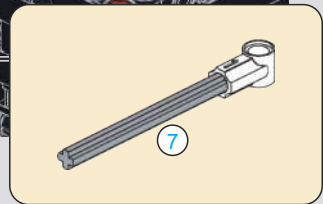
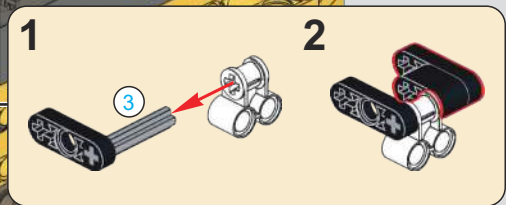
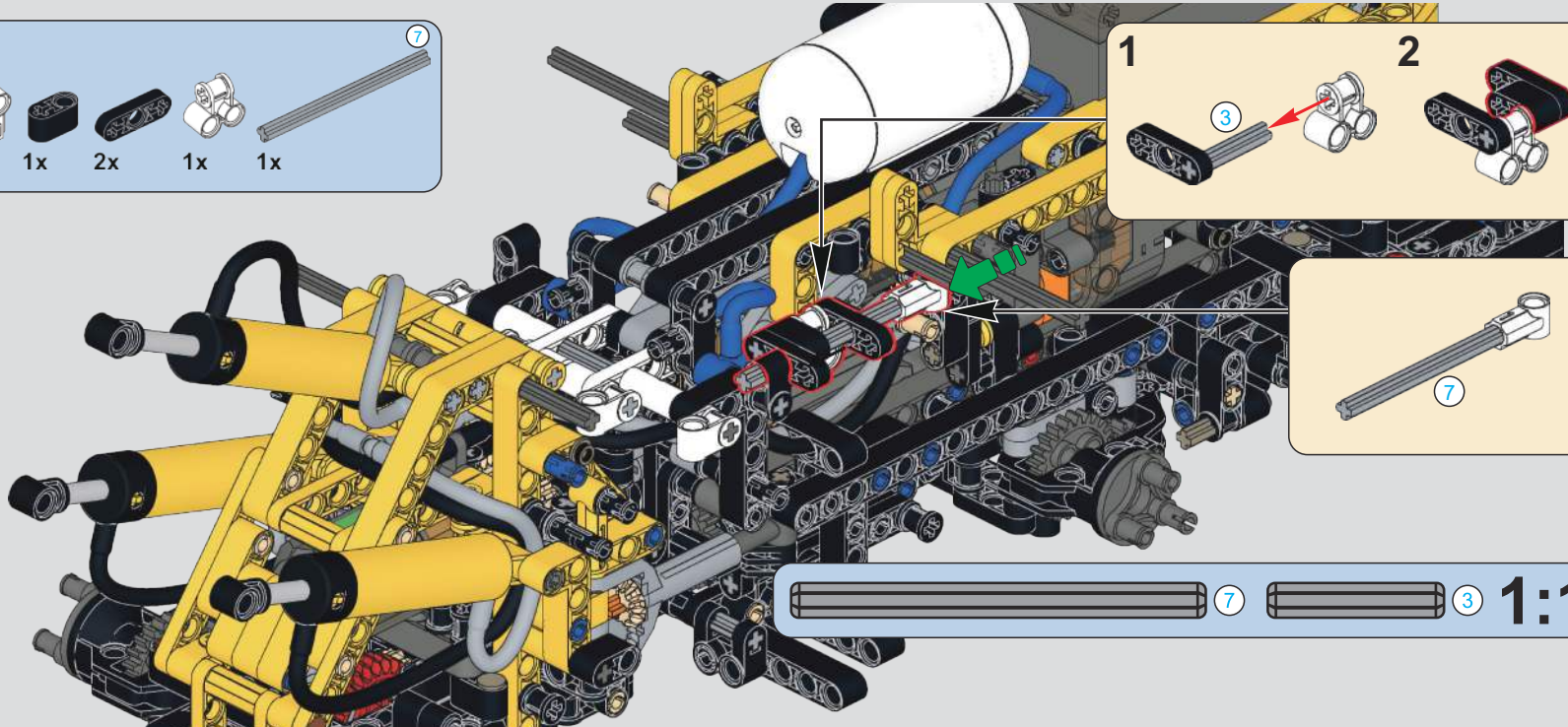

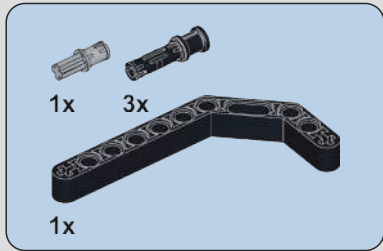

238

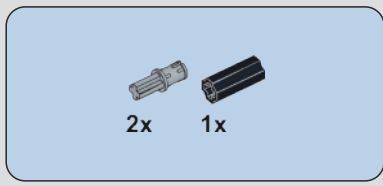
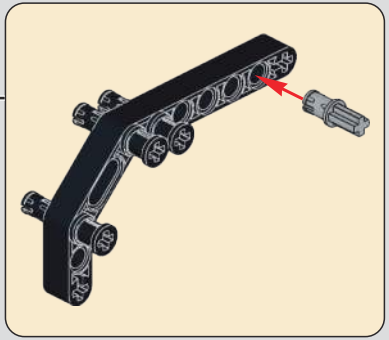
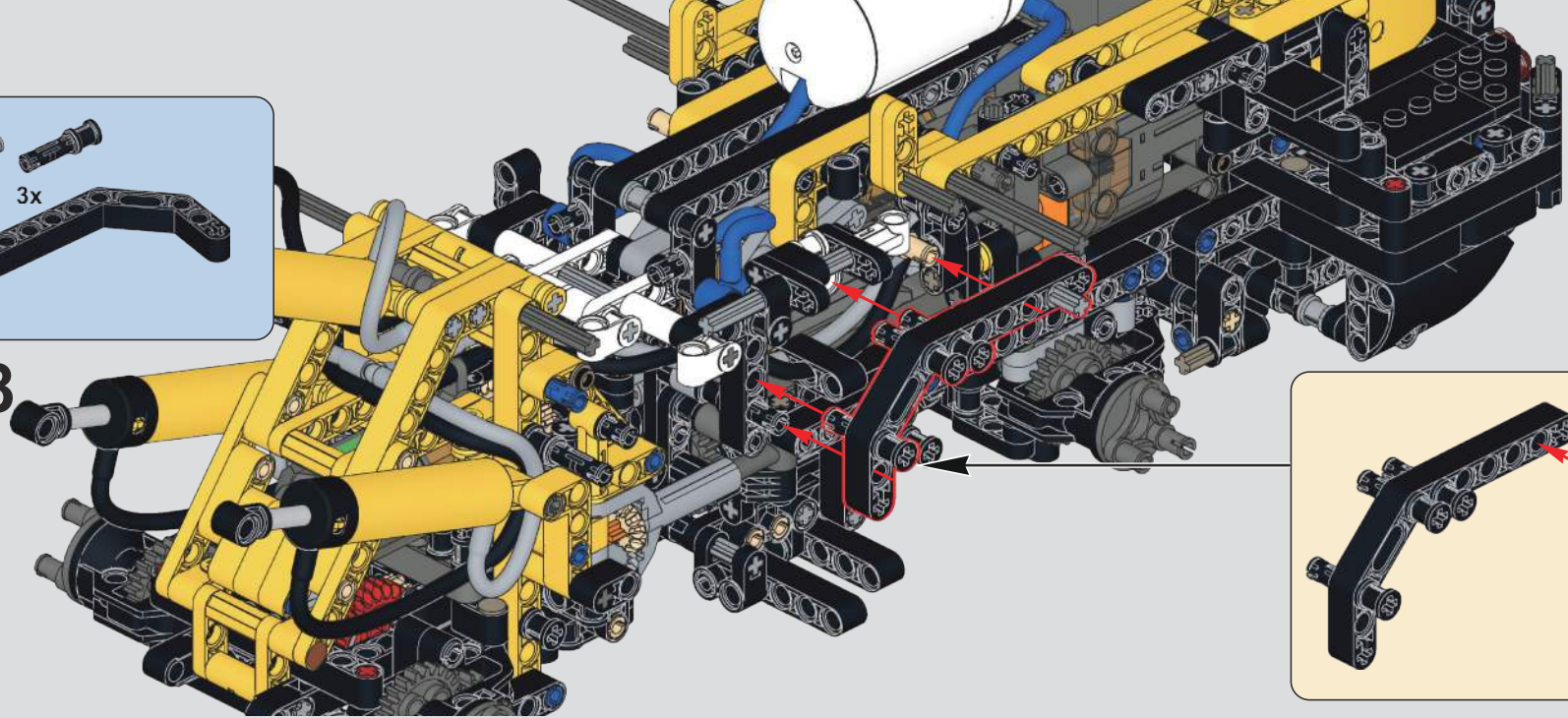

239

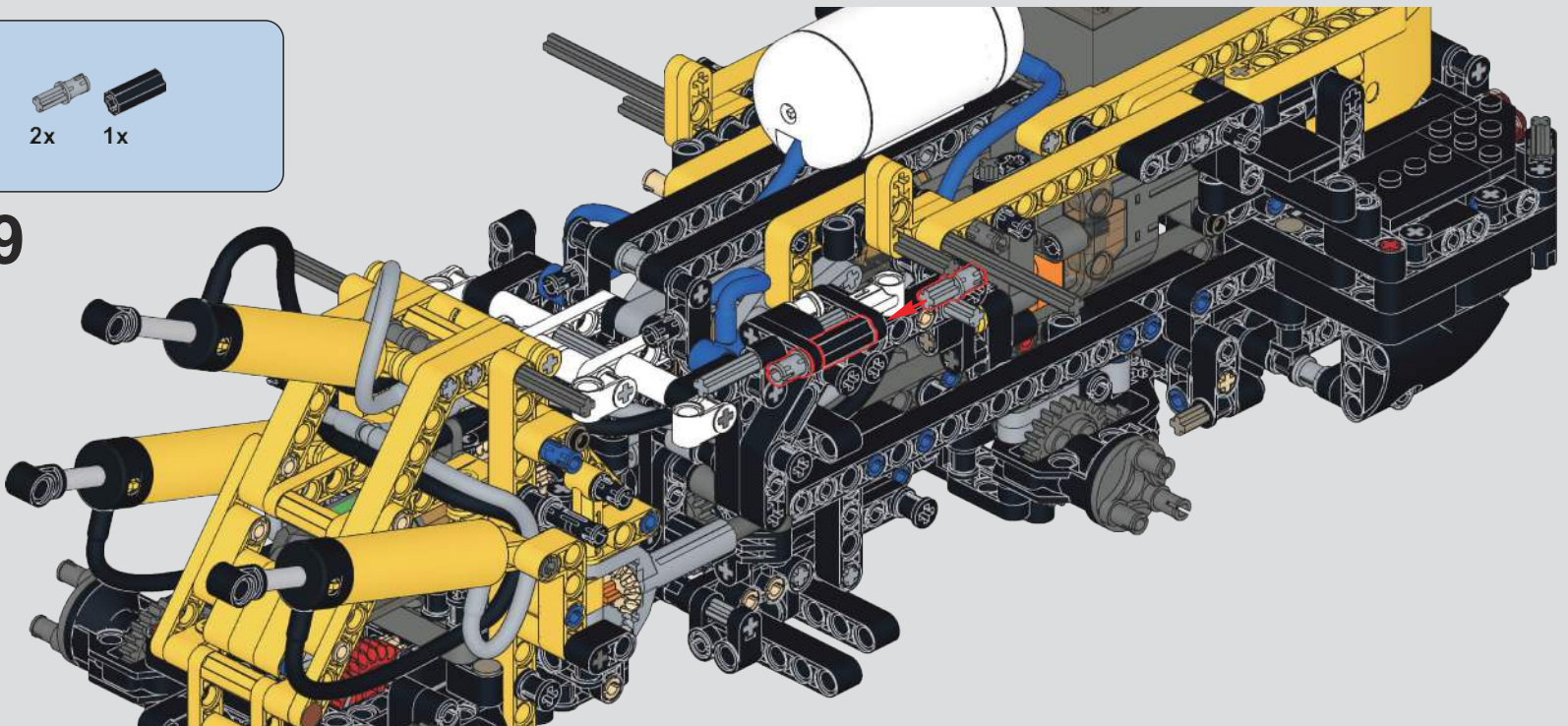

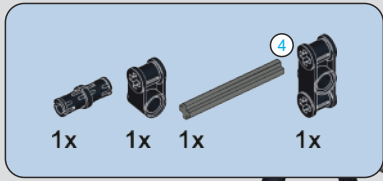

240

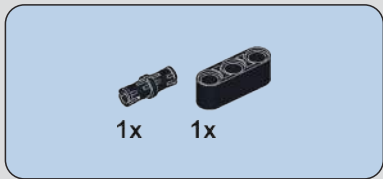
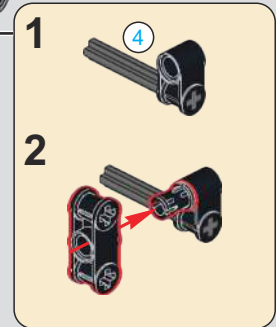
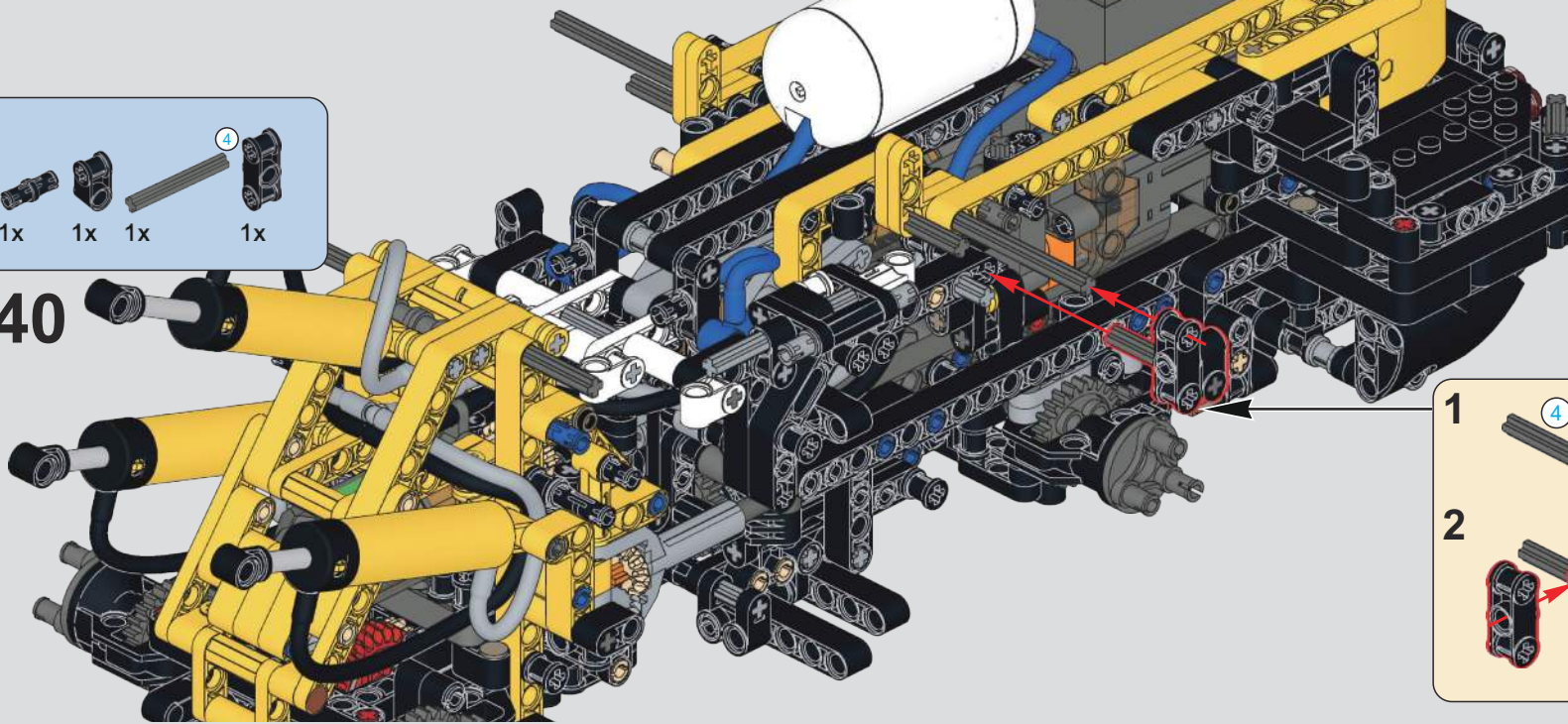

241

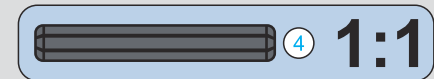
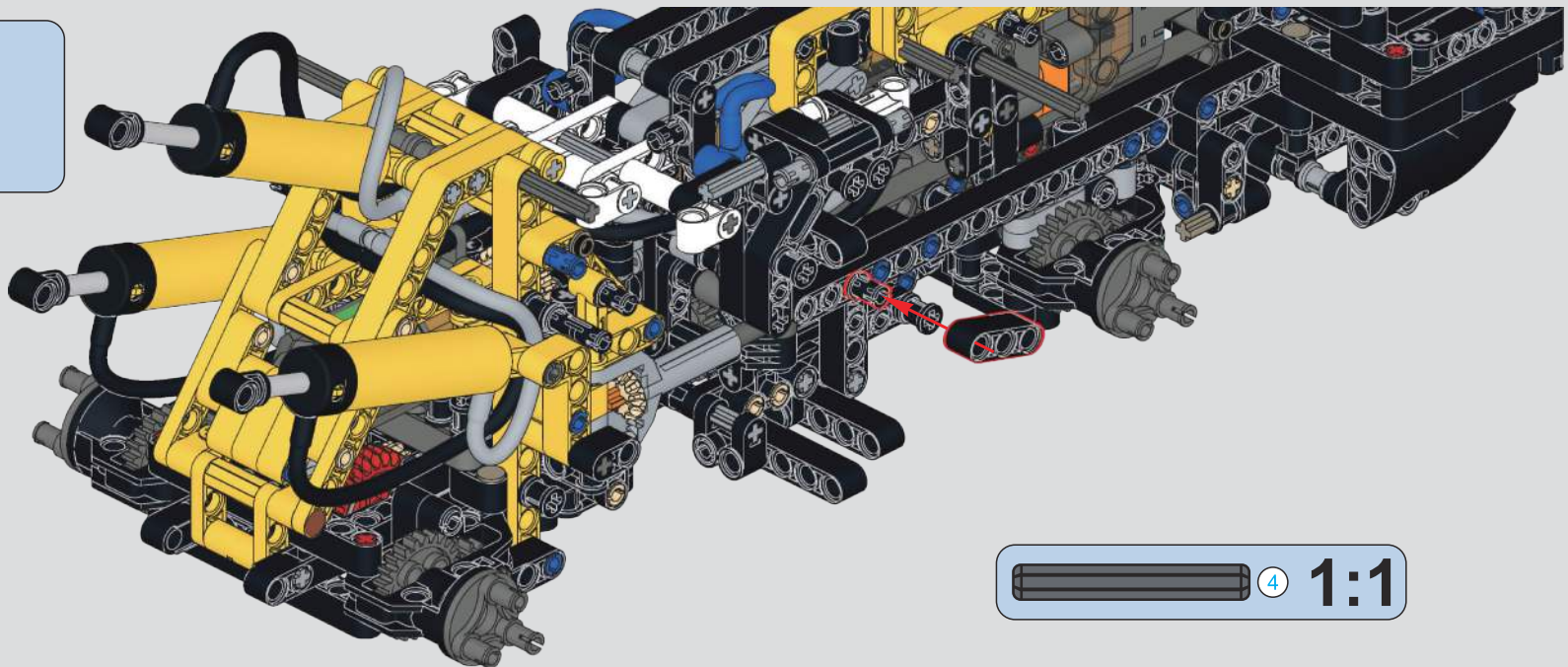

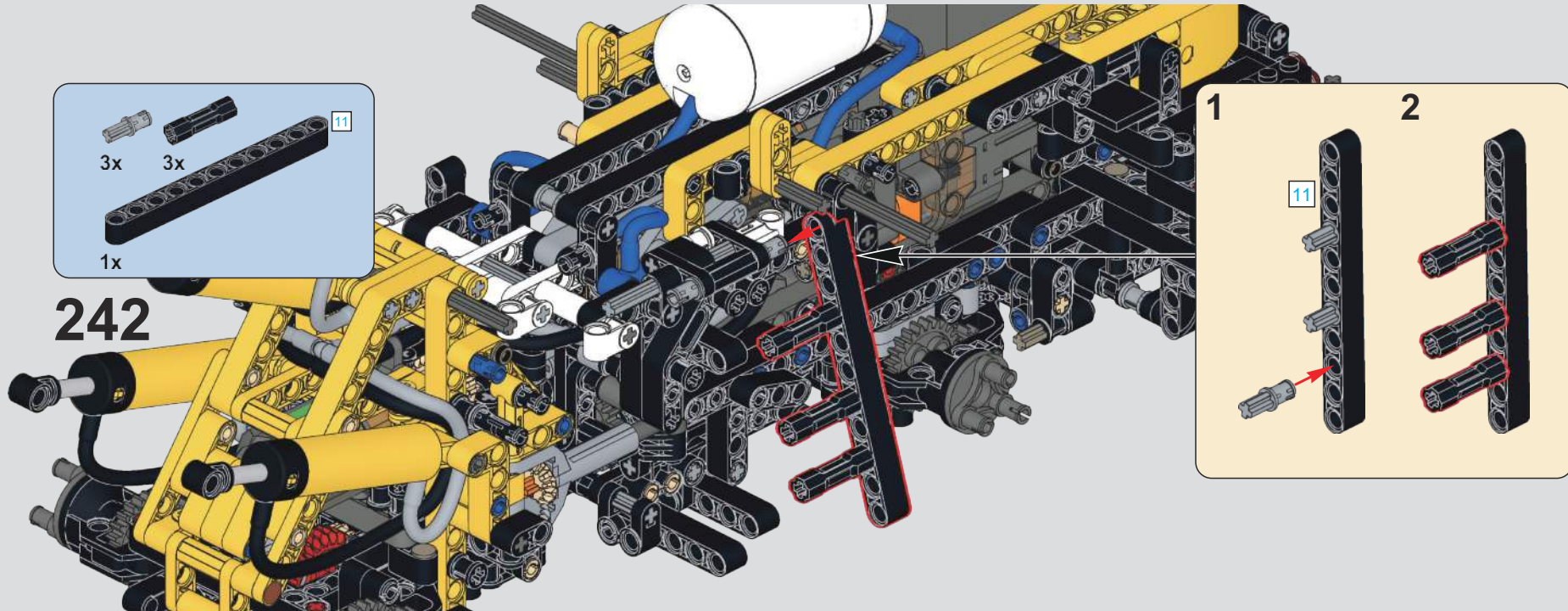

242

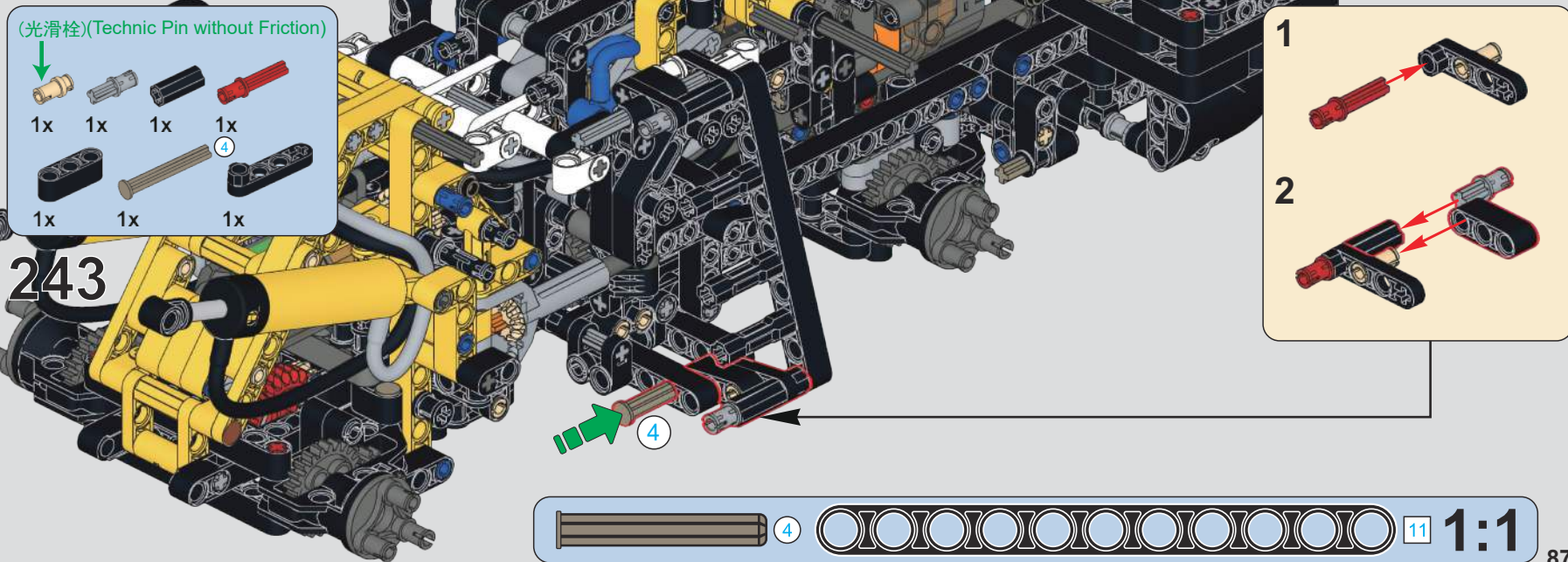

243

- (光滑栓)(Technic Pin without Friction)
- 1x
 - 1x
 - 1x
 - 1x
 - 1x
 - 1x
 - 1x



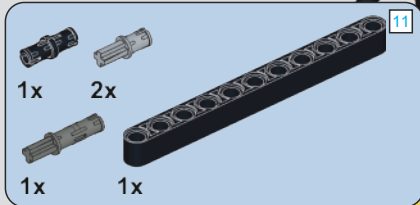

244

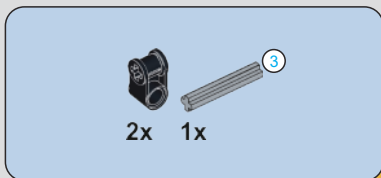
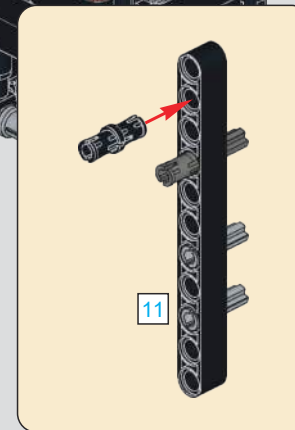
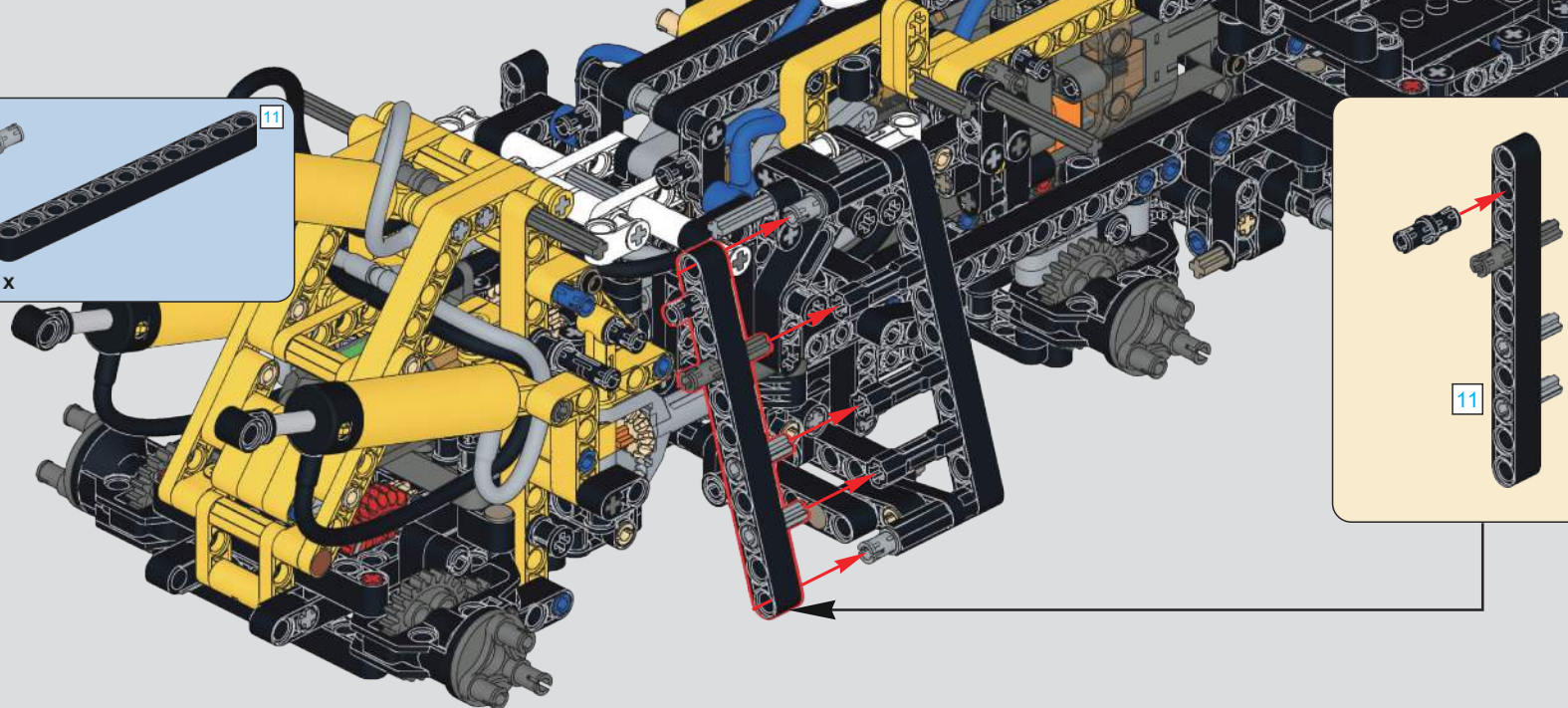

245

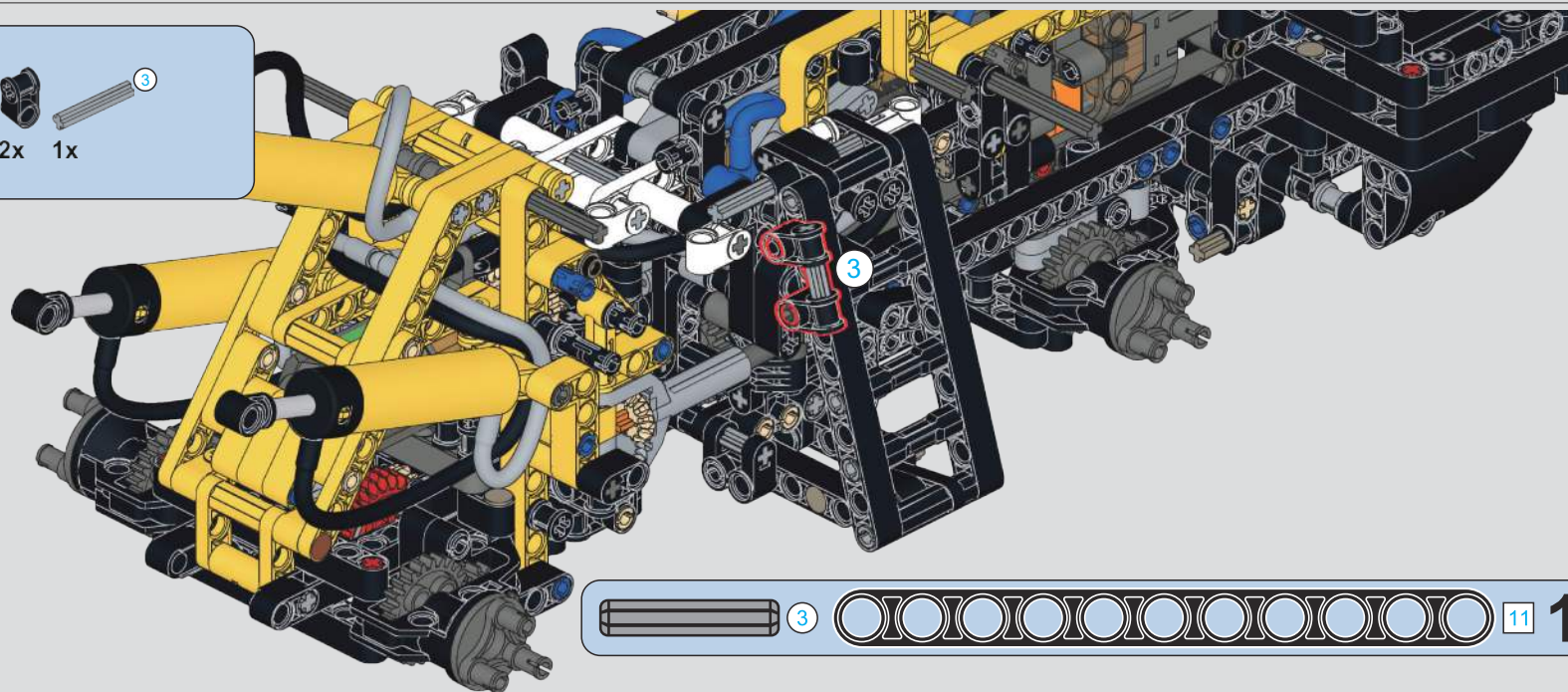

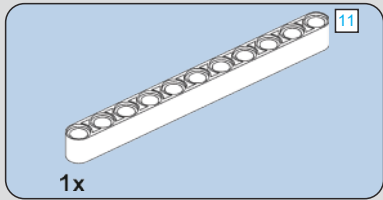

246

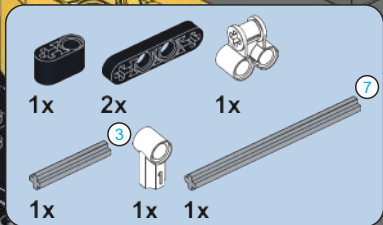
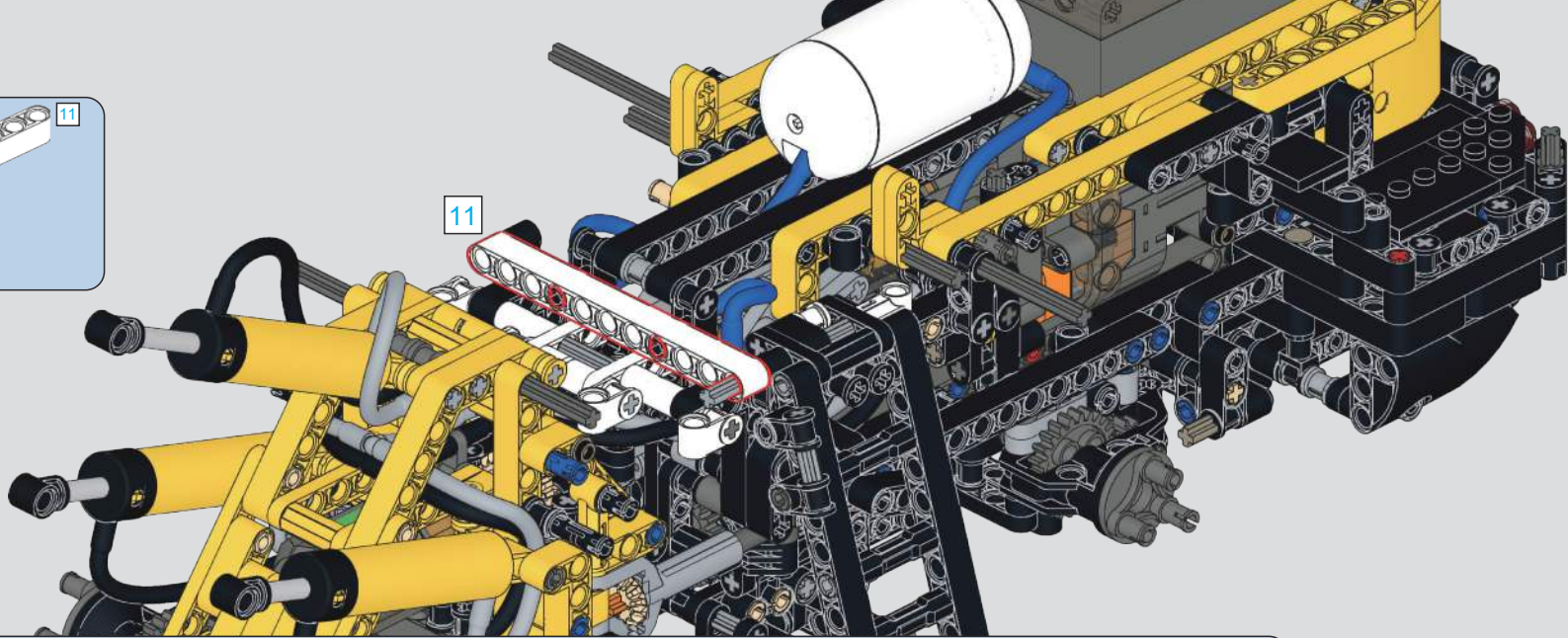

247

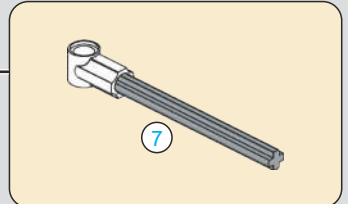
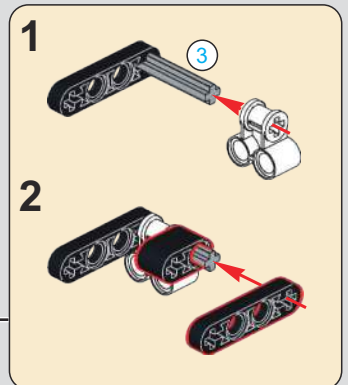
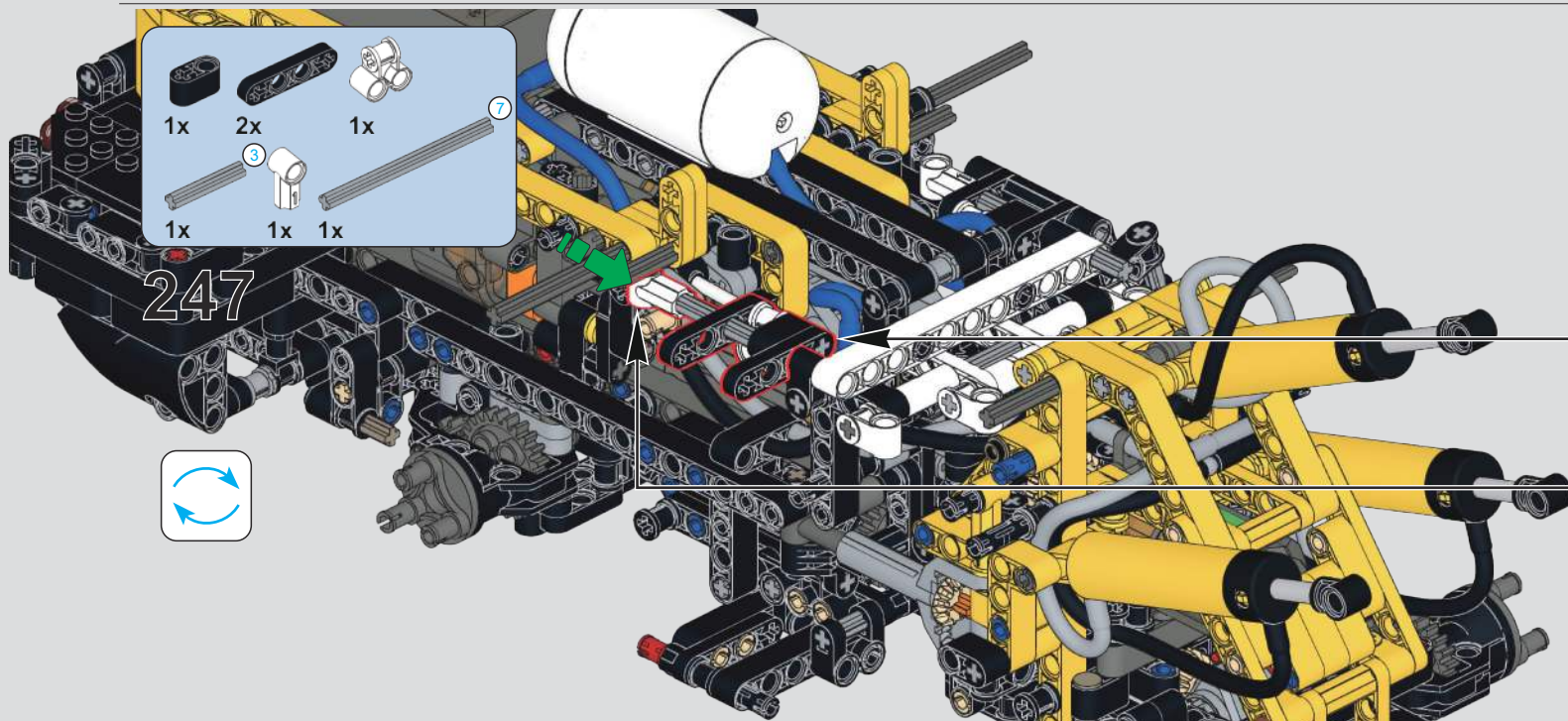

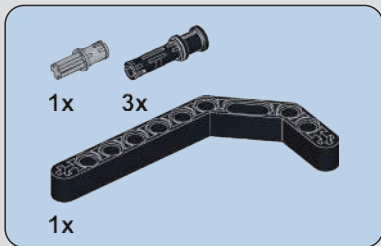

248

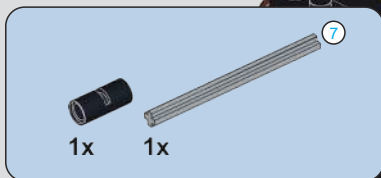
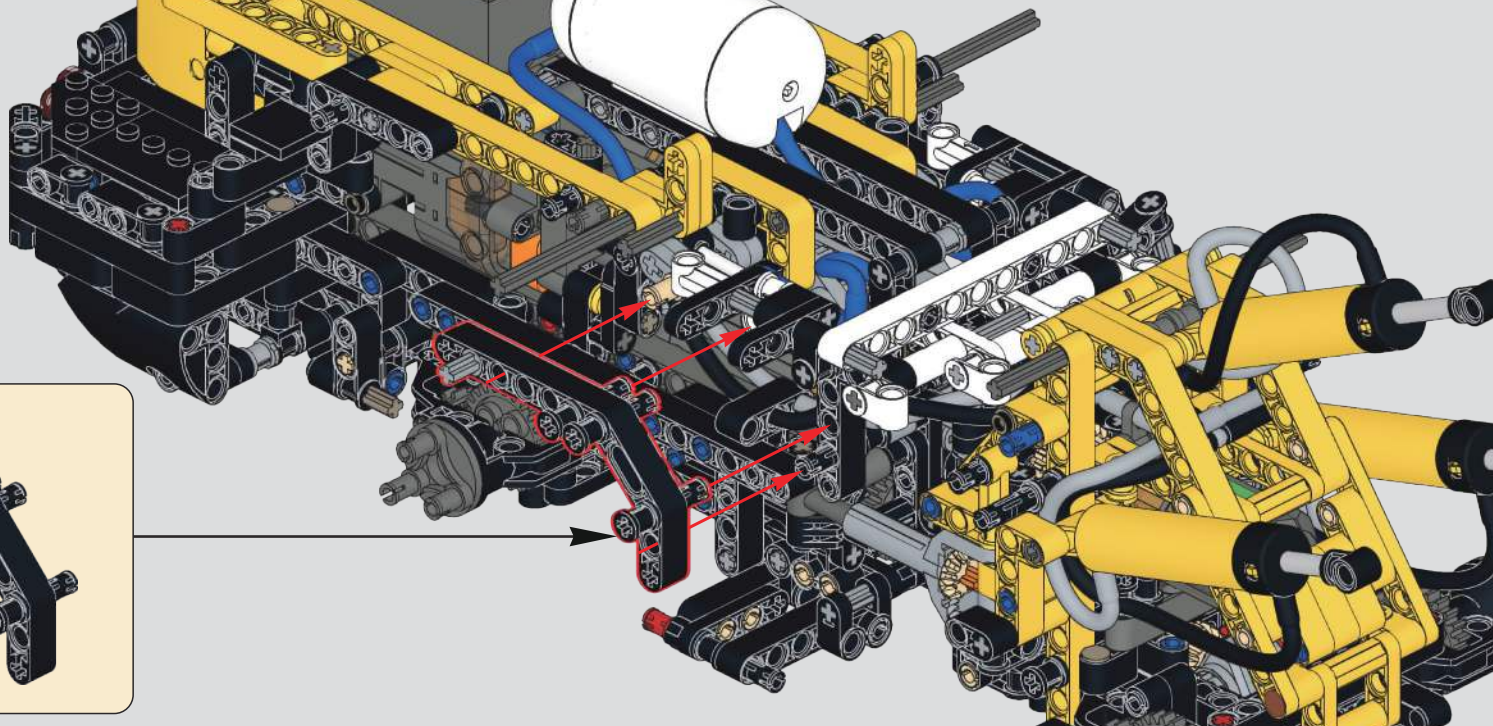
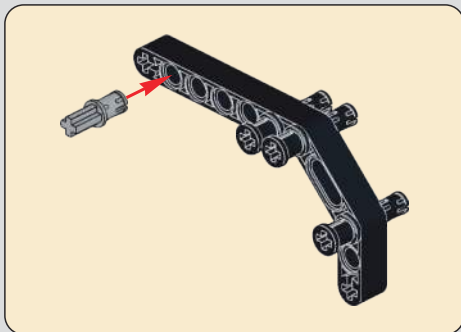

249

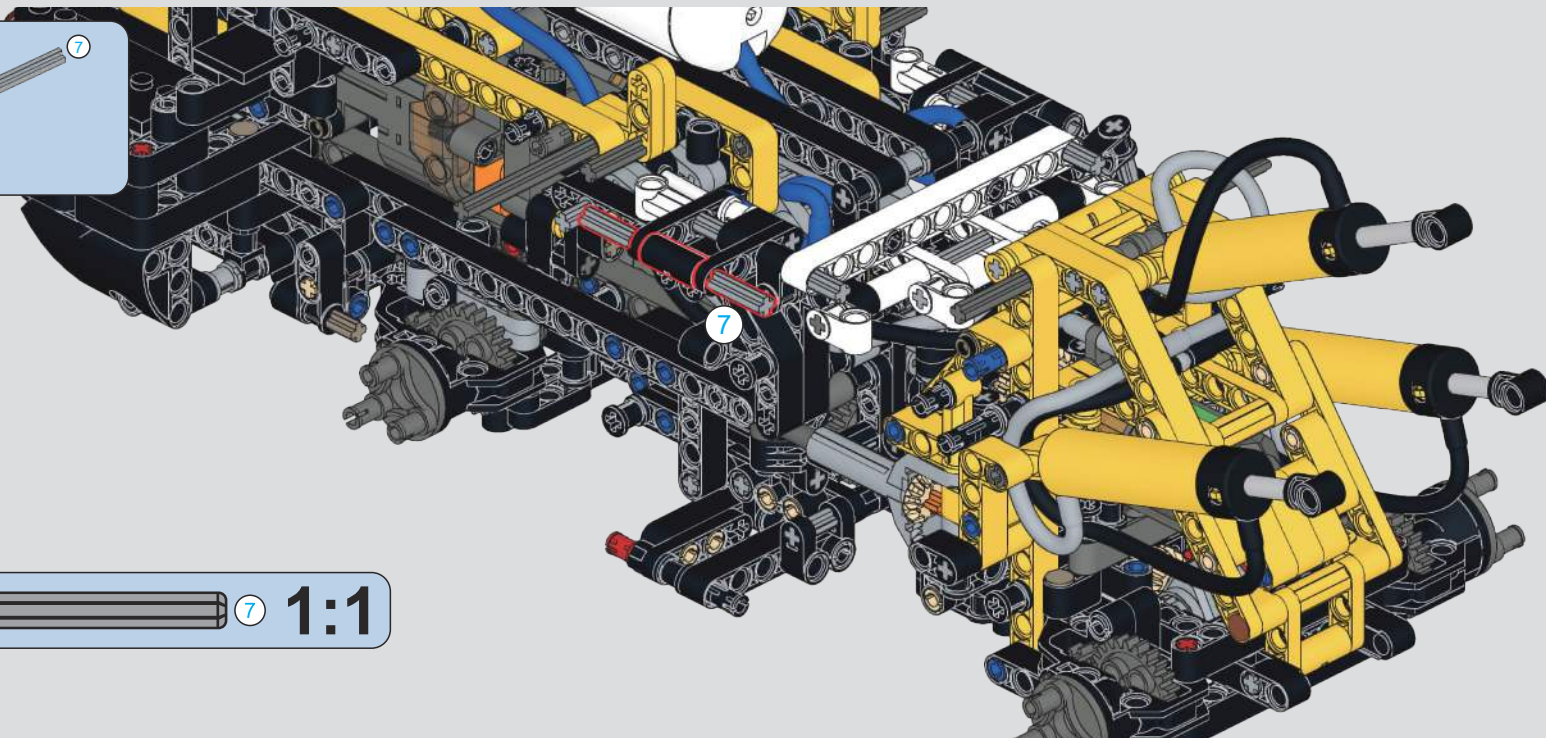

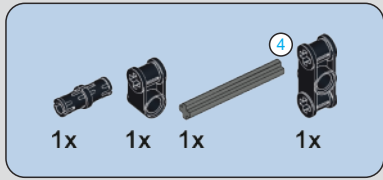

250

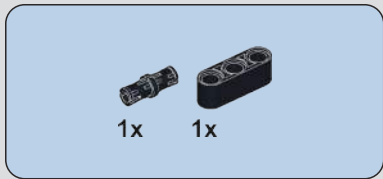
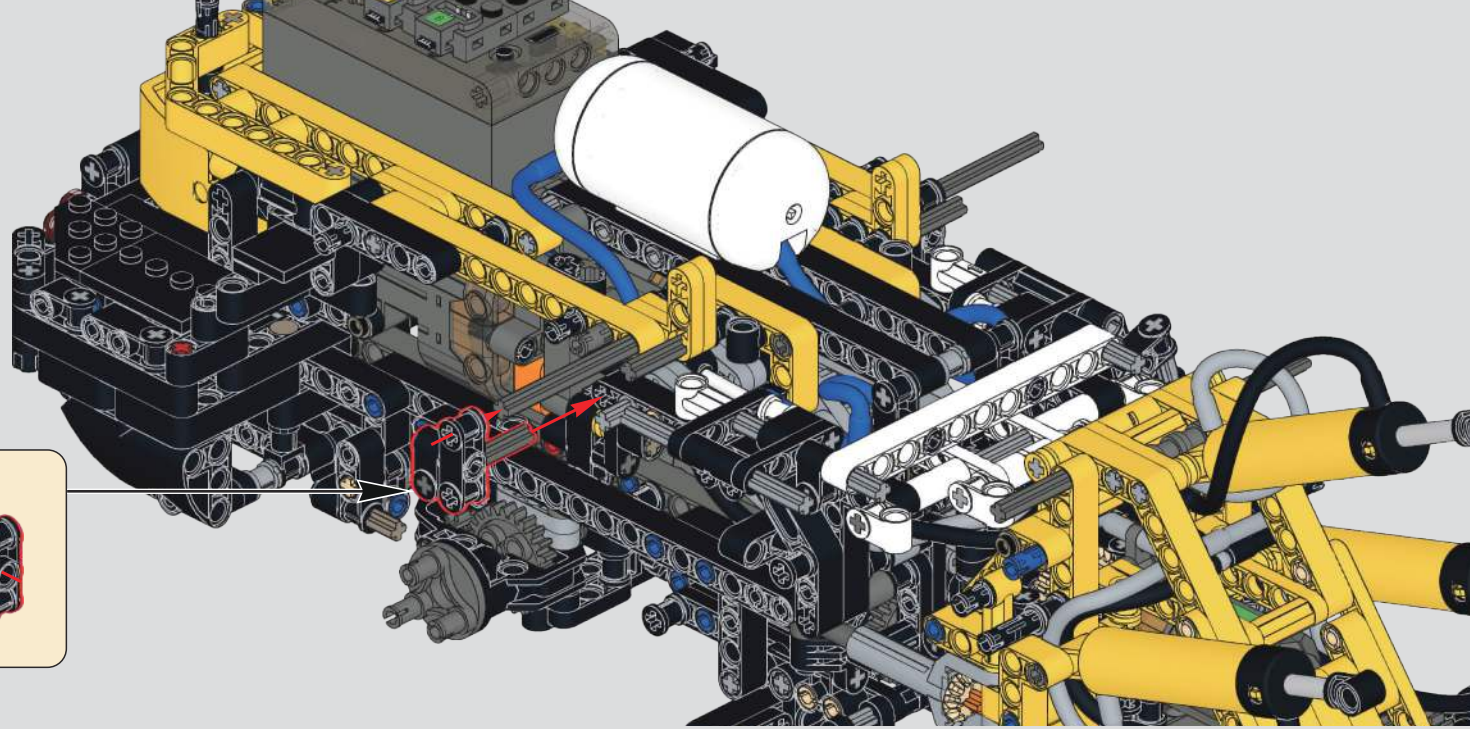
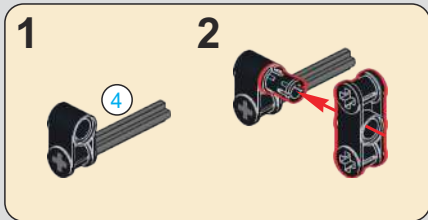

251

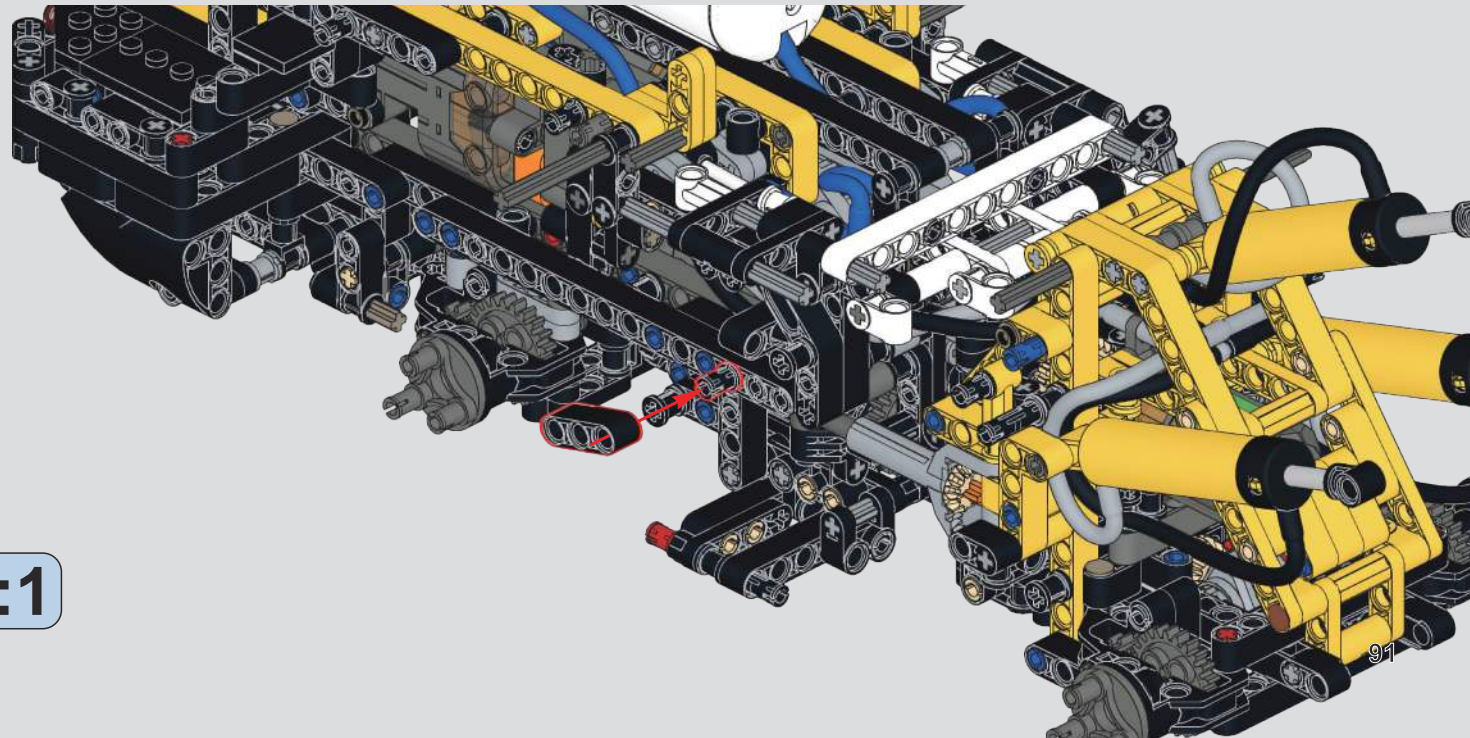

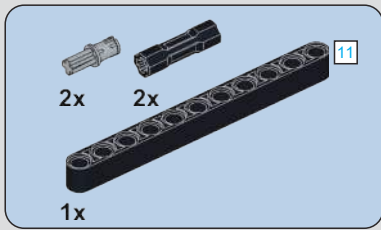

252

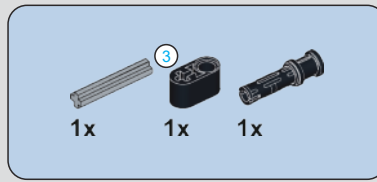
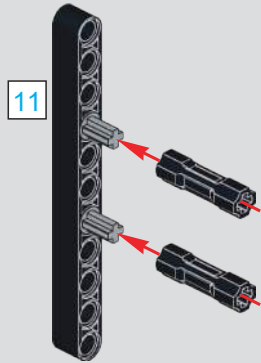

253

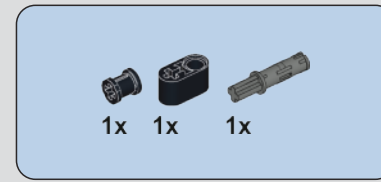
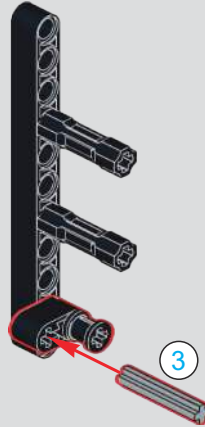

254

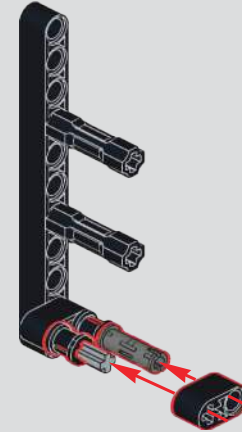

255

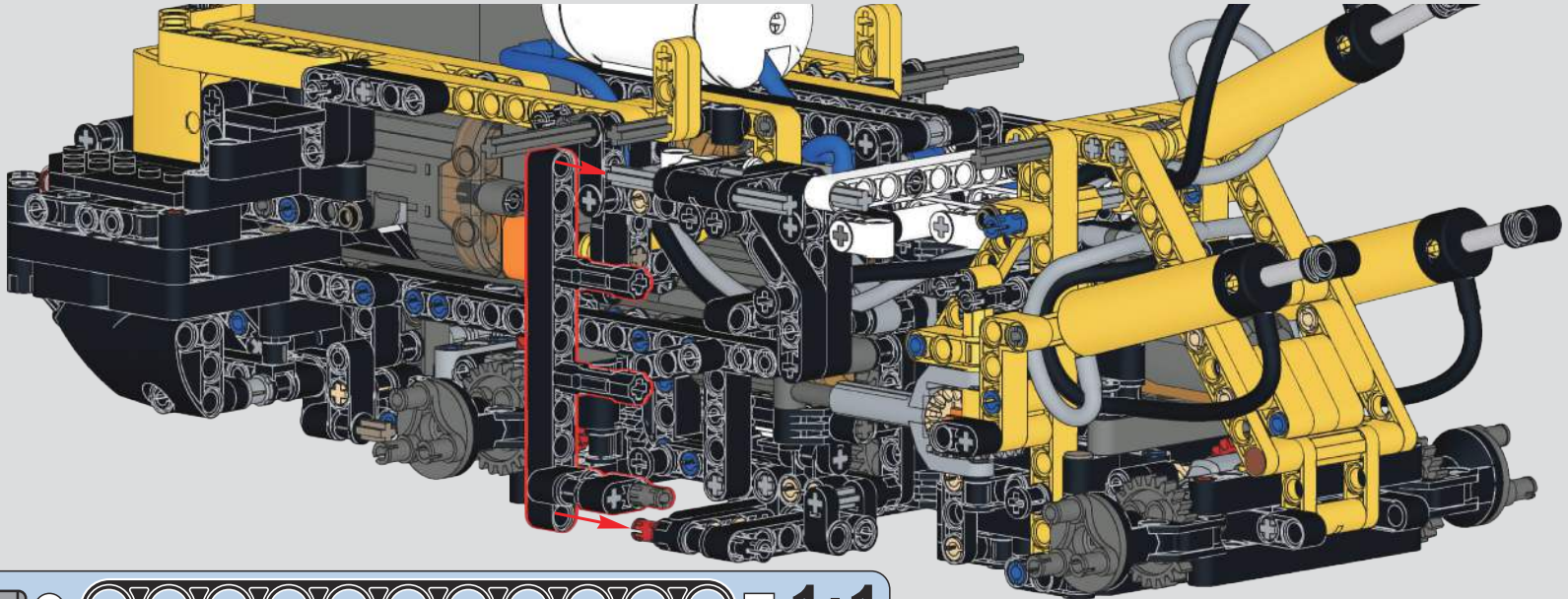

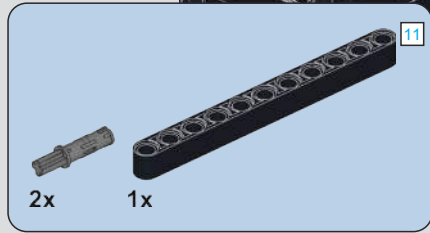

256

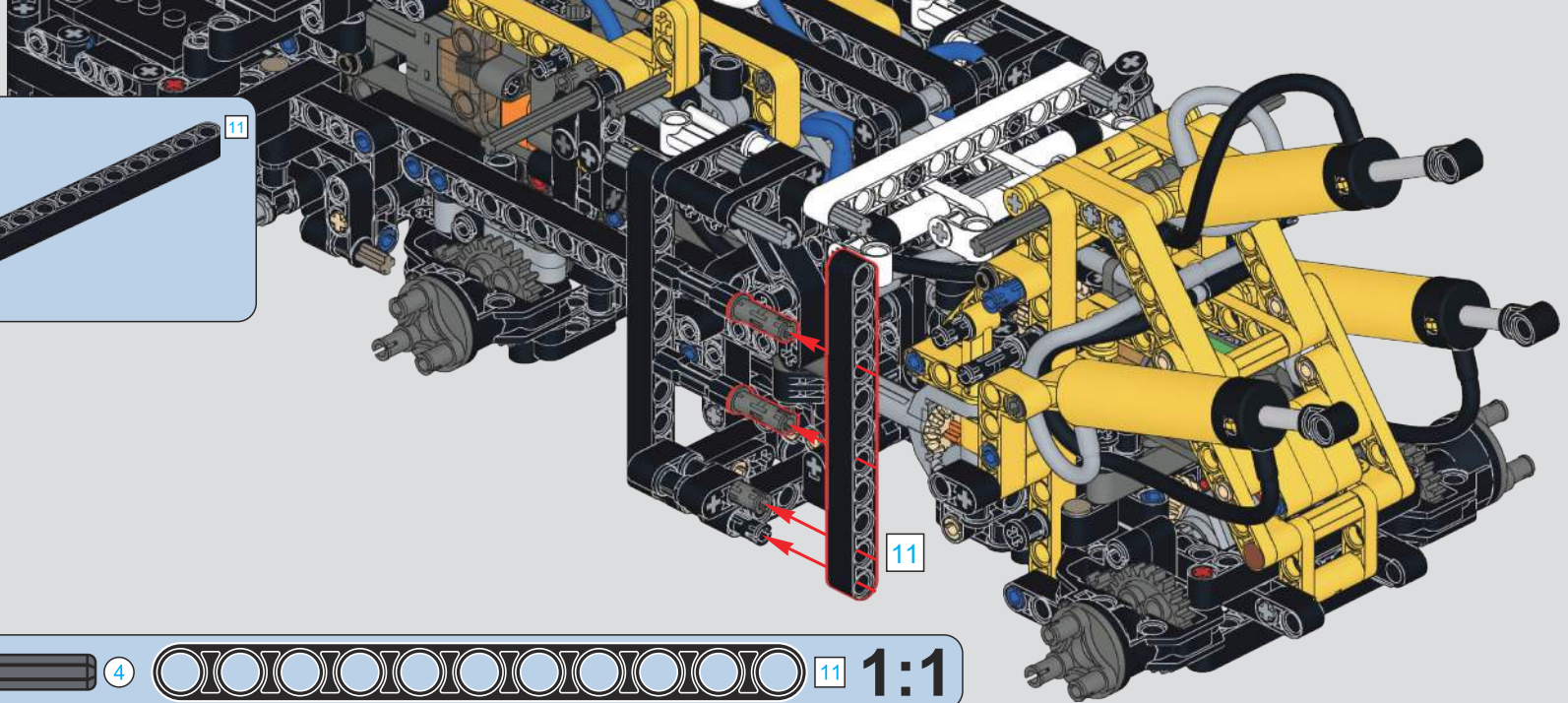

257

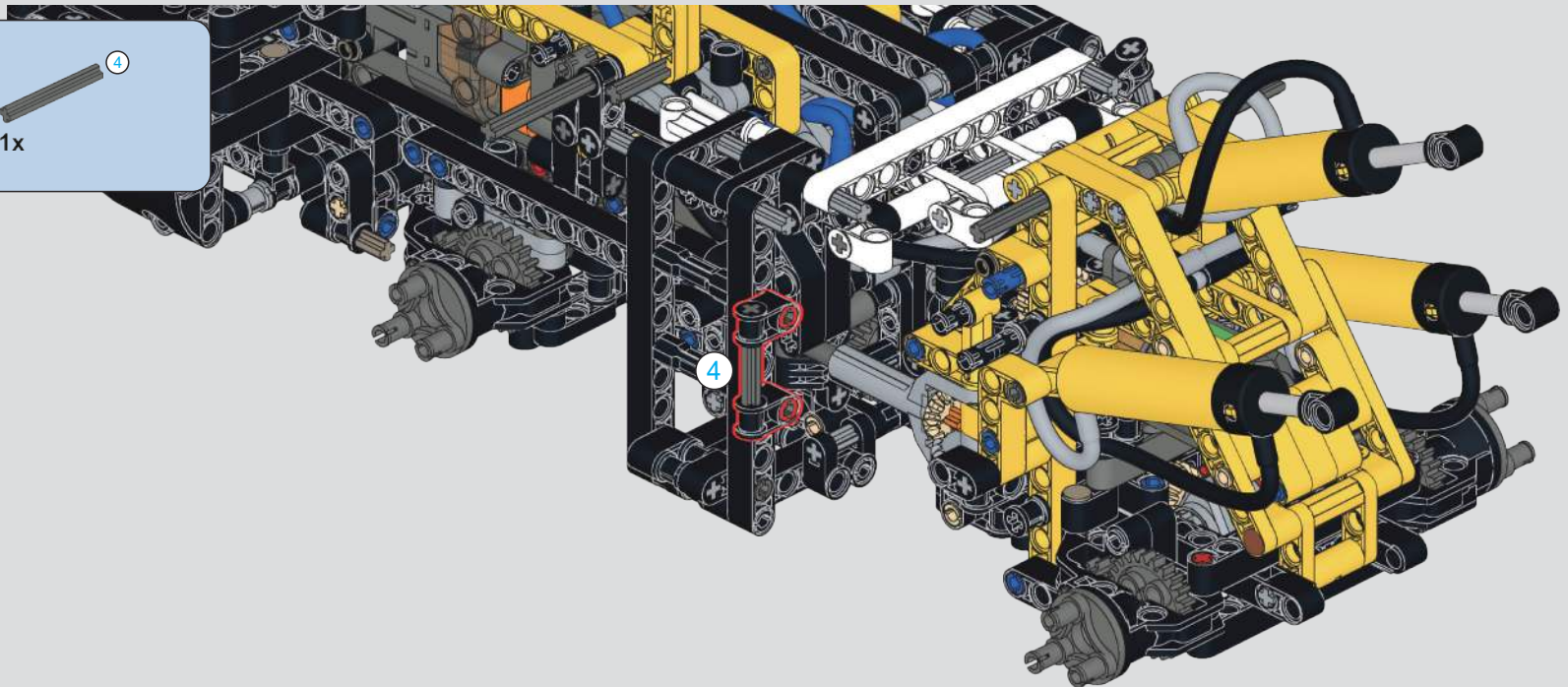

2x 2x

258

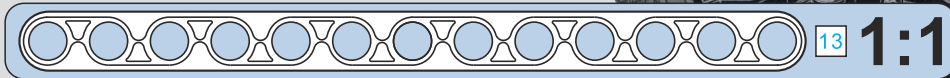
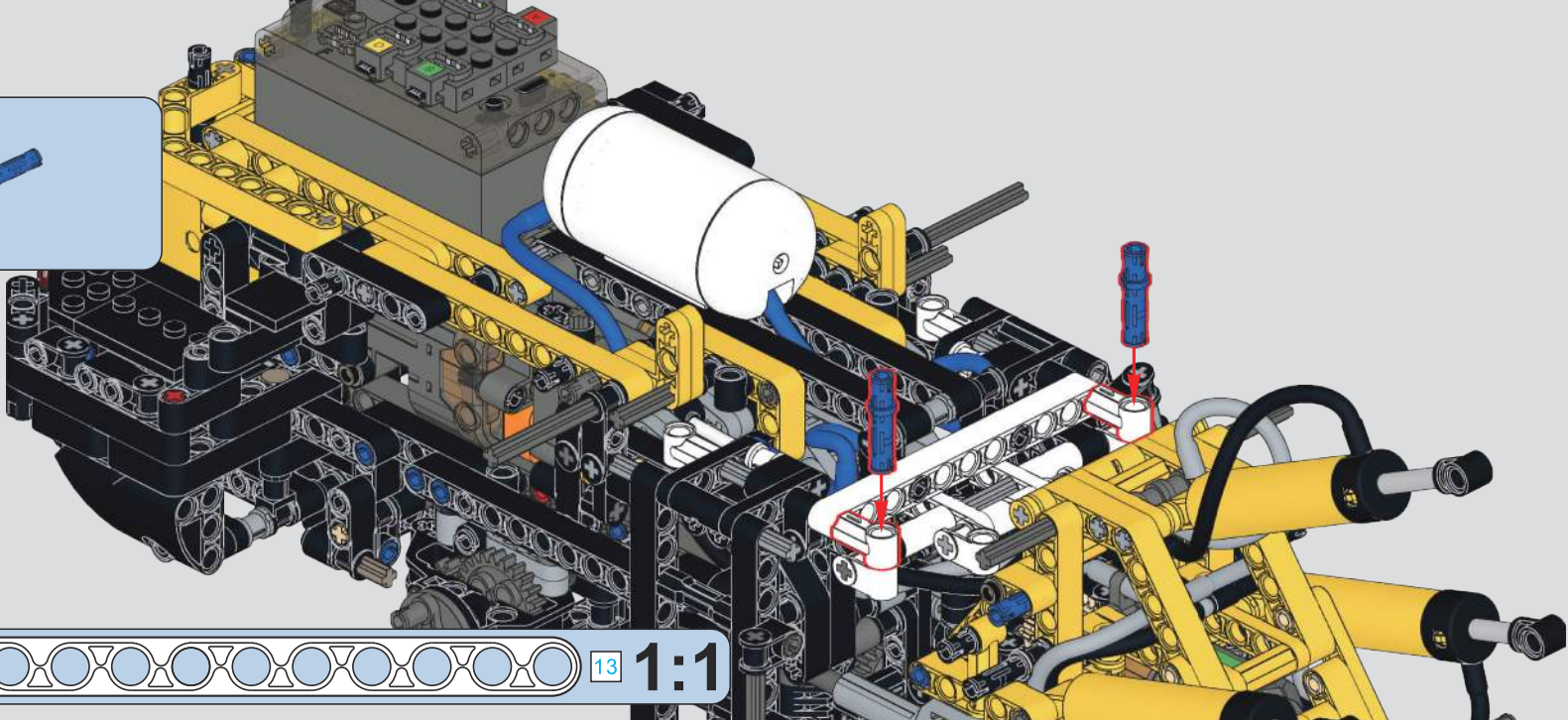

3x 1x 1x
1x 1x

259

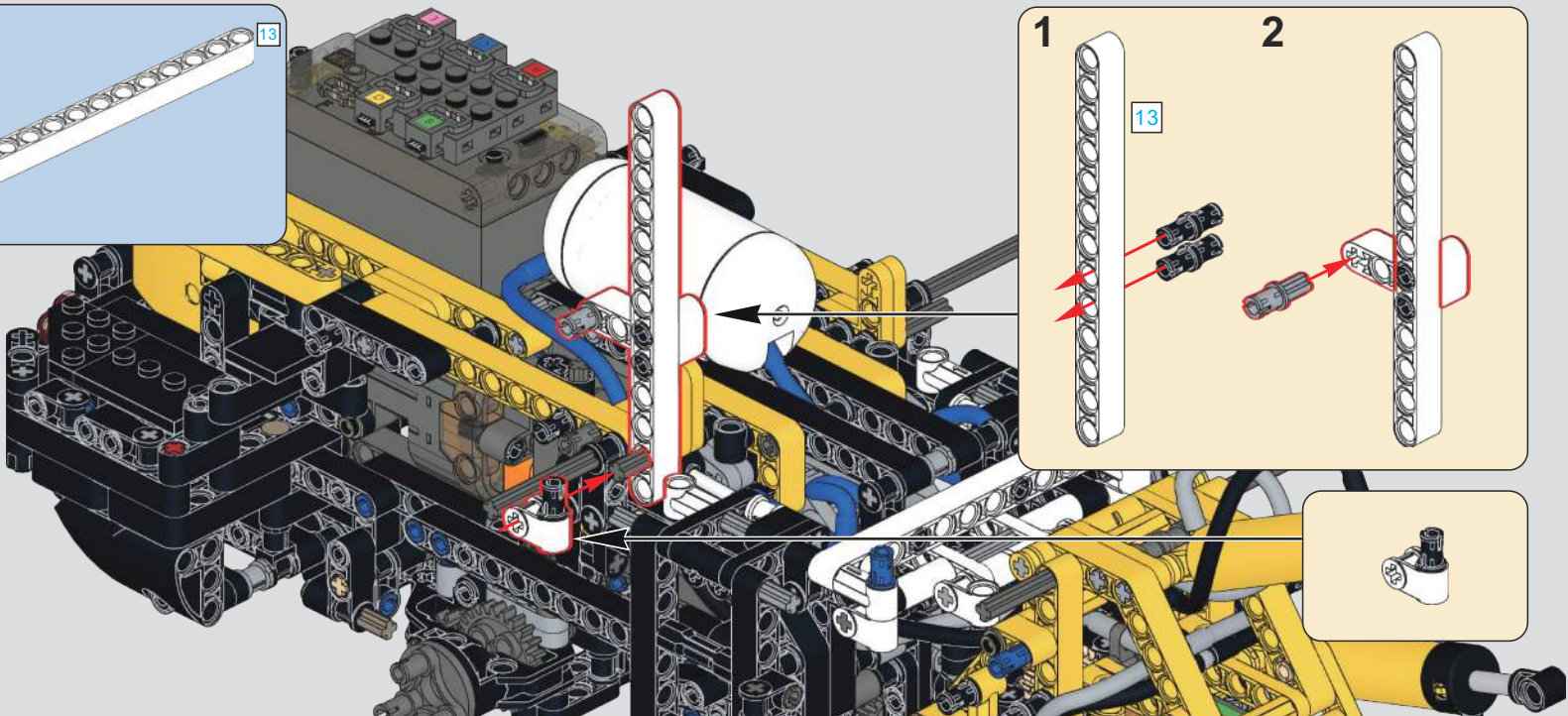



260

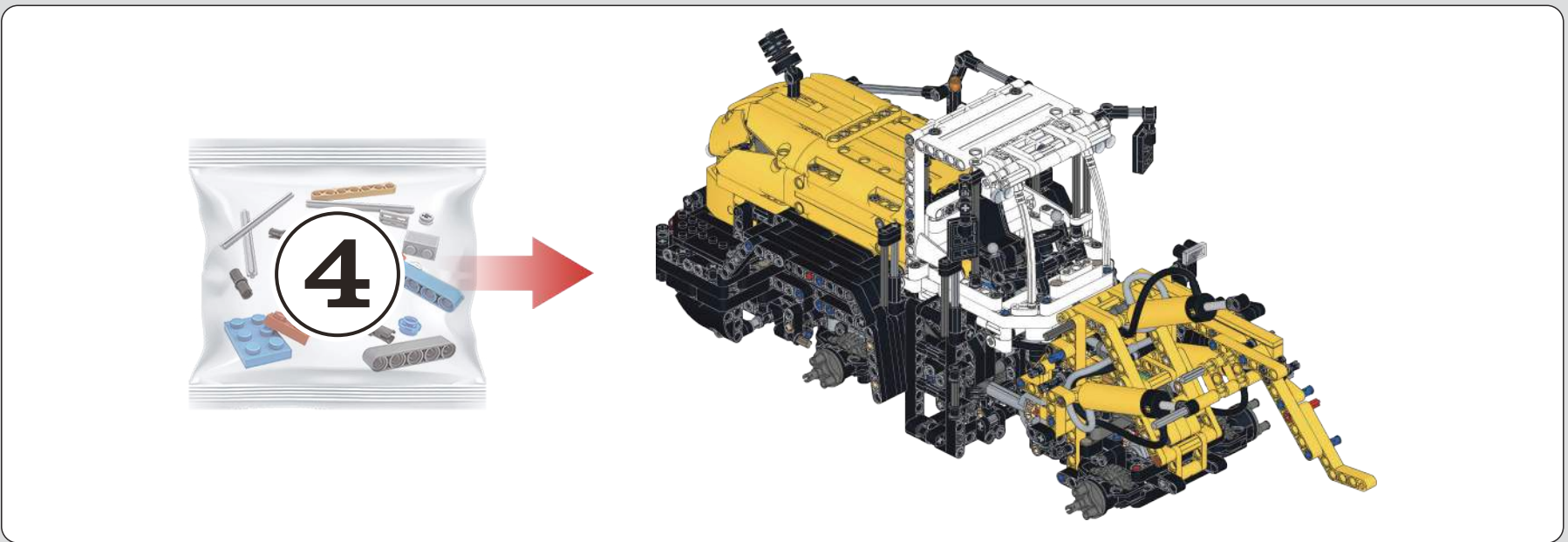
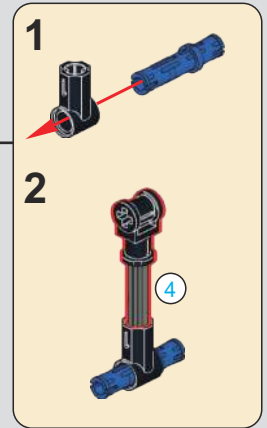
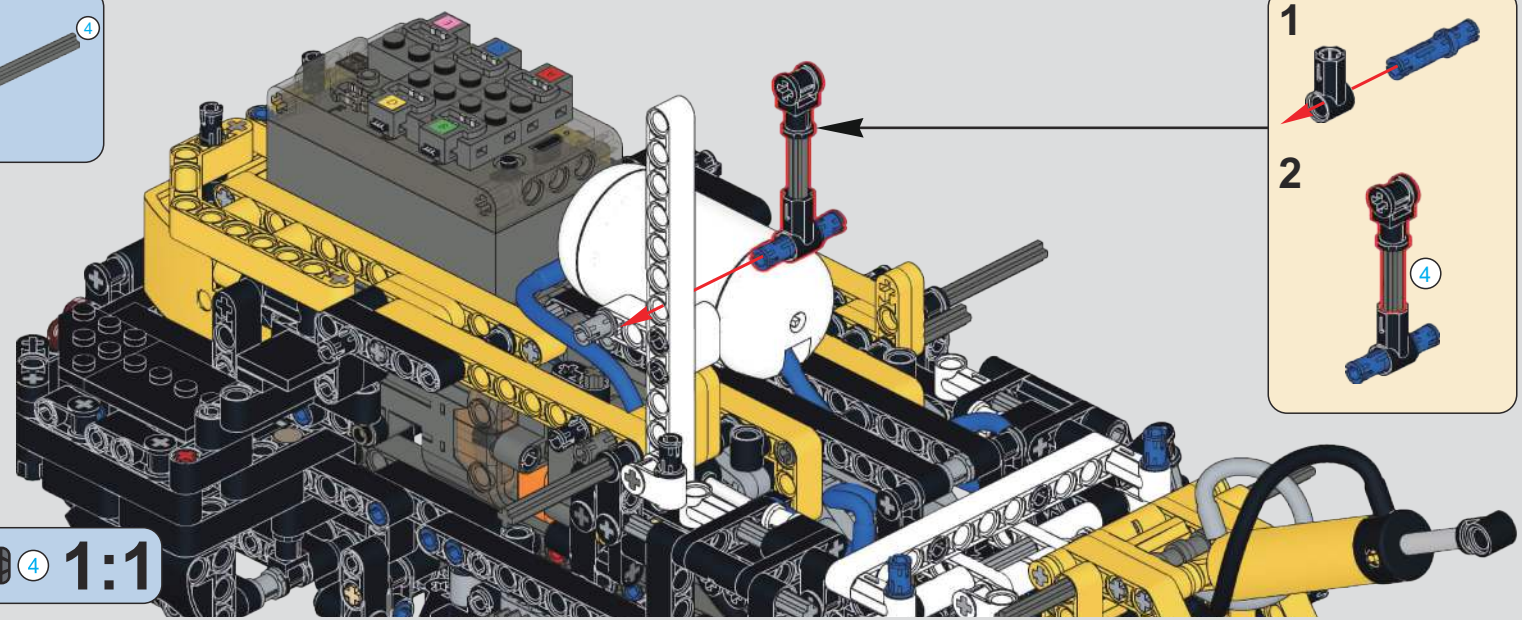

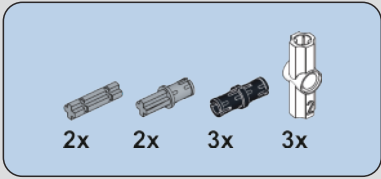

261

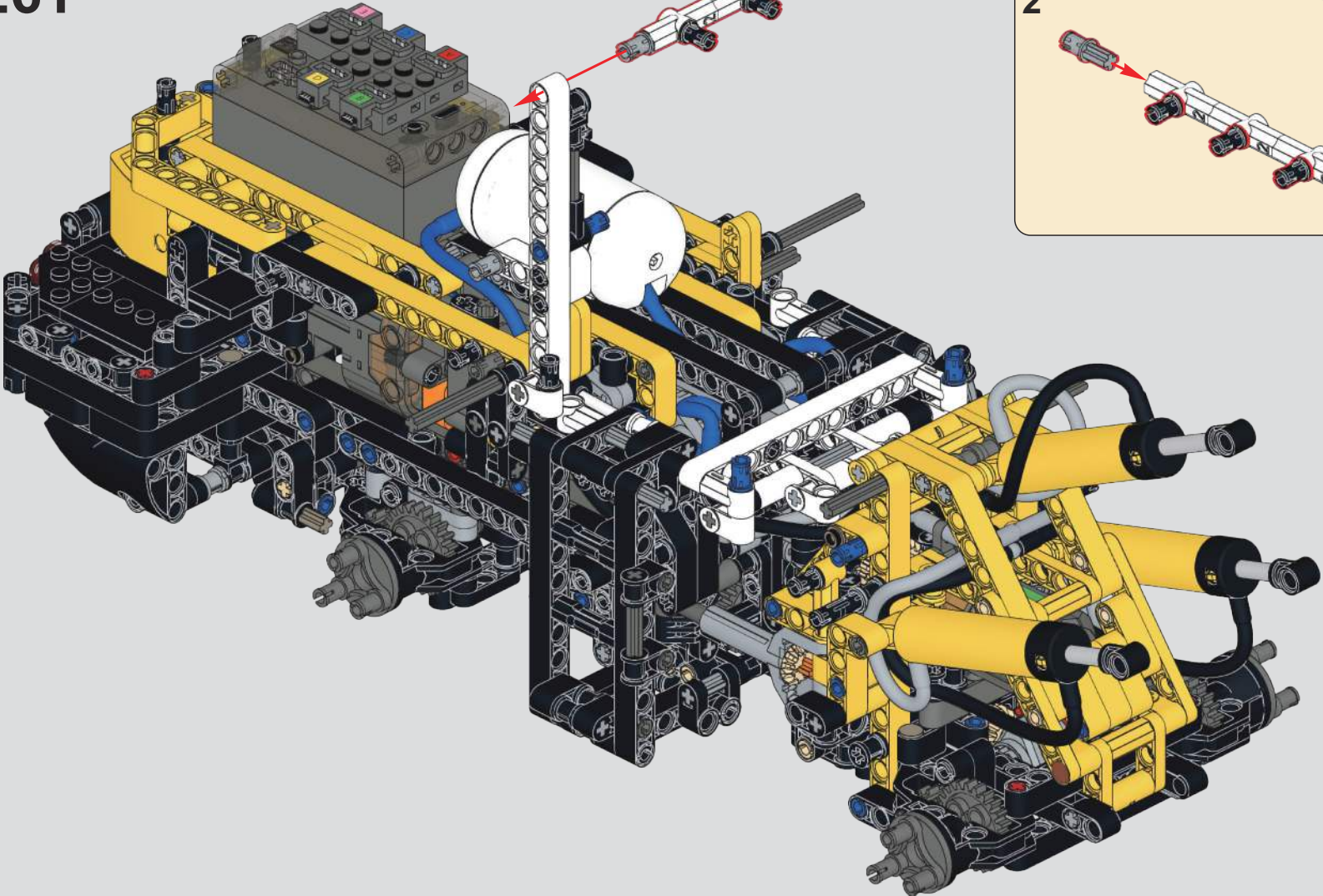
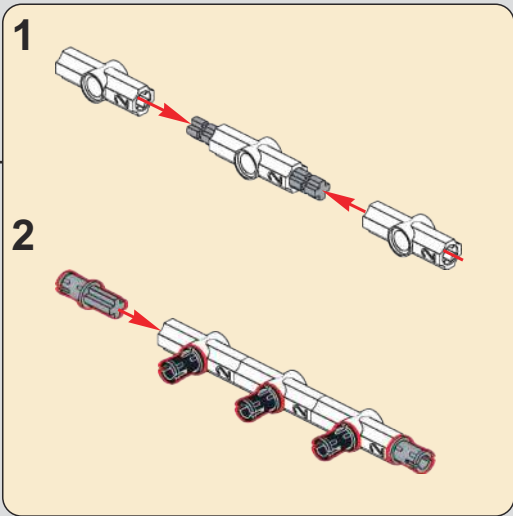

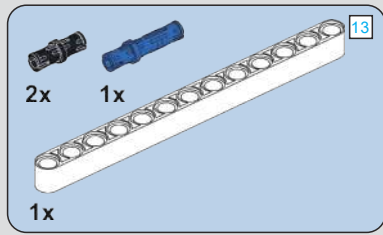

262

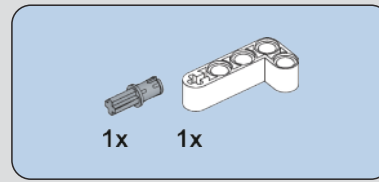
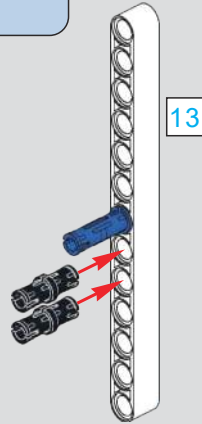

263

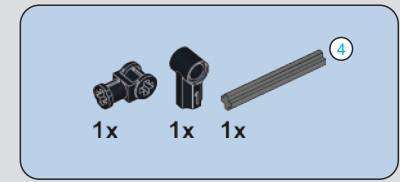
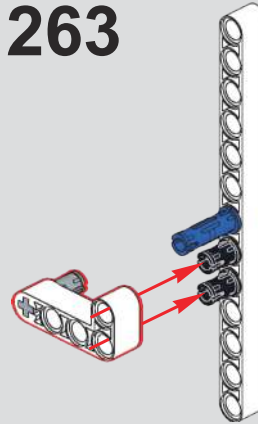

264

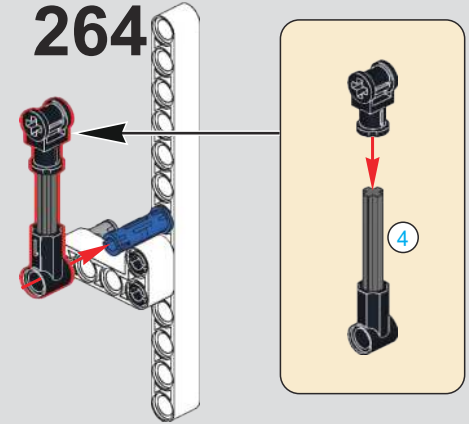

265

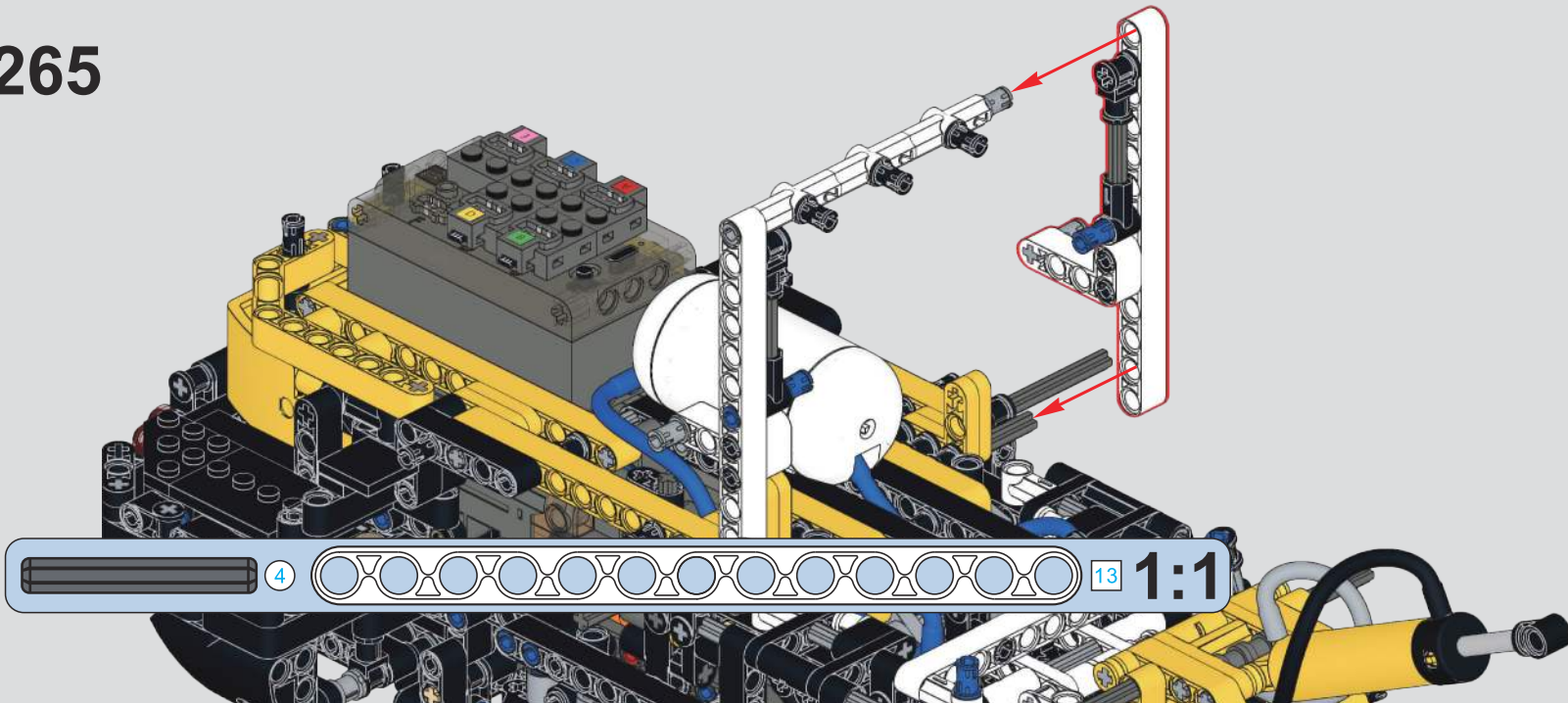



1x

266

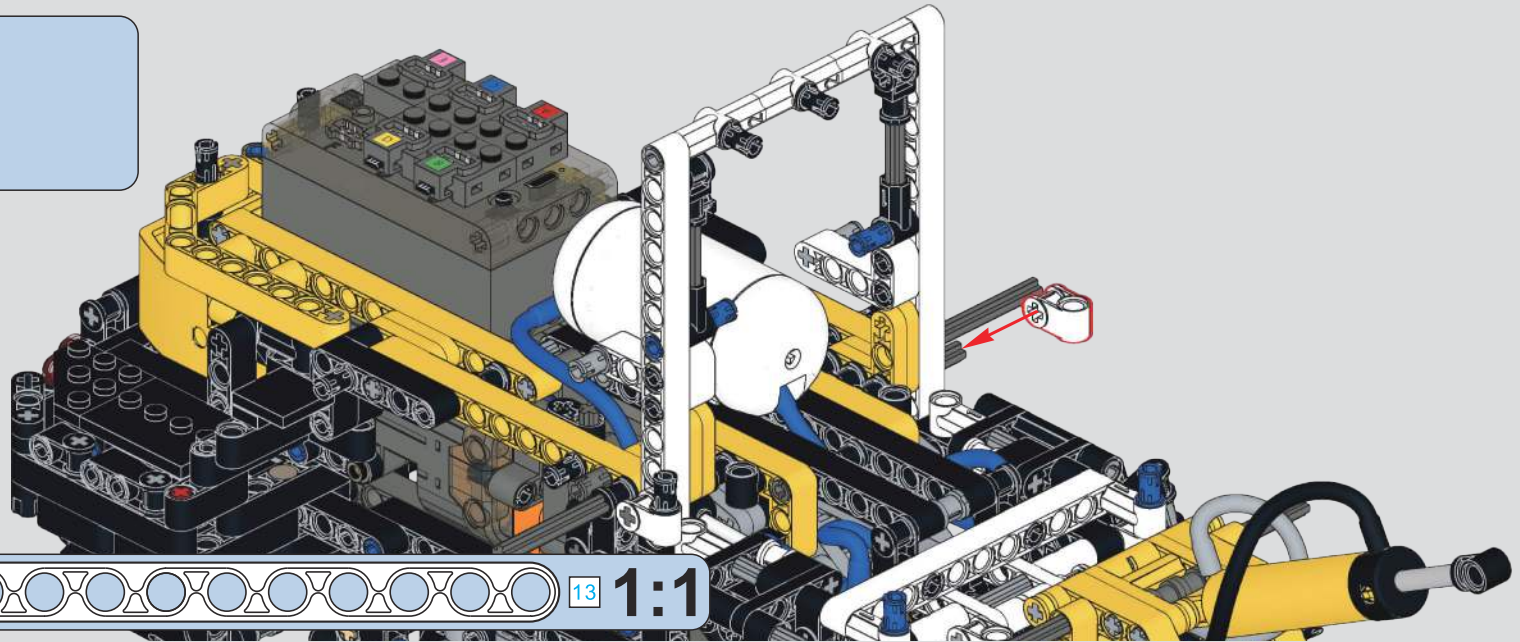

2x 2x 2x



2x 1x

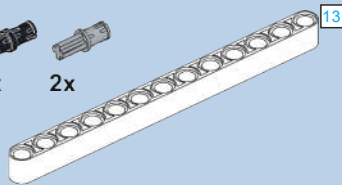

267

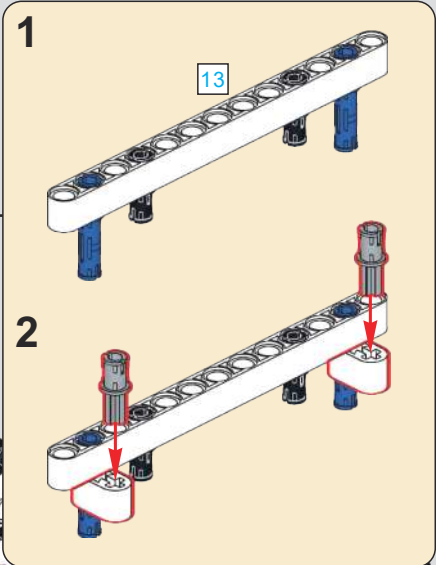
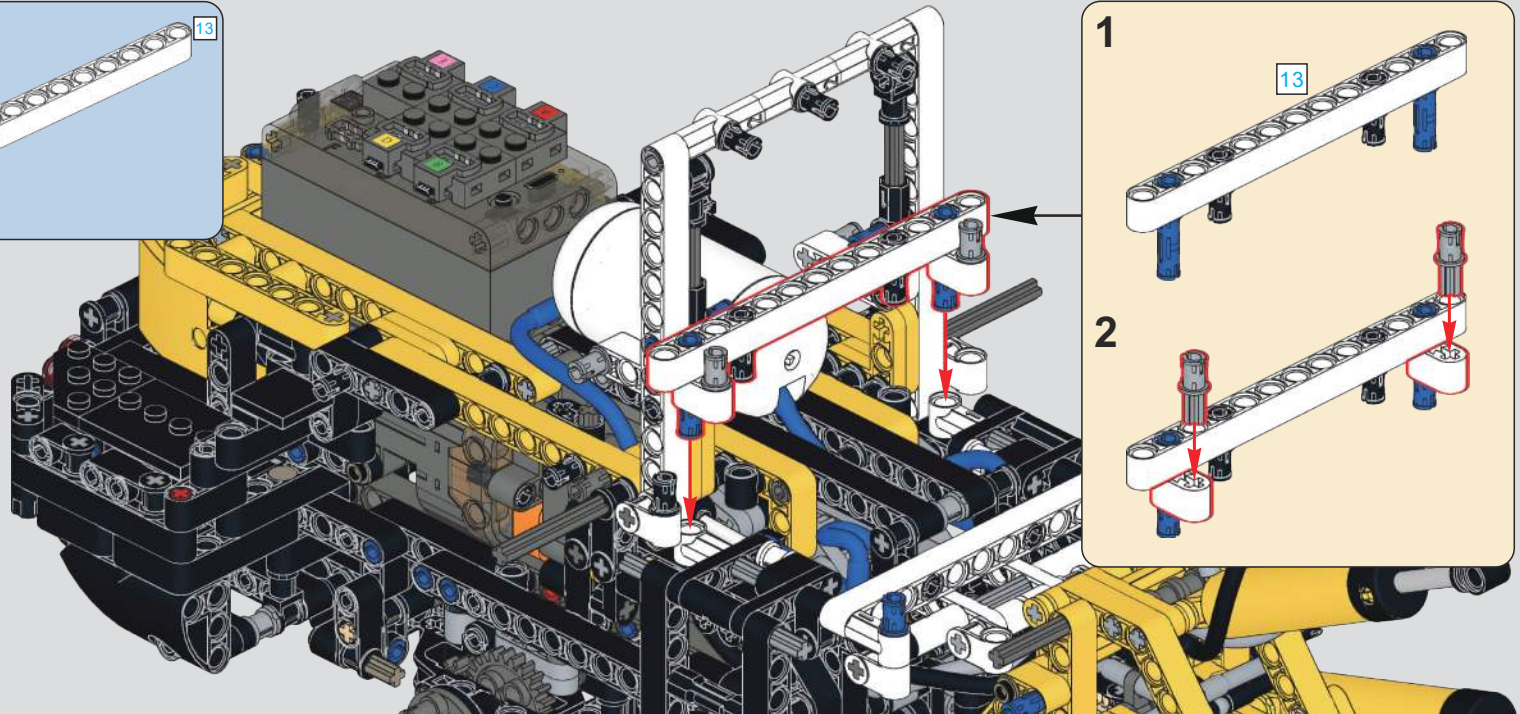

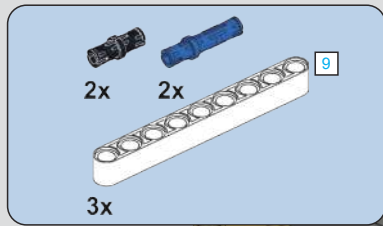

268

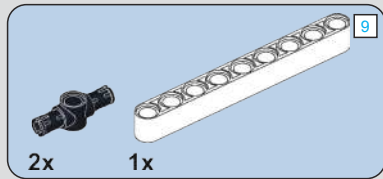
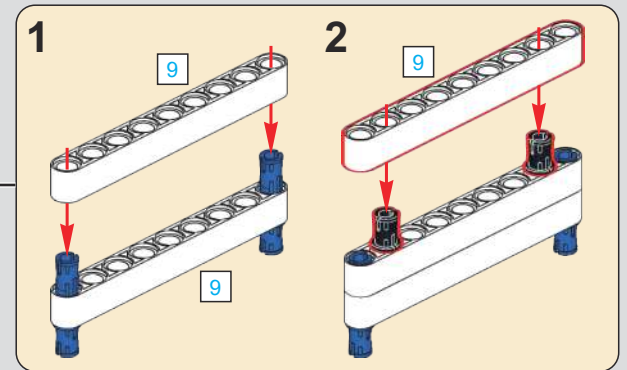
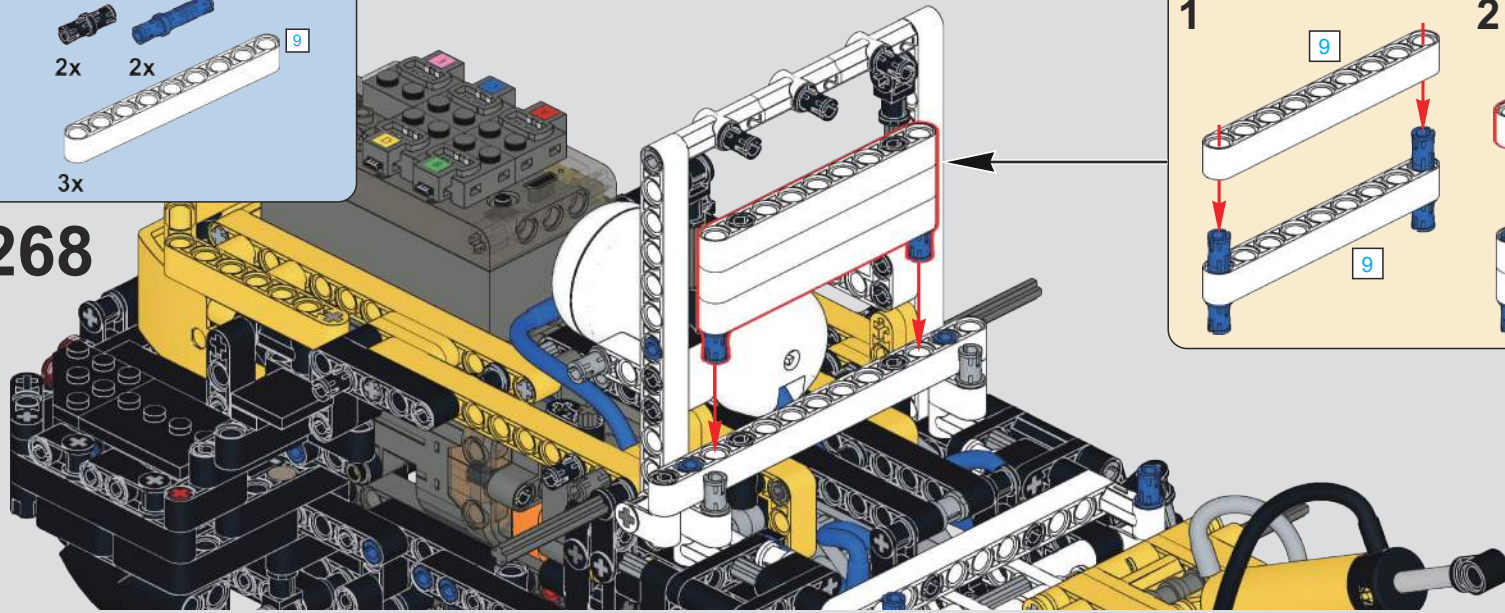

269

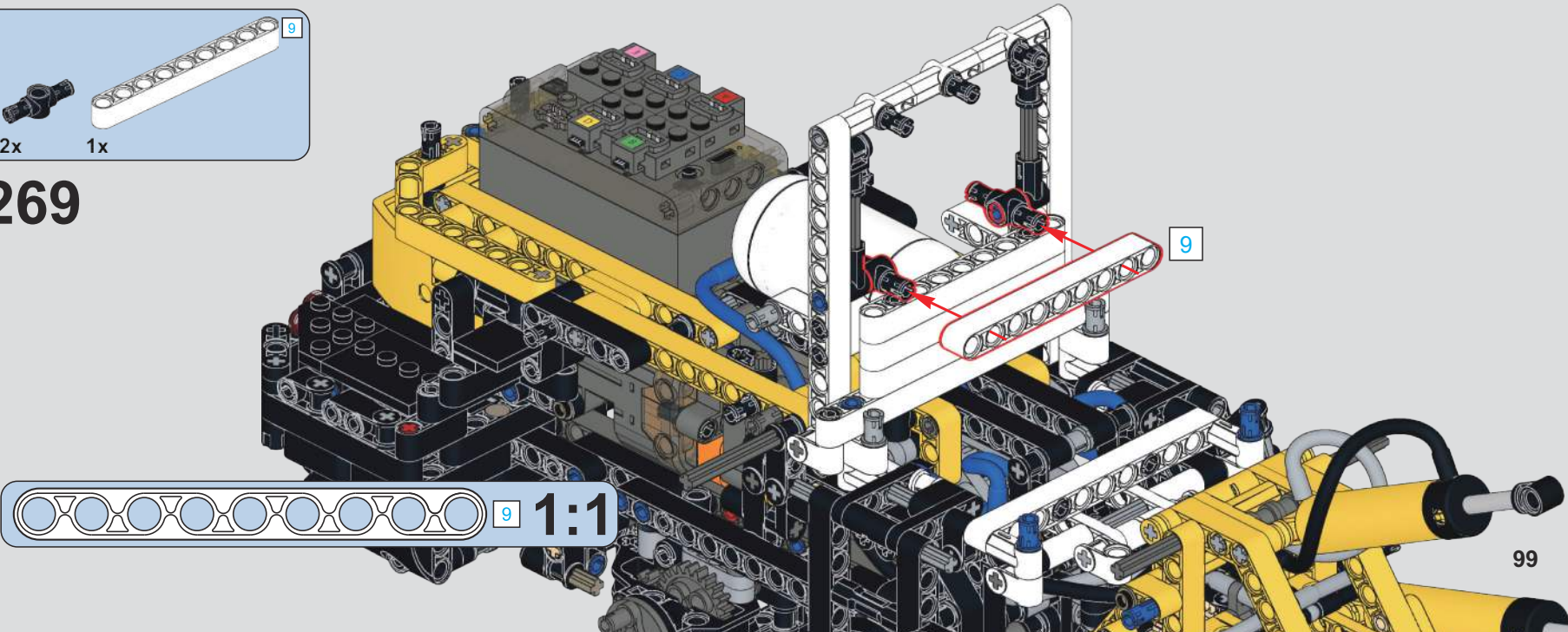

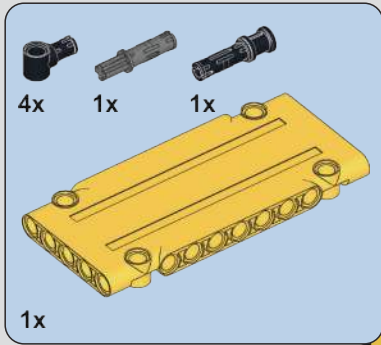

270

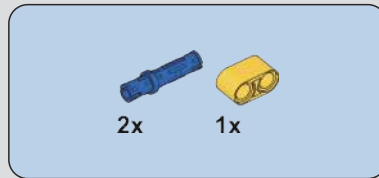
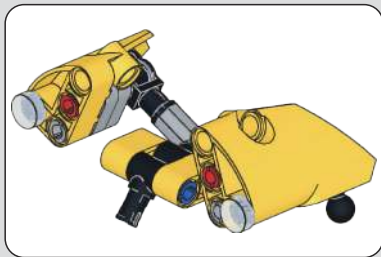
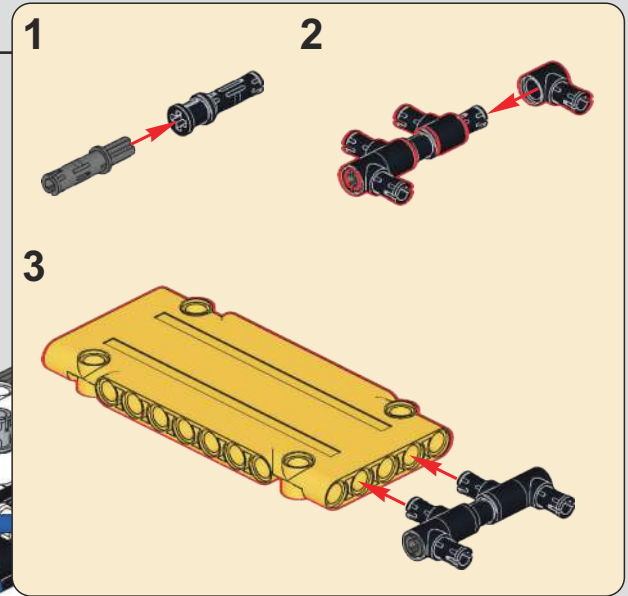
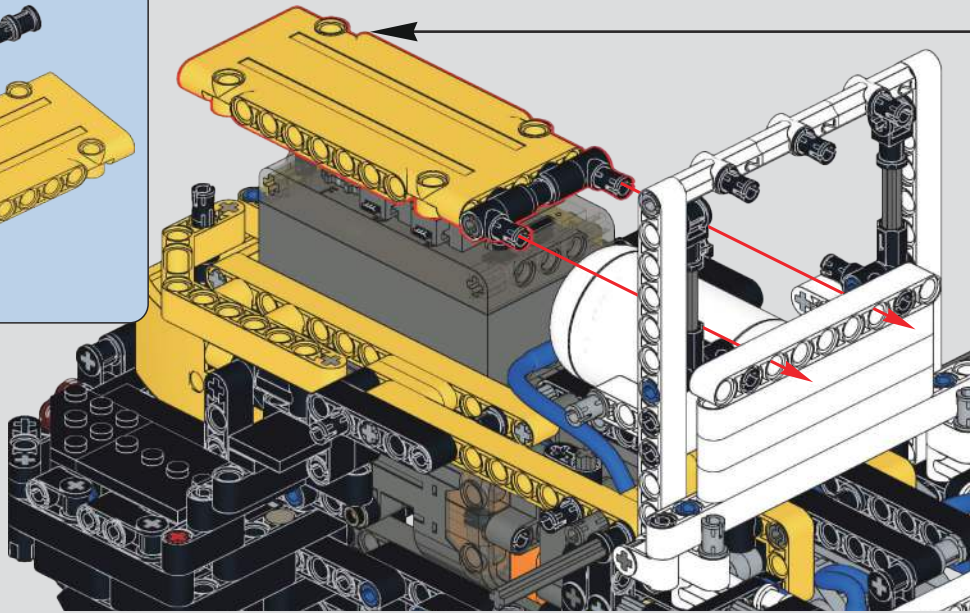

271

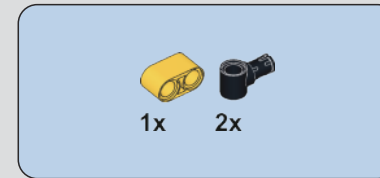
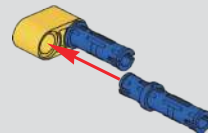

272

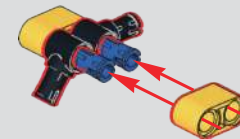

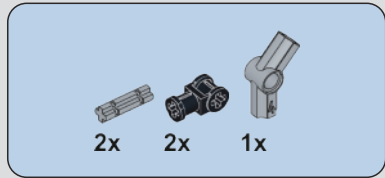

273

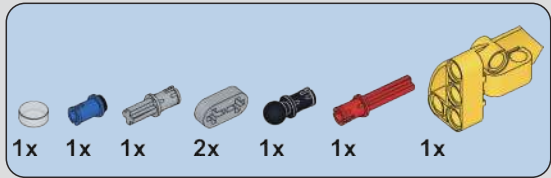
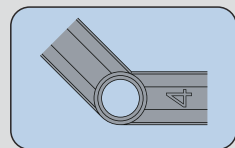
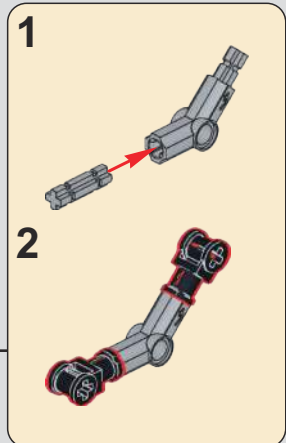
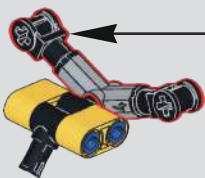

274

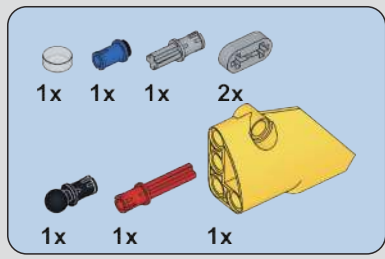
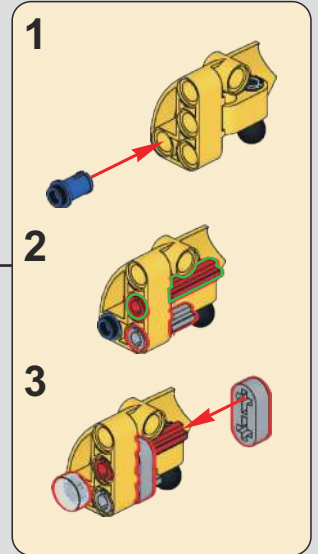
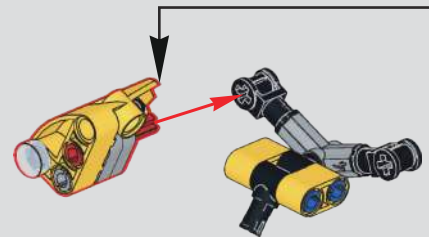

275

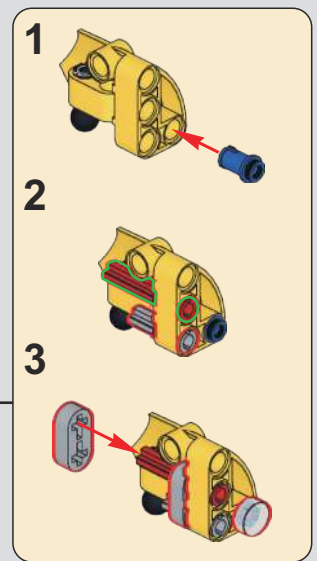
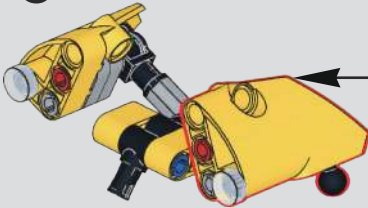

276

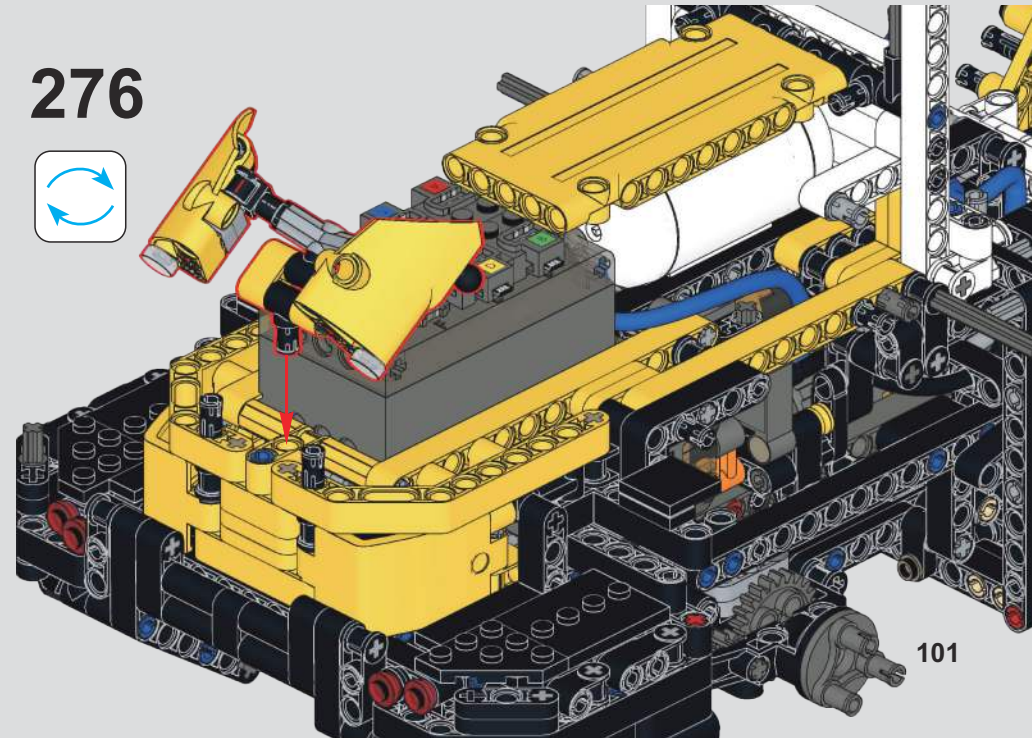

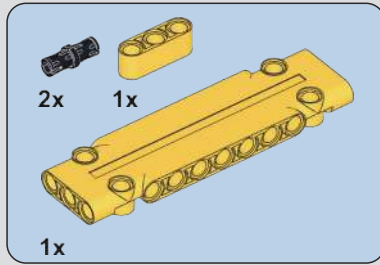
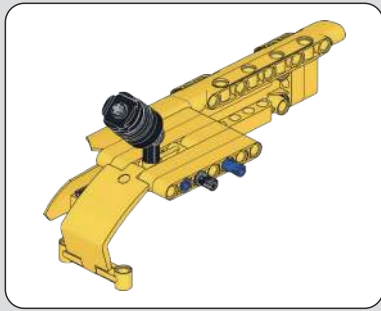

277

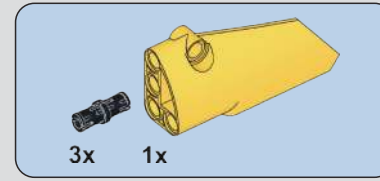
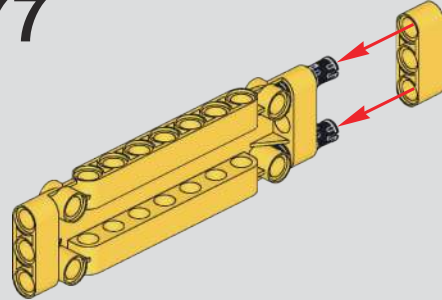

278

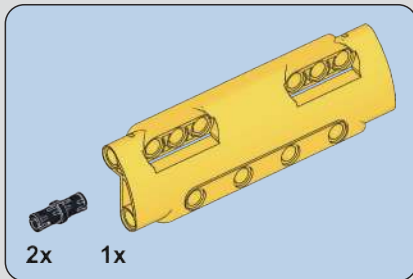
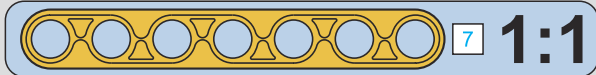
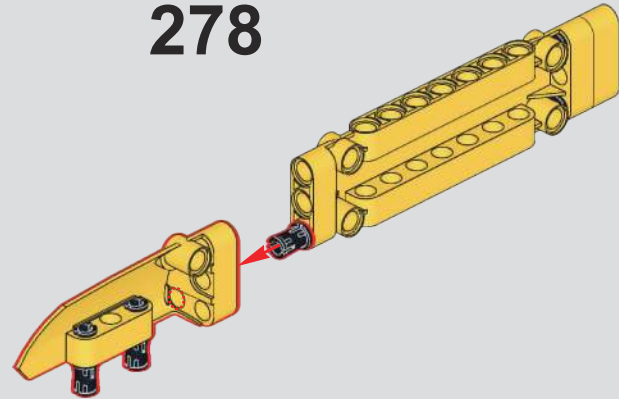

279

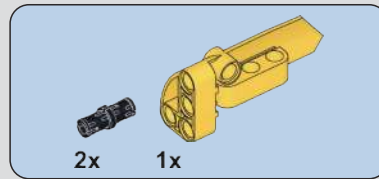
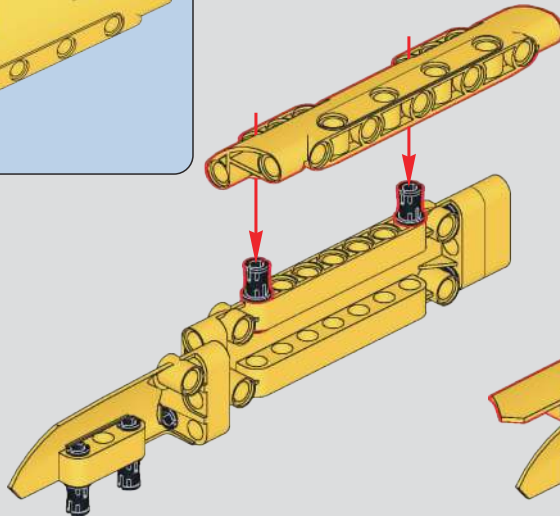

280

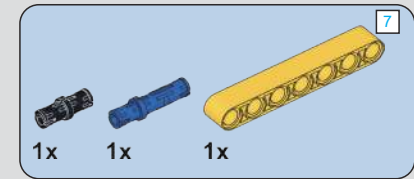
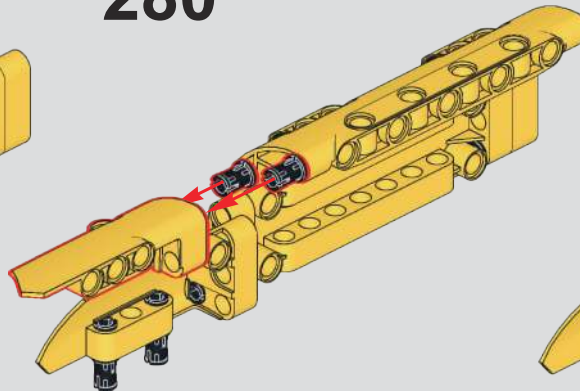

281

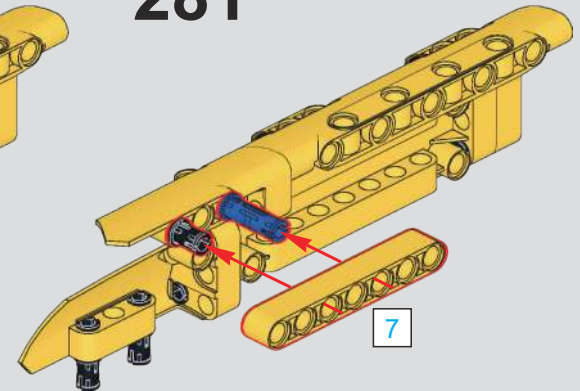

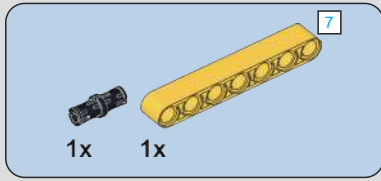

282

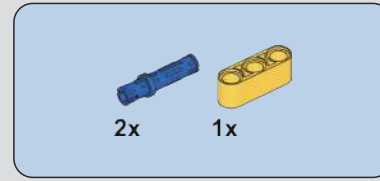
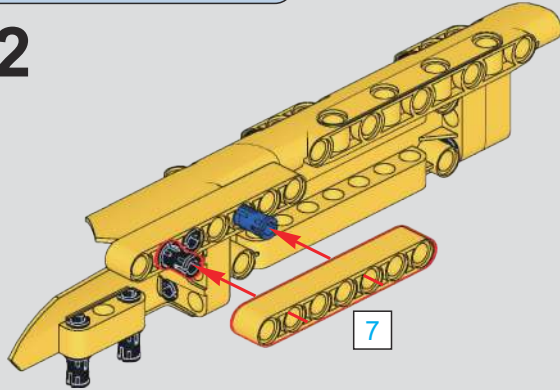

283

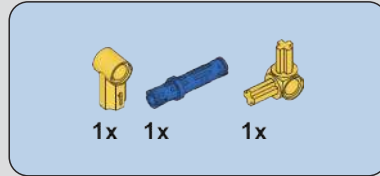
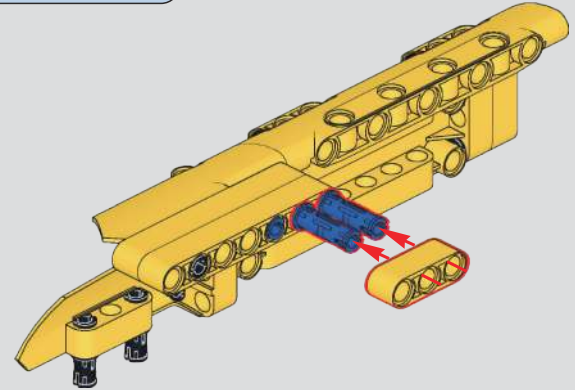

284

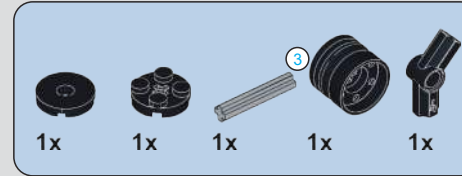
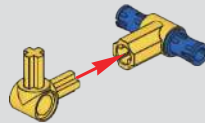

285

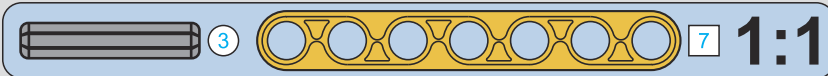
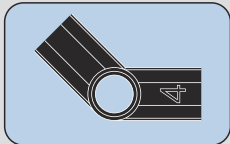
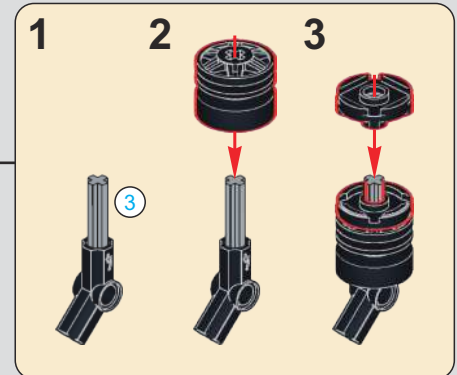

286

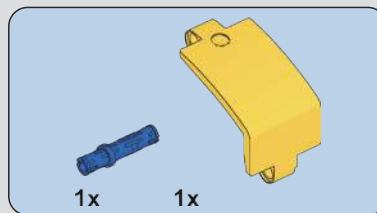
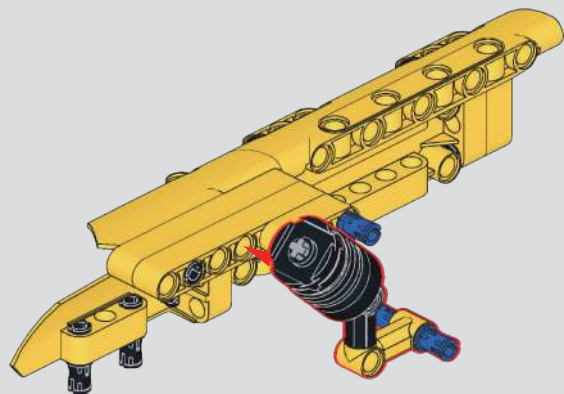

287

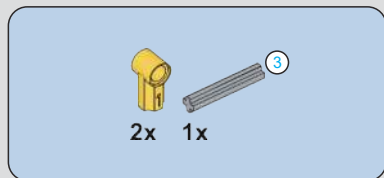
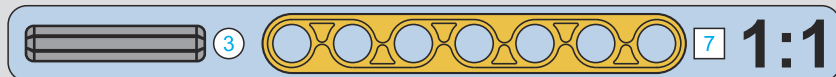
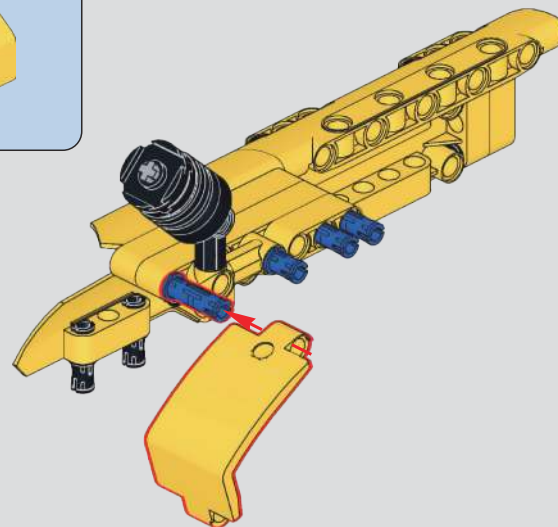

288

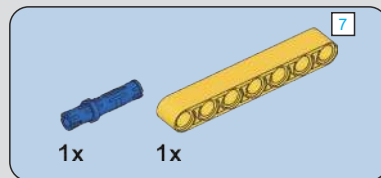
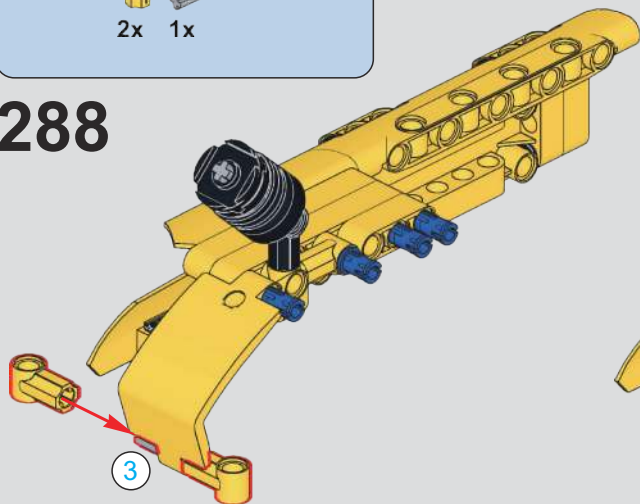

289

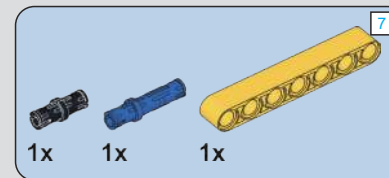
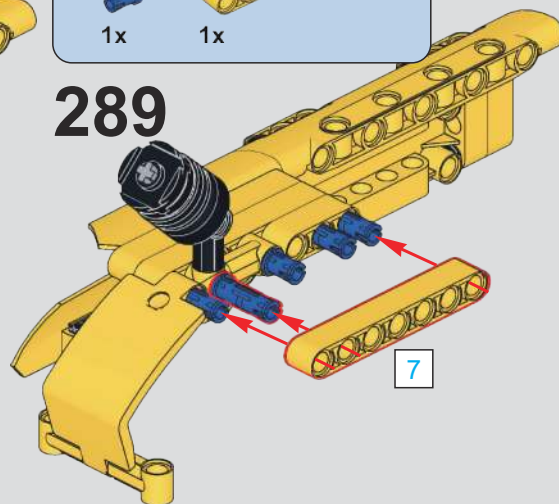

290

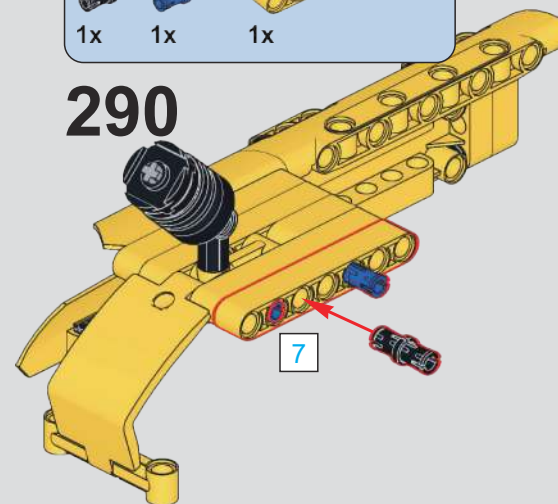

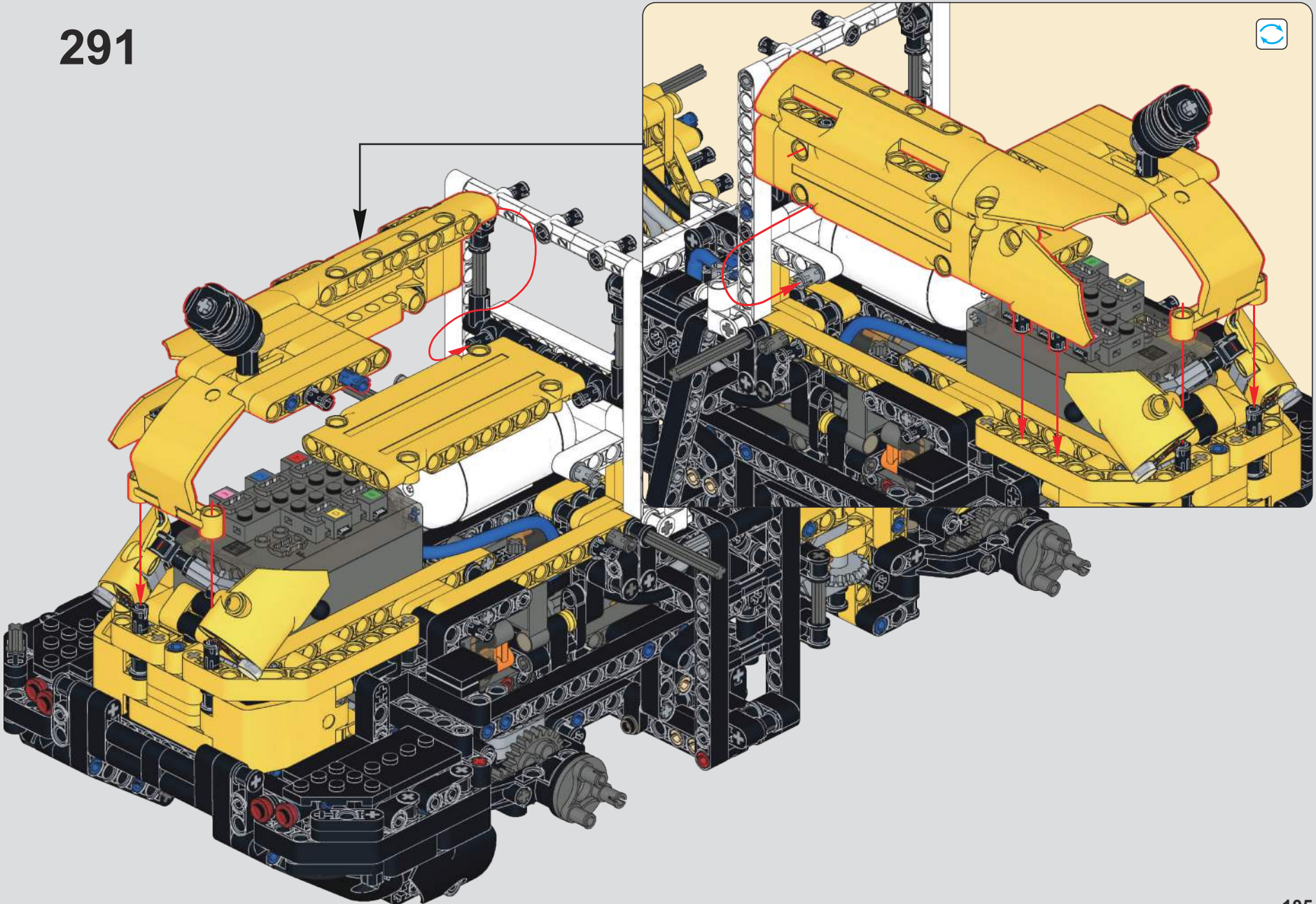

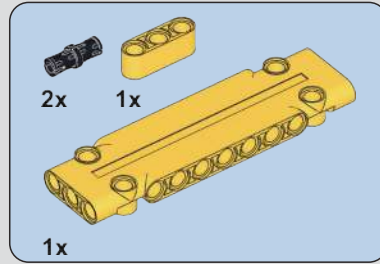
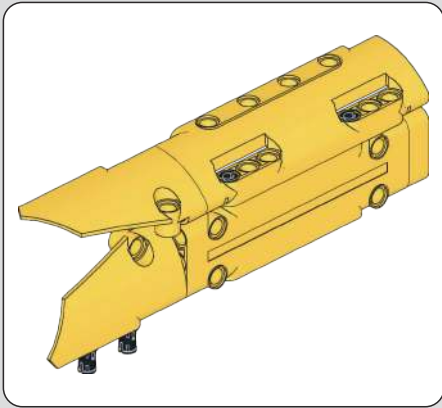

292

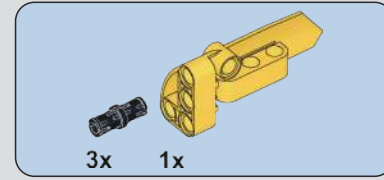
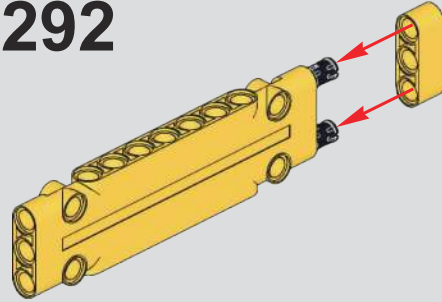

293

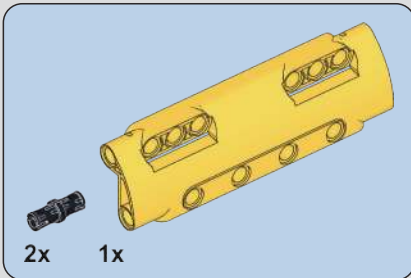
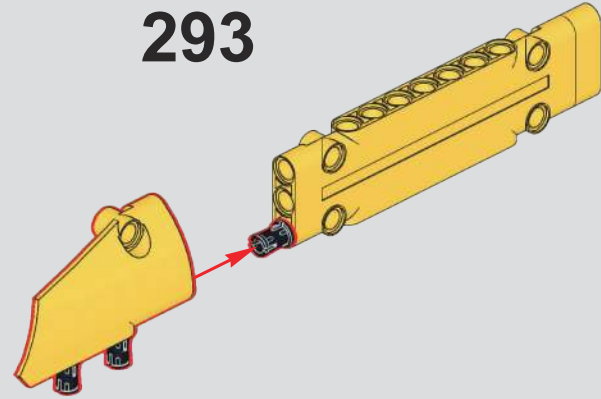

294

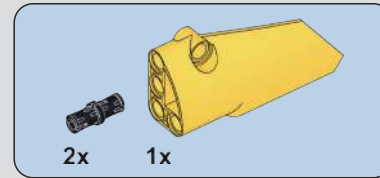
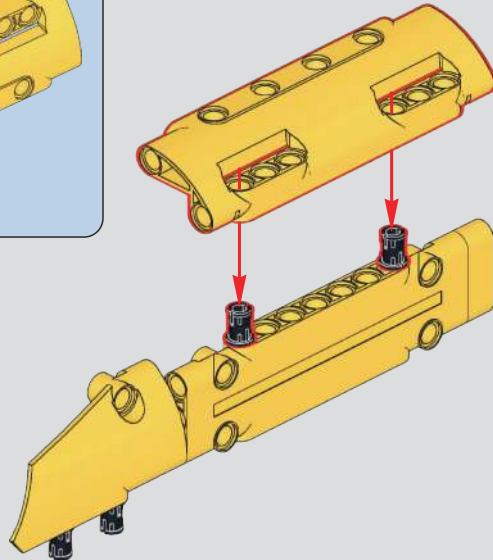

295

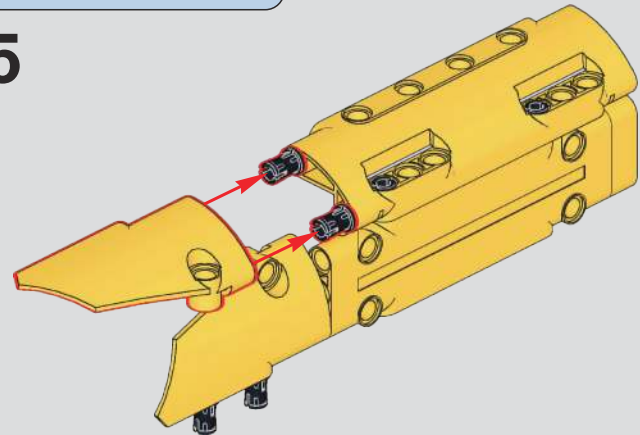

296

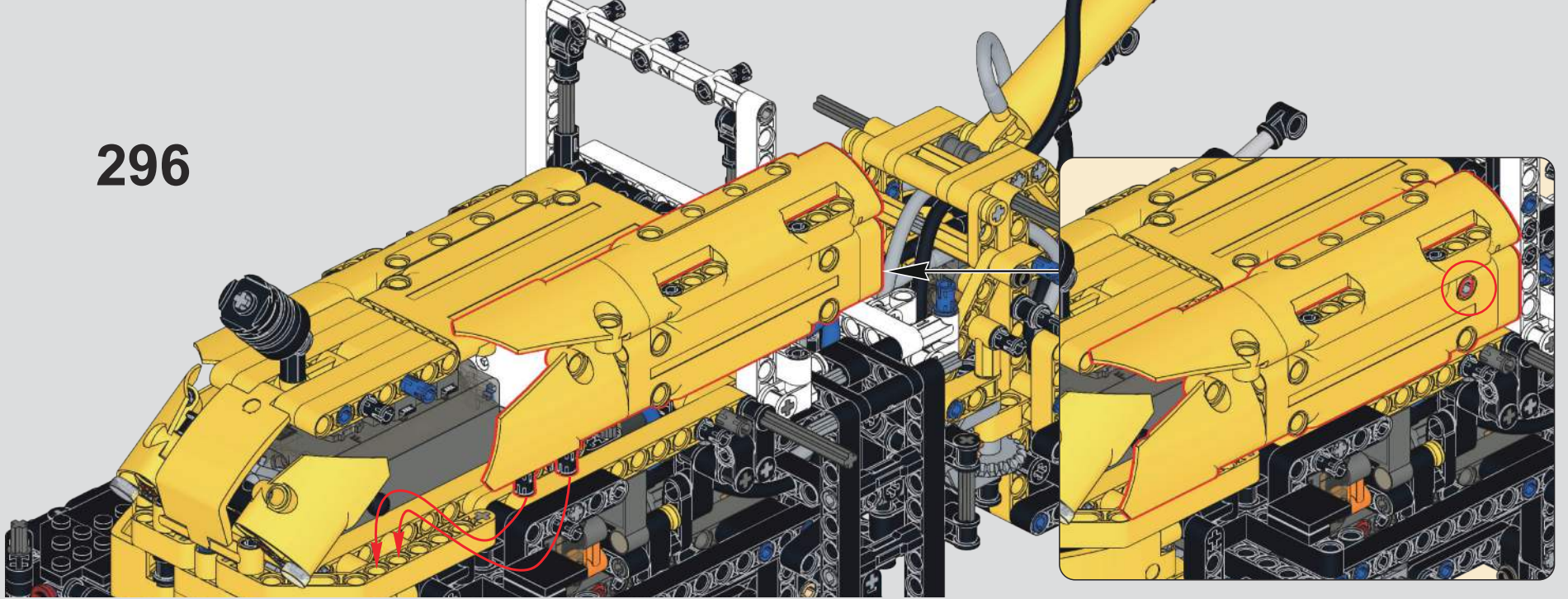

(光滑栓)(Technic Pin without Friction)

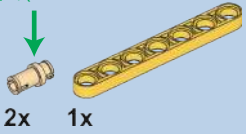

297

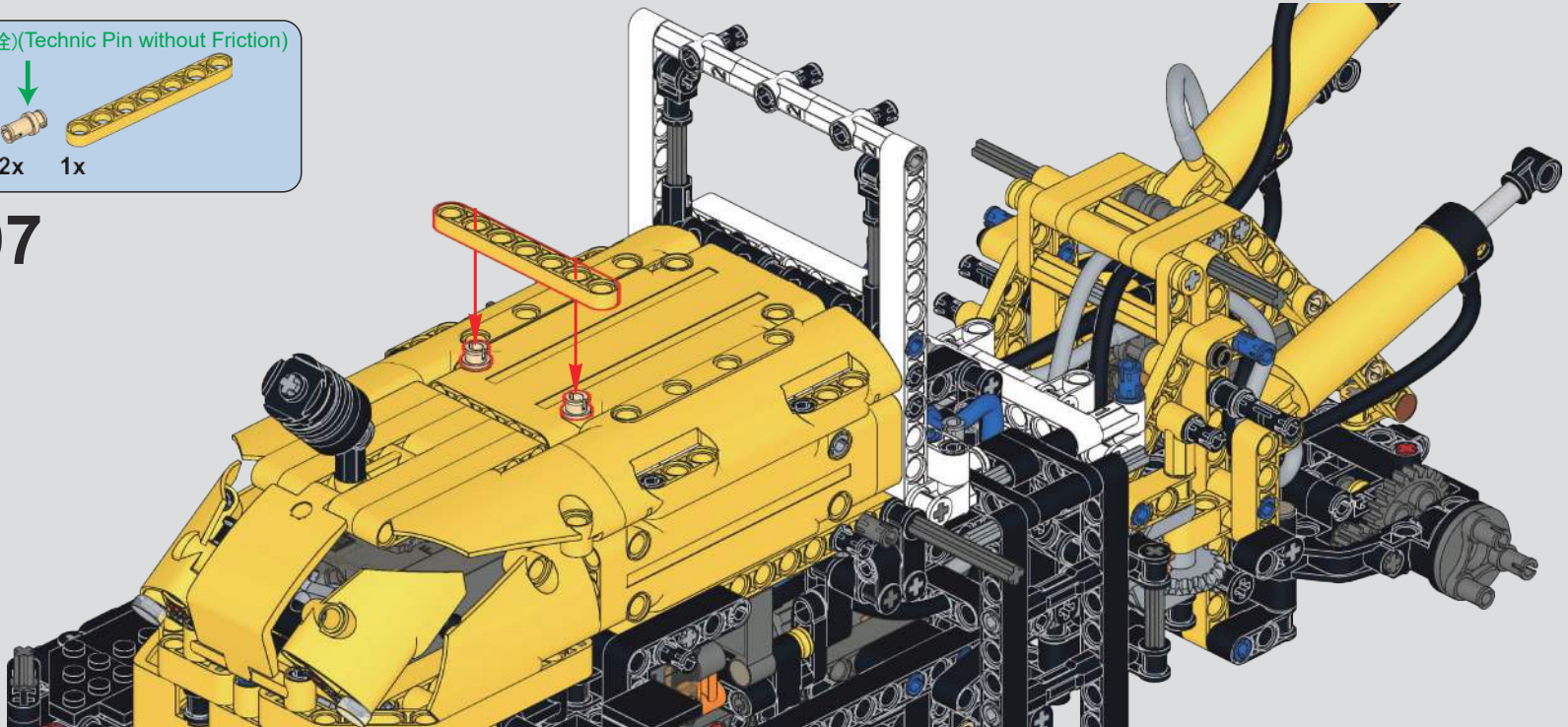

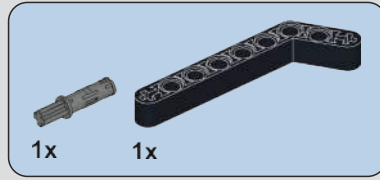
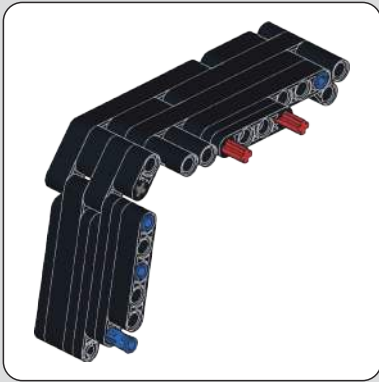

298

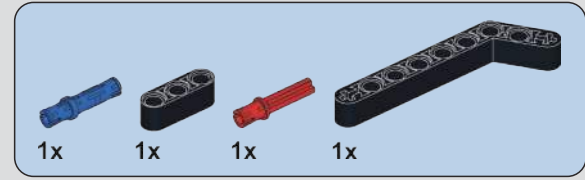

299

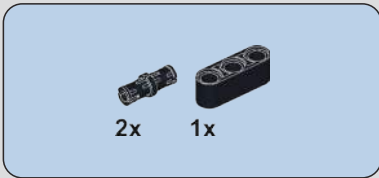
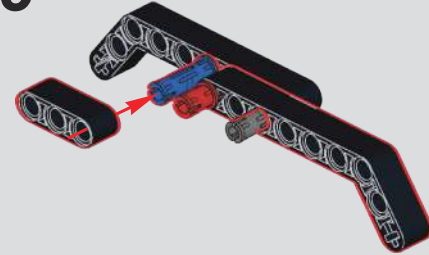

300

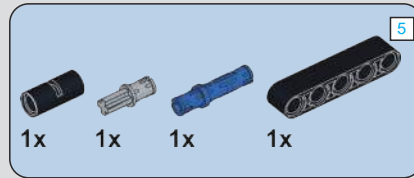
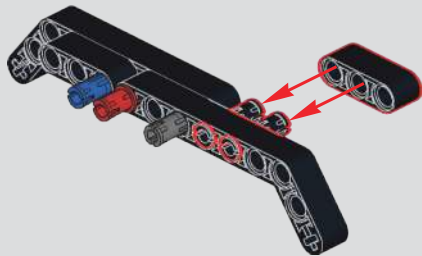

301

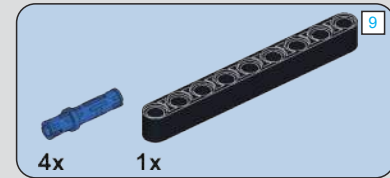
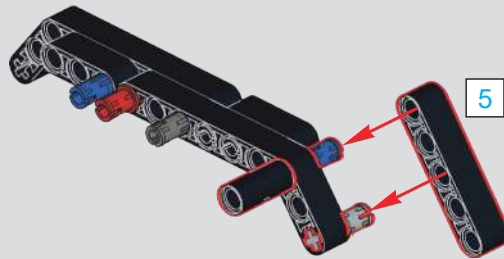

302

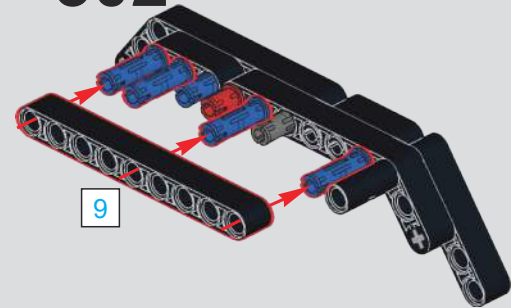

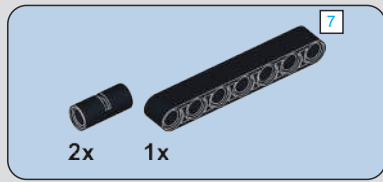

303

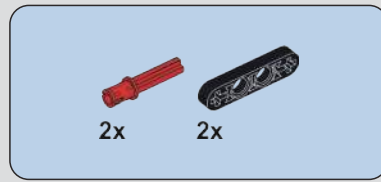
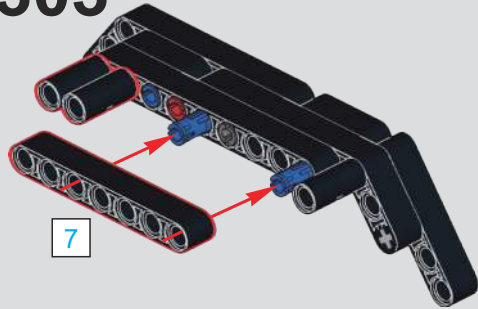

304

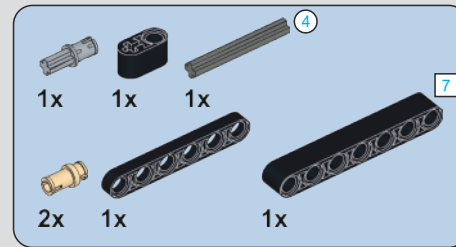
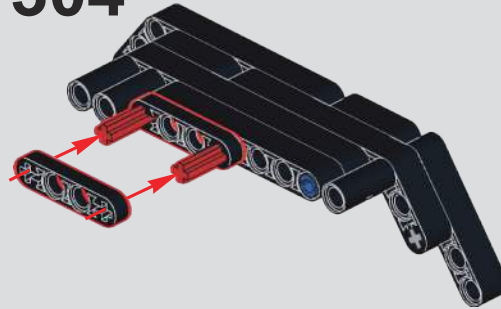

305

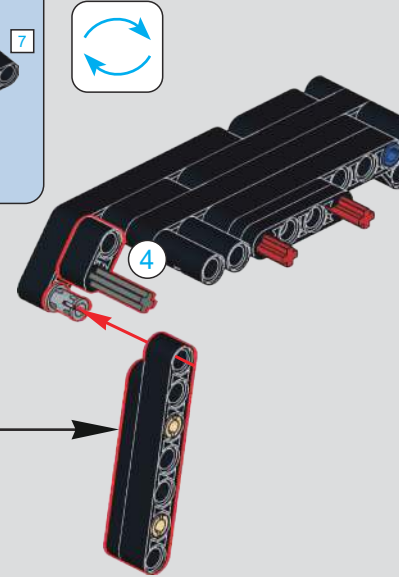
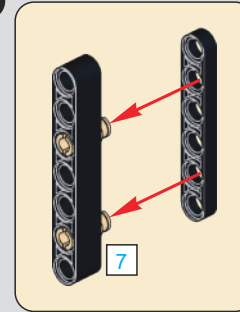

306

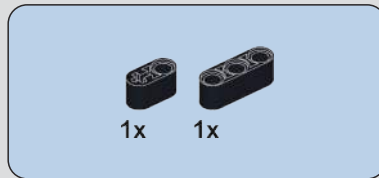
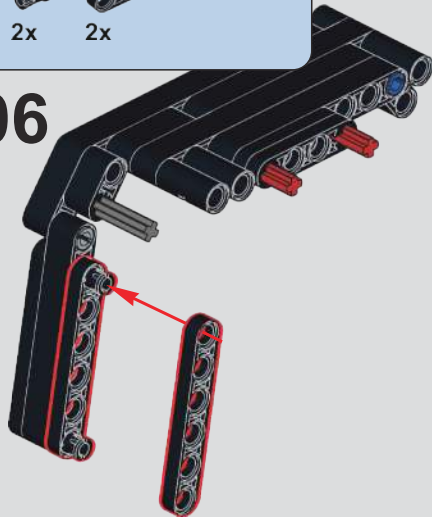

307

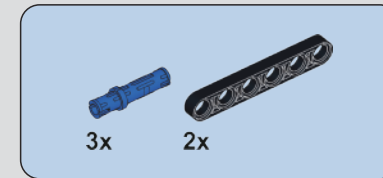
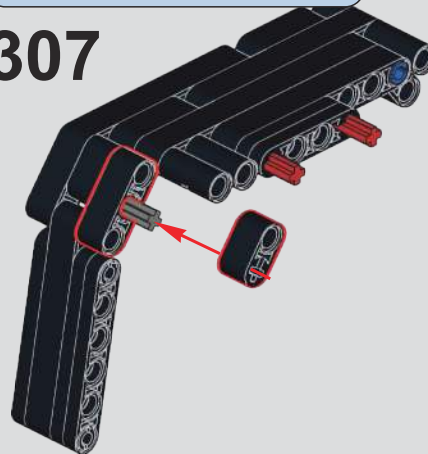

308

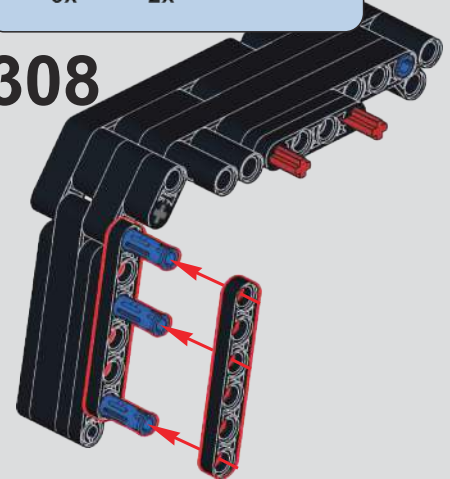

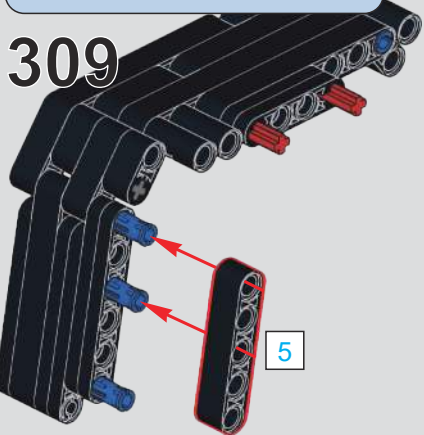
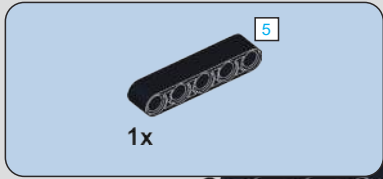

310

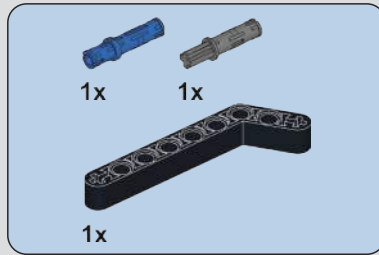
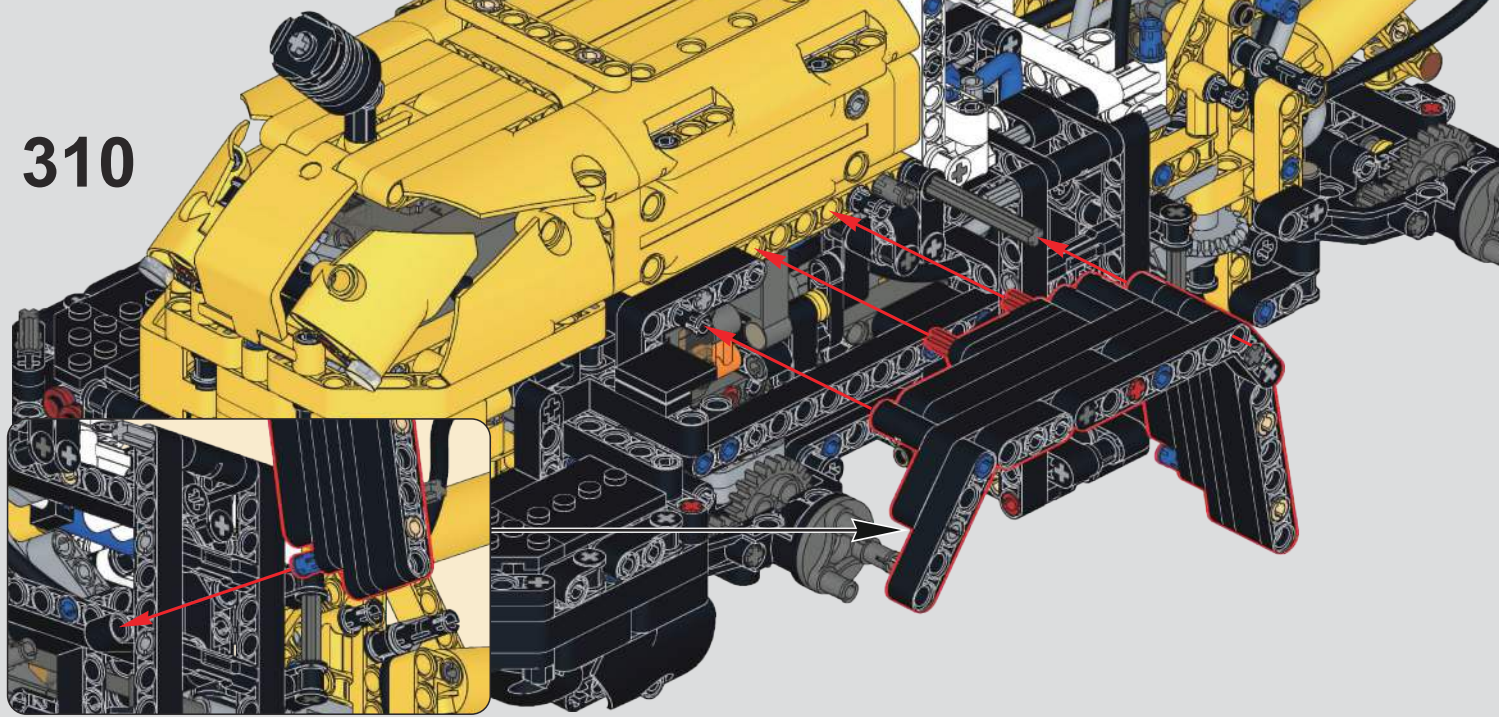

311

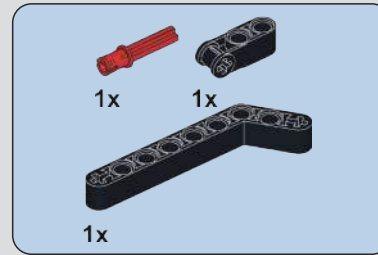
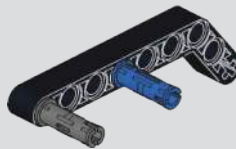

312

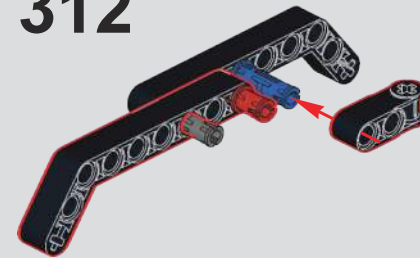

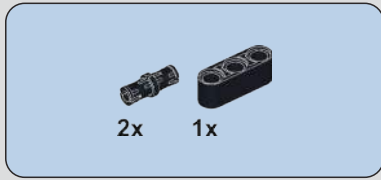

313

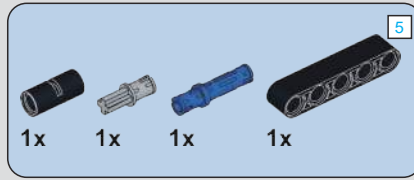
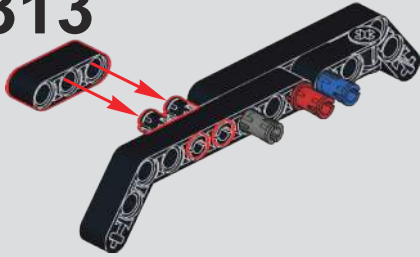

314

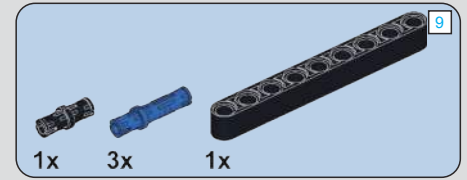
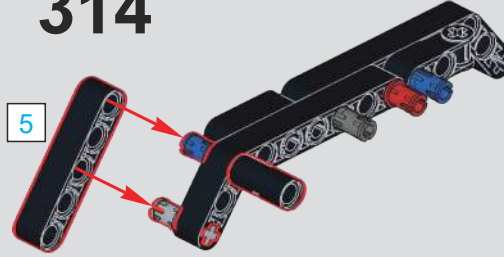

315

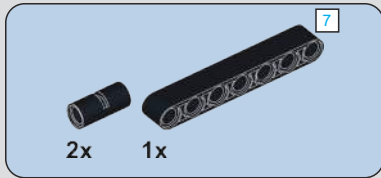
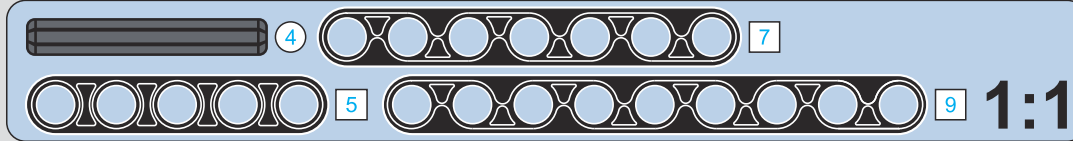
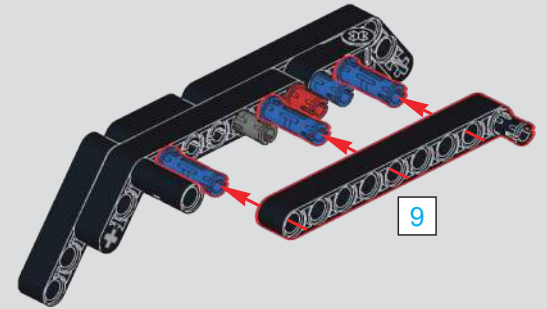

316

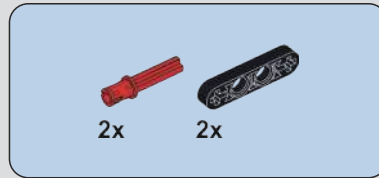
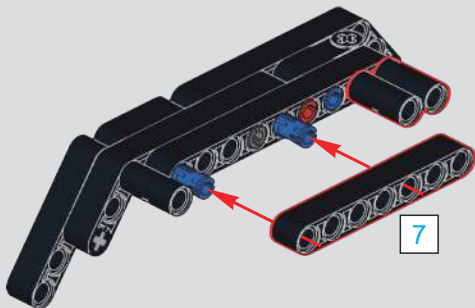

317

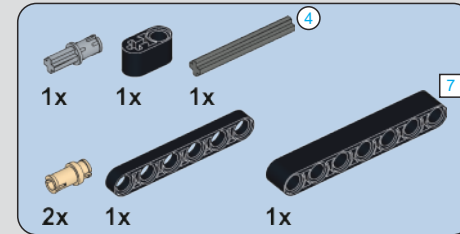
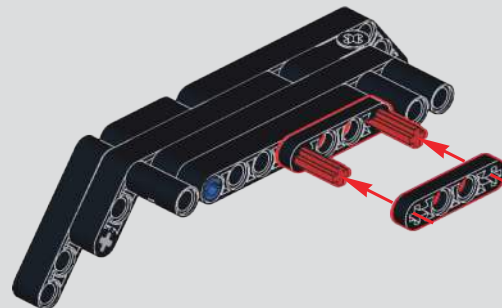

318

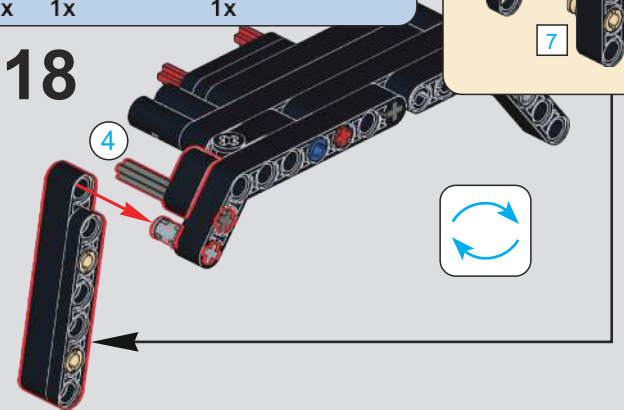

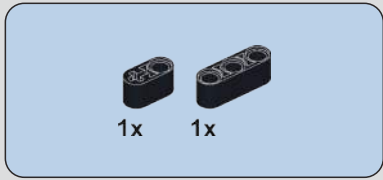

319

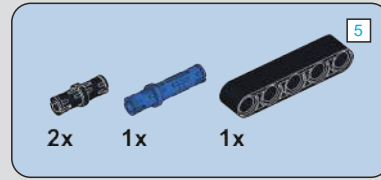
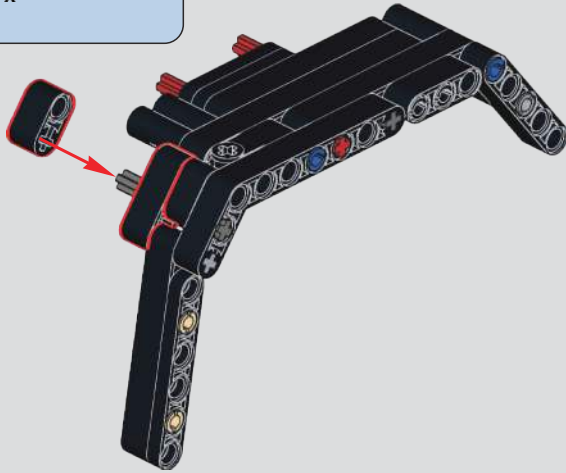

320

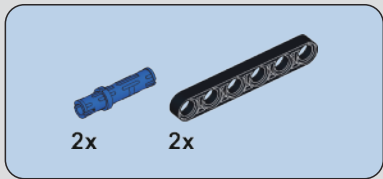
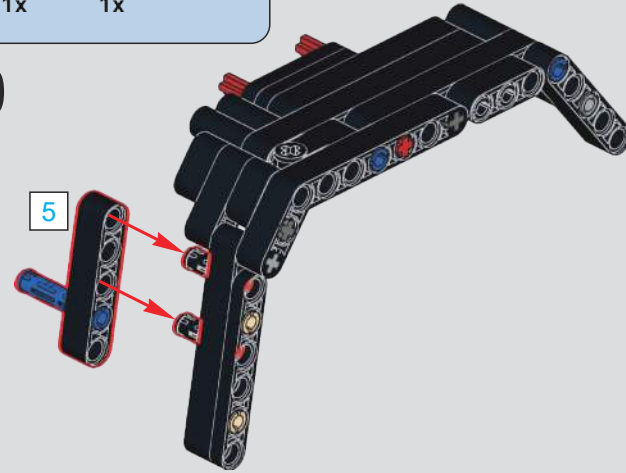

321

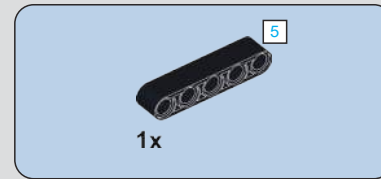
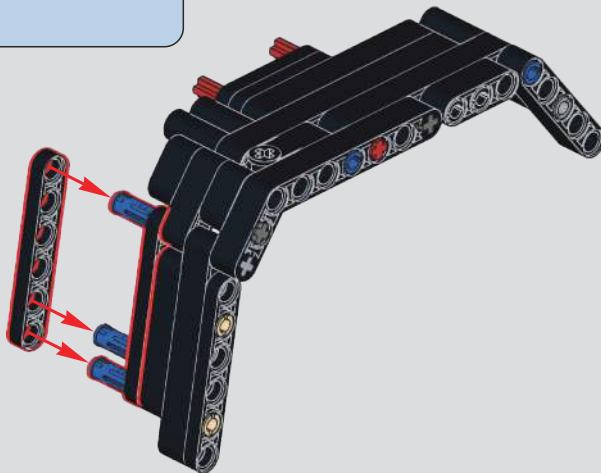

322

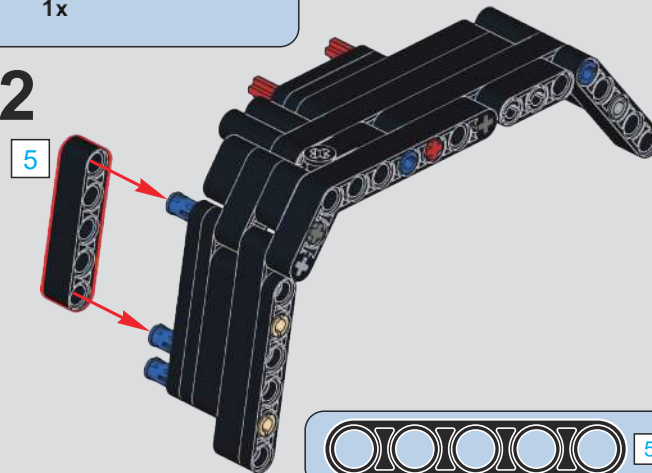

323

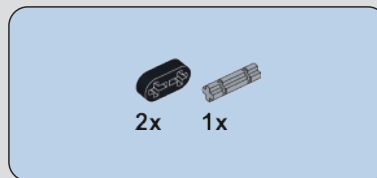
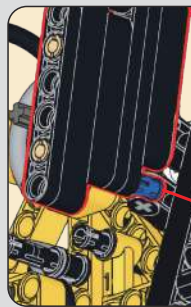
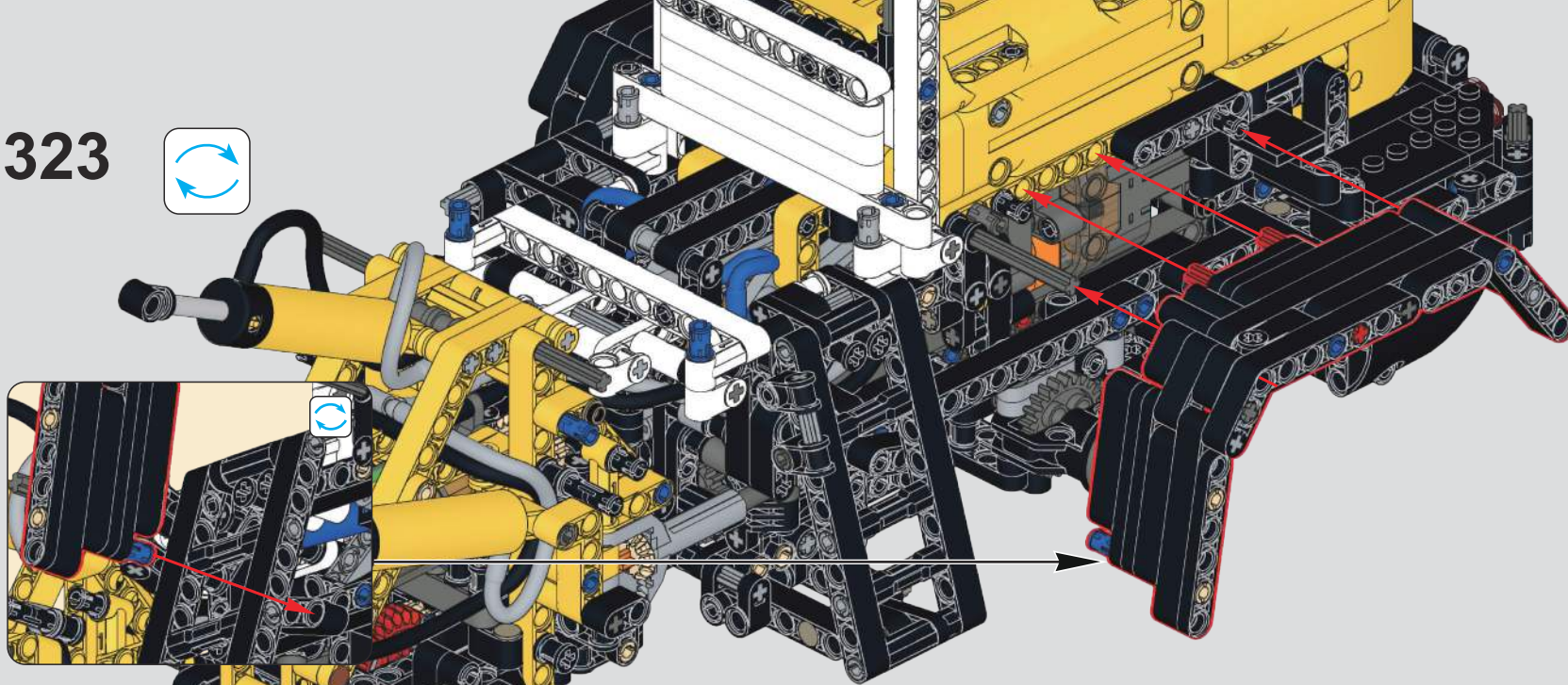

324

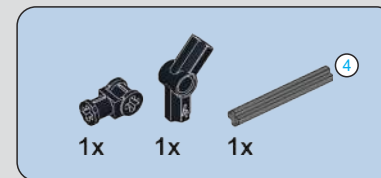

325

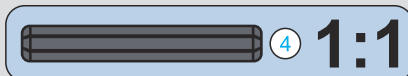
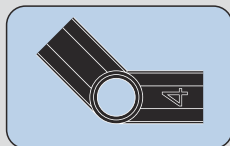
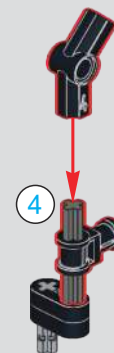

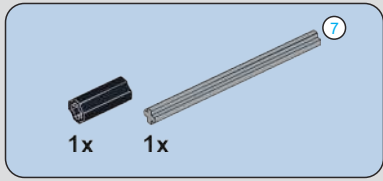

326

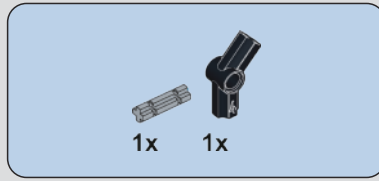
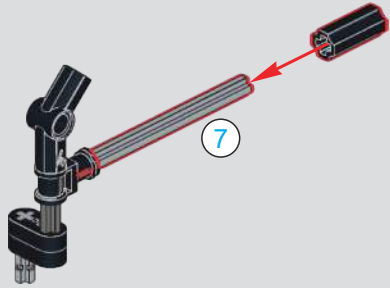

327

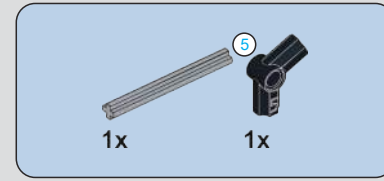
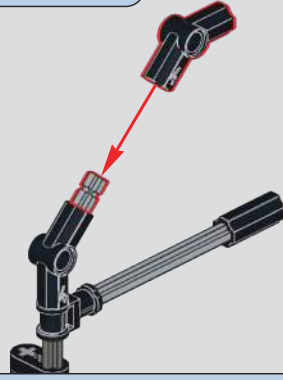

328

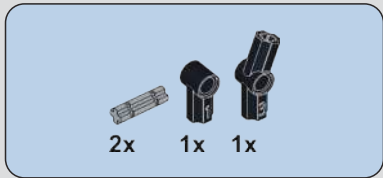

329

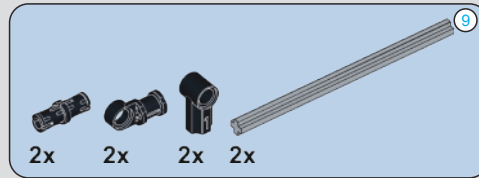
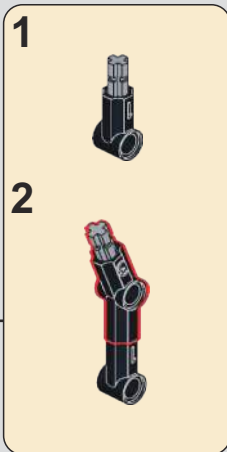
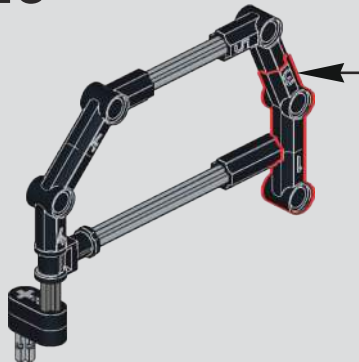

330

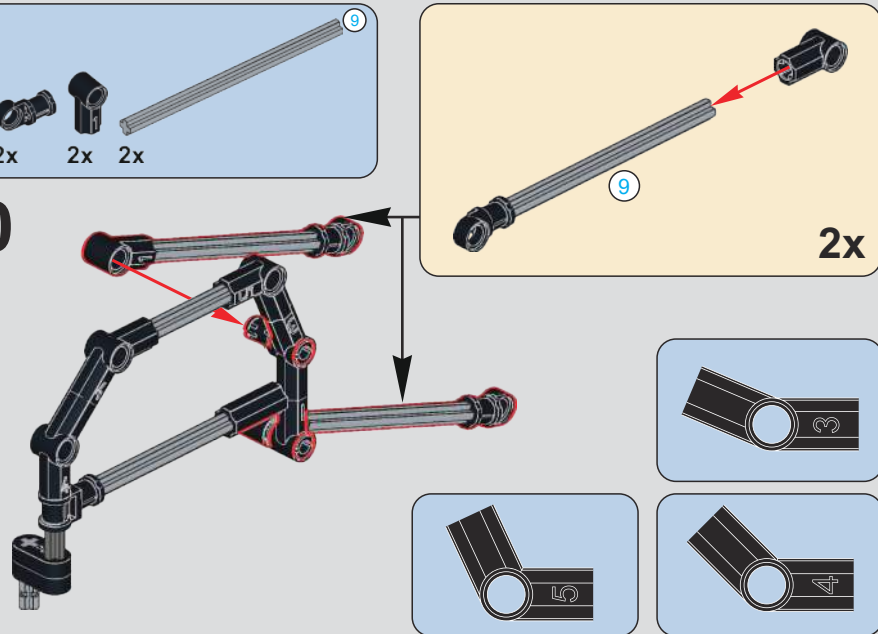

(光滑栓)(Technic Pin without Friction)

2x 1x 1x 1x

331

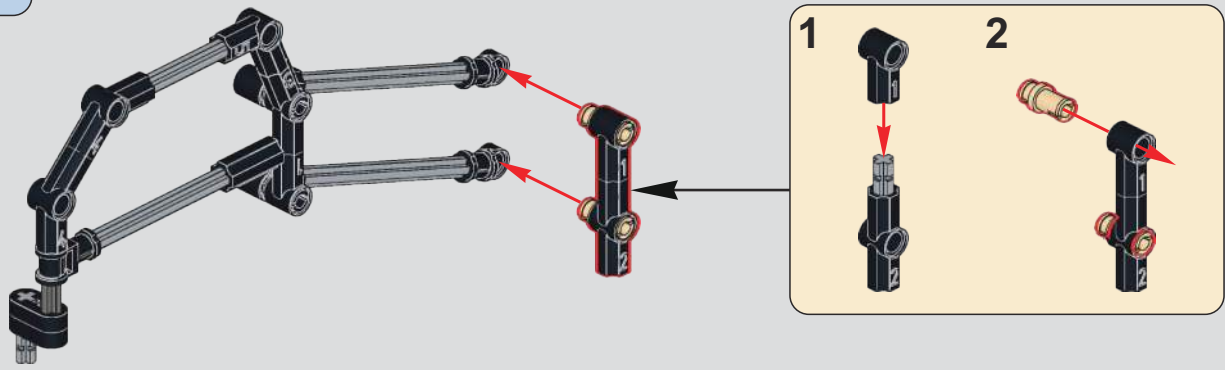

332

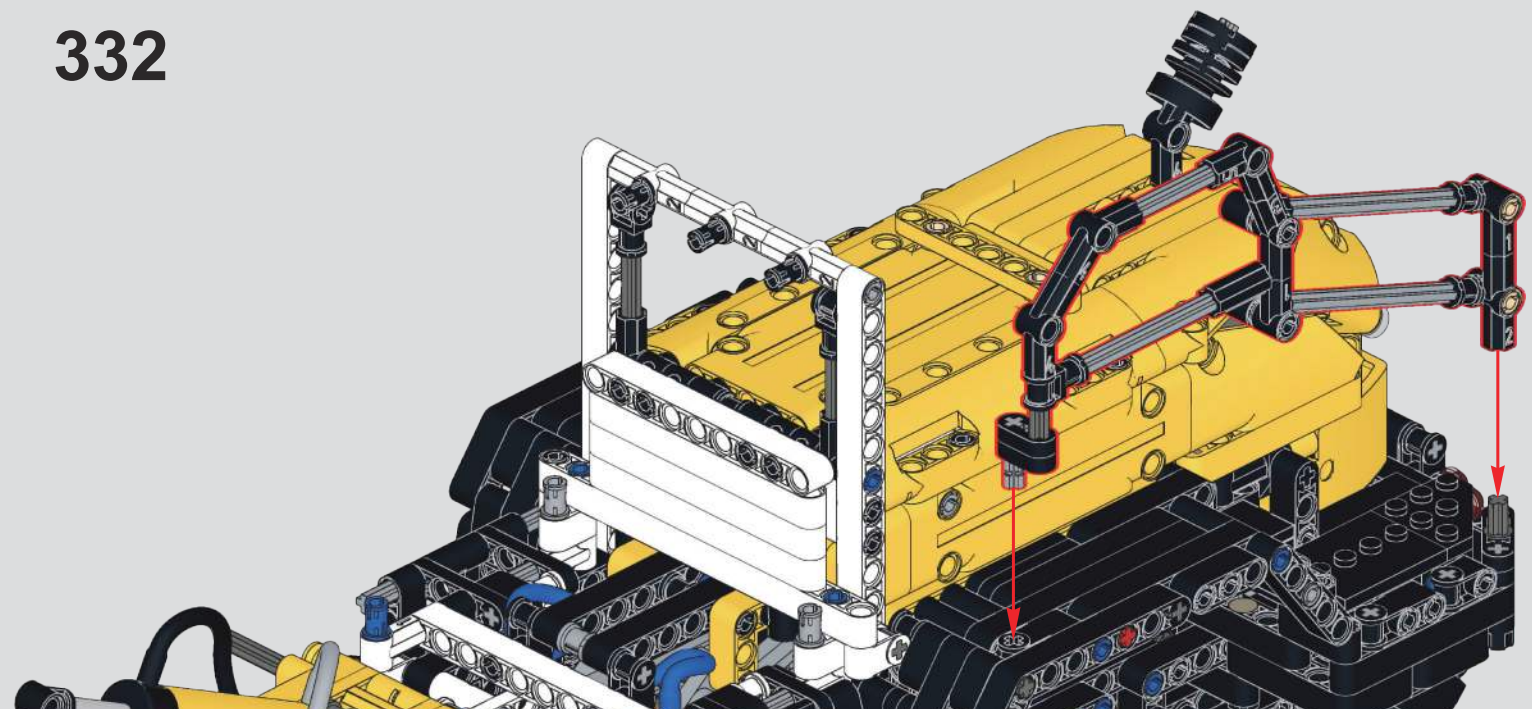

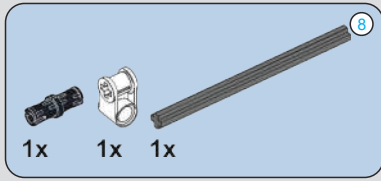

333

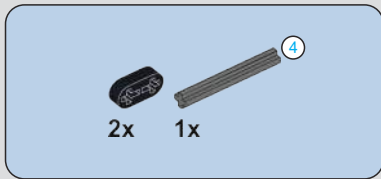
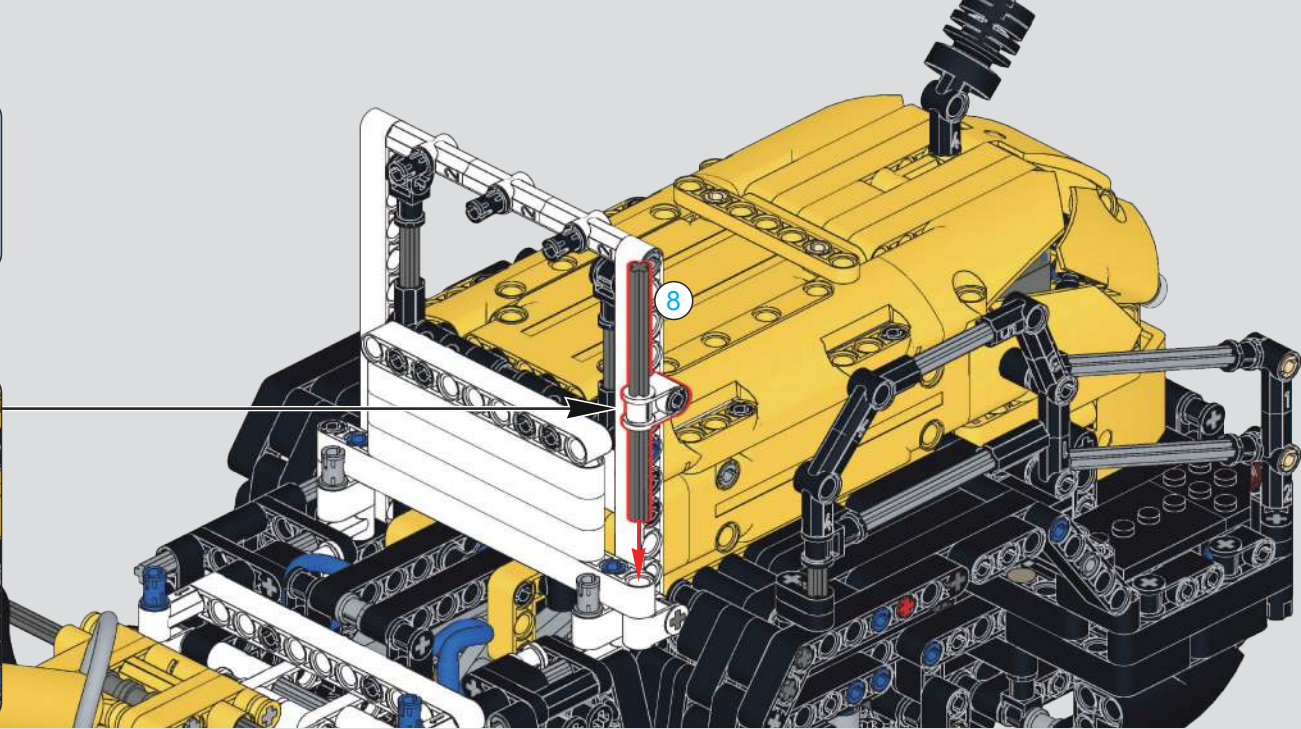
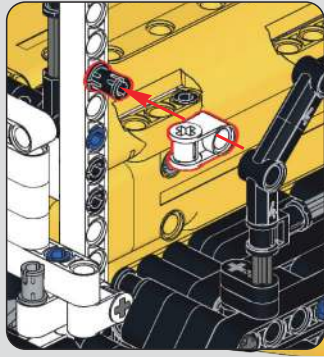

334

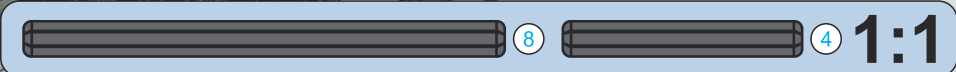
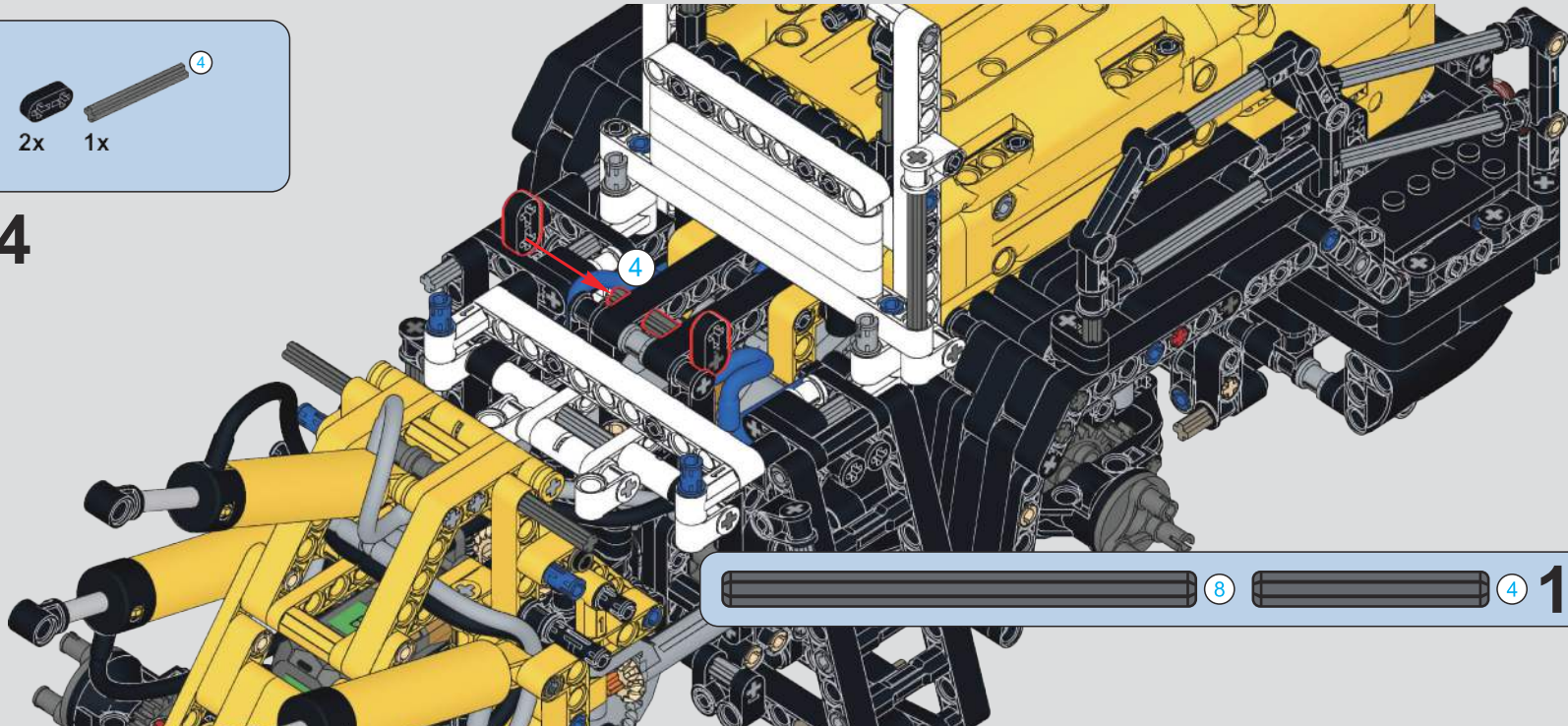

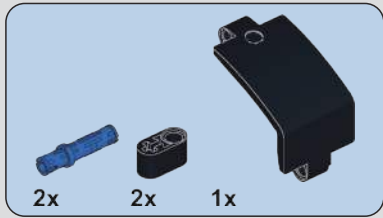

335

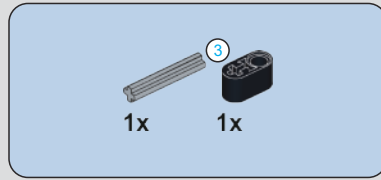

336

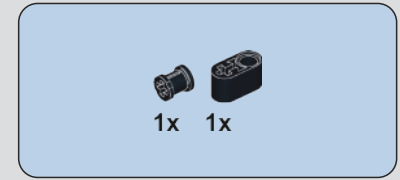

337

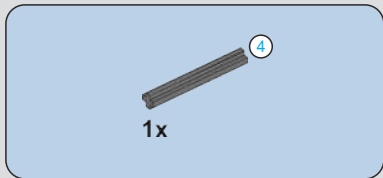
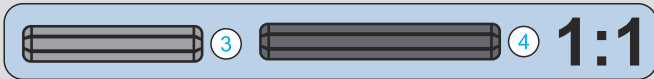

338

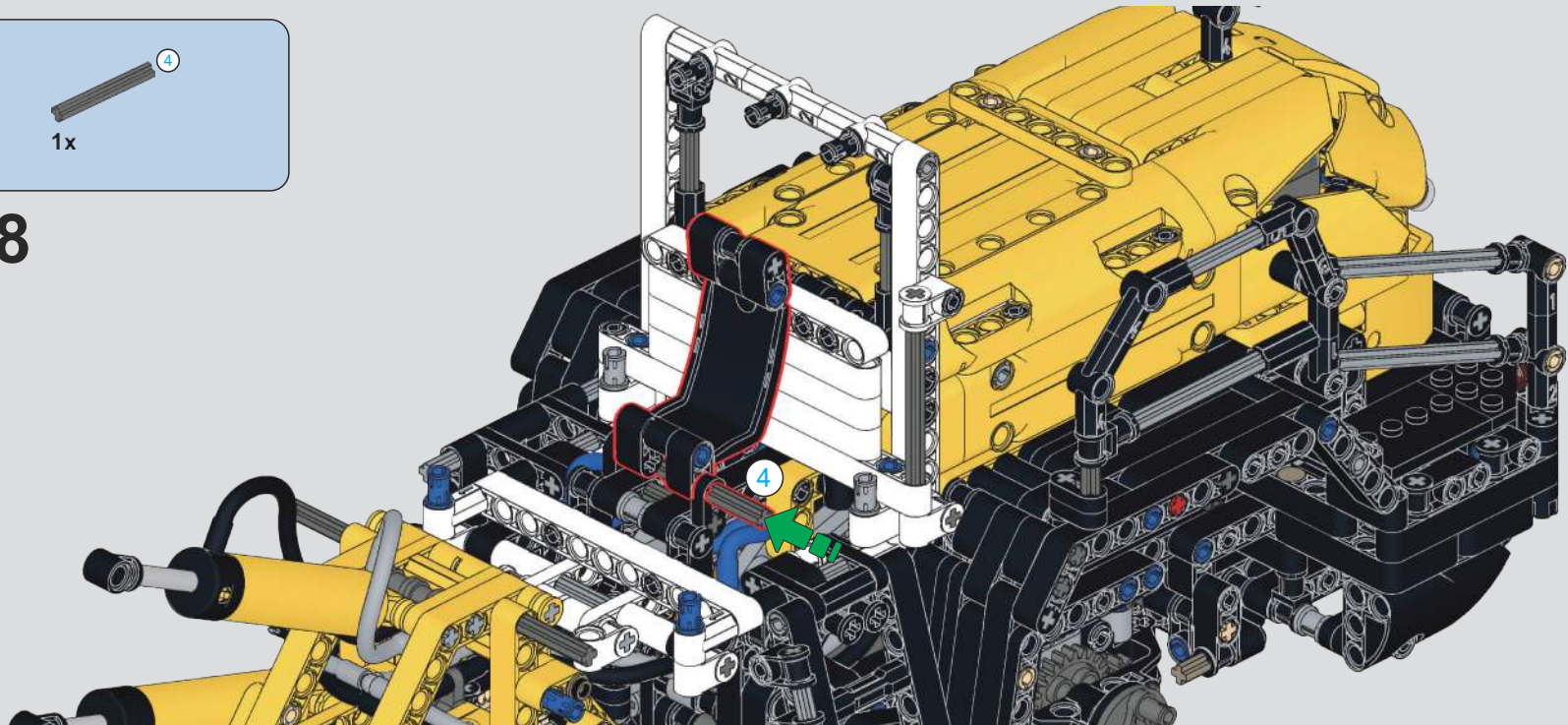

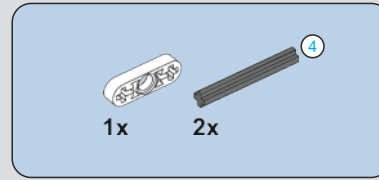
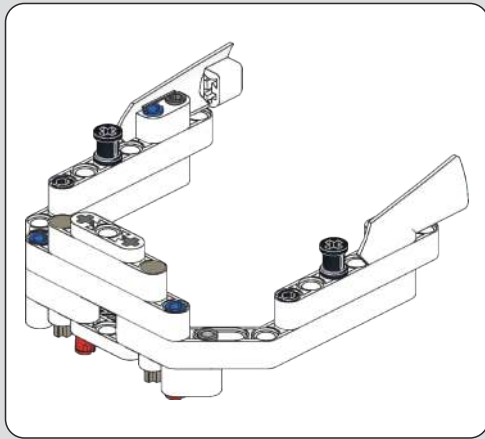

339

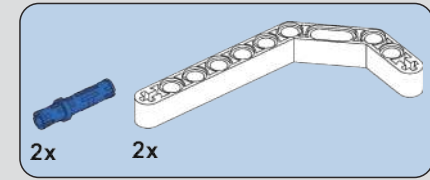
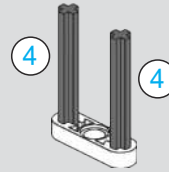

340

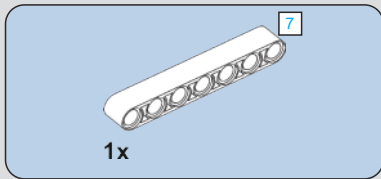
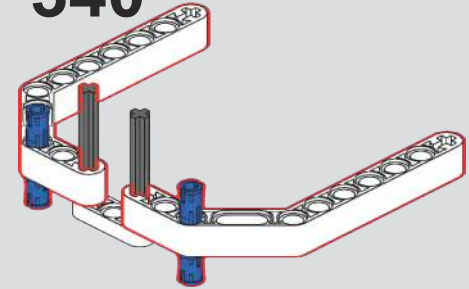

341

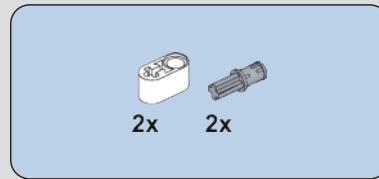
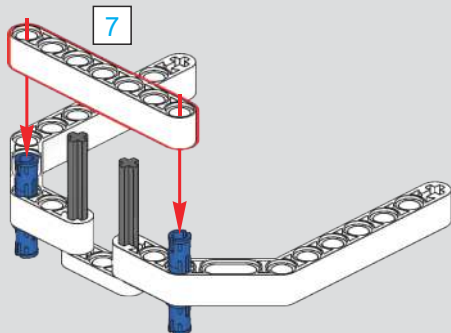

342

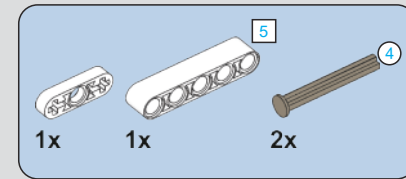
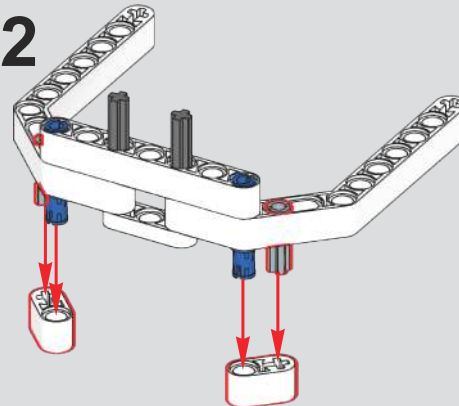

343

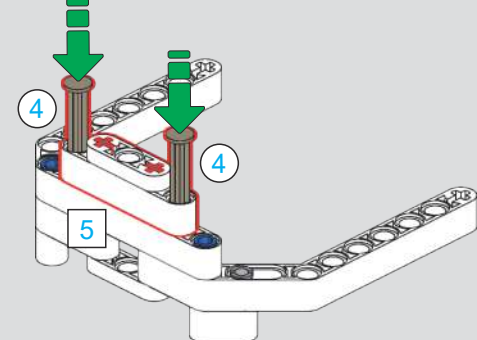

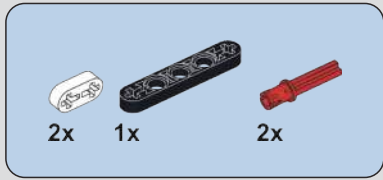

344

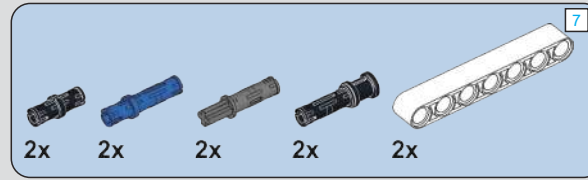
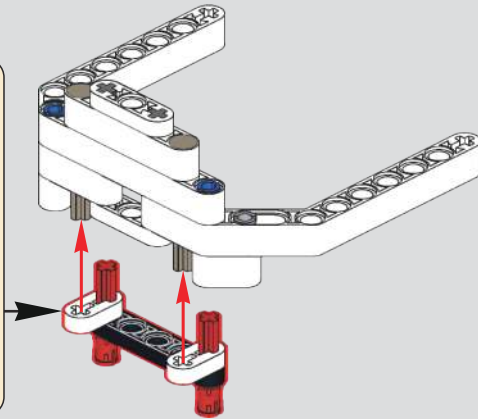
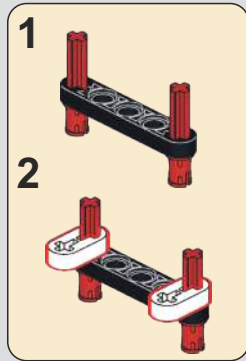

345

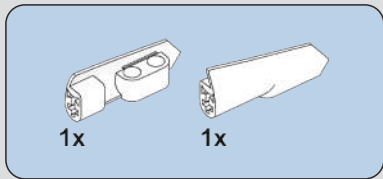
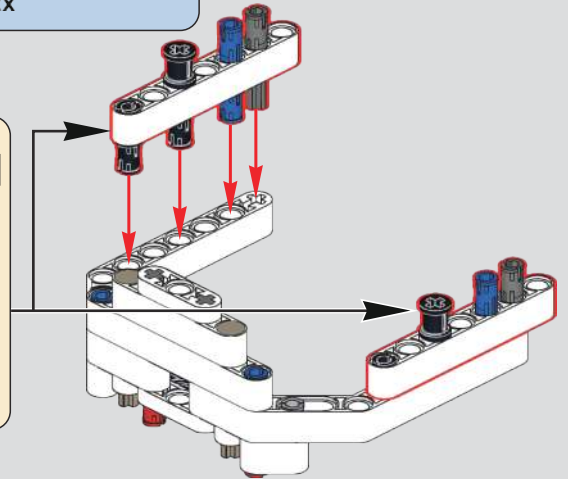
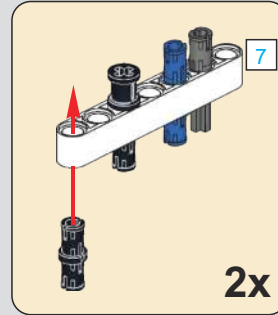

346

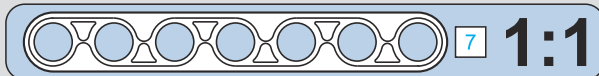
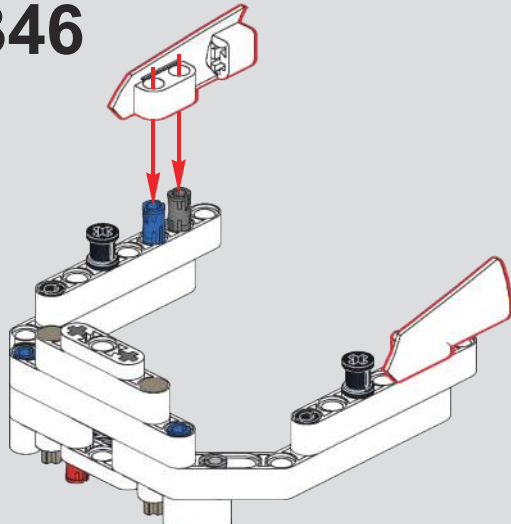

347

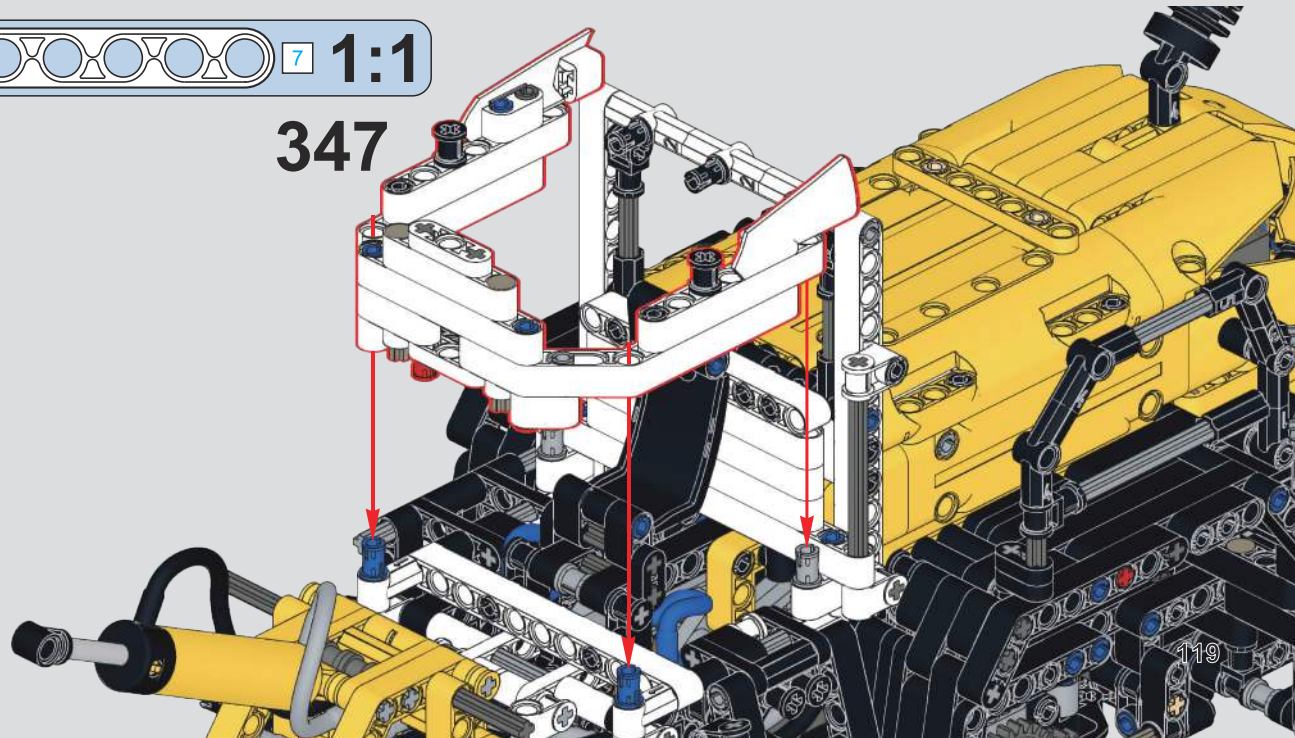

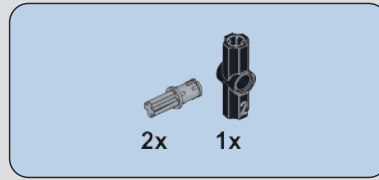

348

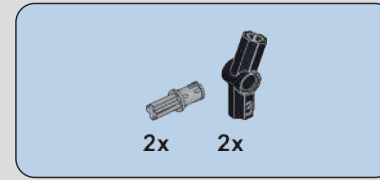

349

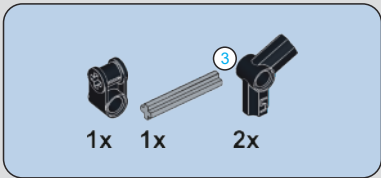
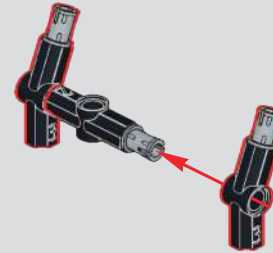
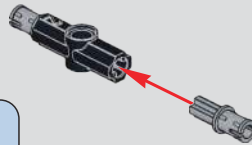
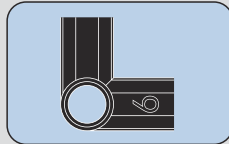
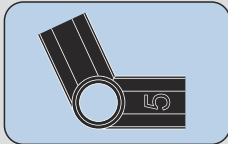
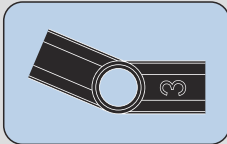
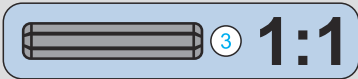

350

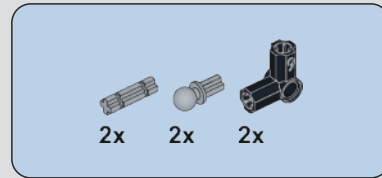
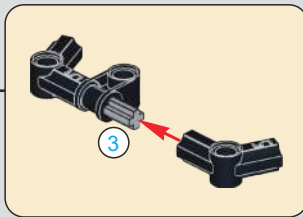
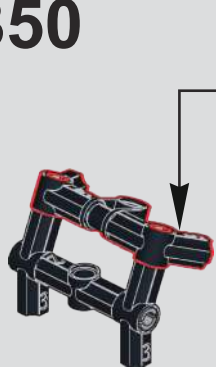

351

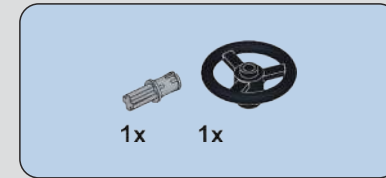
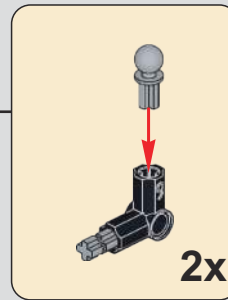
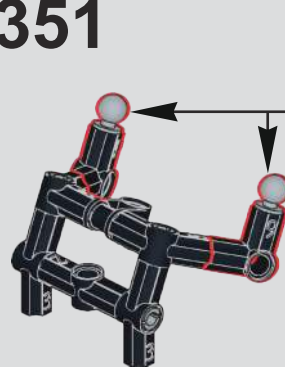

352

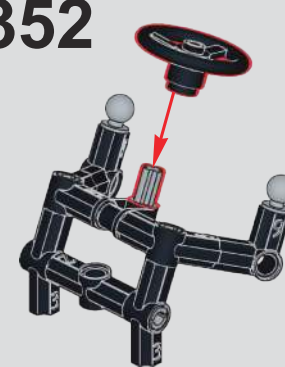

353

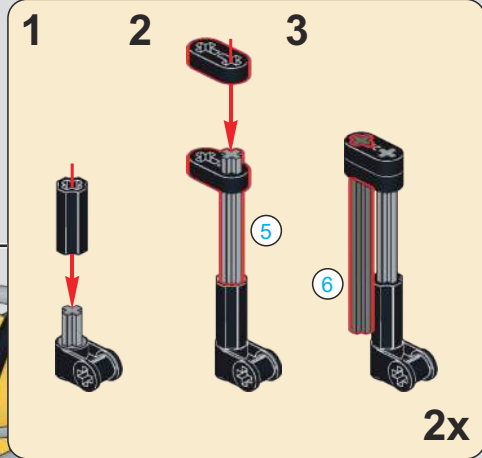
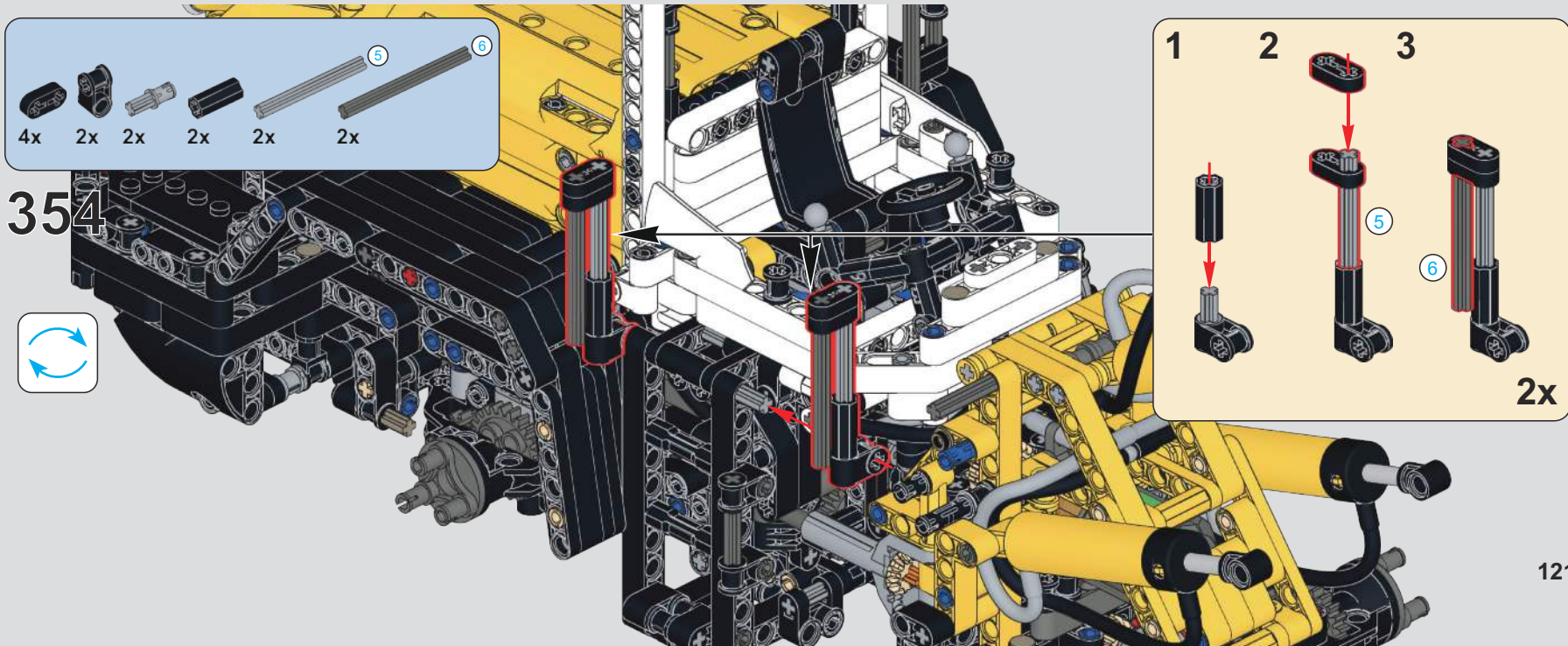
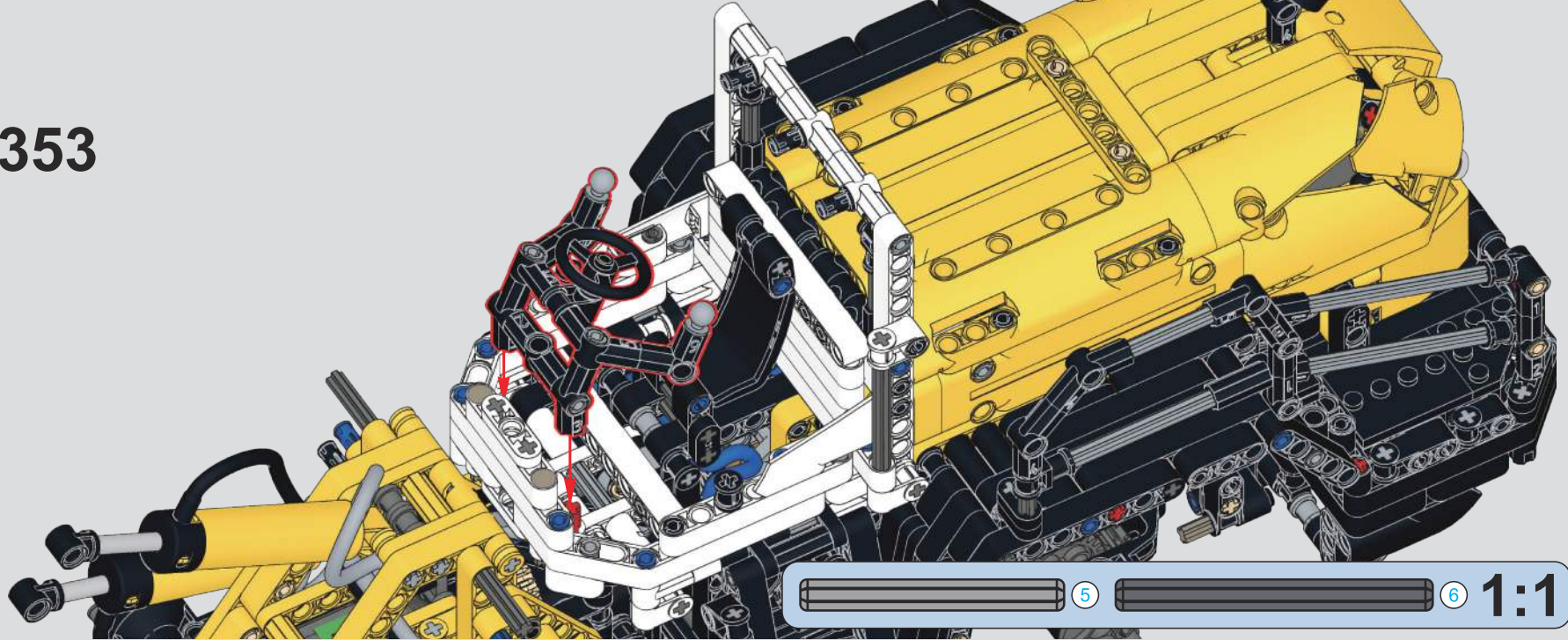

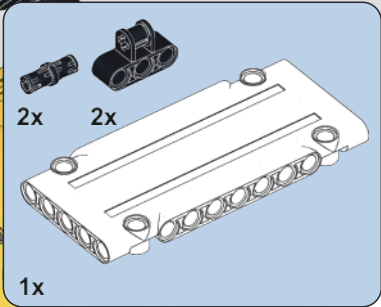
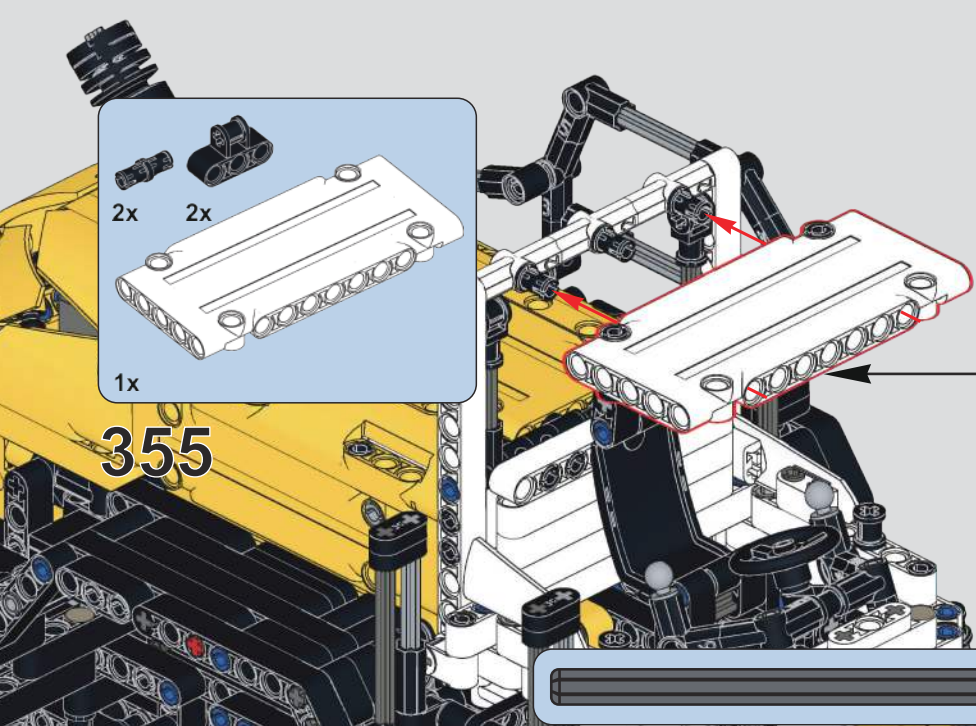

355

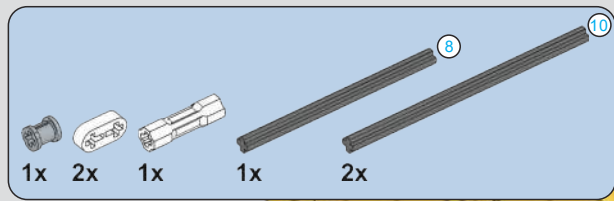
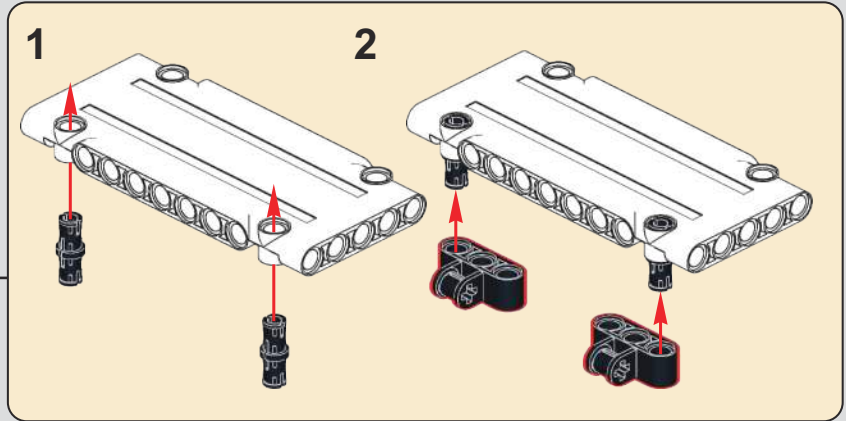

356

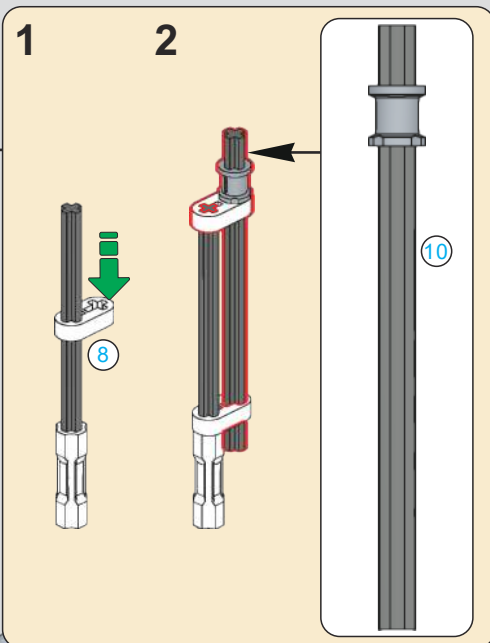
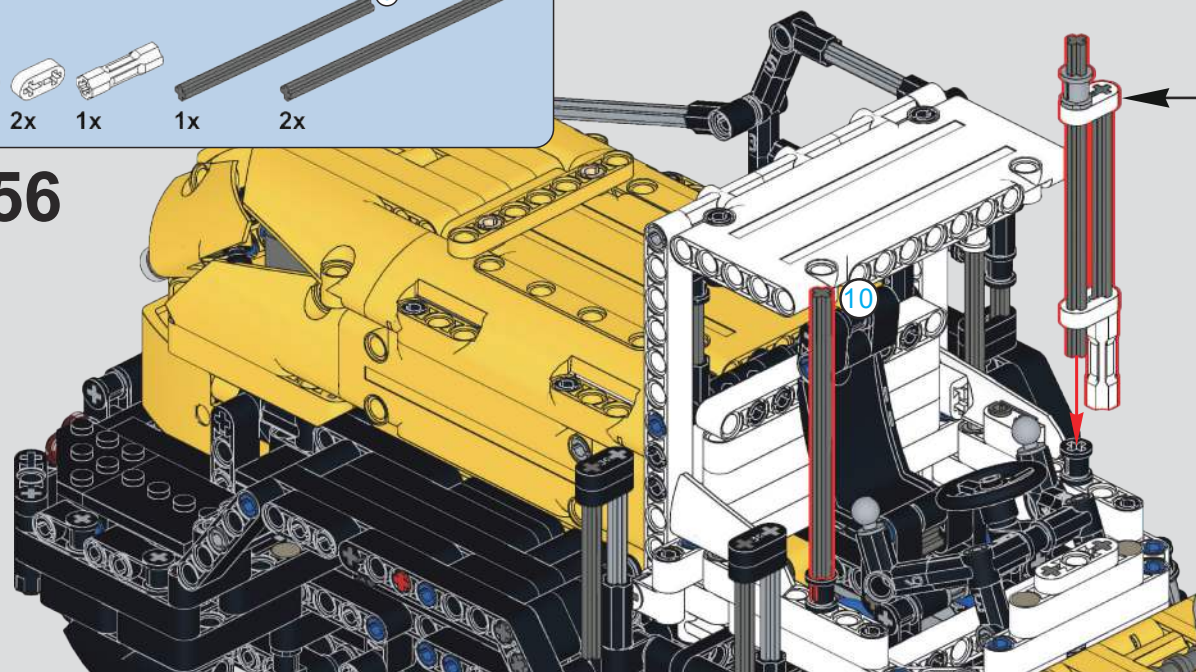

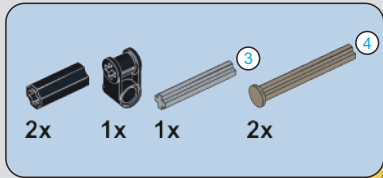

357

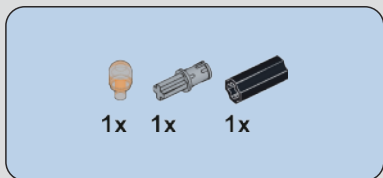
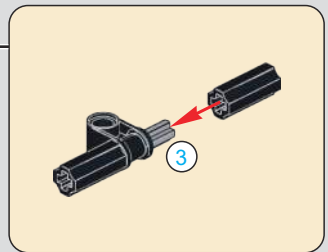
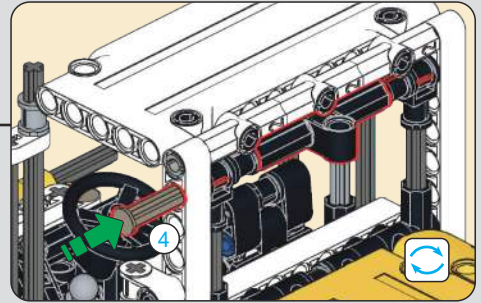
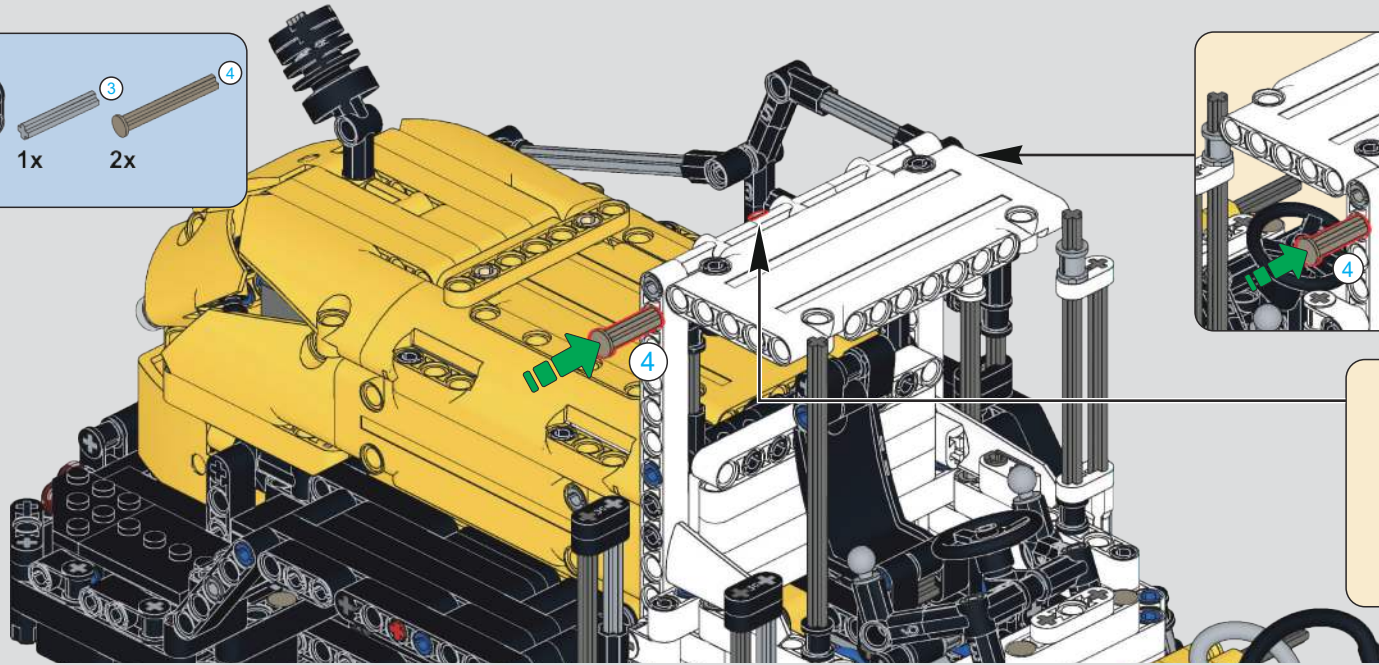

358

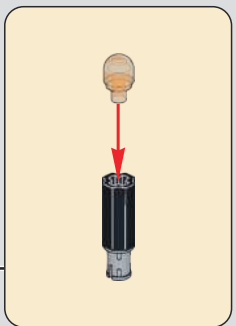
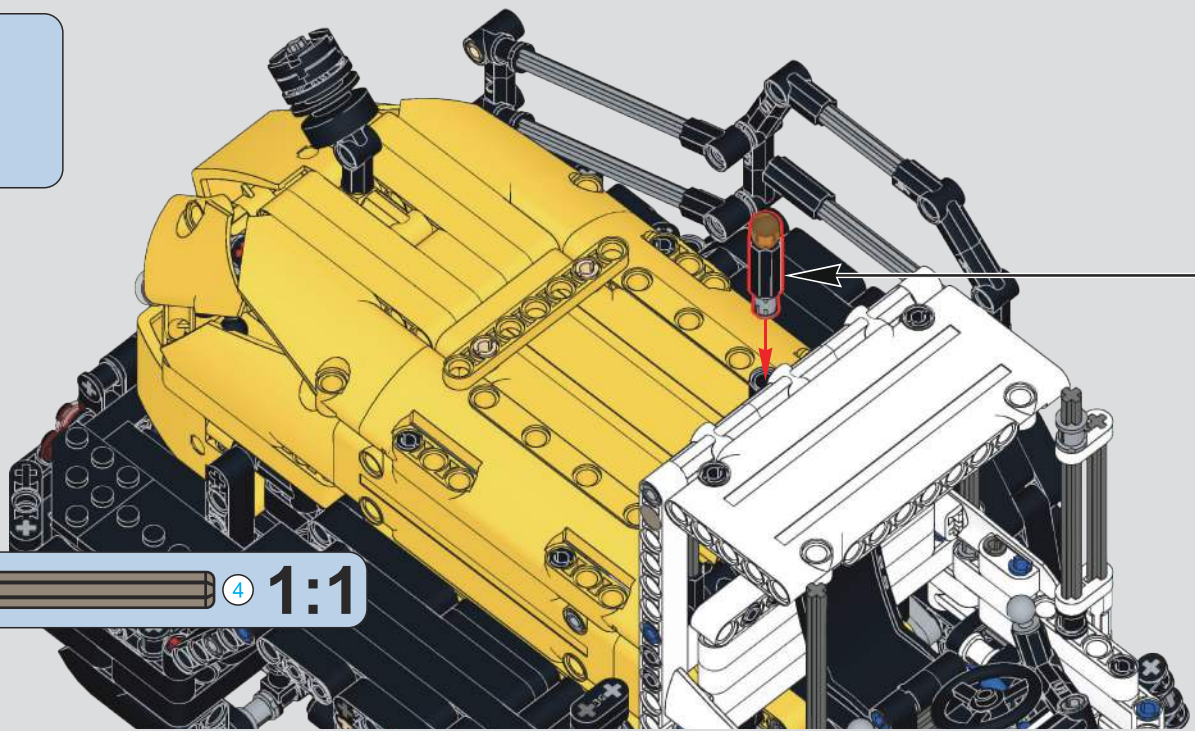

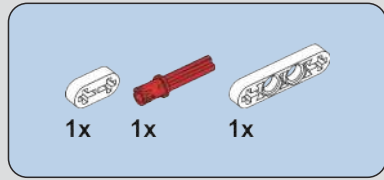
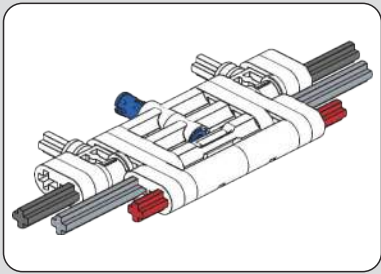

360

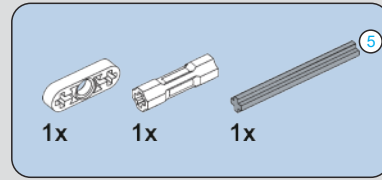

361

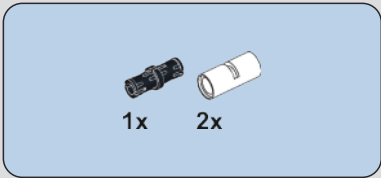
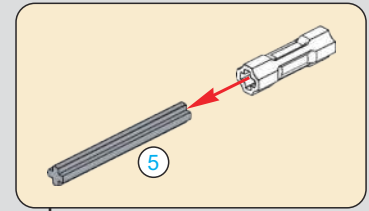

359

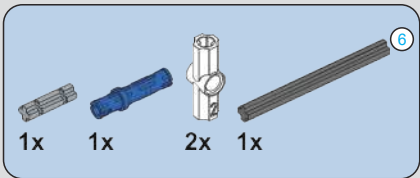
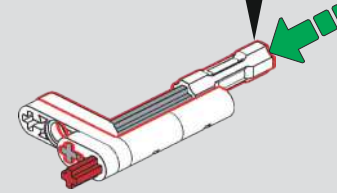
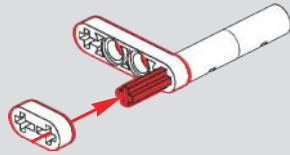
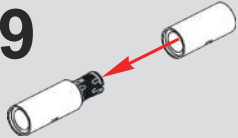

362

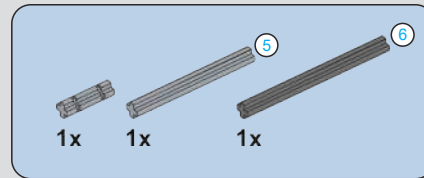
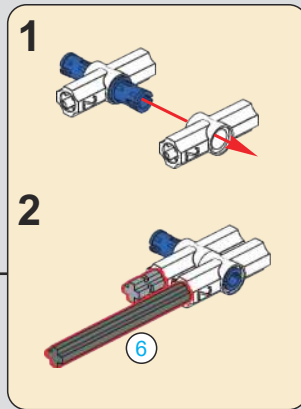

363

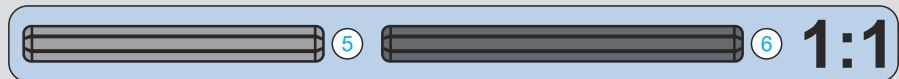
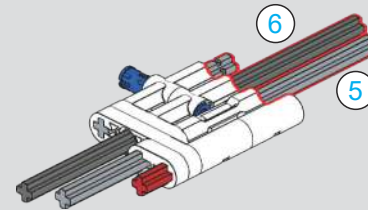
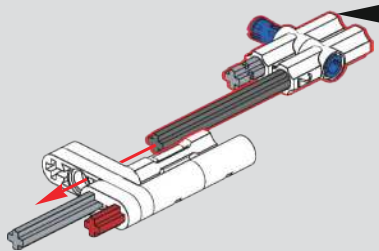

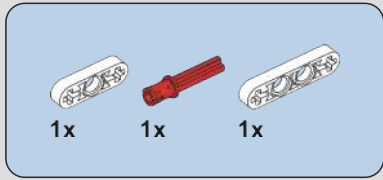

364

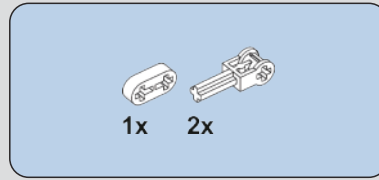
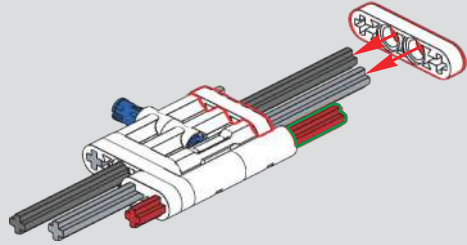

365

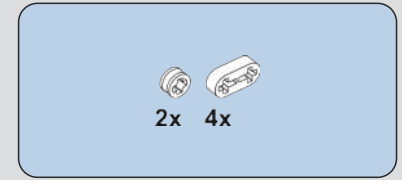
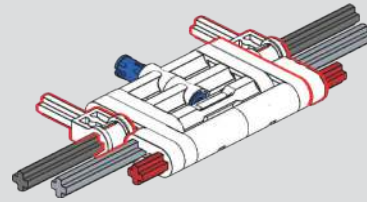

366

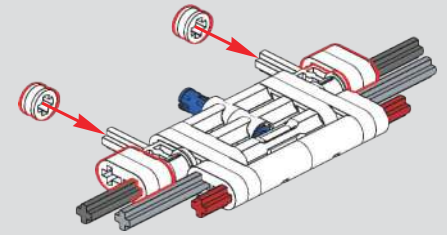

367

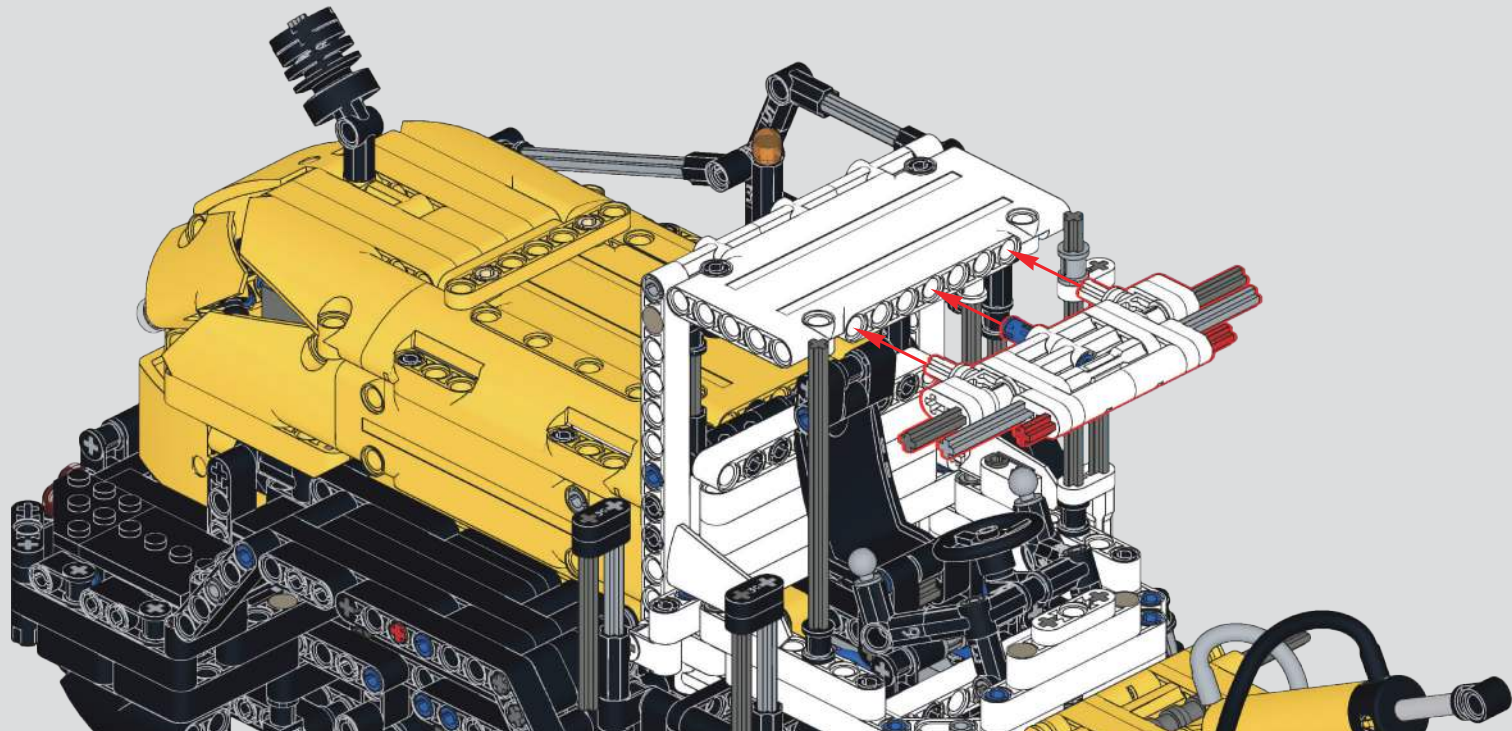



2x

368

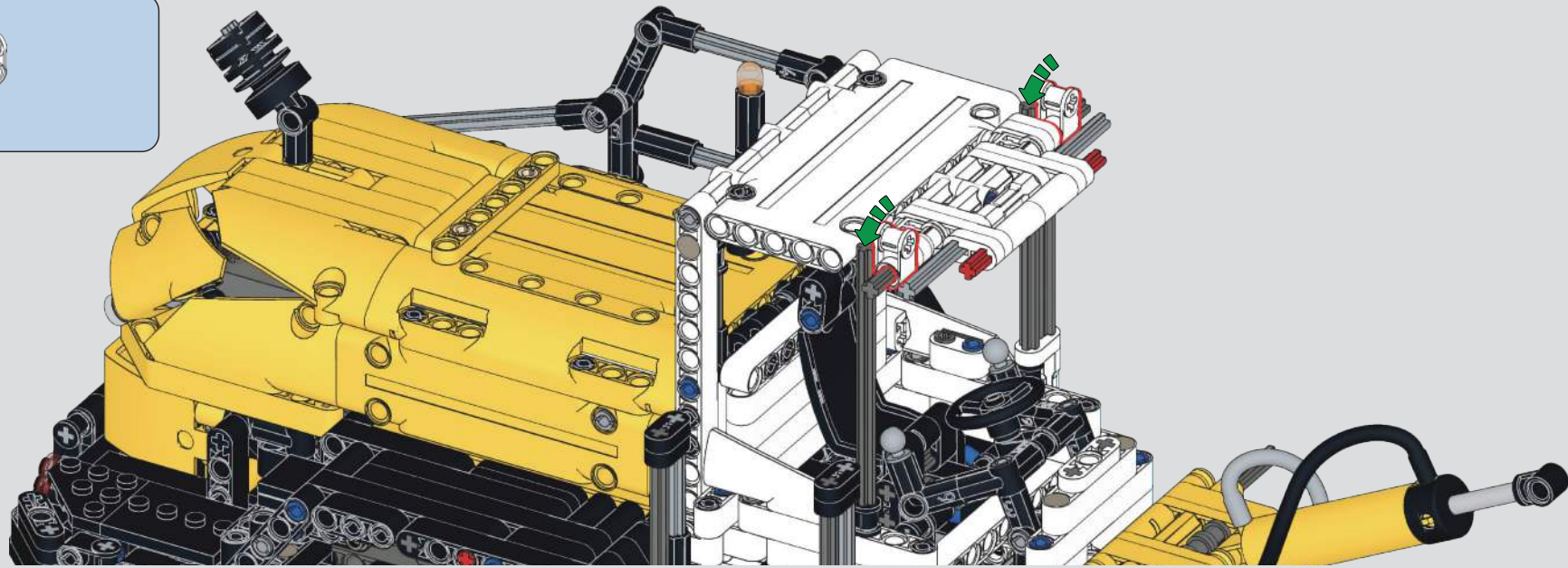

369

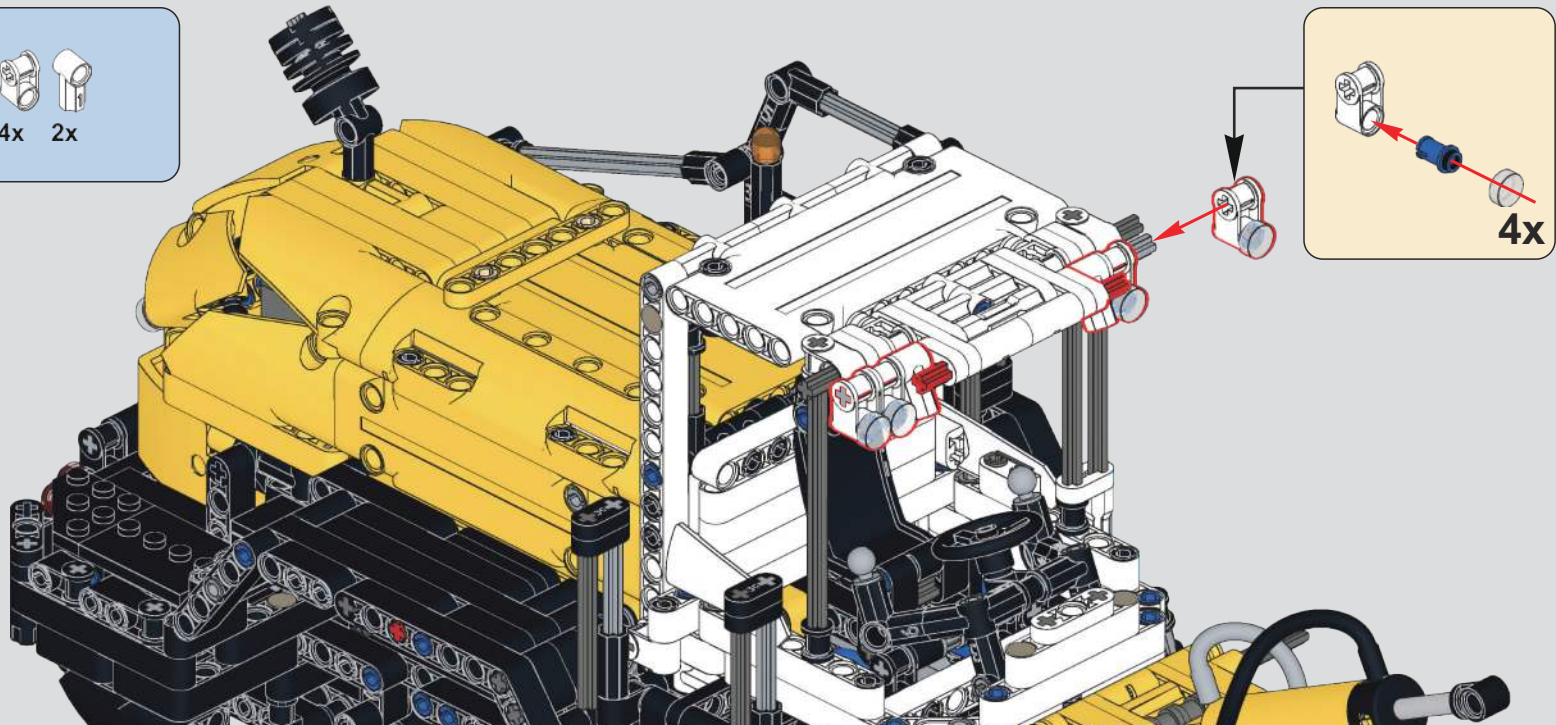

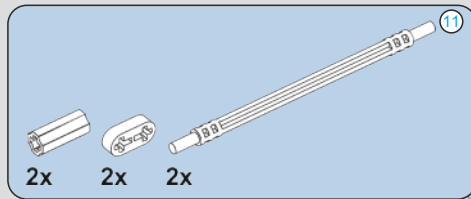

370

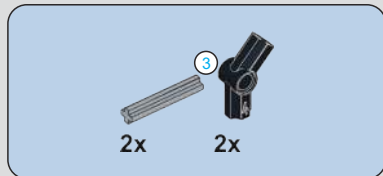
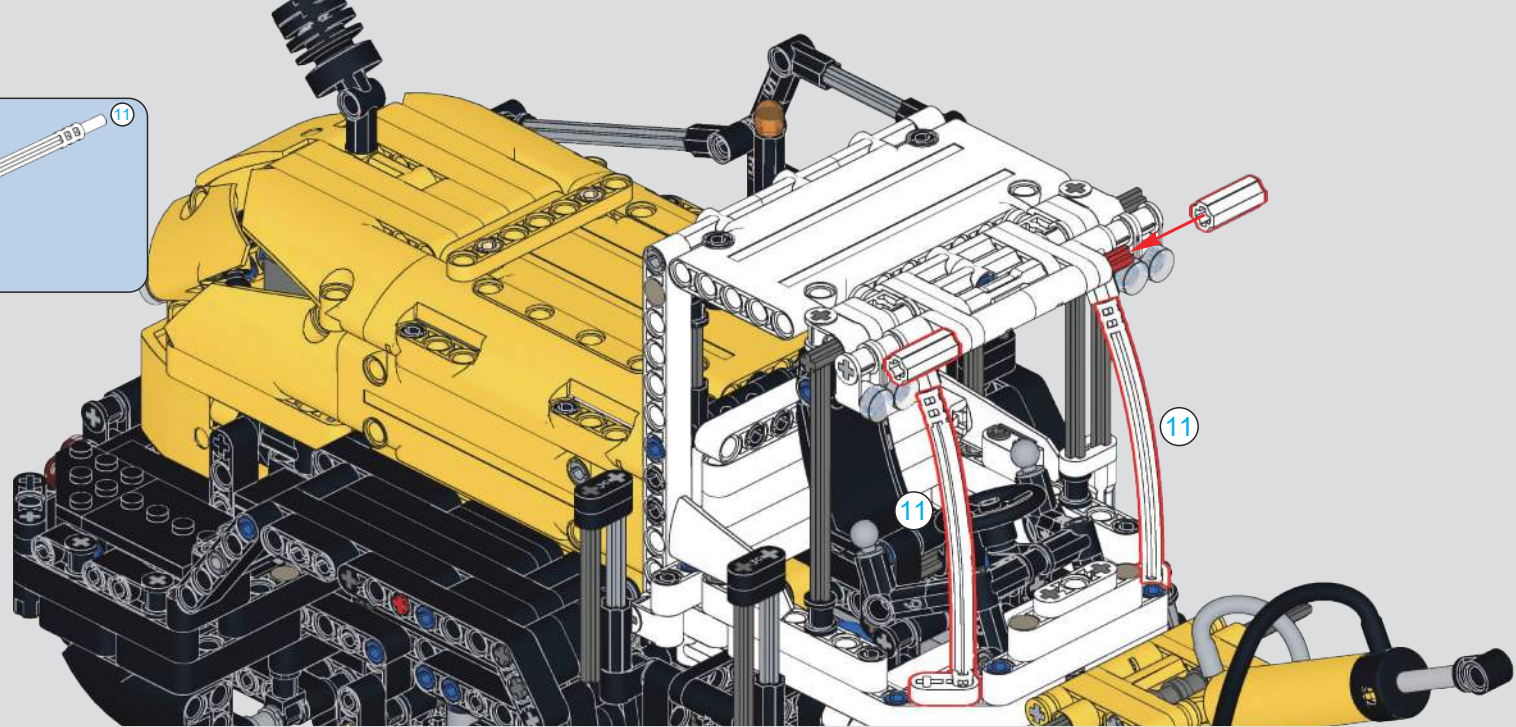

371

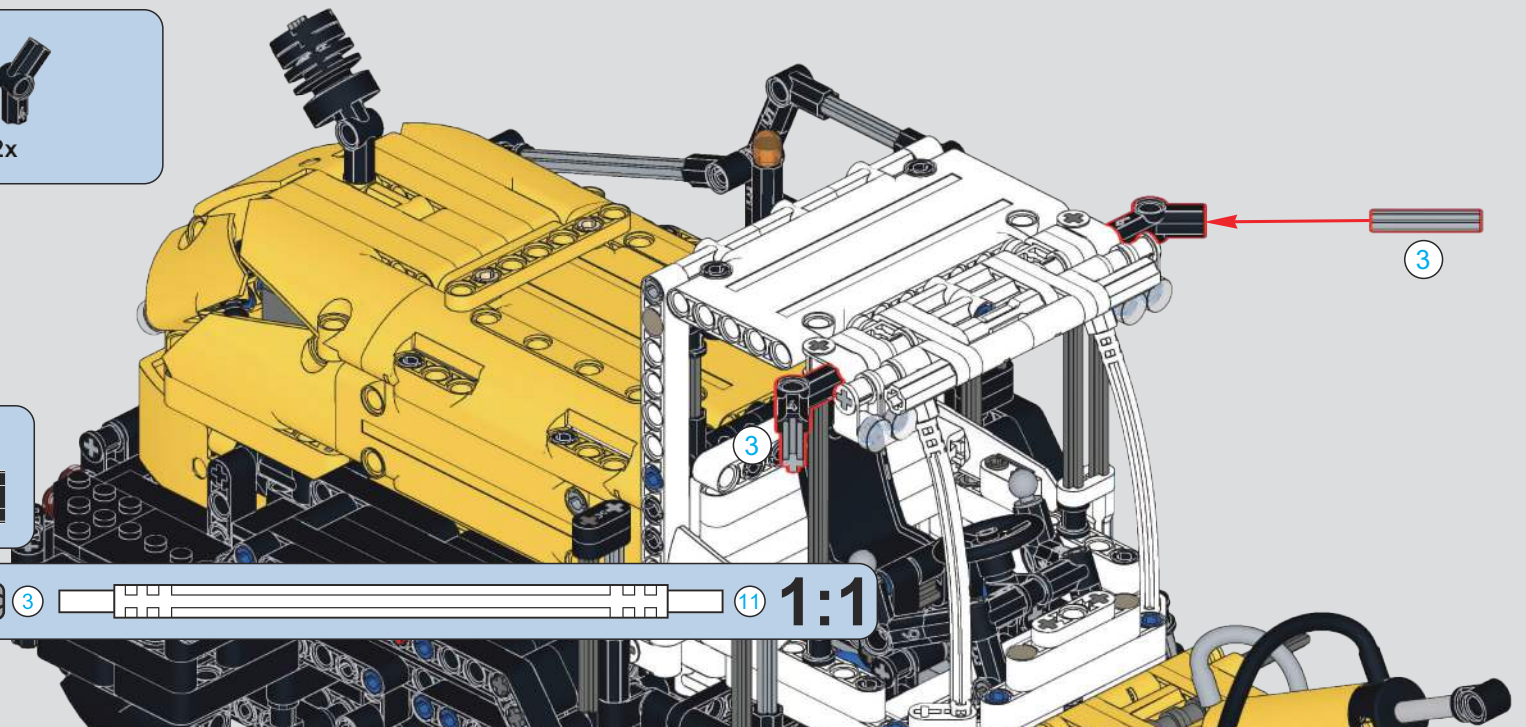
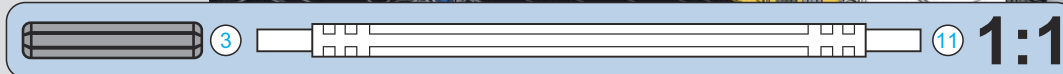
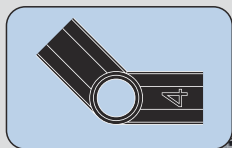

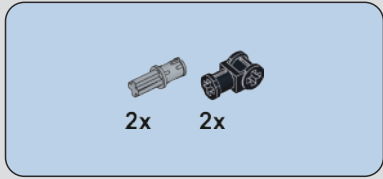

372

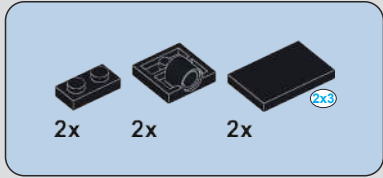
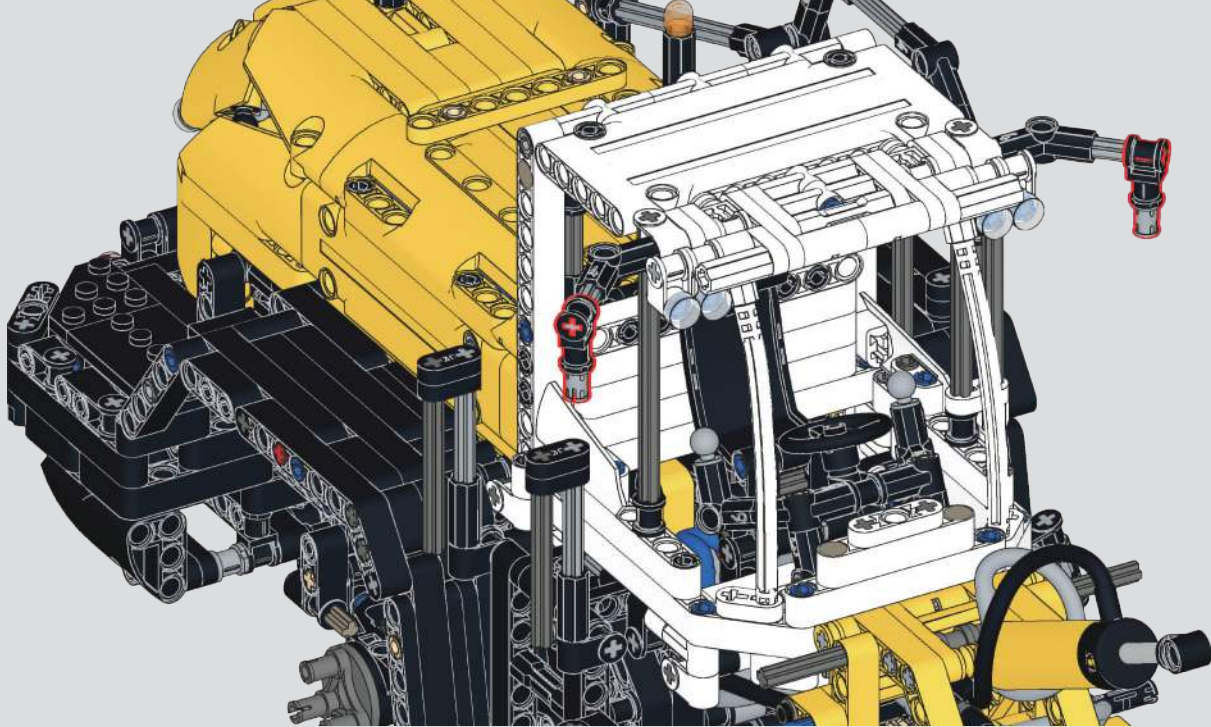

373

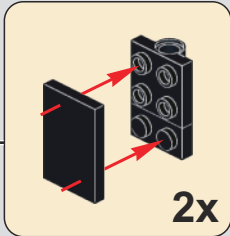
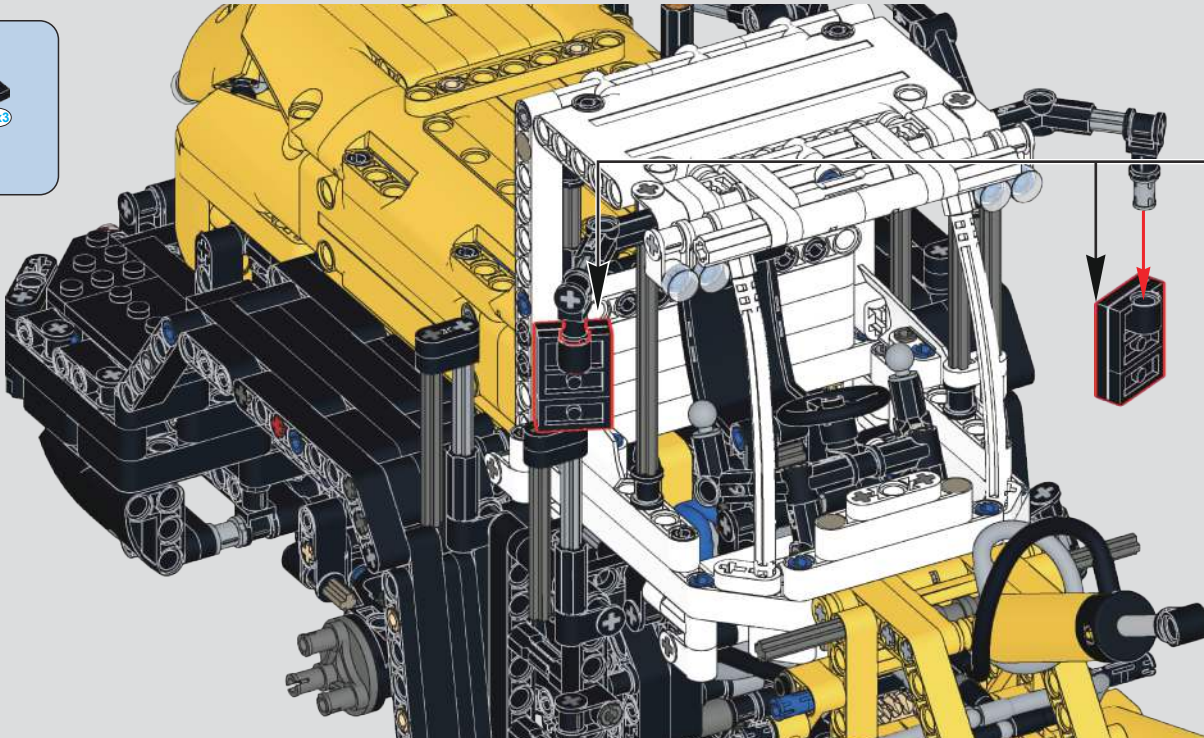

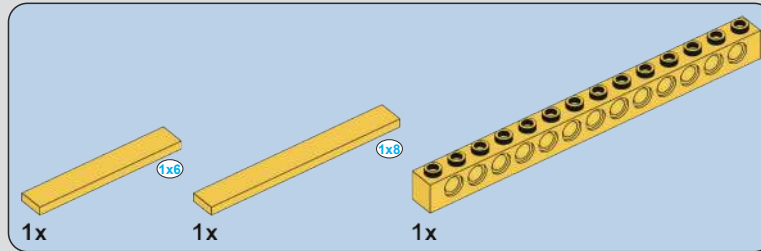
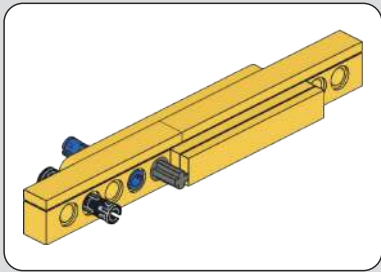

374

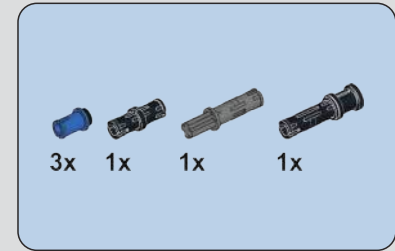
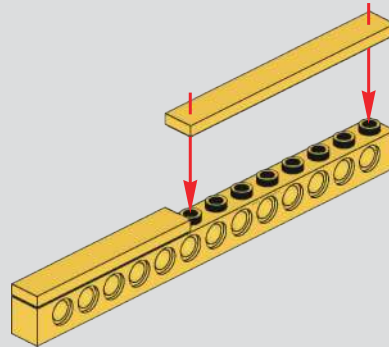

375

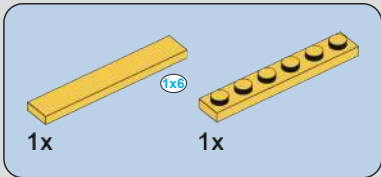
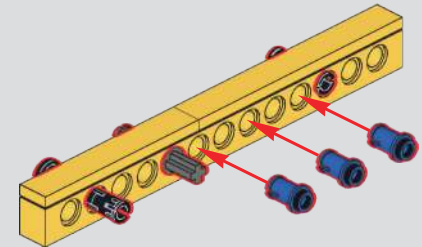

376

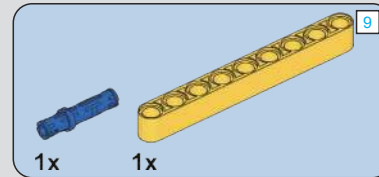
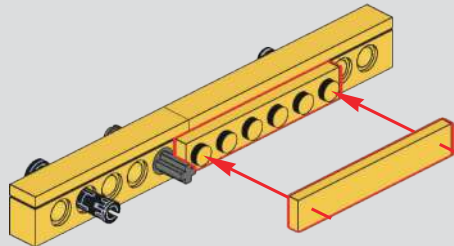

377

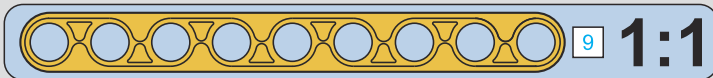
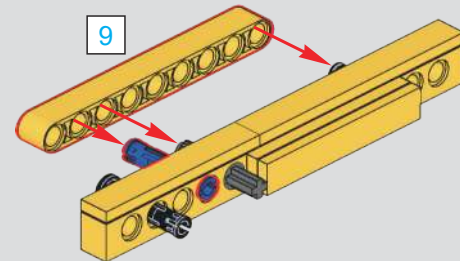

378

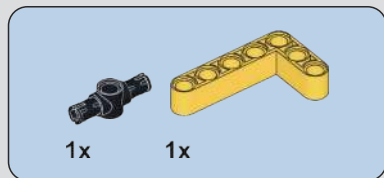
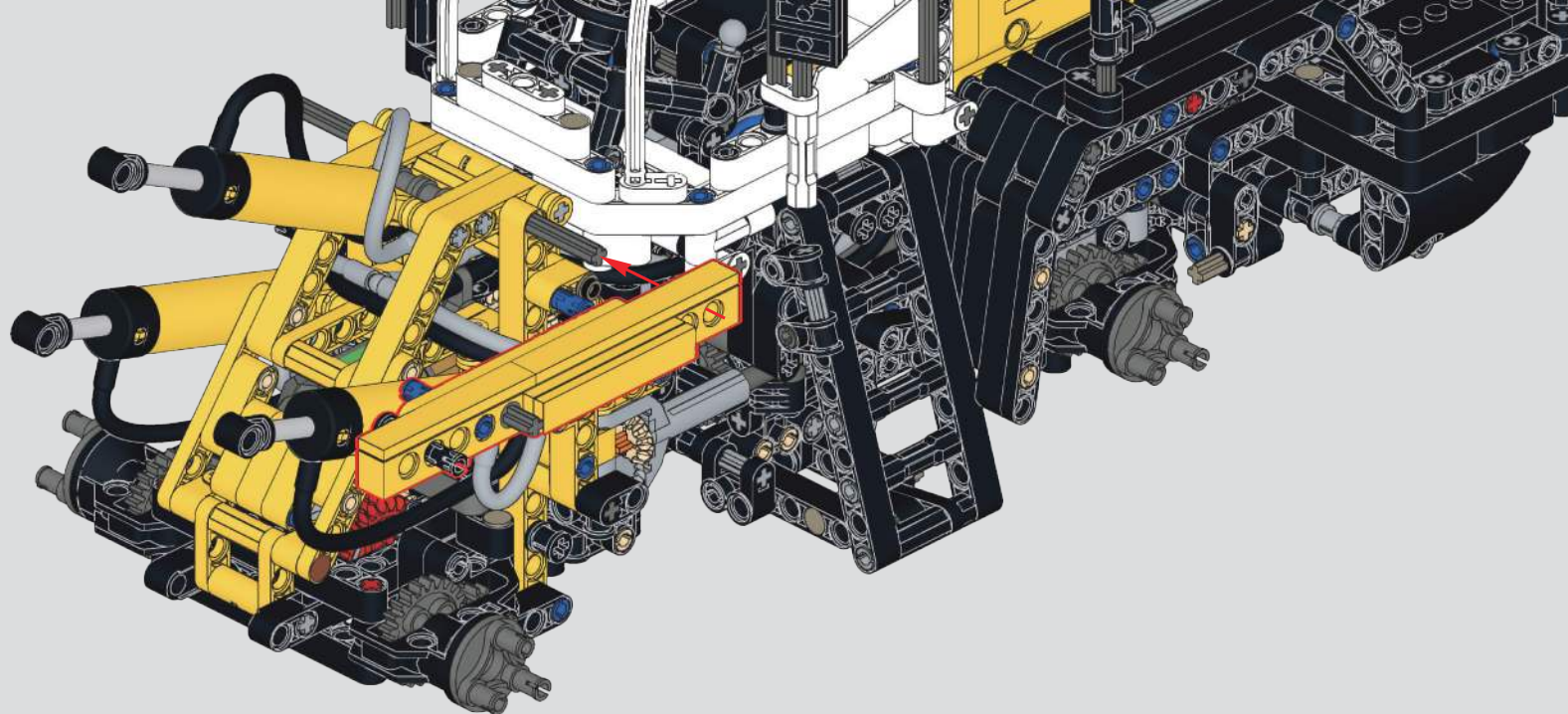

379

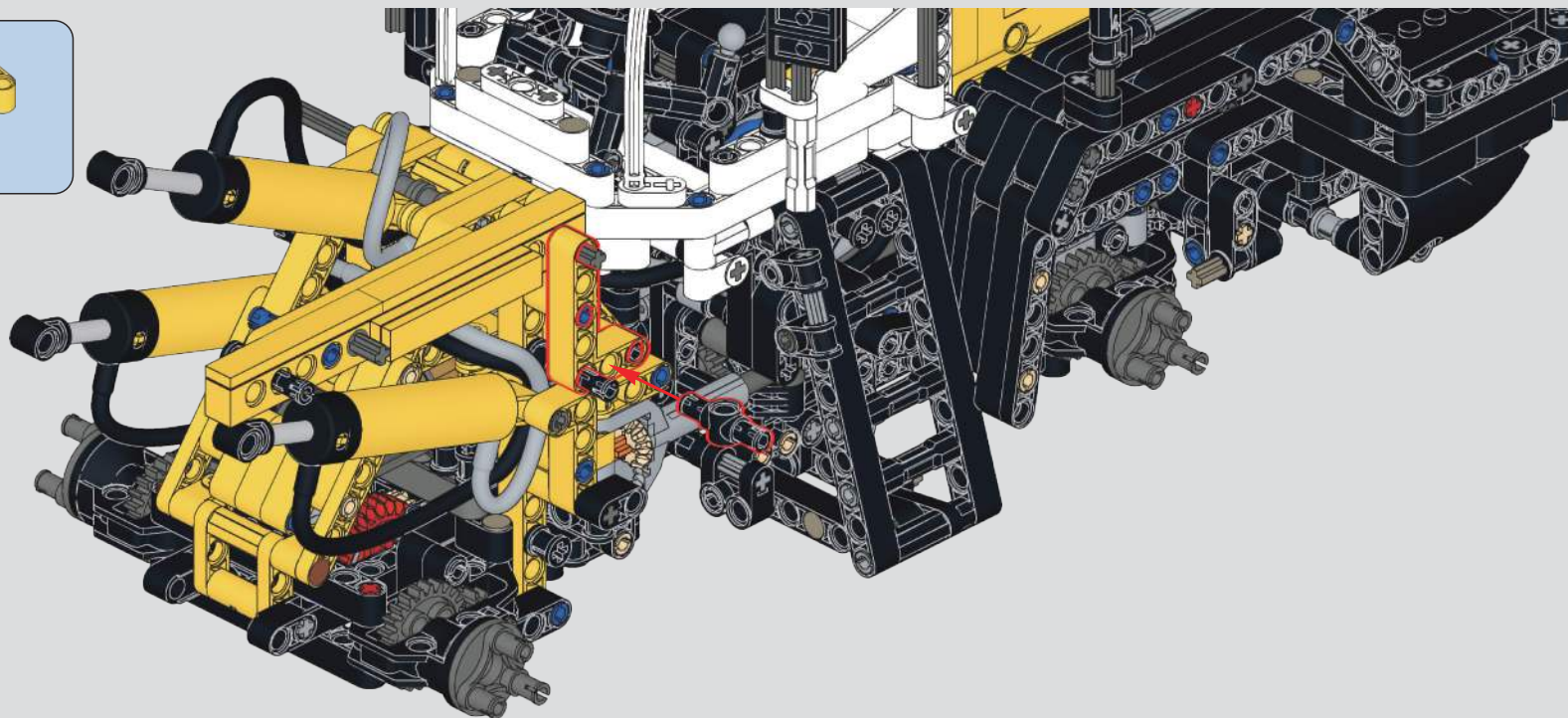

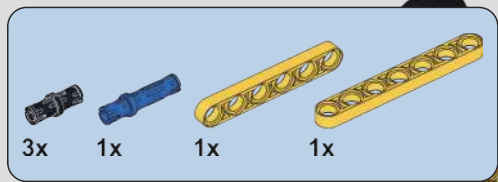

380

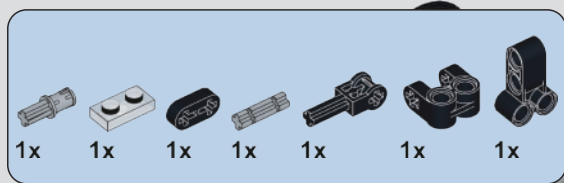
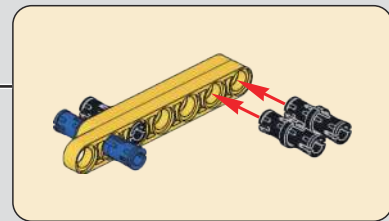
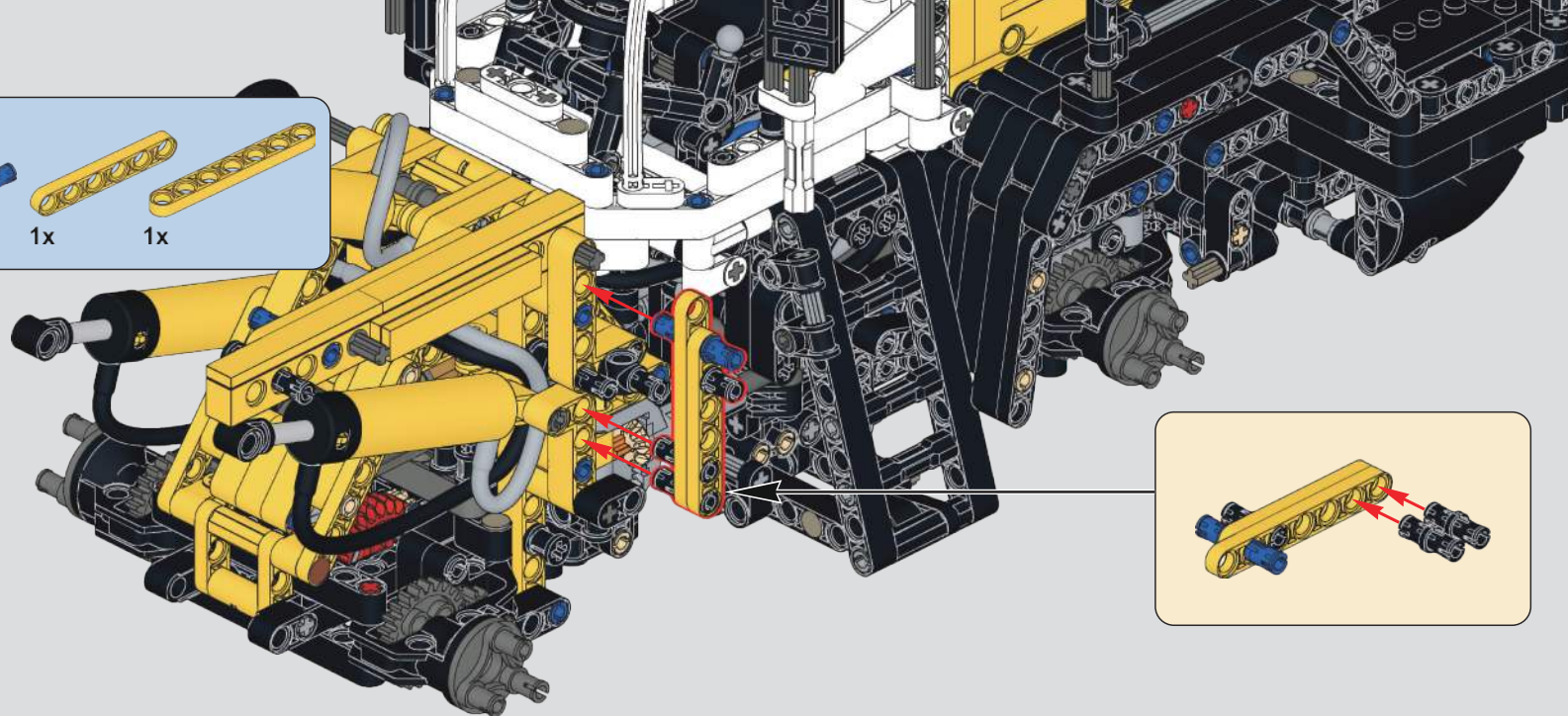

381

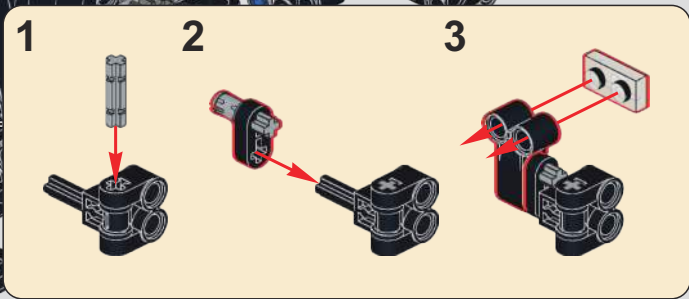
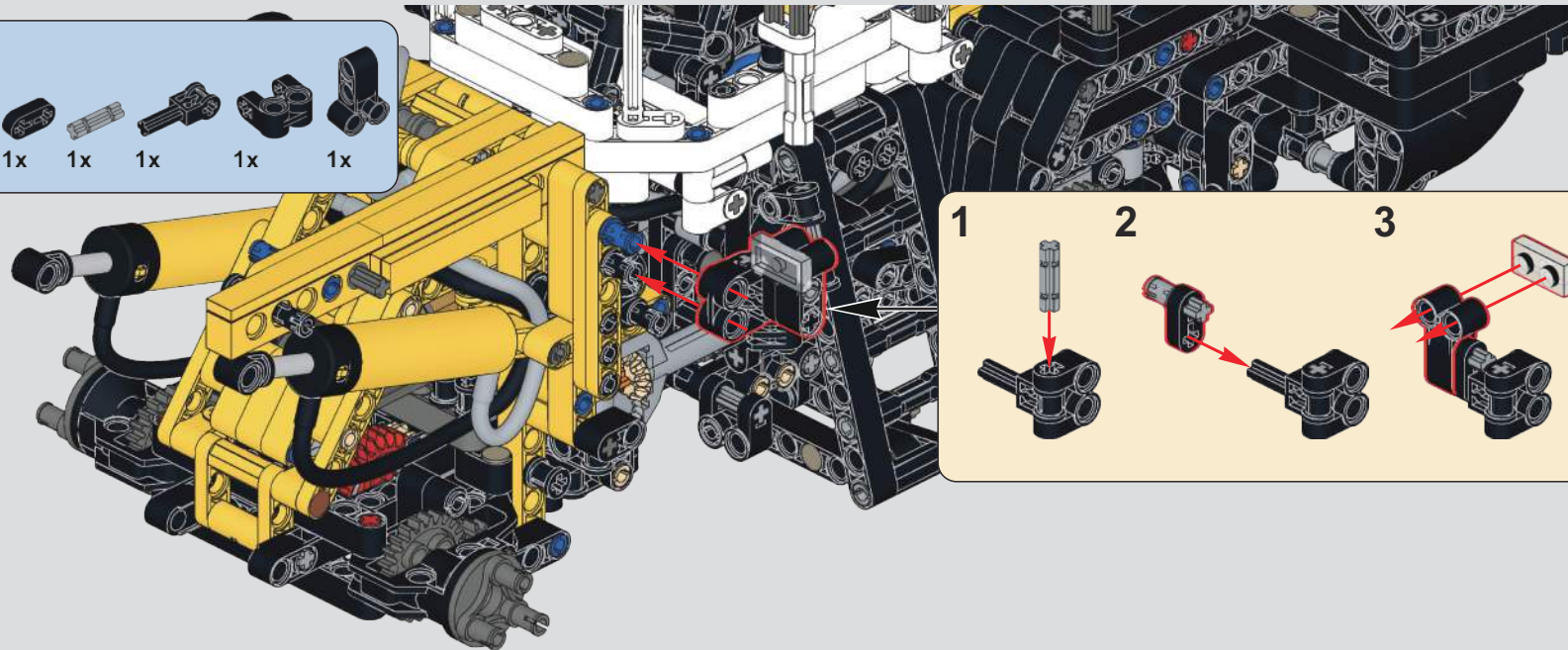

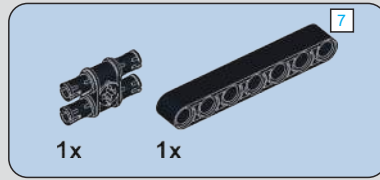

382

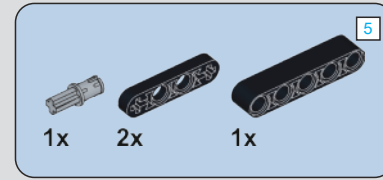
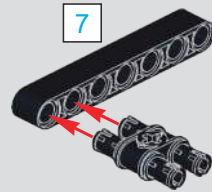

383

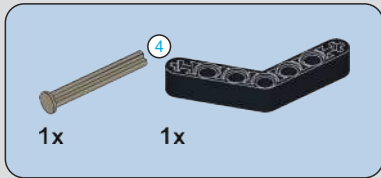
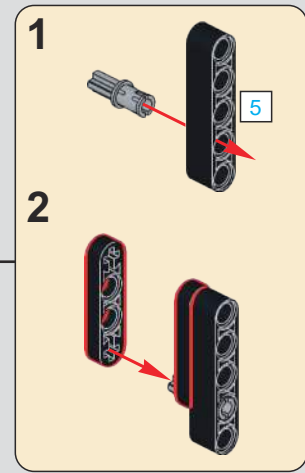
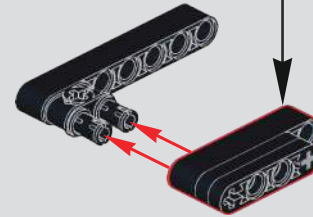

384

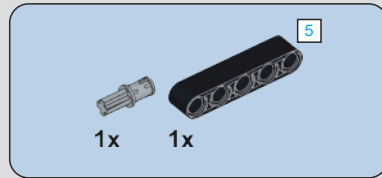

385

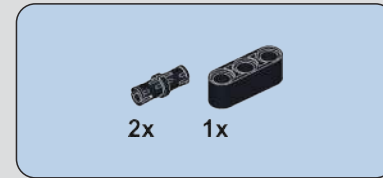
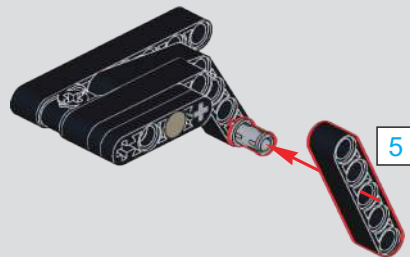

386



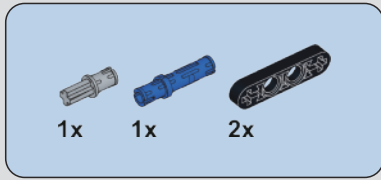

387

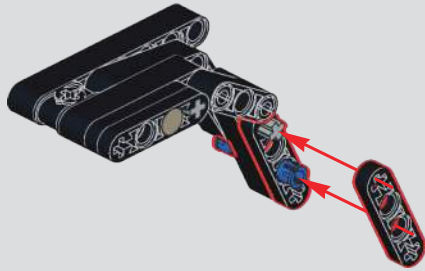

388

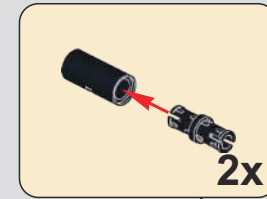
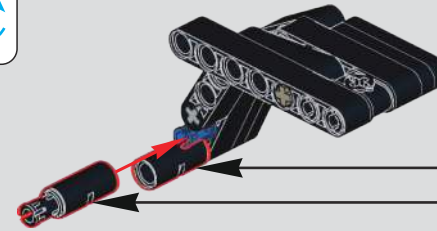

389

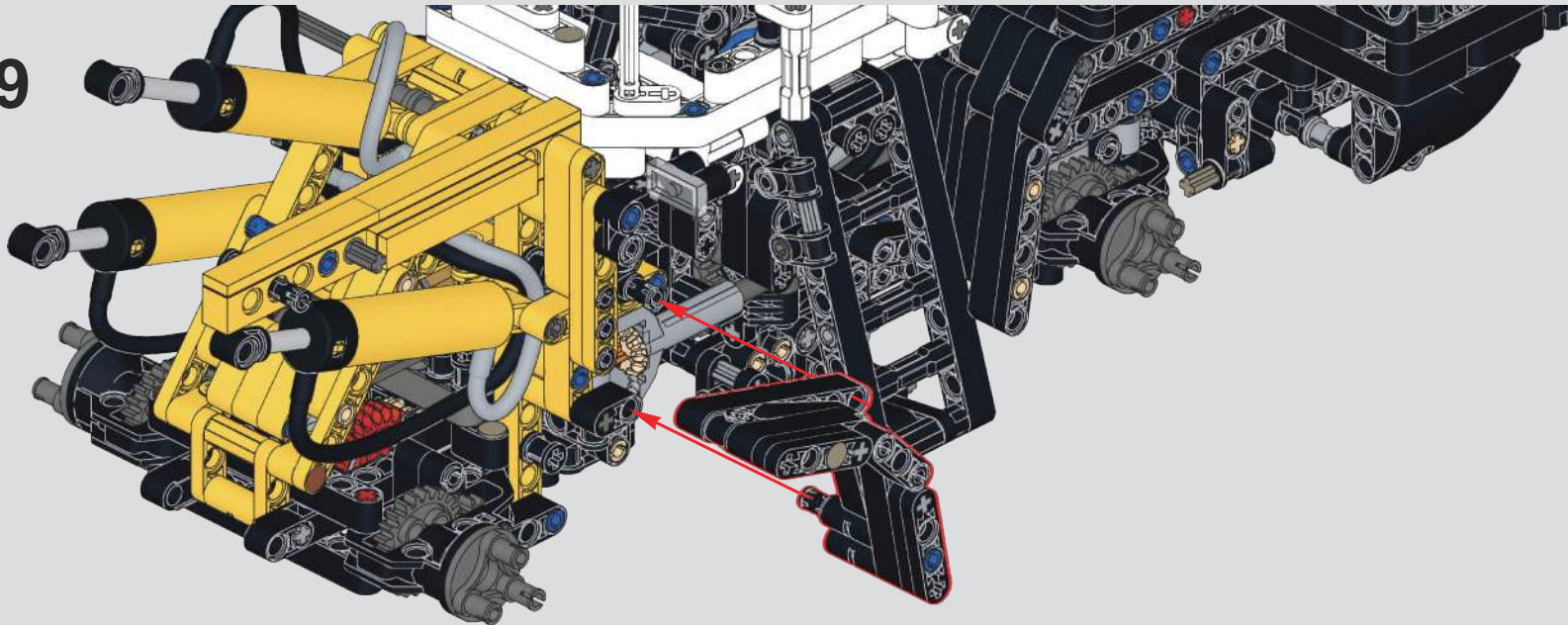

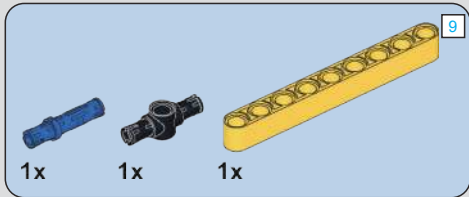

390

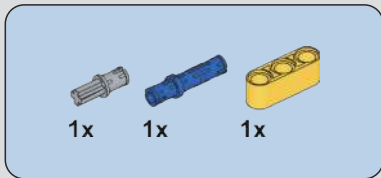
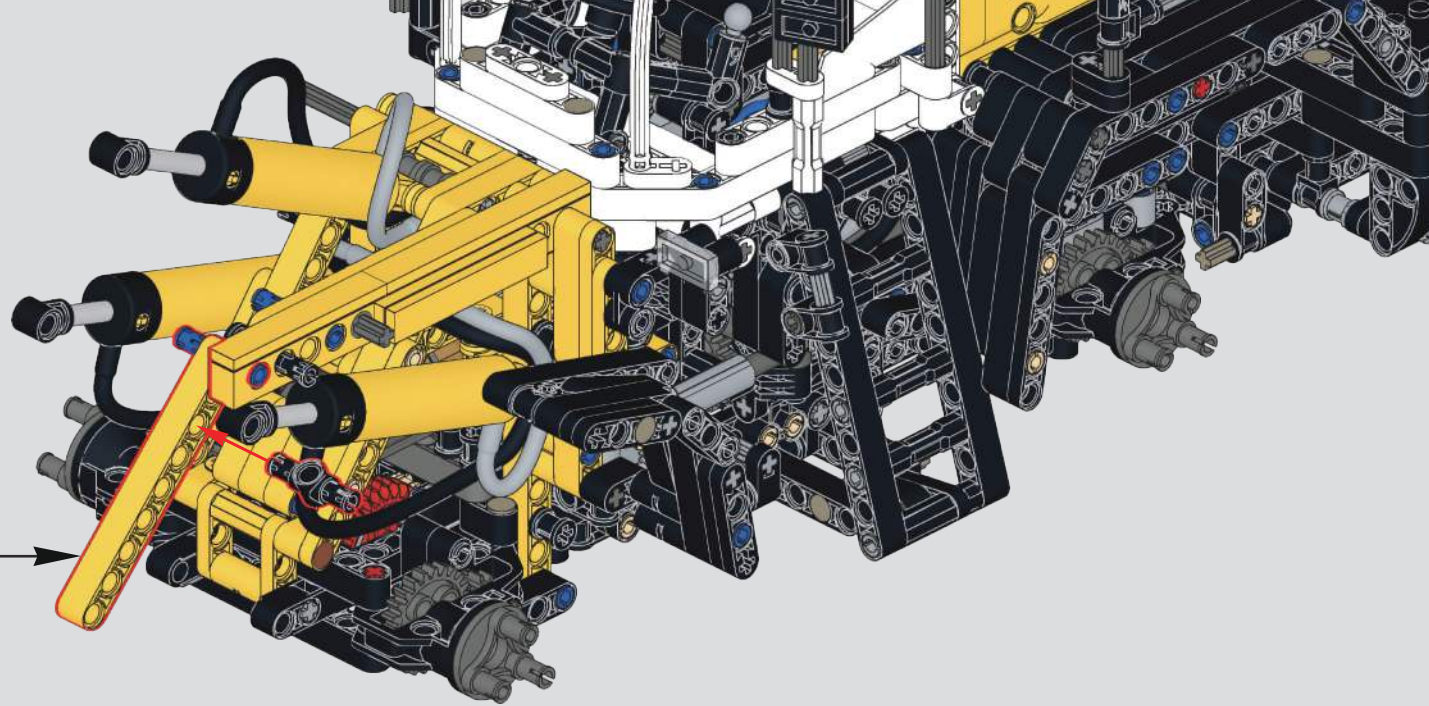
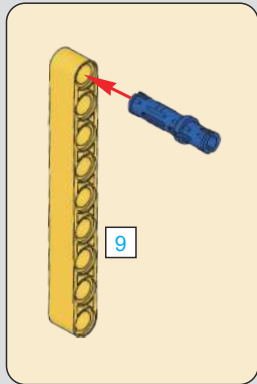

391

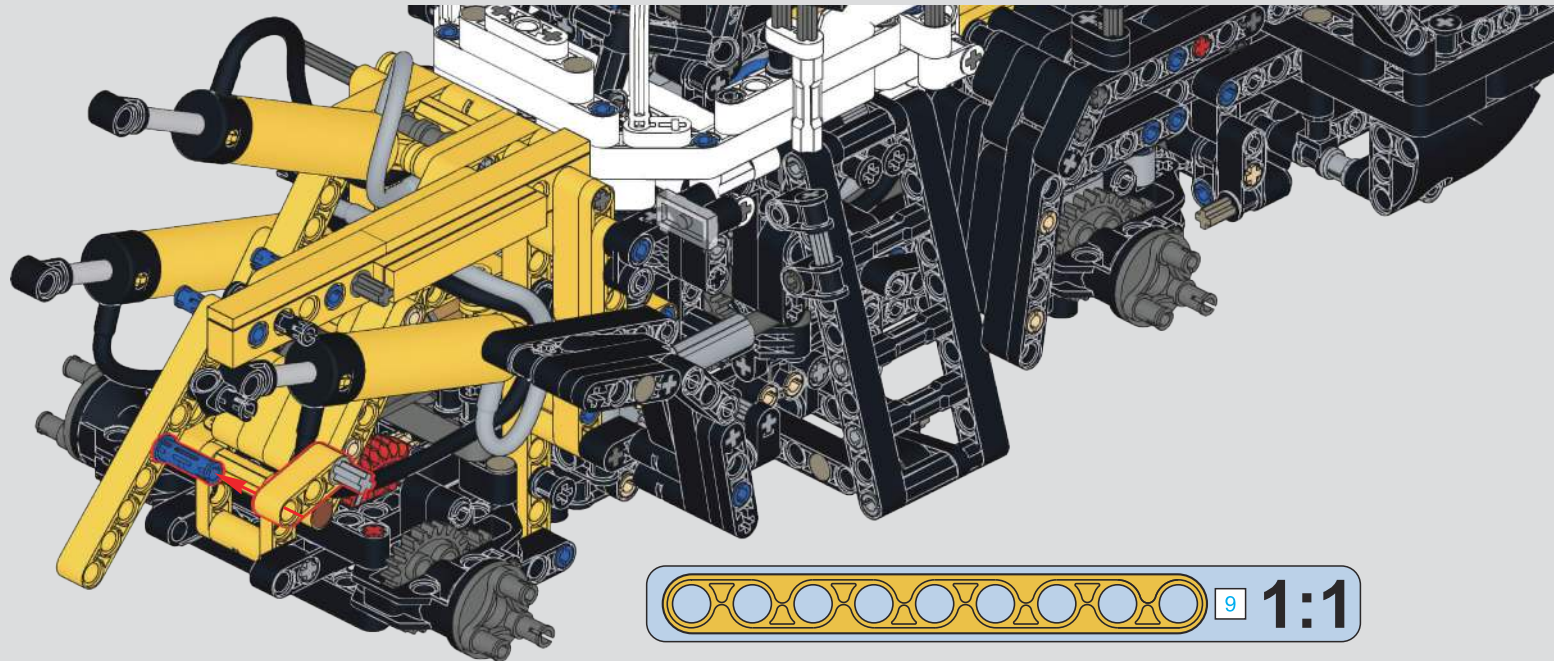

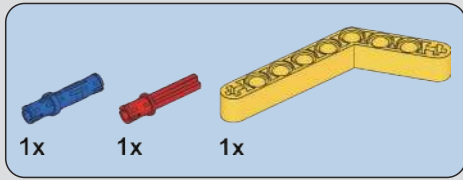

392

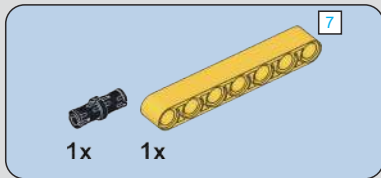
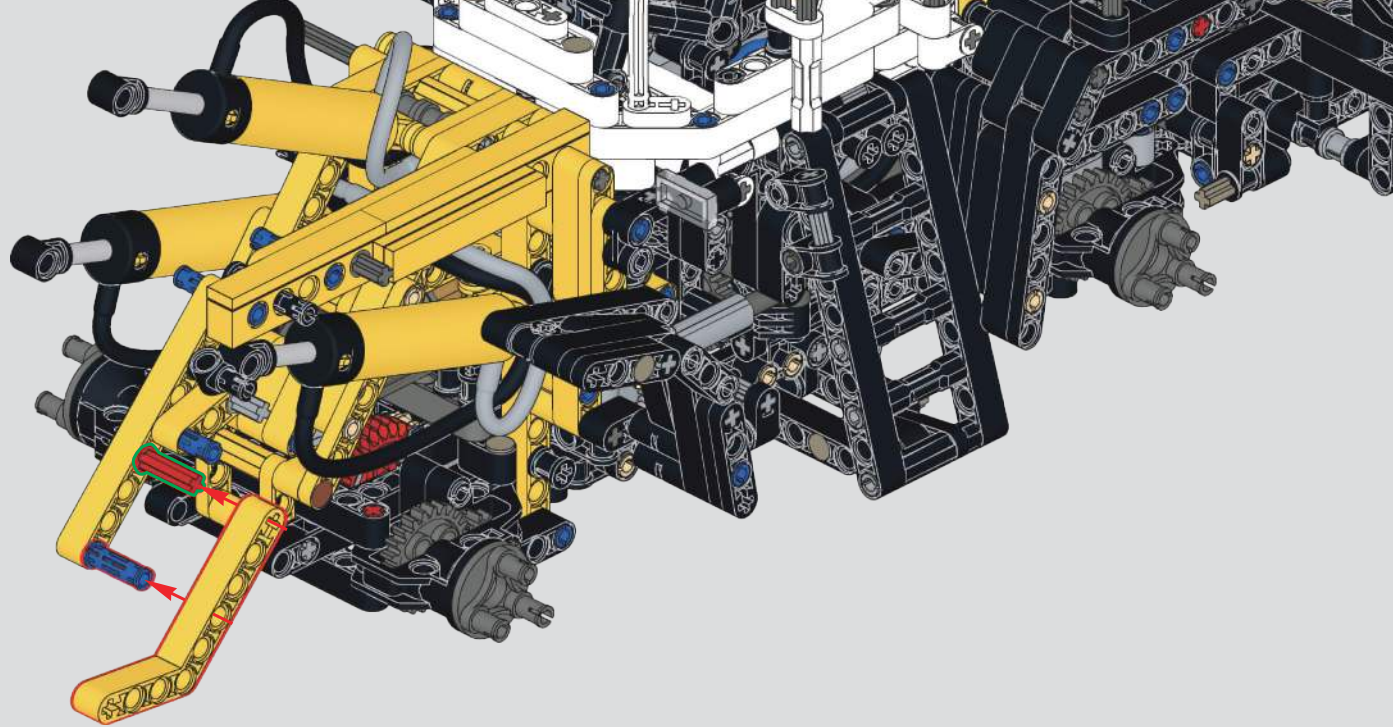

393

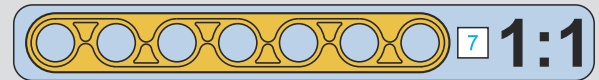
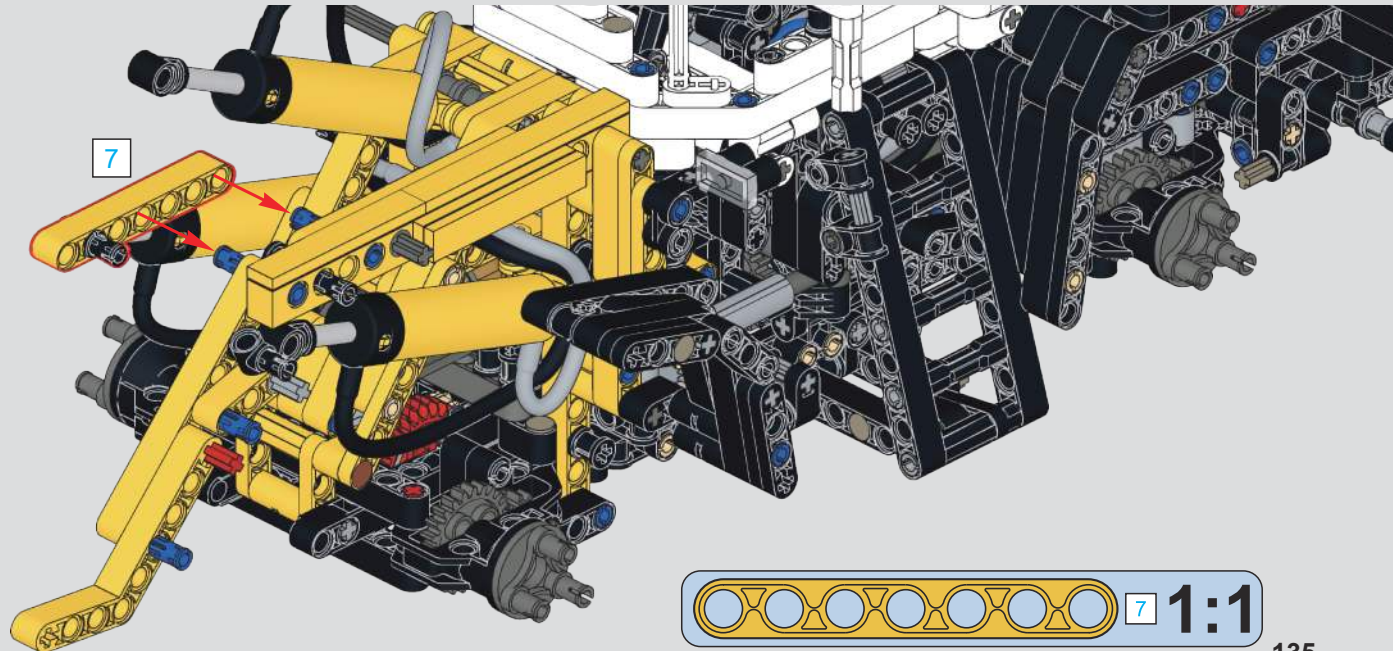

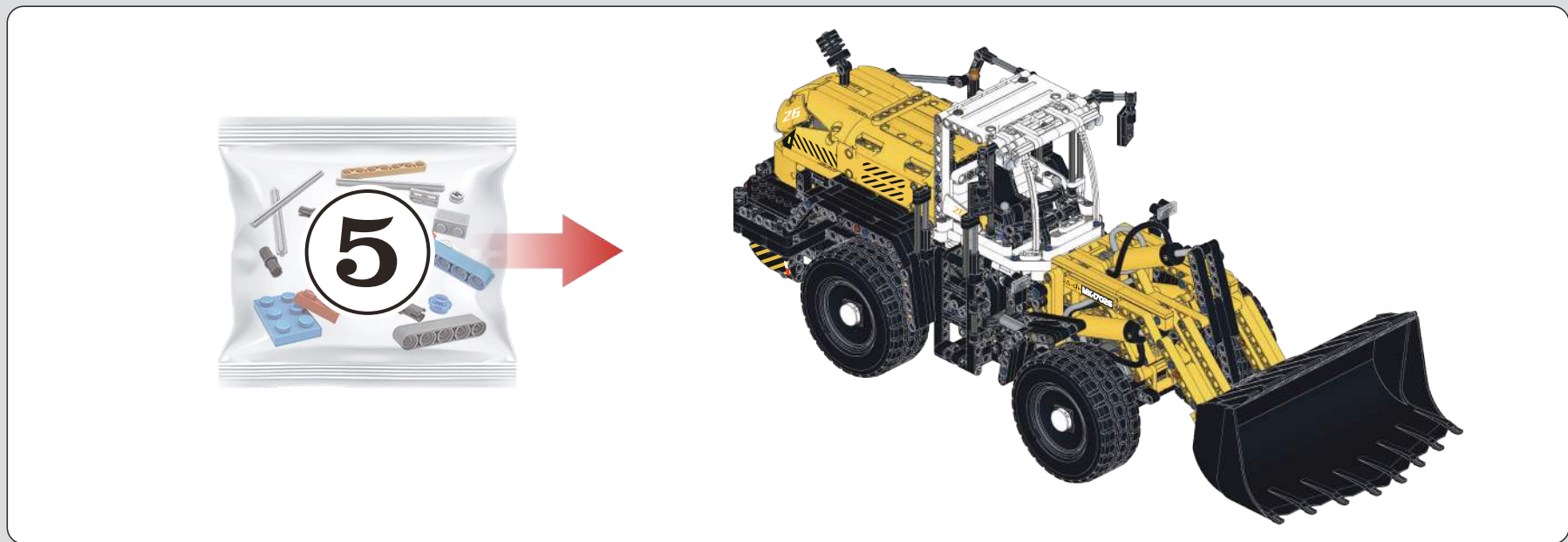
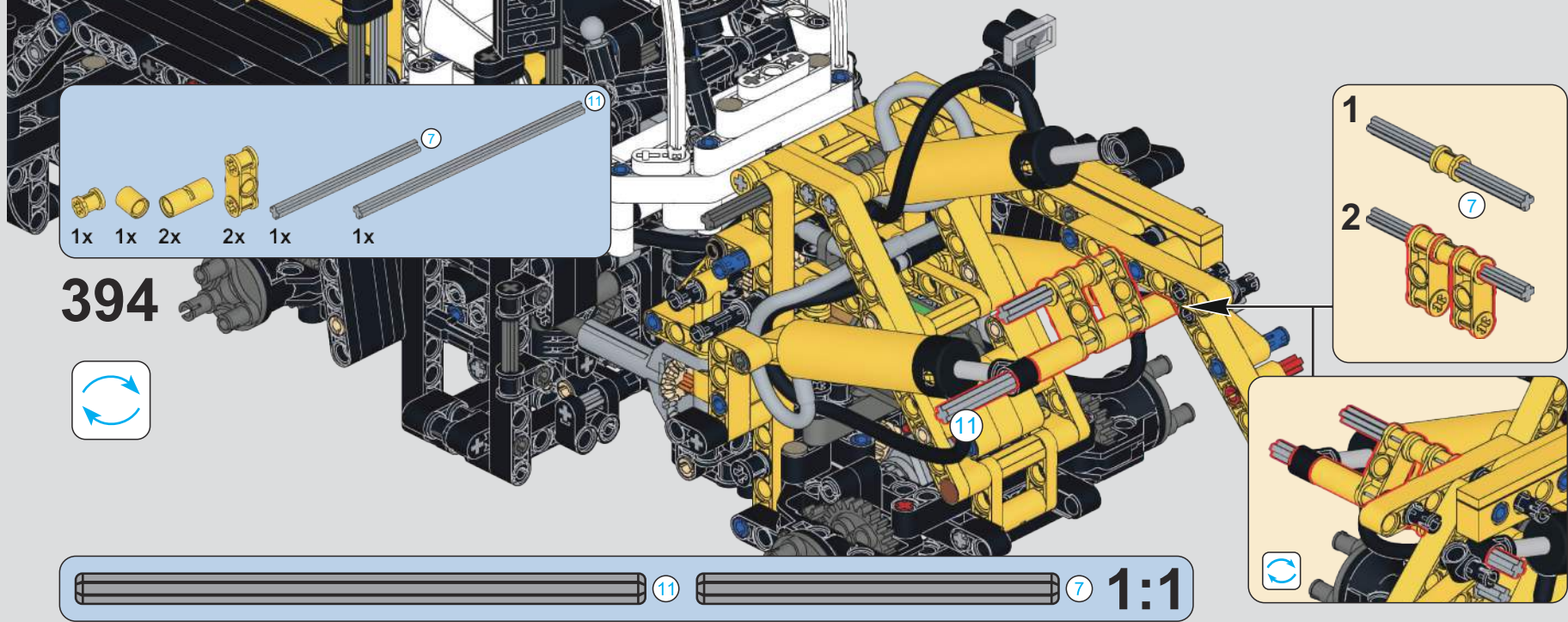

(光滑栓)
(Technic Pin without Friction)

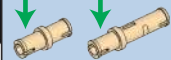

1x 1x 1x

395

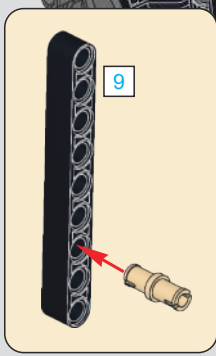

9

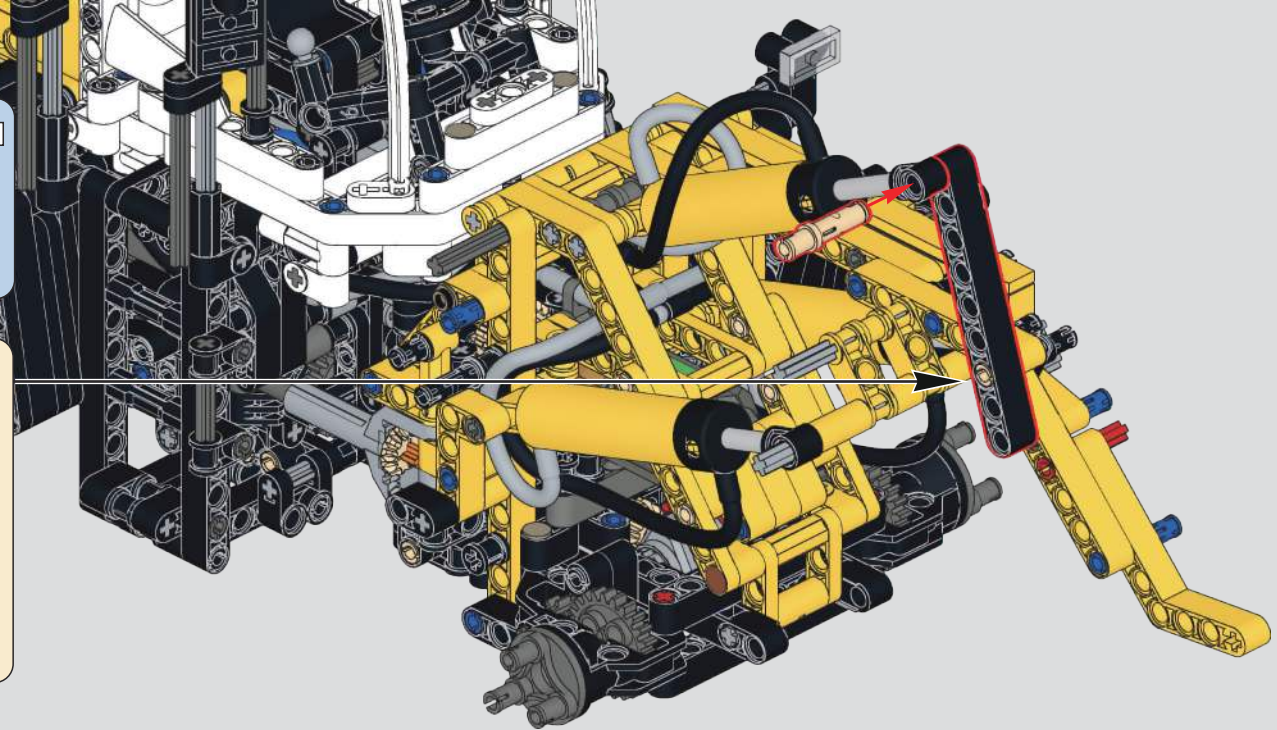

(光滑栓)(Technic Pin without Friction)

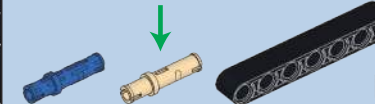

2x 1x 1x 1x

396

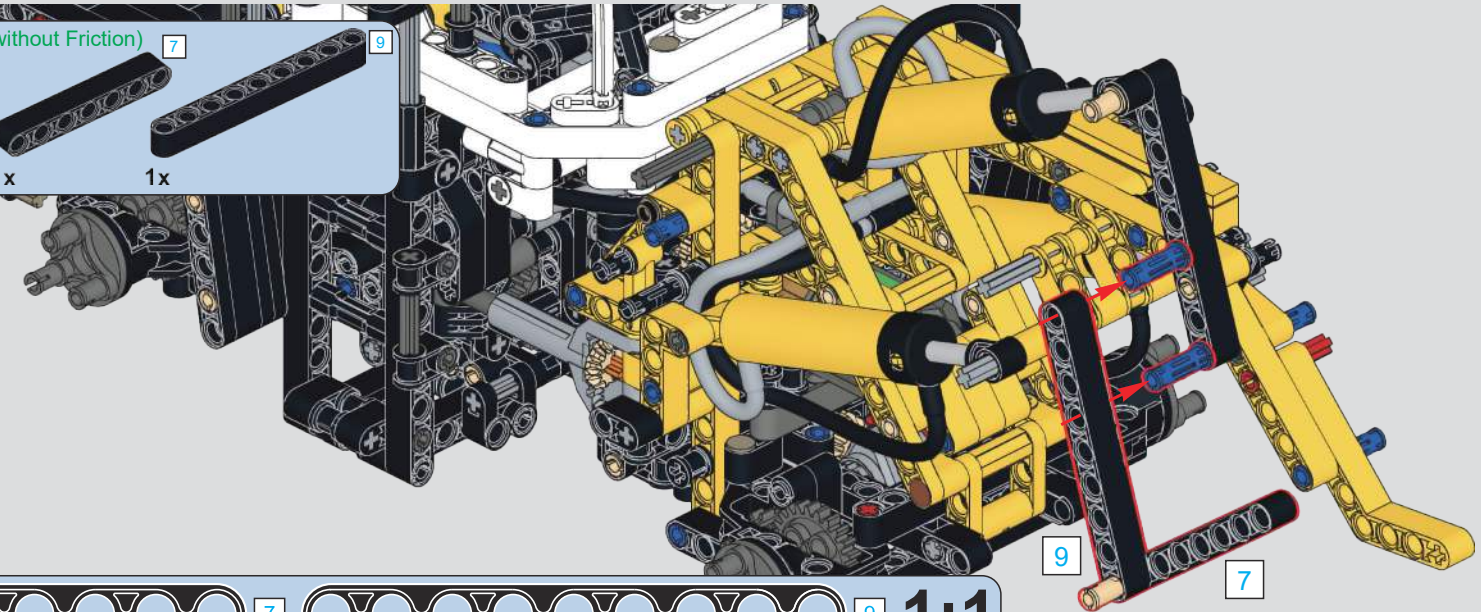

9

7



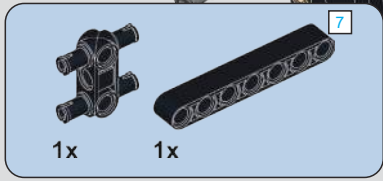

397

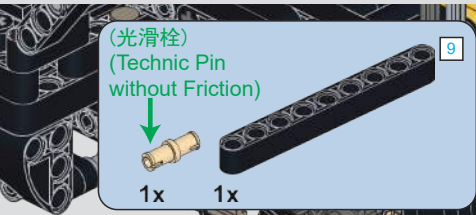
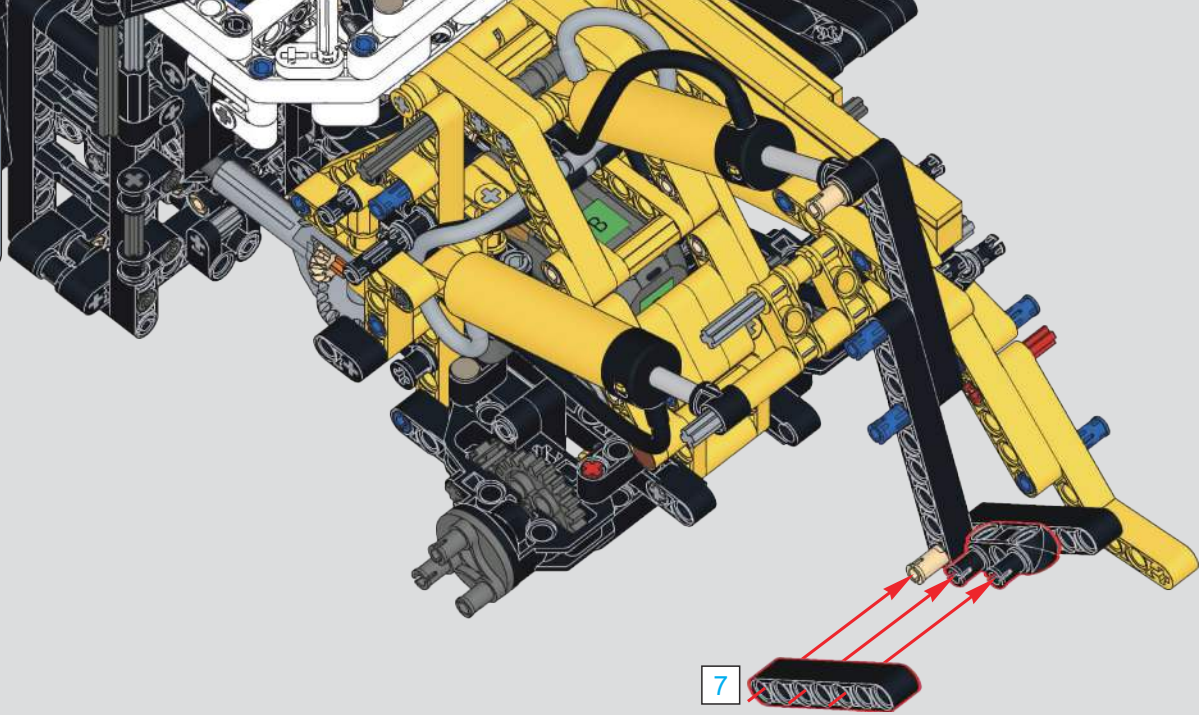

398

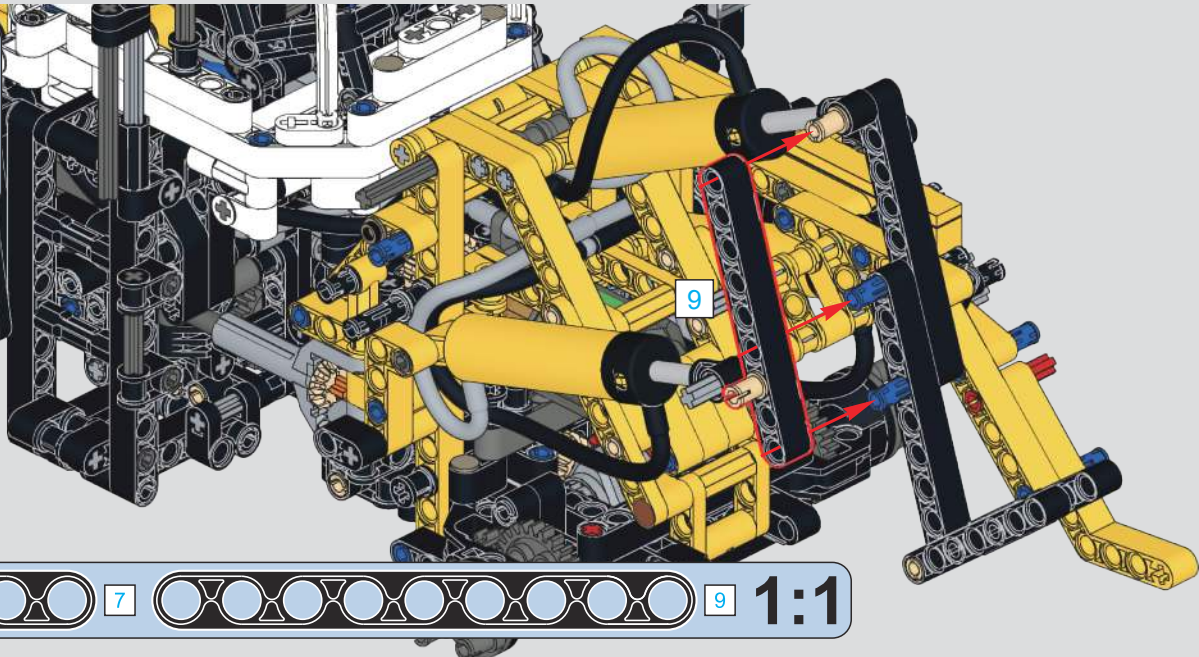

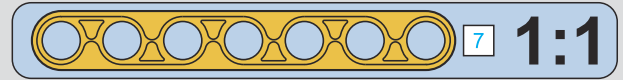
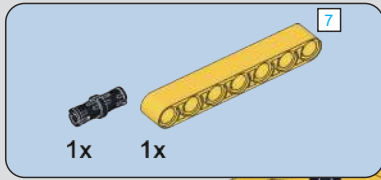

399

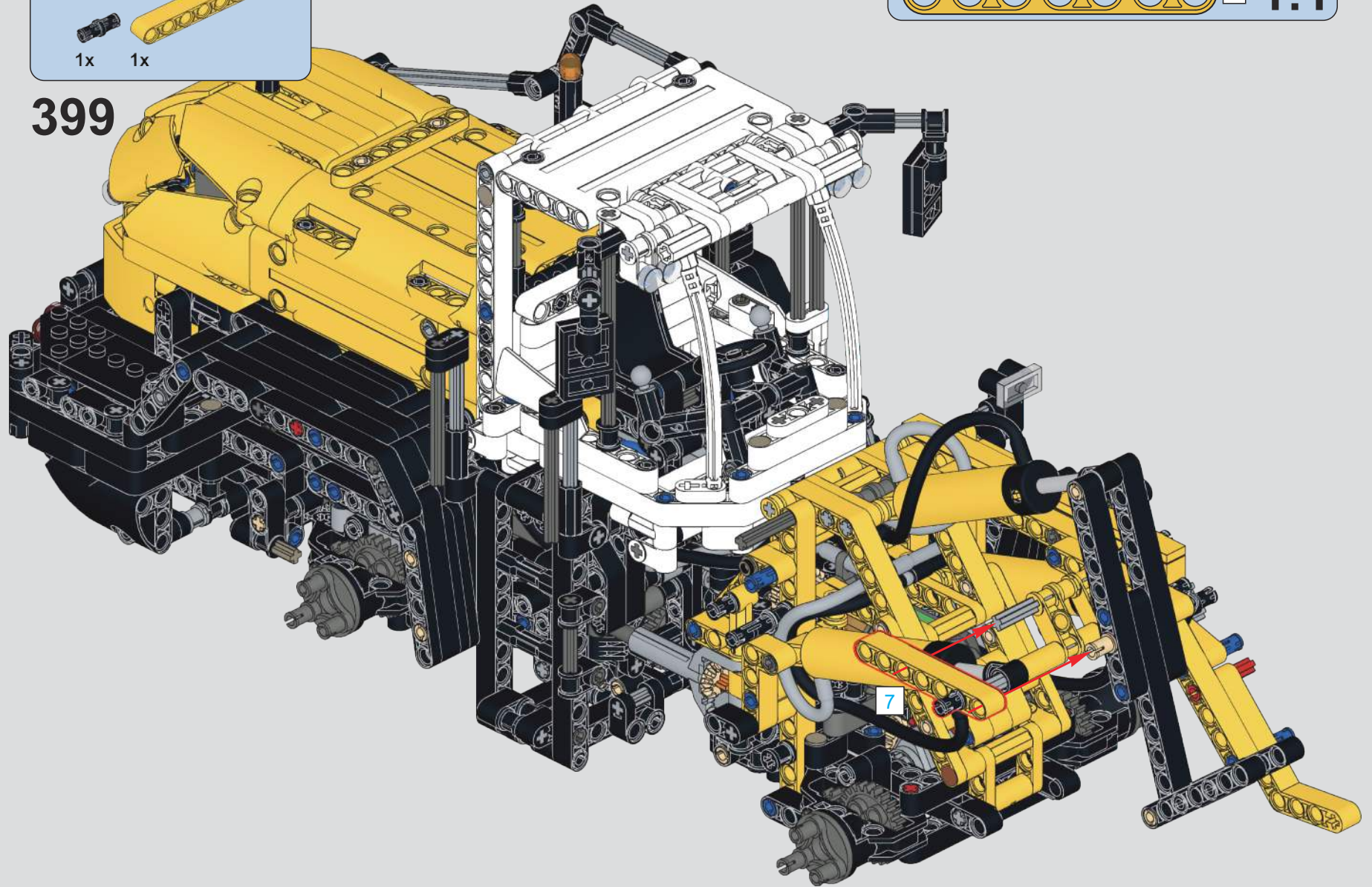

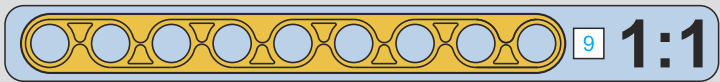
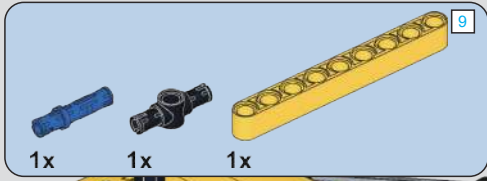

400

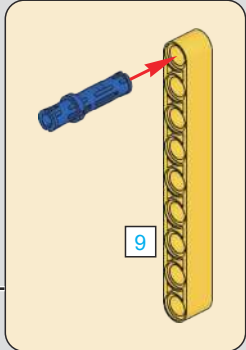
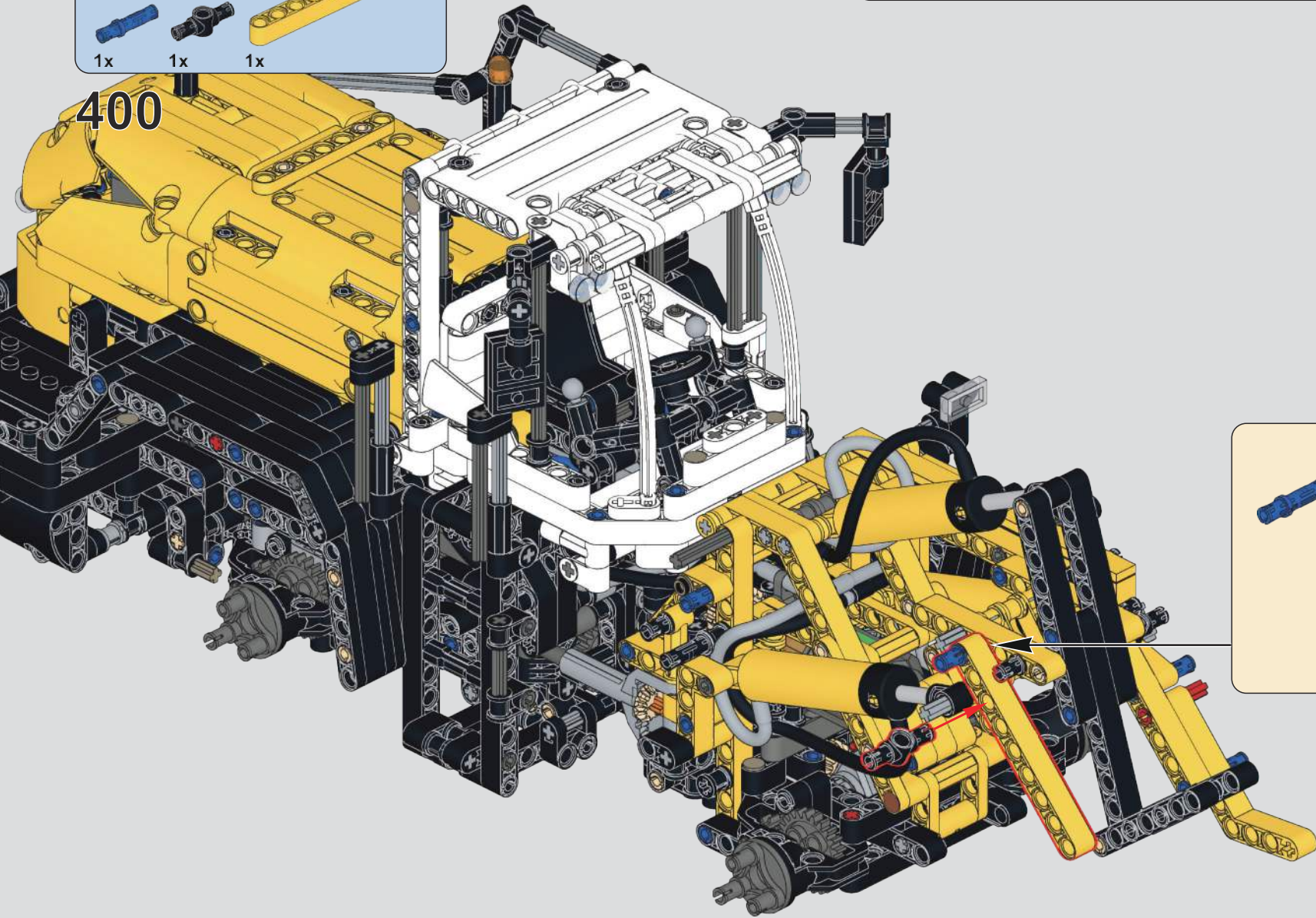

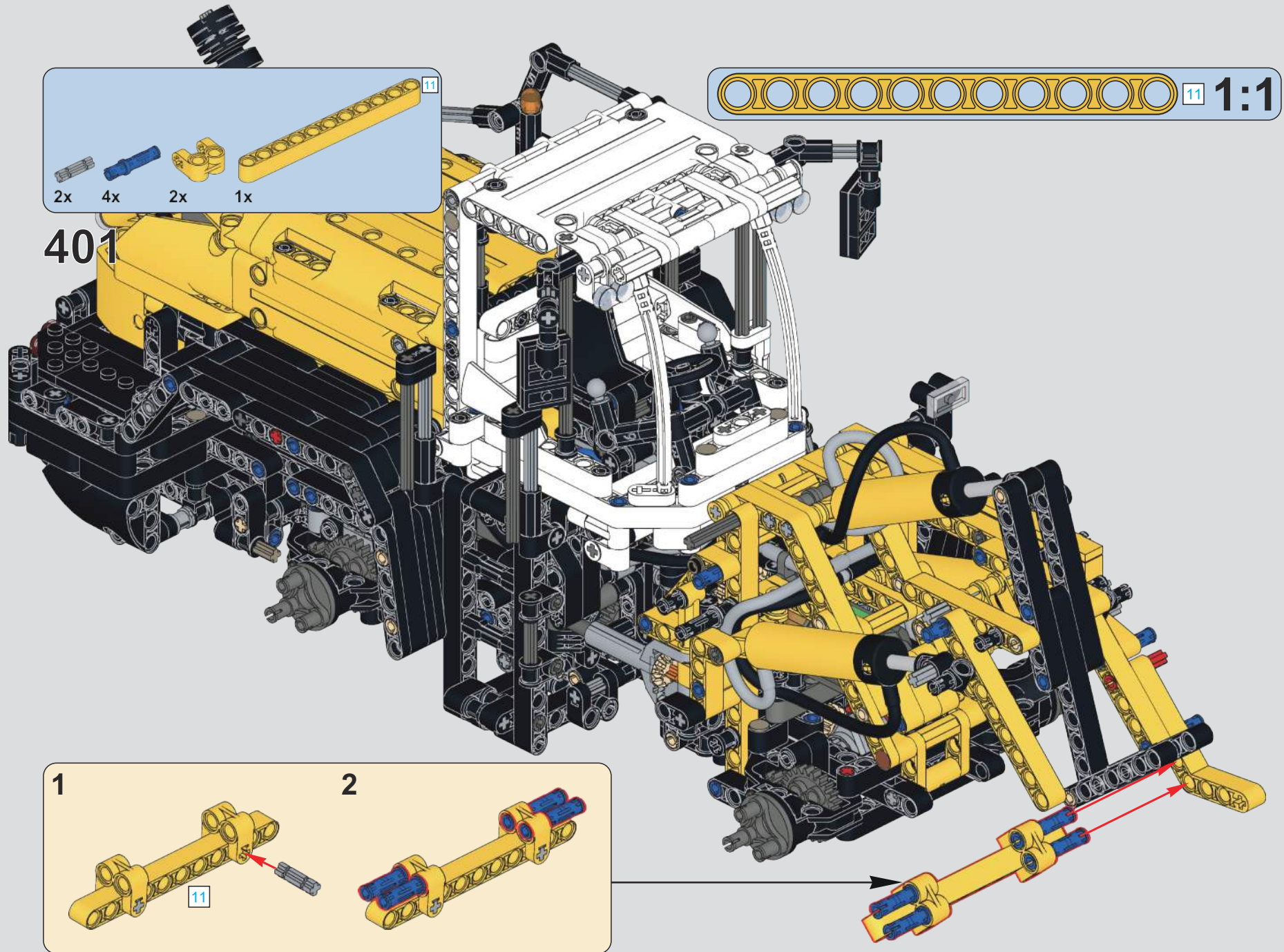

401

2x 4x 2x 1x

11 1:1

1

2

11

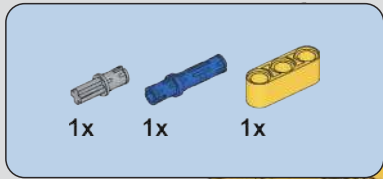

402

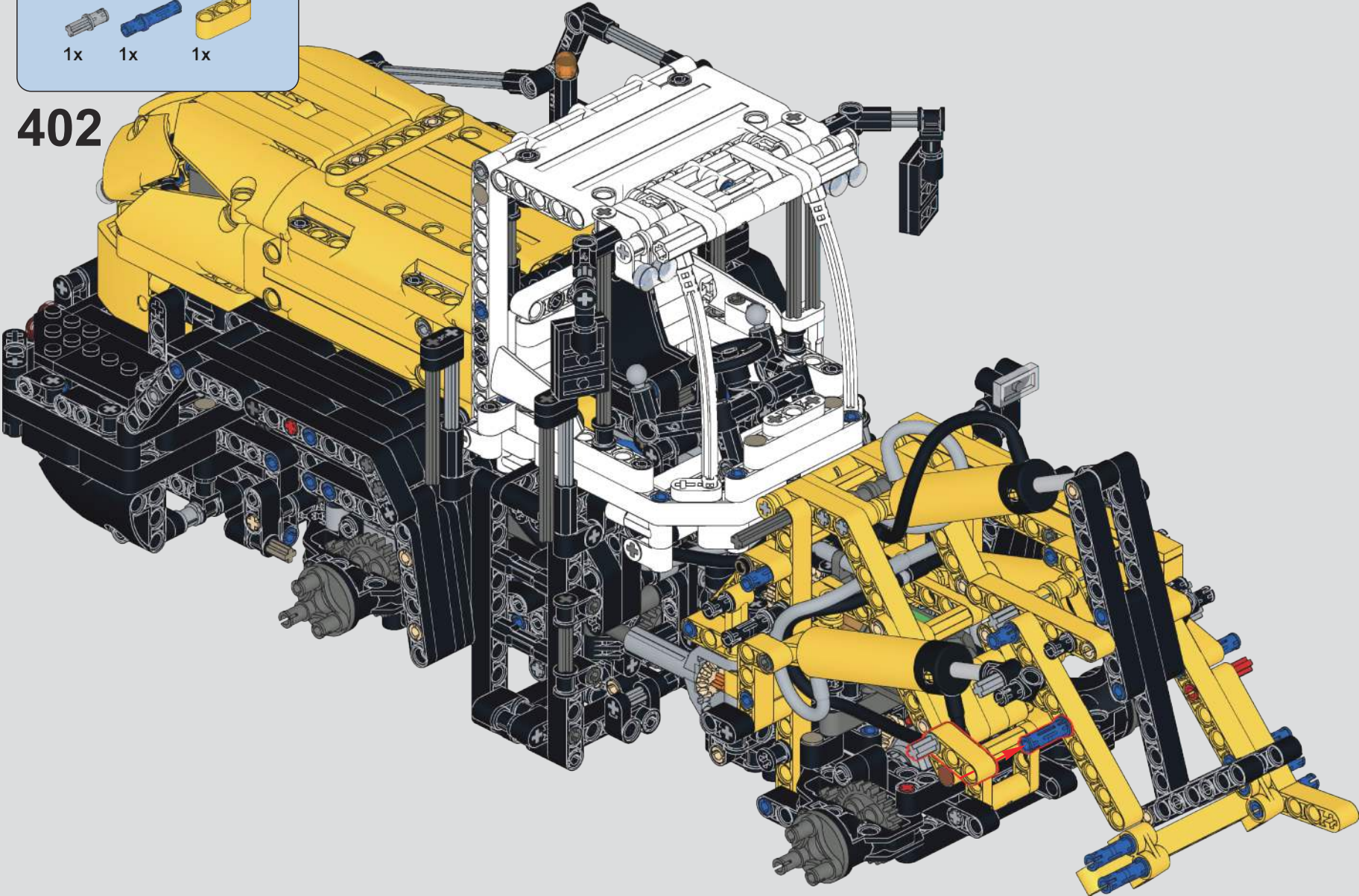

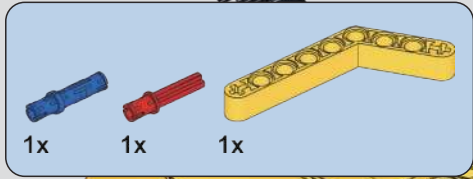

403

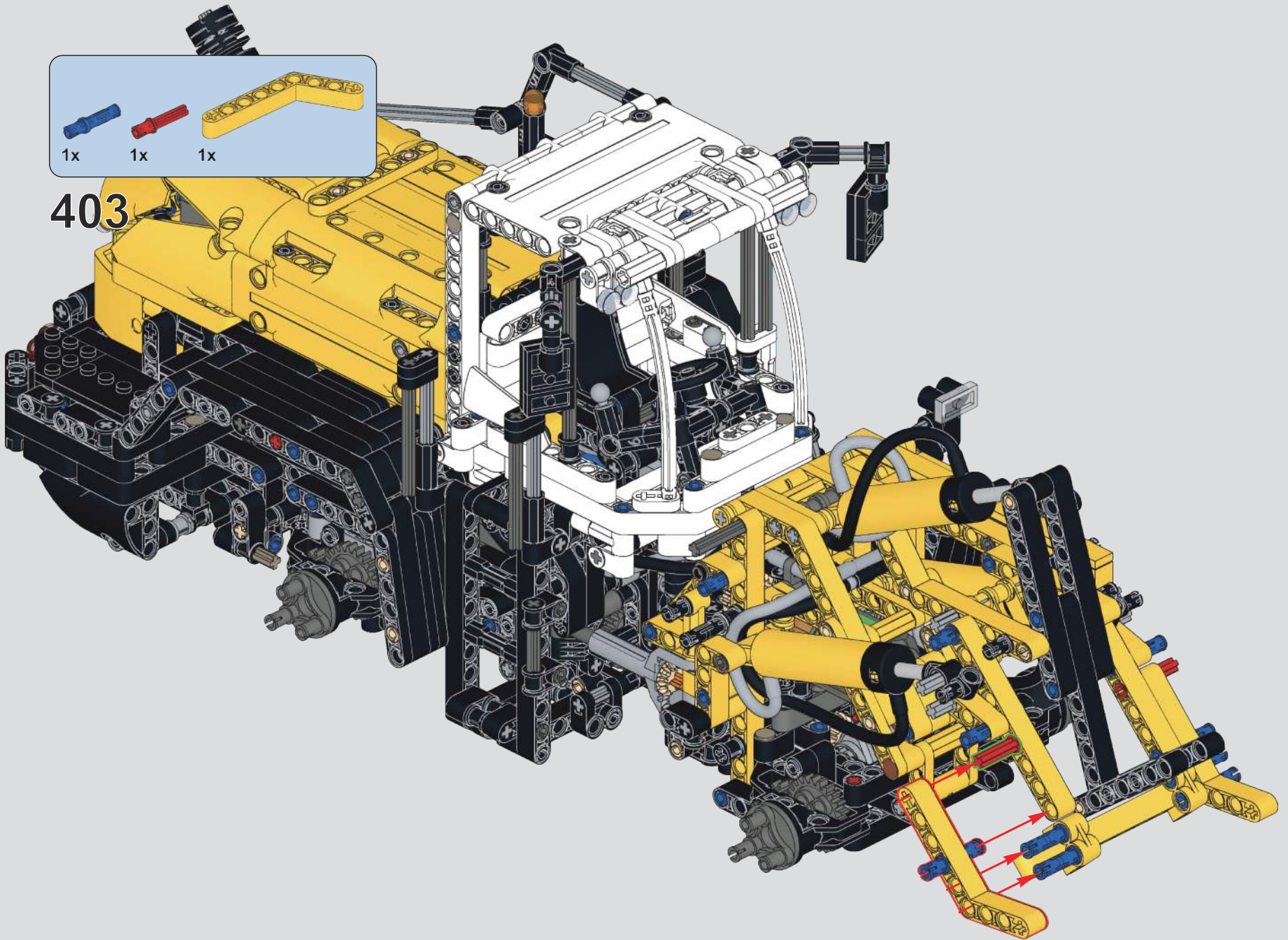

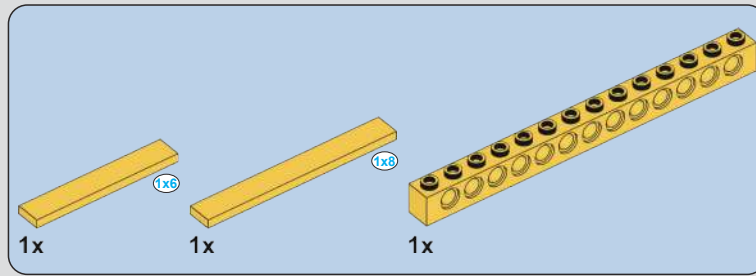
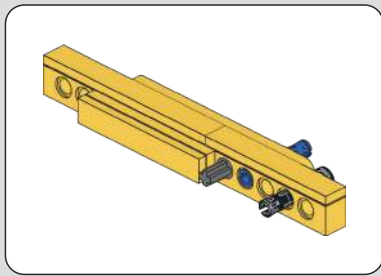

404

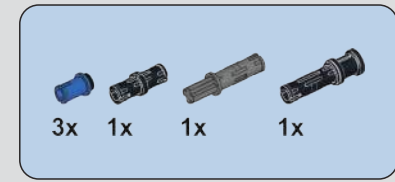
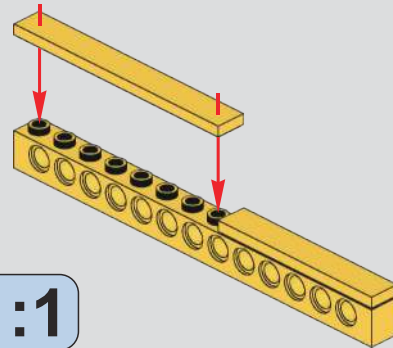

405

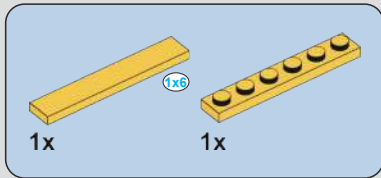
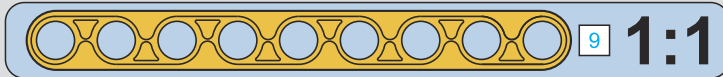
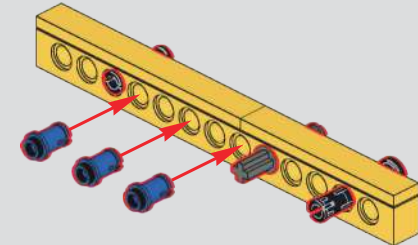

406

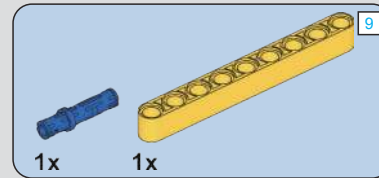
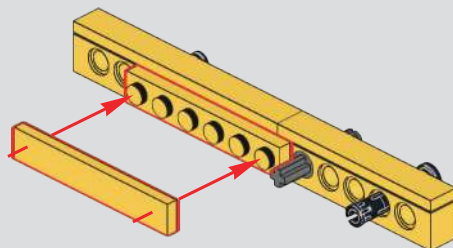

407

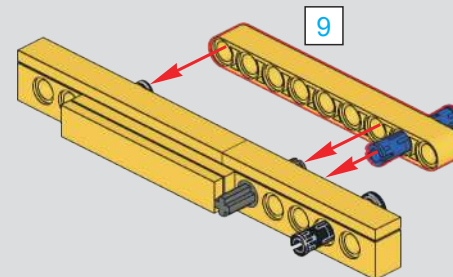

408

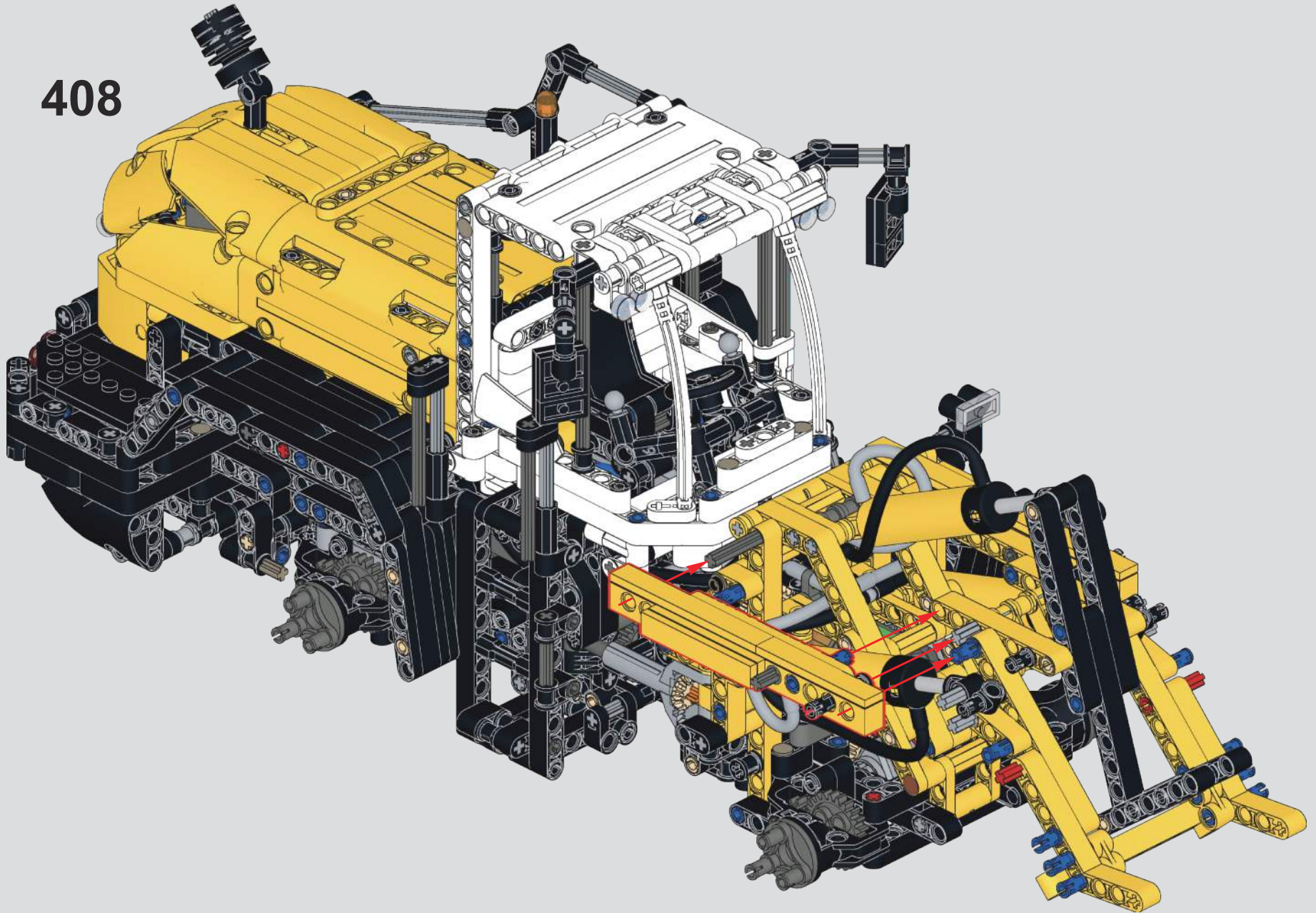

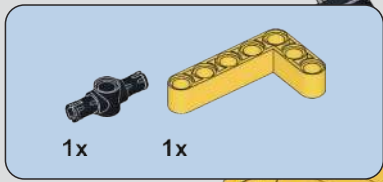

409

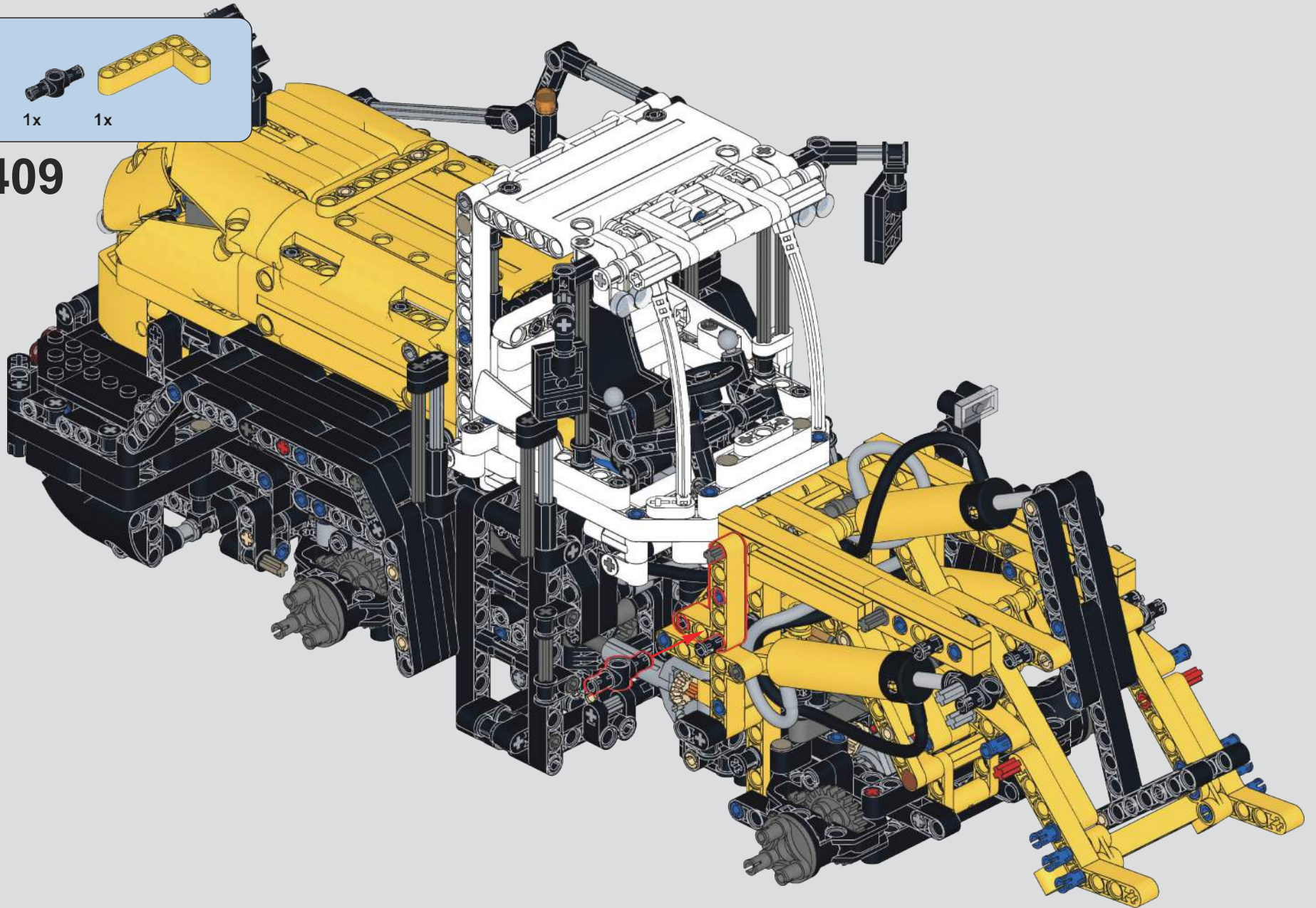

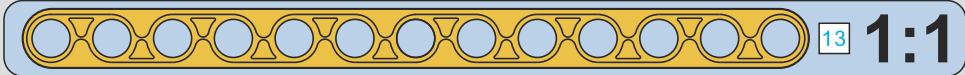
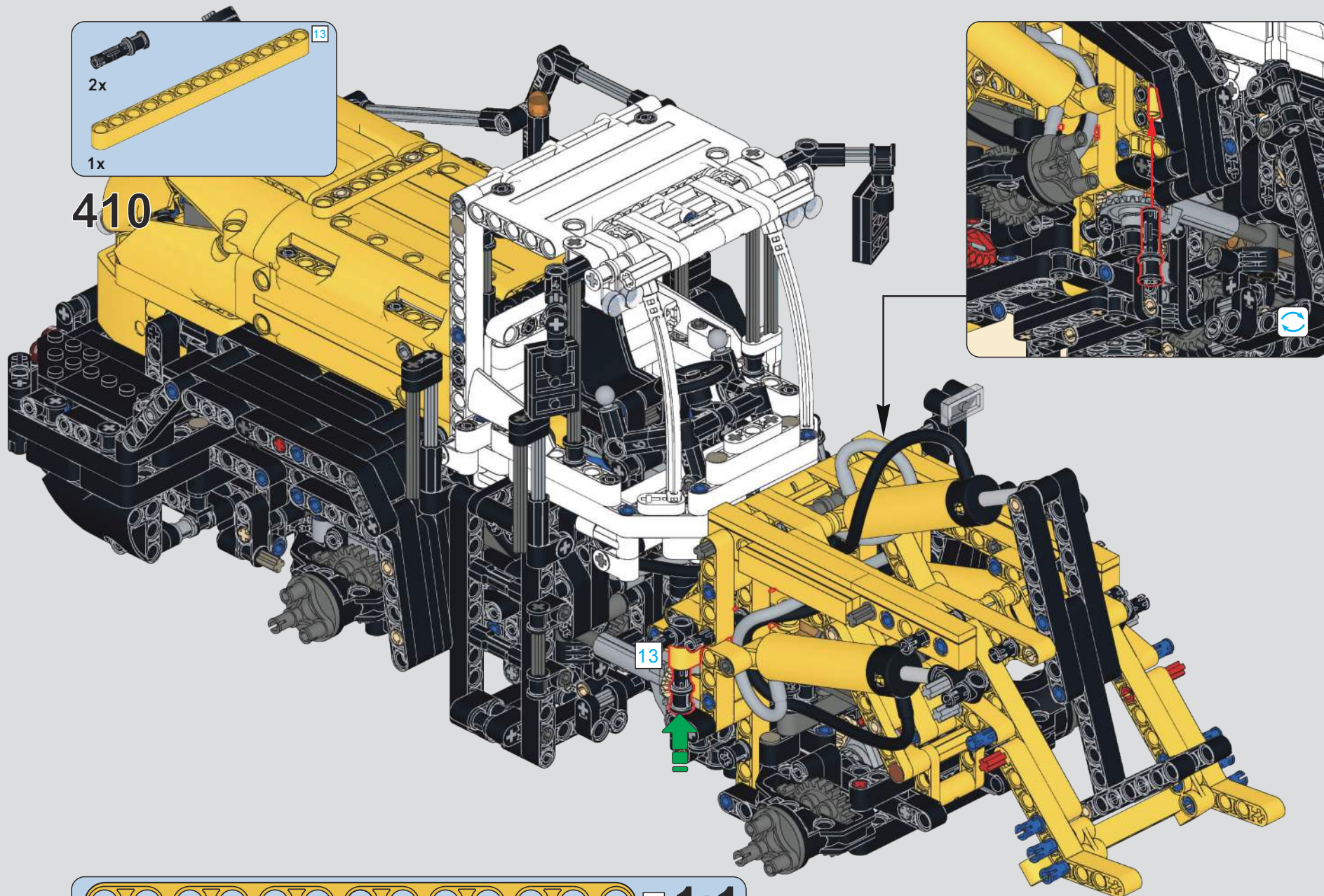

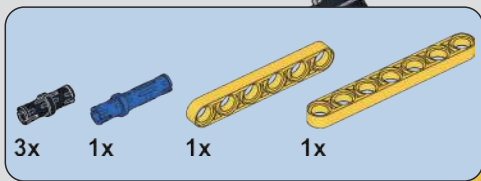

411

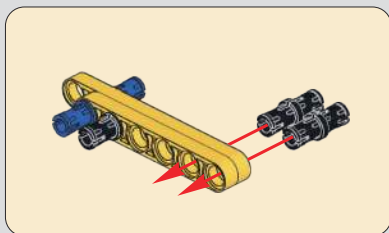
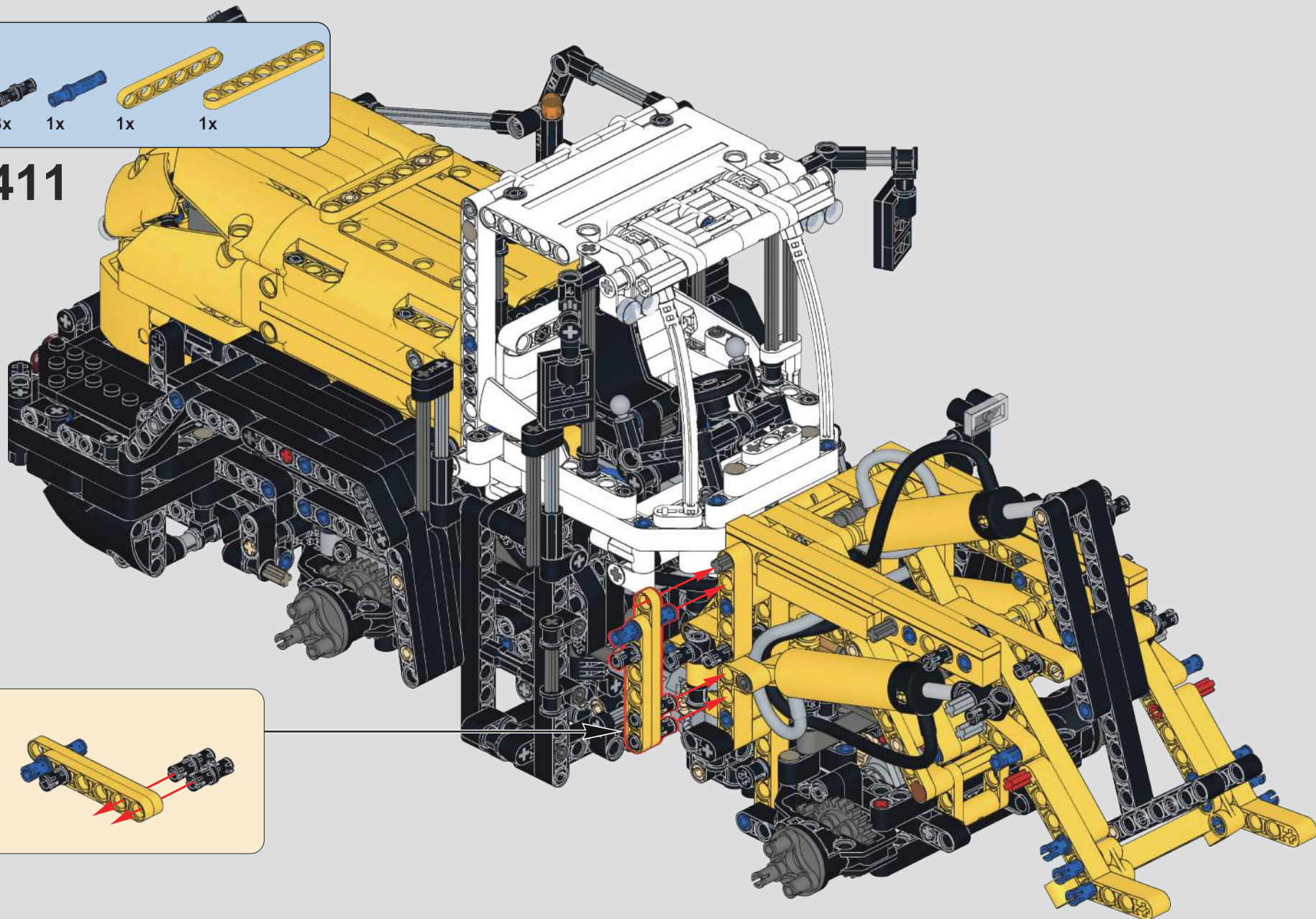



412

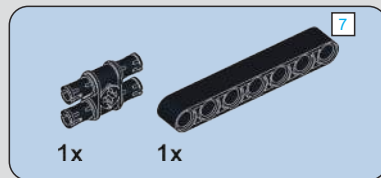
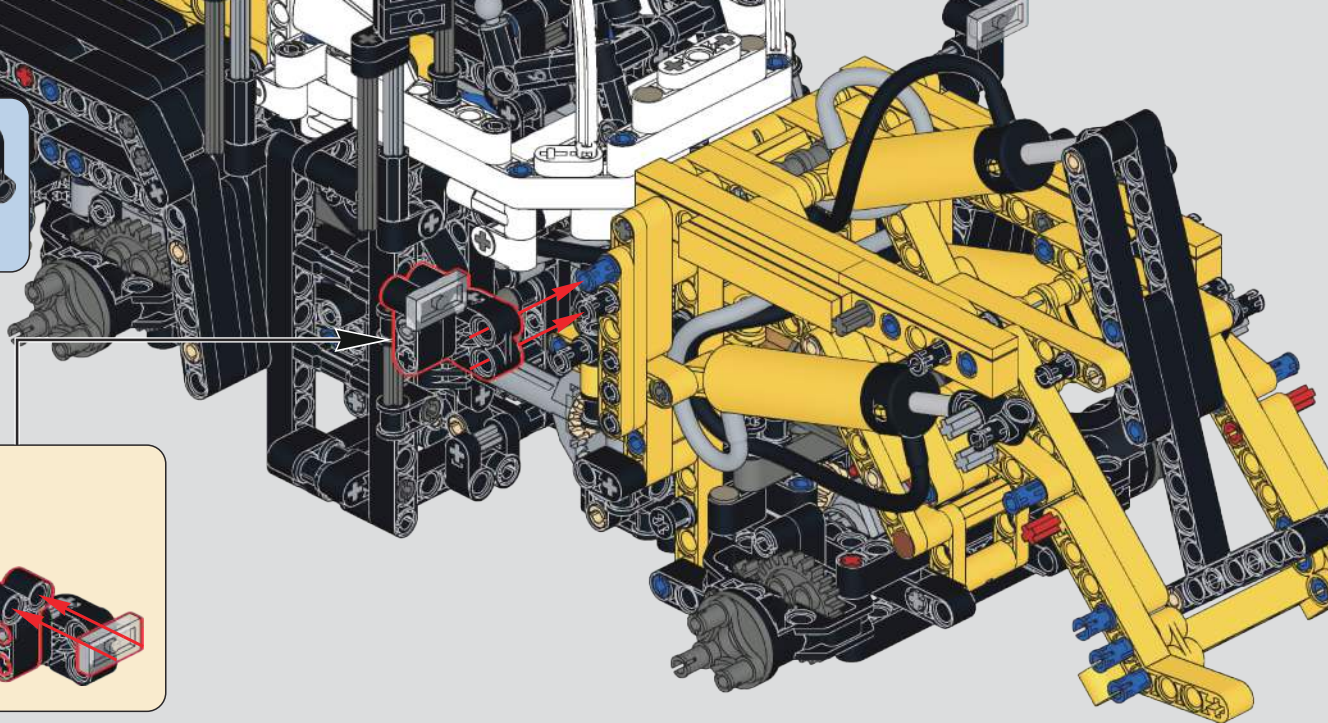
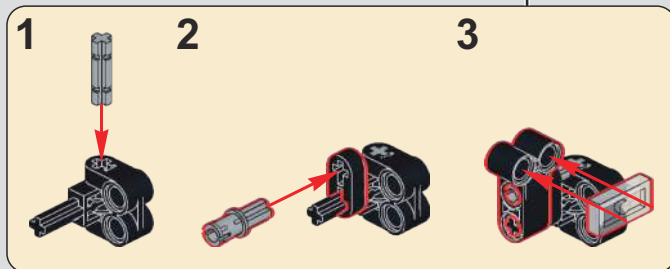

413

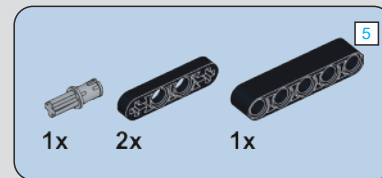
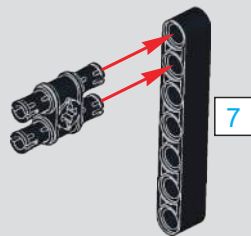

414

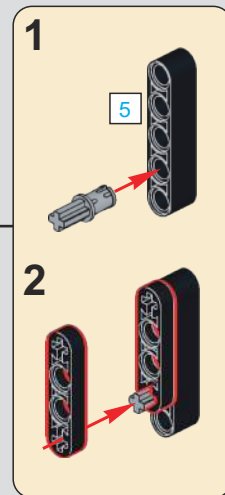
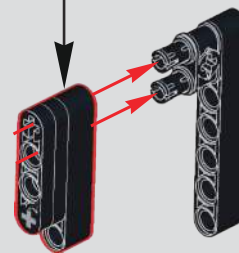

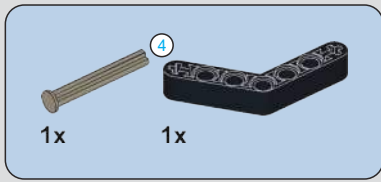

415

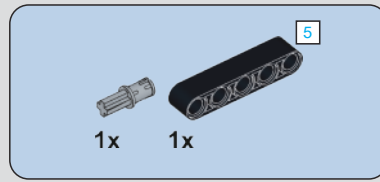
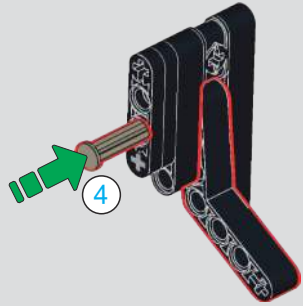

416

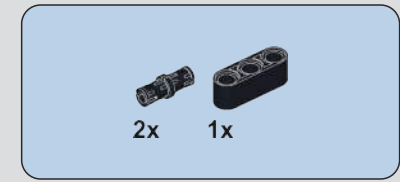
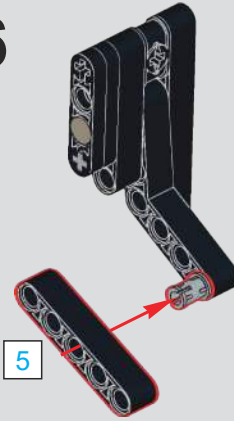

417

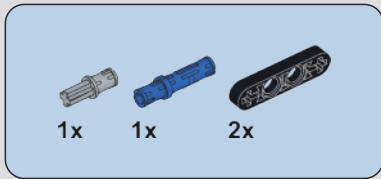
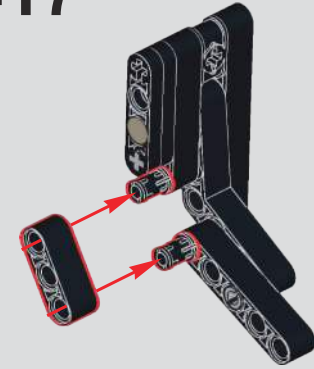

418

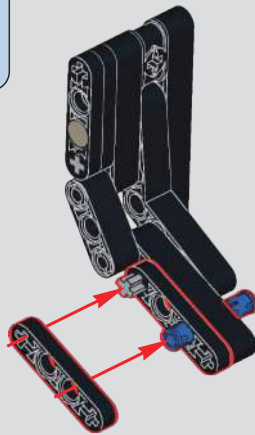

419

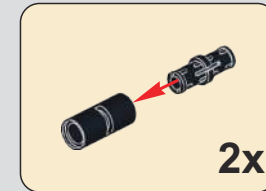
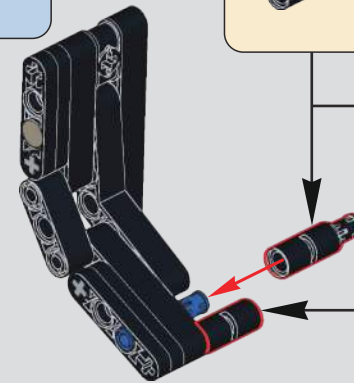

2x



420

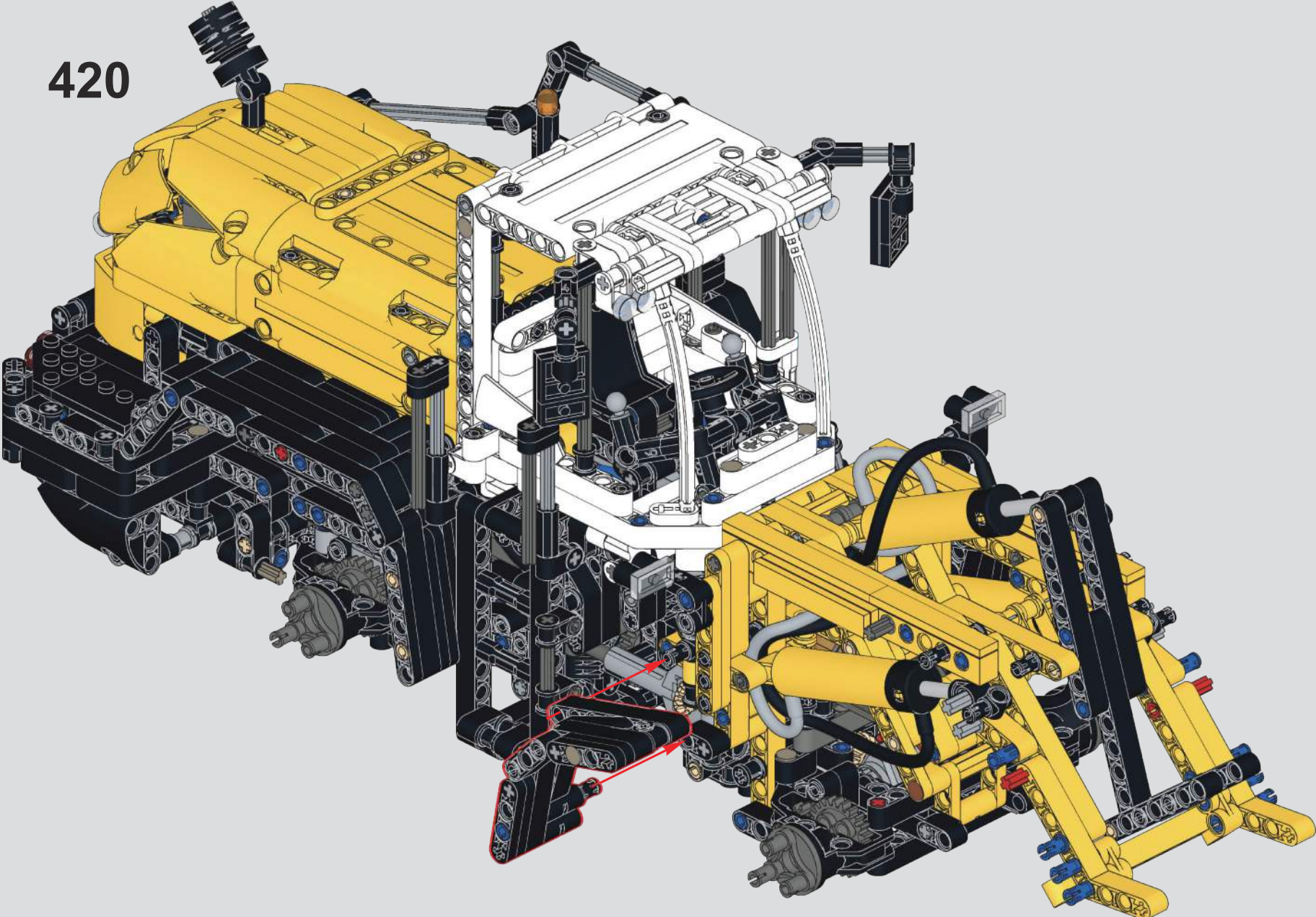

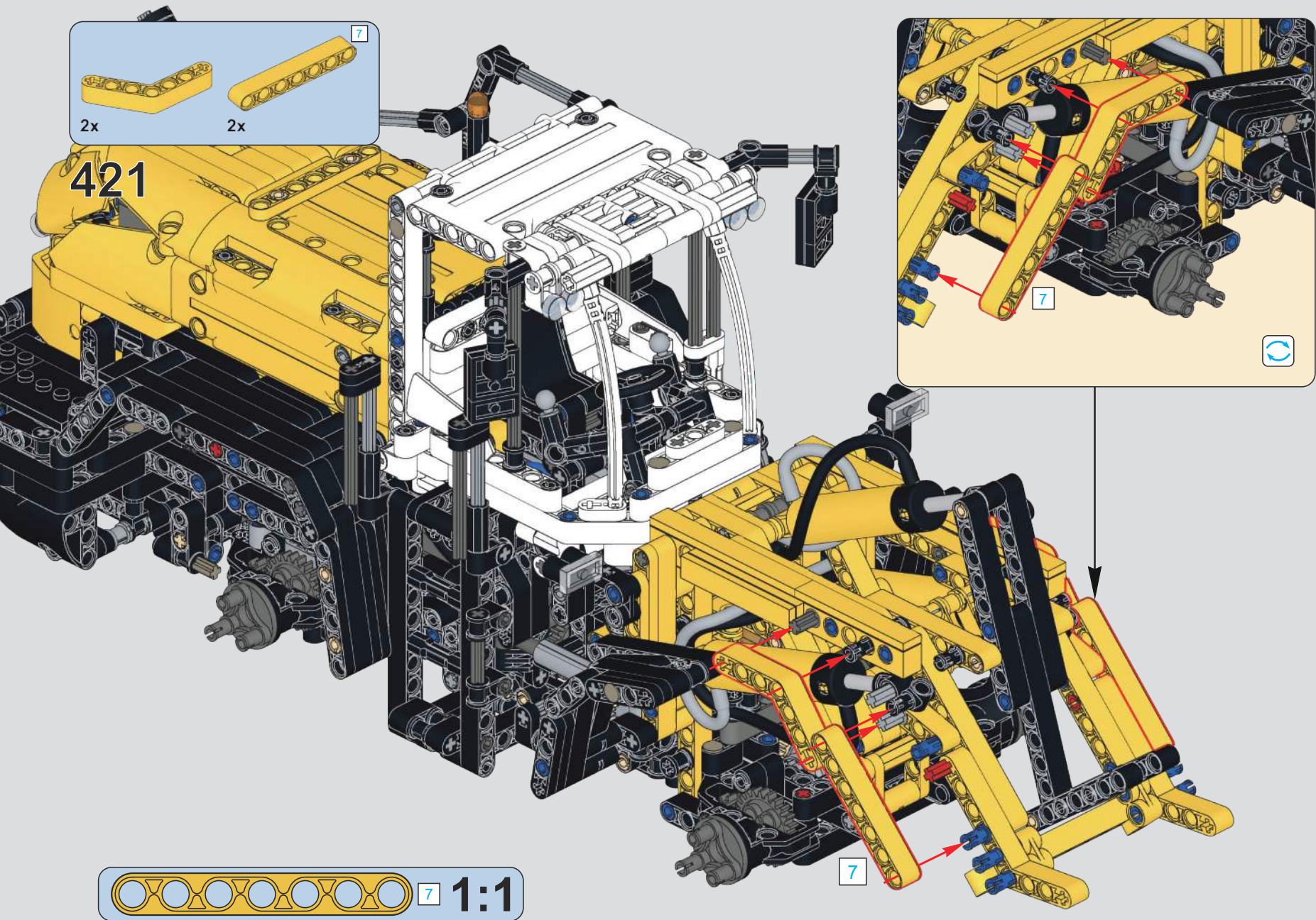

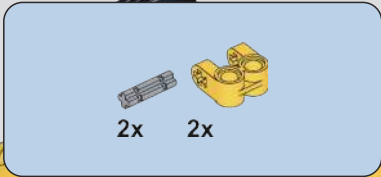

2x 2x

This inset box shows the parts required for step 4-22: two grey pins and two yellow Technic connectors. The text '2x' is placed below each part to indicate the quantity.

4-22

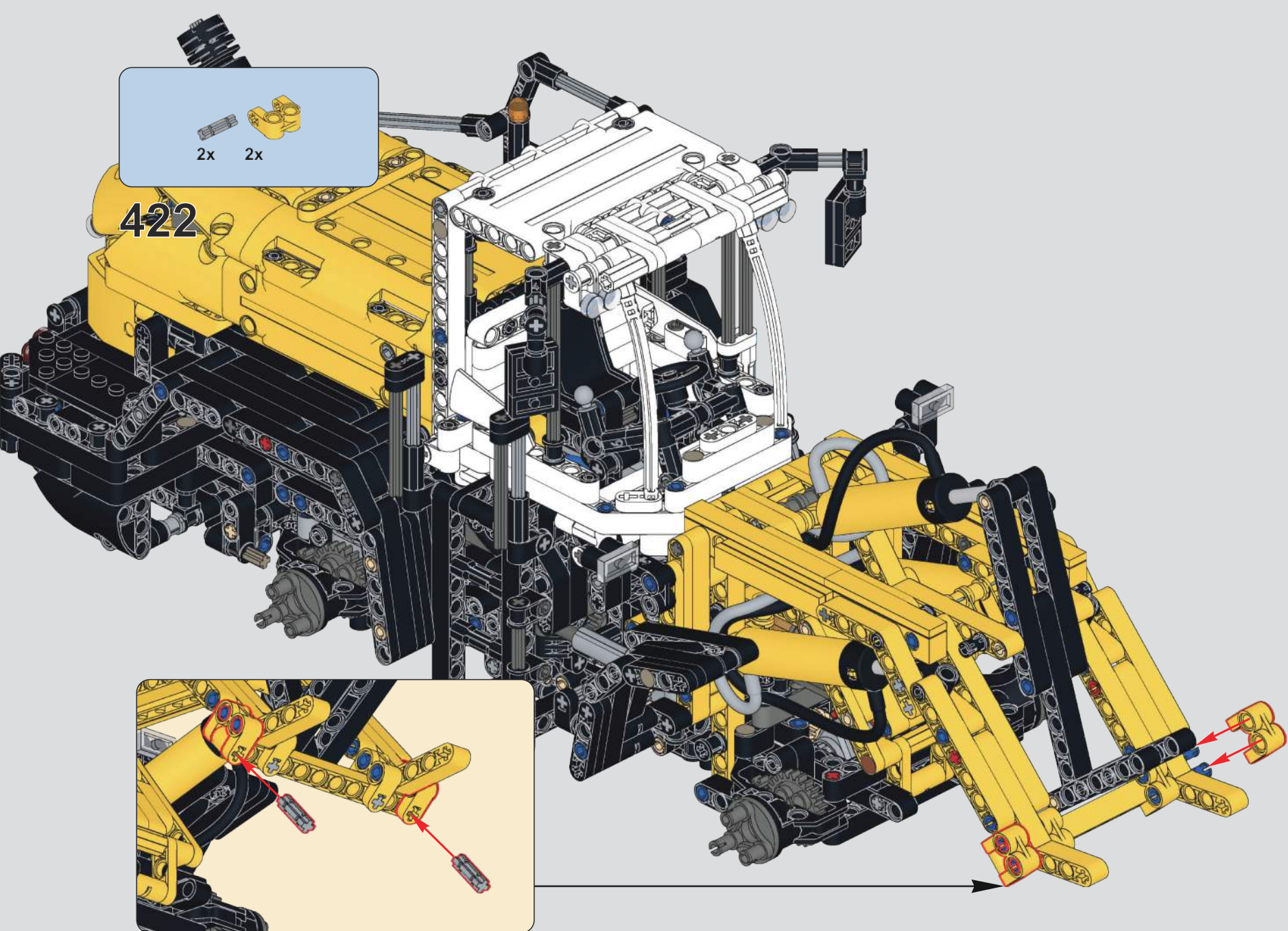

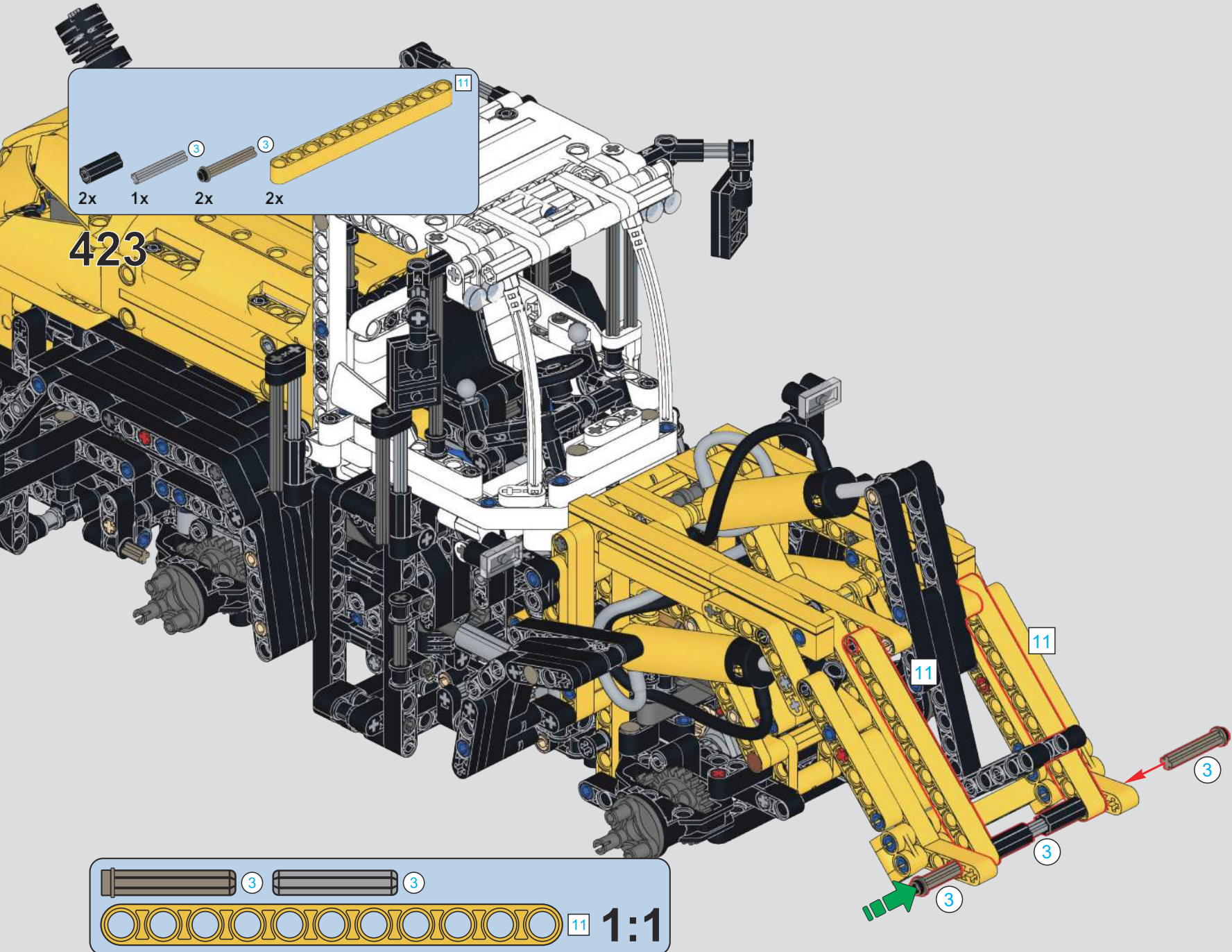

423

2x 1x 2x 2x 11

3 3 11 **1:1**



1x 2x 1x 2x 1x

4 5

1x

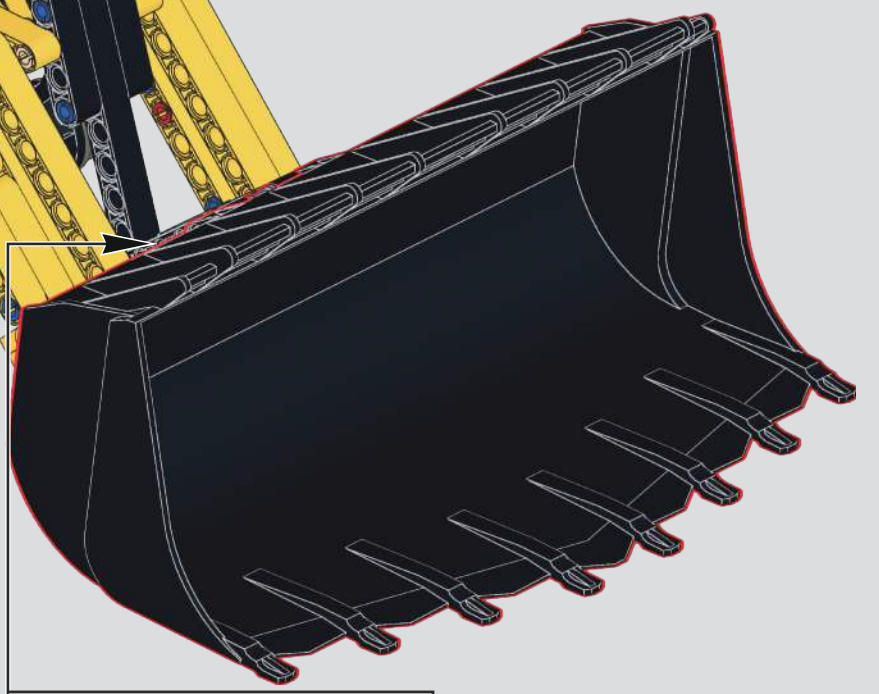

424

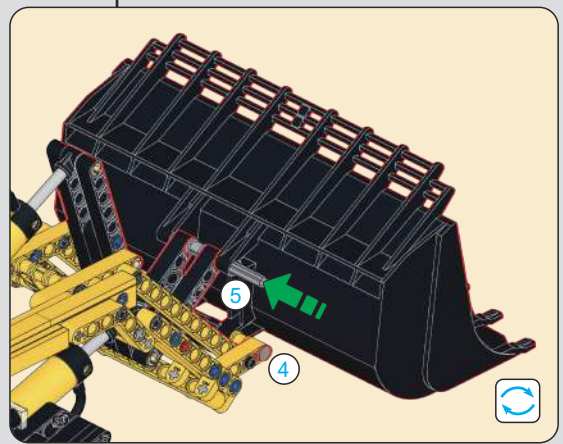
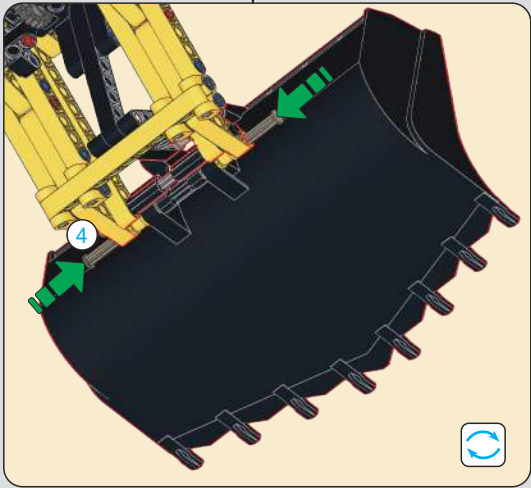

5 4 1:1



425

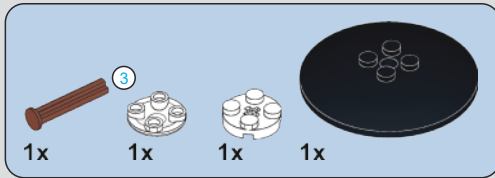

426

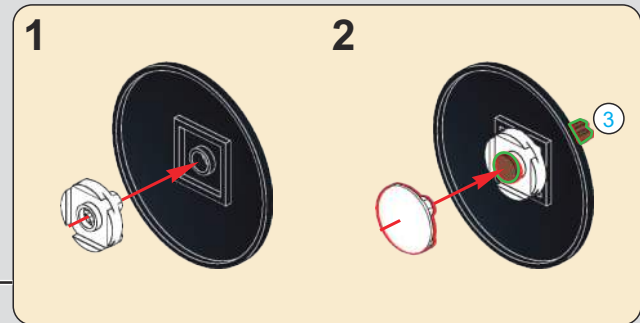
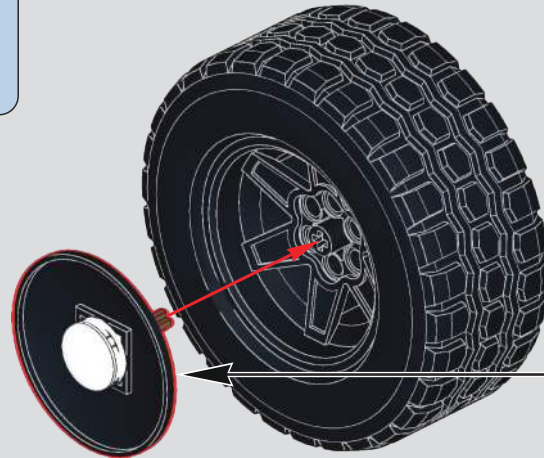

4x

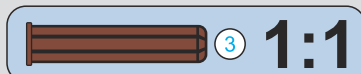

427

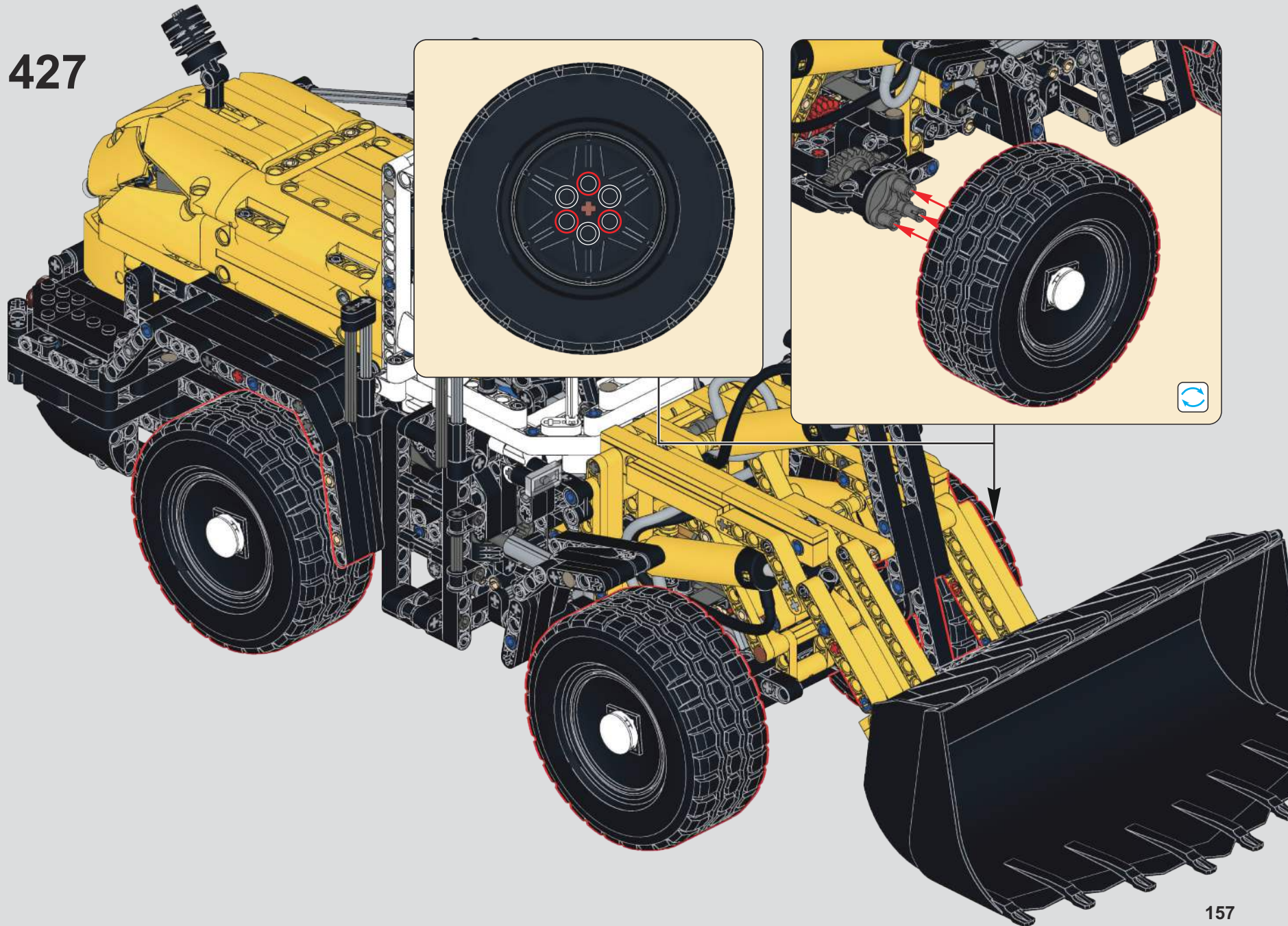



429

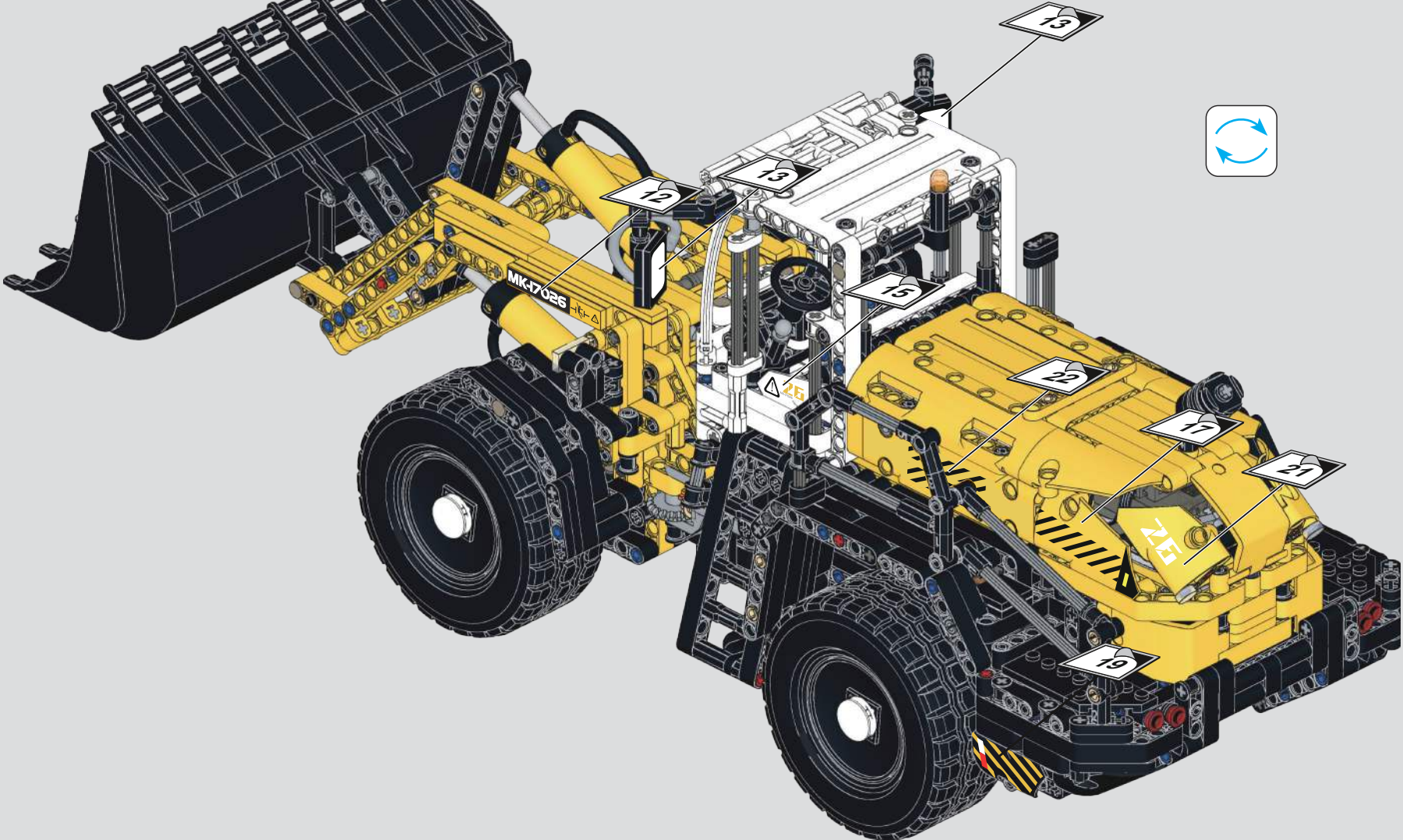

430



请扫描此二维码，获取并仔细查看6.0模块的操作说明书。
Please scan this QR code to obtain and carefully review the operation manual for the 6.0 module.

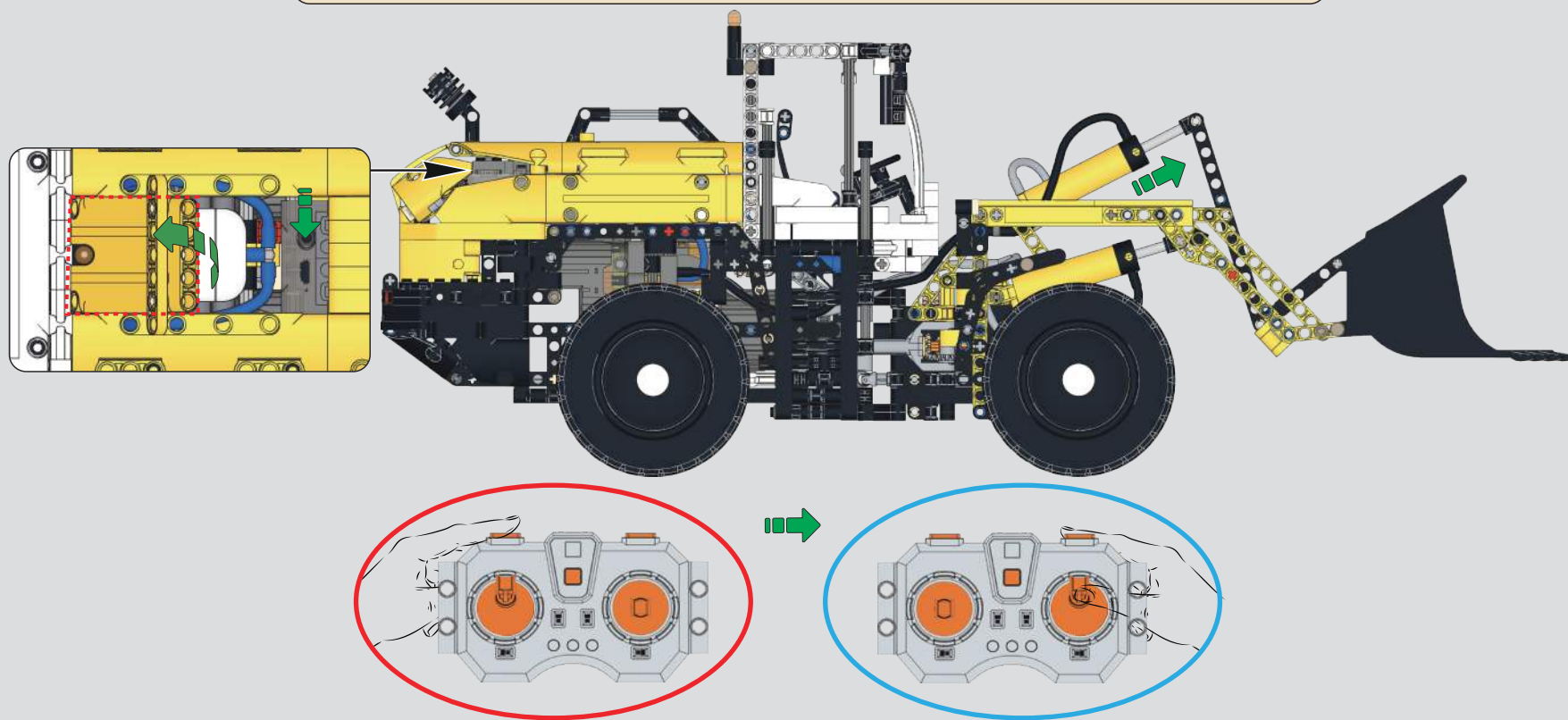

在此处打开模块并打开遥控器连接，长按遥控器左前端上下任意按键（E键）进行打气，再将遥控器右摇杆↑↓移动（C通道），控制铲斗小臂抬升下降，如若无法操作则需继续打气。

Open the module here and connect the remote control. press and hold any up or down button on the front left side of the remote control (E key) to inflate, then move the right joystick up or down (C channel) to control the raising and lowering of the excavator's small arm. If it cannot be operated, continue to inflate.

431

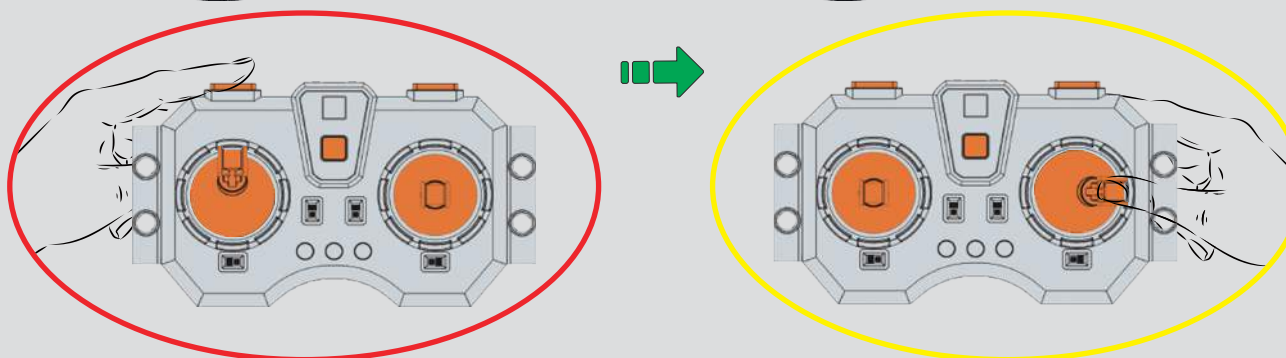
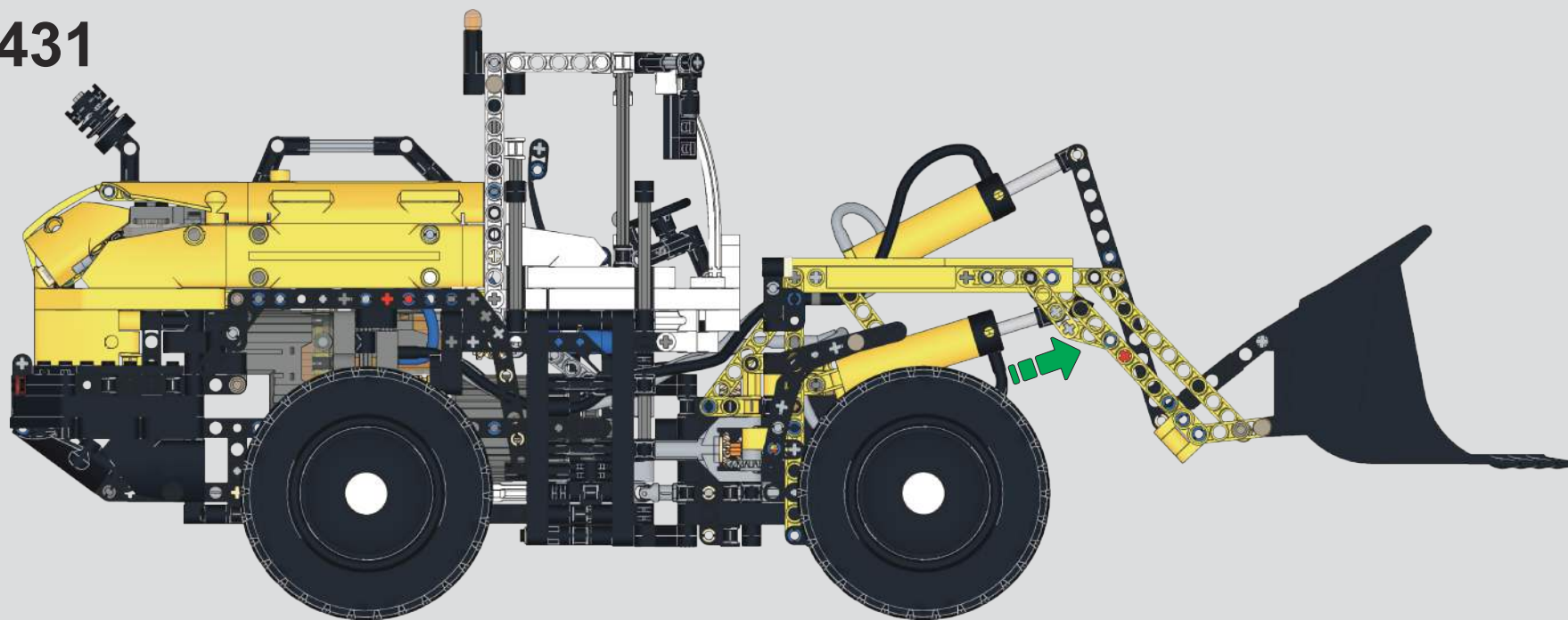

长按遥控器左前端上下任意按键（E键）进行打气，再将遥控器右摇杆←→移动（D通道），控制铲斗大臂抬升下降，如若无法操作则需继续打气。

Press and hold any up or down button on the front left side of the remote control (E key) to inflate, then move the right joystick left or right (D channel) to control the raising and lowering of the excavator's large arm. If it cannot be operated, continue to inflate.

432

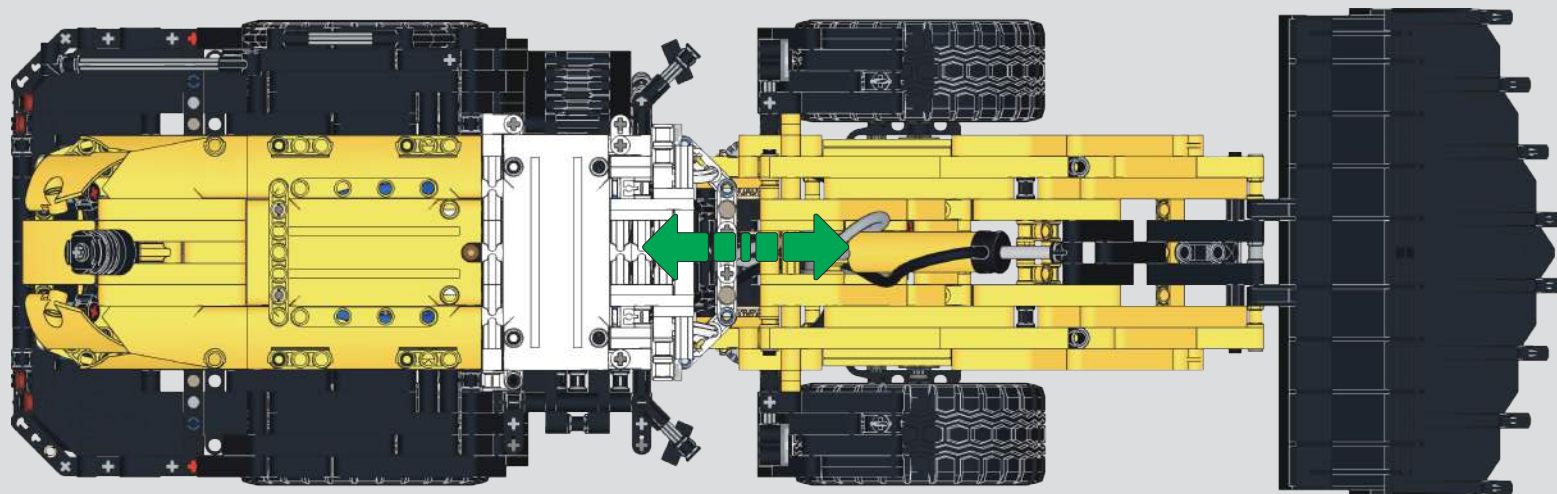

将遥控器左摇杆↑↓移动（A通道），控制车辆前进后退。
Move the left joystick up or down (A channel) to control the vehicle's forward and backward movement.

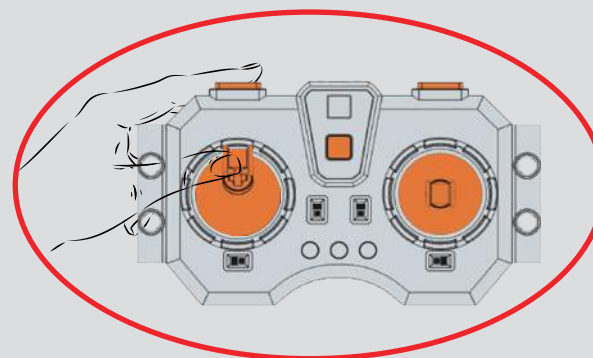

433

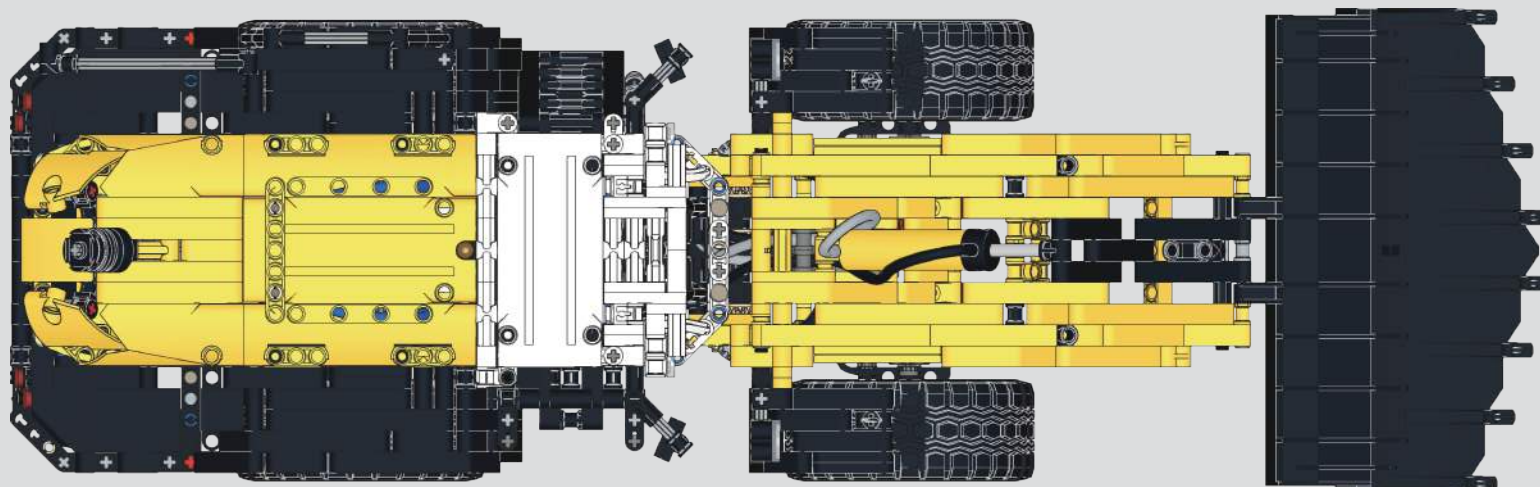

将遥控器左摇杆←→移动（B通道），控制车辆左右转向。
Move the left joystick left or right (B channel) to control the vehicle's left and right steering.

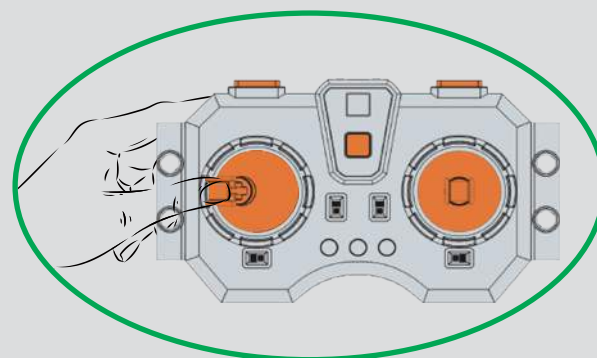

**MULD
KING**

®

宇 | 星 | 模 | 王

