

**MULD
KING**

宇 | 皇 | 模 | 王

17058

997+ Pcs/Pza

®

宇皇工程系列

MODELS  **NO. MECHANICAL CRANE**

机械吊车





Qr code APP (APP二维码)

Need the apple version 9.0 and above, the android version 5.0 and above.

* This APP supports most of the mainstream Android models on the market, but due to the large number of Android models, different models of systems and hardware reasons, there may be some models do not support, specific according to the actual test!



广东宇星科技
Mould King



产品资讯
Product Information



售后服务
After-sales Service



积木补件
Brick Replacement Service

Customer Service
客户服务



www.yx-mk.com



"酷砖家"是宇星魔王设立的特殊标识，代表着产品的独特性和原创性。每一款带有"酷砖家"标志的积木套装，都由宇星的原创团队或者与宇星有密切合作的全球顶尖设计师亲自设计或授权。这个标识是我们对消费者的承诺，确保他们可以享受到独一无二且高品质的积木拼搭体验。

"Bri X pert" is a special mark established by MOULD KING, representing the uniqueness and originality of the product. Every building set with the "Bri X pert" logo is personally designed or authorized by MOULD KING's innovative team or world-class designers who work closely with MOULD KING. This logo is our commitment to consumers, ensuring that they can enjoy a unique and high-quality building experience.

OPEN

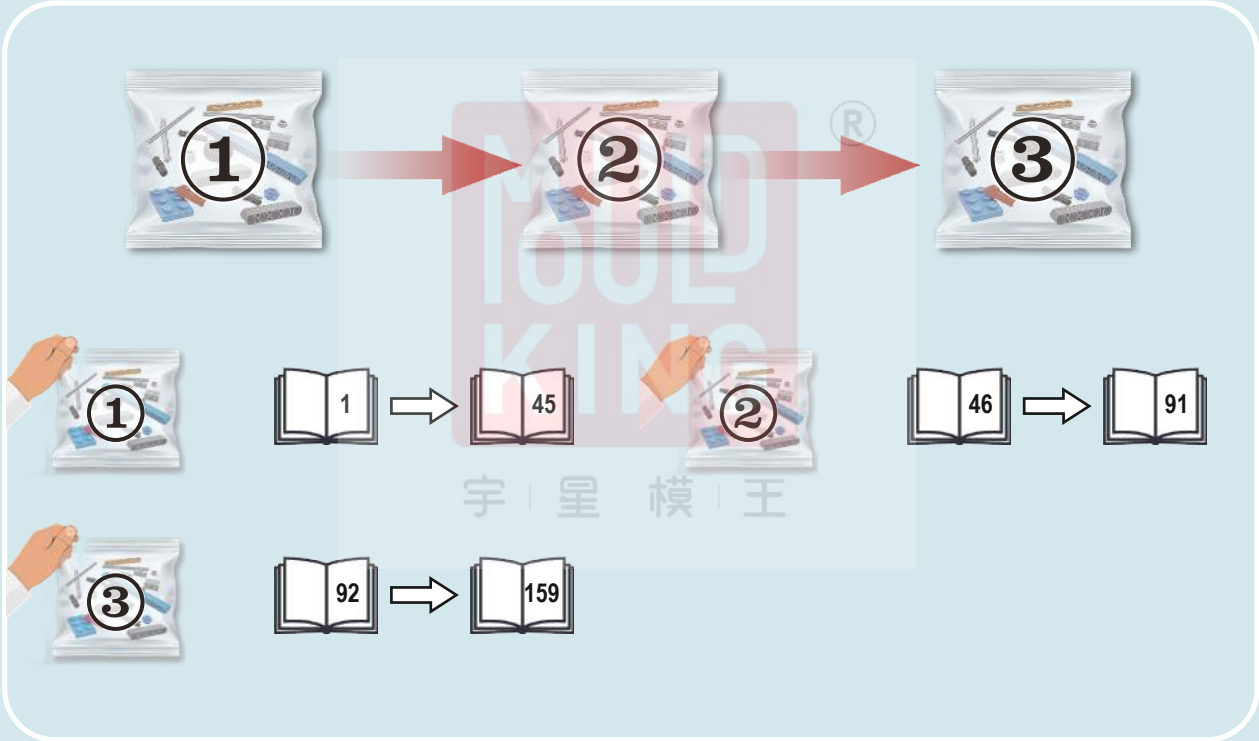

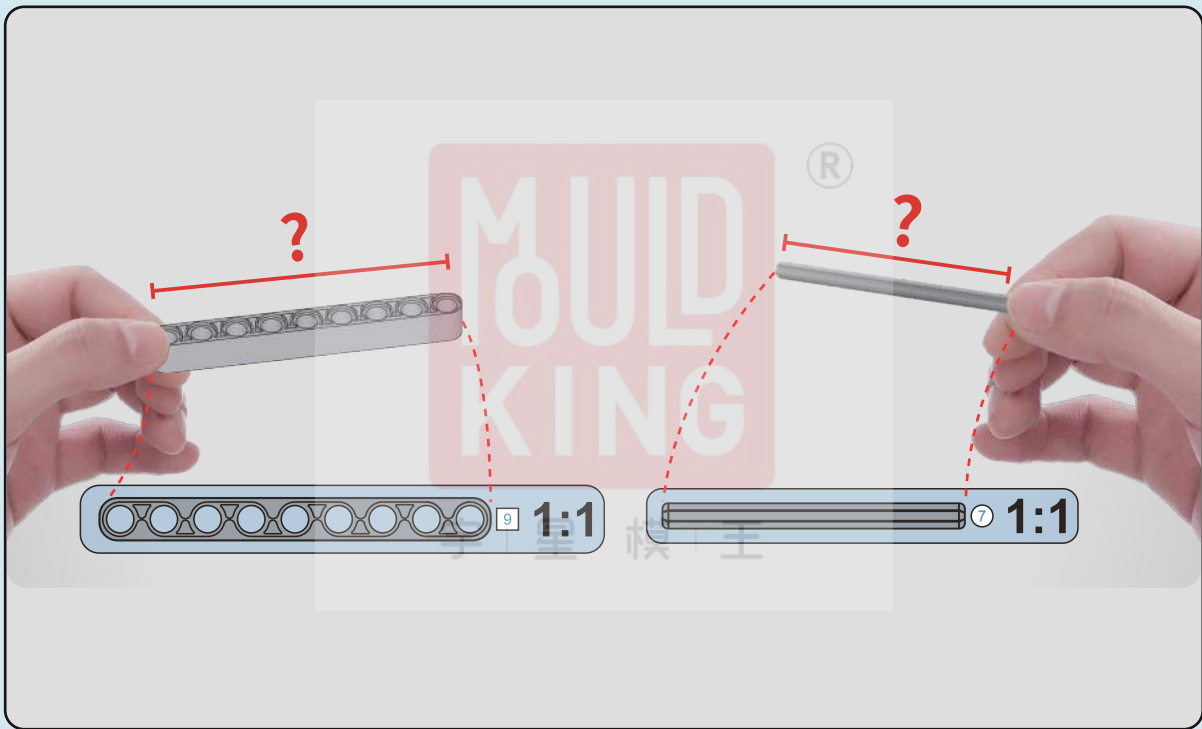

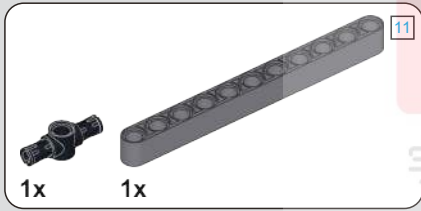
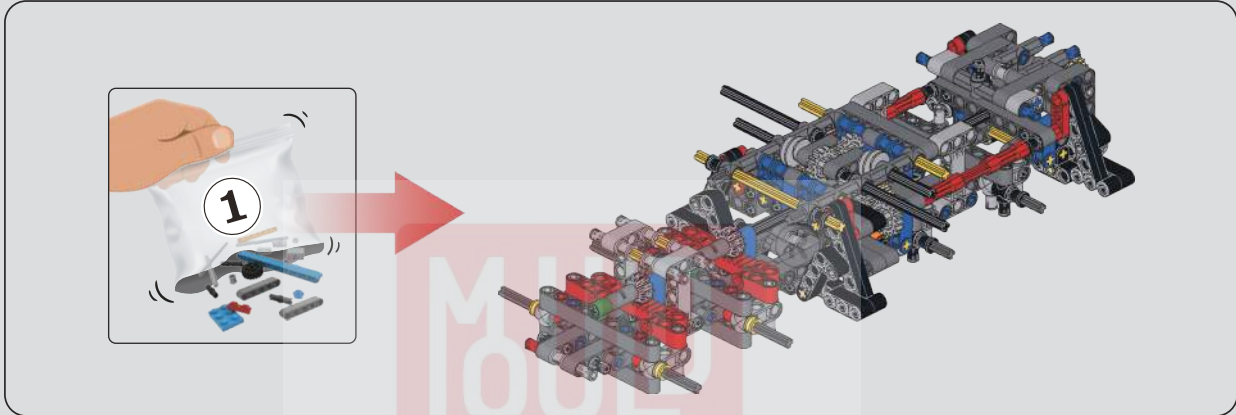

1

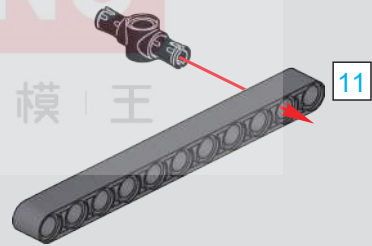

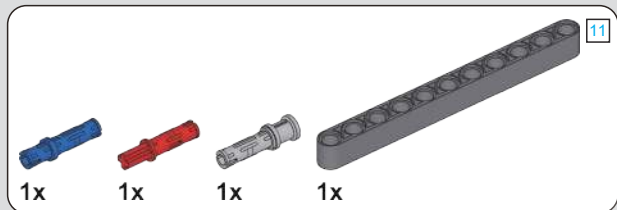

2

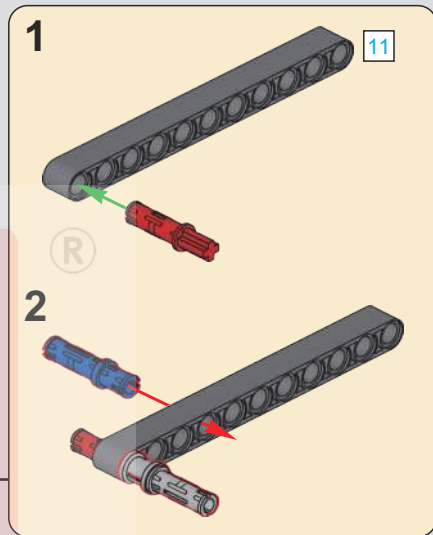
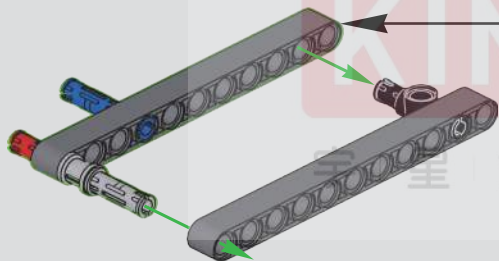

2



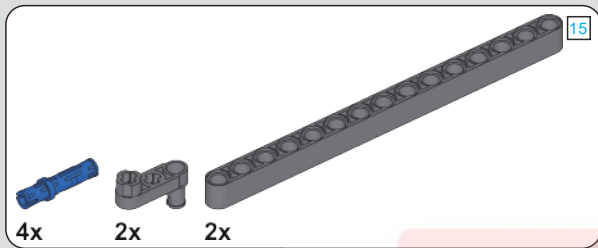

3

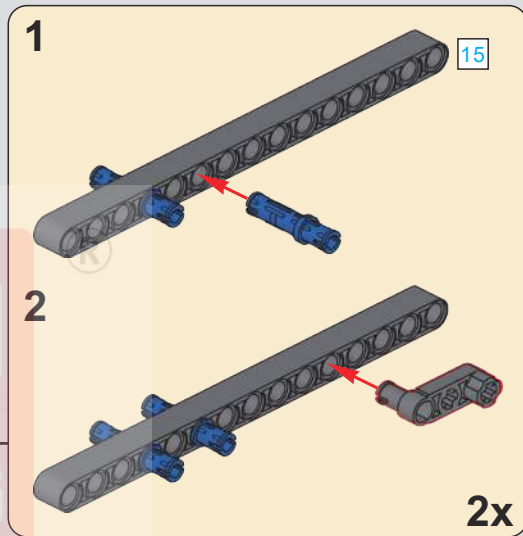
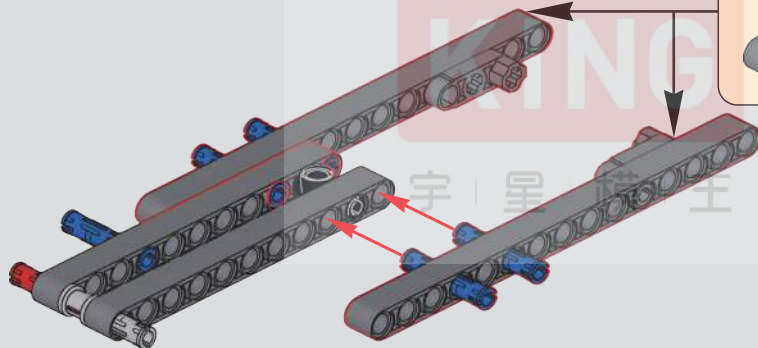

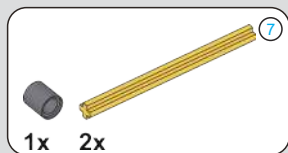

4

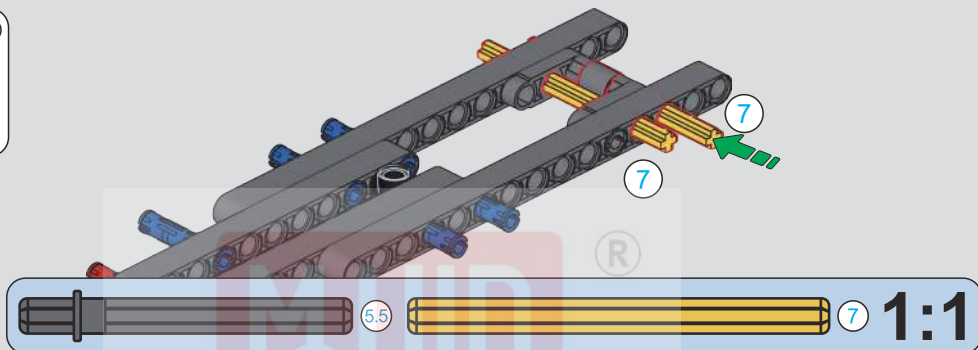

5

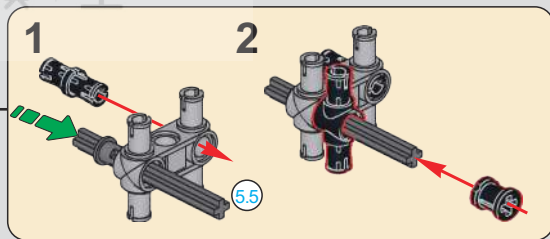
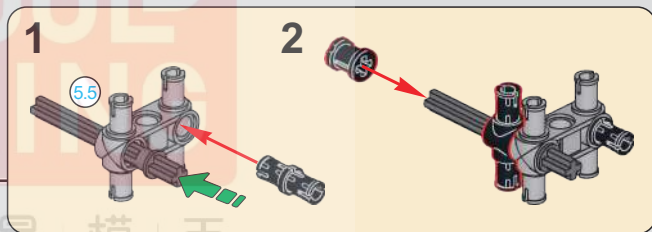
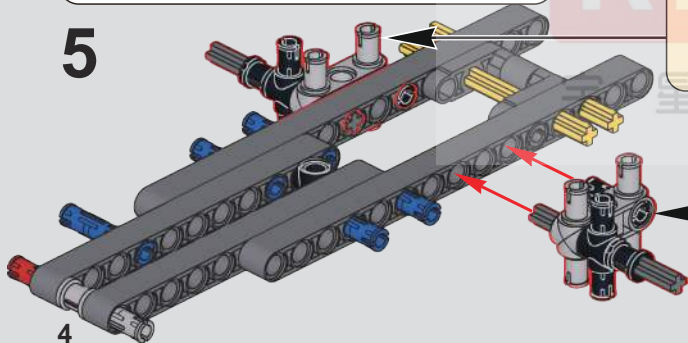

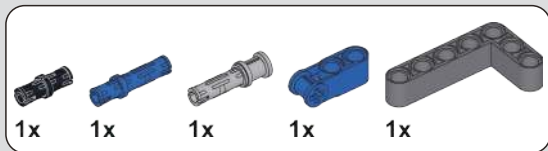

6

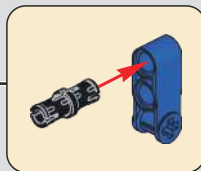
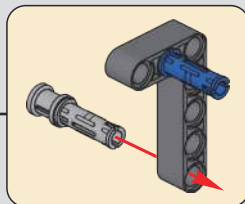
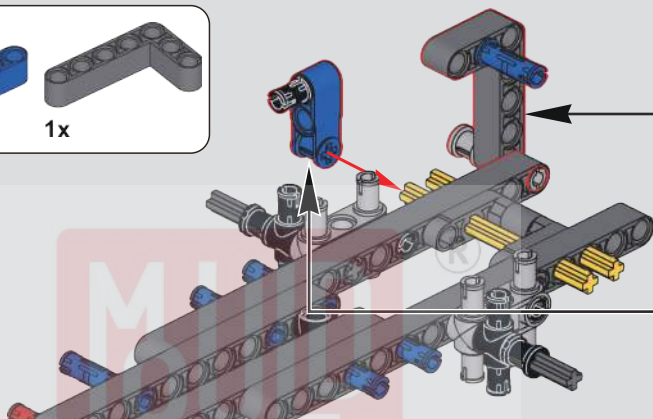

7

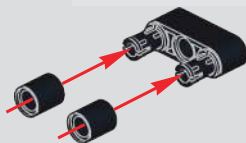

8

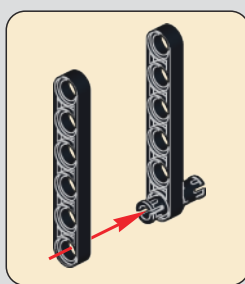
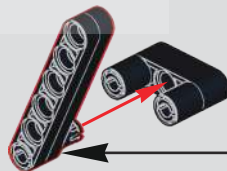

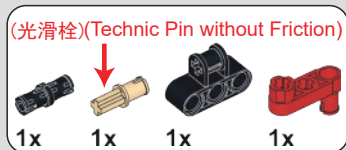
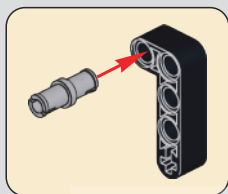

10

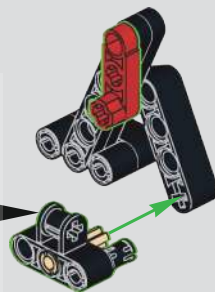
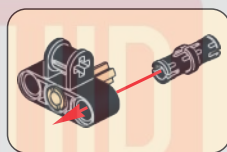

9



11

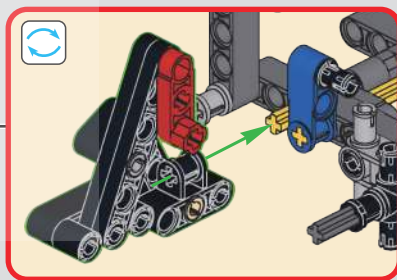
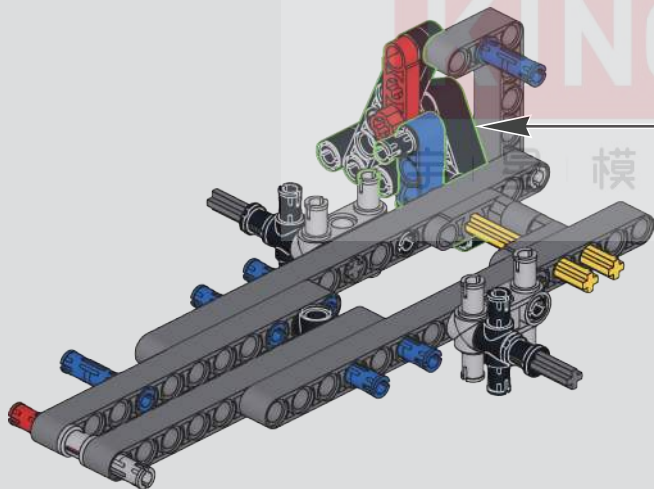

6

模 | 王

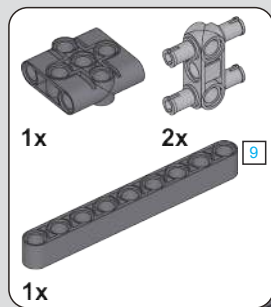

12

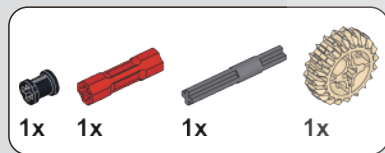
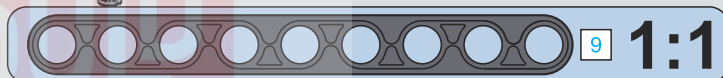
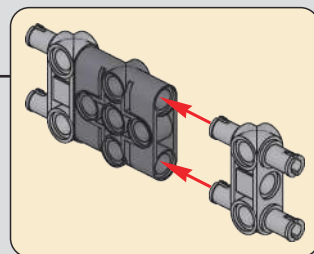
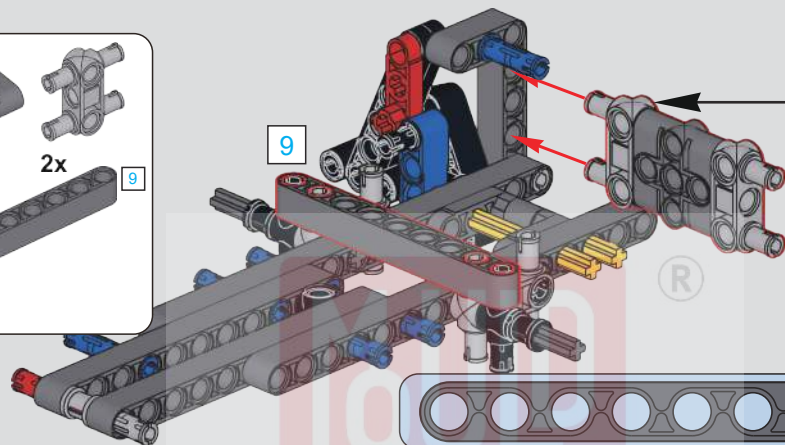

13

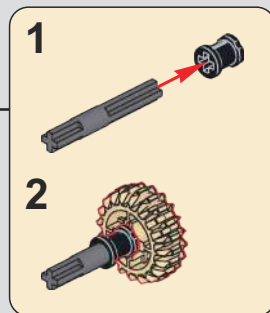
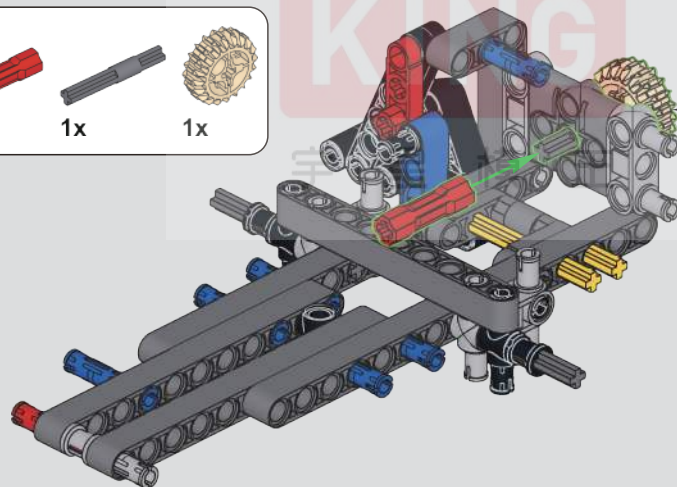

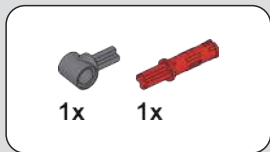
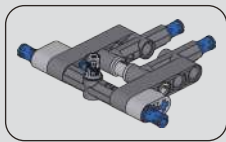

14

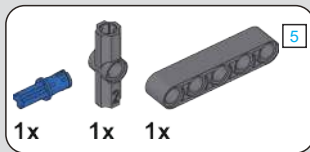
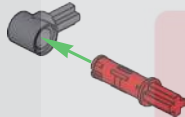

15

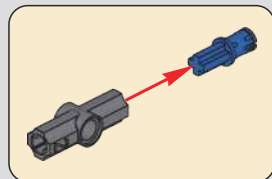
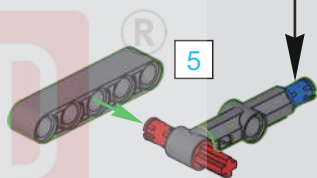

5

1:1

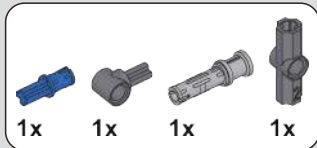

16

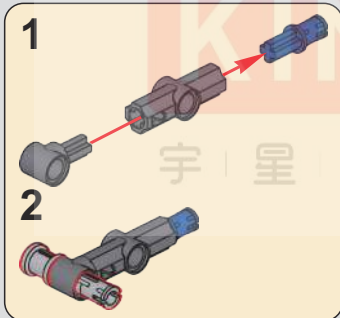
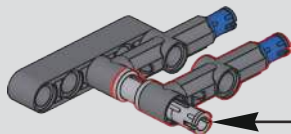

17

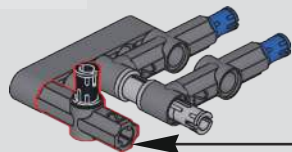
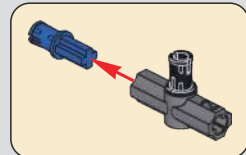

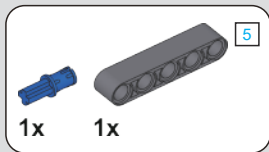

18

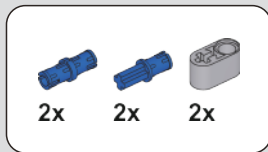
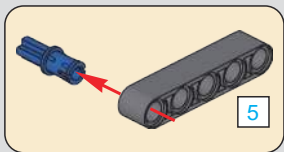
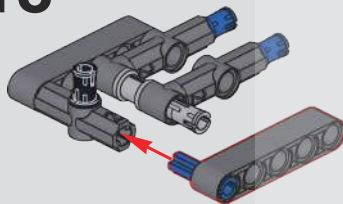

19

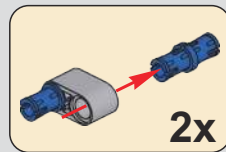
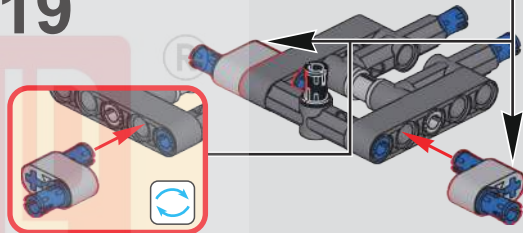

20

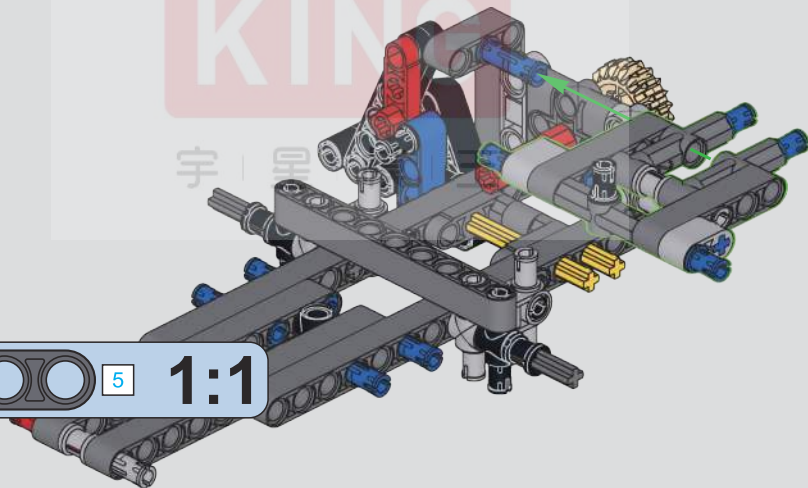

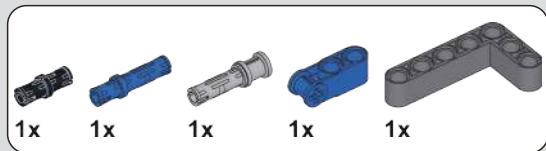

21

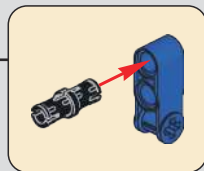
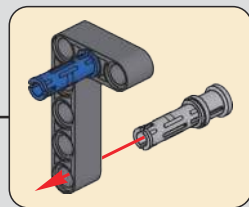
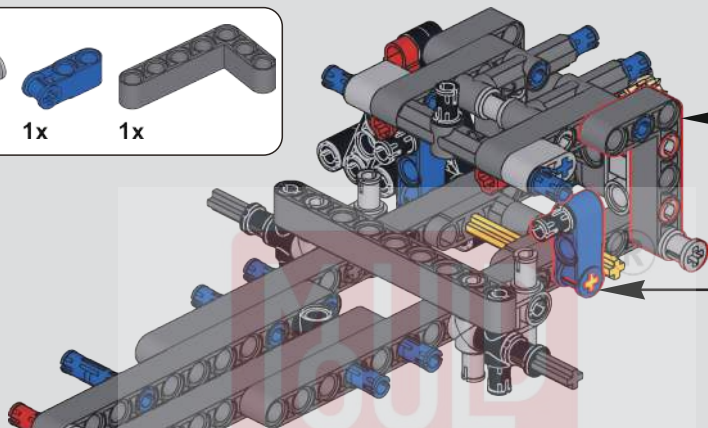

22

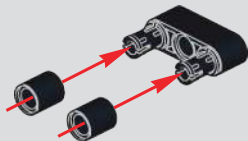

23

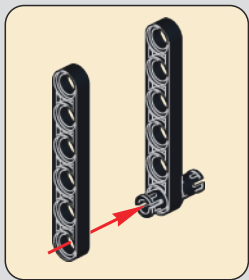
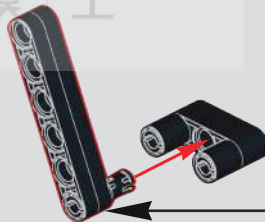

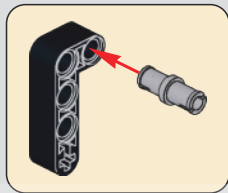
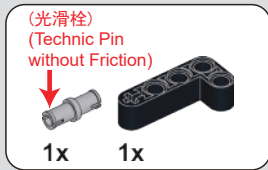

24

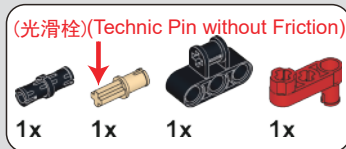
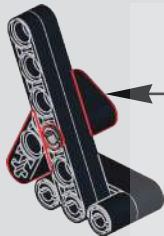

25

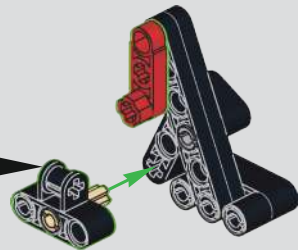
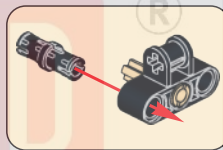

26

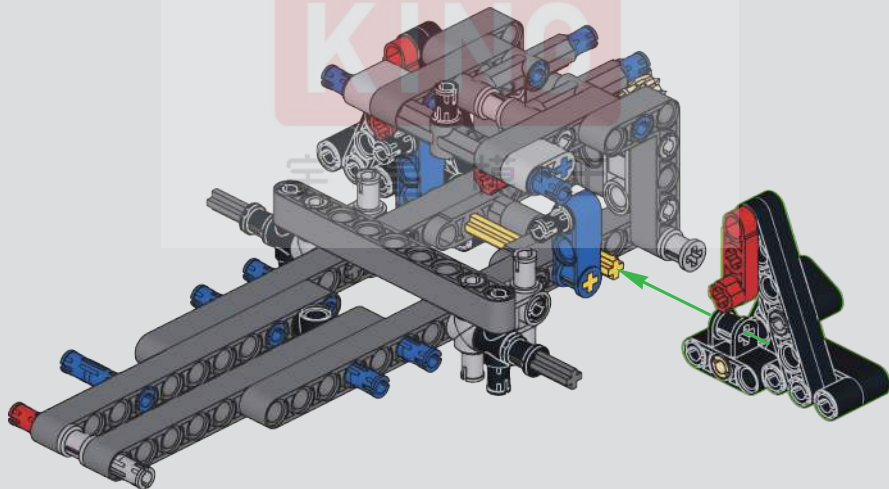

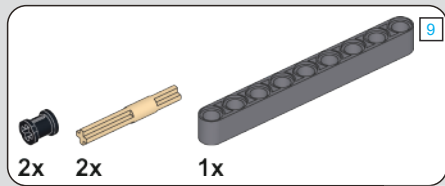

27

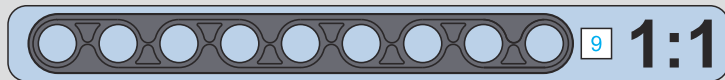
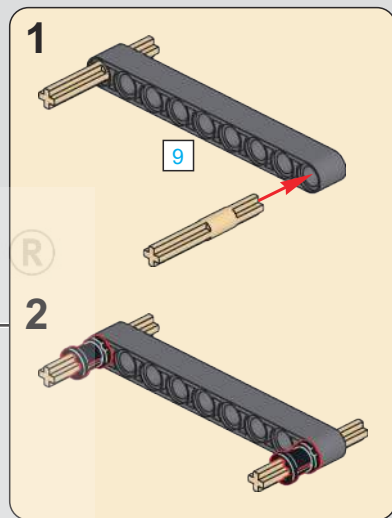
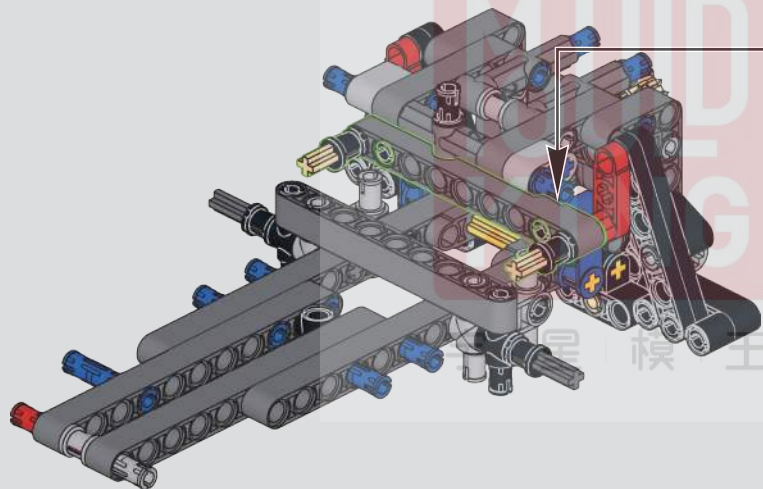



28

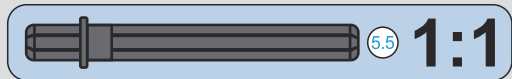
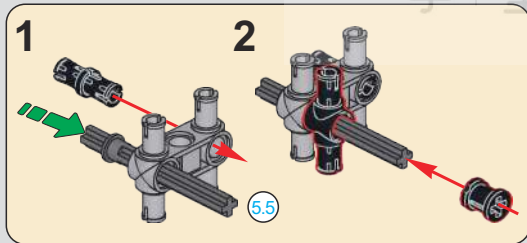
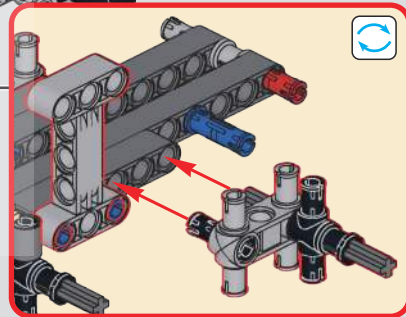
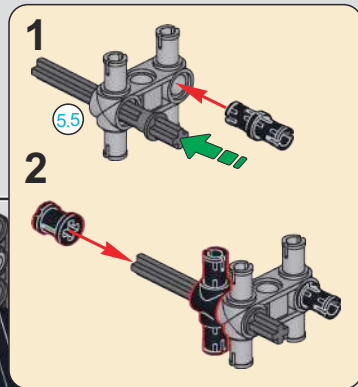
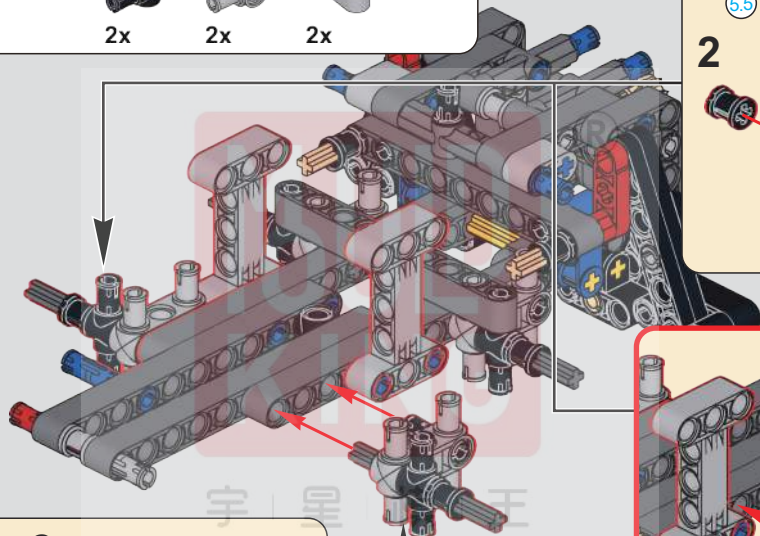

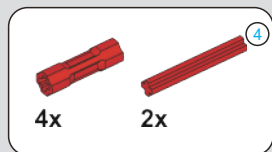

29

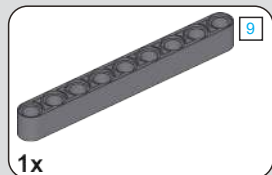
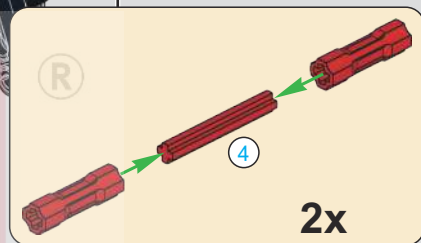
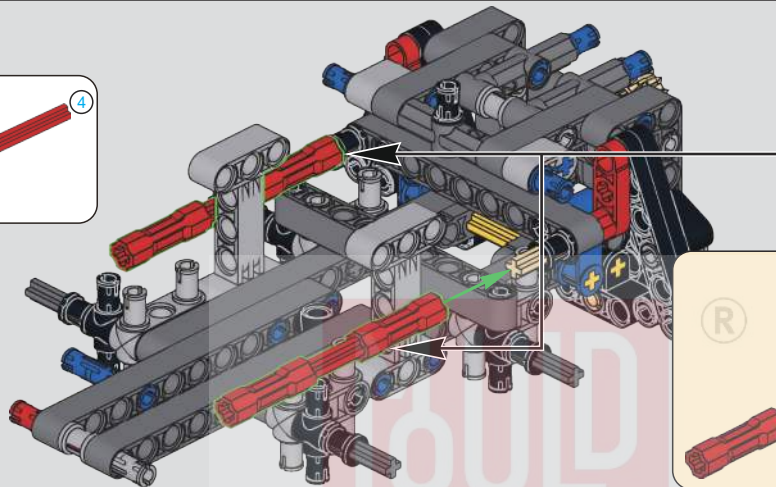

30

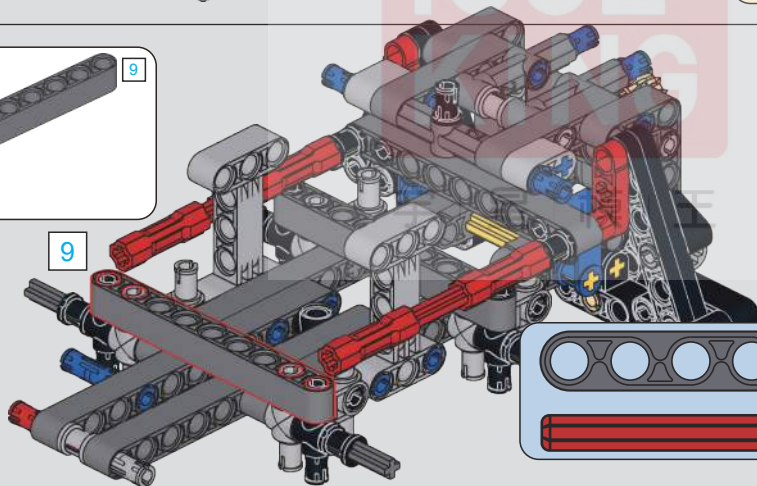

14

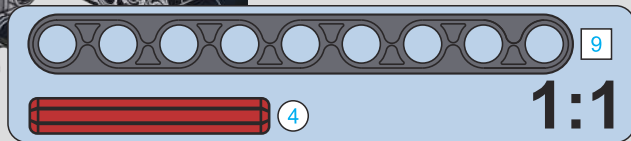



31

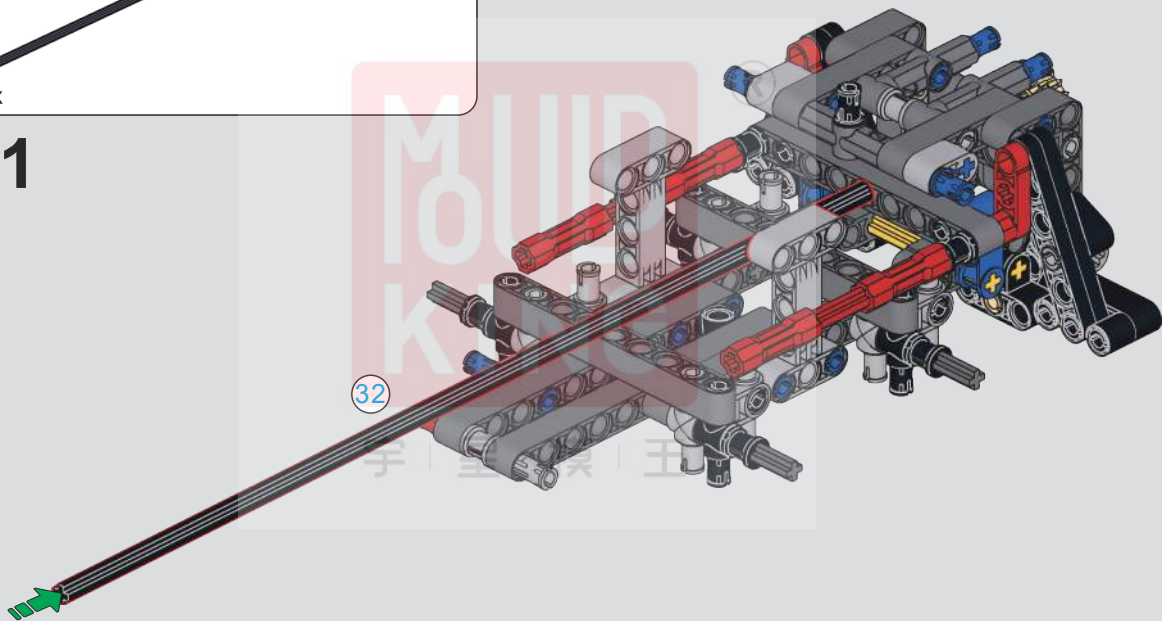

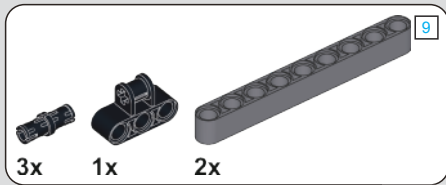

32

9

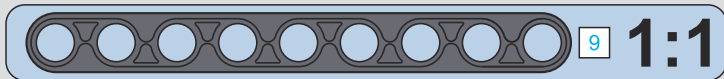
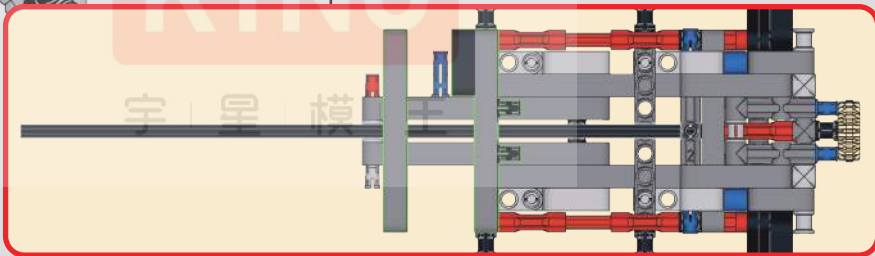
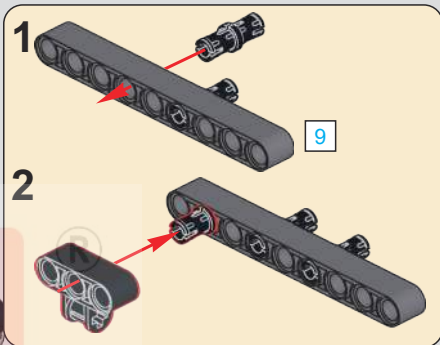
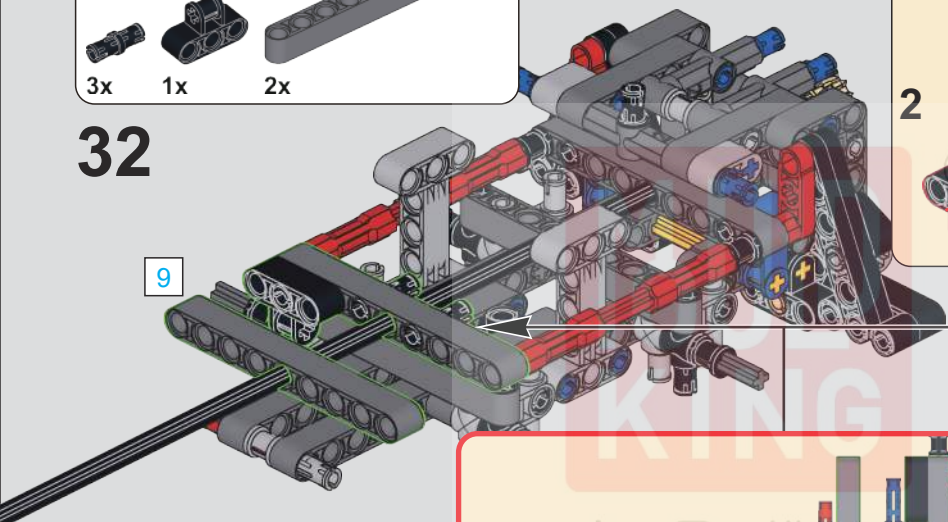

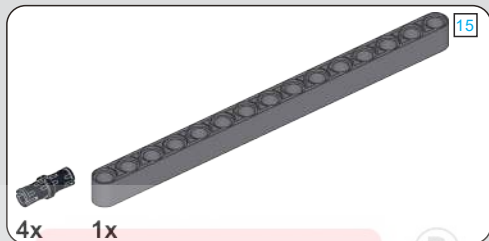
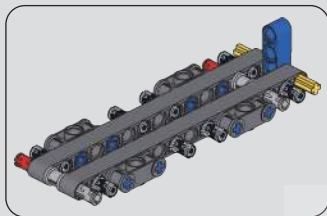

33

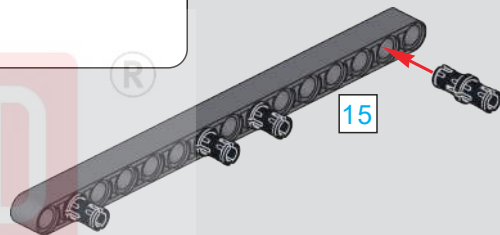

34

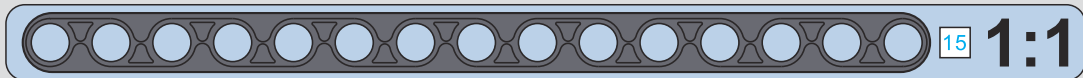
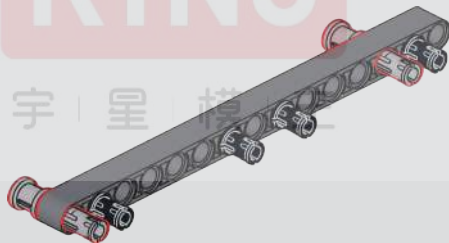

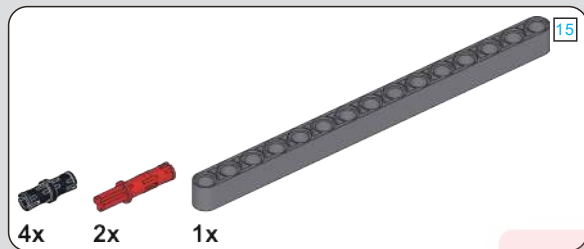

35

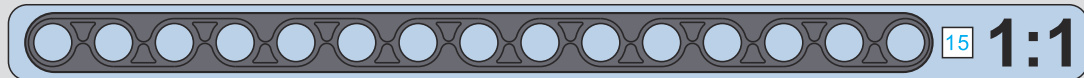
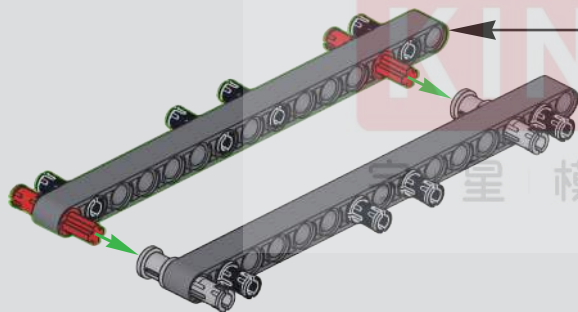
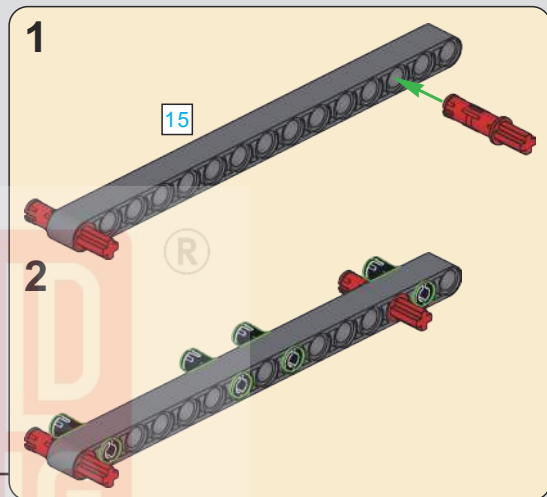

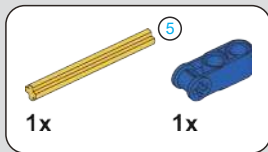

36

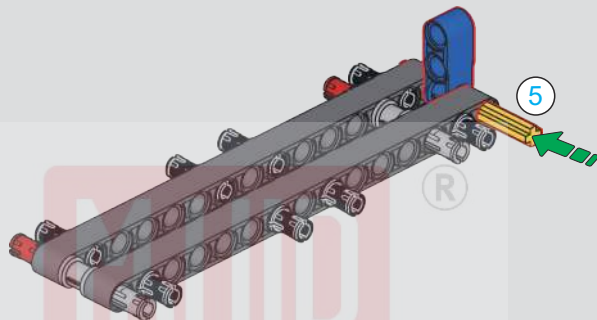

37

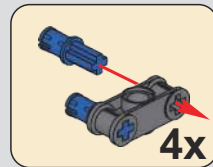
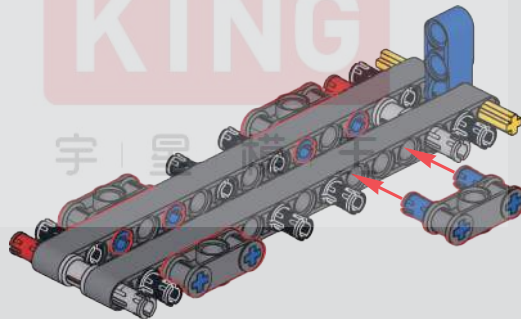

38

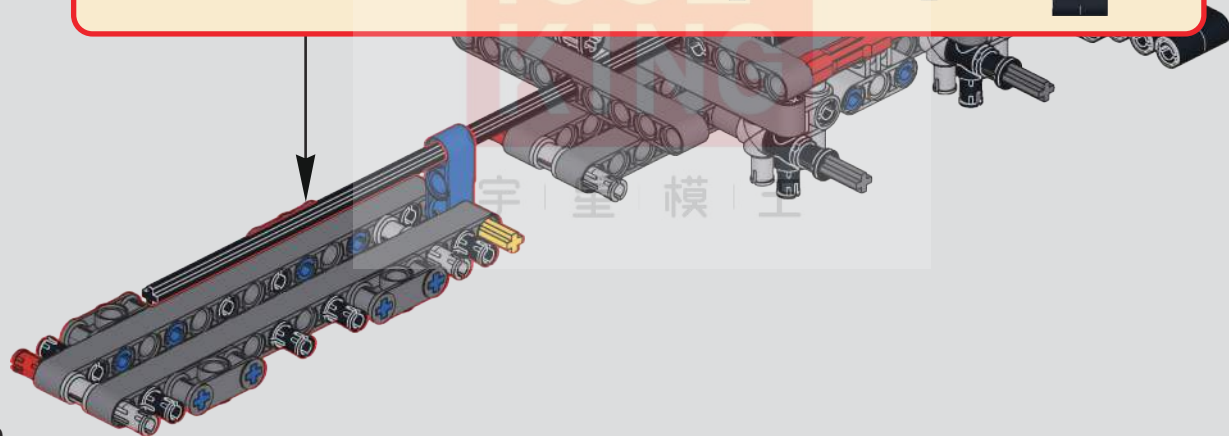
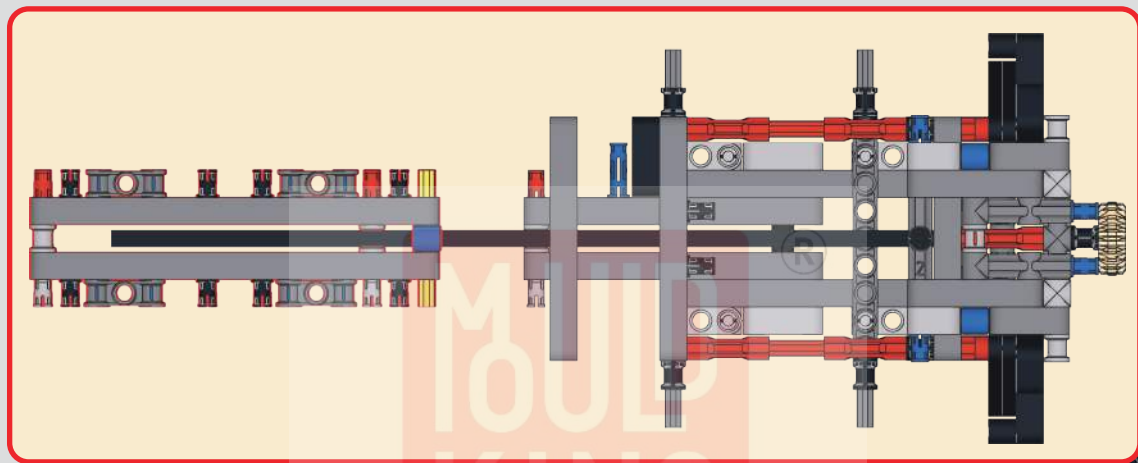

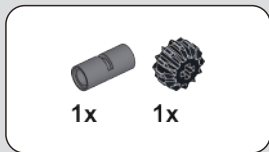

39

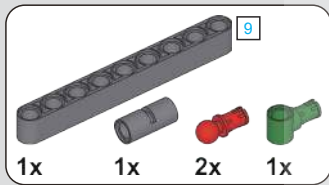
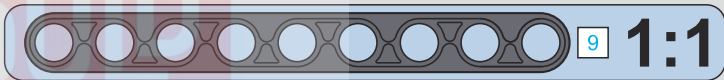
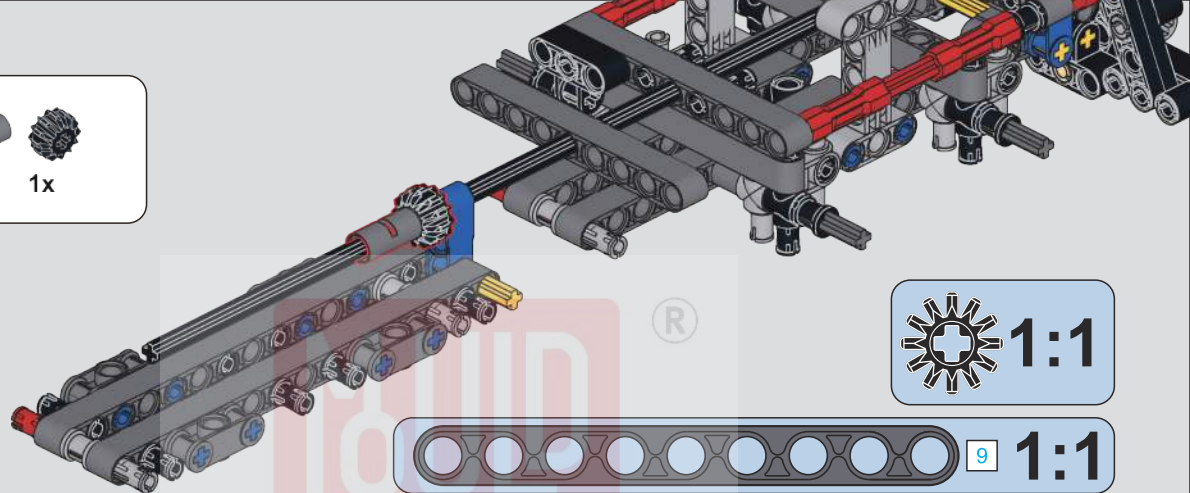

40

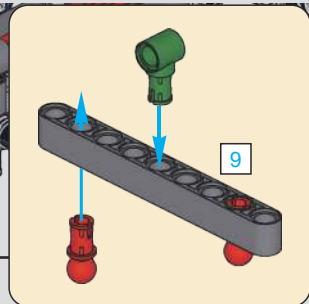
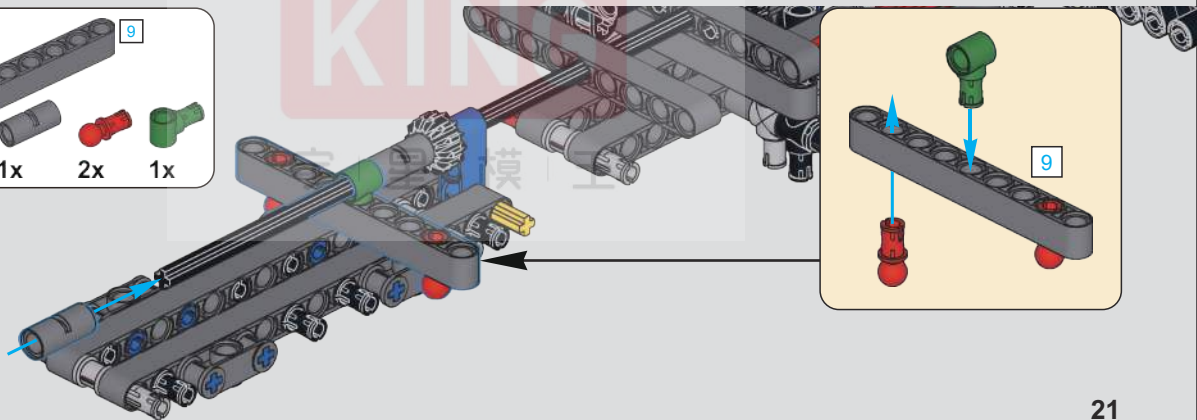

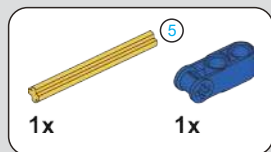

41

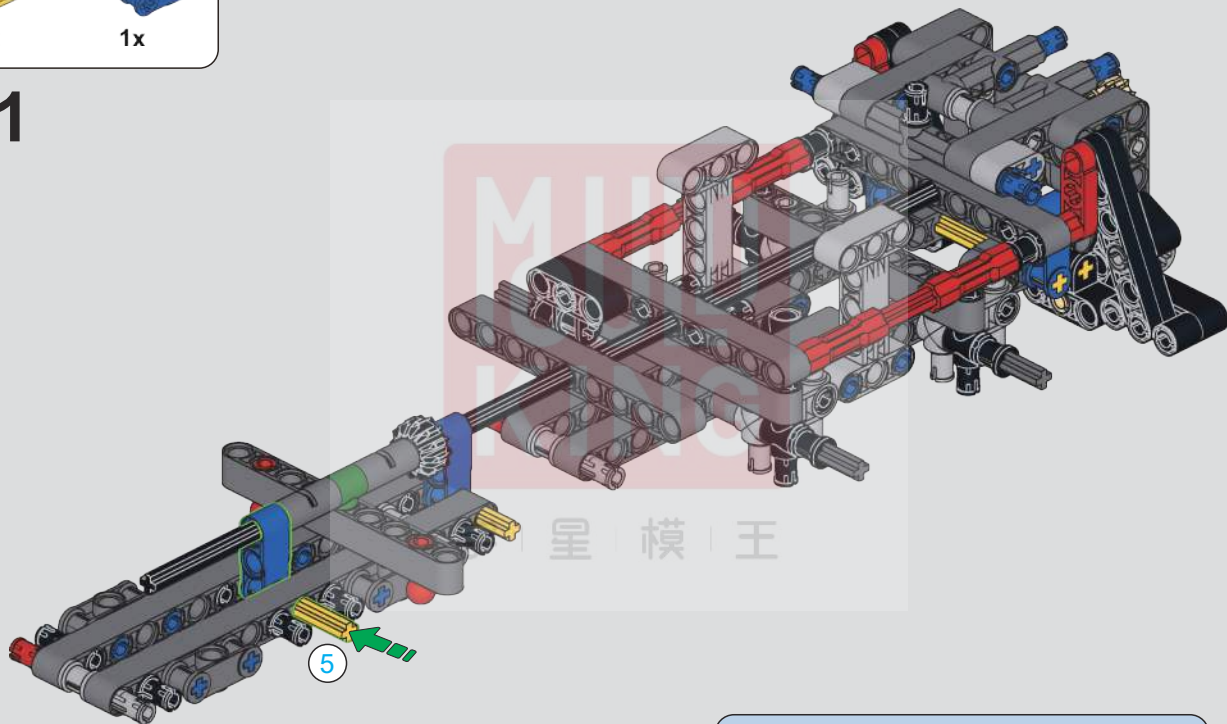

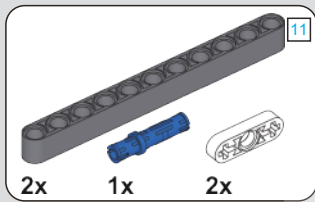

42

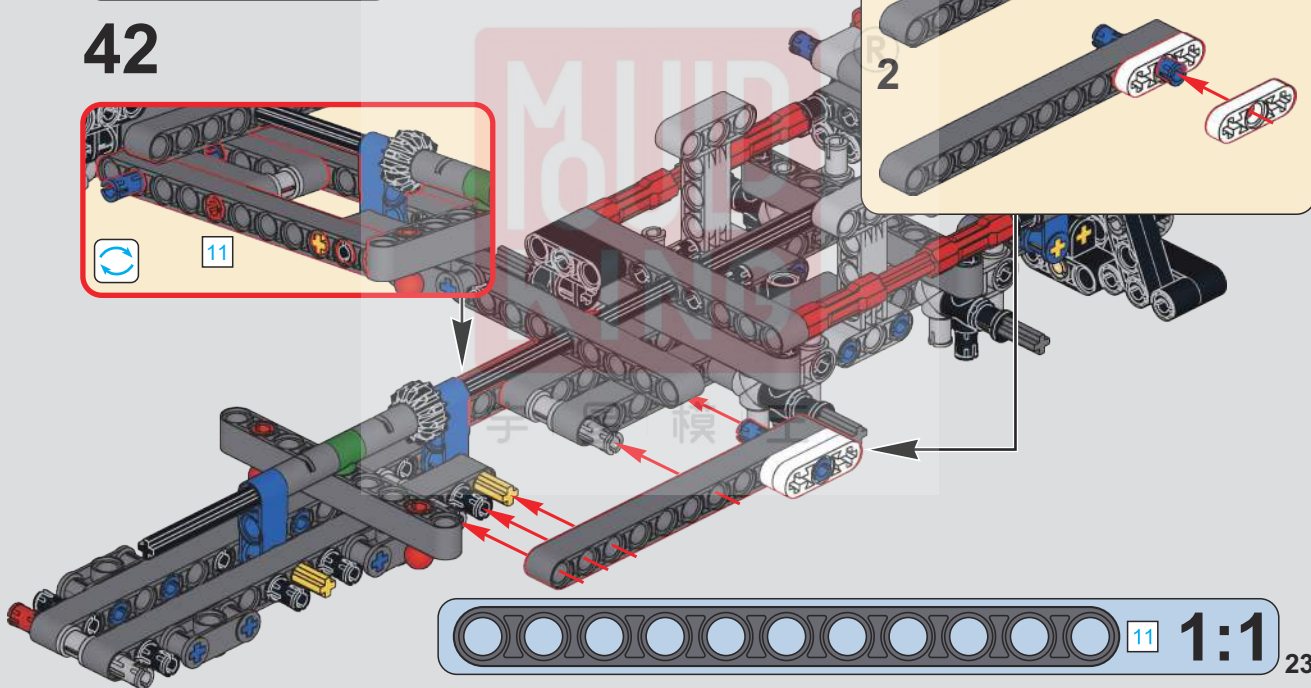
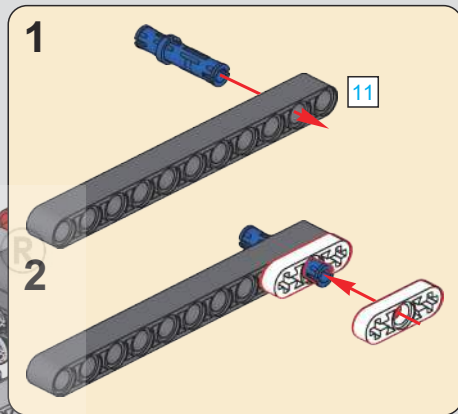
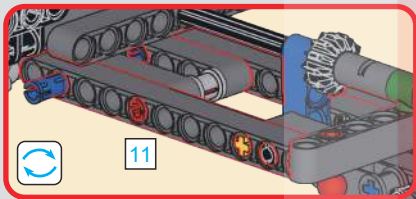

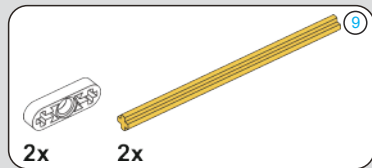

43

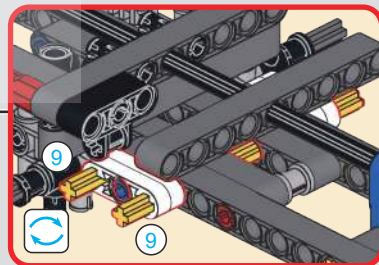
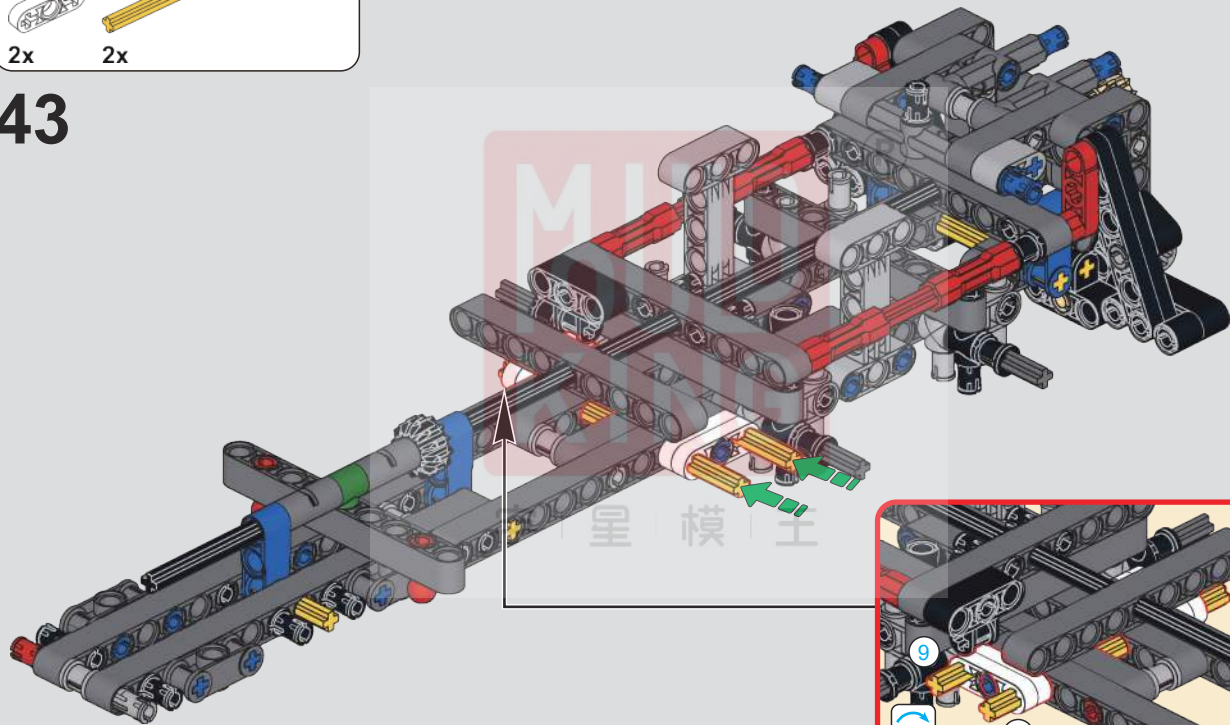

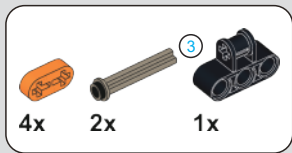

44

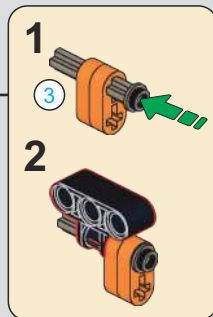
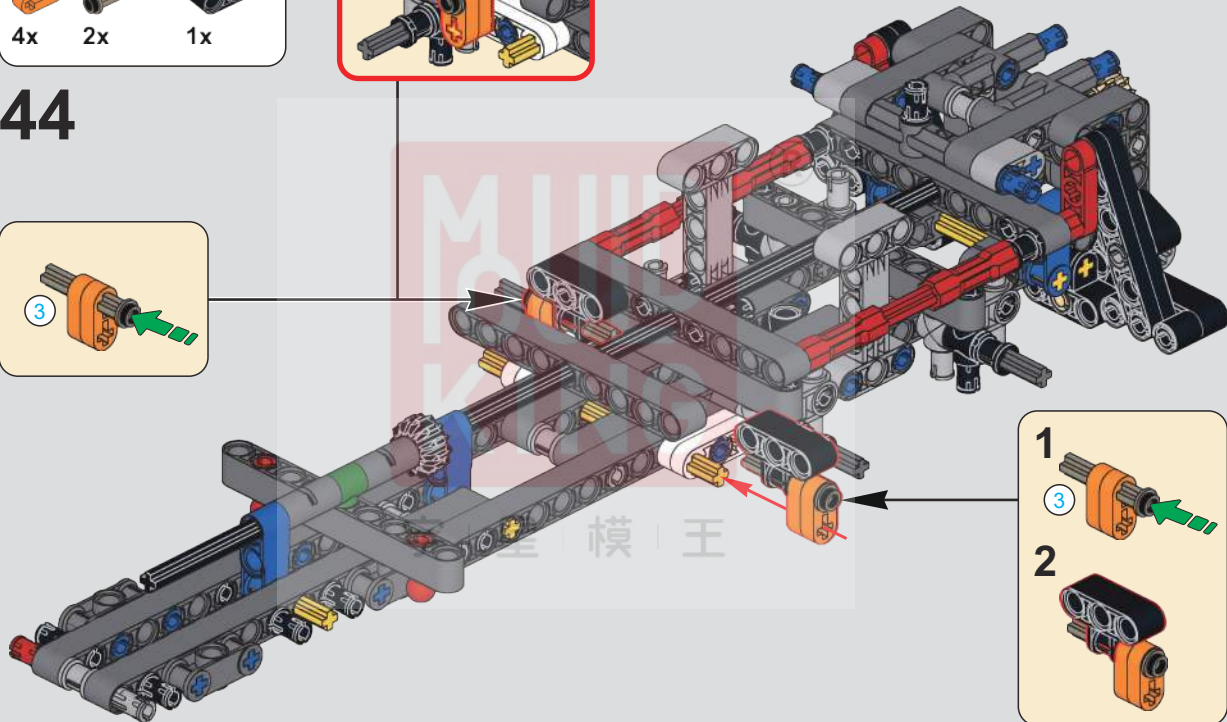
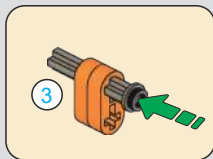
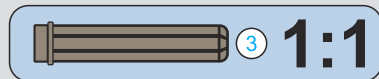
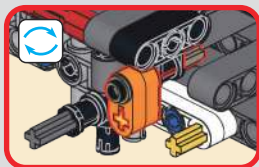



2x

45

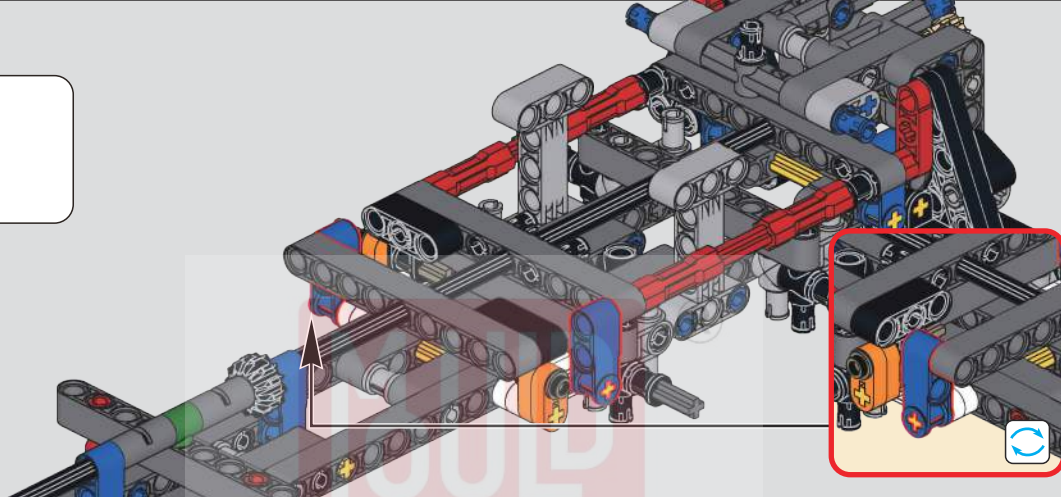

2x

46

26

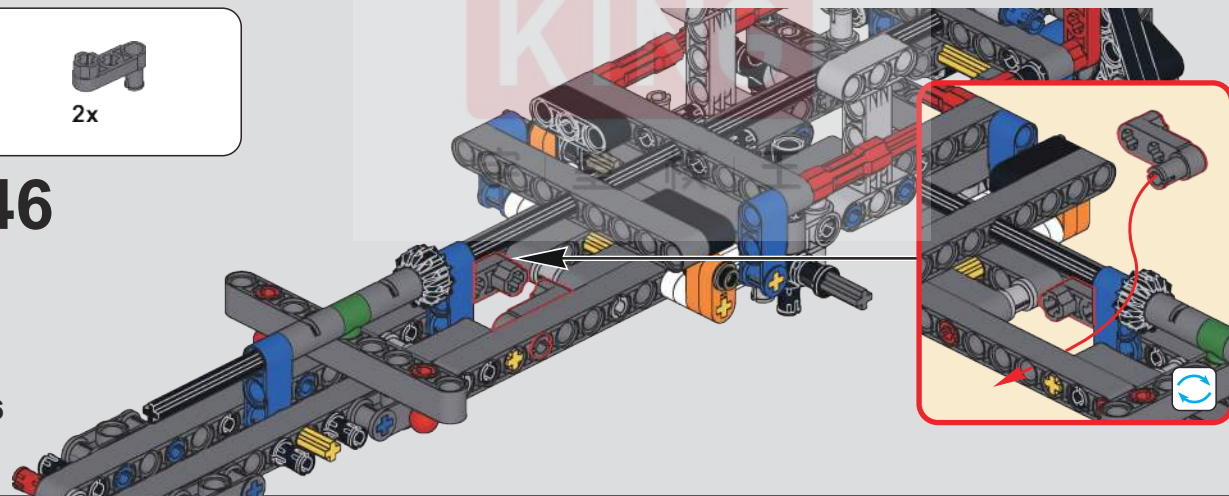

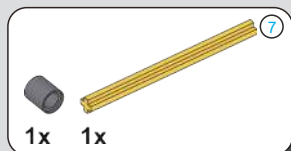

47

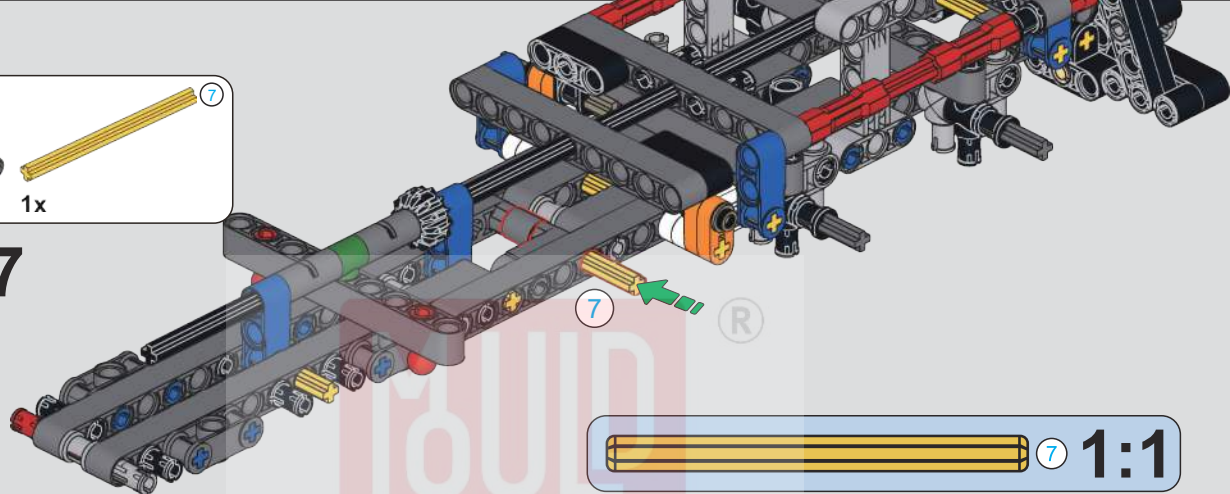

48

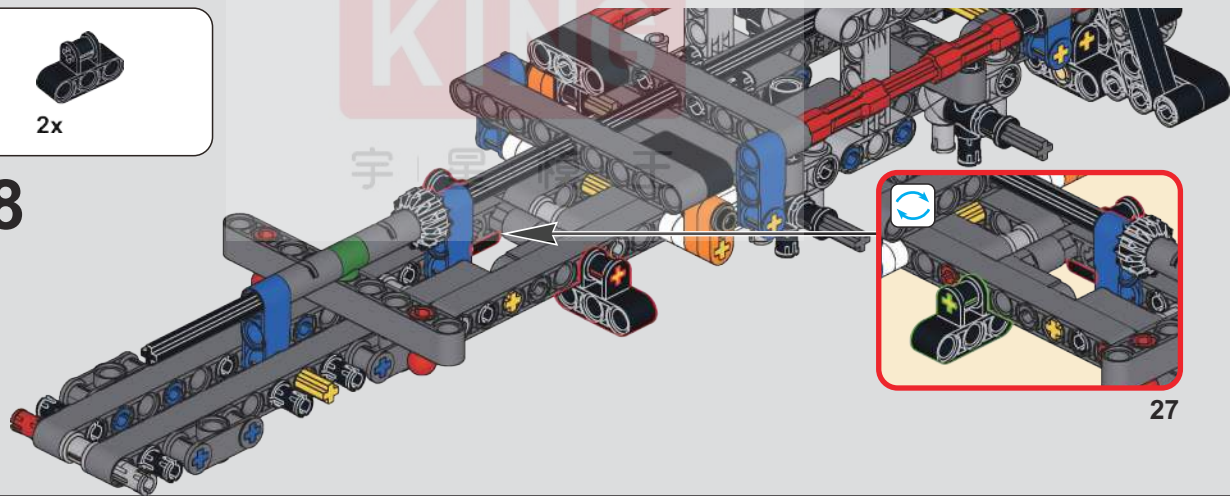

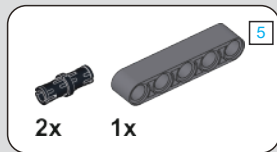

49

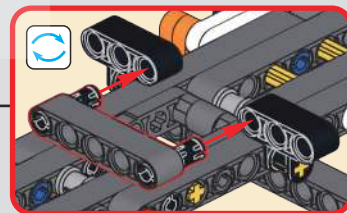
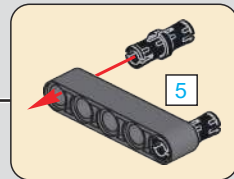
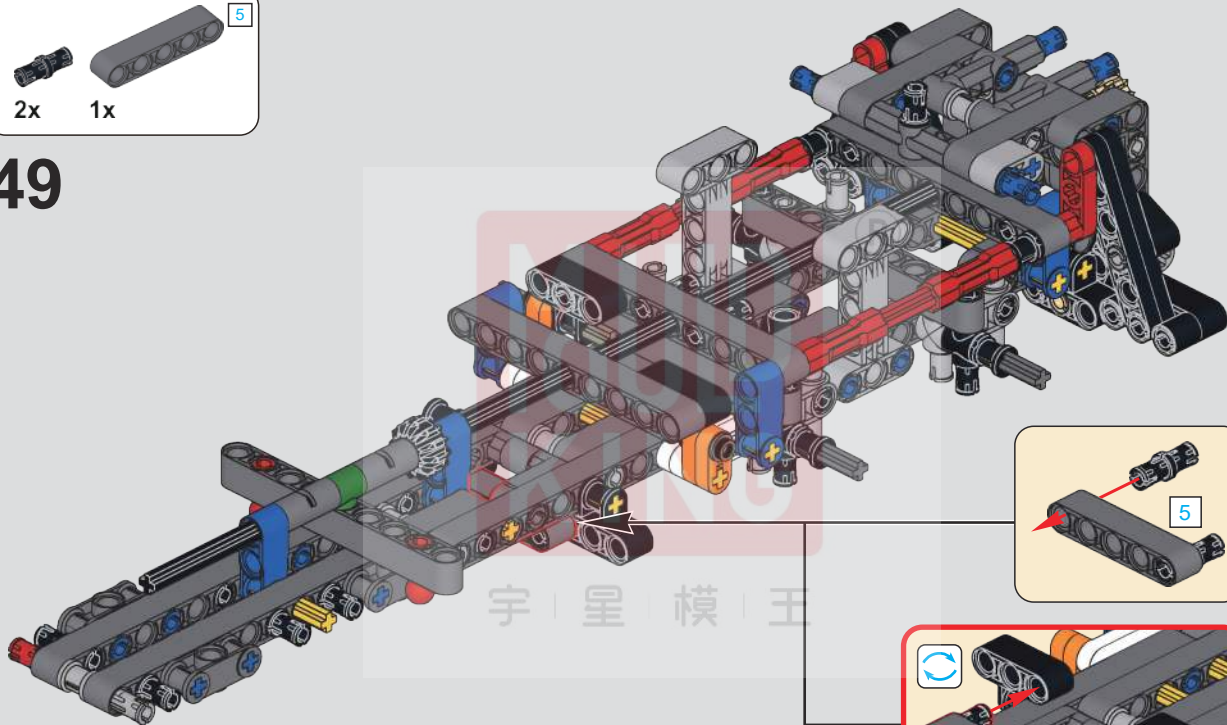

28



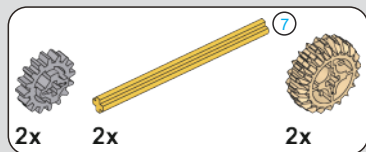

50

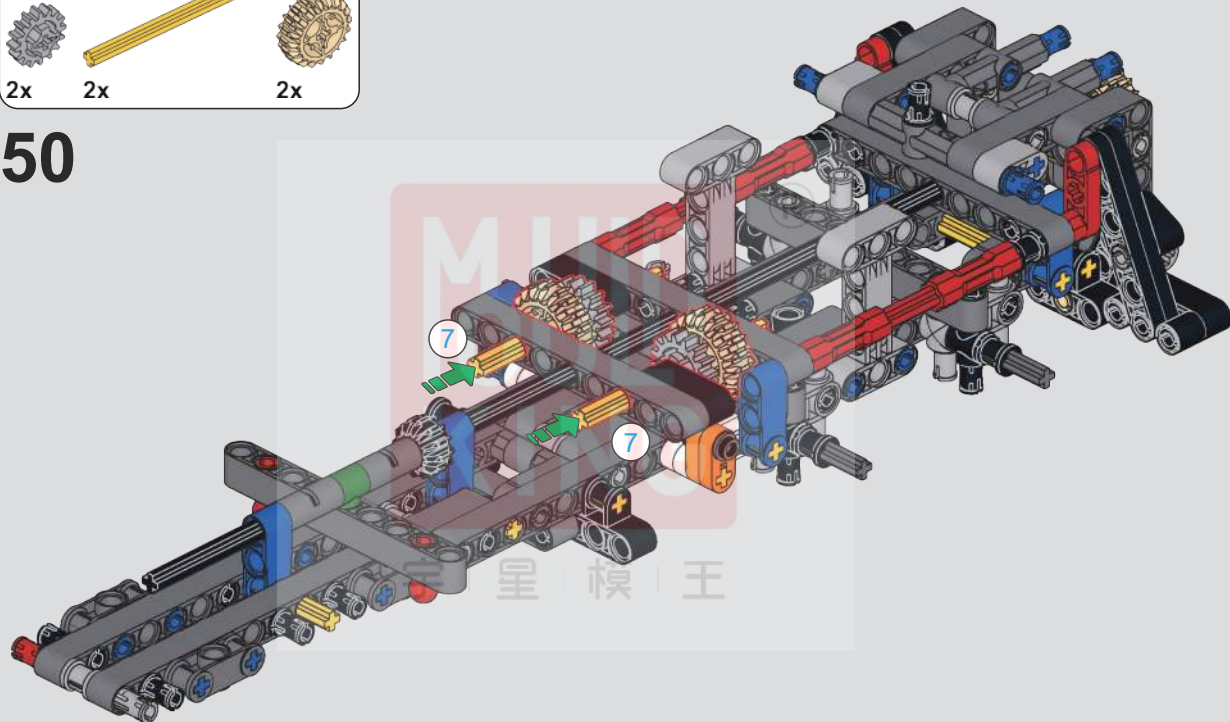

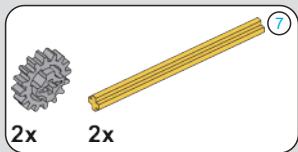

51

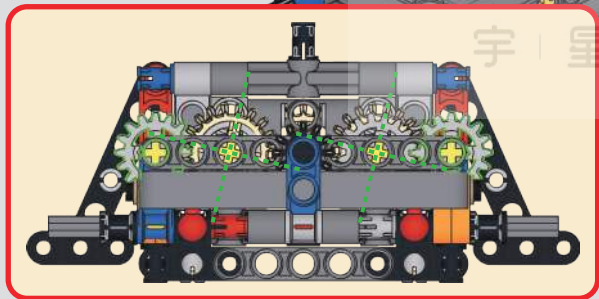
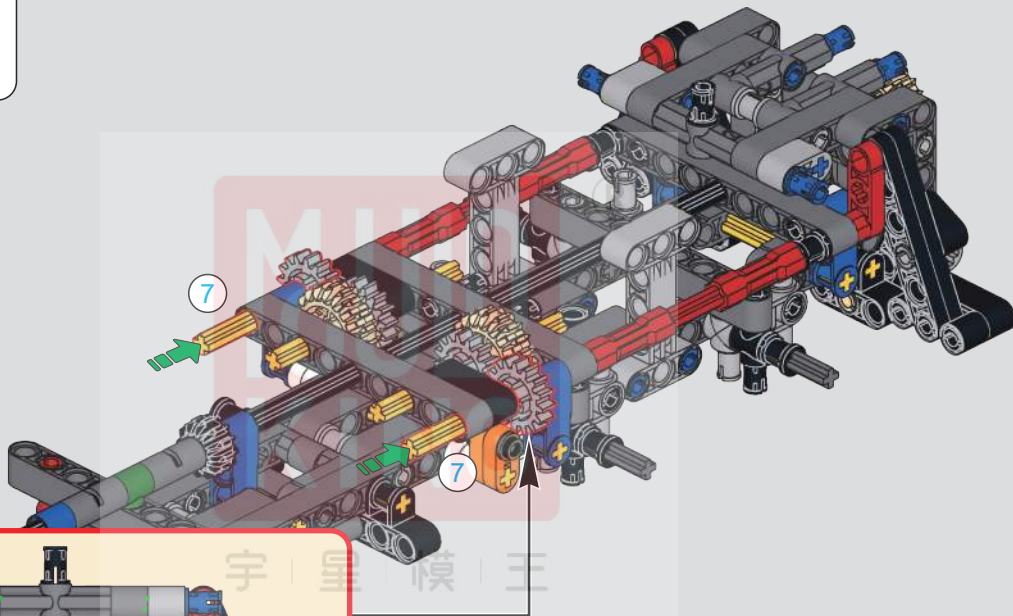

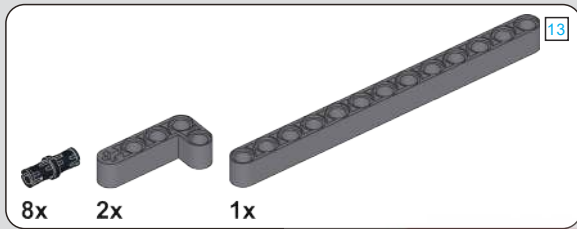

52

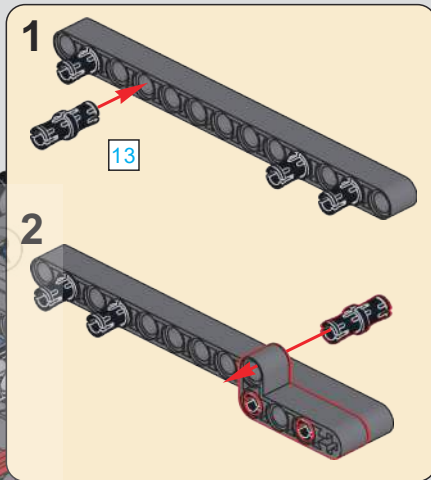
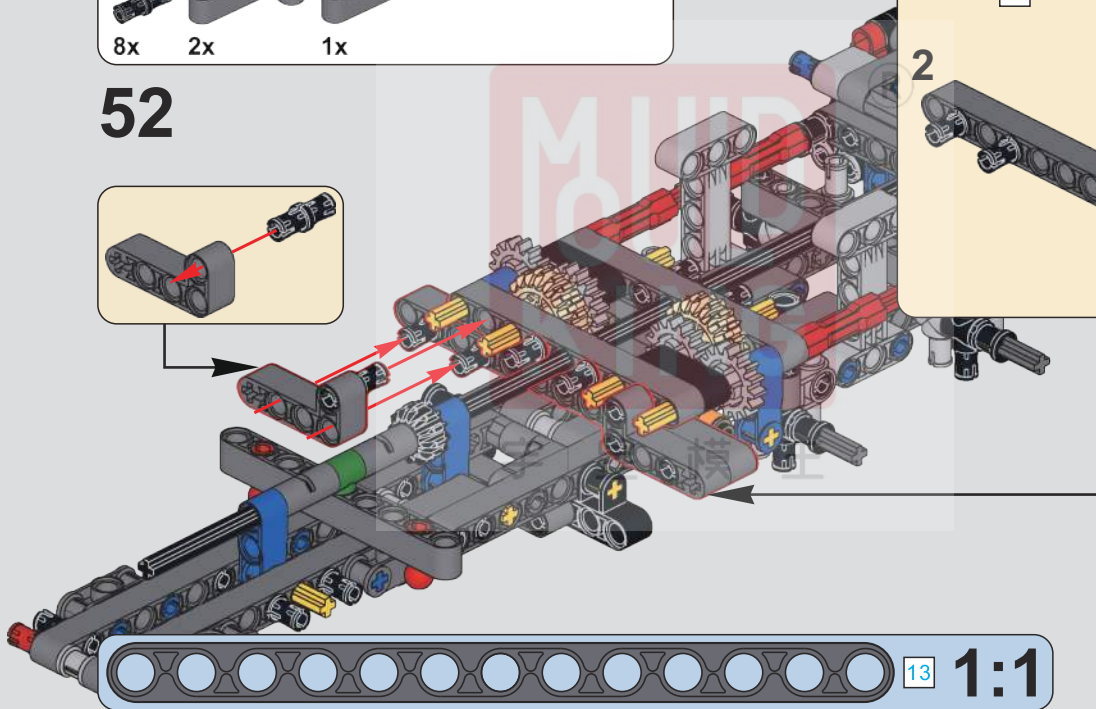
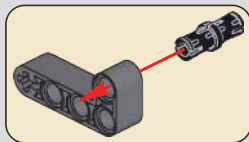

13 1:1



8x

53

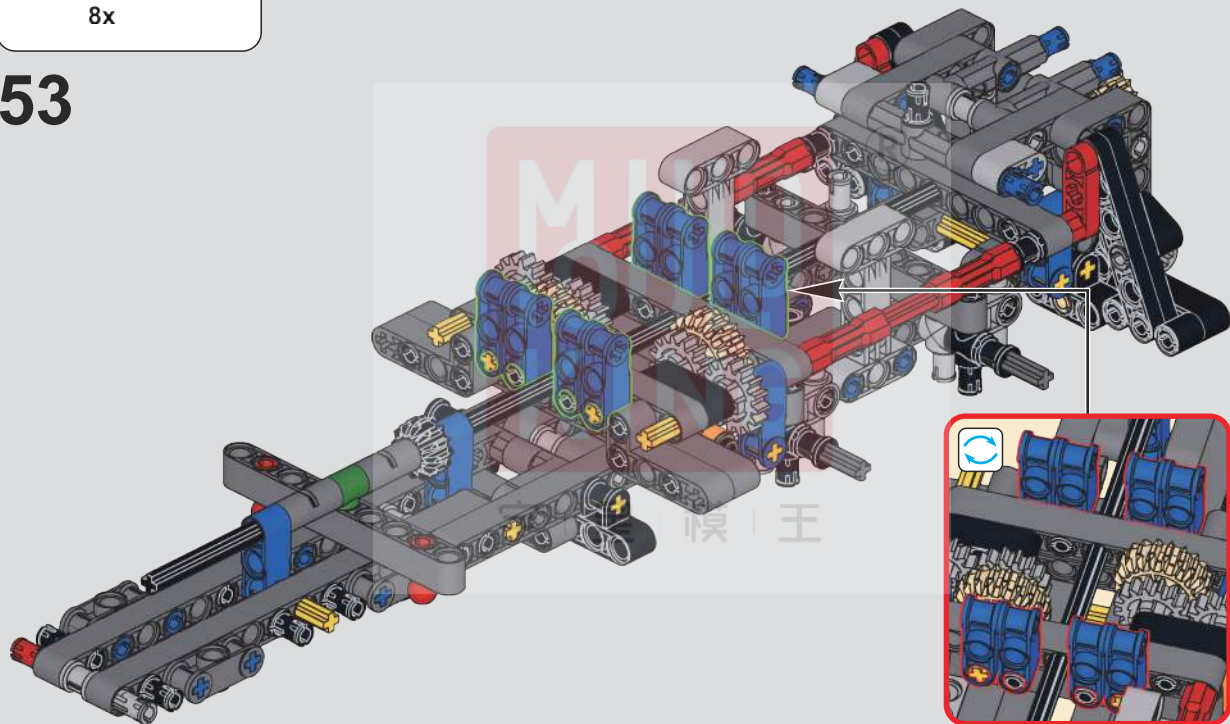

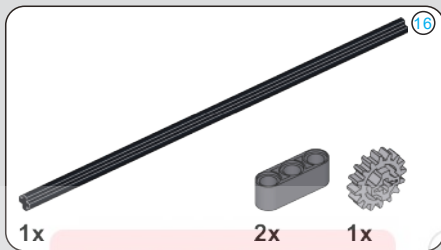
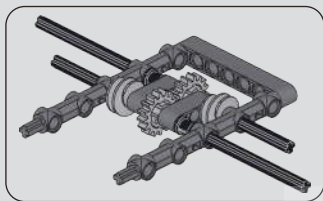

54

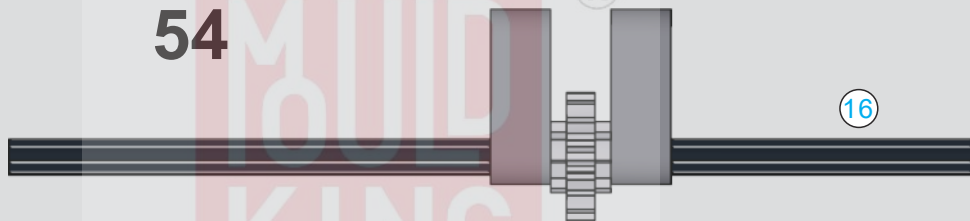

55

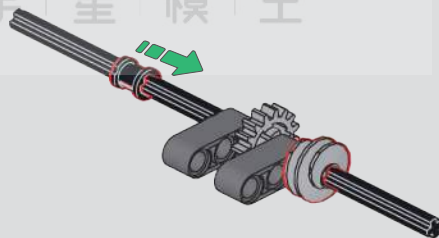

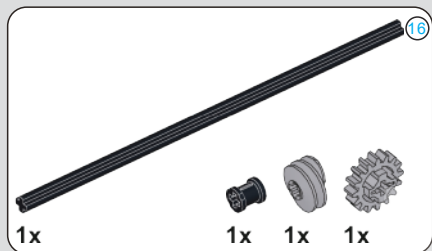

56

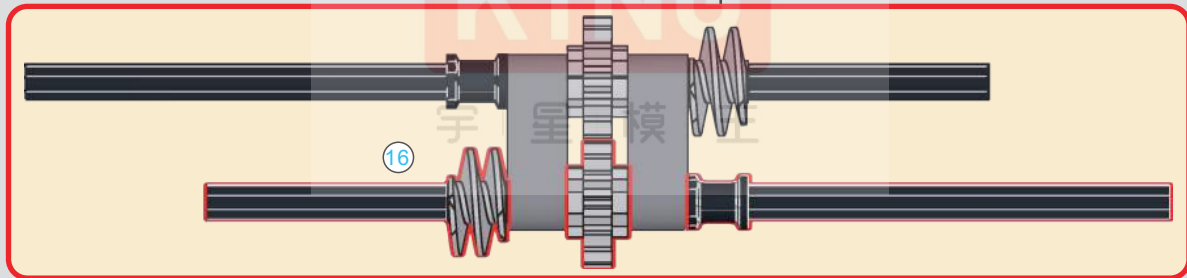
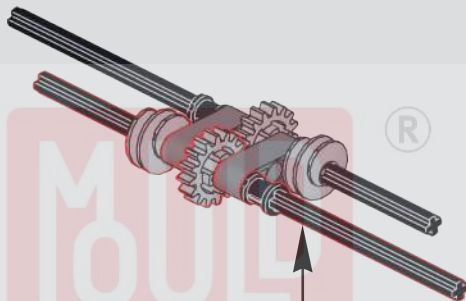

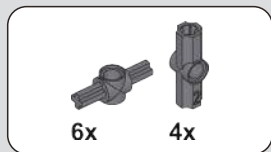

57

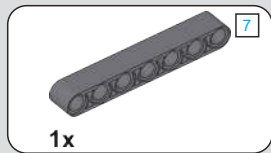
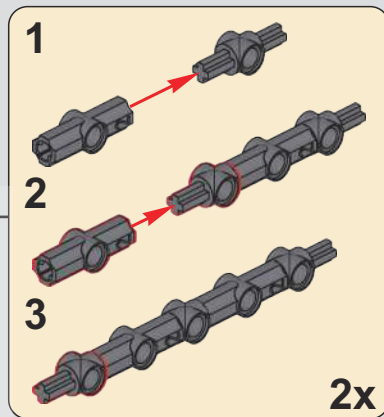
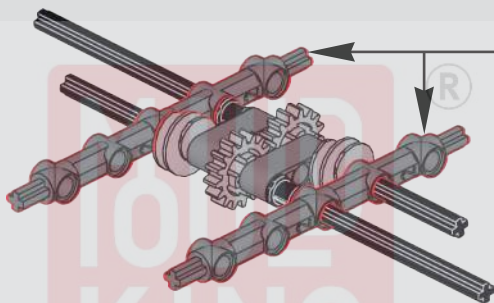

58

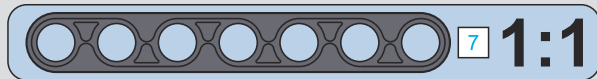
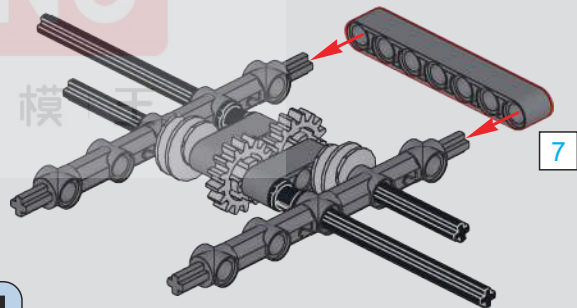

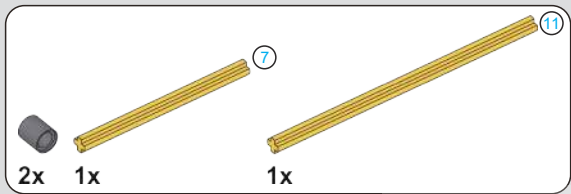

59

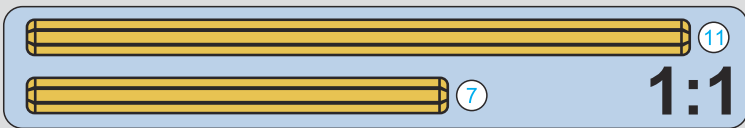
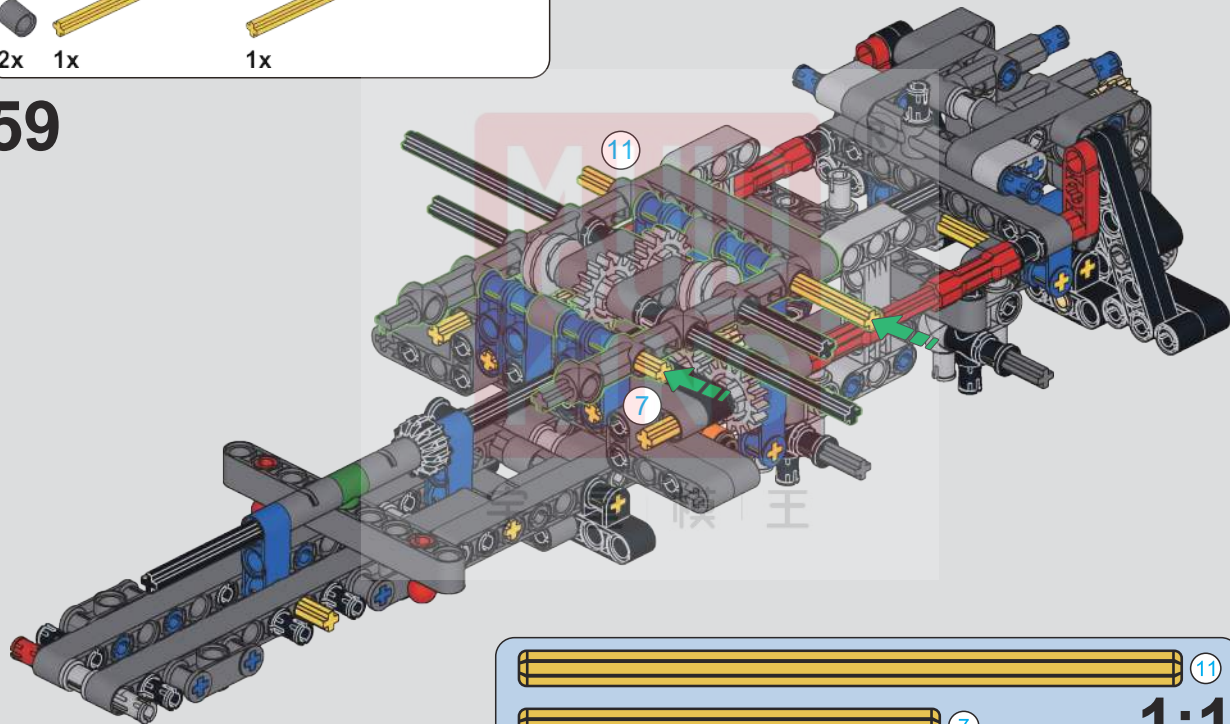

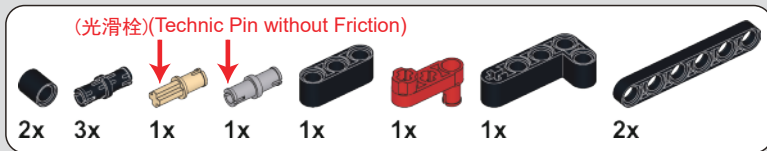

60

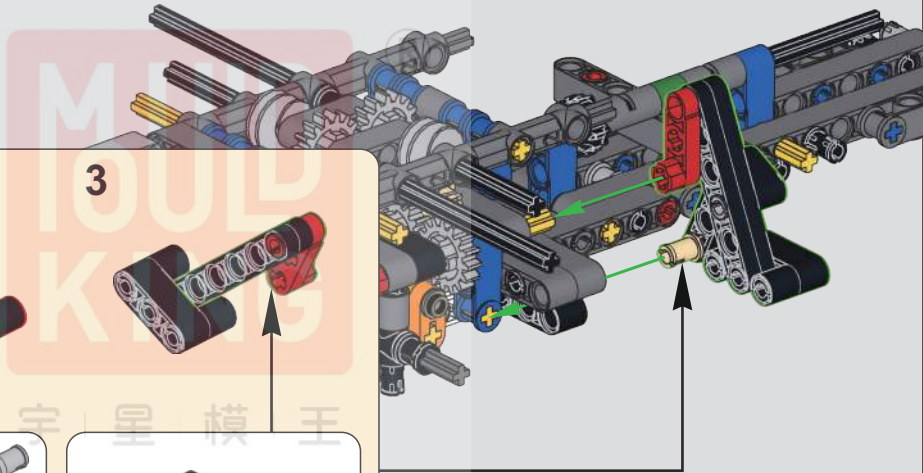
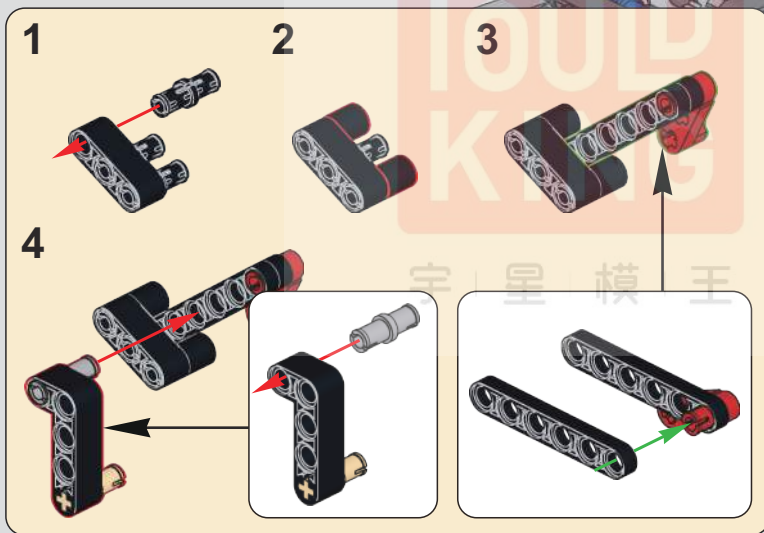

(光滑栓)(Technic Pin without Friction)



61

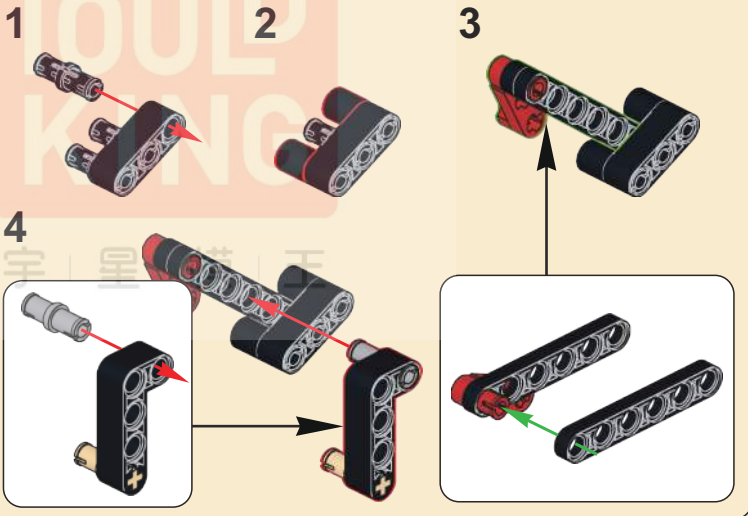
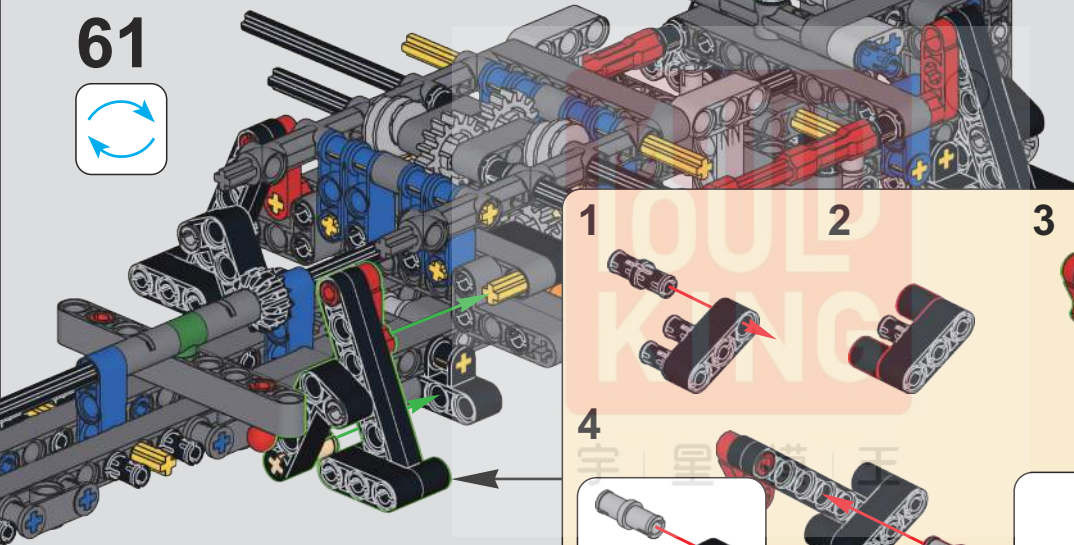

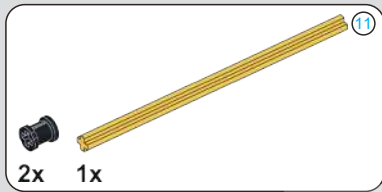

62

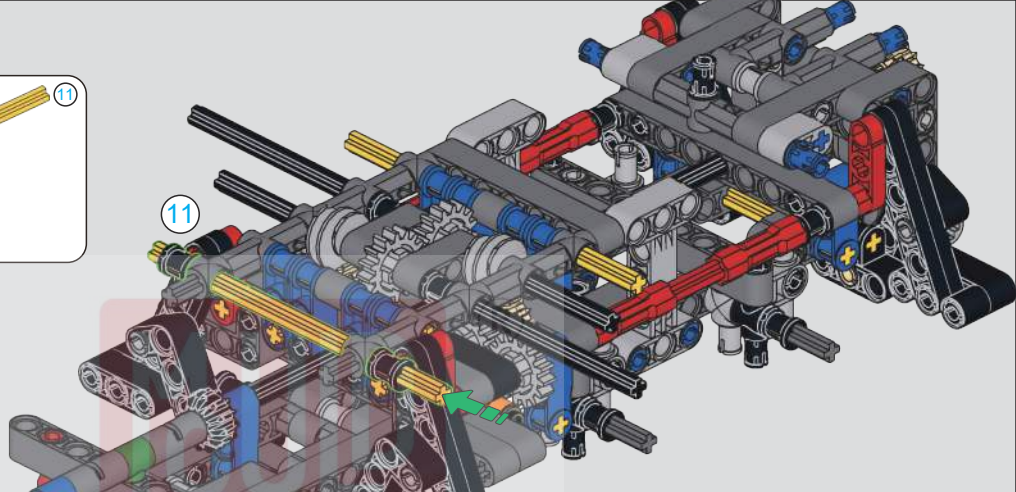

63

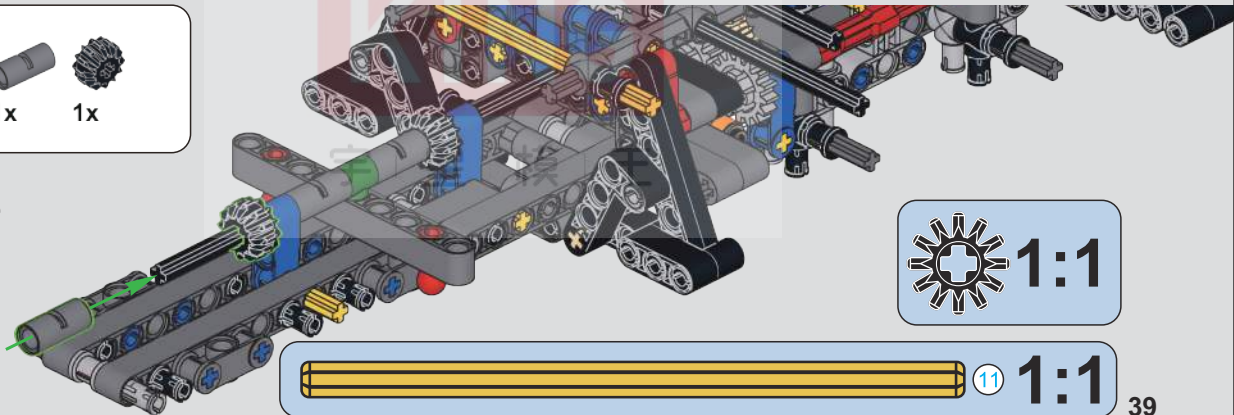

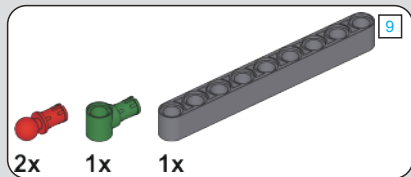

64

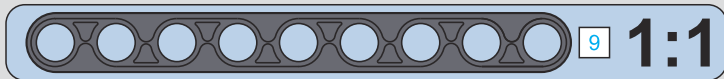
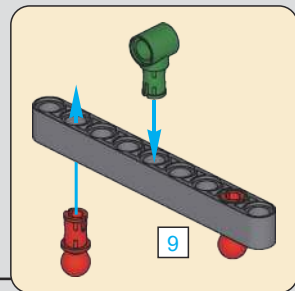
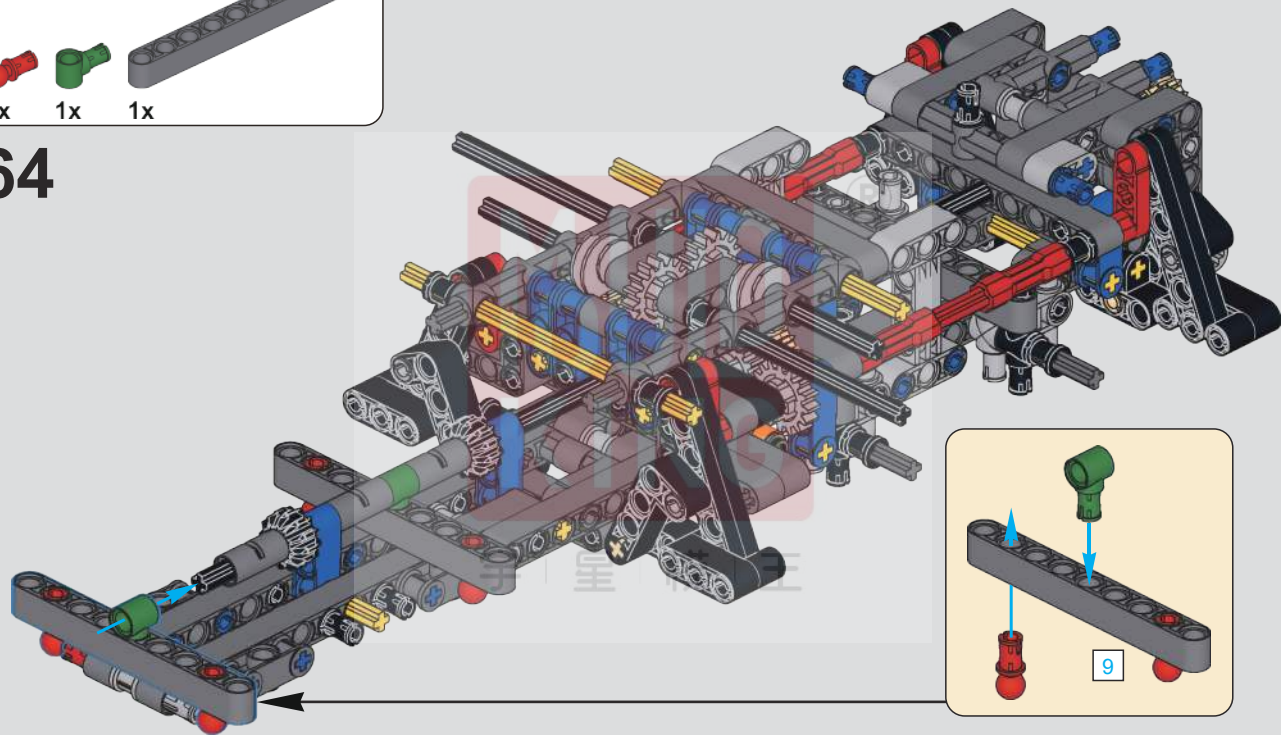

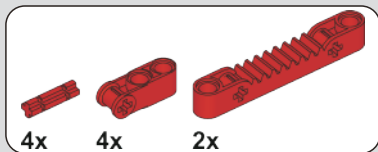

65

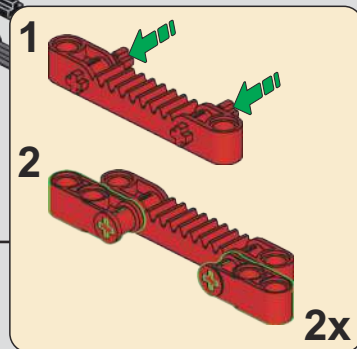
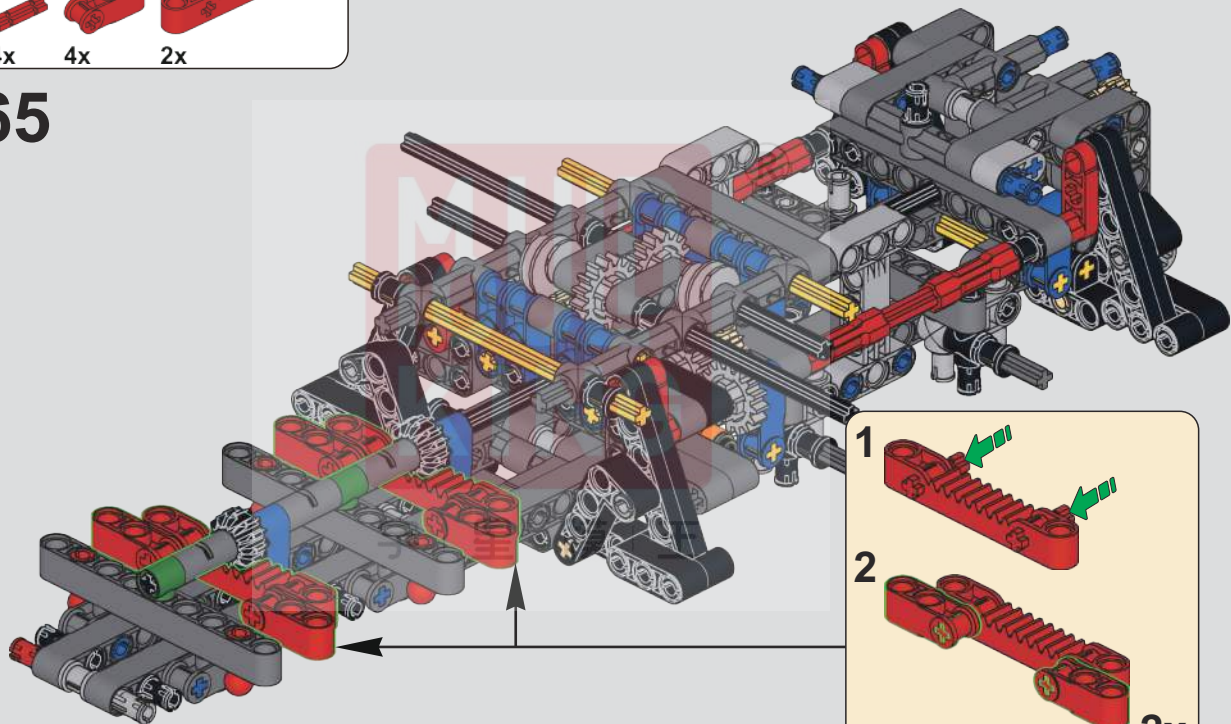

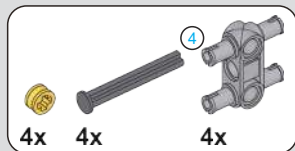

66

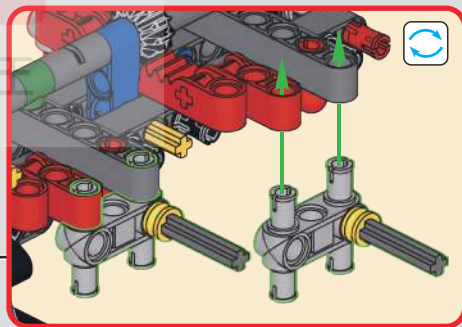
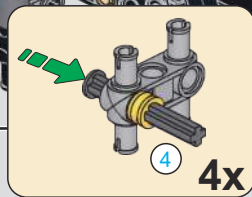
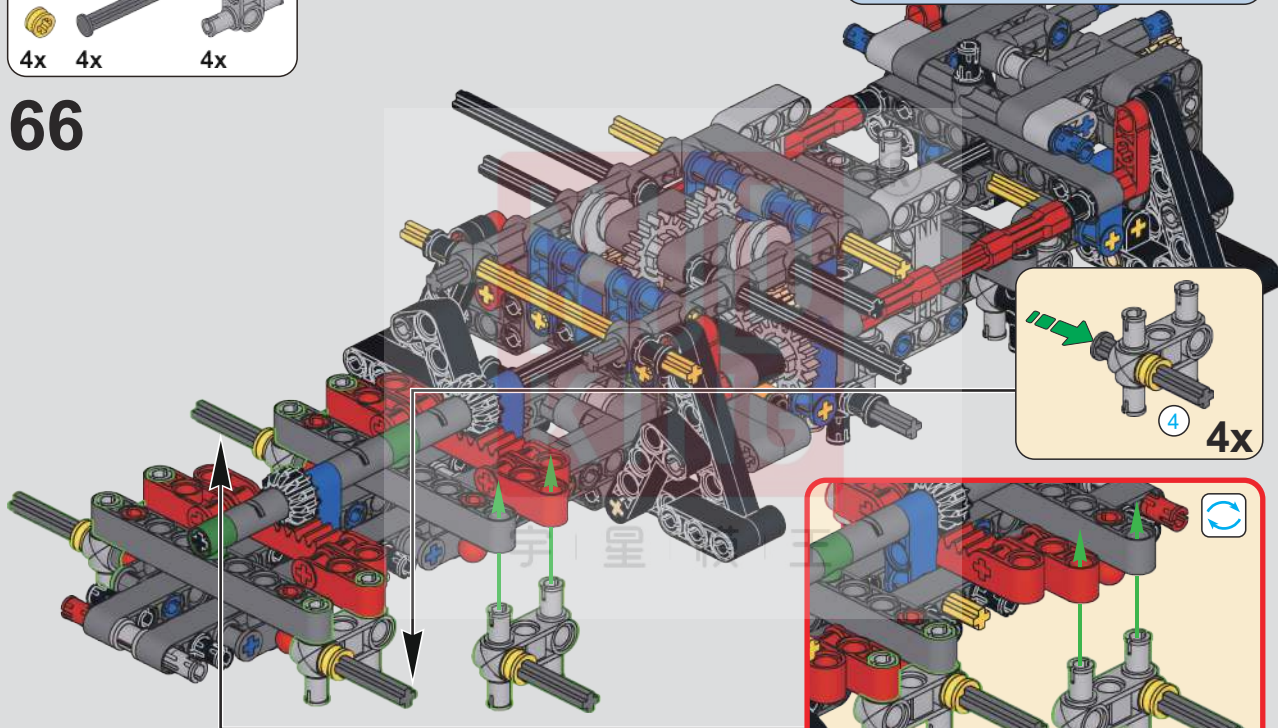
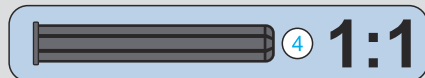

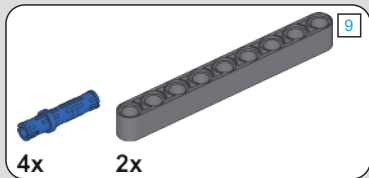

67

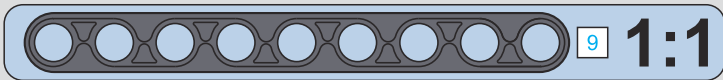
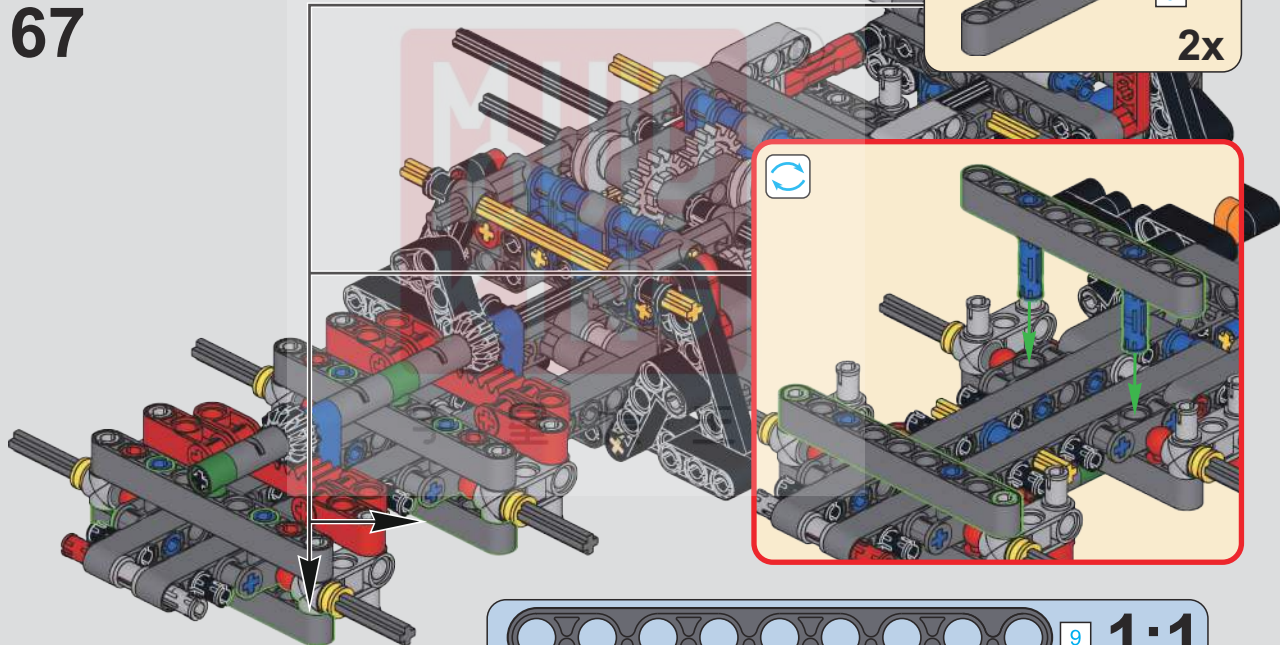
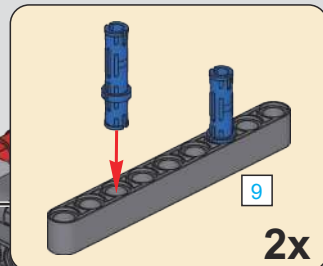

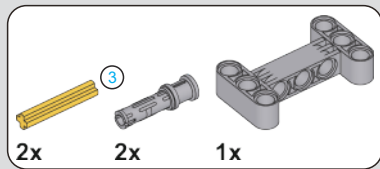

68

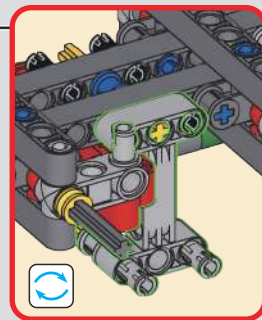
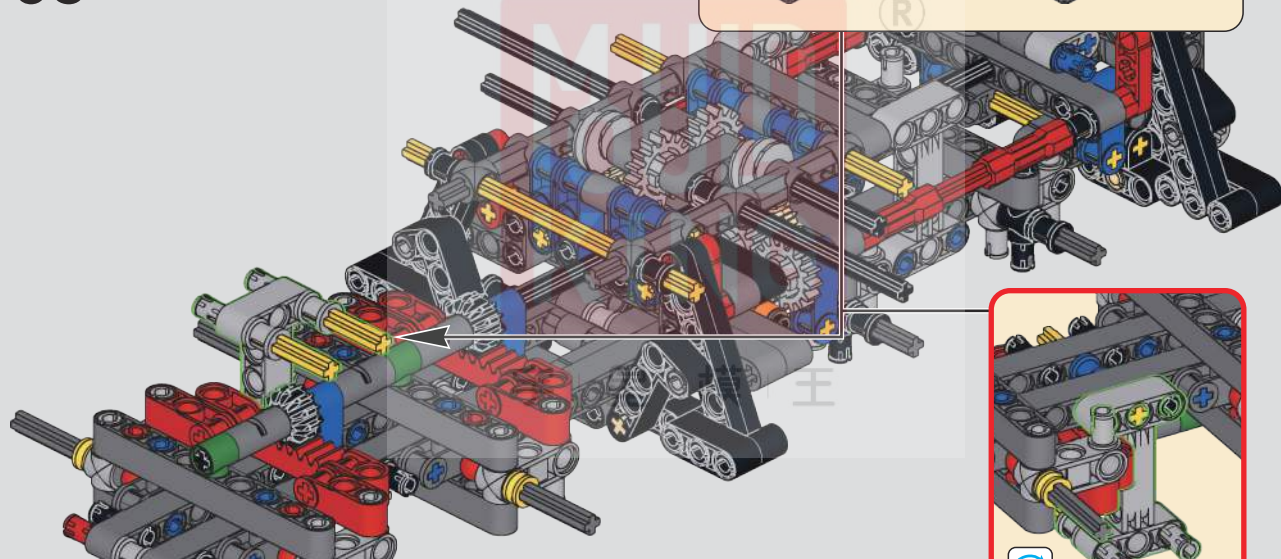
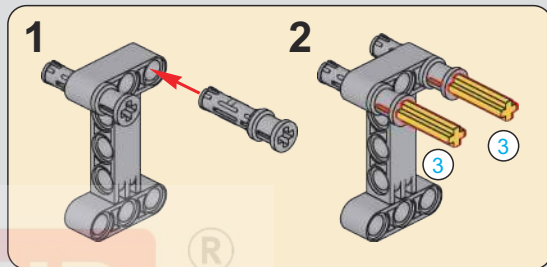

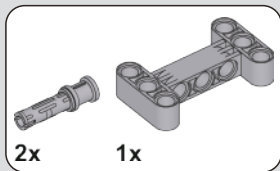

69

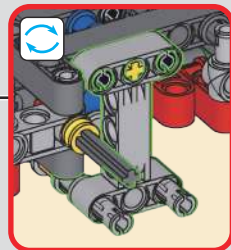
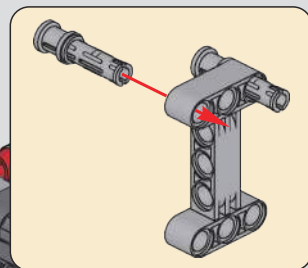
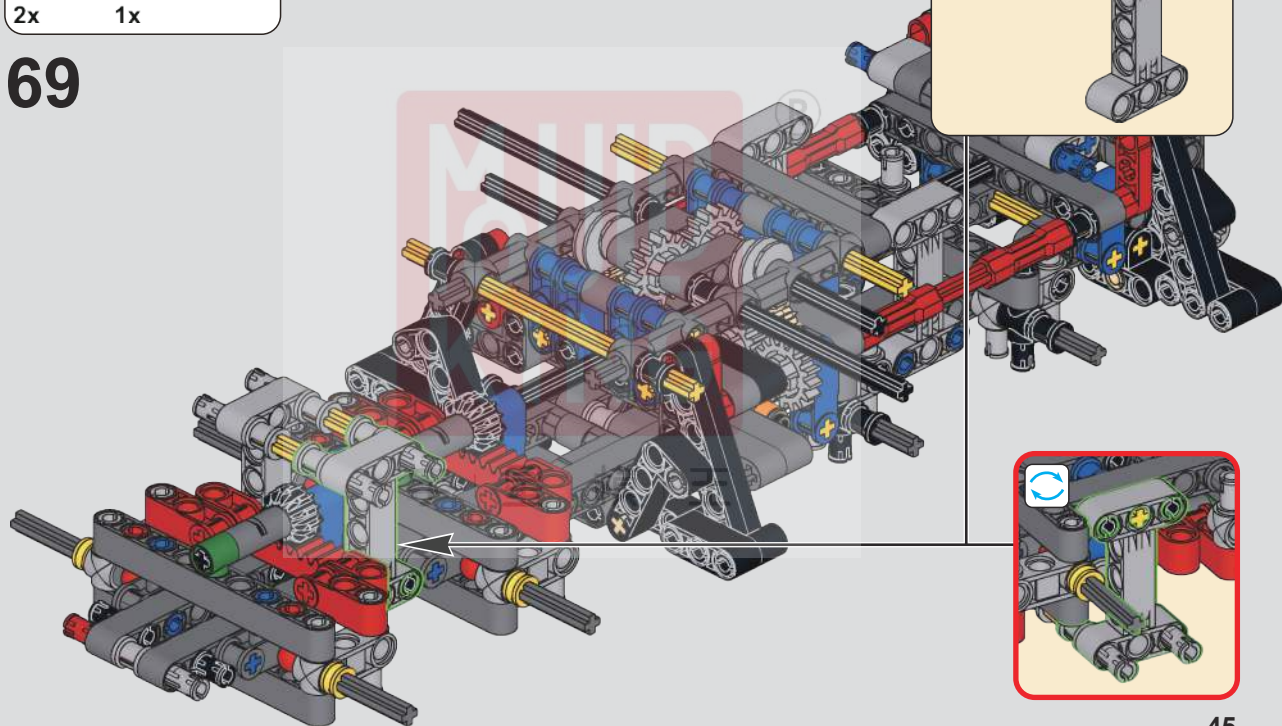

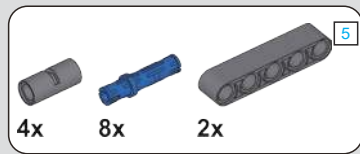
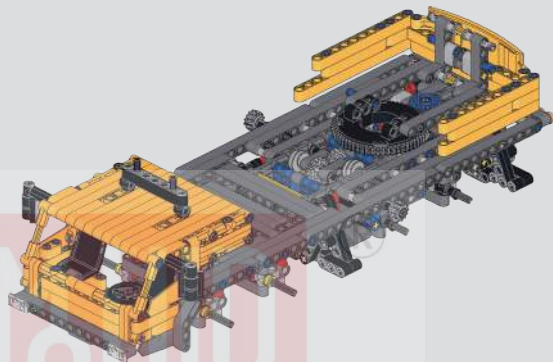

70

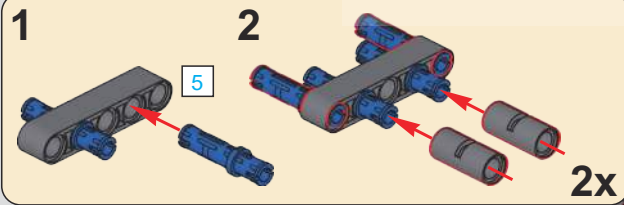

46

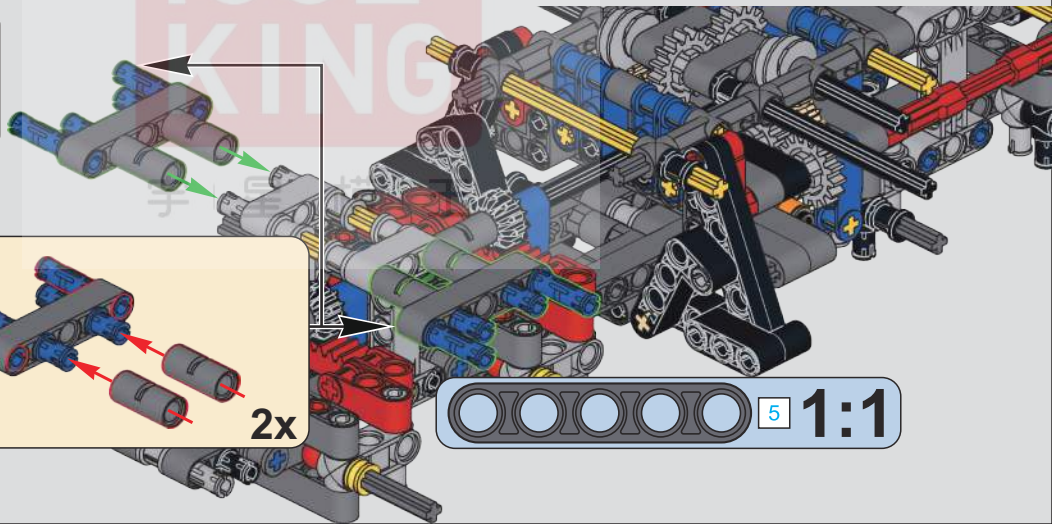

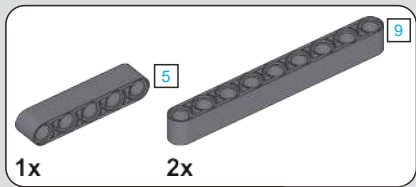

71

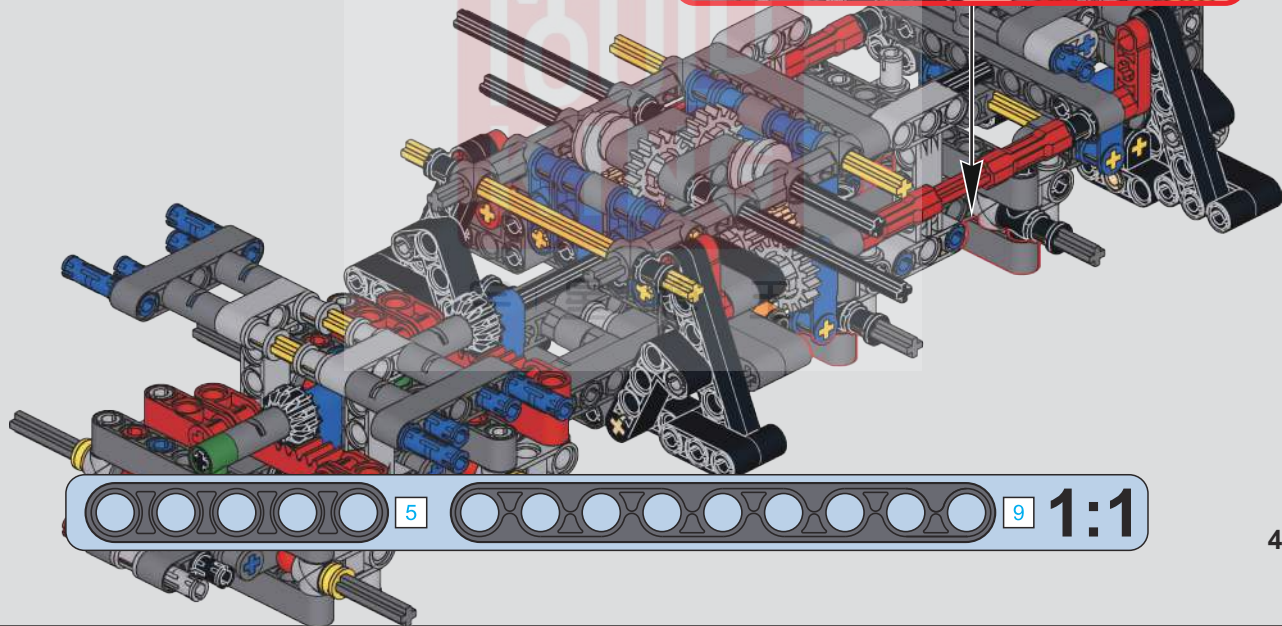
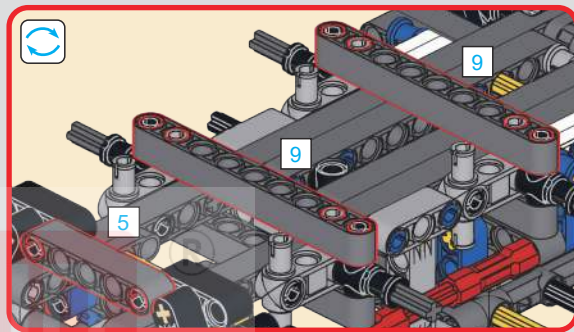

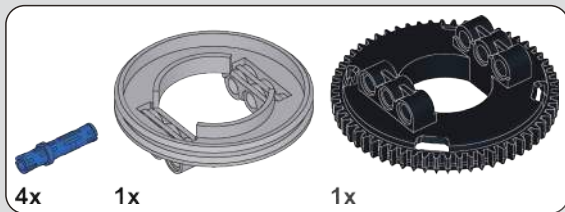

73

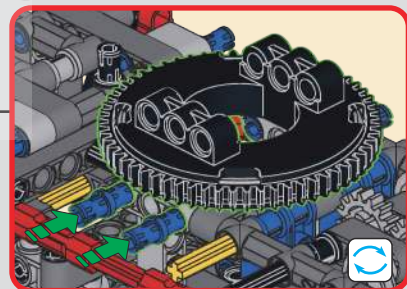
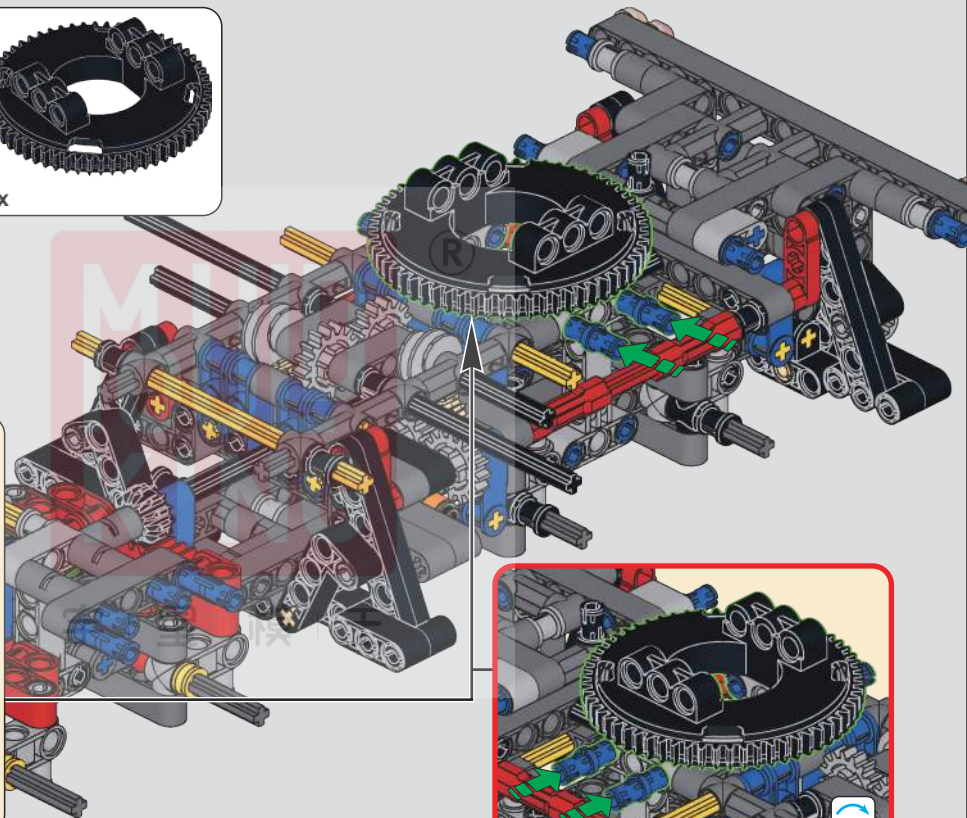
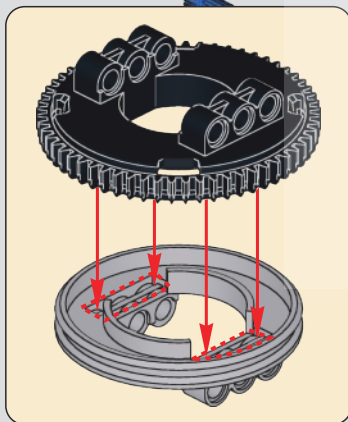

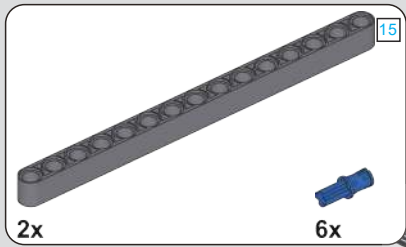

74

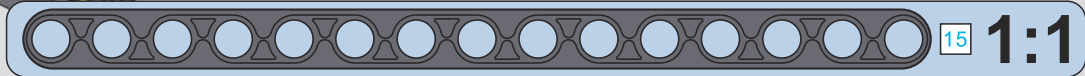
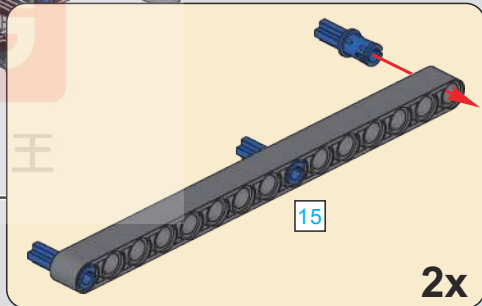
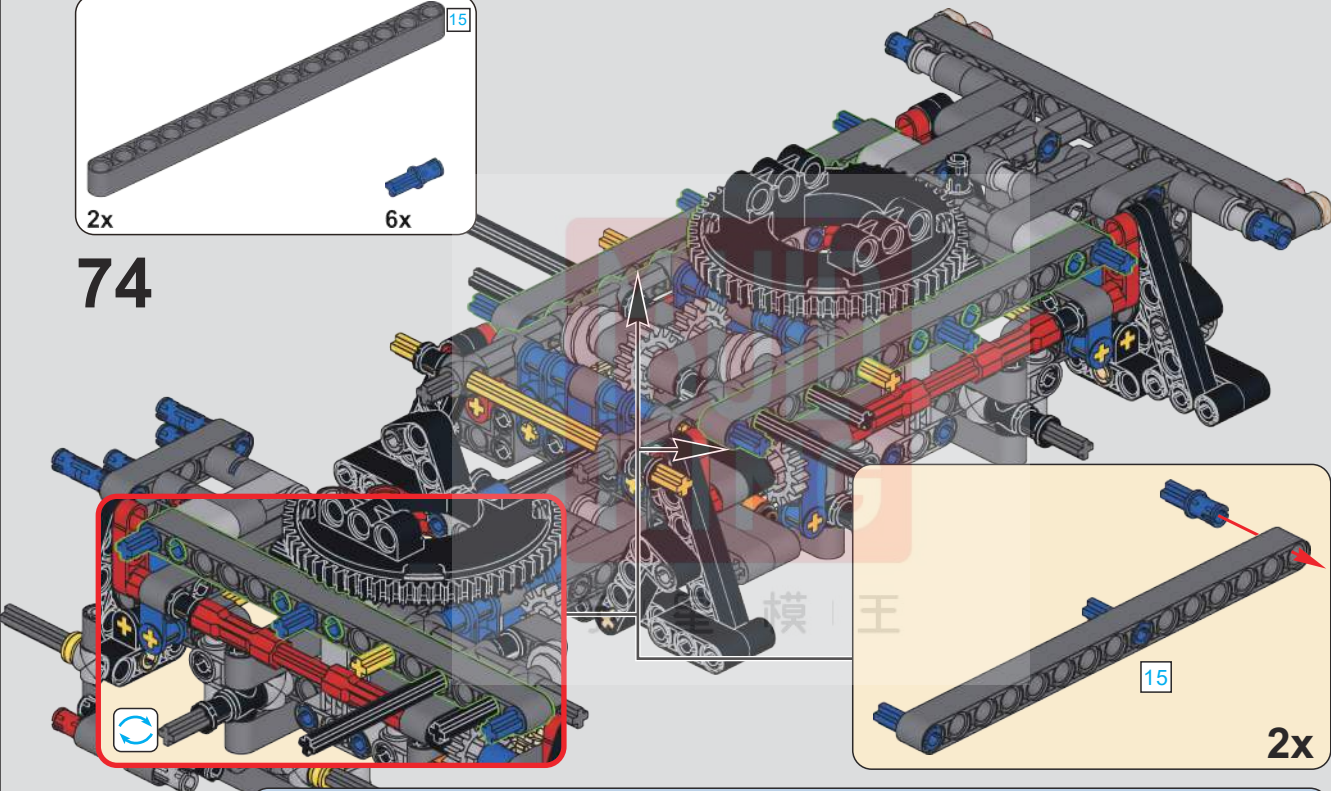

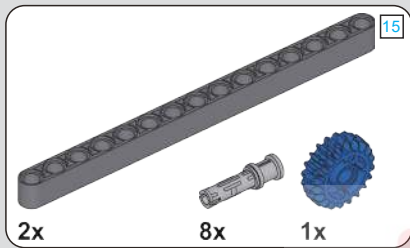

75

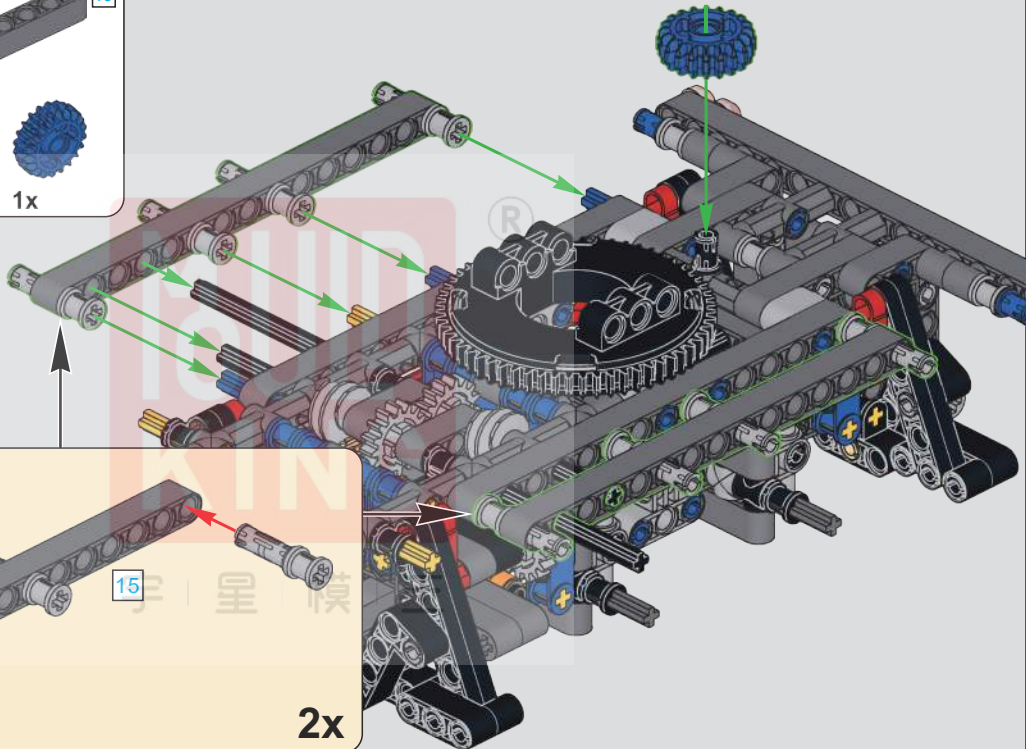
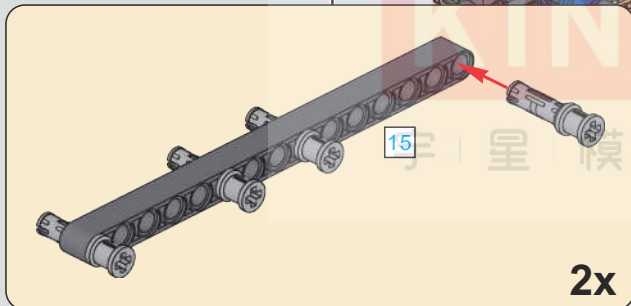

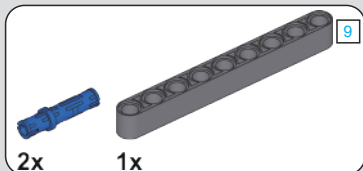
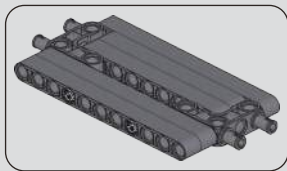

76

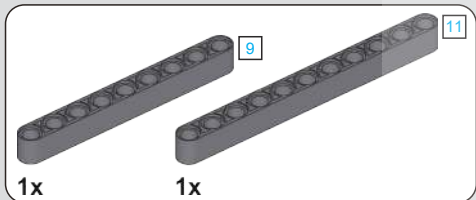
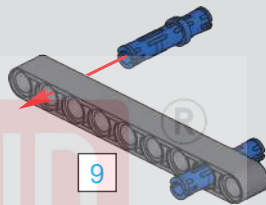

77

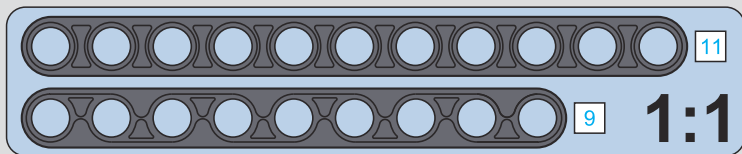
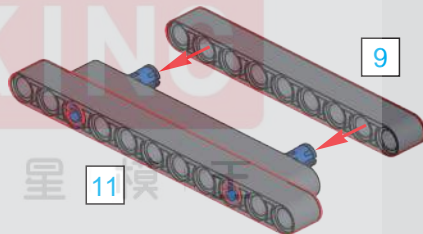

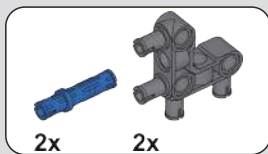

78

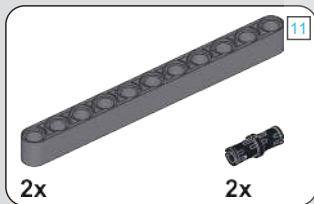
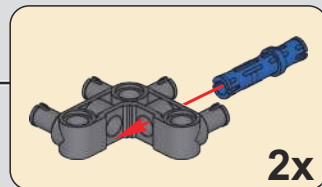
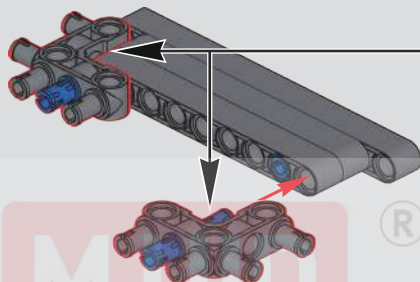

79

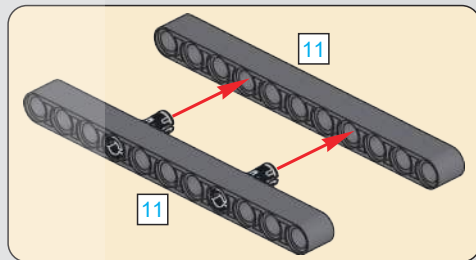
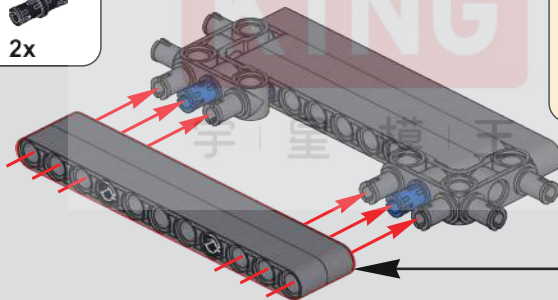

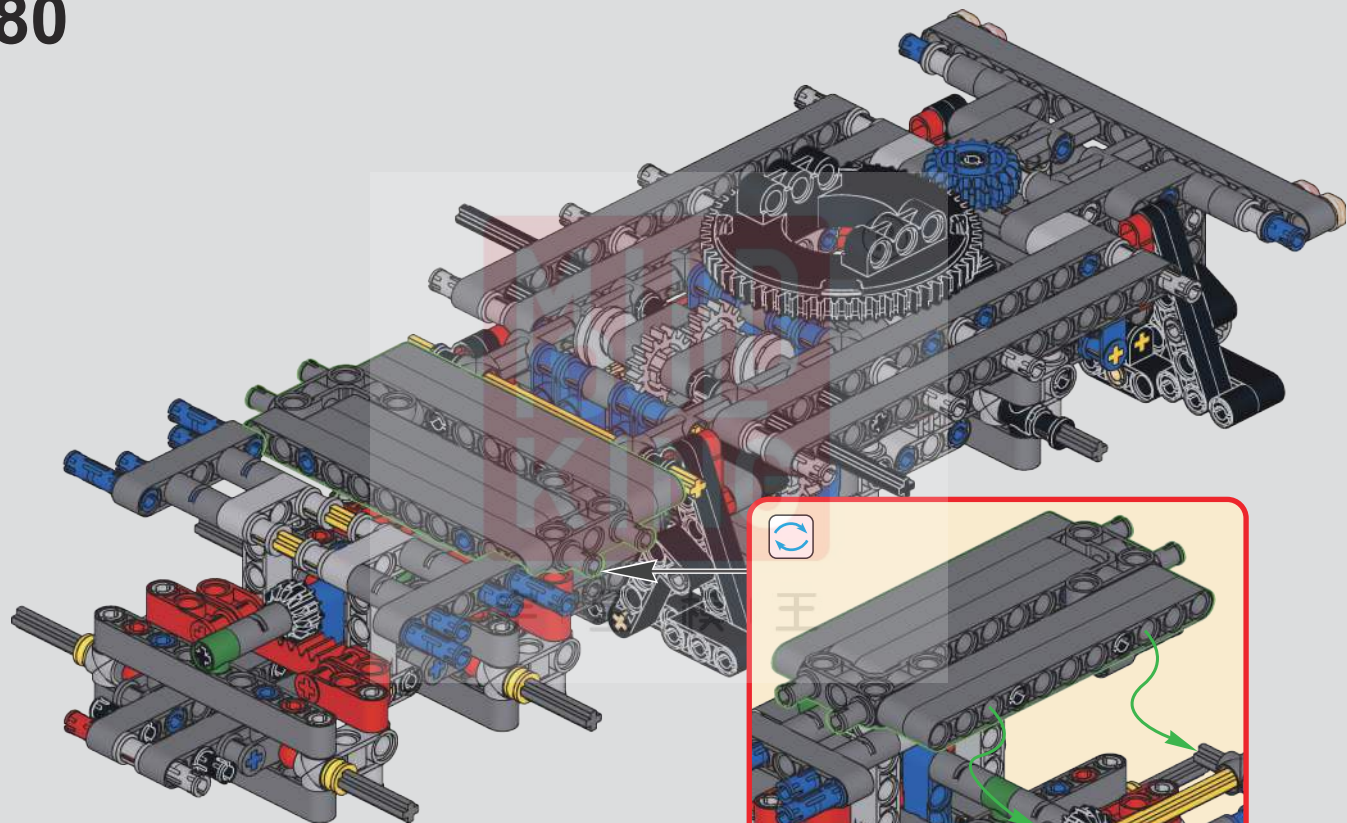

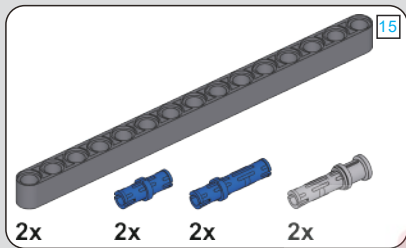

81

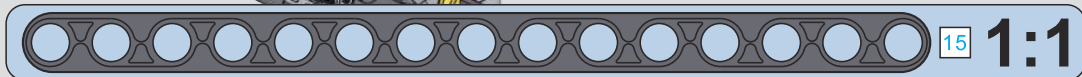
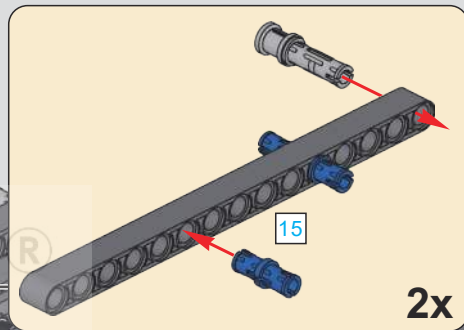
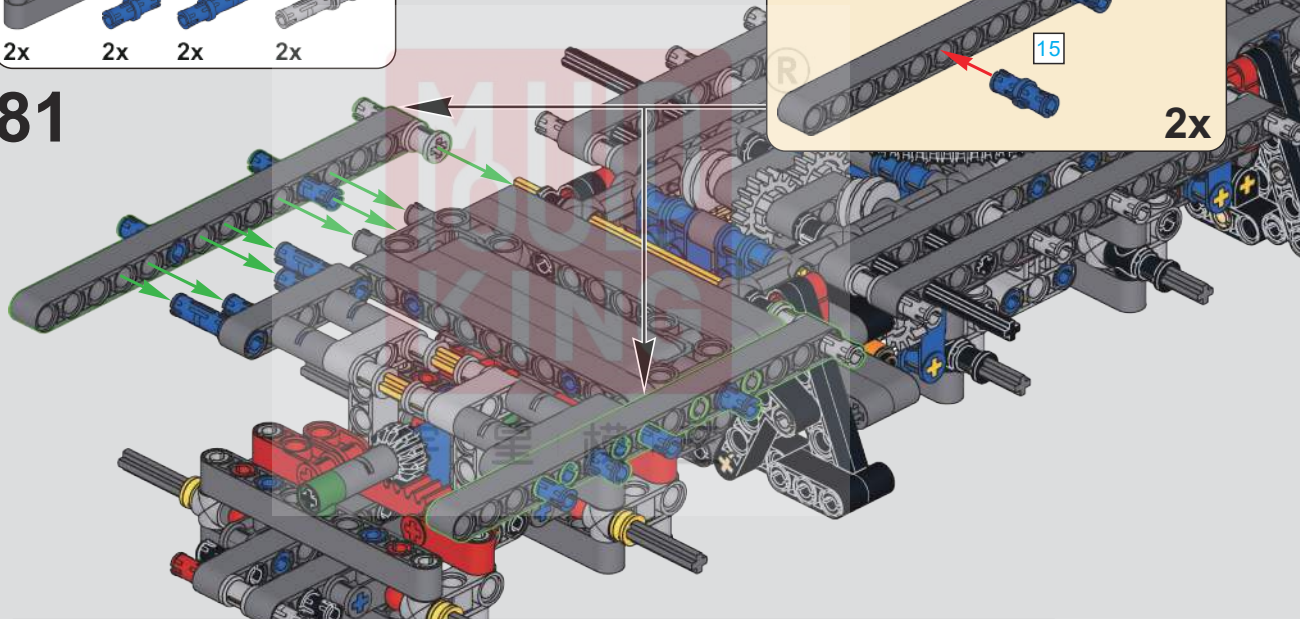

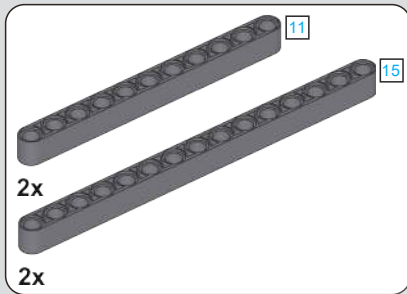

82

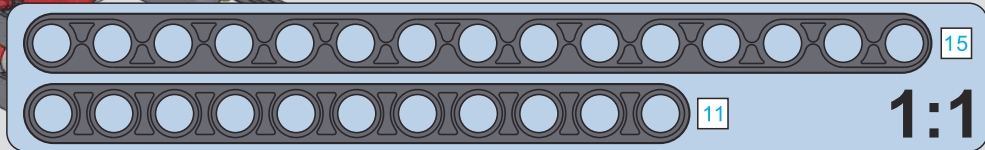
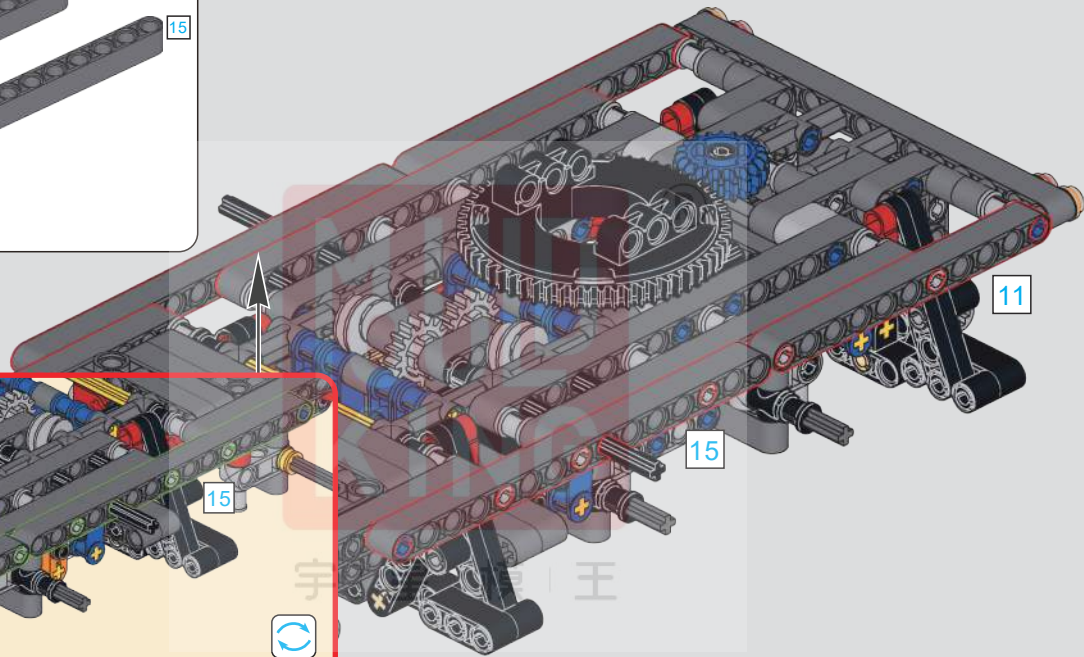
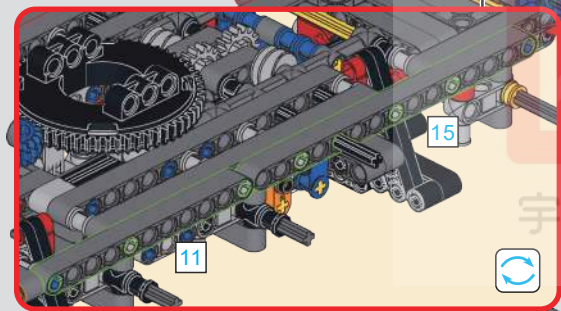

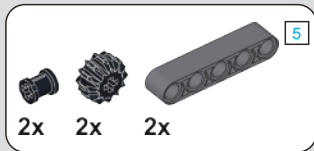

83

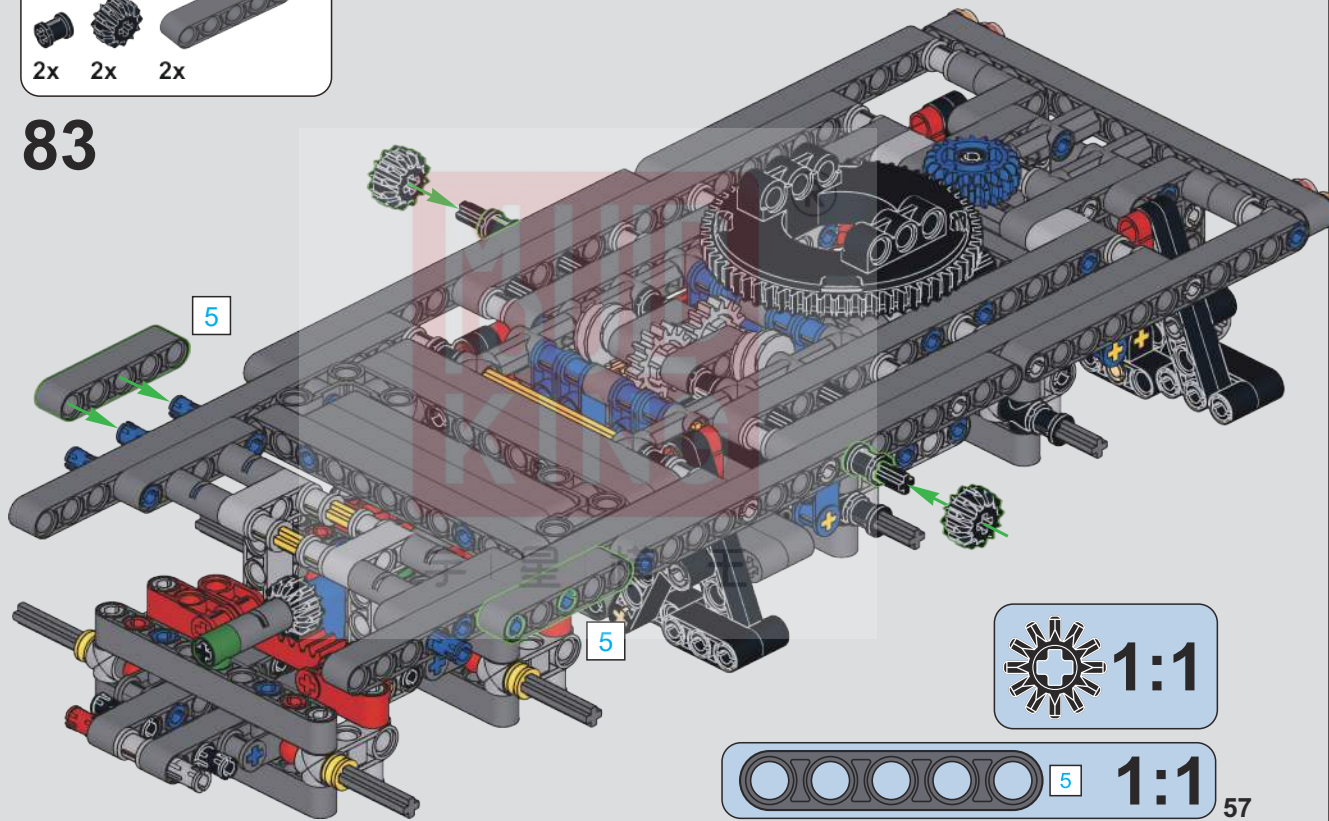

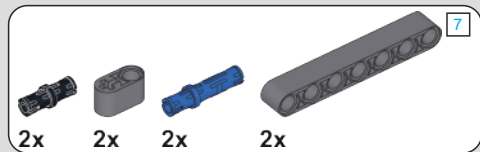

84

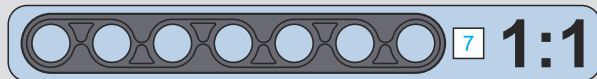
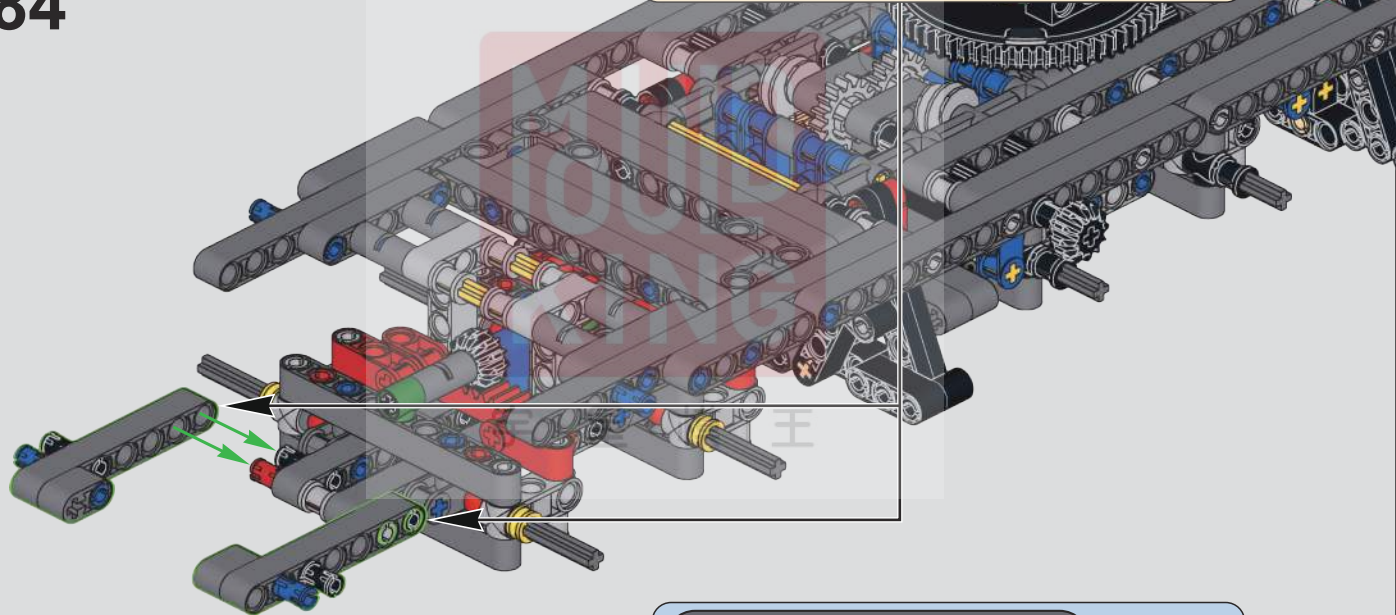
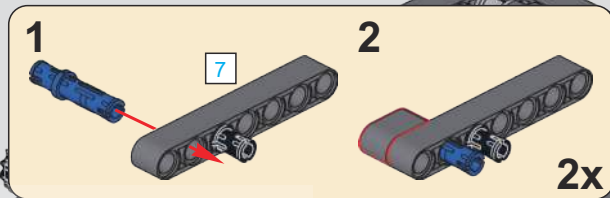

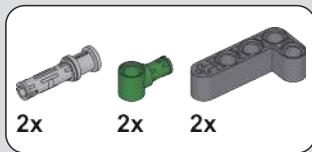

85

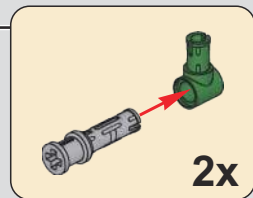
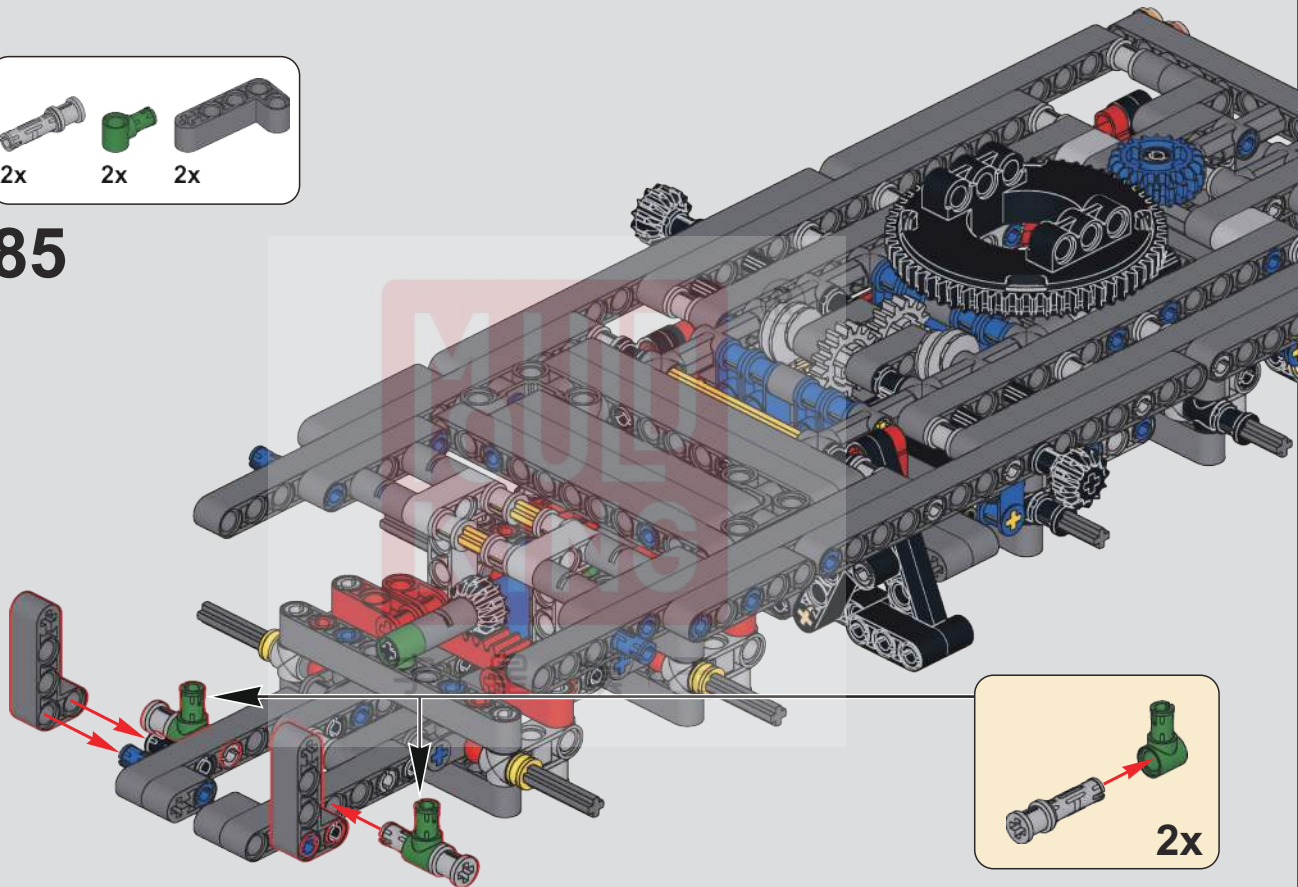

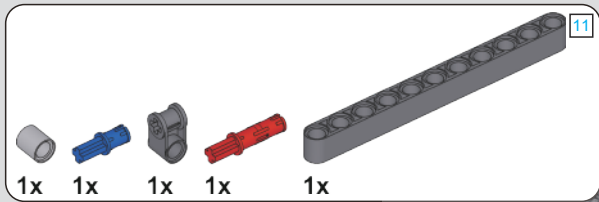

86

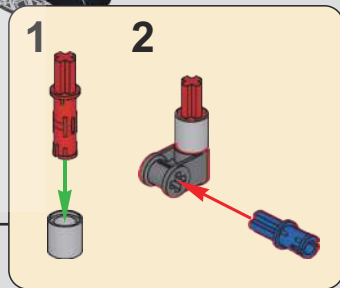
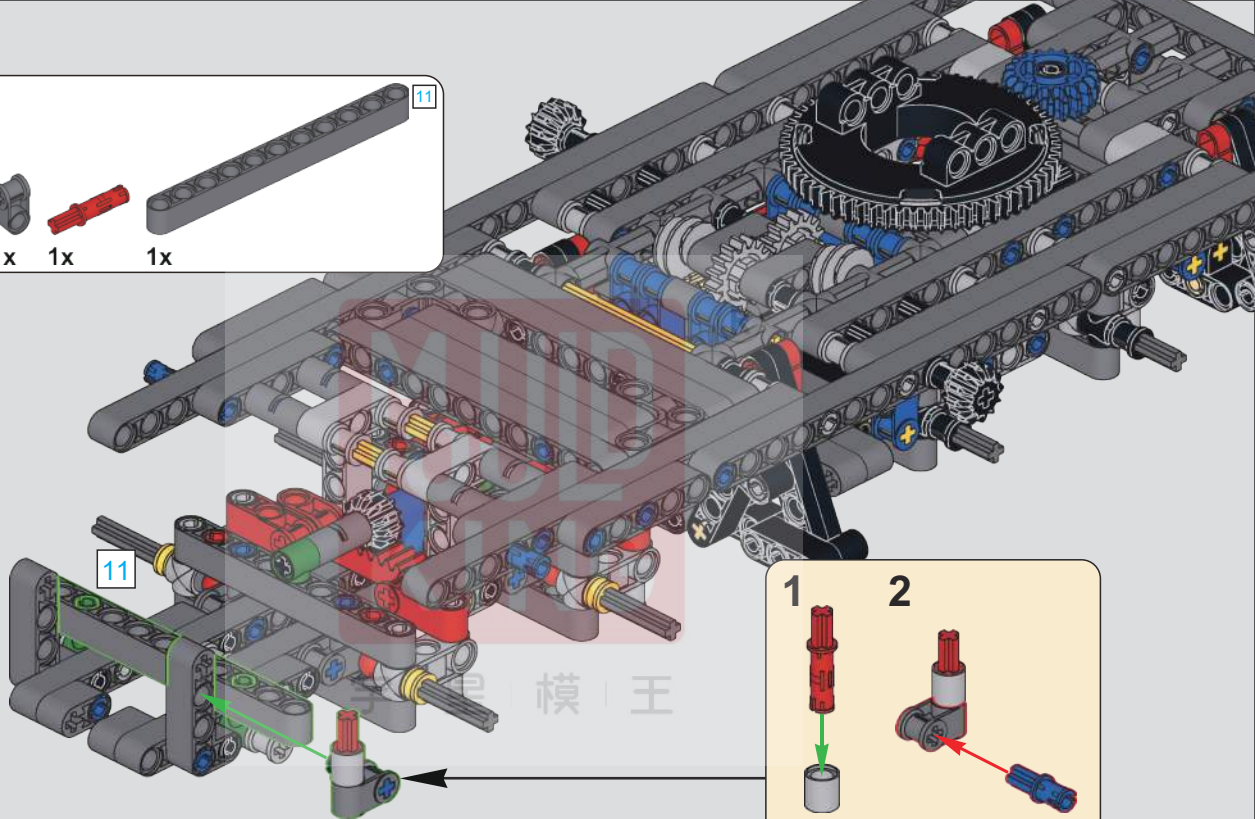

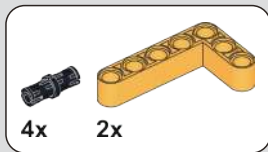

87

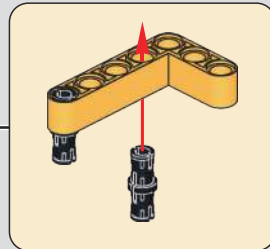
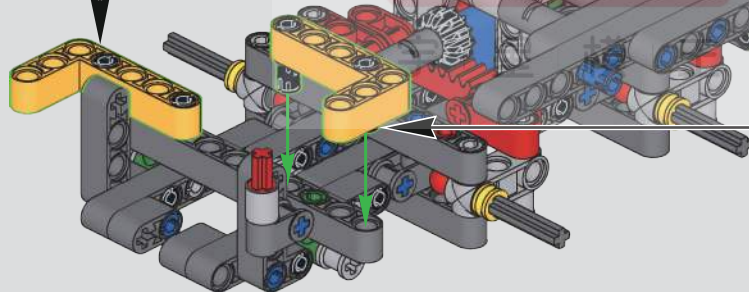
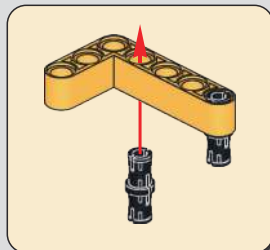



88

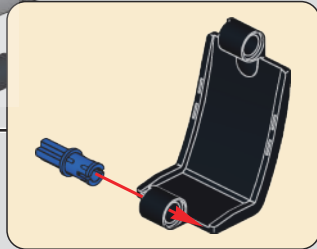
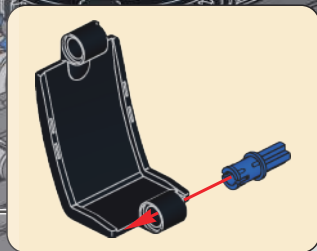
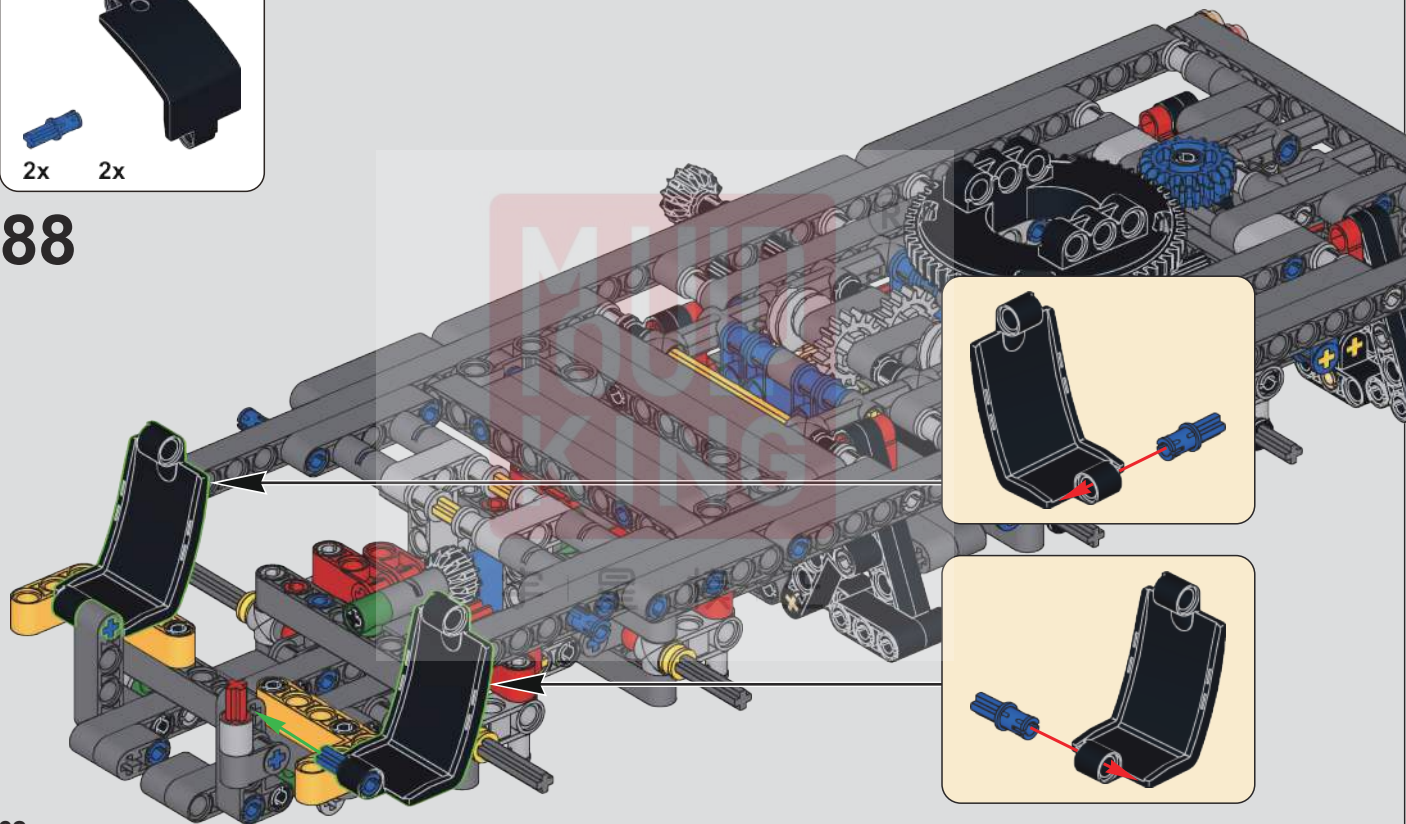

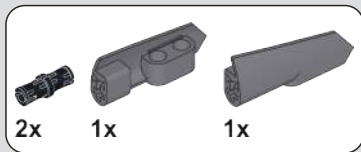

89

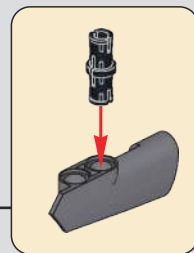
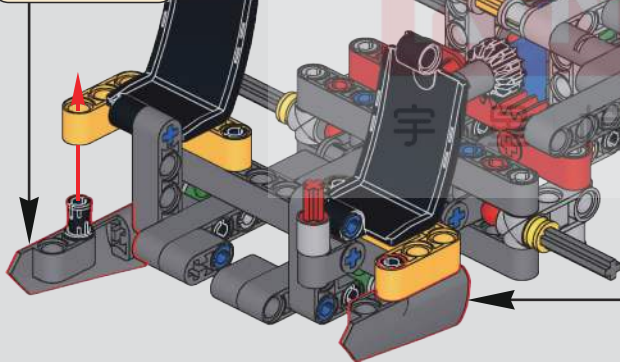
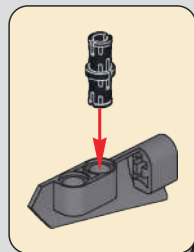

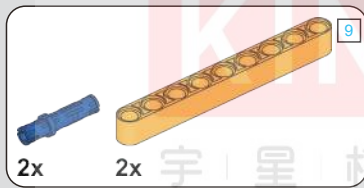
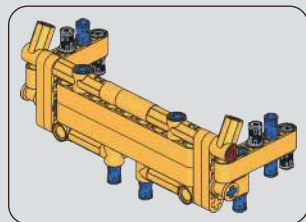
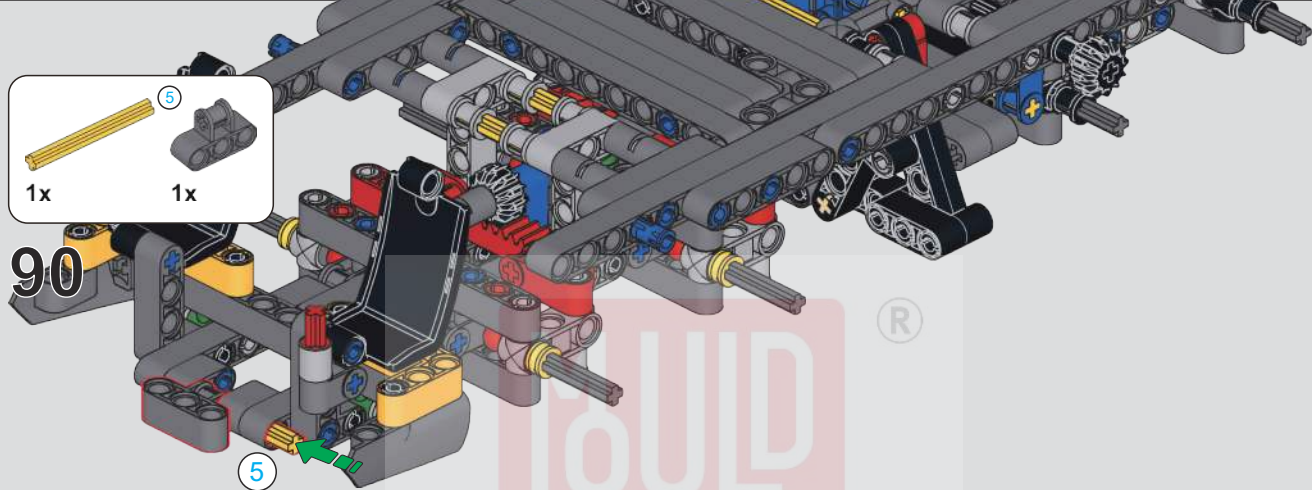

91

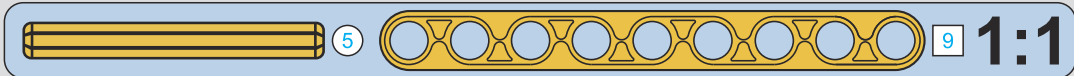
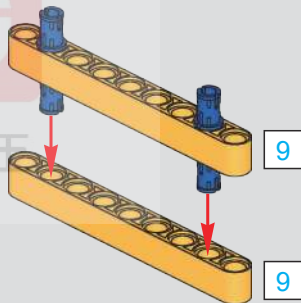

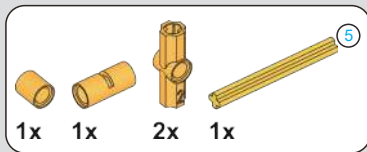

92

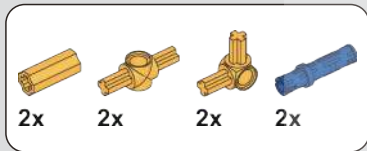
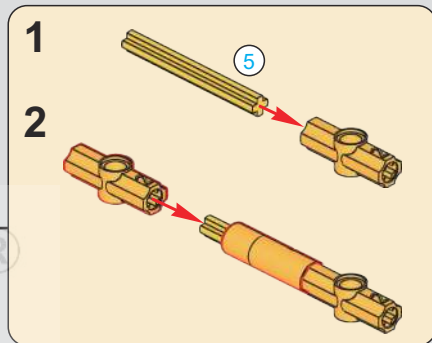
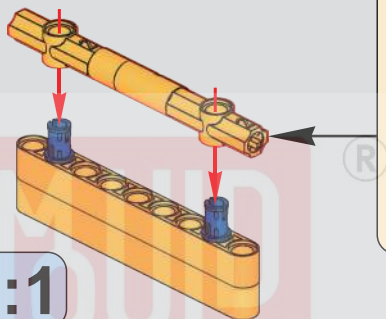
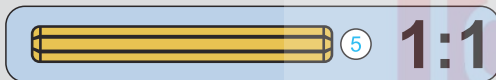

93

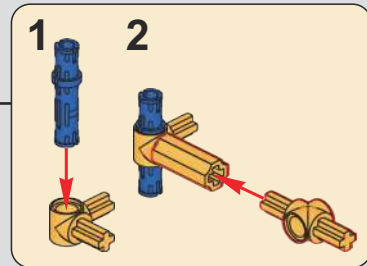
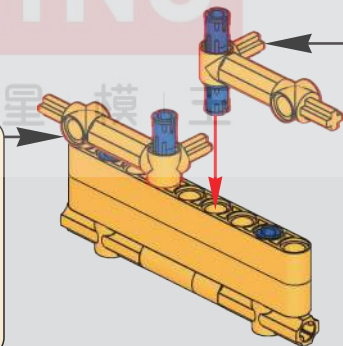
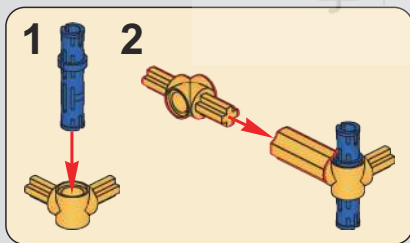



94

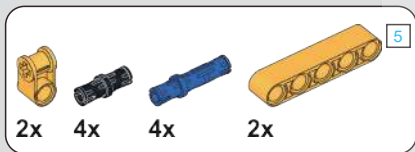
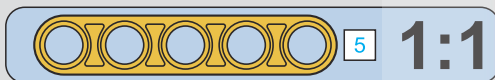
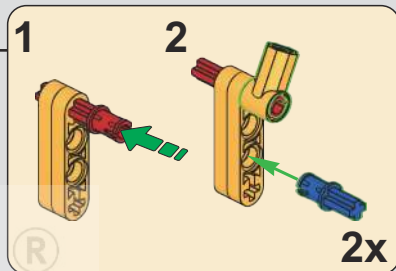
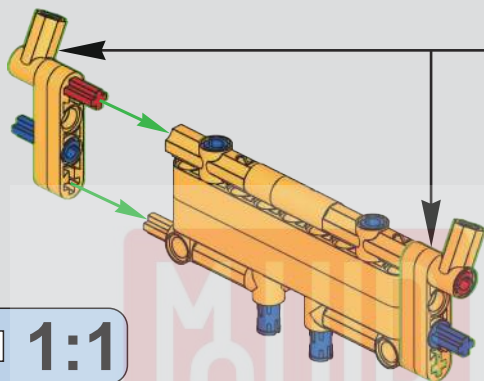

95

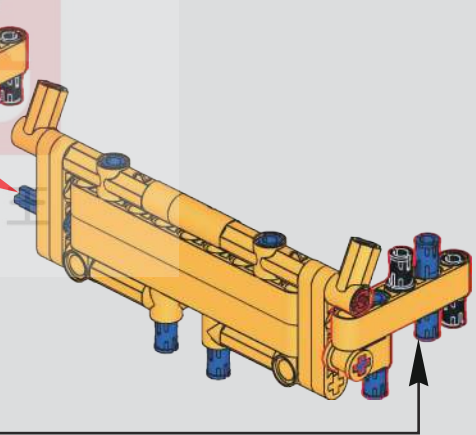
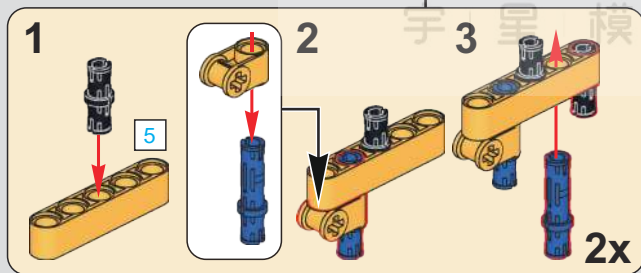

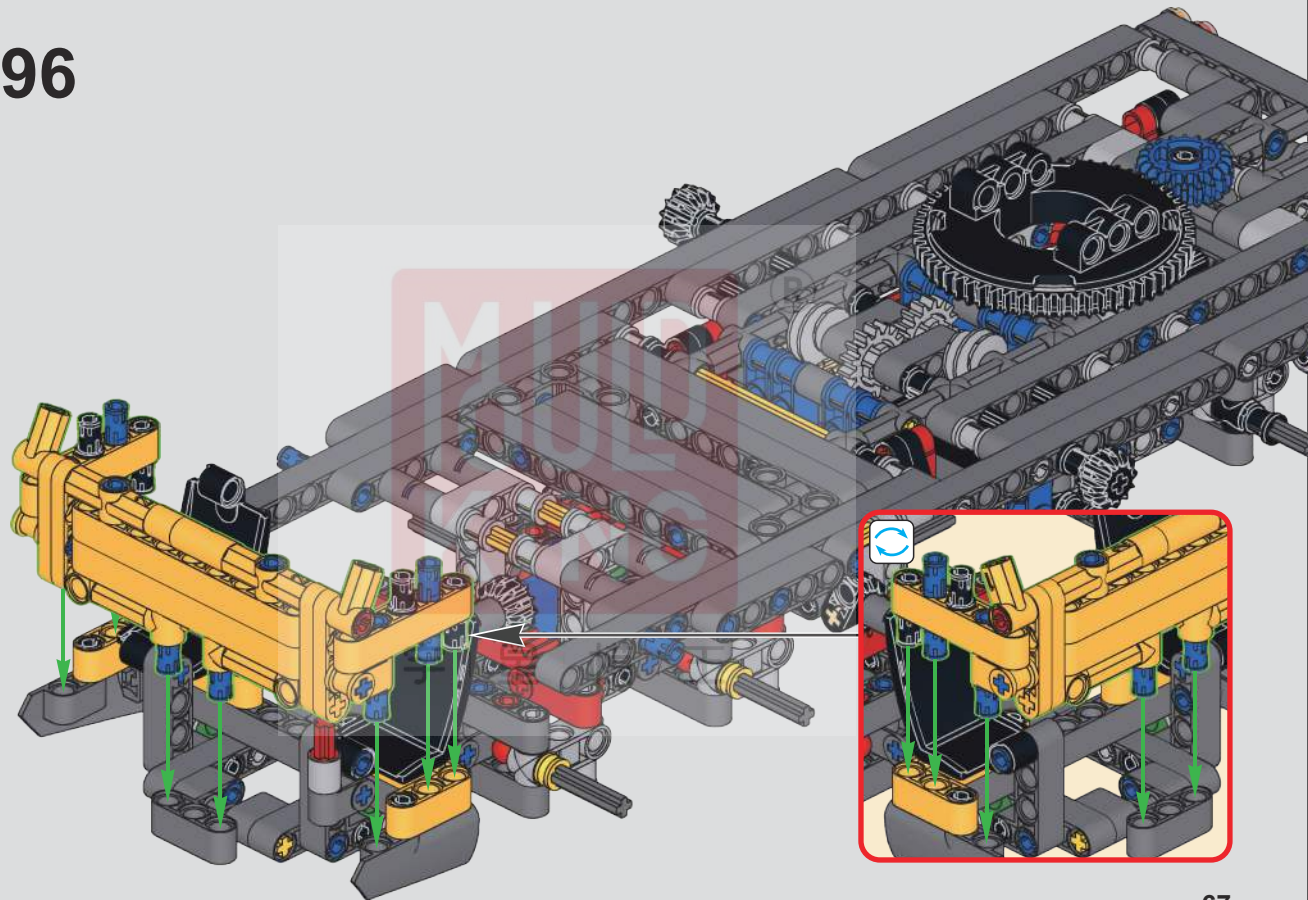

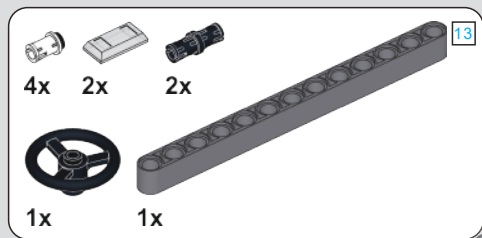

97

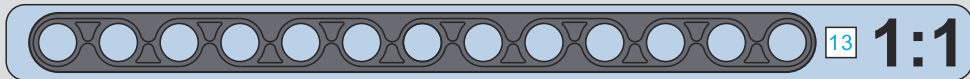
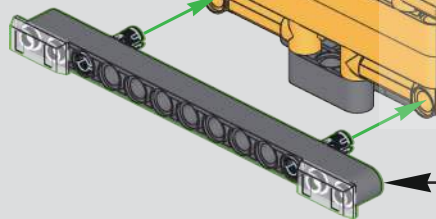
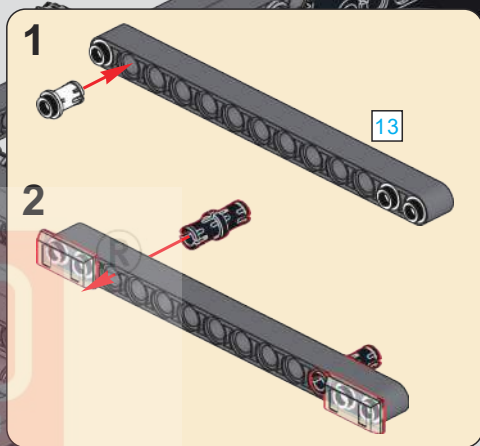

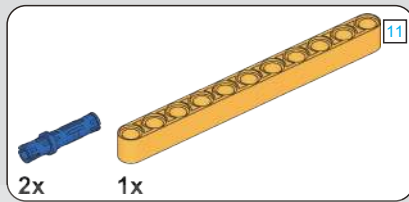
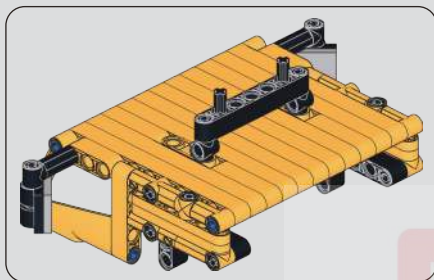

98

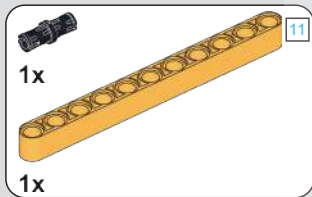
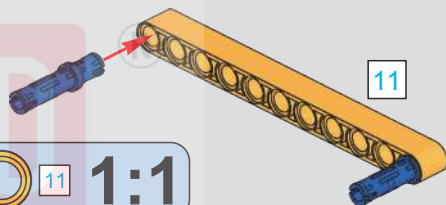

99

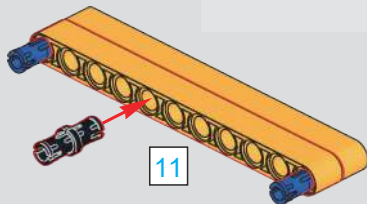

100

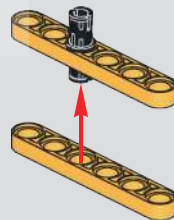

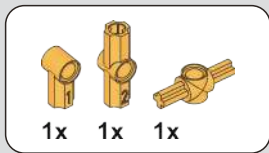

101

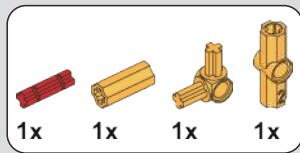
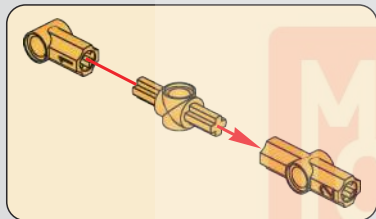

102

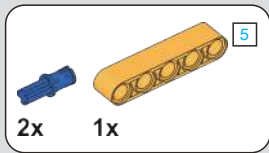
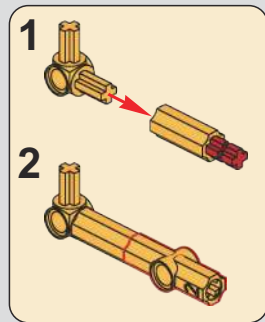
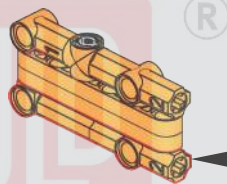

103

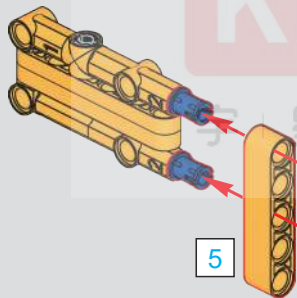

104

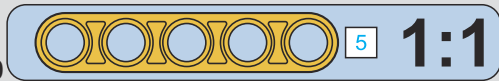
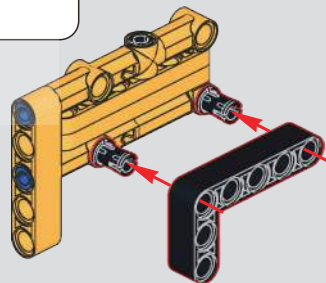

105

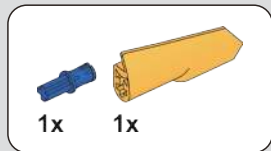
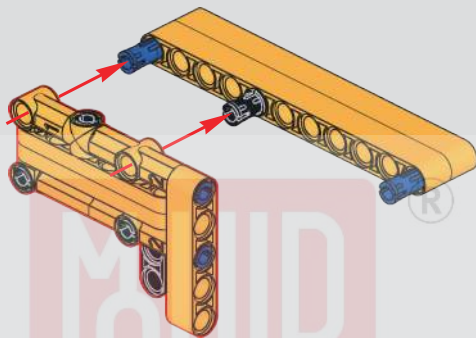

106

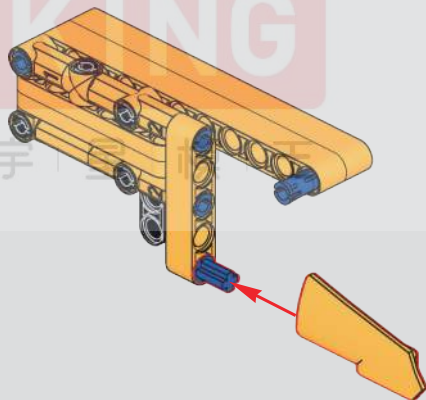

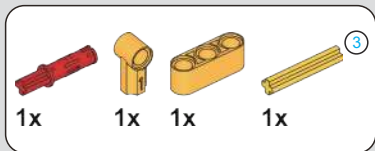

107

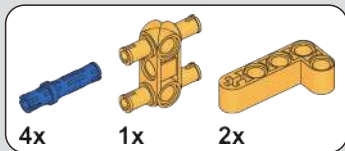
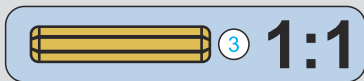

108

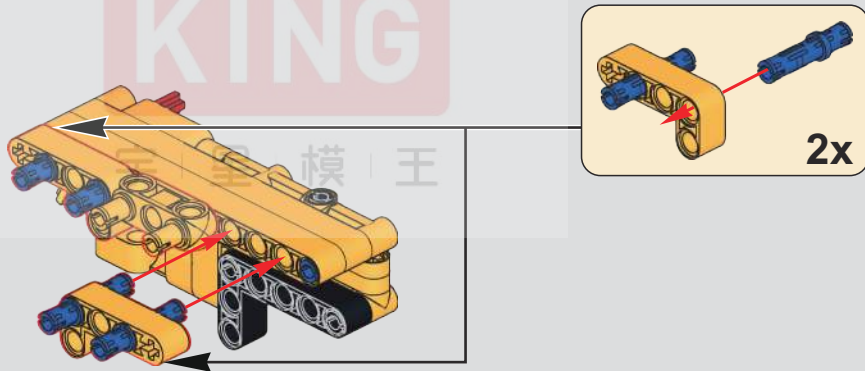
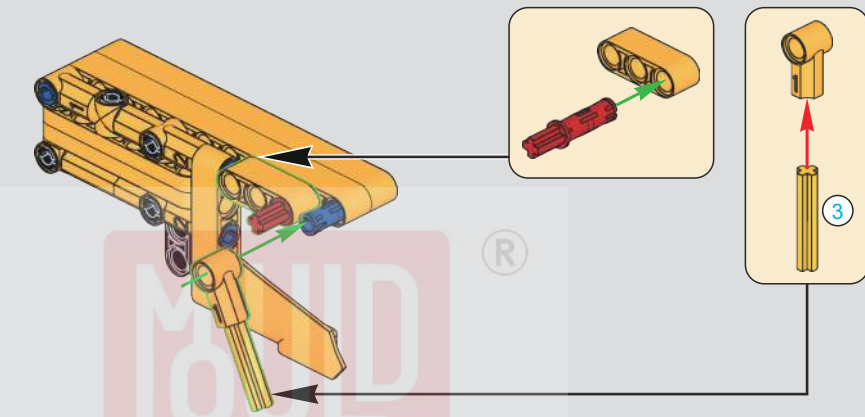

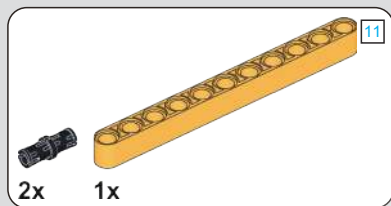

109

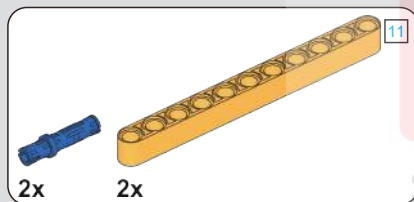
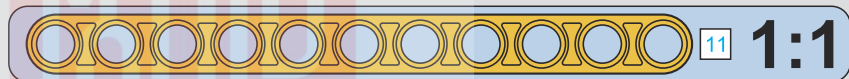
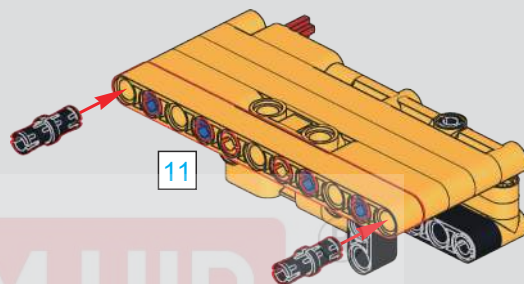

110

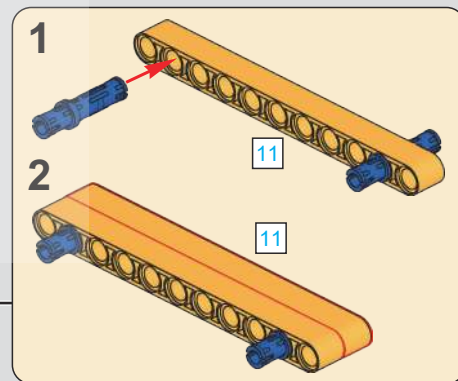
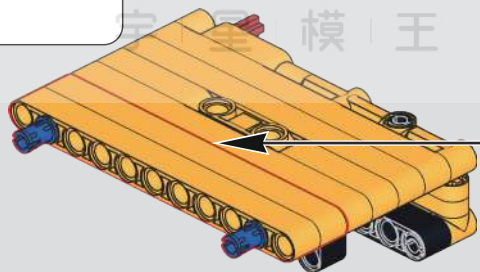

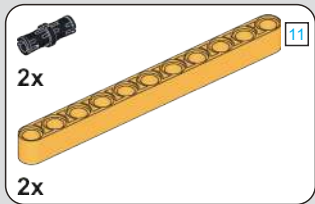

111

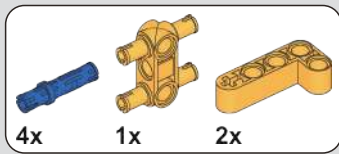
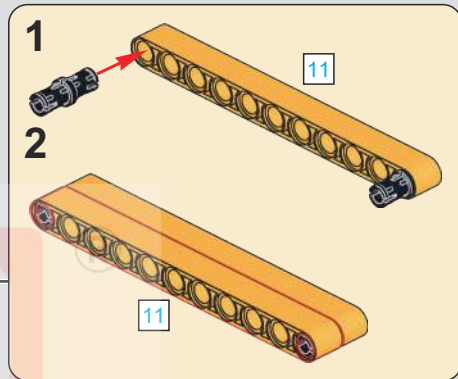
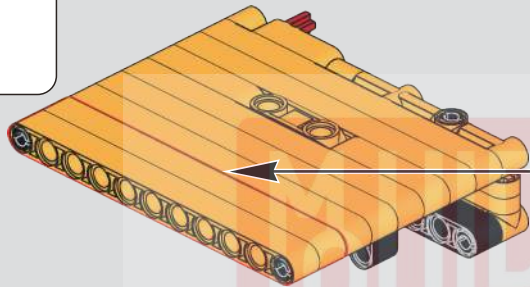

112

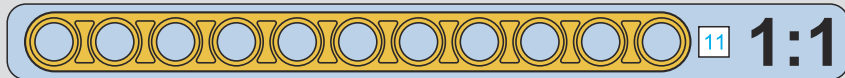
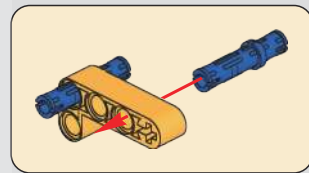
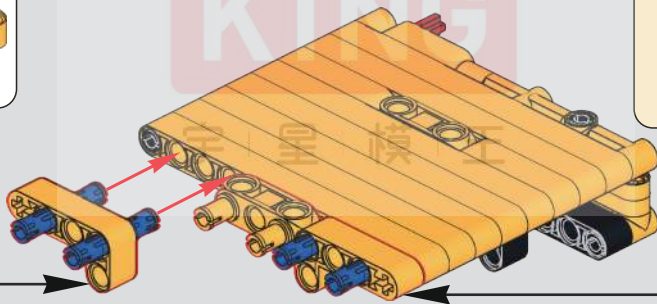
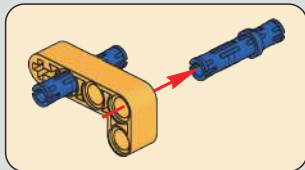

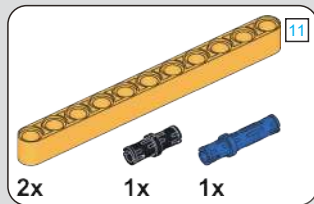

113

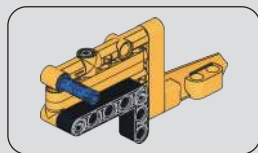
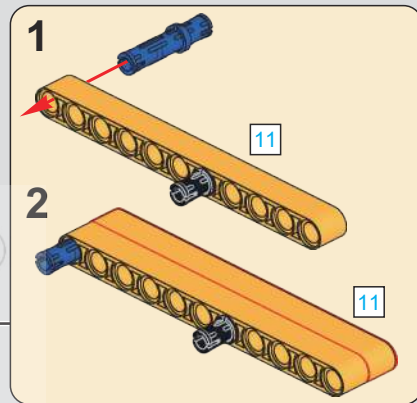
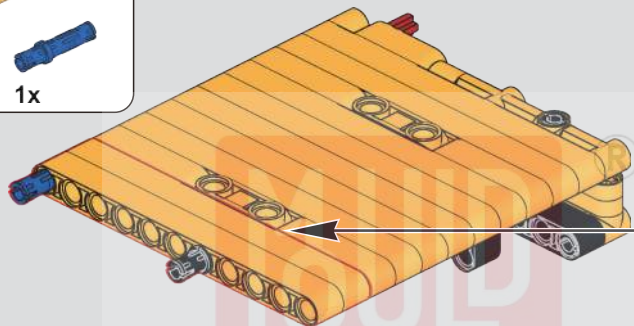

114

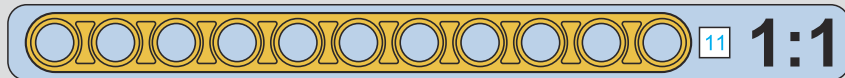
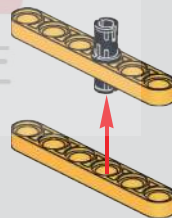

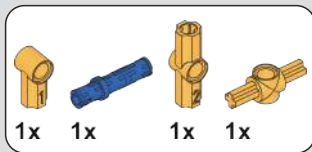

115

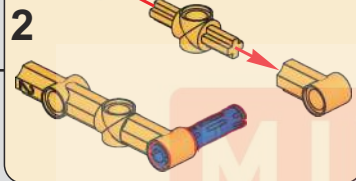
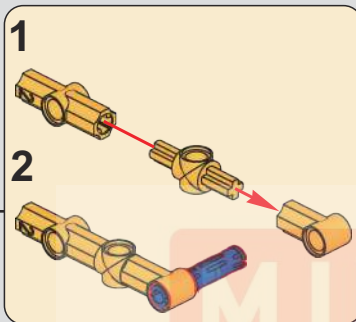
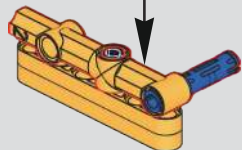

116

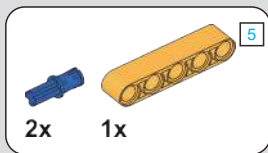
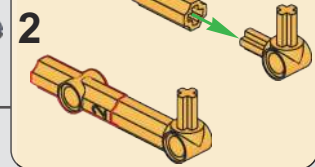
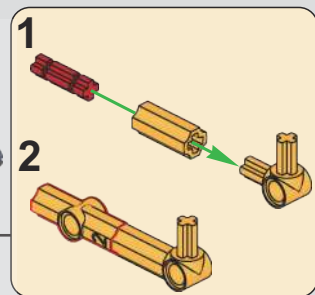
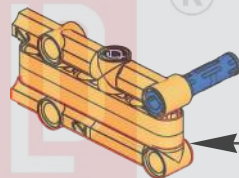

117

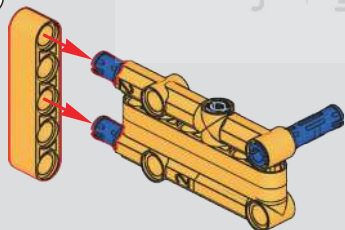

118

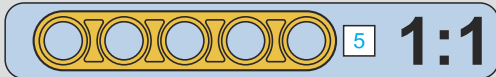
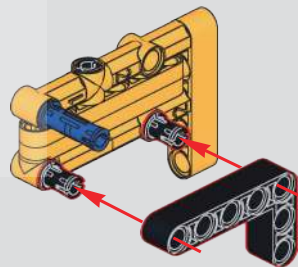

120

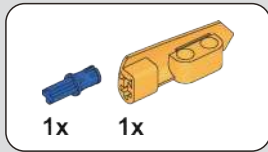

119

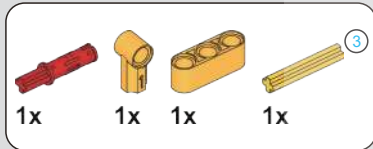
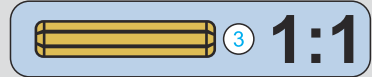
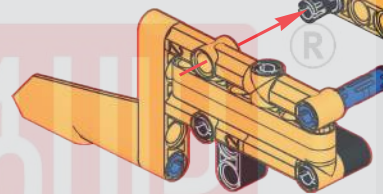
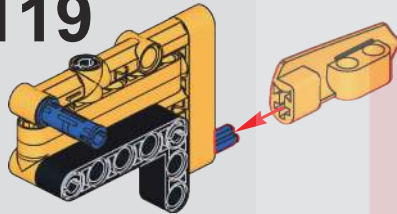

121

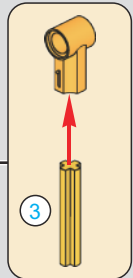
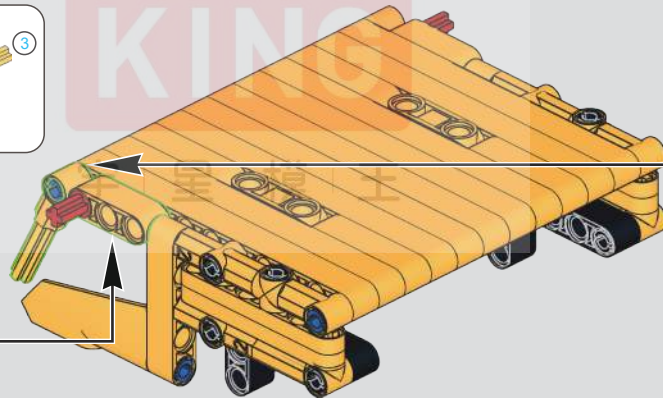
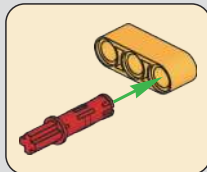

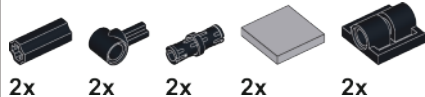

122

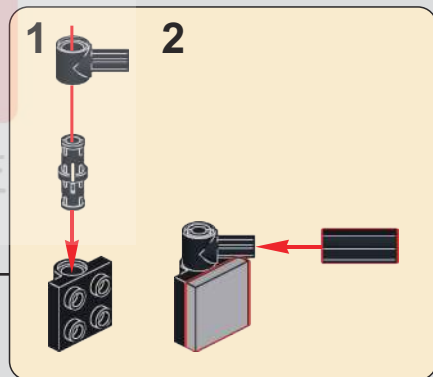
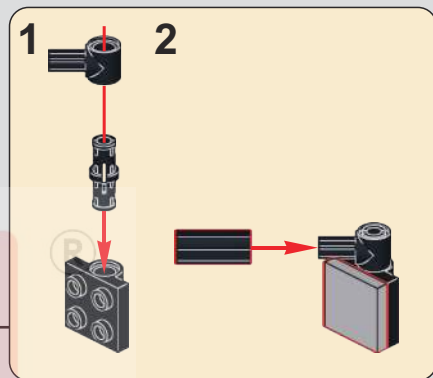
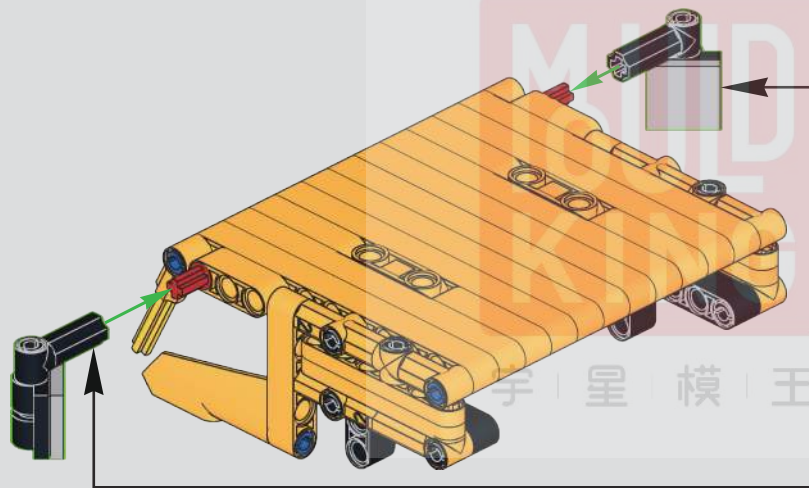

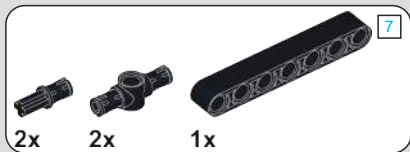

123

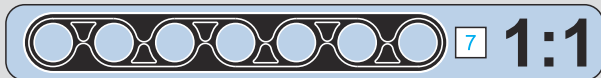
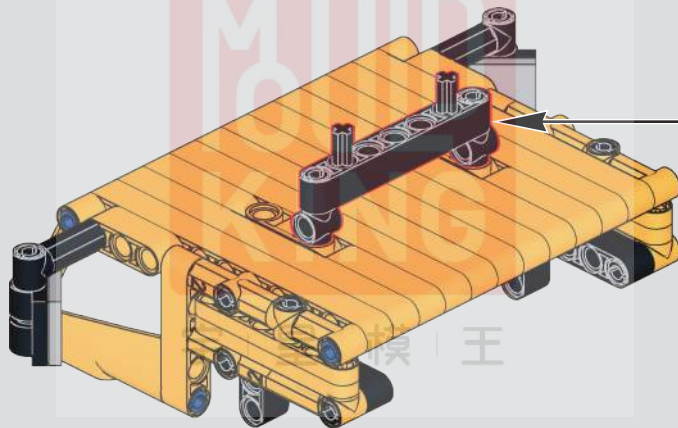
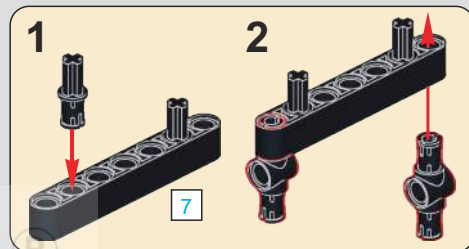

124

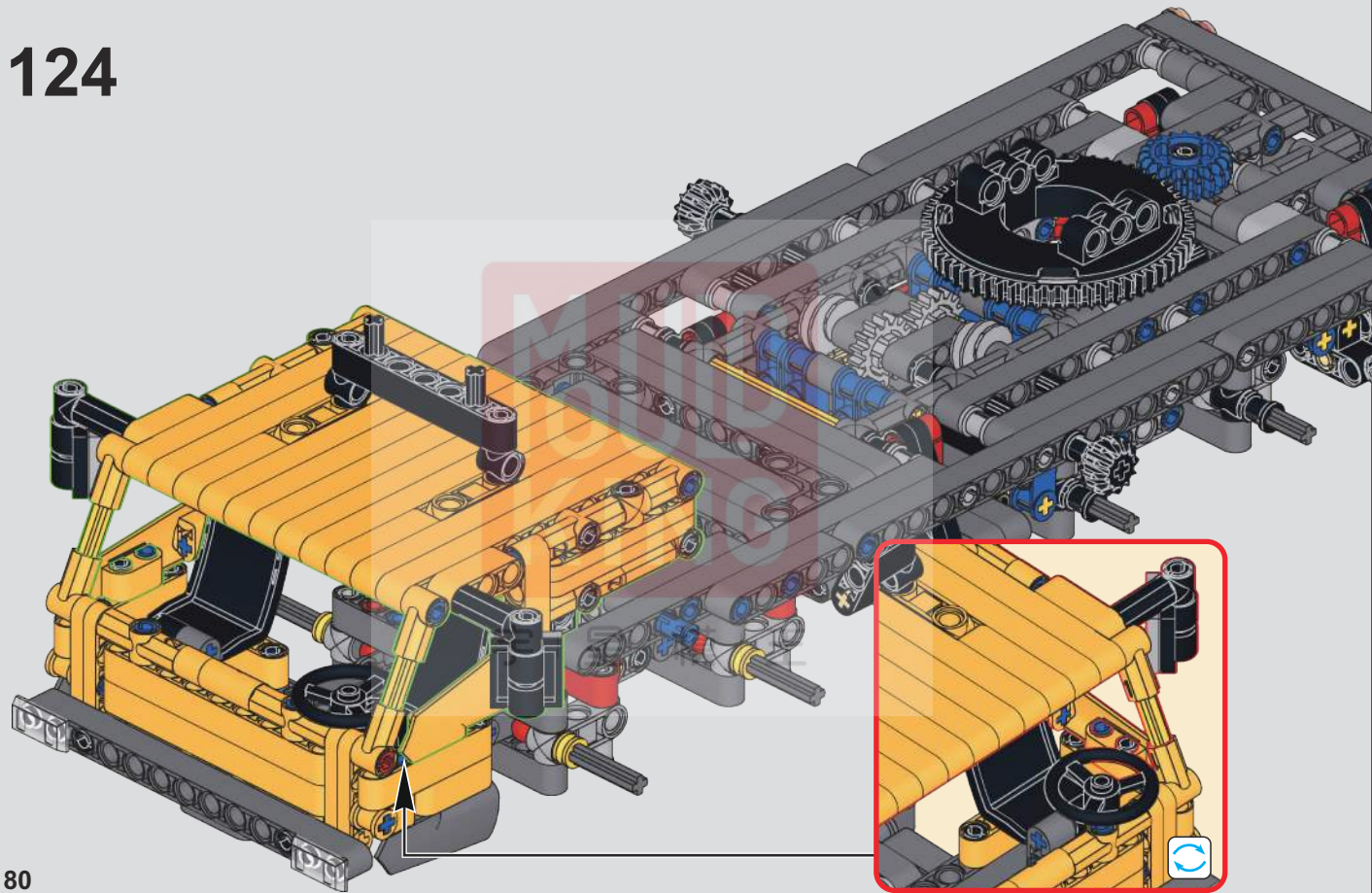

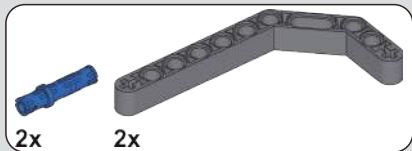

125

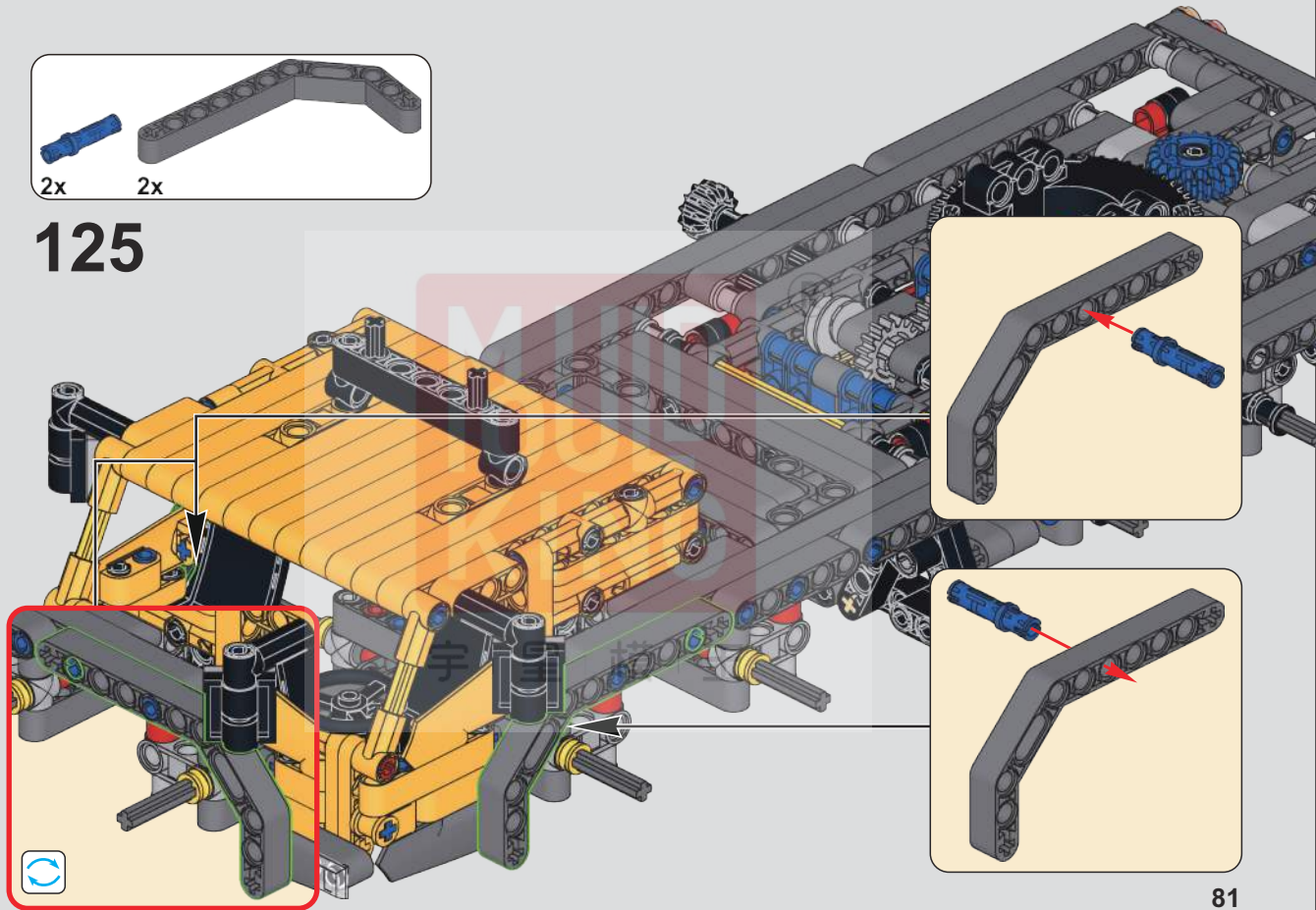

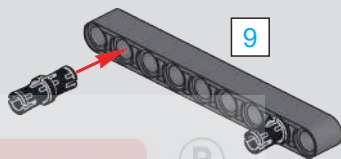
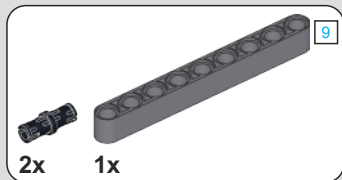
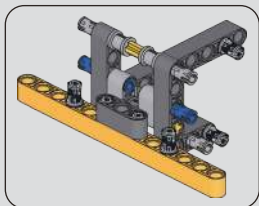

126

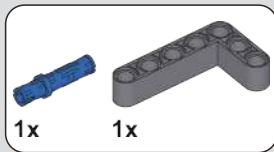

127

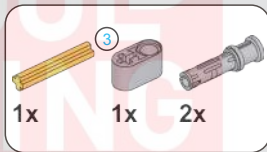
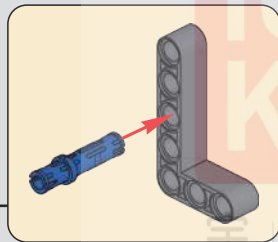

128

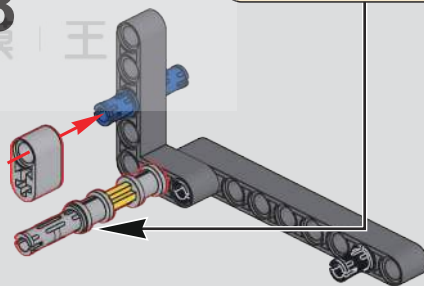
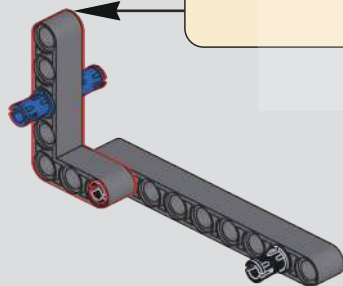
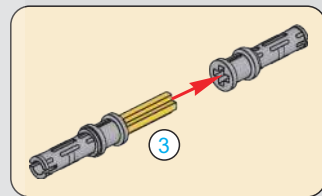

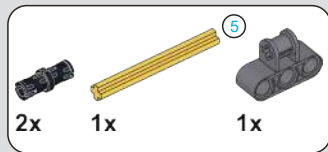

129

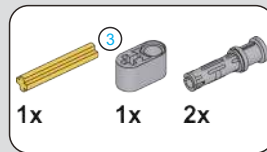
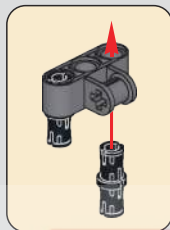
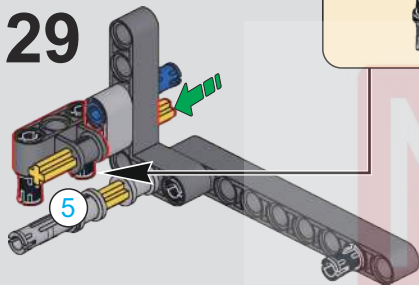

130

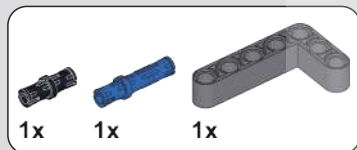
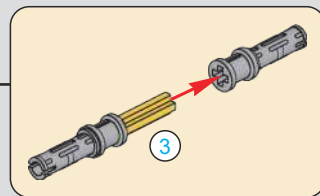
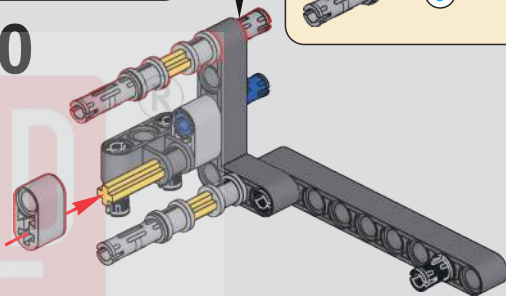

131

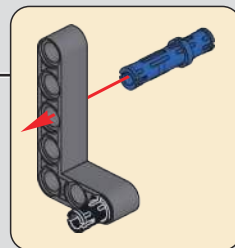
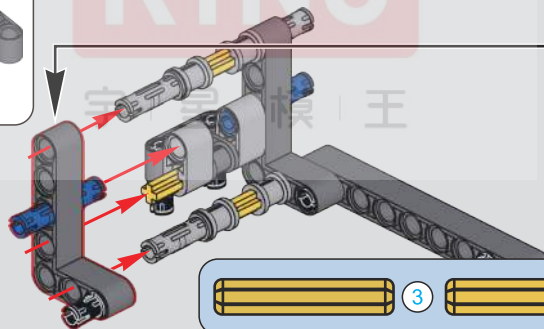

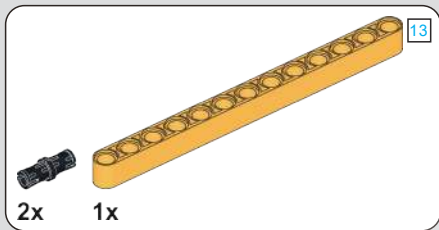

132

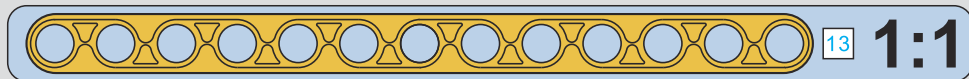
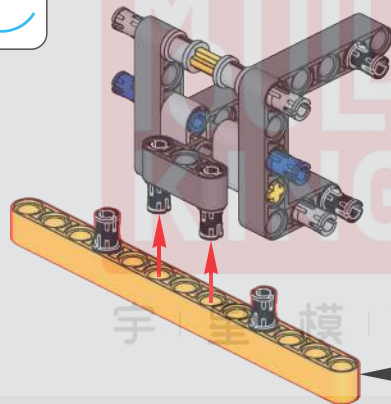
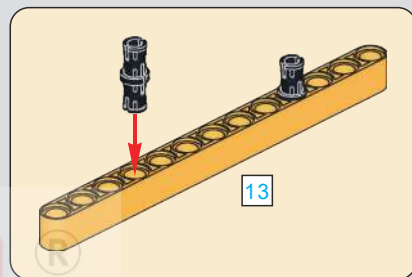

133

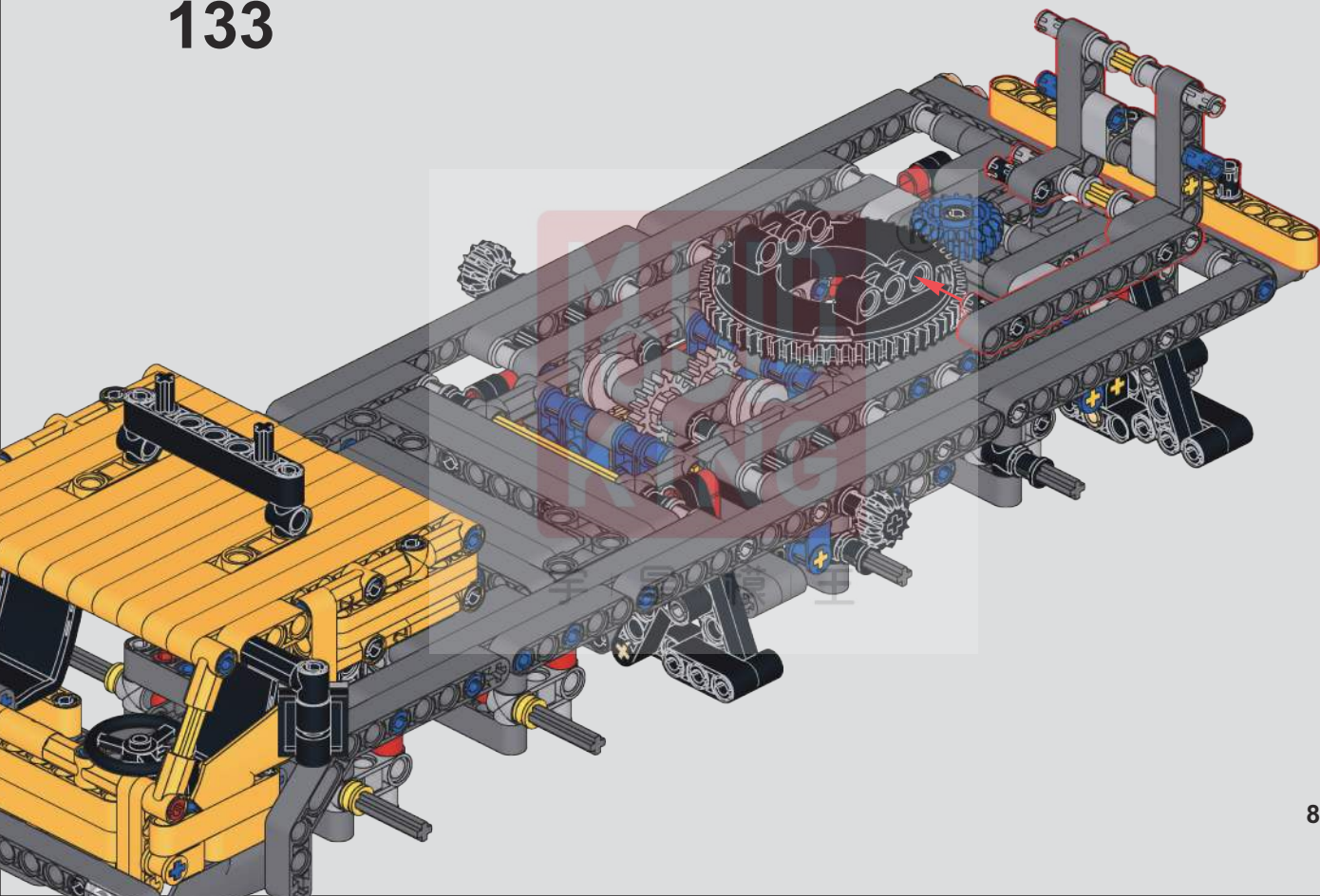

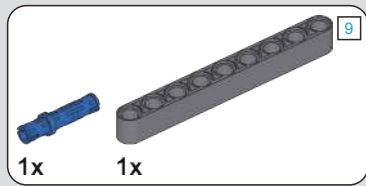

134

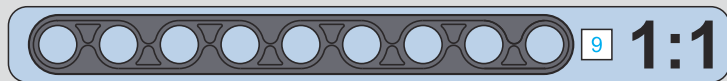
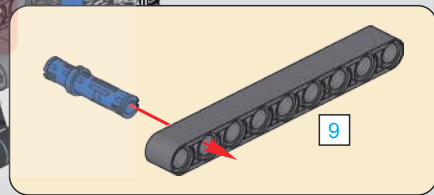
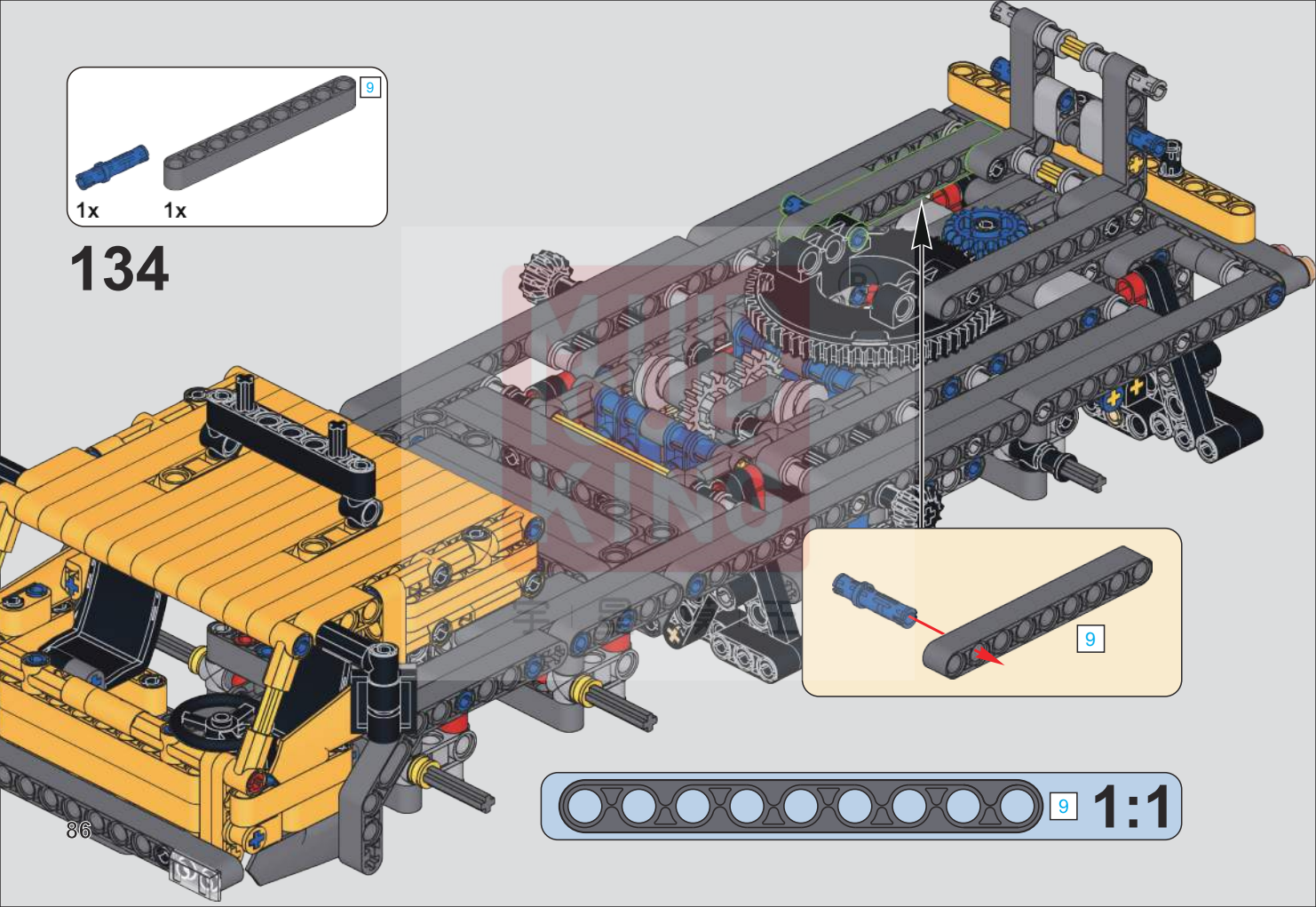

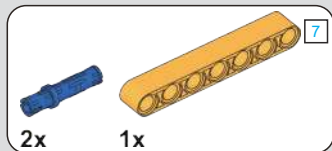
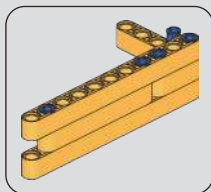

135

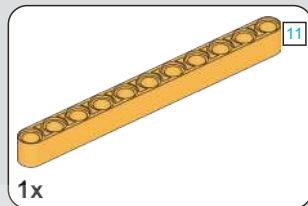
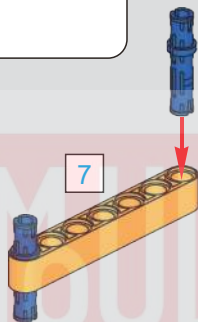

136

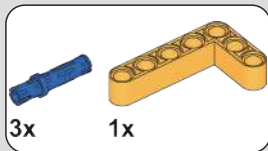
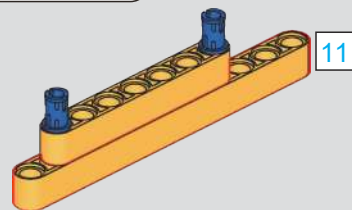

137

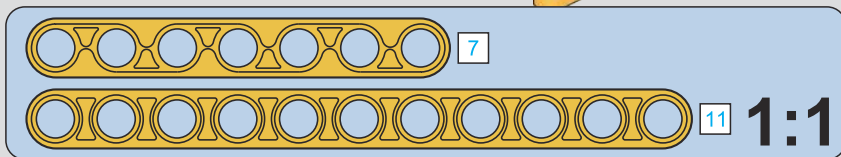
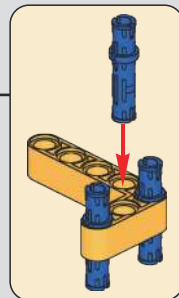
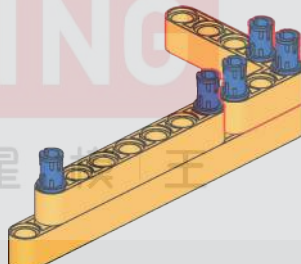

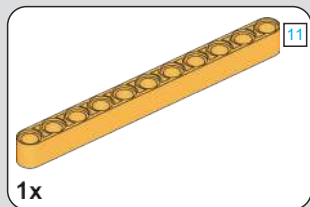

138

139

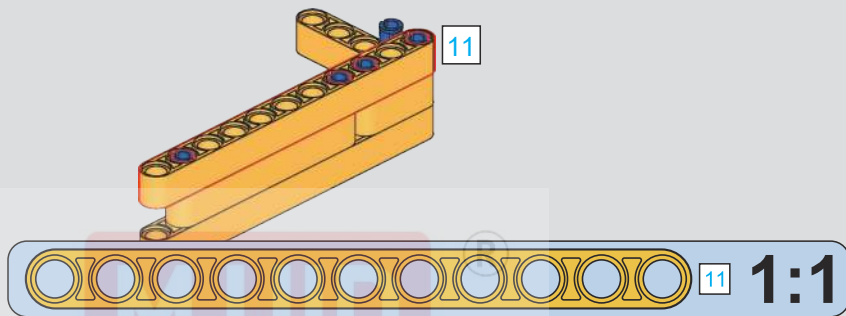

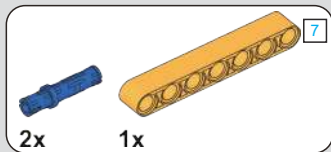
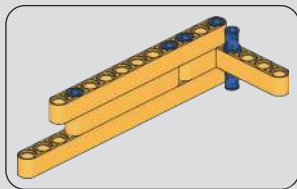

140

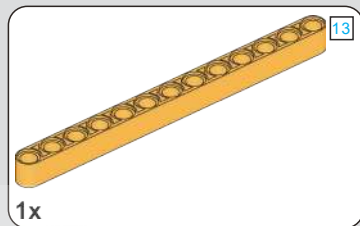
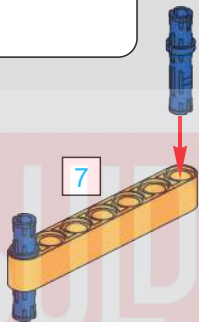

141

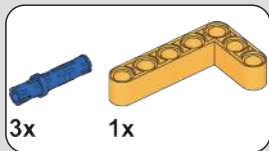
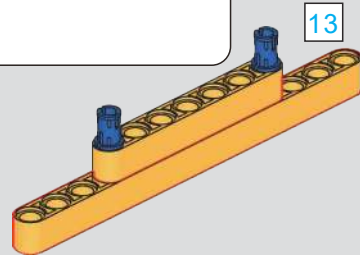

142

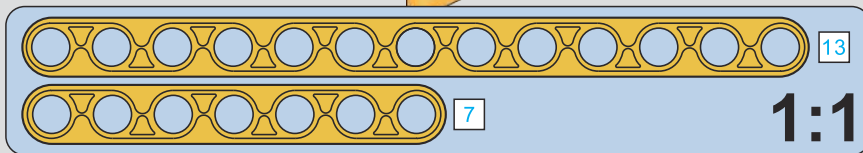
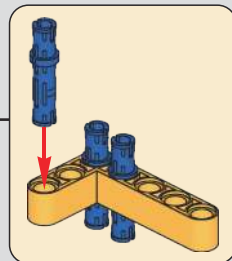
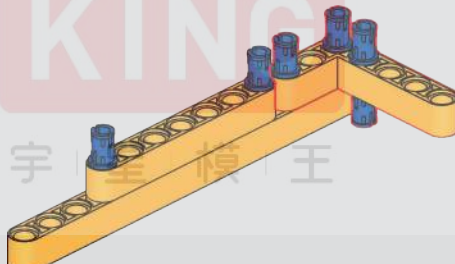

1:1

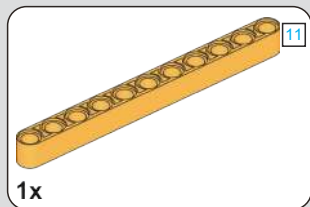

1x

143

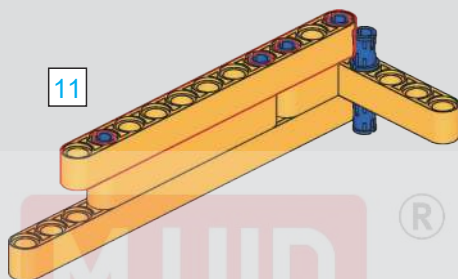

144

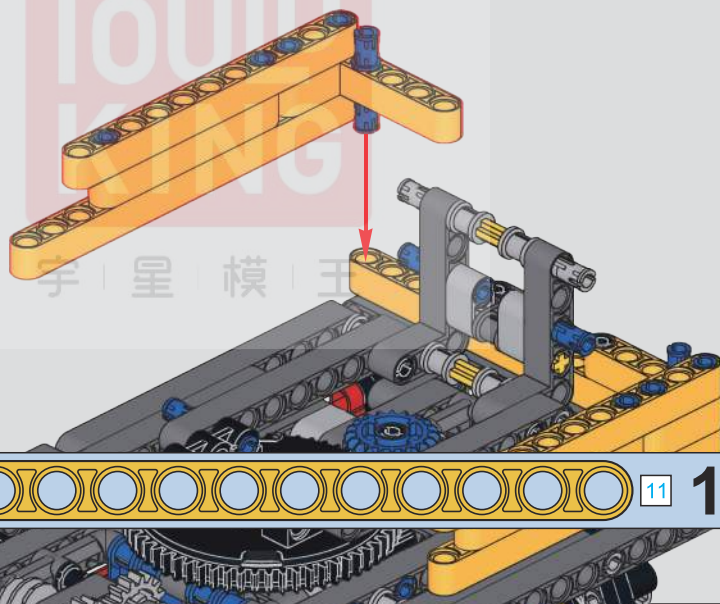

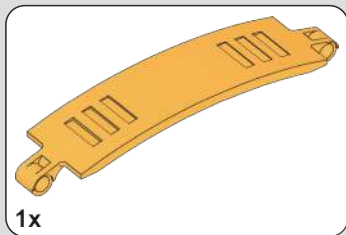

145

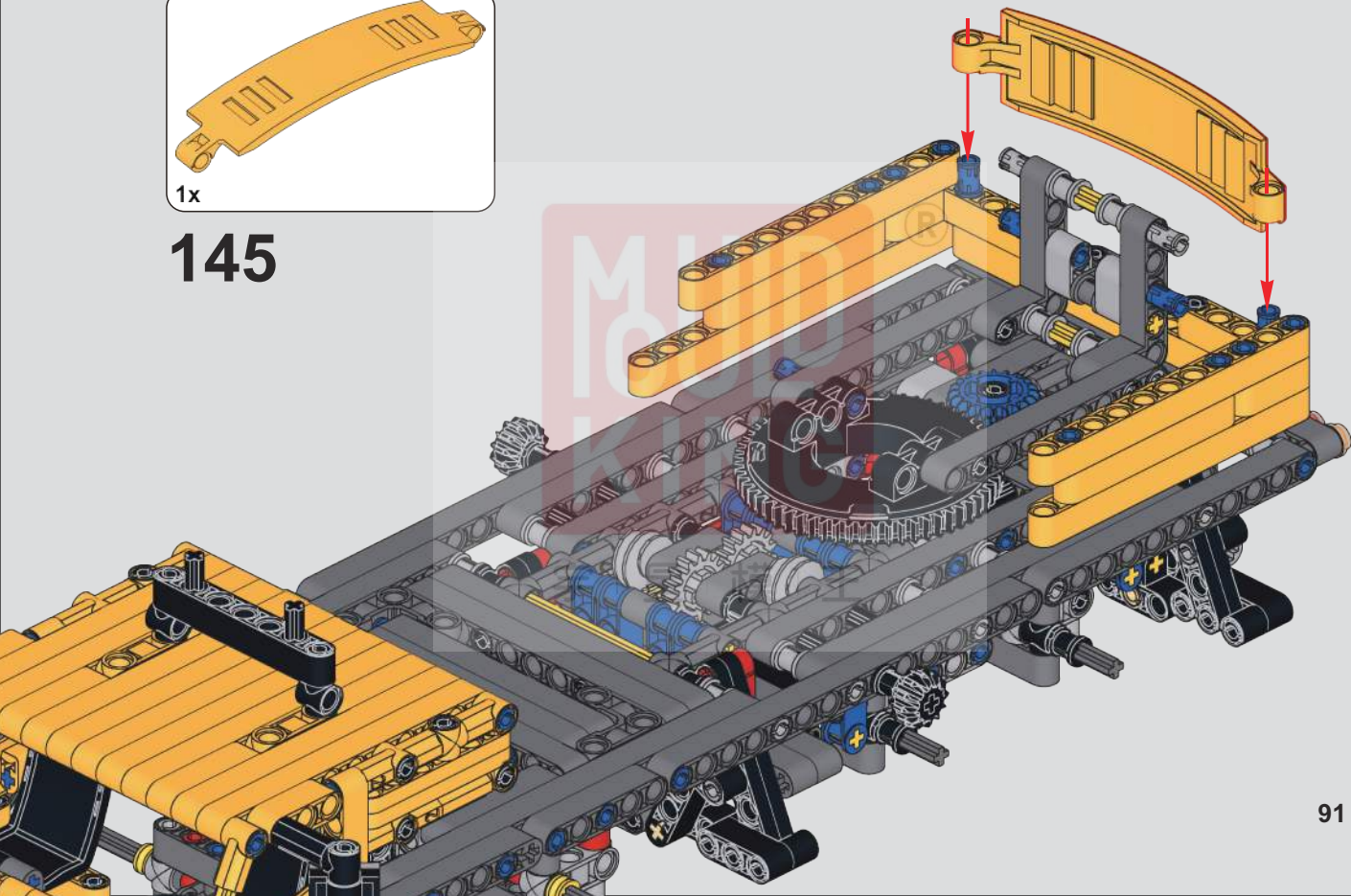

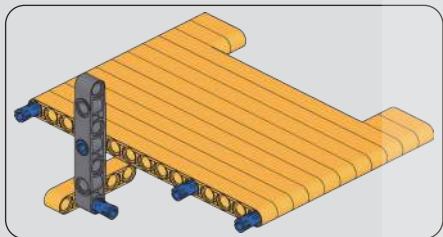

146

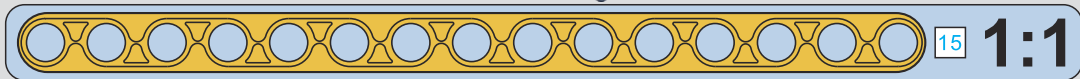
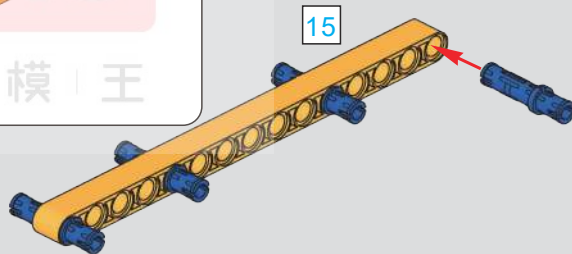

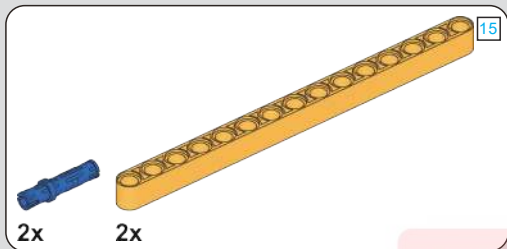

147

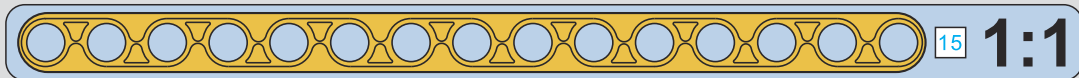
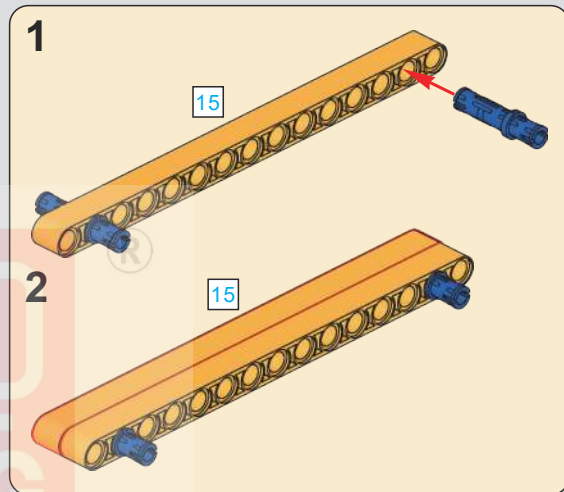
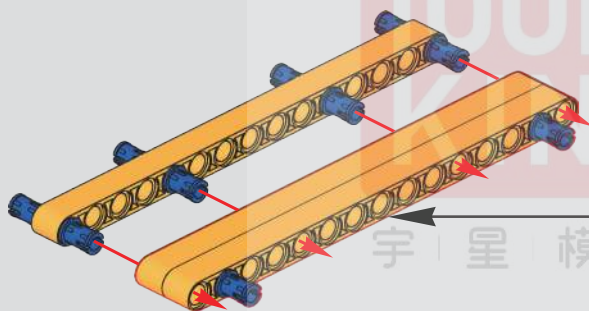

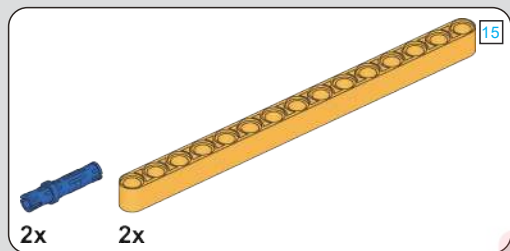

148

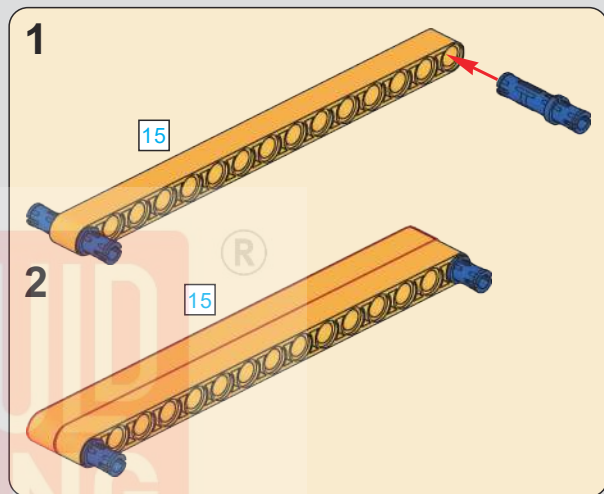
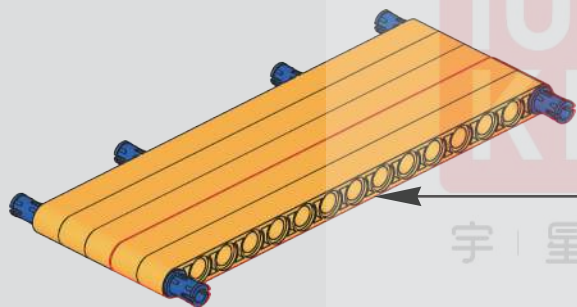

宇 | 星 | 模 | 王



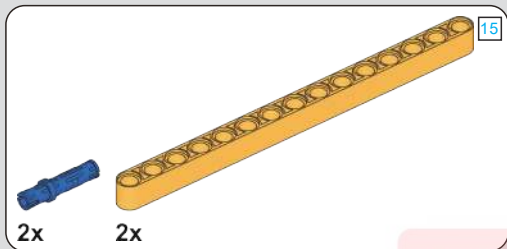

149

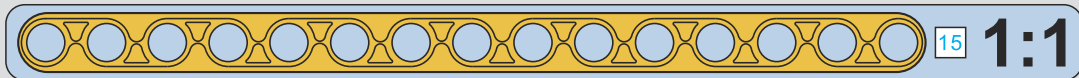
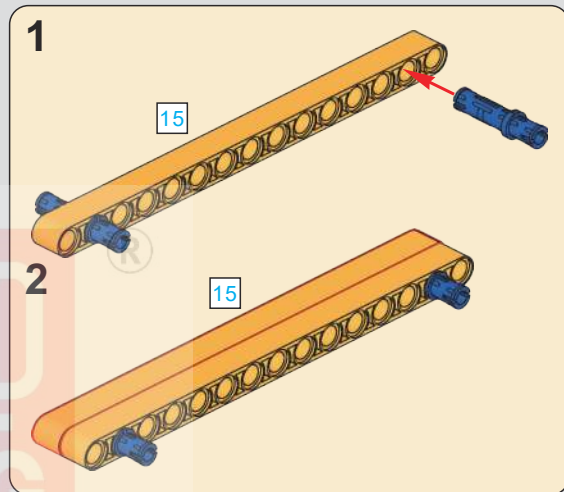
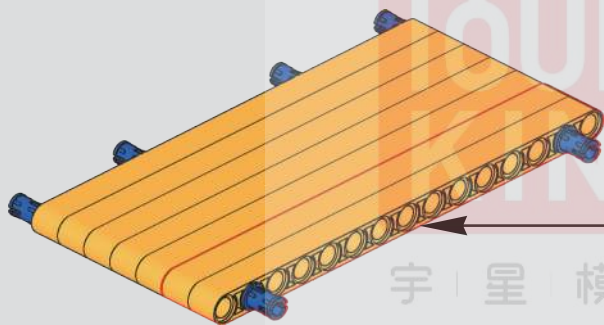

宇 | 星 | 模 | 王

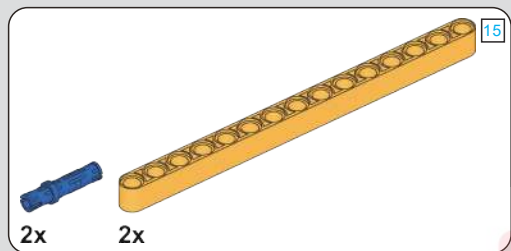

150

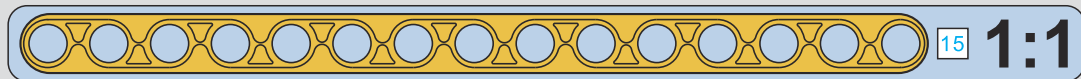
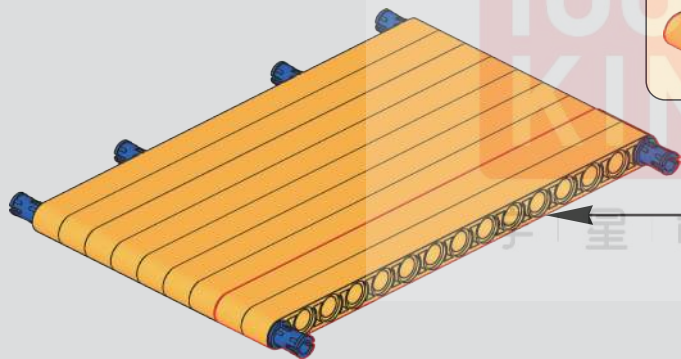
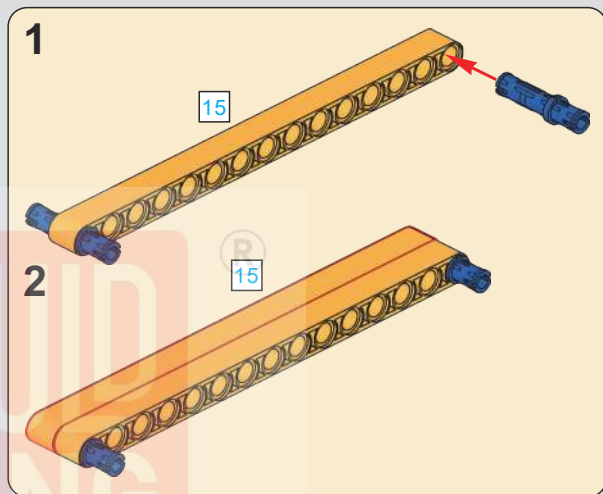

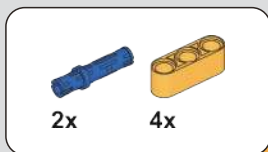

151

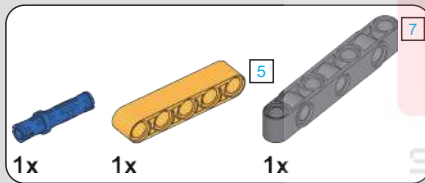
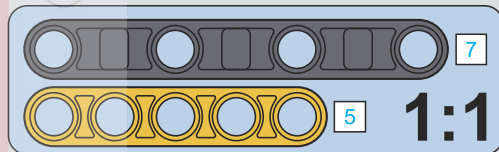
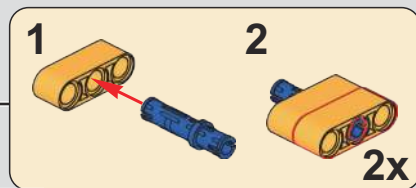
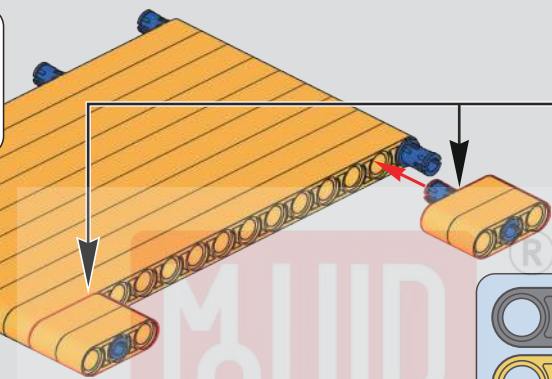

152

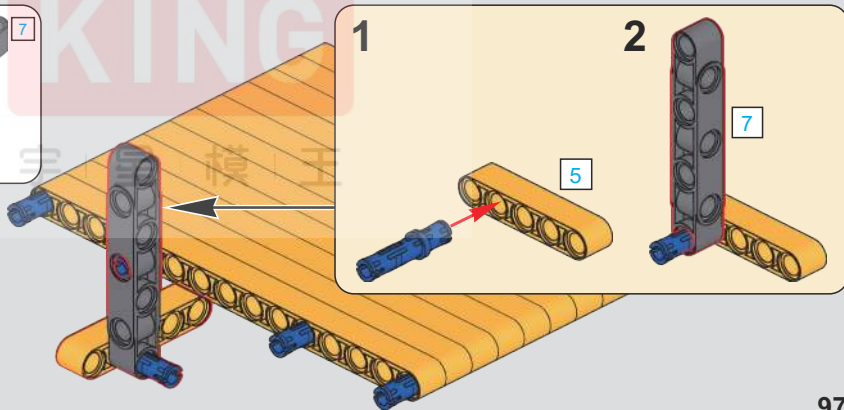

153

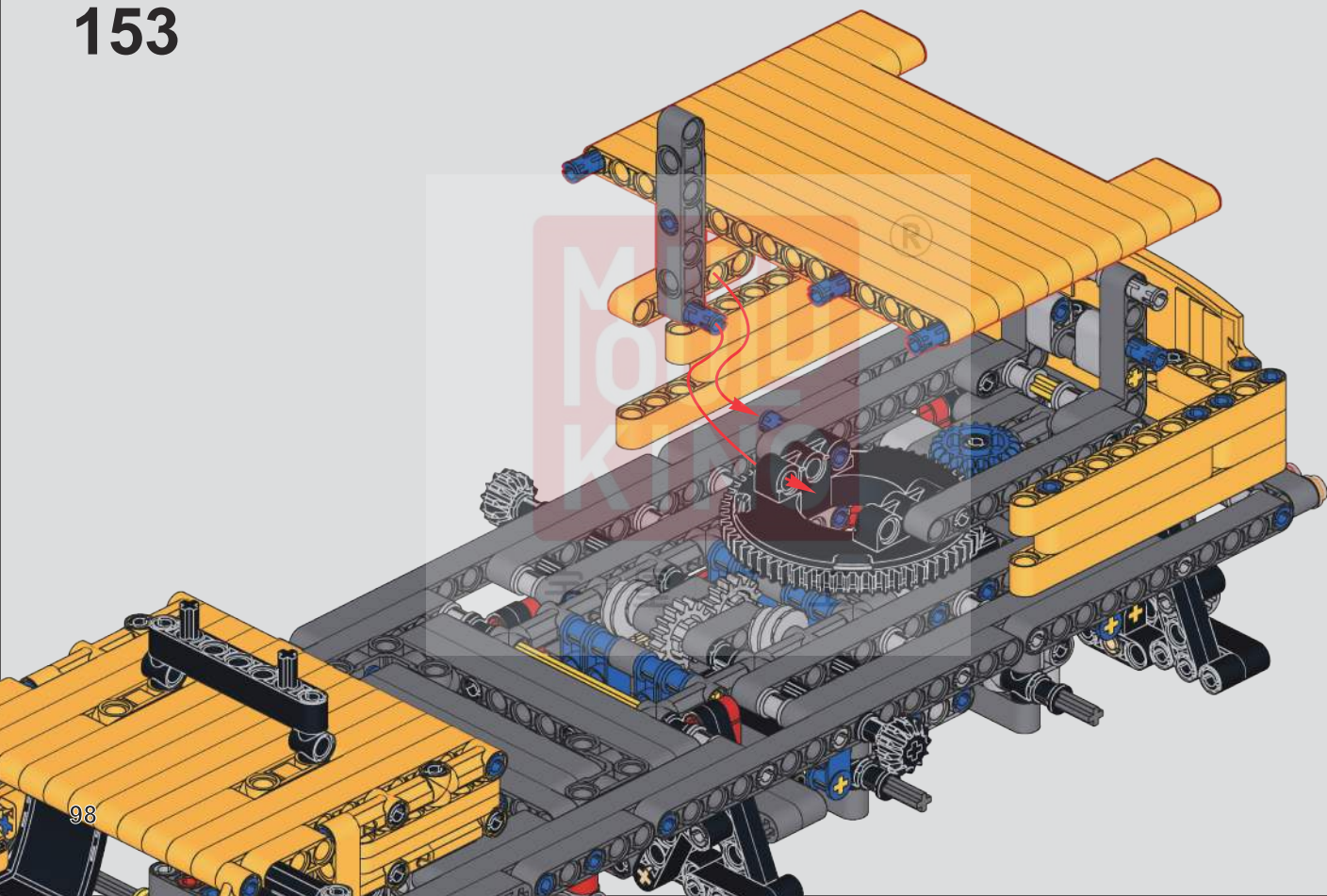

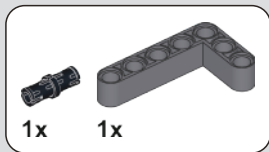

154

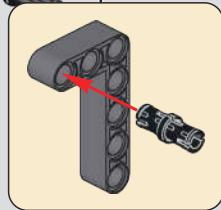
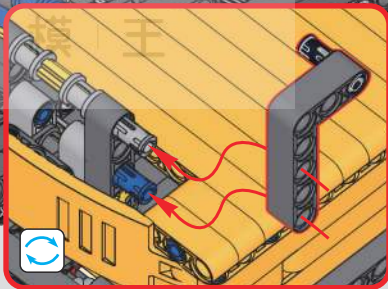
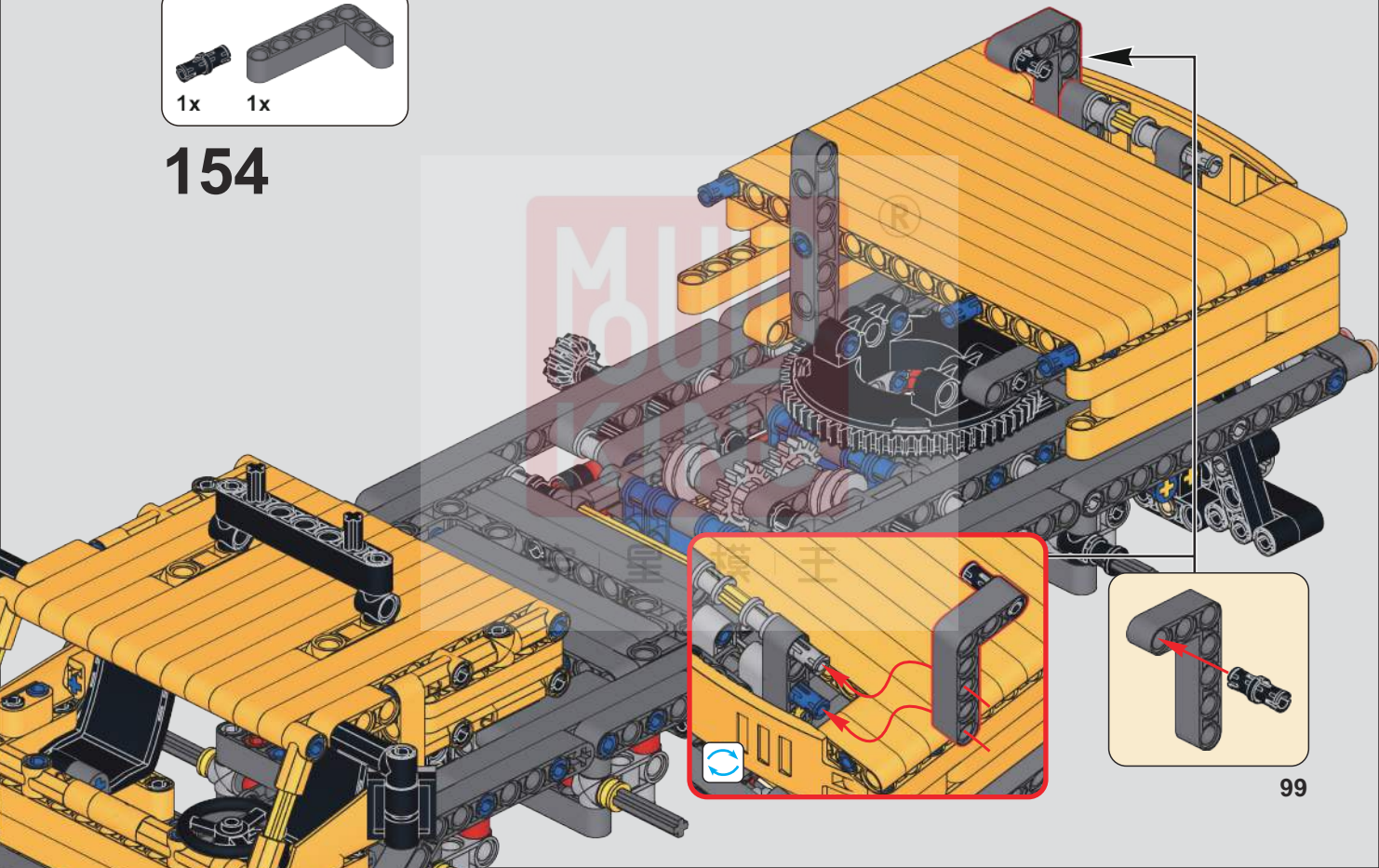

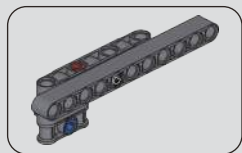

155

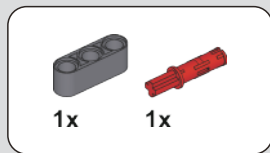

156

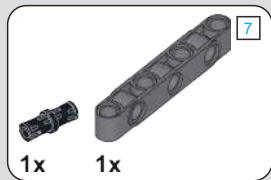
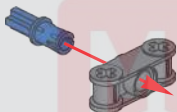
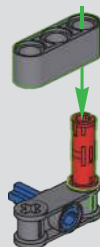

157

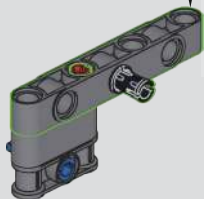
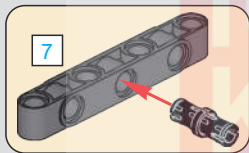

158

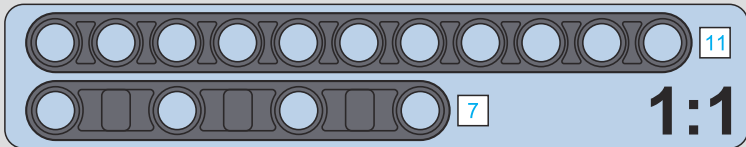
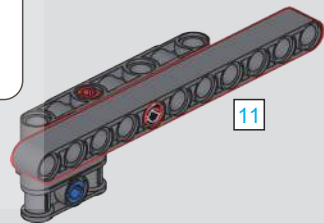

159

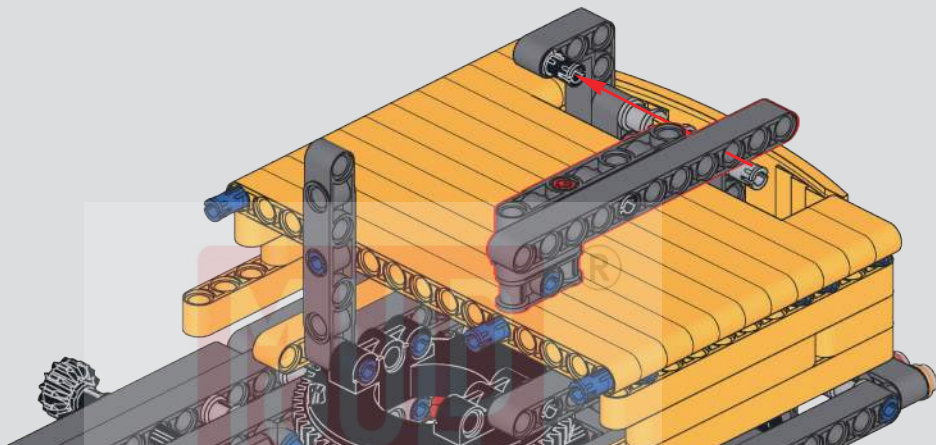

160

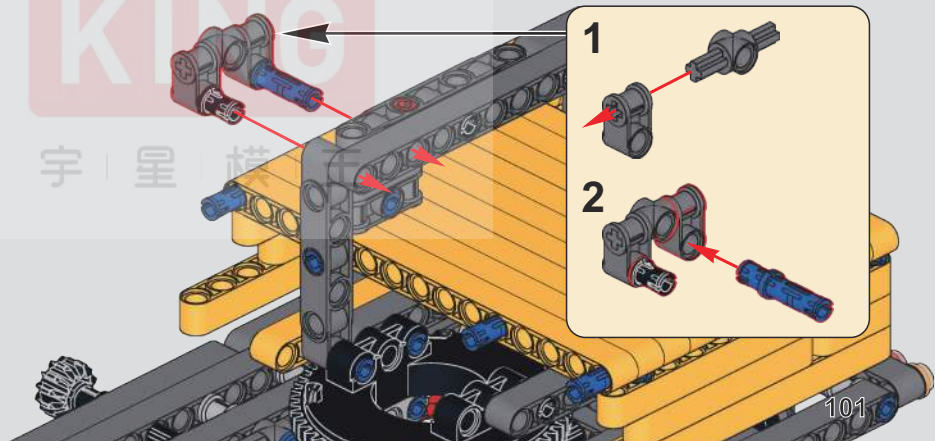

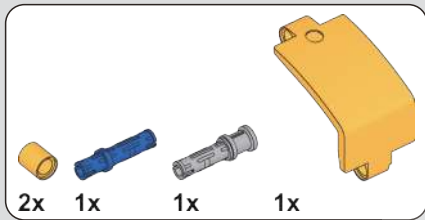

161

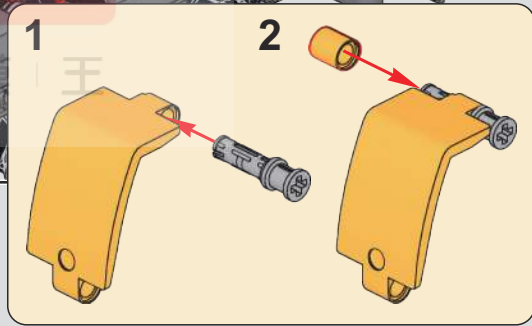
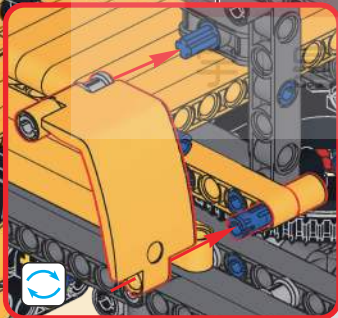
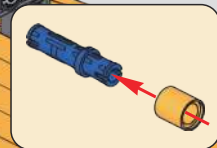
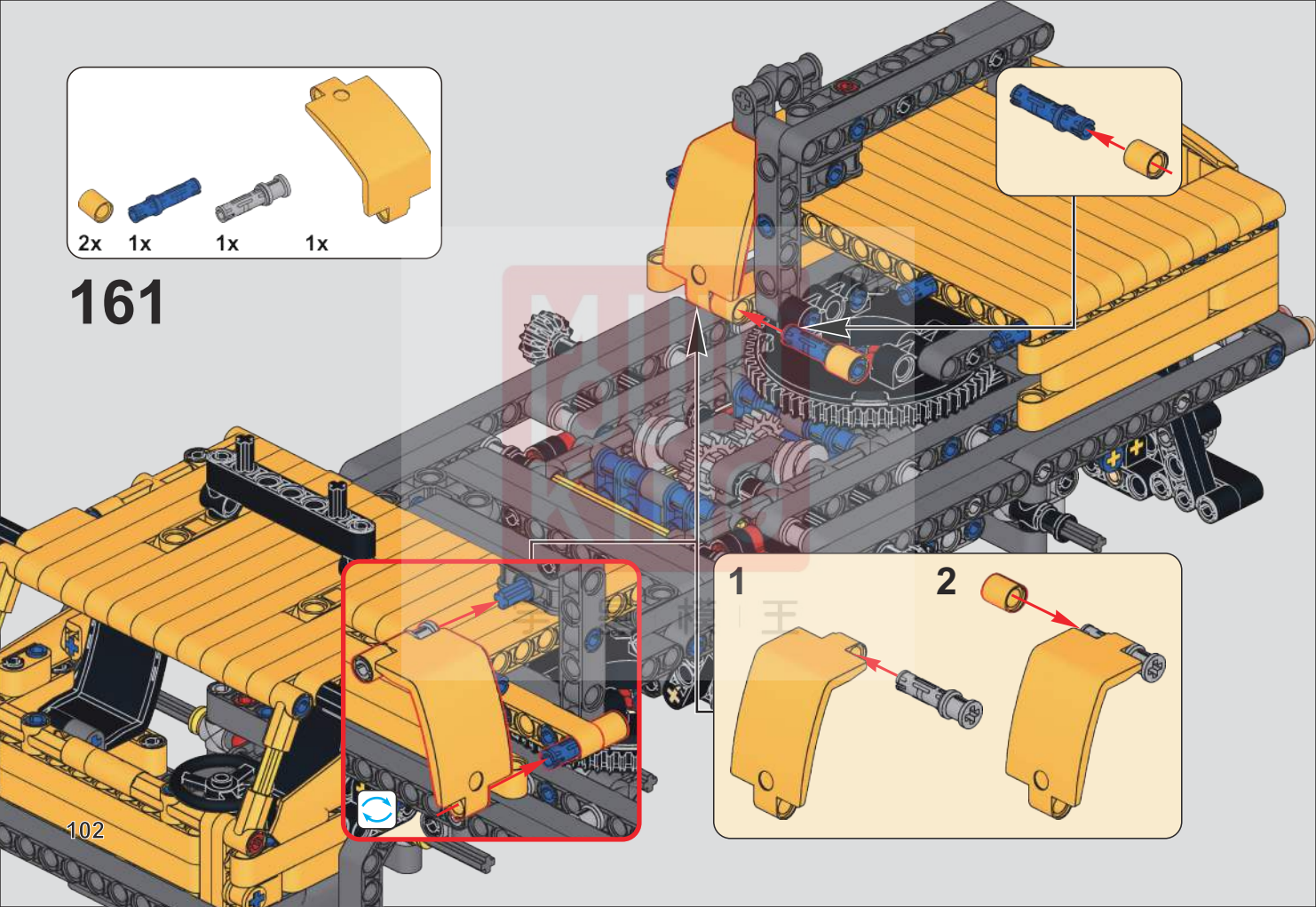

1x 2x

162

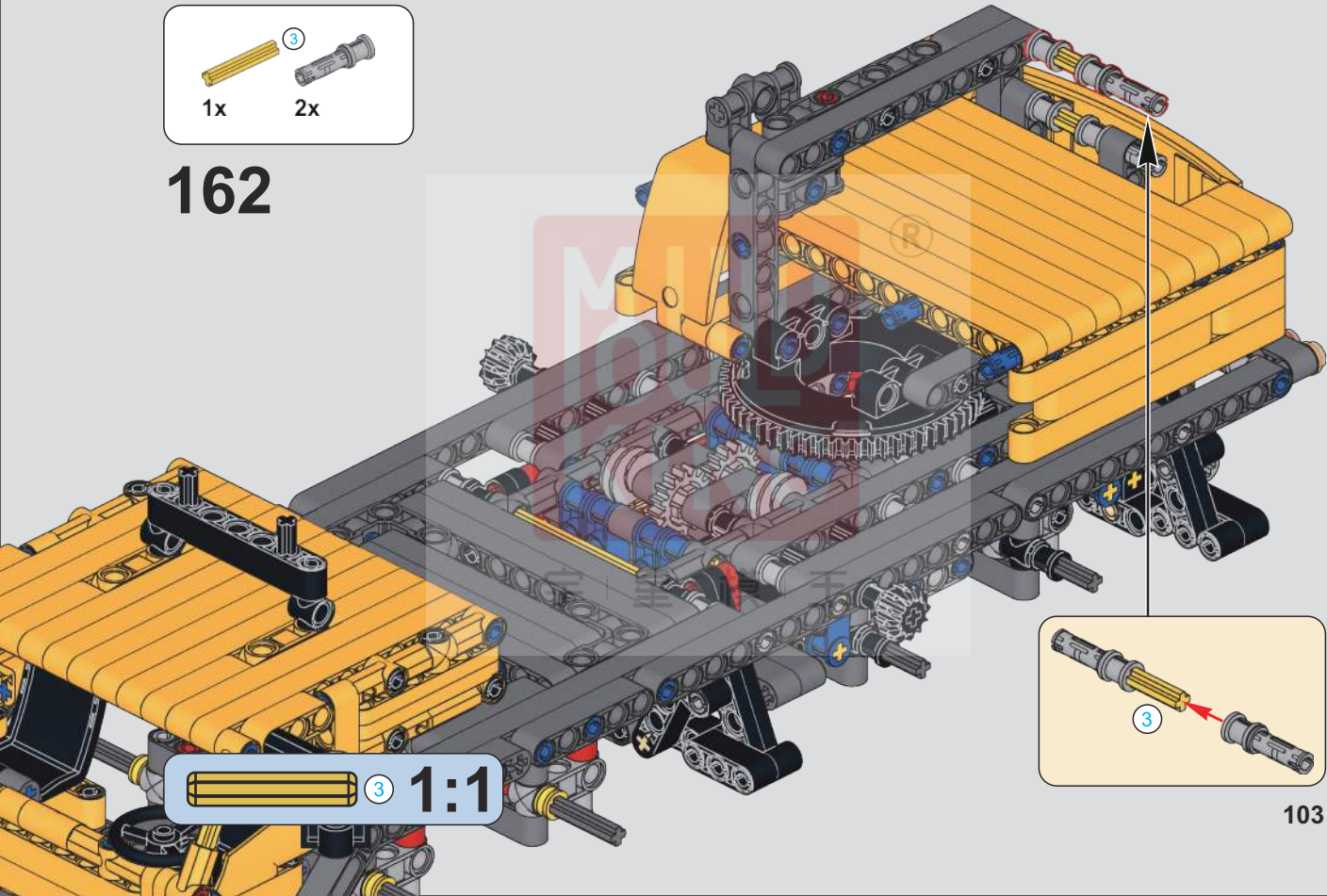

1:1

3

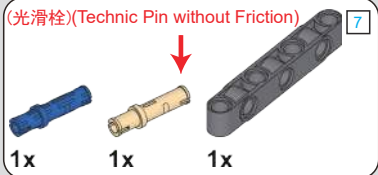
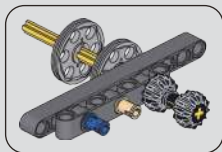

163

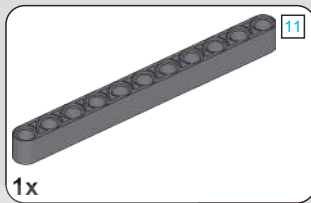
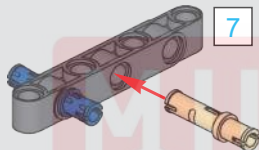

164[®]

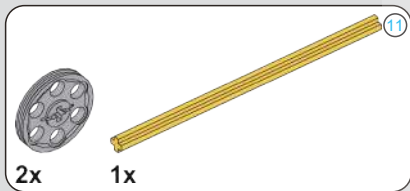
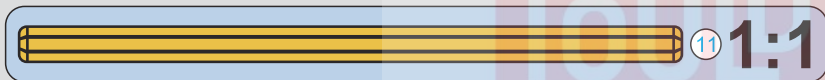
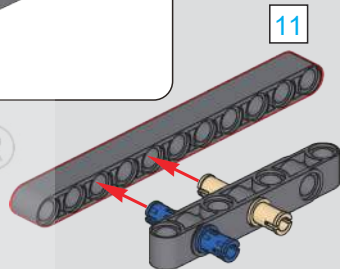

165

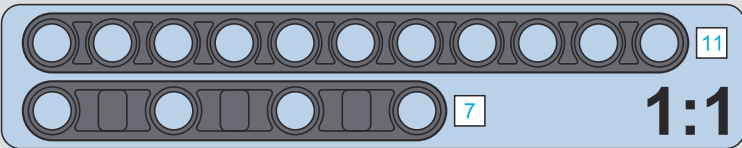
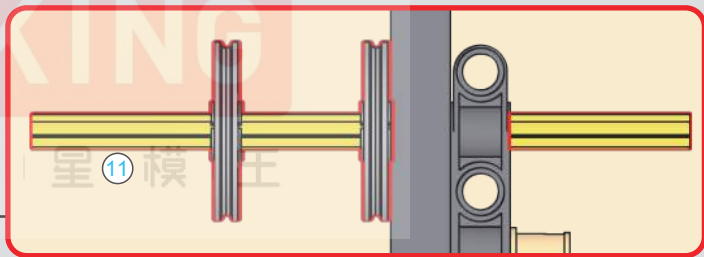
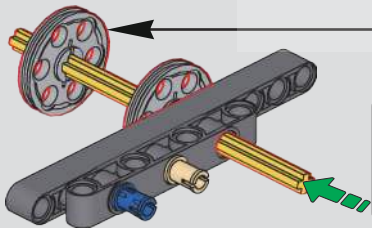



166

167

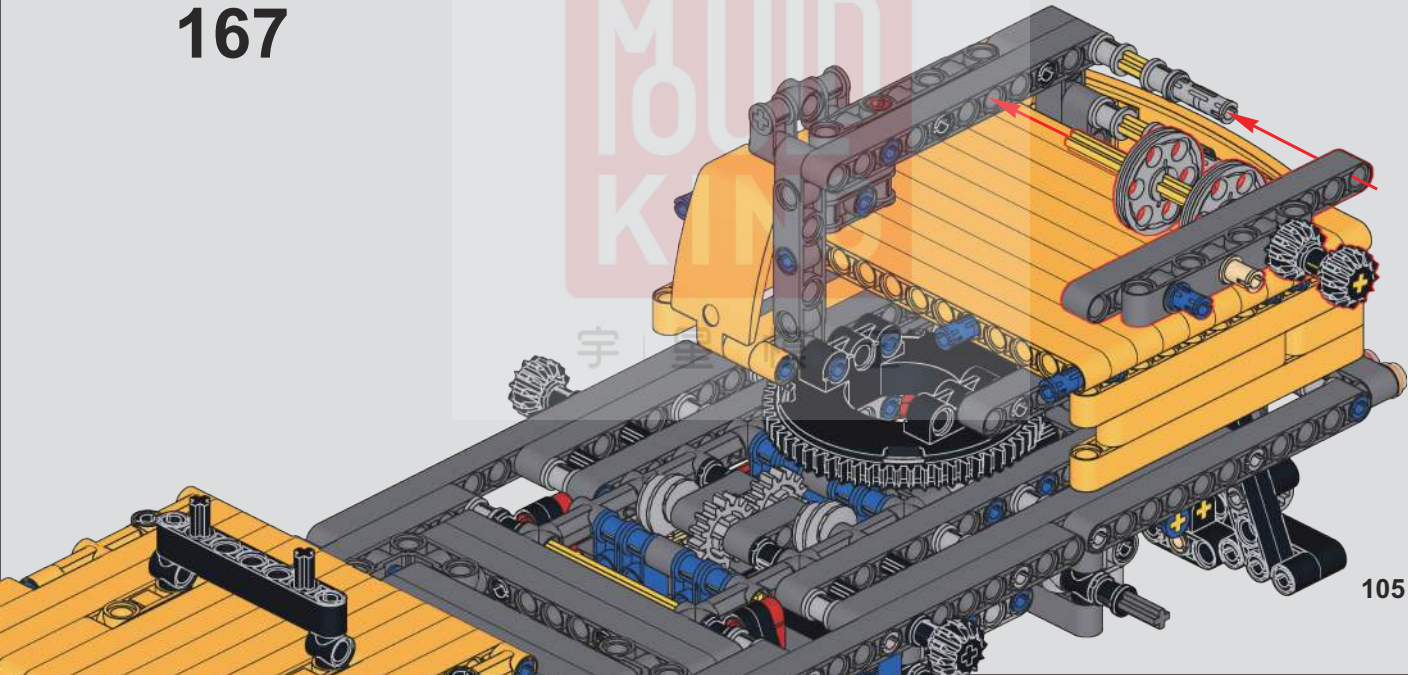
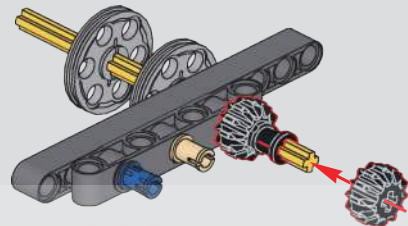

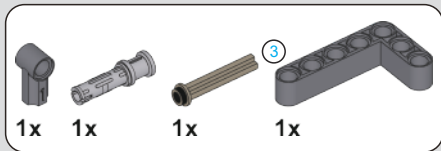

168

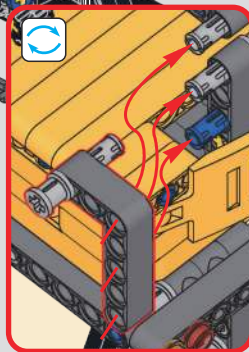
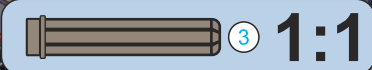
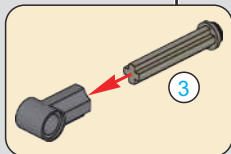

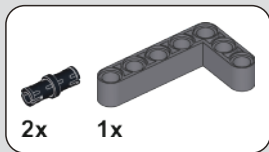

169

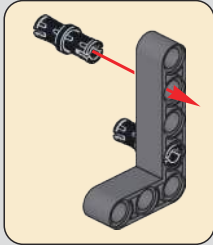
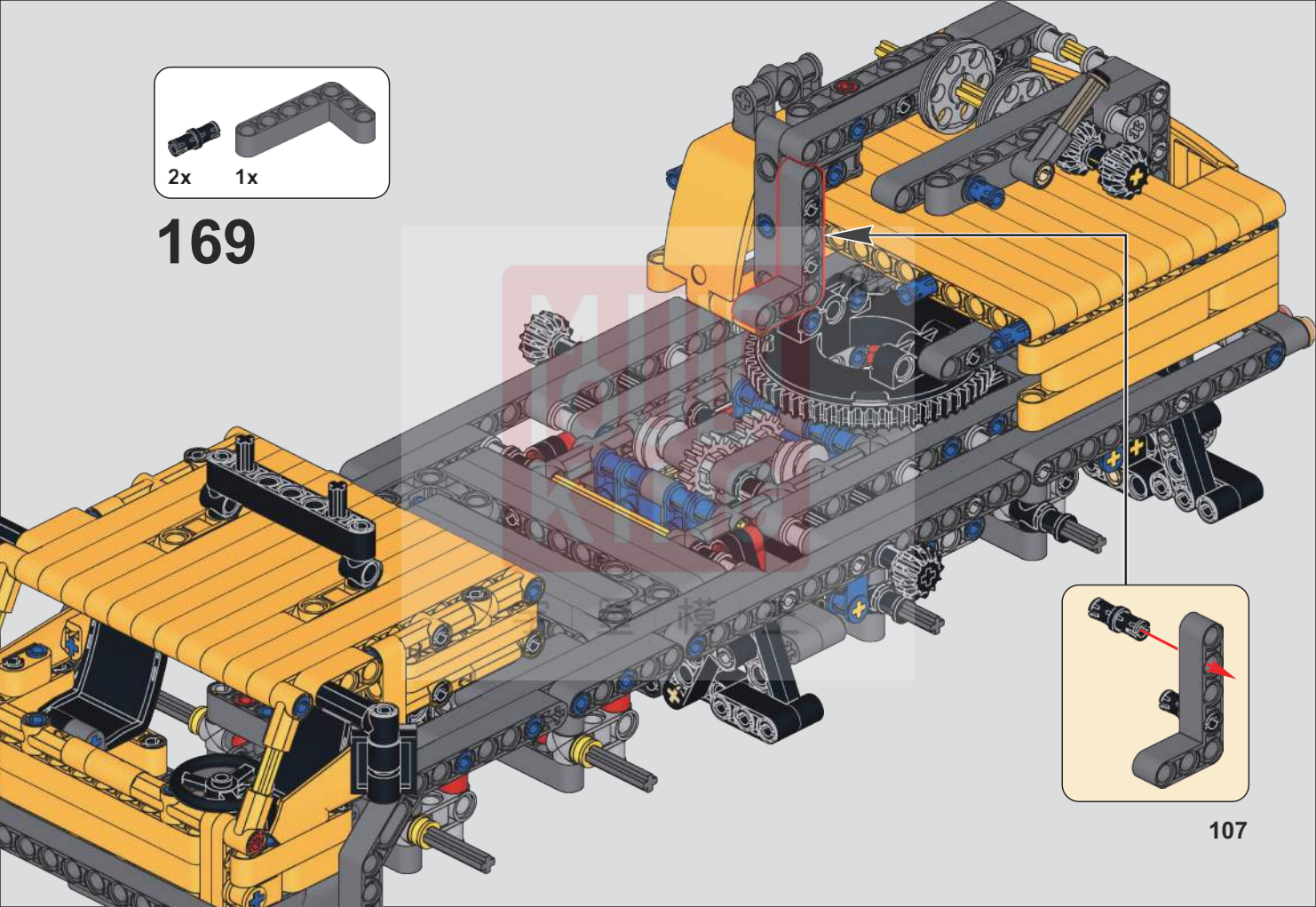

107

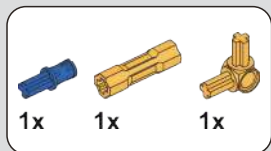
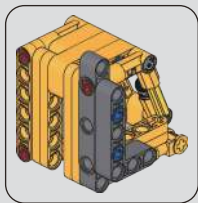

170

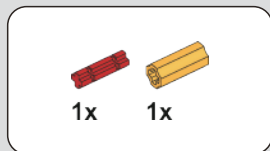
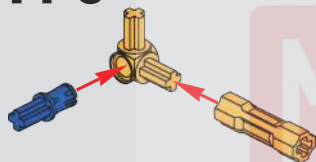

171

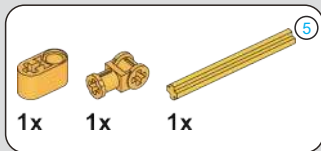
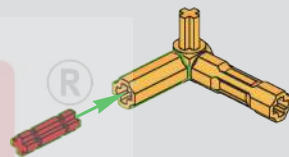

172

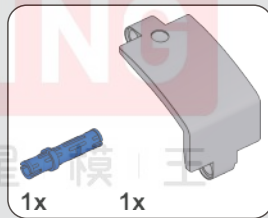
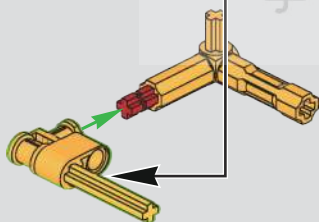
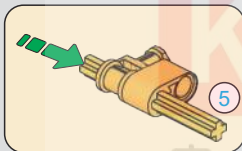

173

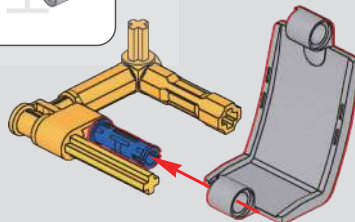

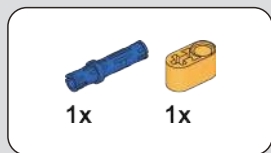

174

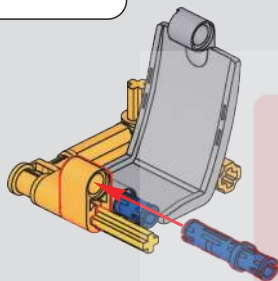

175

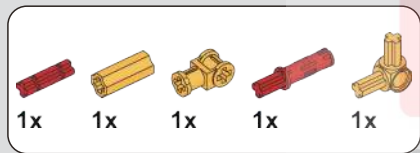
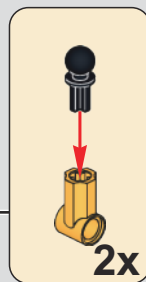
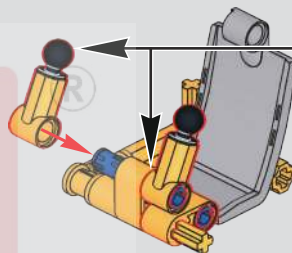

176

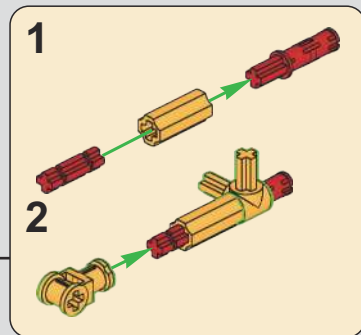
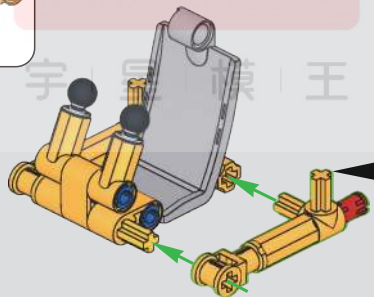



177

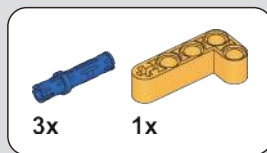
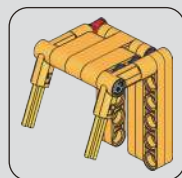
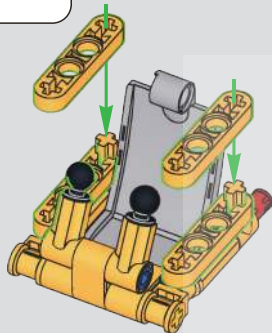

178

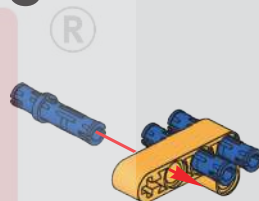

179

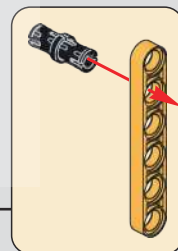
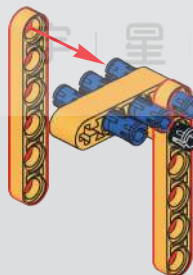

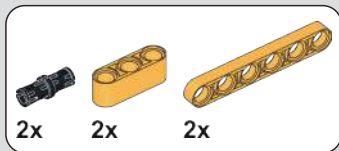

180

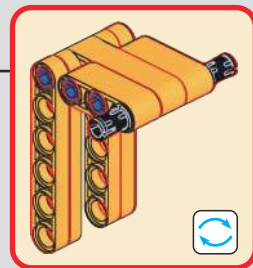
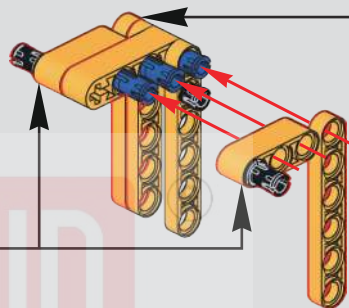
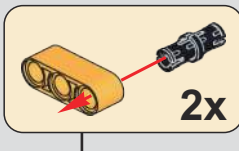

181

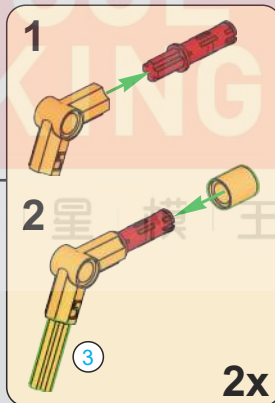
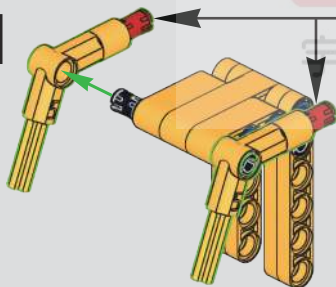

182

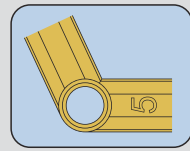
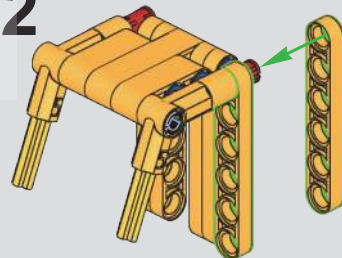

183

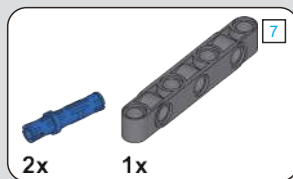
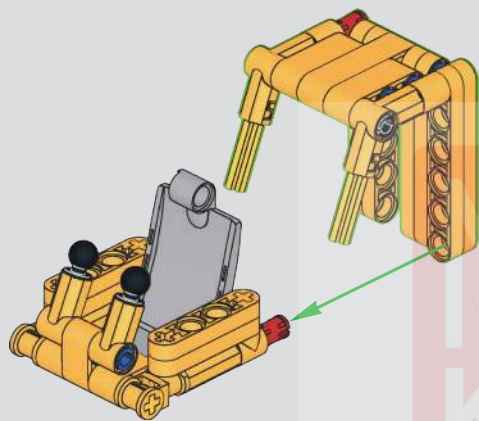

2x

1x

184

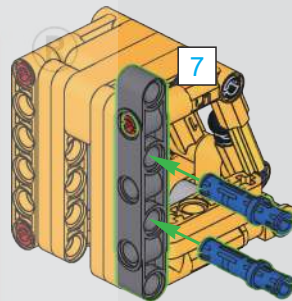

7

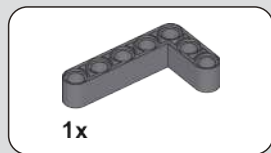

1x

185

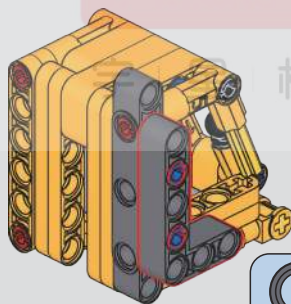

7

1:1

186

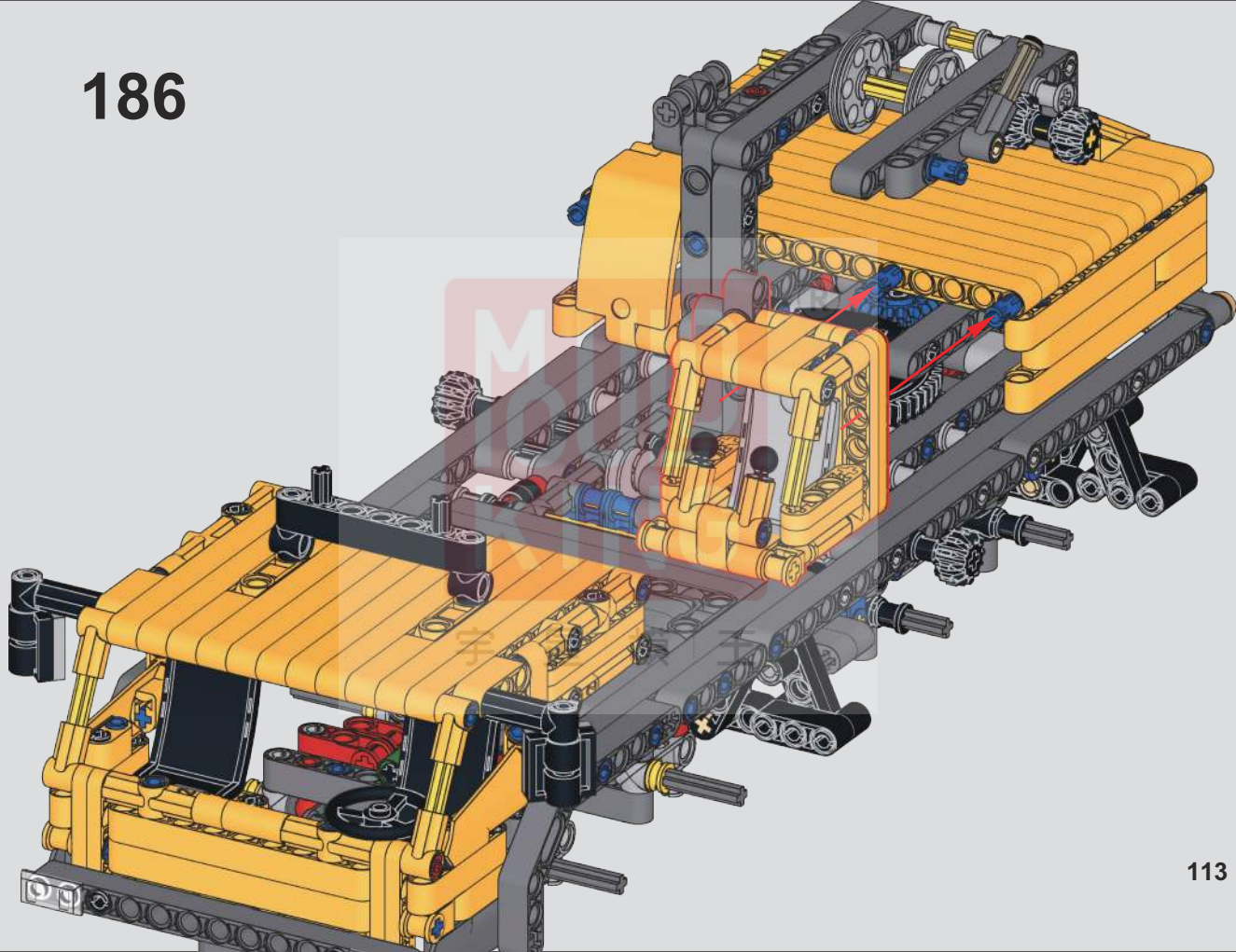

113



(光滑栓)(Technic Pin without Friction)

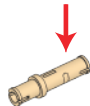

1x

1x

187



3

1:1

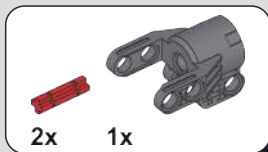
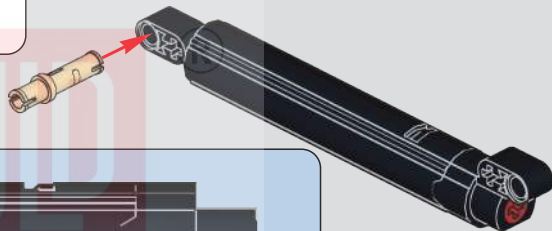

2x

1x

188

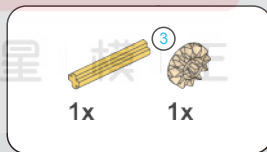

1x

1x

189

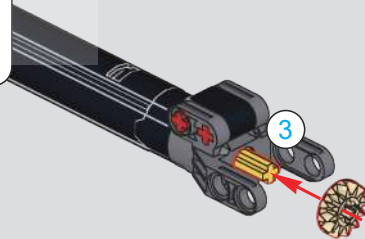

3

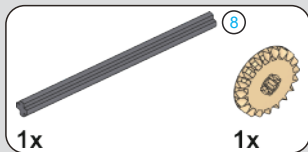

190

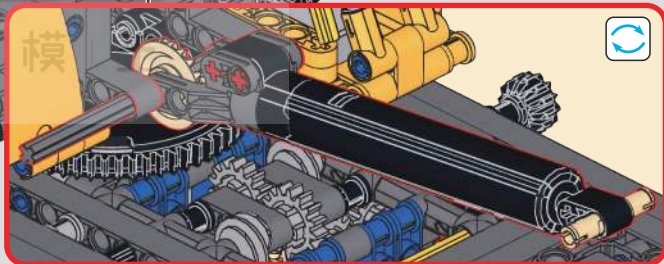
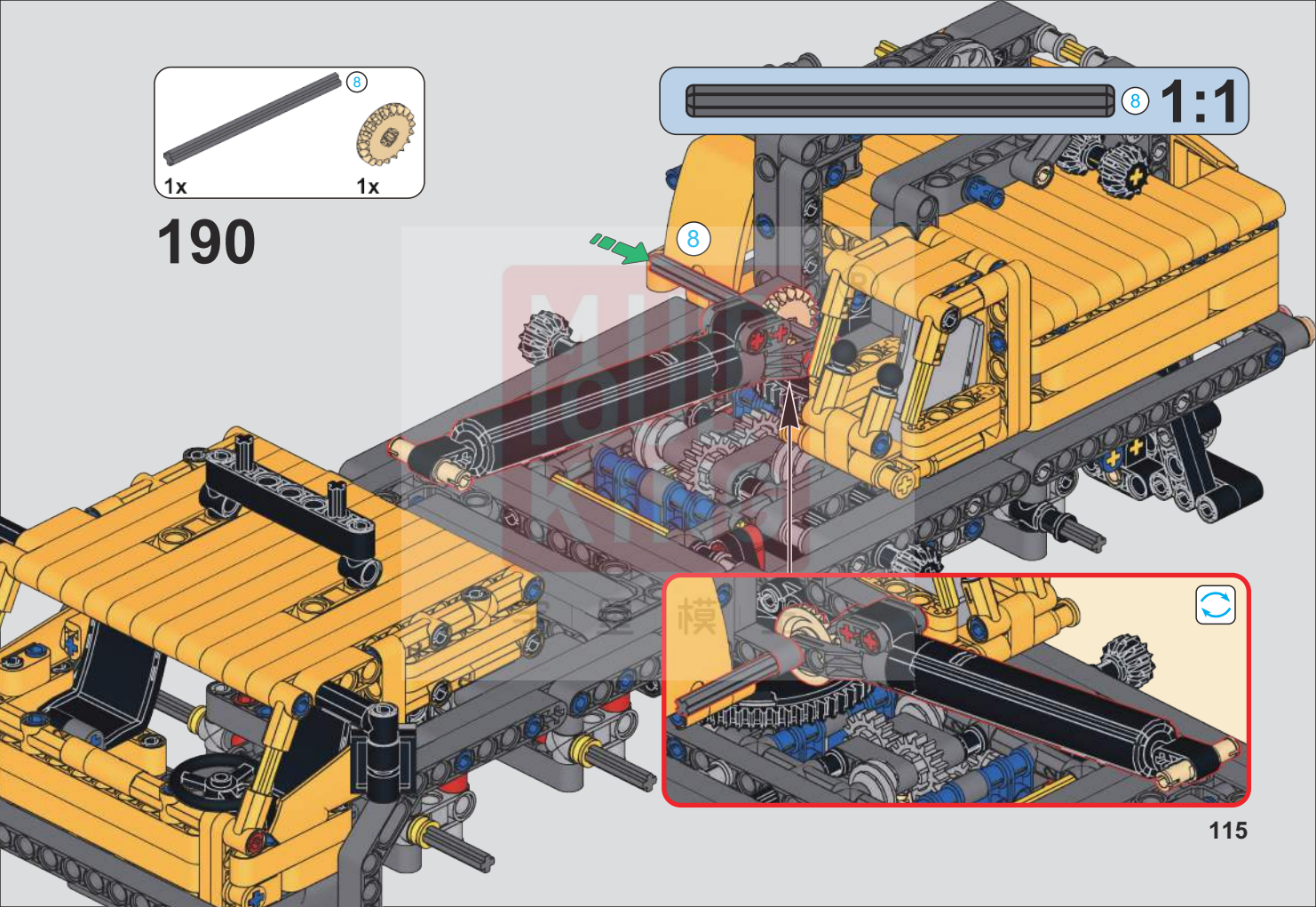
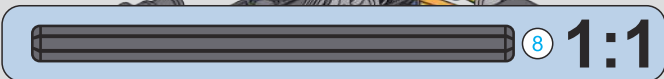



1x



2x



1x

191

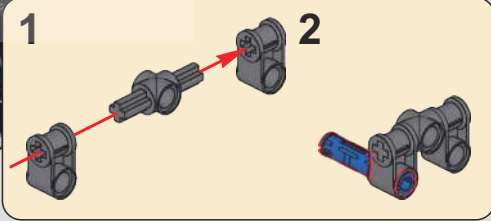
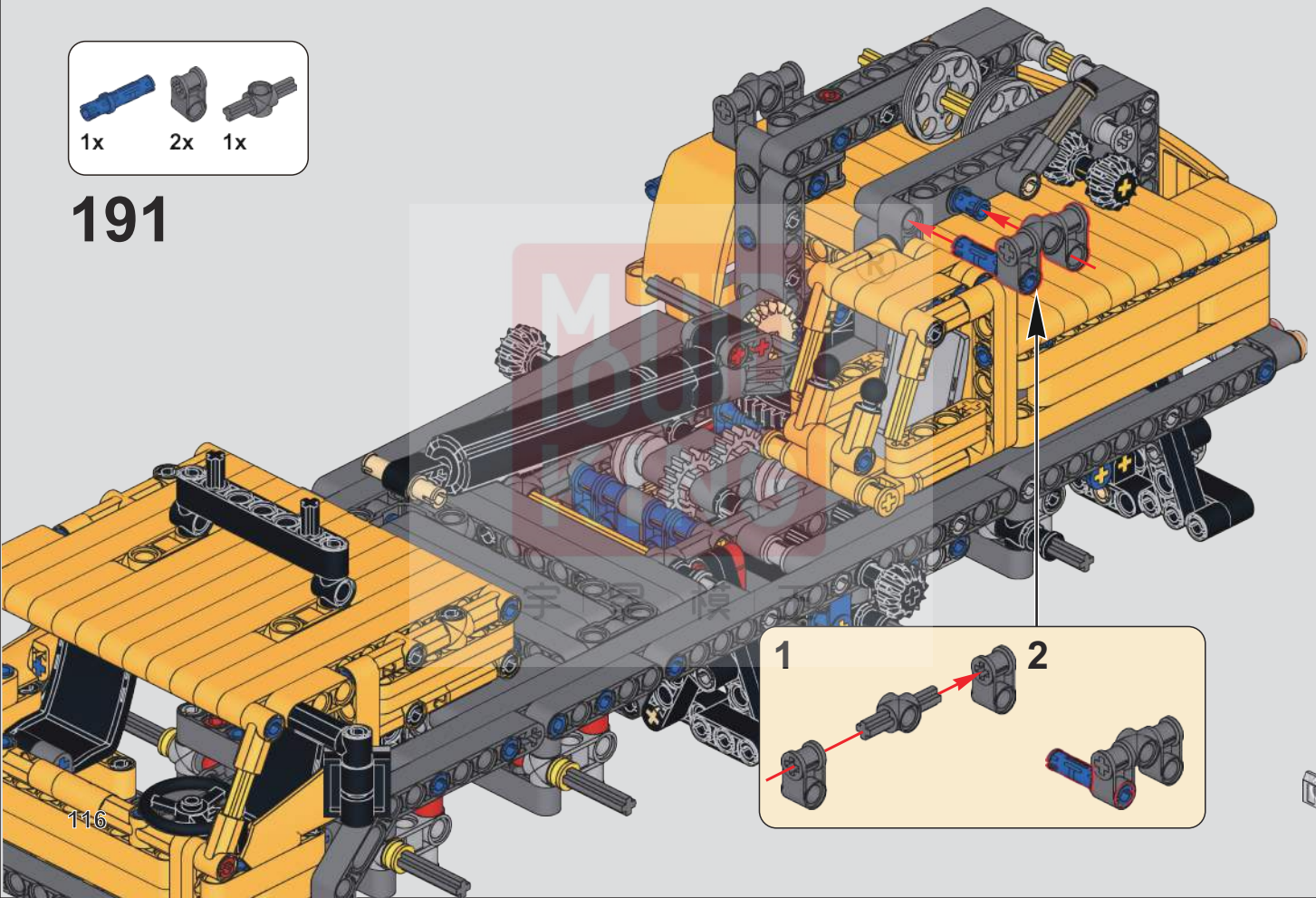

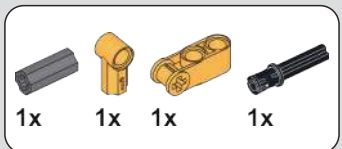

192

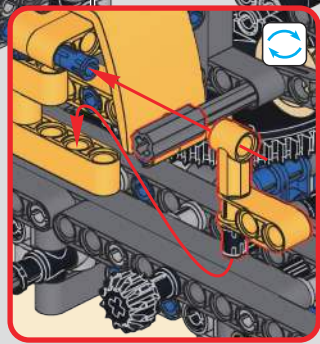
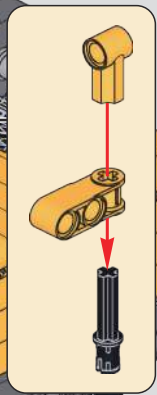
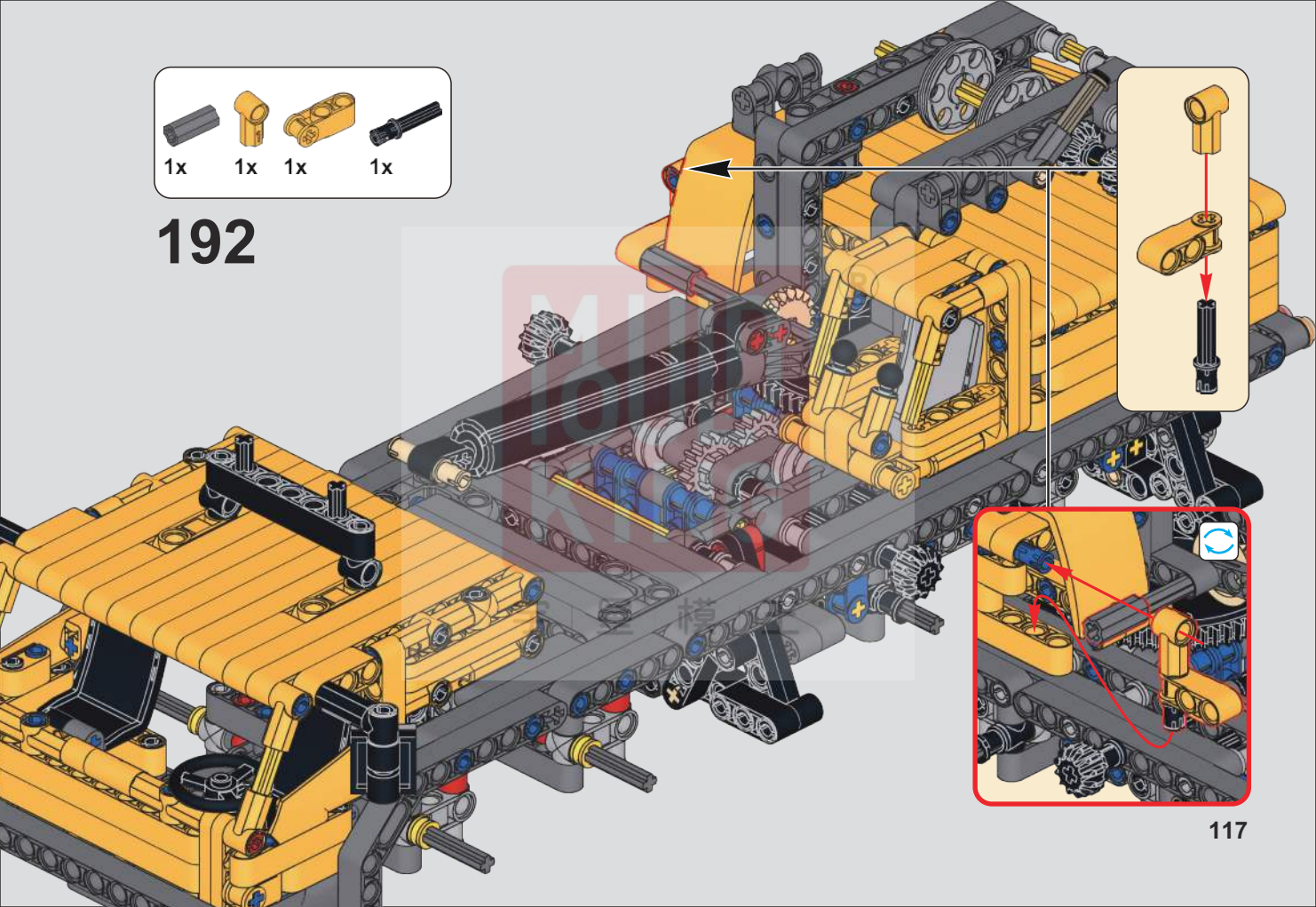

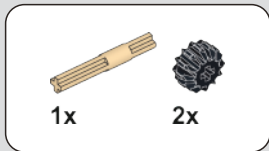

193

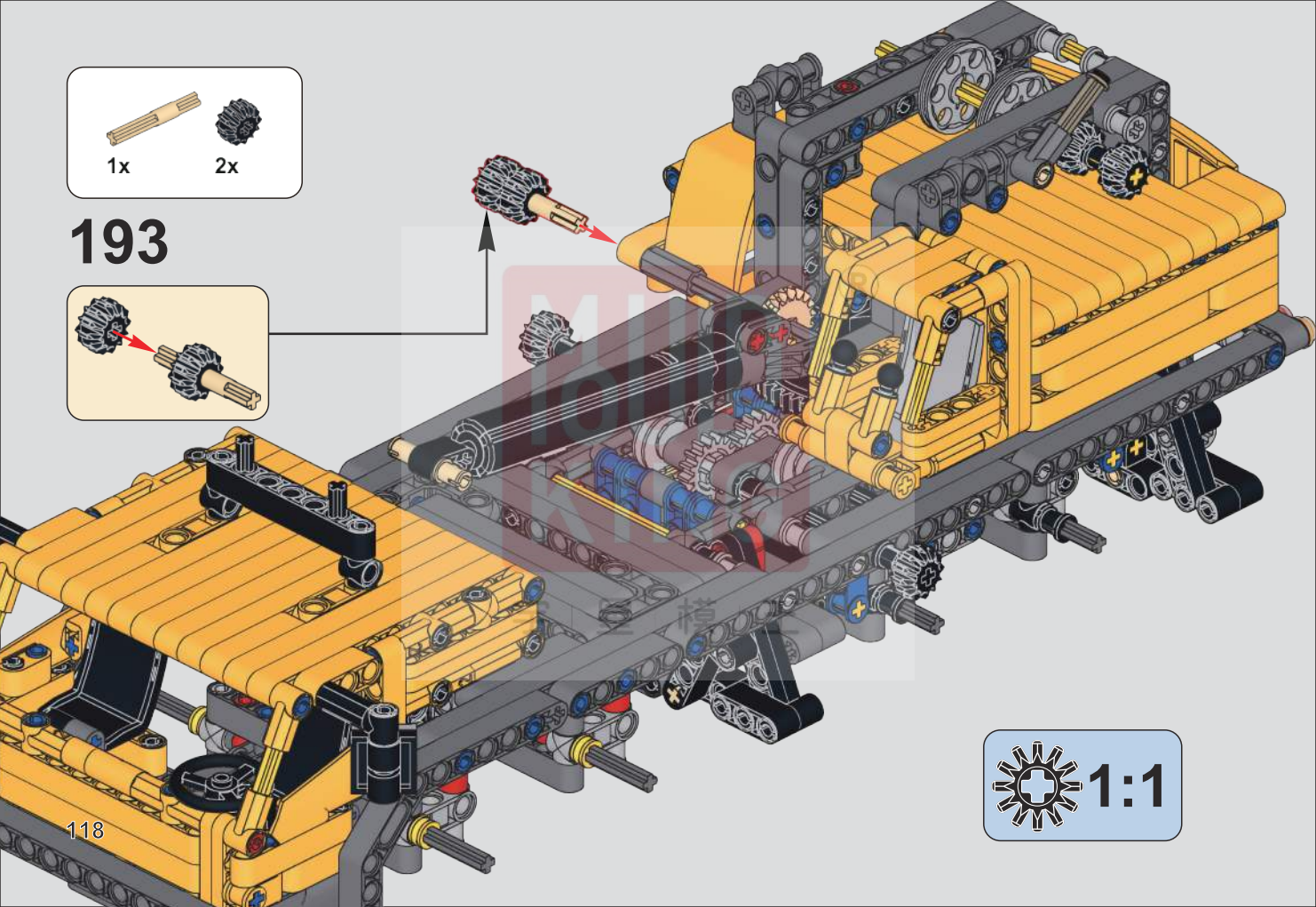
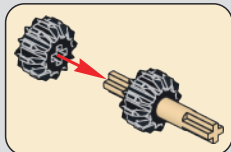

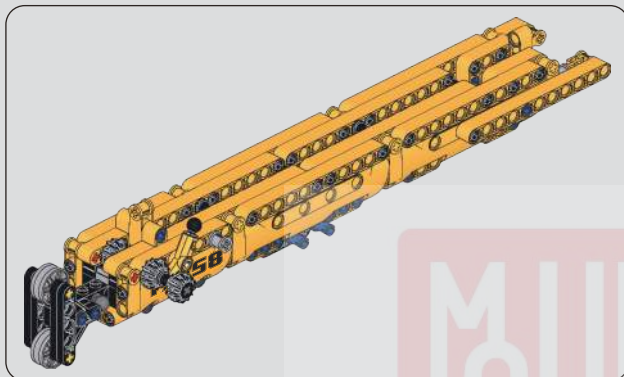

194

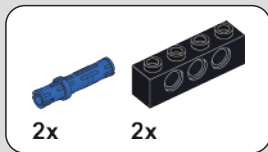
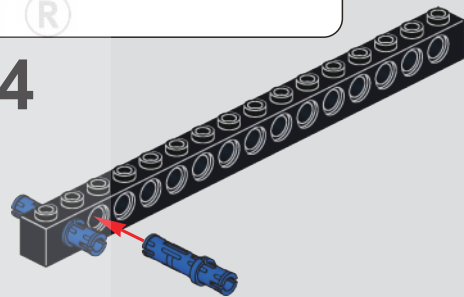

195

宇 | 星 | 模 | 王

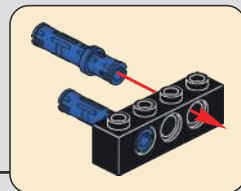
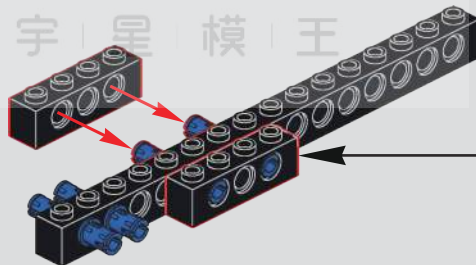

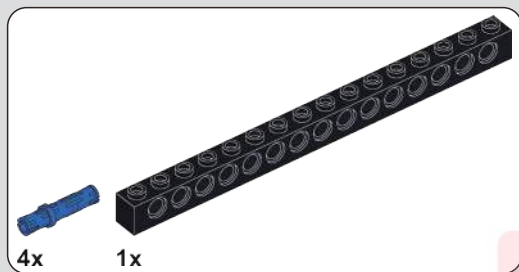

196

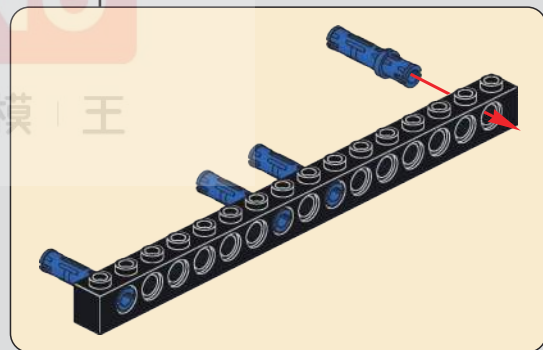
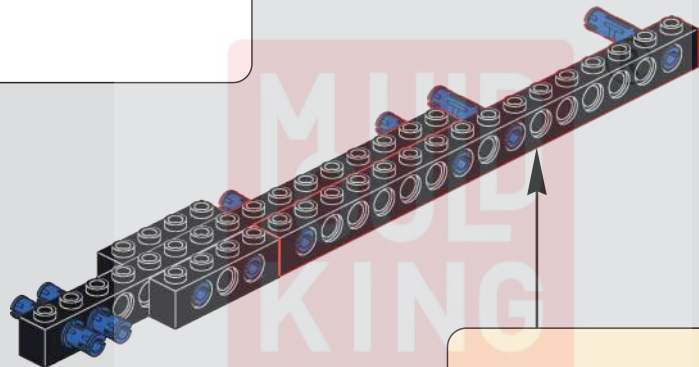

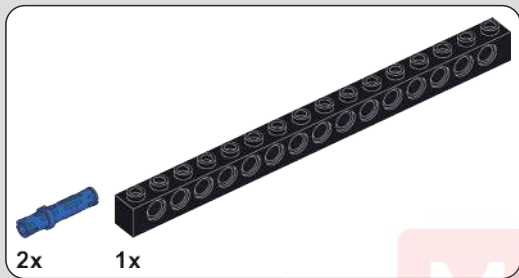

197

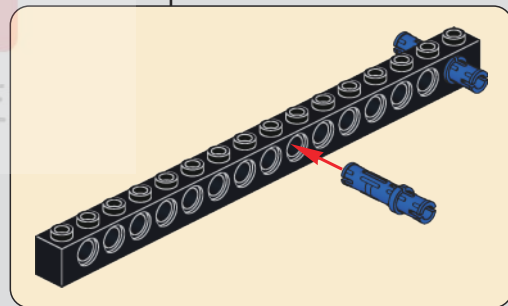
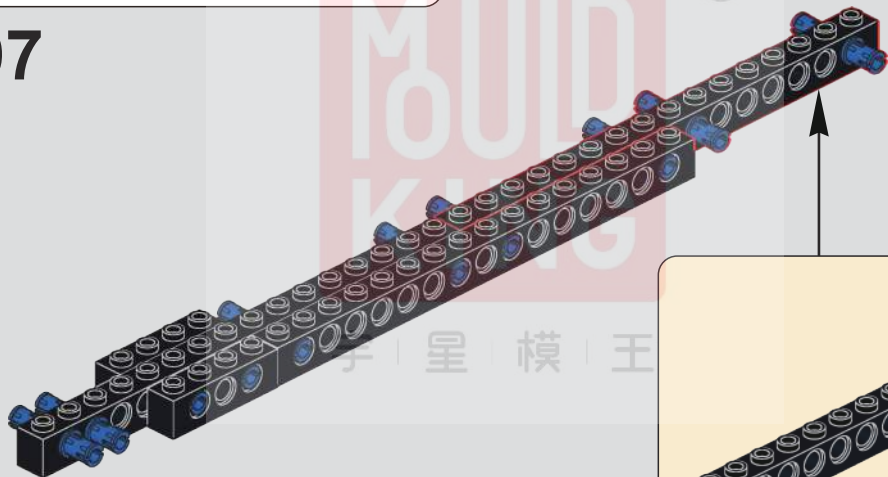

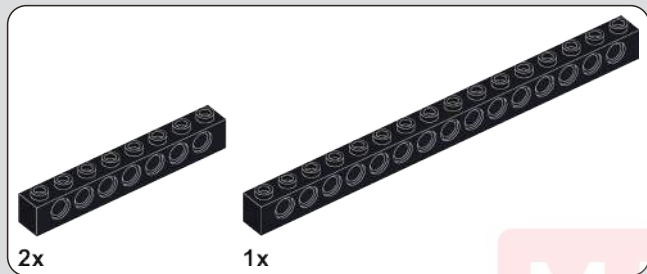

198

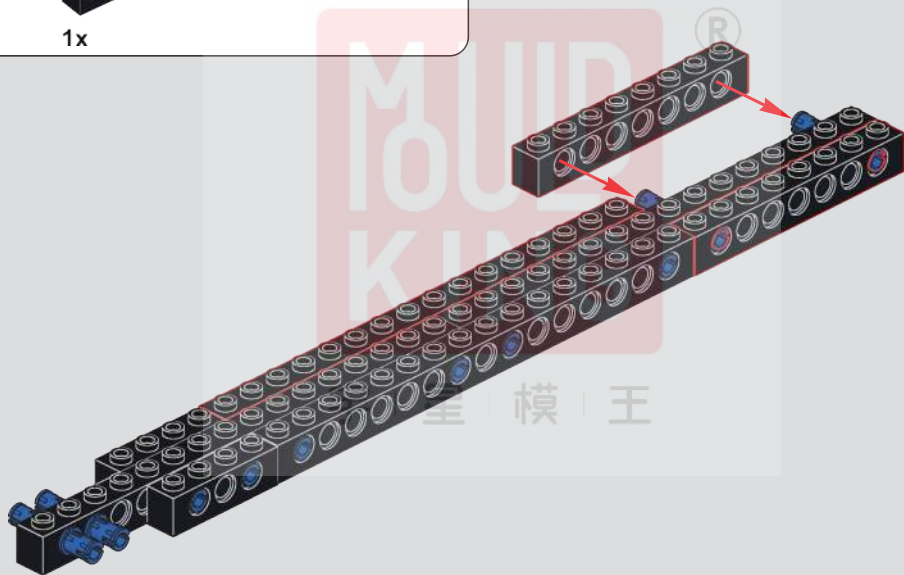

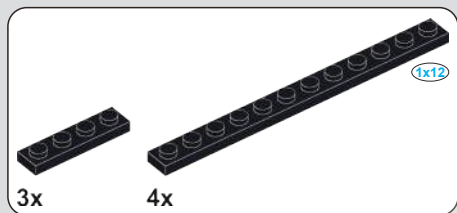

199



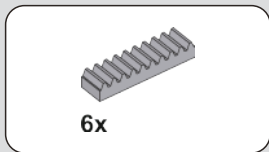

200



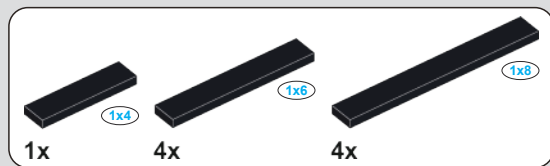

201

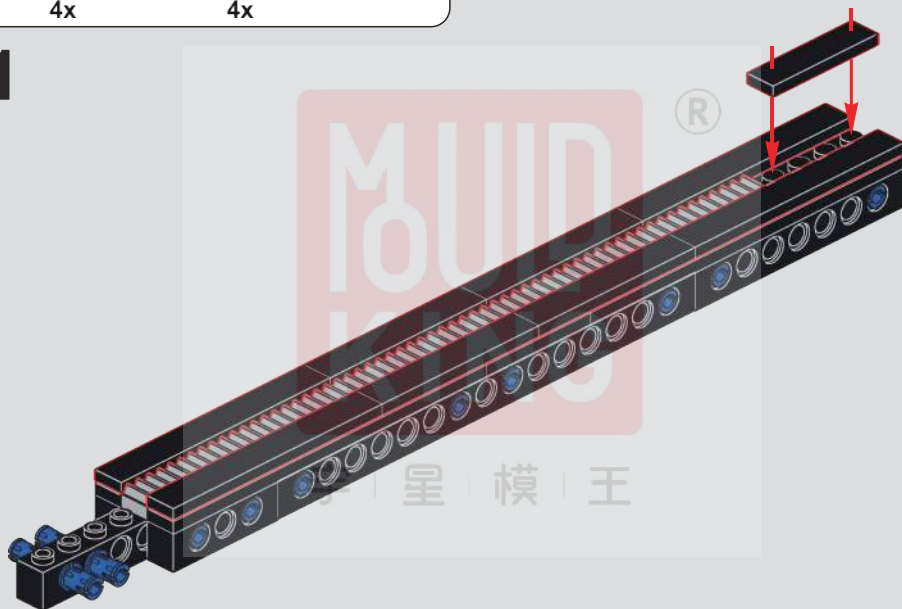

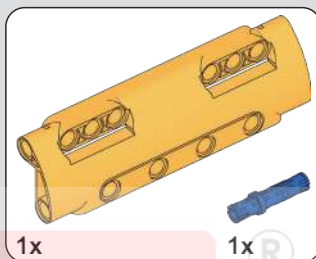
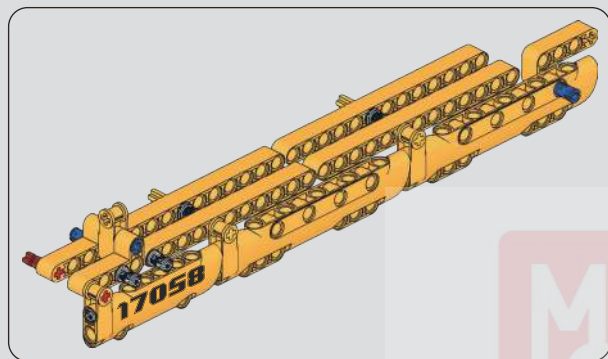

202

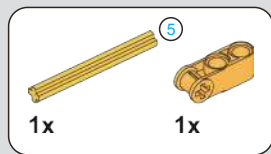
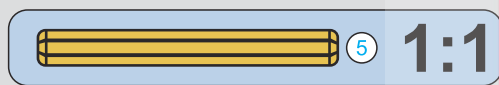
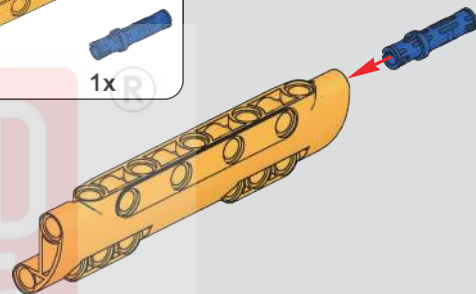

203

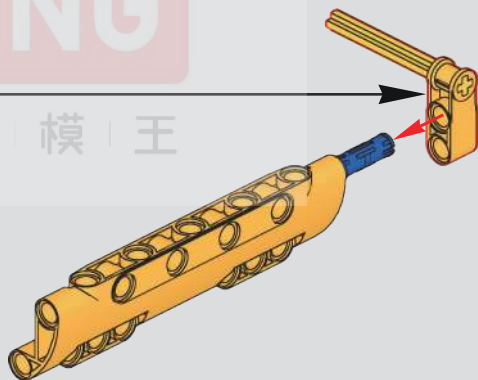

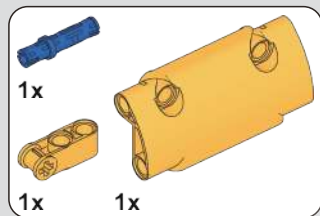

204

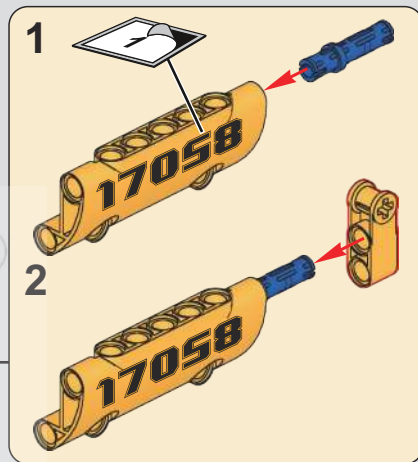
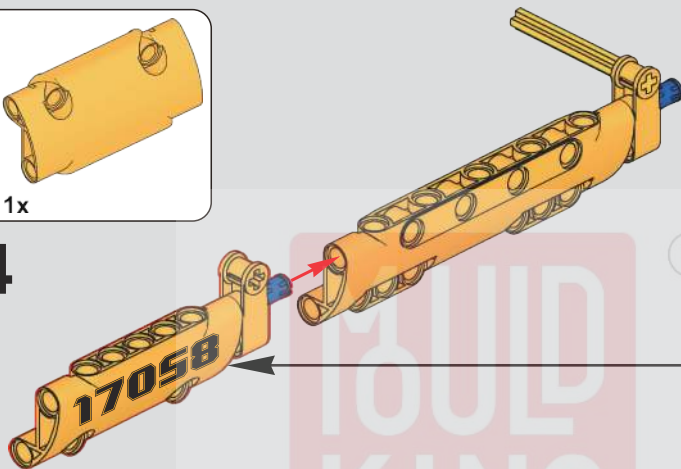

205

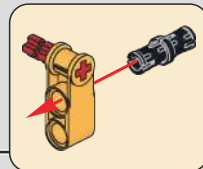
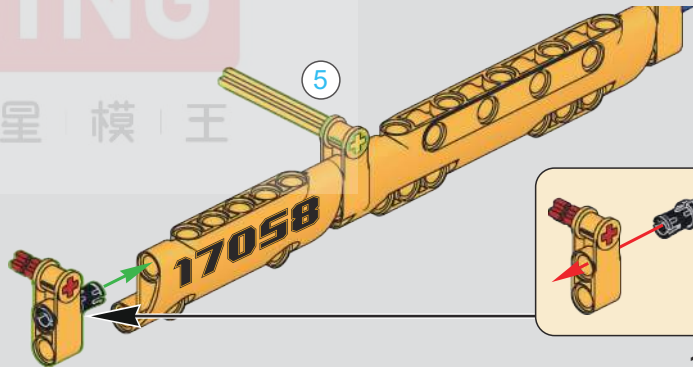

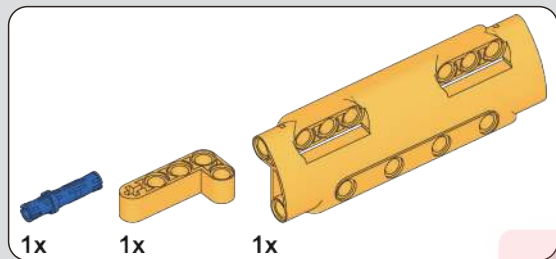

206

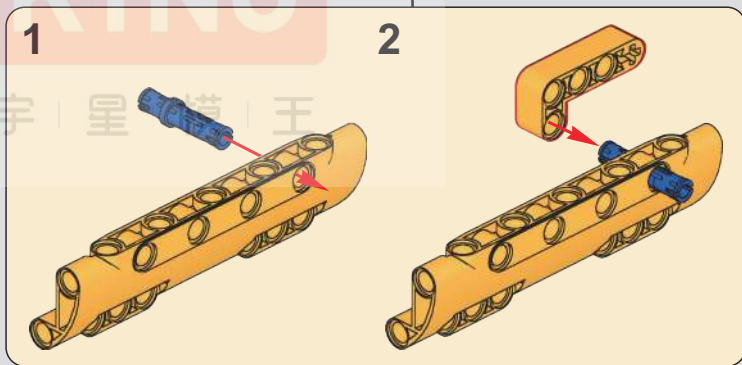
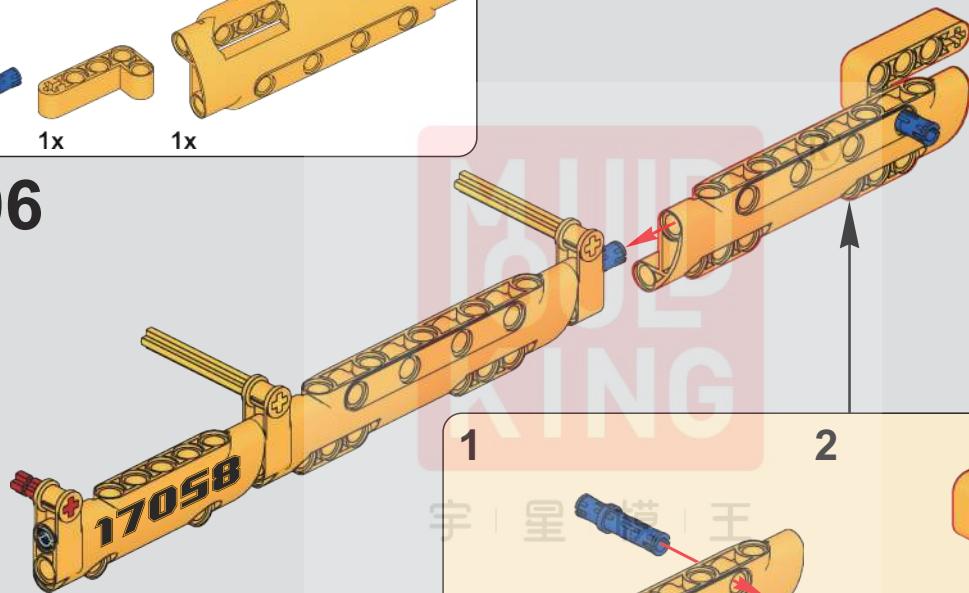

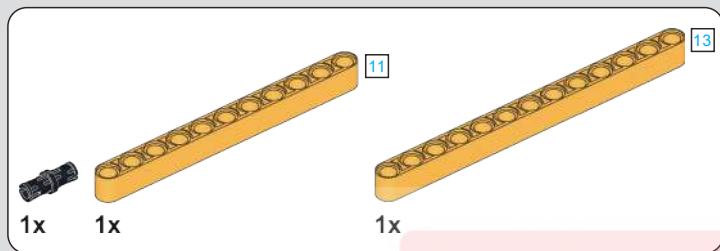

207

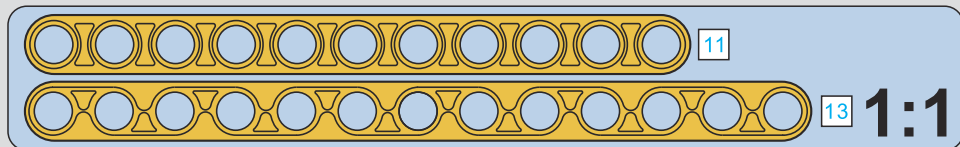
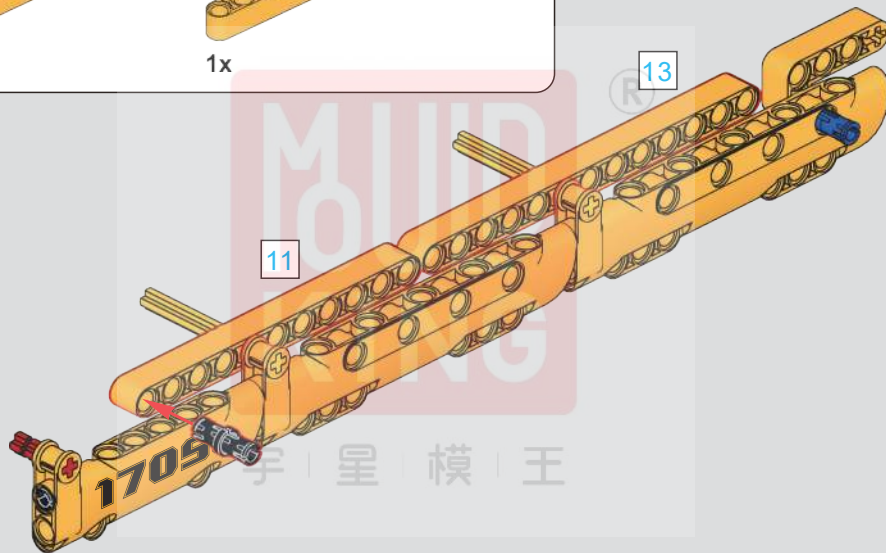



2x

208

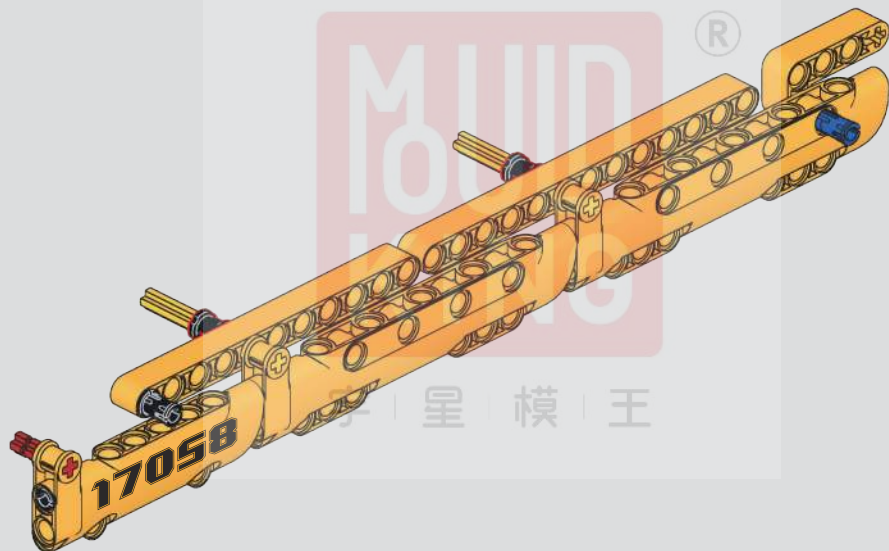

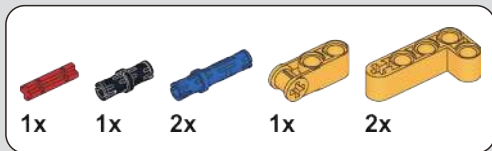

209

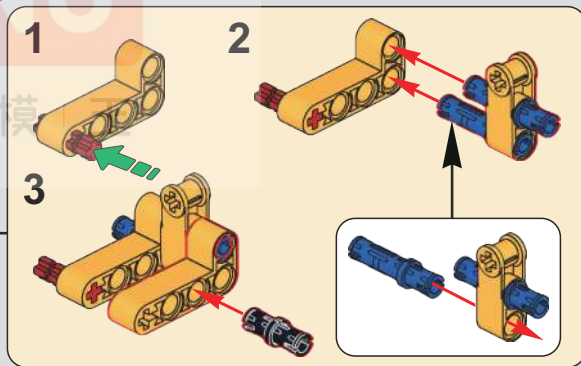
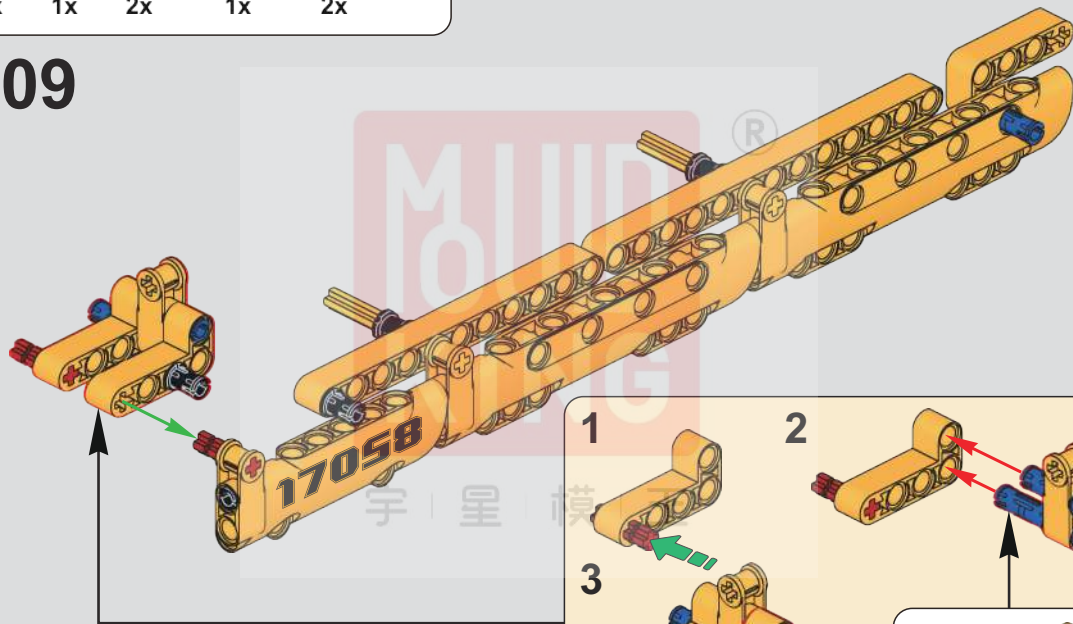

210

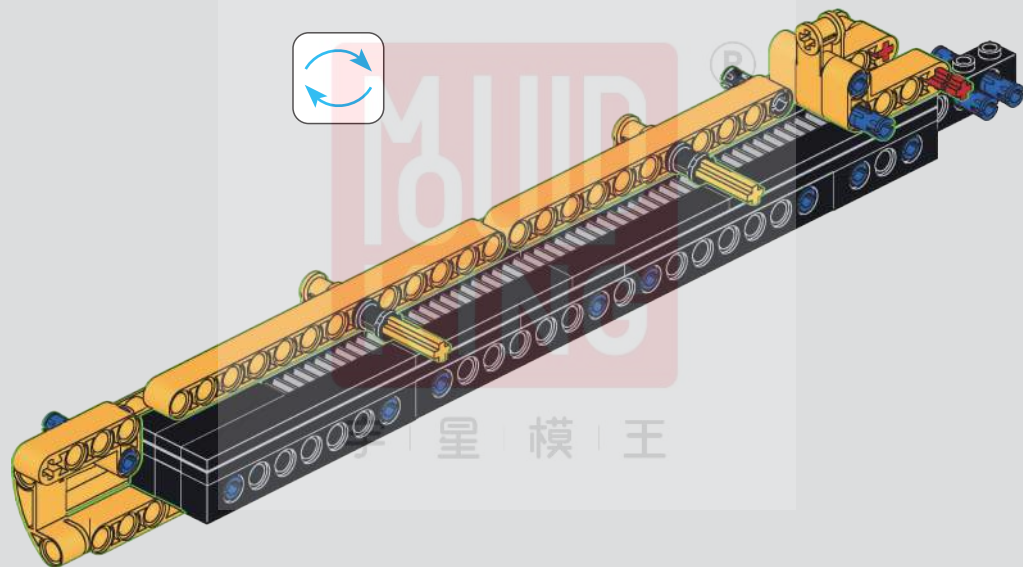

132

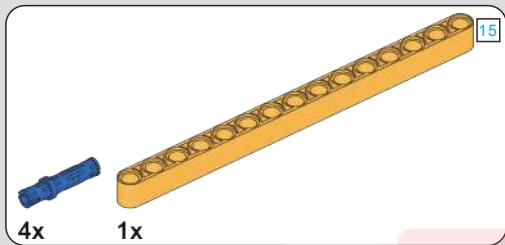

211

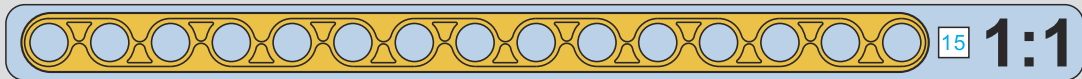
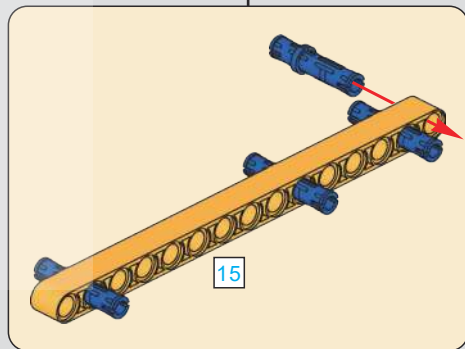
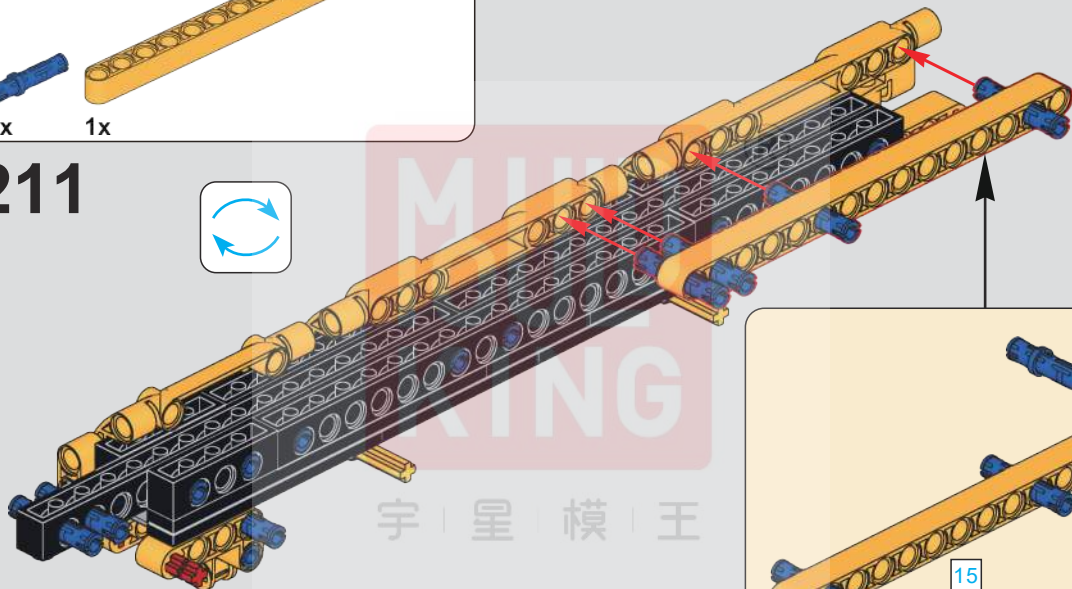

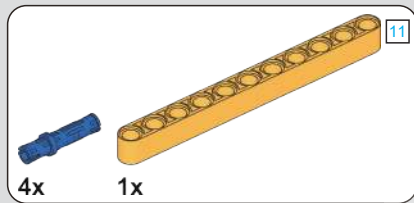

212

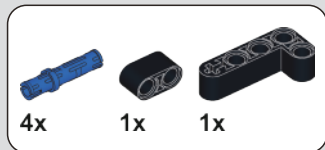
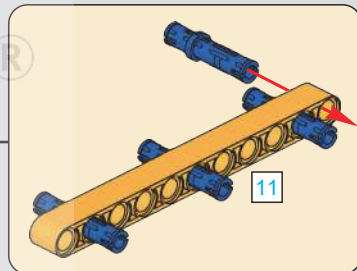
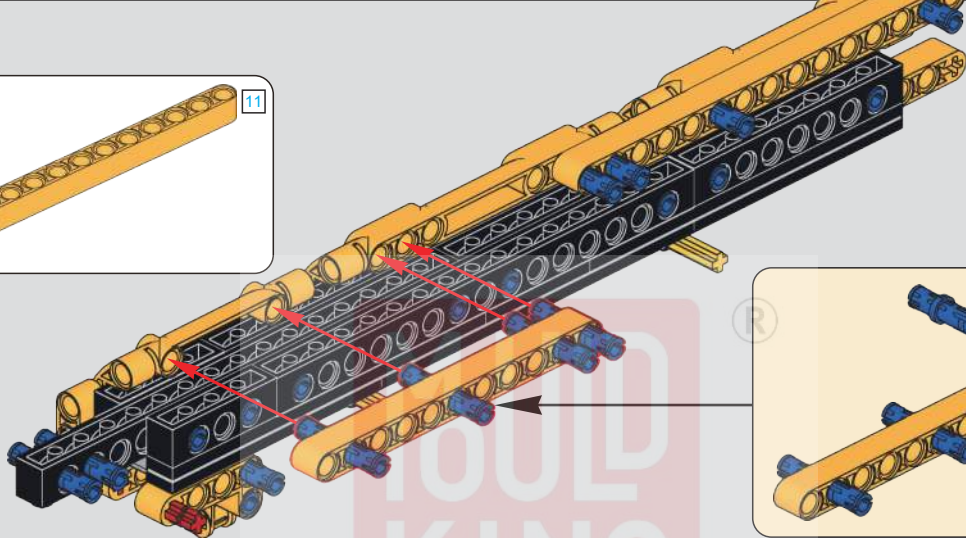

213

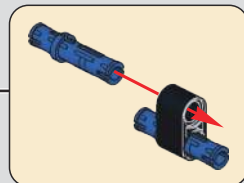
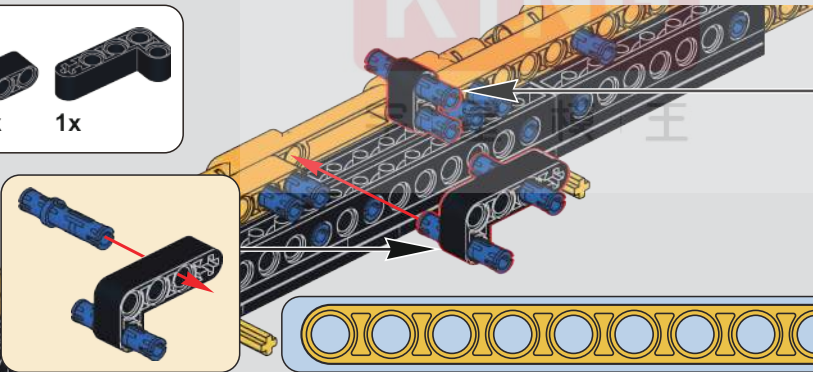

134

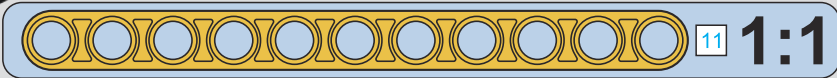

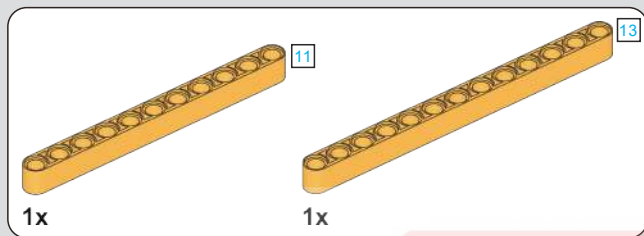

214

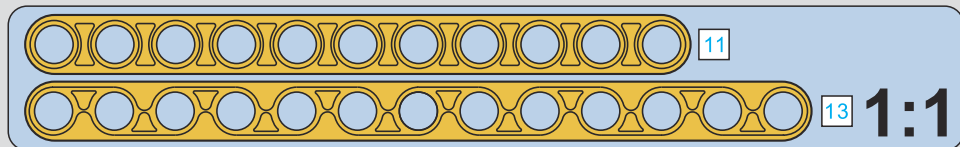
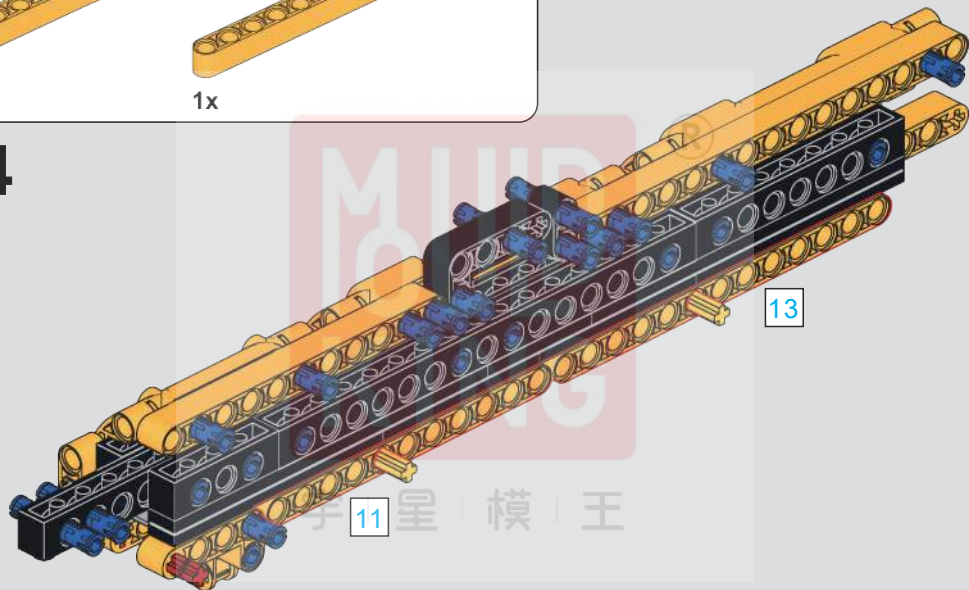

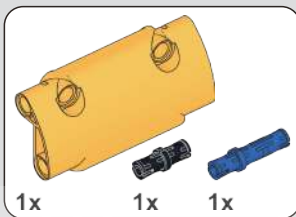
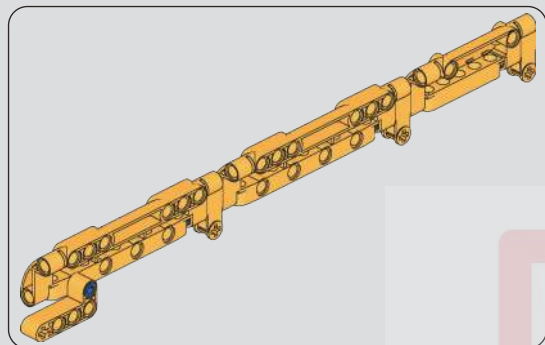

215

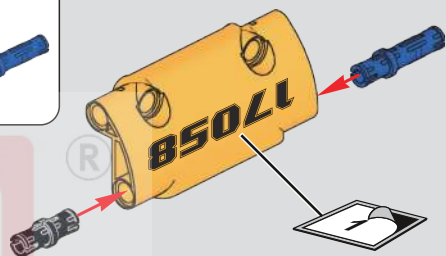

216

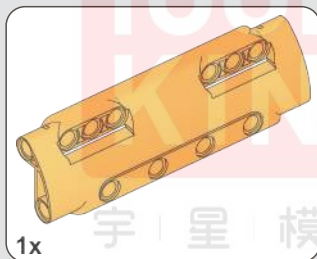
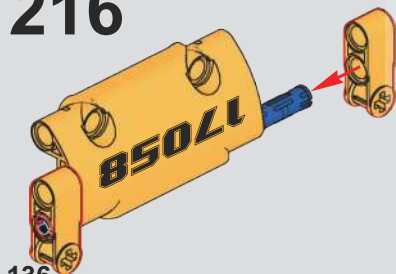

217

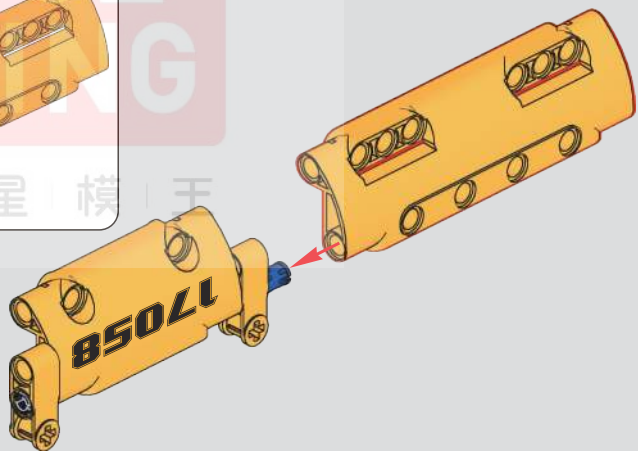

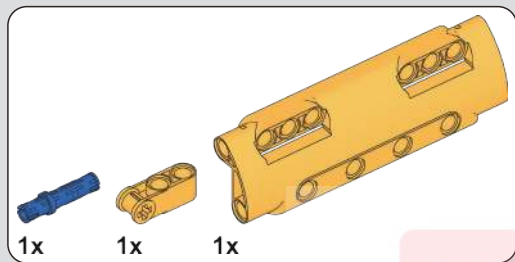

218

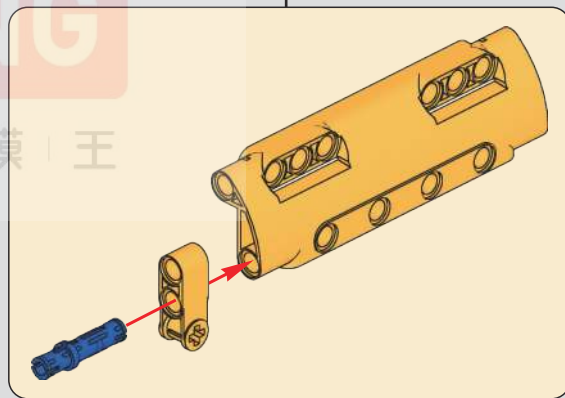
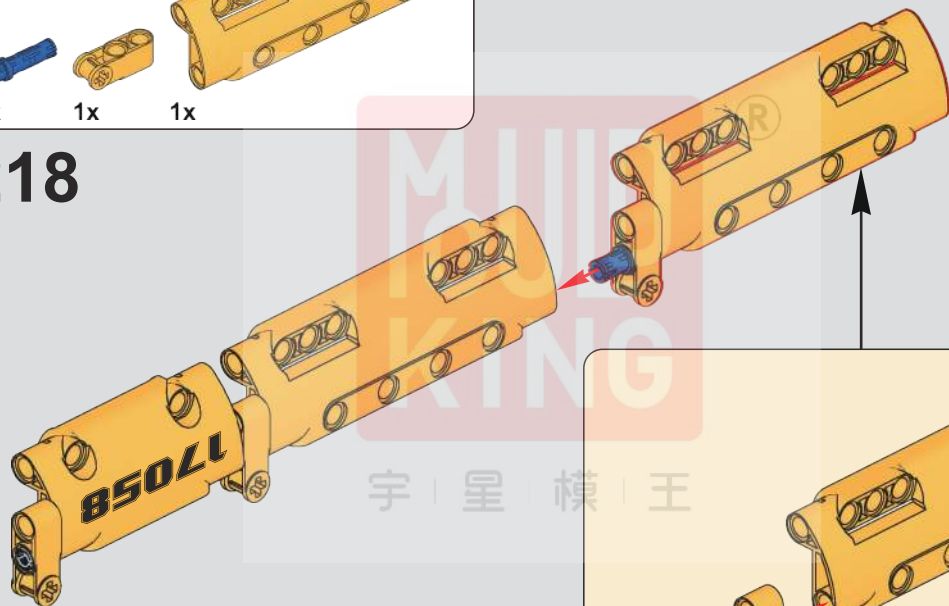

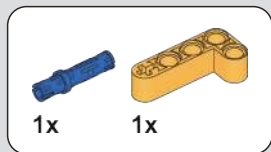

219

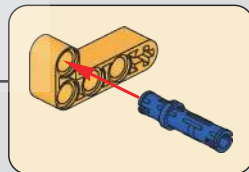
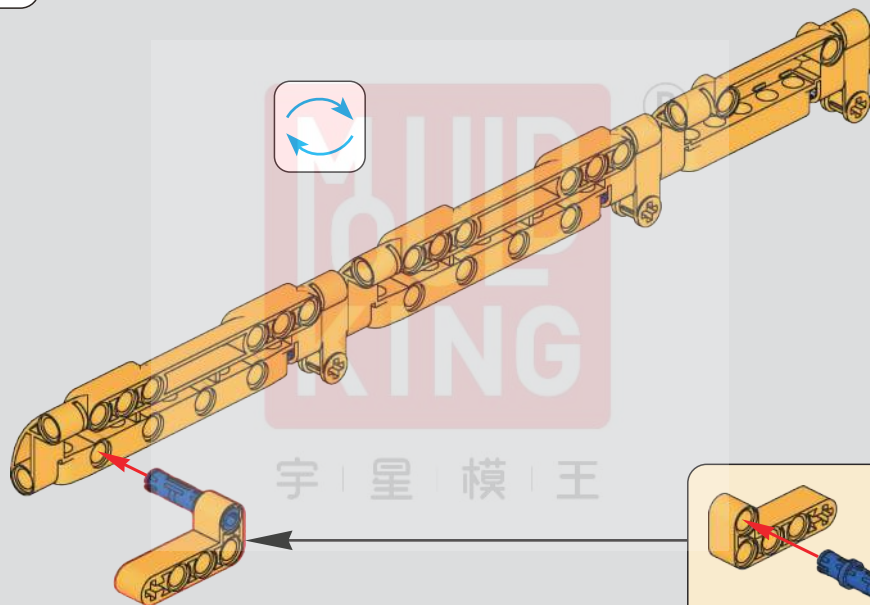

220

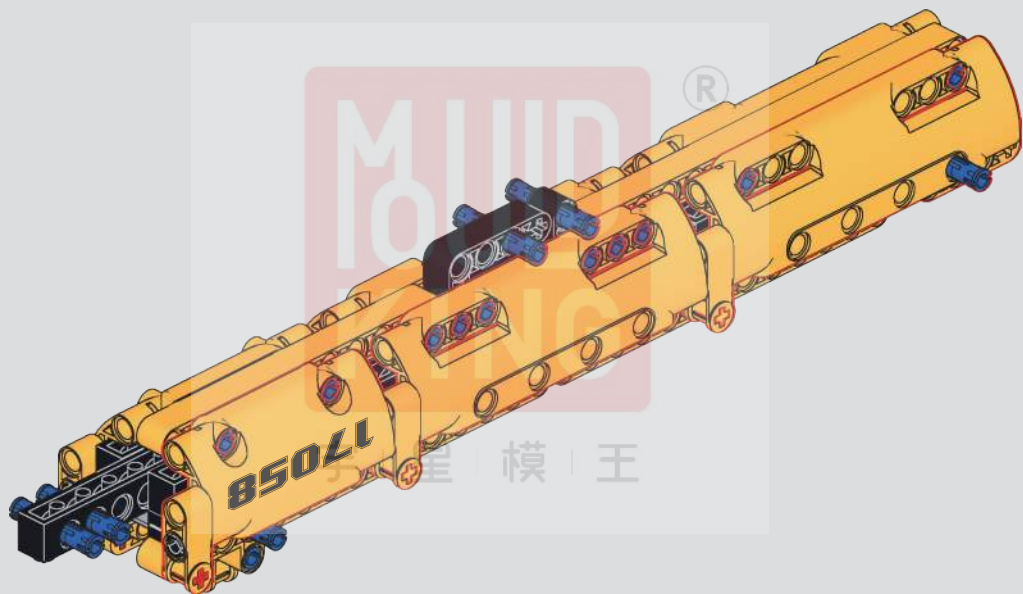

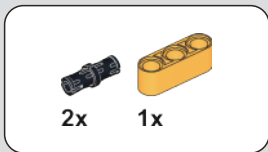

221

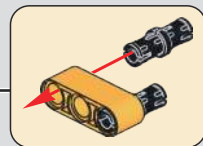
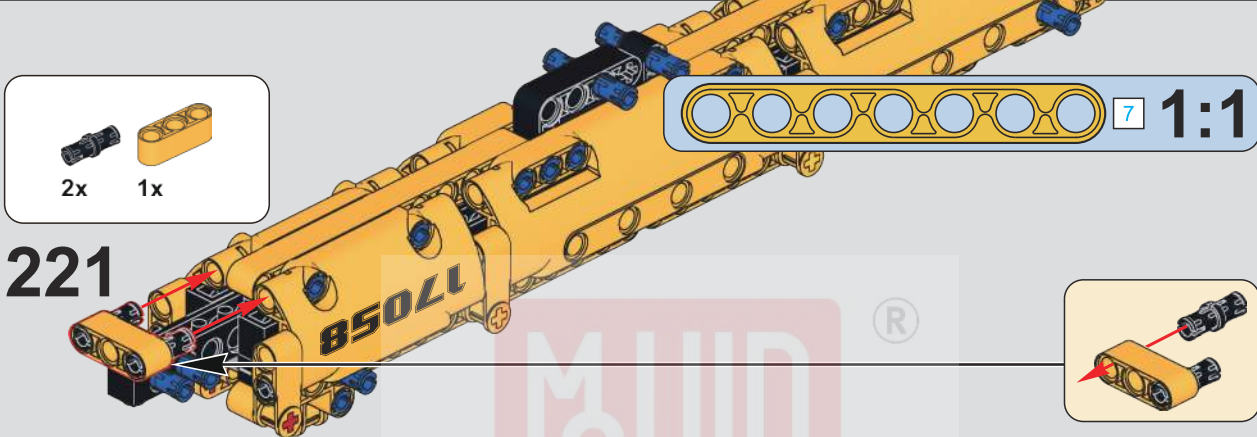

222

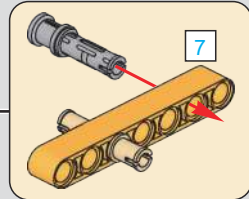
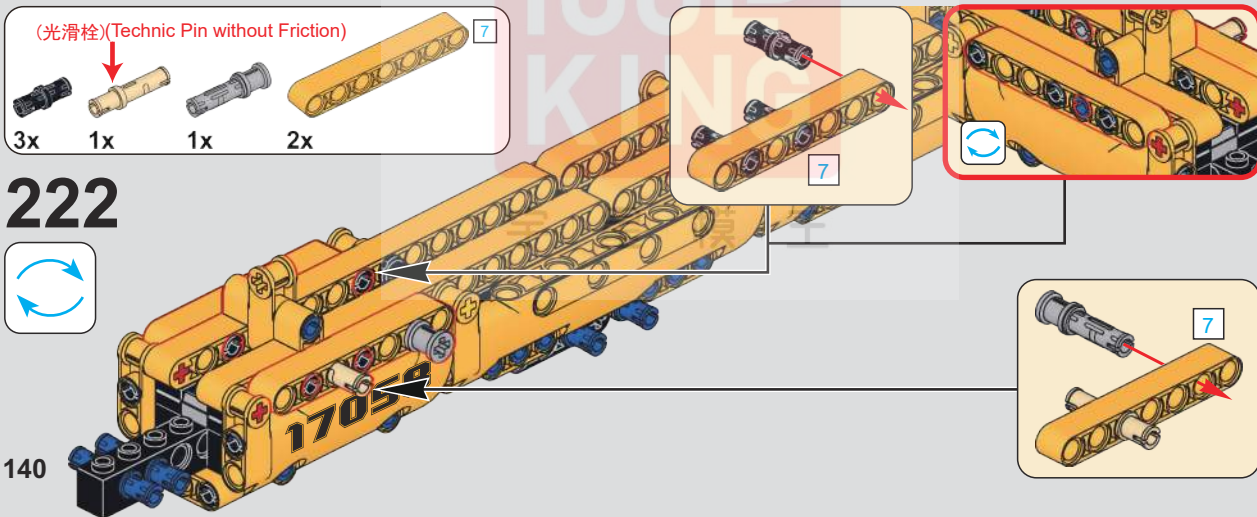

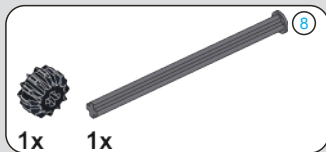

223

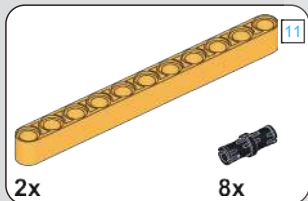
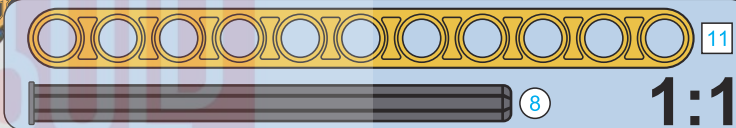
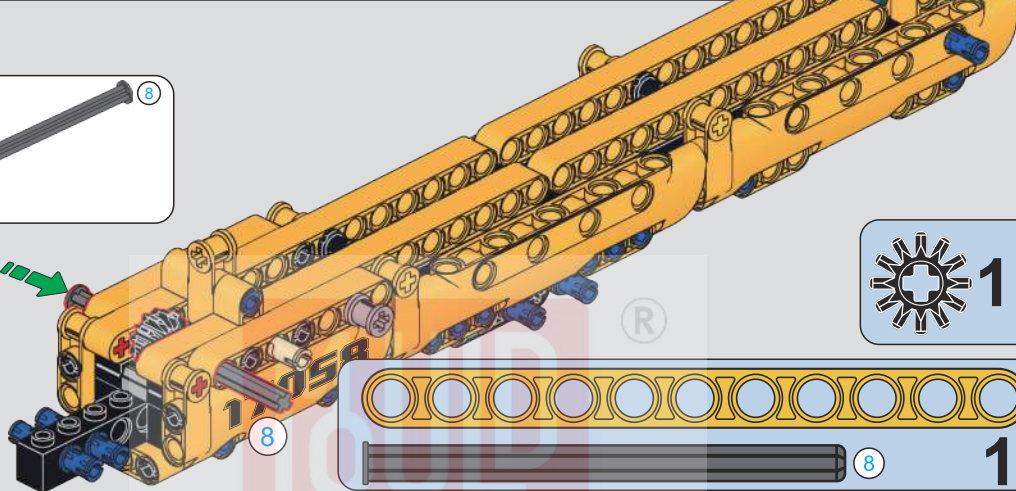

224

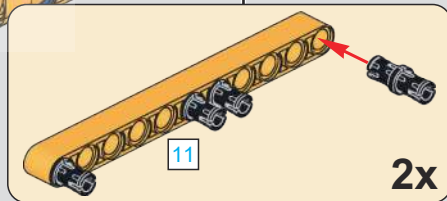
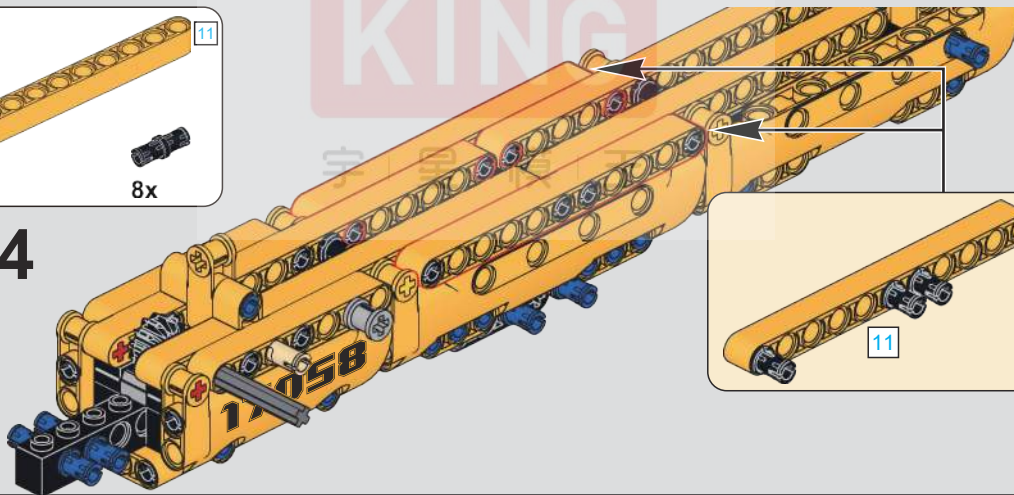

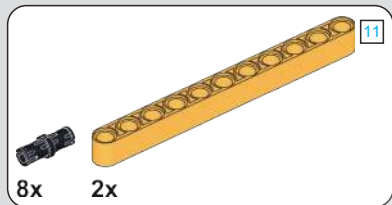

225

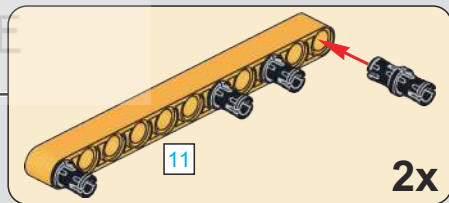
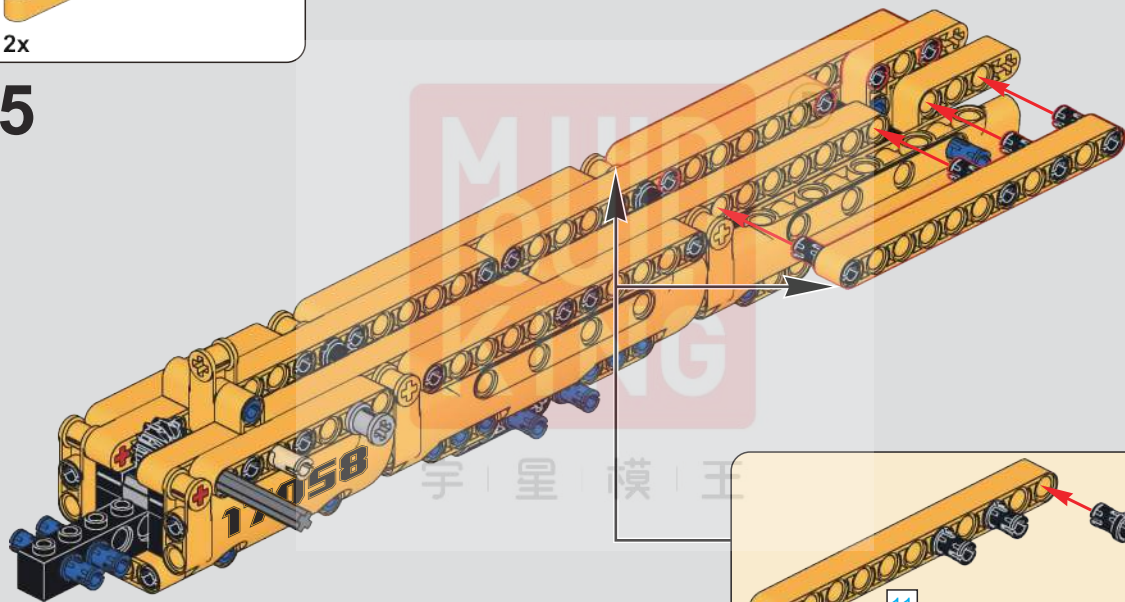
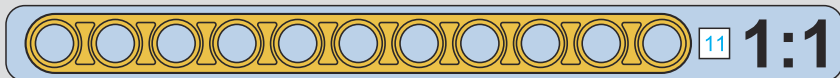

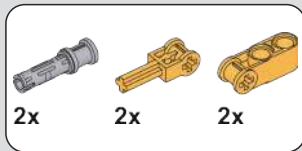

226

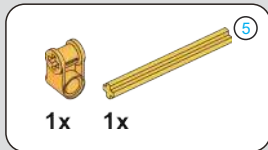
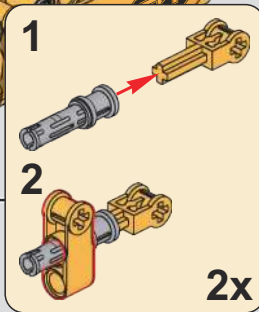
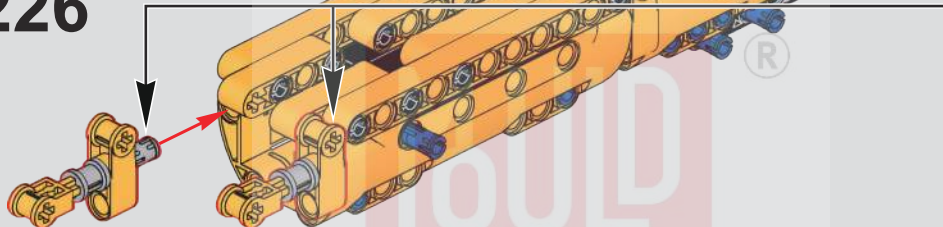

227

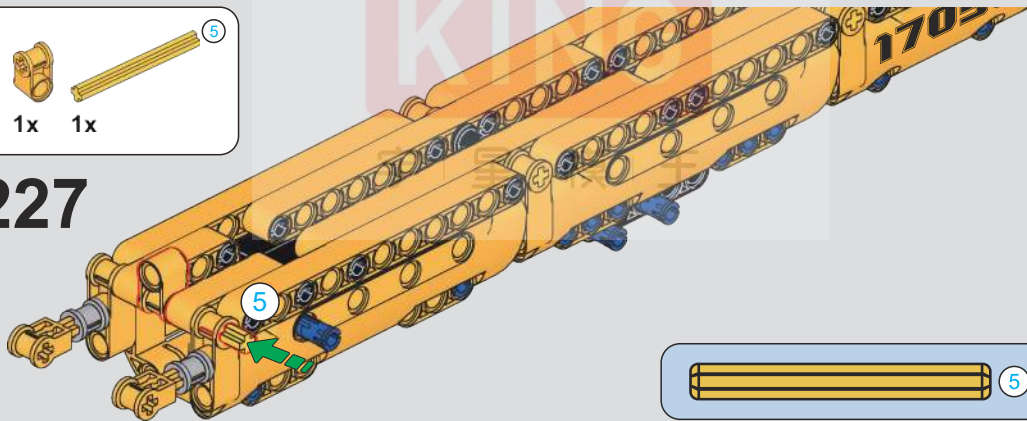

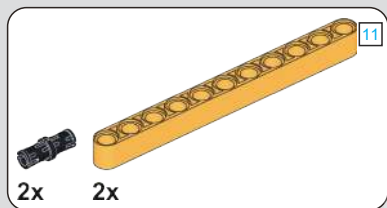

228

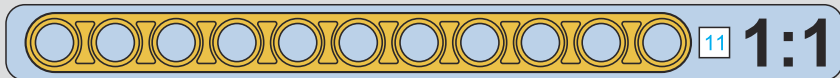
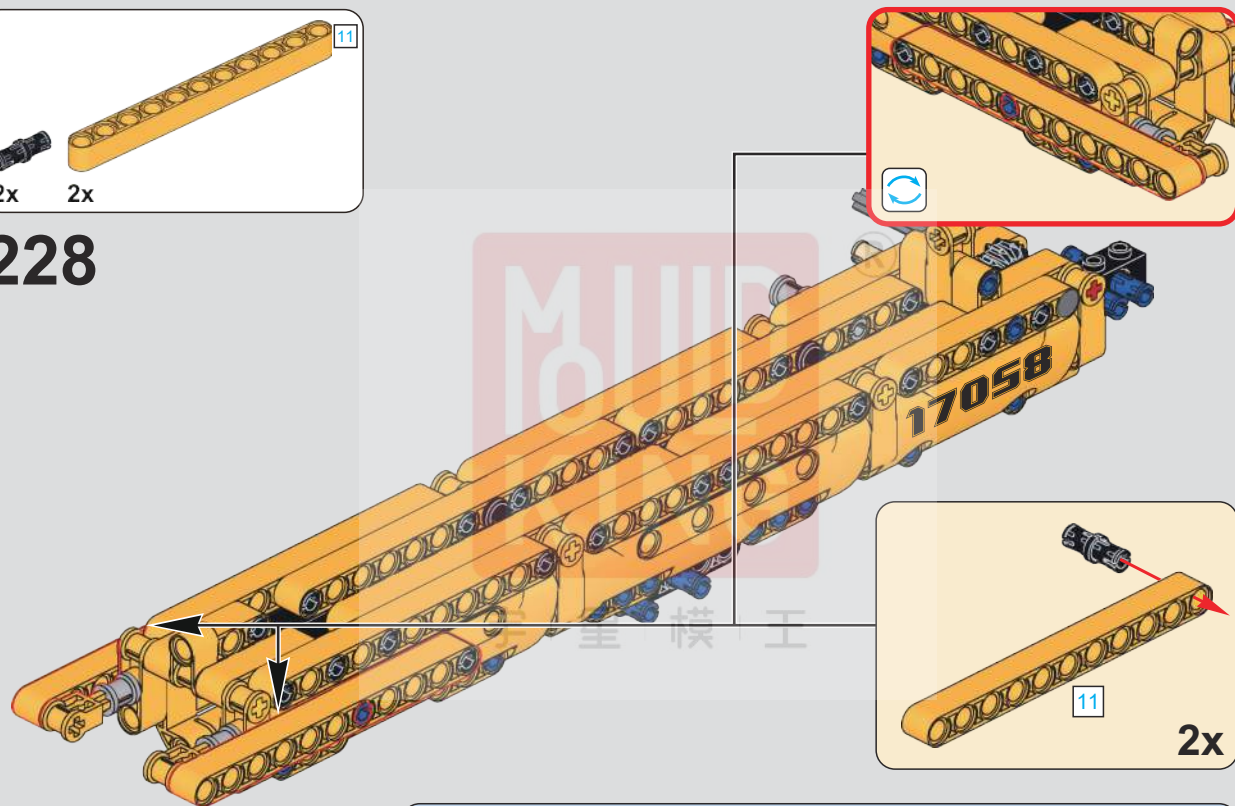



229

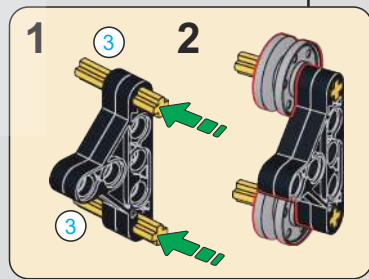
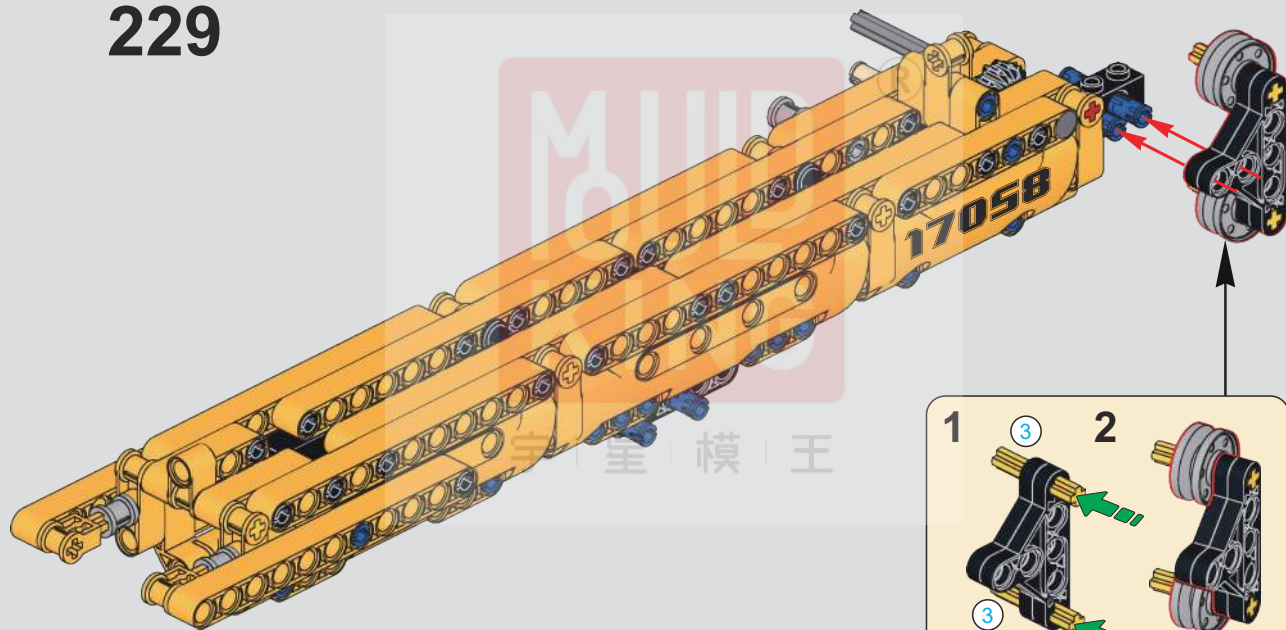
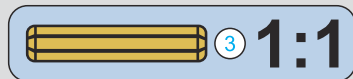



230

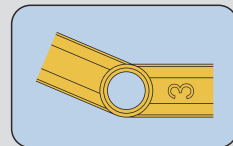
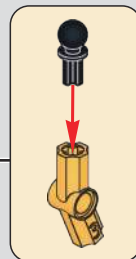



231

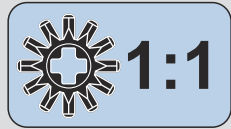

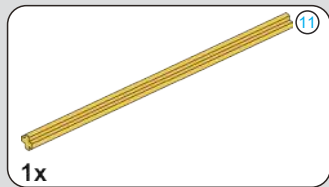

1x

232

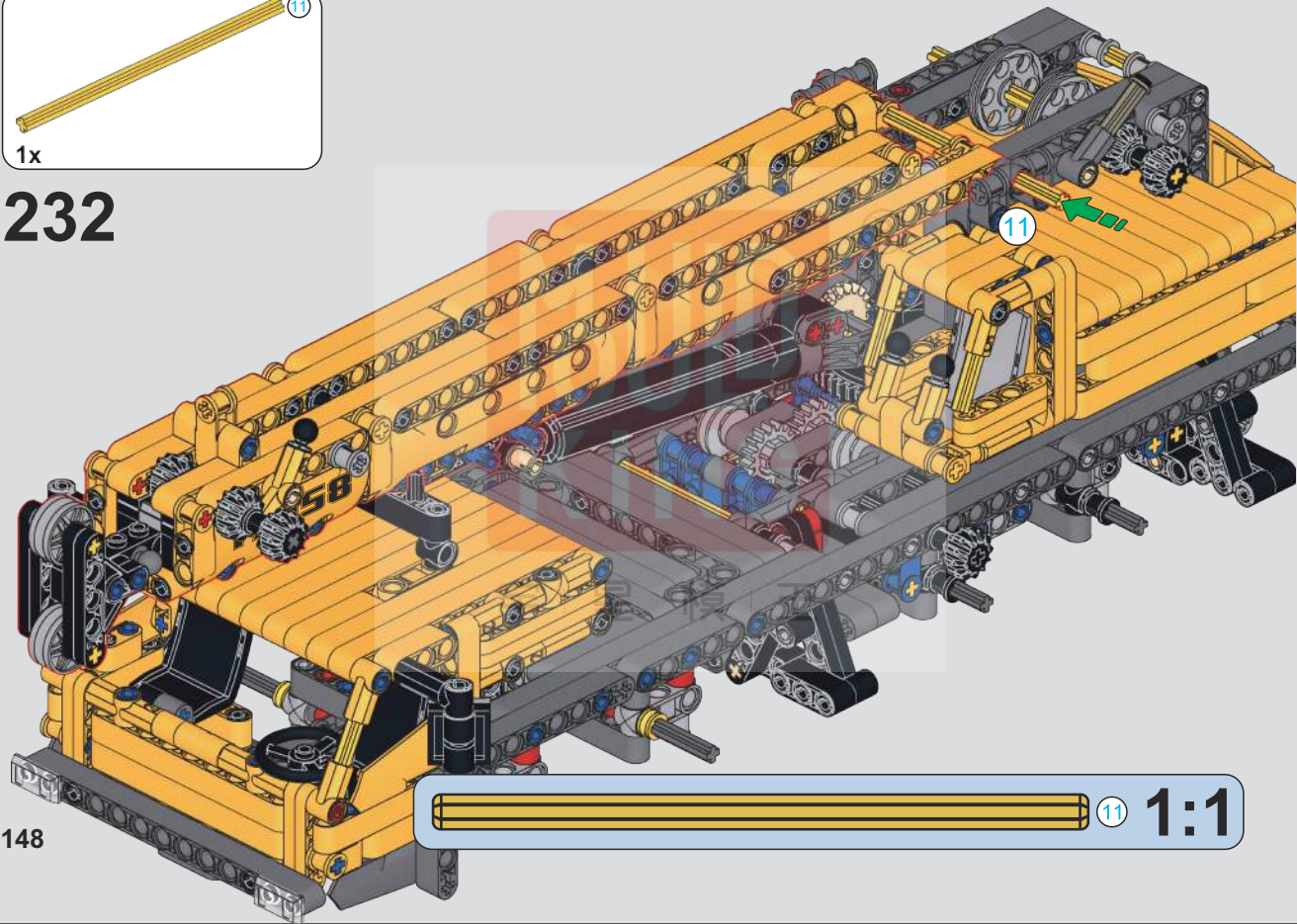

148

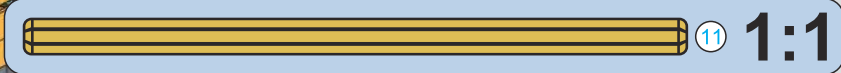

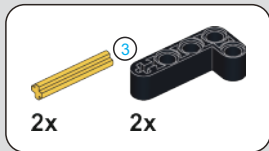

233

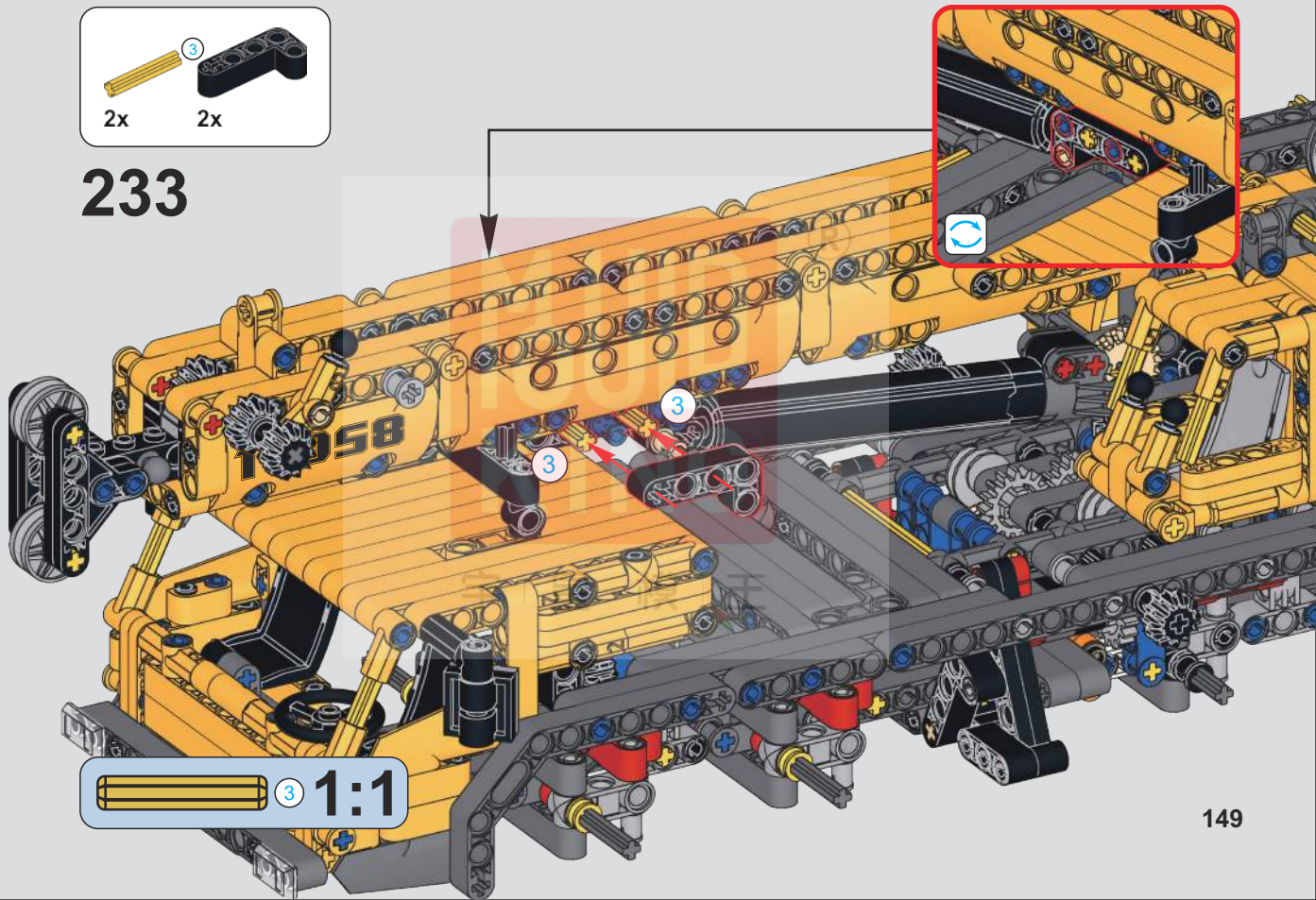

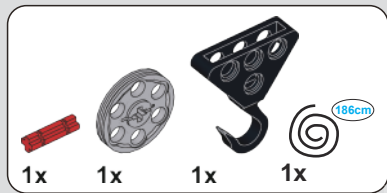

234

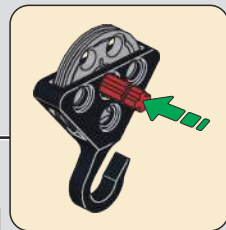
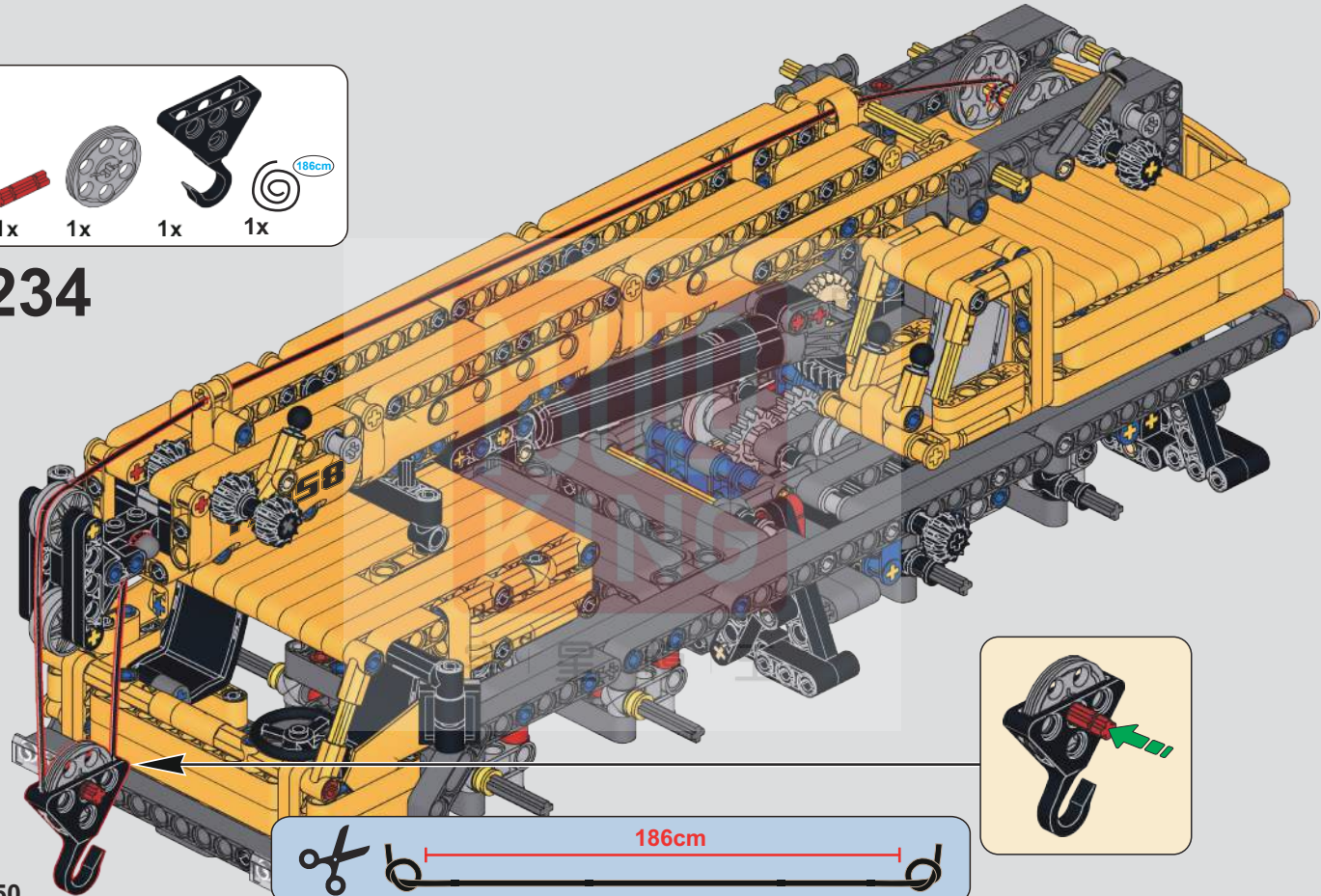

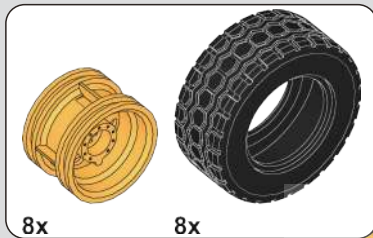

235

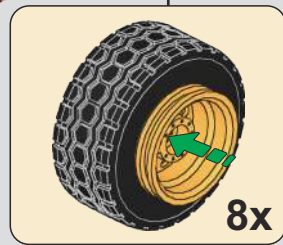
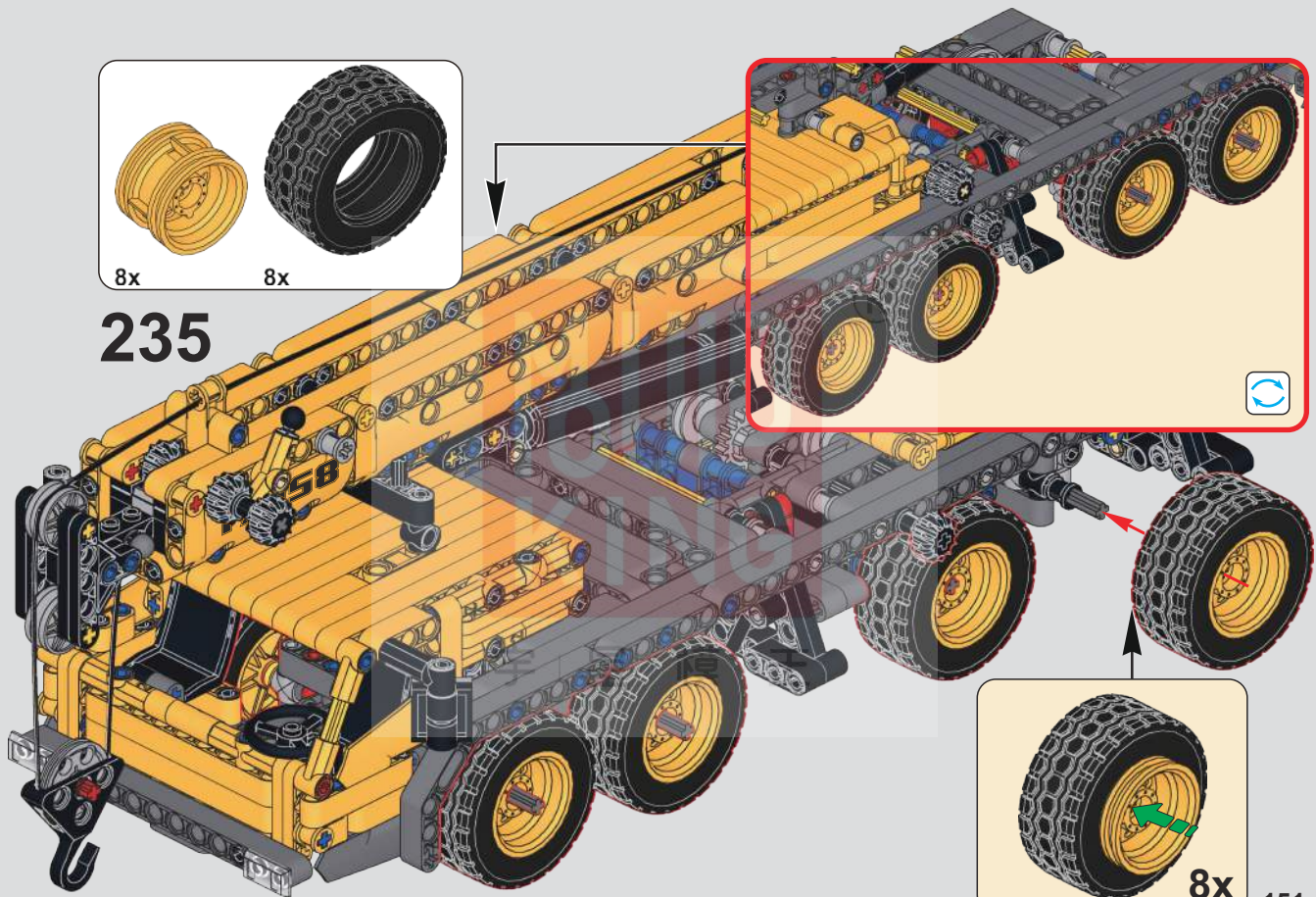
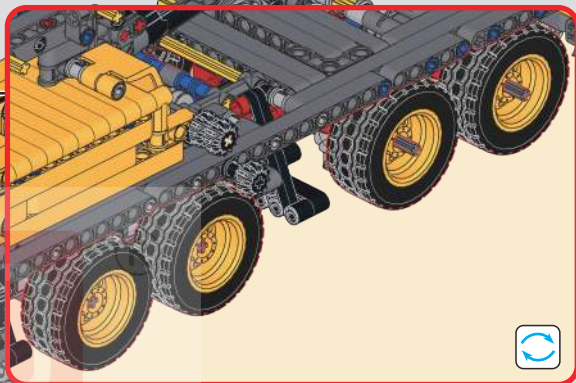



2x

236



237

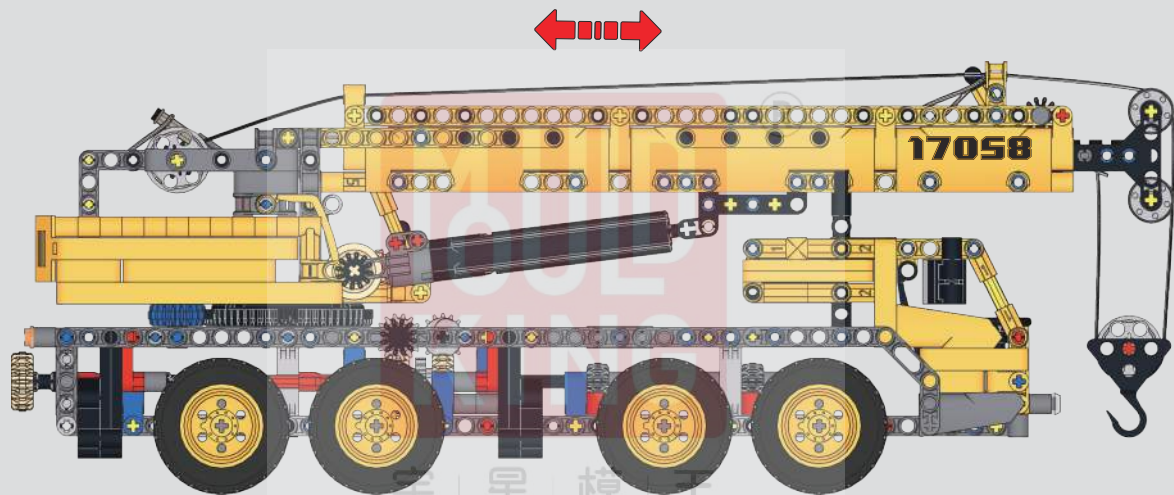

手动推动吊机前进和后退。
Manually push the crane forward and backward.

238

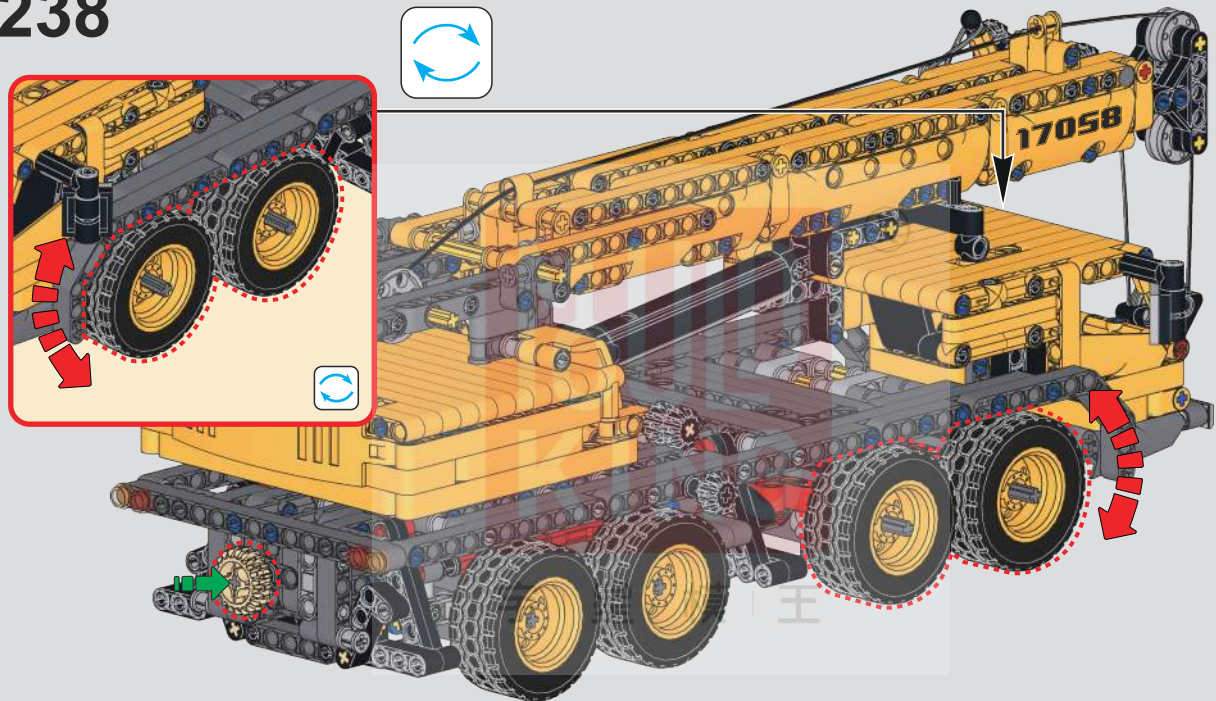

转动图示齿轮，控制前车轮左右转向。

Turn the illustrated gear to control the front wheel to turn left and right.

239

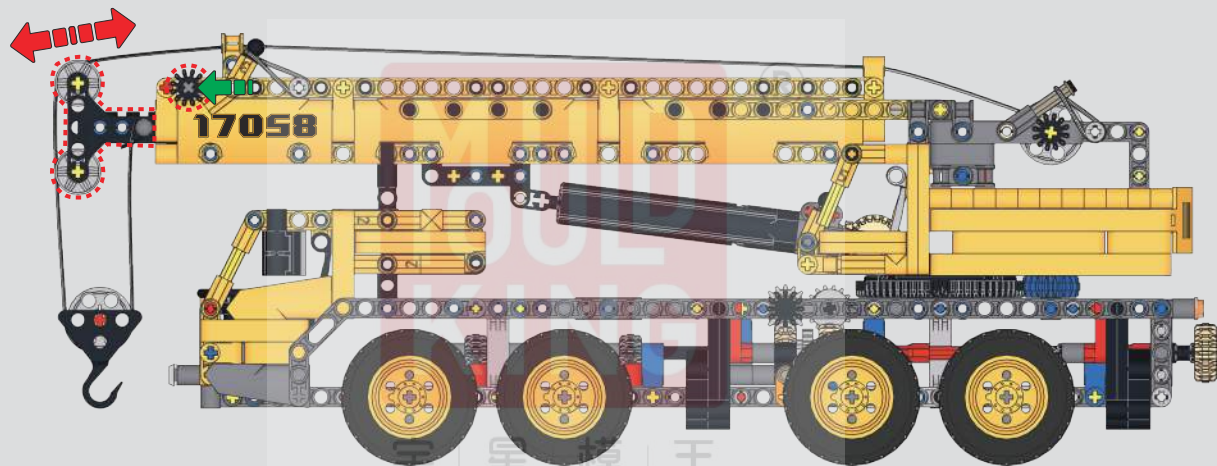

转动图示齿轮，控制吊臂伸缩。

Turn the illustrated gear to control the boom expansion and contraction.

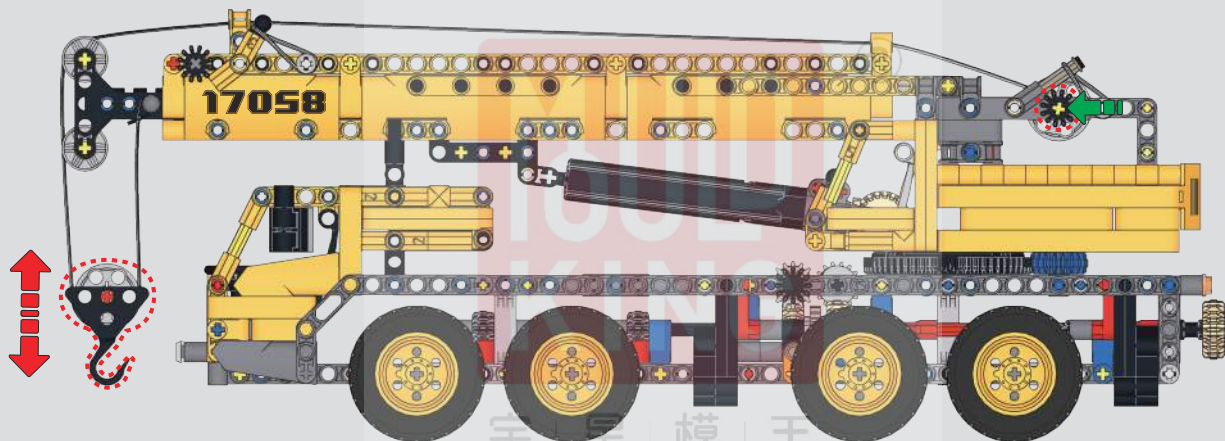

转动图示齿轮，控制起重钩收起放下。

Turn the illustrated gear to control the lifting hook.

241

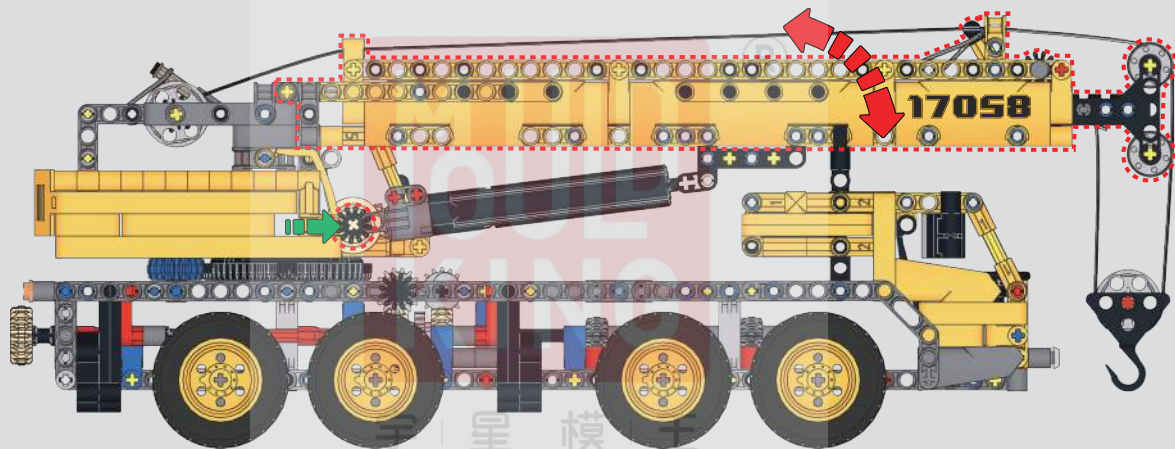

转动图示齿轮，控制起重臂升降。

Turn the illustrated gear to control the lifting of the boom.

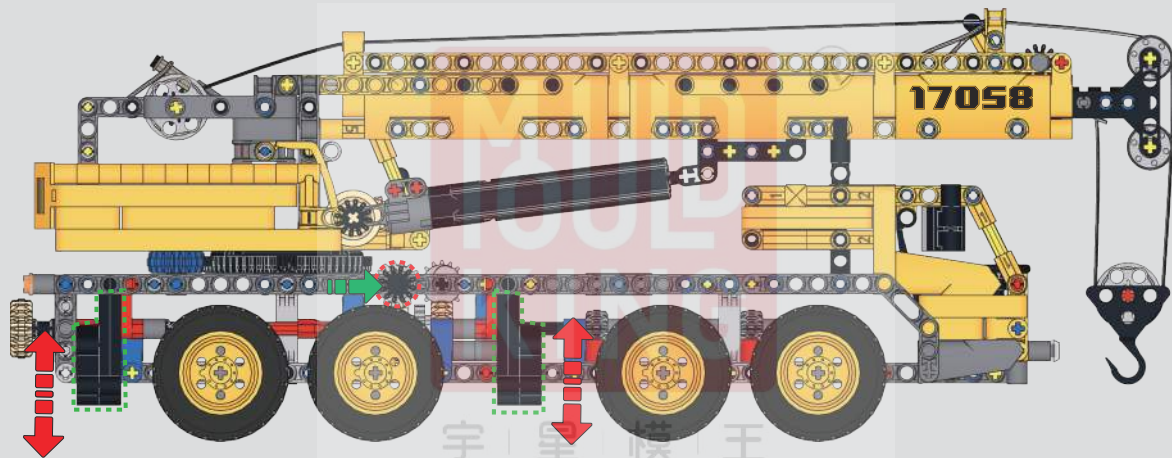

转动图示齿轮，控制支腿收放。

Turn the gear shown in the diagram to control the retraction of the legs.

243



手动转动起重机转盘旋转。

Manually turn the crane turntable to rotate.

244

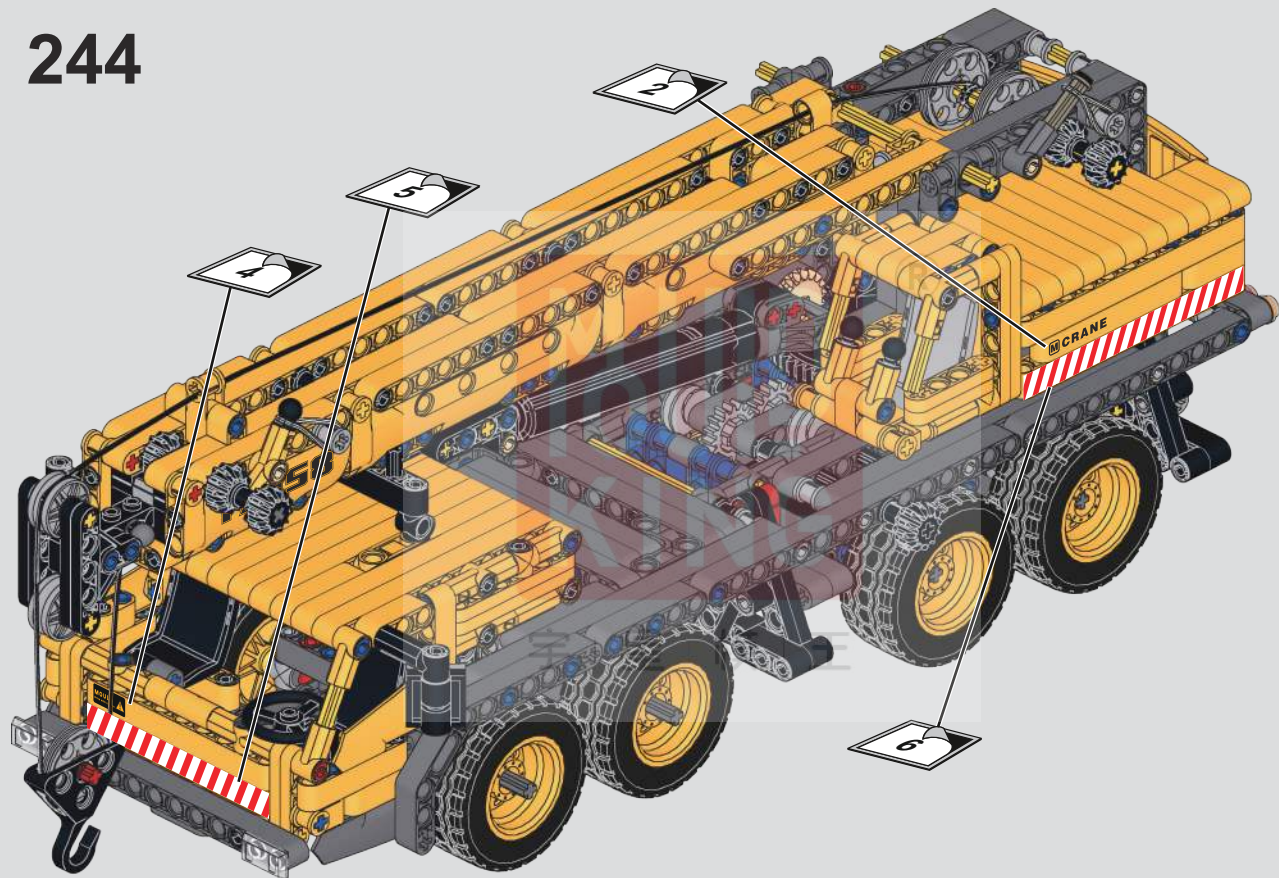

160

245

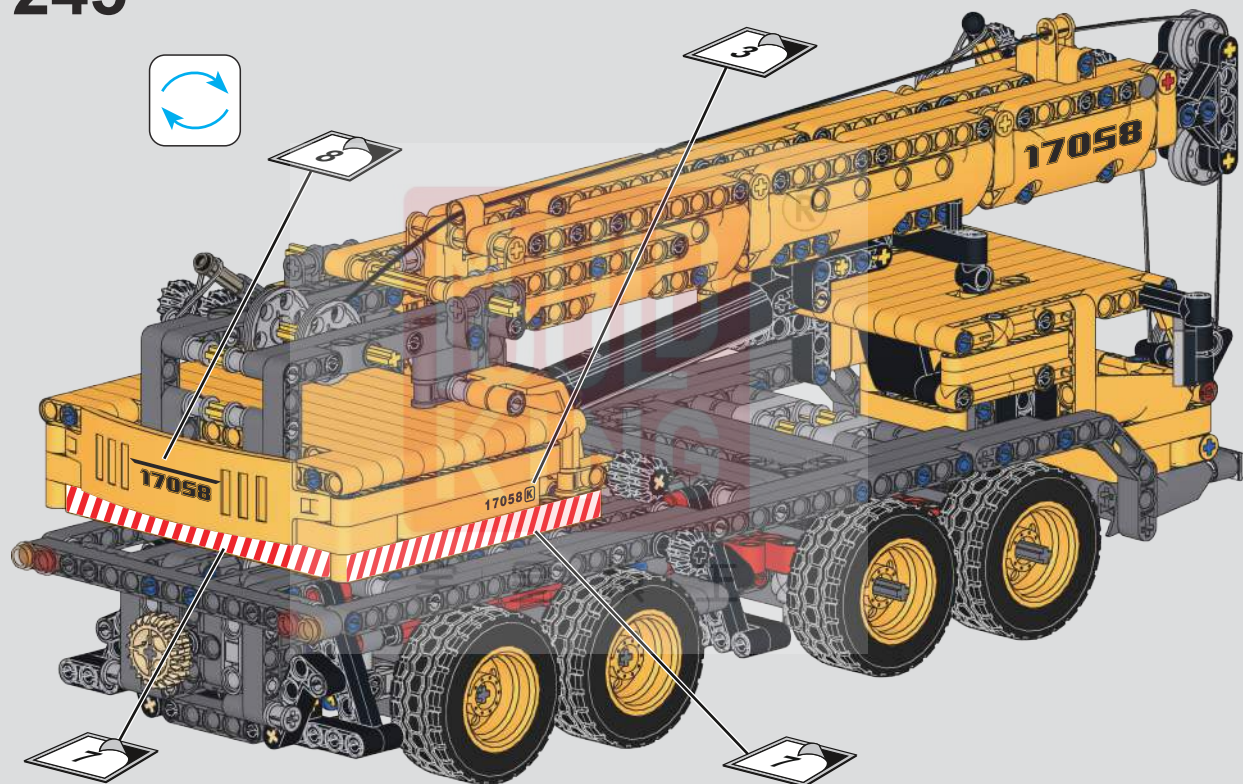

246



247



**MULD
KING**

®

宇 星 模 王

