

AIR FORCE

INTERCEPTER FIGHTER

Building blocks model
Perfect shape, high simulation, classic collection



6+ / 4004 / 223PCS
Suitable Age Product Number Parts Total

THIS PRODUCT DOES NOT CONTAIN BRACKET ACCESSORIES AND NEEDS TO BE PURCHASED SEPARATELY.

本品不含支架配件，需另外购买。

FLIGHT STAND

JX008

Perfect structure , easy assembly.

The Flight stand is compatible with our entire aircraft series.



EXTENDED GAMEPLAY



4001



CARRIER-BASED FIGHTER 1:54

4002



GUNSHIP 1:38

4003



HEAVY STEALTH FIGHTER 1:50

4004



INTERCEPTOR FIGHTER 1:48

4005



SR-71 BLACKBIRD 1:74

4006



P-51 MUSTANG FIGHTER 1:26

5005



AIRBORNE EARLY WARNING AND CONTROL AIRCRAFT 1:100

5006



TILTROTOR AIRCRAFT 1:44



微信扫一扫
补件更简单

Schematic diagram of the F15 Eagle fighter-1

Brief introduction

F-15 Eagle is a twin-engine, all-weather tactical fighter designed to gain and maintain air superiority in aerial combat. It is considered as one of the most successful modern fighters. The design proved flexible enough that an all-weather 24 hours strike derivative, and could using the AMRAAM to destroy the enemy.

General characteristics

Crew: 1: pilot
Length: 19.43 m
Height: 5.68 m
Wingspan: 13.03 m
Empty weight: 12,973 kg
Max. takeoff weight: 30,800 kg
Fuel capacity: 6,103 kg internal

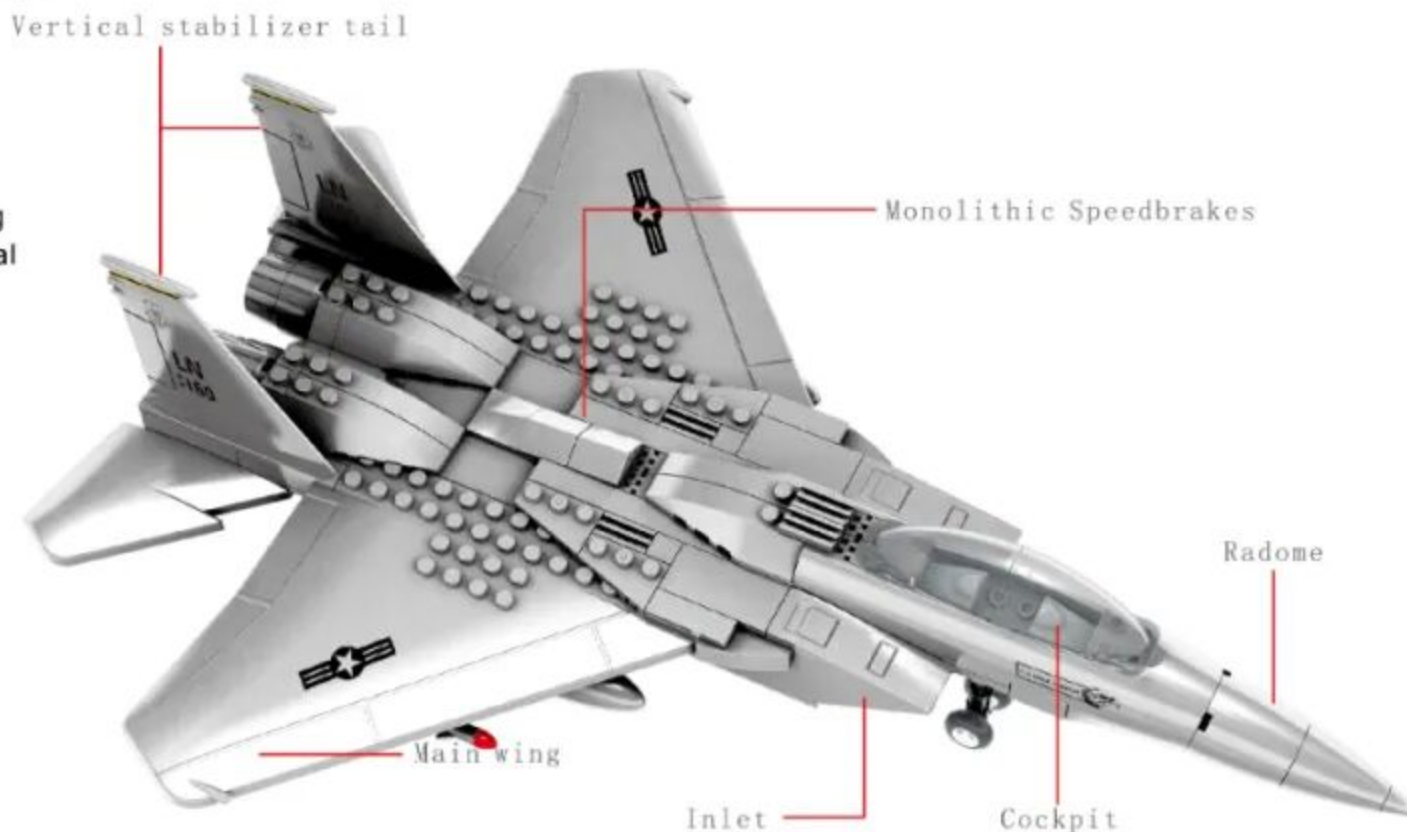

Schematic diagram of the F15 Eagle fighter-2

Performance

Maximum speed: Mach 2.5+
Service ceiling: 19,800 m
Rate of climb: >15240 m/min.

Armament

Guns: 1× 20 mm M61 Vulcan 6-barreled
Gatling cannon, 940 rounds

Missiles:

AIM-7 Sparrow
AIM-120 AMRAAM
AIM-9 Sidewinder

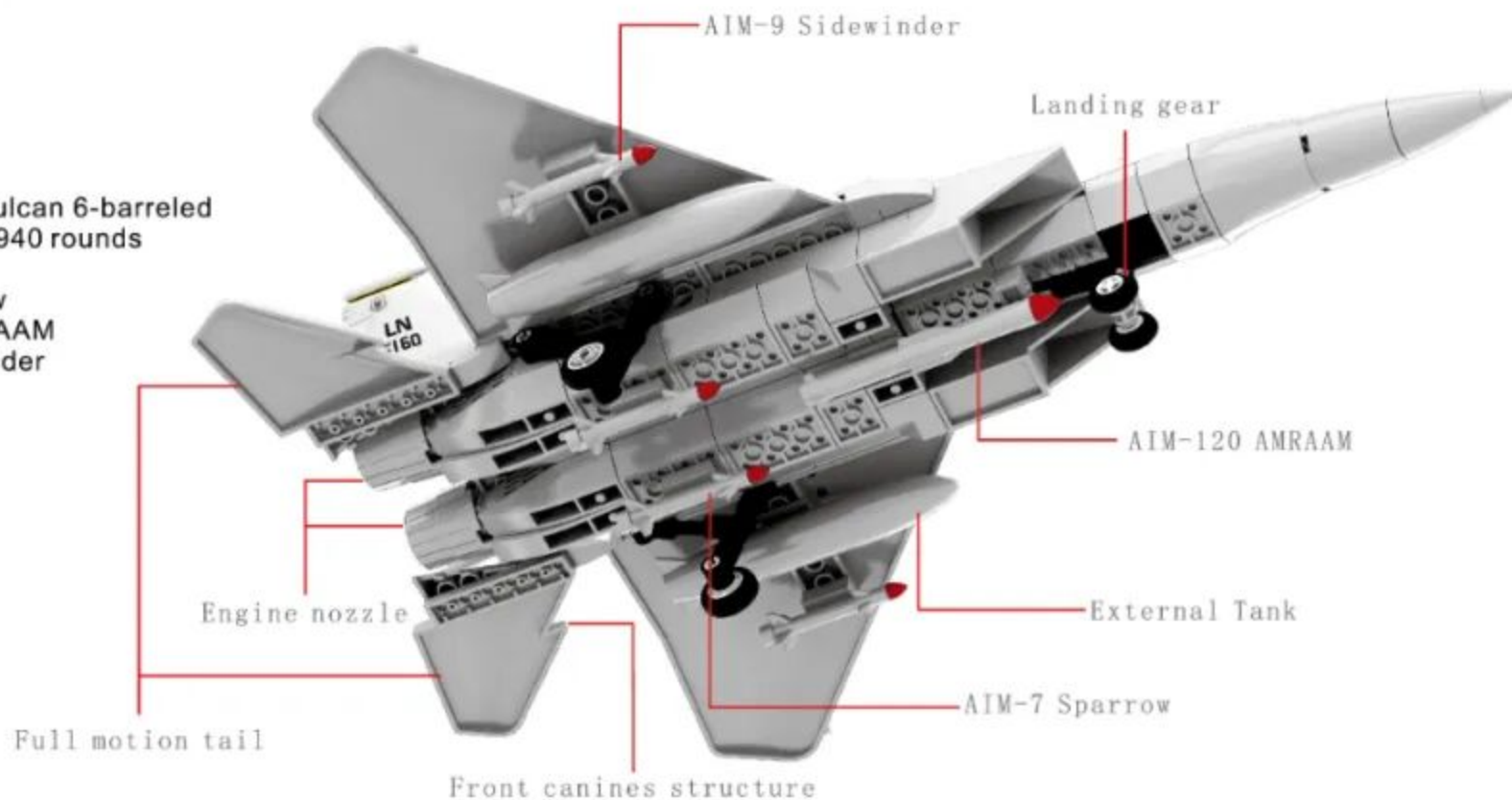

PARTS LIST

配件清单



x1



x1



x1



x1



x2



x1



x2



x2

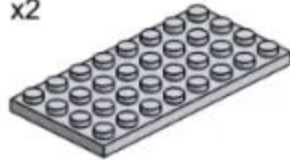

x1



x2

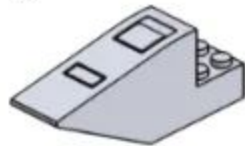

x2



x1



x1



x2



x2



x2

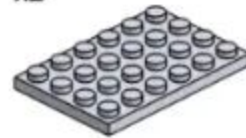

x2



x2



x2



x3



x3



x6



x1



x2



x2



x4



x1



x2



x2



x1



x1



x3

PARTS LIST

配件清单



x6



x2



x6

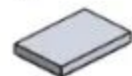

x3



x4



x2



x2



x1



x2



x2



x1



x2



x2



x2



x2



x4



x2



x2



x2



x2



x4



x2



x1



x1



x1



x2



x1



x6



x7



x2



x1



x5



x2



x4



x4



x1



x2



x2



x1

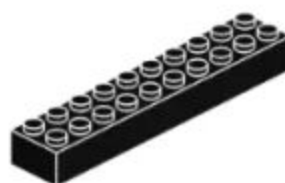

x1



x1



x1



x2



x3



x1



x5



x1



x2



x3



x5



x2



x2



x2



x9



x1



x2



x2



x2



x6



x2



x2



x1



x4

产品有增补件请以实物为准

If product has additional parts, please in kind prevail.

1-1

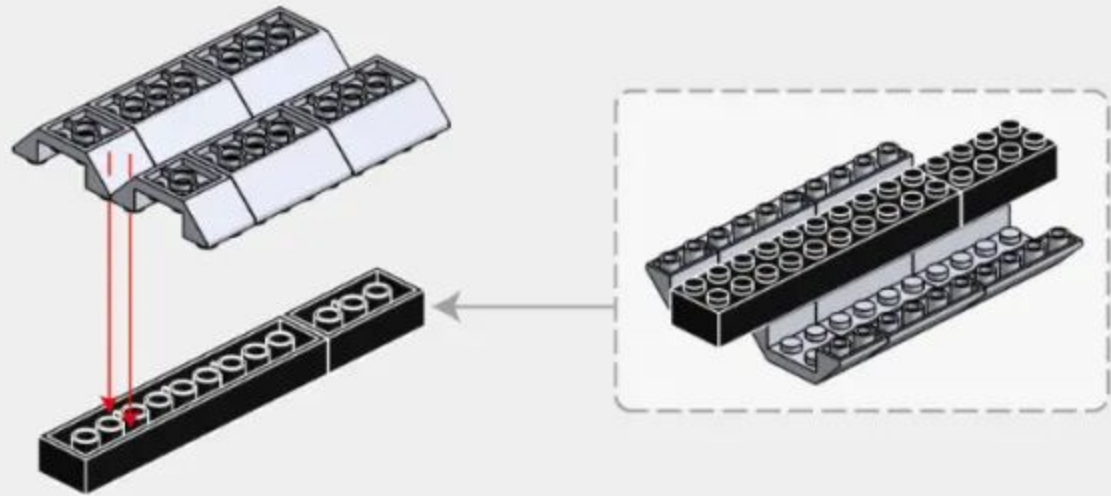
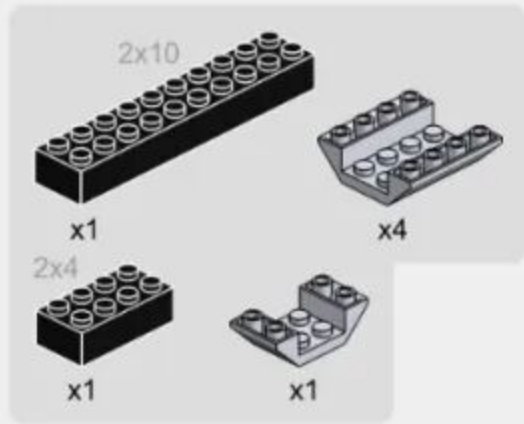

1-2

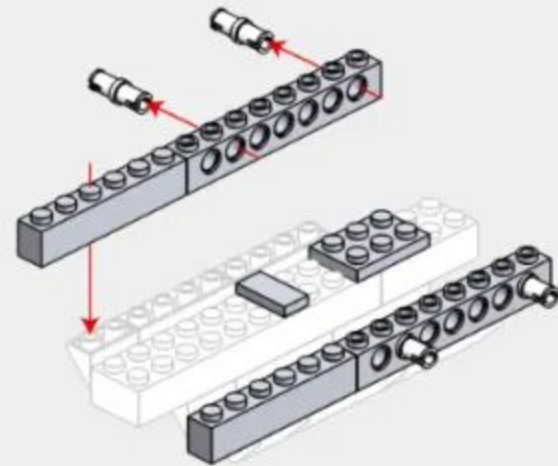
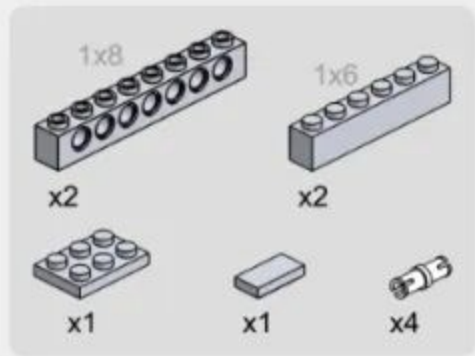

1-3

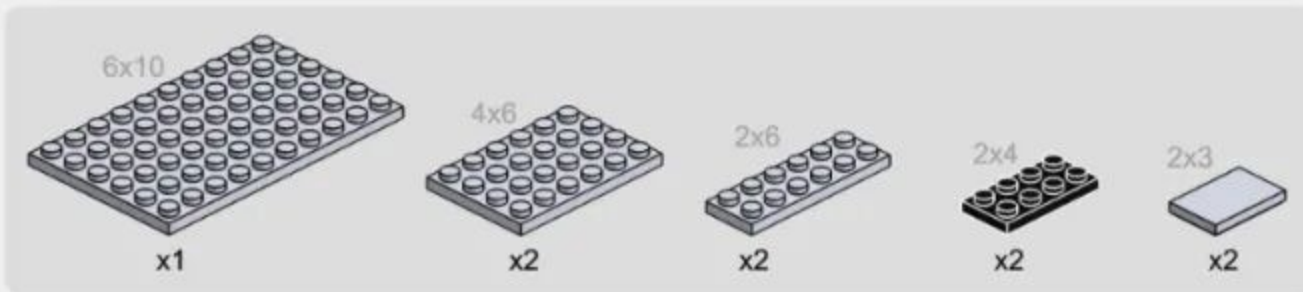

1

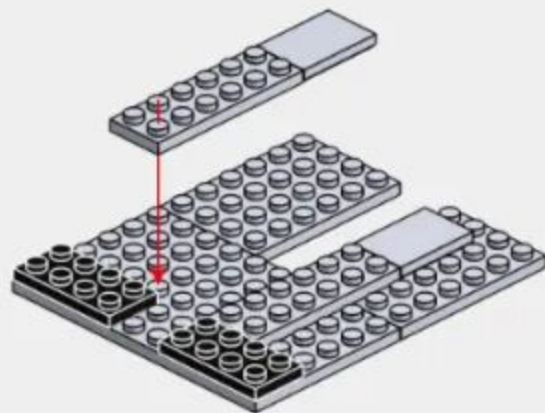

2

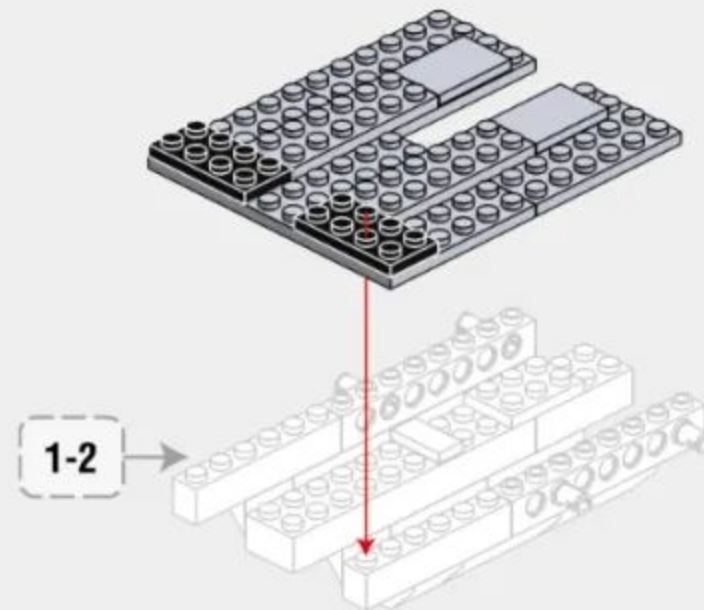

1-4

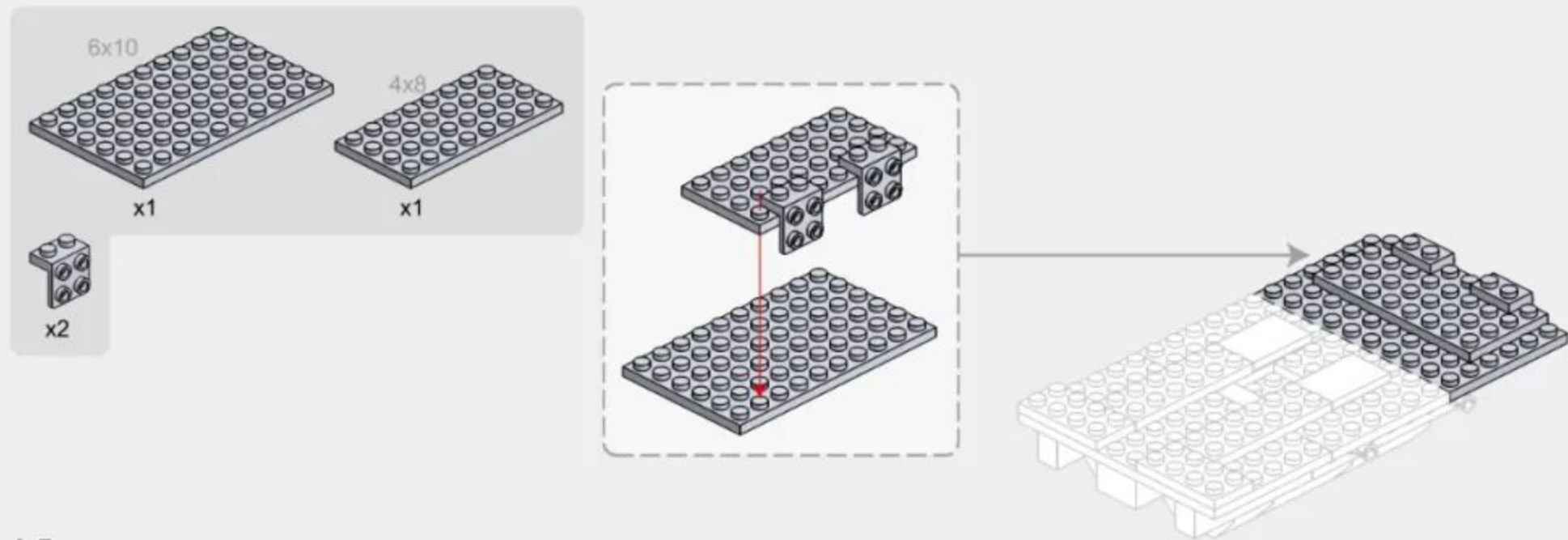

1-5

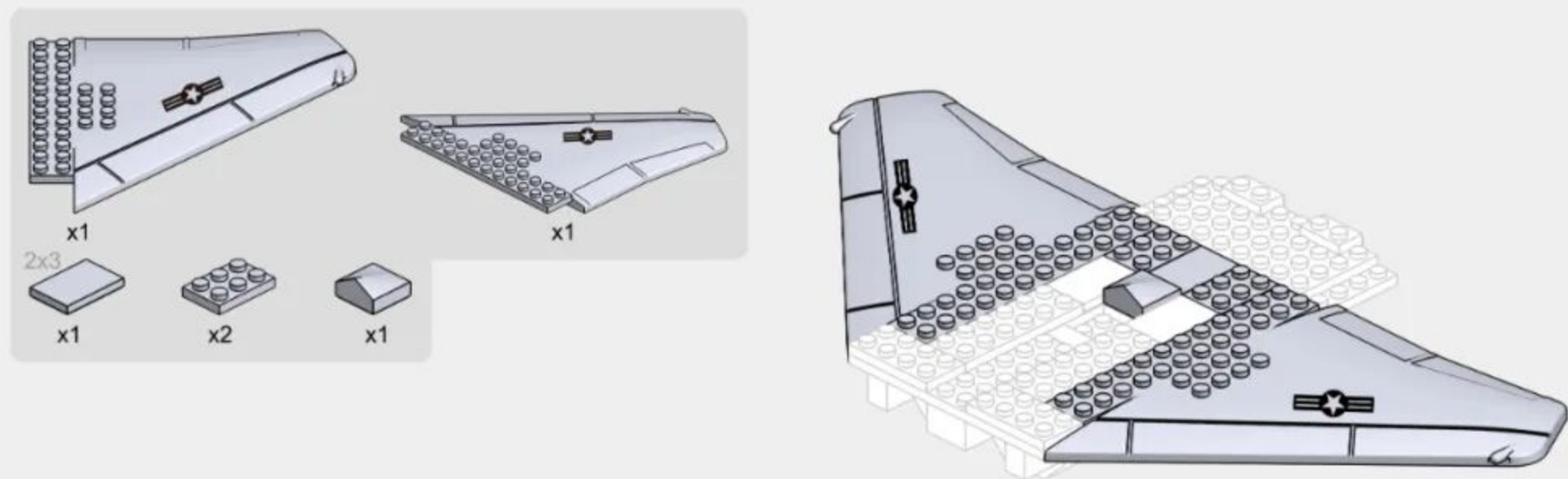

1-6

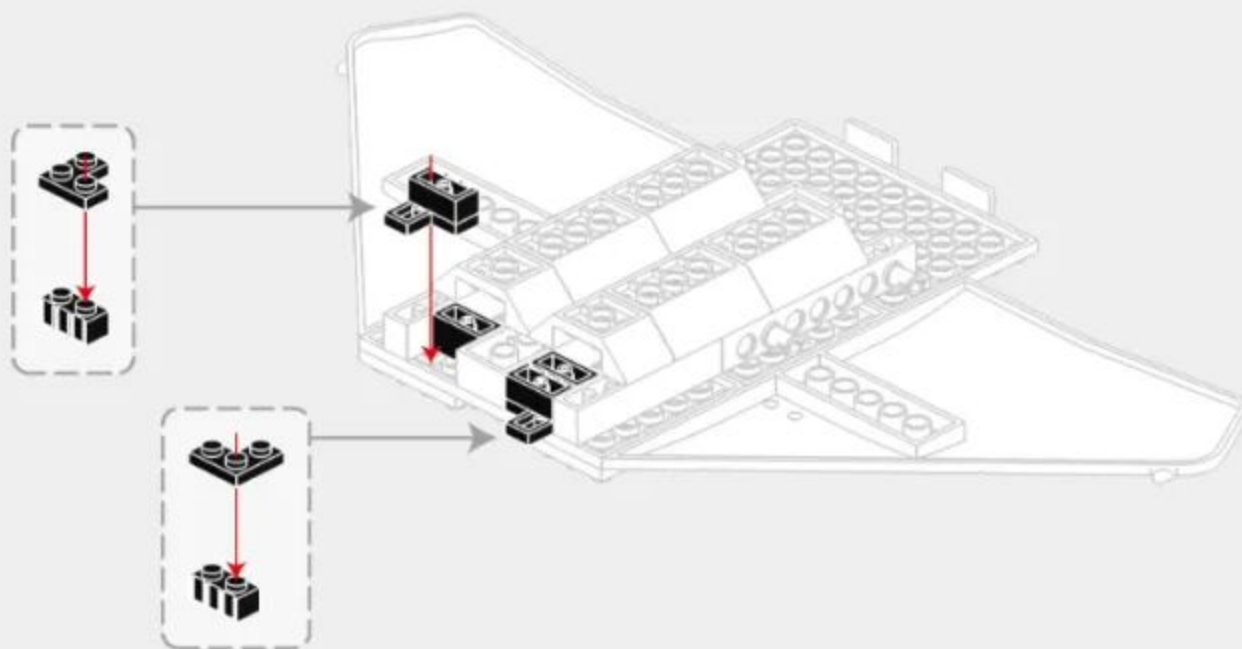

1-7

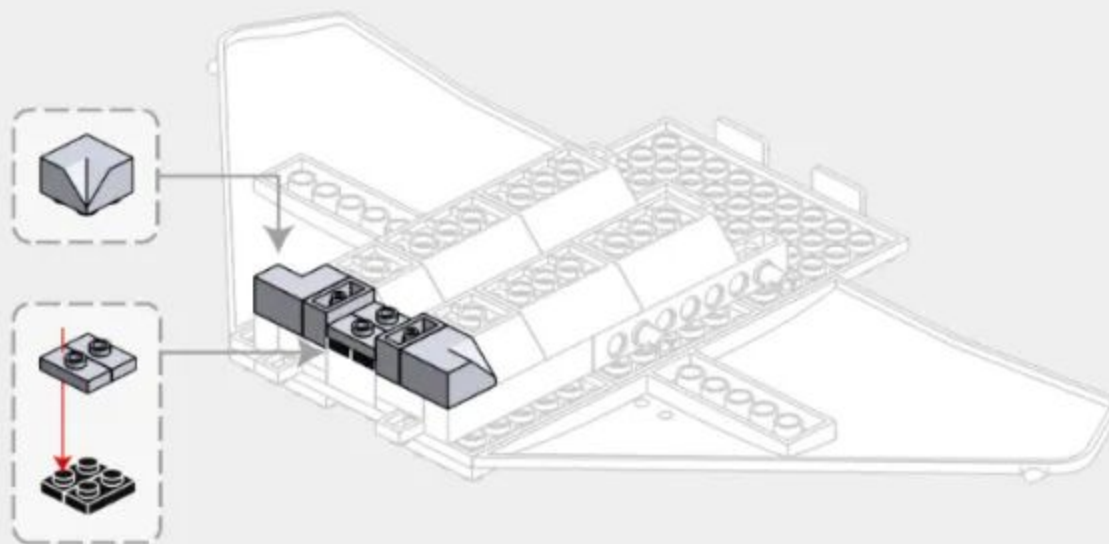

1-8

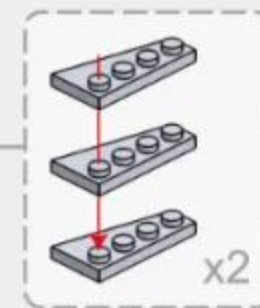
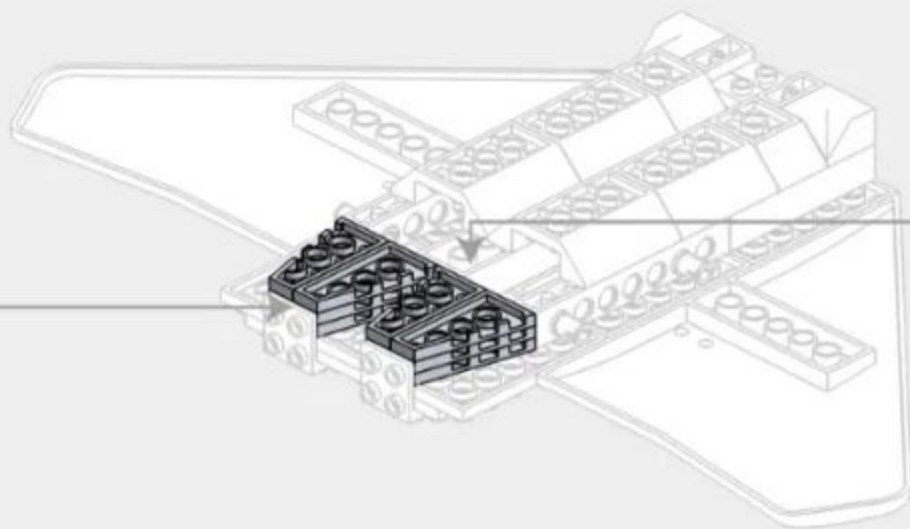
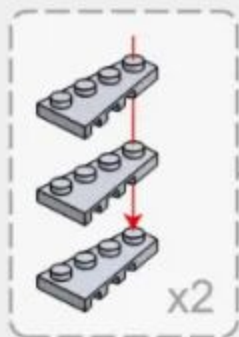
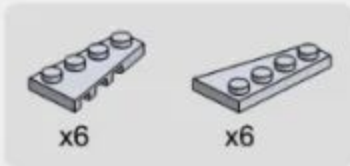

1-9

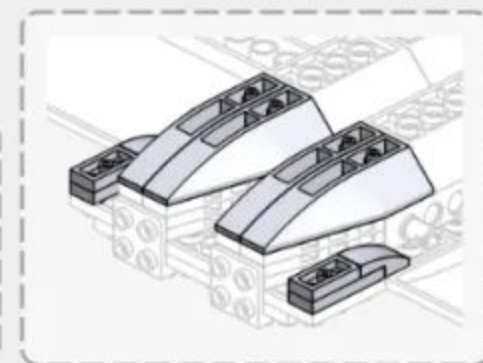
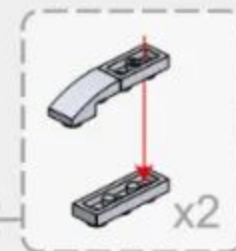
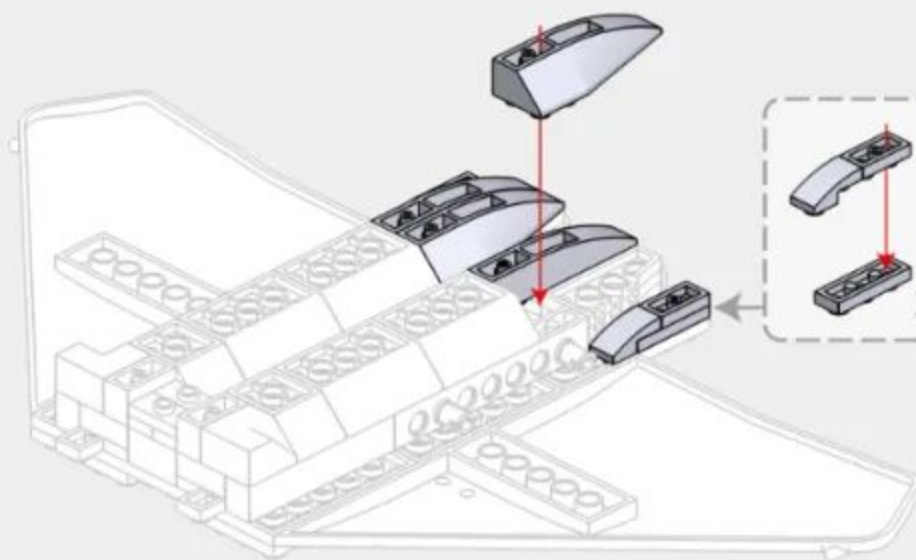
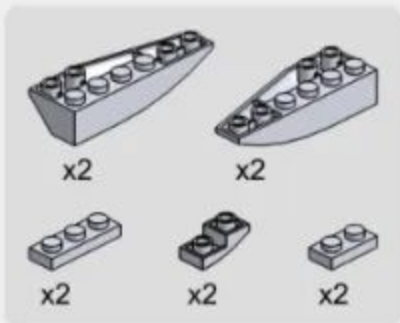

1-12

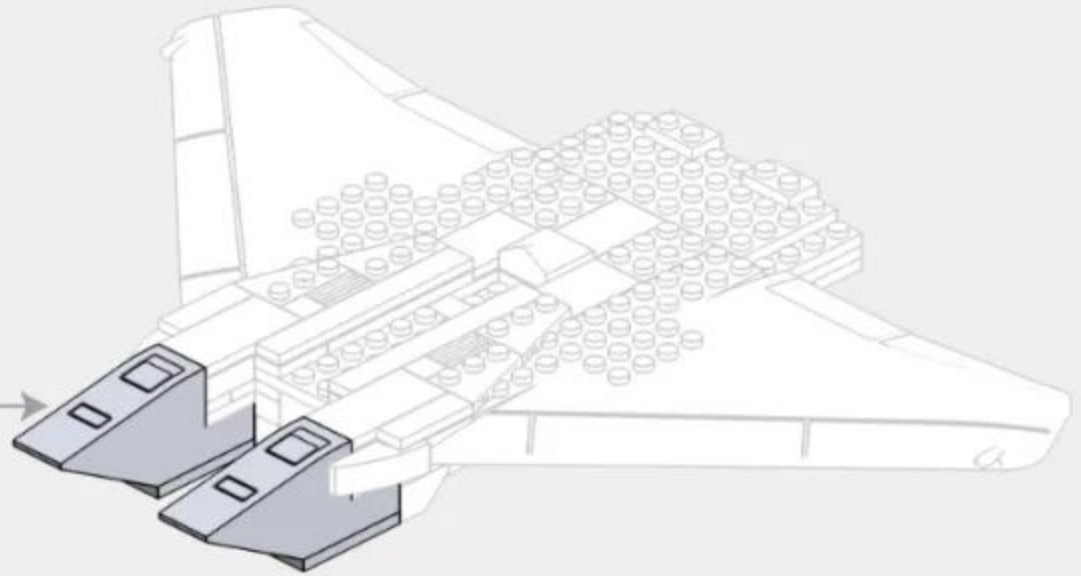
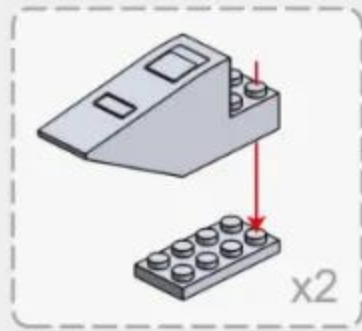
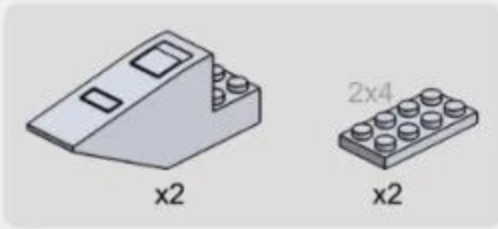

1-13

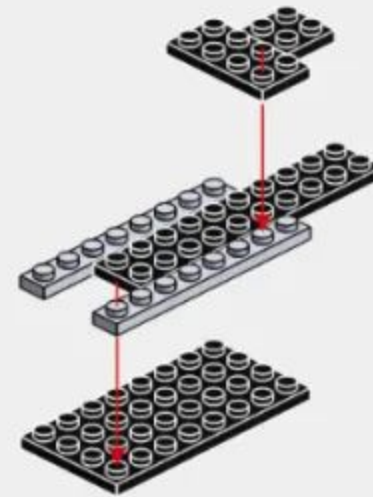
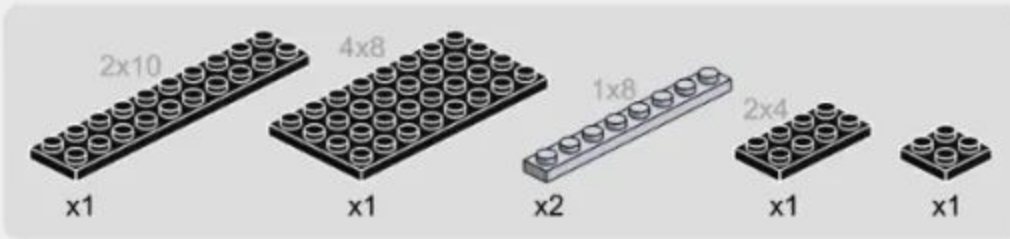

1-14

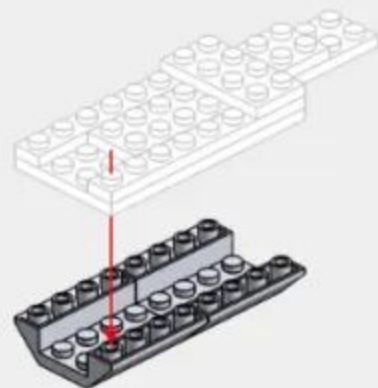

1-15

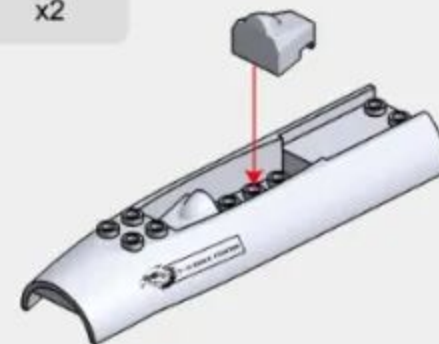

1-16

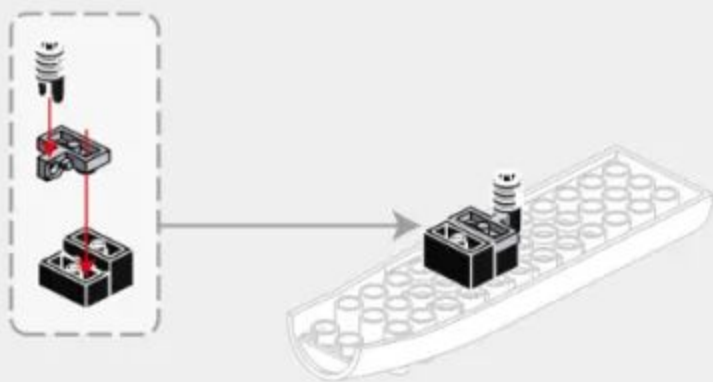

1-17

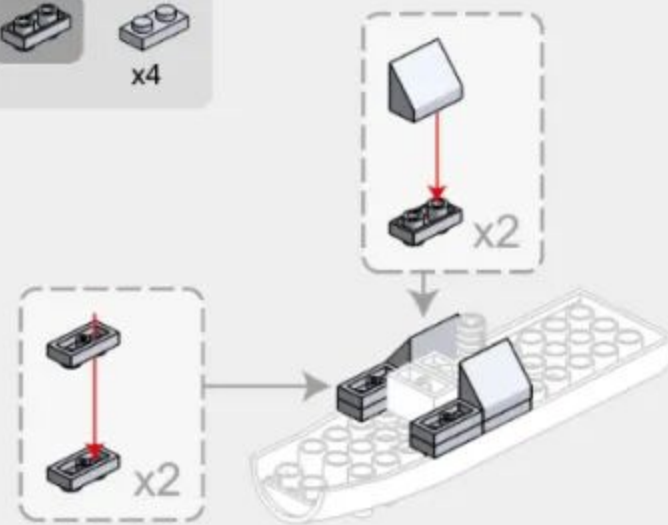

1-18

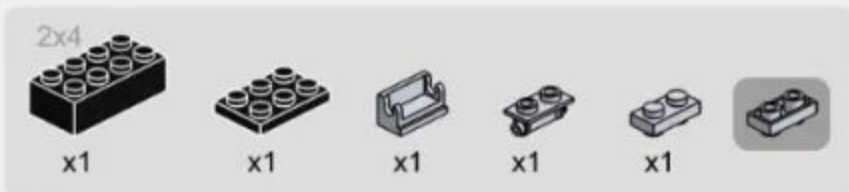

1-19

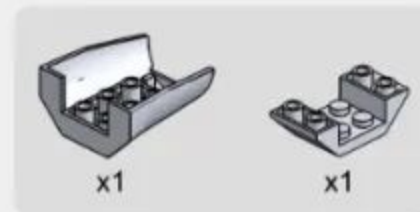

1-20

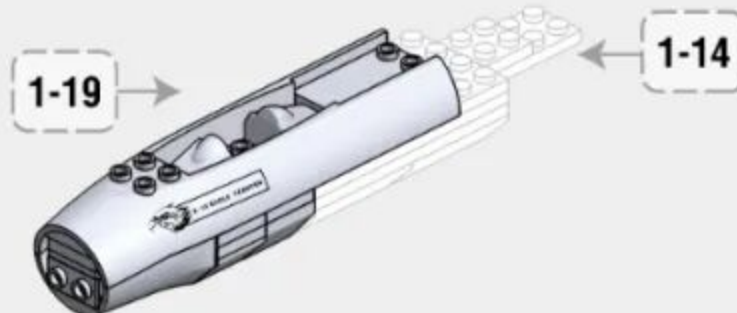
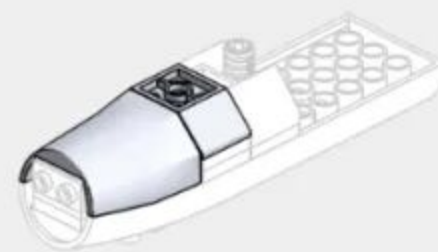
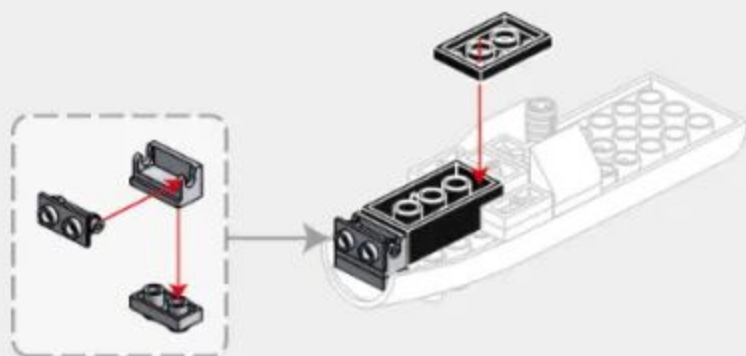

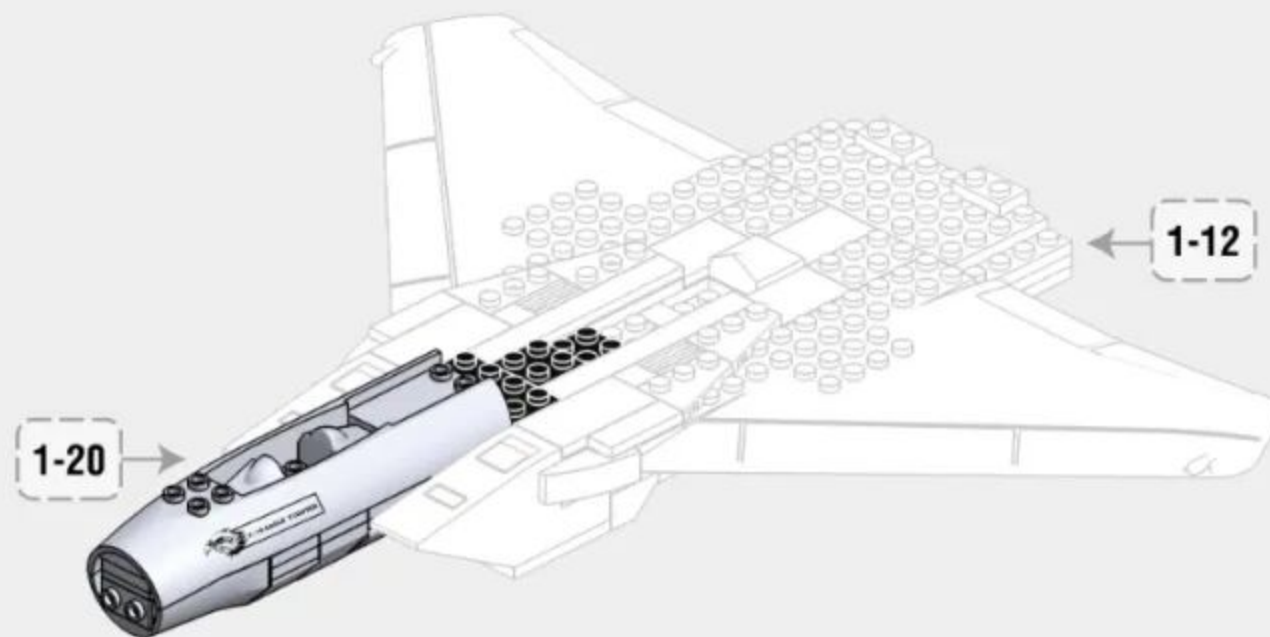

1-22

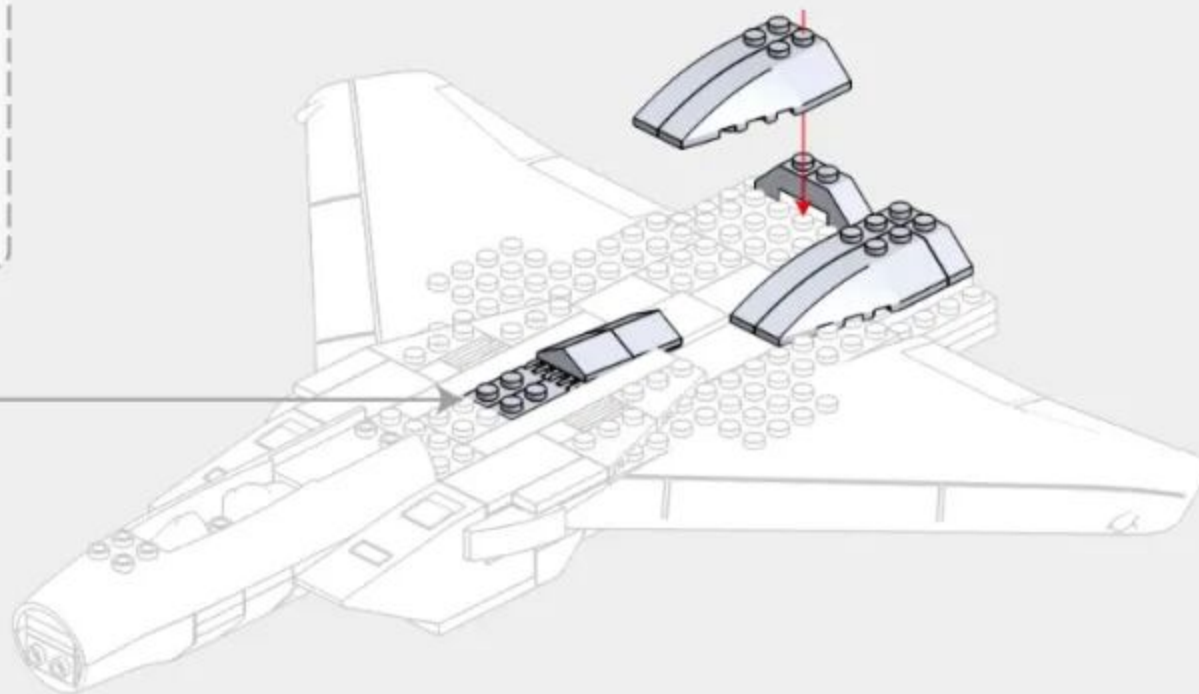
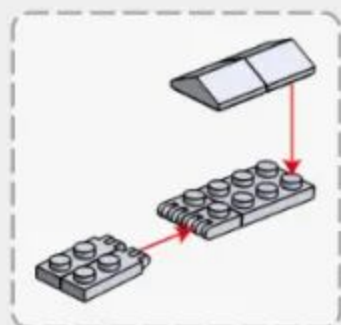
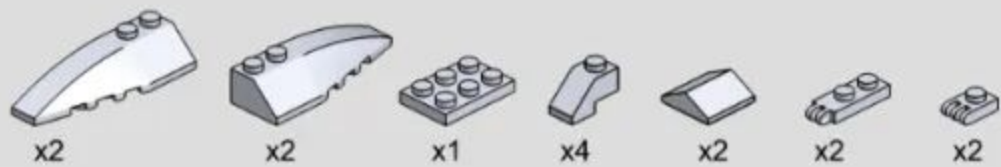

1-23

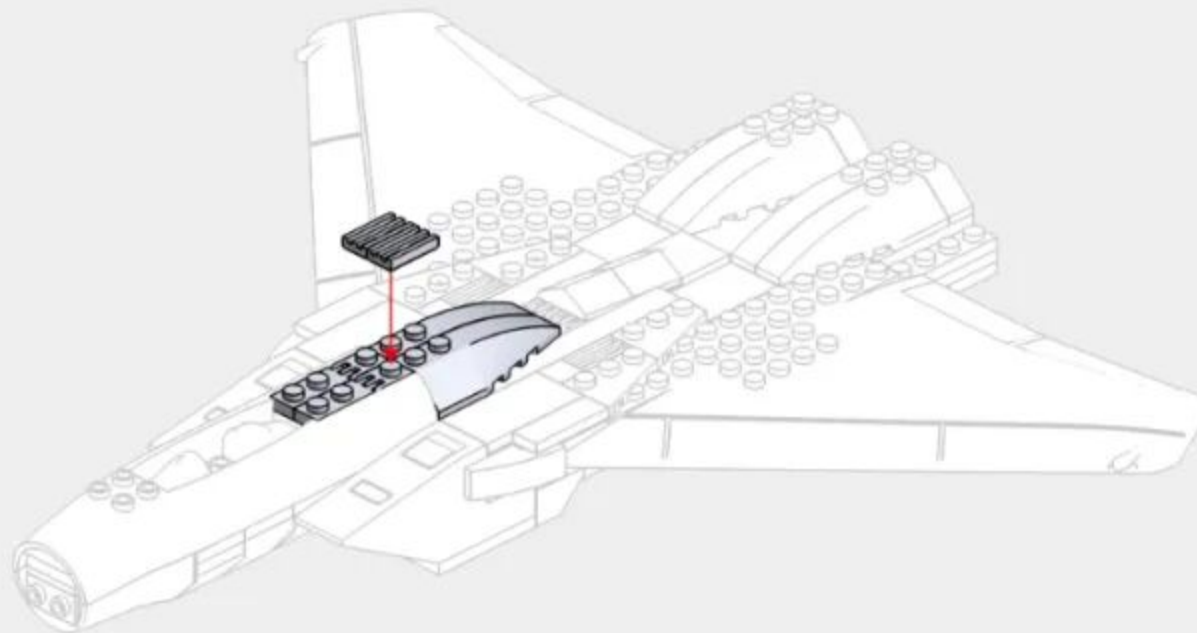
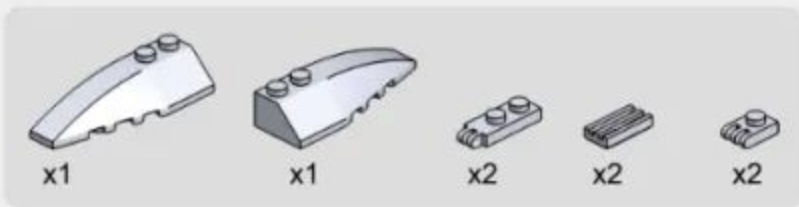

1-24



x2



x1



x1



x1



x1

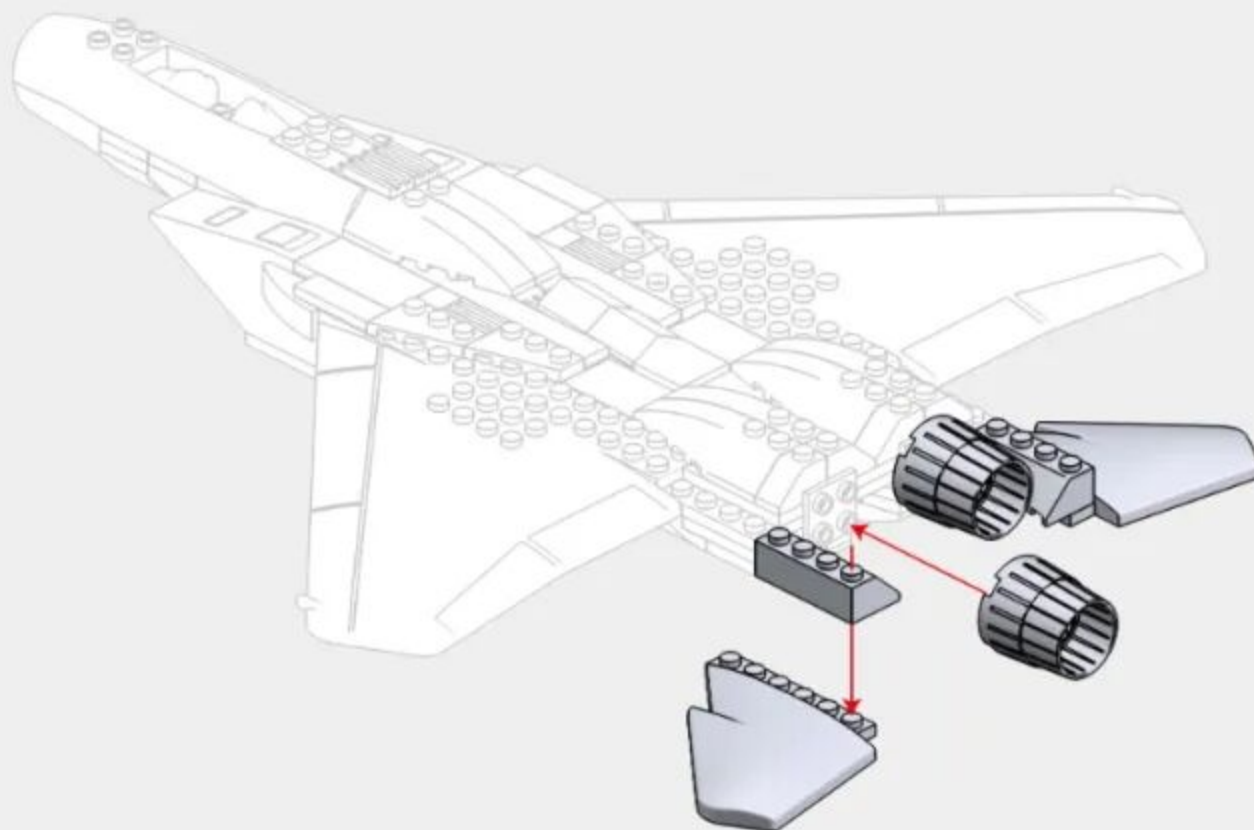

1-25



x2

4



x4



x2



x8



x2

1:1



4

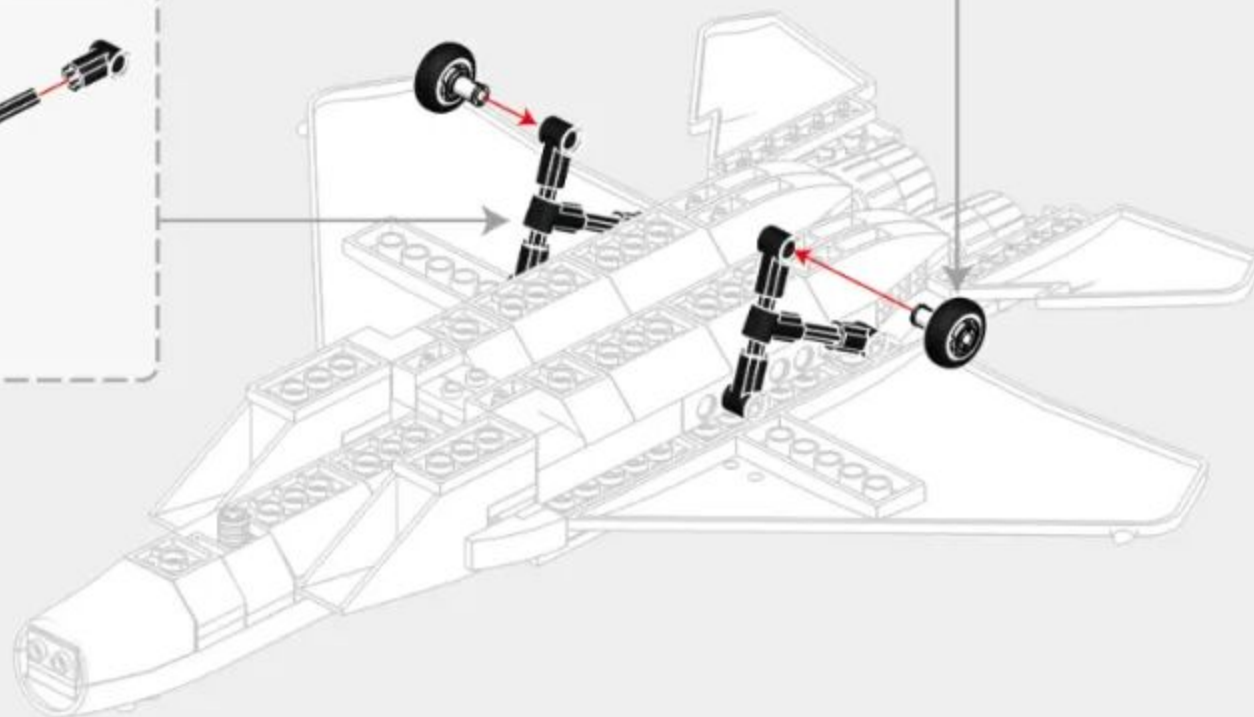
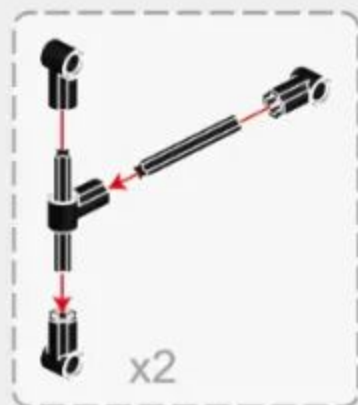

1-26

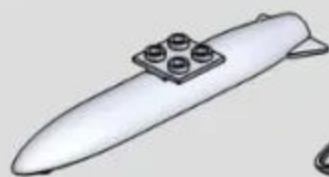

x2



x2



x4



x4



x4



x4

1



2



x4



x2

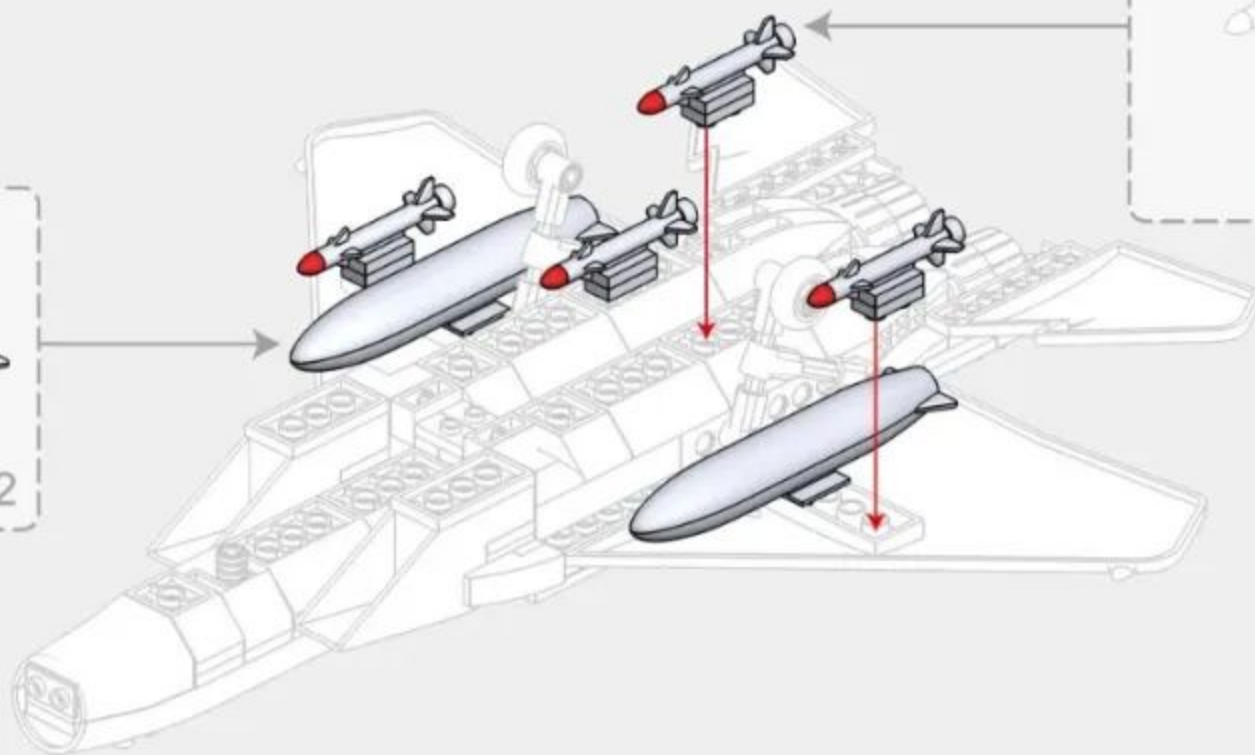

1-27

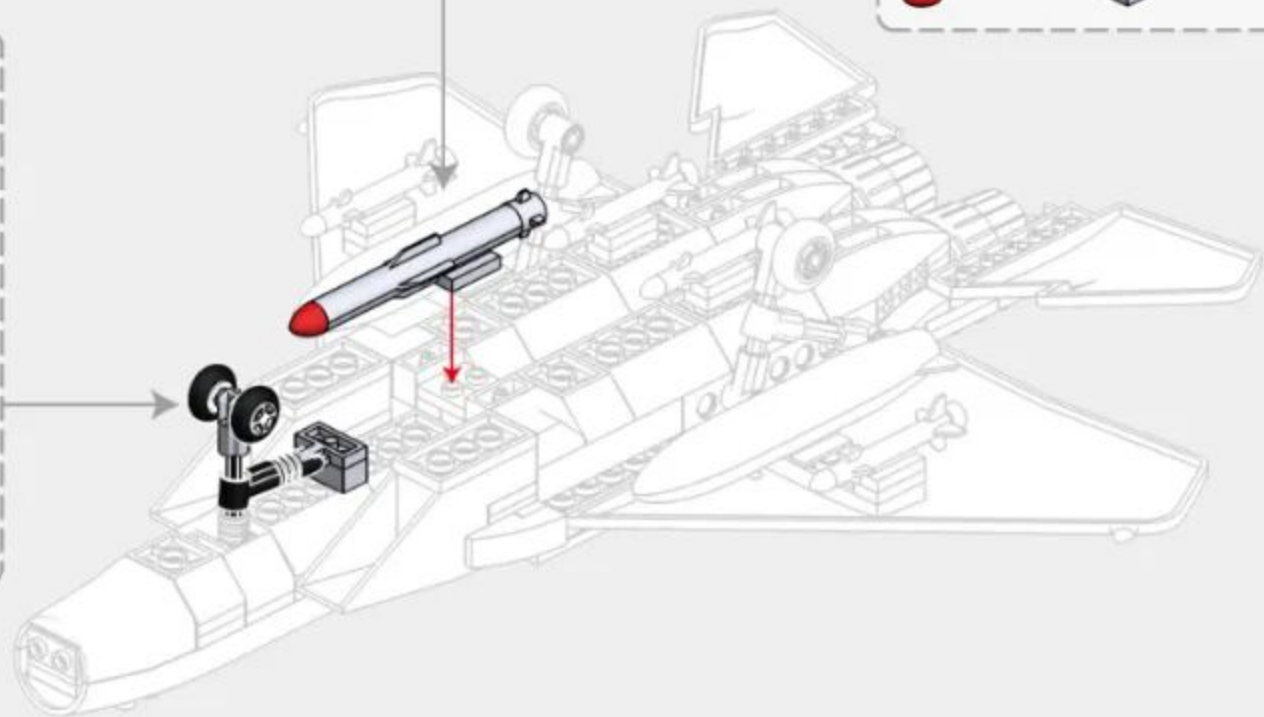
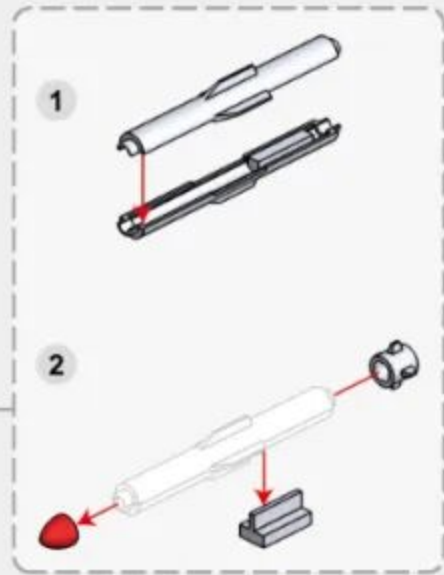

1-28

