



# TREVI FOUNTAIN

FONTANA DI TREV

Roman, Italy

The world's great architecture



- Creative Ability
- Family Interaction
- Observation Ability
- Thinking Ability
- Practical Ability

6+ / 4212 / 650 PCS  
Suitable Age / Product Number / Parts Total



# Architecture

It will be a city...

这将构成一座城市...

# ABOUT THE PRODUCT

关于产品

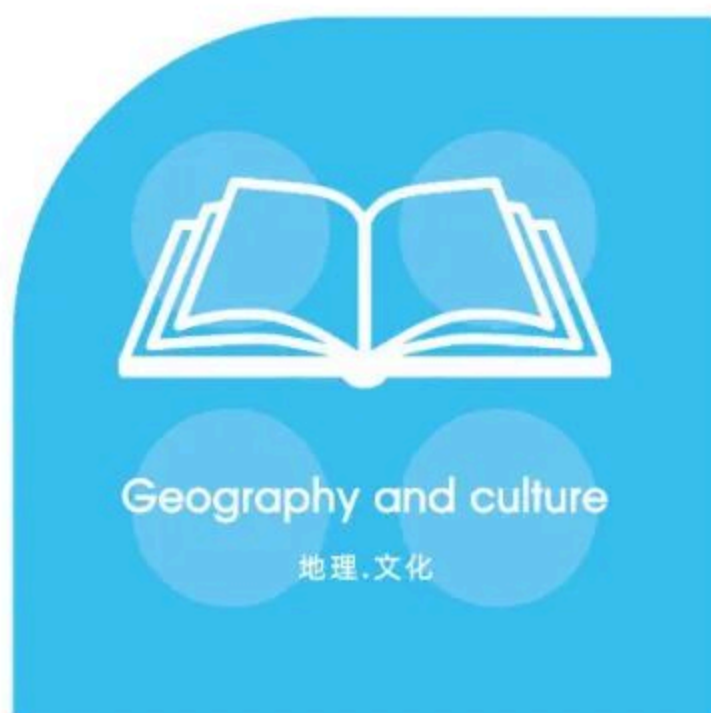

## ARCHITECTURE

WANGE The world's great architect since 1991

# Trevi Fountain



The Trevi Fountain is an 18th-century fountain in the Trevi district in Rome, Italy, designed by Italian architect Nicola Salvi and completed by Giuseppe Pannini in 1762 and several others.

# Trevi Fountain



## Geography and culture

地理·文化



At 26.3 metres (86 ft) high and 49.15 metres (161.3 ft) wide, the Trevi Fountain is the largest Baroque fountain in the city and one of the most famous fountains in the world.





意大利罗马许愿池

# Trevi ■ Fountain Italy

The contents of this chapter refer to the Wikipedia website.

本章内容参考维基百科网站，更多资讯可自行查阅。

The world's great architecture

# Buildings and layout

■ 建筑物和布局



Trevi Fountain, located in Rome, Italy, is a Baroque-style fountain built on the façade of Palazzo Poli. Its center features a statue of Neptune, the god of the sea, symbolizing the ruler of the ocean. Surrounding him are statues of goddesses symbolizing abundance and health, with small statues representing the four seasons at the bottom. Water flows from around the statues into a shell-shaped pool, creating cascading streams. The overall design is magnificent and grand, attracting many tourists to visit.

La Fontana di Trevi, situata a Roma, Italia, è una fontana in stile barocco costruita sulla facciata di Palazzo Poli. Al centro si trova una statua di Nettuno, il dio del mare, che simboleggia il sovrano dell'oceano. Intorno a lui ci sono statue di dee che simboleggiano l'abbondanza e la salute, con piccole statue che rappresentano le quattro stagioni alla base. L'acqua scorre intorno alle statue in una vasca a forma di conchiglia, creando flussi a cascata. Il design complessivo è magnifico e grandioso, attirando molti turisti a visitarla.



## Iconography

Trevi Fountain in Rome is set against Palazzo Poli, with a grand façade featuring Corinthian pilasters linking two storeys. The theme, taming of water, is depicted through Tritons guiding Oceanus's chariot and taming hippocamps. A triumphal arch frames Oceanus, surrounded by free-standing columns. Flanking niches show Abundance spilling water and Salubrity with a snake-drinking cup. Bas-reliefs above illustrate the Roman aqueducts' origins.

La Fontana di Trevi a Roma è situata di fronte a Palazzo Poli, con una grandiosa facciata caratterizzata da pilastri corinzi che collegano due piani. Il tema del dominio delle acque è rappresentato dai Tritoni che guidano il carro di Oceano e domano gli ippocampi. Un arco trionfale incornicia Oceano, circondato da colonne indipendenti. Le nicchie laterali mostrano l'Abbondanza che versa acqua e la Salubrità con una coppa da cui beve un serpente. I bassorilievi sopra illustrano le origini degli acquedotti romani.



## Design and construction

The Trevi Fountain was originally redesigned in 1629 by Pope Urban VIII, who commissioned Gian Lorenzo Bernini, though the project was abandoned after his death. In 1730, Pope Clement XII organized a competition, and Nicola Salvi was awarded the commission in 1732. Salvi integrated the fountain into the Palazzo Poli and, after his death in 1751, four sculptors completed the work. Architect Giuseppe Pannini finalized the design in 1762, replacing earlier planned sculptures with allegorical figures. Made of travertine stone from Tivoli, the fountain was inaugurated by Pope Clement XIII and named for the intersection of three streets.

La Fontana di Trevi fu inizialmente ridisegnata nel 1629 da Papa Urbano VIII, che commissionò il progetto a Gian Lorenzo Bernini, ma il progetto fu abbandonato dopo la sua morte. Nel 1730, Papa Clemente XII organizzò un concorso e nel 1732 Nicola Salvi ottenne l'incarico. Salvi integrò la fontana nel Palazzo Poli e, dopo la sua morte nel 1751, quattro scultori completarono l'opera. L'architetto Giuseppe Pannini finalizò il design nel 1762, sostituendo le sculture pianificate con figure allegoriche. Realizzata in travertino di Tivoli, la fontana fu inaugurata da Papa Clemente XIII e prende il nome dall'incrocio di tre strade.

# Force Balance

受力平衡

Physical operations

物理运算

$$F = G \frac{m_1 m_2}{d^2}$$

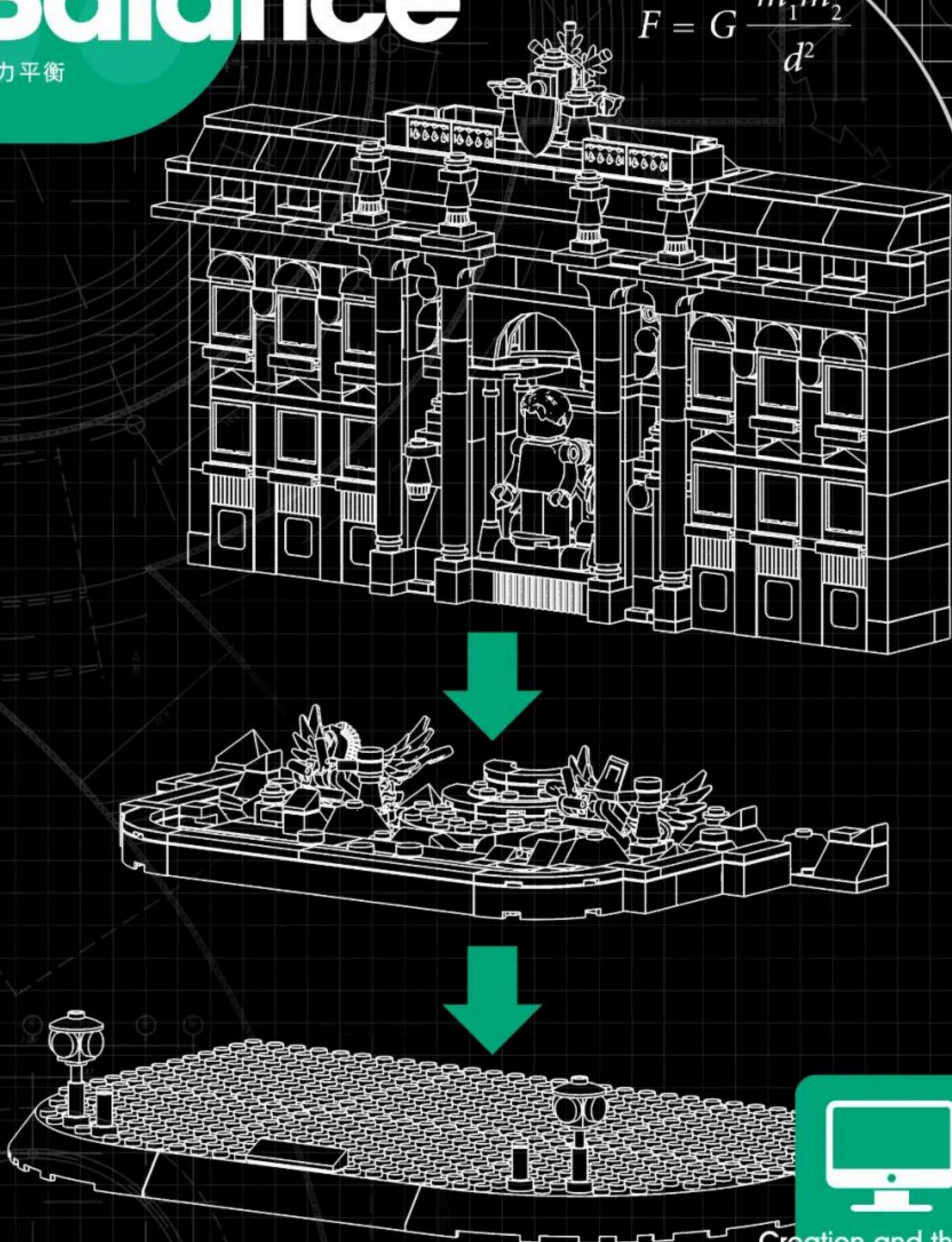

Creation and thinking

创作·思考

# Special parts

特殊零件的开发利用

$$S=4\pi \cdot r^2$$

$$a^2+b^2=c^2$$

**WG1223**

矮柱球带柄

**WG1540**

高长14孔

**WG1527**

灯笼穗1孔

**WG1368**

公仔手臂

**WG1251**

方正凹1孔

**WG1345**

竖纹2倍2孔

**WG1360**

波纹4孔

**WG1273**

4倍半斜

$$\sin^2 a + \cos^2 a = 1$$

**WG1410**

4倍高1孔



features and functions

特点.功能

# Main Color Matching

配色方案



Pantone Black 6C



Pantone 431C



Pantone 2312C



Pantone Cool Gray 6C



Pantone 2184C



Pantone 143C

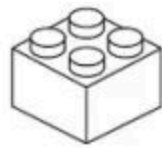

White



## Color matching

Adopting 3 main colors, White, black and light gray as the main color, the more reasonable and bold color matching on the original building, making the product more atmospheric and the whole design is more reasonable.

# Trevi Fountain

意大利罗马许愿池



Front

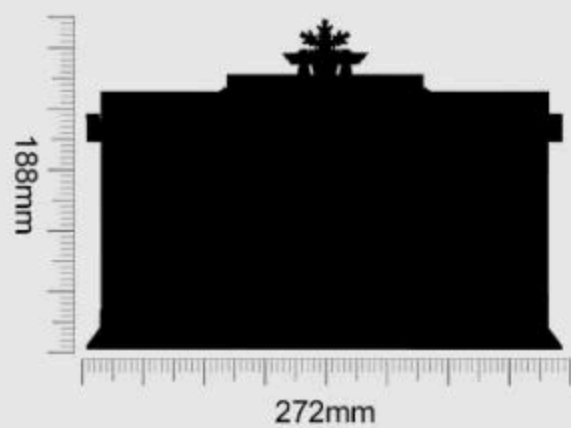

Left

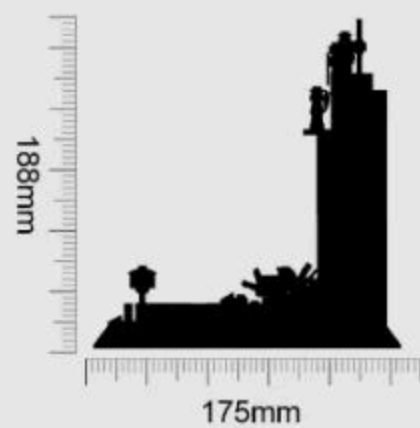

Back

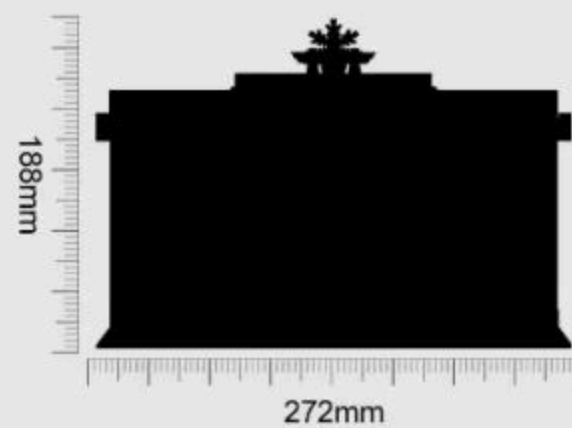

Product Size:272X175X188mm



小提示：积木包分为底板包、整版配件包及普通配件包,底板包标识为A/B/C...,普通配件包编码与说明书对应,整版配件包无标识。  
 Tip: Building block packs are divided into baseplate packs, runner accessory packs, and standard accessory packs. Baseplate packs are labeled A/B/C..., regular accessory packs have codes that correspond to the instructions, and runner accessory packs have no labels.



■ Open the product packaging correctly and classify the building block packs by type.

用正确方式拆解产品外包装,按积木包类型进行分类。



■ Confirm the quantity of building block packs and cross-check them with the pack identifiers and the instructions.

确认积木包数量,对照积木包标识和说明书步骤。



■ Open the building block packs according to the pack identifier steps. Sort them in order by type and color for easier assembly.

按积木包标识步骤拆开积木包,按顺序以类型、颜色进行分类以便搭建。



■ Assemble your building block model following the steps in the instruction manual.

按说明书步骤拼装并完成你的积木模型。



# 1:1 Physical Reference Table

十字棒配件1:1尺寸参照表



Instructions For Use

让安装更简单

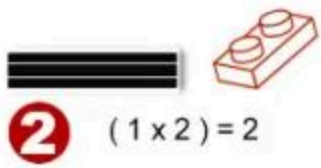

**2**  $(1 \times 2) = 2$

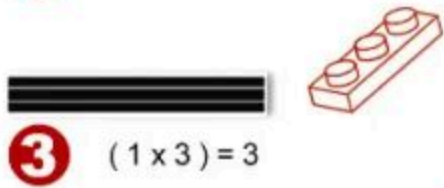

**3**  $(1 \times 3) = 3$

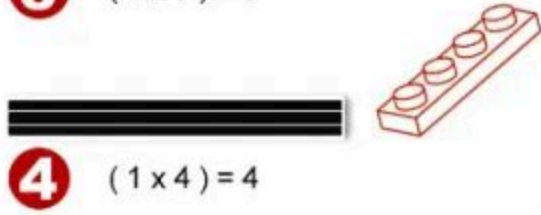

**4**  $(1 \times 4) = 4$

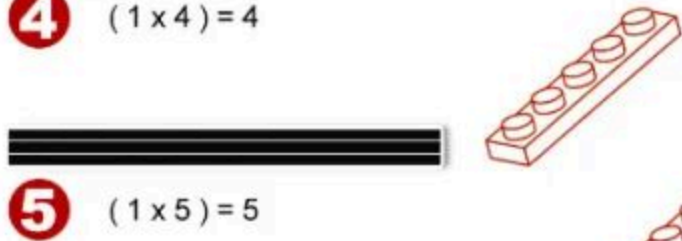

**5**  $(1 \times 5) = 5$



**6**  $(1 \times 6) = 6$



**7**  $(1 \times 7) = 7$



**8**  $(1 \times 8) = 8$



**9**  $(1 \times 9) = 9$



**10**  $(1 \times 10) = 10$



**12**  $(1 \times 12) = 12$



**16**  $(1 \times 16) = 16$



# PARTS LIST

配件清单



x2

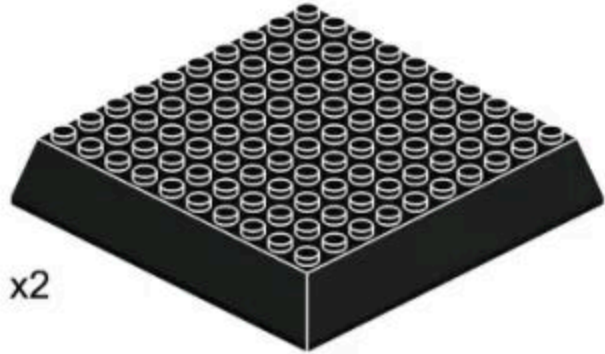

x2



x2



x1



x1



x2



x1



x2



x2



x2



x14



x2



x2

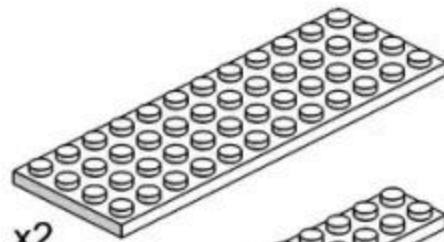

x2

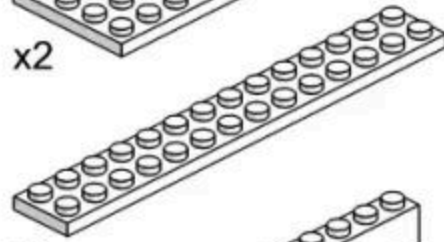

x1

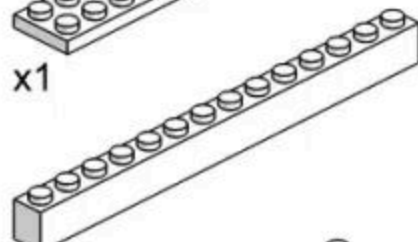

x5

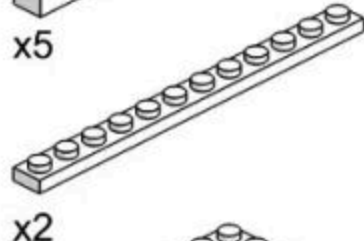

x2

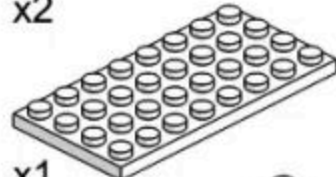

x1

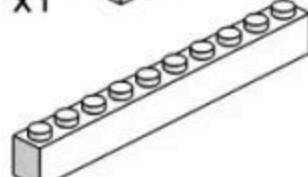

x3

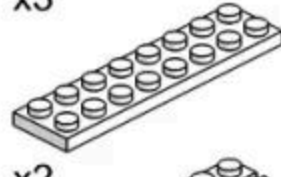

x2

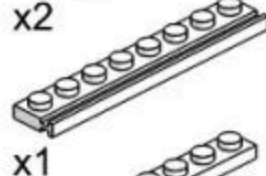

x1



x1



x1

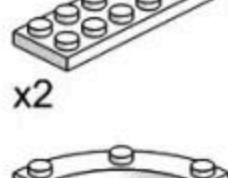

x2

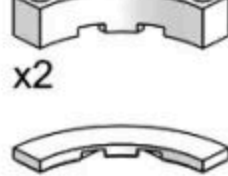

x2

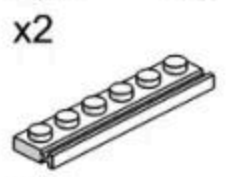

x1

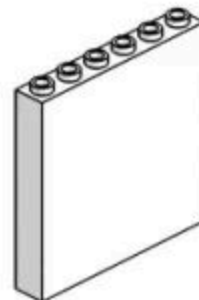

x10

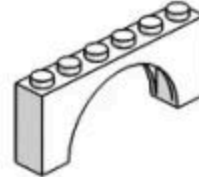

x1

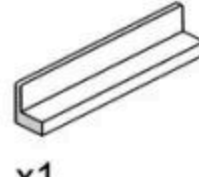

x1

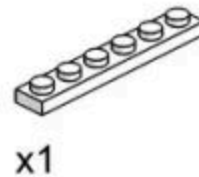

x1

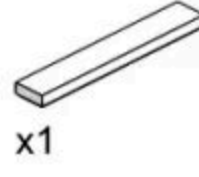

x1

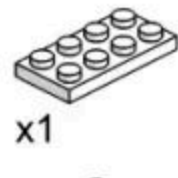

x1

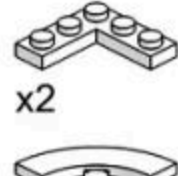

x2

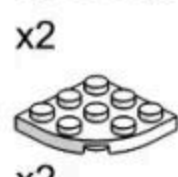

x2

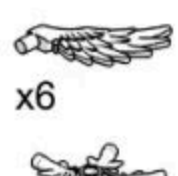

x6

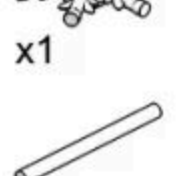

x1

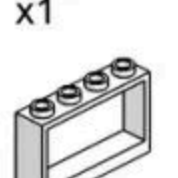

x10

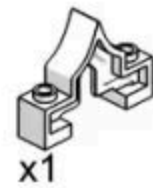

x1

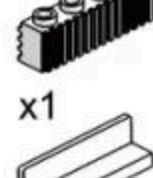
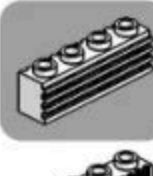

x1

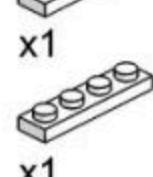

x1

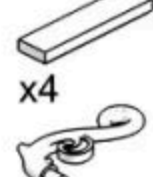

x4

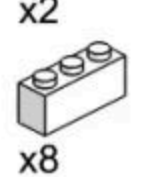

x2

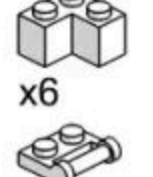

x8

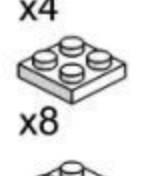

x6

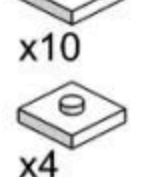

x4

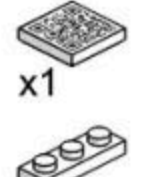

x10

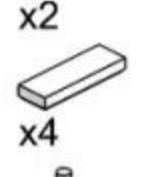

x4

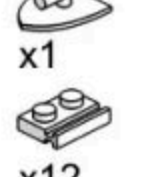

x2



x12



x1



x4



x6



x12

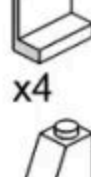

x4



x2



x1



x6

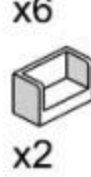

x6



x2



x4



x9



x6



x17

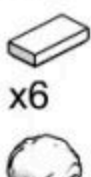

x6



x1



x2



x2



x7



x3



x6



x1



x1



x4



x1



x12



x1



x17



x8



x2



x4

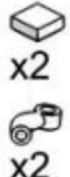

x2



x6



x28



x2



x2



x2



x2



x2



x5

产品有增补件请以实物为准

If product has additional parts, please in kind prevail.

# PARTS LIST

配件清单

	x2		x3		x2		x1		x2		x1
	x1		x1		x1		x1		x1		x1
	x1		x4		x1		x1		x2		x1
	x2		x1		x4		x1		x2		x1
	x2		x4		x4		x1		x1		x1
	x1		x2		x2		x1		x2		x3
	x1		x1		x6		x1		x2		x1
	x1		x1		x1		x2		x1		x1
	x4		x8		x2		x1		x3		x1
	x1		x4		x2		x1		x2		x1
	x1		x4		x4		x2		x3		x6
	x1		x4		x4		x2		x1		x2
	x2		x4		x2		x2		x12		x8
	x1		x3		x2		x4		x6		x3
	x2		x2		x2		x2		x2		
	x2		x2		x1		x2		x2		

产品有增补件请以实物为准

If product has additional parts, please in kind prevail.



232PCS

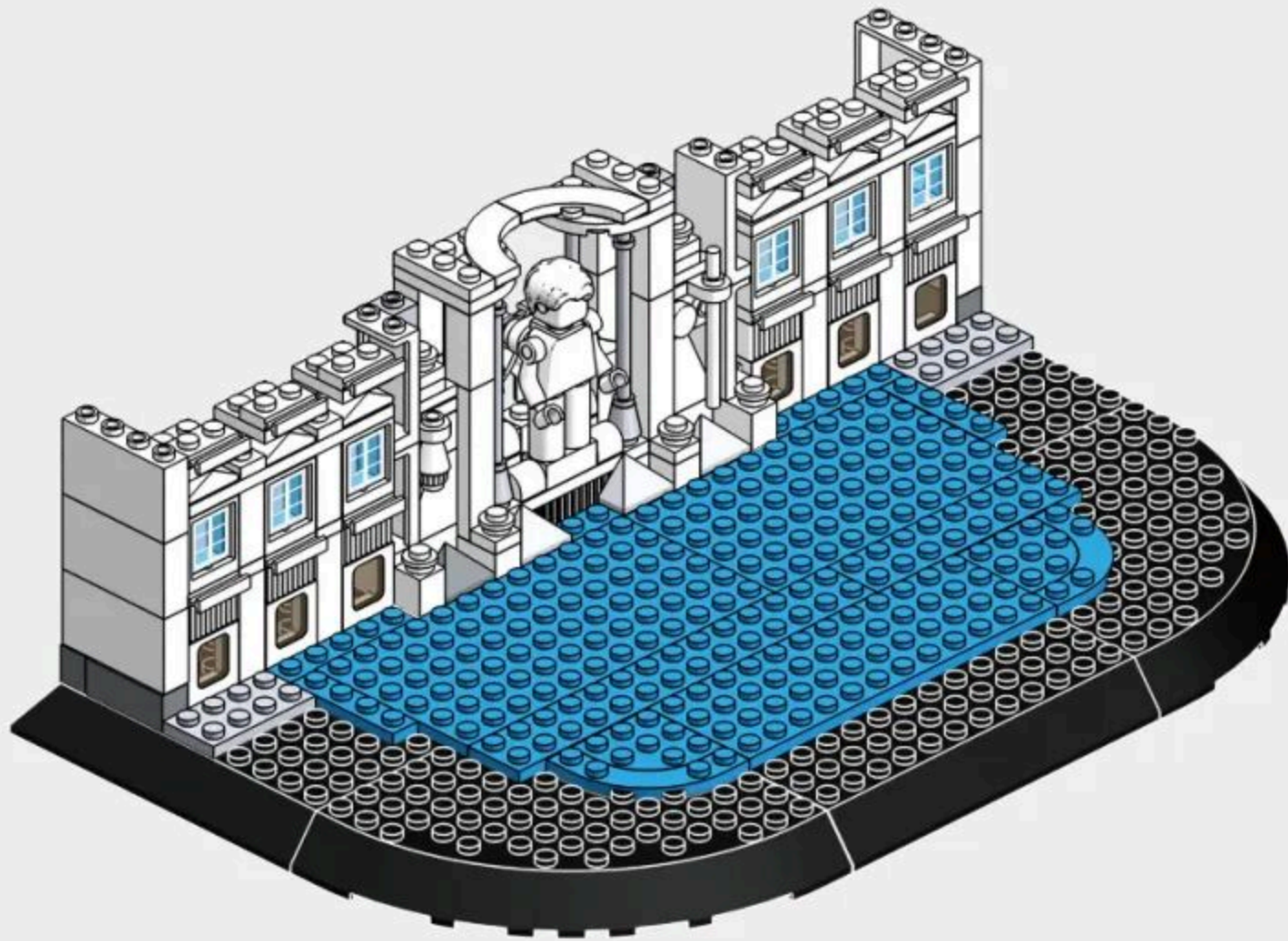

1-1

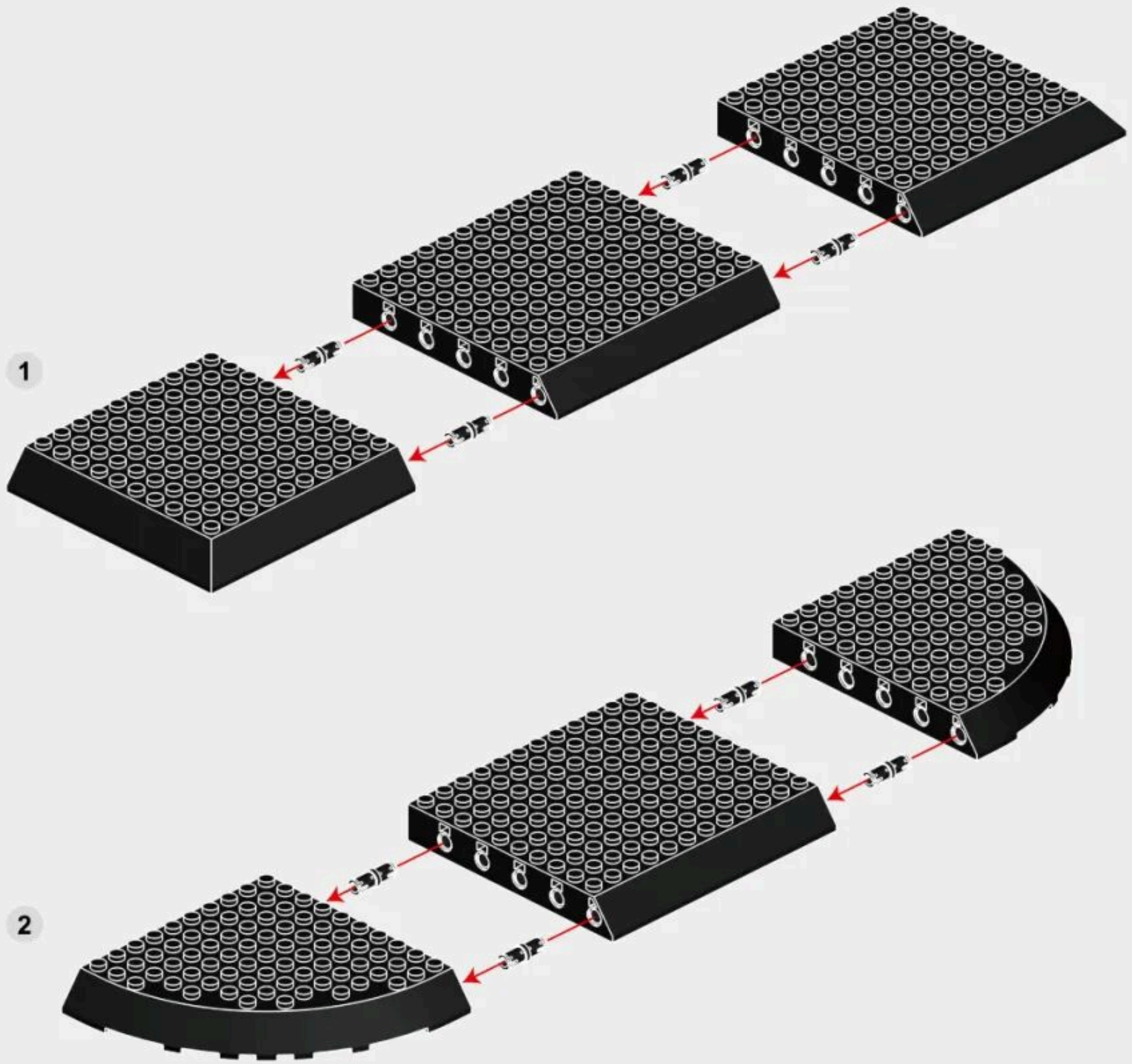
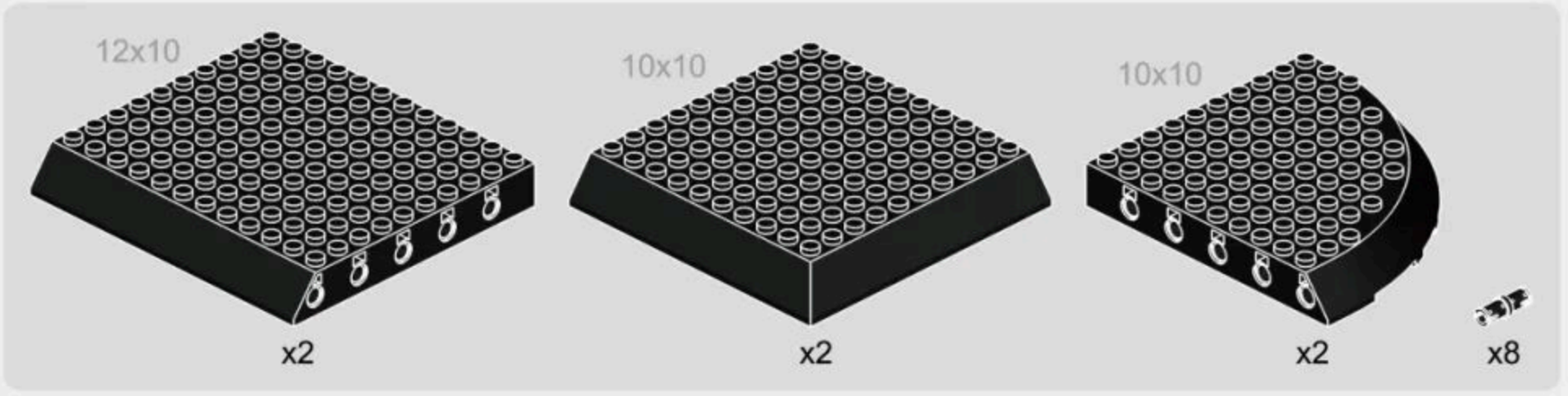

# 1-2

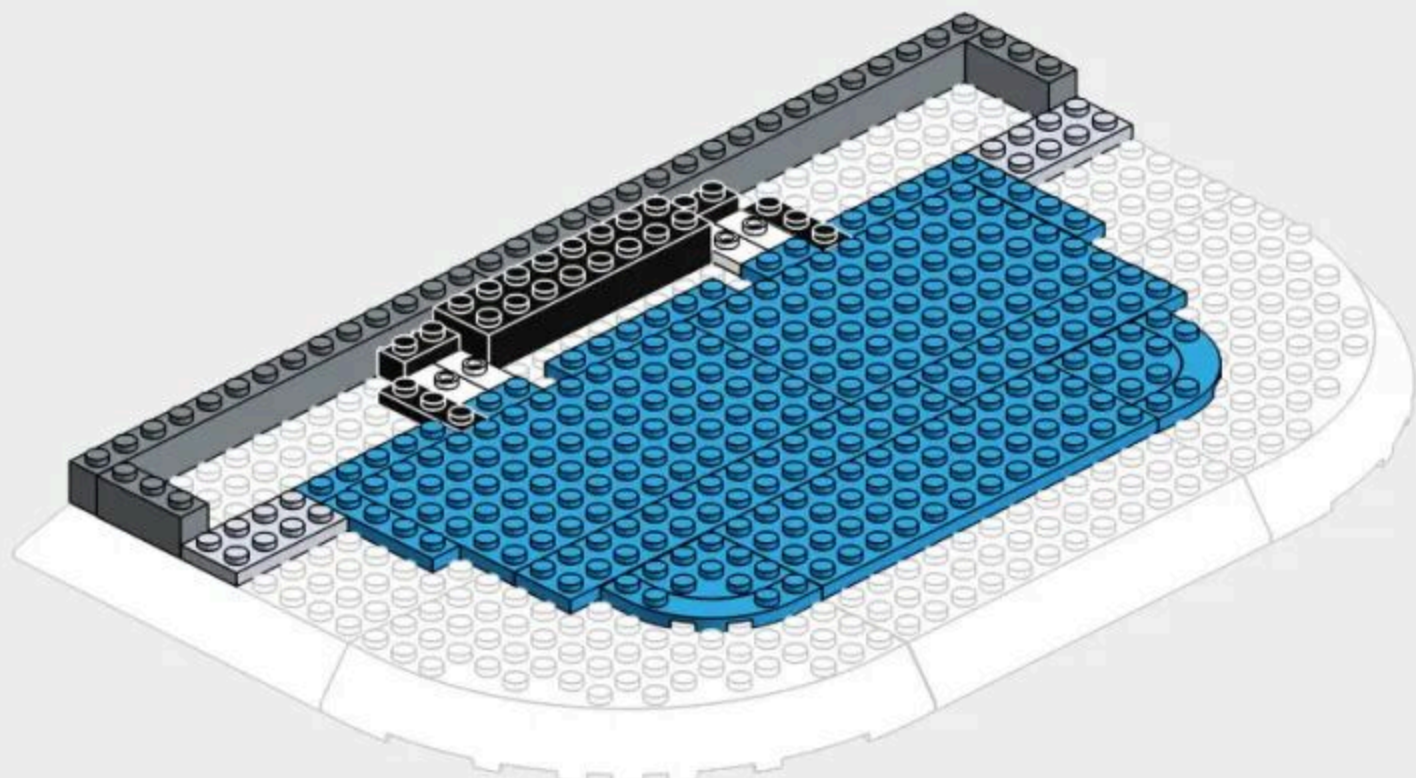
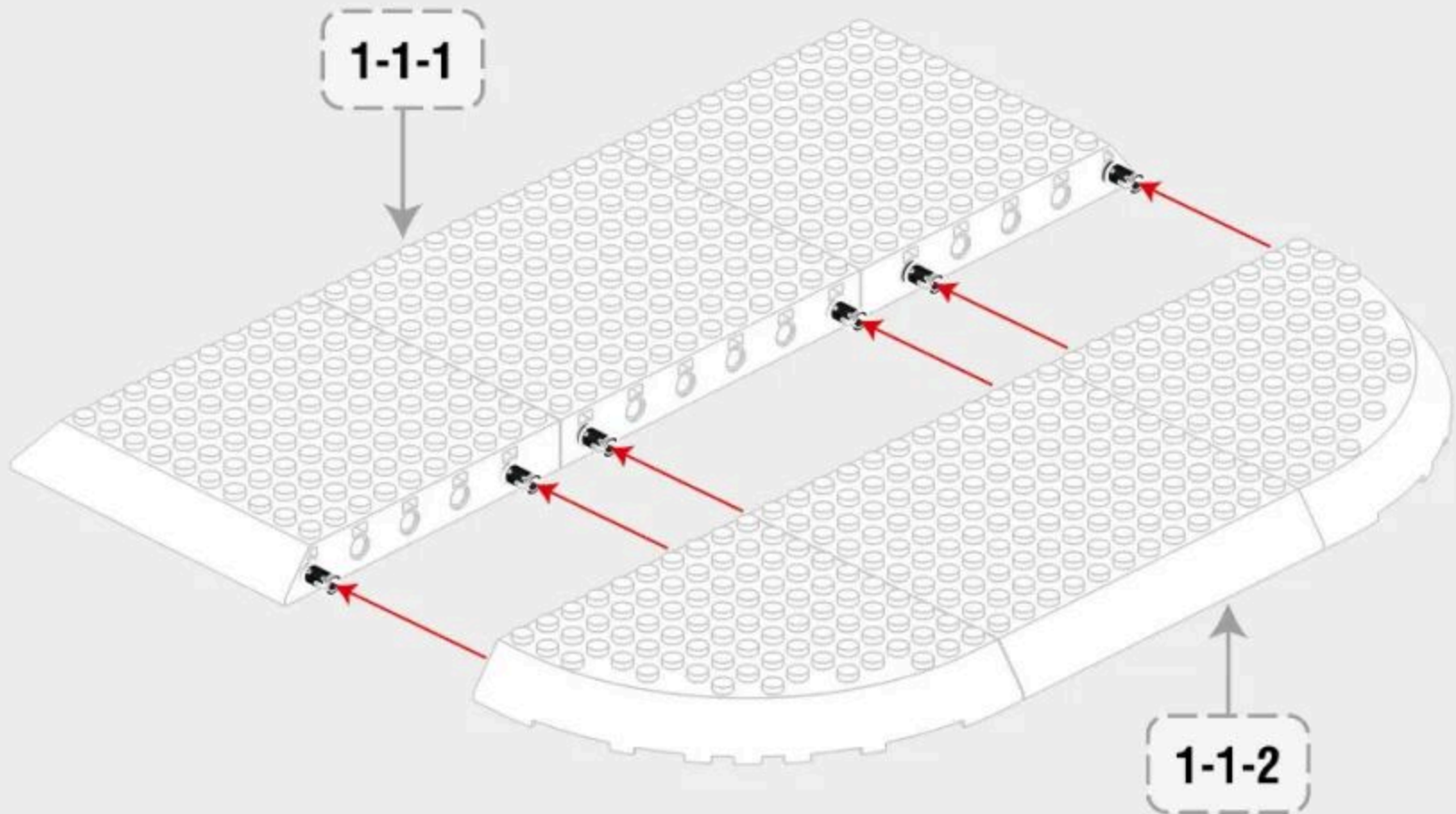
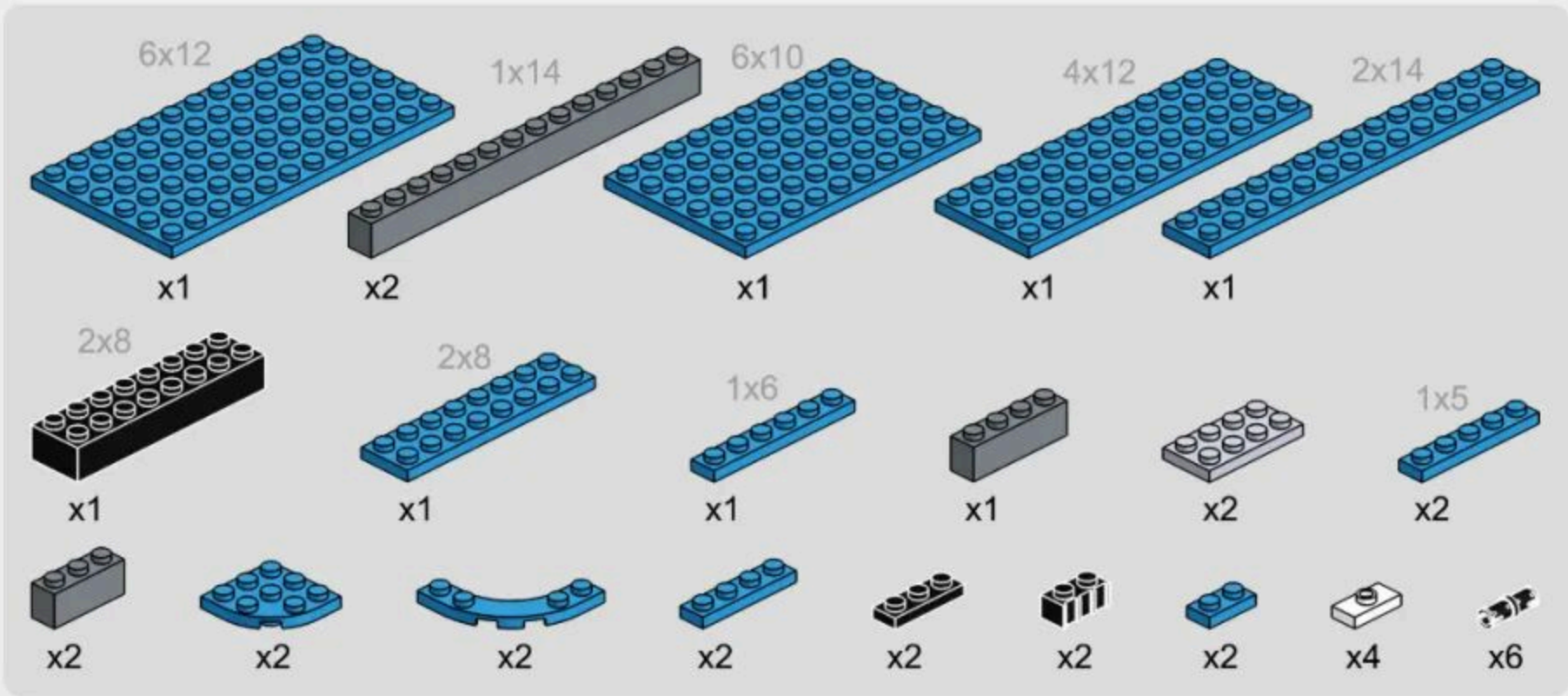

1-3

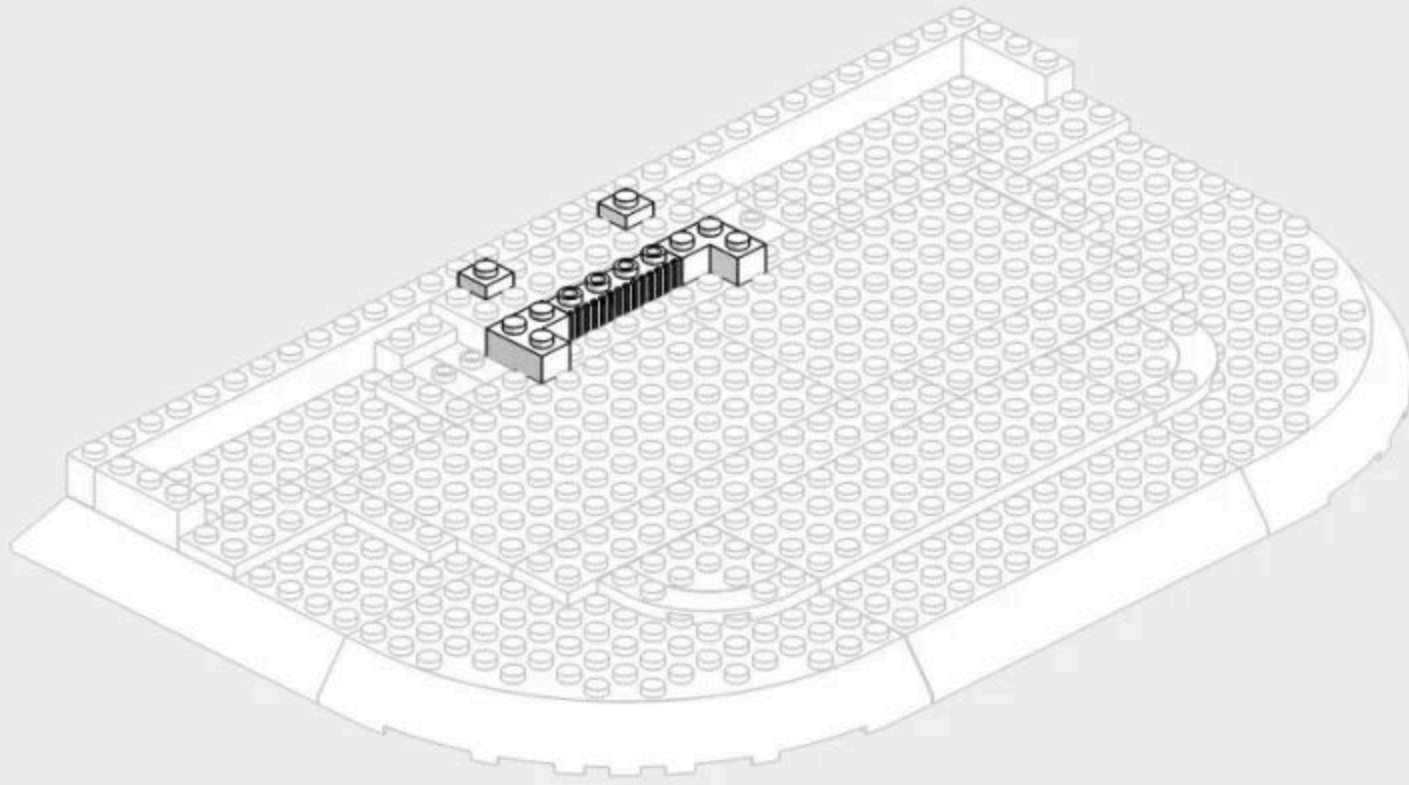

1-4

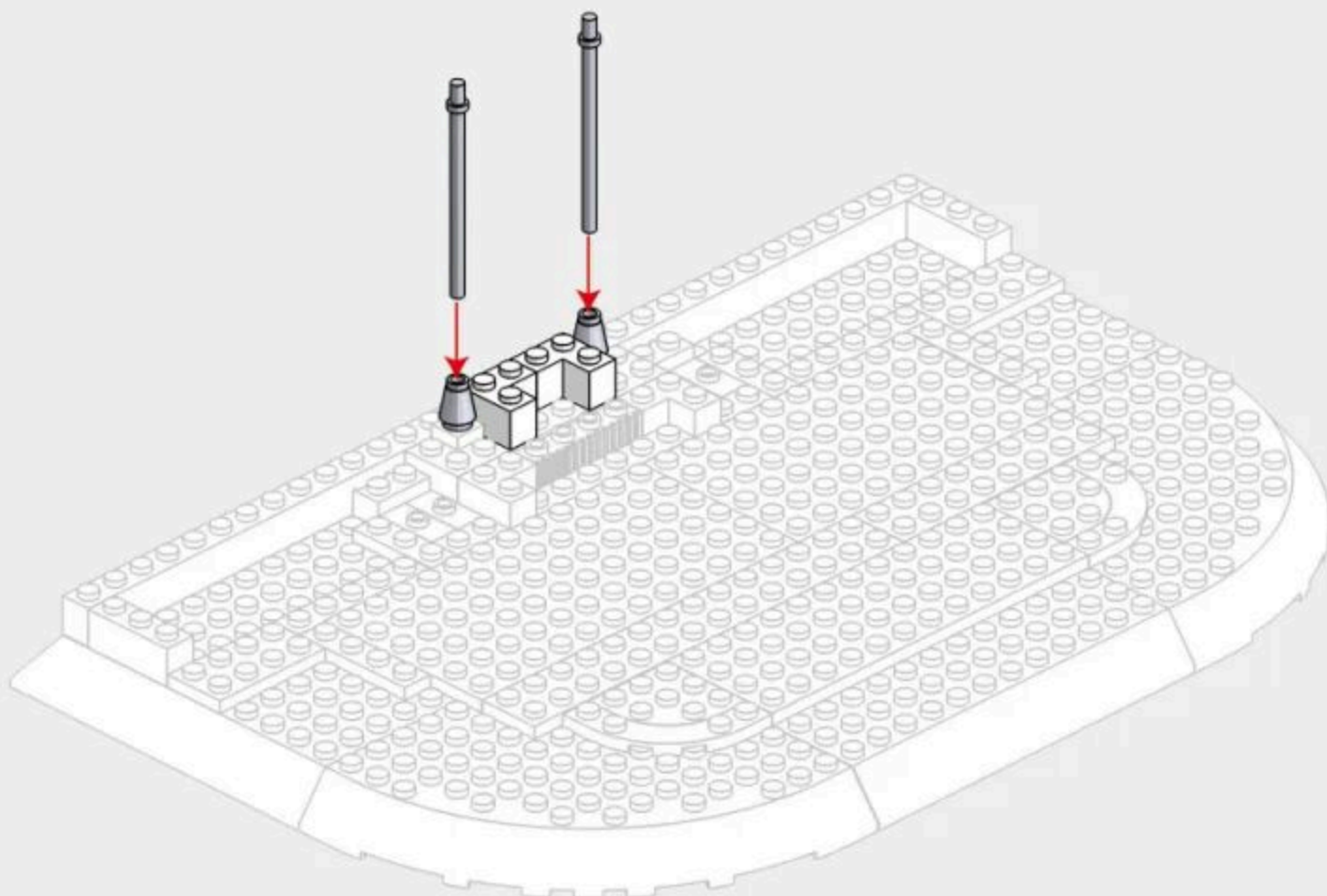
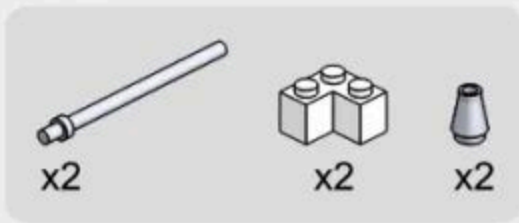

# 1-5

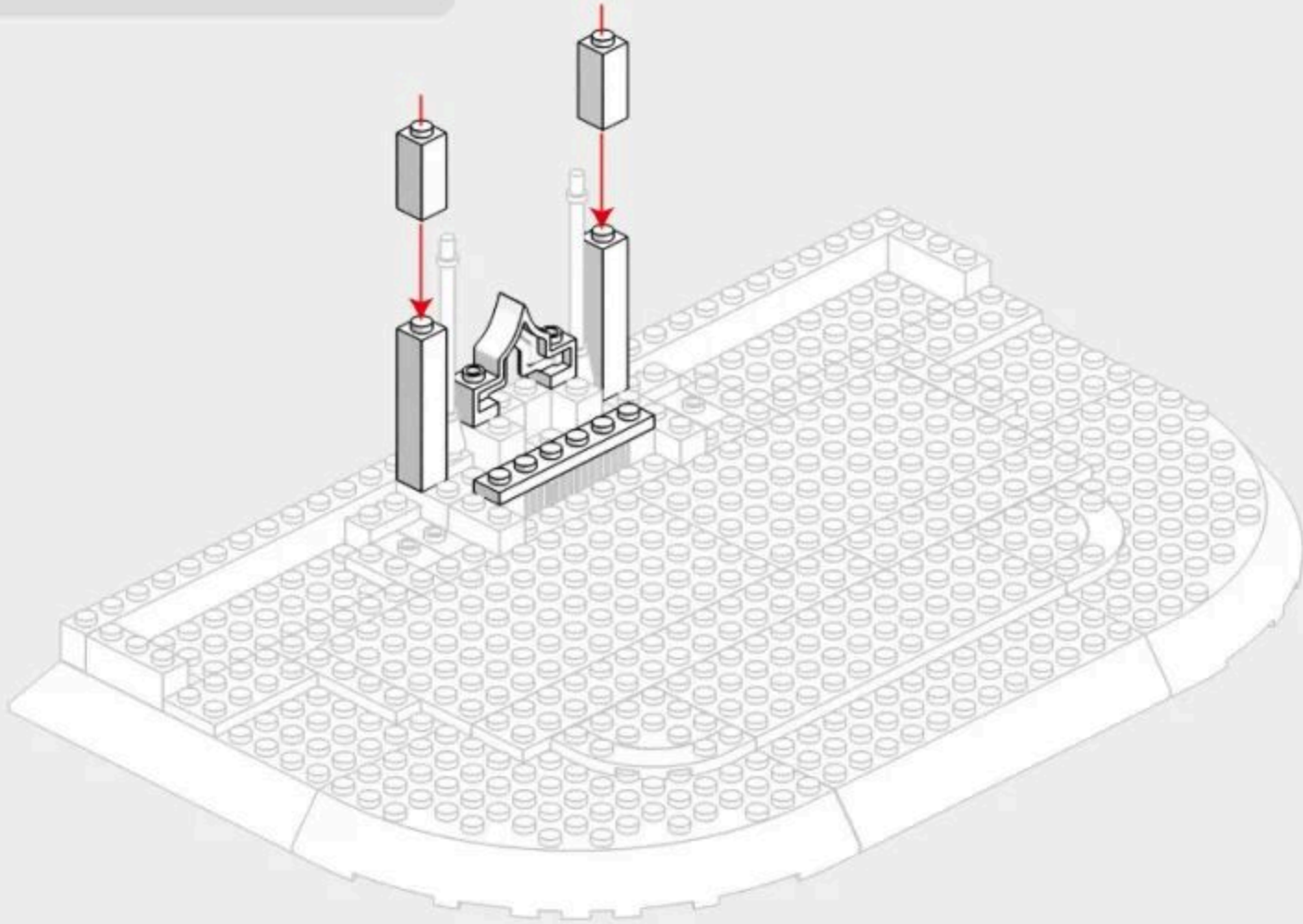
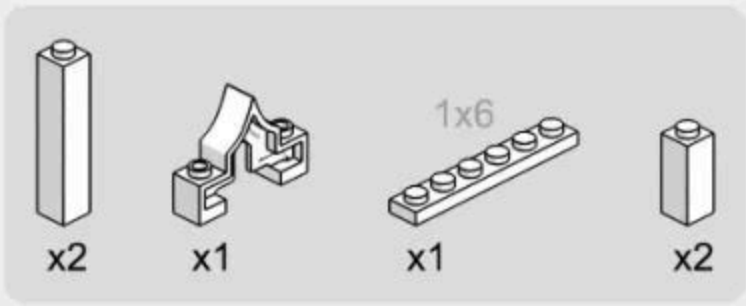

# 1-6

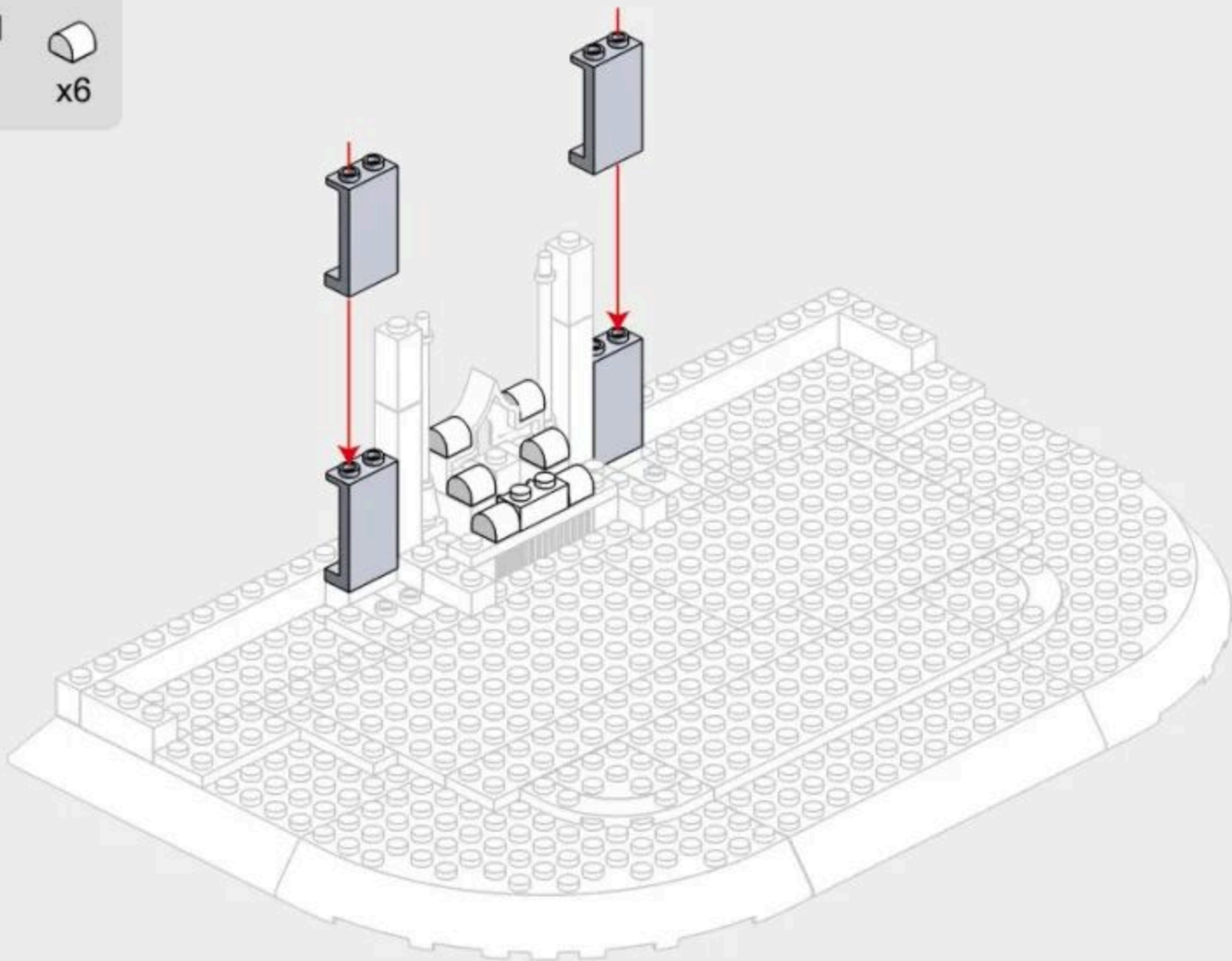
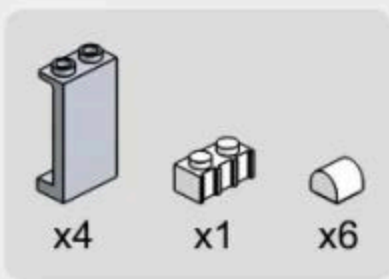

1-7

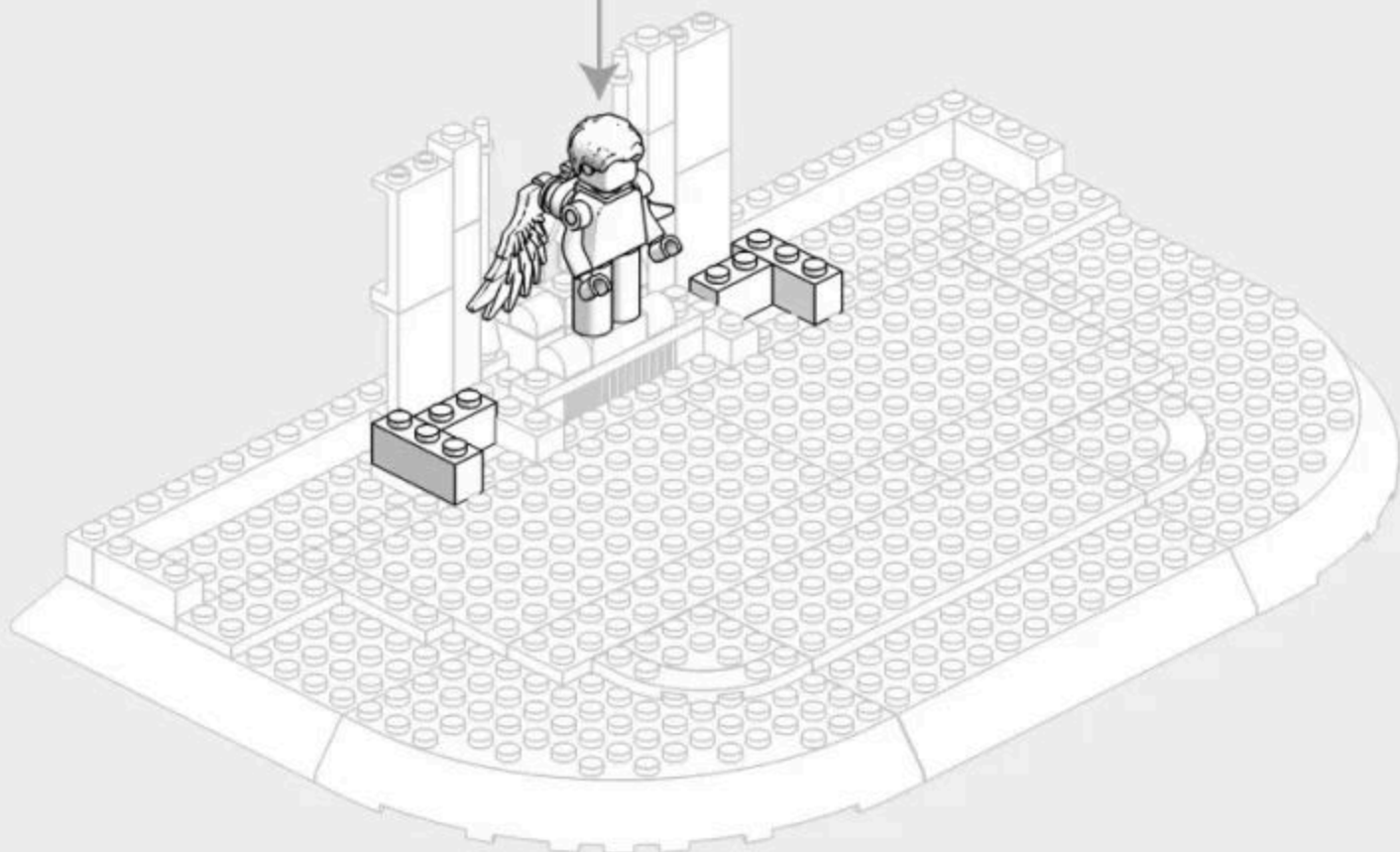
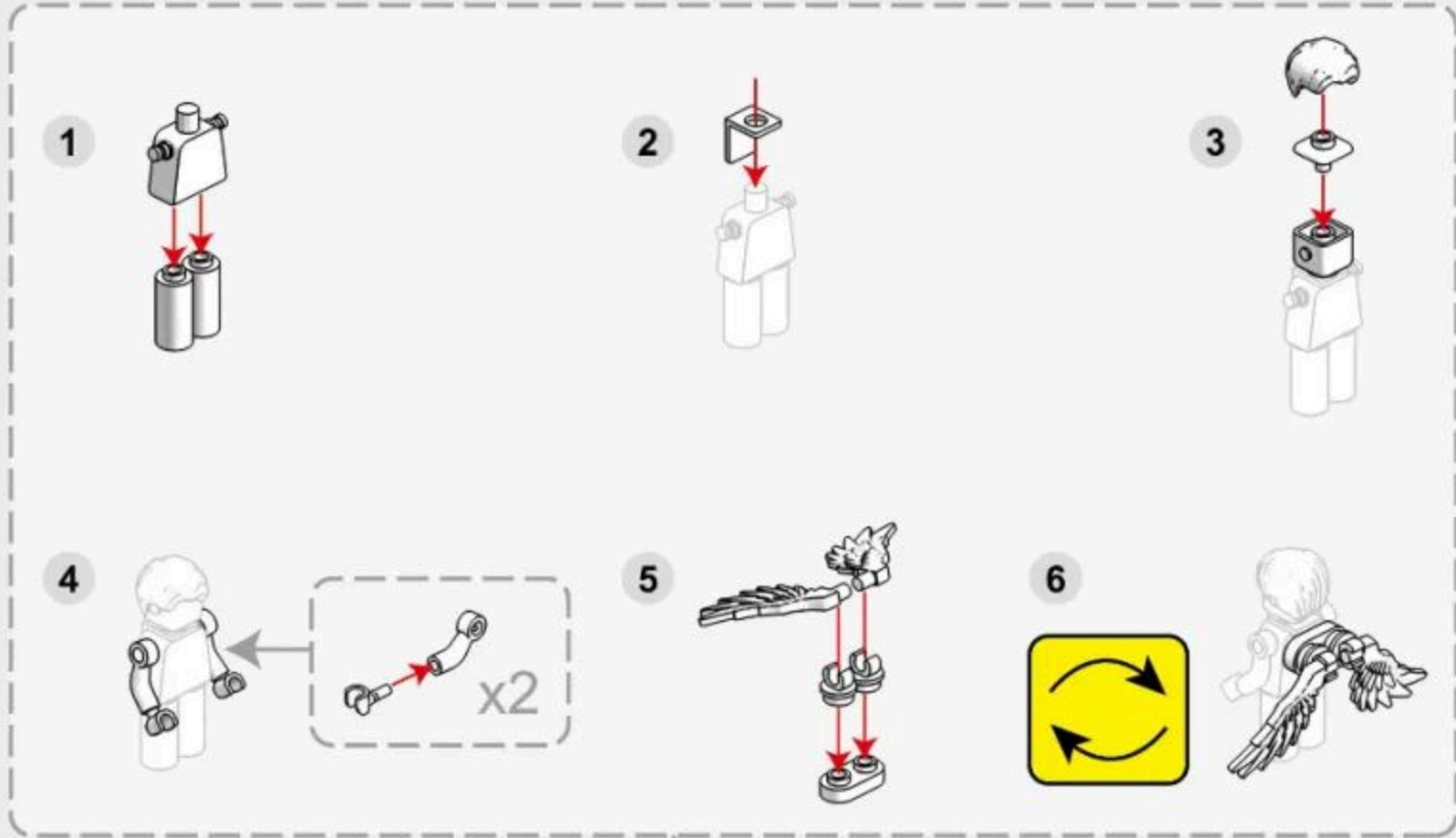
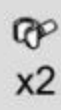

# 1-8

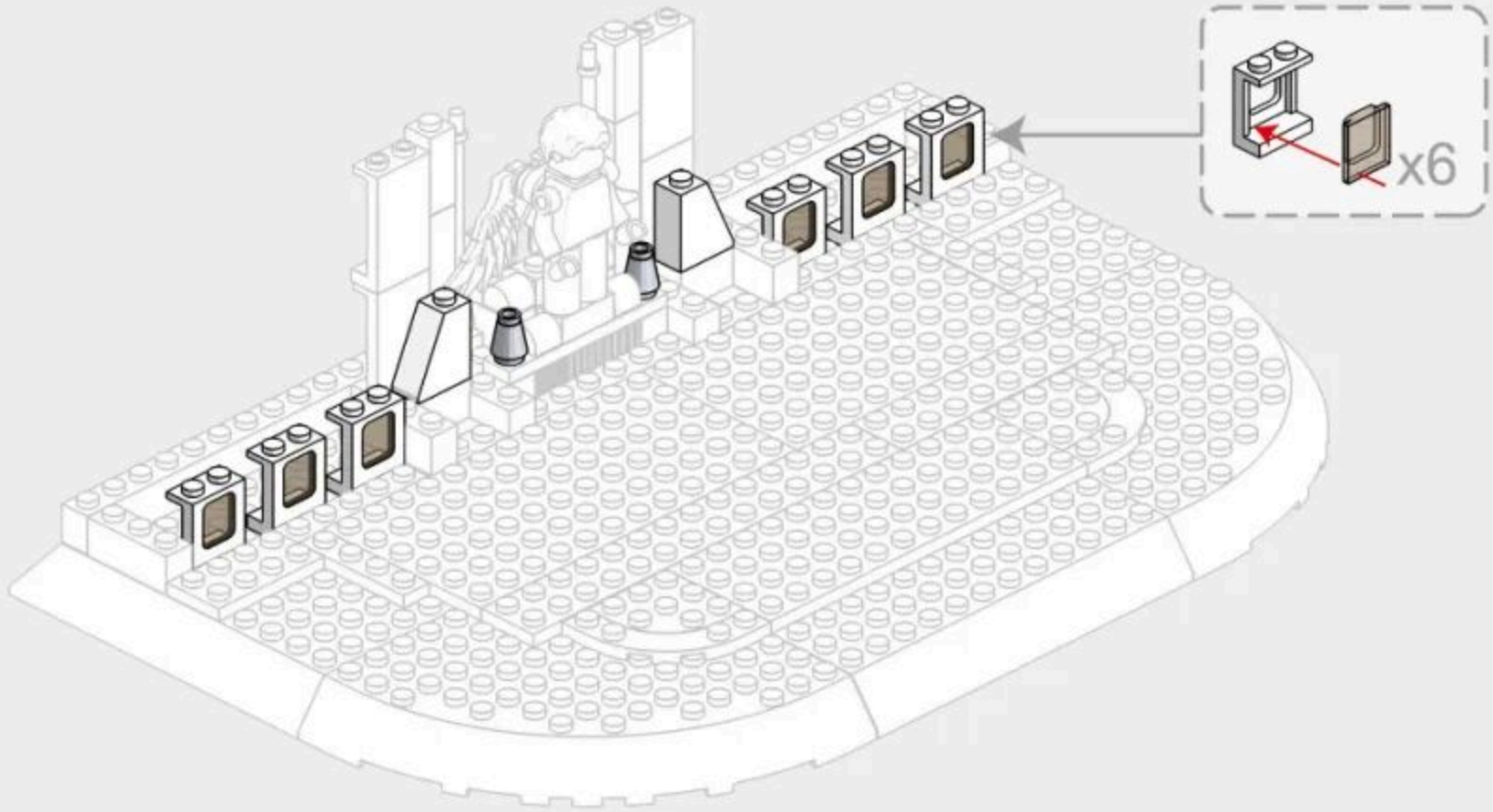

# 1-9

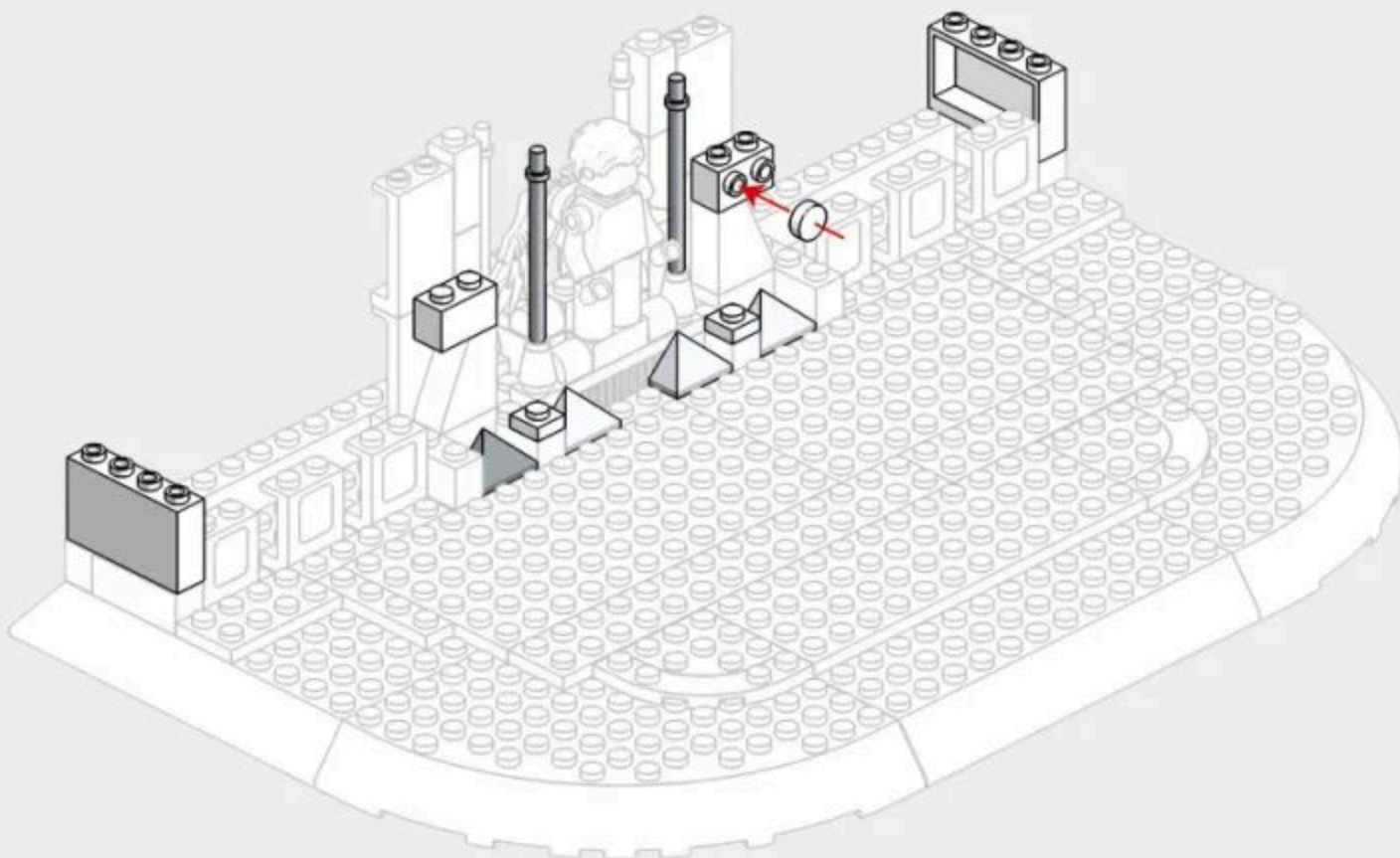
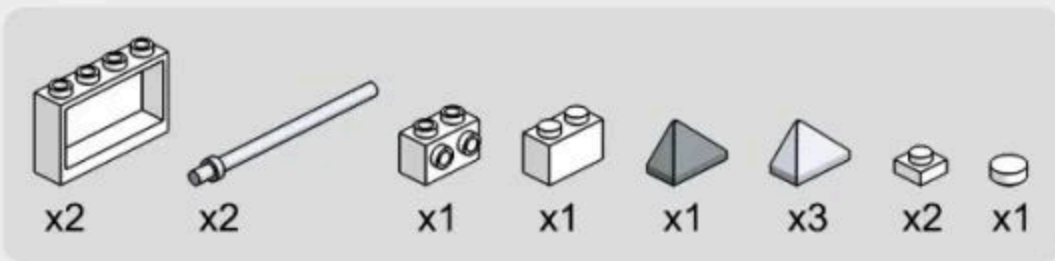

# 1-10

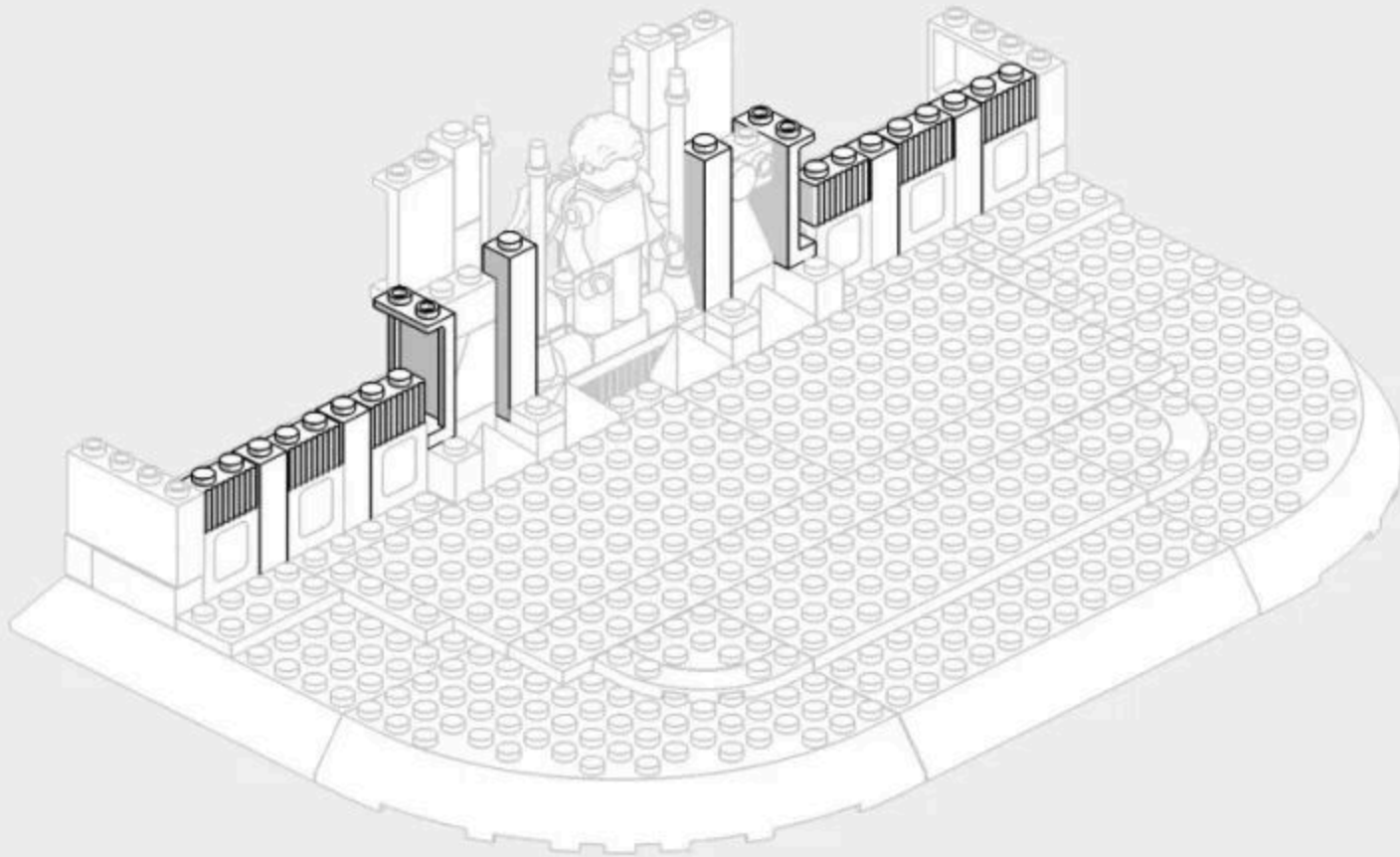
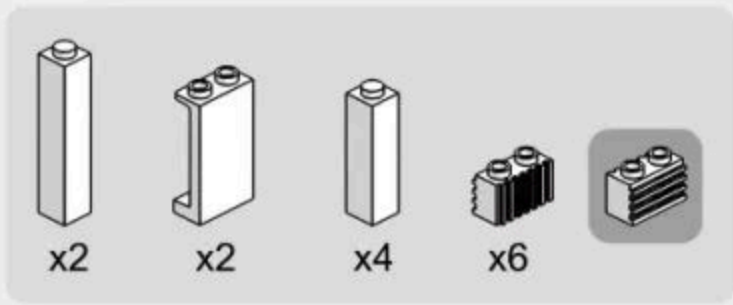

# 1-11

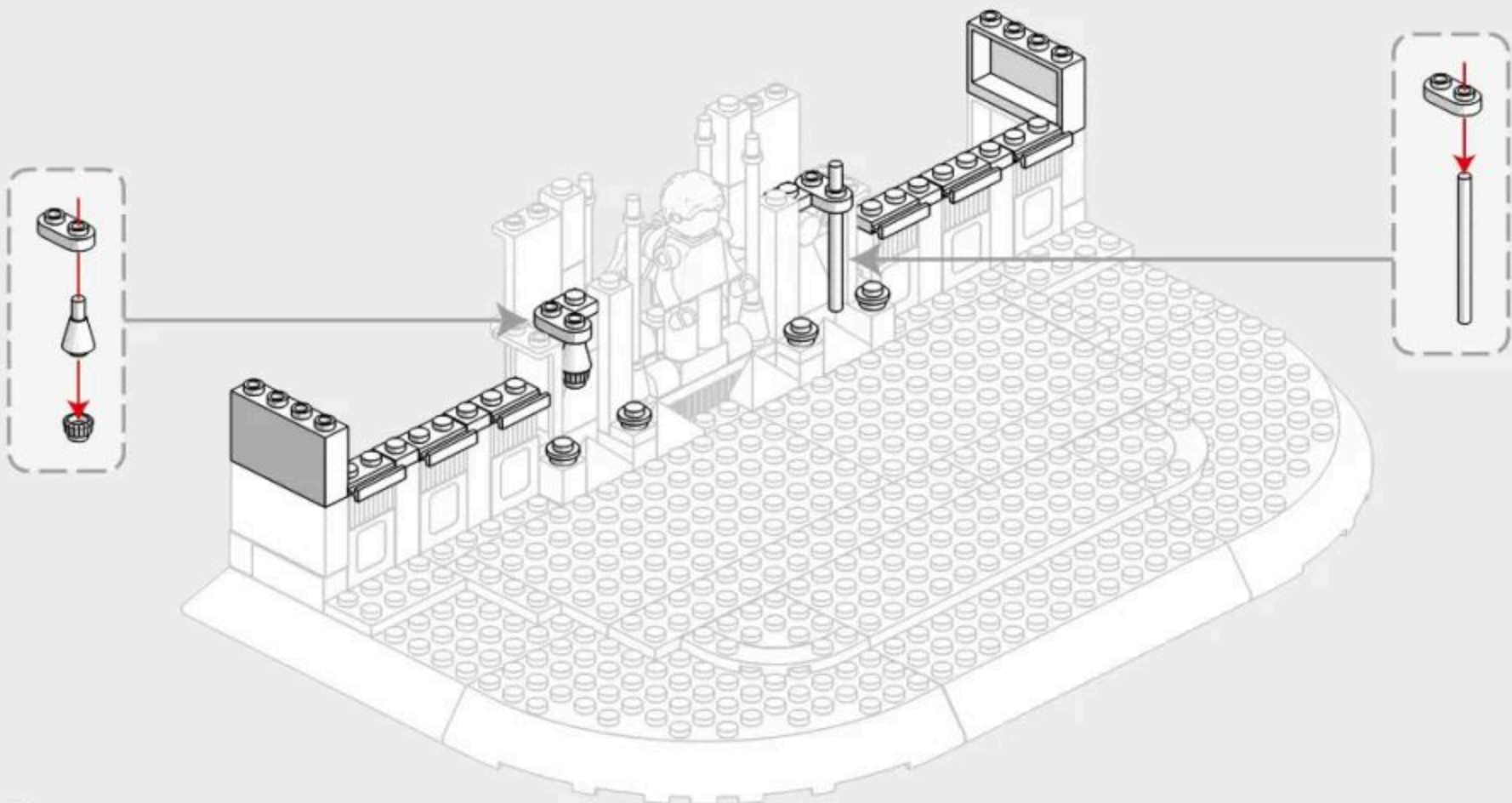

# 1-12

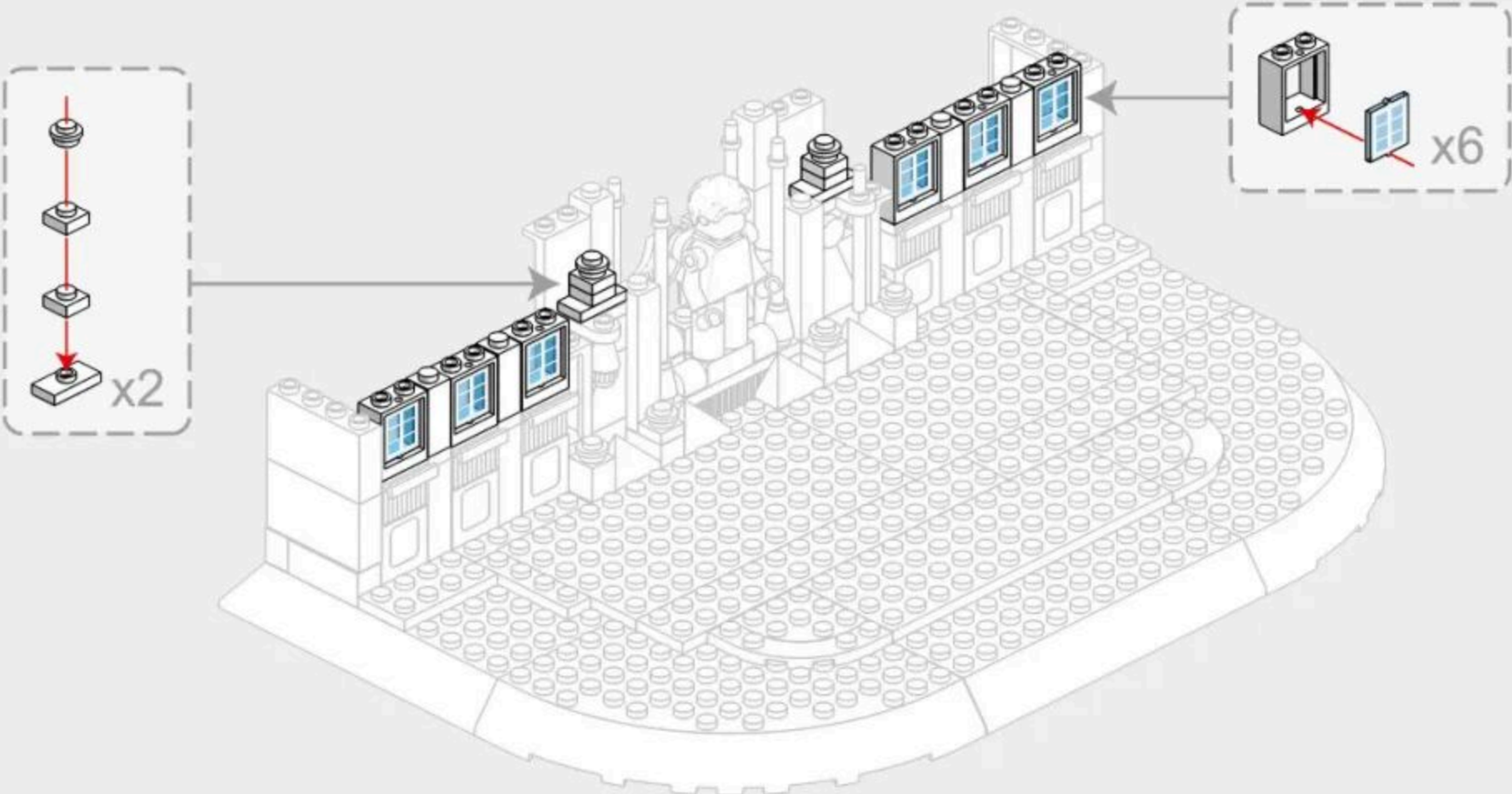
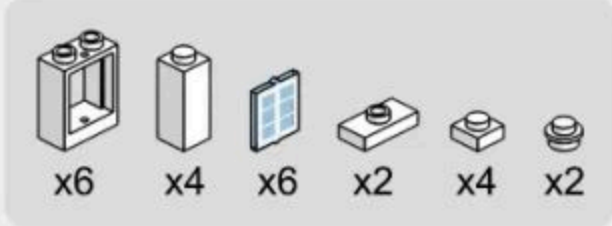

# 1-13

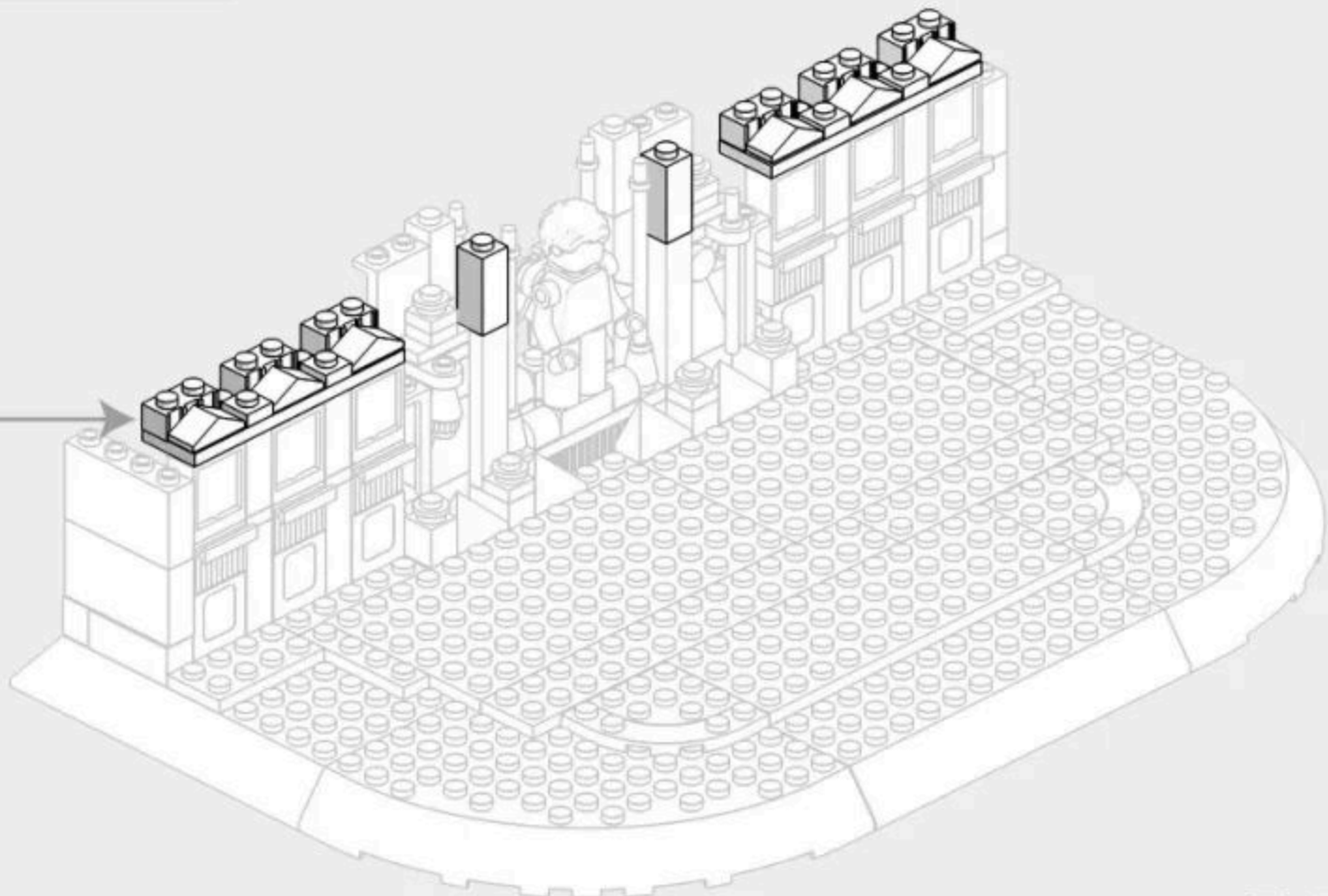
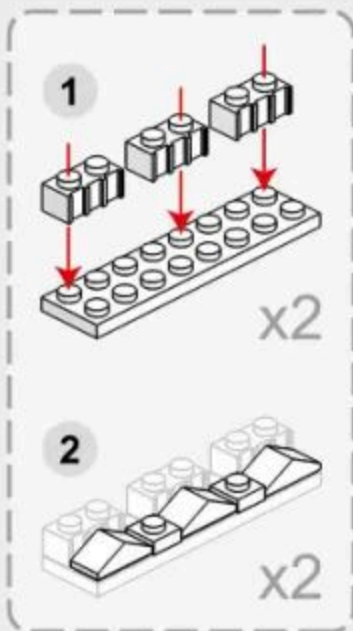
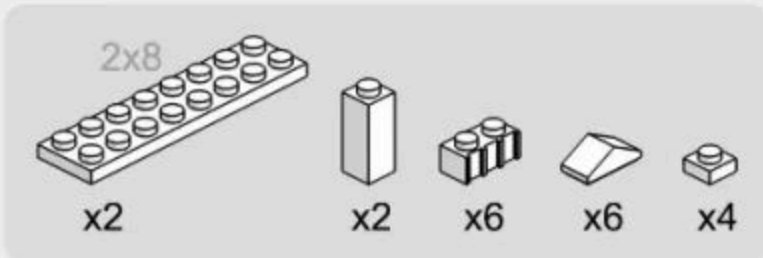

# 1-14

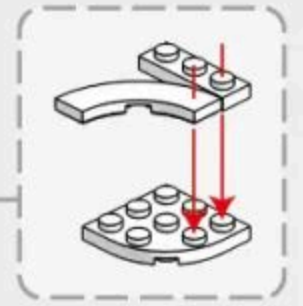
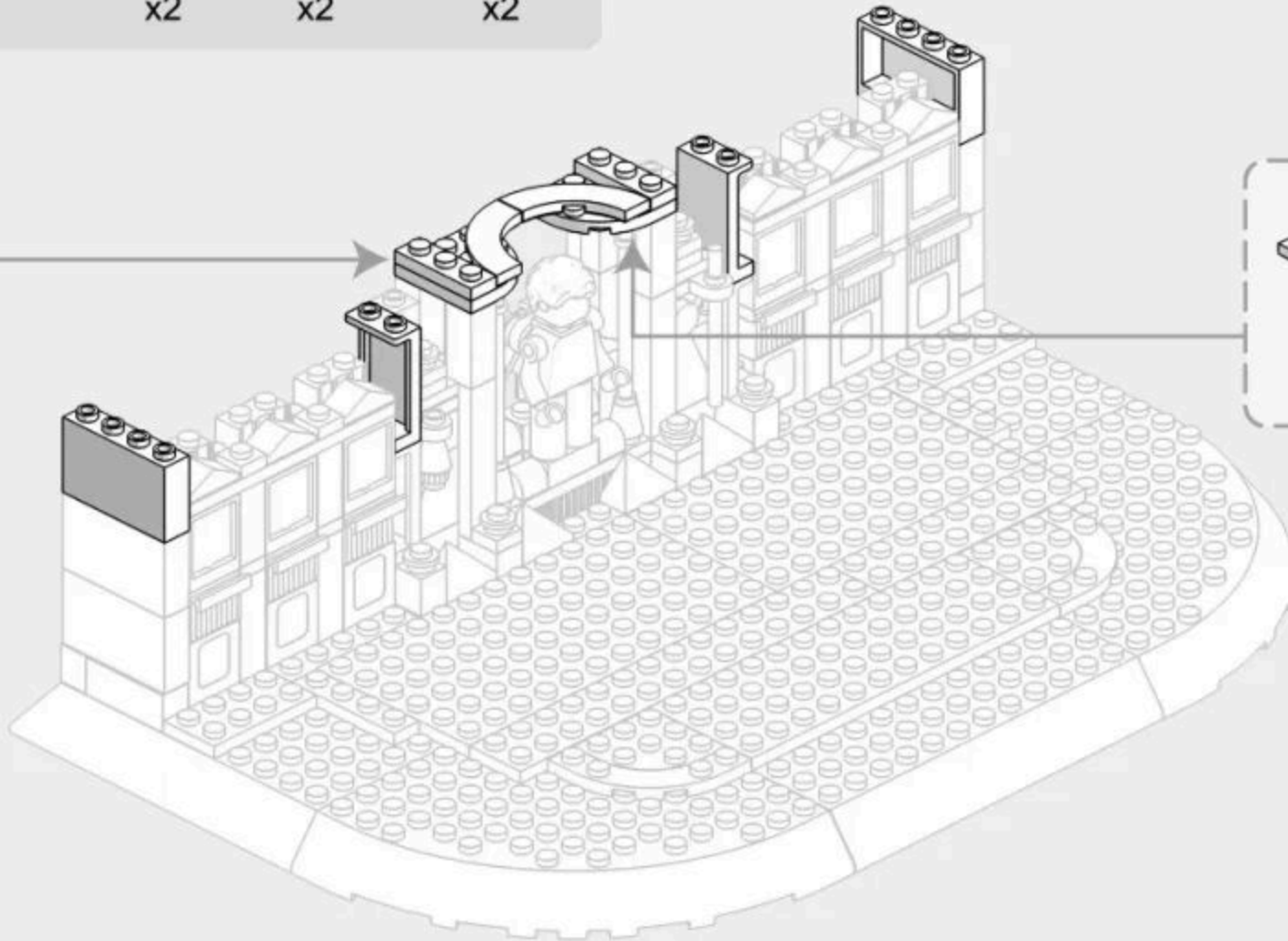
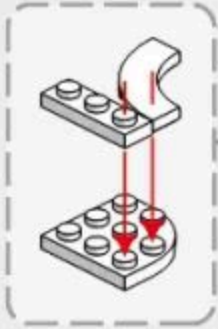
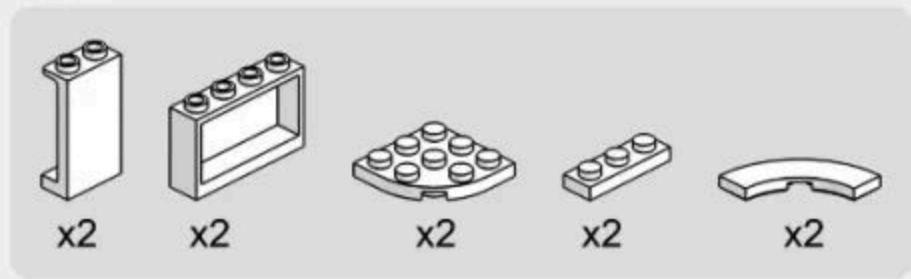

# 1-15

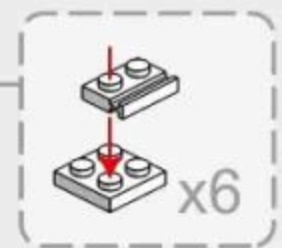
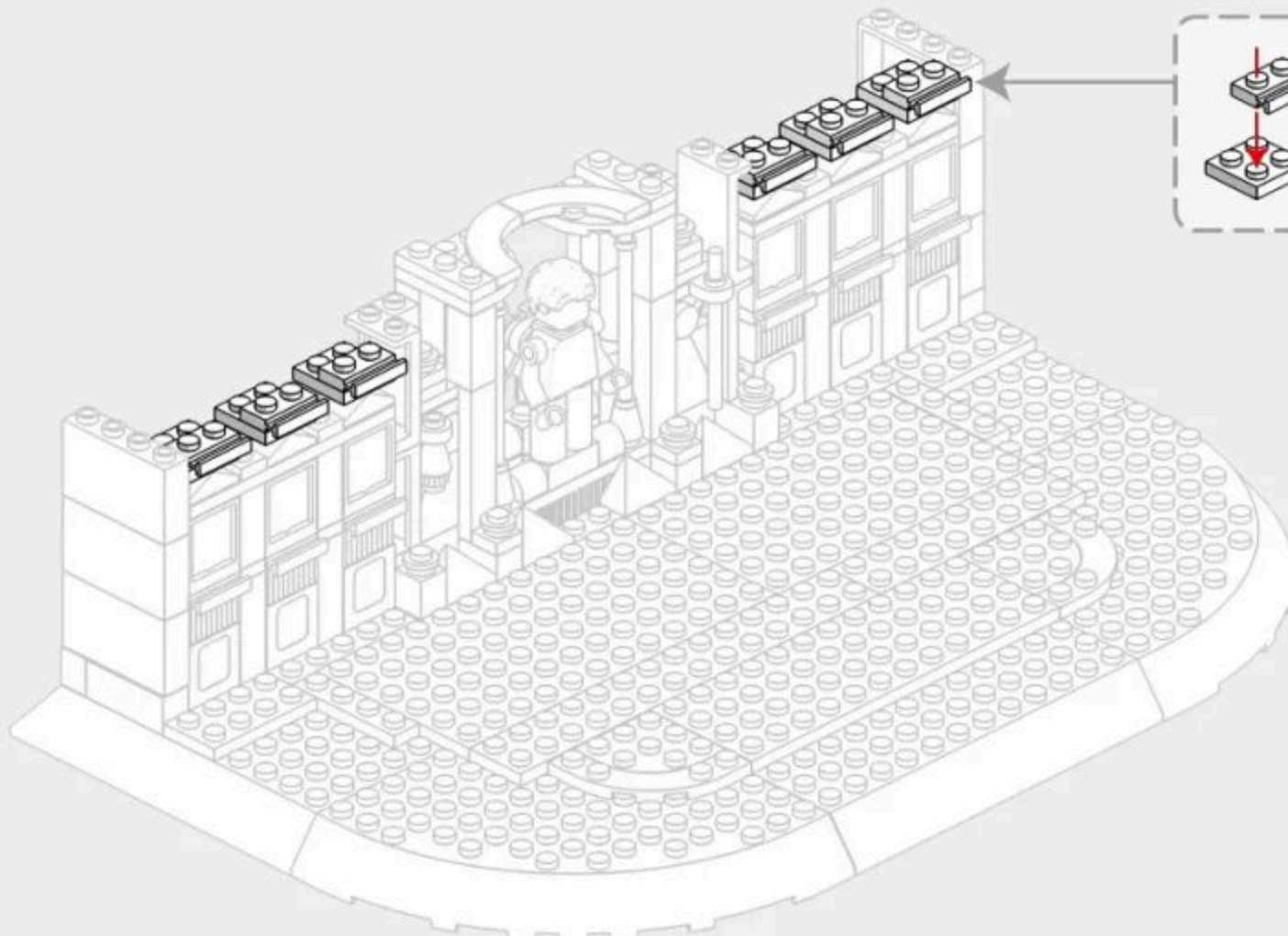





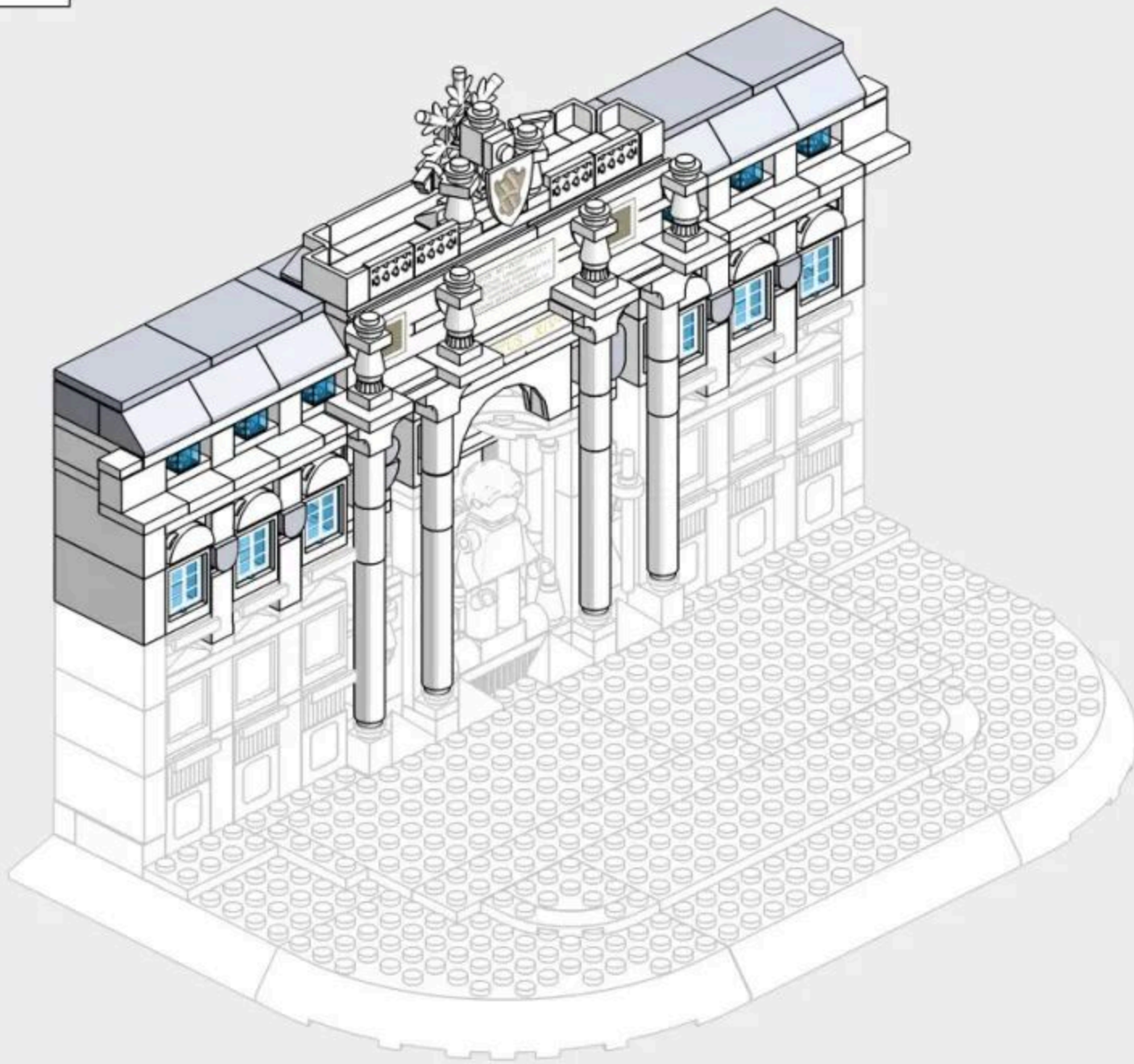





240PCS



# 2-1

-  x2
-  x2
-  x4
-  x2
-  x2
-  x2
-  x1
-  x4
-  x4

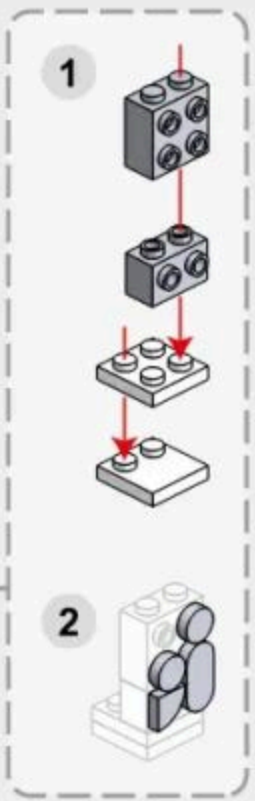
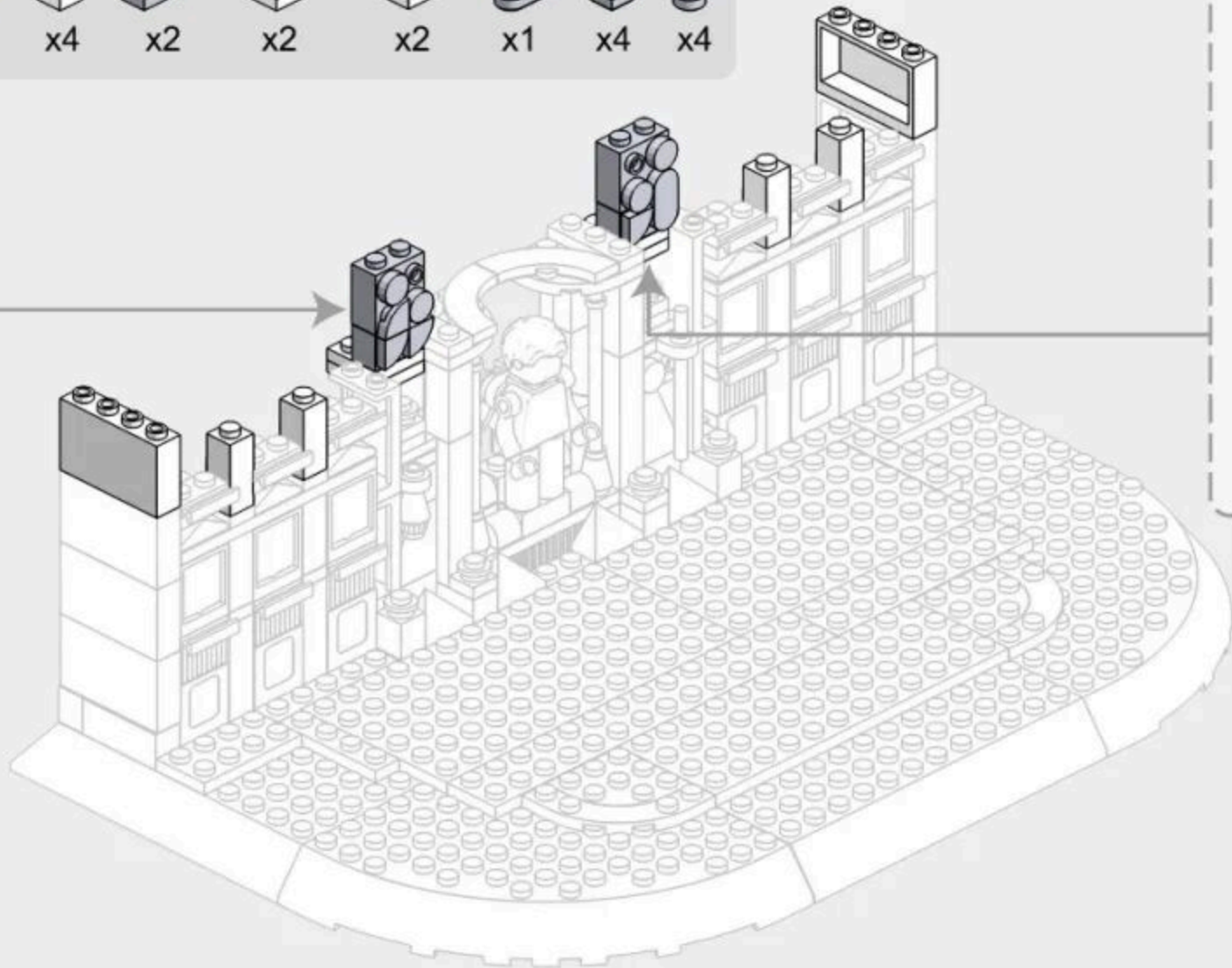
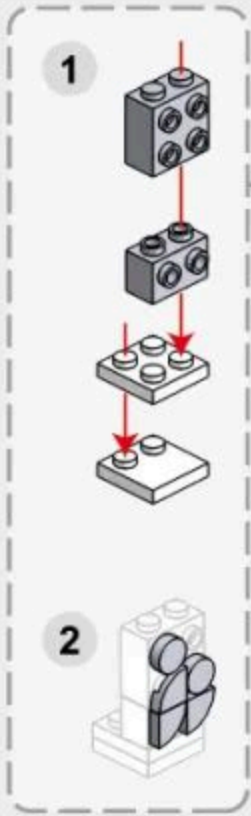

# 2-2

-  x6
-  x4
-  x6
-  x4
-  x4

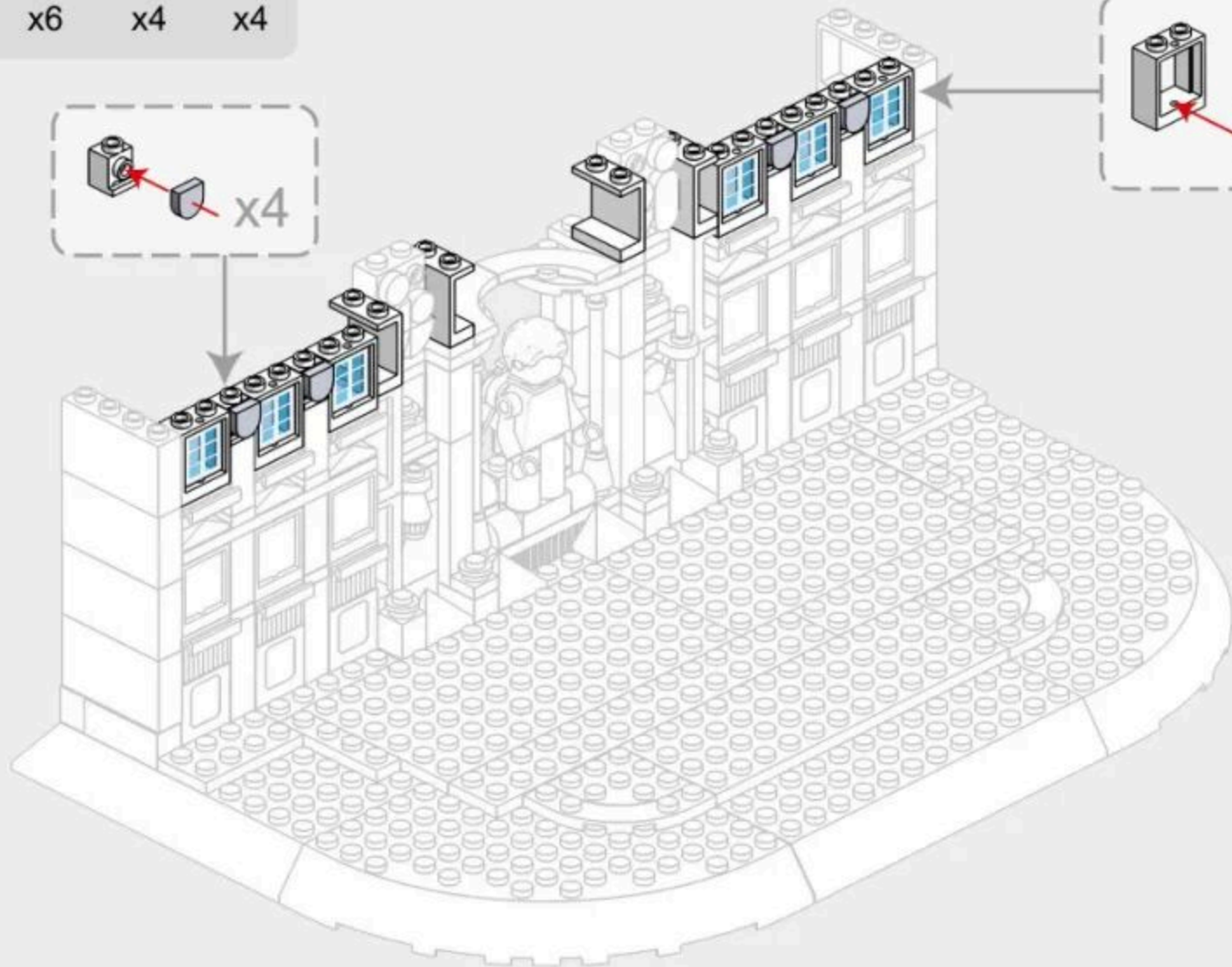
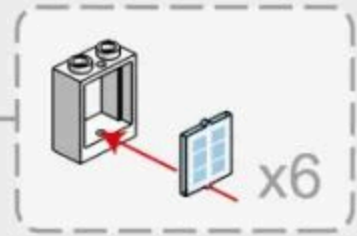
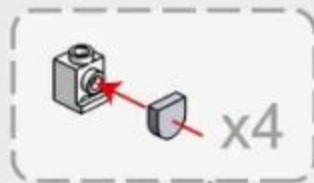

## 2-3

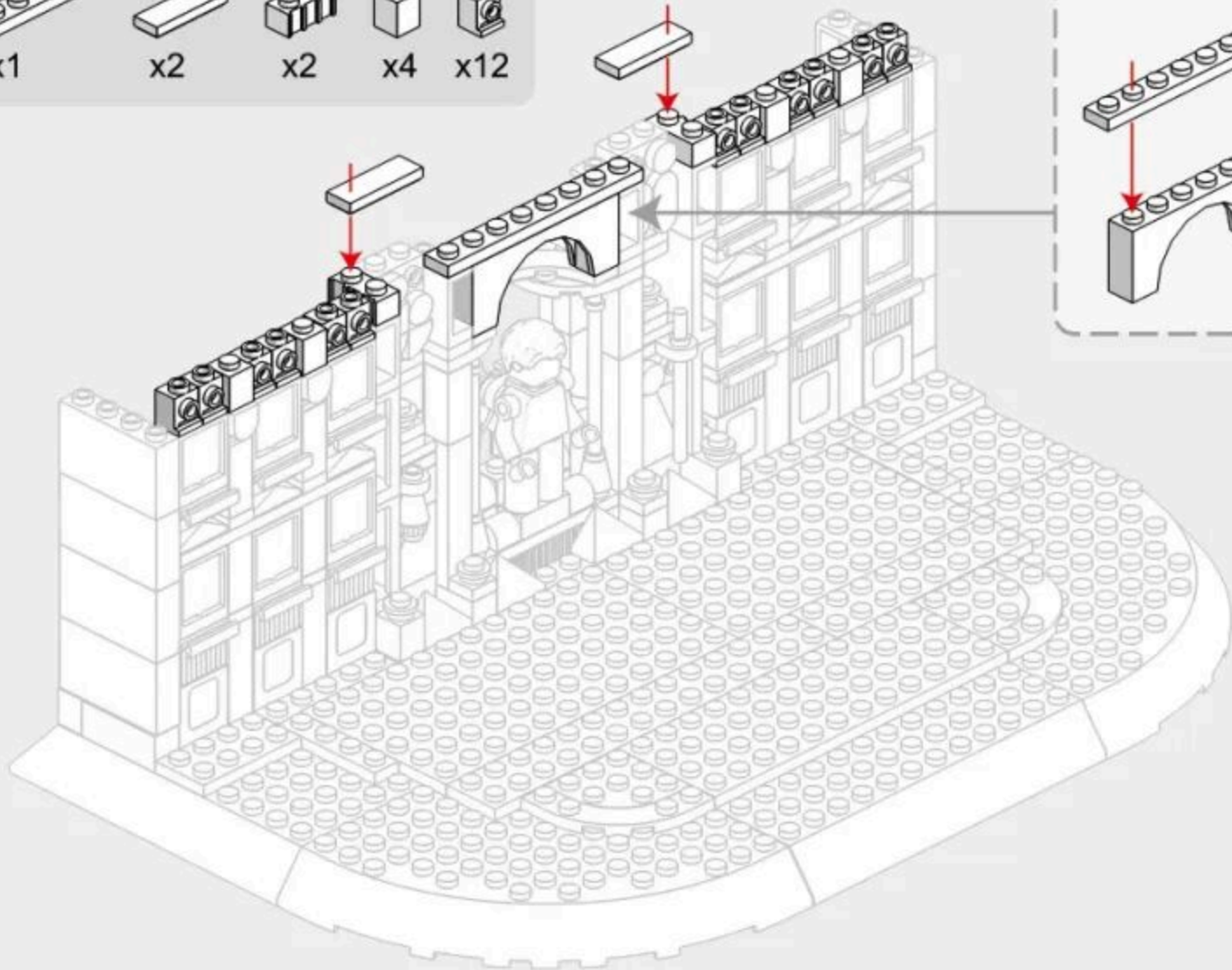
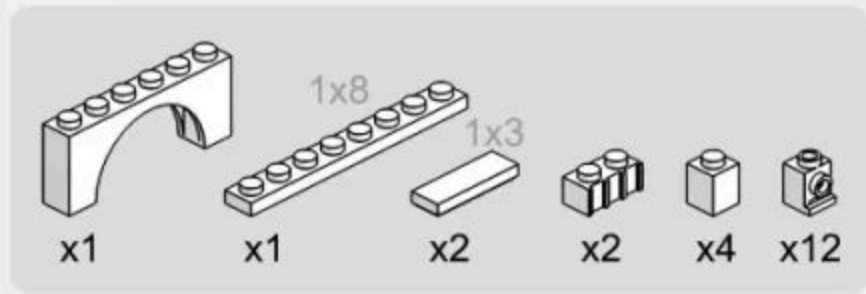

## 2-4

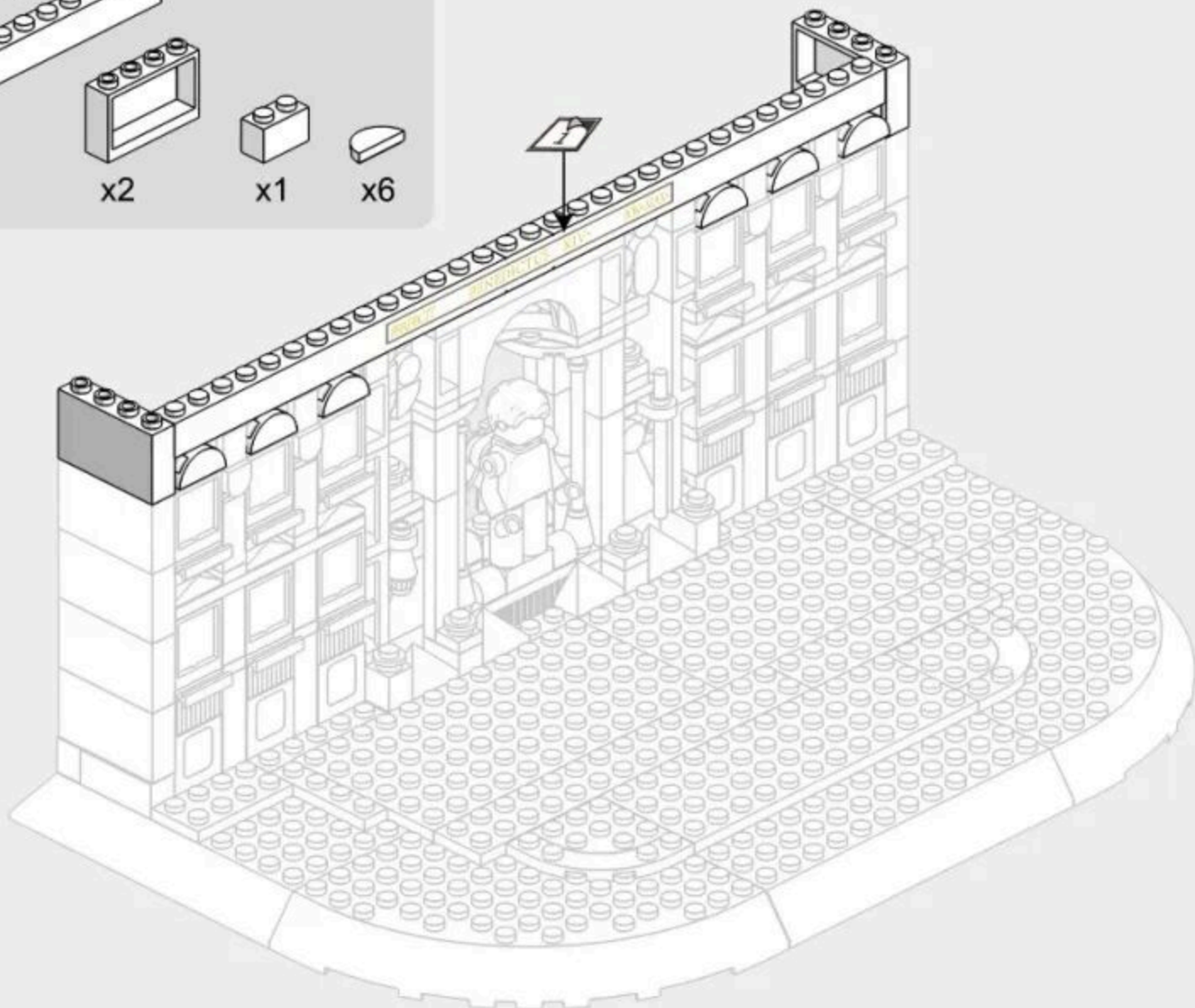
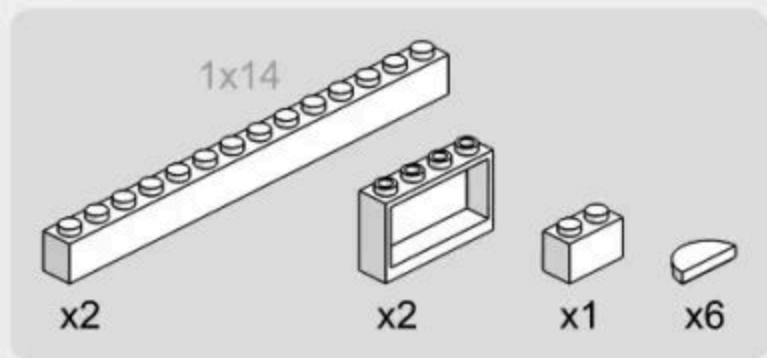

2-5

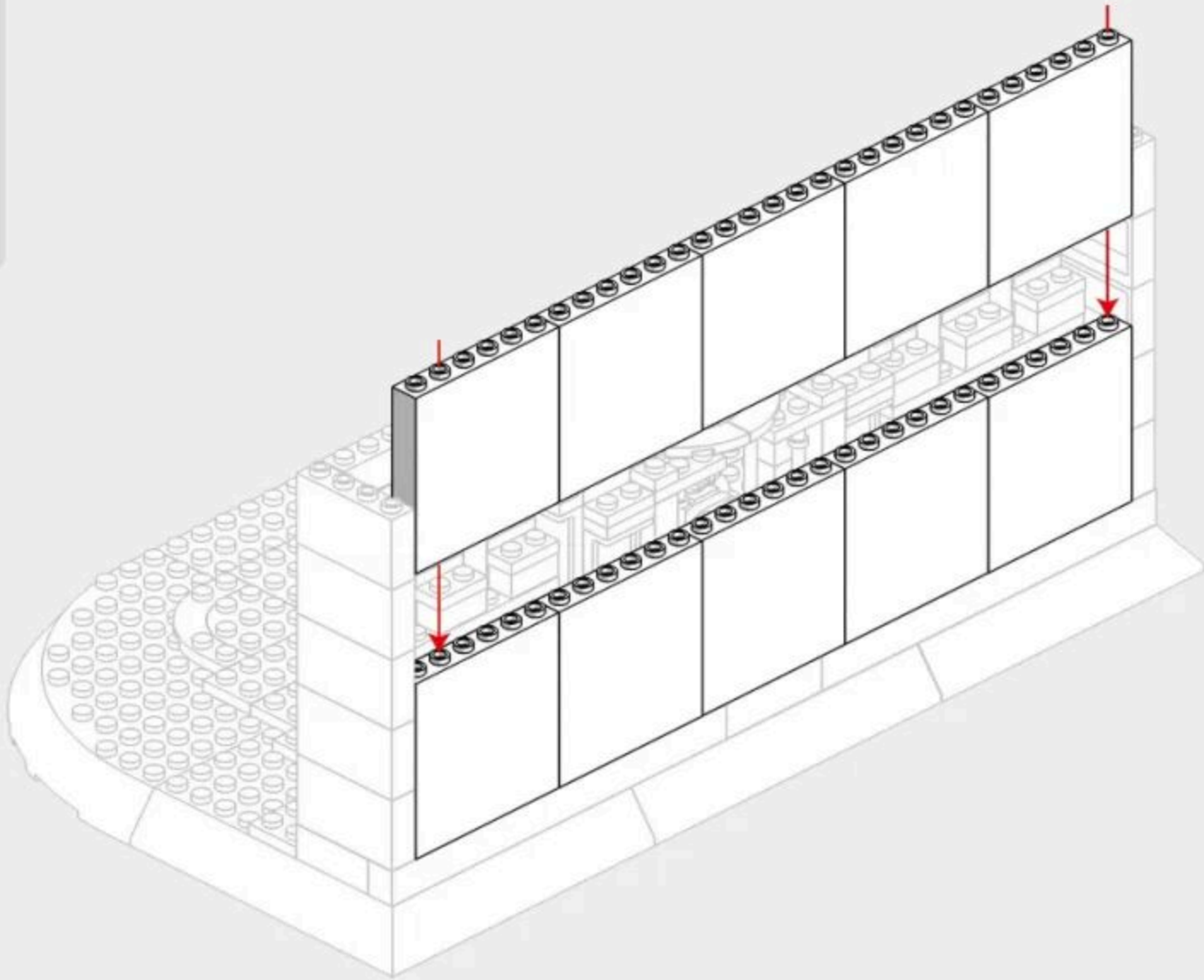
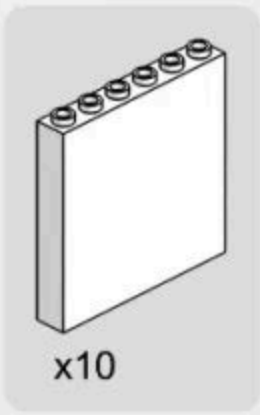

2-6

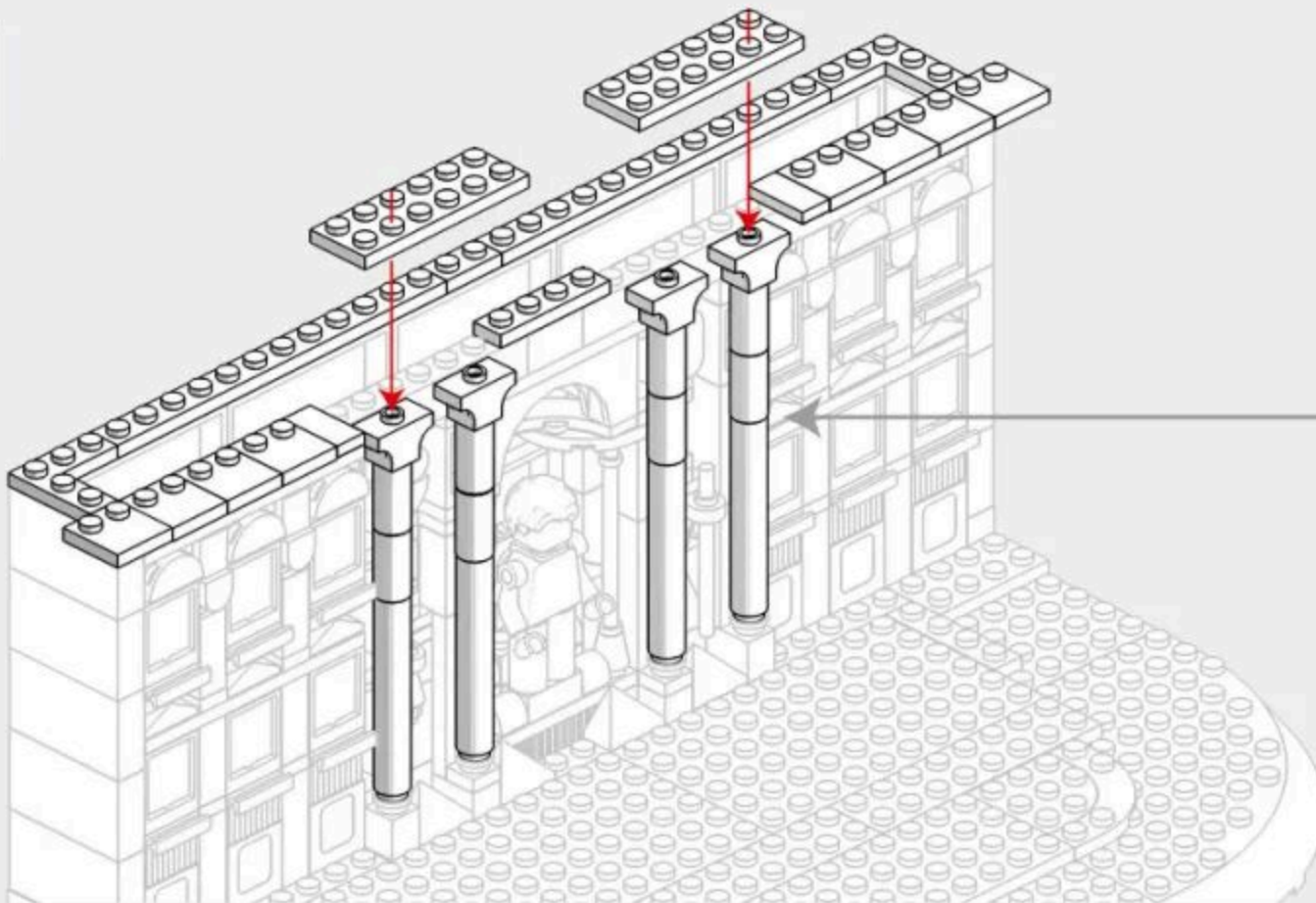
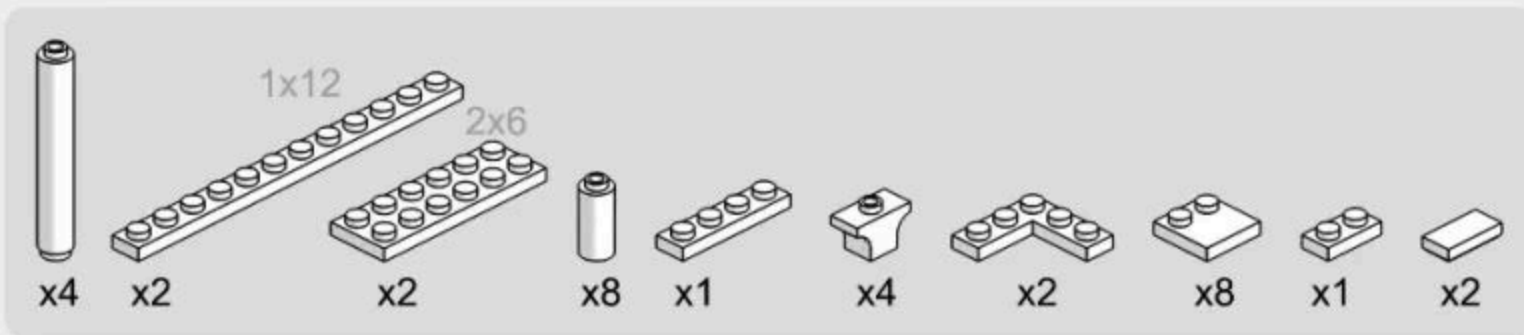

# 2-7

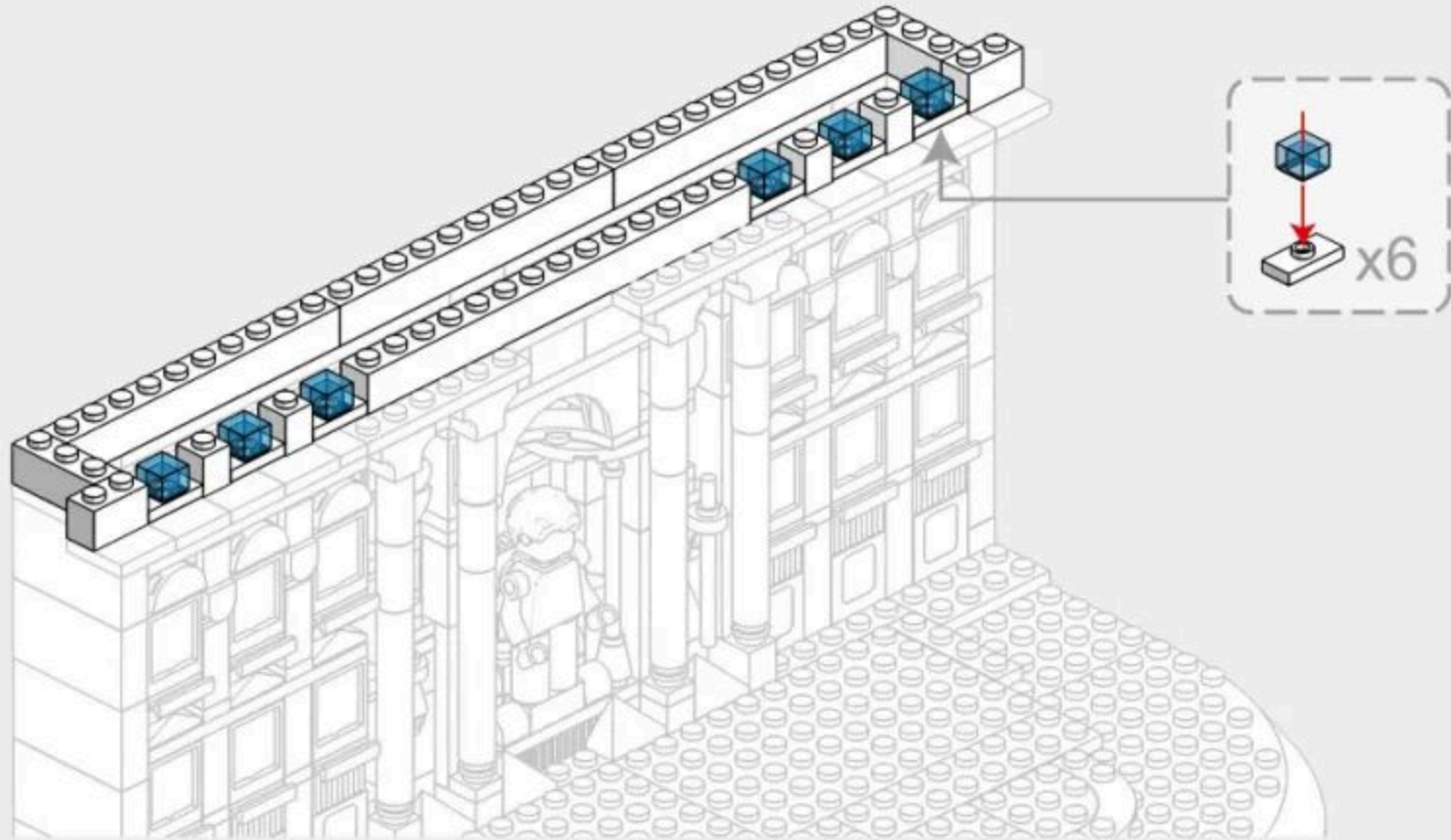
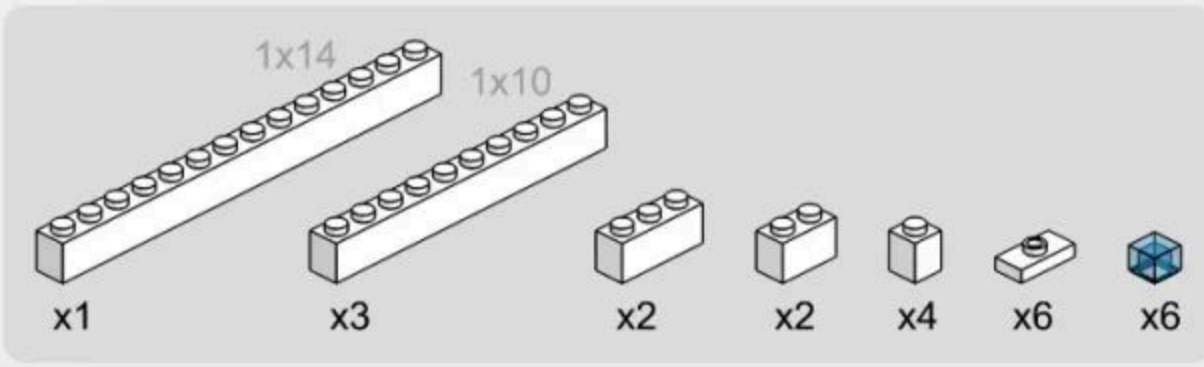

# 2-8

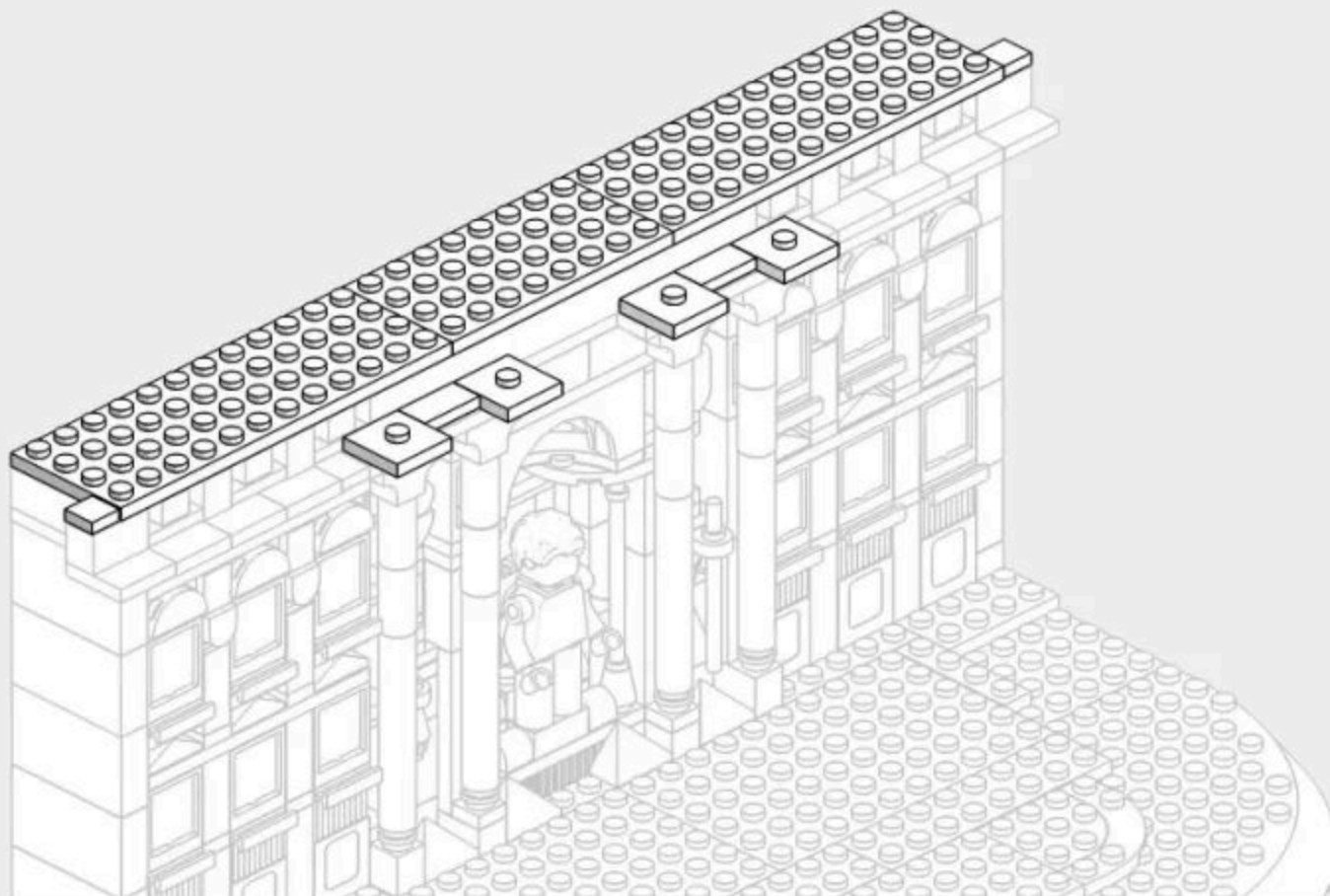
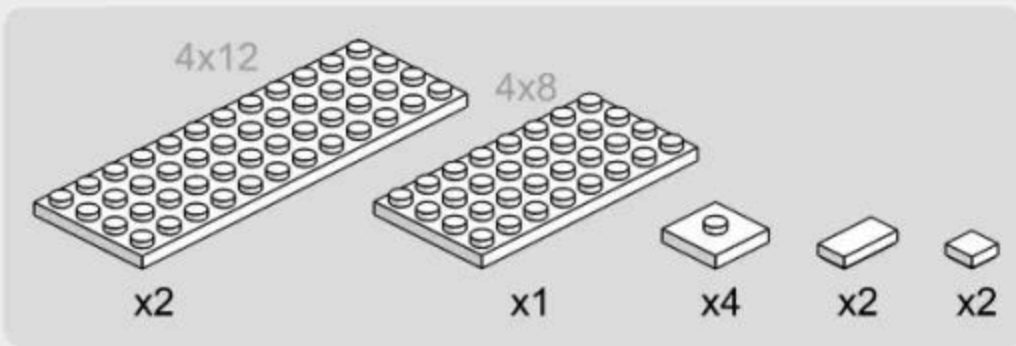

# 2-9

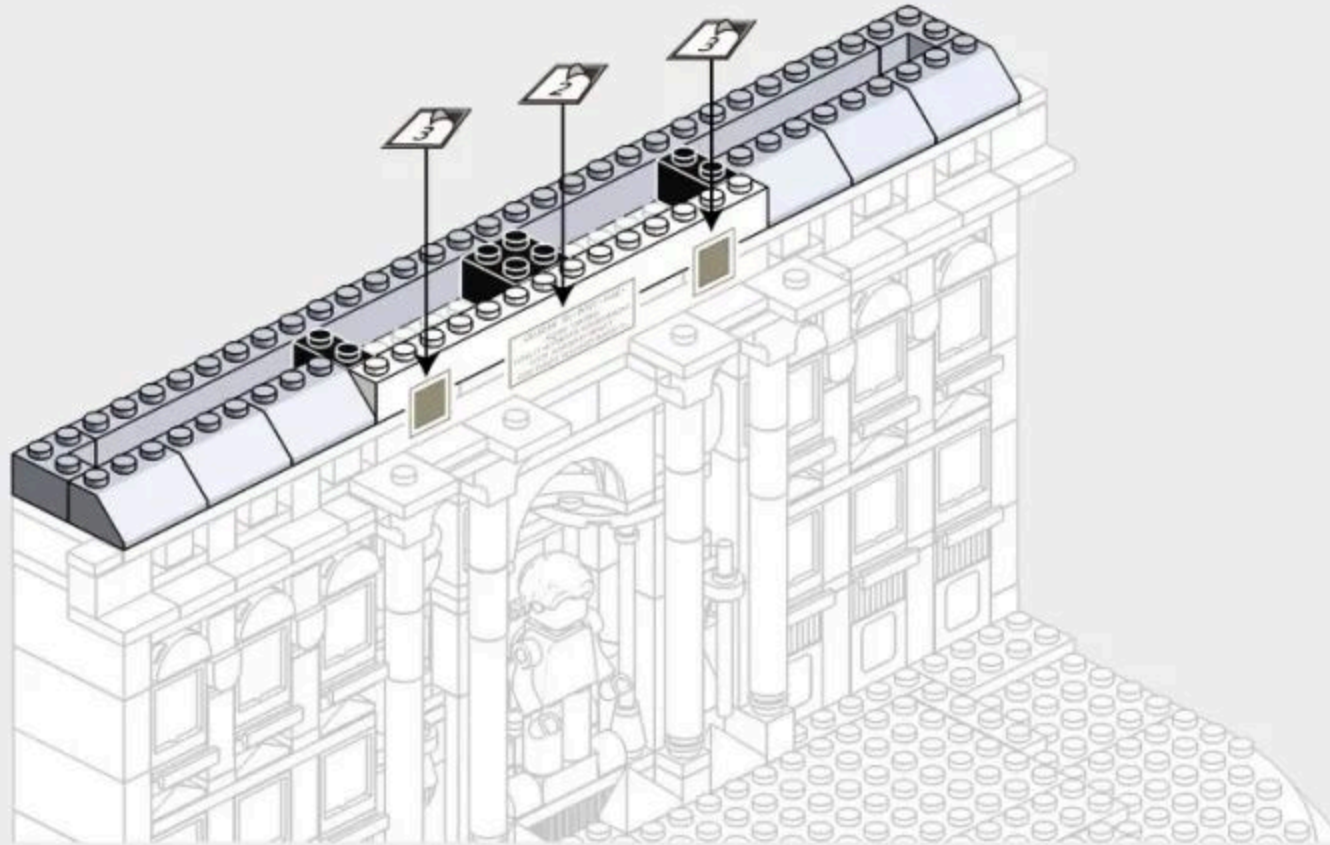
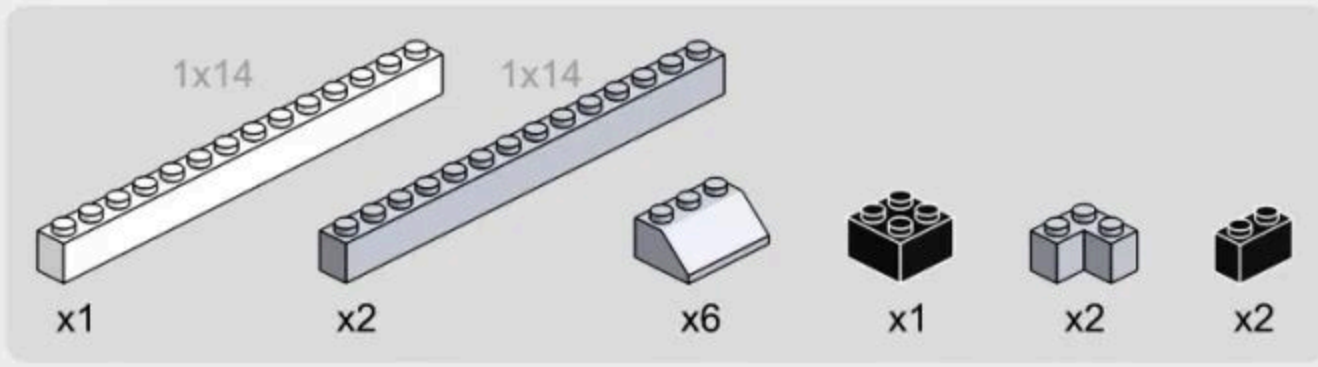

# 2-10

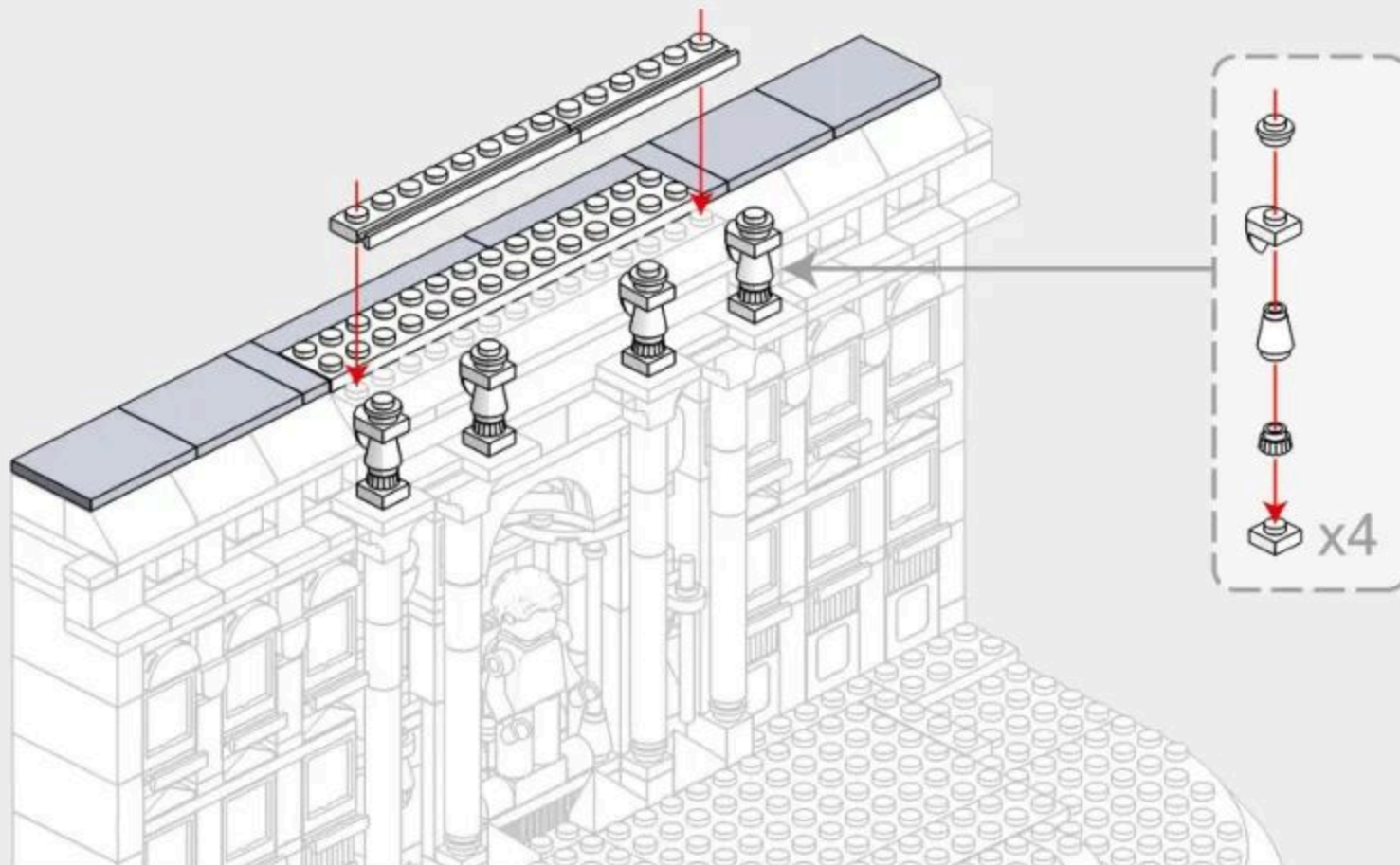
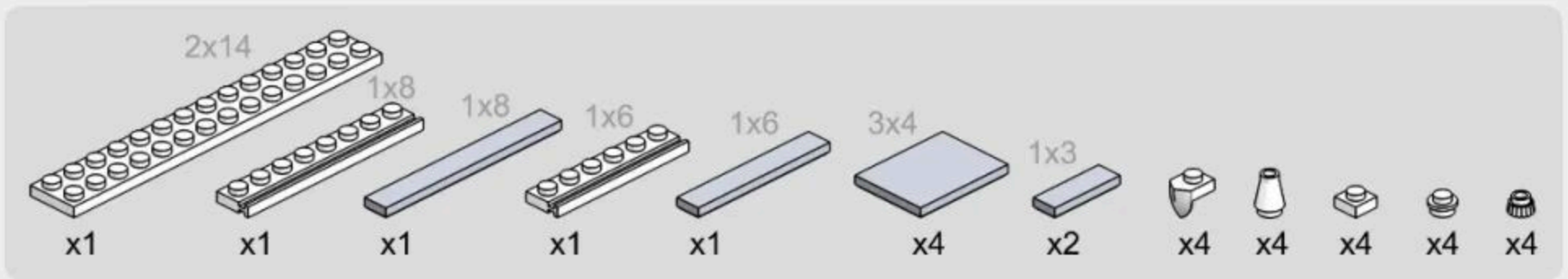

## 2-11

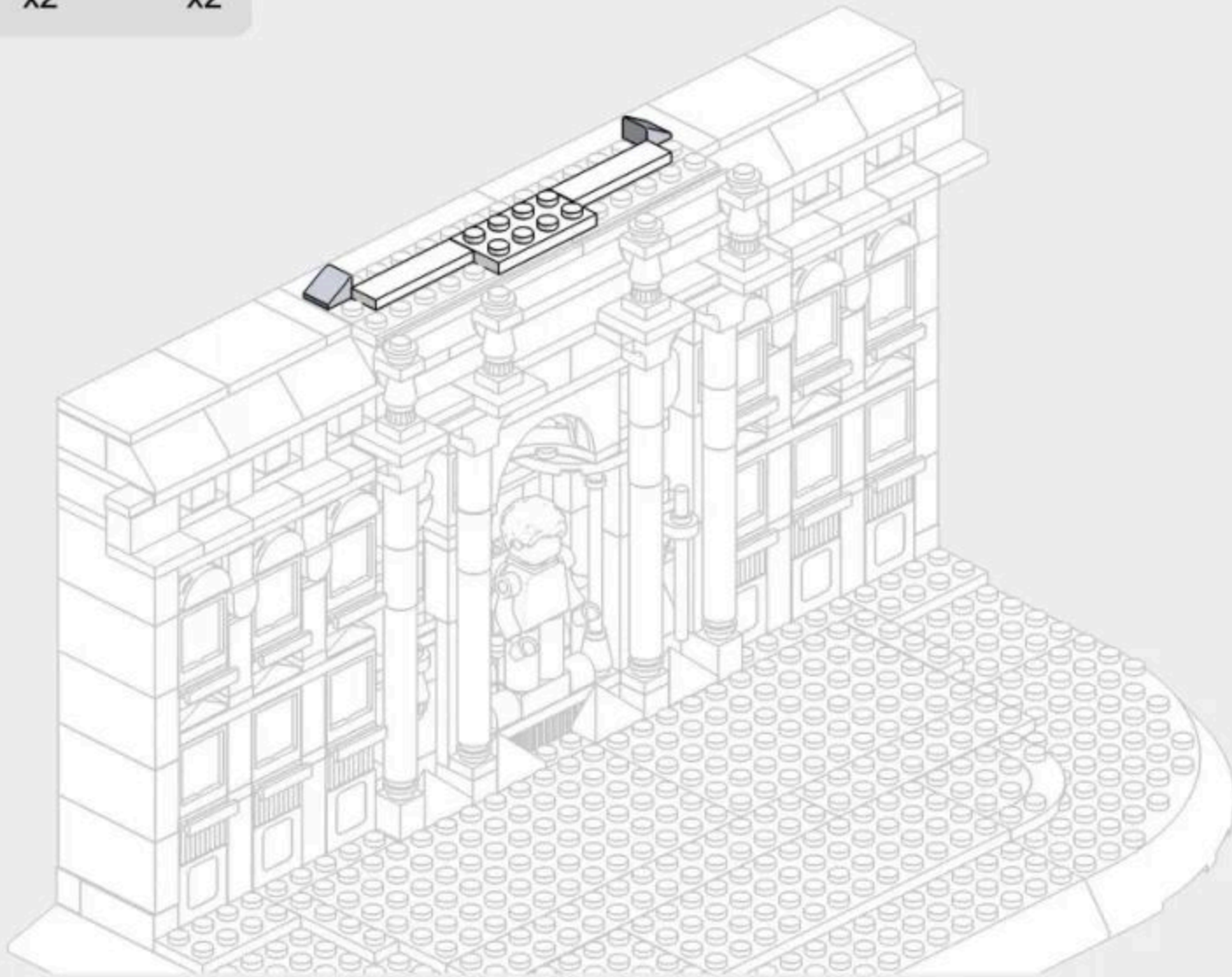
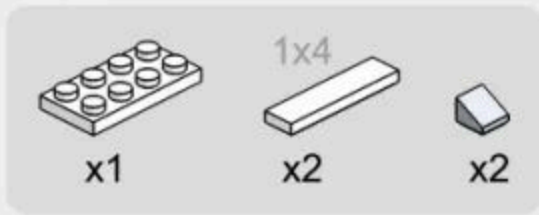

## 2-12

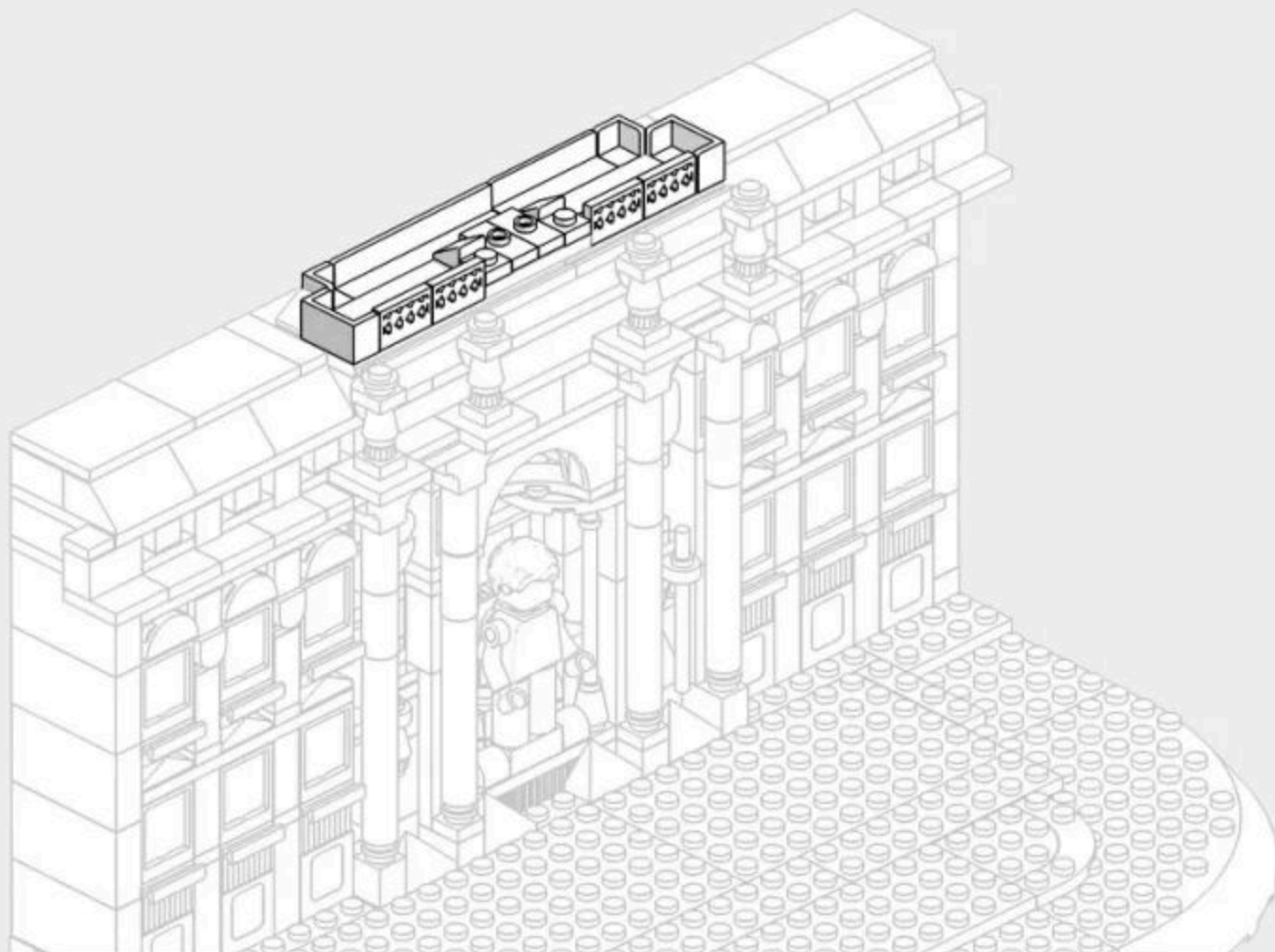

# 2-13

-  x1
-  x1
-  x1
-  x1
-  x2
-  x1
-  x2
-  x1
-  x2
-  x3

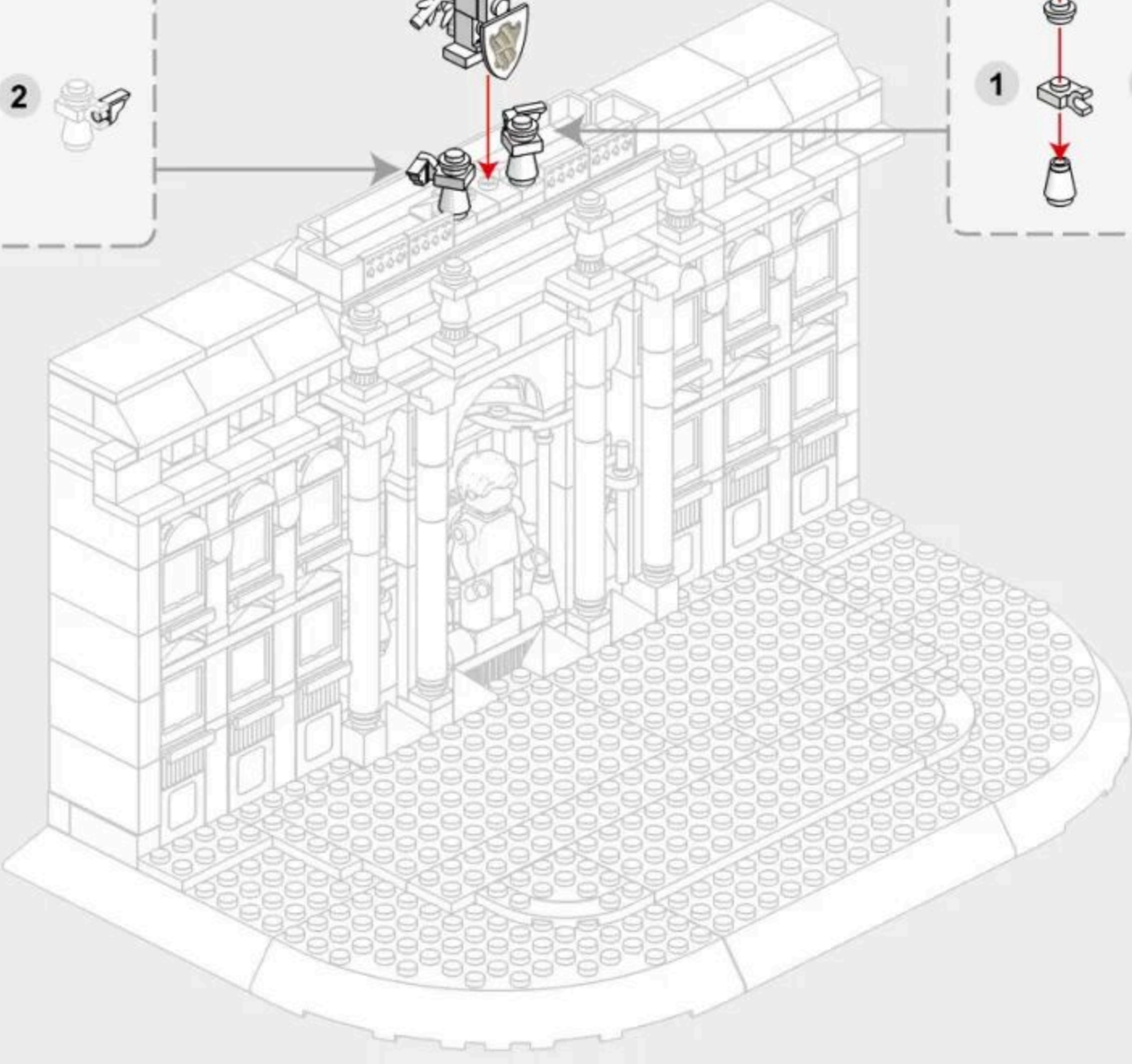
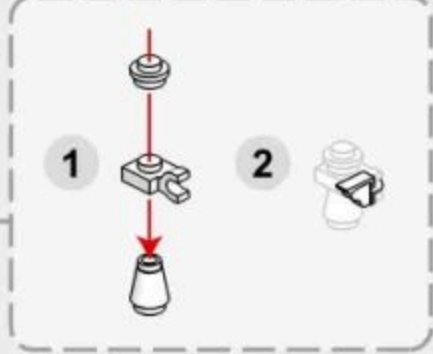
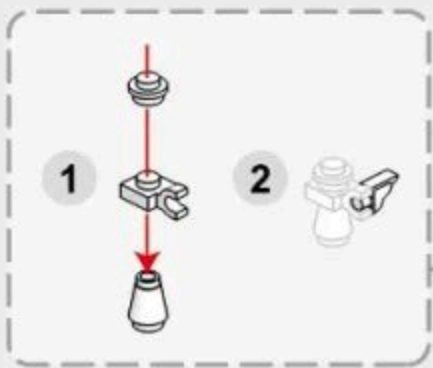
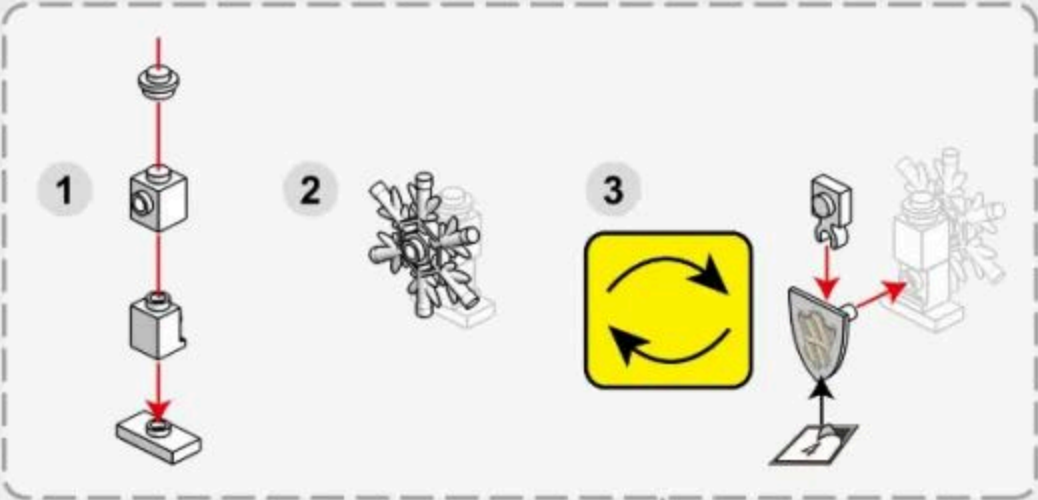



178PCS

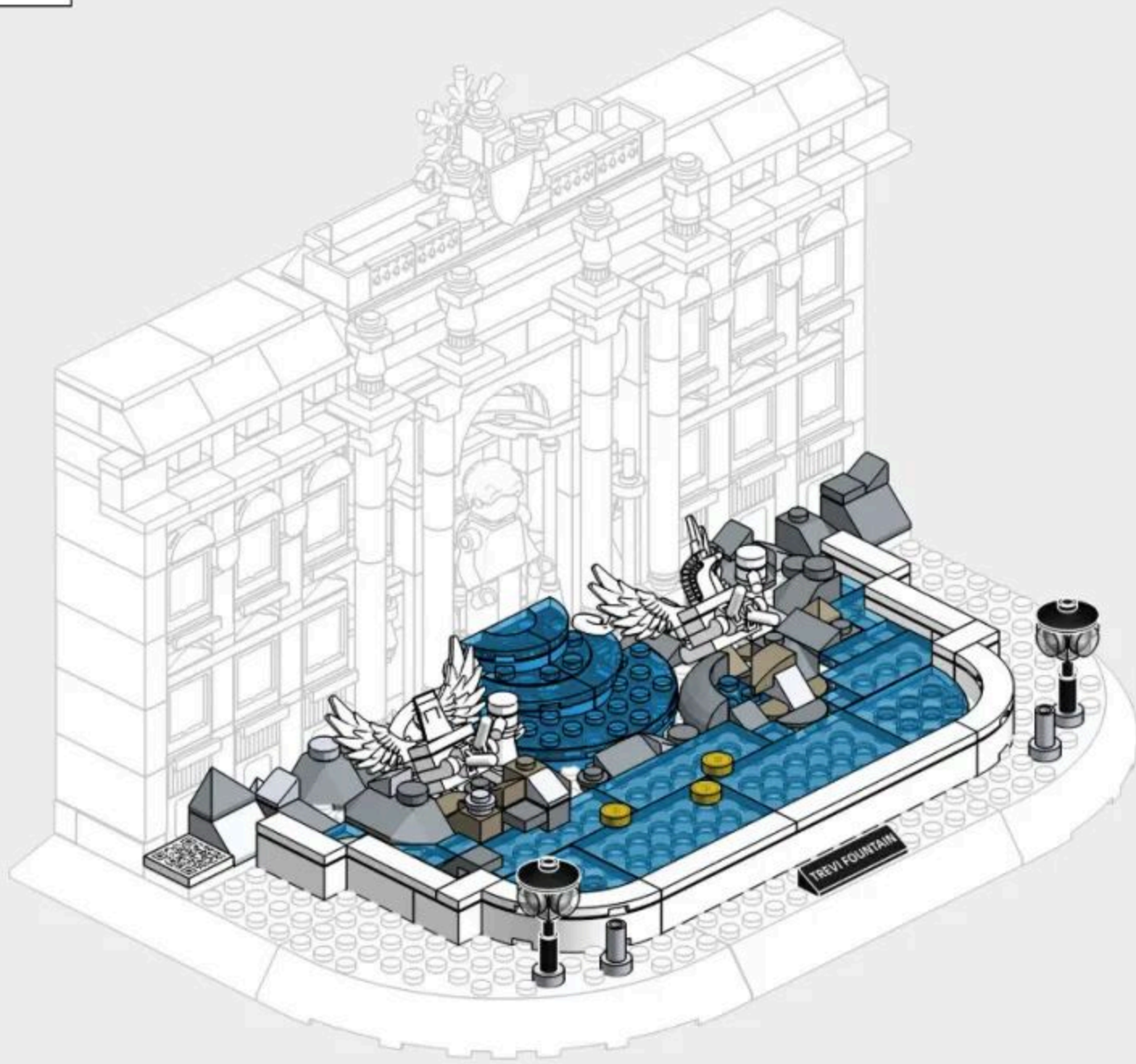

### 3-1

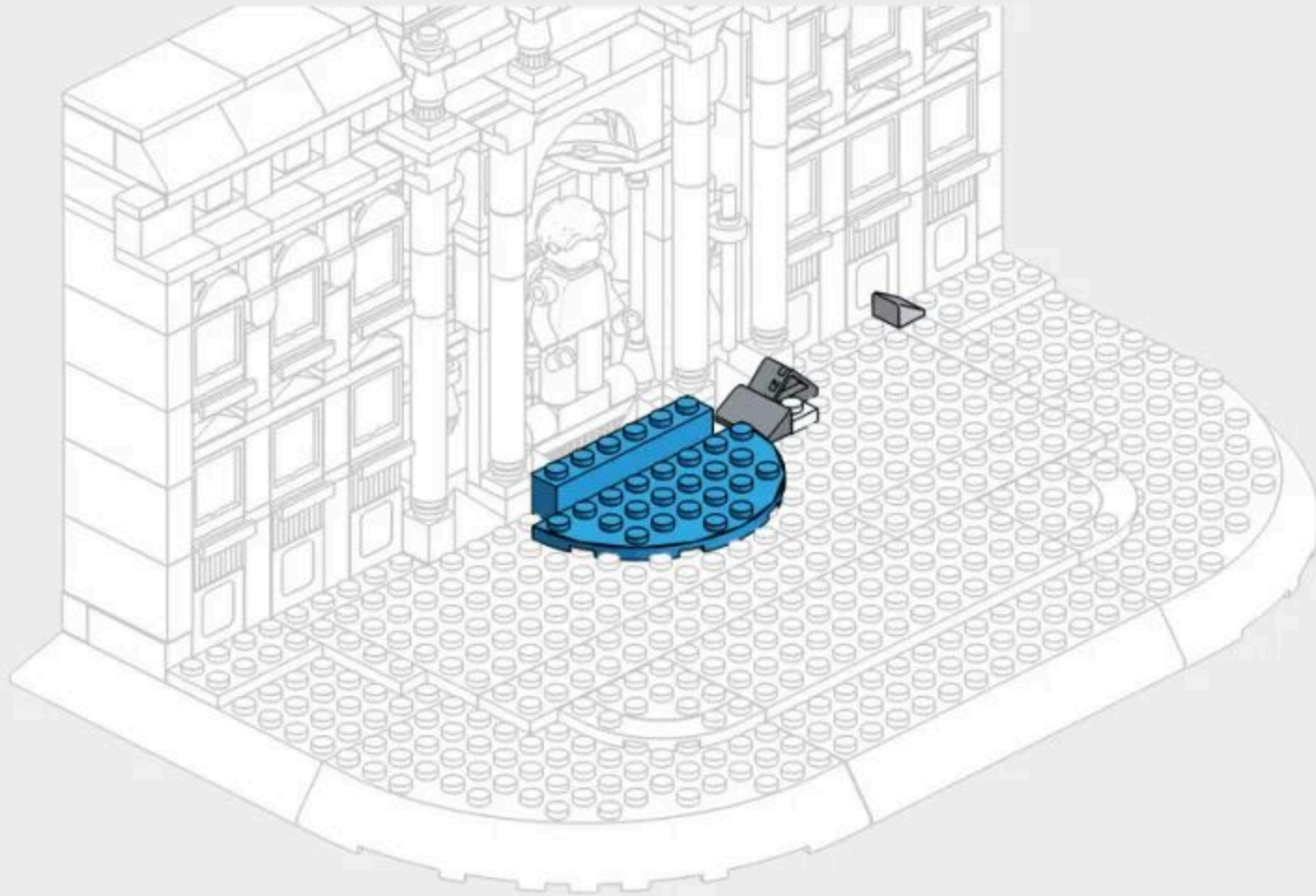
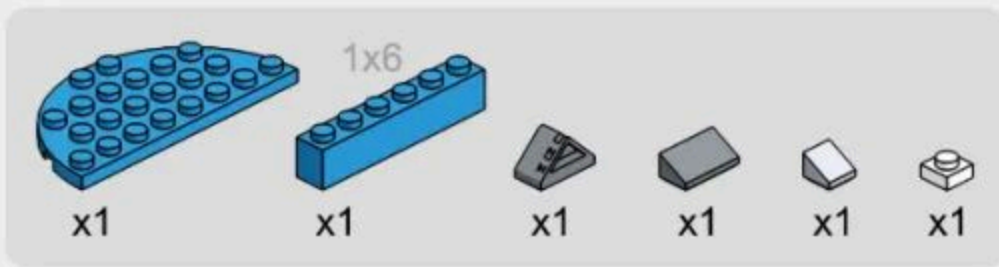

### 3-2

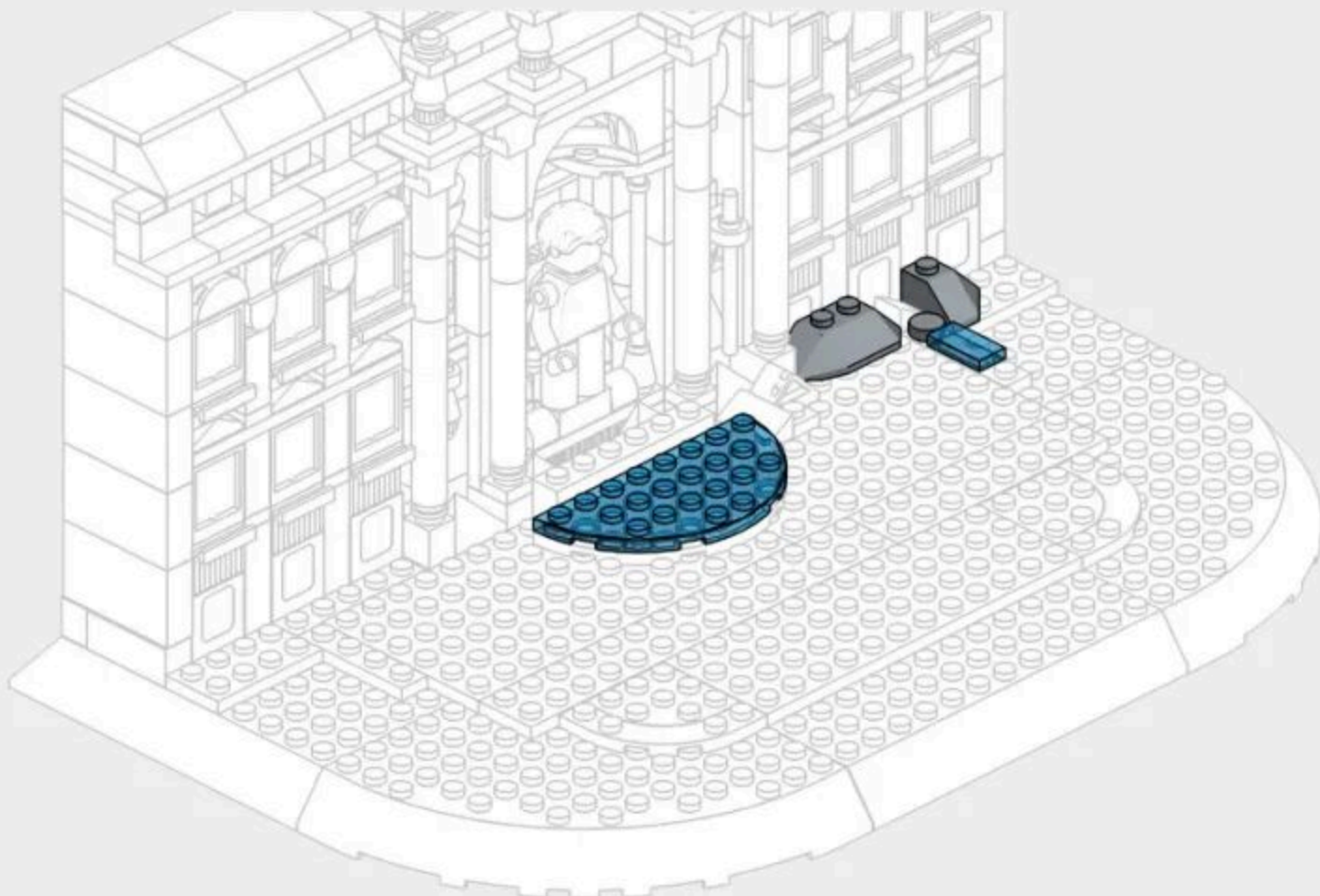

### 3-3



### 3-4

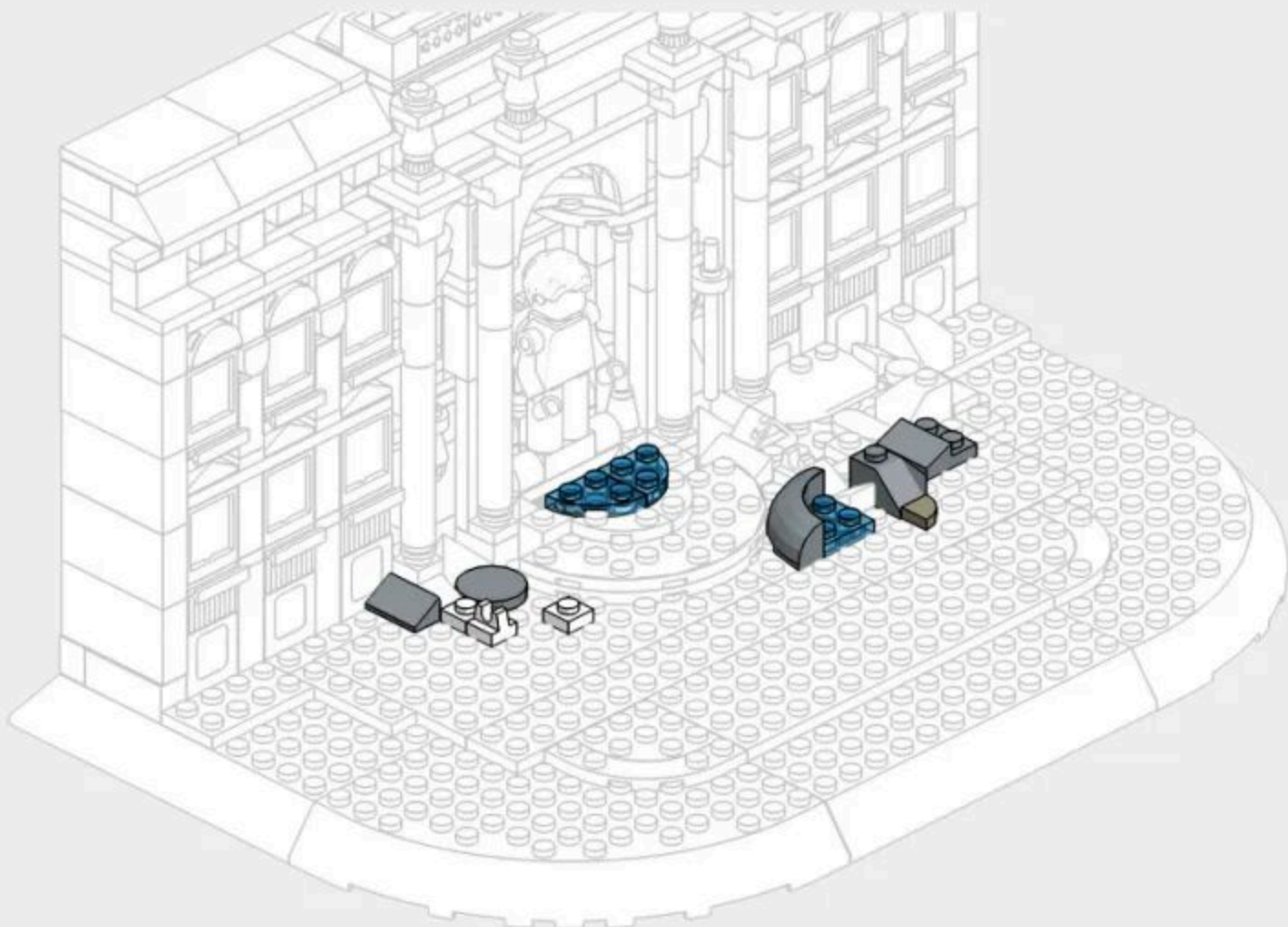



### 3-7

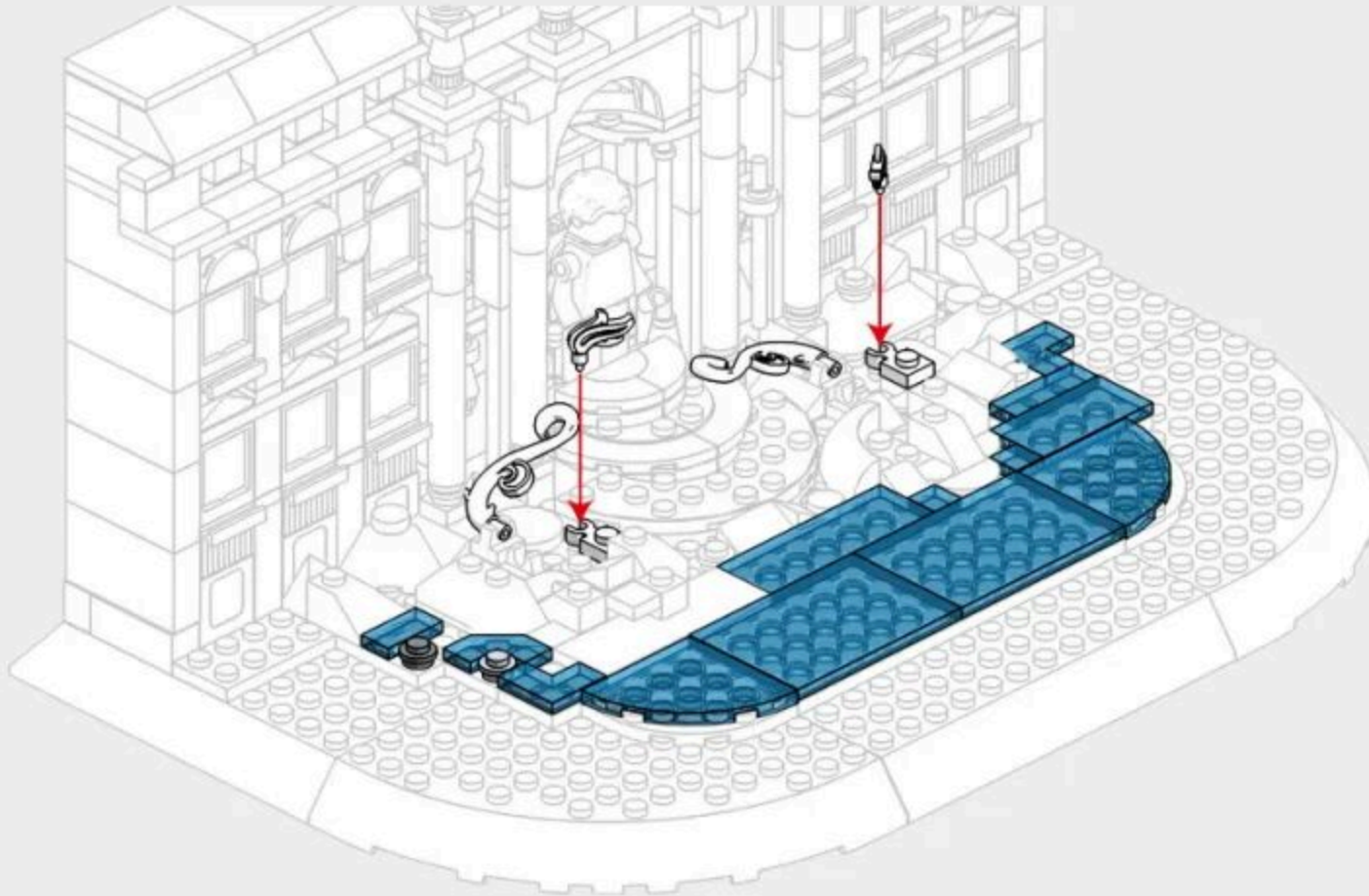
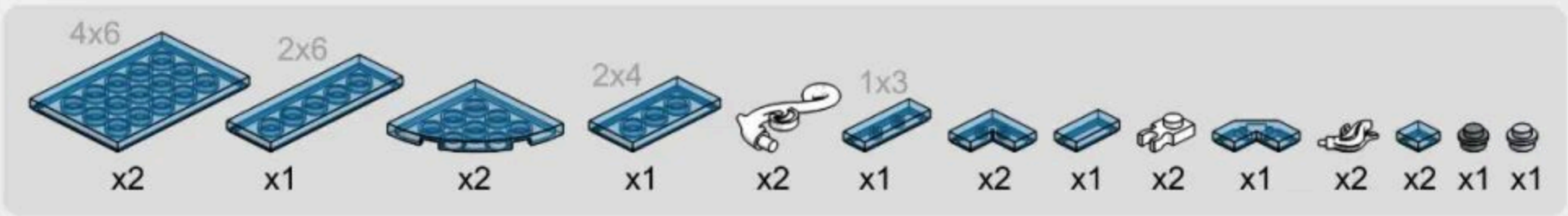

### 3-8



### 3-9

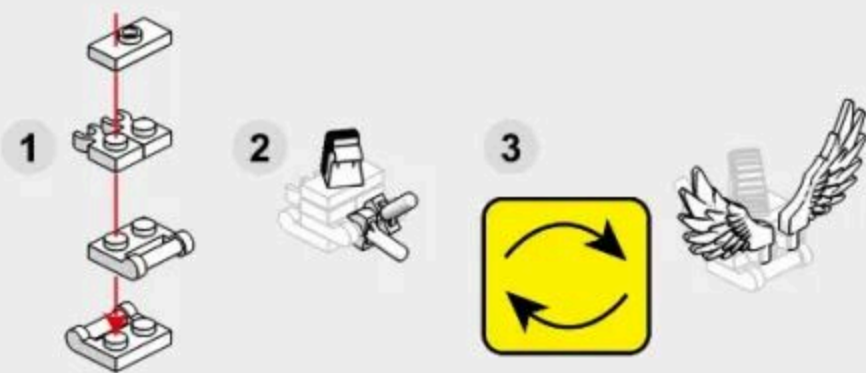

### 3-10

-  x2
-  x2
-  x2
-  x2

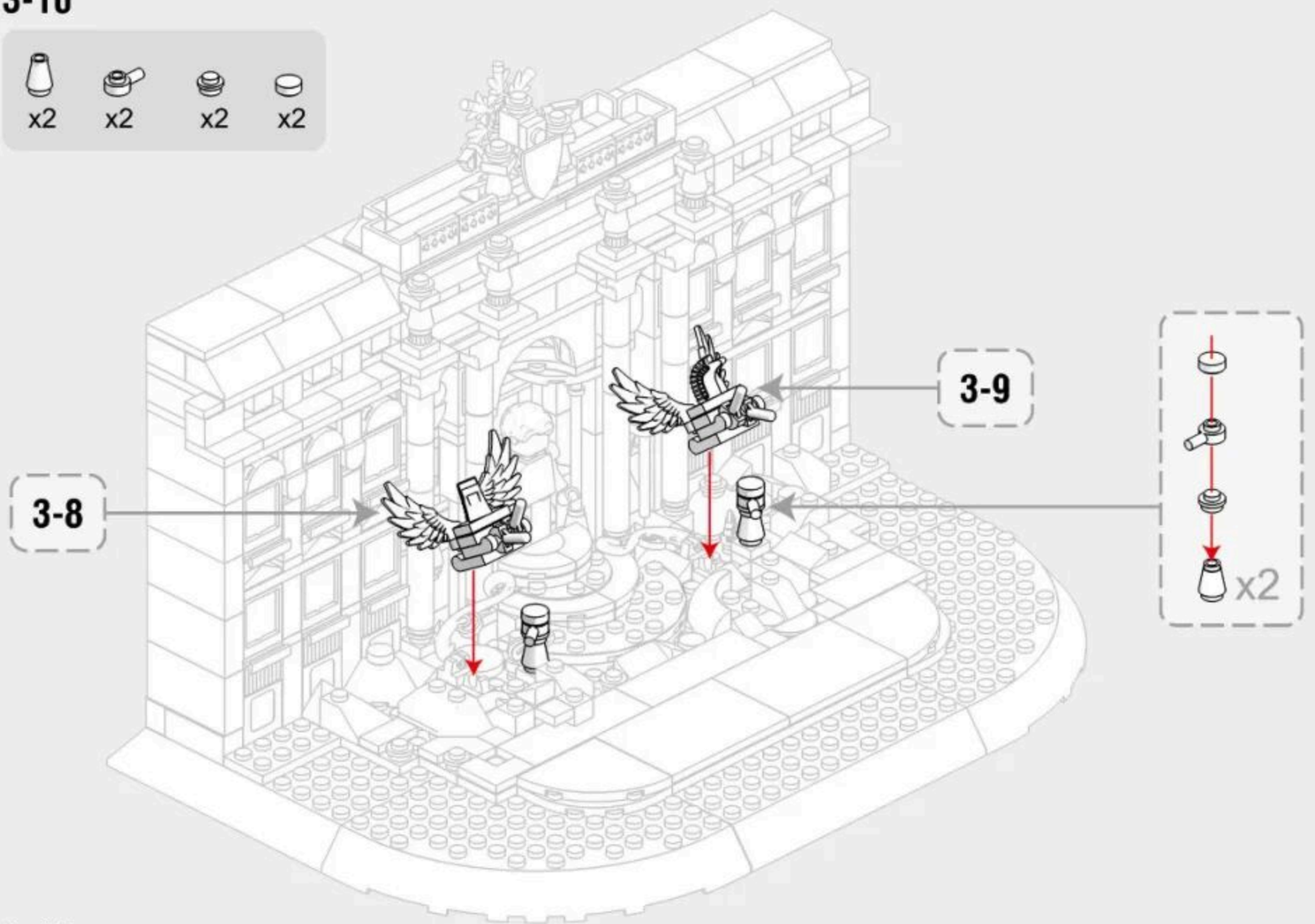

### 3-11

-  x1
-  x1
-  x1
-  x3
-  x1
-  x2

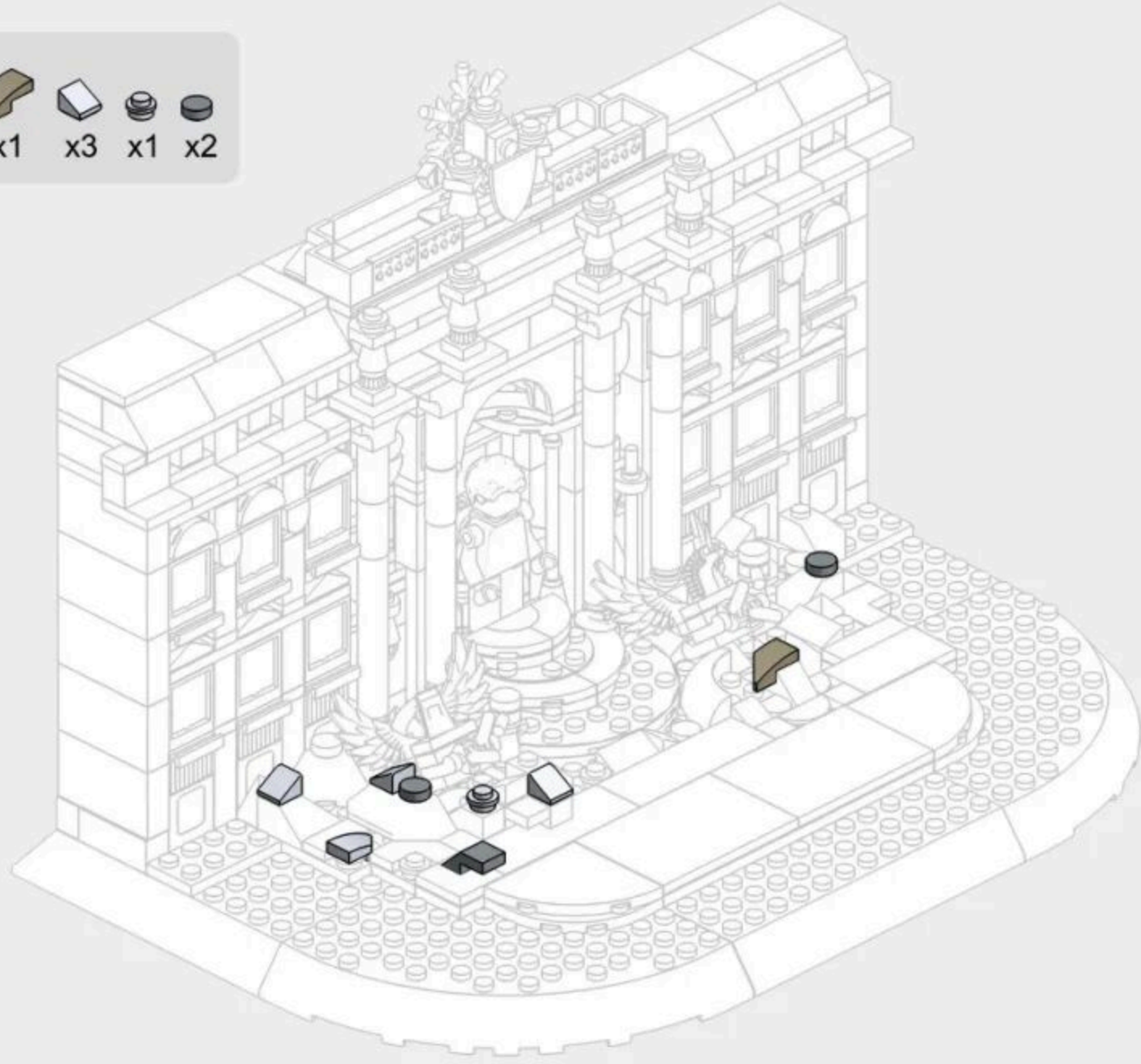

### 3-12

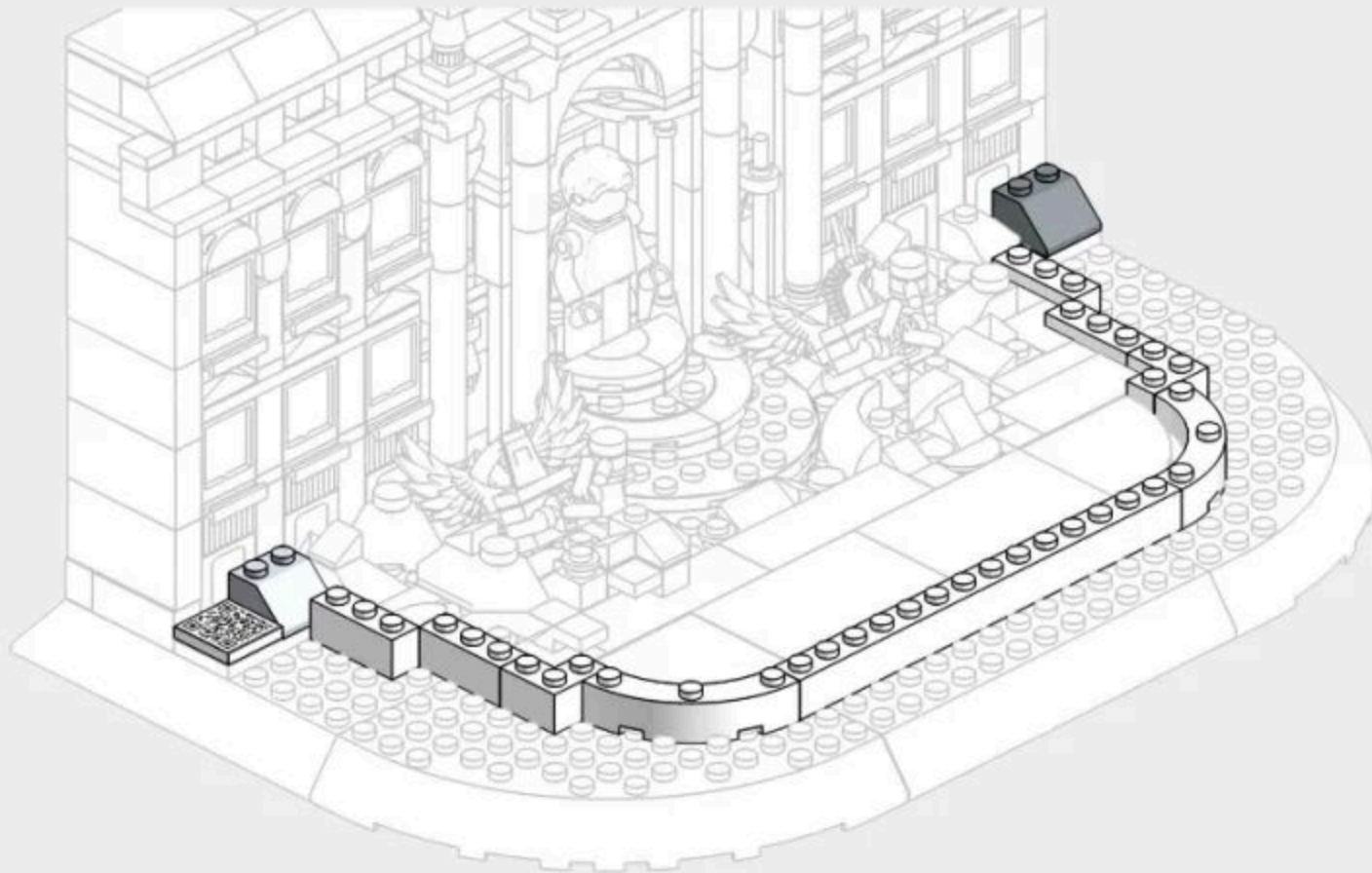
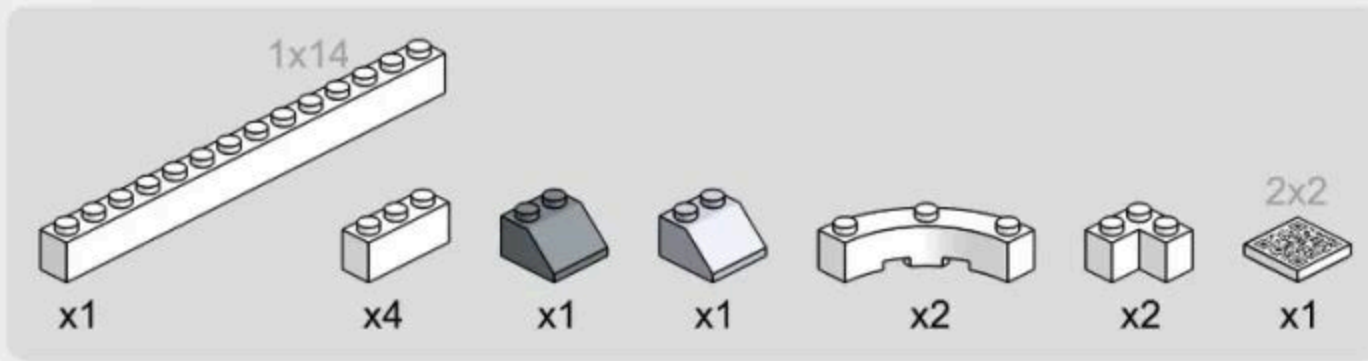

### 3-13

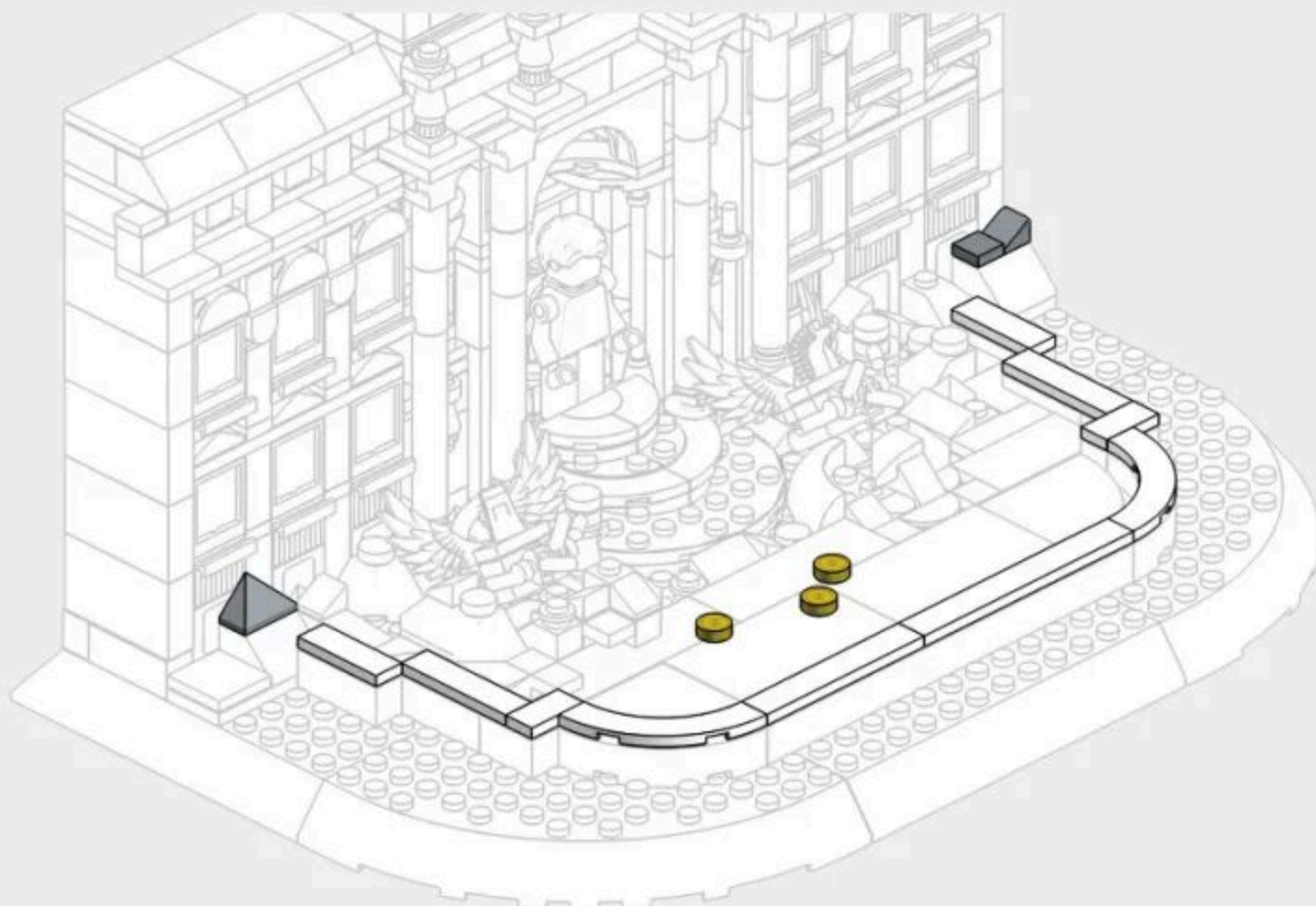

# 3-14

- TREVI FOUNTAIN x1
- Motor x2
- Pin x2
- Pin x2
- Pin x2
- Plate x2
- Pin x4
- Pin x8

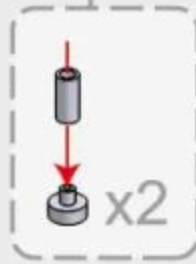
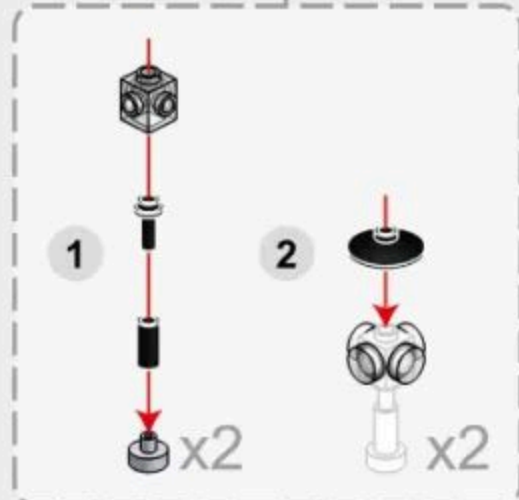
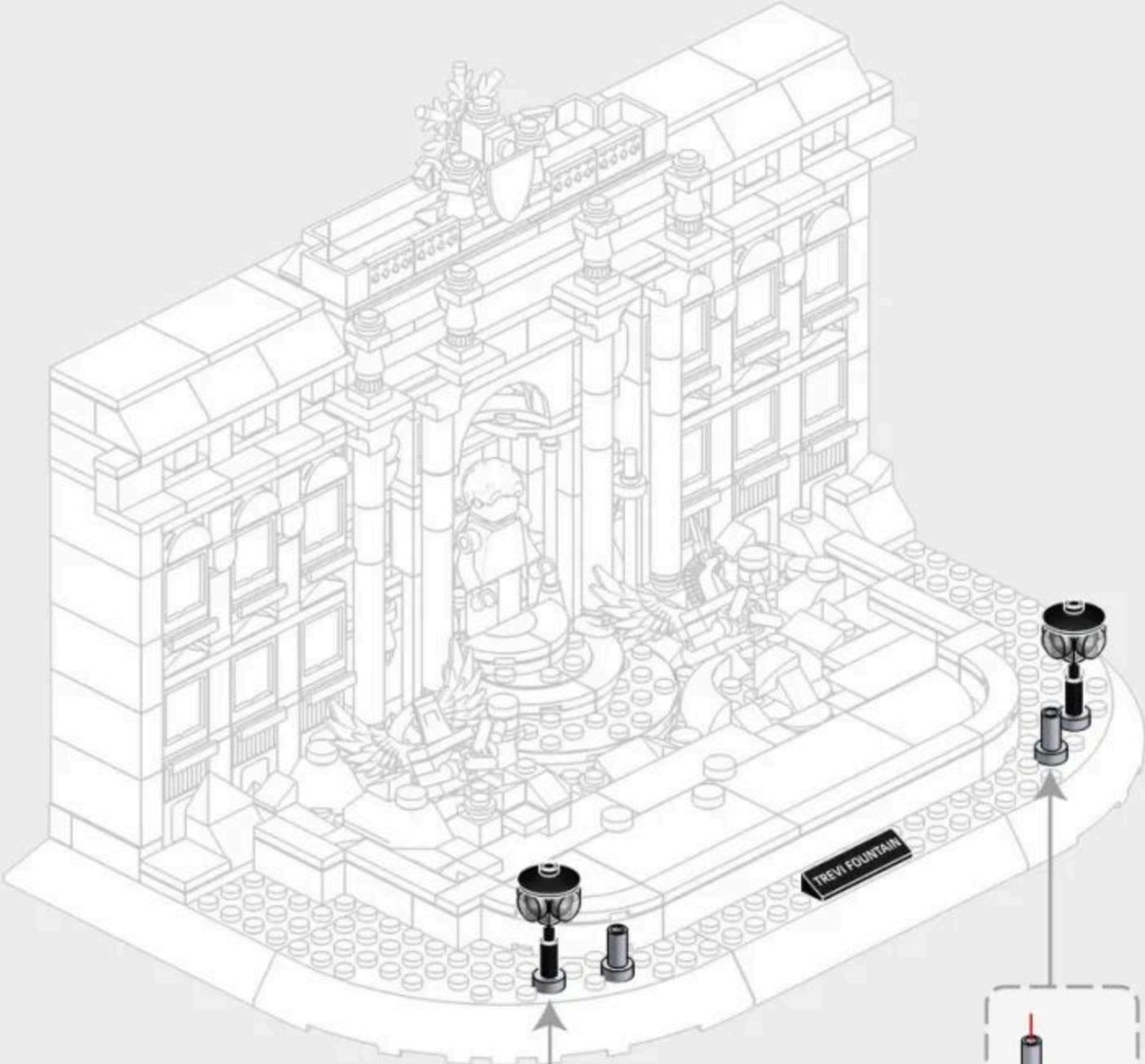

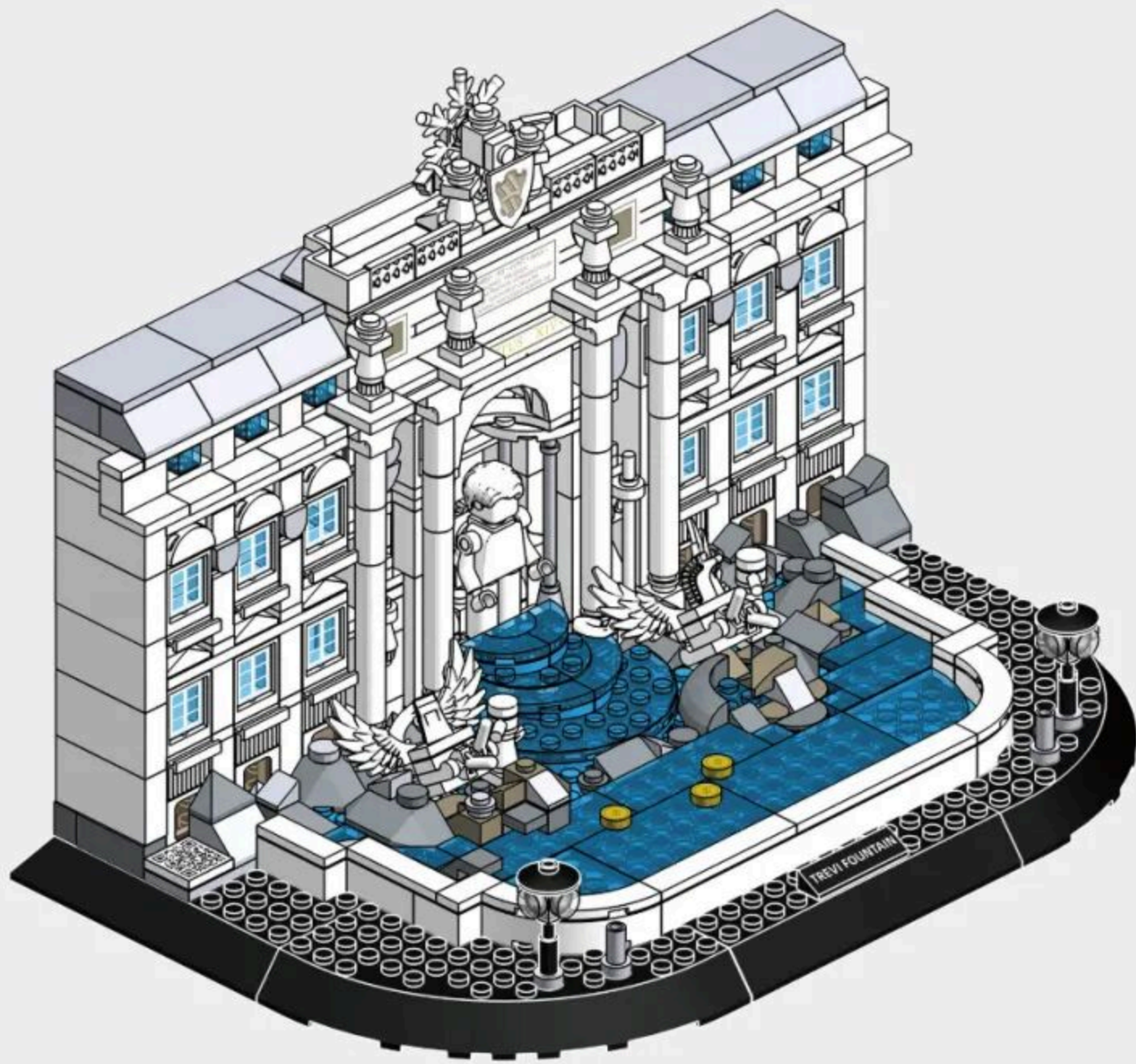

# ARCHITECTURE

The World's great architecture

- Shaping Skills
- Imagination & Curiosity
- Mathematical
- Self Discovery & Perception
- Parent-Child Interactions
- Problem Solving
- Creativity



6224 英国伦敦白金汉宫  
BUCKINGHAM PALACE-LONDON,ENGLAND



5225 意大利罗马斗兽场  
COLOSSEUM-ROME,ITALY



5226 日本东京帝国饭店  
IMPERIAL HOTEL-TOKYO,JAPAN



5227 美国纽约自由女神像  
STATUE OF LIBERTY-NEW YORK,AMERICA



6211 德国柏林勃兰登堡门  
BRANDENBURG GATE-BERLIN, GERMANY



6222 中国甘肃长城-嘉峪关  
JIAYU PASS-GANSU,CHINA



6212 日本京都清水寺仁王门  
NOMON GATE OF KIYOMIZU-DERA-KYOTO,JAPAN



6213 俄罗斯莫斯科瓦西里大教堂  
SAINT BASIL'S CATHEDRAL-MOSCOW,RUSSIA



6214 中国武汉黄鹤楼  
YELLOW CRANE TOWER-WUHAN,CHINA



6215 英国伦敦眼  
LONDON EYE-LONDON,ENGLAND



6221 中国北京故宫-太和殿  
HALL OF SUPREME HARMONY-BEIJING,CHINA



6220 沙特阿拉伯麦加大清真寺  
GREAT MOSQUE OF MECCA,SAUDI ARABIA



6219 美国纽约联合国大厦  
UNITED NATIONS HEADQUARTERS-NEW YORK,AMERICA



4214 美国华盛顿白宫  
WHITE HOUSE-WASHINGTON D.C.,AMERICA



4212 意大利罗马许愿池  
TREVI FOUNTAIN-ROME,ITALY



4213 法国巴黎卢浮宫  
MUSÉE DU LOUVRE-PARIS,FRANCE



4218 新加坡-鱼尾狮  
MERLION,SINGAPORE



4219 英国伦敦双子塔桥  
TOWER BRIDGE-LONDON,ENGLAND



4216 美国华盛顿林肯纪念馆  
LINCOLN MEMORIAL-WASHINGTON D.C.,AMERICA



4217 新加坡-金沙酒店  
MARINA BAY SANDS,SINGAPORE



4210 埃及开罗吉萨金字塔  
GREAT PYRAMID OF GIZA-CAIRO,EGYPT



4221 加拿大渥太华国会山庄  
PARLIAMENT BUILDINGS-OTTAWA,CANADA



4211 英国伦敦伊丽莎白塔  
ELIZABETH TOWER-ENGLAND



4215 加拿大多伦多电视塔  
THE CN TOWER-CANADA



4220 美国纽约熨斗大厦  
FLATIRON BUILDING-NEW YORK,AMERICA



4222 阿联酋迪拜哈利法塔  
THE BURJ KHALIFA TOWER-DUBAI, UAE



5224 中国上海东方明珠广播电视塔  
ORIENTAL PEARL TOWER-SHANGHAI, CHINA



5212 美国纽约帝国大厦  
EMPIRE STATE BUILDING-NEW YORK, AMERICA



5213 马来西亚吉隆坡石油双塔  
PETRONAS TWIN TOWERS-KUALA LUMPUR, MALAYSIA



5214 意大利托斯卡纳比萨斜塔  
LEANING TOWER OF PISA-TUSCANY, ITALY



5216 英国伦敦伊丽莎白塔  
ELIZABETH TOWER-LONDON, ENGLAND



5219 俄罗斯莫斯科克里姆林宫钟楼  
SPASSKAYA TOWER-MOSCOW, RUSSIA



5220 阿联酋迪拜卓美亚帆船酒店  
BURJ AL ARAB HOTEL-DUBAI, UAE



5217 法国巴黎埃菲尔铁塔  
EIFFEL TOWER-PARIS, FRANCE



5221 中国台北101大楼  
TAIPEI 101-TAIPEI, CHINA



5228 美国芝加哥威利斯大厦  
WILLIS TOWER-CHICAGO, AMERICA



5231 巴西里约热内卢救世基督像  
CRISTO REDENTOR-RIO DE JANEIRO, BRASIL



6223 中国武汉长江大桥  
WUHAN YANGTZE RIVER BRIDGE



5210 法国巴黎圣母院大教堂  
CATHÉDRALE NOTRE DAME DE PARIS-PARIS, FRANCE



5211 印度阿格拉泰姬陵  
TAJ MAHAL-AGRA, INDIA



5223 法国巴黎凯旋门  
ARC DE TRIOMPHE-PARIS, FRANCE



5215 英国伦敦双子塔桥  
TOWER BRIDGE-LONDON, ENGLAND



5222 中国北京天坛祈年殿  
HALL OF PRAYER FOR GOOD HARVESTS-BEIJING, CHINA



6210 美国旧金山金门大桥  
GOLDEN GATE BRIDGE-SAN FRANCISCO, AMERICA



6216 中国北京万里长城(八达岭)  
THE GREAT WALL-BEIJING, CHINA



5218 中国北京天安门  
TIANANMEN TOWER-BEIJING, CHINA



6217 中国西藏布达拉宫  
POTALA PALACE-TIBET, CHINA



6218 芬兰罗瓦涅米圣诞老人办公室  
SANTA CLAUS OFFICE-ROVANIEMI, FINLAND



6225 墨西哥库库尔坎玛雅金字塔  
EL CASTILLO-KUKULKAN, MEXICO



6226 德国巴伐利亚新天鹅堡  
SCHLOSS NEUSCHWANSTEIN-BAYERN, DEUTSCHLAND



5229 土耳其伊斯坦布尔少女塔  
MAIDEN TOWER-ISTANBUL, TURKEY



5230 中国湖南长沙爱晚亭  
AIWANTING PAVILION-HUNAN, CHINA



7210 中国上海世博会中国馆  
CHINA PAVILION AT EXPO-SHANGHAI, CHINA



5232 美国宾夕法尼亚州流水别墅  
FALLING WATER-PENNSYLVANIA, AMERICA



5233 美国芝加哥范斯沃斯住宅  
FARNSWORTH HOUSE-CHICAGO, AMERICA



5234 美国华盛顿唐人街  
CHINA TOWN-WASHINGTON, D.C., AMERICA



3210 美国纽约自由女神像  
STATUE OF LIBERTY-NEW YORK, AMERICA



4223 中国北京清华园  
TSINGHUA CAMPUS-BEIJING, CHINA



7211 中国湖南岳阳楼  
YUEYANG TOWER-HUNAN, CHINA



8210 澳大利亚悉尼歌剧院  
SYDNEY OPERA HOUSE-BENNELONG POINT, AUSTRALIA



7212 中国江西南昌滕王阁  
PAVILION OF PRINCE TENG-JIANGXI, CHINA



6227 中国河南郑州嵩山少林寺  
SHAOLIN TEMPLE-HENAN, CHINA



7213 中国重庆洪崖洞  
HONGYADONG-CHONGQING, CHINA



5235 美国华盛顿国会大厦  
UNITED STATES CAPITOL-WASHINGTON D.C., AMERICA



5236 中国安徽滁州醉翁亭  
ZUIWENG PAVILION-ANHUI, CHINA



6228 中国陕西西安钟楼  
XIAN BELL TOWER-SHAANXI, CHINA



5238 美国西雅图太空针塔  
SPACE NEEDLE-SEATTLE, AMERICA



5237 法国巴黎萨伏伊别墅  
VILLA SAVOYE-PARIS, FRANCE



6229 中国山西运城鹳雀楼  
STORK TOWER-SHANXI, CHINA



6230 希腊爱情海圣托里尼岛  
SANTORINI-FIRA, GREECE



6231 中国上海海关大楼  
SHANGHAI CUSTOMS HOUSE-SHANGHAI, CHINA



5239 中国北京紫禁城角楼  
TURRET OF PALACE MUSEUM-BEIJING, CHINA



5240 韩国首尔崇礼门  
NAMDAEMUN-SEOUL, KOREA



5241 中国江苏南京夫子庙  
CONFUCIUS TEMPLE-JIANGSU, CHINA



5242 美国纽约古根海姆博物馆  
GUGGENHEIM MUSEUM-NEW YORK, AMERICA



6232 中国江苏南京秦淮河画舫  
QINHUAI RIVER PAINTED BOAT-JIANGSU, CHINA



6233 法国诺曼底圣米歇尔山  
SAINT MICHAEL'S MOUNT-NORMANDY, FRANCE



6234 中国河南洛阳栾川老君山  
THE LAOJUN MOUNTAIN-HENAN, CHINA



5243 耶路撒冷岩石圆顶  
DOME OF THE ROCK-JERUSALEM



6235 中国江苏苏州寒山寺 (普明宝塔)  
HANSHAN TEMPLE-JIANGSU, CHINA



4224 英国威尔特郡巨石阵  
STONEHENGE-WILTSHIRE, ENGLAND



4225 中国内蒙古自治区蒙古包  
MONGOLIAN YURT-INNER MONGOLIA, CHINA



8211 中国福建土楼(承启楼)  
CHENGQI EARTH BUILDING-FUJIAN, CHINA



4226 沙特阿拉伯麦加大清真寺(克尔白)  
KERBAL, GREAT MOSQUE OF MECCA, SAUDI ARABIA



5244 俄罗斯圣彼得堡冬宫  
WINTER PALACE-ST.PETERSBURG, RUSSIA



7214 中国陕西西安鼓楼  
XI'AN DRUM TOWER-SHAANXI, CHINA



5245 中国重庆李子坝站  
LIZIBA STATION-CHONGQING, CHINA



4227 俄罗斯莫斯科国立大学  
MOSCOW STATE UNIVERSITY-MOSCOW, RUSSIA



4228 沙特阿拉伯麦地那先知清真寺  
PROPHET'S MOSQUE-MEDINA, SAUDI ARABIA



6236 中国浙江杭州雷峰塔  
LEIFENG PAGODA-HANGZHOU, ZHEJIANG, CHINA



5246 美国芝加哥罗宾别墅  
ROBIE HOUSE-CHICAGO, AMERICA



5247 中国陕西西安大雁塔  
GIANT WILD GOOSE PAGODA-SHAANXI, CHINA



5249 英国伦敦特拉法加广场  
TRAFALGAR SQUARE-LONDON, ENGLAND



5248 美国纽约洛克菲勒中心  
ROCKEFELLER CENTER-NEW YORK, AMERICA



5250 美国芝加哥约翰汉考克中心  
JOHN HANCOCK CENTER-CHICAGO, AMERICA



# TREVI FOUNTAIN

COUNTRY: Italy  
CITY: Roman

