



# Double-decker electric bus

Can exercise the following abilities of baby

- ★ Processing visual input through some actions. Creativity and imagination help children keep trying new ideas.
- ★ Help them gradually form an innovative thinking and constantly find new ways to solve problems.
- ★ It is conducive to the development of "space wisdom".



6+ / 491PCS / 4974

Suitable  
Age

Parts  
Total

Product  
Number

**INTERCITY  
BUS**

# PARTS LIST



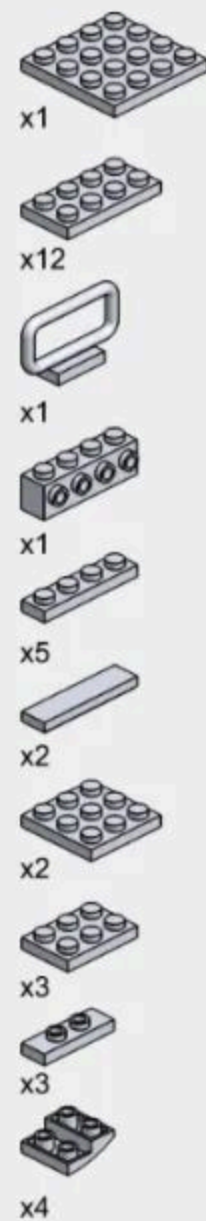
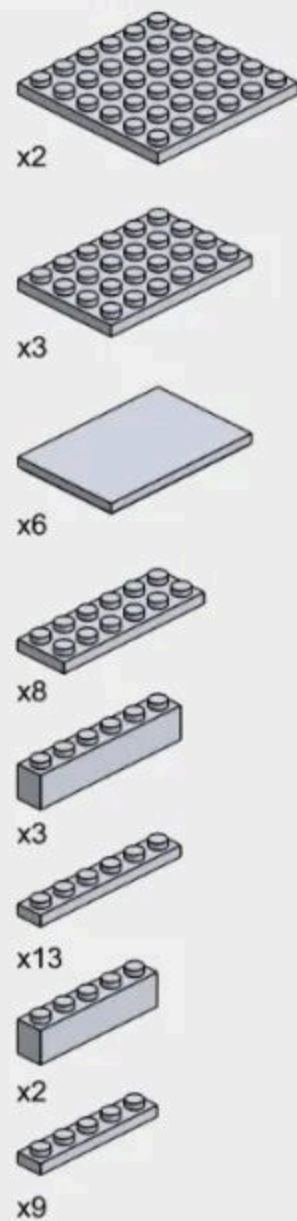
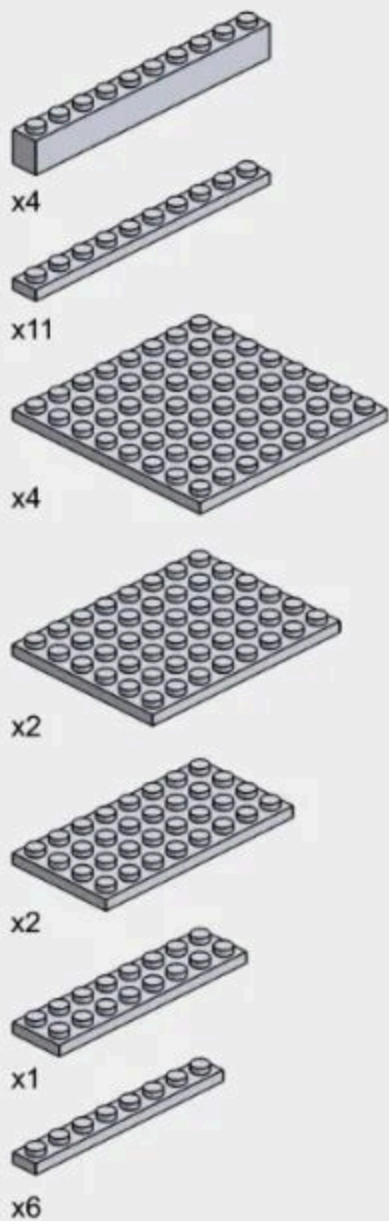
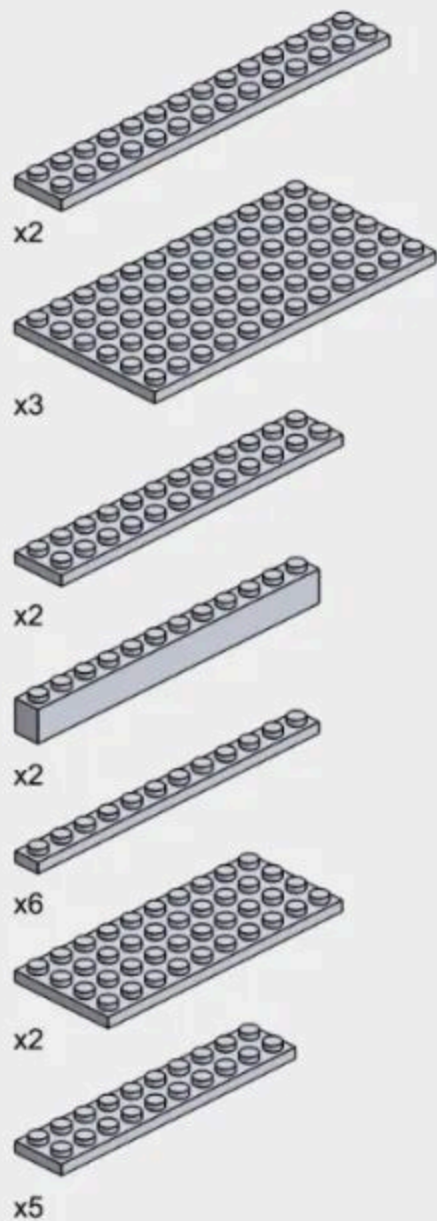











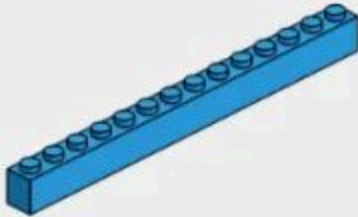





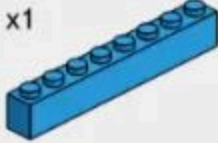





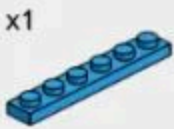



















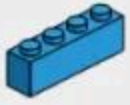





配件清单



产品有增补件请以实物为准  
 If product has additional parts, please in kind prevail.

# PARTS LIST

配件清单

- |   |   |  |   |   |   |   |
|---|---|--|---|---|---|---|
| <br>x1   | <br>x2   | <br>x3    | <br>x1  | <br>x1   | <br>x2   | <br>x2   |
| <br>x3   | <br>x6   | <br>x1    | <br>x5  | <br>x1   | <br>x2   | <br>x4   |
| <br>x5   | <br>x3   | <br>x1    | <br>x2  | <br>x1   | <br>x2   | <br>x1   |
| <br>x3   | <br>x2   | <br>x4    | <br>x2  | <br>x1   | <br>x1   | <br>x2   |
| <br>x2   | <br>x2   | <br>x1    | <br>x2   | <br>x6   | <br>x1   | <br>x2   |
| <br>x2  | <br>x2  | <br>x2   | <br>x2   | <br>x3  | <br>x2   | <br>x1   |
| <br>x6 | <br>x1 | <br>x31 | <br>x4 | <br>x2 | <br>x2 | <br>x2   |
| <br>x2 | <br>x6 | <br>x2  | <br>x2 | <br>x1 | <br>x1 | <br>x33 |

产品有增补件请以实物为准  
If product has additional parts, please in kind prevail.



244PCS

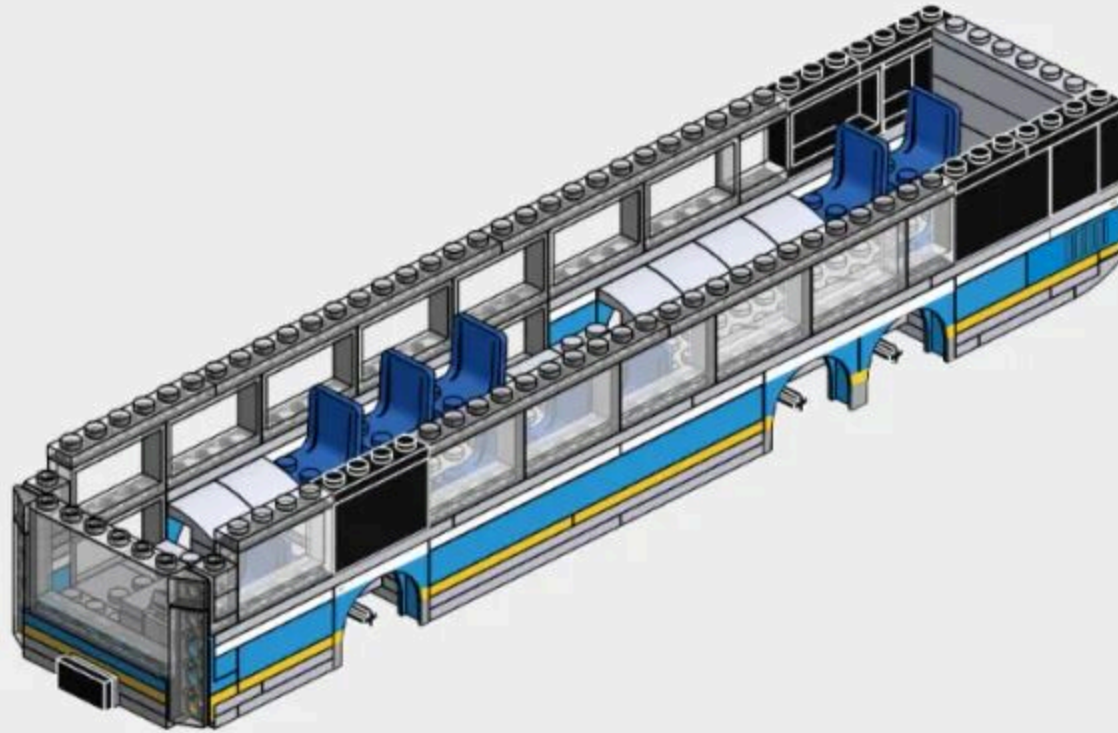

# 1-1

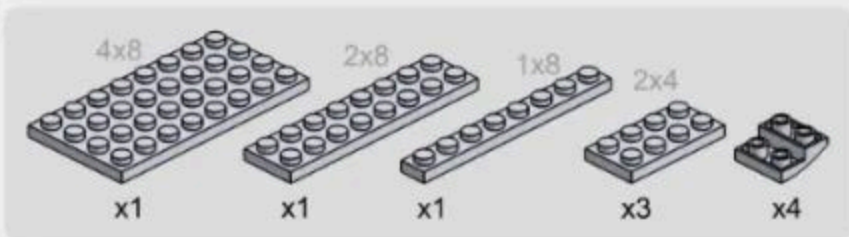

# 1-2

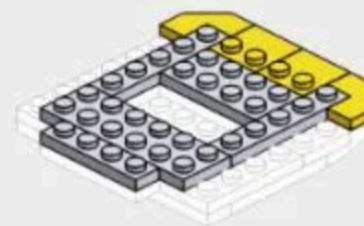
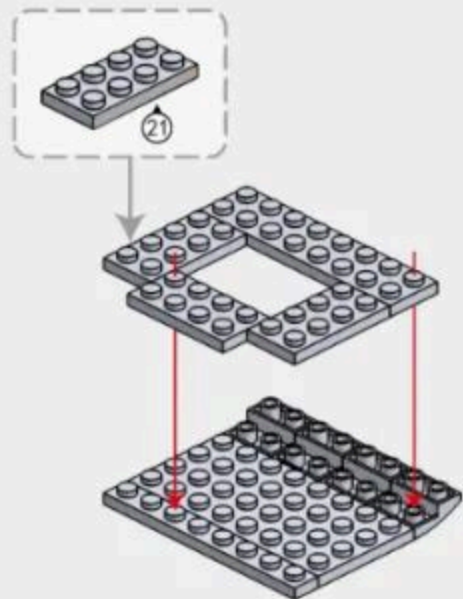
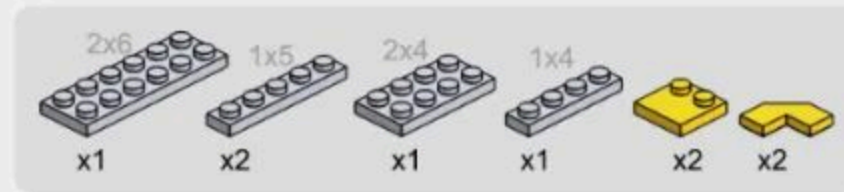

1-3

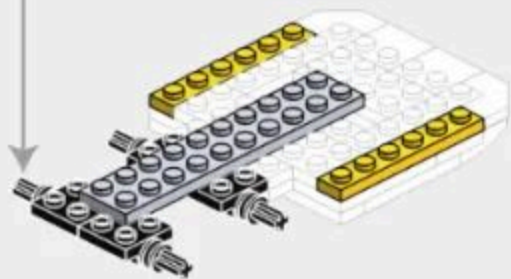
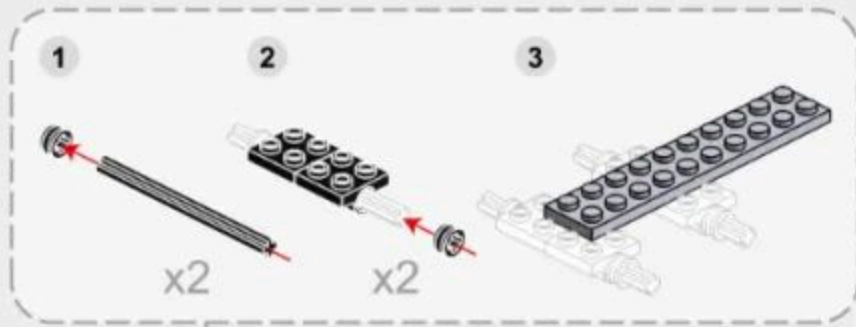
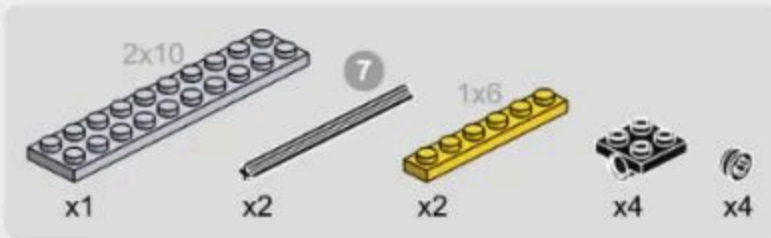

1-4

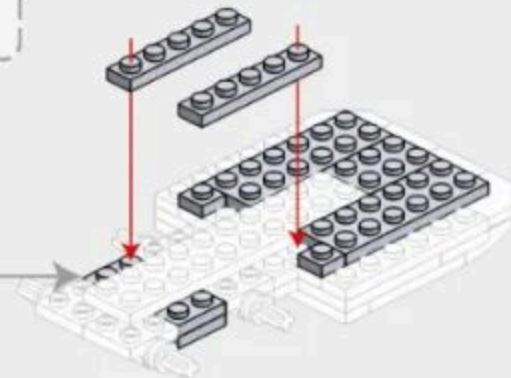
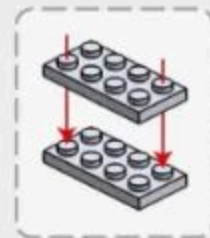
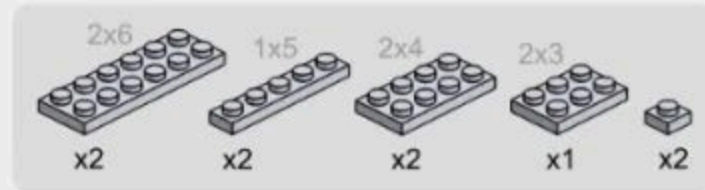

1-5

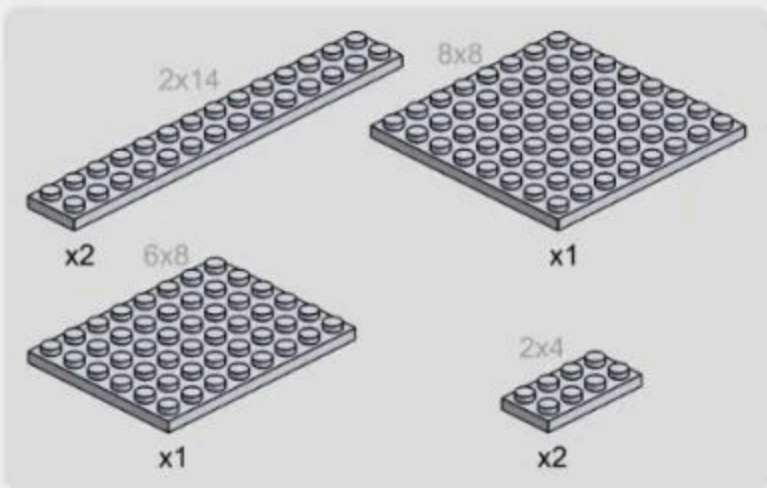

1-6

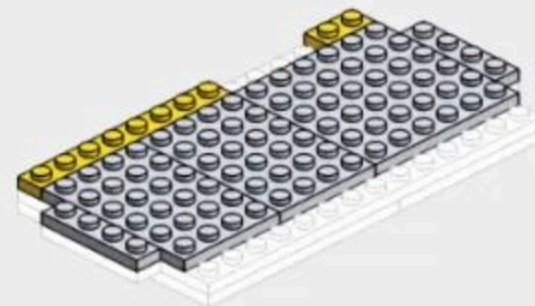
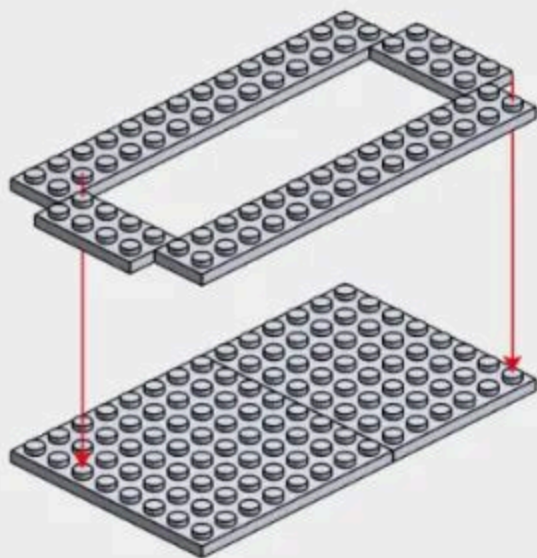
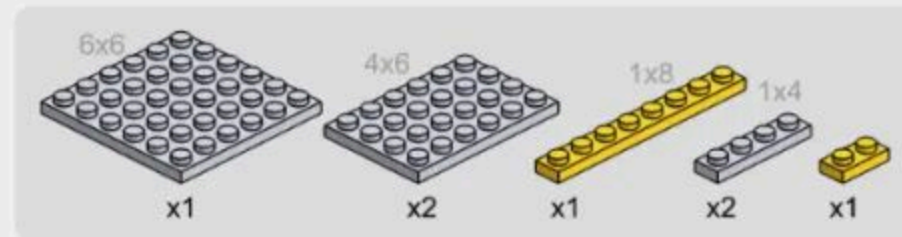

1-7

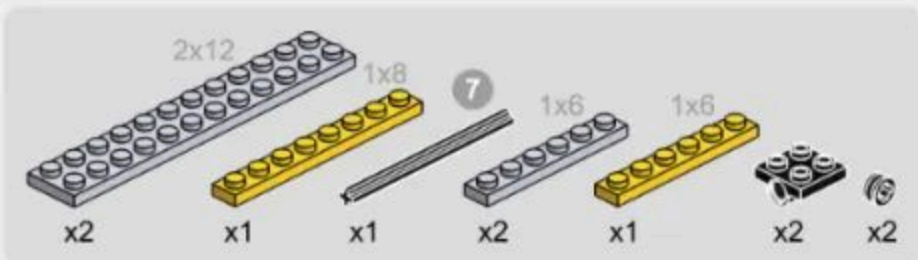

1-8

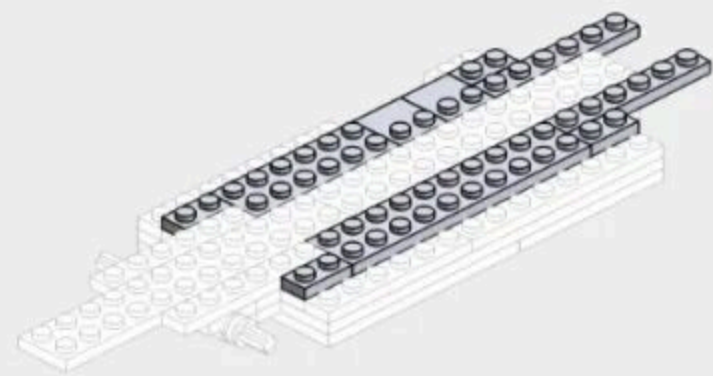
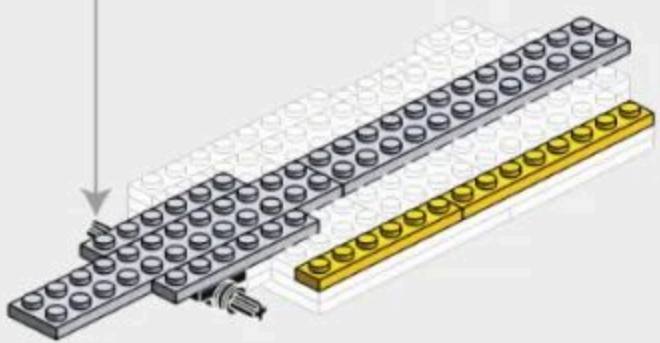
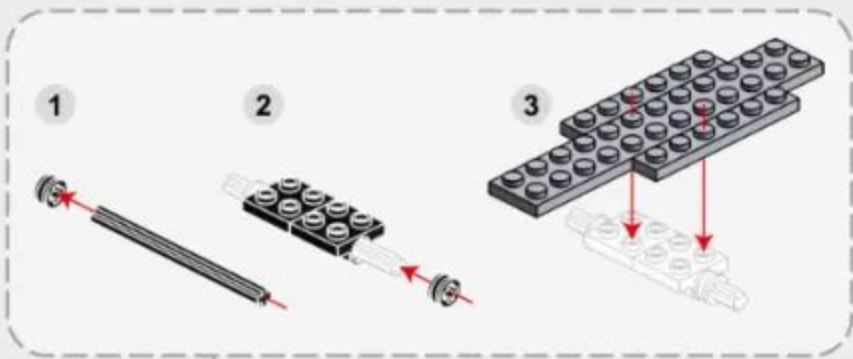
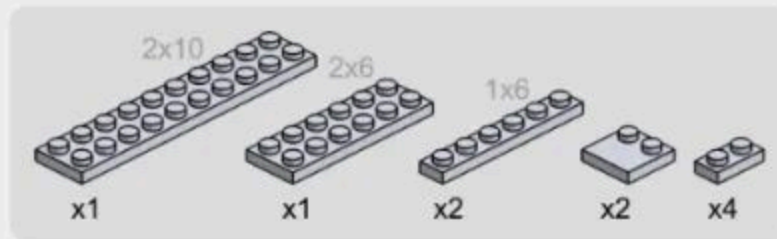

1-9

1-10

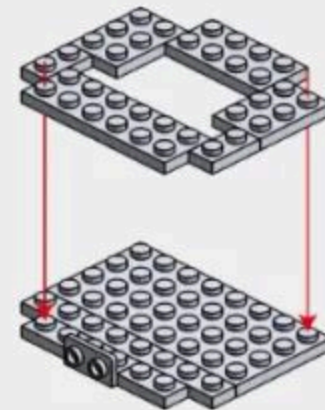
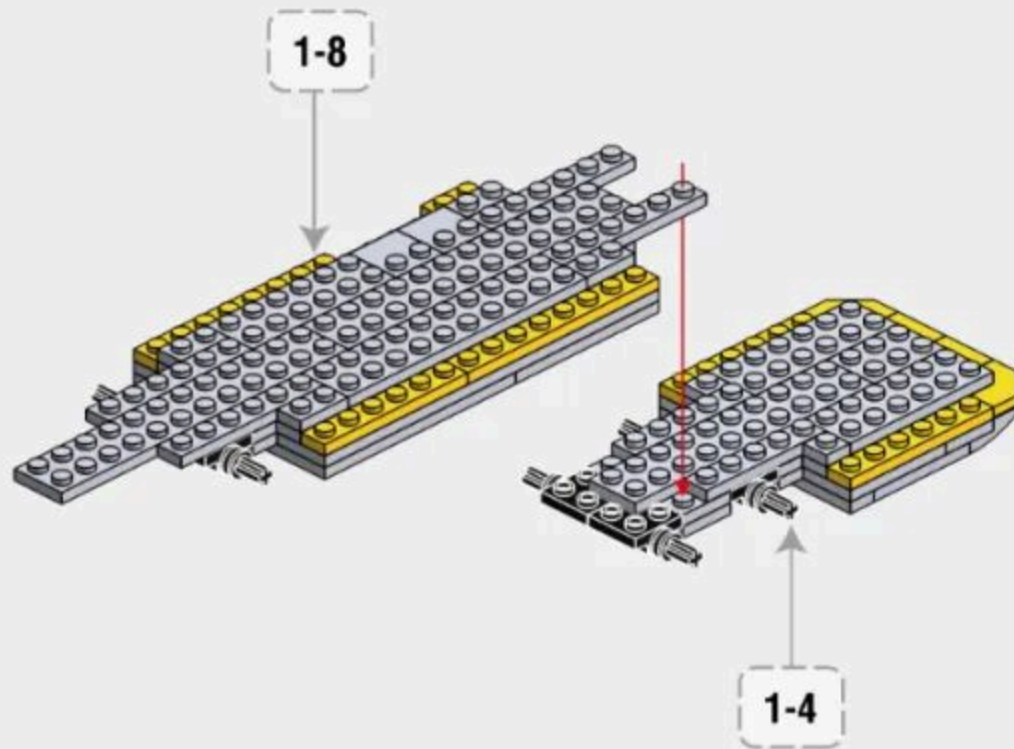
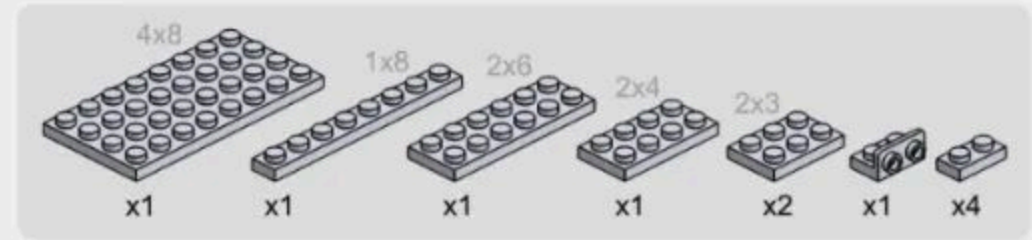

### 1-11

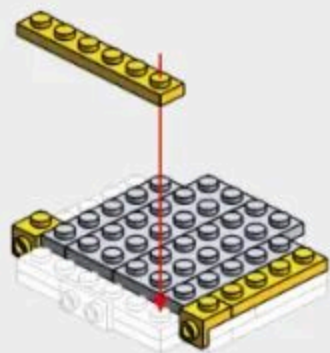
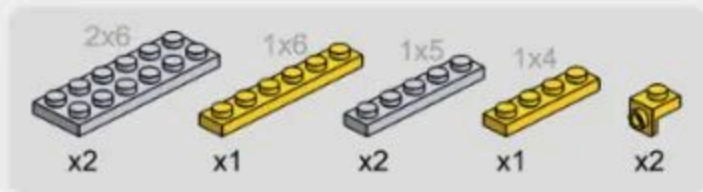

### 1-12

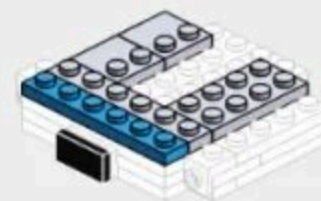
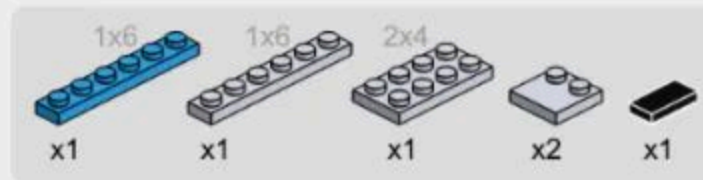

1-13

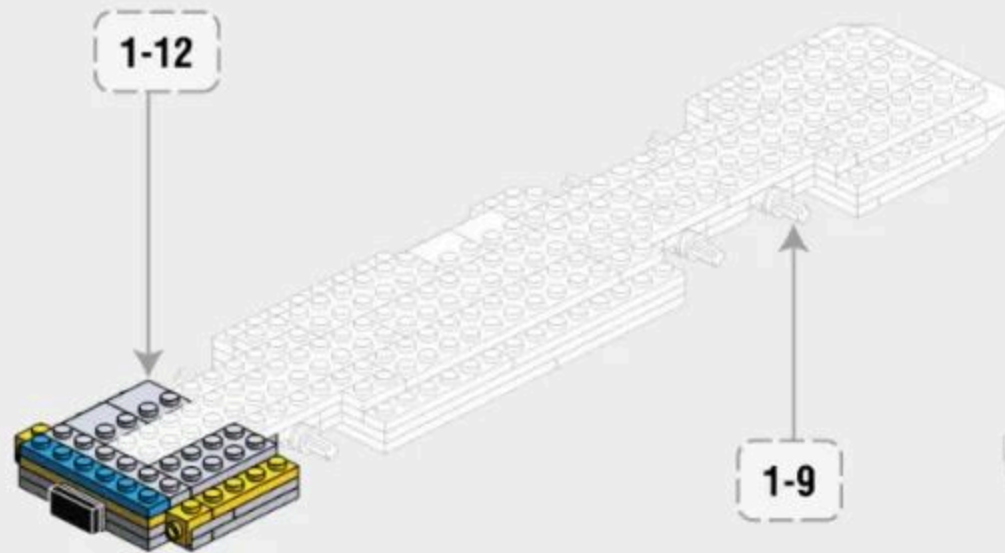

1-14

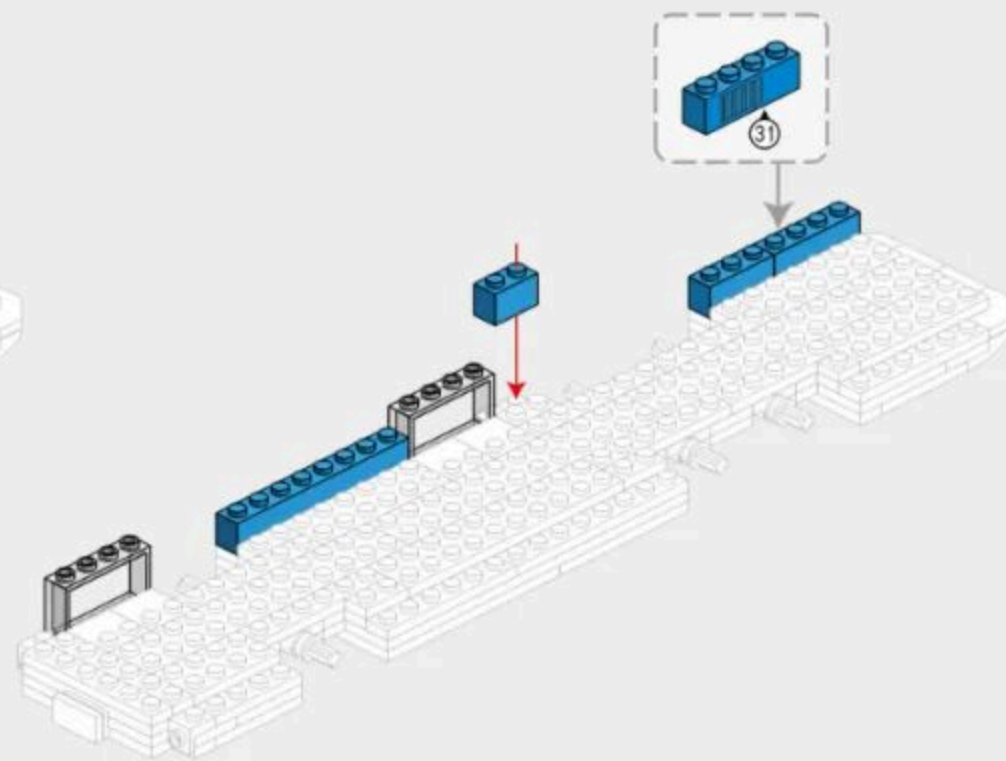
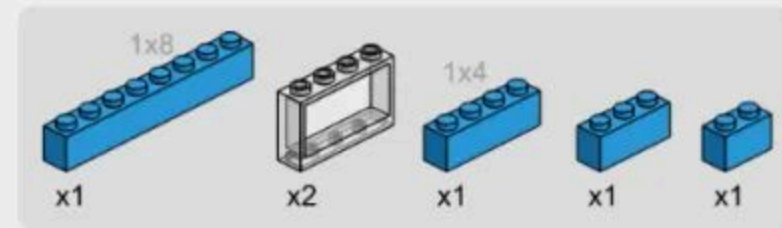

1-15

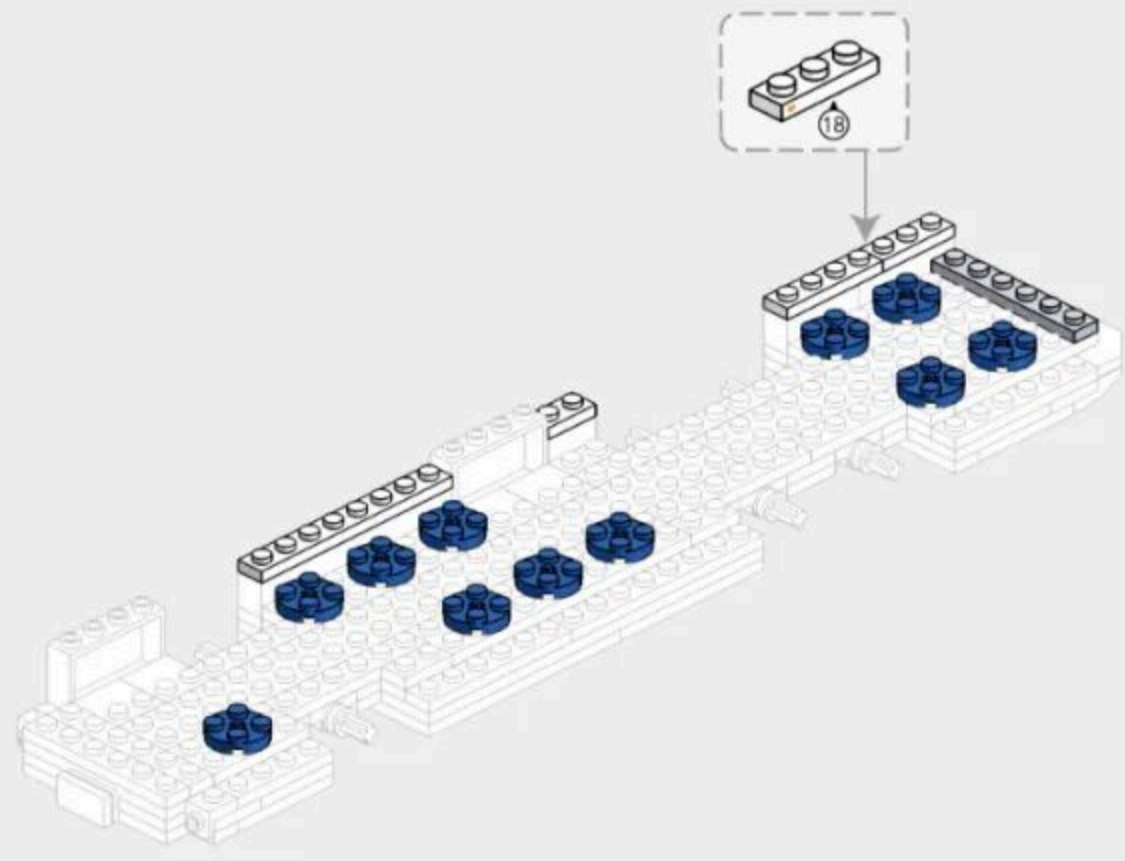
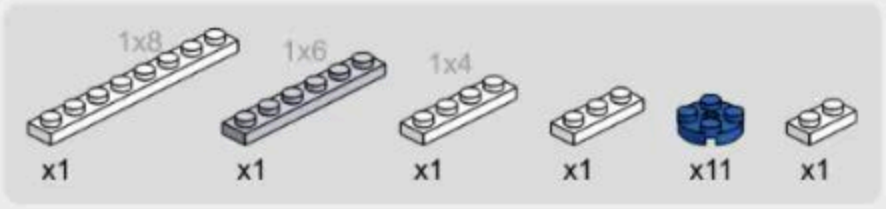

1-16

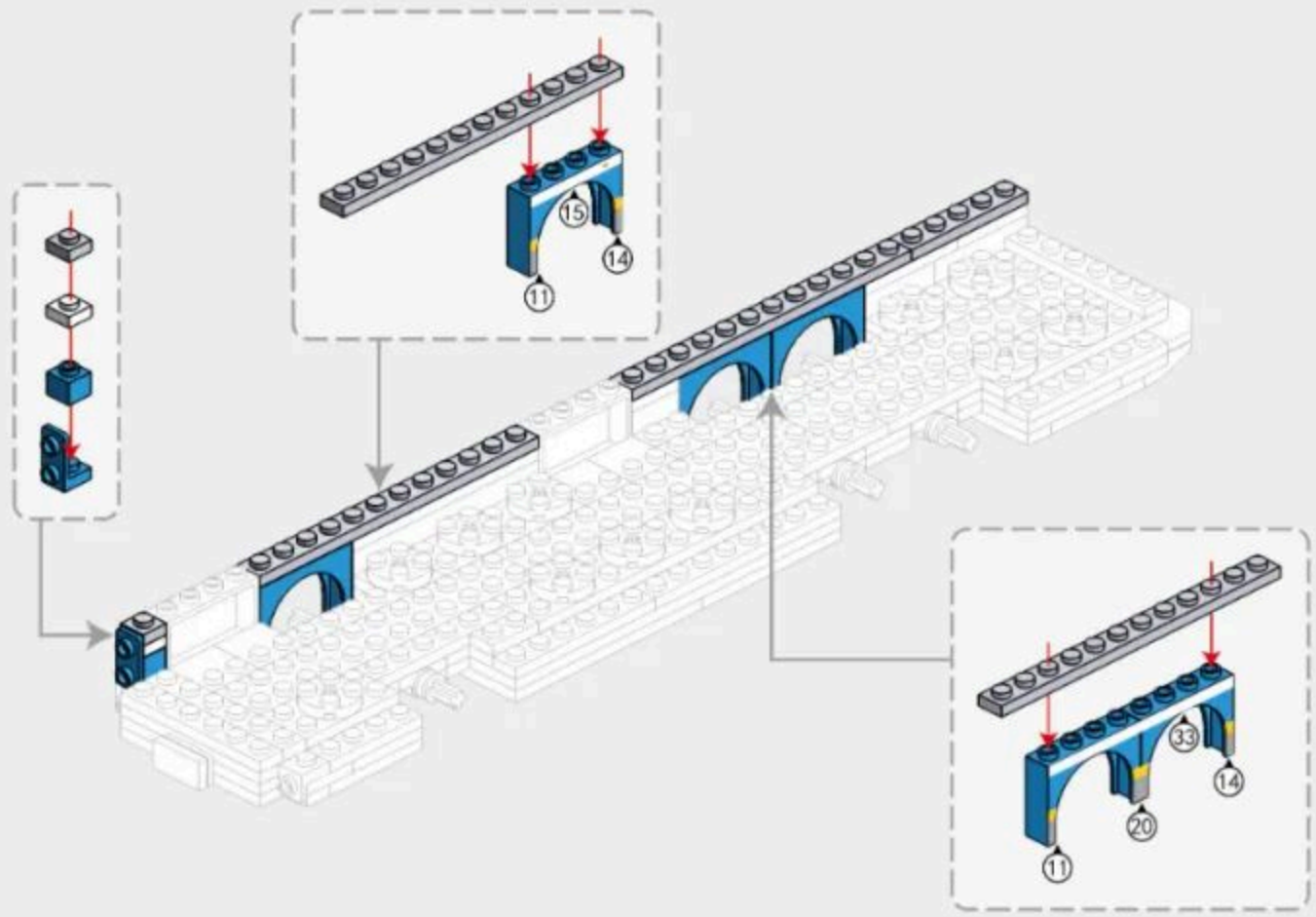
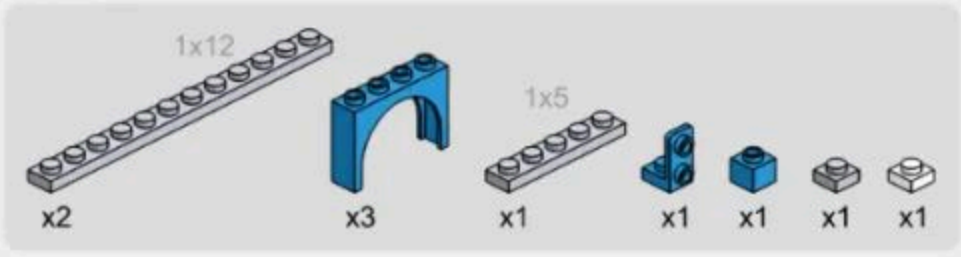

1-17

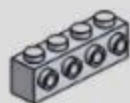

x1



x1



x2



x1



x1



x1



x1

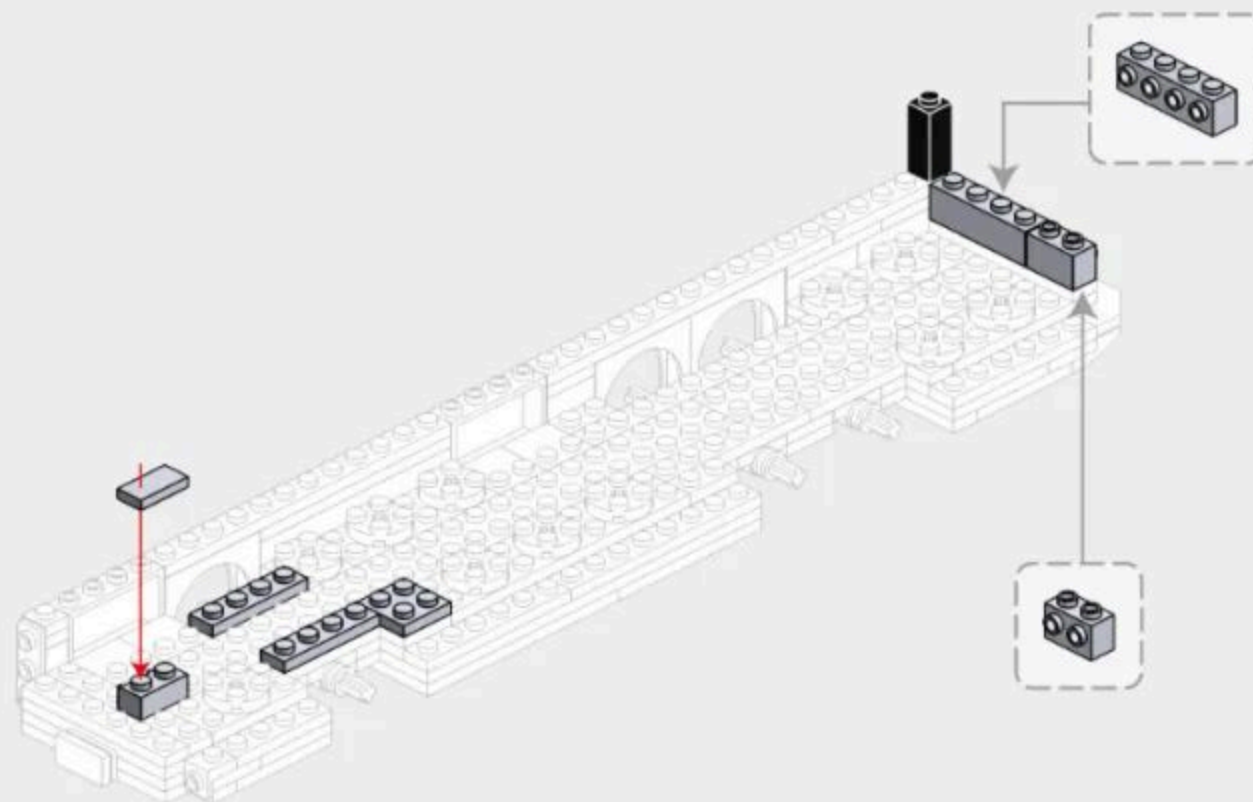

1-18

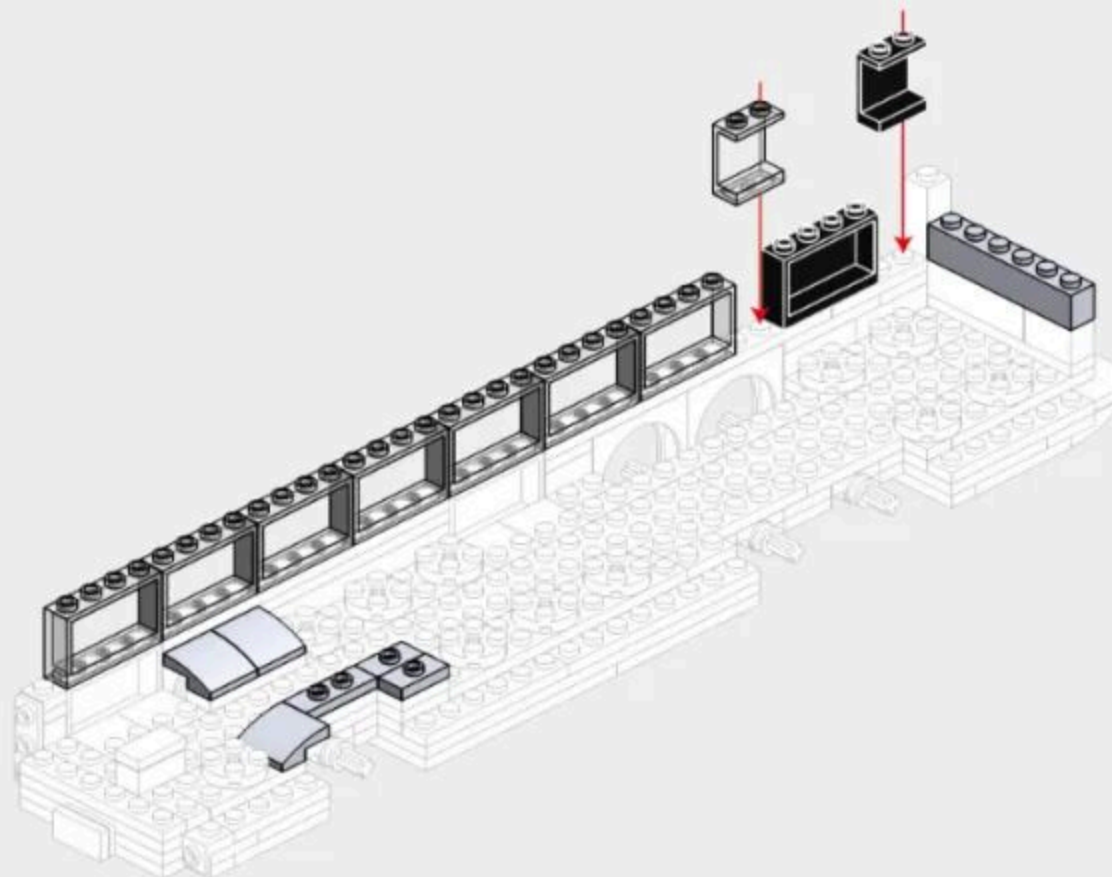
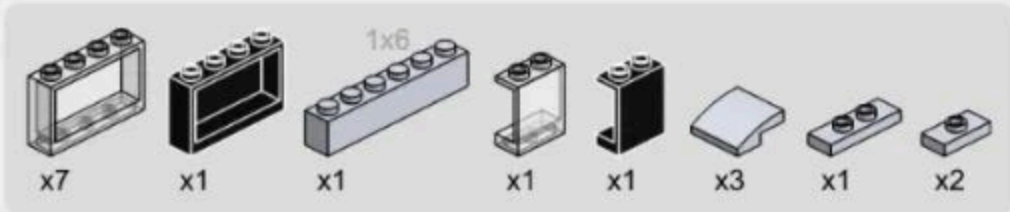

# 1-19

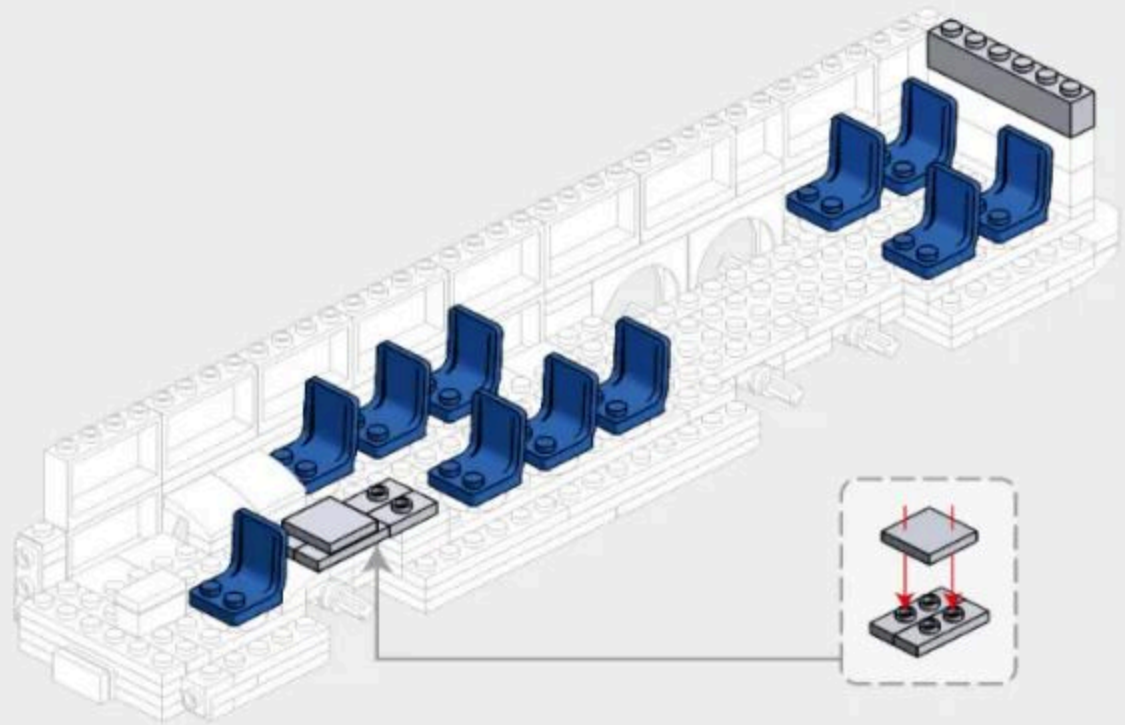
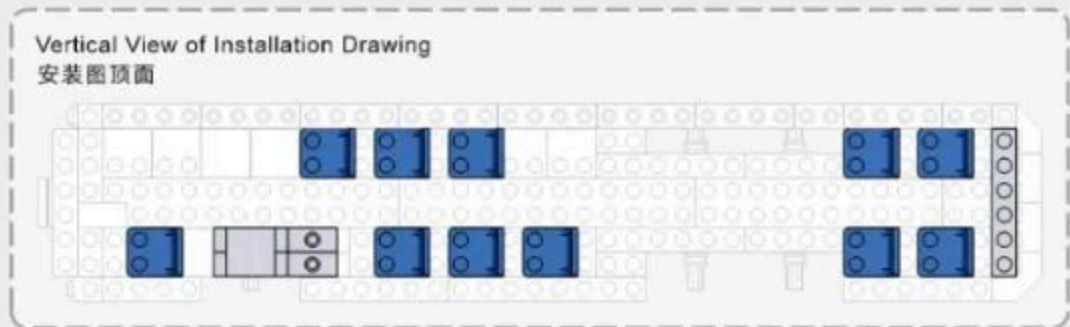
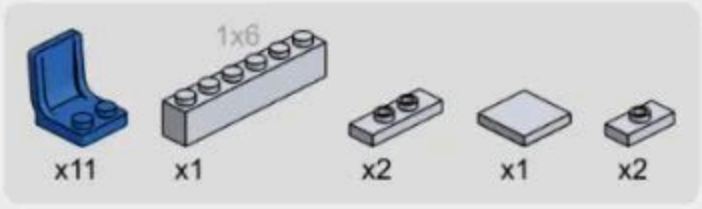





1-22

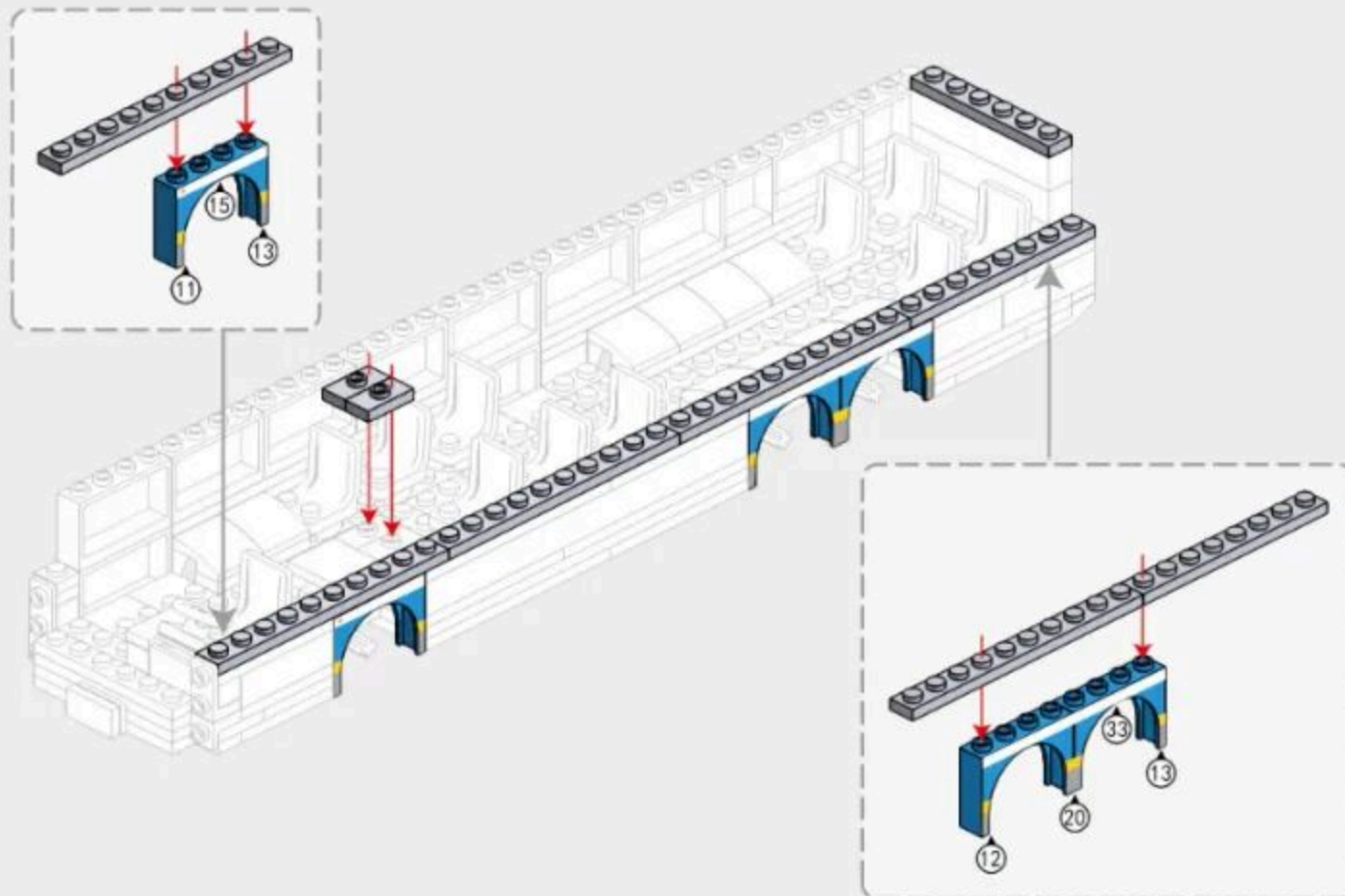
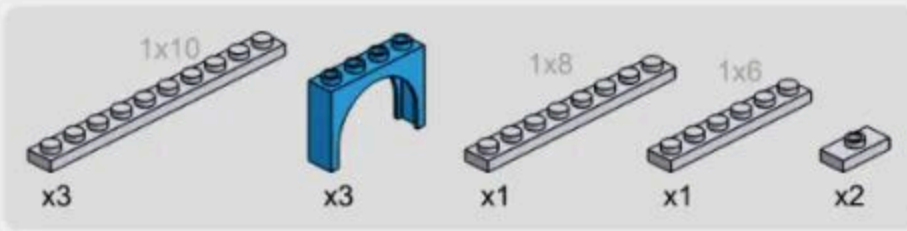

1-23



x6



x2



x1



x1



x1

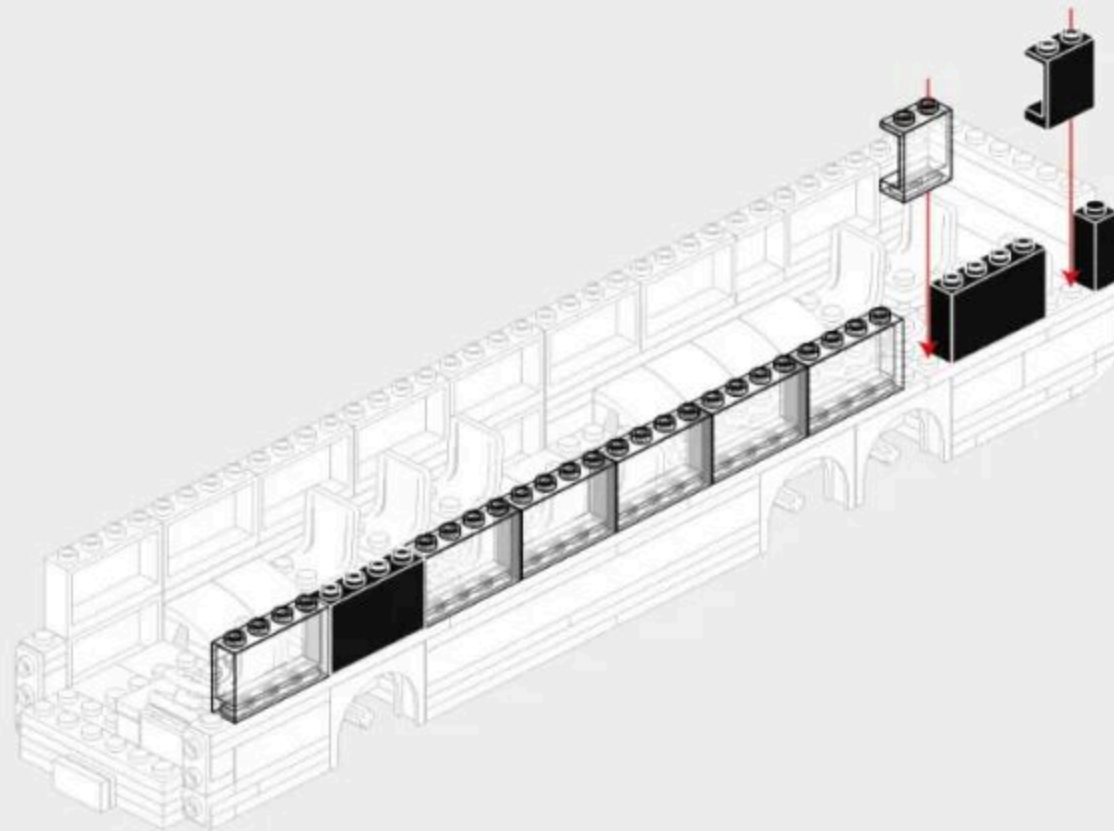

1-24

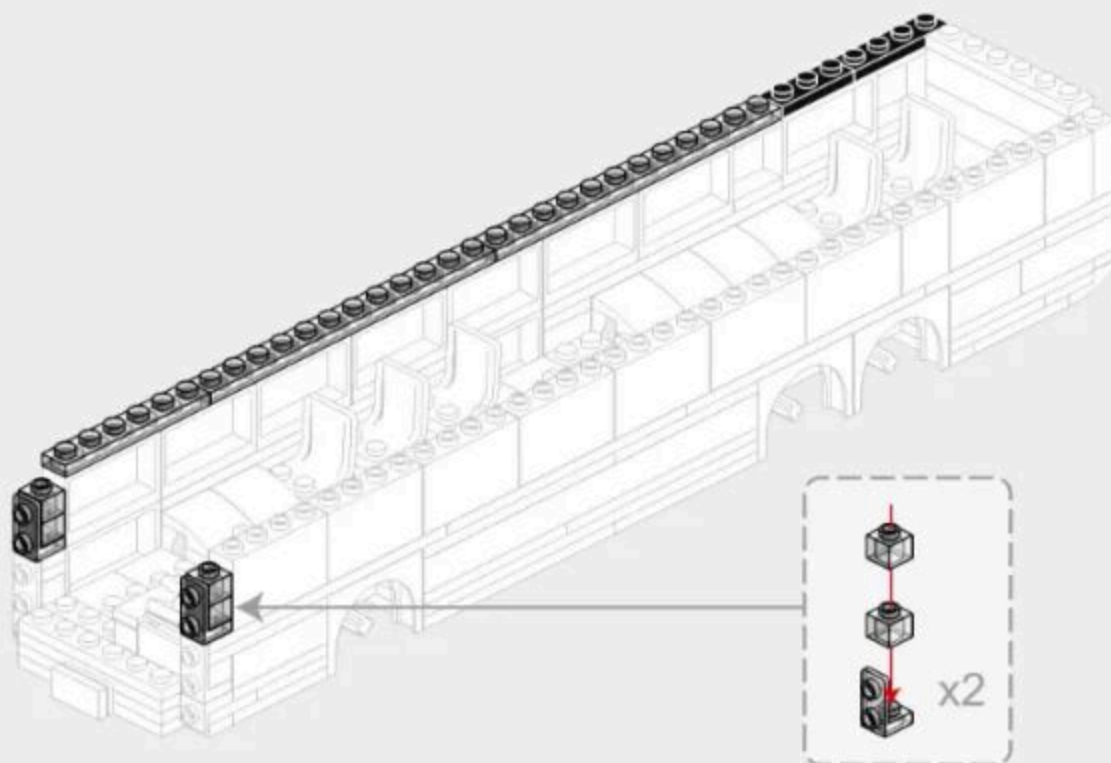
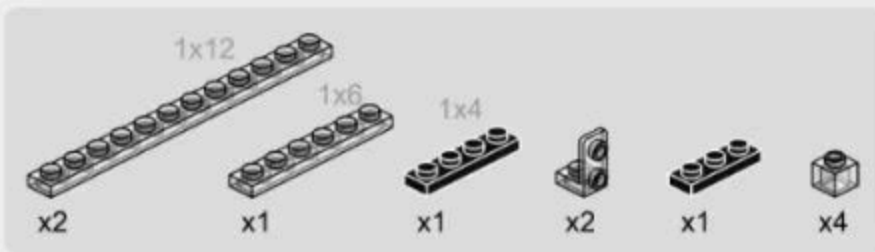

1-25

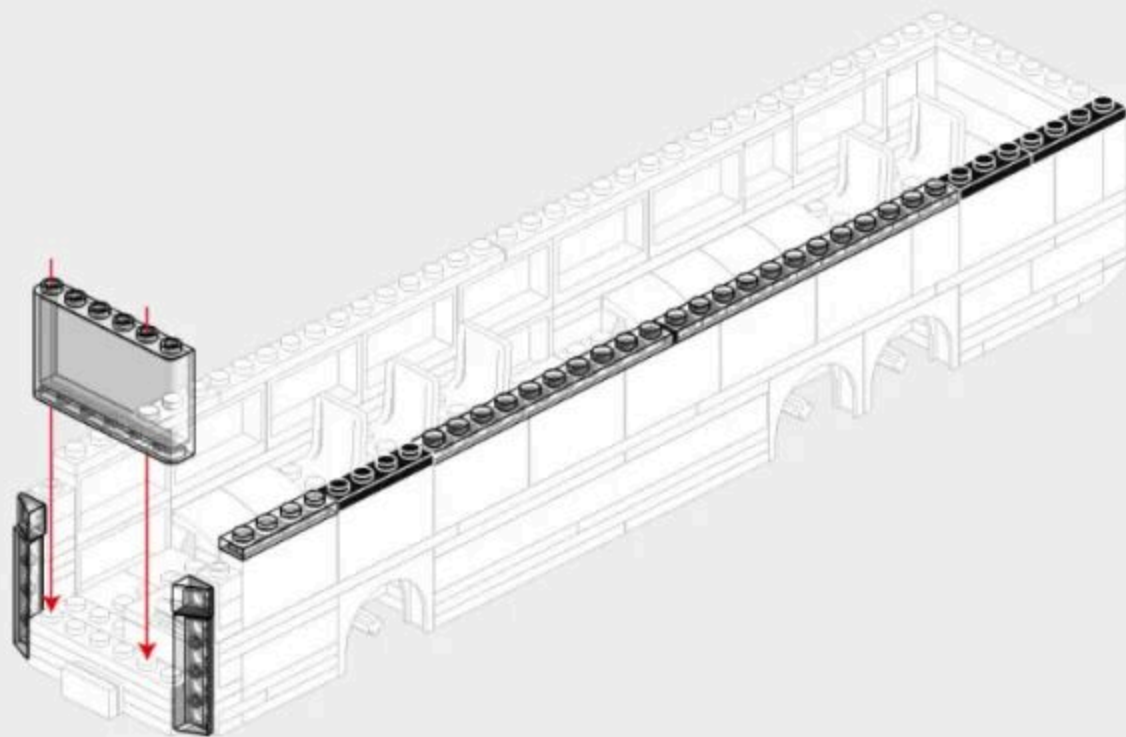
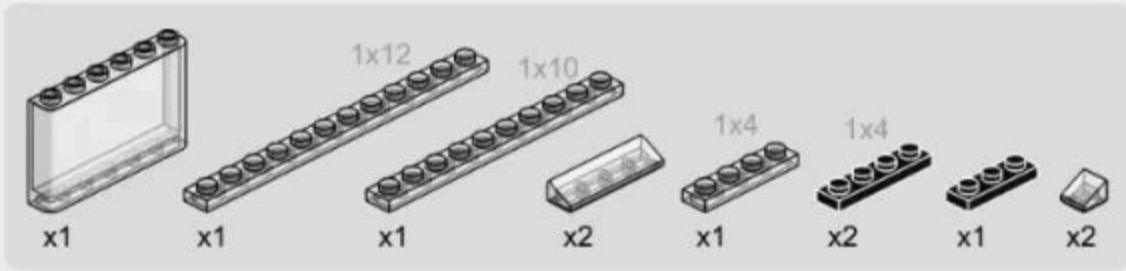



247PCS



2-1

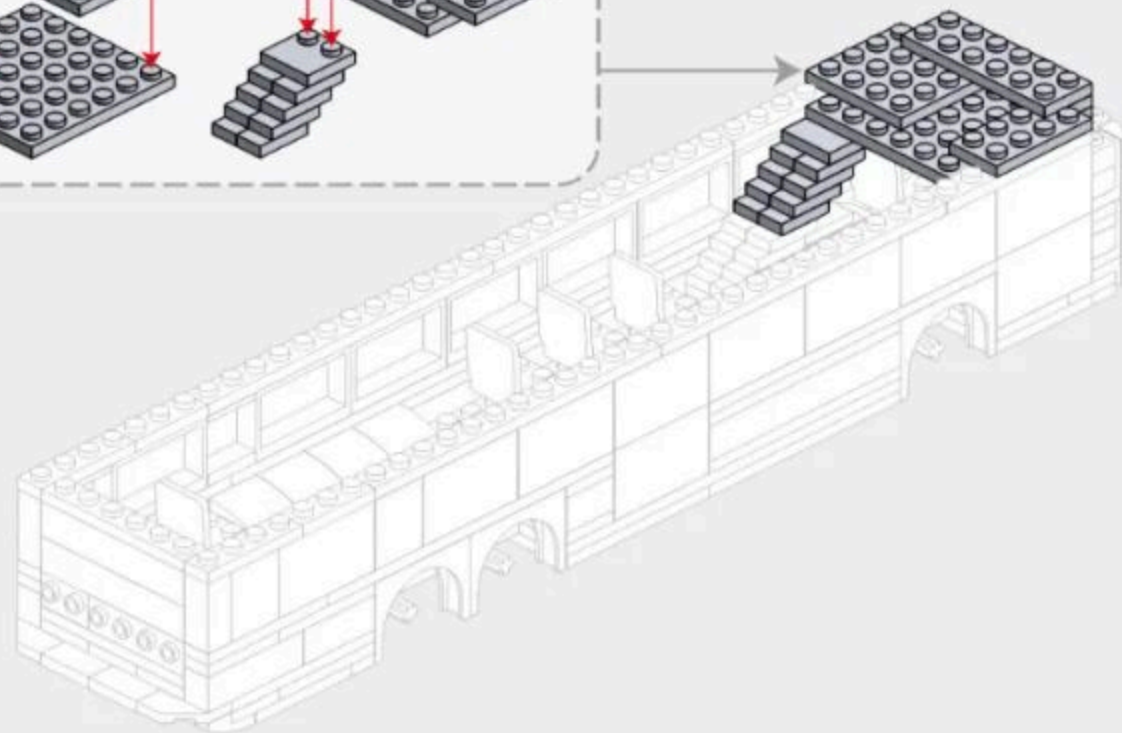
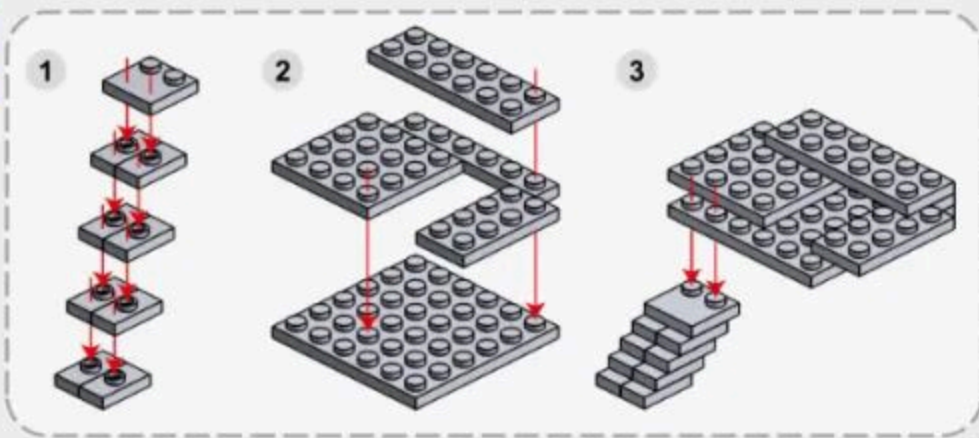
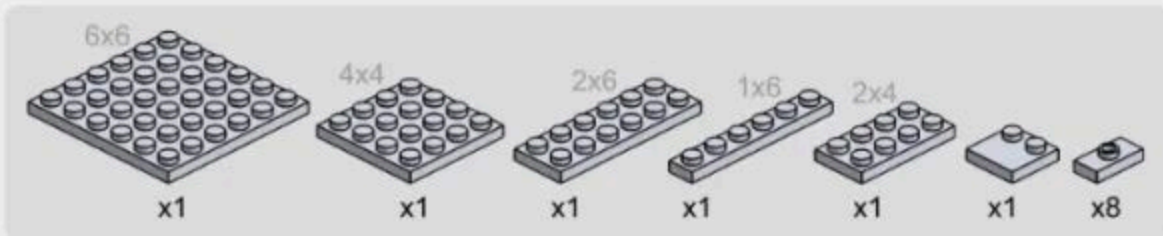

2-2

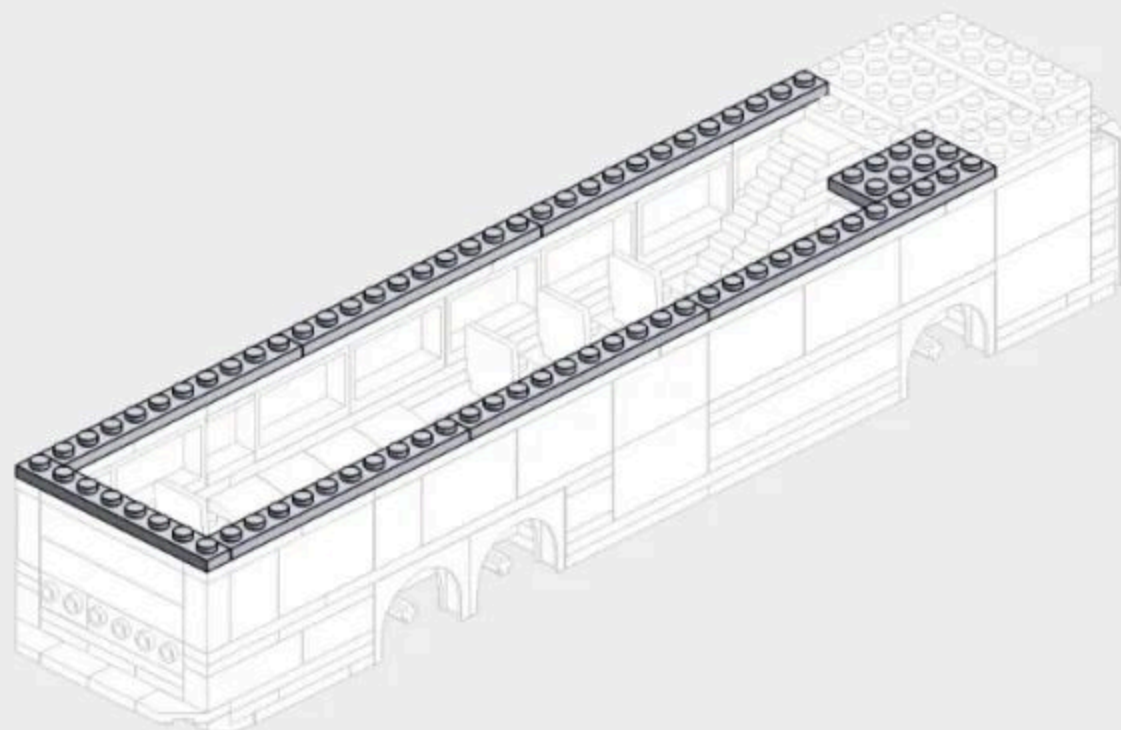
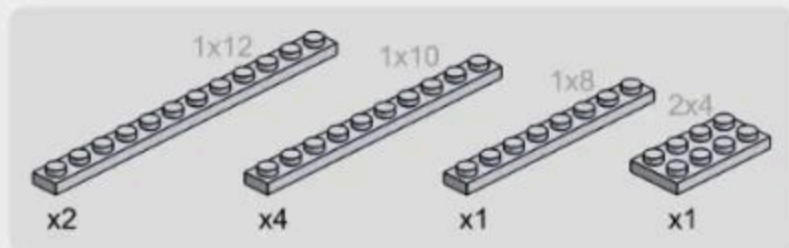

2-3

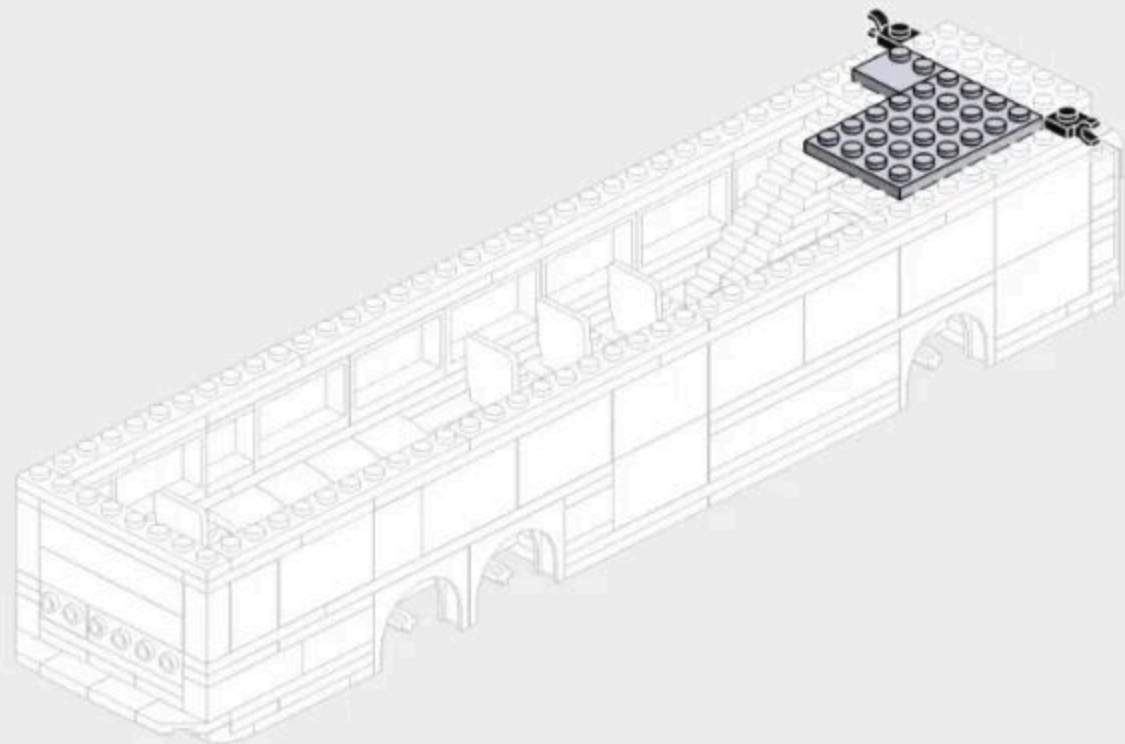
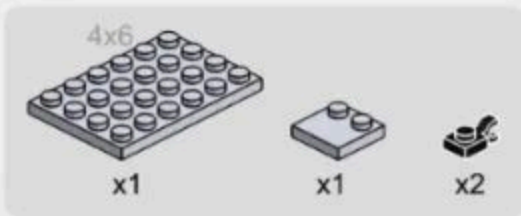

2-4

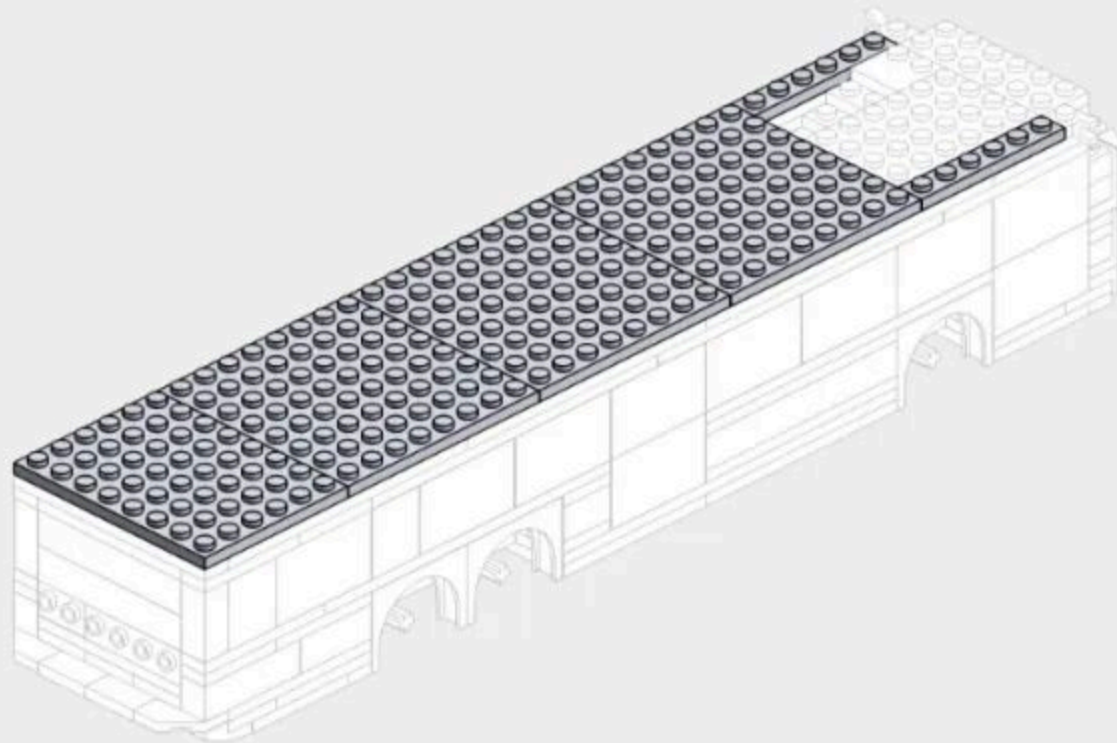
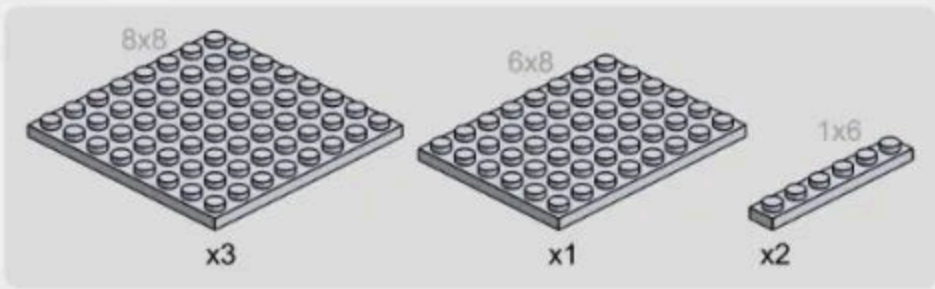

2-5

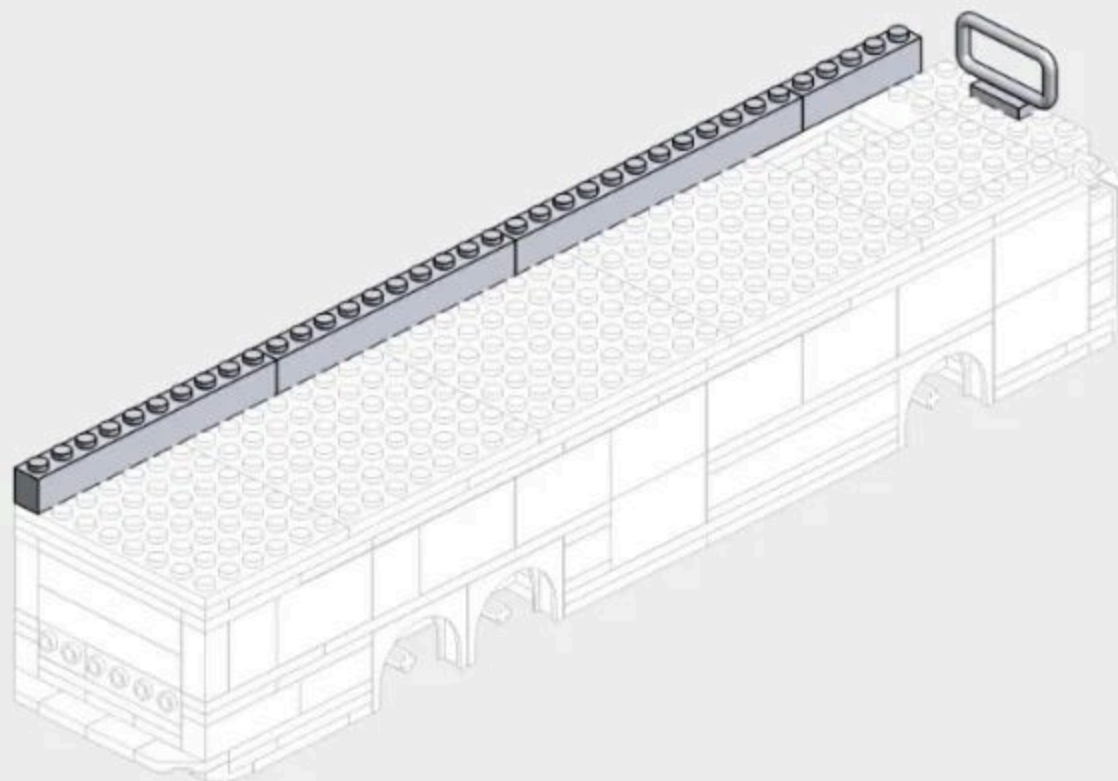
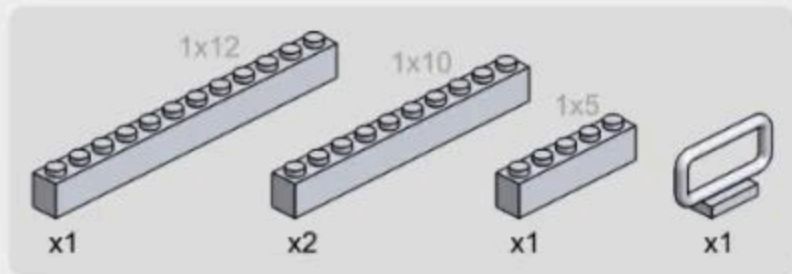

2-6

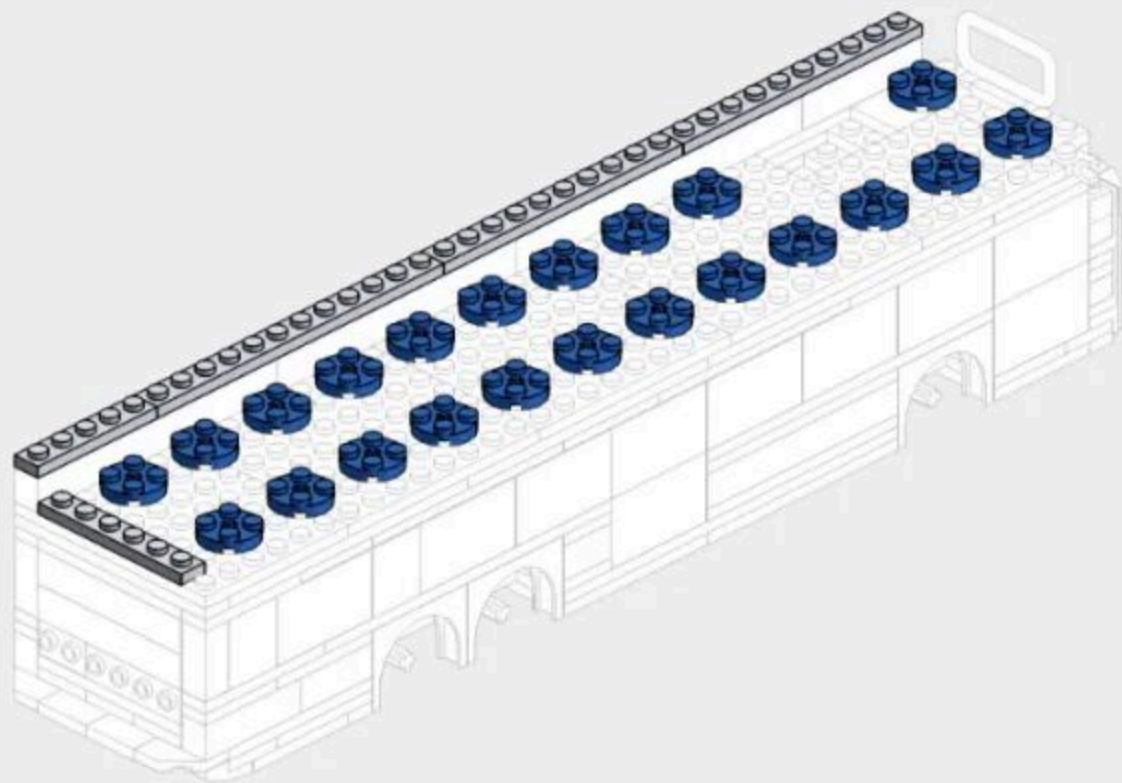
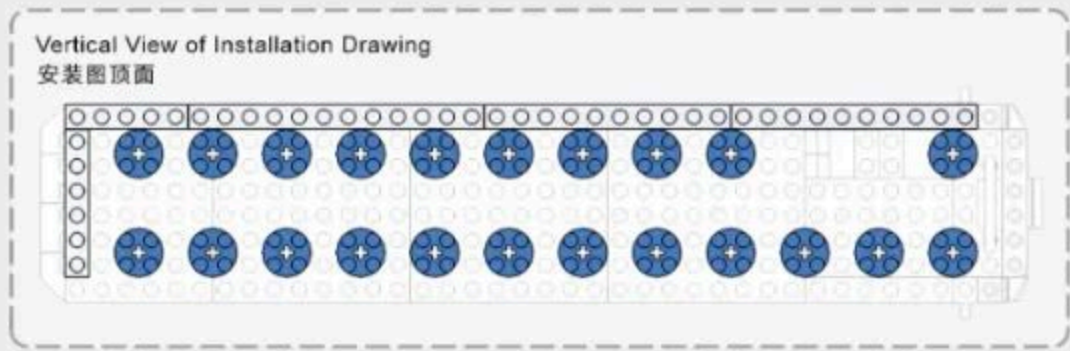
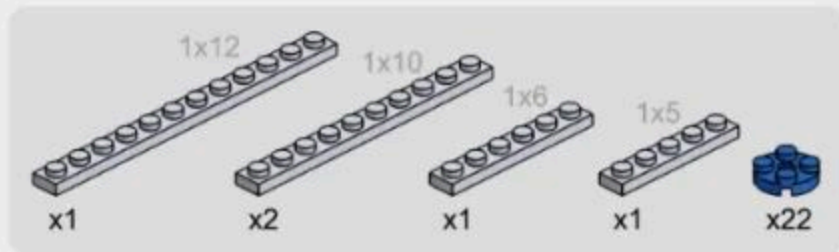

2-7

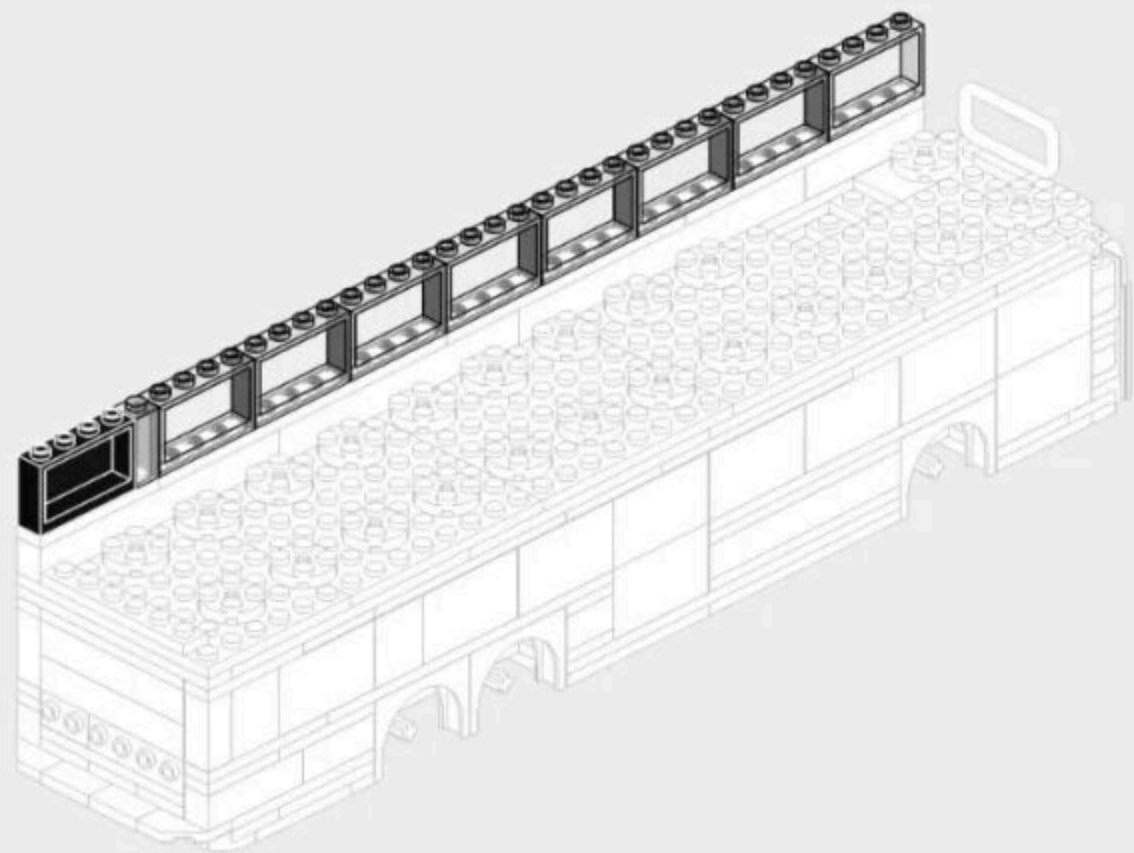
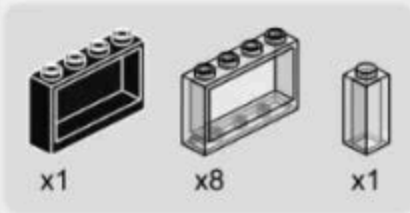

2-8



Vertical View of Installation Drawing  
安装图顶面

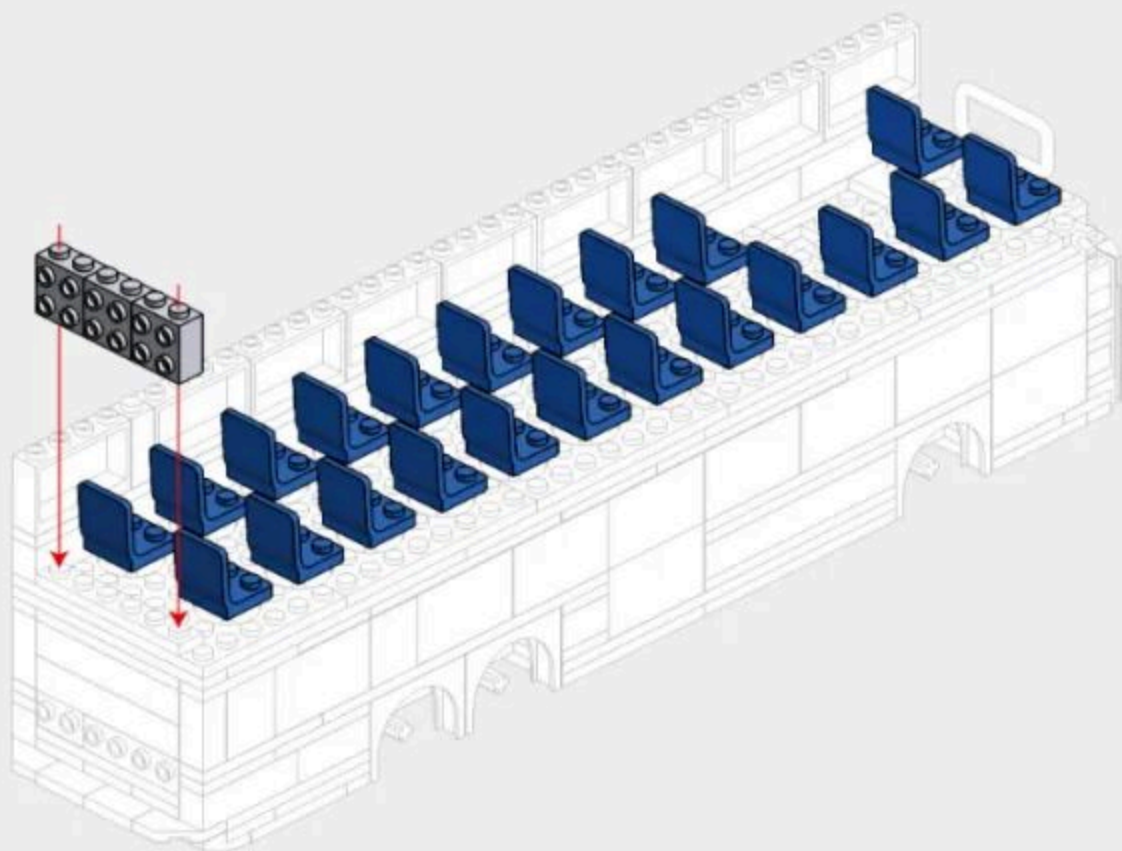
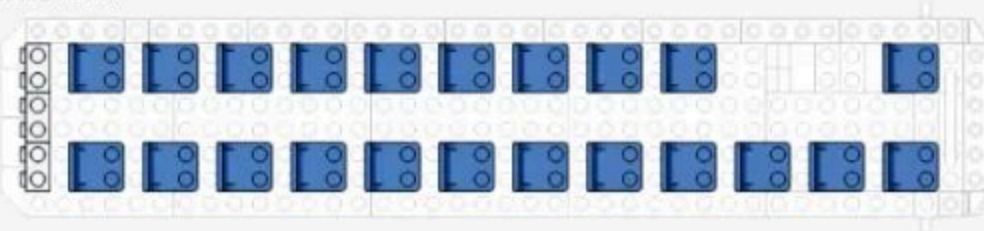

2-9

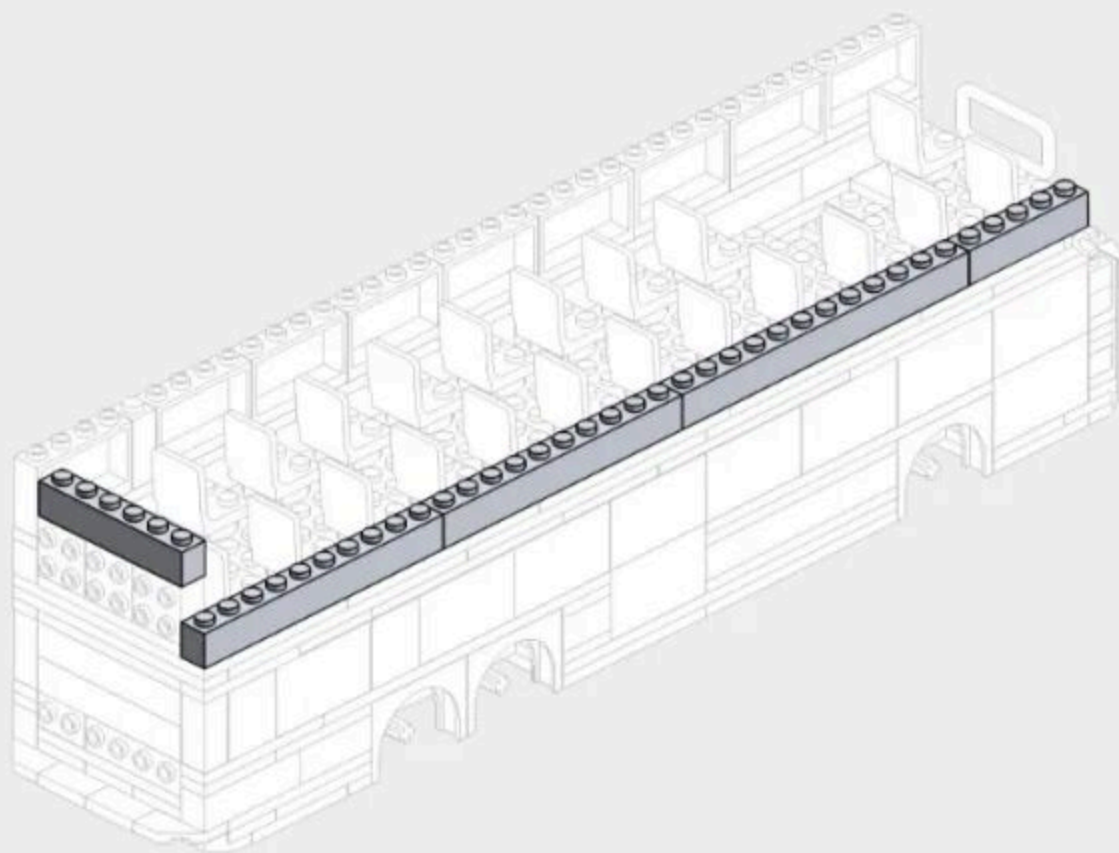
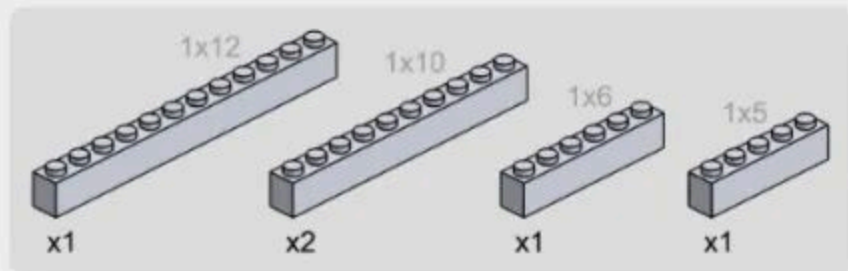

2-10

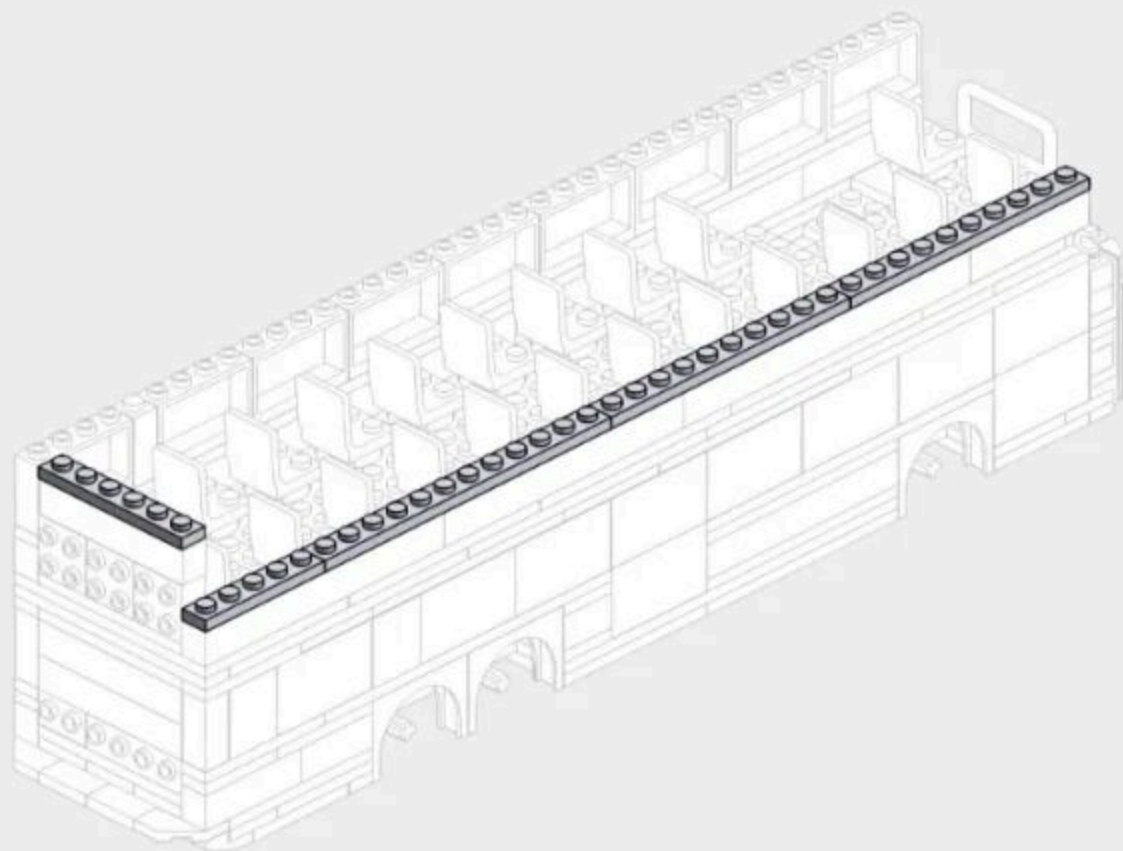
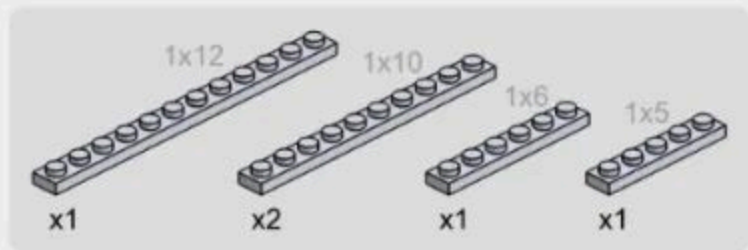

2-11

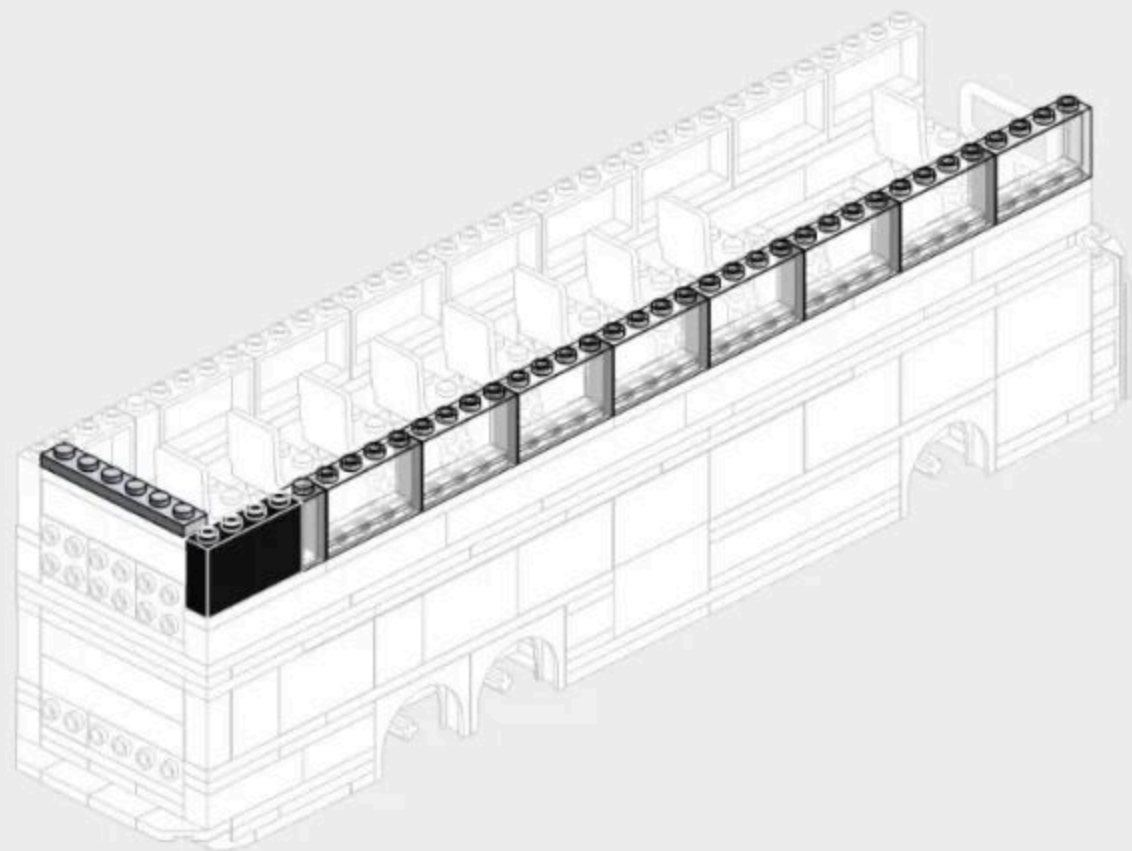
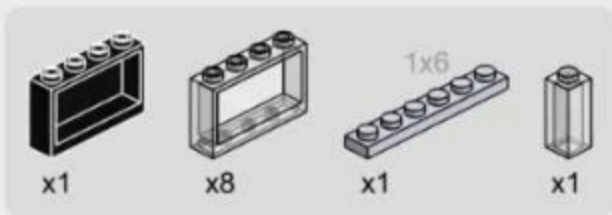

2-12

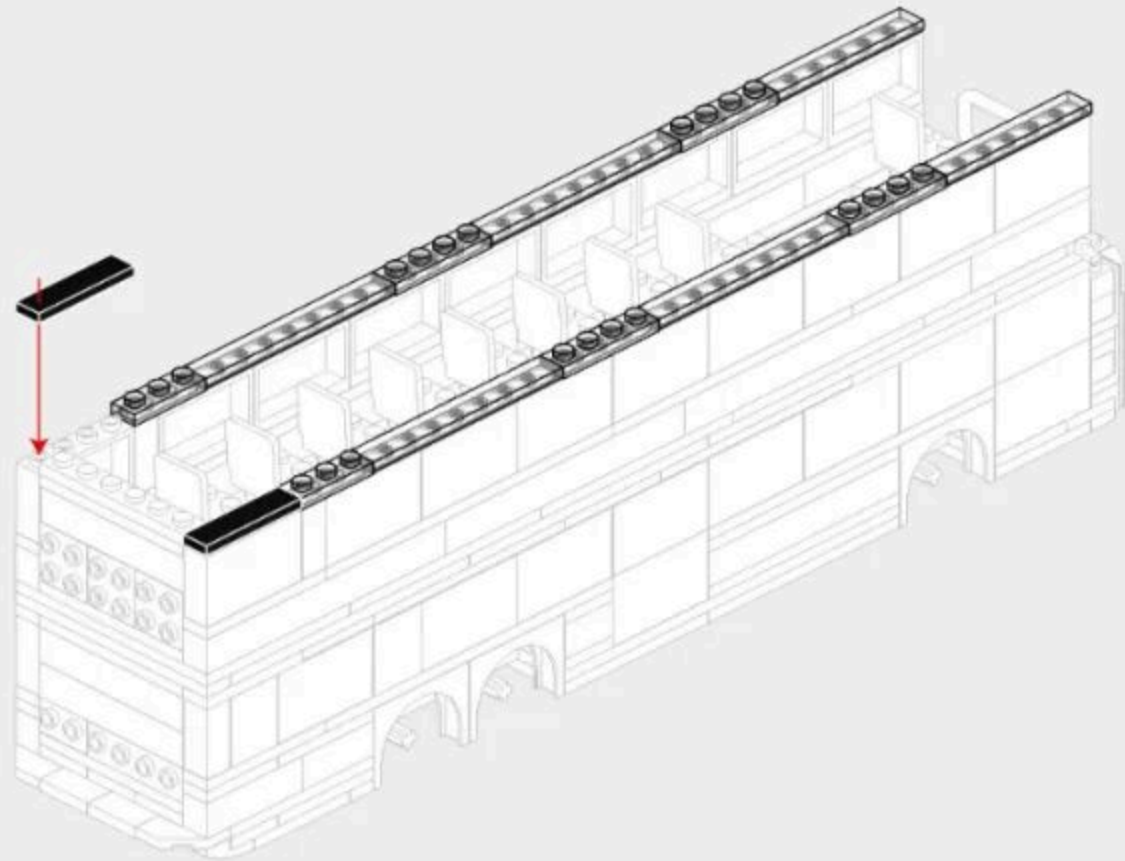
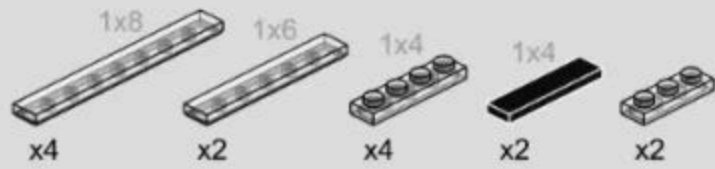



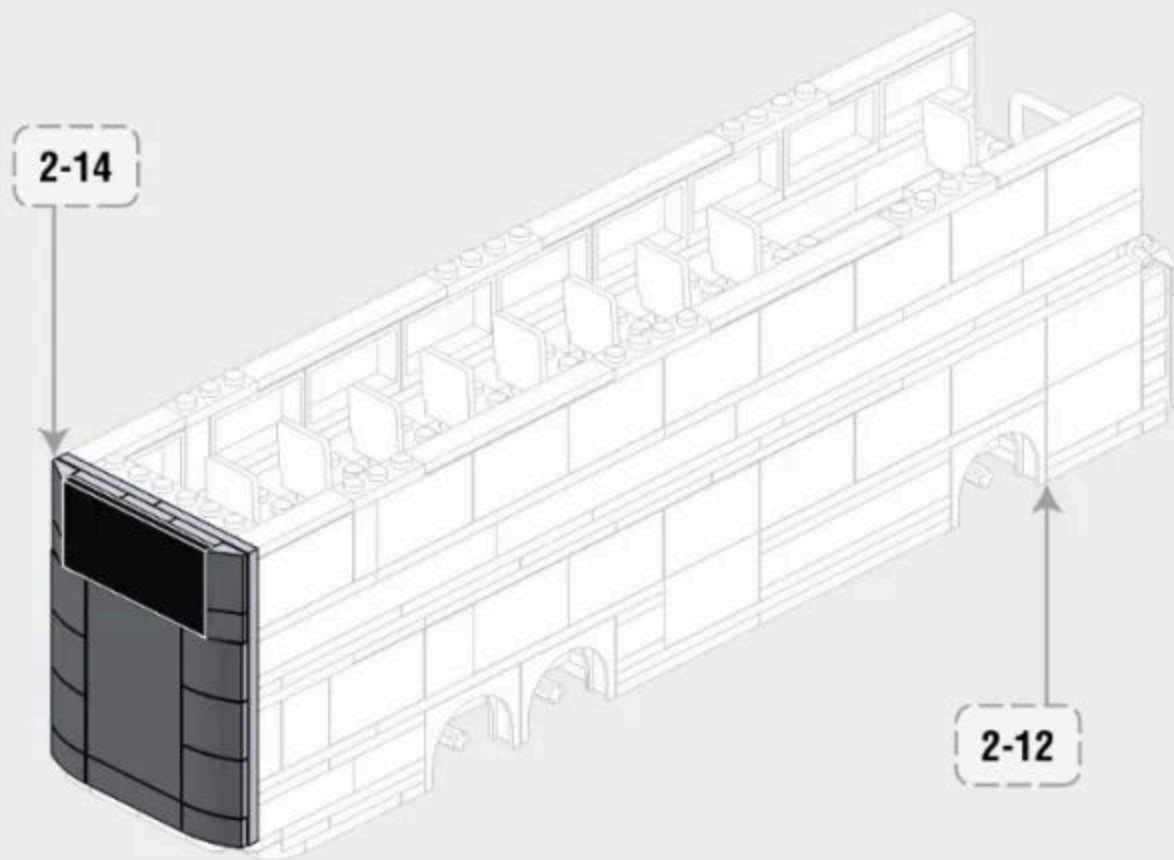

2-16

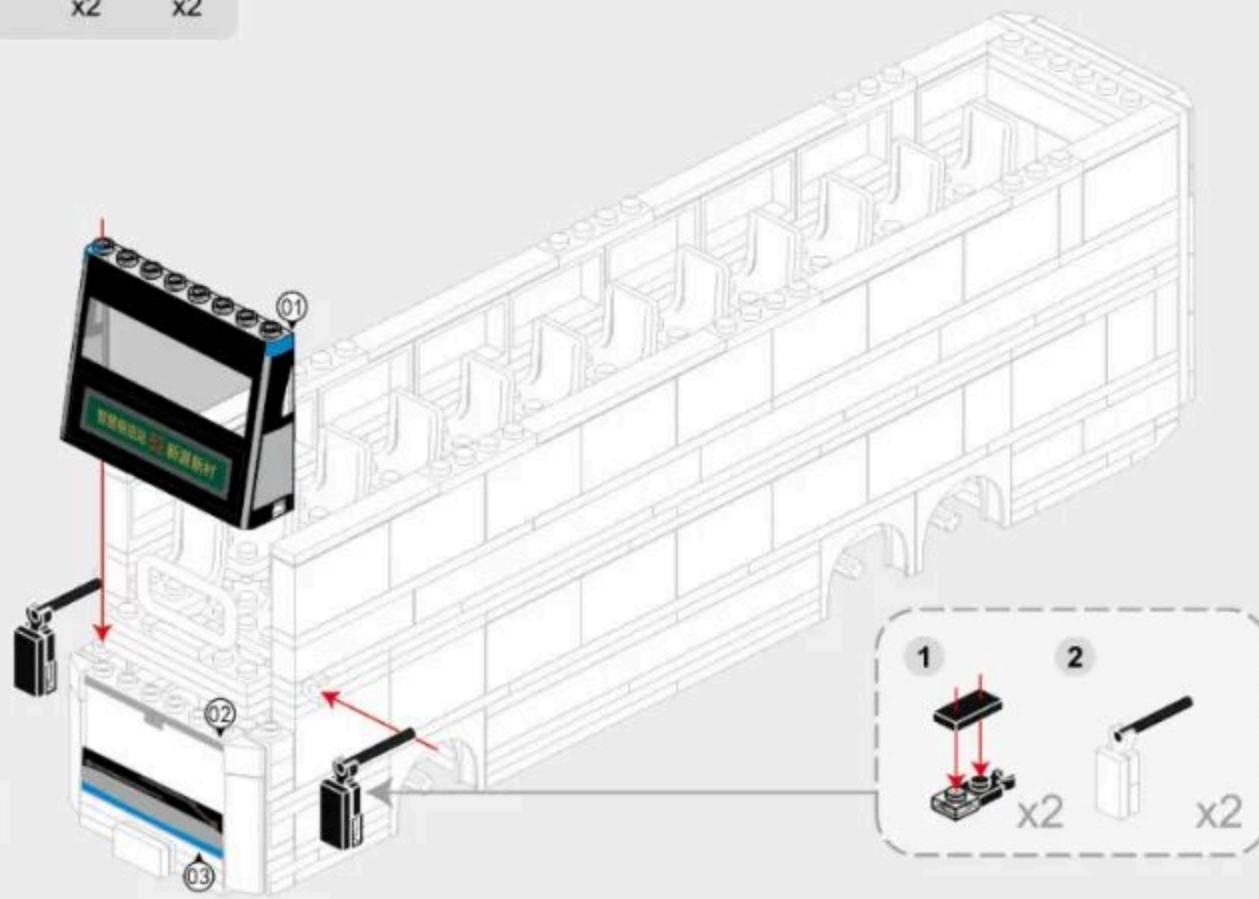
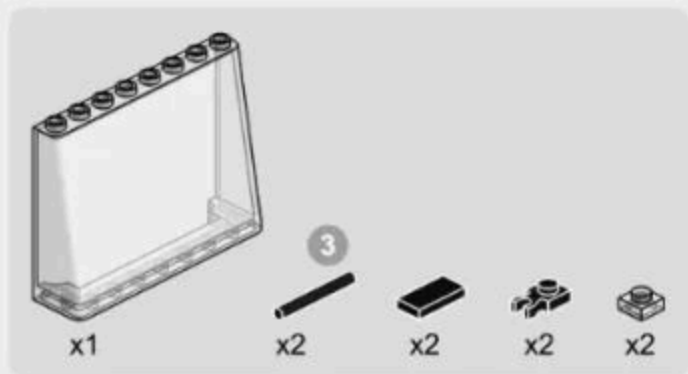

Sticker 02 03 needs to be pasted in this step  
贴纸 02 03 需在此步骤粘贴

2-17

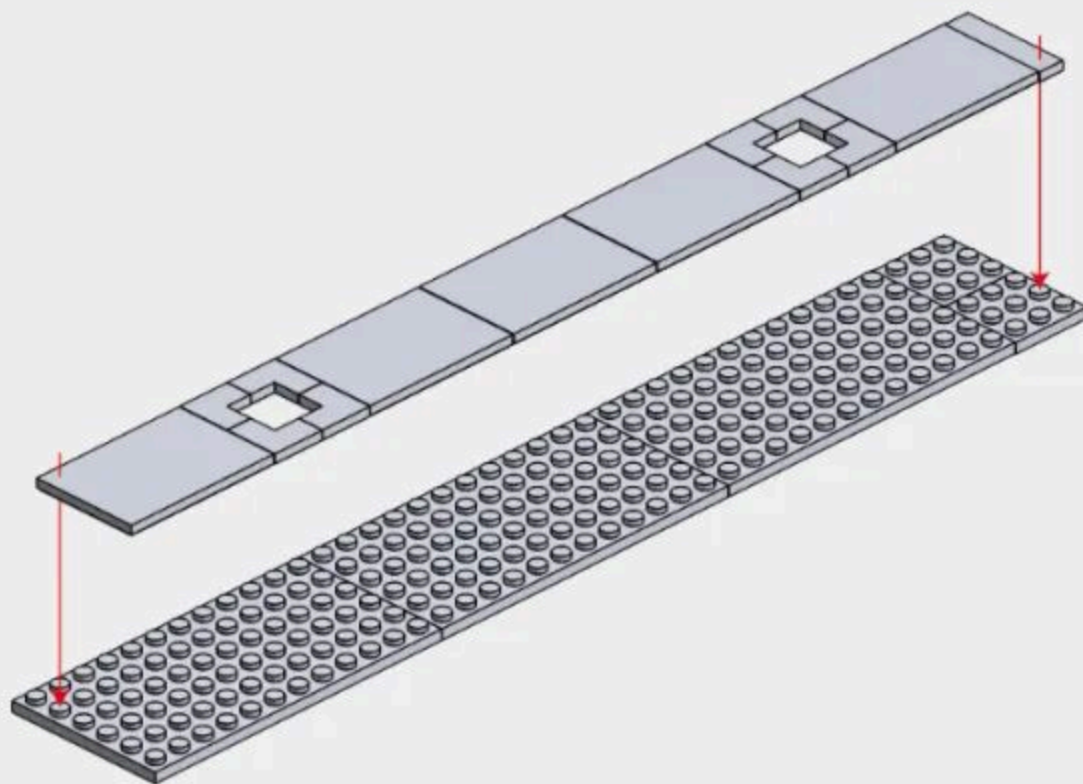
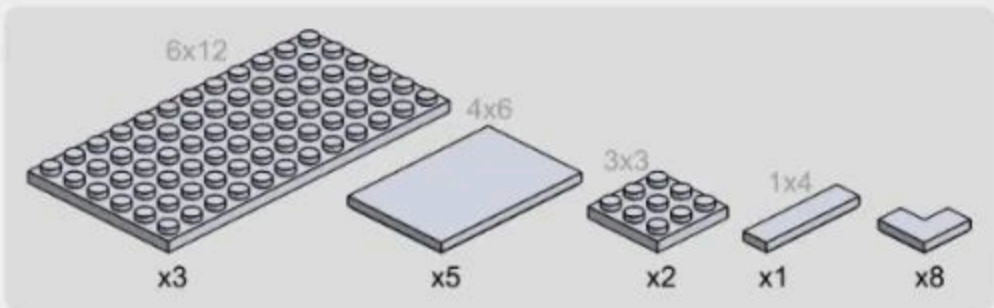

2-18

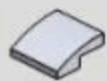

x36



x2



x2



x2



x2



x5

1

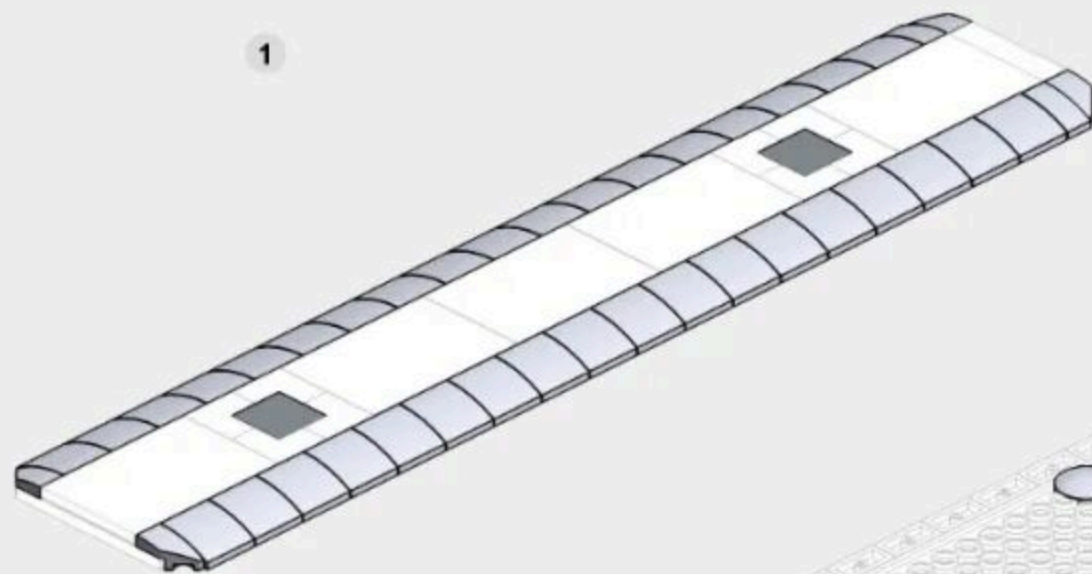

2

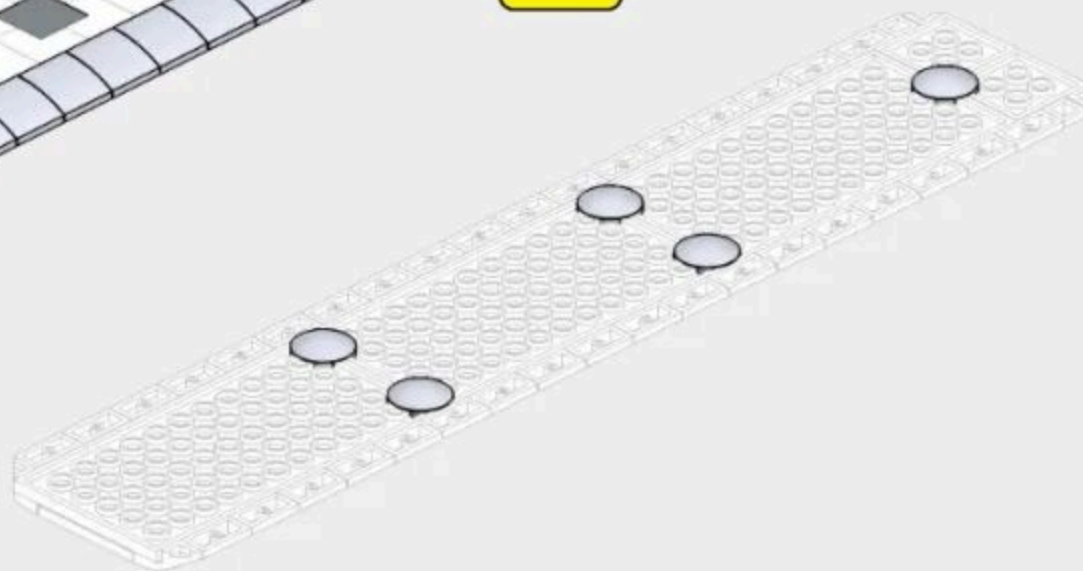

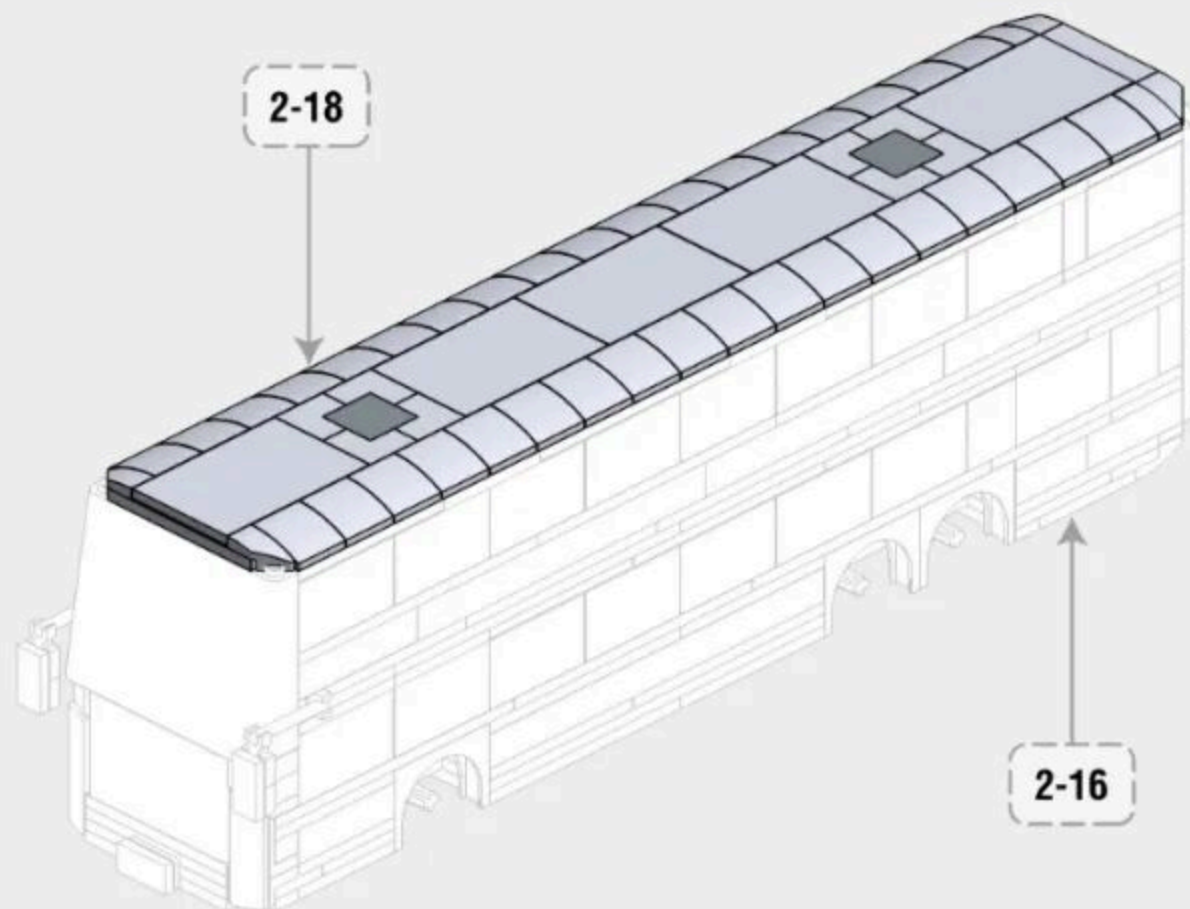

2-20

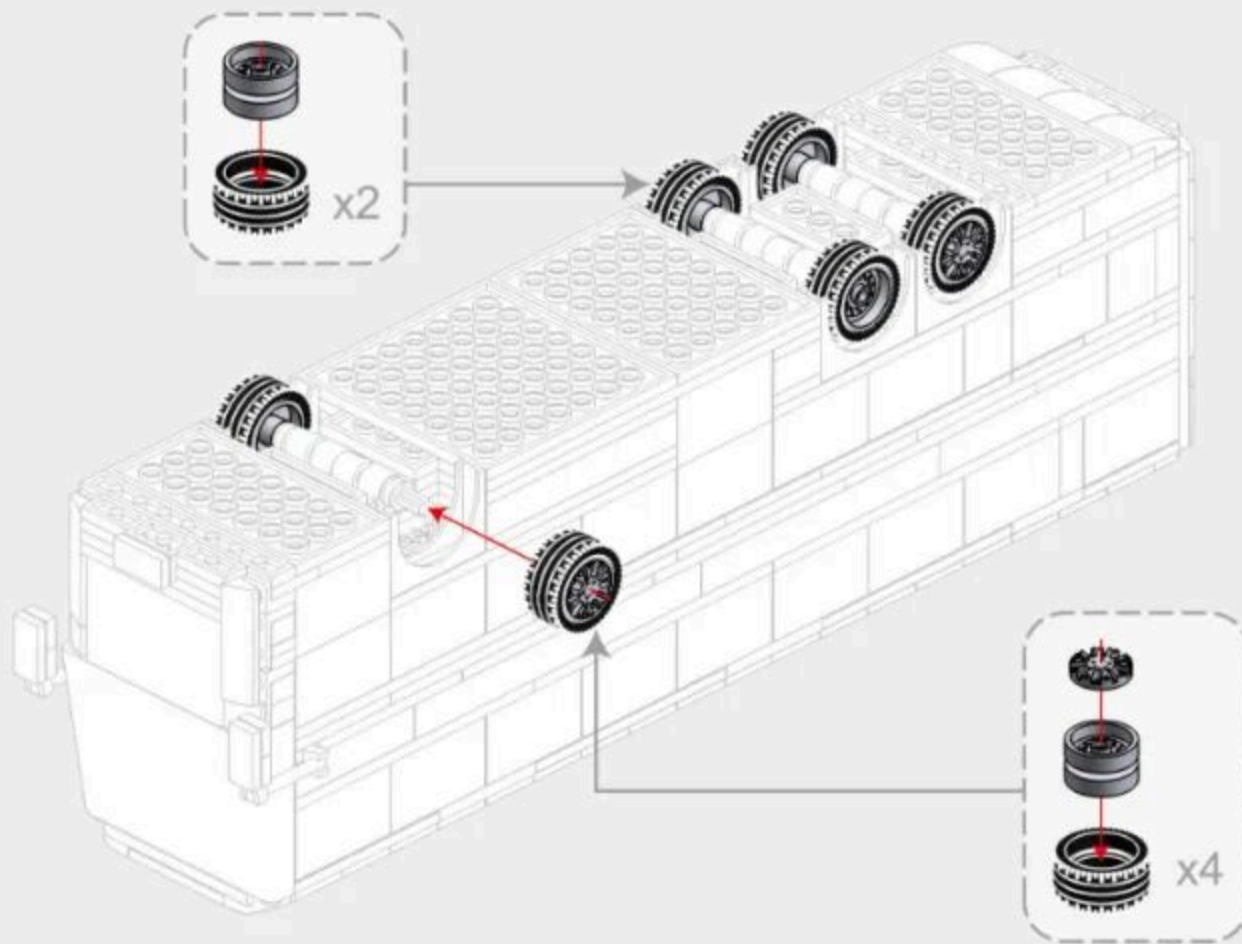

Sticker diagram  
 贴纸示意图



Sticker 04 05 Some places need to  
 be pasted on stickers 03 above  
 贴纸 04 05 部分地方需粘贴在贴纸 03 上面

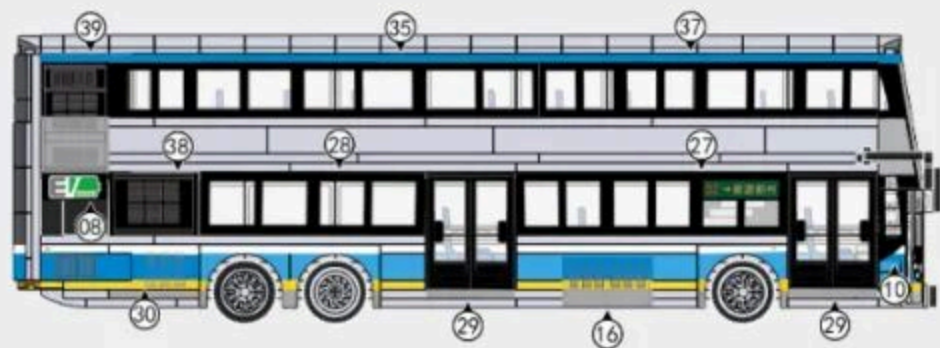

# Double-decker electric bus

Can exercise the following abilities of baby

- ★ Processing visual input through some actions. Creativity and imagination help children keep trying new ideas.
- ★ Help them gradually form an innovative thinking and constantly find new ways to solve problems.
- ★ It is conducive to the development of "space wisdom".

Ver.497420241120