



THE EIFFEL TOWER OF PARIS

France
The world's great architecture

Ages
6+



Creative Ability

Family Interaction

Observation Ability

Thinking Ability

Practical Ability



NO.5217

1002 PCS

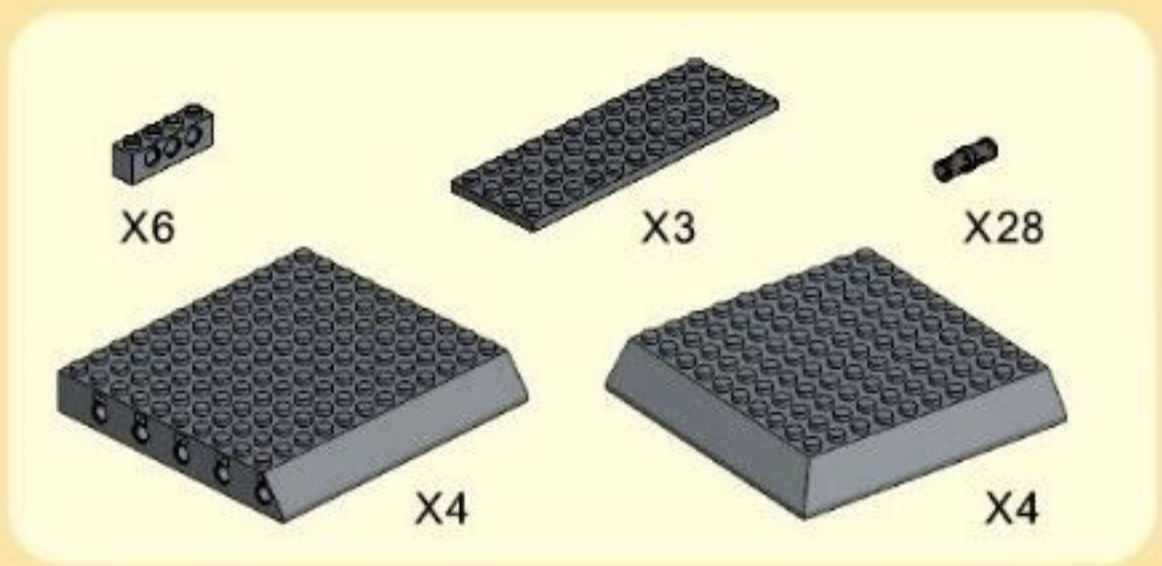

1

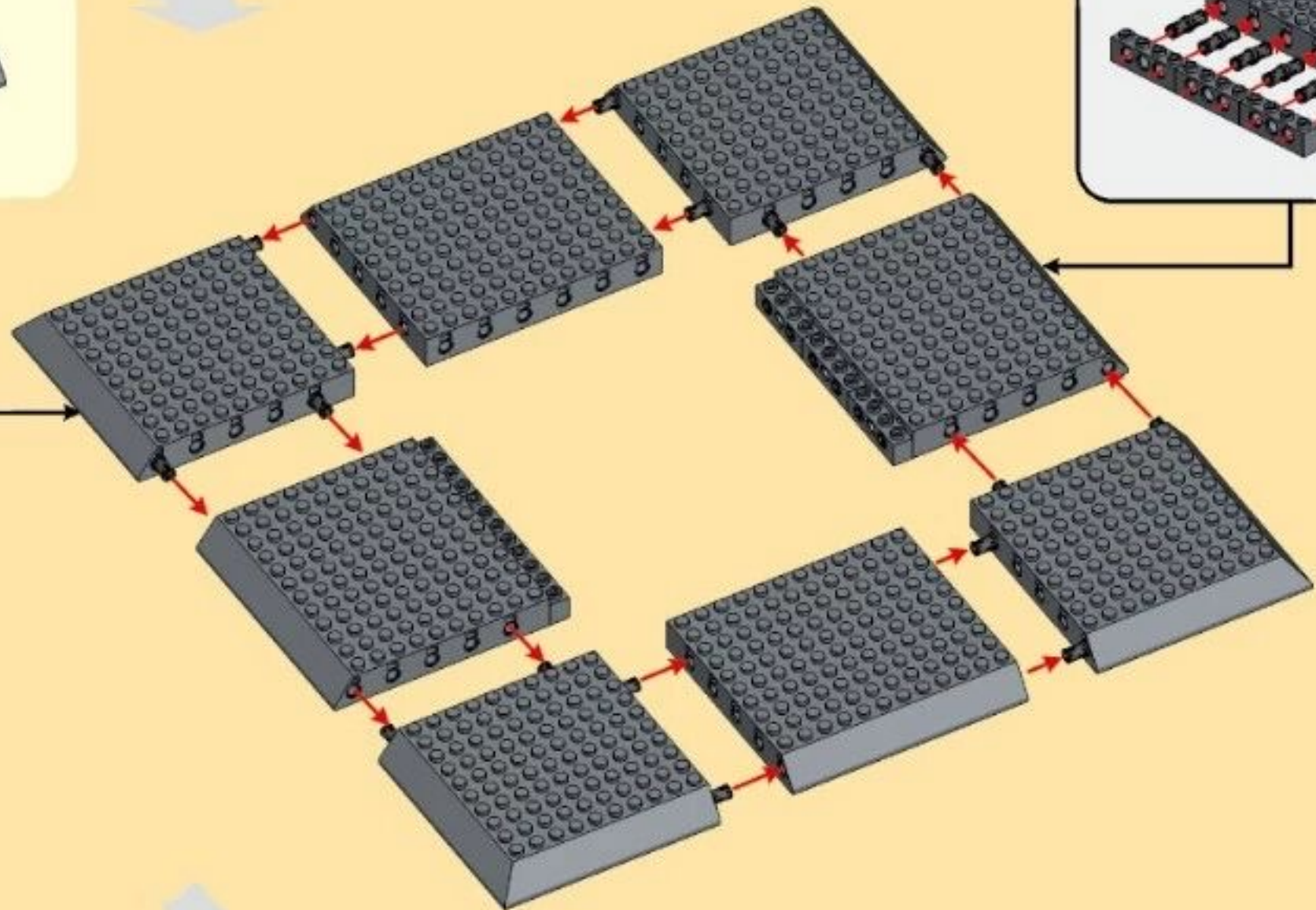
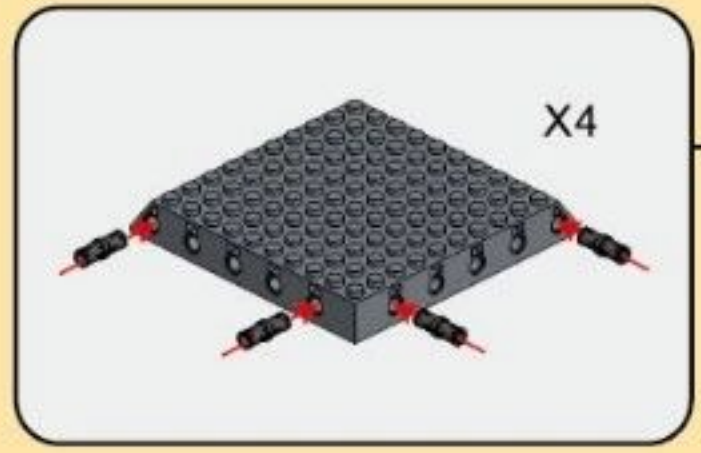
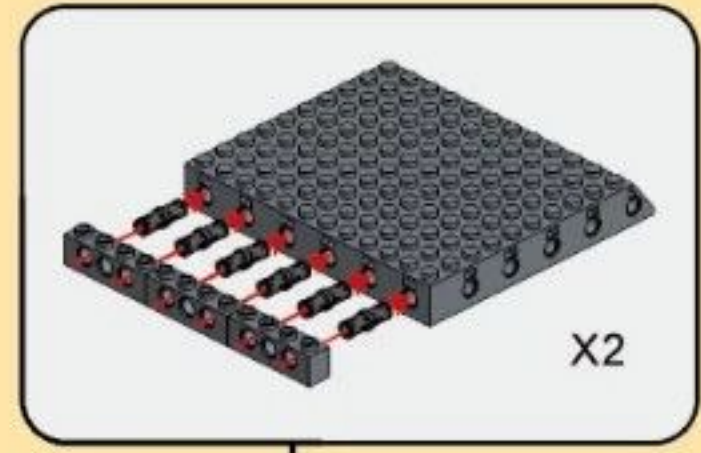

A

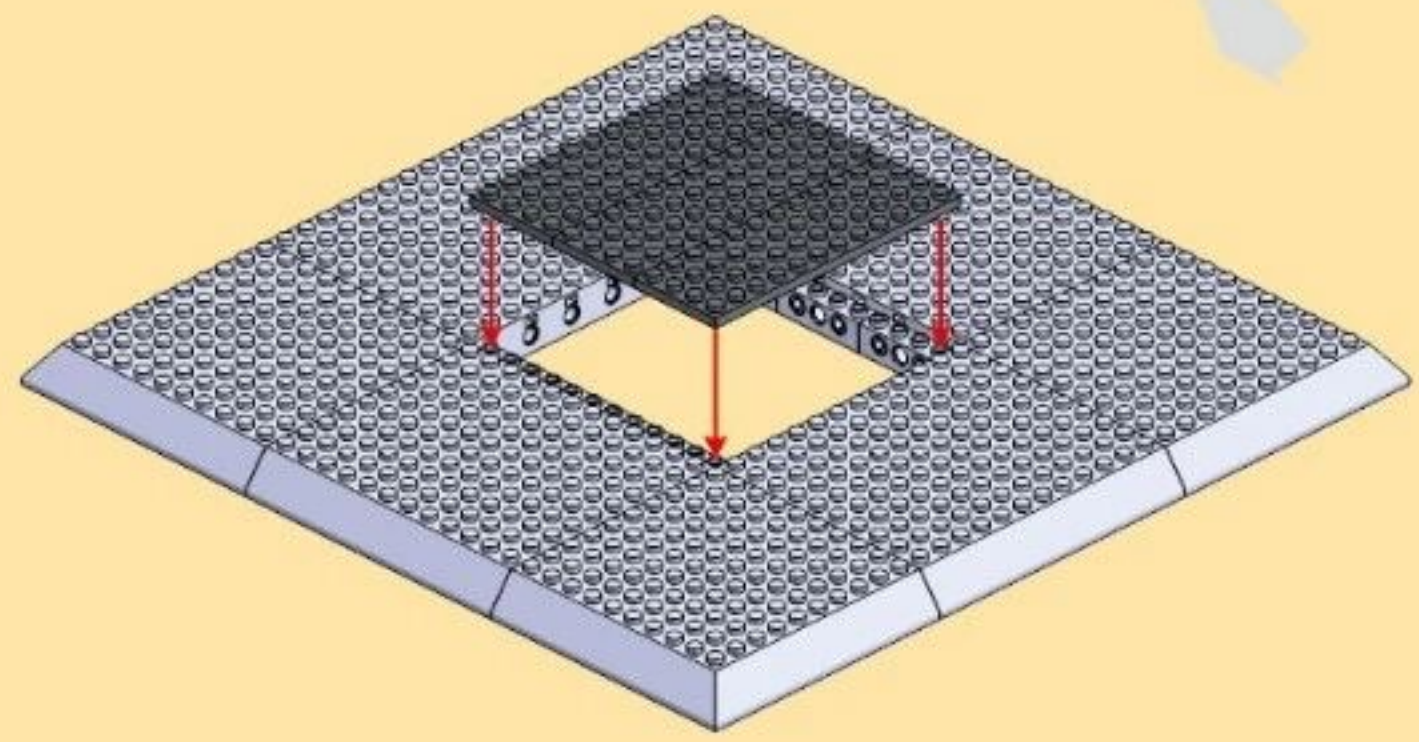

B

1

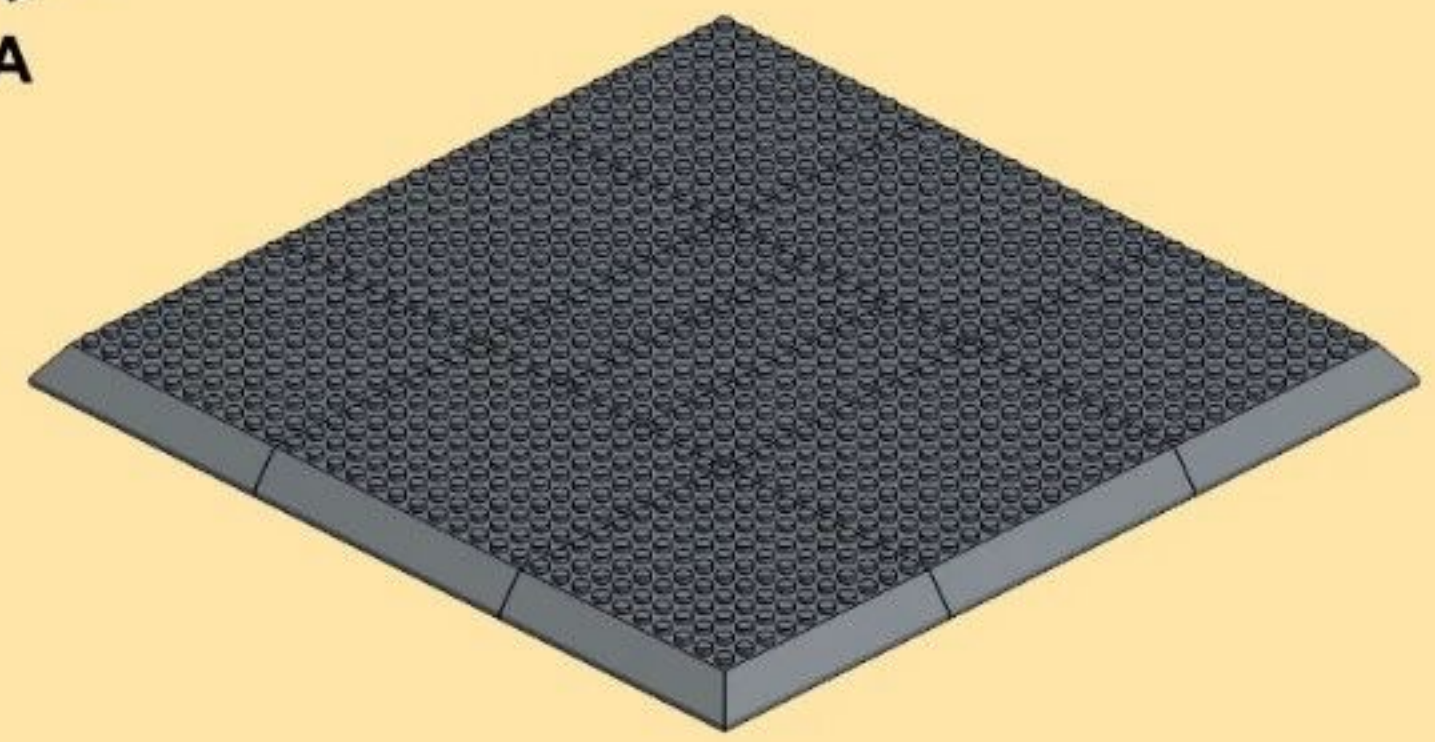

C



2

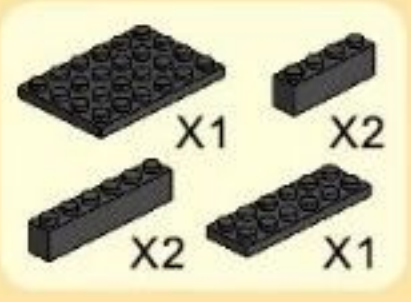

A

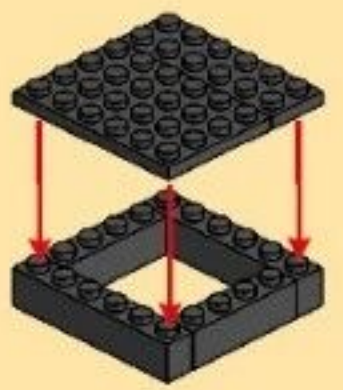

B

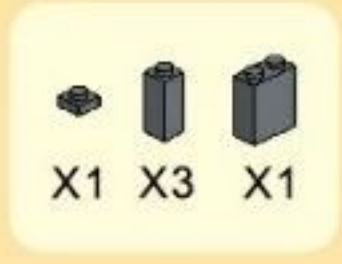

C

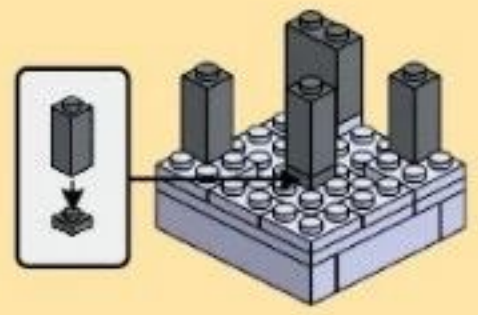

D

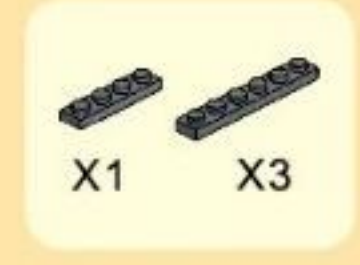
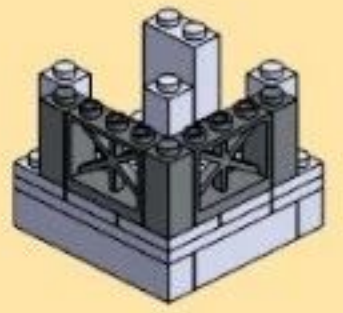

E

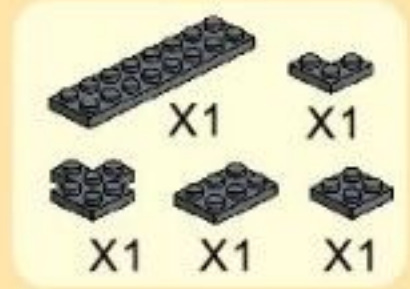
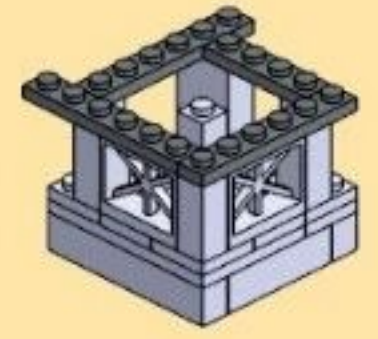

F

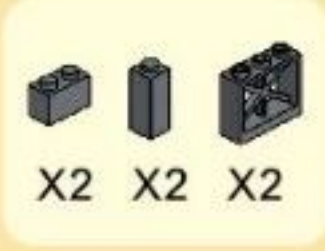
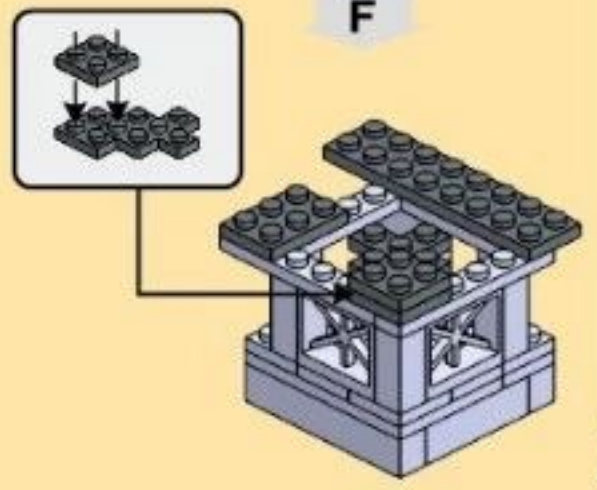

G

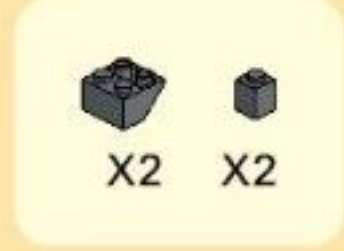
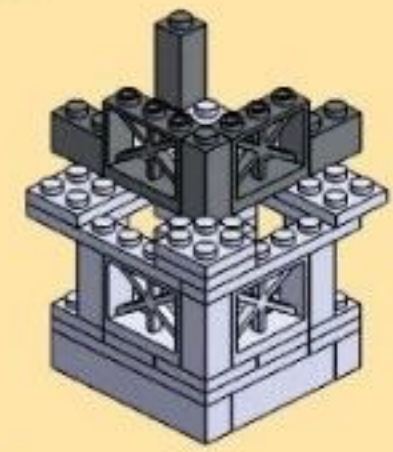

H

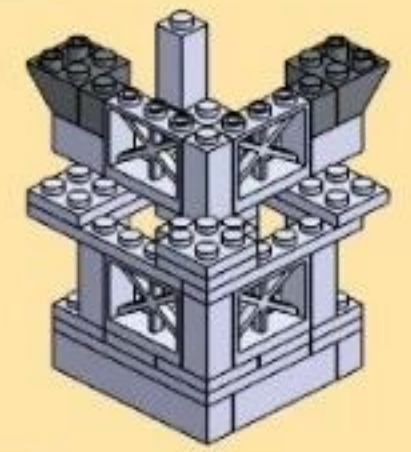

I

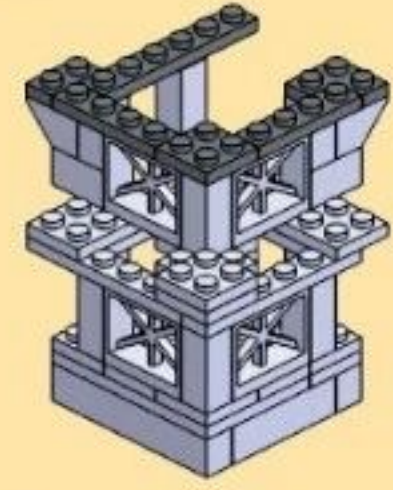

J

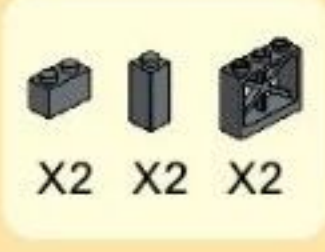

K

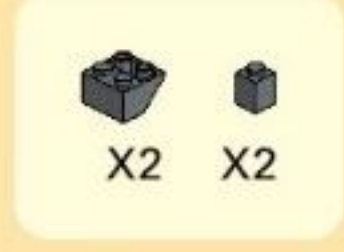
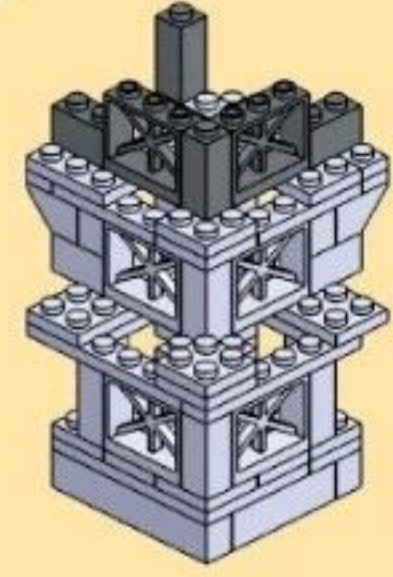

L

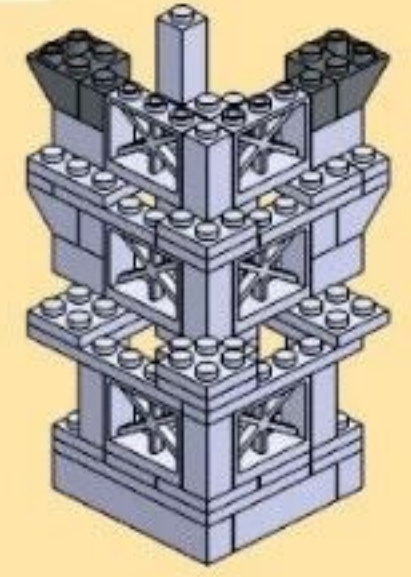

2

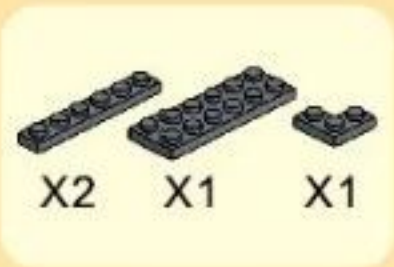

M

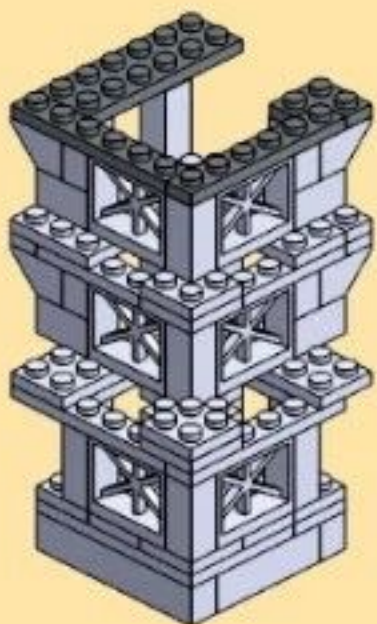

N

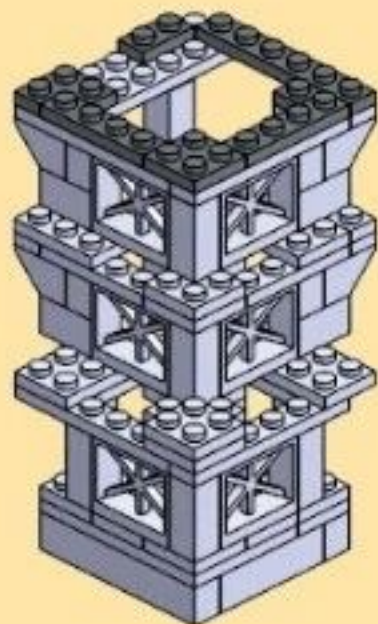

O

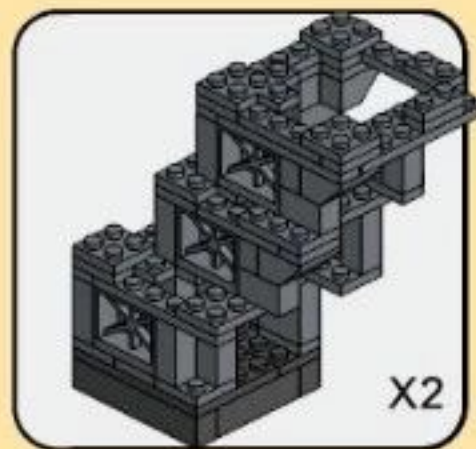
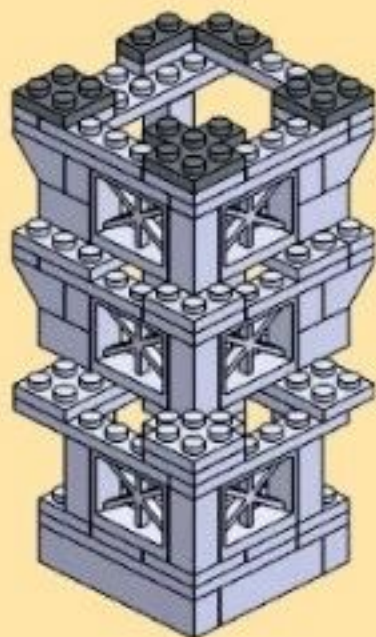

3

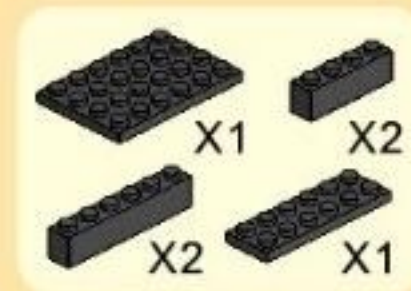
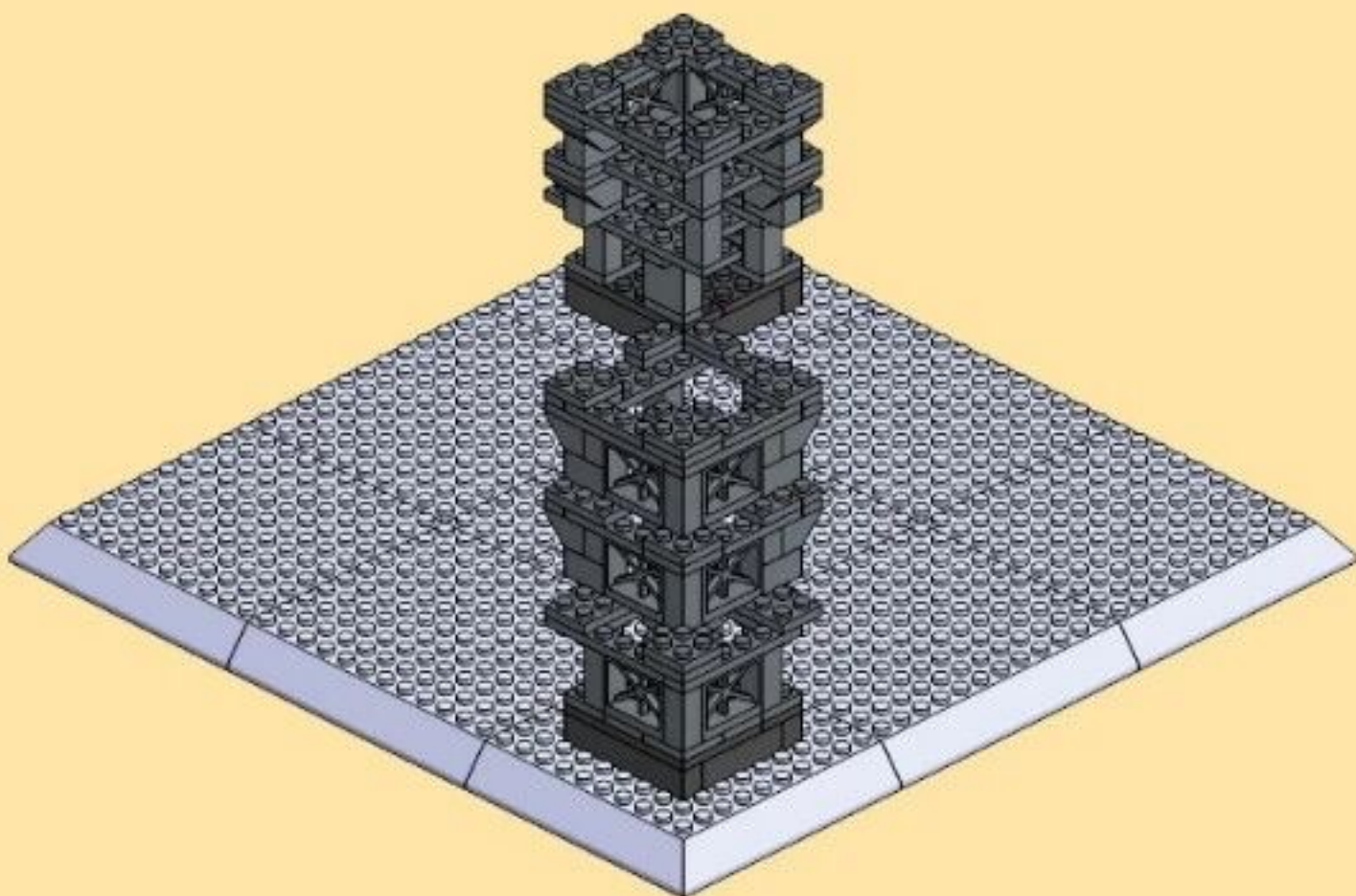

A

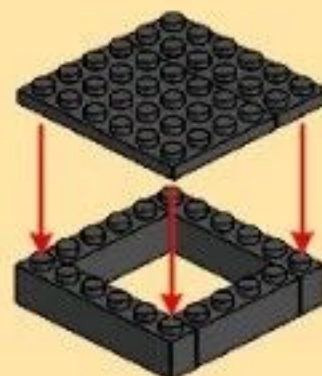

B

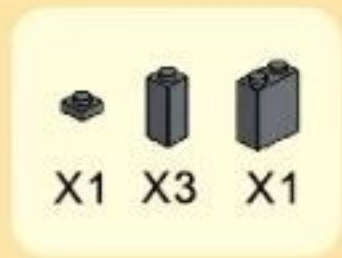

C

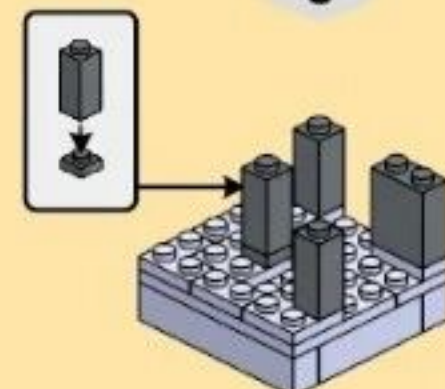

D

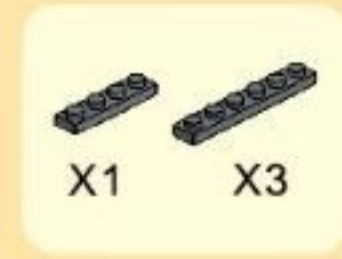
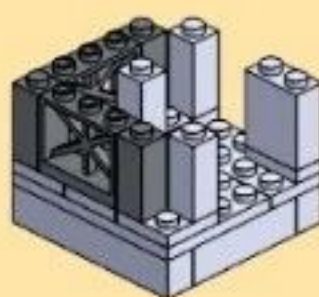

E

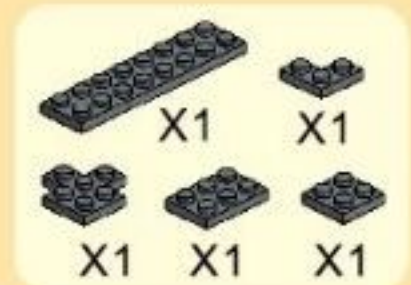

F

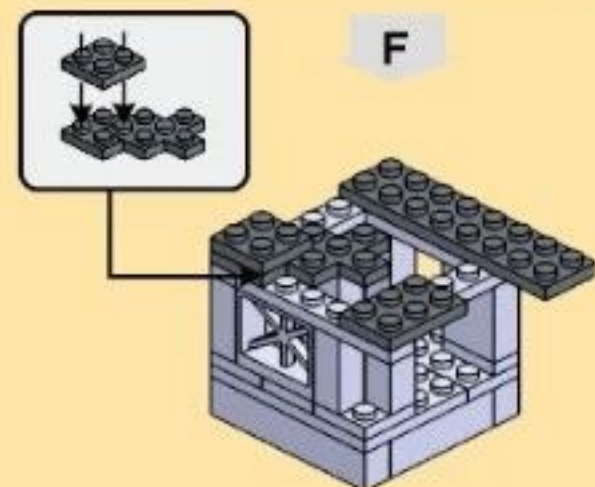

3

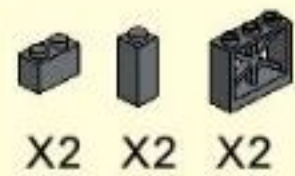

G

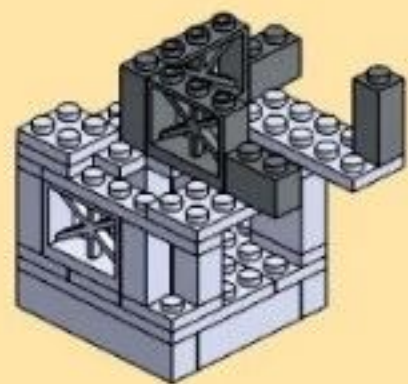

H

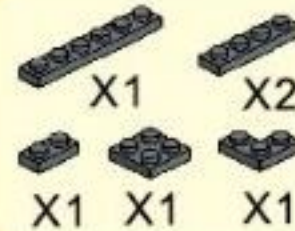
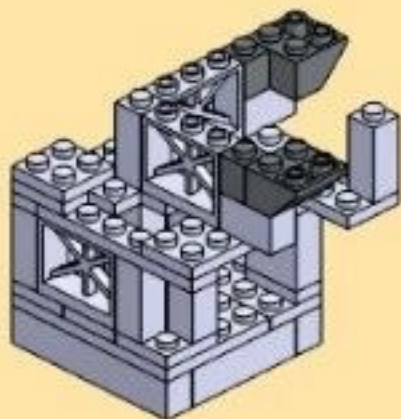

I

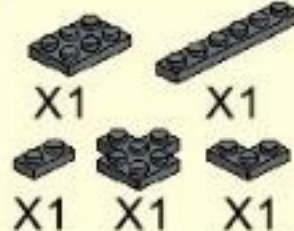
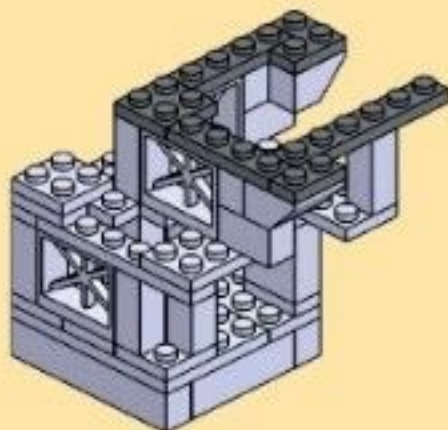

J

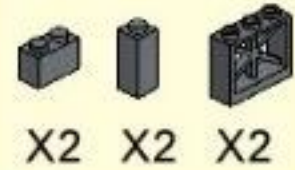
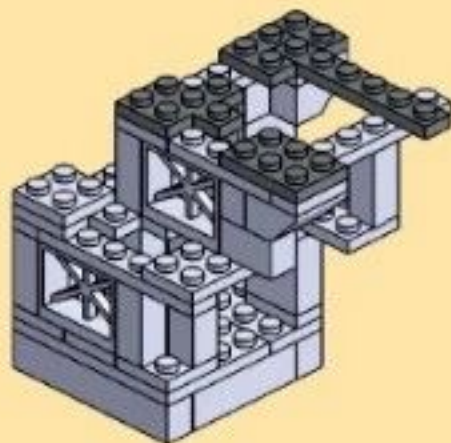

K

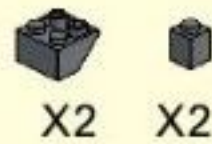
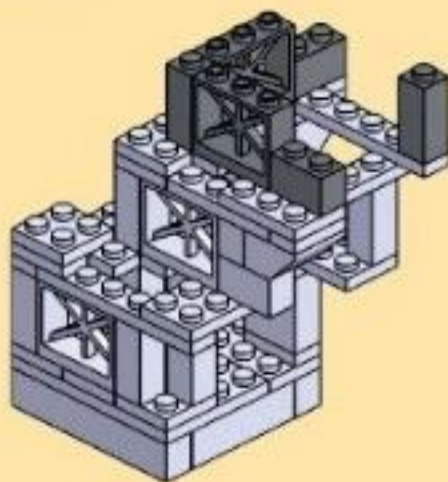

L

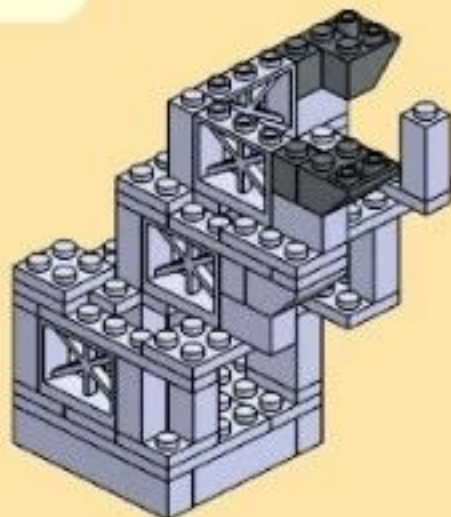

M

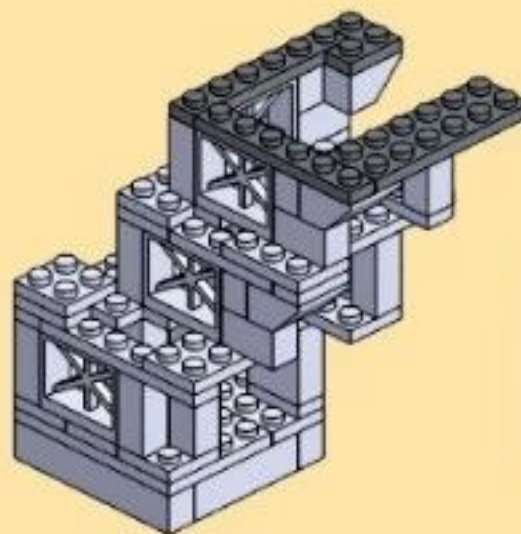

N

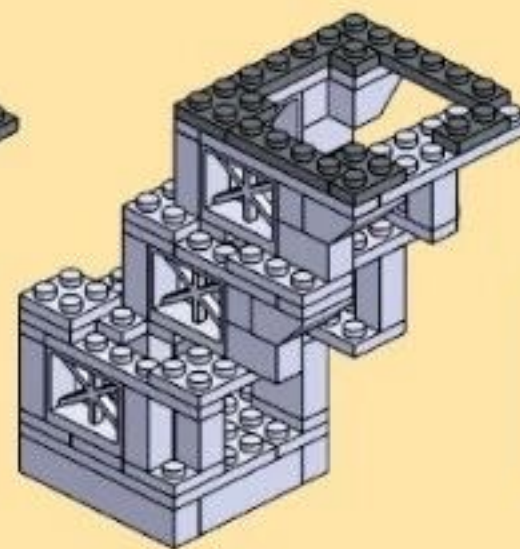

O

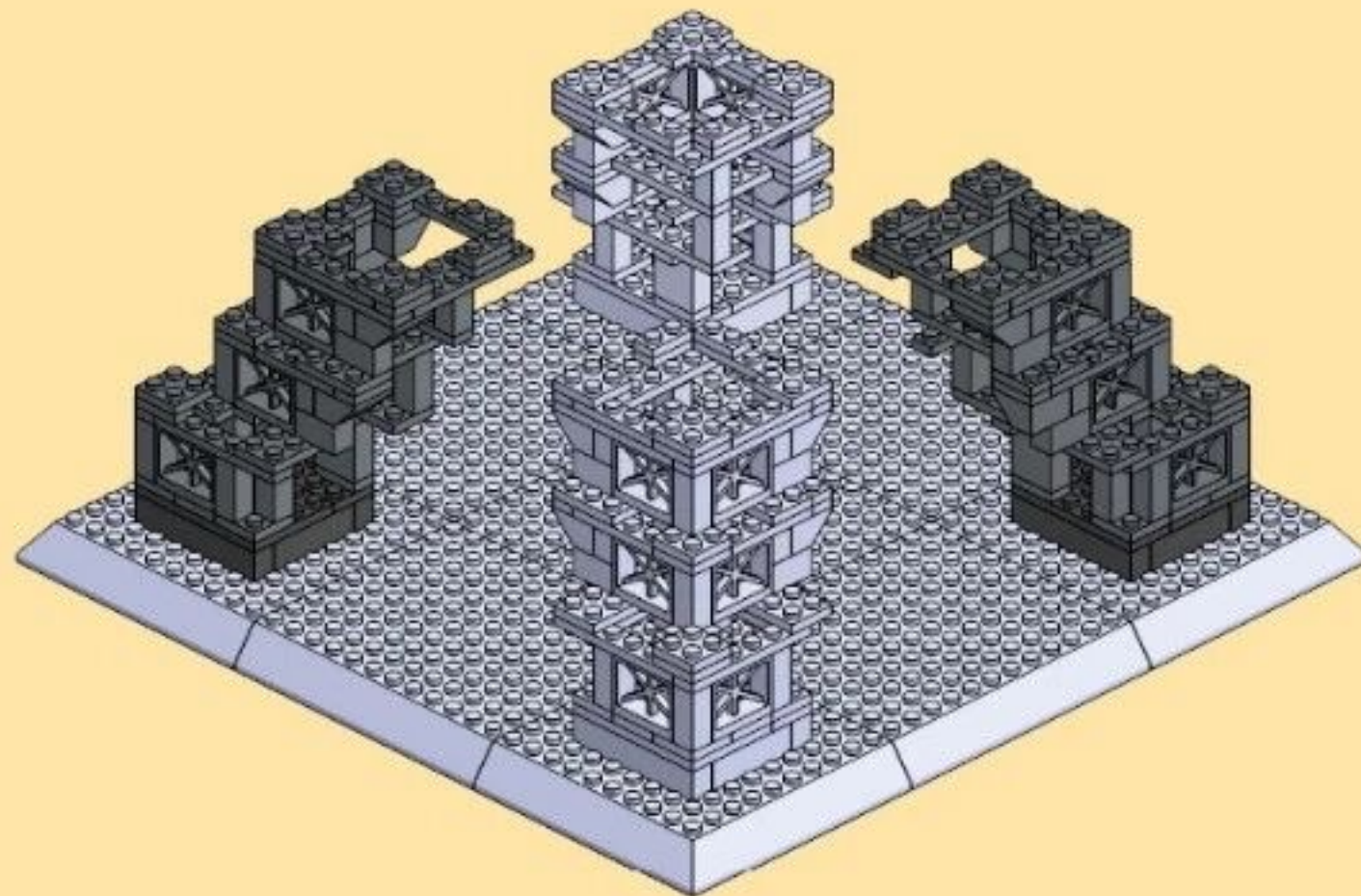
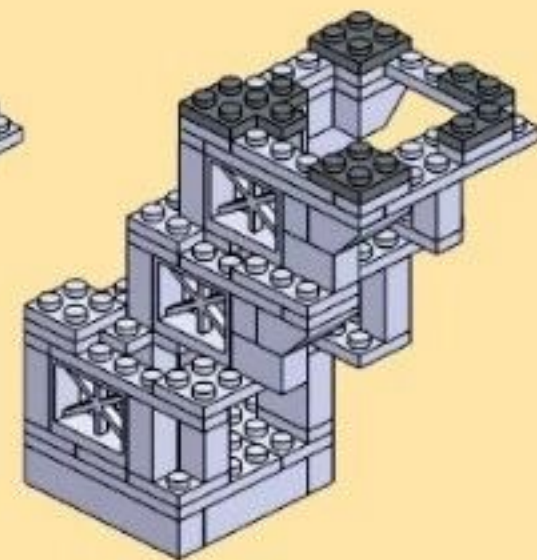

- X4 [Small black pin]
- X4 [Long black axle]
- X12 [Small black bush]

4

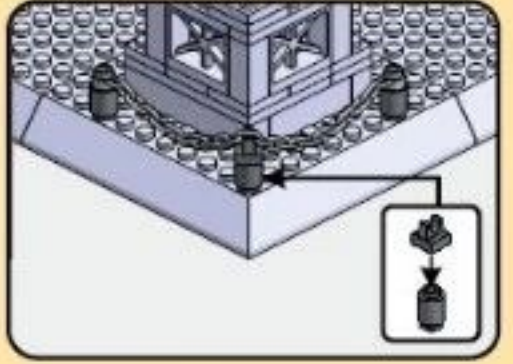

- X4 [Black 1x4 Technic beam]
- X8 [Black 1x8 Technic beam]
- X8 [Black 1x8 Technic beam]
- X4 [Black 1x4 Technic beam]
- X4 [Black 1x4 Technic beam]
- X4 [Black 1x4 Technic beam]

5

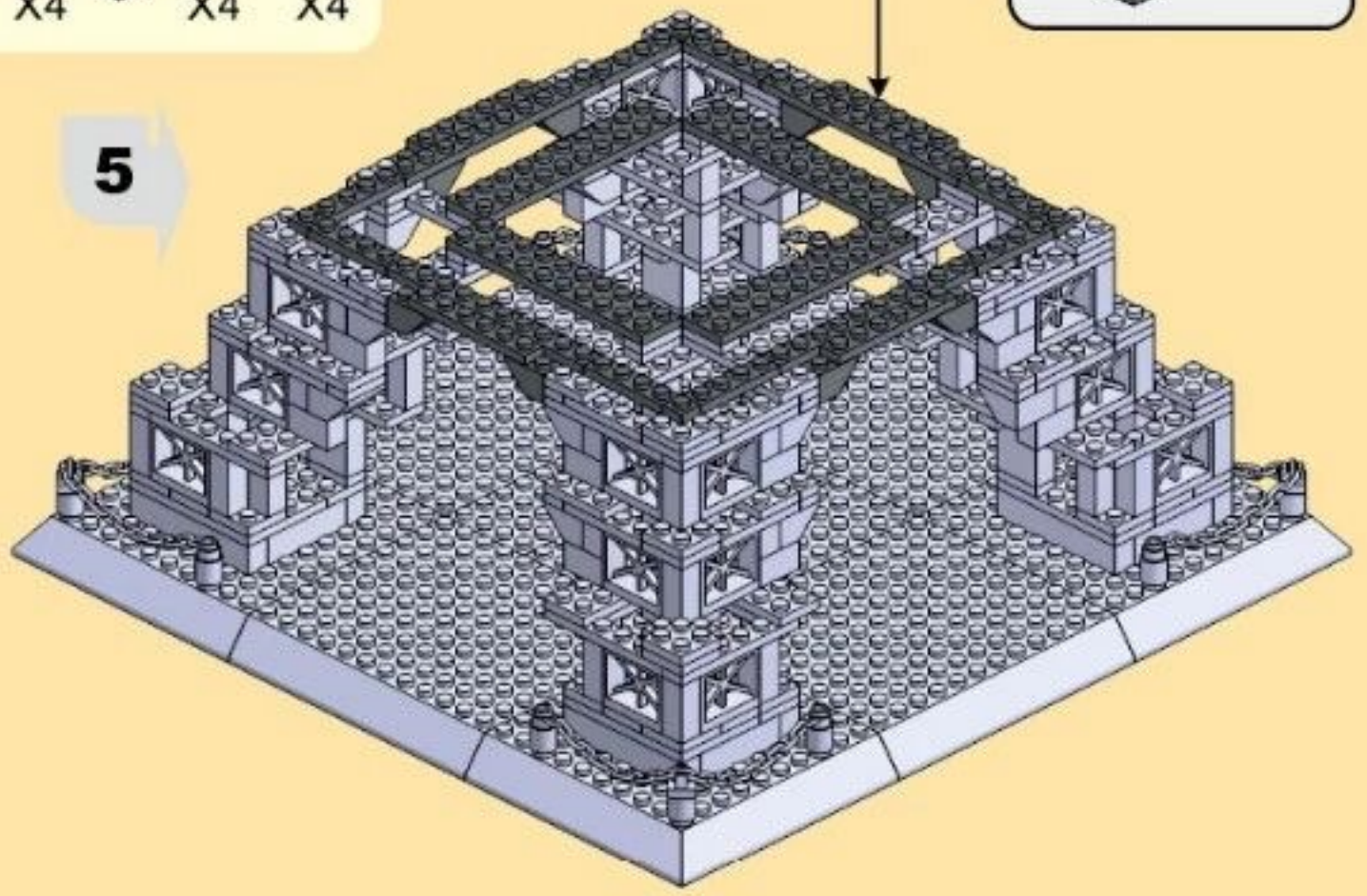

- X4 [Black 1x2 Technic brick with hole]
- X4 [Black 1x2 Technic brick with hole]
- X8 [Black 1x2 Technic brick with hole]
- X6 [Black 1x2 Technic brick with hole]
- X16 [Black 1x2 Technic brick with hole]

6

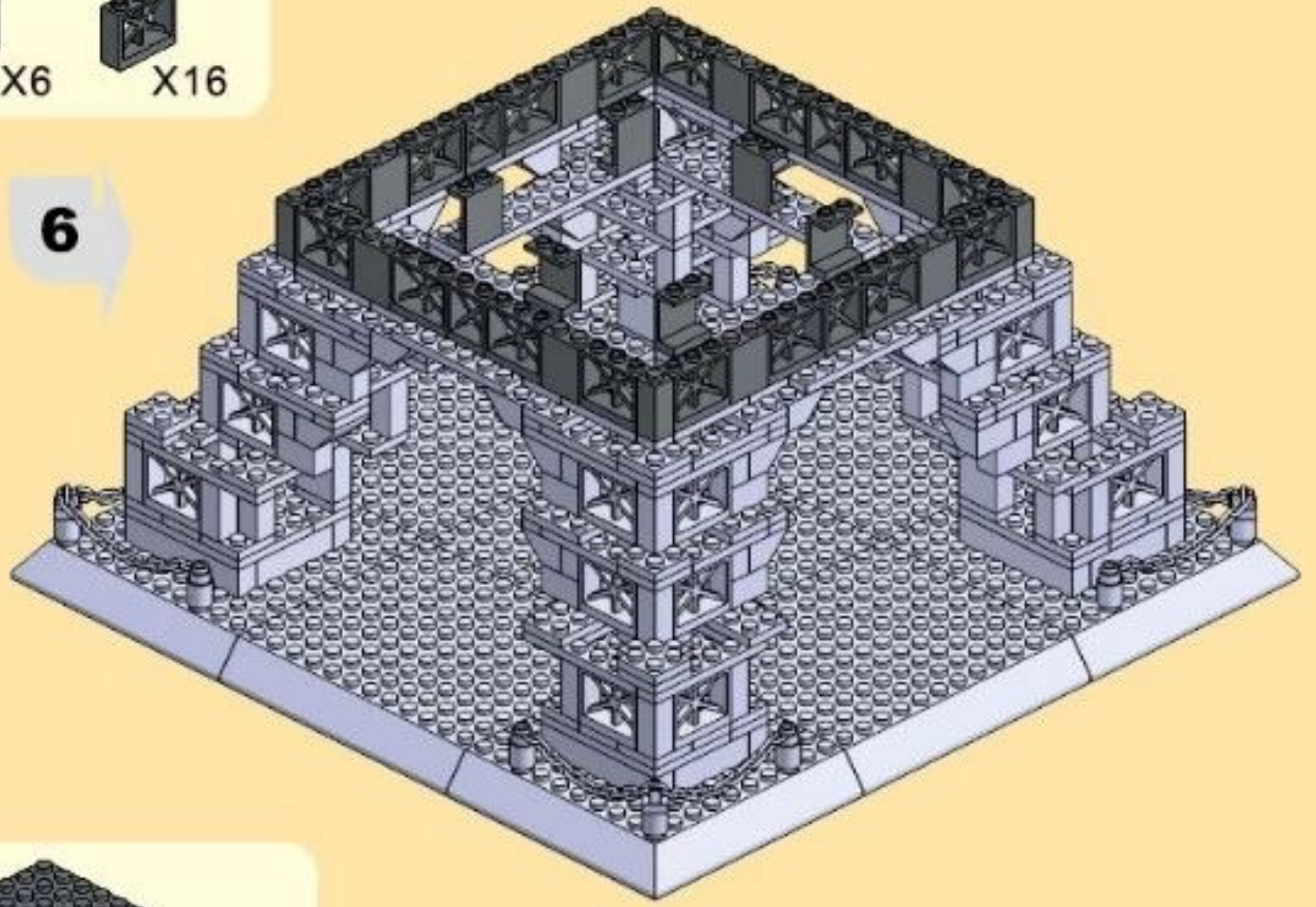

- X2 [Black 1x8 Technic plate]
- X4 [Black 1x8 Technic plate]

7

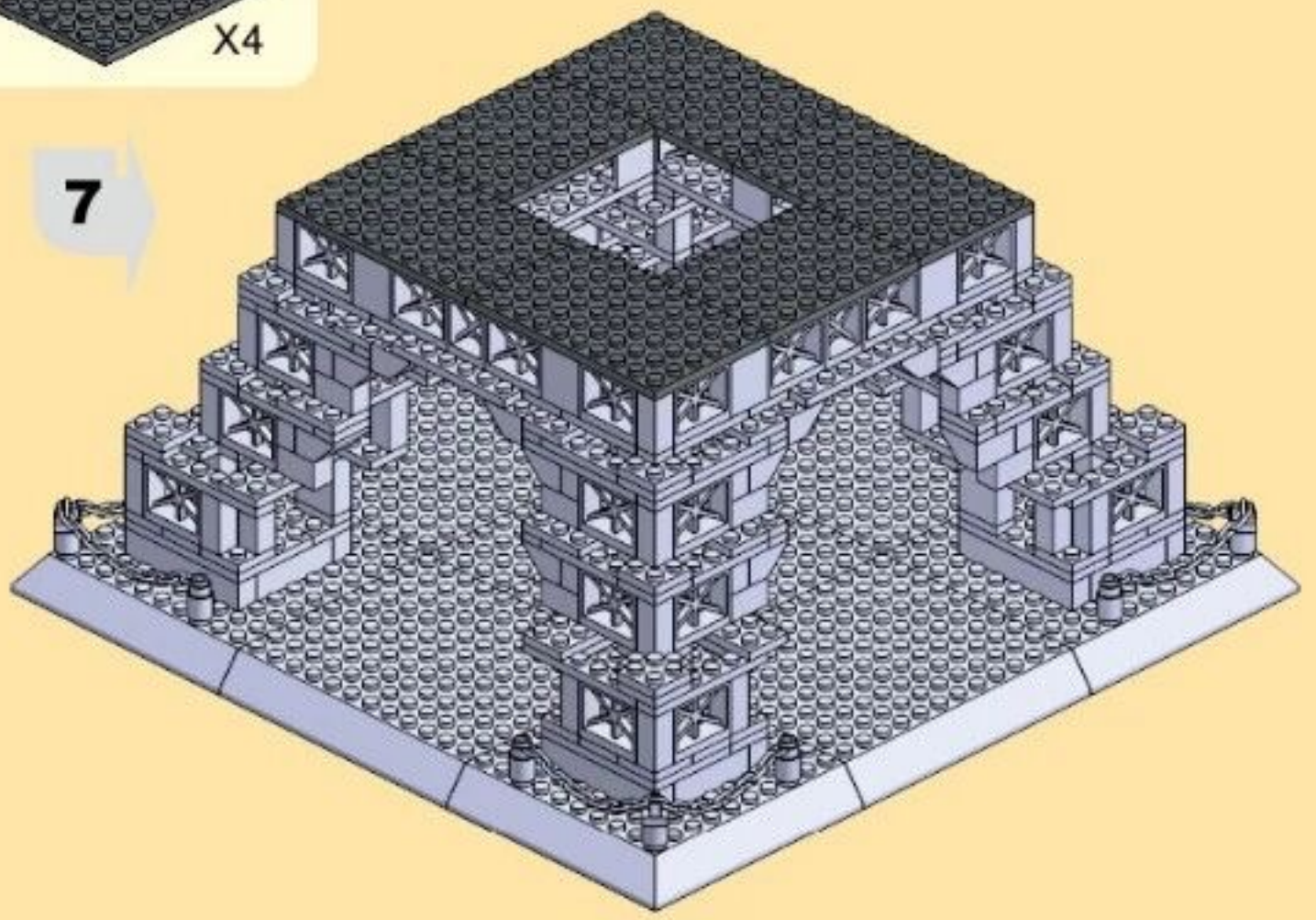

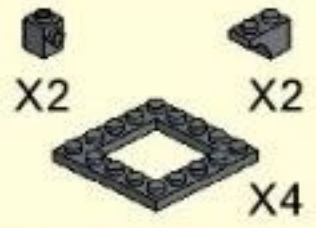

8

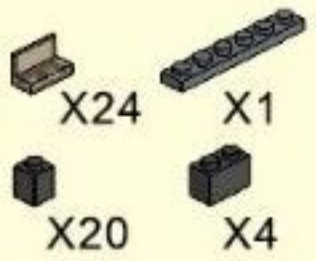
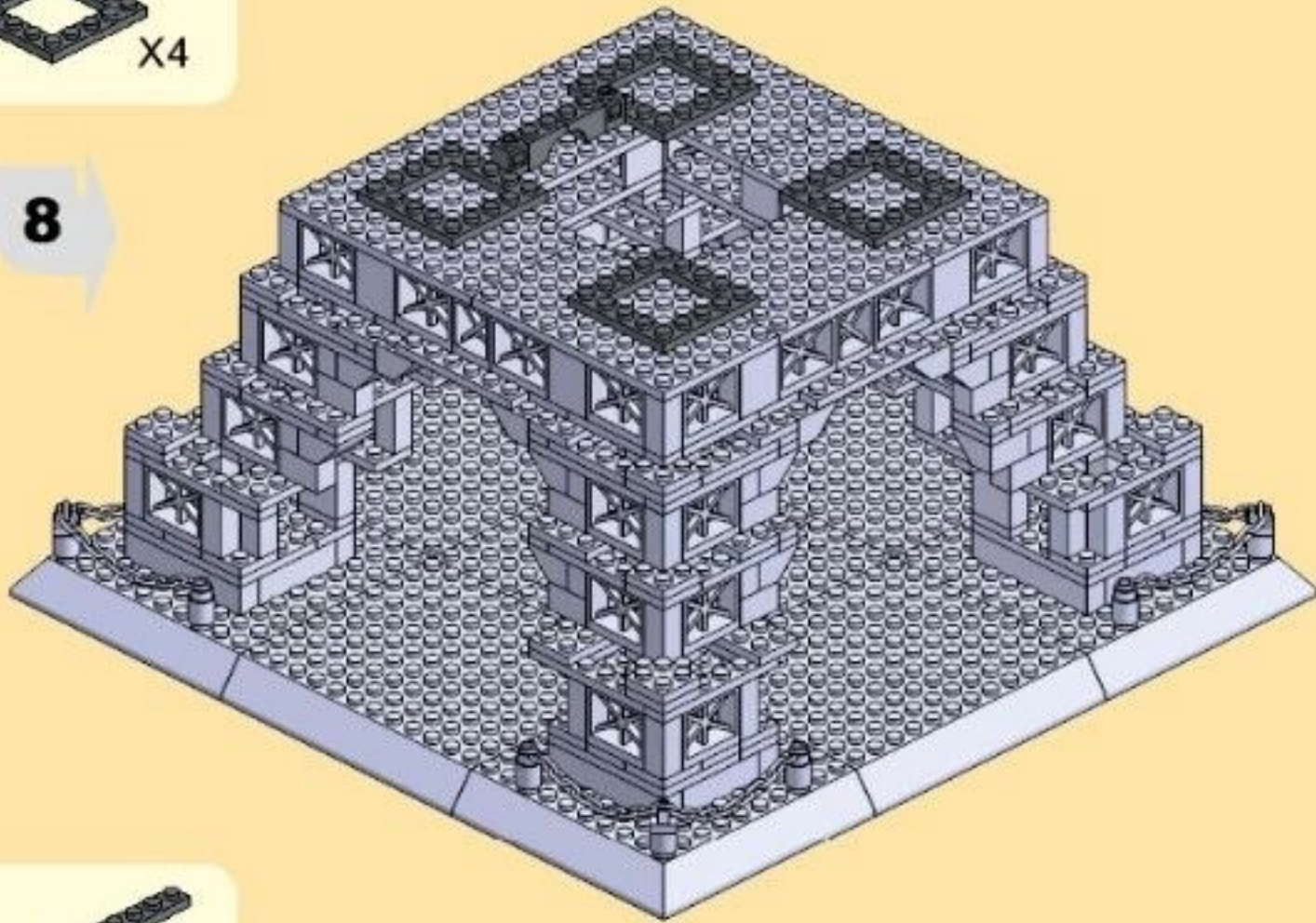

9

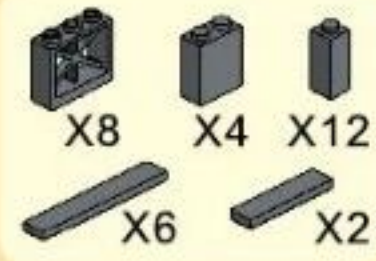
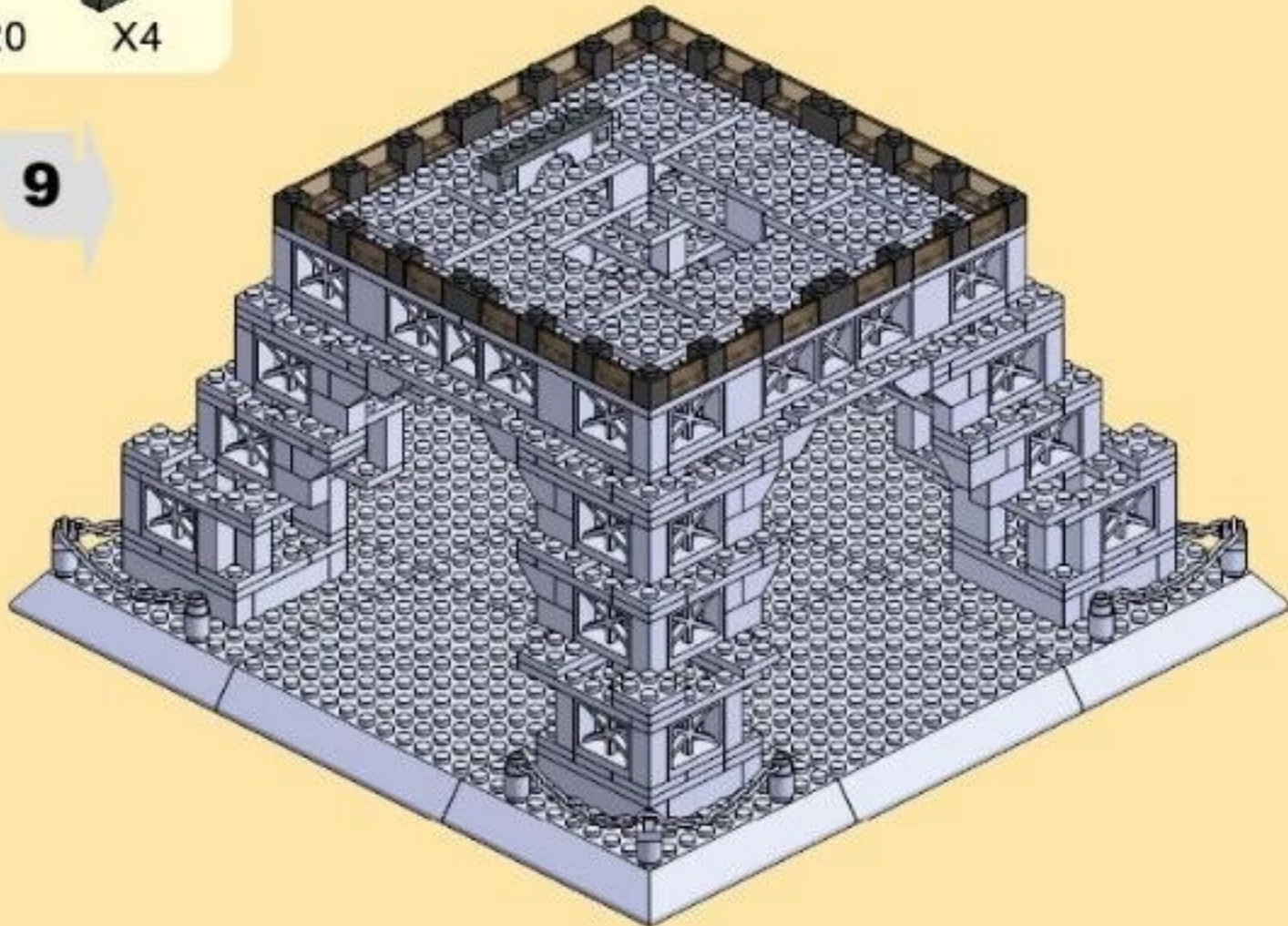

10

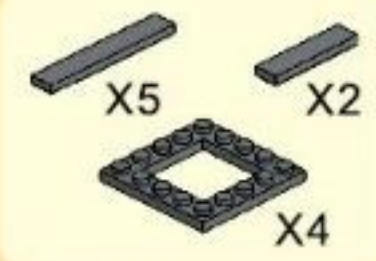
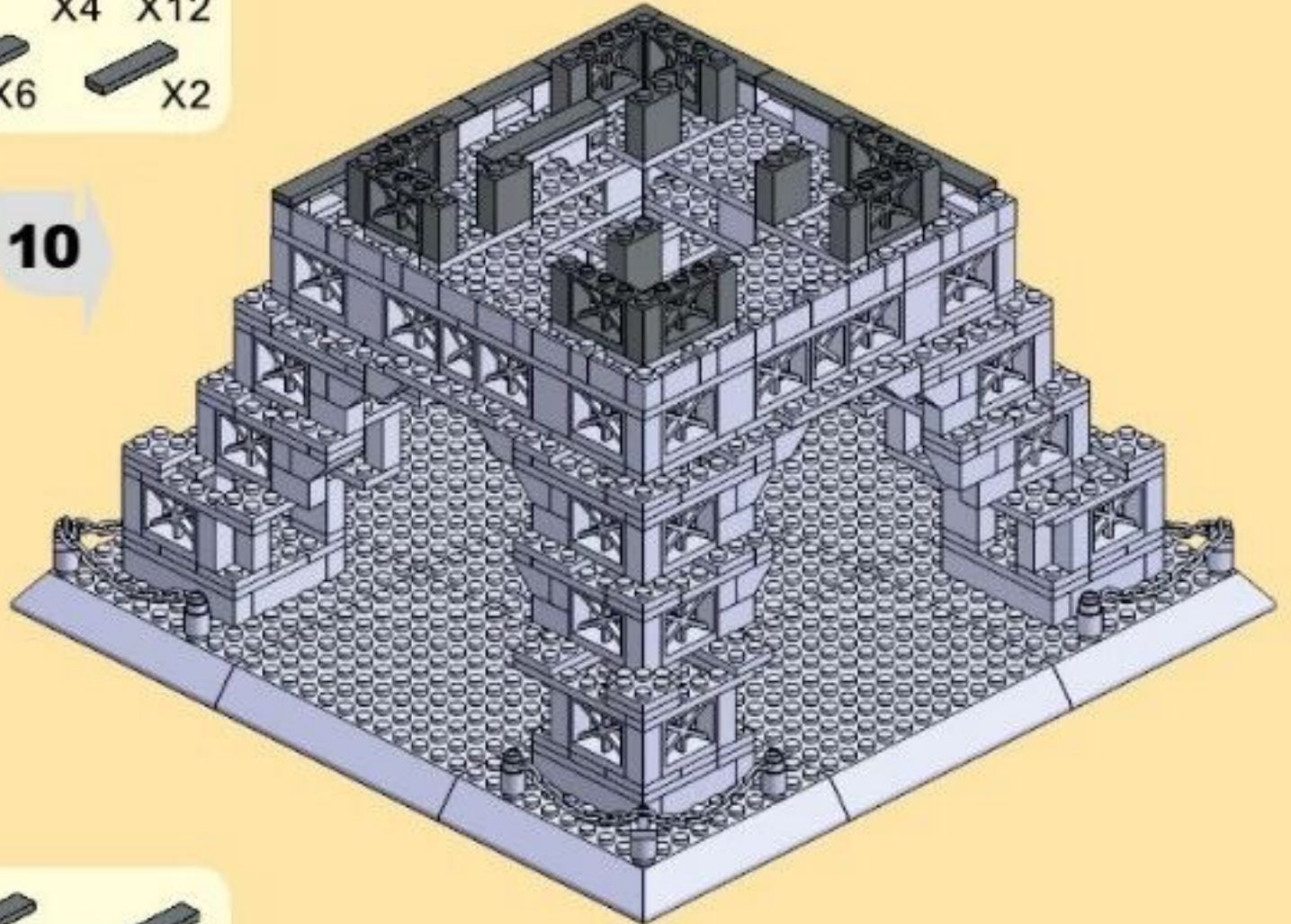

11

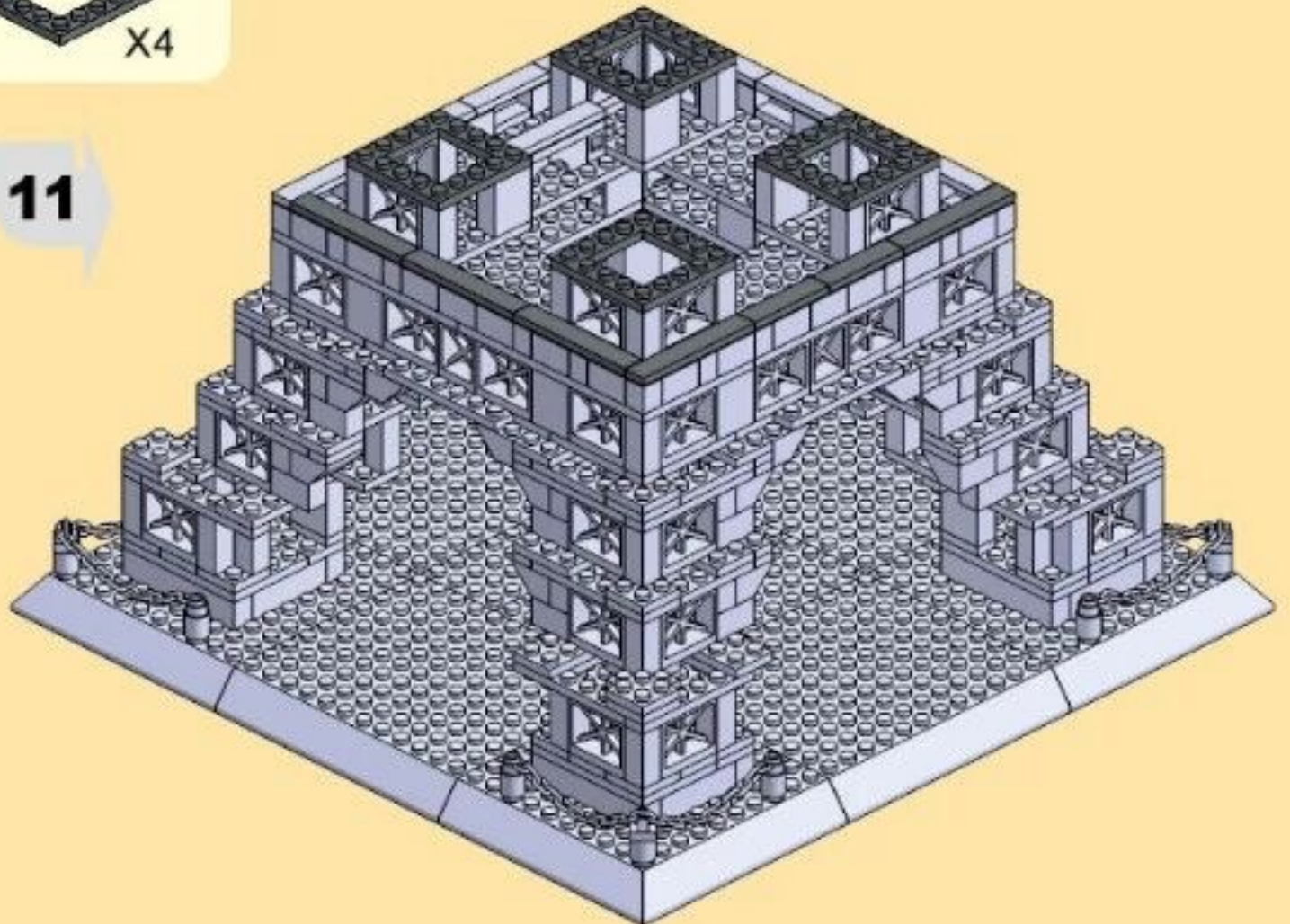

X4 X12

12

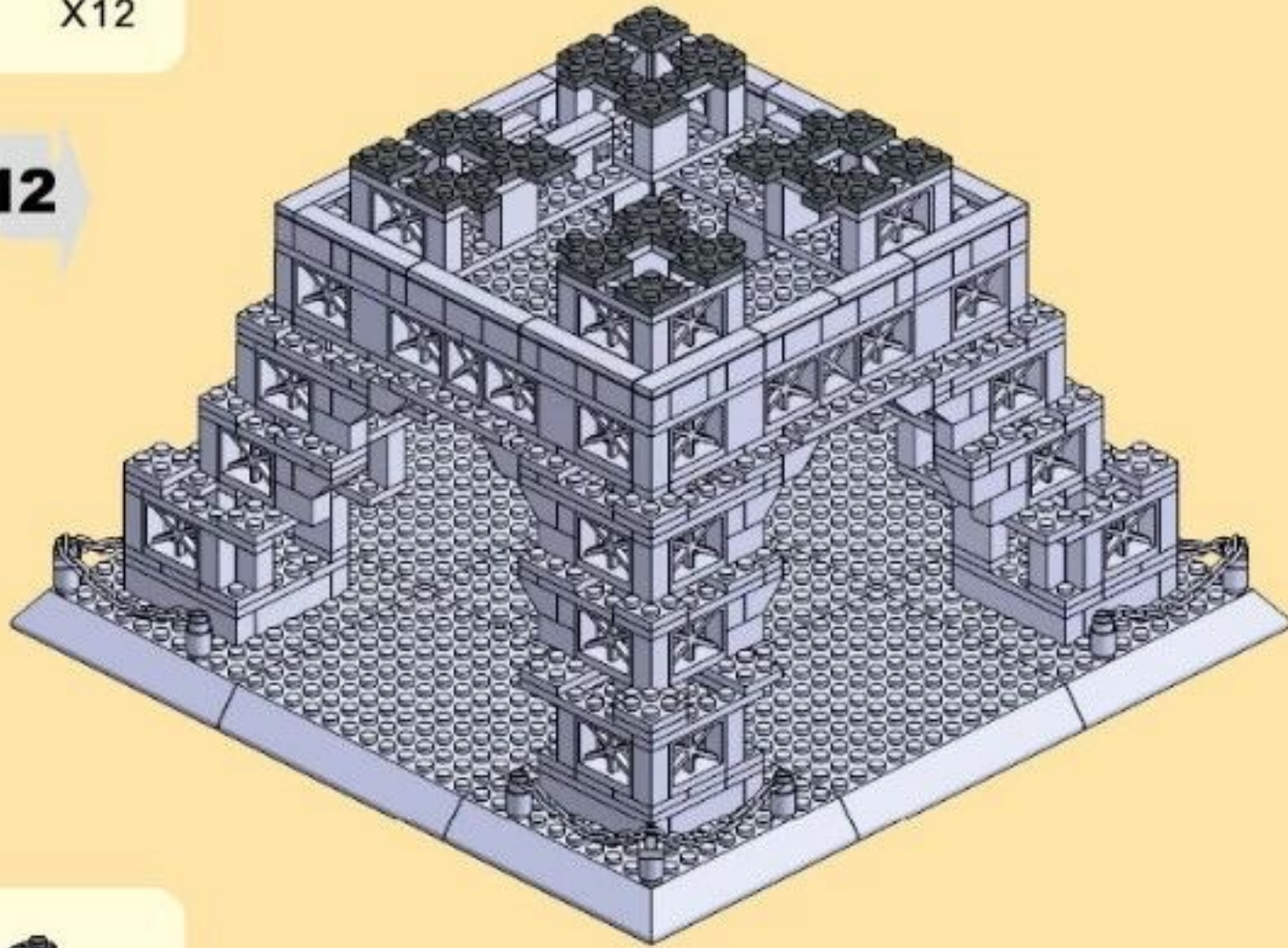

X4

13

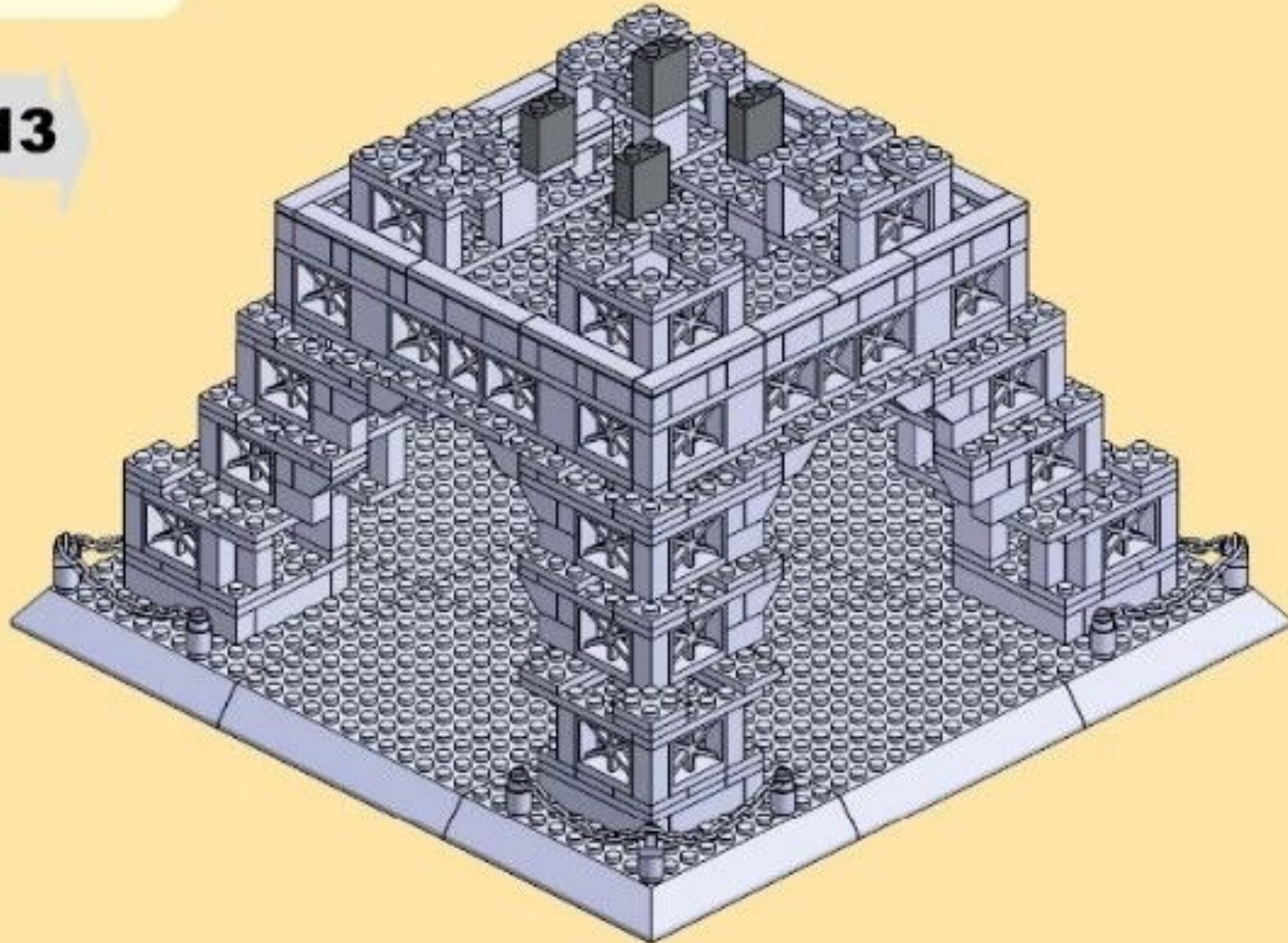

X8 X12

14

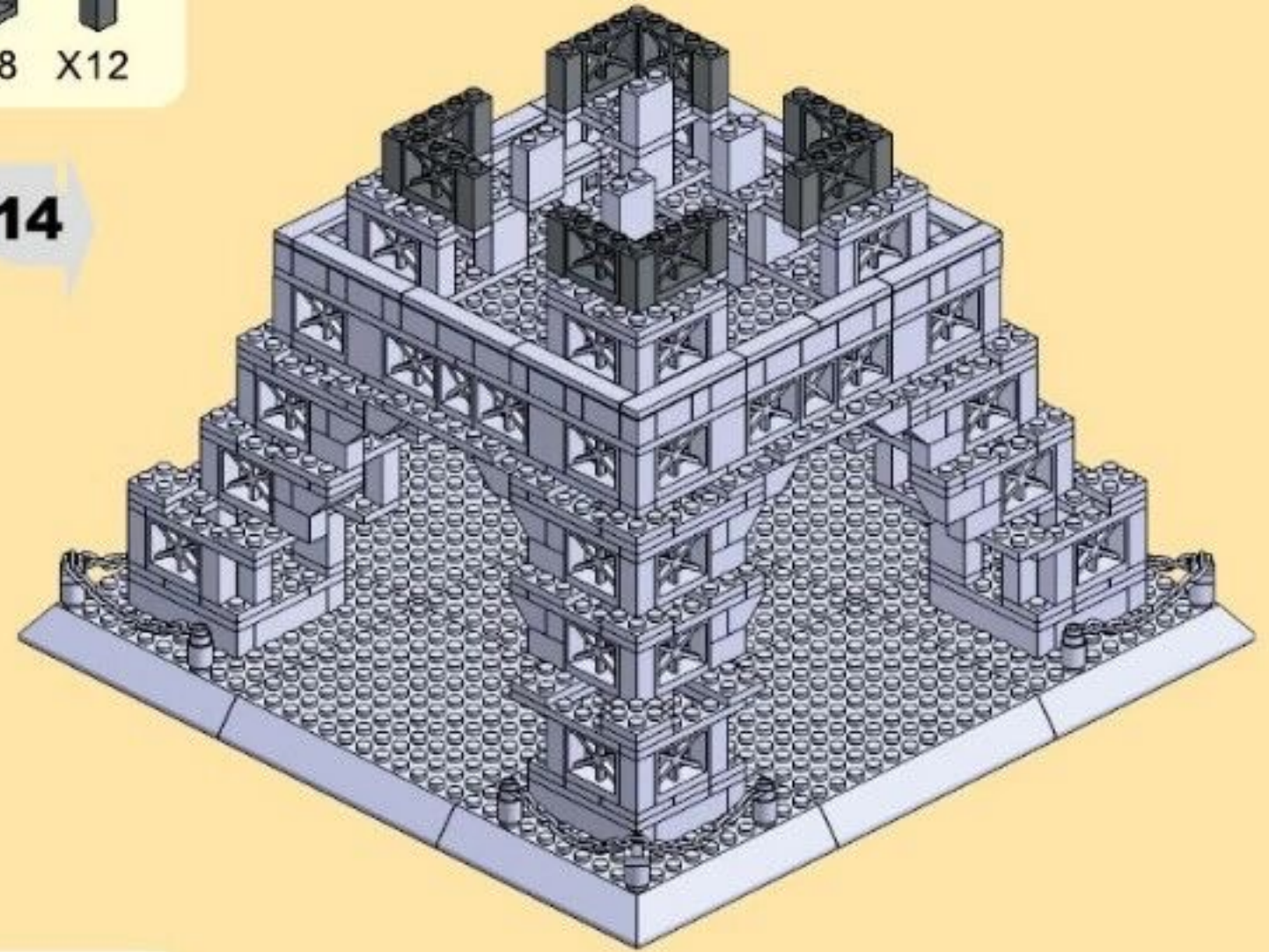

X4

15

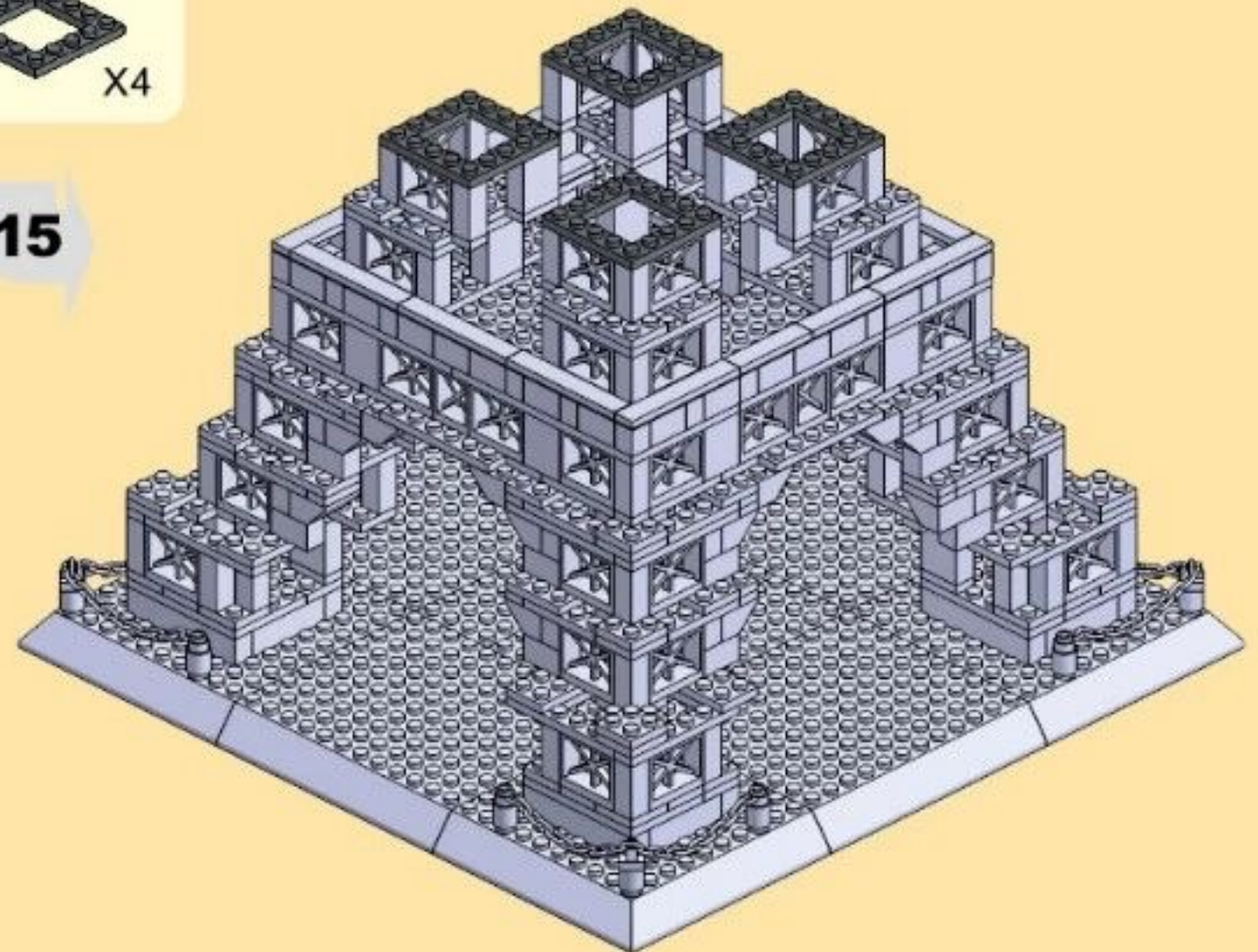

X4 X12

16

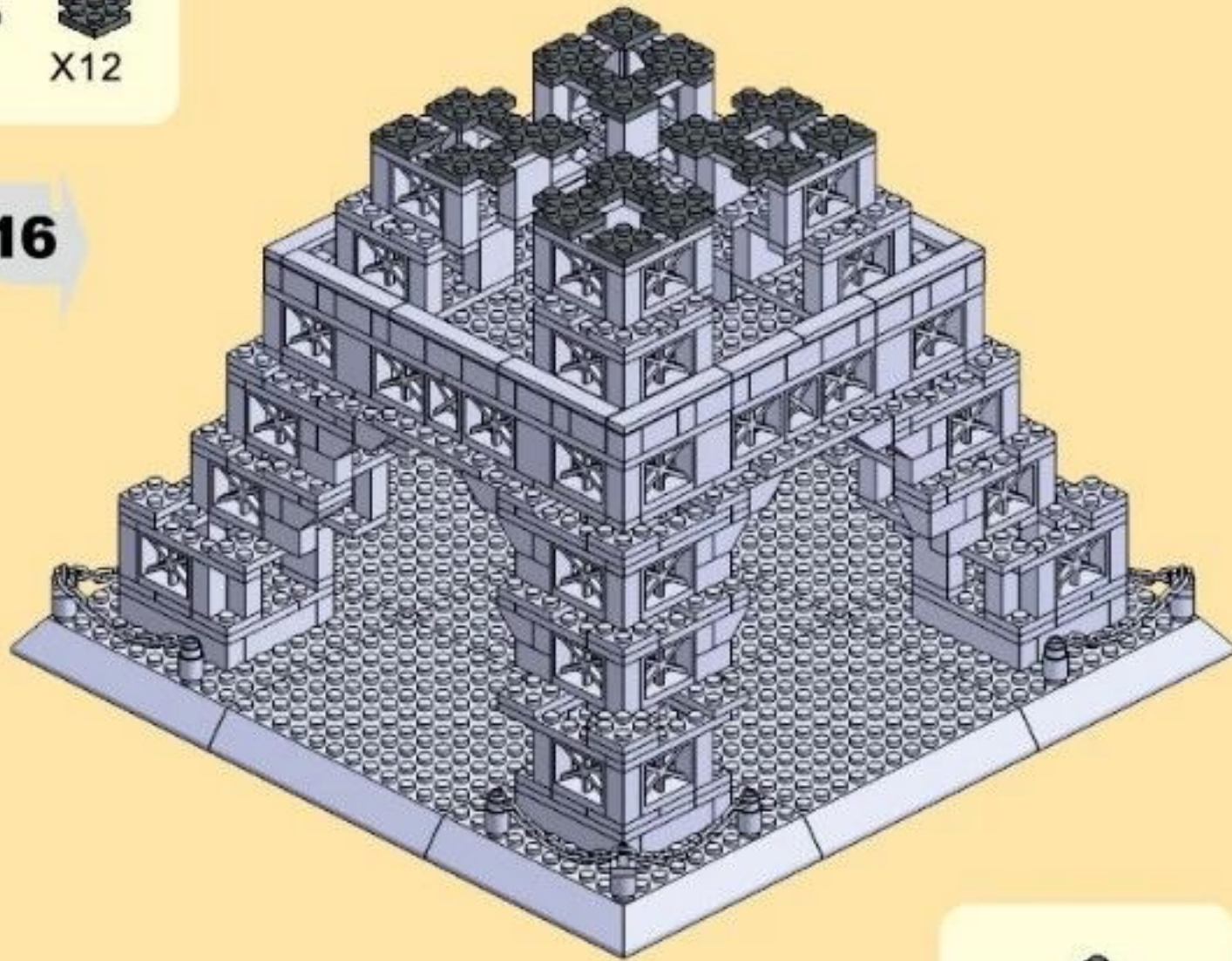

X8 X12

18



X4

17

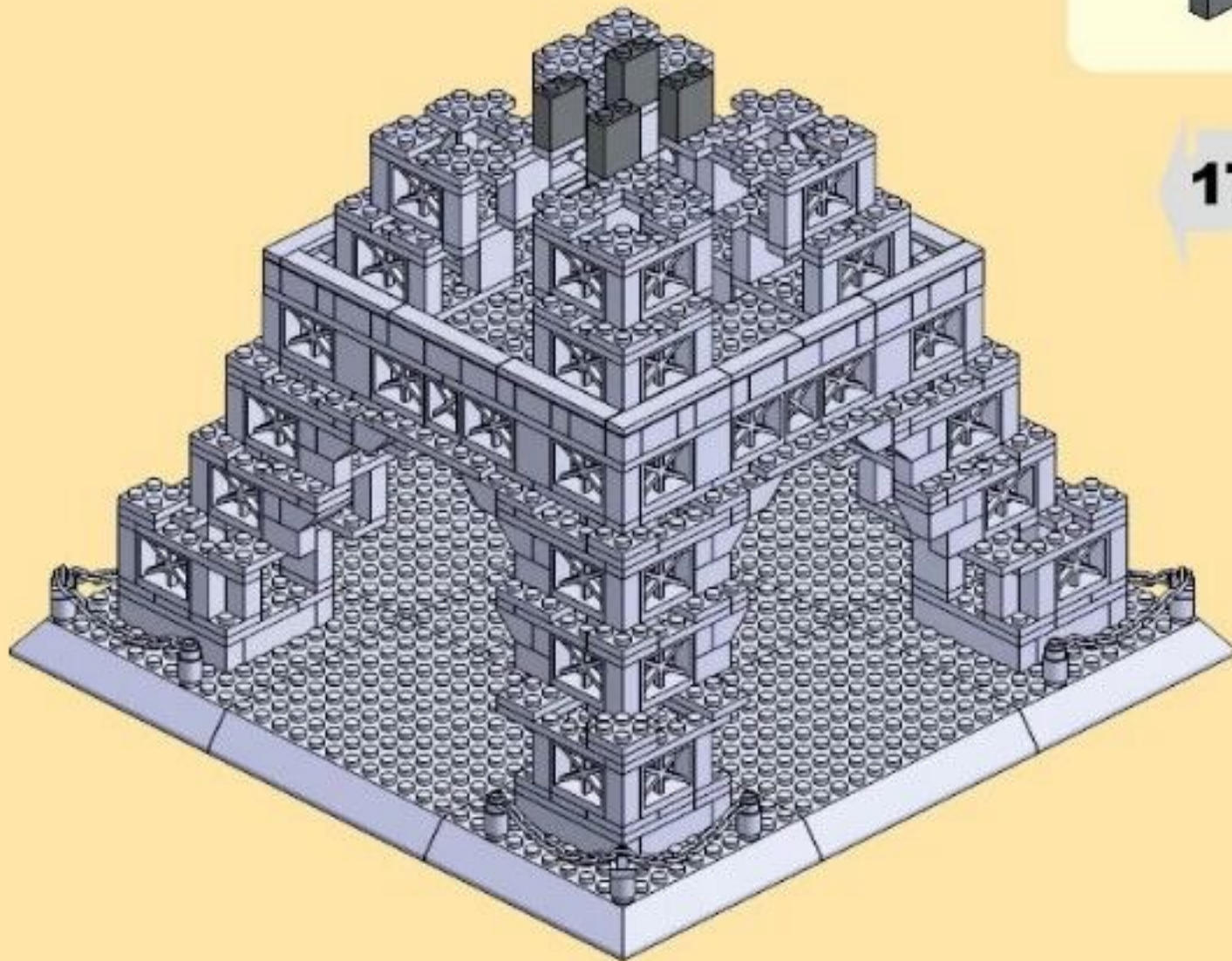

X4

19



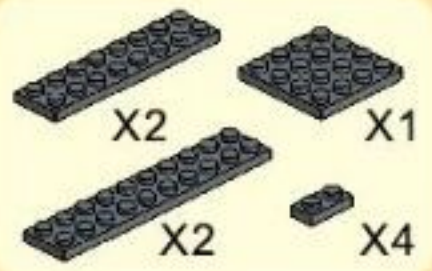

20

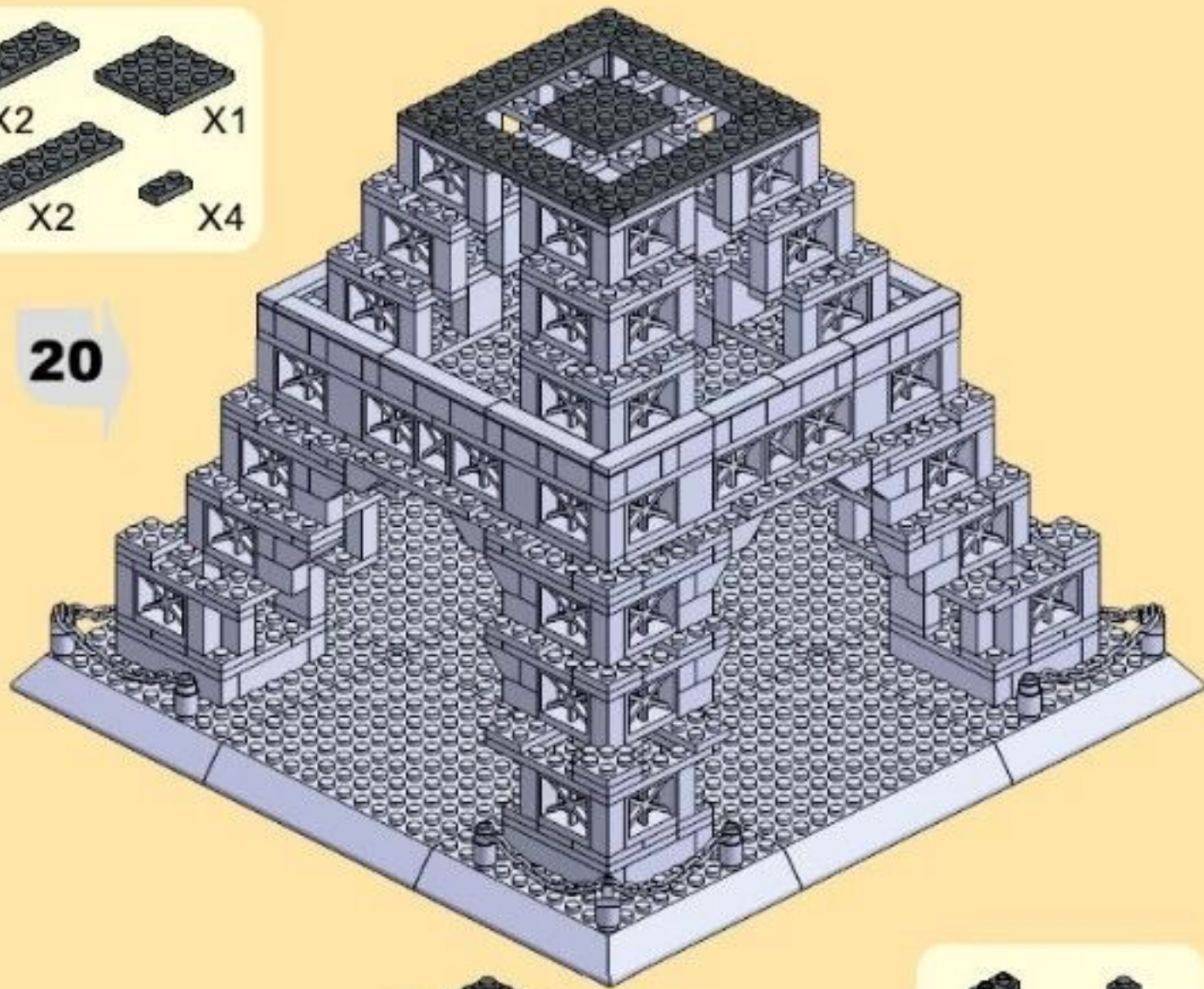

21

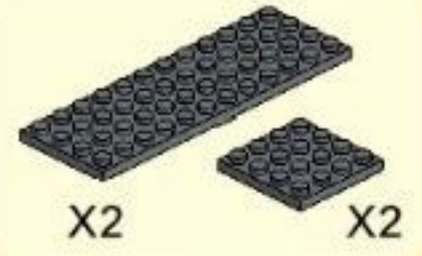
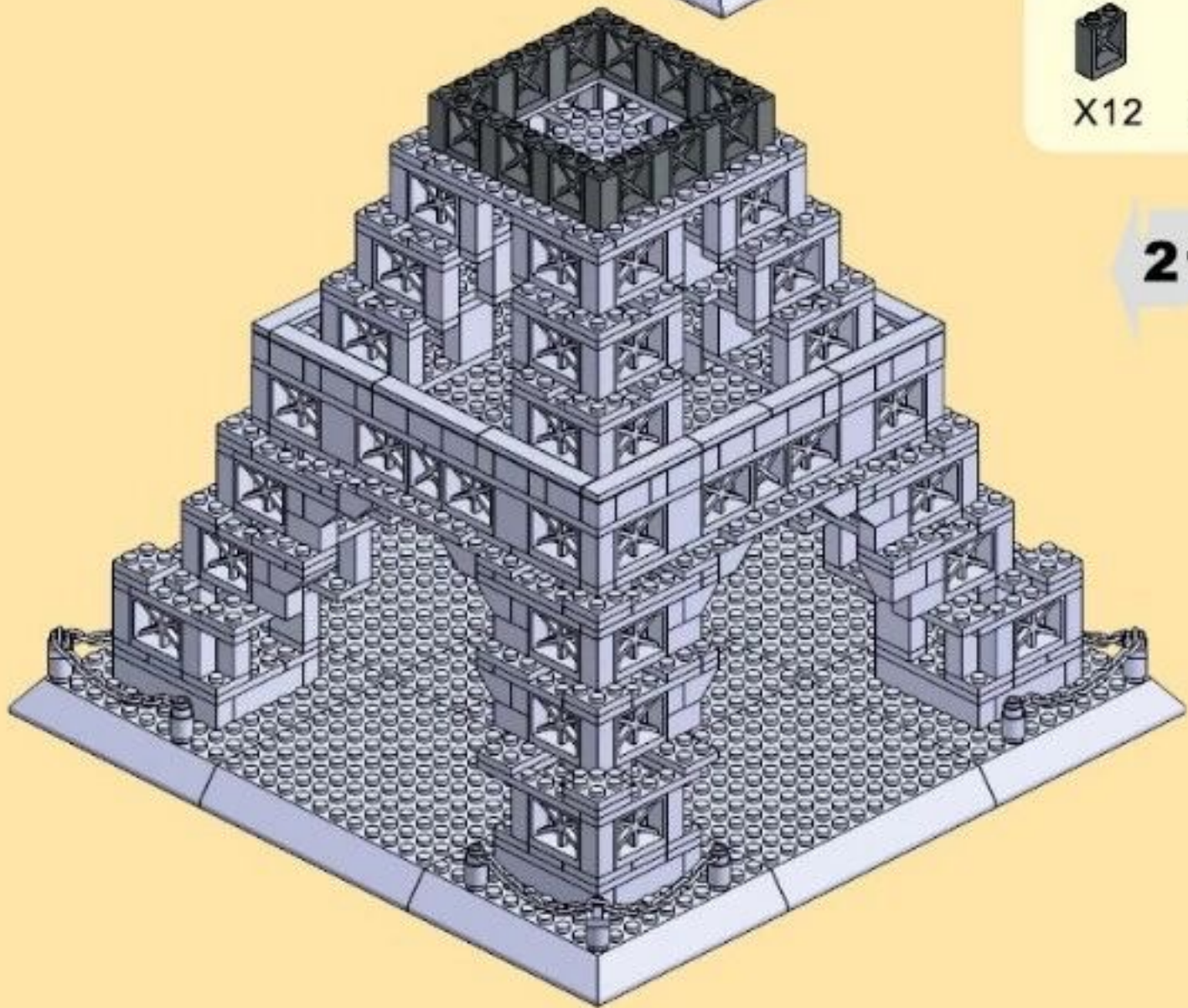

22

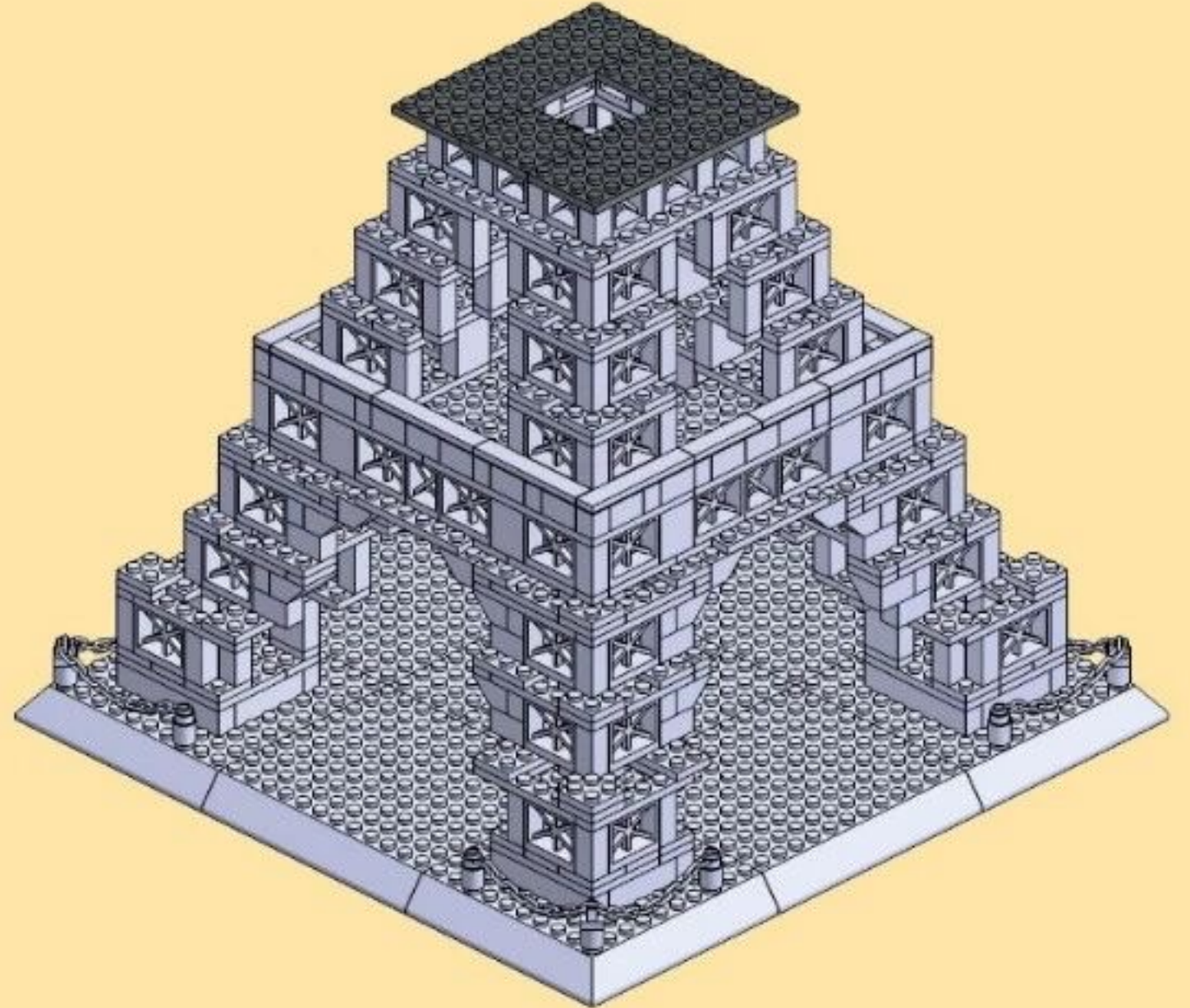

X4 X8 X4

23

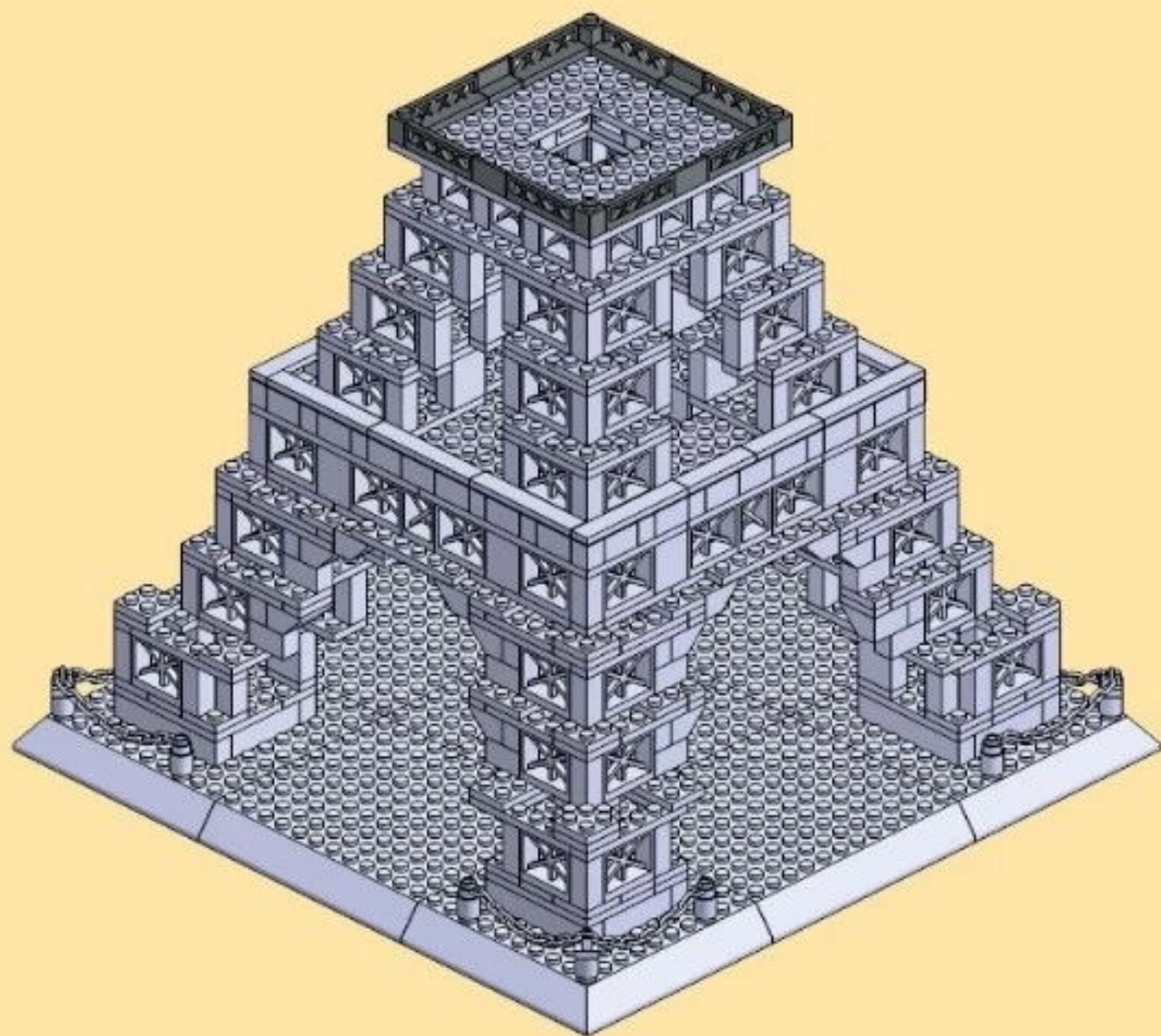

X12 X12

24

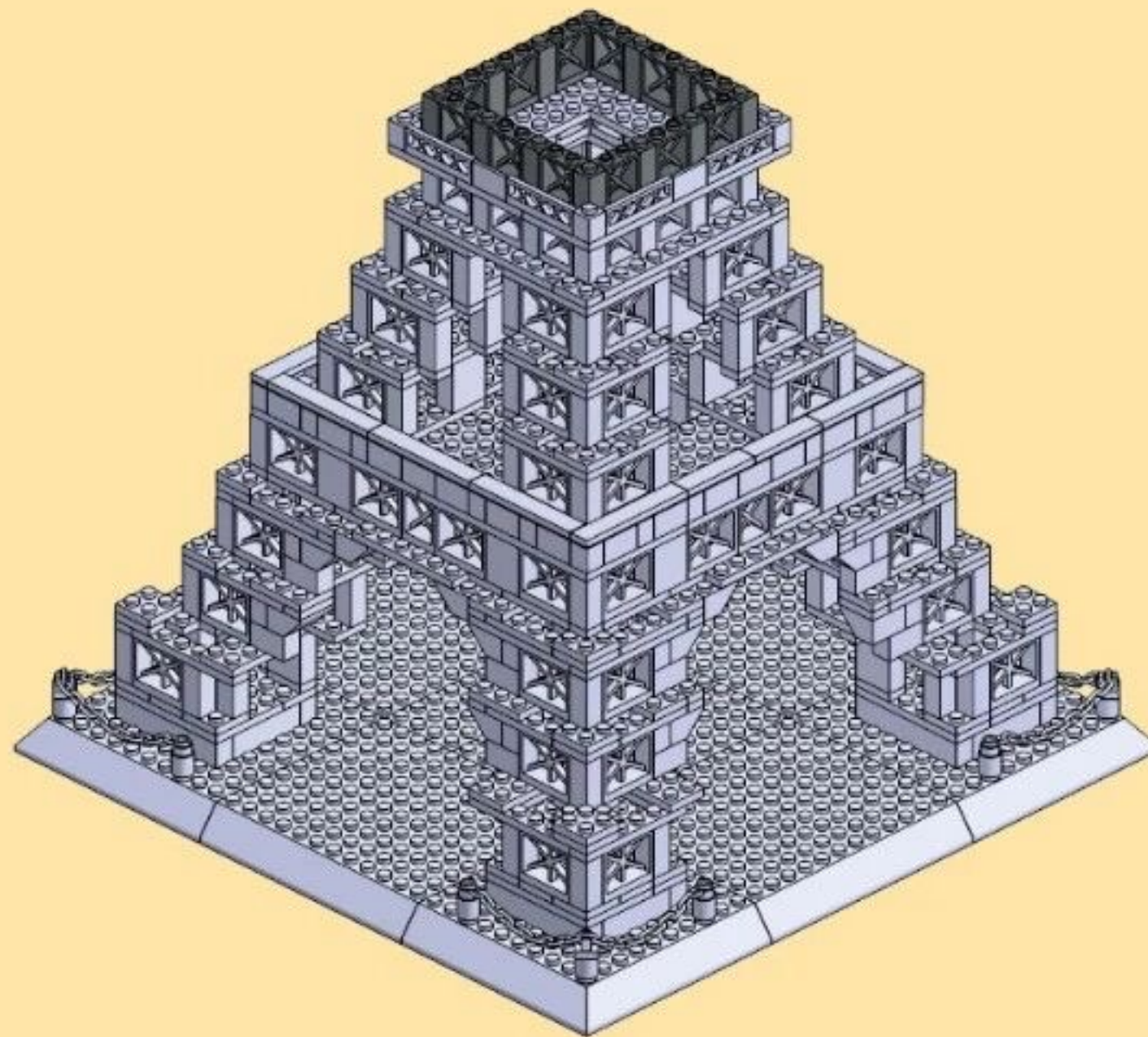

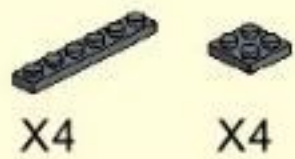

25

X4

X4

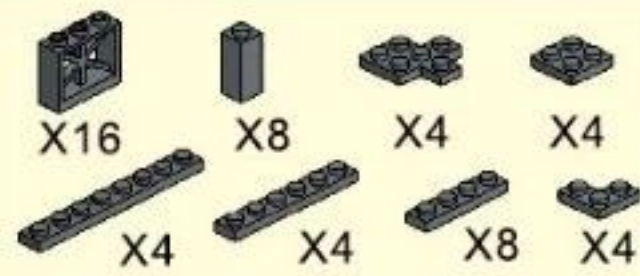
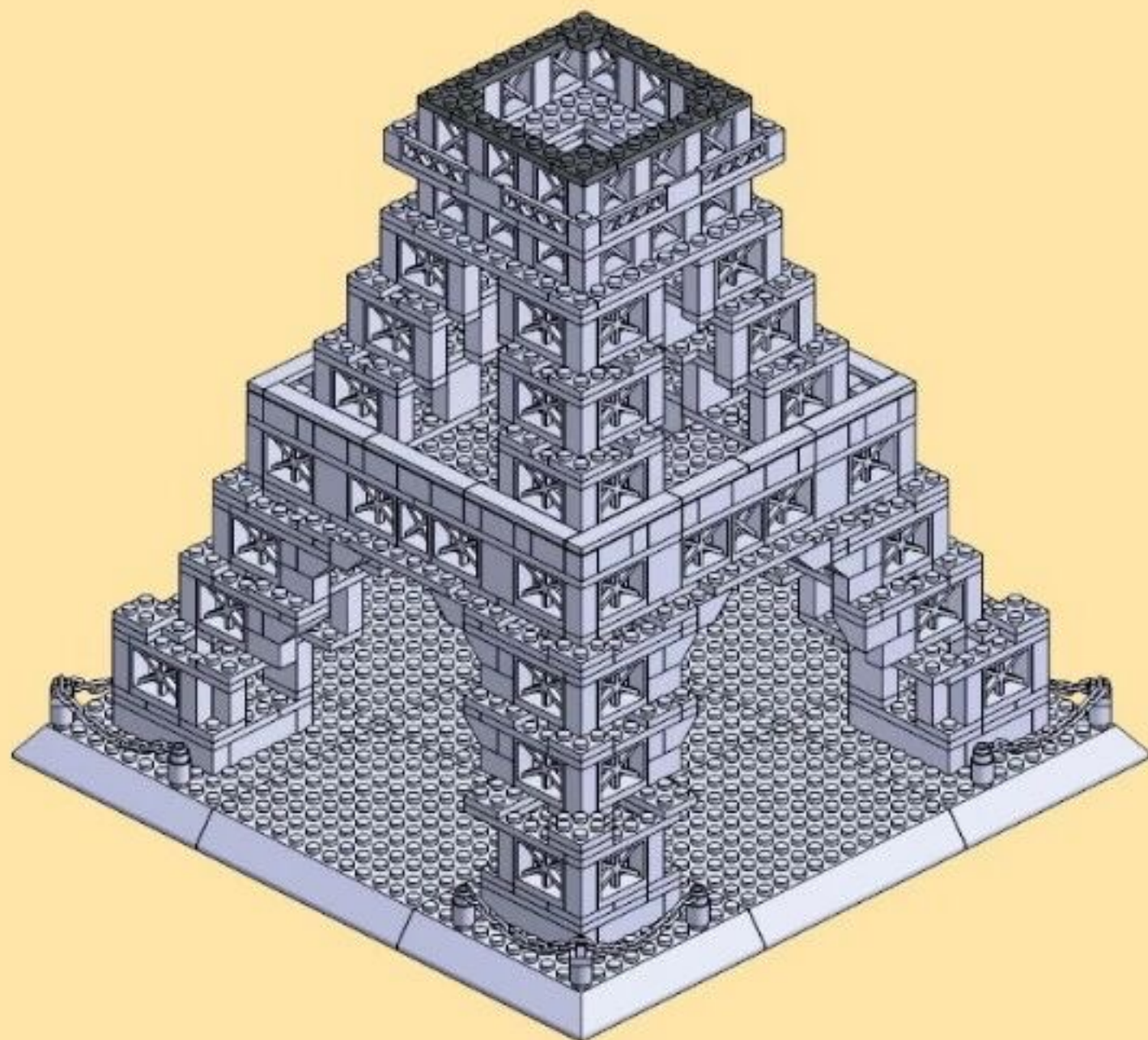

A



A1

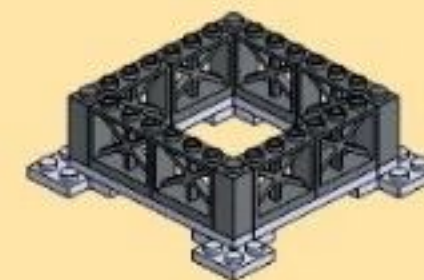

A2

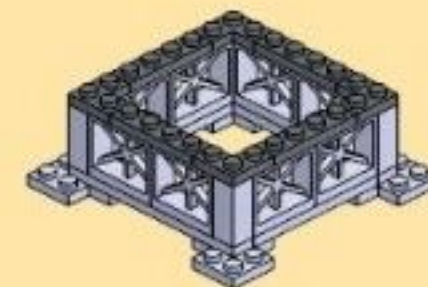

A3

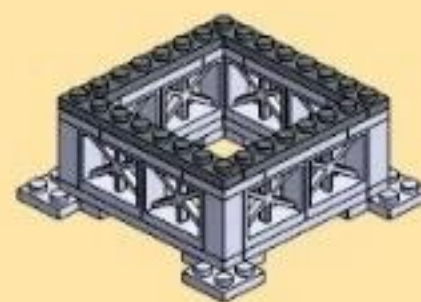

A4

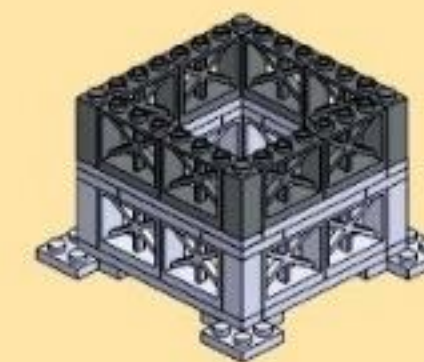

A5

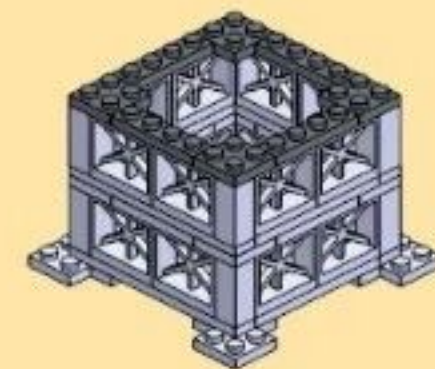

A6

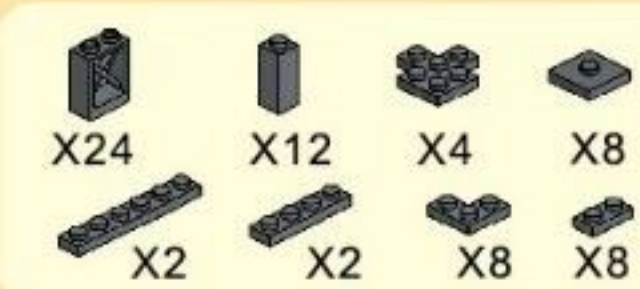

B

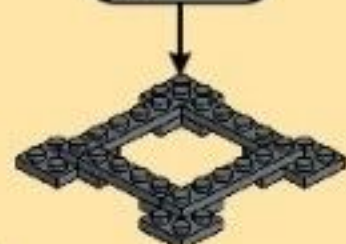

B1



B2



B3

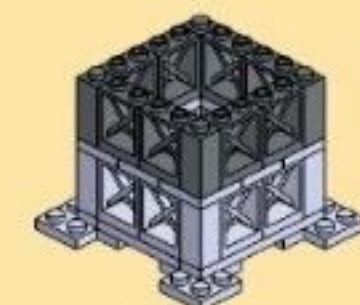

B4

11

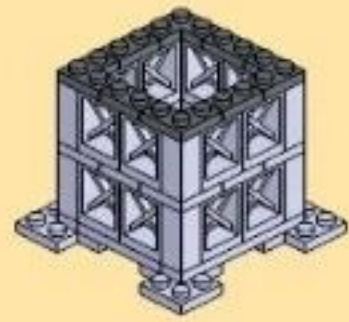

B5



B6

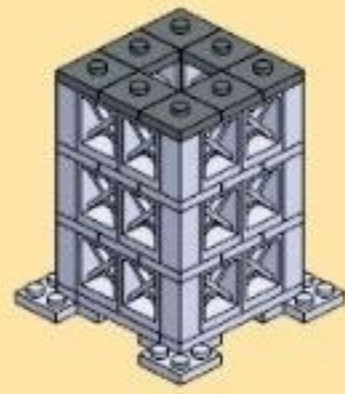

B7



C1



C



C2



C3



C4

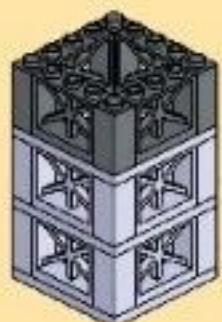

C5



C6

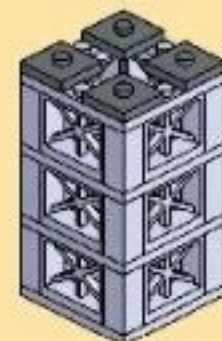

C7

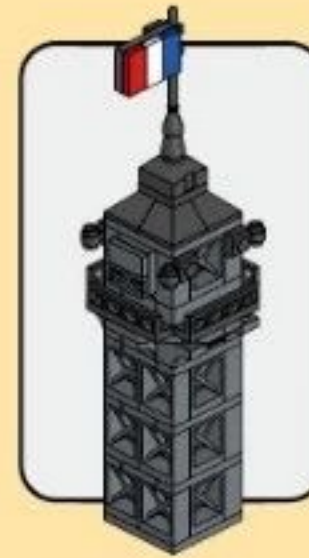

D



D1



D2



D3

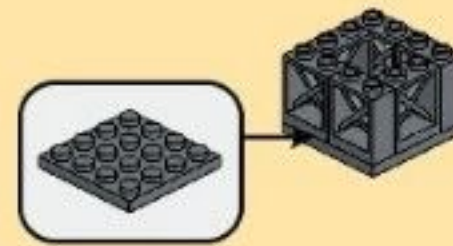

D4



D5

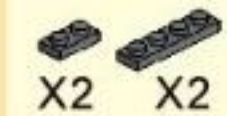

D6



D7

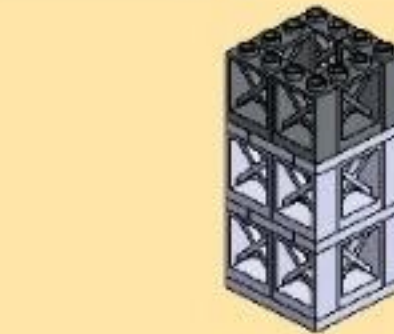

D8

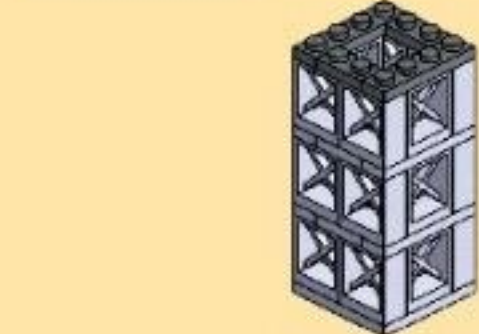

D9

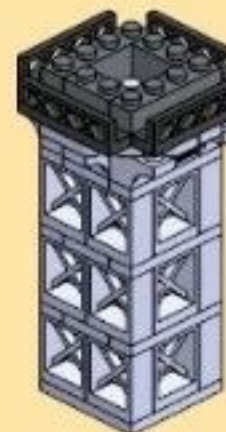
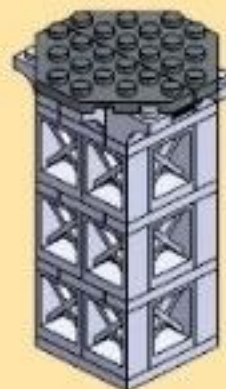
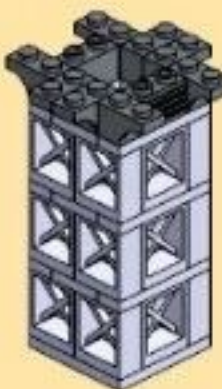



X4

D10

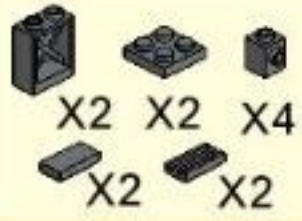
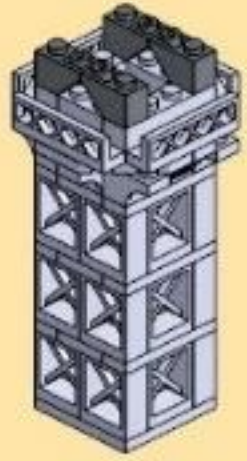

X2 X2 X4
X2 X2

D11

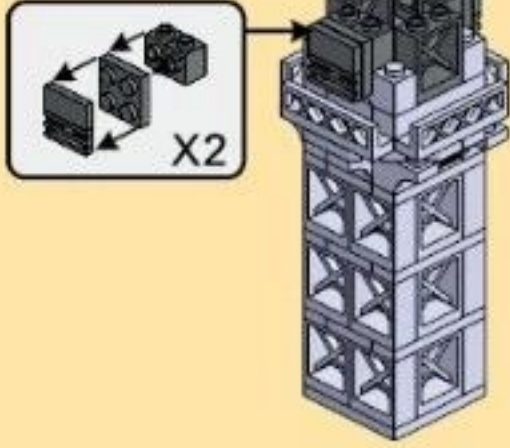

X4 X4

D12

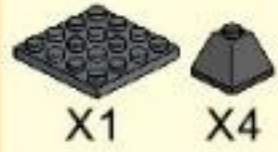
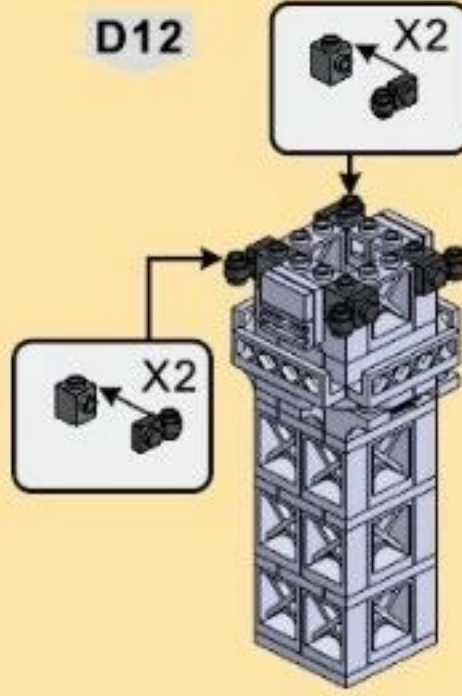

X1 X4

D13

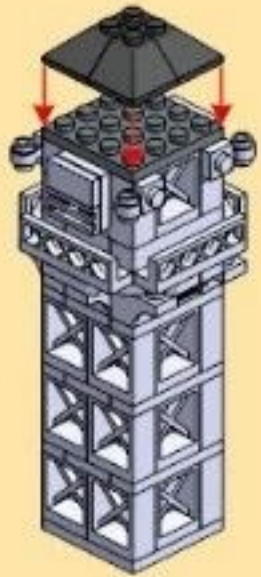

X1 X1 X1

D14



X1 X1 X2
X1 X1 X1

D15

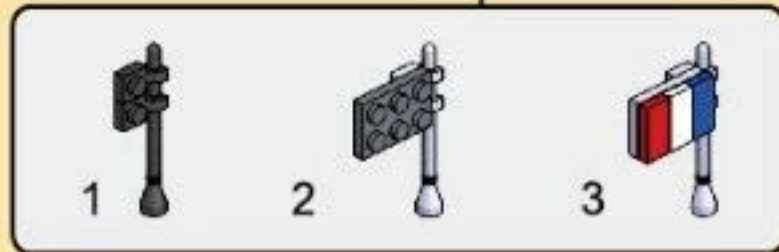
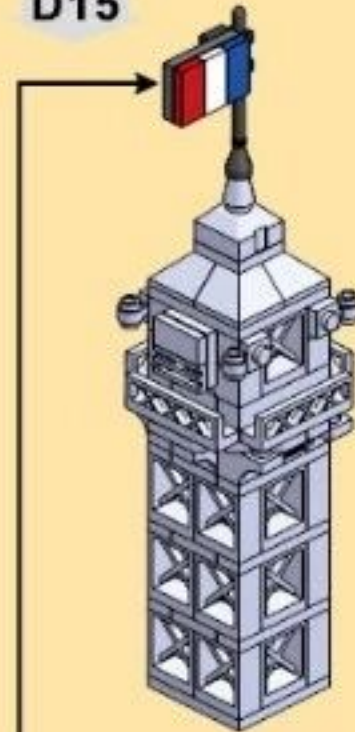

1

2

3

26

A+B+C+D

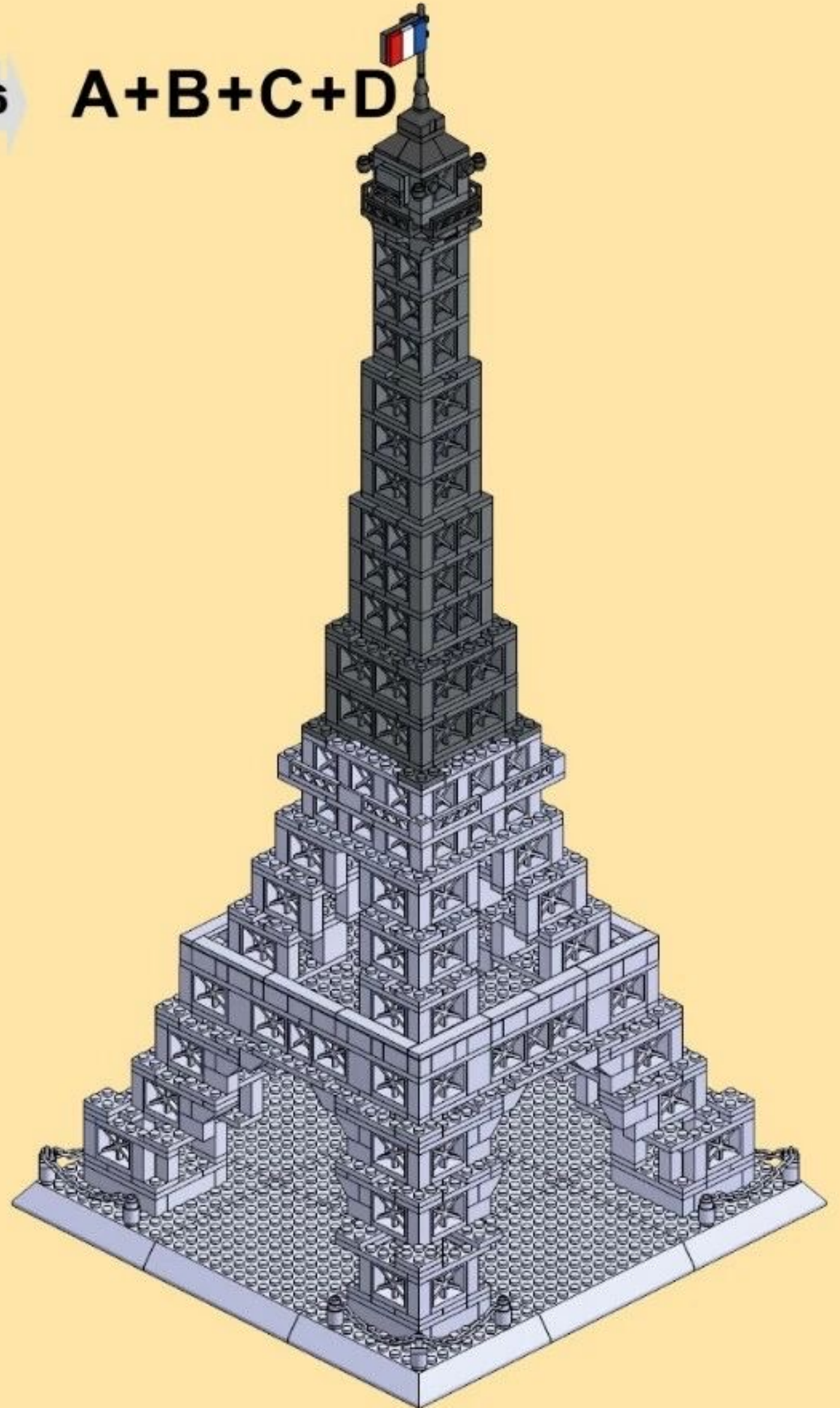

13



X1



X1

27

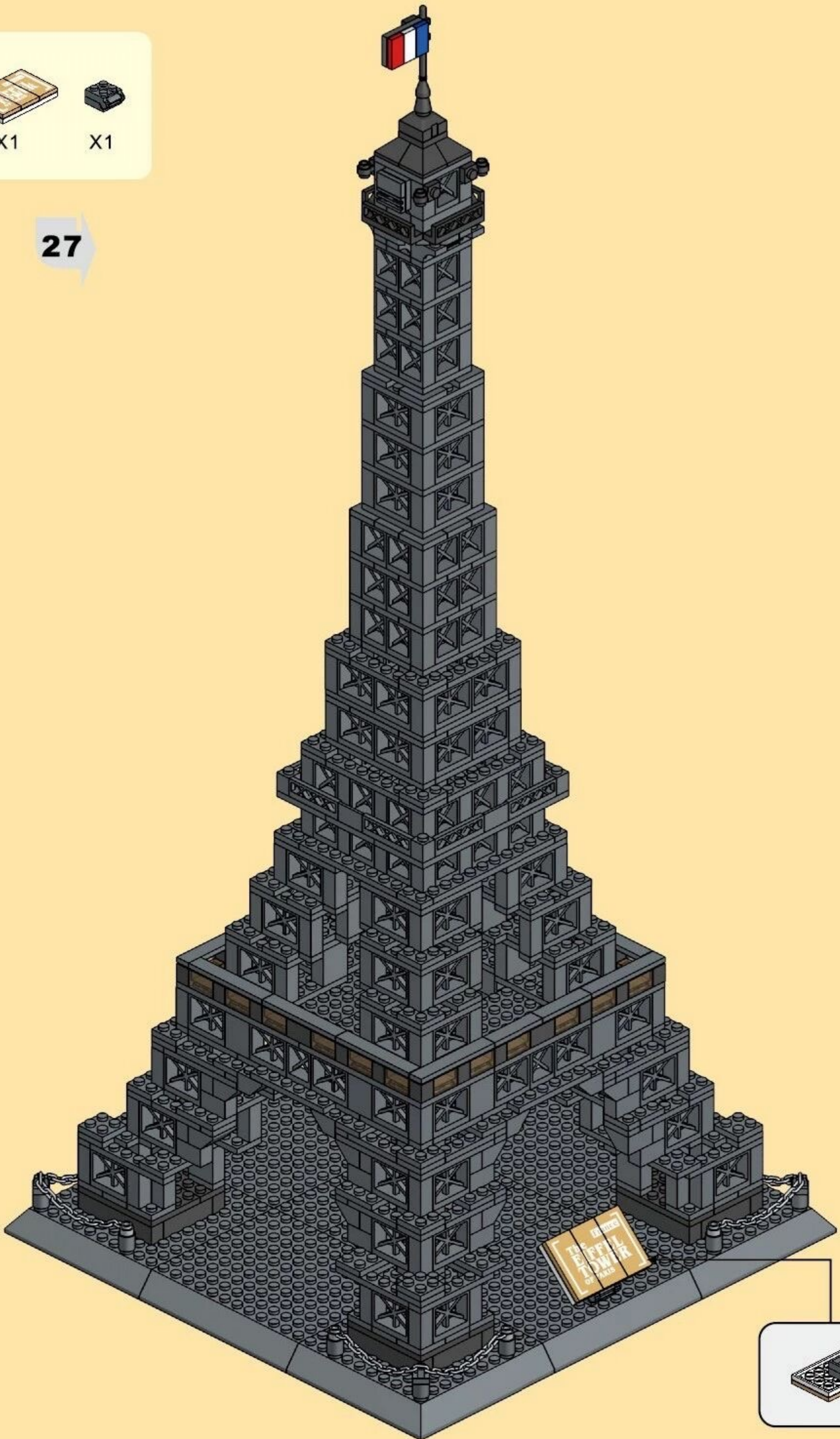



THE EIFFEL TOWER OF PARIS

INTRODUCTION

The Eiffel Tower located on the Champ de Mars in Paris, was inaugurated on 31 March 1889. It was the keystone of the Universal Exposition celebrating the hundredth anniversary of the French Revolution. Now the Eiffel Tower has become both a global icon of France and one of the most recognizable structures in the world.

The tower has three levels for visitors. The walk to the first level is over 300 steps, as is the walk from the first to the second level. The third and highest level is accessible only by elevator. The pig iron structure of the Eiffel Tower weighs 7,300 tonnes while the entire structure, including non-metal components, is approximately 10,000 tonnes.

The Tower stands 1,063 ft

[324 m] tall, about the same height as an 81-story building. Upon its completion, it surpassed the Washington Monument to assume the title of tallest man-made structure in the world, a title it held for 41 years, until the Chrysler Building in New York City was built in 1930; however, due to the addition in 1957 of the antenna, the tower is now taller than the Chrysler Building. More than 100 years after the Eiffel Tower was built, its technology, especially the lift and elevator system, remains amazing.

