



HALL OF PRAYER FOR GOOD HARVESTS

中国北京天坛祈年殿

Beijing, China

The world's great architecture

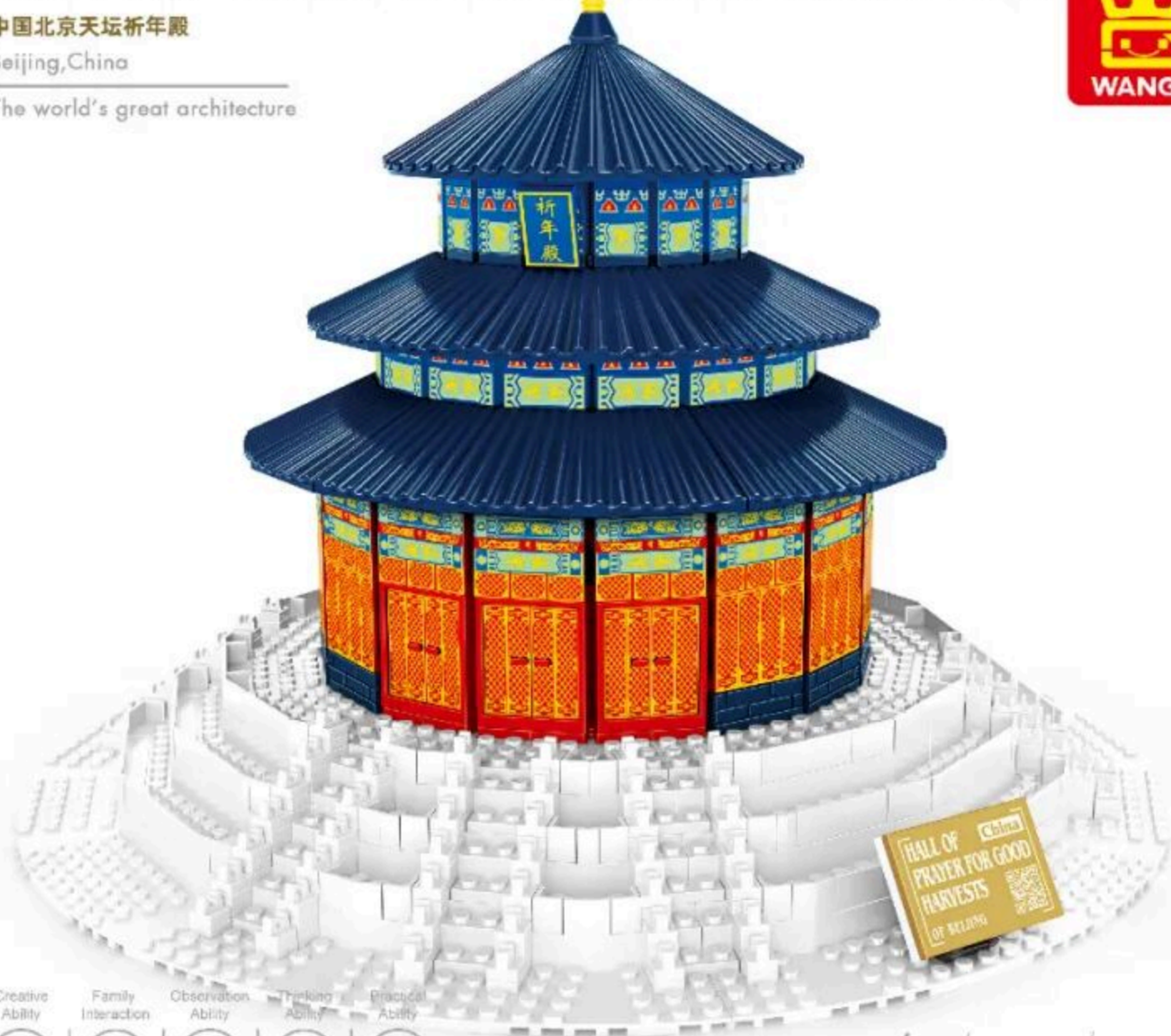

6+ / 5222 / 986 PCS
Suitable Age / Product Number / Parts Total



Architecture

It will be a city...

这将构成一座城市...

ABOUT THE PRODUCT

关于产品

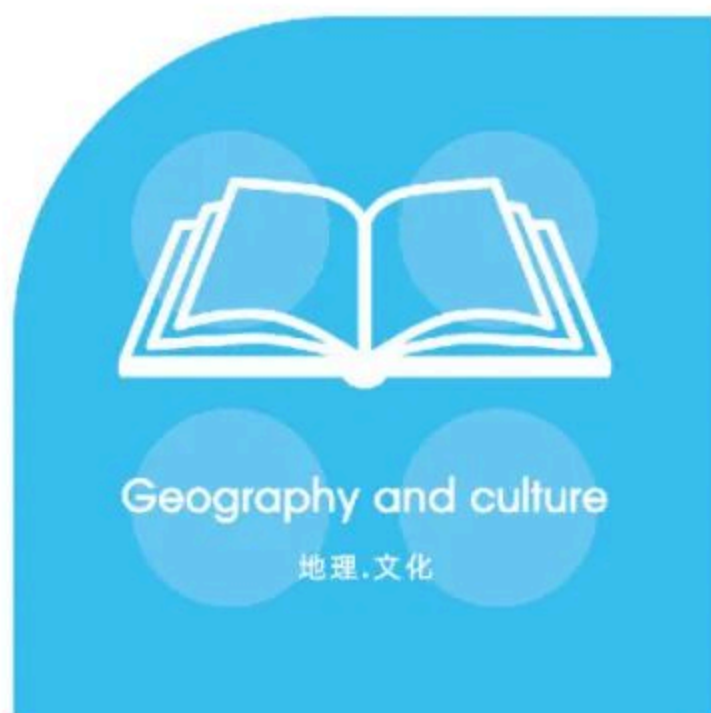

ARCHITECTURE

WANGE The world's great architect since 1991

Guangdong Baoge Educational Material Sci-Tech Co., Ltd.
©2014 Wange / Dubie. All Rights Reserved

Hall of Prayer for Good Harvests



The Temple of Heaven is an imperial complex of religious buildings situated in the southeastern part of central Beijing. The complex was visited by the Emperors of the Ming and Qing dynasties for annual ceremonies of prayer to Heaven for a good harvest.

Hall of Prayer for Good Harvests



Geography and culture

地理·文化



The temple complex was constructed from 1406 to 1420 during the reign of the Yongle Emperor of Ming Dynasty. Panorama with the Hall of Prayer for Good Harvests in the center, viewed from the south.



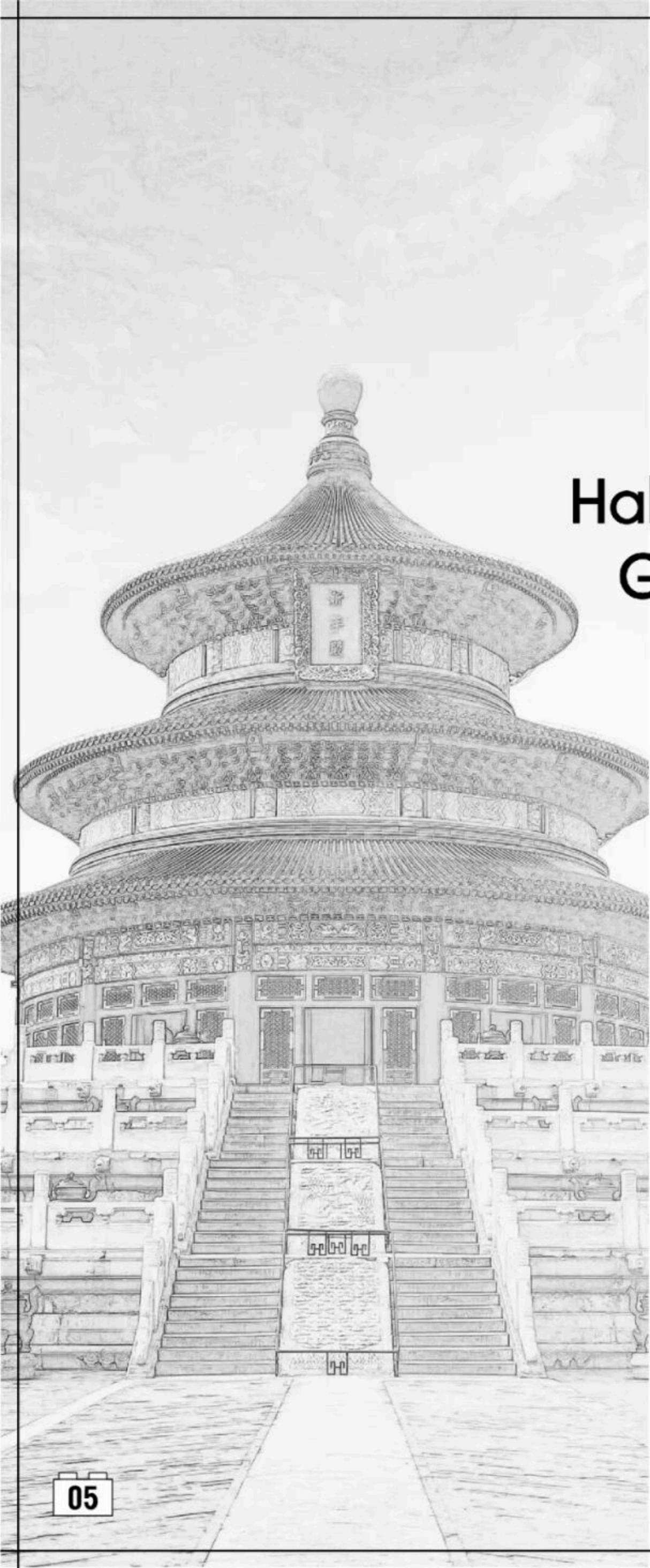

中国北京天坛-祈年殿

Hall of Prayer for Good Harvests

China

The contents of this chapter refer to the Wikipedia website.

本章内容参考维基百科网站，
更多资讯可自行查阅。

The world's great architecture

Buildings and layout

■ 建筑物和布局



祈年殿是天坛的主体建筑，始建于明·永乐十八年（1420年），原名大祈殿，在天坛的北部，位于祈谷坛中央，又称祈谷殿，清·乾隆十六年（1751），改三色瓦为统一的蓝瓦金顶，定名“祈年殿”，是明清两代皇帝孟春祈谷之所。它是一座鎏金宝顶、蓝瓦红柱、金碧辉煌的彩绘三层重檐圆形大殿。祈年殿采用的是上殿下屋的构造形式。大殿建于高6米的白石雕栏环绕的三层汉白玉圆台上，即为祈谷坛。颇有拔地擎天之势，壮观恢弘。祈年殿为砖木结构，殿高38米，直径32米，三层重檐向上逐层收缩作伞状。建筑独特，无大梁长檩及铁钉，二十八根楠木巨柱环绕排列，支撑着殿顶的重量。祈年殿是按照“敬天礼神”的思想设计的，殿为圆形，象征天圆；瓦为蓝色，象征蓝天。

The Hall of Prayer for Good Harvests (祈年殿) is a magnificent triple-gabled circular building, 36 m (118 ft) in diameter and 38 m (125 ft) tall, built on three levels of marble stone base, where the Emperor prayed for good harvests. The building is completely wooden, with no nails. The original building was burned down by a fire caused by lightning in 1889. The current building was re-built several years after the incident.

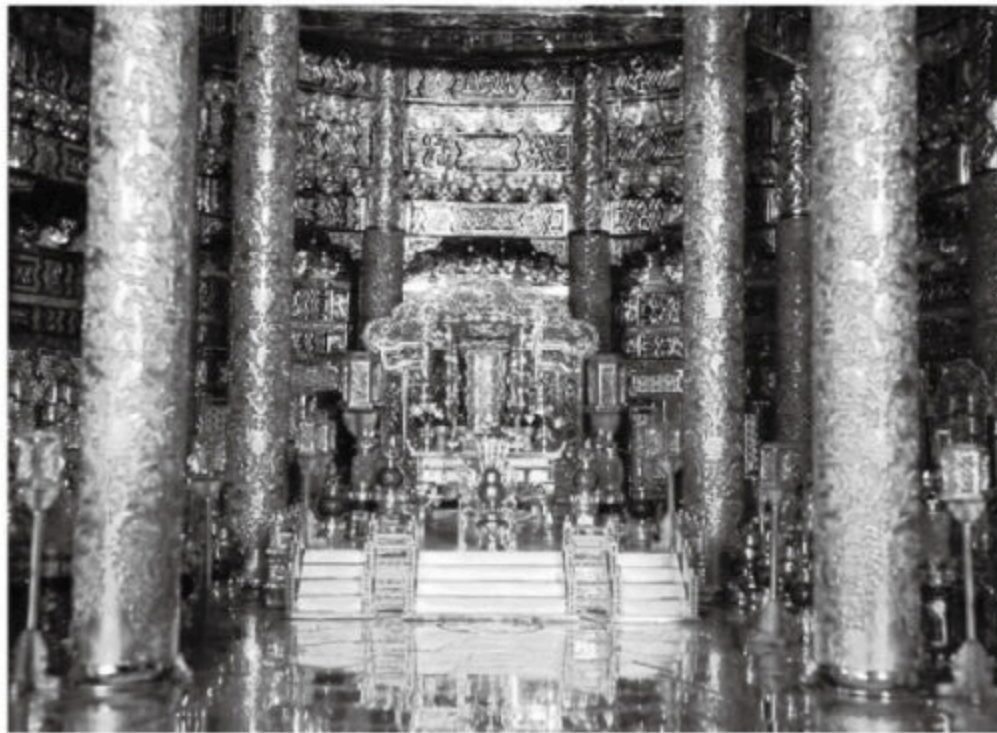

Symbolism

祈年殿的内部结构比较独特，不用大梁和长檩，仅用沉香木柱和枋栿相互衔接支撑屋顶。光绪年间重建后殿内有楠木柱二十八根，数目排列切合天象：中央4根龙柱高19.2米、直径1.2米，象征四季，中圈12根金柱象征一年十二个月，外层12根巨柱象征一天十二个时辰，中层和外层相加象征二十四节气，三层柱总共28根象征二十八宿。殿内地板的正中是一块圆形大理石，带有天然的龙凤花纹，与殿顶的蟠龙藻井和四周彩绘金描的龙凤和玺图案相互呼应，使整座殿堂显得十分富丽堂皇。

The Hall of Prayer for Good Harvests has four inner, twelve middle and twelve outer pillars, representing the four seasons, twelve months and twelve traditional Chinese hours respectively. Combined together, the twelve middle and twelve outer pillars represent the traditional solar terms. All the buildings within the Temple have special dark blue roof tiles, representing the Heaven. The Seven-Star Stone Group, east of the Hall of Prayer for Good Harvest, represents the seven peaks of Taishan Mountain, a place of Heaven worship in classical China.



Design and construction

天坛建筑的主要设计思想就是要突出天空的辽阔高远，以表现“天”的至高无上。在布局方面，内坛位于外坛的南北中轴线以东，而圜丘坛和祈年坛又位于内坛中轴线的东面，这些都是为了增加西侧的空旷程度，使人们从西边的正门进入天坛后，就能获得开阔的视野，以感受到上天的伟大和自身的渺小。就单体建筑来说，祈年殿和皇穹宇都使用了圆形攒尖顶，它们外部的台基和屋檐层层收缩上举，也体现出一种与天接近的感觉。天坛还处处展示着中国传统文化所特有的寓意、象征的表现手法。北圆南方的坛墙和圆形建筑搭配方形外墙的设计，都寓意着传统的“天圆地方”的宇宙观。而主要建筑上广泛地使用蓝色琉璃瓦，以及圜丘坛重视“阳数”、祈年殿按天象列柱等设计，也是这种表现手法的具体体现。

Inside the Hall of Prayer for Good Harvests. Earth was represented by a square and Heaven by a circle; several features of the temple complex symbolize the connection of Heaven and Earth, of circle and square. The whole temple complex is surrounded by two cordons of walls; the outer wall has a taller, semi-circular northern end, representing Heaven, and a shorter, rectangular southern end, representing the Earth. Both the Hall of Prayer for Good Harvests and the Circular Mound Altar are round, each standing on a square yard, again representing Heaven and Earth. The number nine represents the Emperor and is evident in the design of the Circular Mound Altar: a single round marmor plate is surrounded by a ring of nine plates, then a ring of 18 plates, and so on for a total of nine surrounding rings, the outermost having 9×9 plates.

Drawing Design

手绘设计



Force Balance

受力平衡

Physical operations

物理运算

$$F = G \frac{m_1 m_2}{d^2}$$

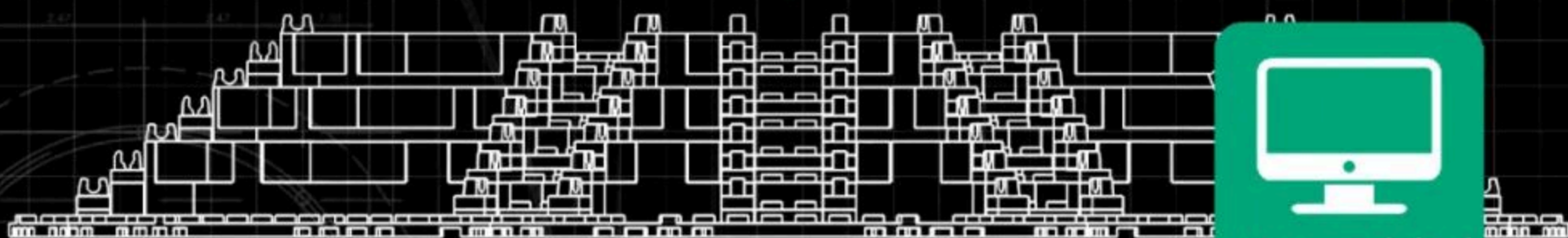
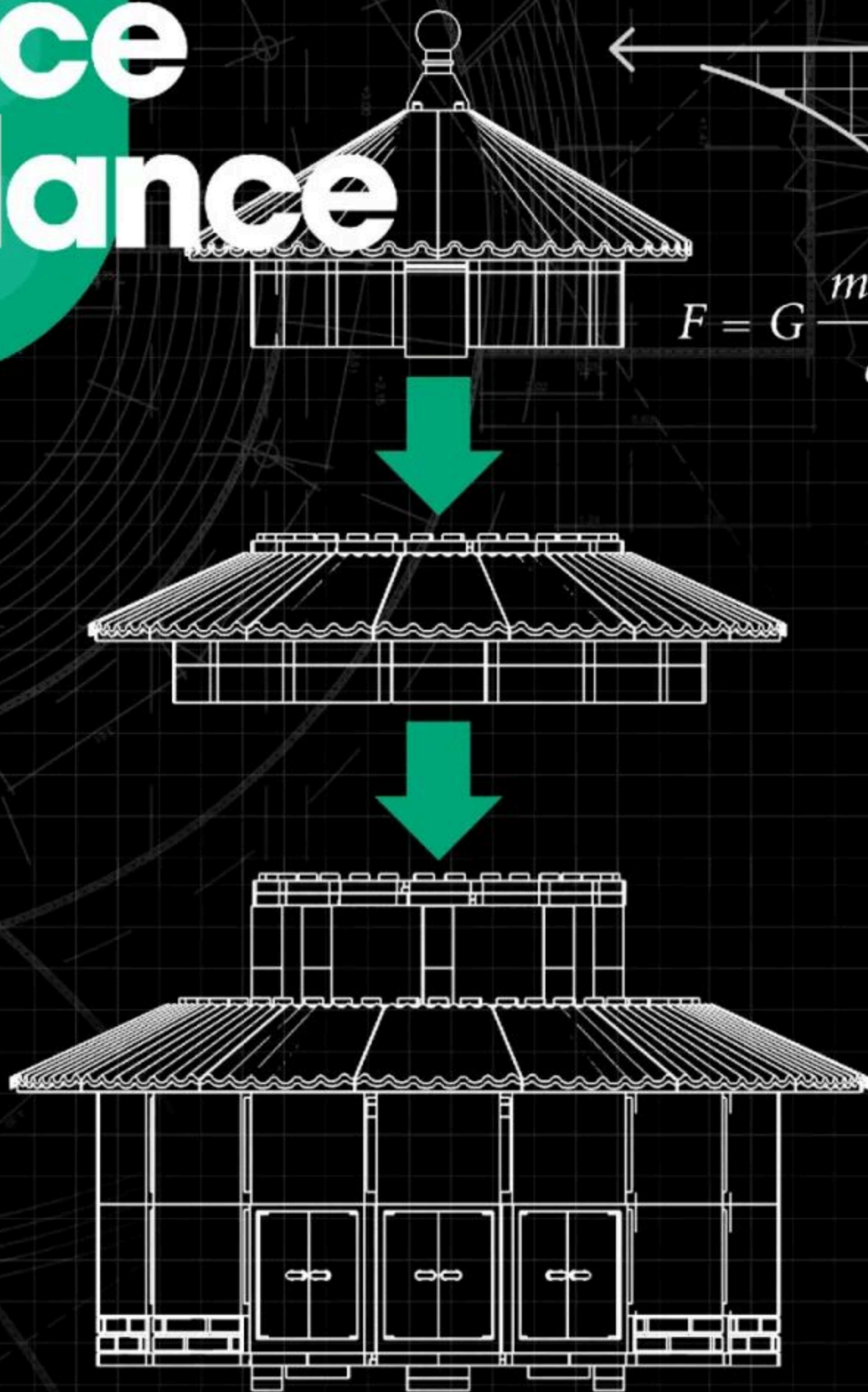

Creation and thinking

创作·思考

Special parts

特殊零件的开发利用



WG1280
4孔墙砖



WG0586
圆瓦片1孔



WG0588
圆瓦片3孔



WG0587
圆瓦片2孔

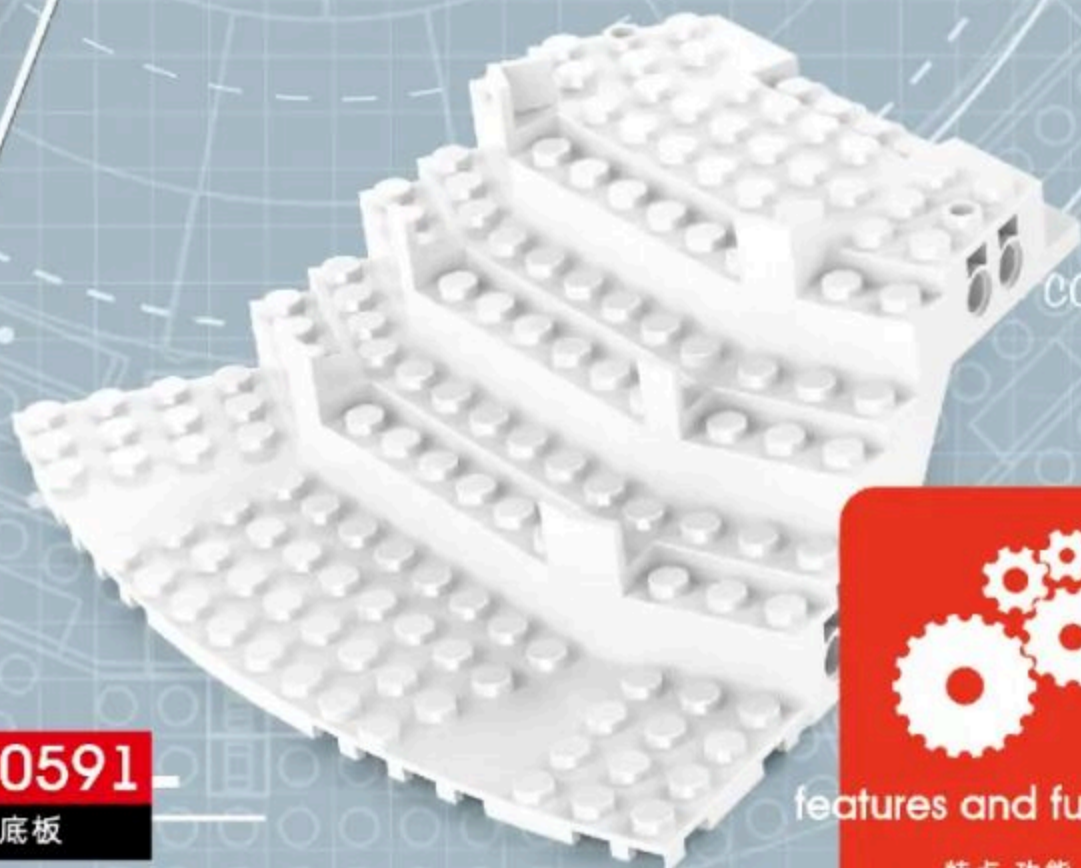

WG0591
圆底板

$$S=4\pi \cdot r^2$$

$$a^2+b^2=c^2$$

$$\cos^2 a=1$$



features and function

特点.功能

Main Color Matching

配色方案



Pantone Black 6C



Pantone 431C



Pantone 655C



Pantone 285C



Pantone 7509C



Pantone 123C



Pantone 7620C

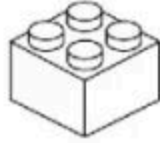

Pantone 4625C

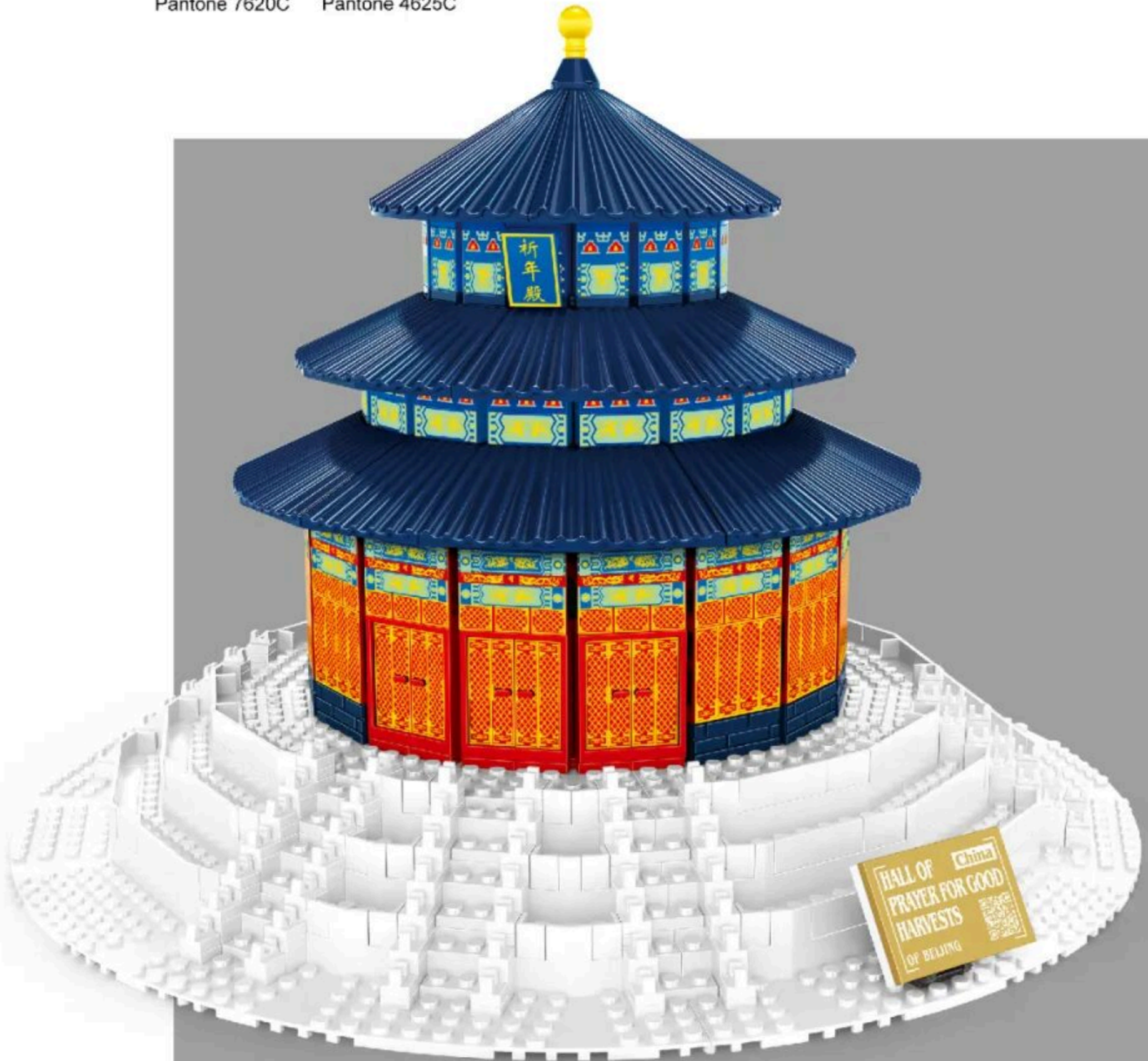

Color matching

Adopting 5 main colors, White, Blue, Prussian Blue, Yellow and Red as the main color, the more reasonable and bold color matching on the original building, making the product more atmospheric and the whole design is more reasonable.

Hall of Prayer for Good Harvests

中国北京天坛-祈年殿

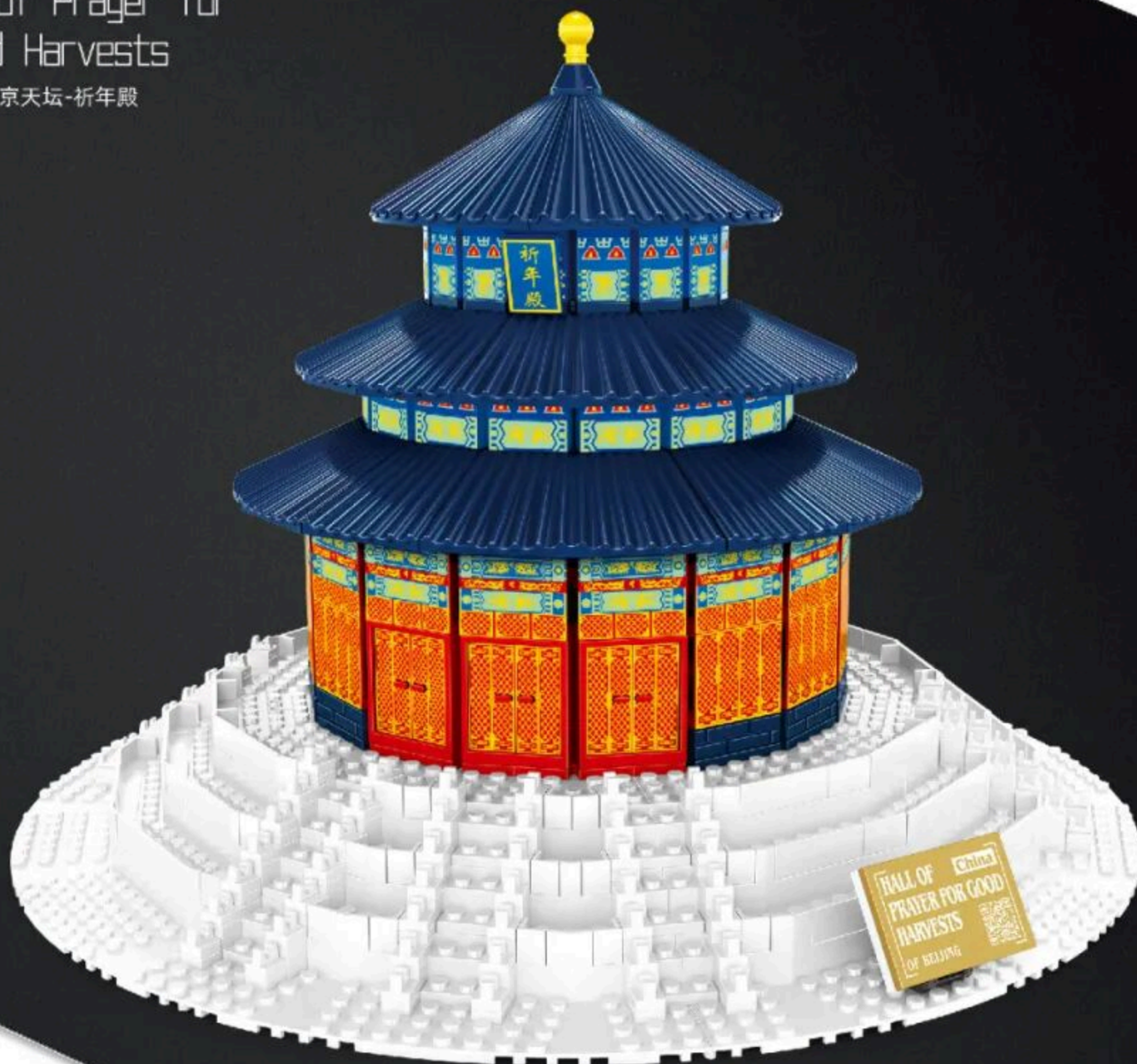

Front

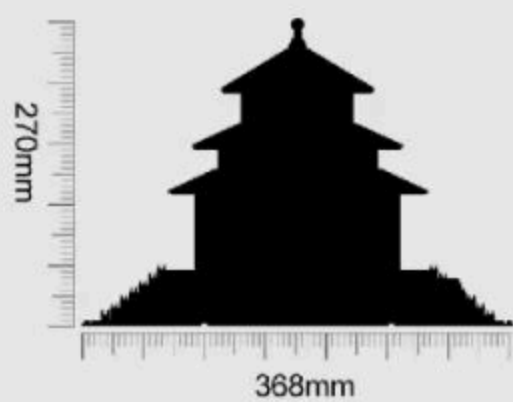

Left

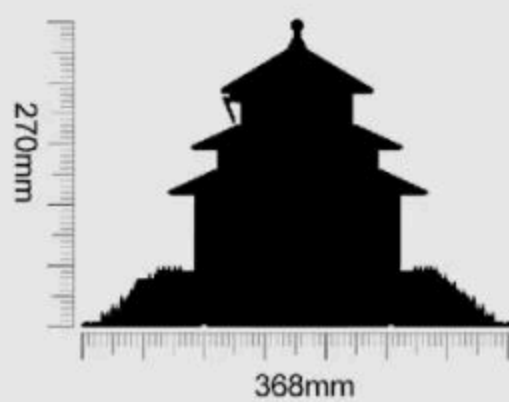

Back

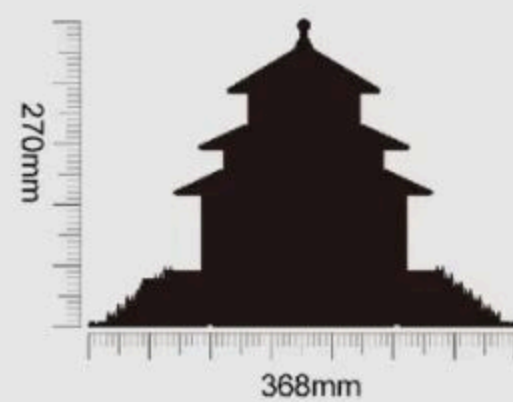

Product Size:368X368x270mm



Instructions For Use

积木起件器使用说明
Brickseparator

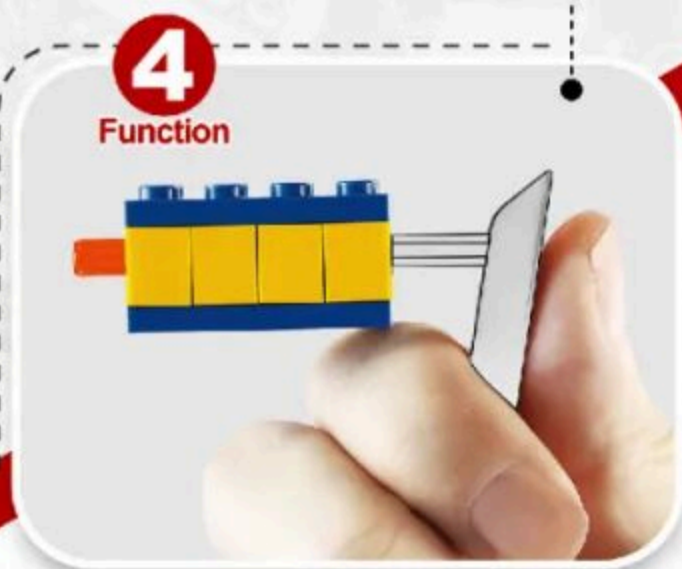
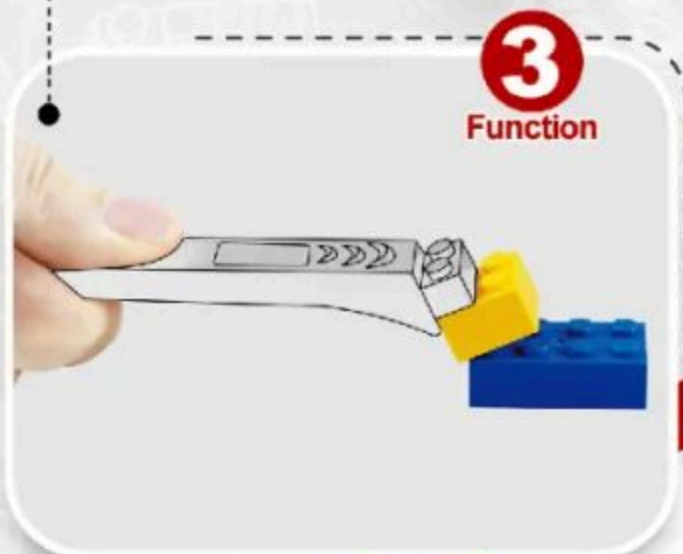
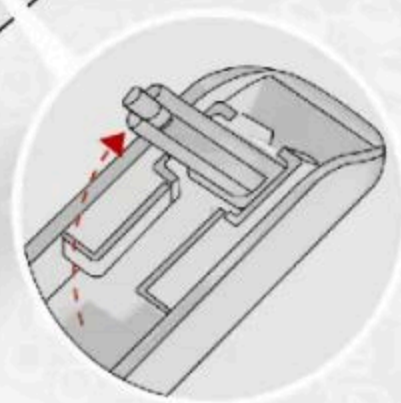
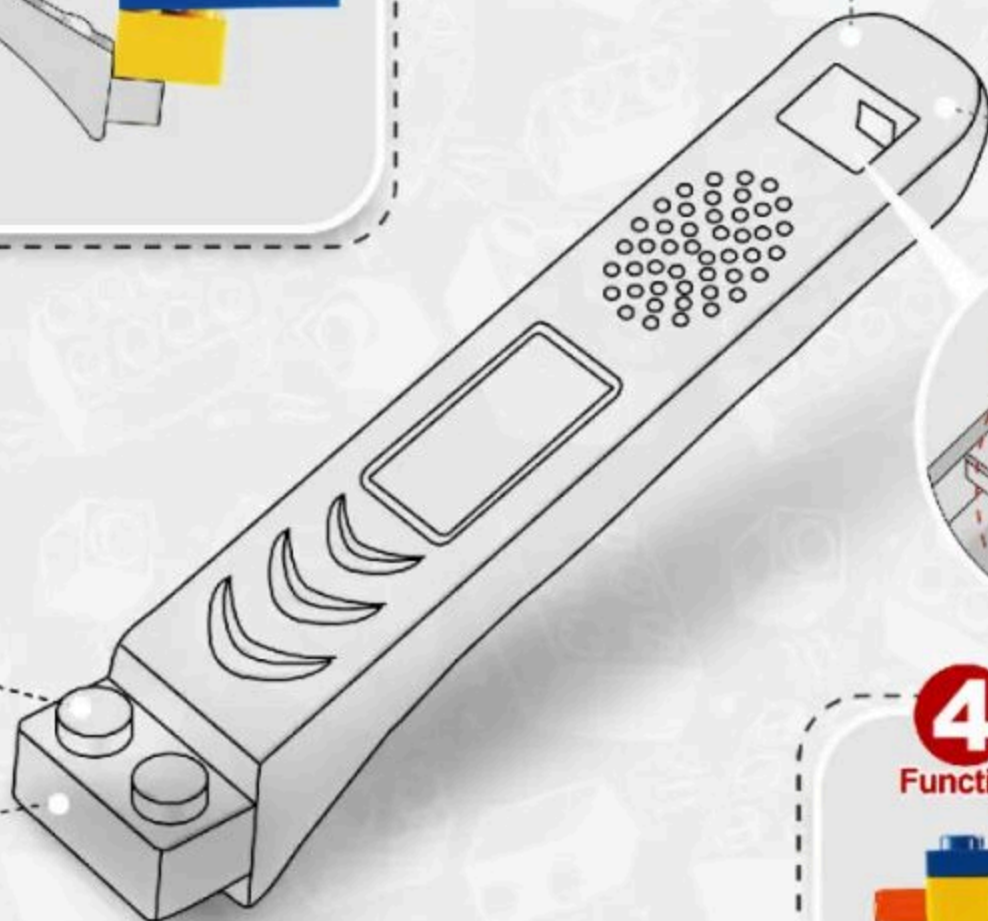
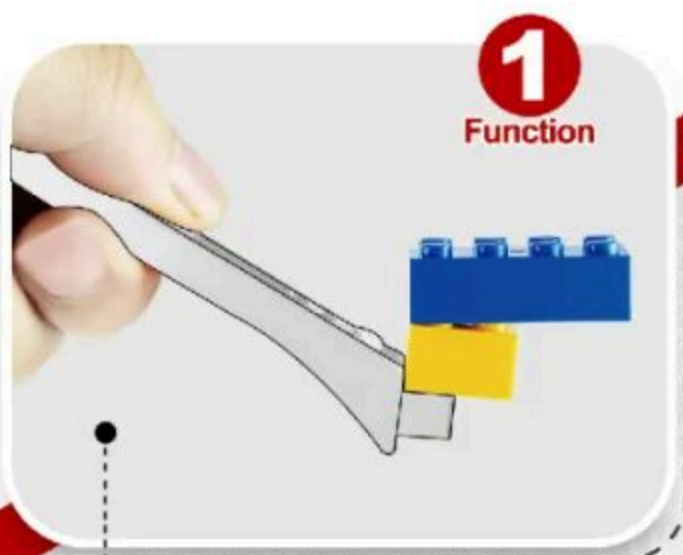

4 ways to make installation easier
让安装更简单



■ First open the product packaging according to the instructions.

按指导用正确方式拆解产品外包装。



■ Summarize all parts to count the number of familiar accessories.

对照说明书清单确认积木包数量与积木数量。



■ Arranging all accessories by color helps to quickly install the product.

把确认好的积木以类型、颜色进行分类排好以便安装。



■ Carefully install the product and learn about building.

按说明书步骤拼装并完成你的积木模型。



1:1 Physical Reference Table

十字棒配件1:1尺寸参照表



Instructions For Use

让安装更简单



2 (1x2)=2



3 (1x3)=3



4 (1x4)=4



5 (1x5)=5



6 (1x6)=6



7 (1x7)=7



8 (1x8)=8



9 (1x9)=9



10 (1x10)=10



12 (1x12)=12



16 (1x16)=16





170PCS

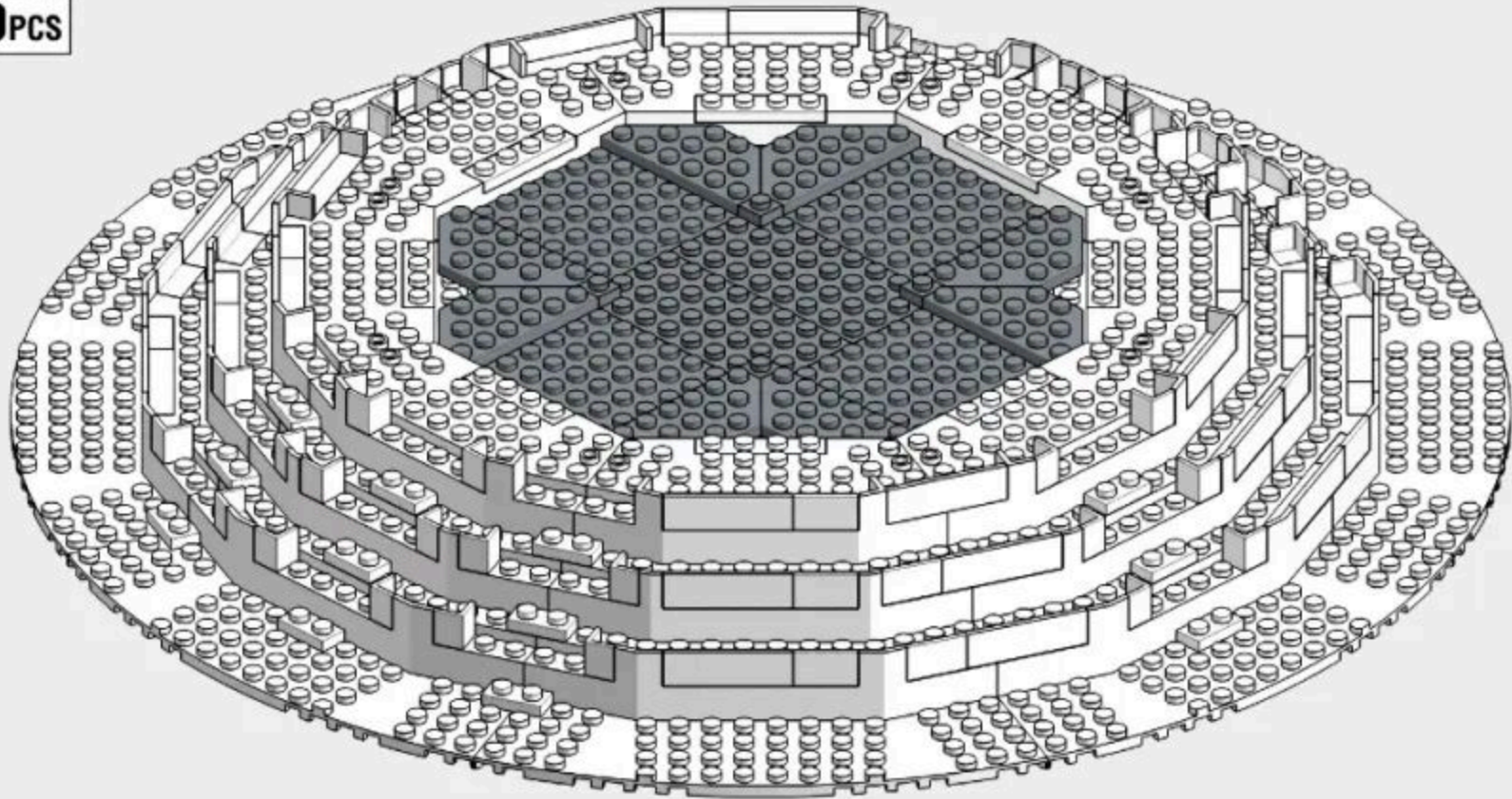

1-1

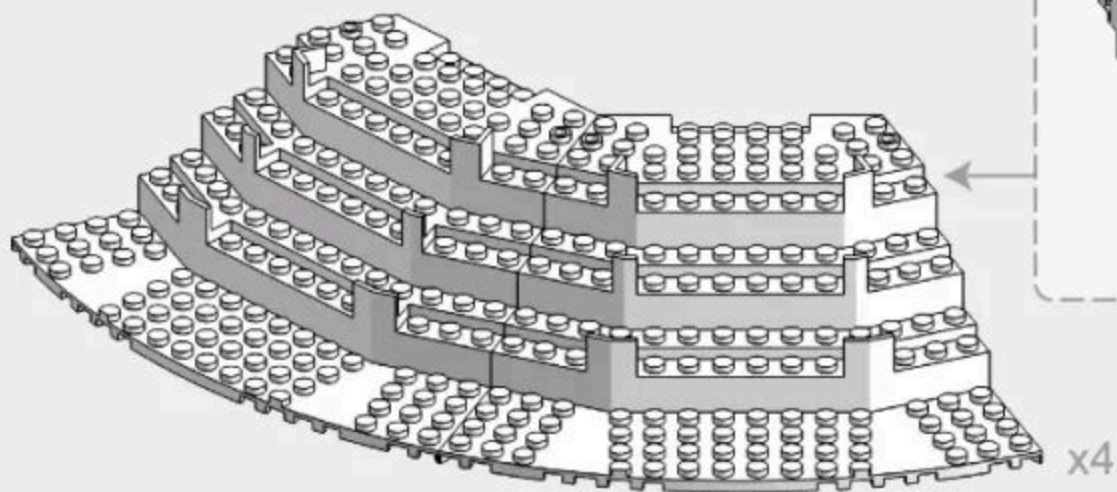
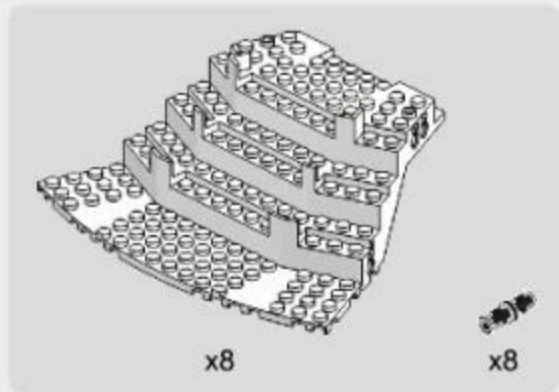

Front Side of Installation Drawing
安装图正面

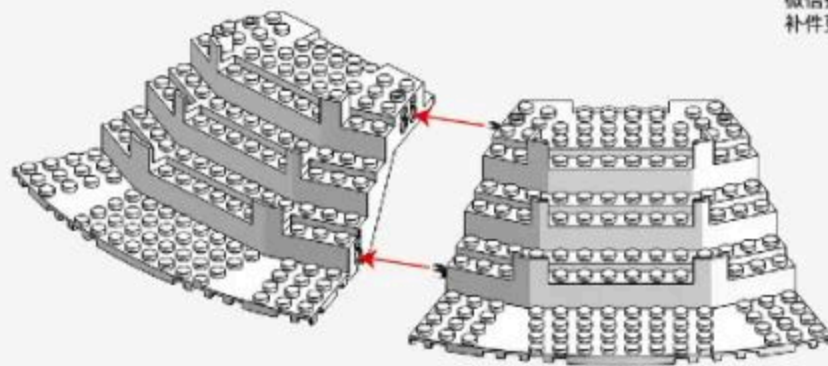

Back Side of Installation Drawing
安装图背面

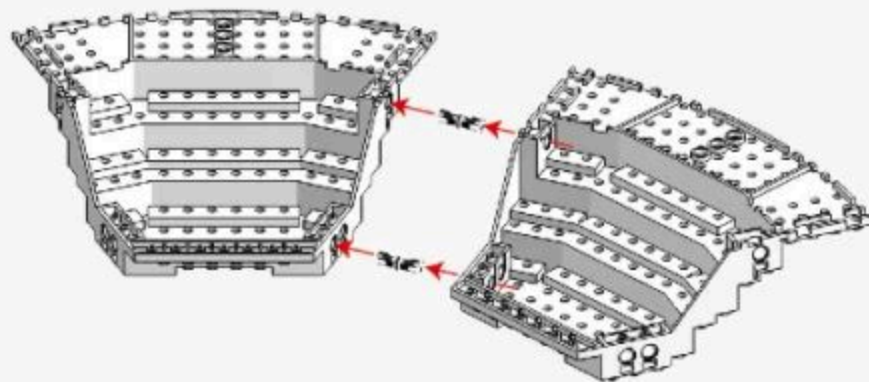

1-2

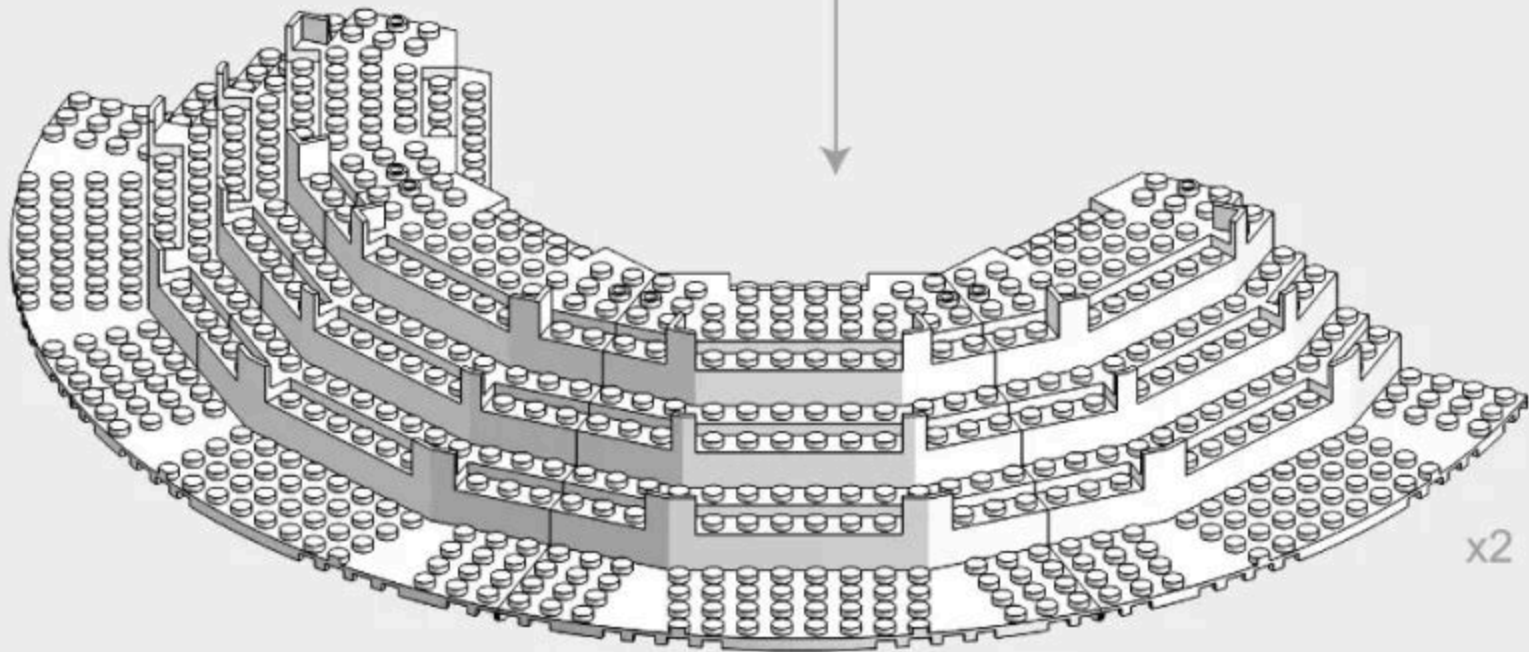
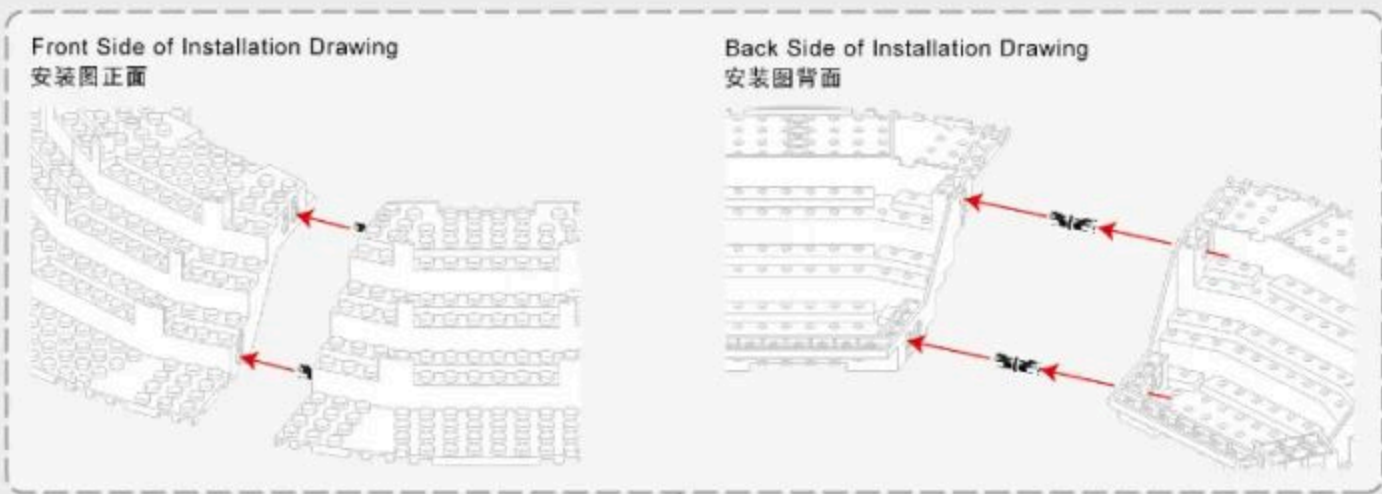

1-3

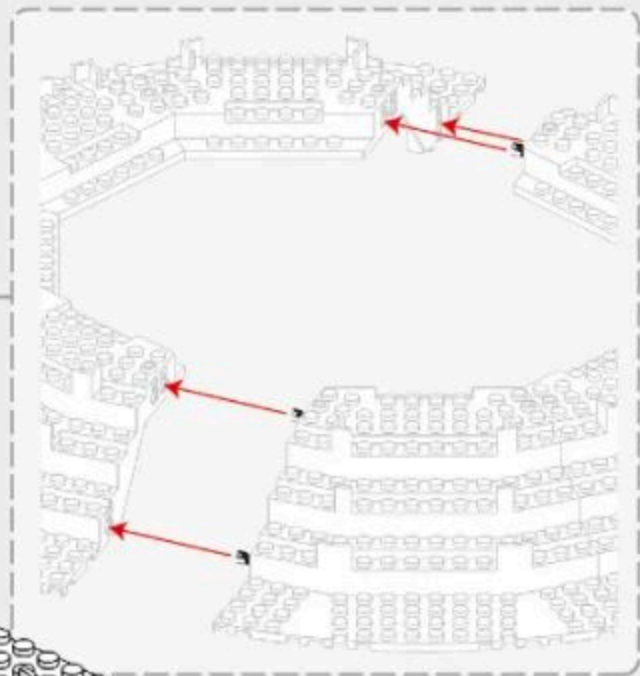
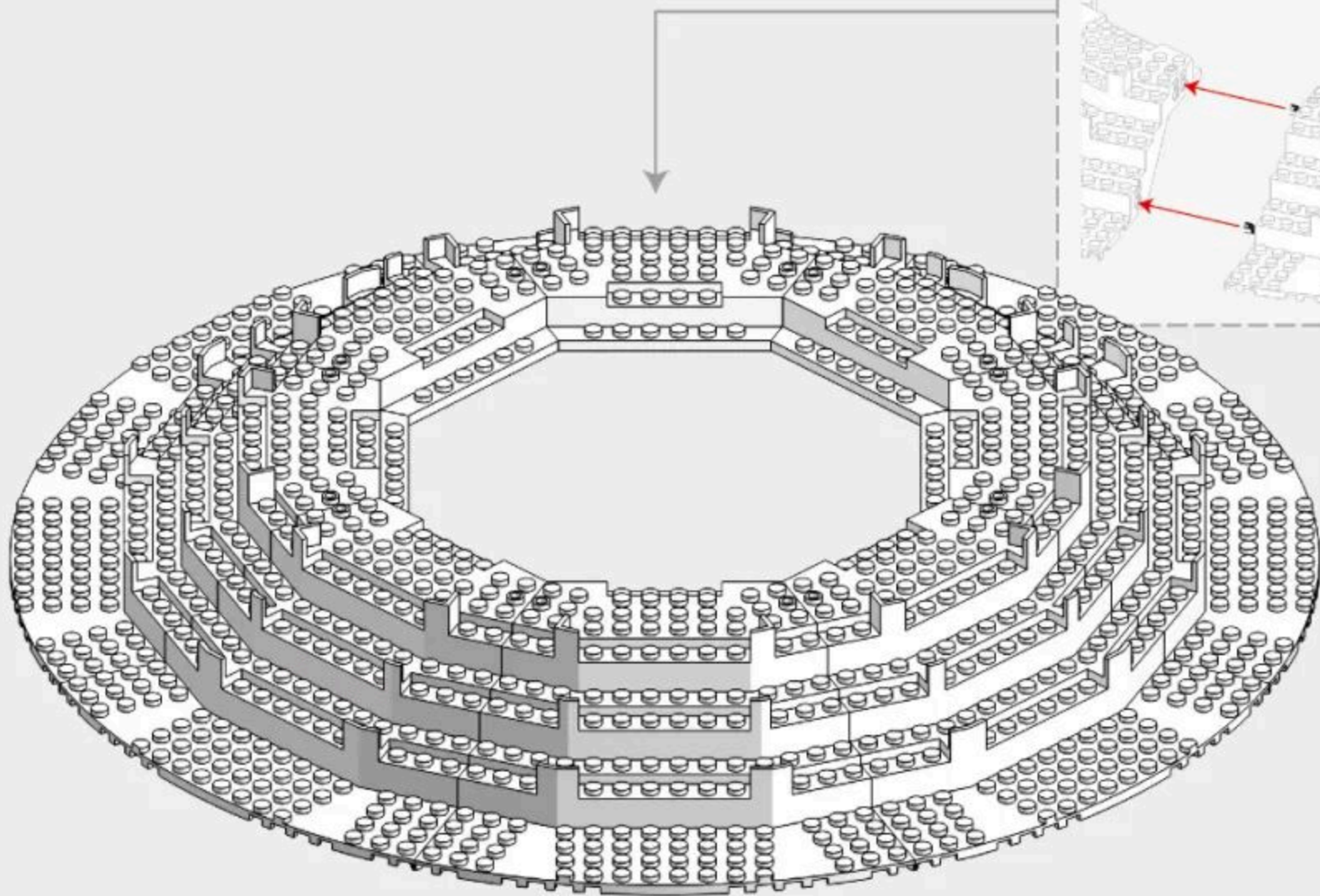

x4

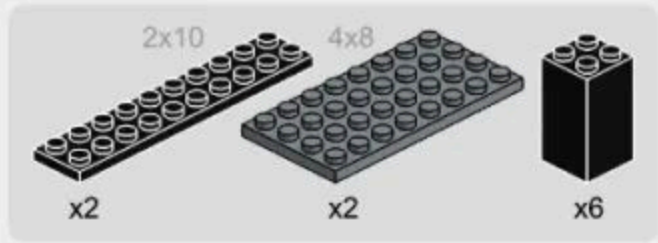

1-4

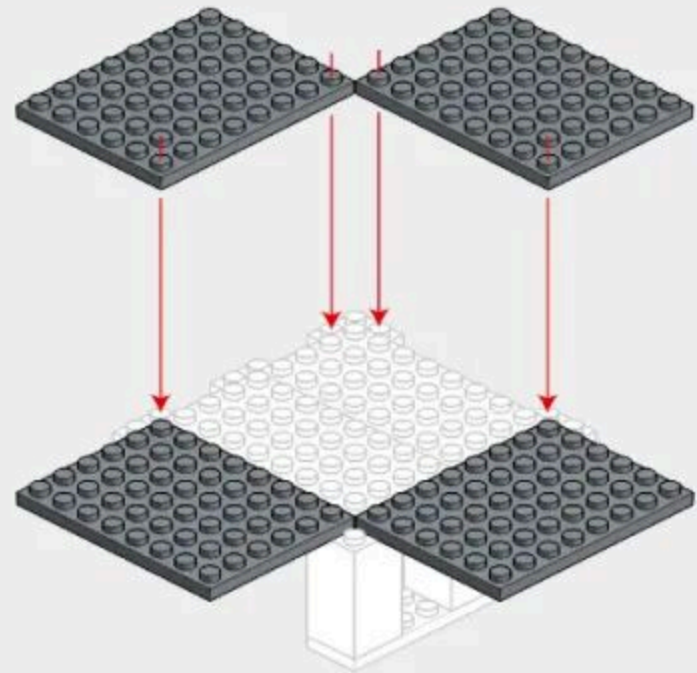
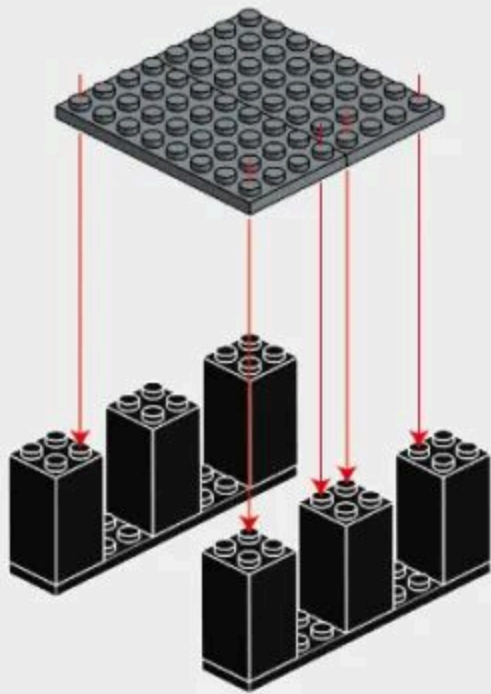
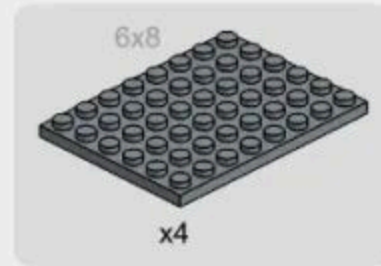

1-5



1-6

1-5

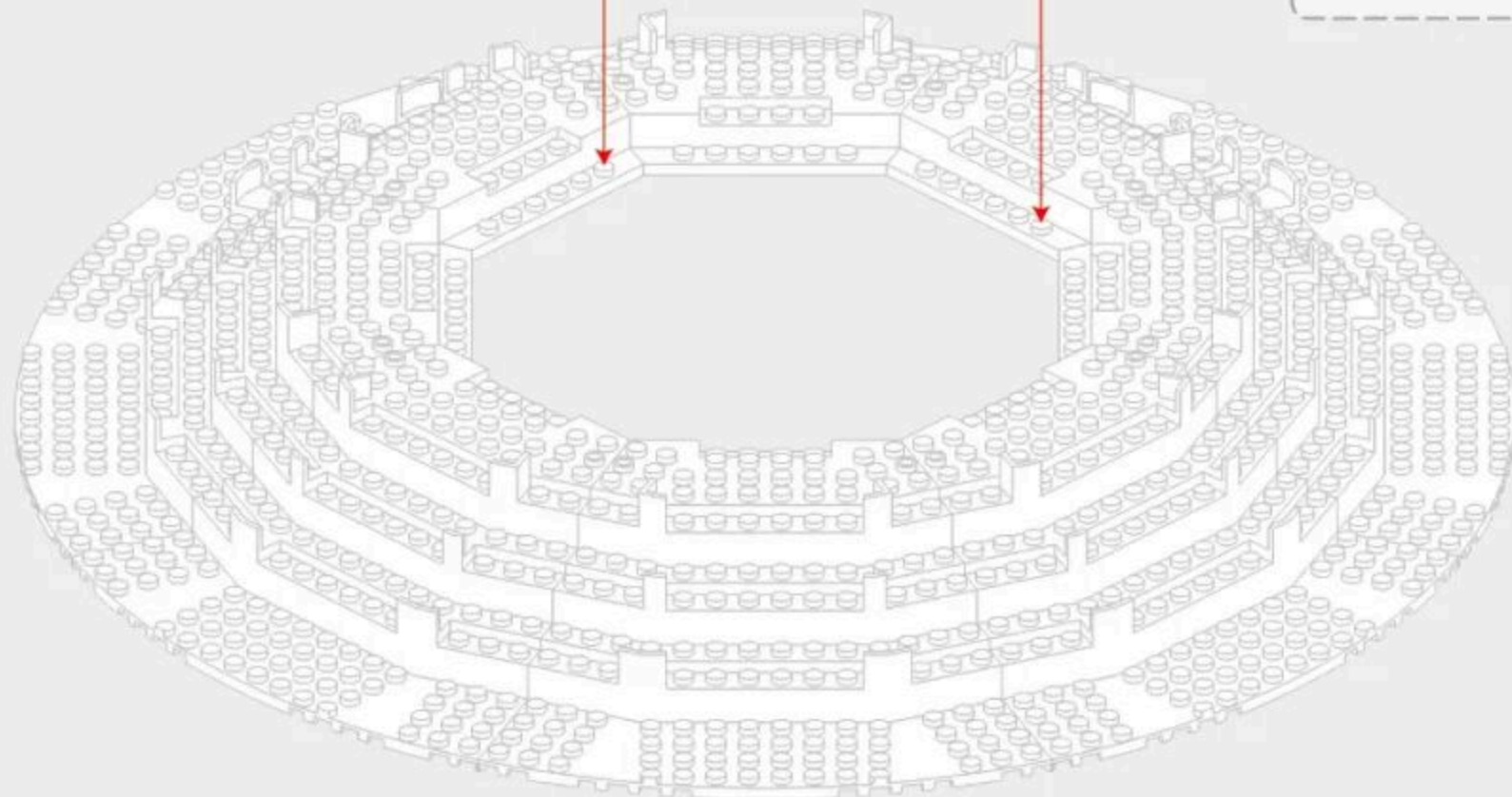
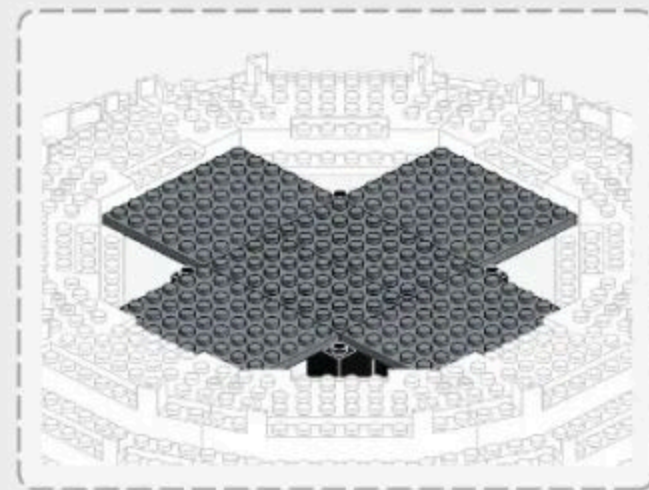
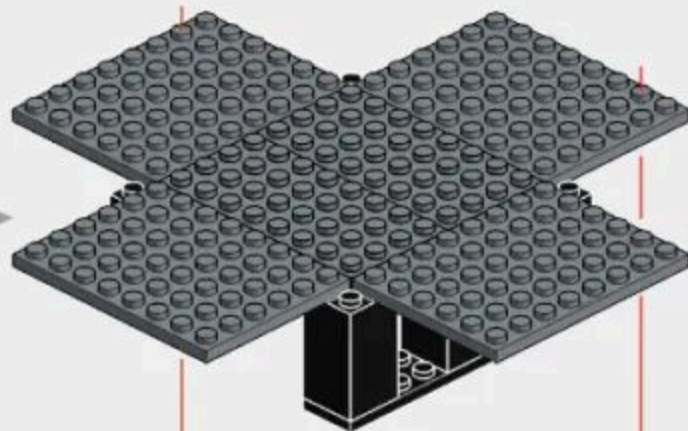

1-3

22

1-7



x8



x4

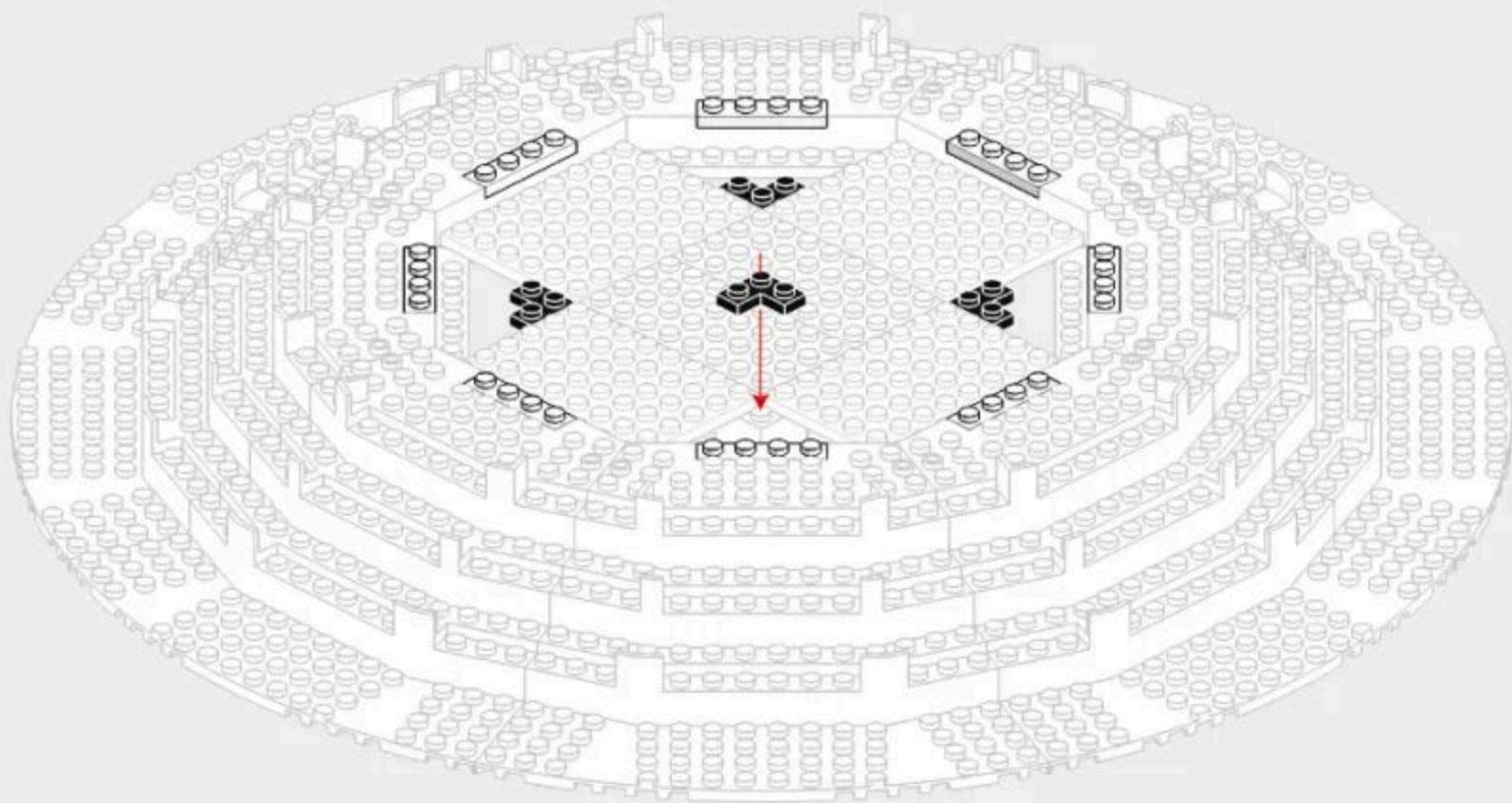

1-8

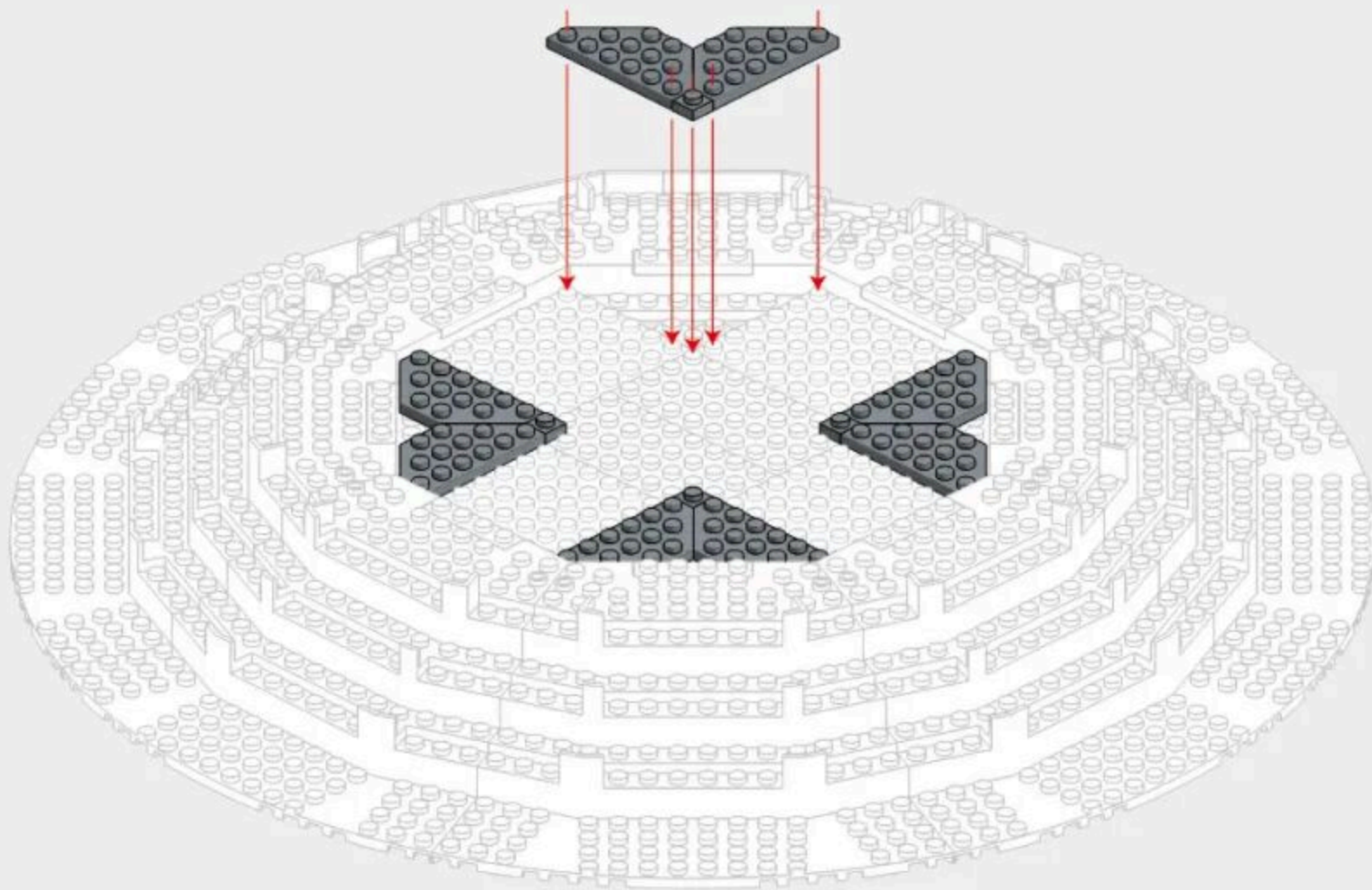
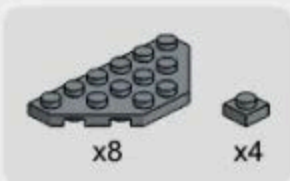

1-9



Vertical View of Installation Drawing
安装图顶面

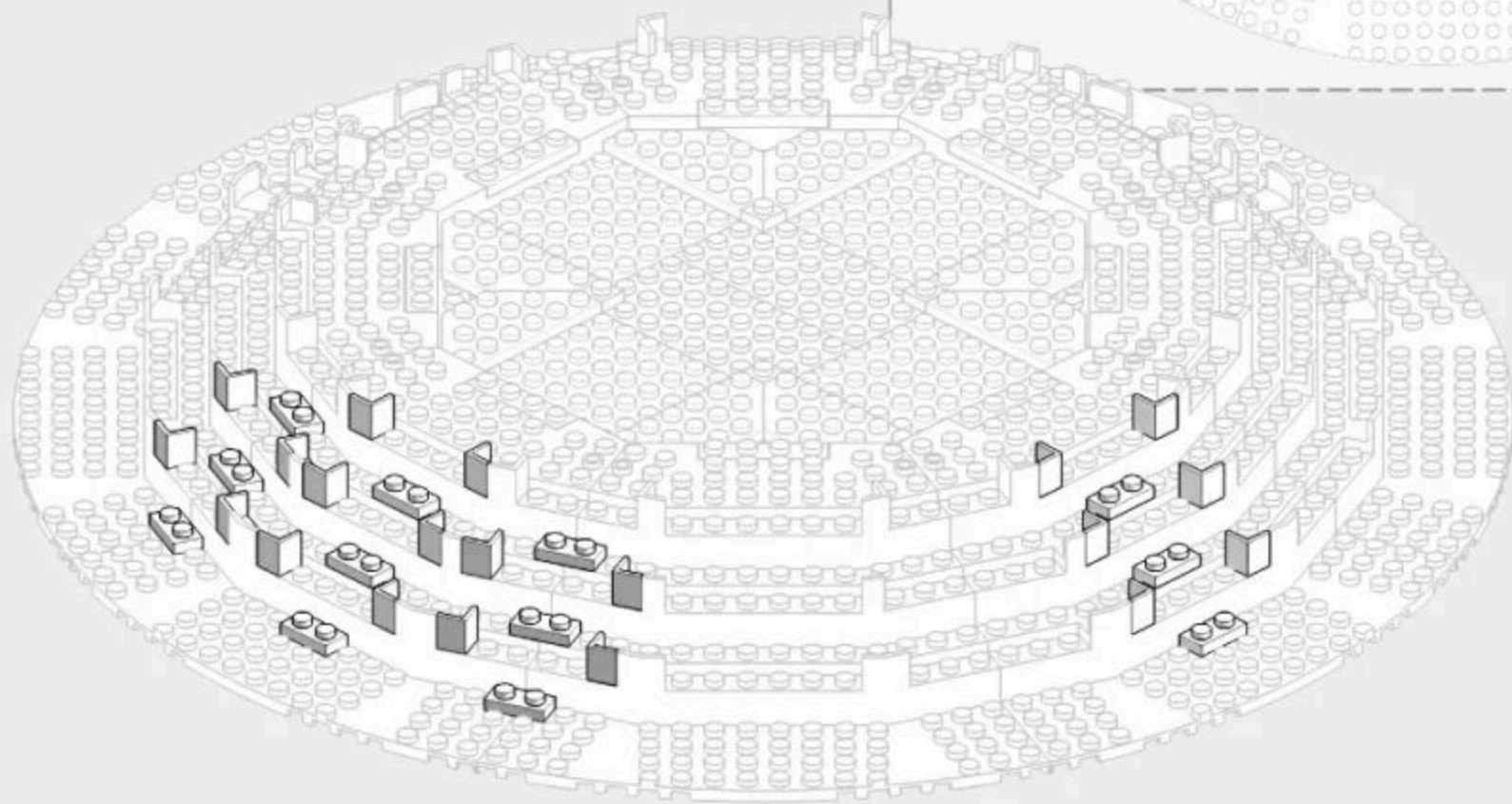
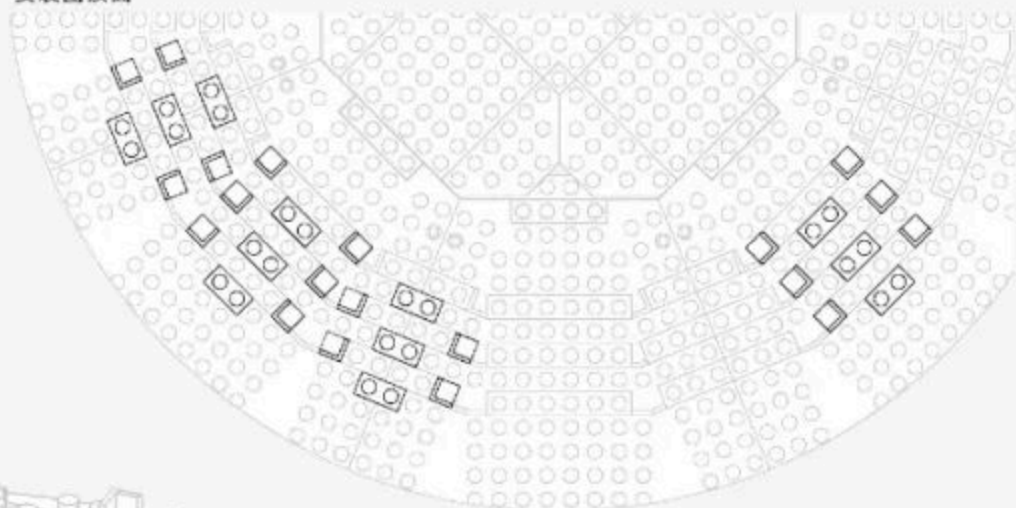

1-10



Vertical View of Installation Drawing

安装图顶面

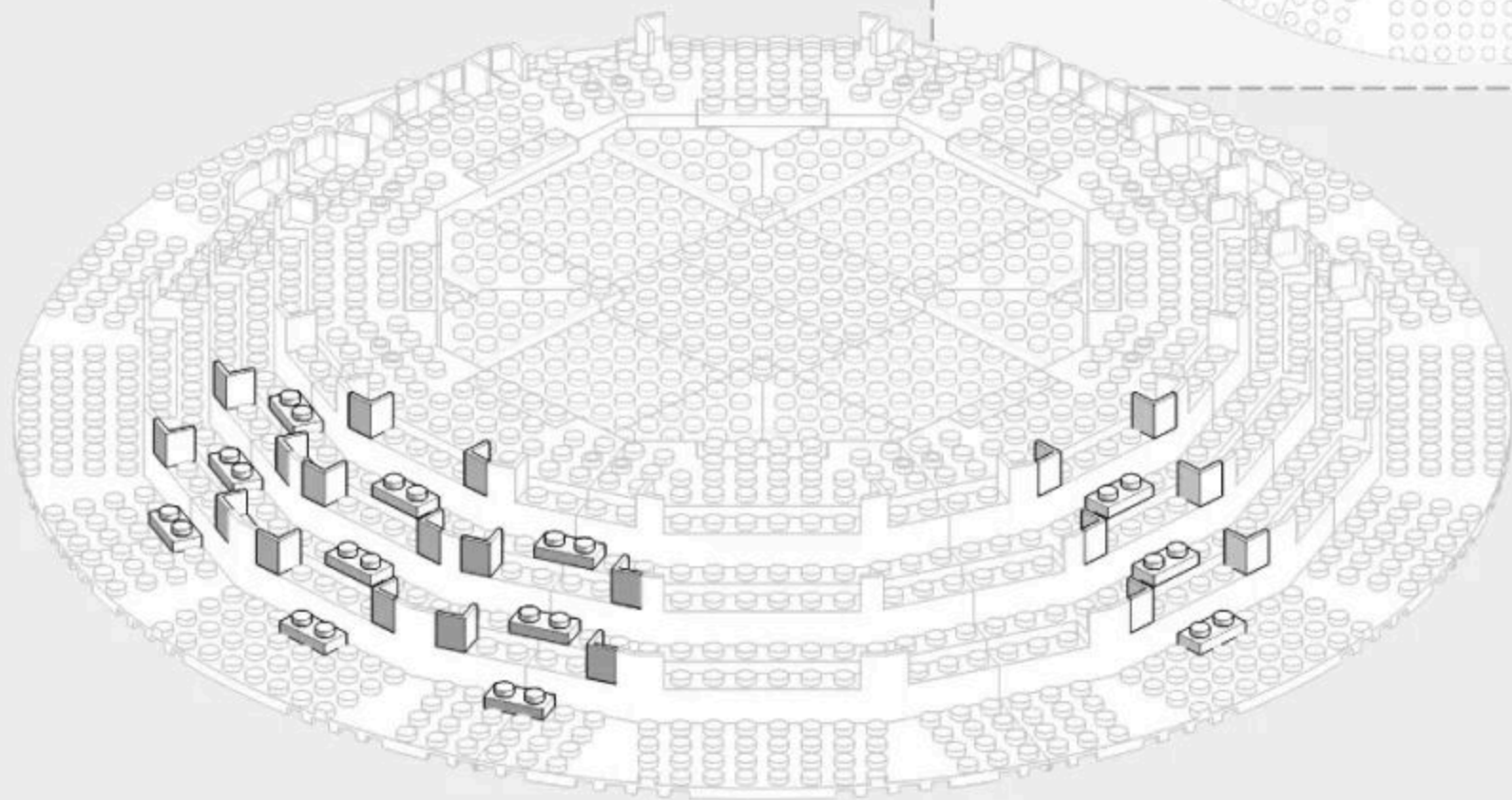
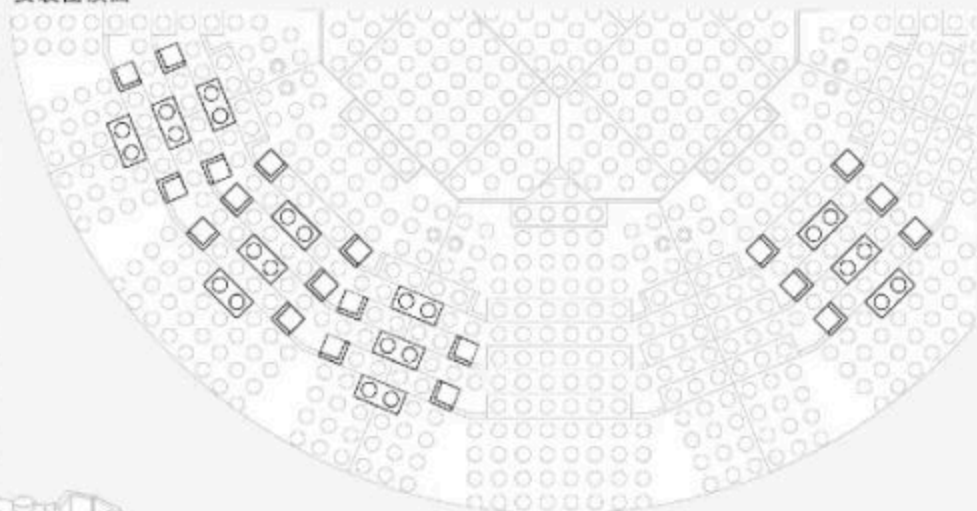

1-11

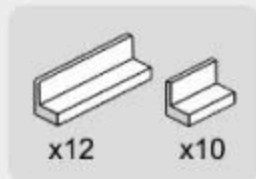

Vertical View of Installation Drawing
安装图顶面

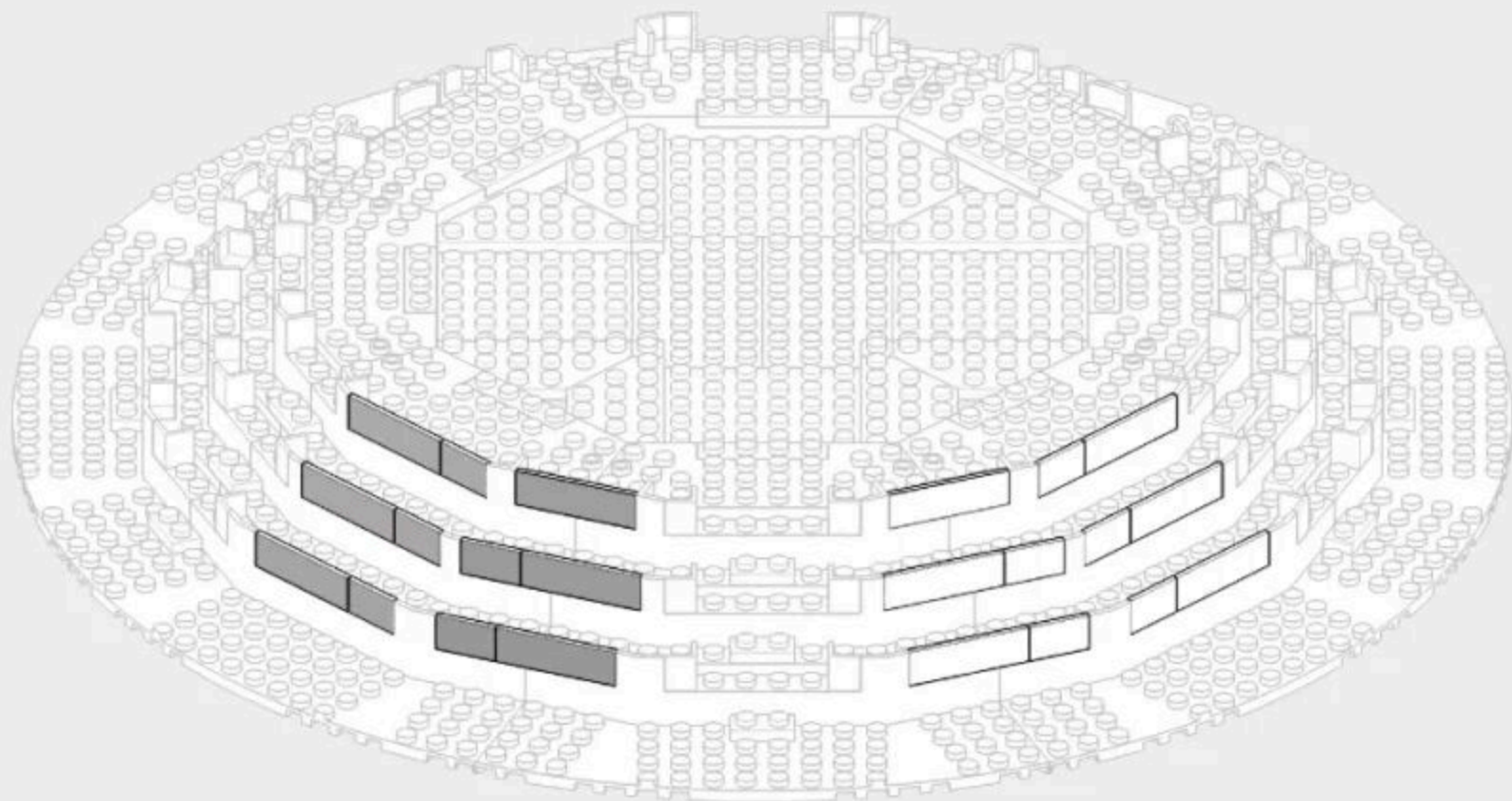
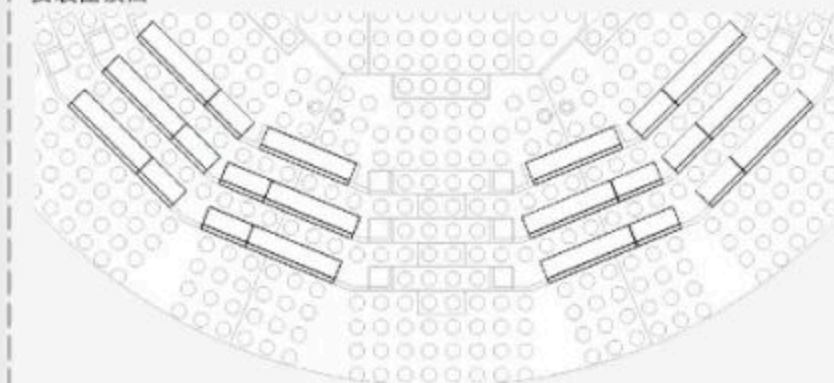

1-12

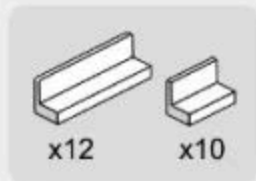

Vertical View of Installation Drawing
安装图顶面

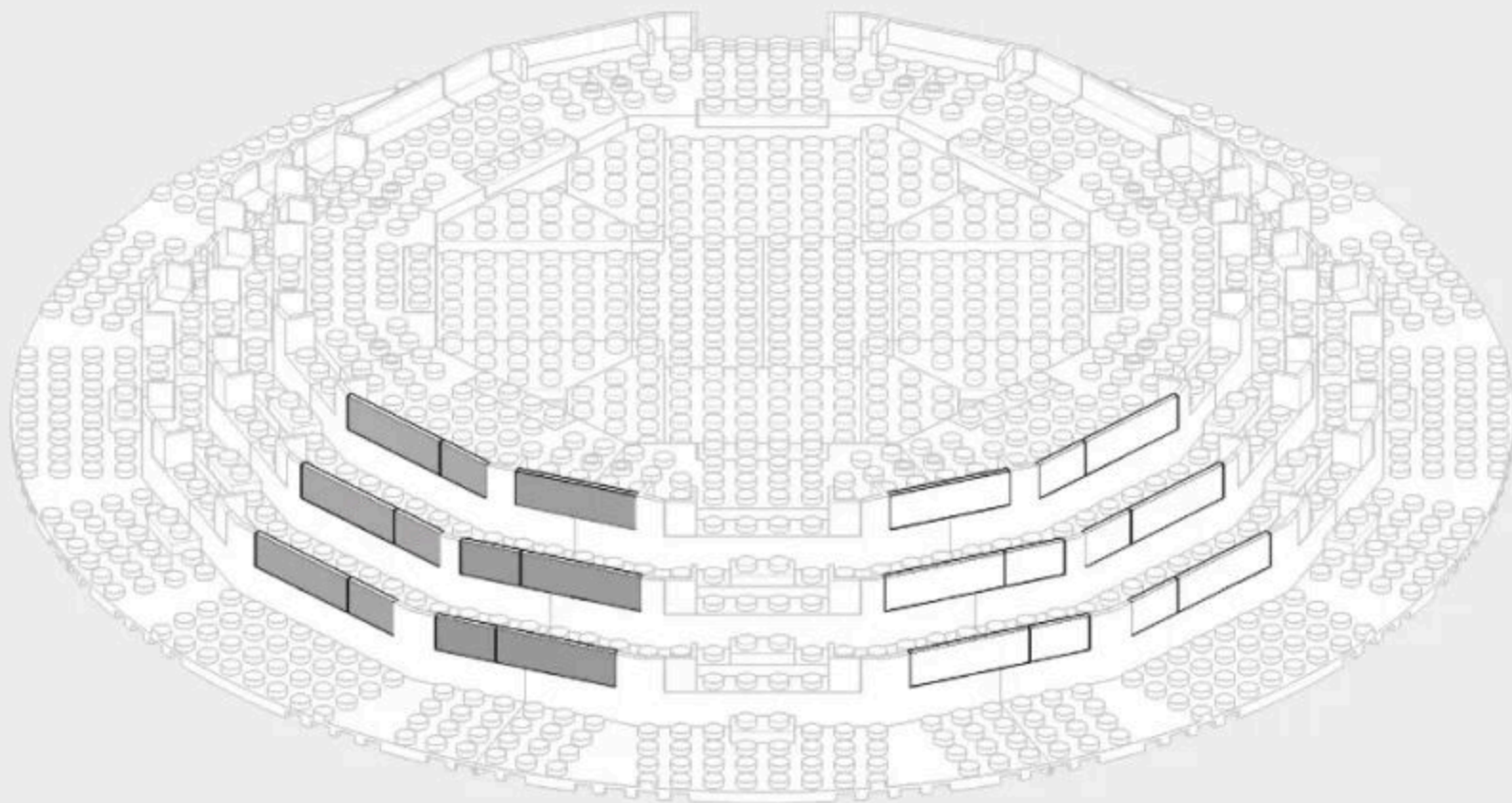
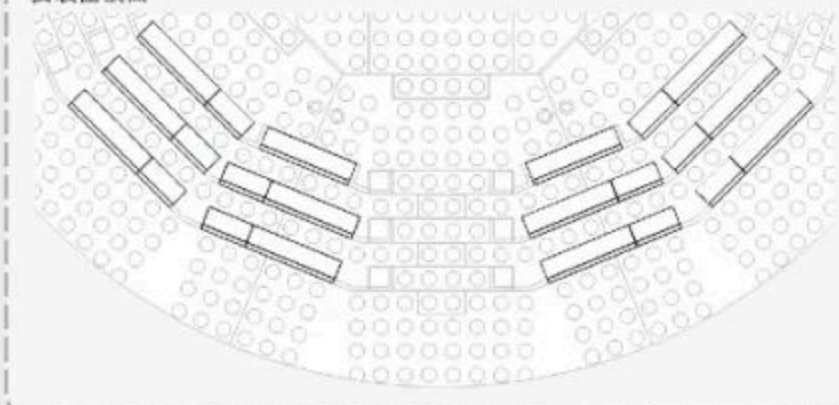



224PCS

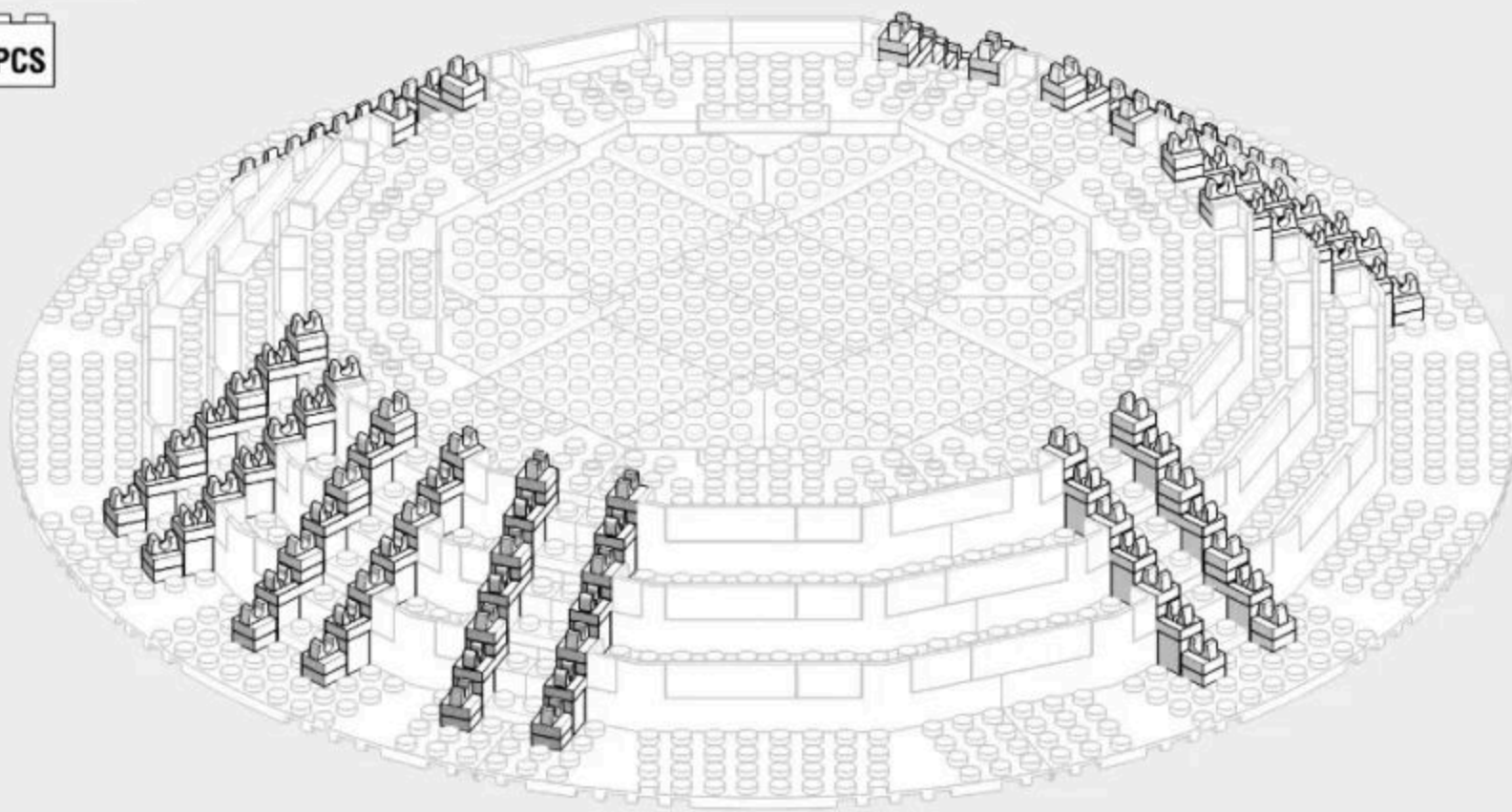

2-1



x24



Vertical View of Installation Drawing

安装图顶面

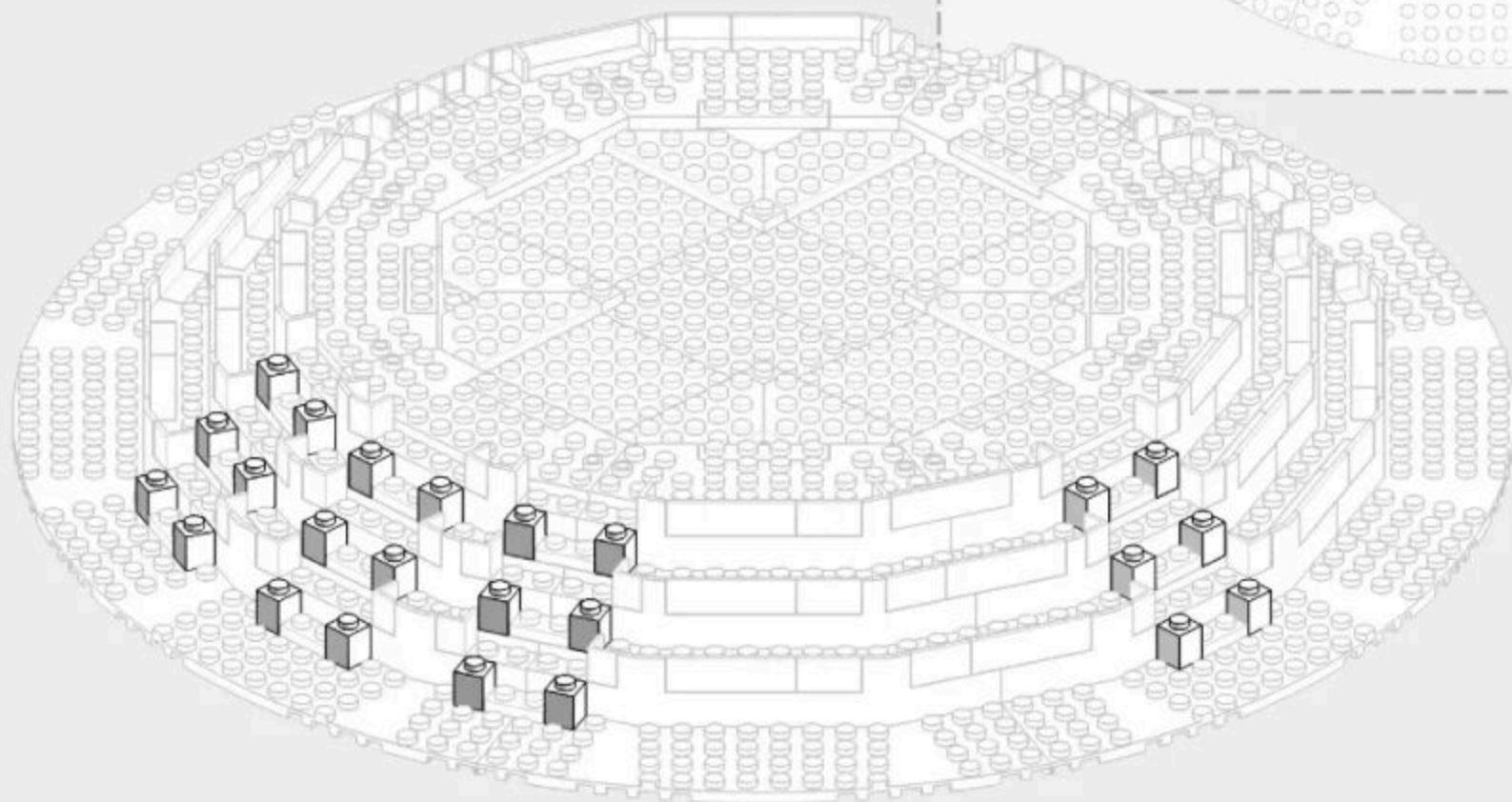
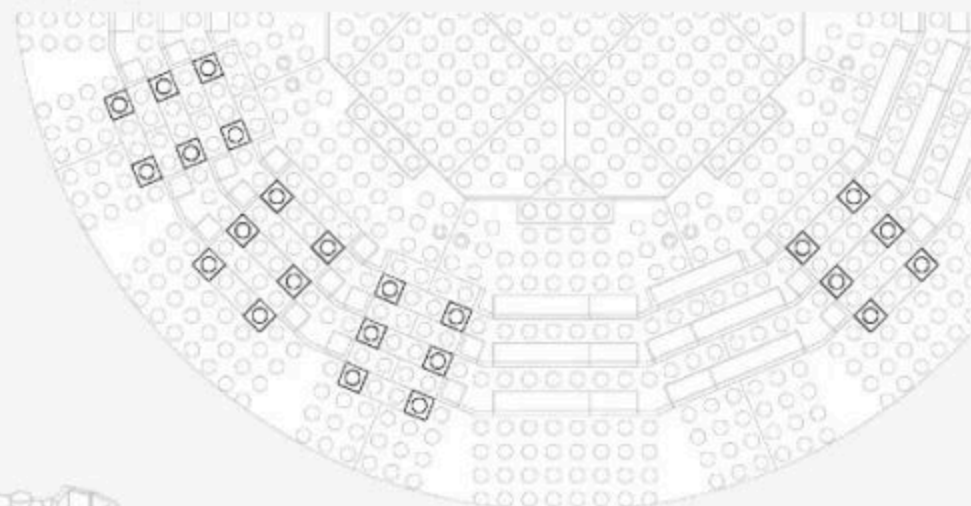

30

2-2



Vertical View of Installation Drawing
安装图顶面

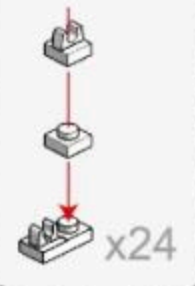
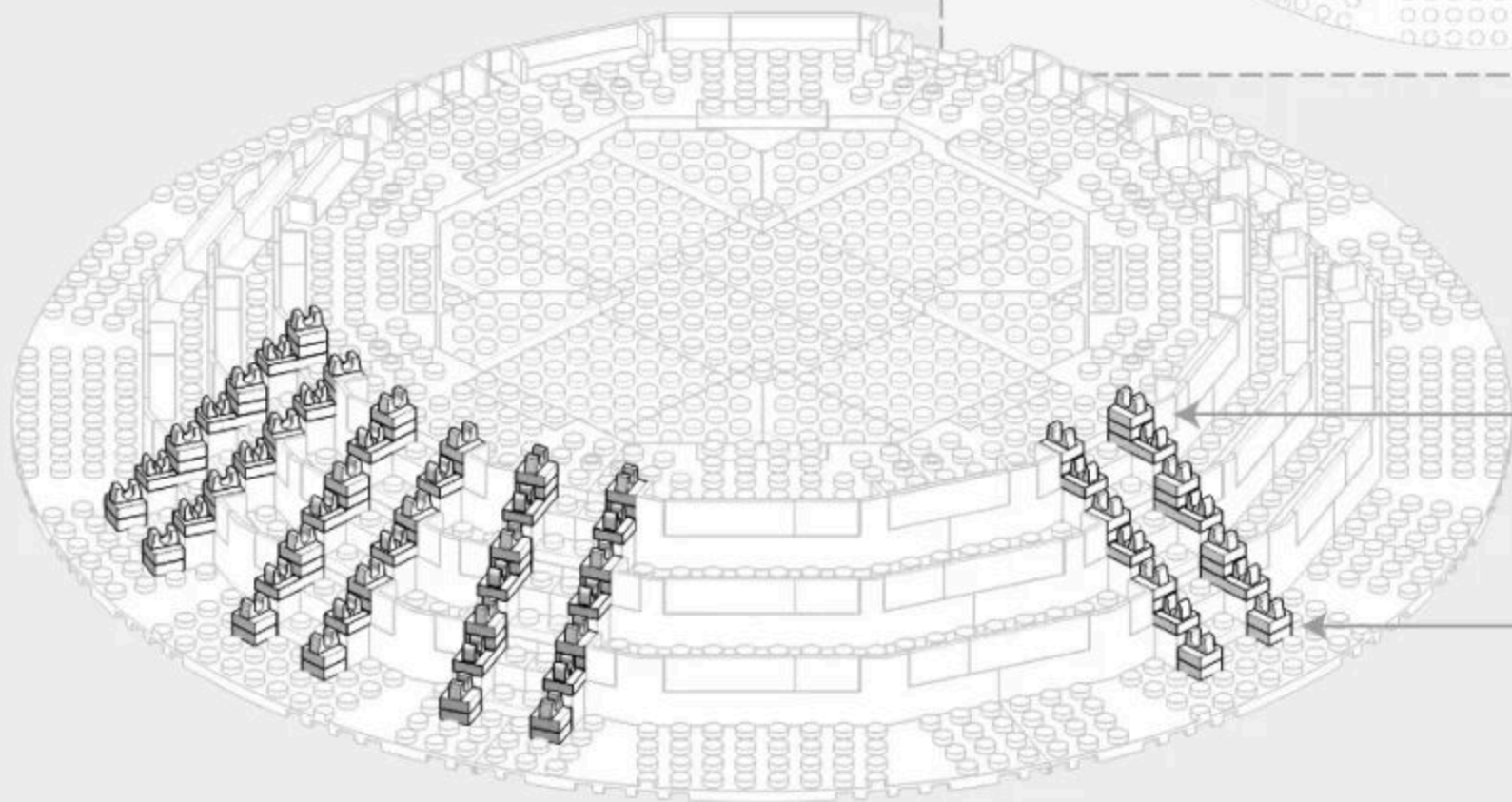
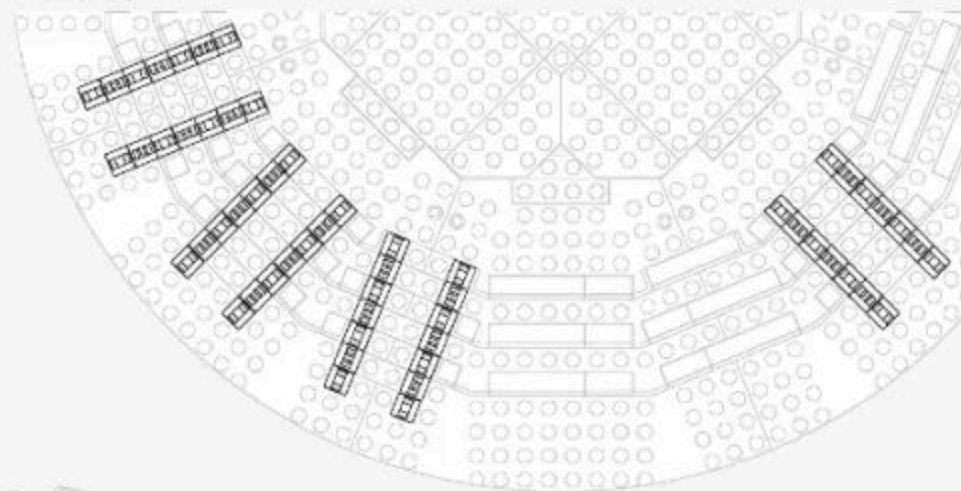

2-3



x24



Vertical View of Installation Drawing

安装图顶面

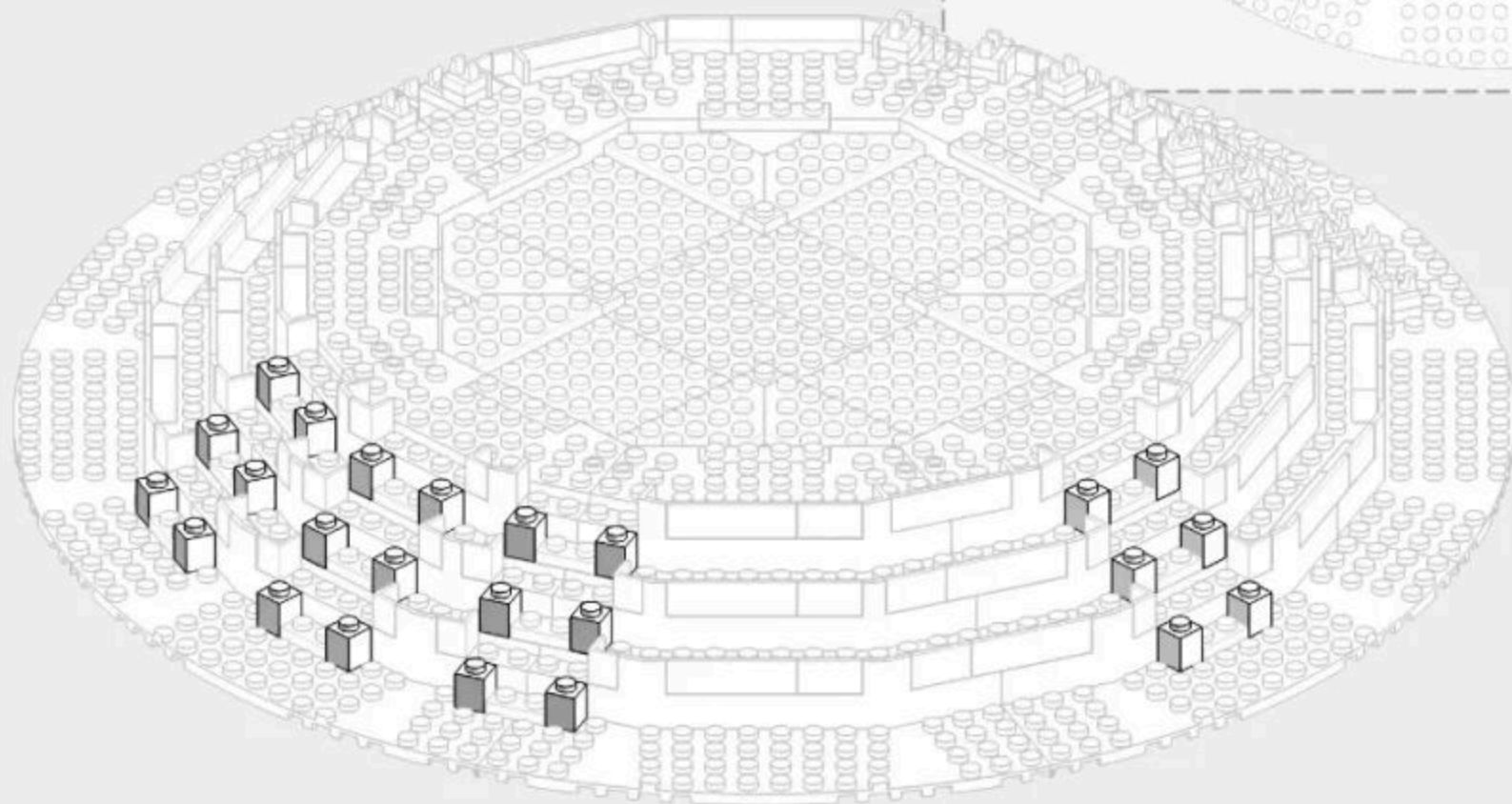
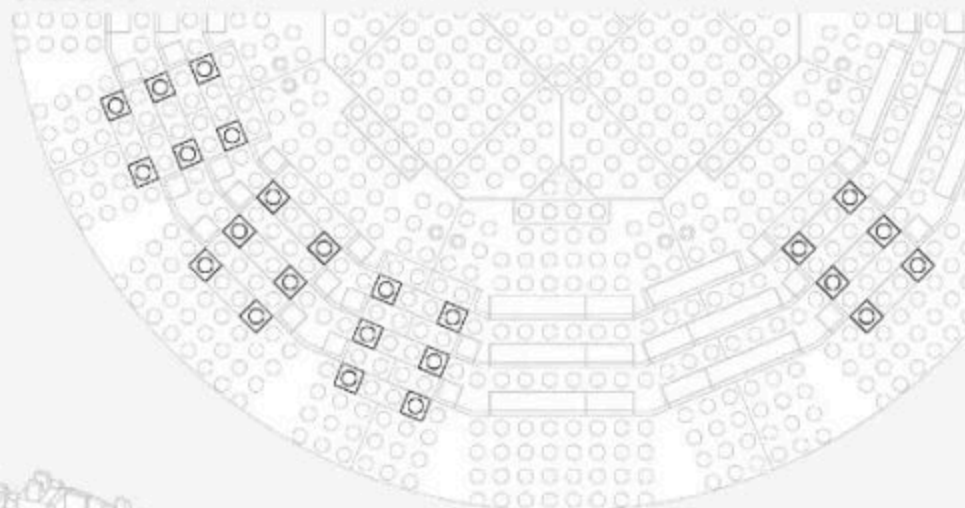

2-4



Vertical View of Installation Drawing
安装图顶面

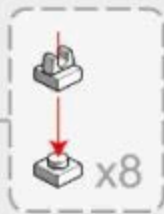
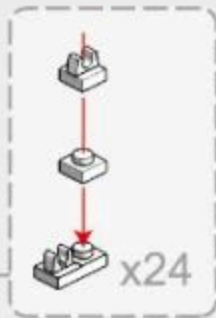
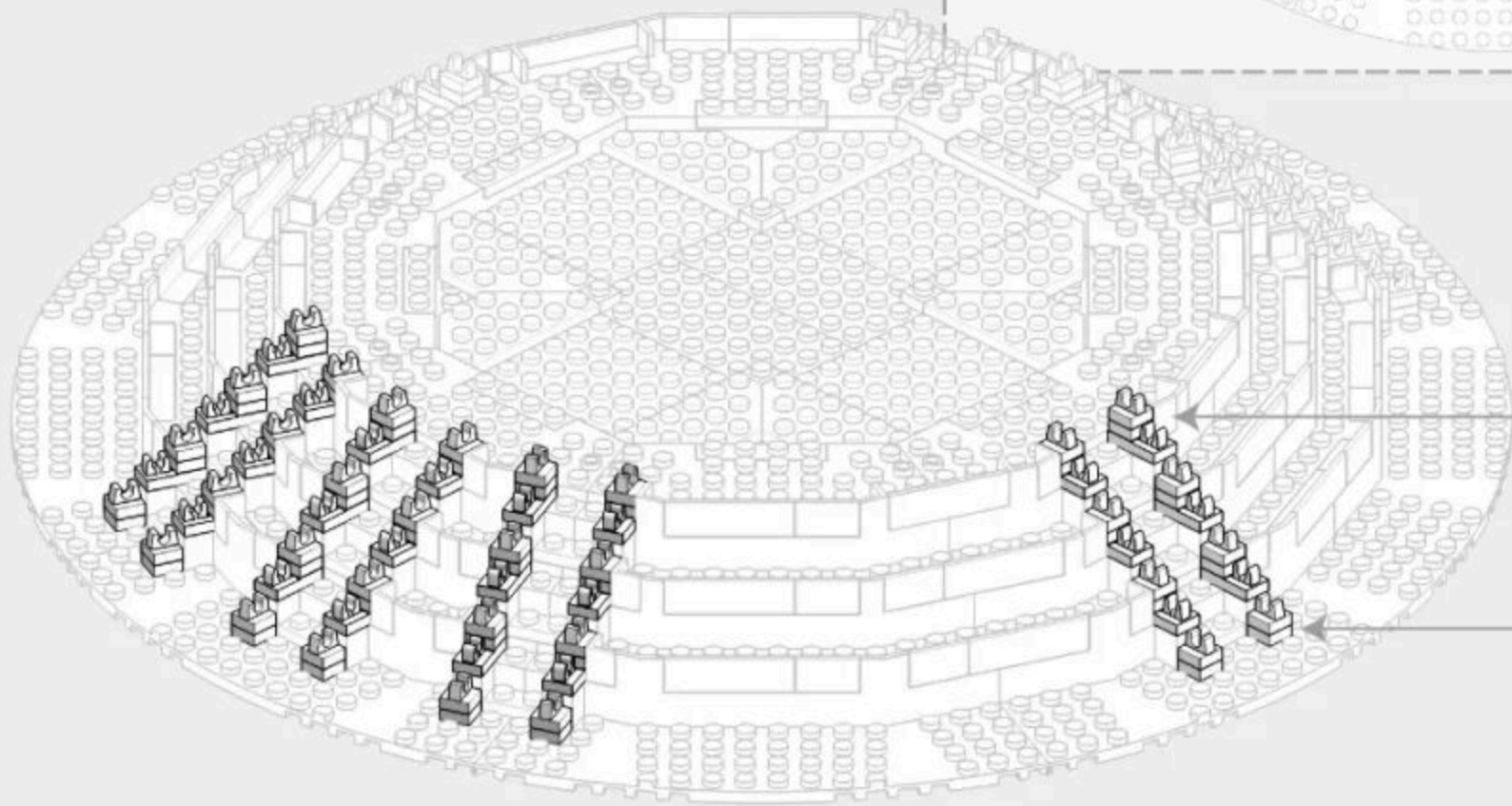
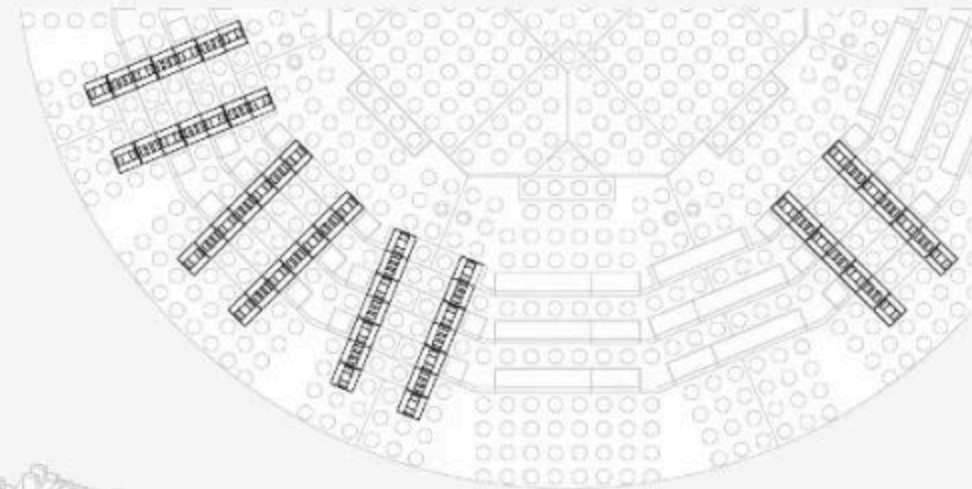



223PCS

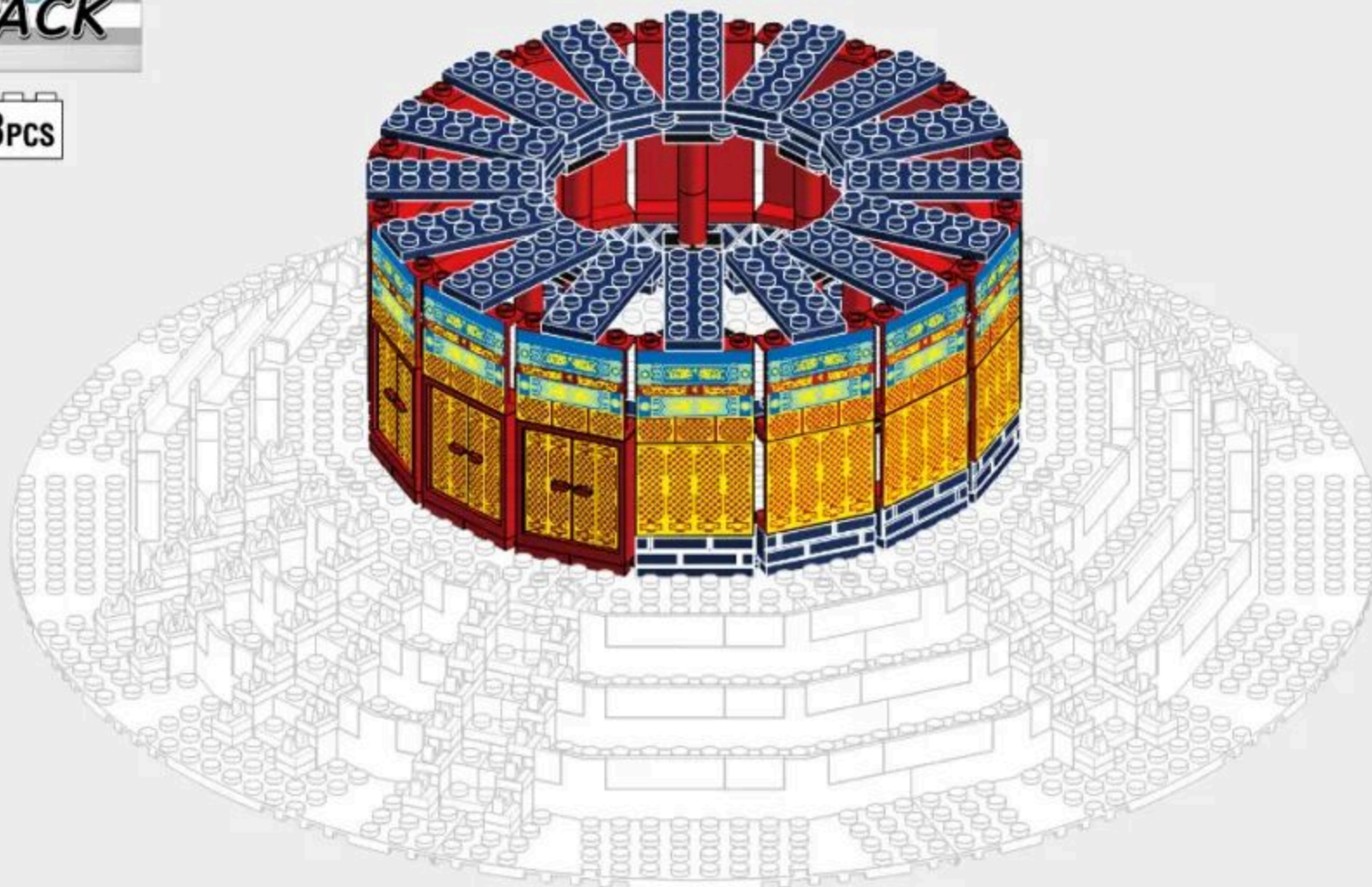

3-1

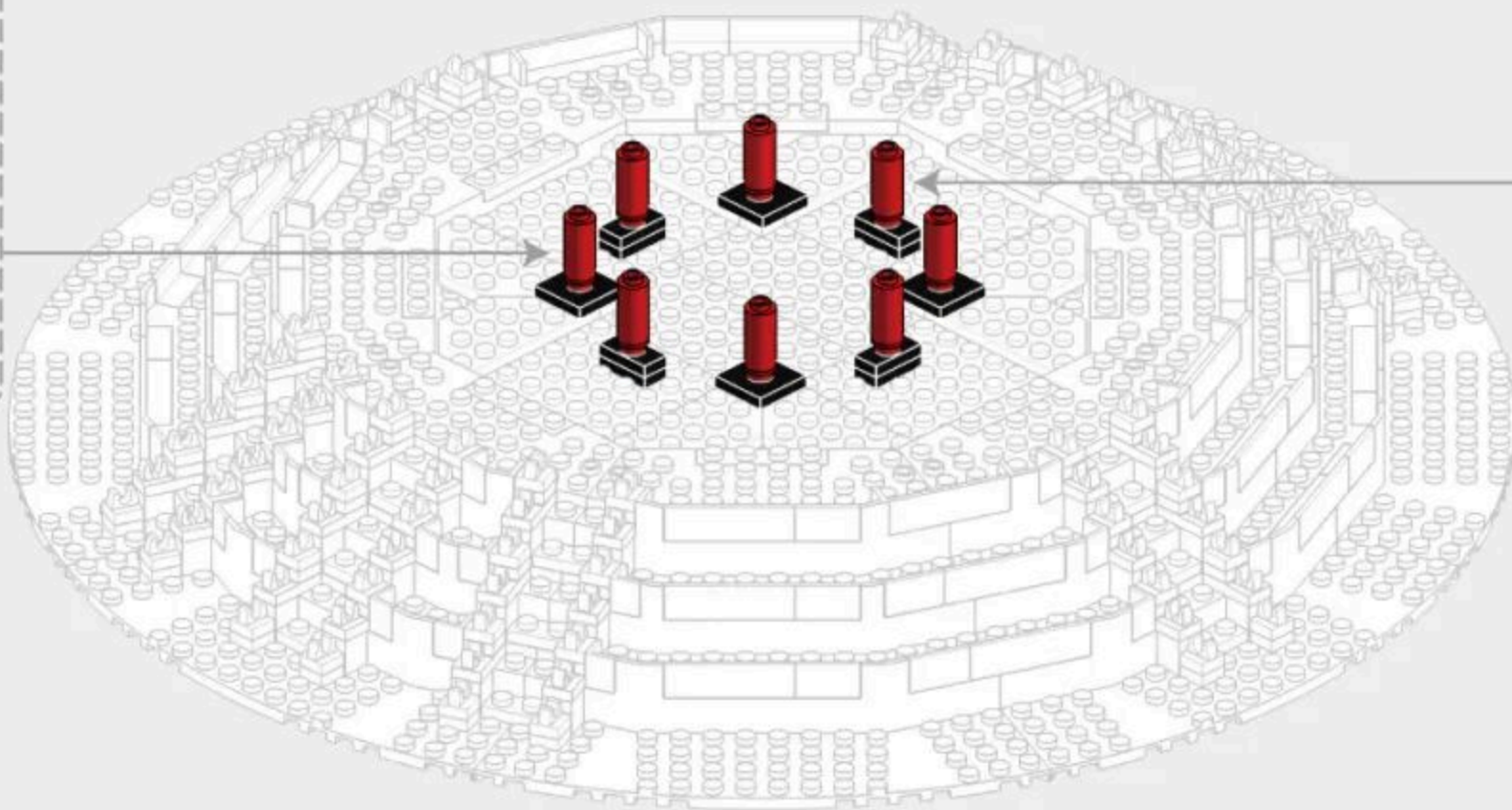
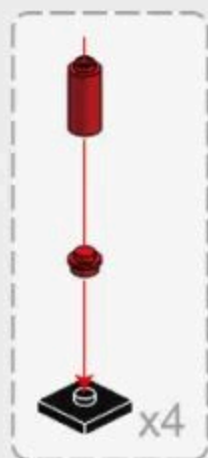

3-2

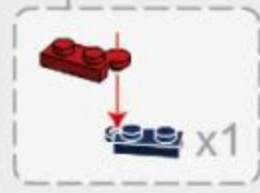
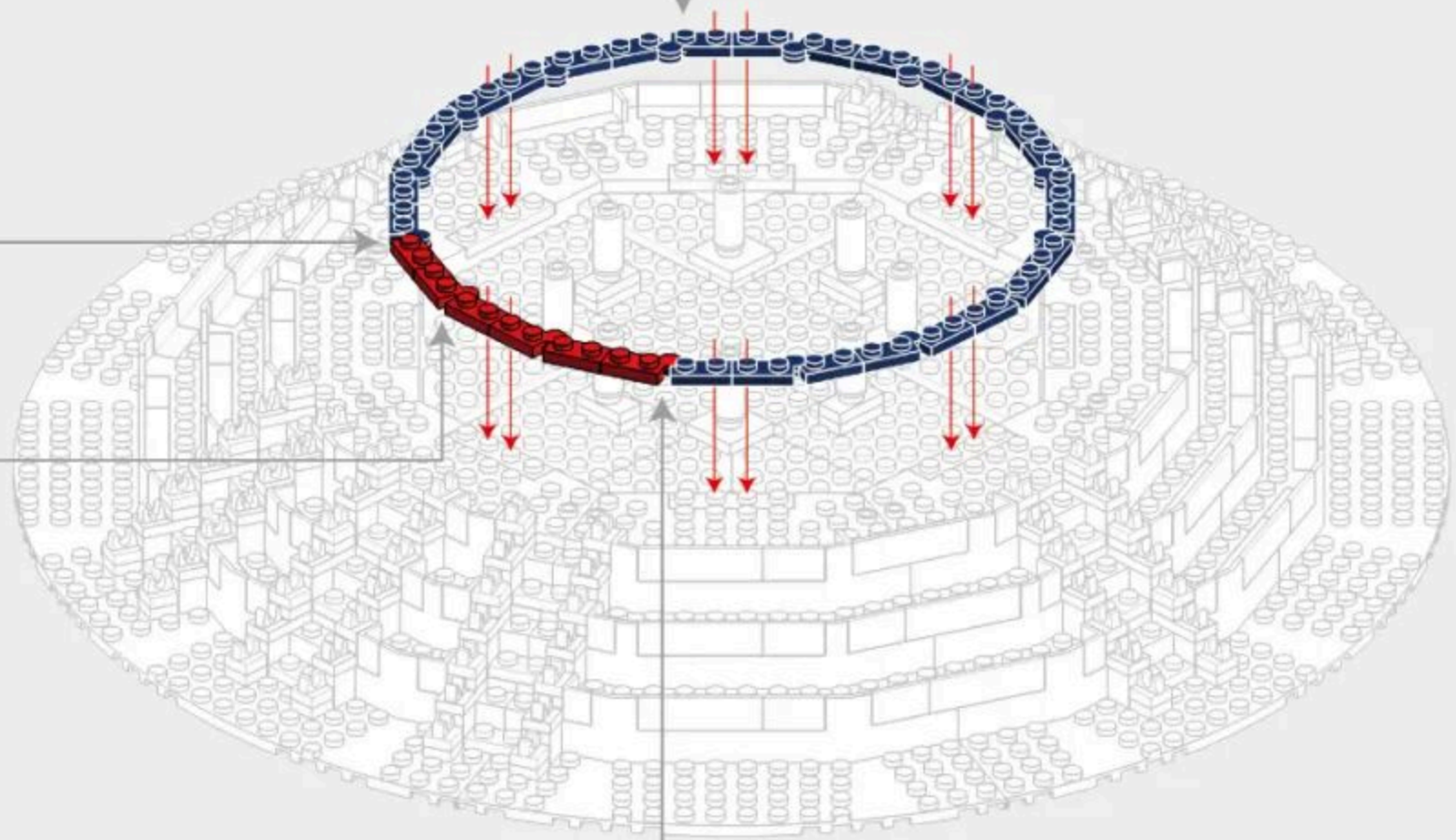
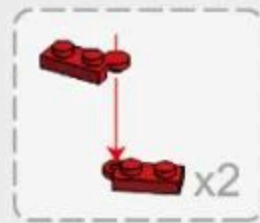

3-3

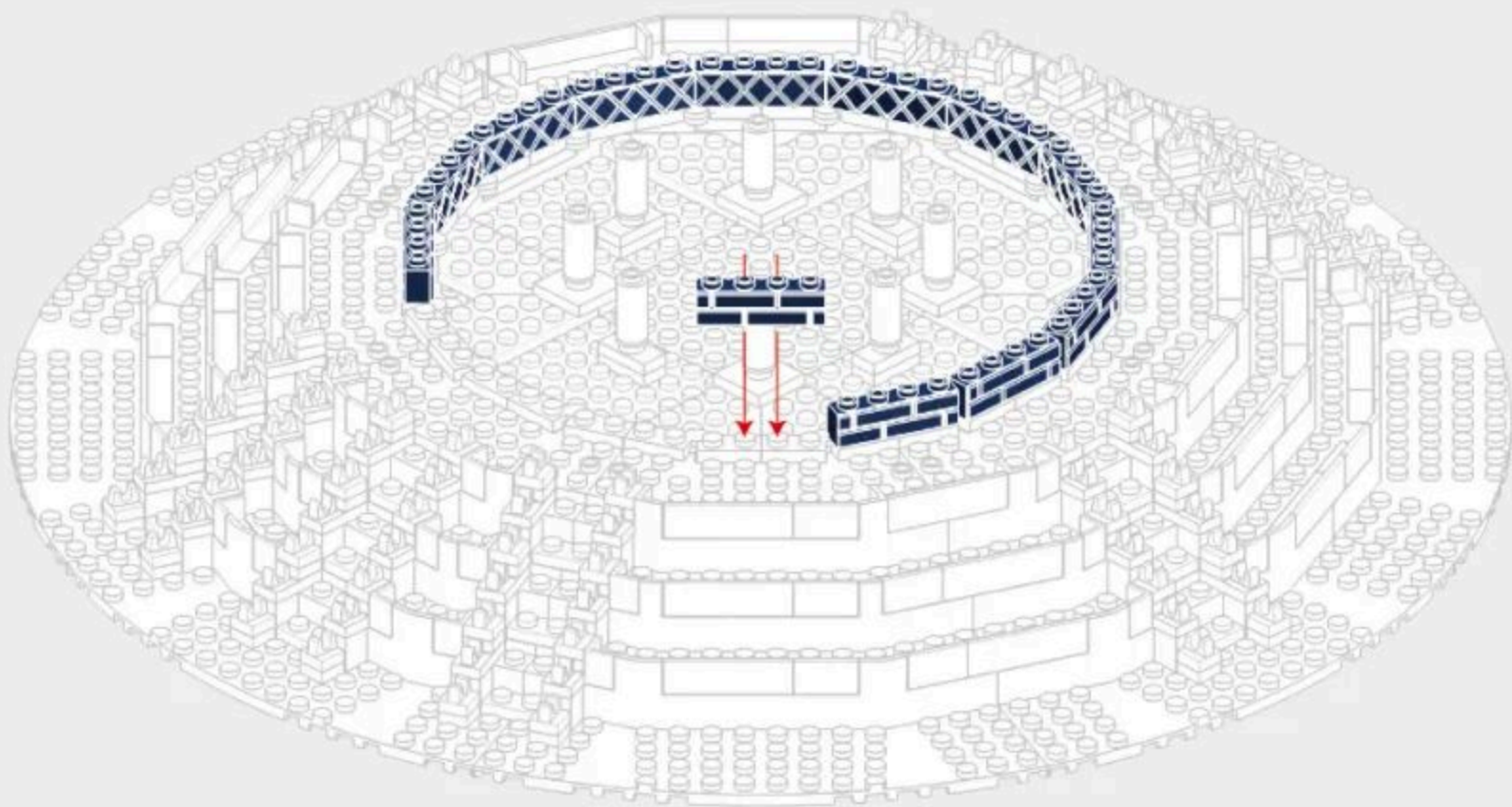

3-4

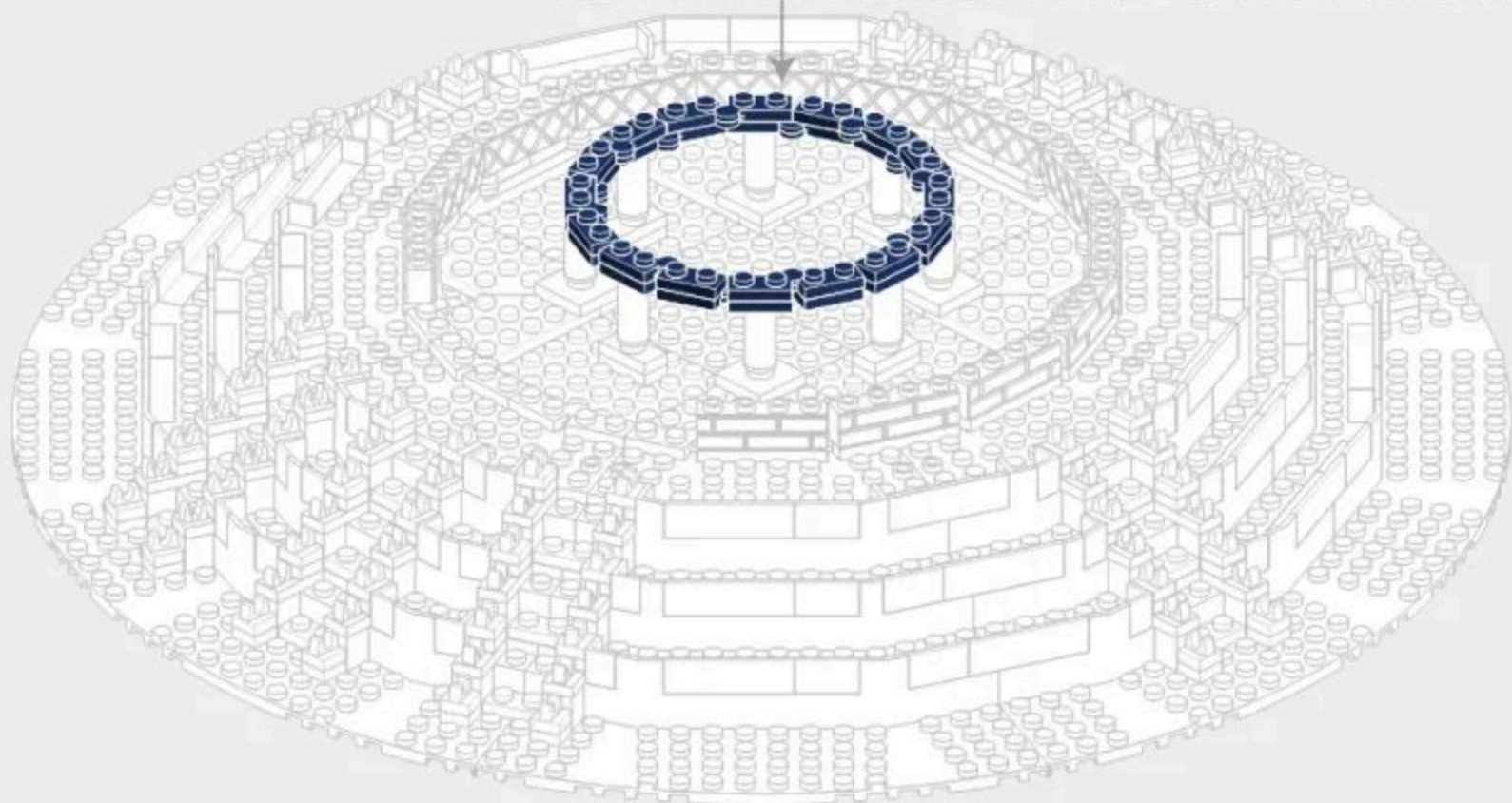
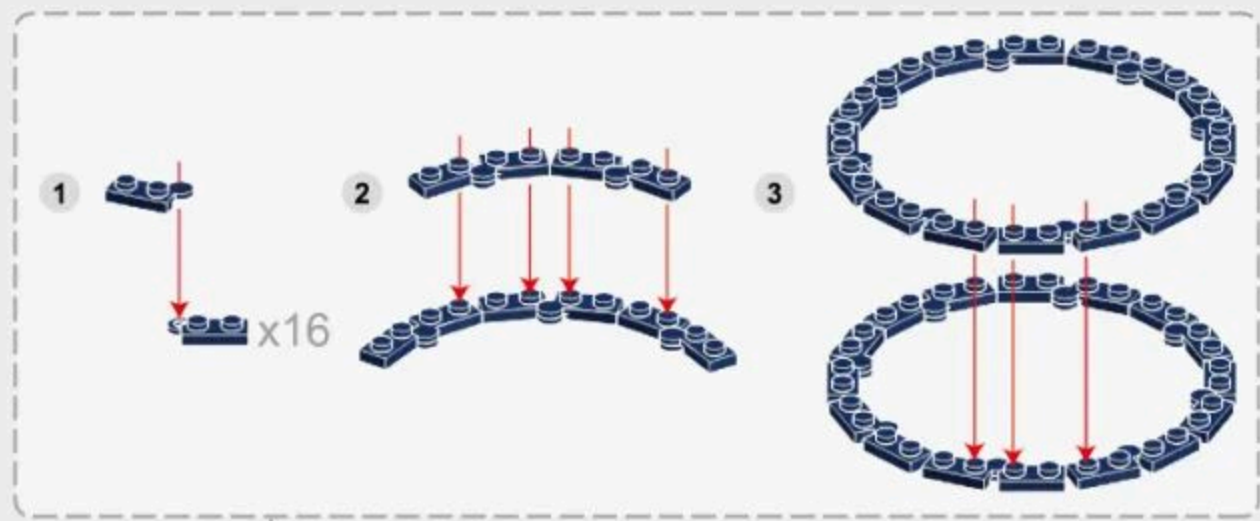

3-5

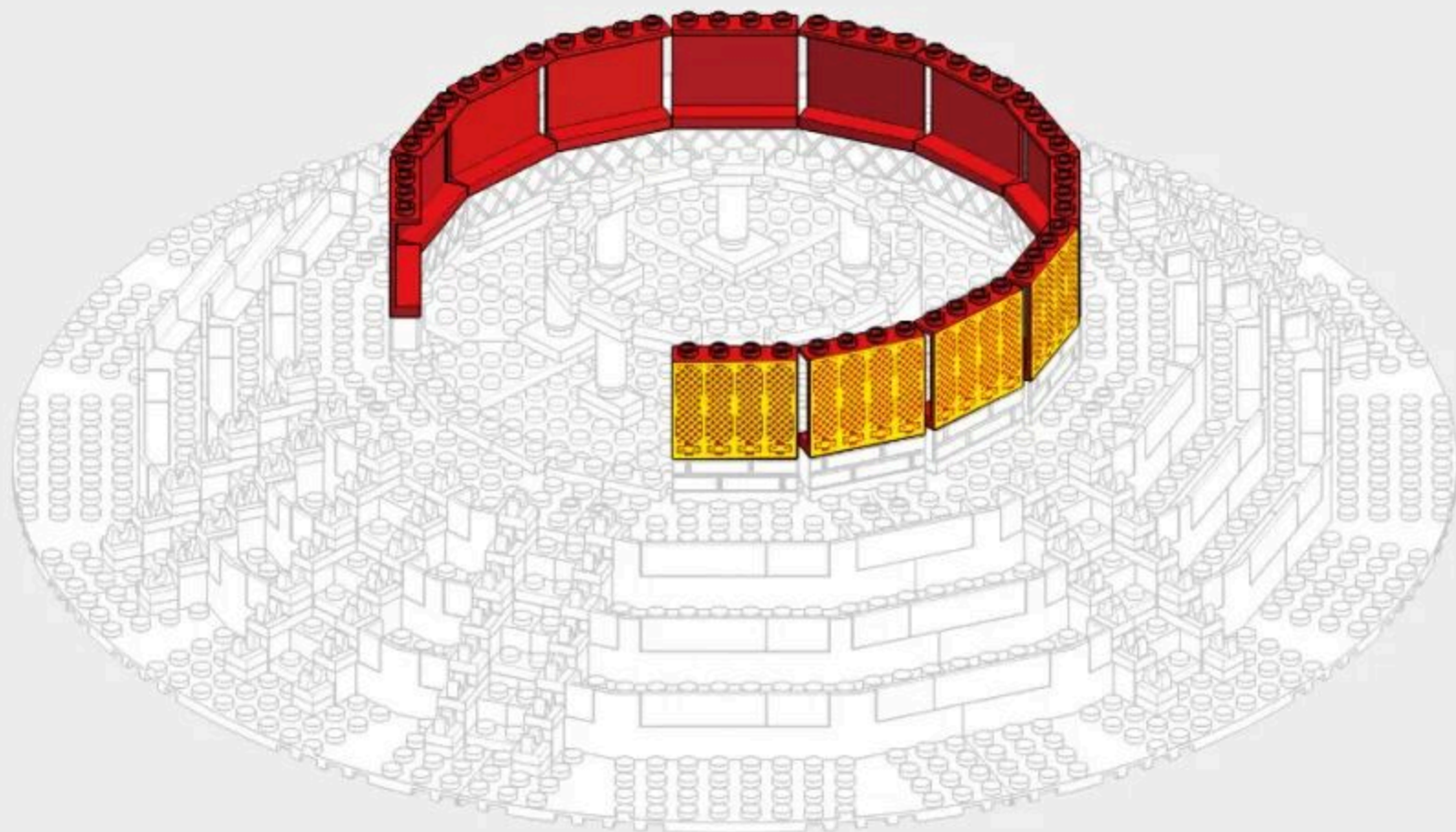

3-6

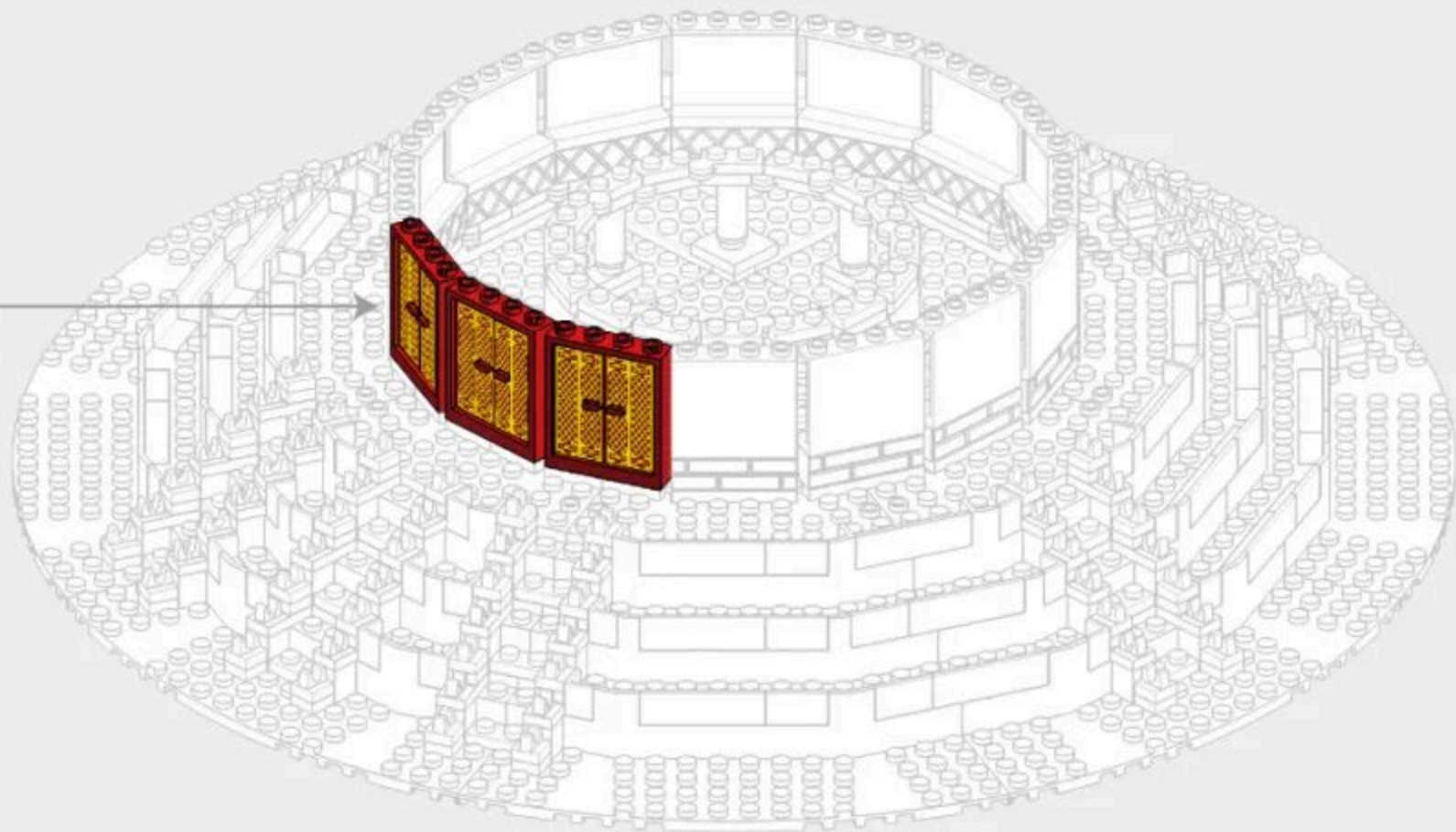
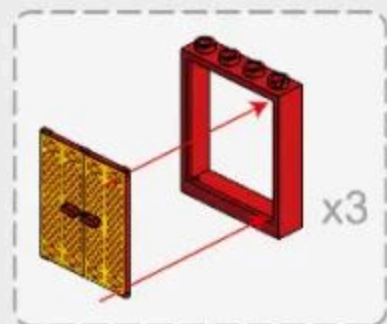

3-7

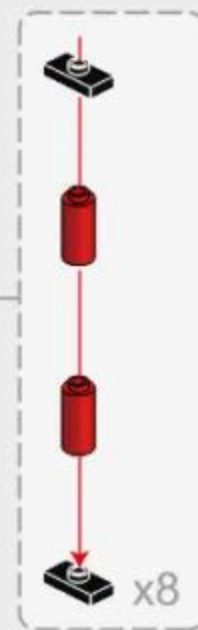
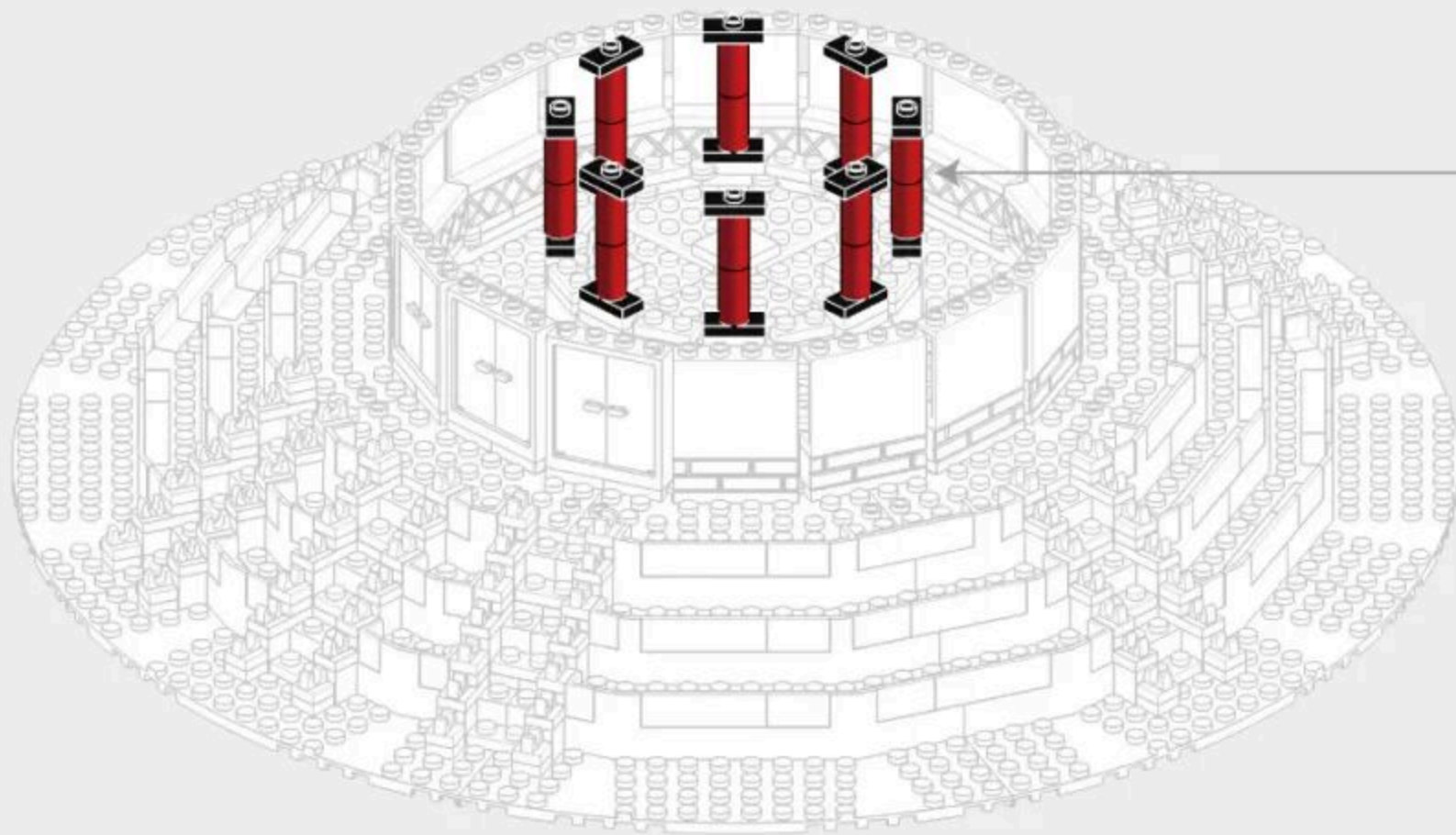

3-8

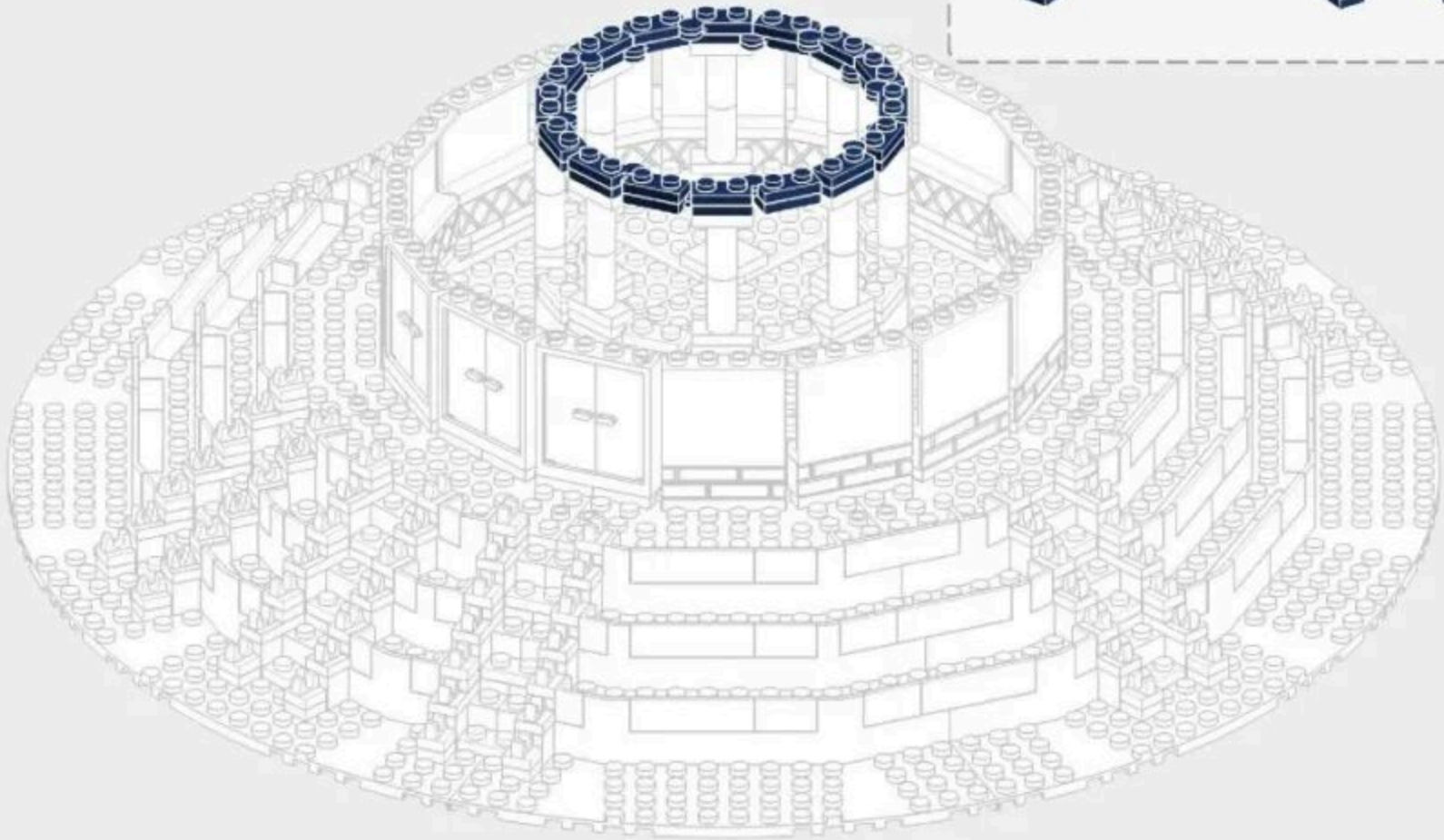
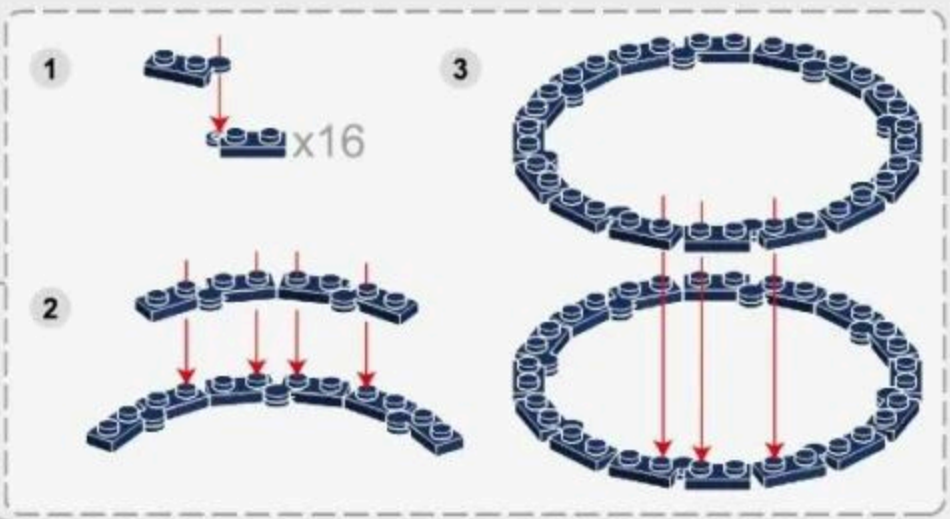

3-9

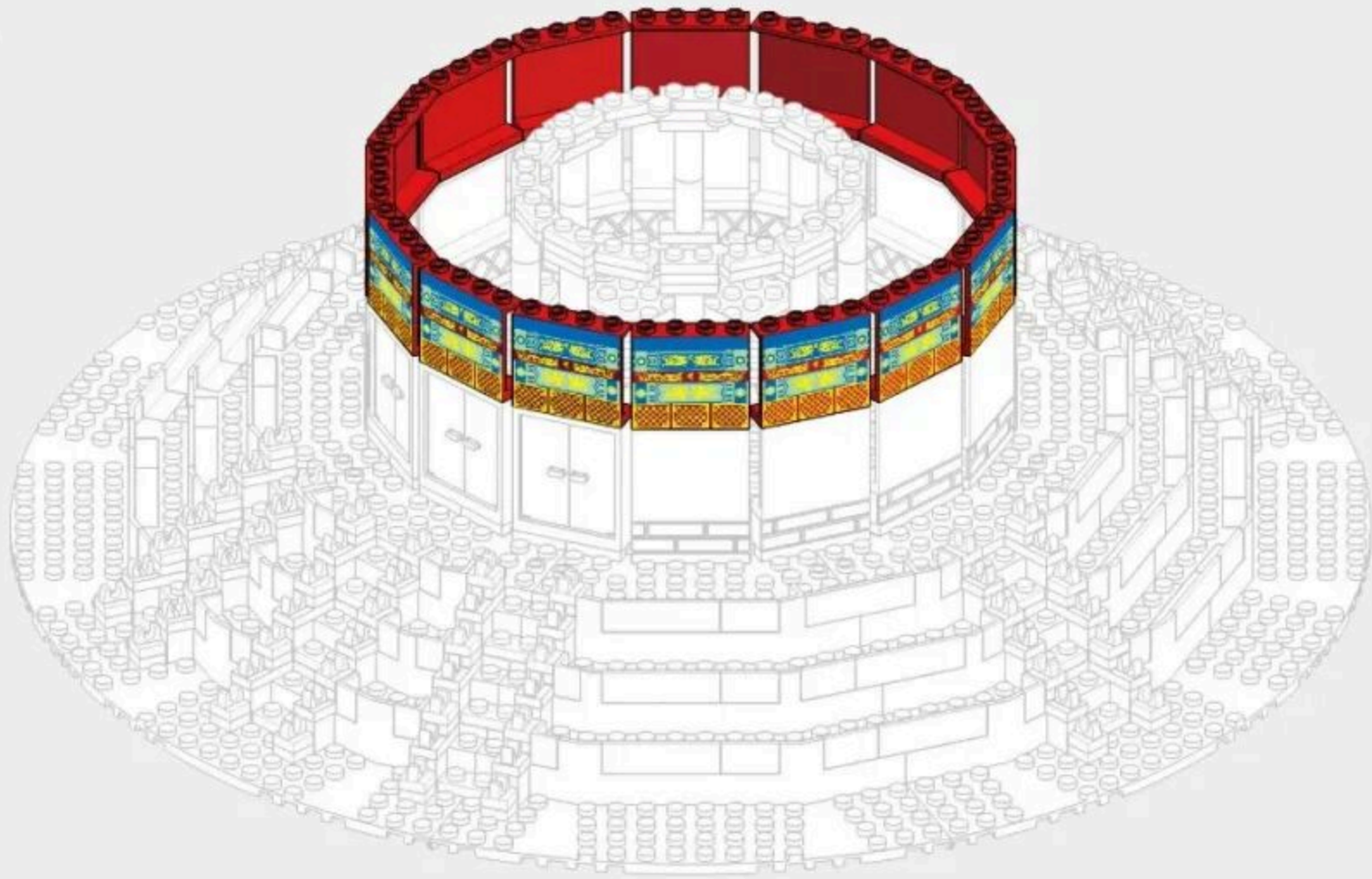

3-10

2x6

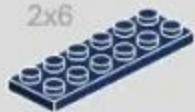

x16

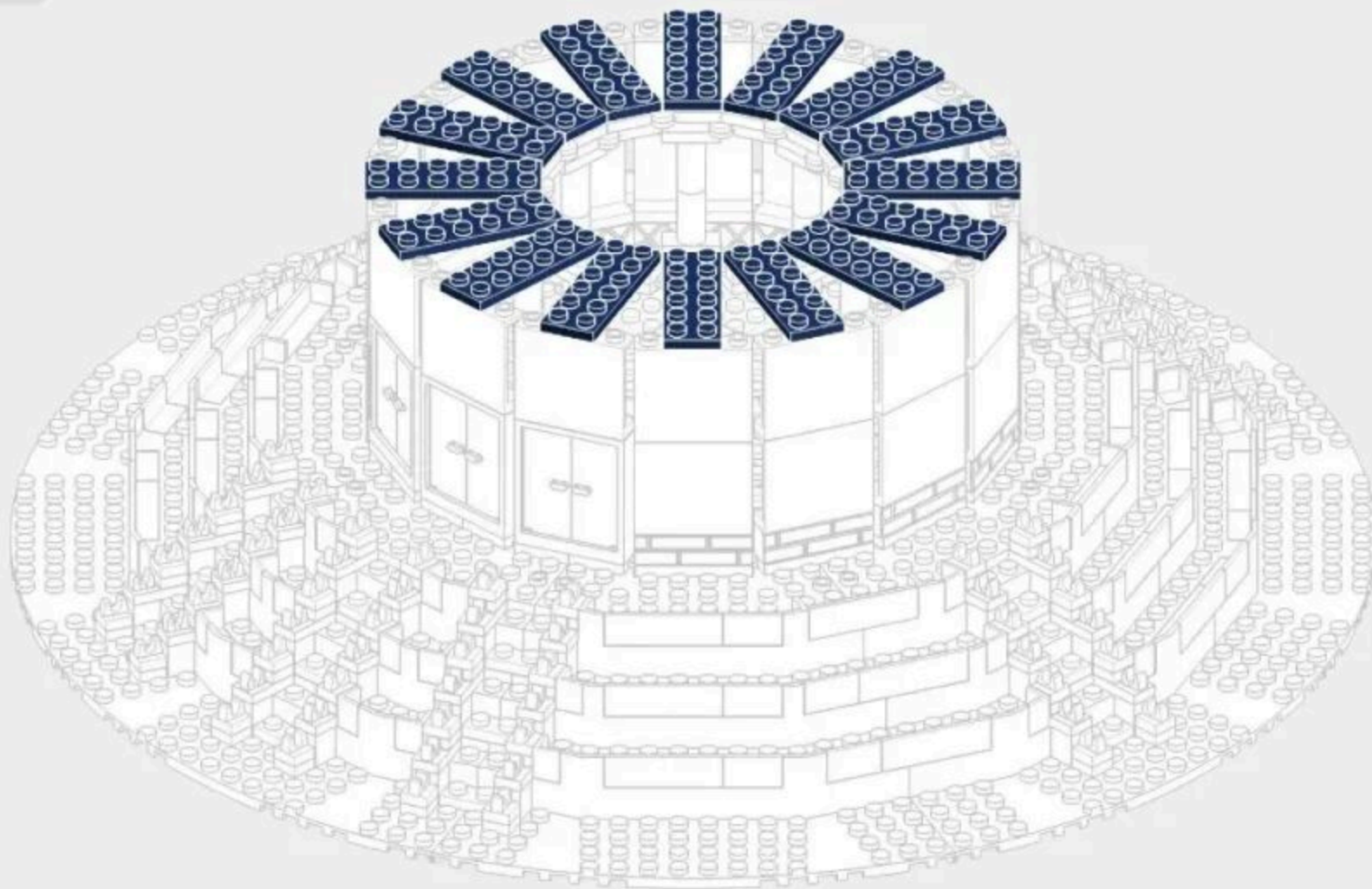



208PCS

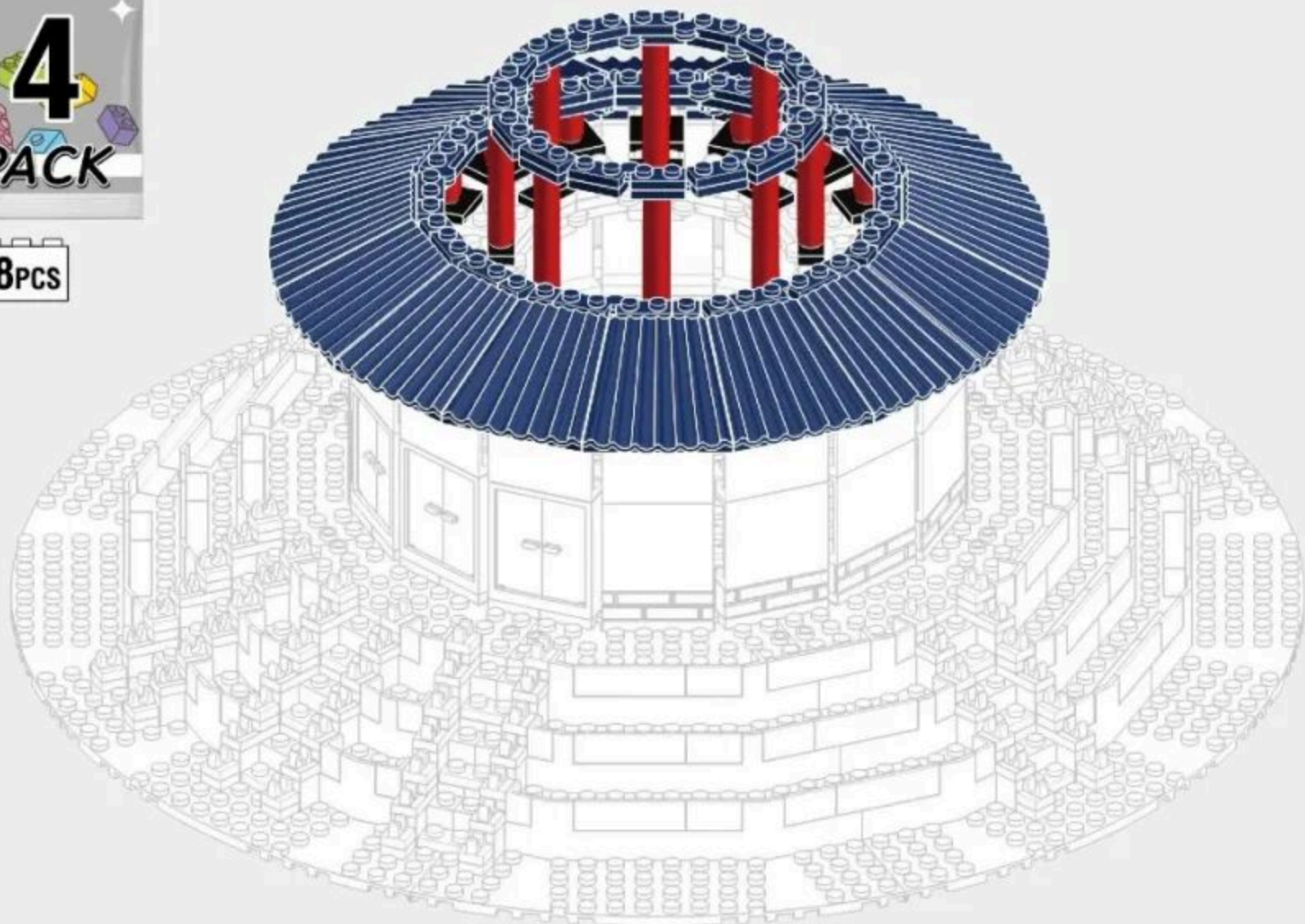

4-1



x32

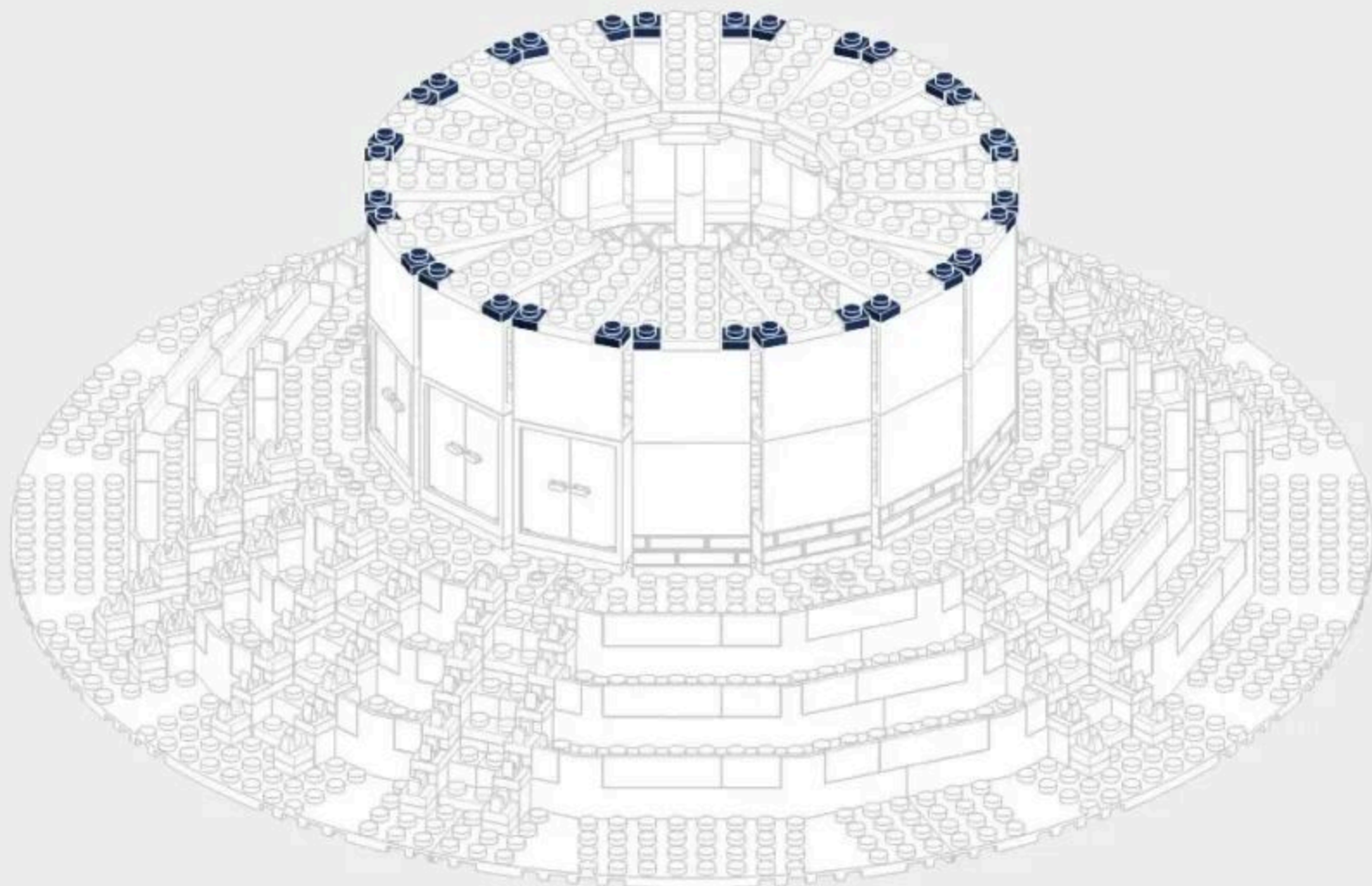

4-2



x16



x16

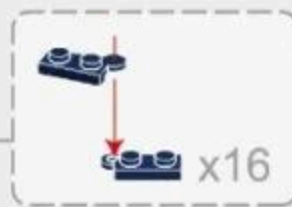
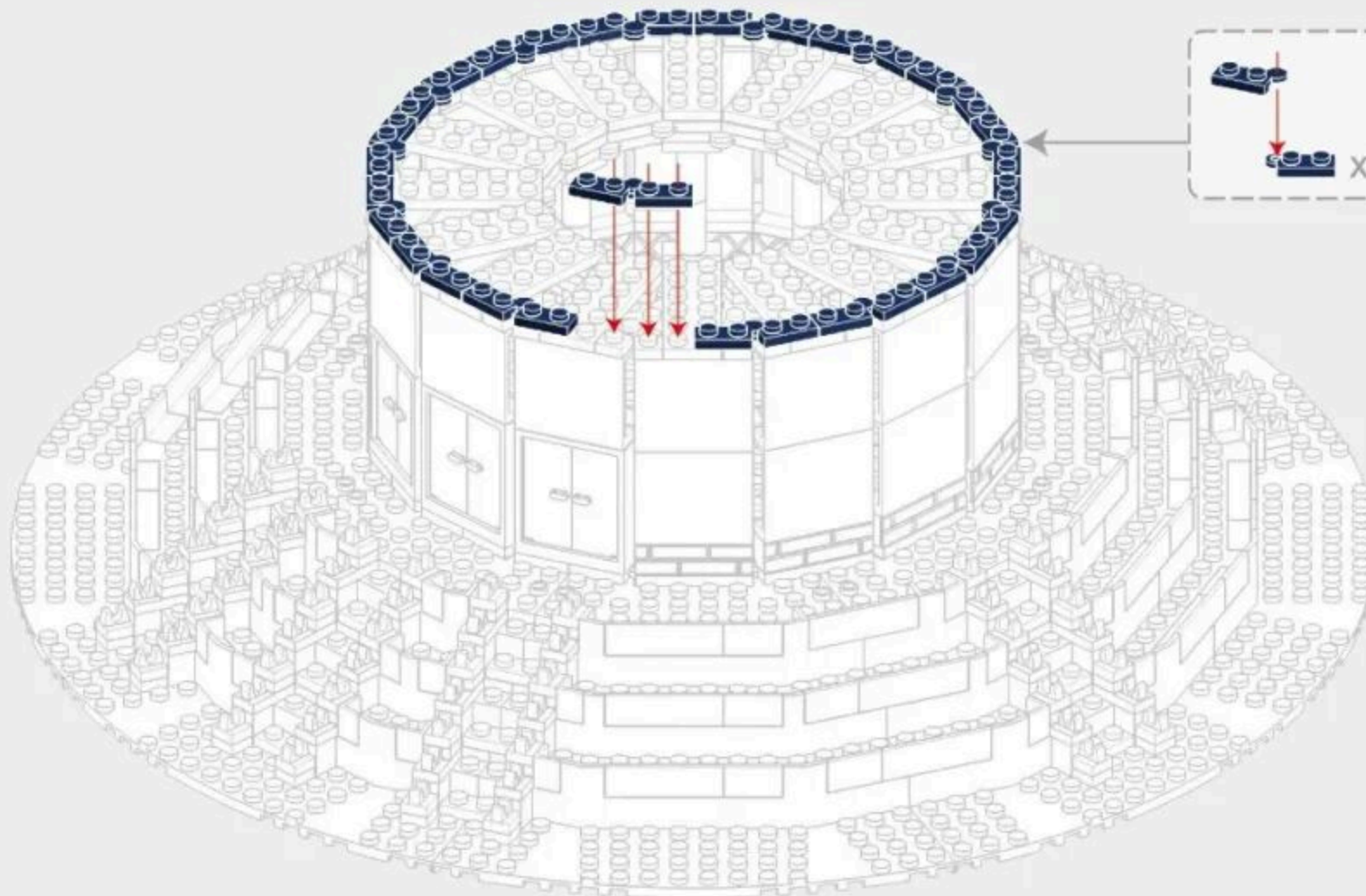

4-3

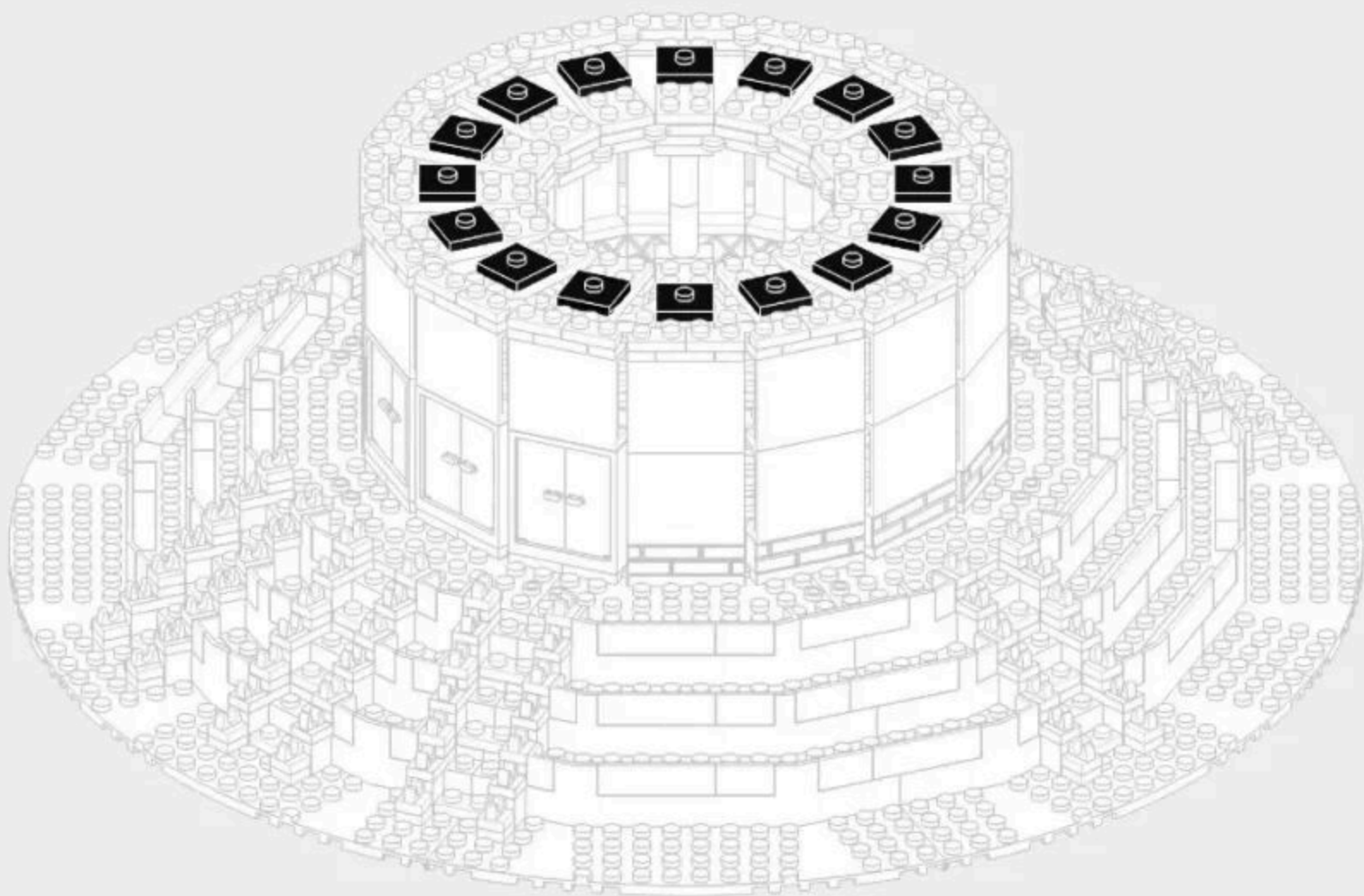

4-4



x16

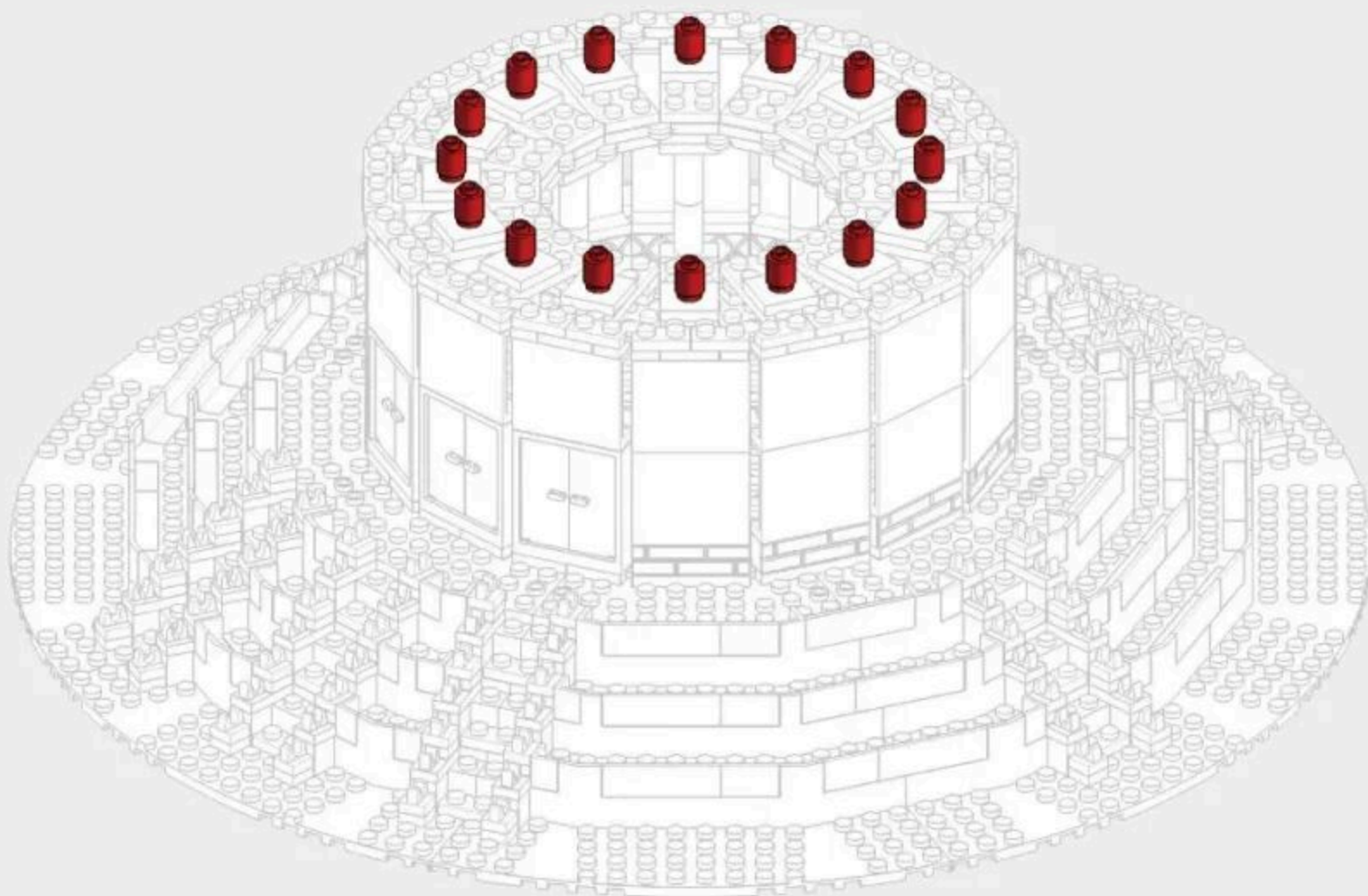

4-5

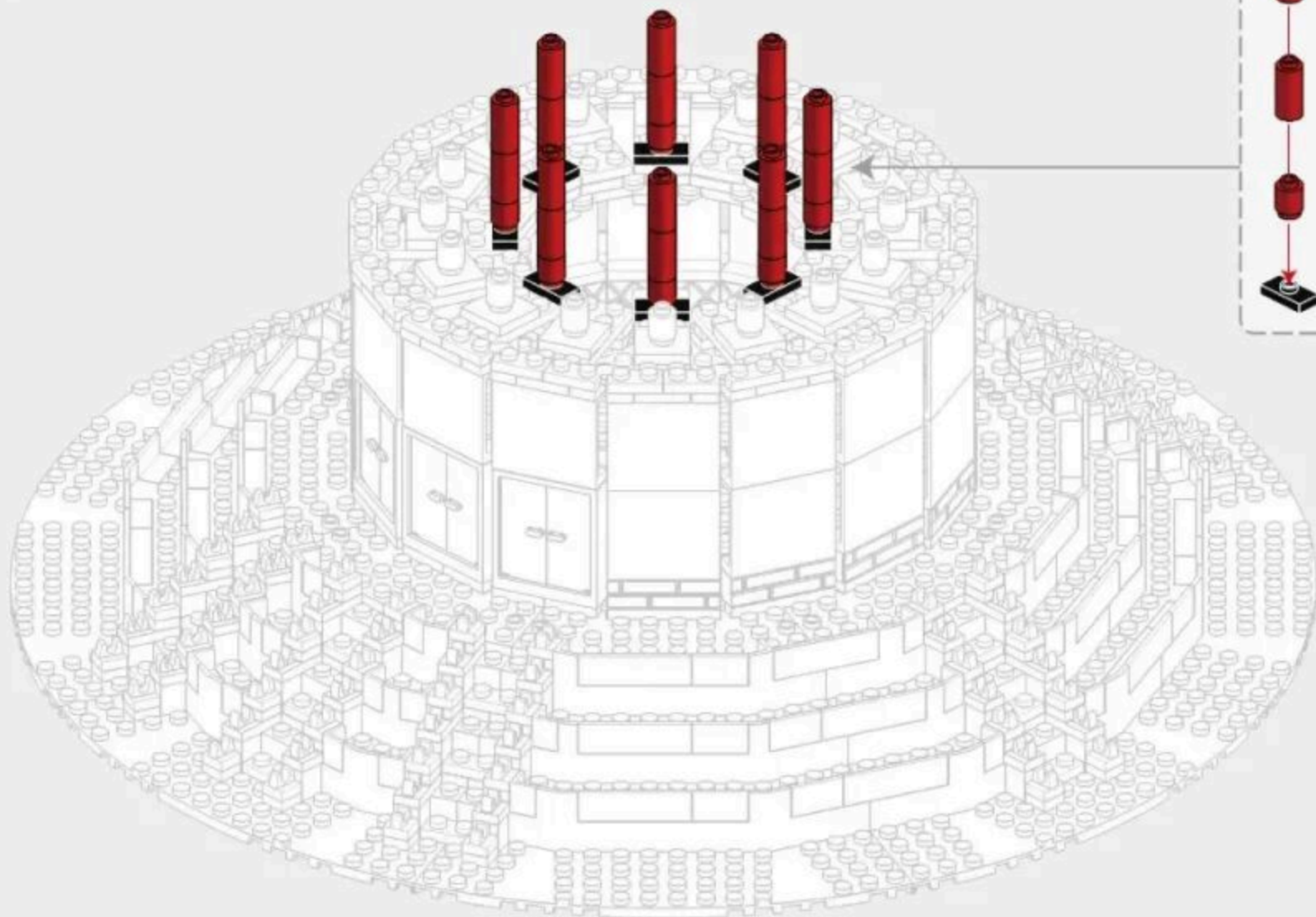

4-6

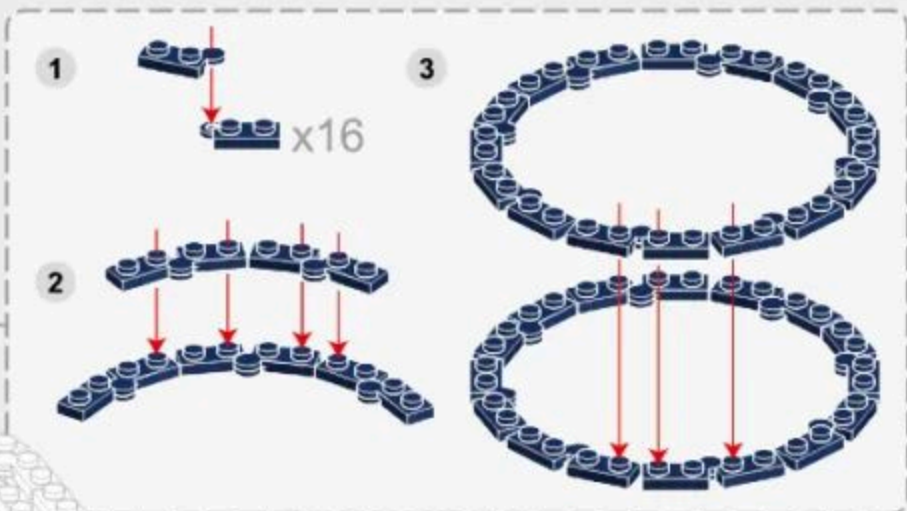
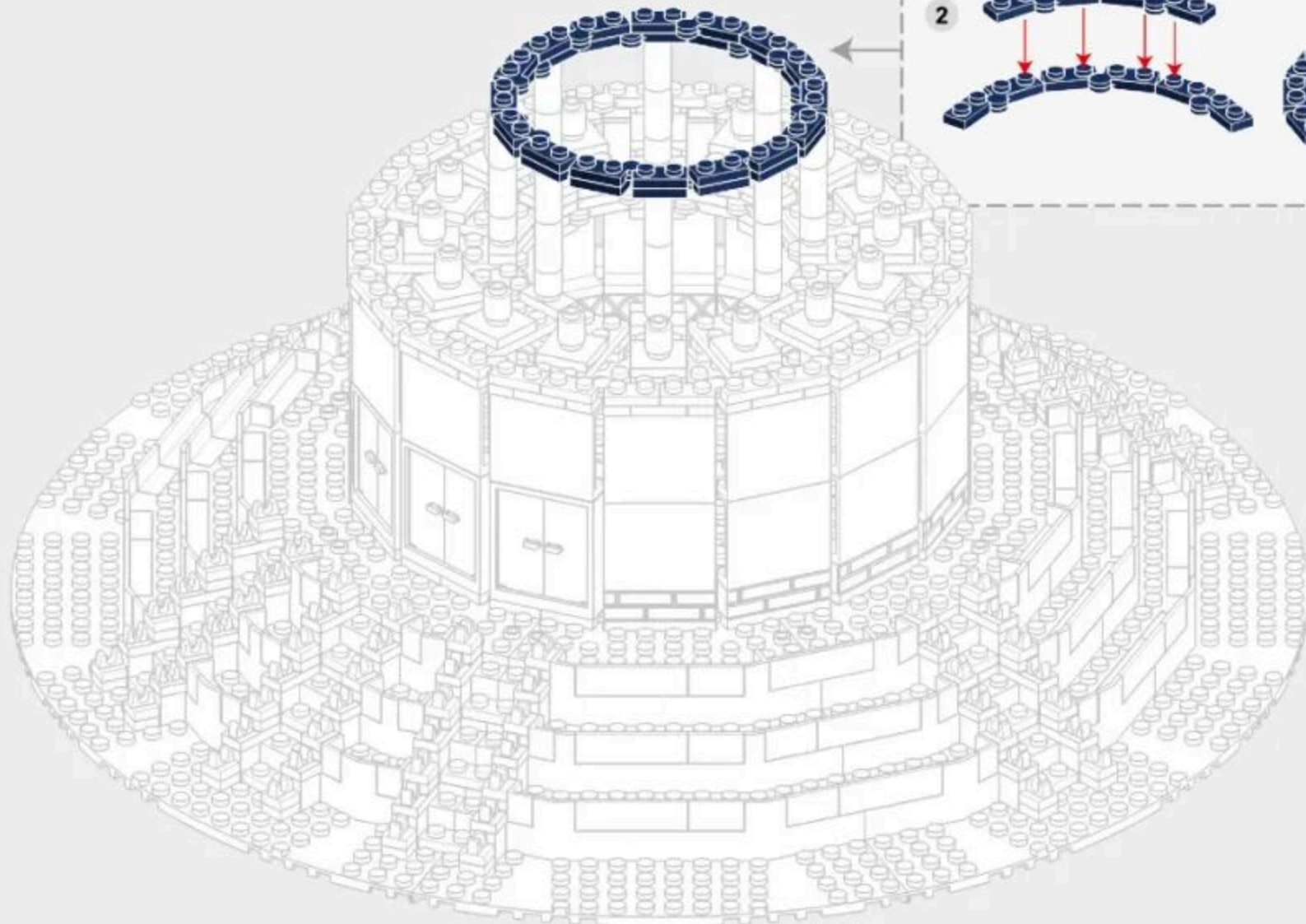

4-7

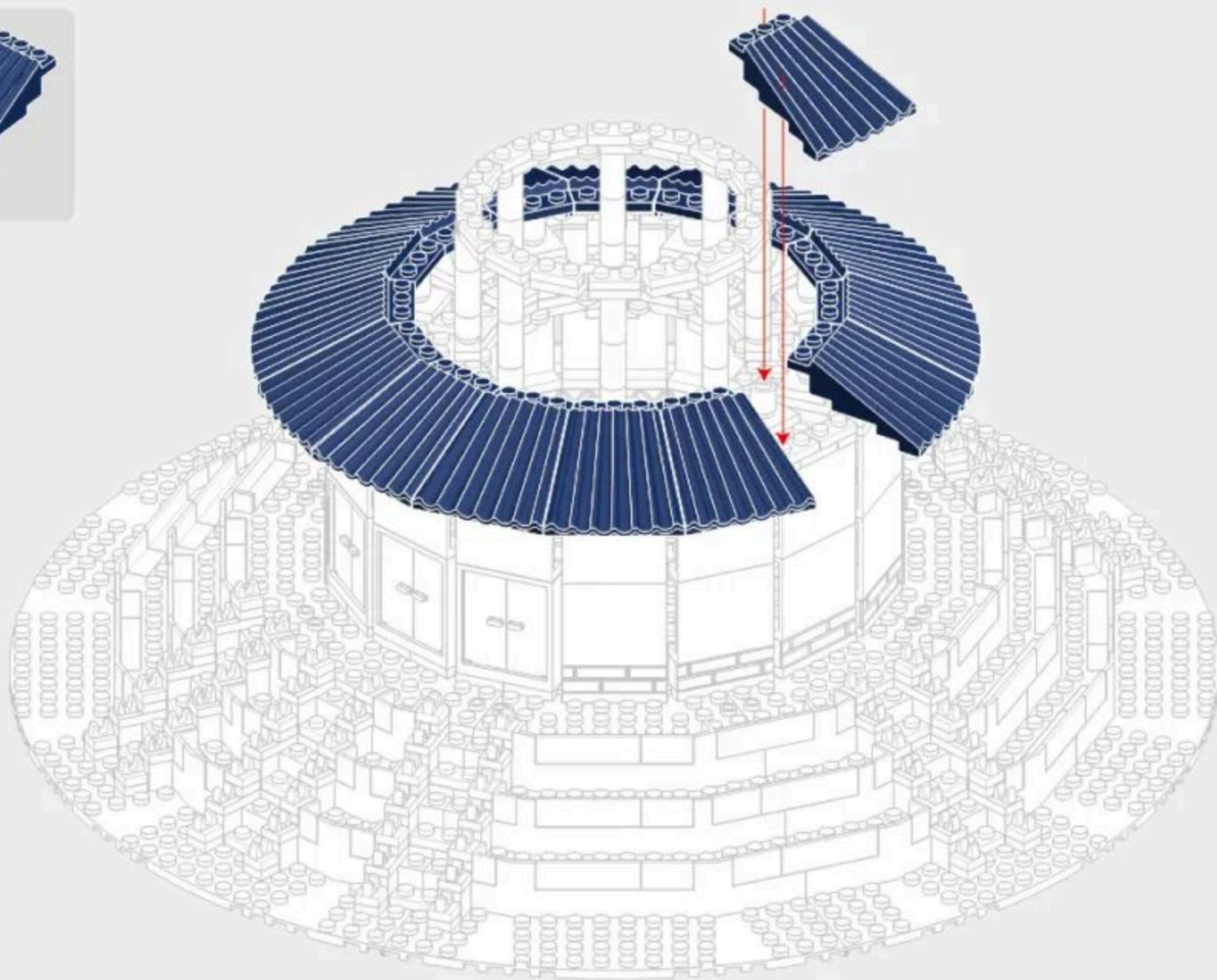

4-8

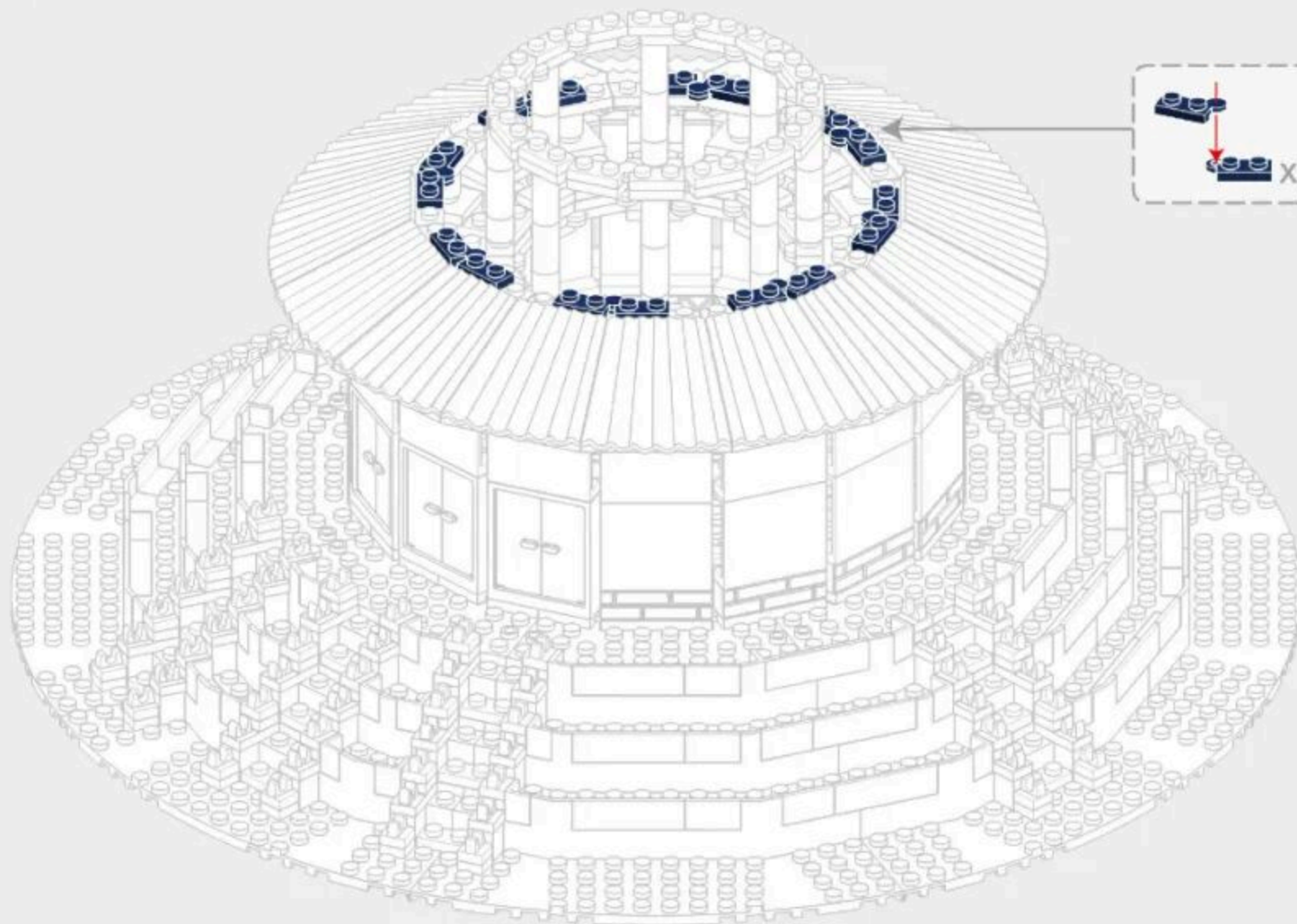

4-9



x16

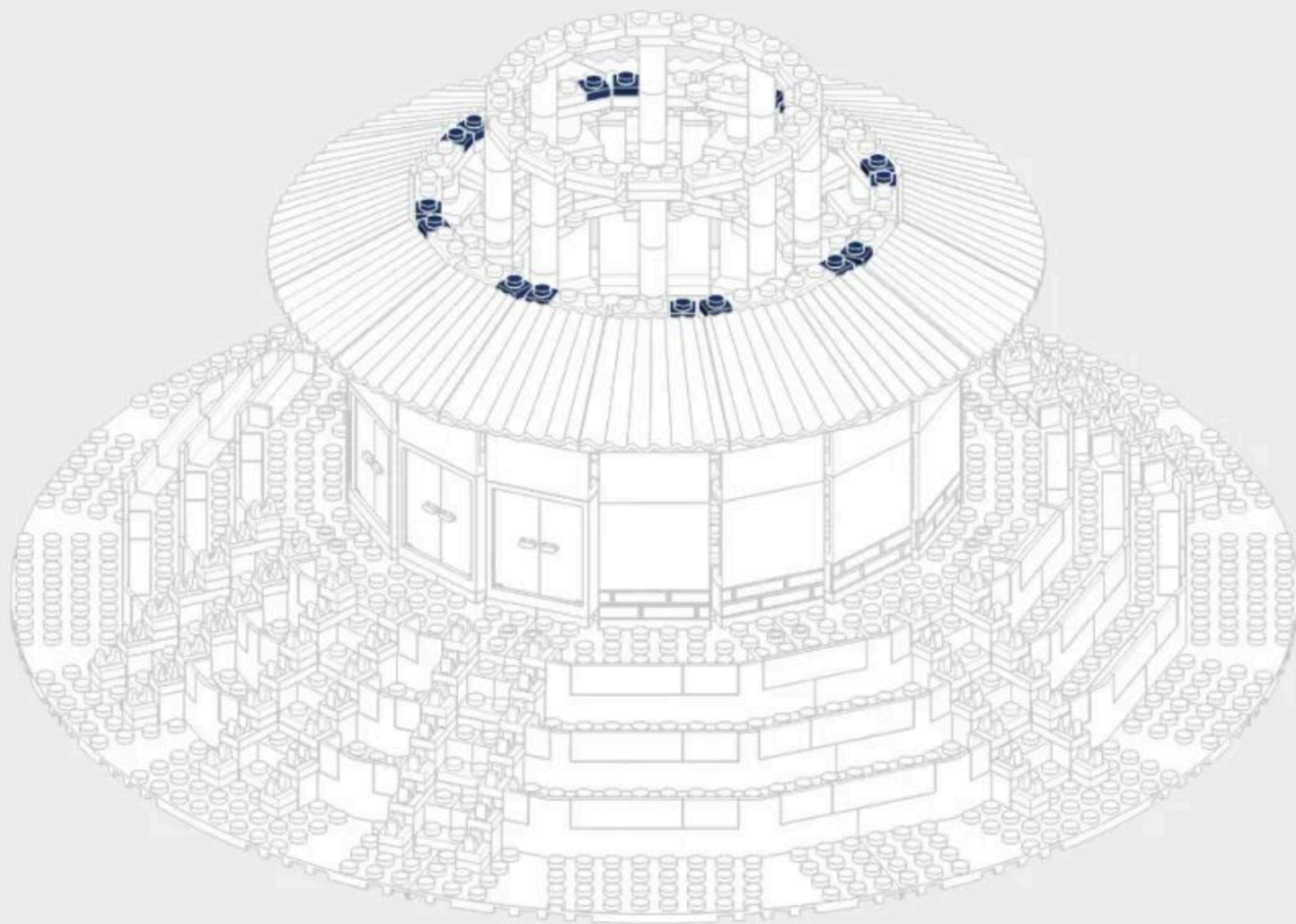



161 PCS

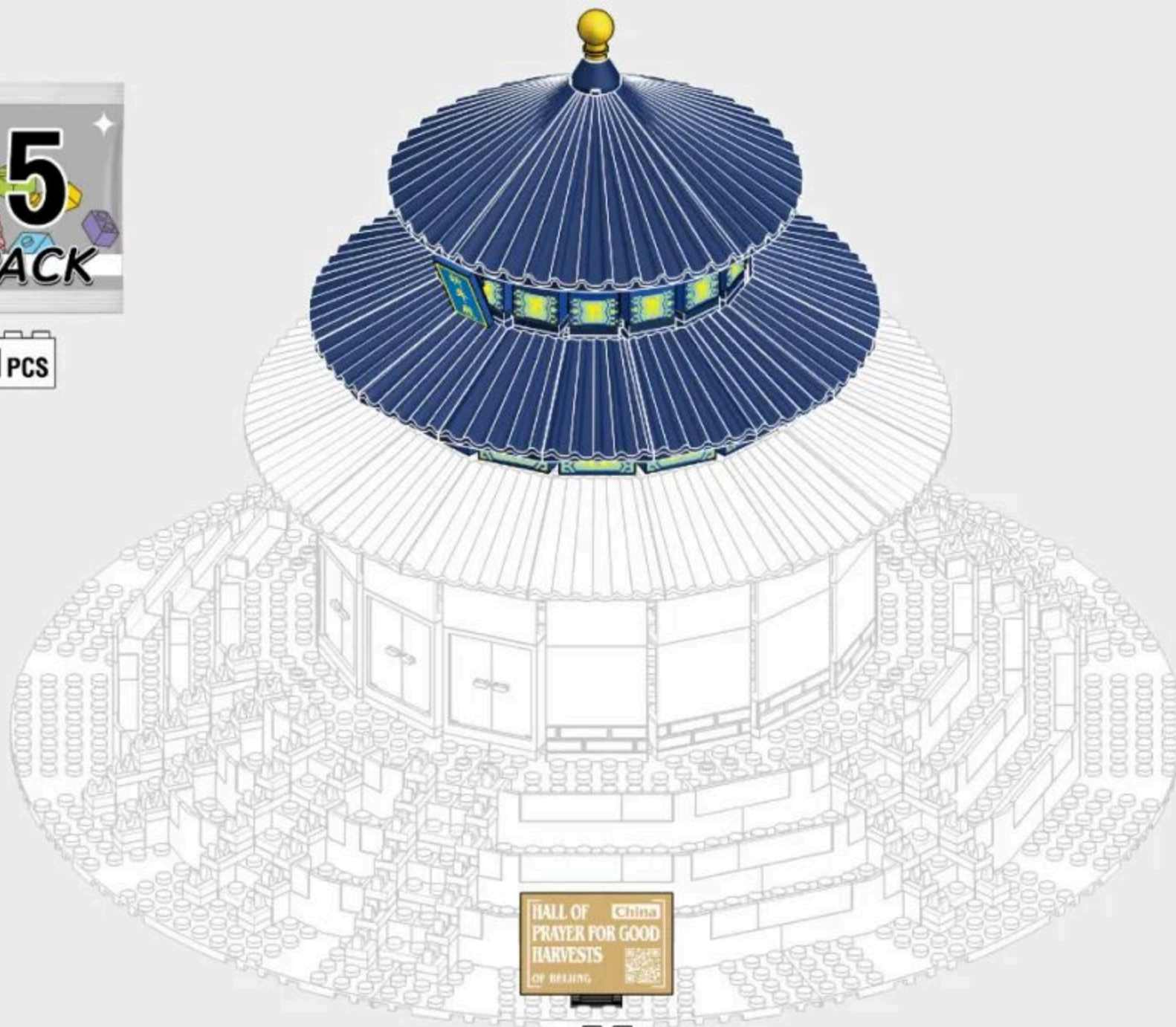

HALL OF PRAYER FOR GOOD HARVESTS OF BEIJING China

55

5-1



x16

x16

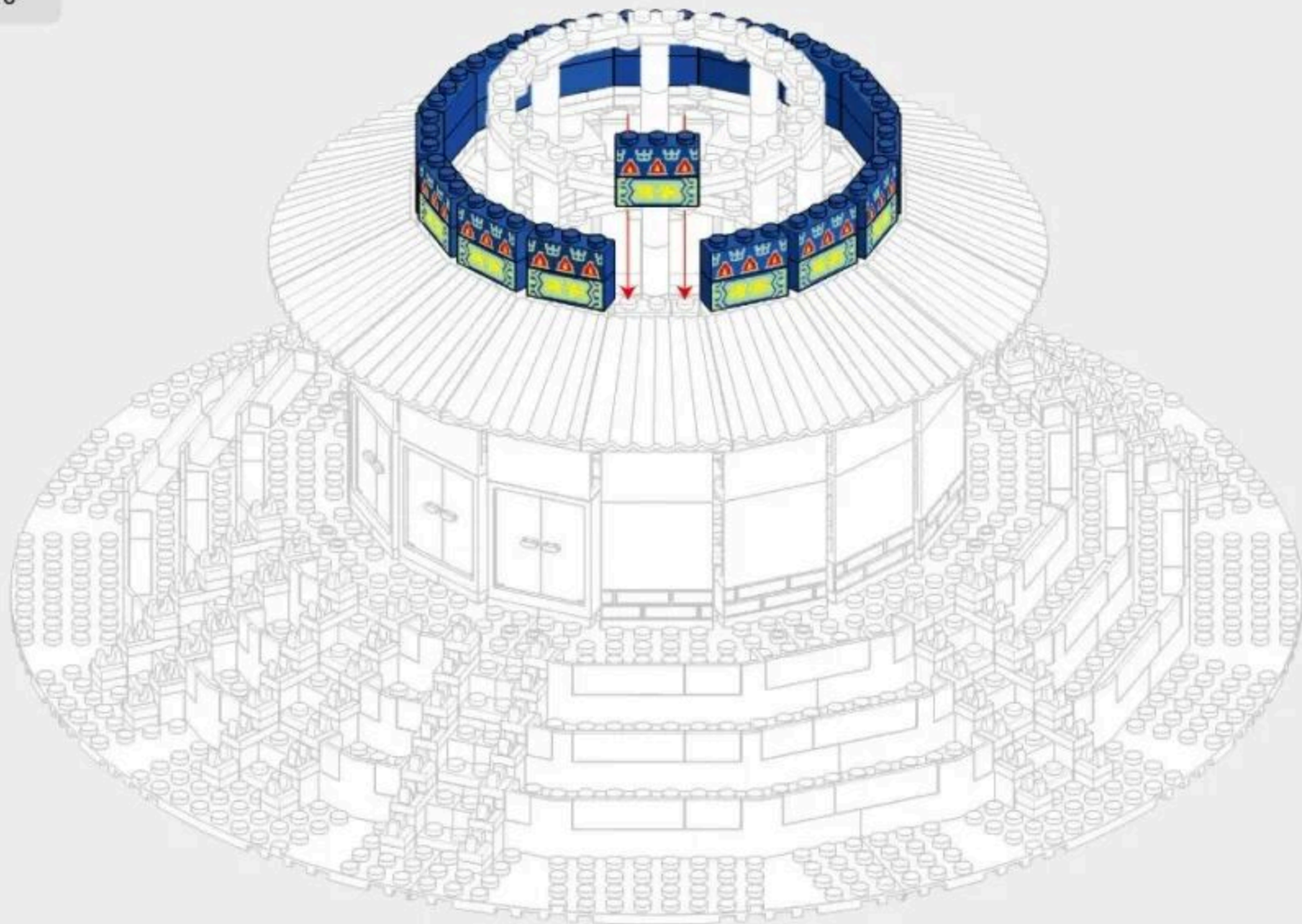

5-2

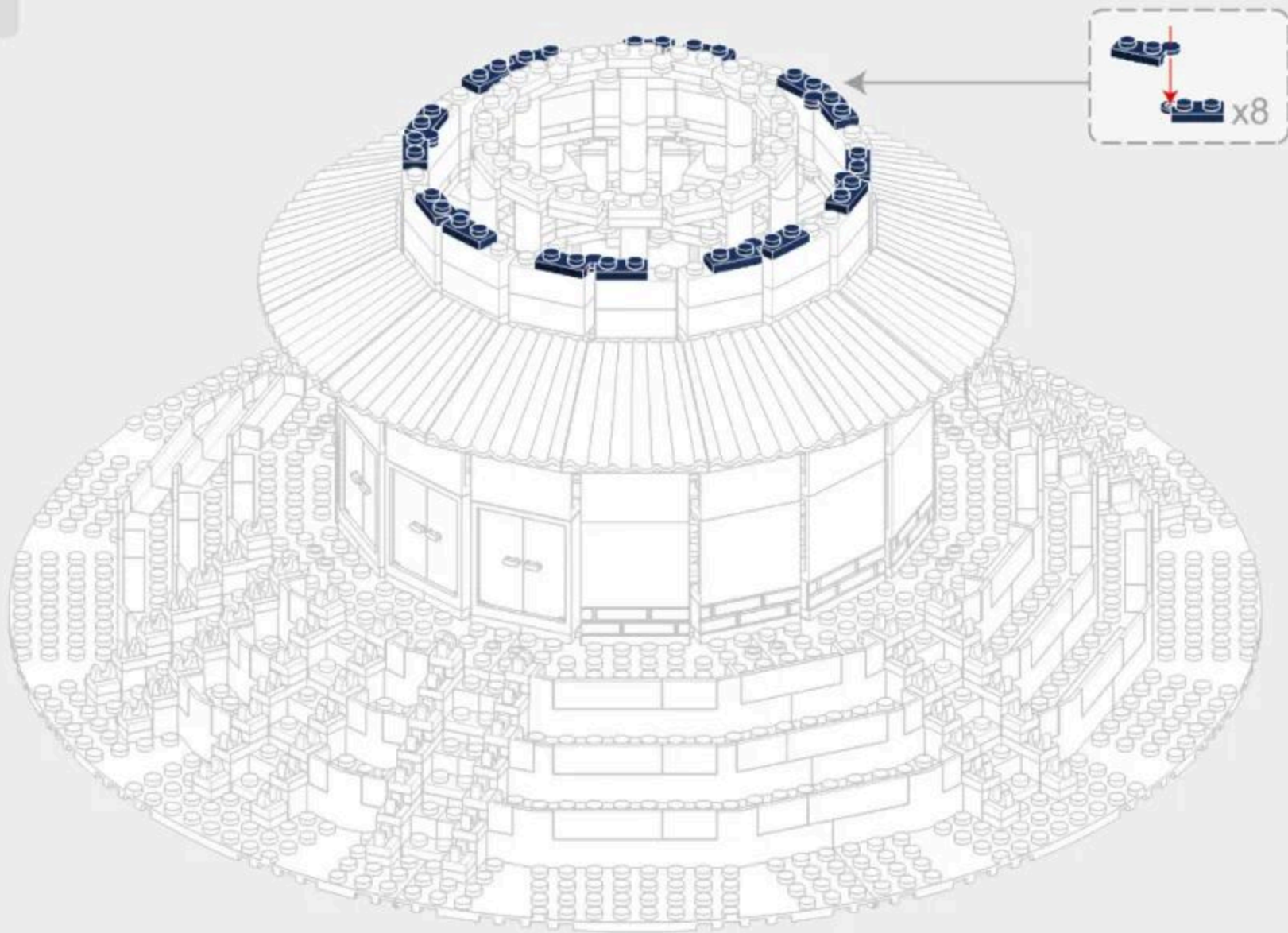

5-3



x16

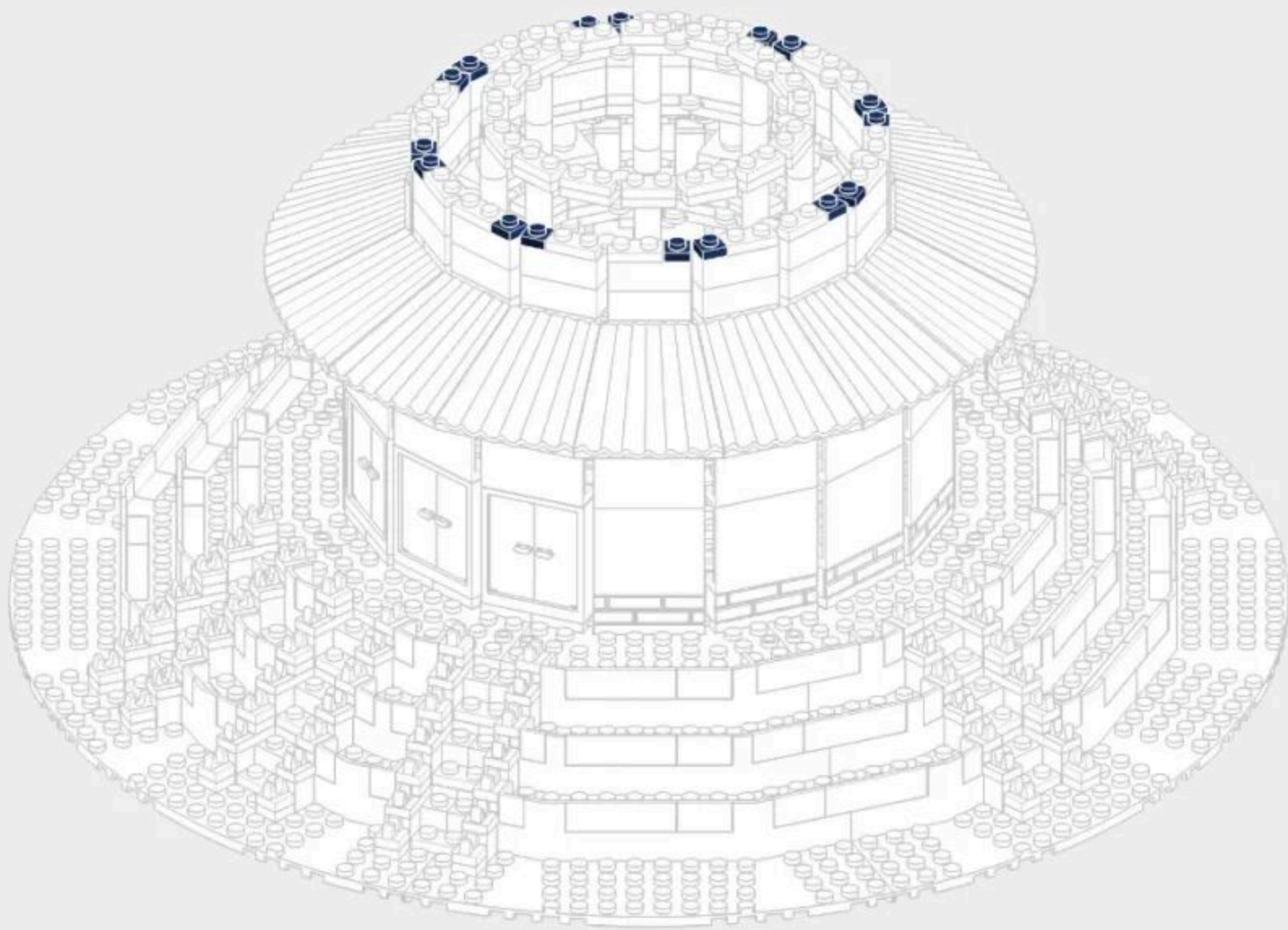

5-4

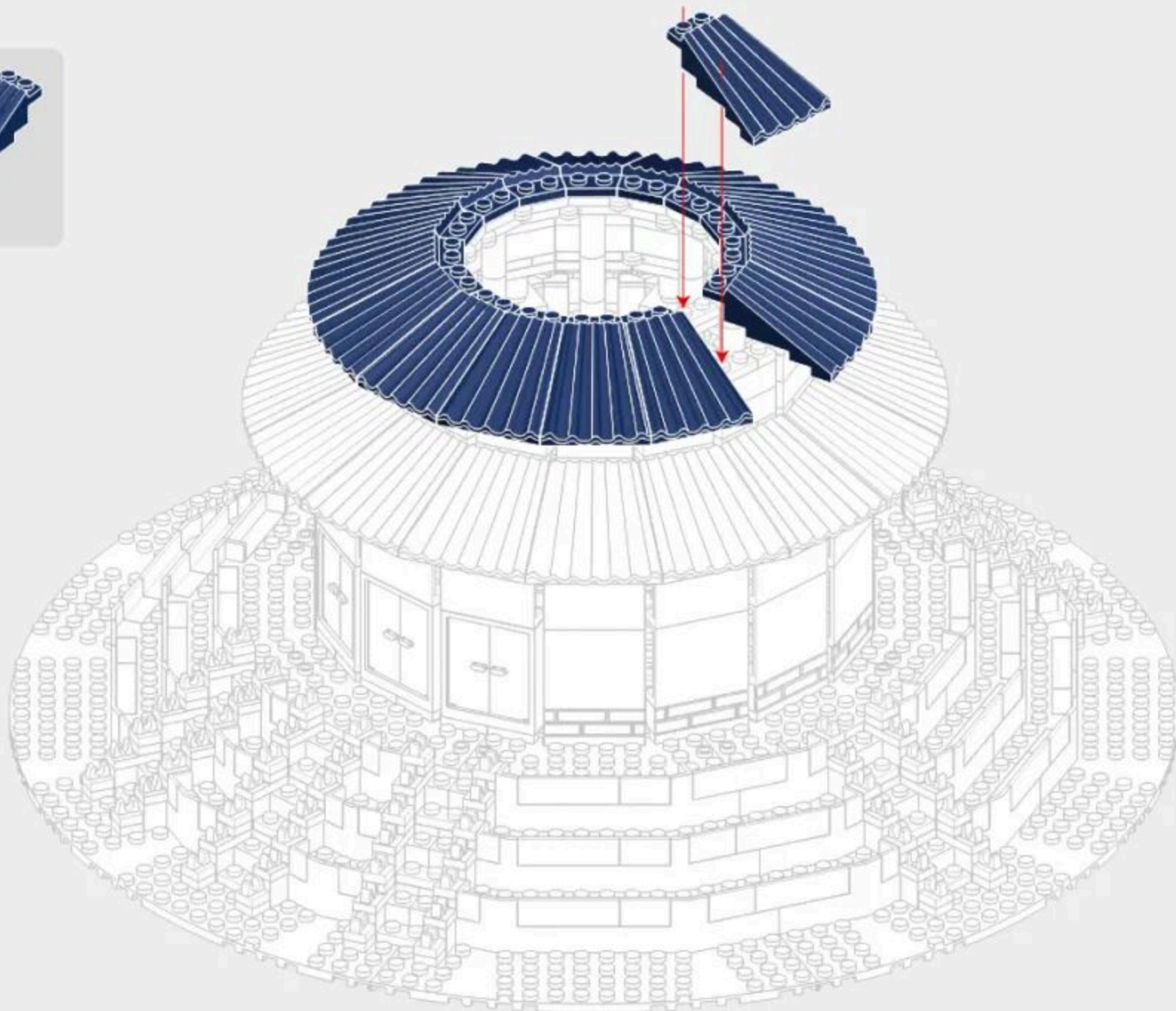

5-5

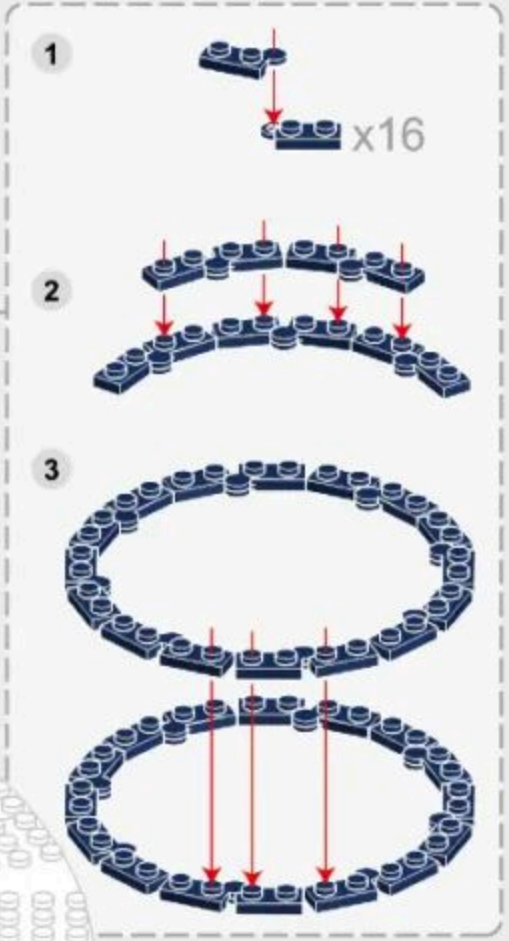
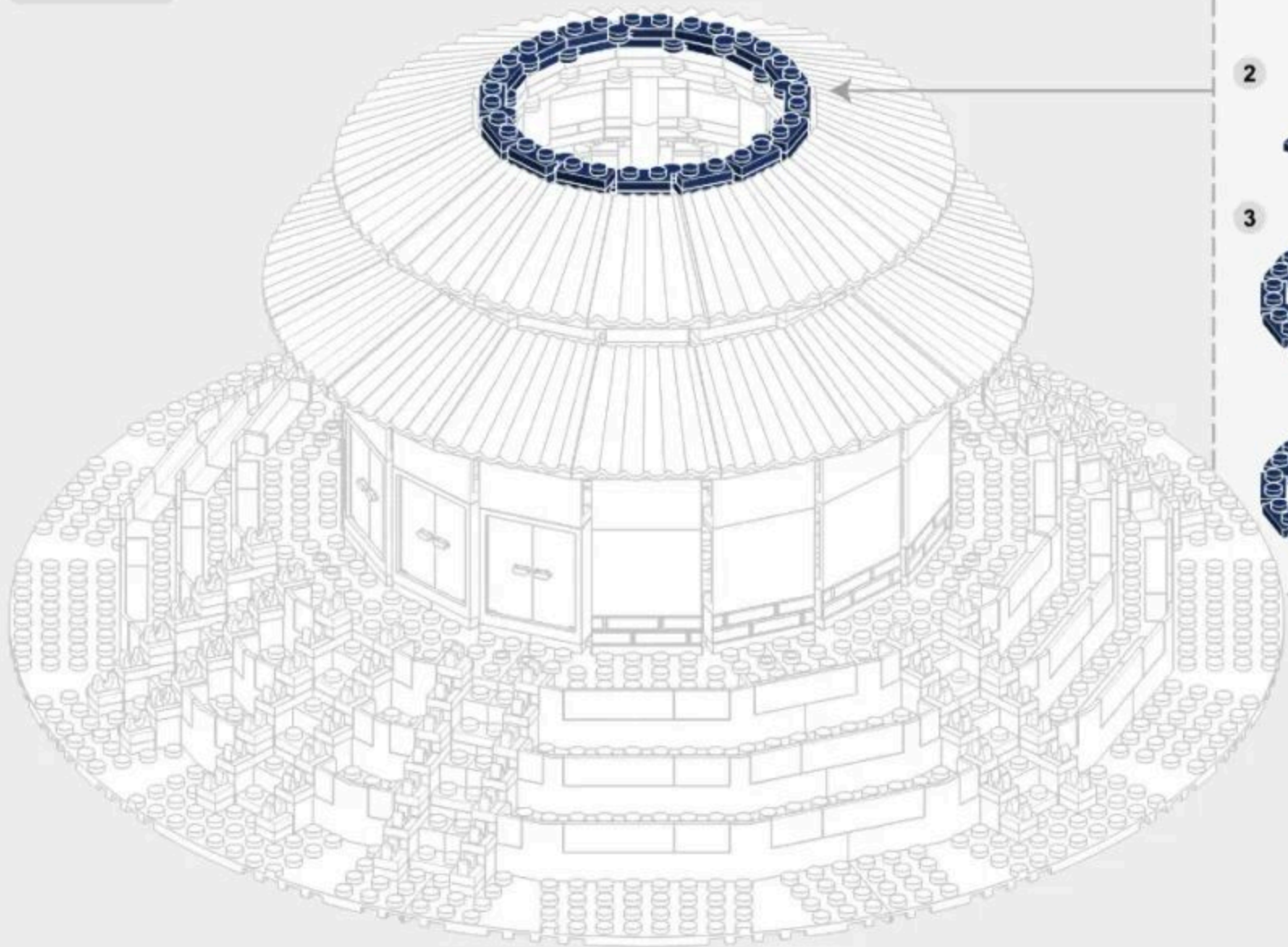

5-6

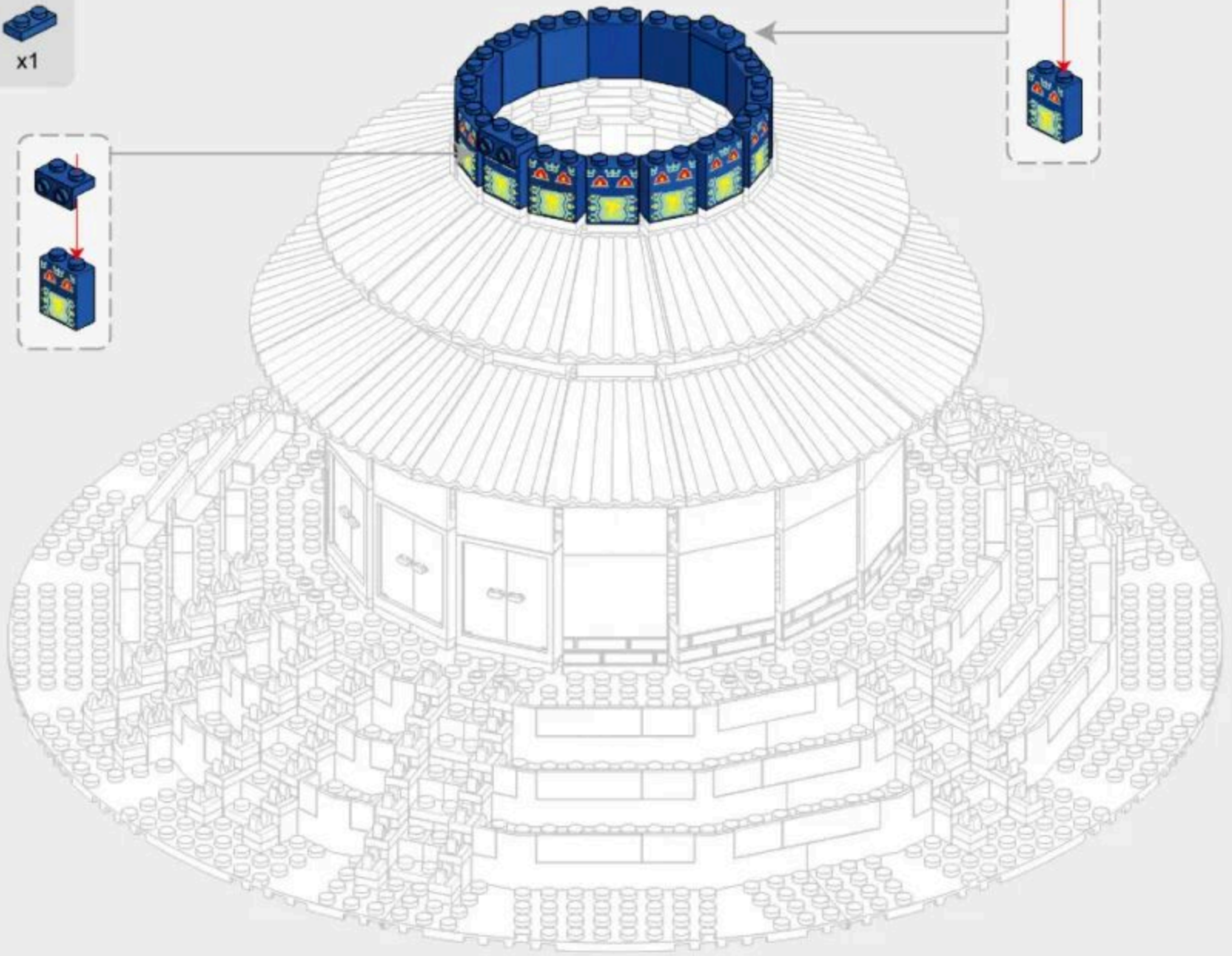
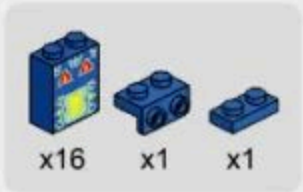

5-7

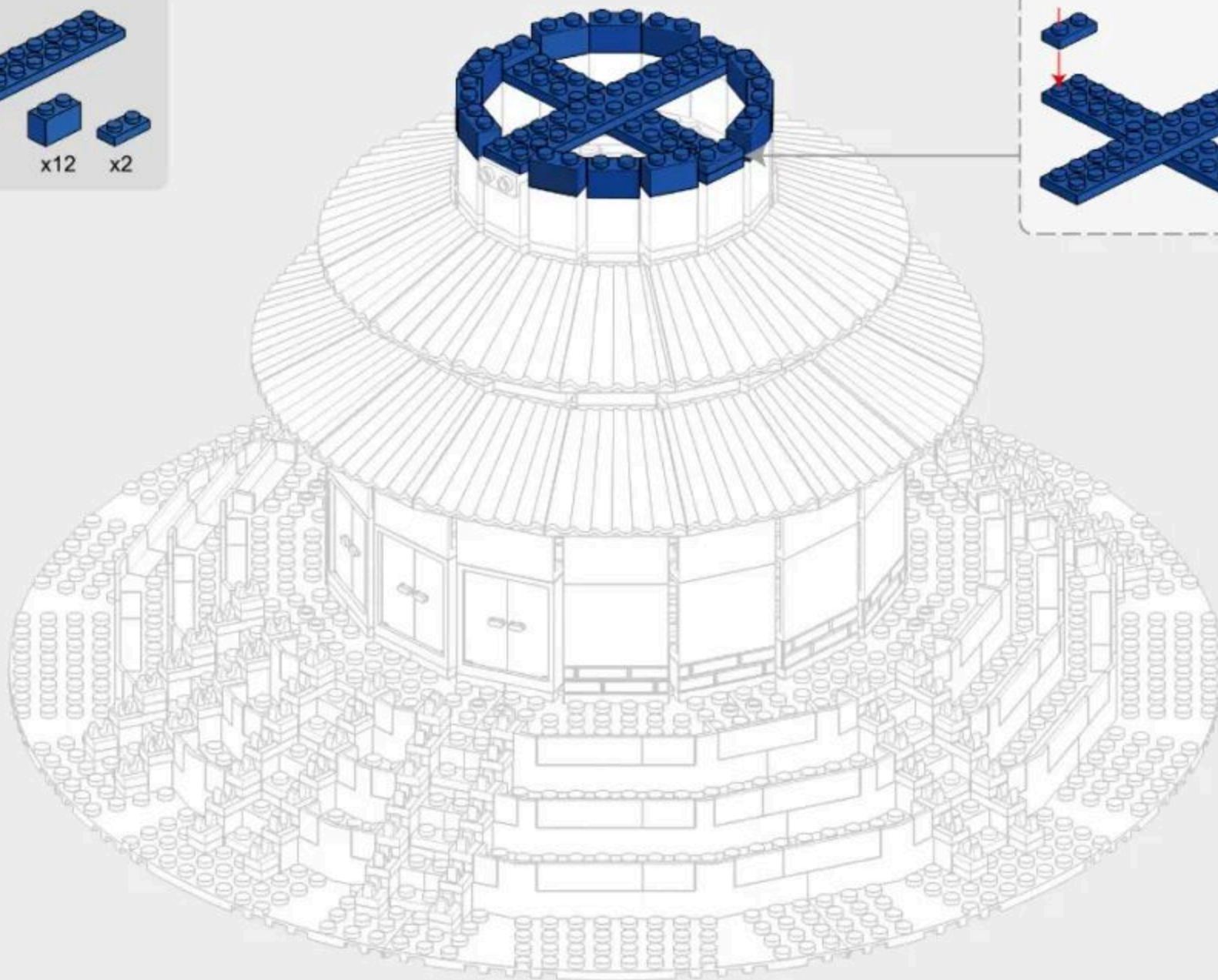
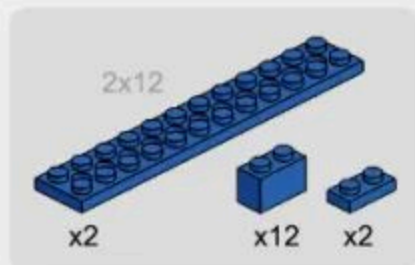

5-8

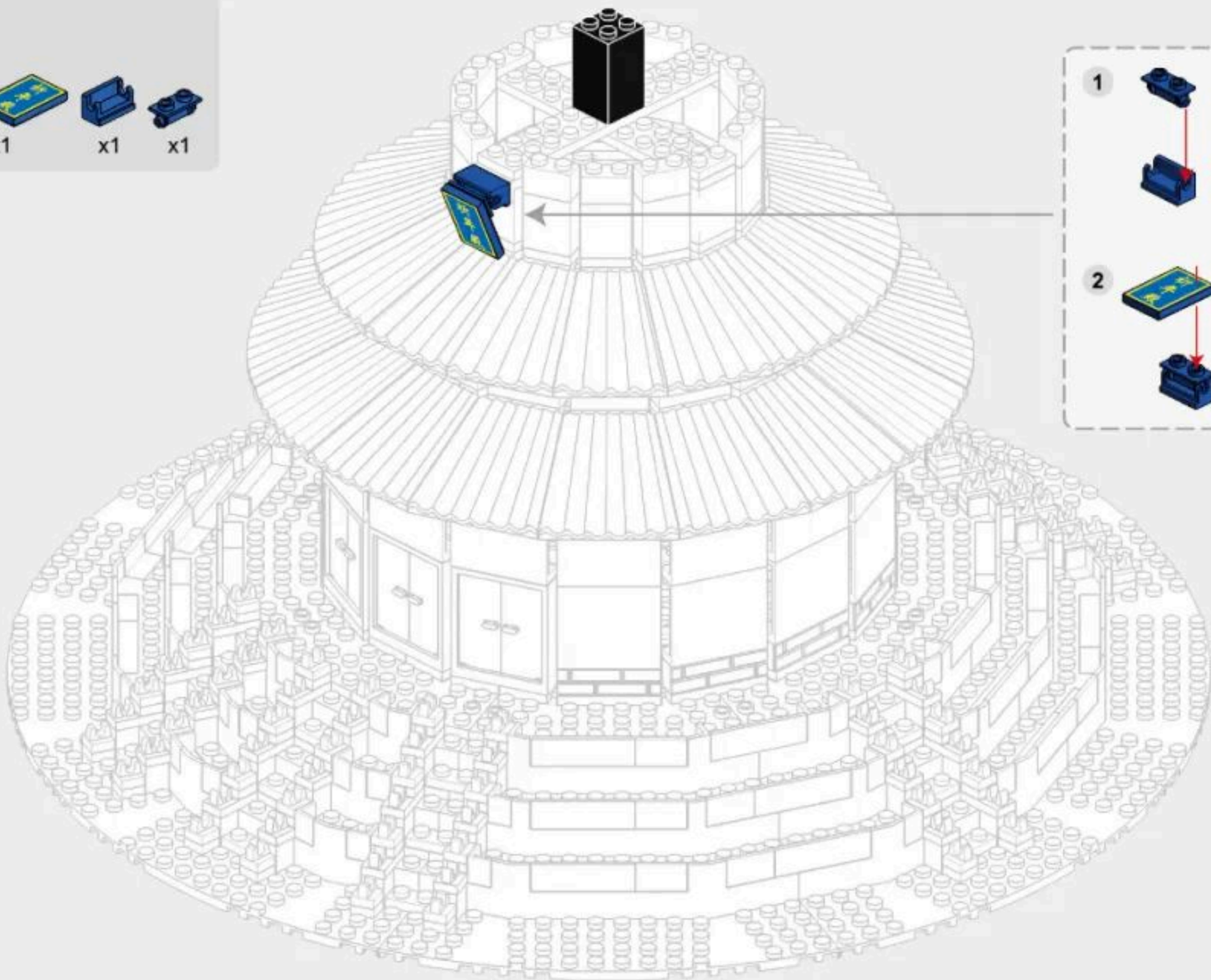
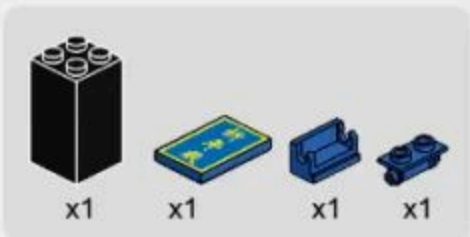

5-9

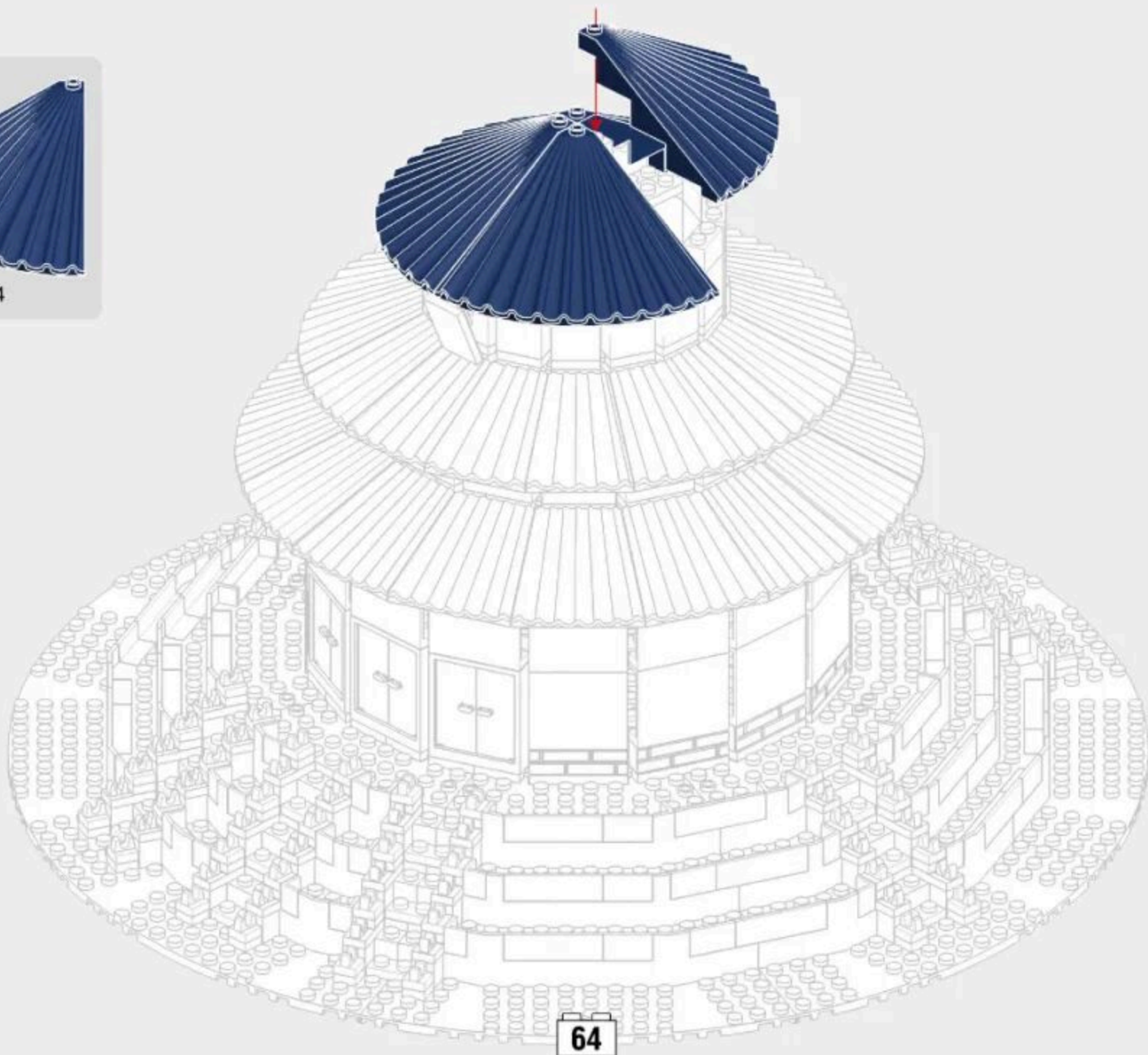

5-10

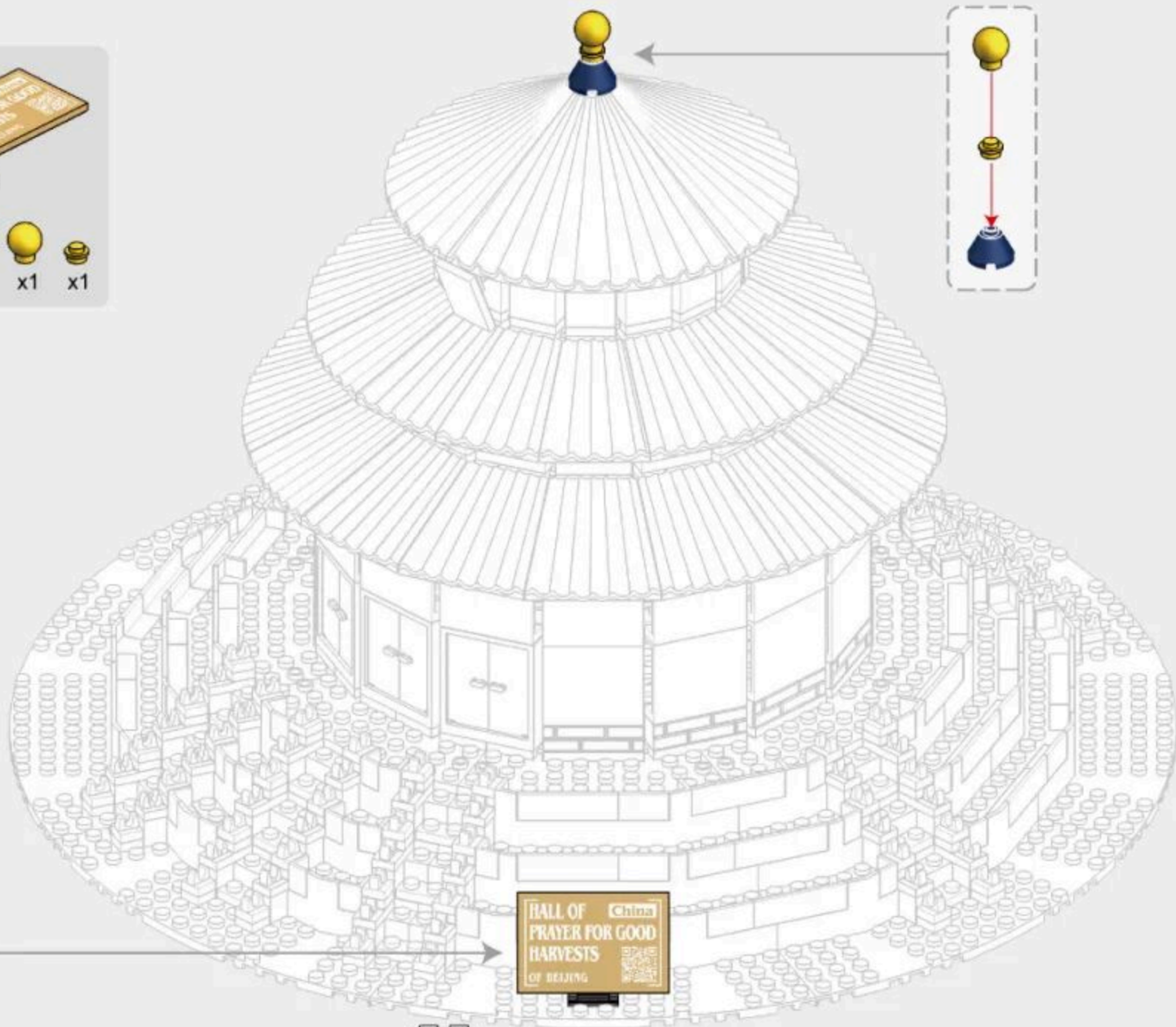
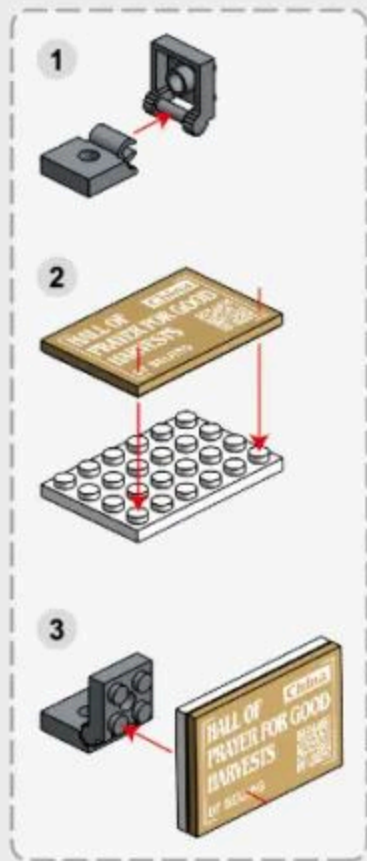
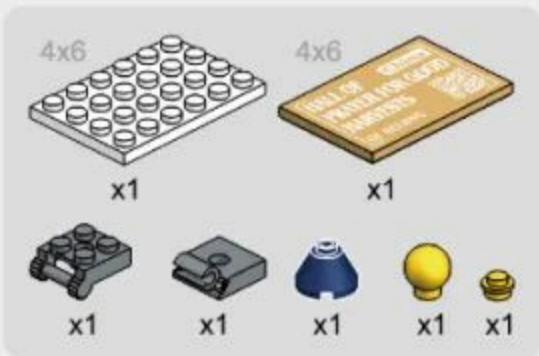

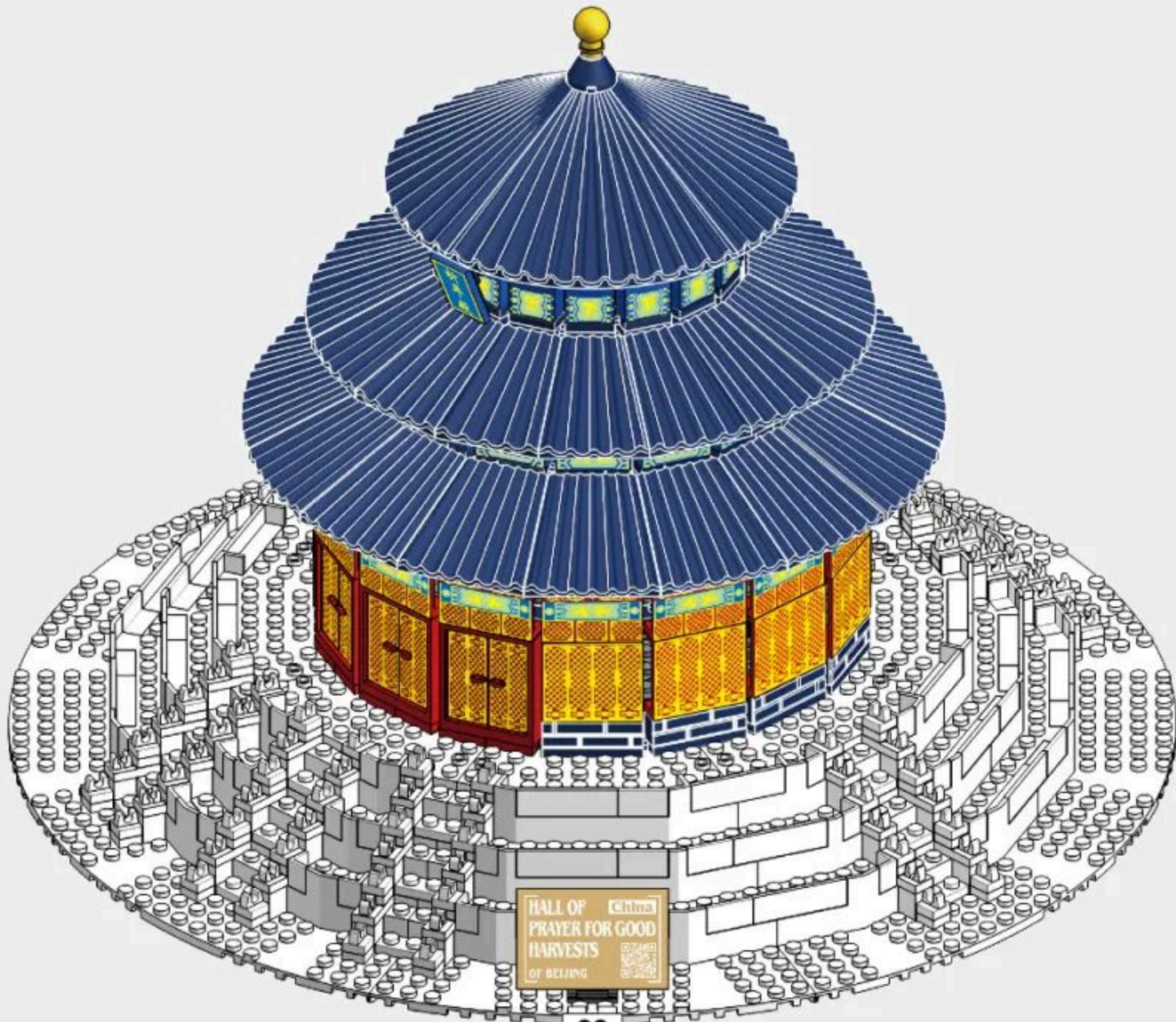

ARCHITECTURE

The World's great architecture

Shaping Skills Imagination & Curiosity Mathematical Self Discovery & Perception Parent-Child Interaction Problem Solving Creativity



6224 英国伦敦白金汉宫
BUCKINGHAM PALACE-LONDON,ENGLAND



5225 意大利罗马斗兽场
COLOSSEUM-ROME,ITALY



5226 日本东京帝国饭店
IMPERIAL HOTEL-TOKYO,JAPAN



5227 美国纽约自由女神像
STATUE OF LIBERTY-NEW YORK,AMERICA



6211 德国柏林勃兰登堡门
BRANDENBURG GATE-BERLIN, GERMANY



6222 中国甘肃长城-嘉峪关
JIAYU PASS-GANSU,CHINA



6212 日本京都清水寺仁王门
NIOMON GATE OF KIYOMIZU-DERA-KYOTO,JAPAN



6213 俄罗斯莫斯科瓦西里大教堂
SAINT BASIL'S CATHEDRAL-MOSCOW,RUSSIA



6214 中国武汉黄鹤楼
YELLOW CRANE TOWER-WUHAN,CHINA



6215 英国伦敦眼
LONDON EYE-LONDON,ENGLAND



6221 中国北京故宫-太和殿
HALL OF SUPREME HARMONY-BEIJING,CHINA



6220 沙特阿拉伯麦加大清真寺
GREAT MOSQUE OF MECCA,SAUDI ARABIA



6219 美国纽约联合国大厦
UNITED NATIONS HEADQUARTERS-NEW YORK,AMERICA



4214 美国华盛顿白宫
WHITE HOUSE-WASHINGTON D.C.,AMERICA



4212 意大利罗马许愿池
TREVI FOUNTAIN-ROME,ITALY



4213 法国巴黎卢浮宫
MUSÉE DU LOUVRE-PARIS,FRANCE



4218 新加坡-鱼尾狮
MERLION,SINGAPORE



4219 英国伦敦双子塔桥
TOWER BRIDGE-LONDON,ENGLAND



4216 美国华盛顿林肯纪念馆
LINCOLN MEMORIAL-WASHINGTON D.C.,AMERICA



4217 新加坡-金沙酒店
MARINA BAY SANDS,SINGAPORE



4210 埃及开罗吉萨金字塔
GREAT PYRAMID OF GIZA-CAIRO,EGYPT



4221 加拿大渥太华国会山庄
PARLIAMENT BUILDINGS-OTTAWA,CANADA



4211 英国伦敦伊丽莎白塔
ELIZABETH TOWER-ENGLAND



4215 加拿大多伦多电视塔
THE CN TOWER-CANADA



4220 美国纽约熨斗大厦
FLATIRON BUILDING-NEW YORK,AMERICA



4222 阿联酋迪拜哈利法塔 THE BURJ KHALIFA TOWER-DUBAI, UAE
 5224 中国上海东方明珠广播电视塔 ORIENTAL PEARL TOWER-SHANGHAI, CHINA
 5212 美国纽约帝国大厦 EMPIRE STATE BUILDING-NEW YORK, AMERICA
 5213 马来西亚吉隆坡石油双塔 PETRONAS TWIN TOWERS-KUALA LUMPUR, MALAYSIA
 5214 意大利托斯卡纳比萨斜塔 LEANING TOWER OF PISA-TUSCANY, ITALY
 5216 英国伦敦伊丽莎白塔 ELIZABETH TOWER-LONDON, ENGLAND



5219 俄罗斯莫斯科克里姆林宫钟楼 SPASSKAYA TOWER-MOSCOW, RUSSIA
 5220 阿联酋迪拜卓美亚帆船酒店 BURJ AL ARAB HOTEL-DUBAI, UAE
 5217 法国巴黎埃菲尔铁塔 EIFFEL TOWER-PARIS, FRANCE
 5221 中国台北101大楼 TAIPEI 101-TAIPEI, CHINA
 5228 美国芝加哥威利斯大厦 WILLIS TOWER-CHICAGO, AMERICA
 5231 巴西里约热内卢救世基督像 CRISTO REDENTOR-RIO DE JANEIRO, BRASIL



6223 中国武汉长江大桥 WUHAN YANGTZE RIVER BRIDGE
 5210 法国巴黎圣母院大教堂 CATHÉDRALE NOTRE DAME DE PARIS-PARIS, FRANCE
 5211 印度阿格拉泰姬陵 TAJ MAHAL-AGRA, INDIA
 5223 法国巴黎凯旋门 ARC DE TRIOMPHE-PARIS, FRANCE
 5215 英国伦敦双子塔桥 TOWER BRIDGE-LONDON, ENGLAND



5222 中国北京天坛祈年殿 HALL OF PRAYER FOR GOOD HARVESTS-BEIJING, CHINA
 6210 美国旧金山金门大桥 GOLDEN GATE BRIDGE-SAN FRANCISCO, AMERICA
 6216 中国北京万里长城(八达岭) THE GREAT WALL-BEIJING, CHINA
 5218 中国北京天安门 TIANANMEN TOWER-BEIJING, CHINA
 6217 中国西藏布达拉宫 POTALA PALACE-TIBET, CHINA



6218 芬兰罗瓦涅米圣诞老人办公室 SANTA CLAUS OFFICE-ROVANIEMI, FINLAND
 6225 墨西哥库库尔坎玛雅金字塔 EL CASTILLO-KUKULKAN, MEXICO
 6226 德国巴伐利亚新天鹅堡 SCHLOSS NEUSCHWANSTEIN-BAYERN, DEUTSCHLAND
 5229 土耳其伊斯坦布尔少女塔 MAIDEN TOWER-ISTANBUL, TURKEY
 5230 中国湖南长沙爱晚亭 AIWANTING PAVILION-HUNAN, CHINA



7210 中国上海世博会中国馆
CHINA PAVILION AT EXPO-SHANGHAI, CHINA



5232 美国宾夕法尼亚州流水别墅
FALLINGWATER-PENNSYLVANIA, AMERICA



5233 美国芝加哥范斯沃斯住宅
FARNSWORTH HOUSE-CHICAGO, AMERICA



5234 美国华盛顿唐人街
CHINA TOWN-WASHINGTON, D.C., AMERICA



3210 美国纽约自由女神像
STATUE OF LIBERTY-NEW YORK, AMERICA



4223 中国北京清华园
TSINGHUA CAMPUS-BEIJING, CHINA



7211 中国湖南岳阳楼
YUEYANG TOWER-HUNAN, CHINA



8210 澳大利亚悉尼歌剧院
SYDNEY OPERA HOUSE-BENNELONG POINT, AUSTRALIA



7212 中国江西南昌滕王阁
PAVILION OF PRINCE TENG-JIANGXI, CHINA



6227 中国河南郑州嵩山少林寺
SHAOLIN TEMPLE-HENAN, CHINA



7213 中国重庆洪崖洞
HONGYADONG-CHONGQING, CHINA



5235 美国华盛顿国会大厦
UNITED STATES CAPITOL-WASHINGTON D.C., AMERICA



5236 中国安徽滁州醉翁亭
ZUIWENG PAVILION-ANHUI, CHINA



6228 中国陕西西安钟楼
XI'AN BELL TOWER-SHAANXI, CHINA



5238 美国西雅图太空针塔
SPACE NEEDLE-SEATTLE, AMERICA



5237 法国巴黎萨伏伊别墅
VILLA SAVOYE-PARIS, FRANCE



6229 中国山西运城鹳雀楼
STORK TOWER-SHANXI, CHINA



6230 希腊爱情海圣托里尼岛
SANTORINI-FIRA, GREECE



6231 中国上海海关大楼
SHANGHAI CUSTOMS HOUSE-SHANGHAI, CHINA



5239 中国北京紫禁城角楼
TURRET OF PALACE MUSEUM-BEIJING, CHINA



5240 韩国首尔崇礼门
NAMDAEMUN-SEOUL, KOREA



5241 中国江苏南京夫子庙
CONFUCIUS TEMPLE-JIANGSU, CHINA



5242 美国纽约古根海姆博物馆
GUGGENHEIM MUSEUM-NEW YORK, AMERICA



6232 中国江苏南京秦淮河画舫
QINHUAI RIVER PAINTED BOAT-JIANGSU, CHINA



6233 法国诺曼底圣米歇尔山
SAINT MICHAEL'S MOUNT-NORMANDY, FRANCE



6234 中国河南洛阳栾川老君山
THE LAOJUN MOUNTAIN-HENAN, CHINA



5243 耶路撒冷岩石圆顶
DOME OF THE ROCK-JERUSALEM



6235 中国江苏苏州寒山寺 (普明宝塔)
HANSHAN TEMPLE-JIANGSU, CHINA



4224 英国威尔特郡巨石阵
STONEHENGE-WILTSHIRE, ENGLAND



4225 中国内蒙古自治区蒙古包
MONGOLIAN YURT-INNER MONGOLIA, CHINA



8211 中国福建土楼(承启楼)
CHENGQI EARTH BUILDING, CHINA

HALL OF PRAYER FOR GOOD HARVESTS

COUNTRY: China
CITY: Beijing

