



THE COLOSSEUM OF ROME

Italy
The world's great architecture

Ages
6+



NO.5225
1758 PCS

Perseverance

积木匠心·颗粒匠者



The Temple of Heaven



The Eiffel Tower



The Brandenburg Gate



The Leaning Tower Of Pisa



The Taj Mahal



The Big Ben



The White House



The Burj Al-Arab Hotel



The Golden Gate Bridge



The CN Tower



The Spasskaya Tower



The Triumphal Arch





It will be a city...

这将构成一座城市...

Architecture

Structure

剖析结构与实物数据比例

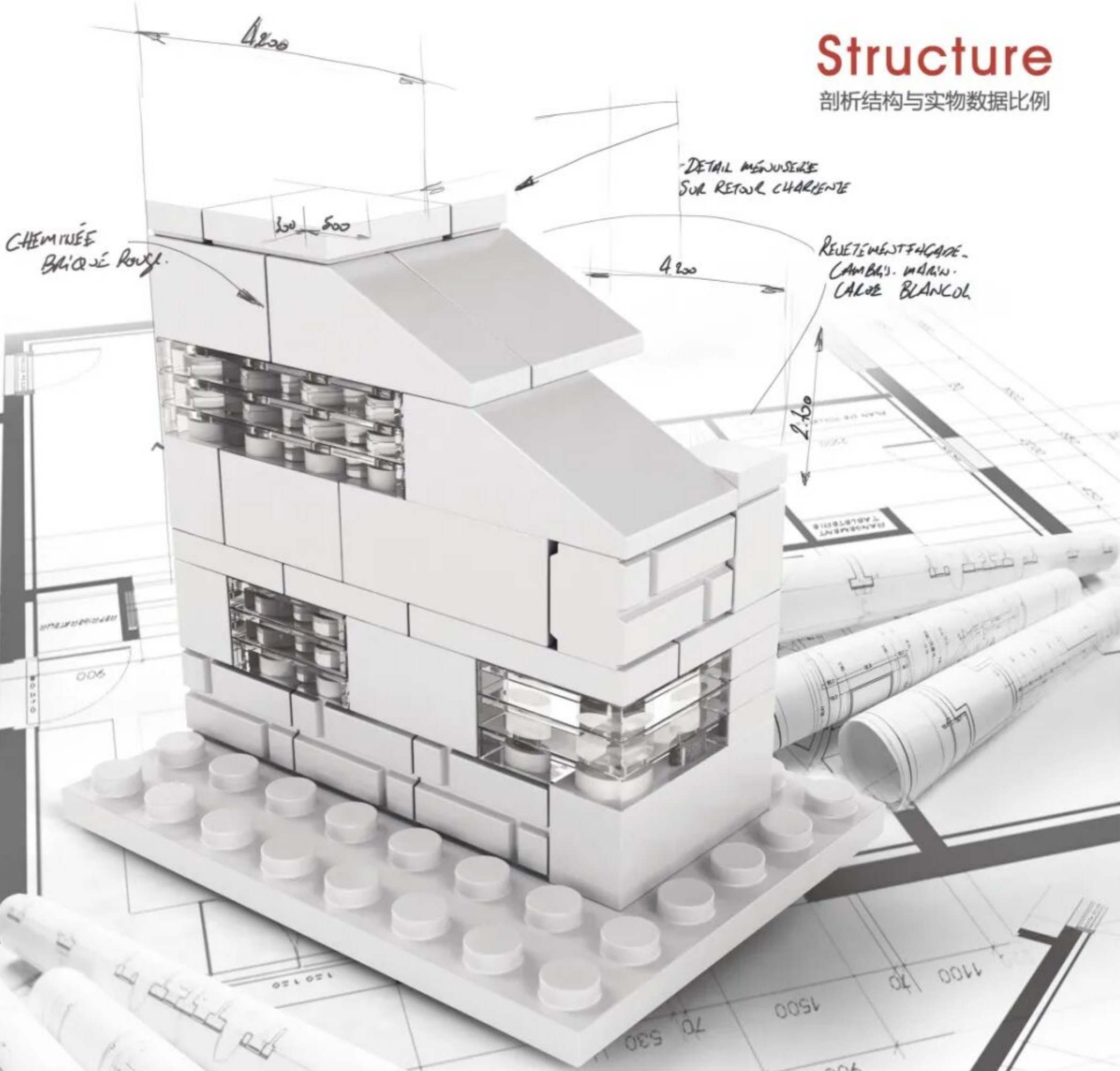

Anatomy

Analyze the ratio of product structure to physical data



Building Block

The world's great architecture
3D construction

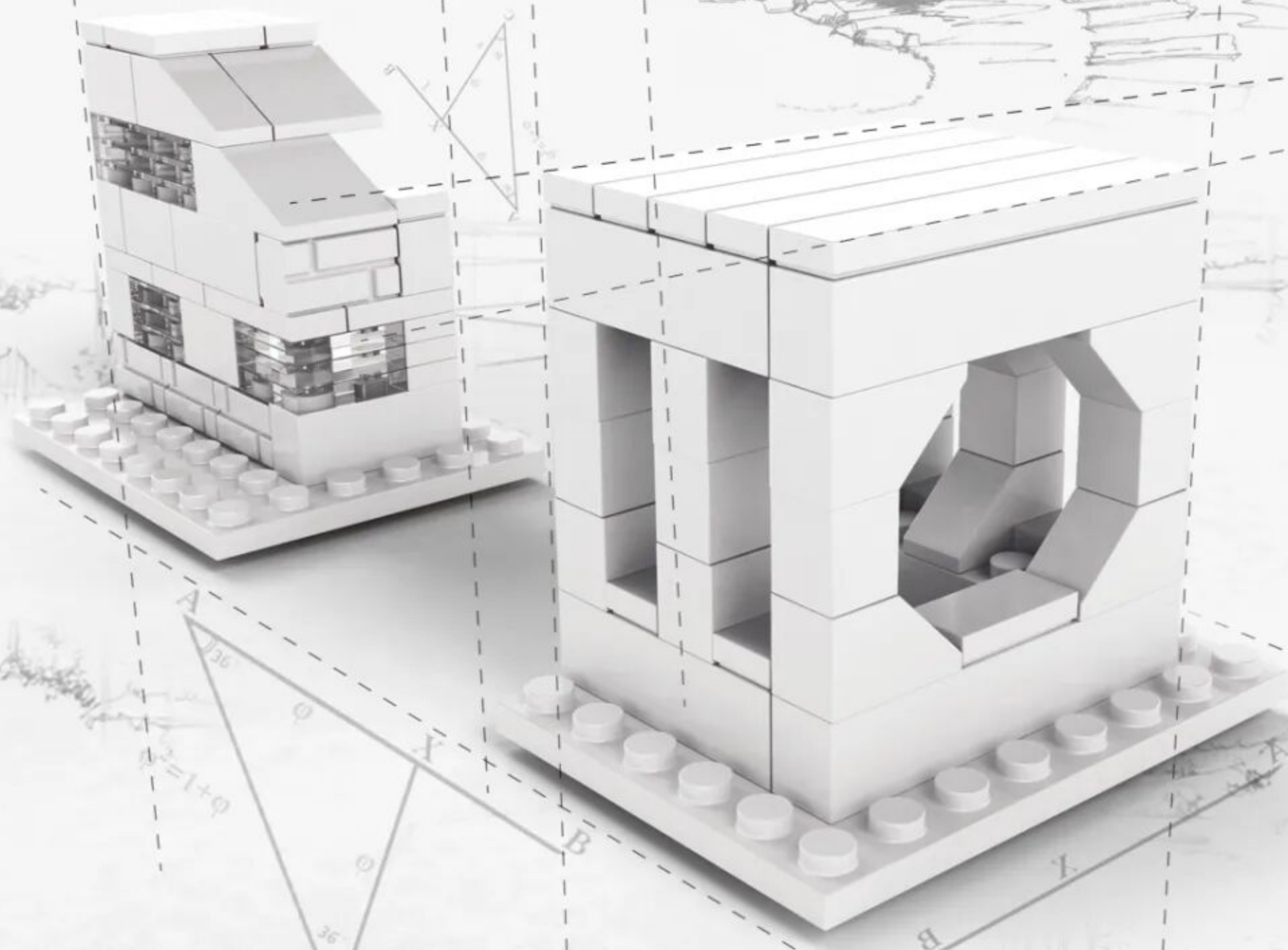

proportion

对产品精确分析运用3维技术最大限度还原实物比例

Accurate analysis of the product, using 3D technology to maximize the reduction of physical objects.

Creativity

外观设计结合黄金比例更好展现美感

DETAIL MENUSENNE
SUR RETOUR CHARENTE

REVETEMENT FACADE
CAMBIS. MARIN.
CALOE BLANCOL

CHEMINÉE
Brique rouge.

$$\varphi = \frac{a+b}{a} = \frac{a}{b} = 1,61803398875$$



Architecture

Use the golden ratio in the design and development of the product to better show the beauty of the product.

Brickseparator

积木起件器使用说明

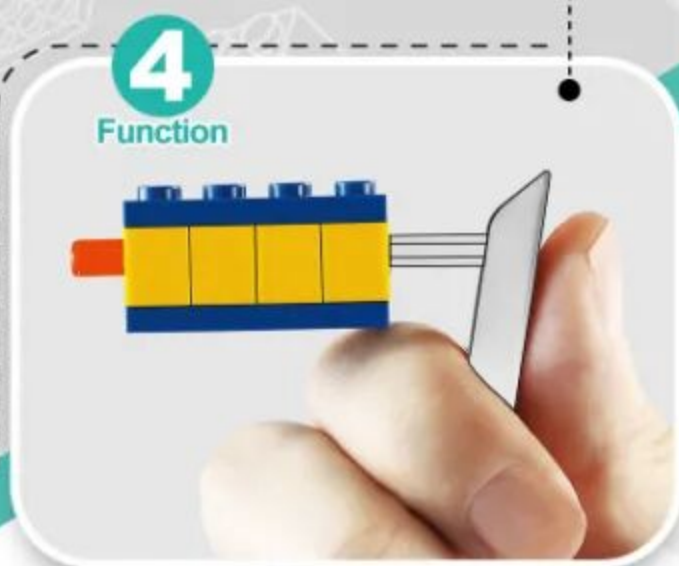
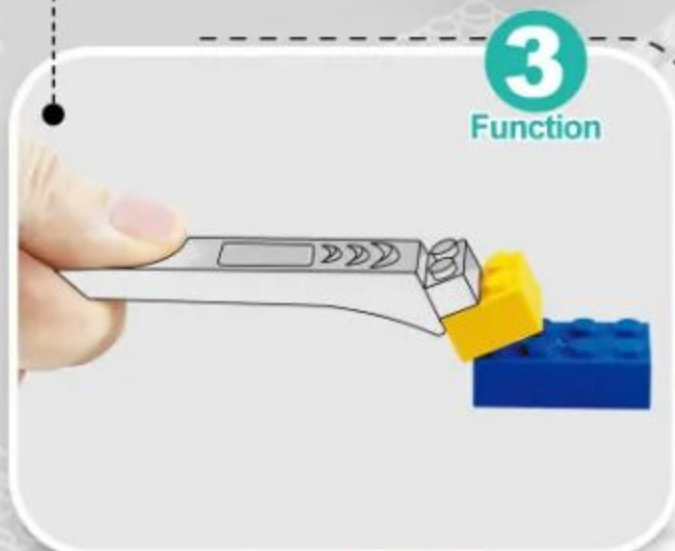
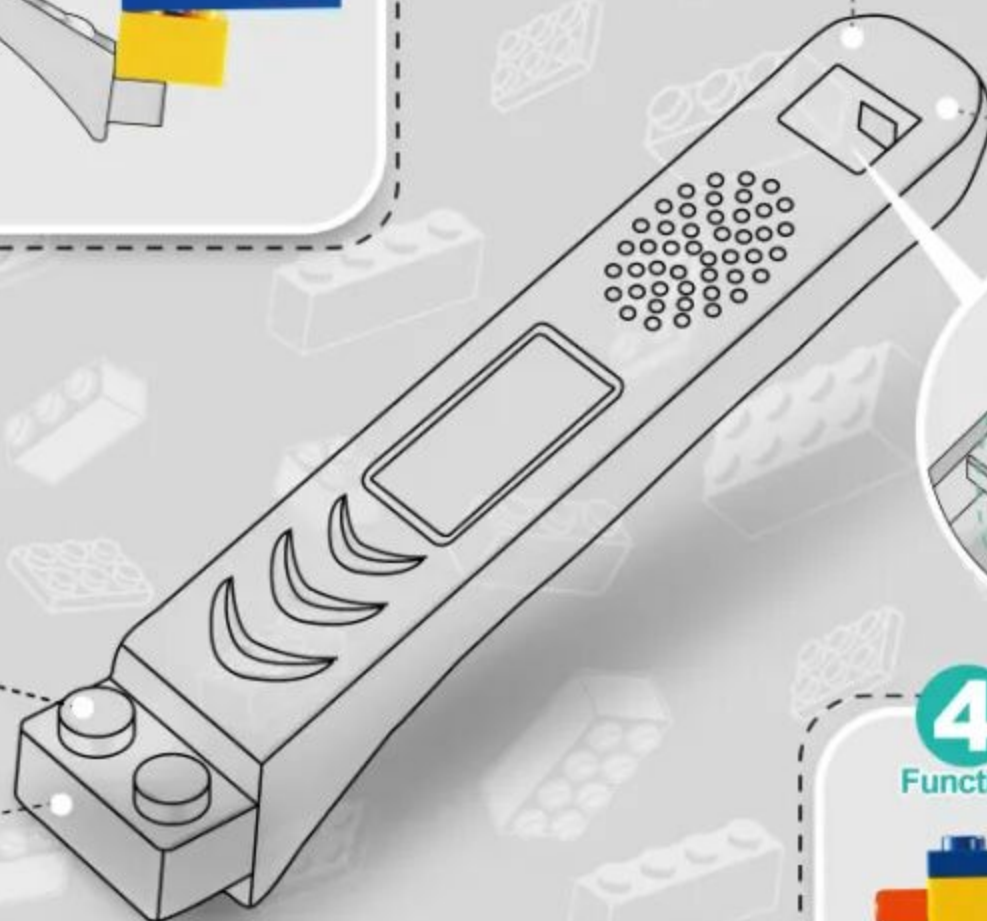
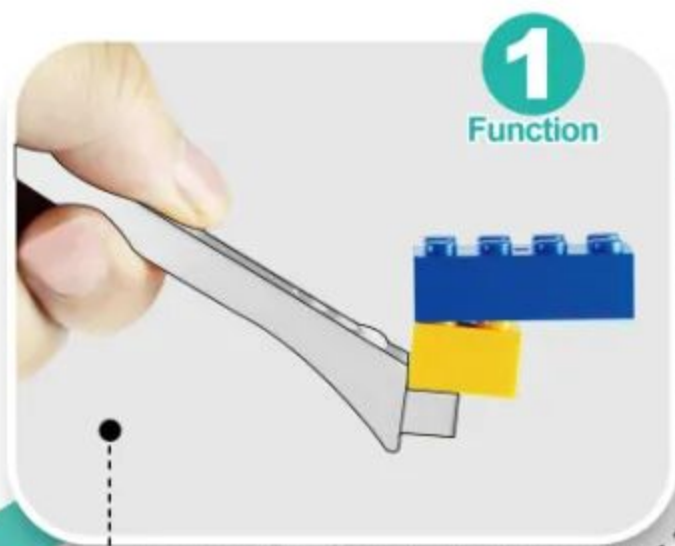

4 ways to make installation easier
让安装更简单

Building Blocks

拼装小技巧



- First open the product packaging according to the instructions.

按指导用正确方式拆解产品外包装。



- Summarize all parts to count the number of familiar accessories.

拆开积木包装对照说明书清单确认积木数量。



- Arranging all accessories by color helps to quickly install the product.

把确认好的积木以颜色进行分类排好以便安装。











- Carefully install the product and learn about building.

按说明书步骤拼装并完成你的积木模型。

INSTALLATION
TIPS

1:1 Physical Reference Table

十字棒配件1:1尺寸参照表

2	$(1 \times 2) = 2$	
3	$(1 \times 3) = 3$	
4	$(1 \times 4) = 4$	
5	$(1 \times 5) = 5$	
6	$(1 \times 6) = 6$	
7	$(1 \times 7) = 7$	
8	$(1 \times 8) = 8$	
9	$(1 \times 9) = 9$	
10	$(1 \times 10) = 10$	
12	$(1 \times 12) = 12$	
16	$(1 \times 14) = 14$	



1:1

Instructions For Use

让安装更简单



The Colosseum
OF Rome
Italy

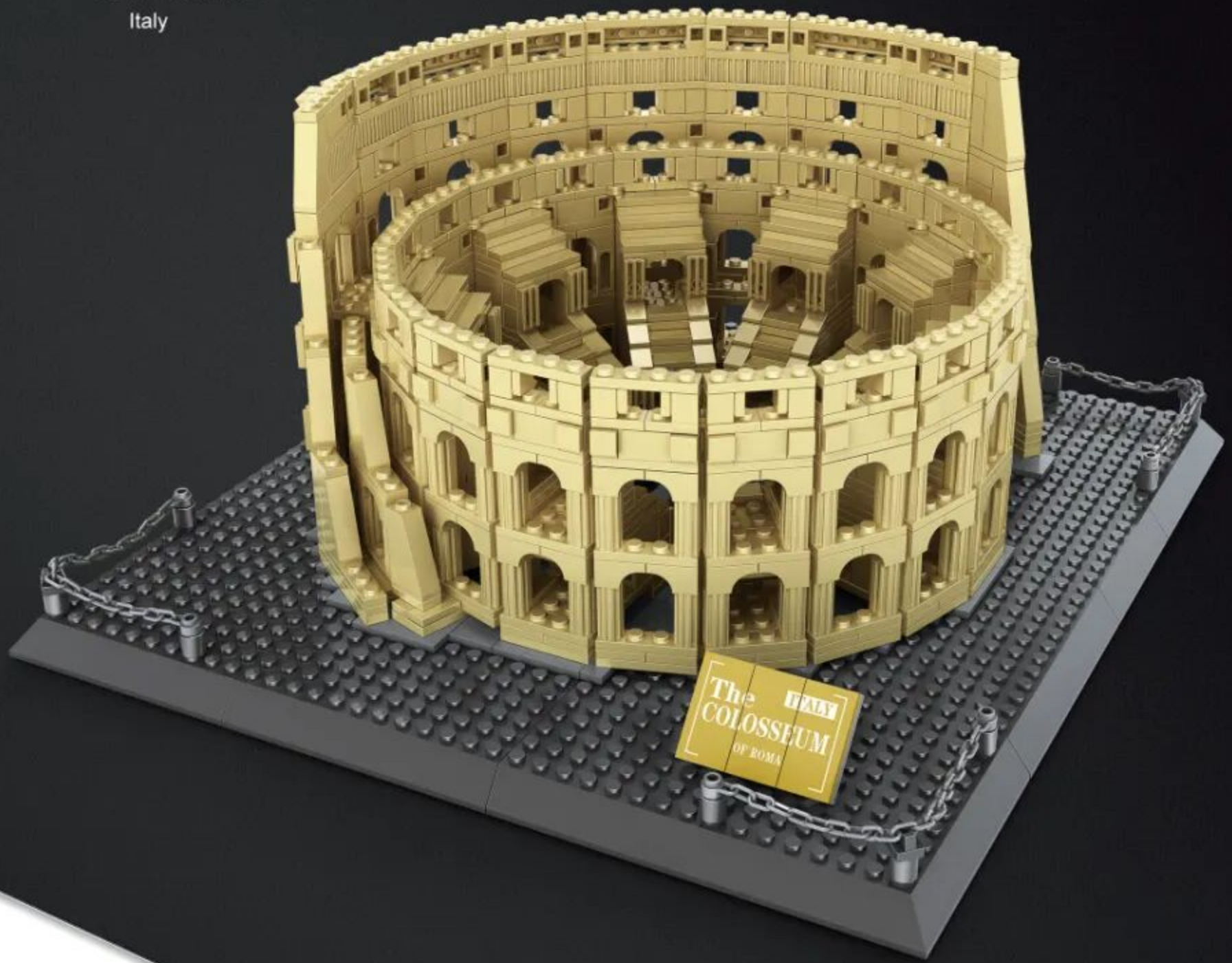

Front

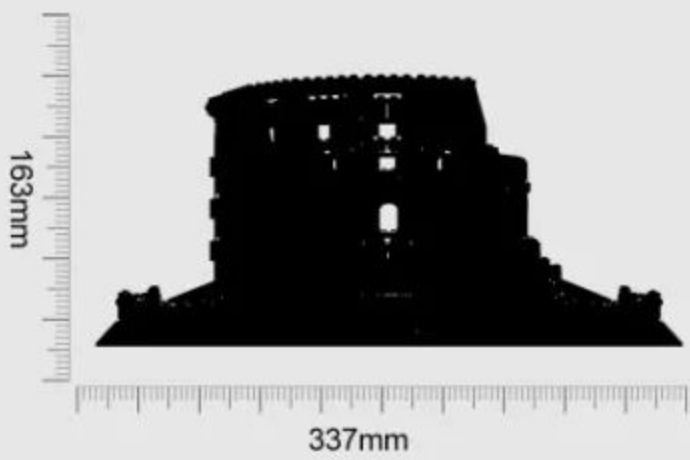

Left

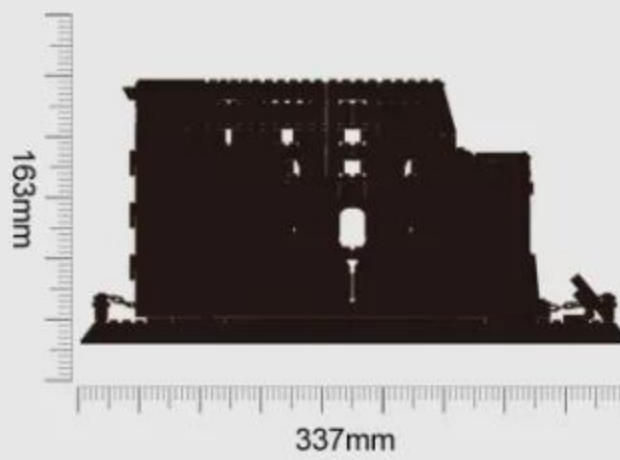

Back

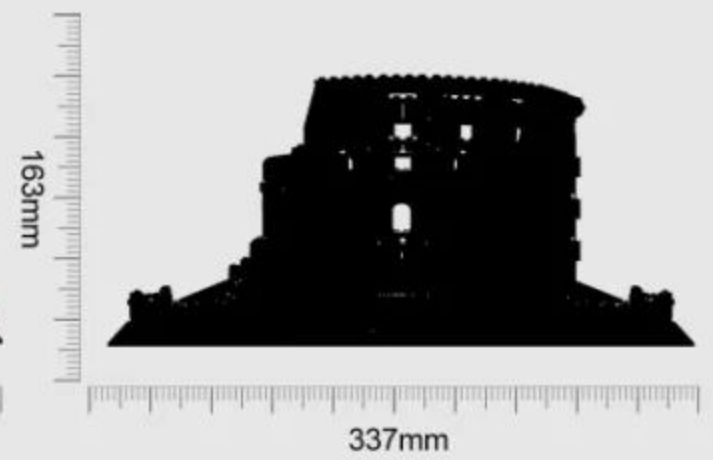

Product Size:337X337X163mm



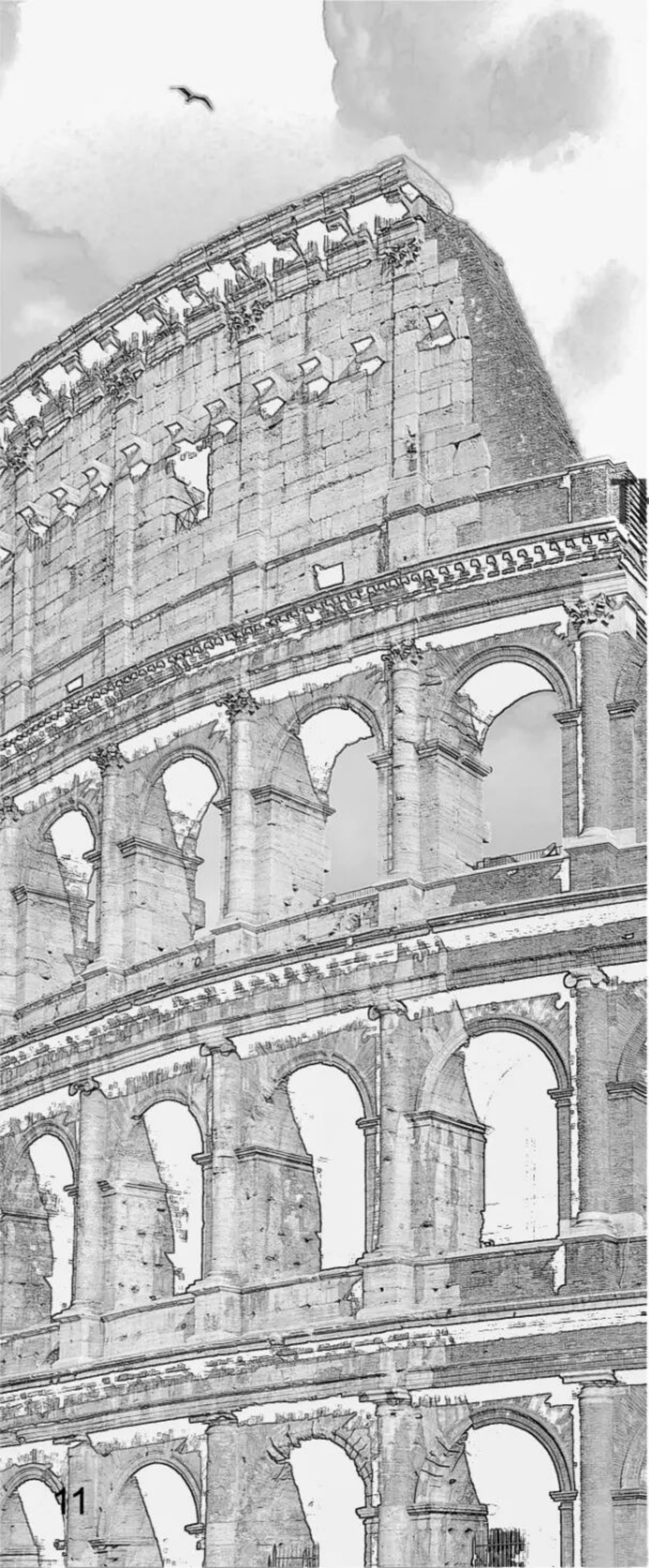

意大利罗马斗兽场

THE Colosseum ■

OF Rome

Italy

The contents of this chapter refer to the Wikipedia website.

本章内容参考维基百科网站，更多资讯可自行查阅。

The world's great architecture

About The Building



The Colosseum or Coliseum also known as the Flavian Amphitheatre or Colosseo is an oval amphitheatre in the centre of the city of Rome, Italy. Built of travertine, tuff, and brick-faced concrete, it is the largest amphitheatre ever built. The Colosseum is situated just east of the Roman Forum. Construction began under the emperor Vespasian in AD 72 and was completed in AD 80 under his successor and heir, Titus. Further modifications were made during the reign of Domitian (81–96). These three emperors are known as the Flavian dynasty, and the amphitheatre was named in Latin for its association with their family name .

The Colosseum could hold, it is estimated, between 50,000 and 80,000 spectators, having an average audience of some 65,000; it was used for gladiatorial contests and public spectacles such as mock sea battles (for only a short time as the hypogeum was soon filled in with mechanisms to support the other activities), animal hunts, executions, re-enactments of famous battles, and dramas based on Classical mythology. The building ceased to be used for entertainment in the early medieval era. It was later reused for such purposes as housing, workshops, quarters for a religious order, a fortress, a quarry, and a Christian shrine.



Arena and hypogeum

The hypogeum was connected by underground tunnels to a number of points outside the Colosseum. Animals and performers were brought through the tunnel from nearby stables, with the gladiators' barracks at the Ludus Magnus to the east also being connected by tunnels. Separate tunnels were provided for the Emperor and the Vestal Virgins to permit them to enter and exit the Colosseum without needing to pass through the crowds.



Supporting buildings

The Colosseum and its activities supported a substantial industry in the area. In addition to the amphitheatre itself, many other buildings nearby were linked to the games. Immediately to the east is the remains of the Ludus Magnus, a training school for gladiators. This was connected to the Colosseum by an underground passage, to allow easy access for the gladiators. The Ludus Magnus had its own miniature training arena, which was itself a popular attraction for Roman spectators. Other training schools were in the same area, including the Ludus Matutinus (Morning School), where fighters of animals were trained, plus the Dacian and Gallic Schools.



The site chosen was a flat area on the floor of a low valley between the Caelian, Esquiline and Palatine Hills, through which a canalised stream ran. By the 2nd century BC the area was densely inhabited. It was devastated by the Great Fire of Rome in AD 64, following which Nero seized much of the area to add to his personal domain. He built the grandiose Domus Aurea on the site, in front of which he created an artificial lake surrounded by pavilions, gardens and porticoes.

Original tenants and subsequent history



During the 16th and 17th century, Church officials sought a productive role for the Colosseum. Pope Sixtus V (1585–1590) planned to turn the building into a wool factory to provide employment for Rome's prostitutes, though this proposal fell through with his premature death. In 1671 Cardinal Altieri authorized its use for bullfights; a public outcry caused the idea to be hastily abandoned. In 1749, Pope Benedict XIV endorsed the view that the Colosseum was a sacred site where early Christians had been martyred.

Main Color Matching

配色方案



Pantone 7401C



Pantone cool gray2C



Color matching Adopting 2 main colors, beige, brown and gray as the main color, the more reasonable and bold color matching on the original building, making the product more atmospheric and the whole design is more reasonable.

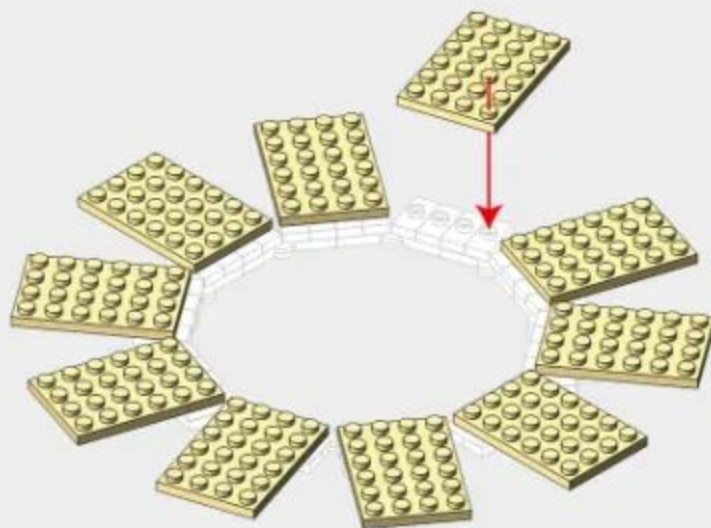
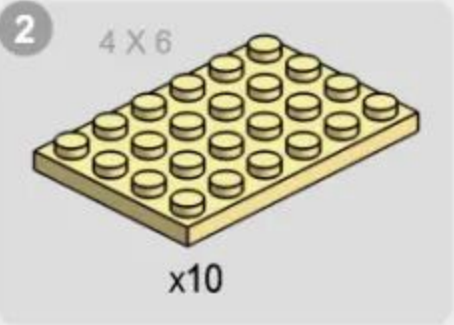
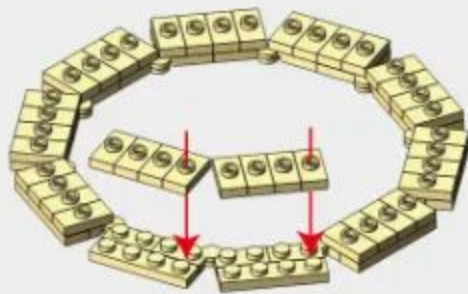
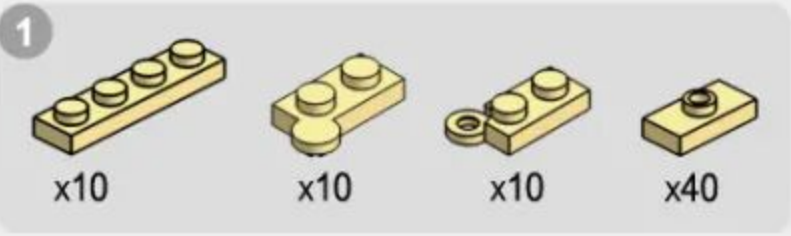

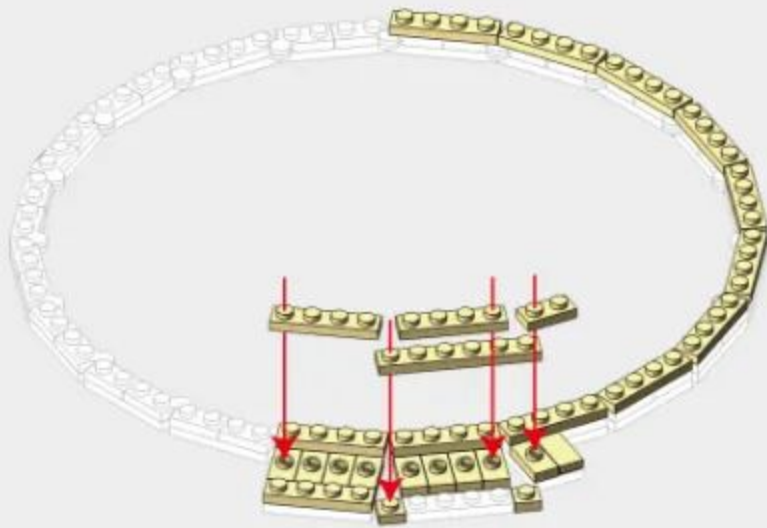
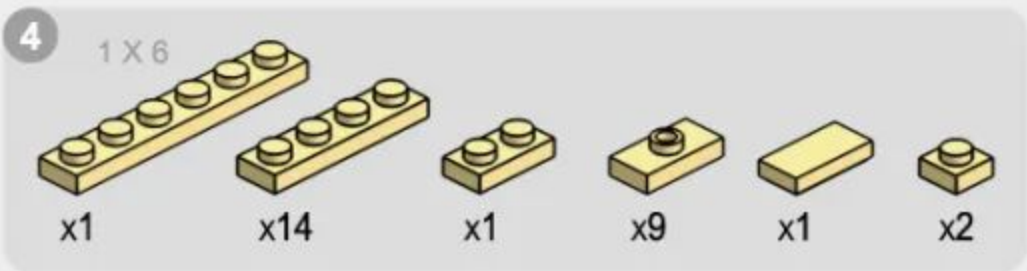
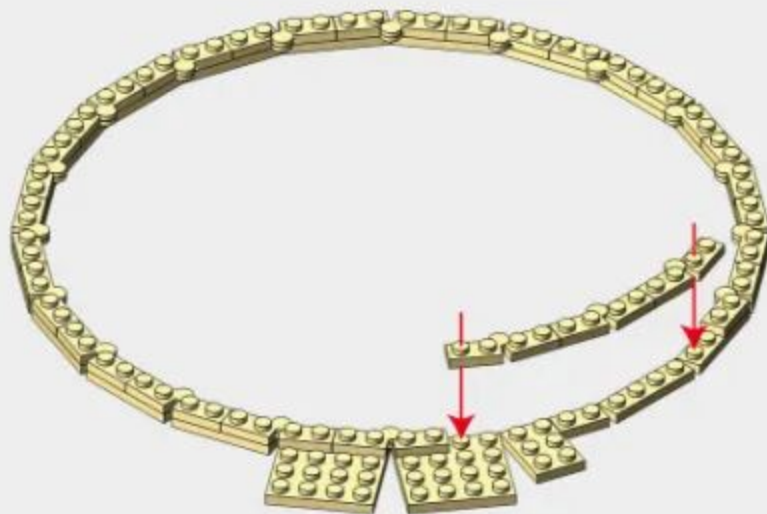
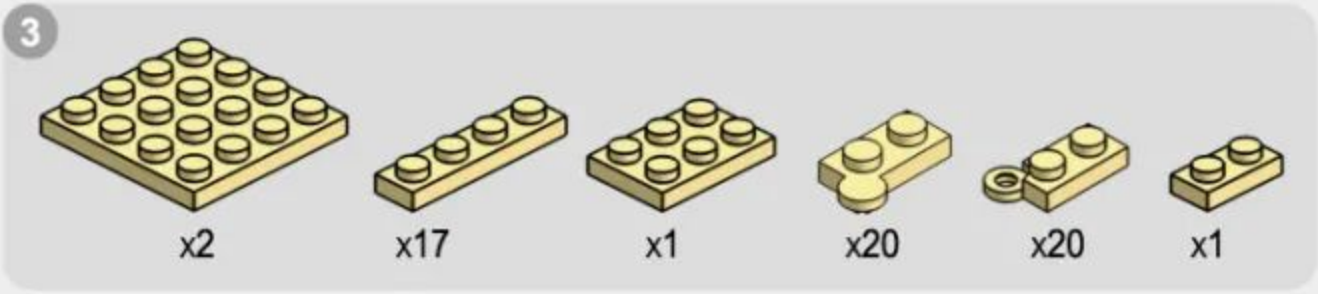

5

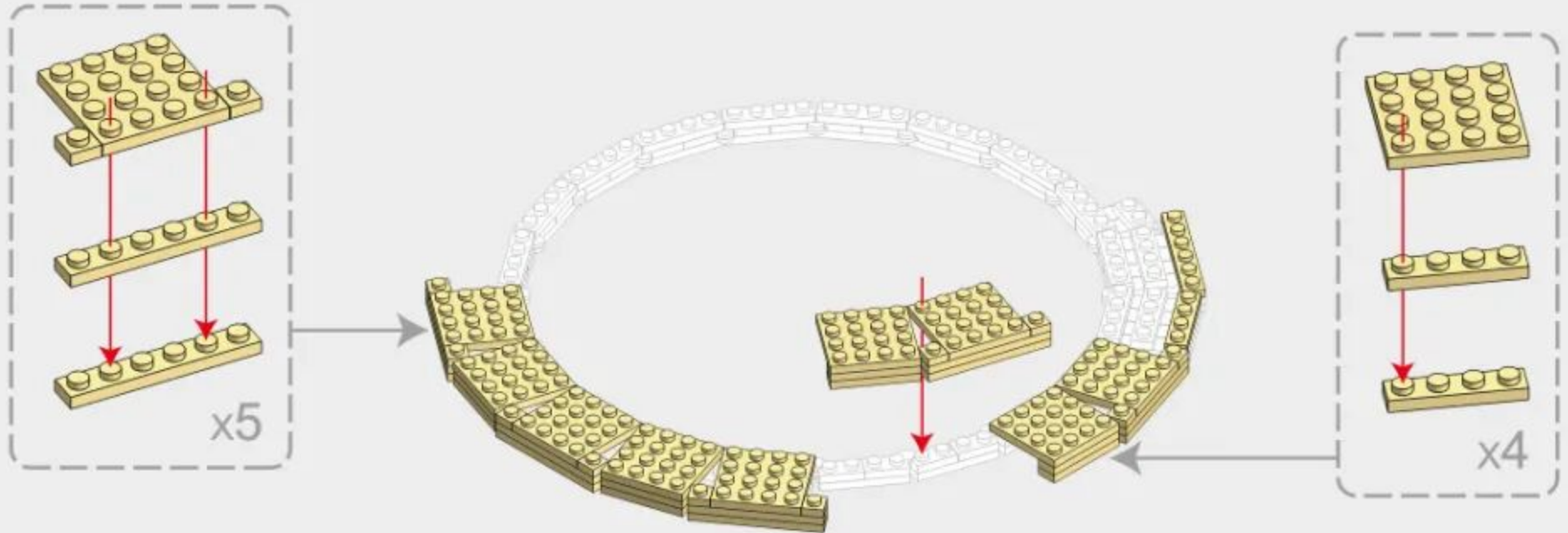
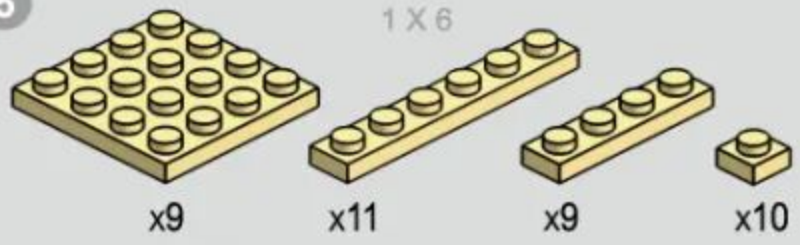

6

2 + 5

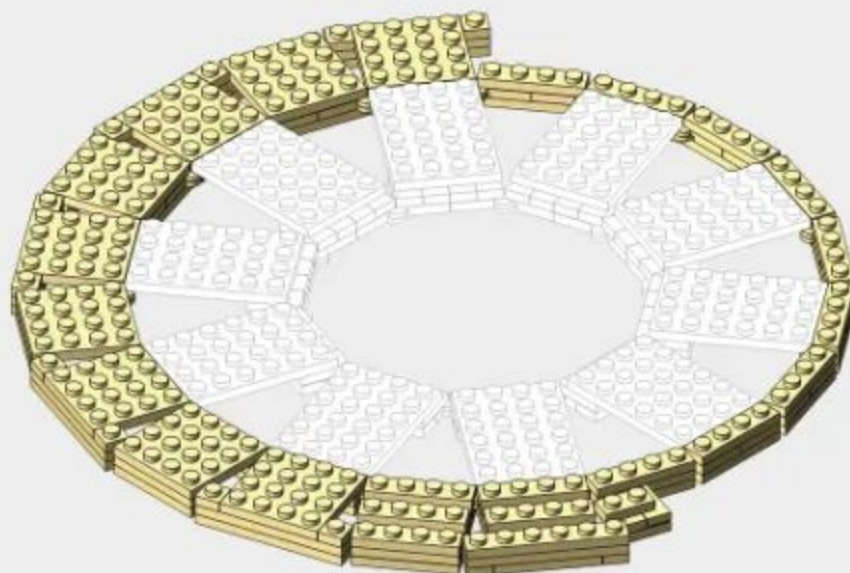

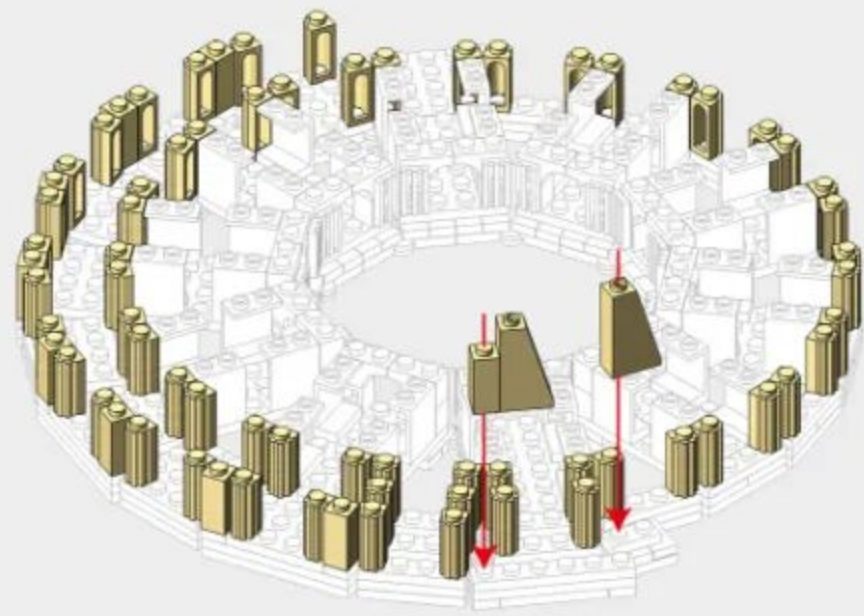
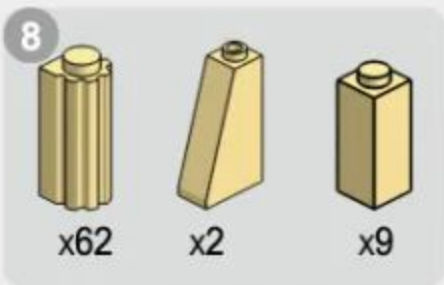
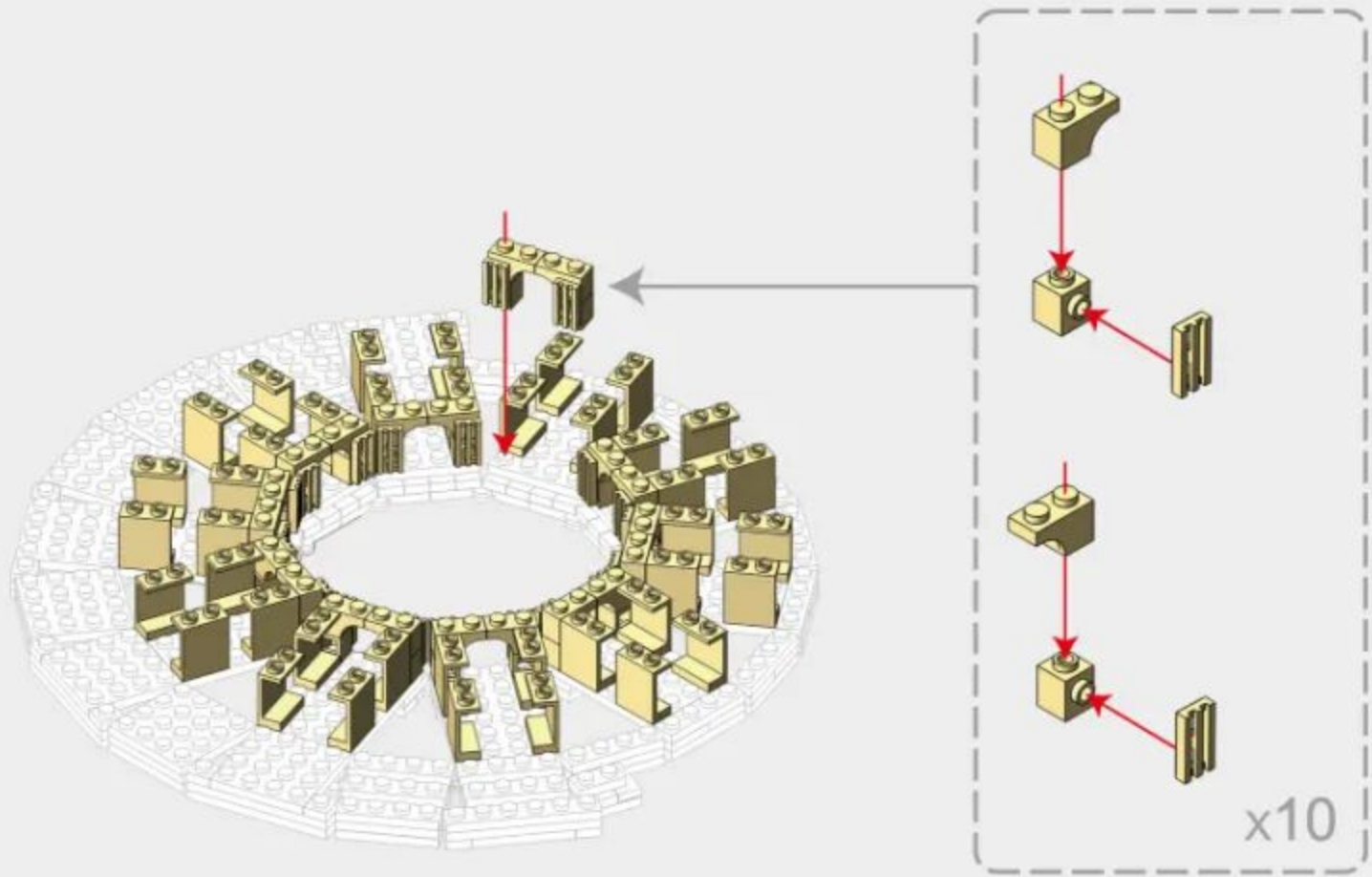

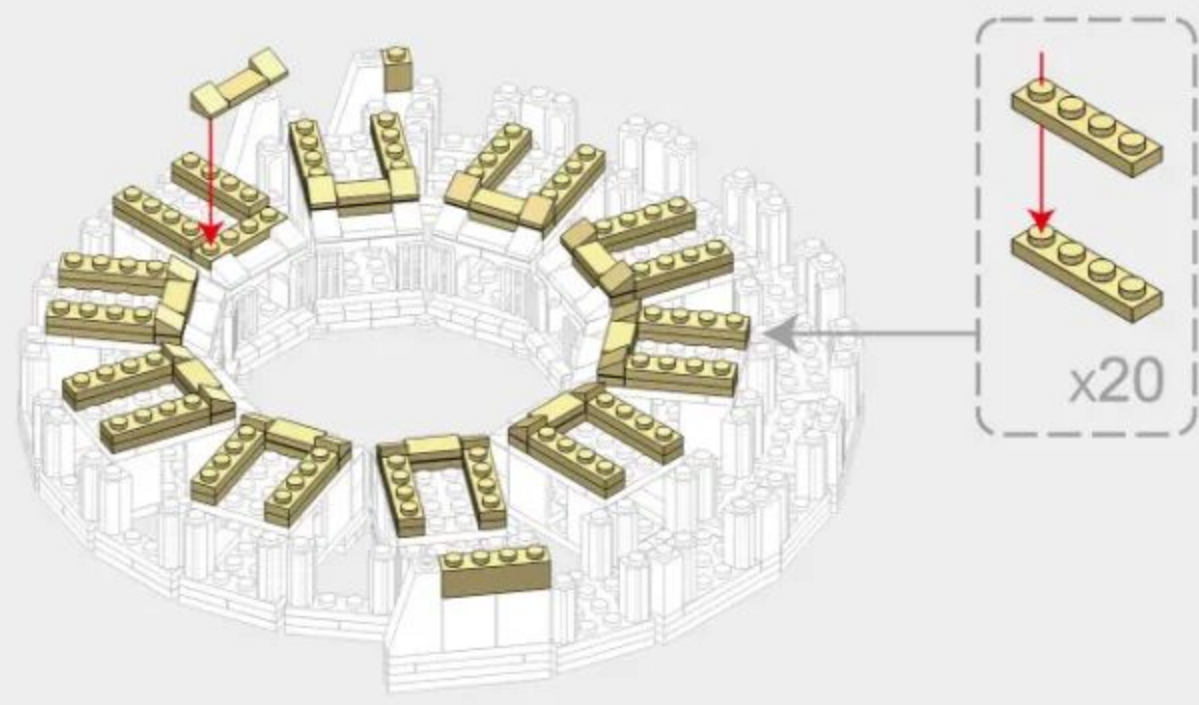
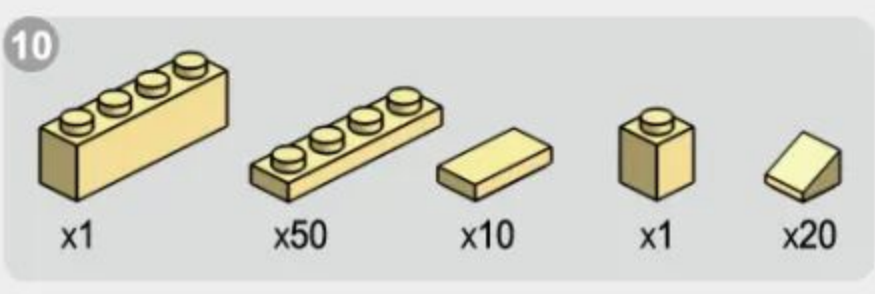
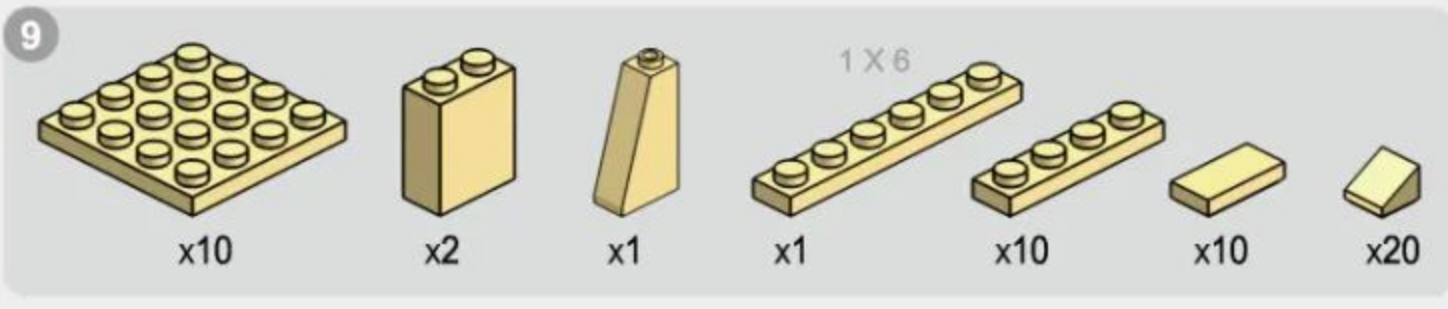

13



x2



x41



x1



x10



x20

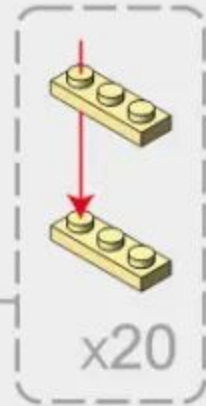

14



x1



x1



x59



x9

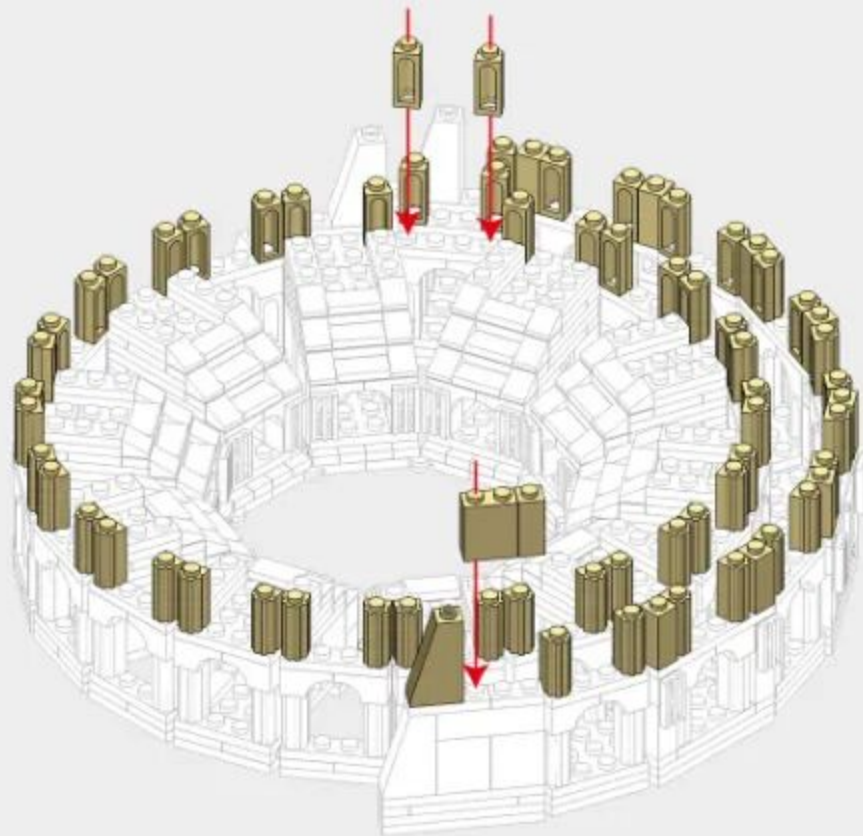

15



x20



x20



x20



x20

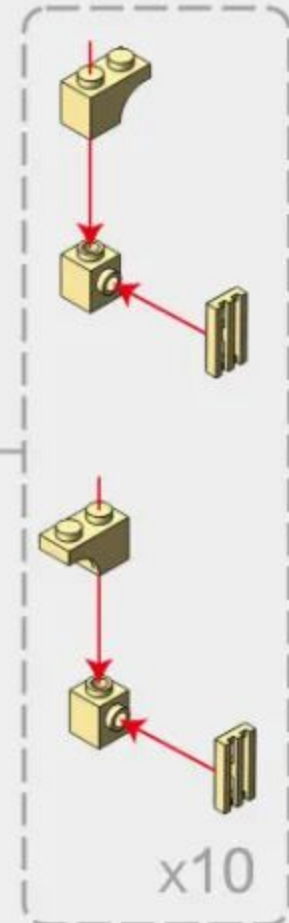
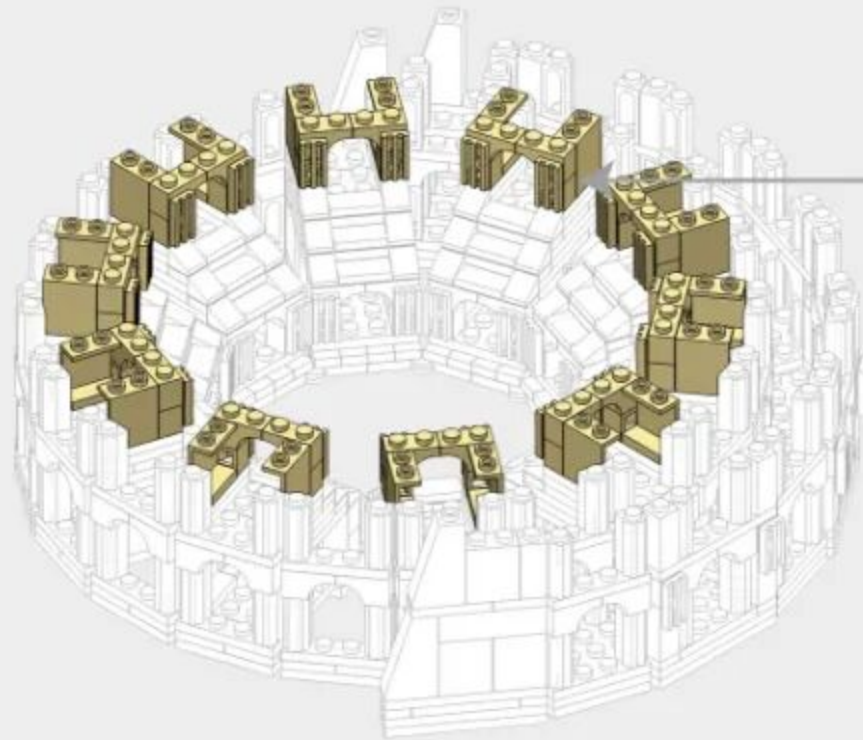

16

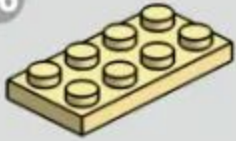

x10

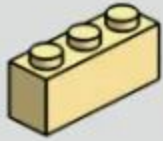

x1



x10



x40

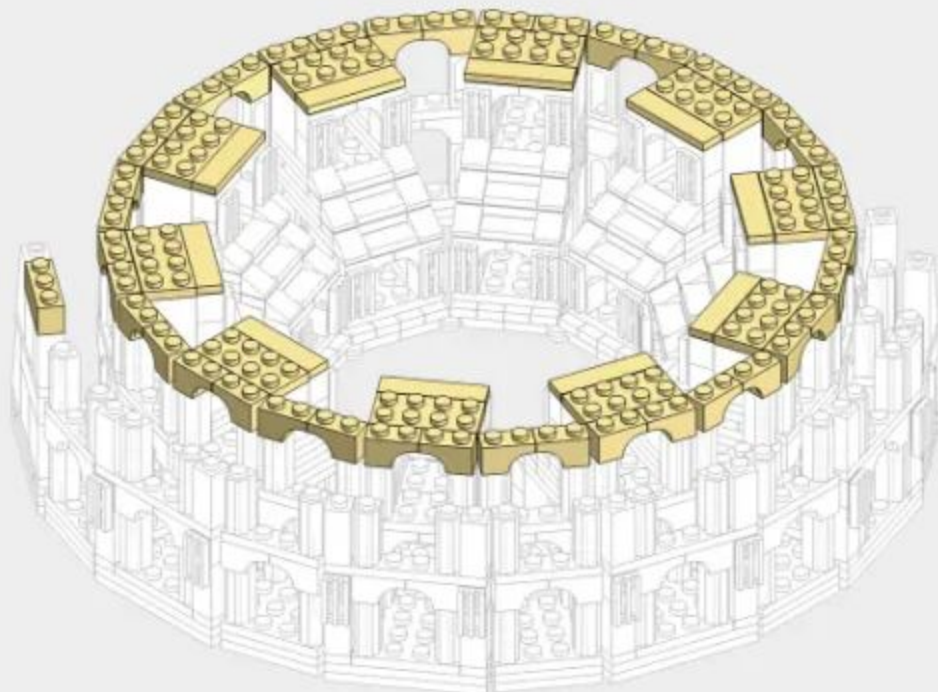

17



x19



x8



x8

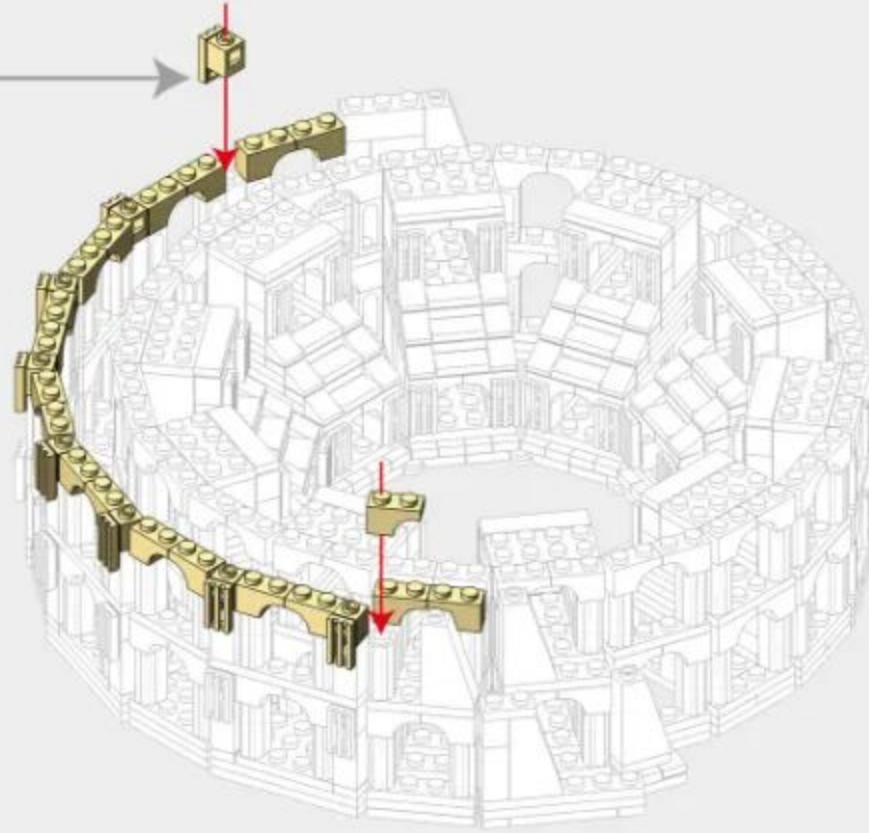
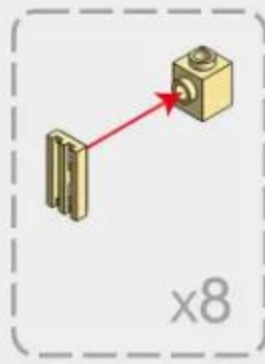

18

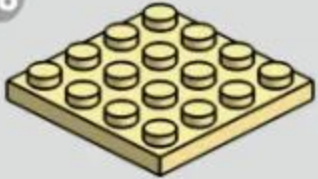

x8

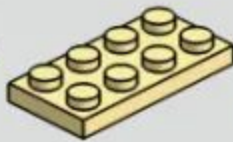

x10



x14



x1



x8

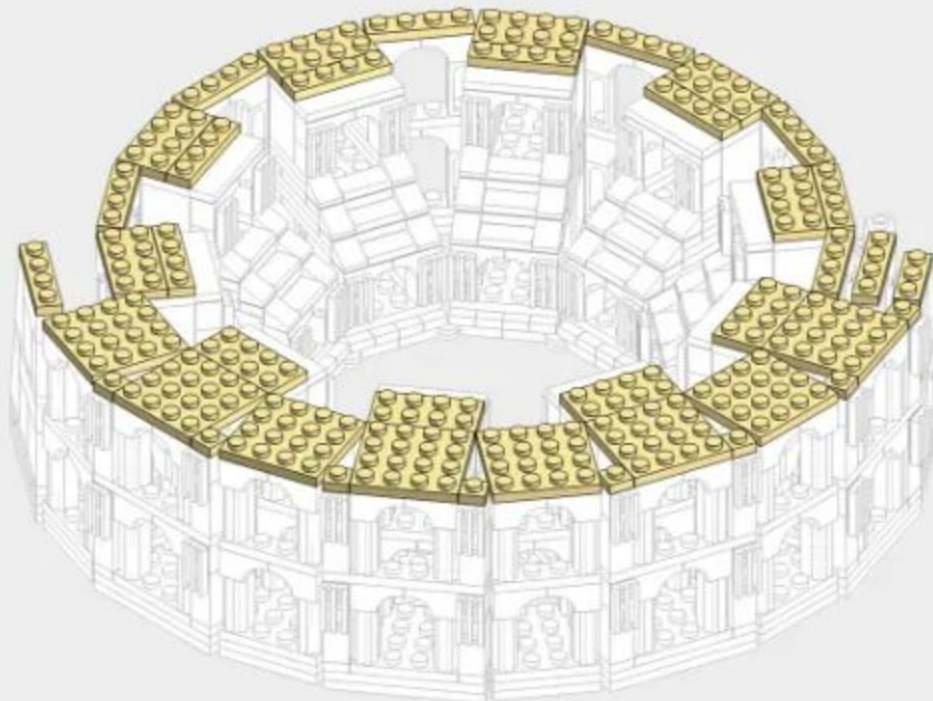

19



x20

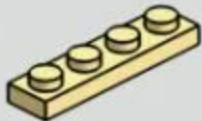

x20

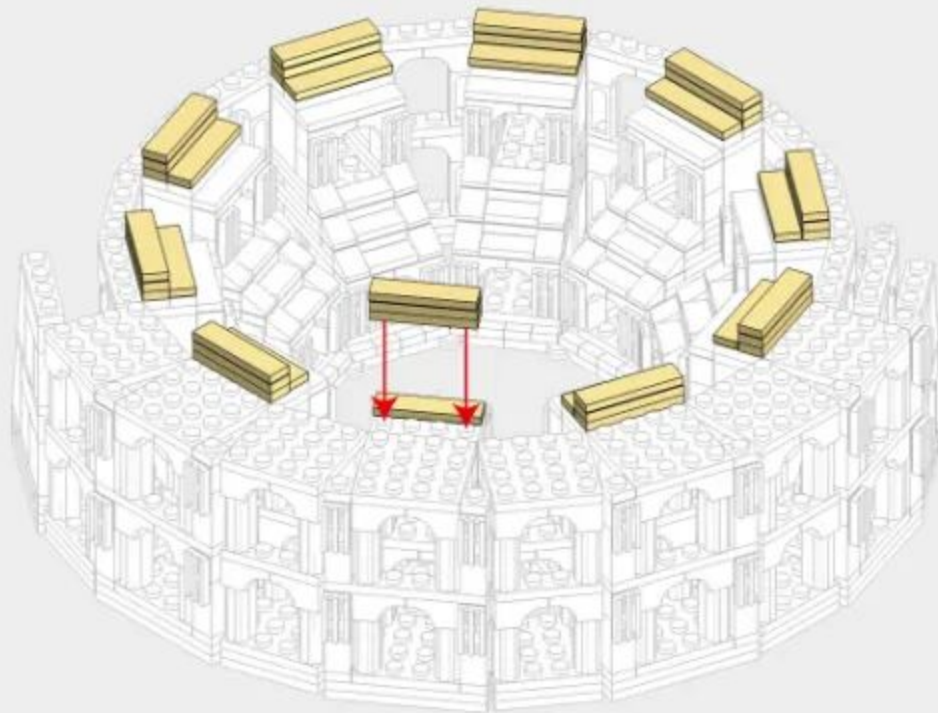

20



x20



x40



x40

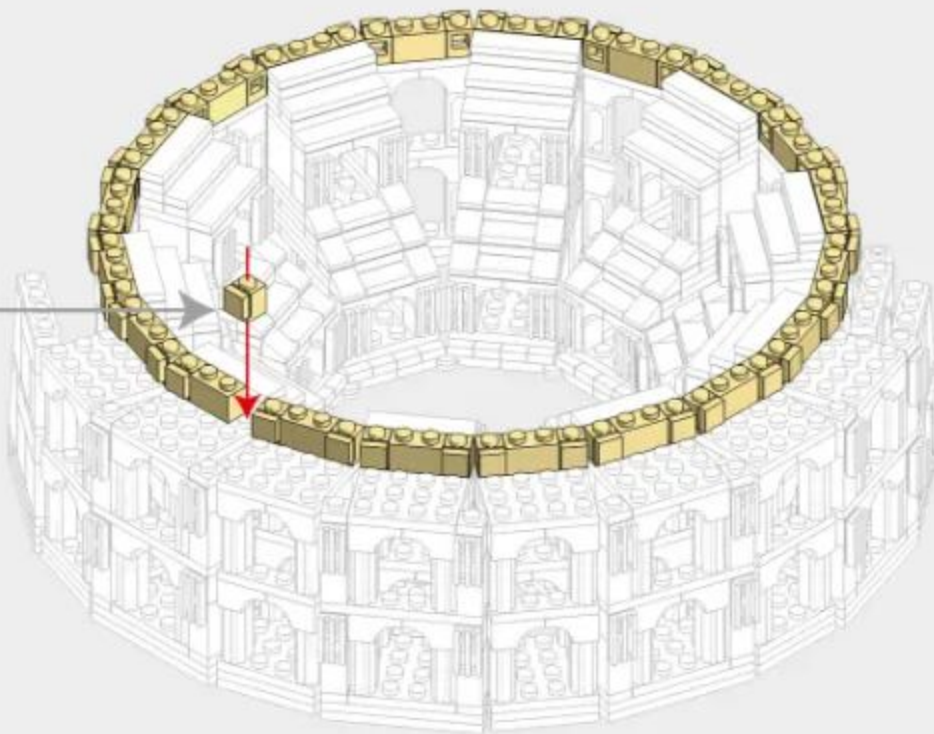

21



x1



x2



x16



x8

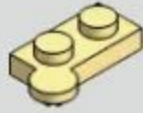

x20



x20

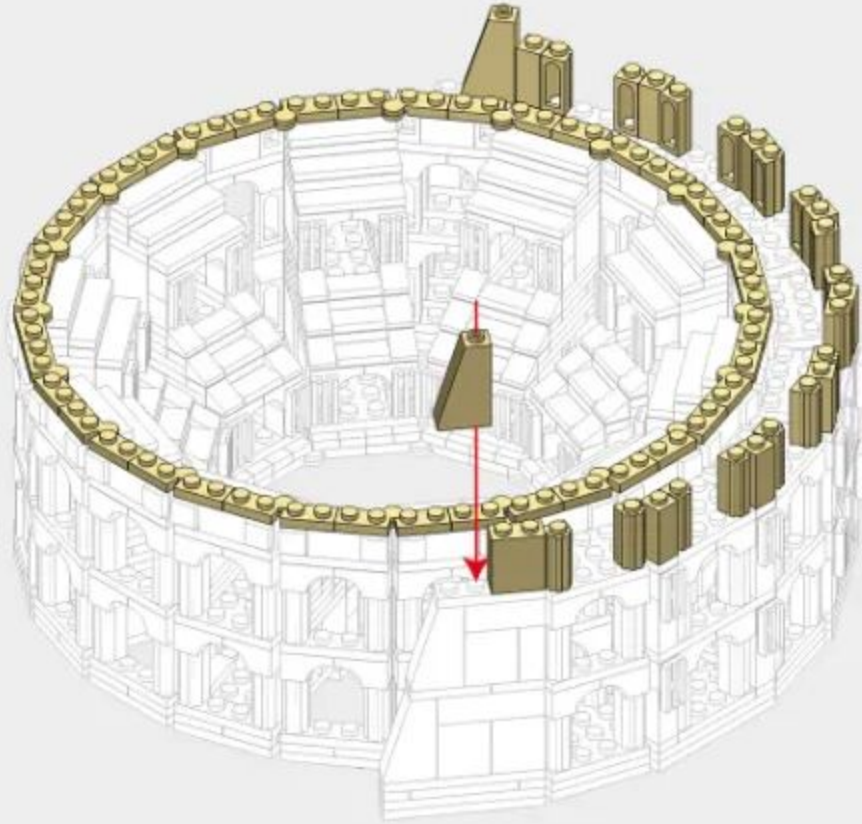

22

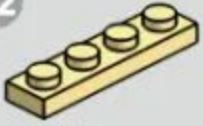

x20



x40



x40

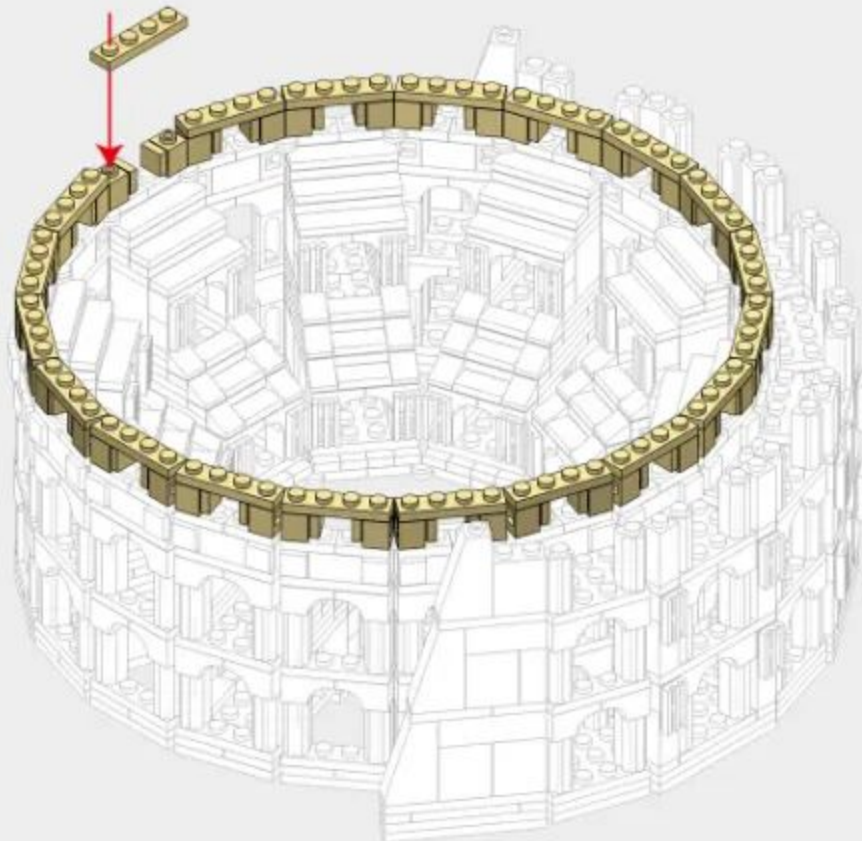

23



x16



x1



x8



x8

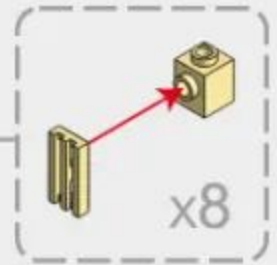
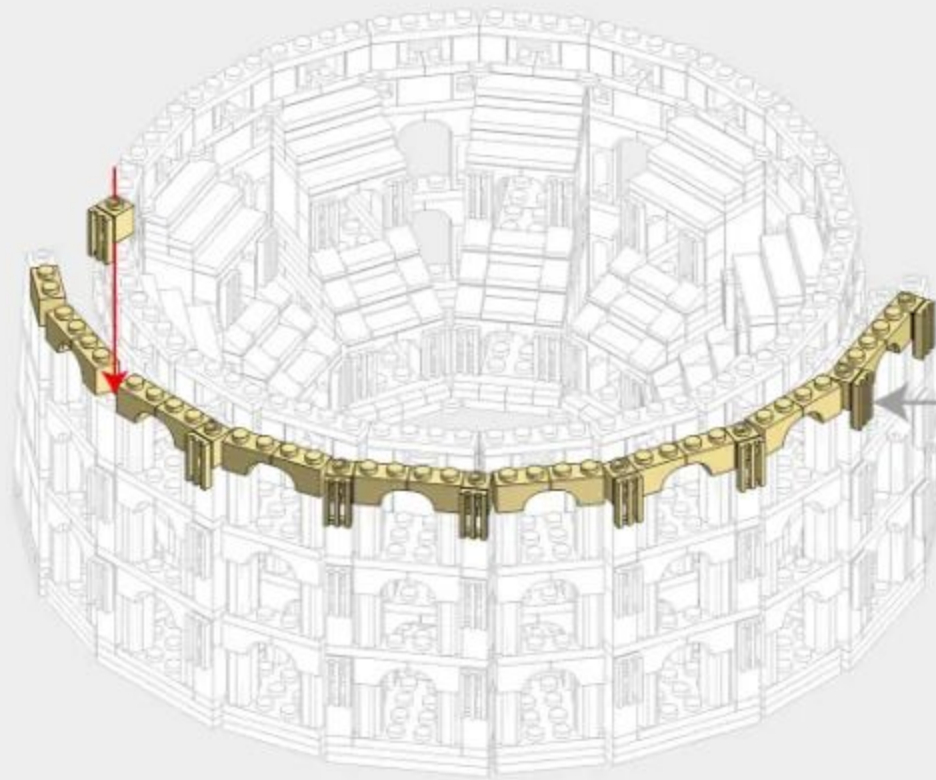

24

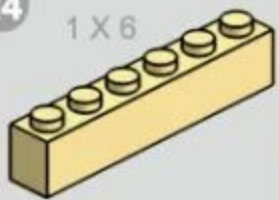

x1

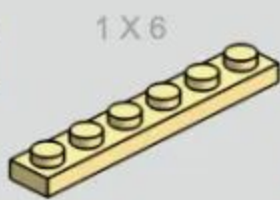

x3



x4



x1



25

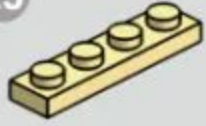

x1



x14



x6



x14

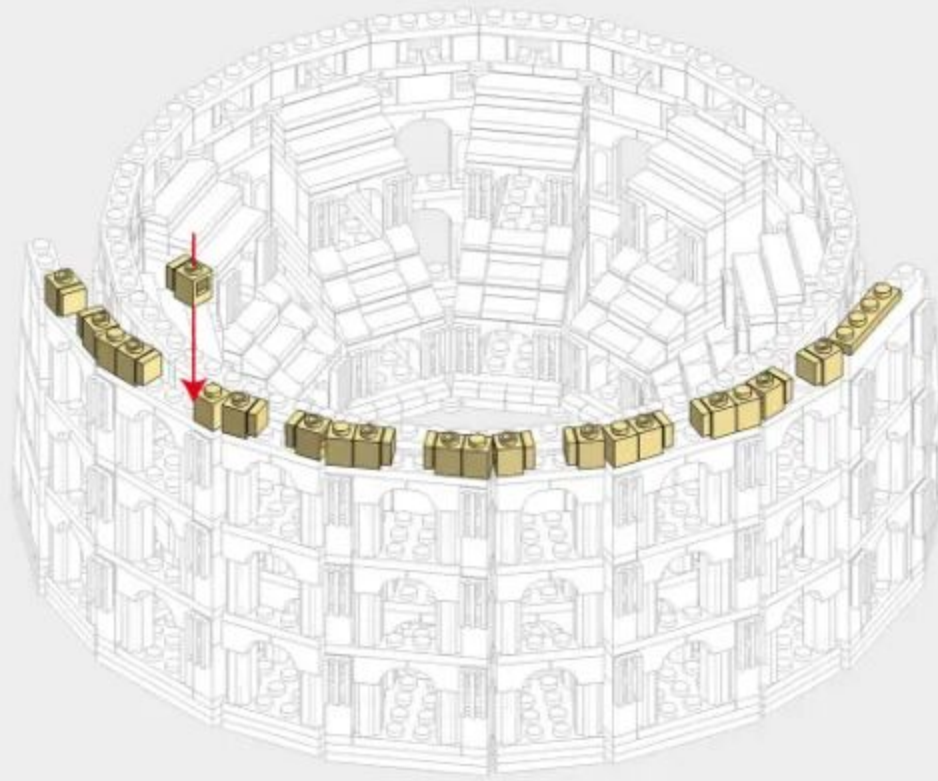

26



x1

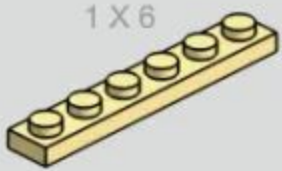

x3

1 x 6



x1



x5



x19

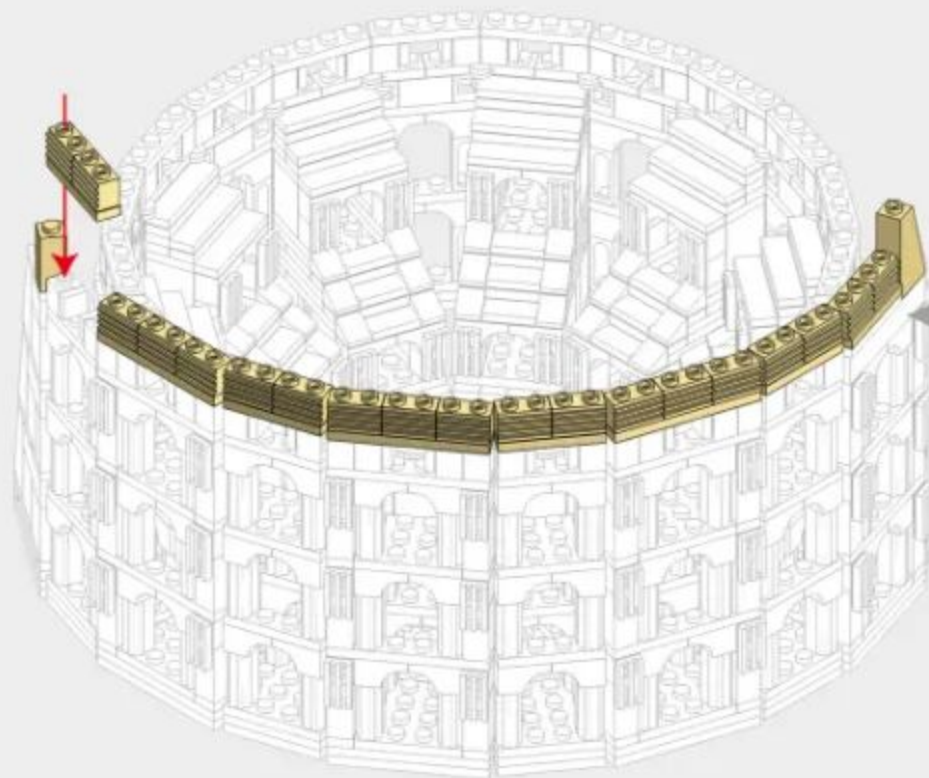

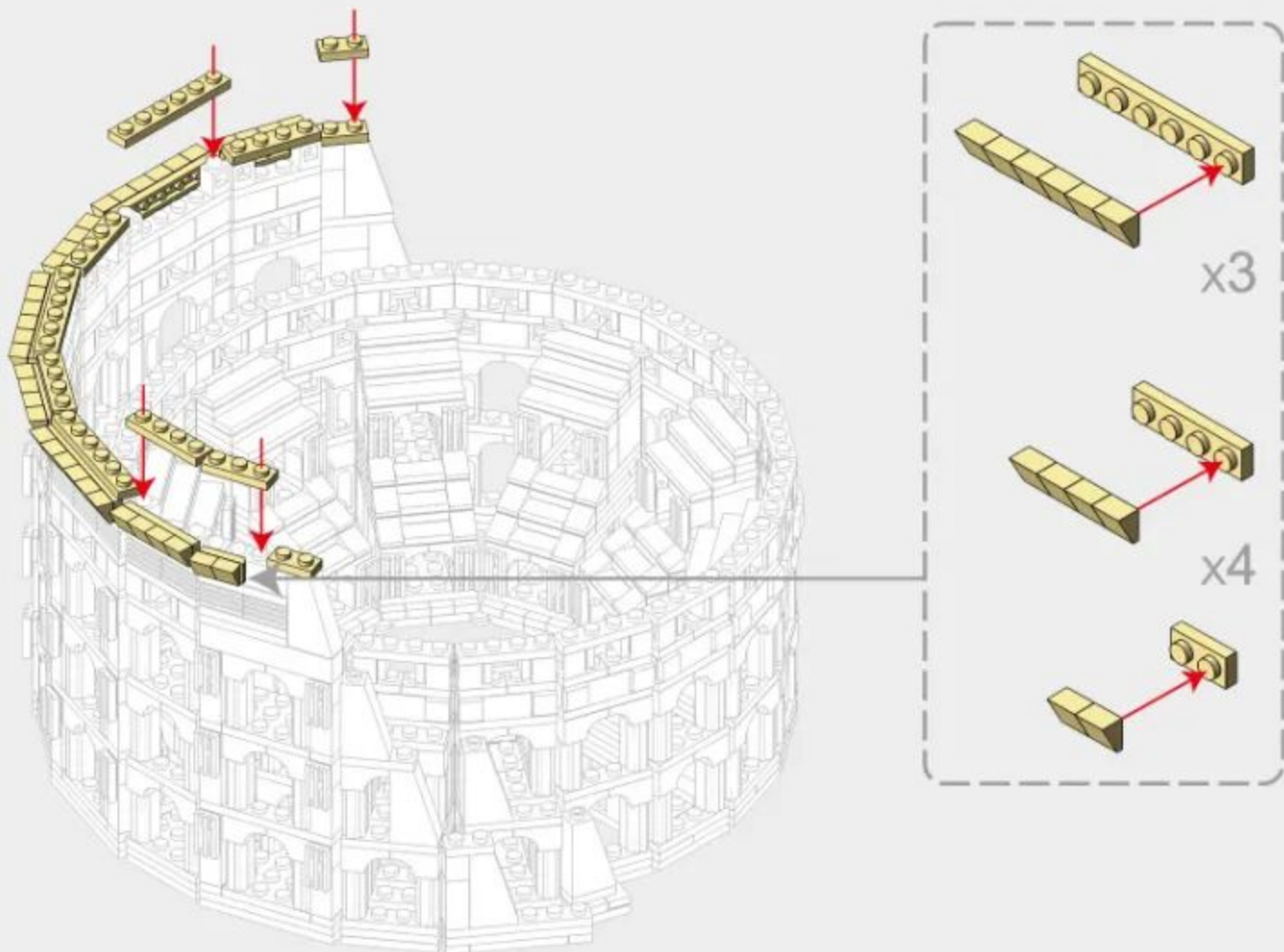
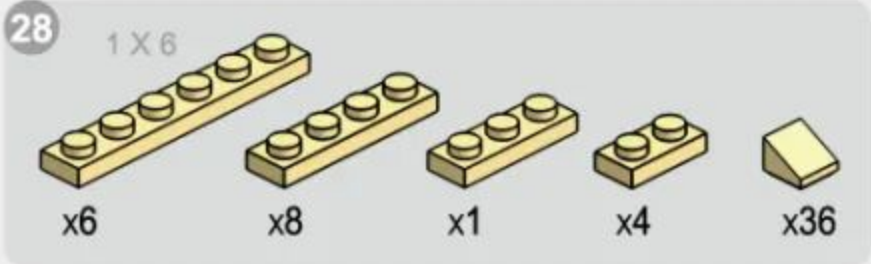
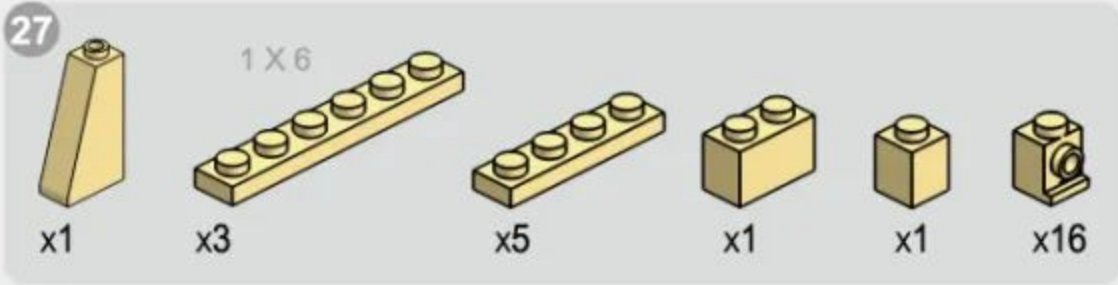

29

10 X 12

10 X 10

8 X 10

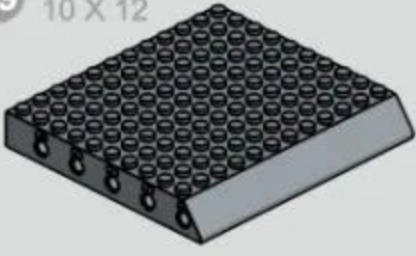

x1

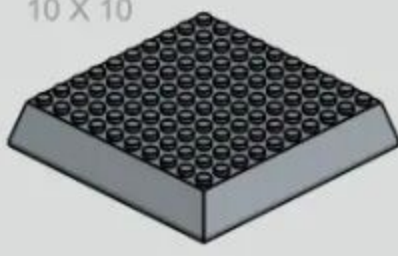

x2

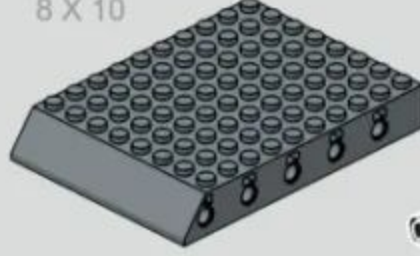

x1



x19

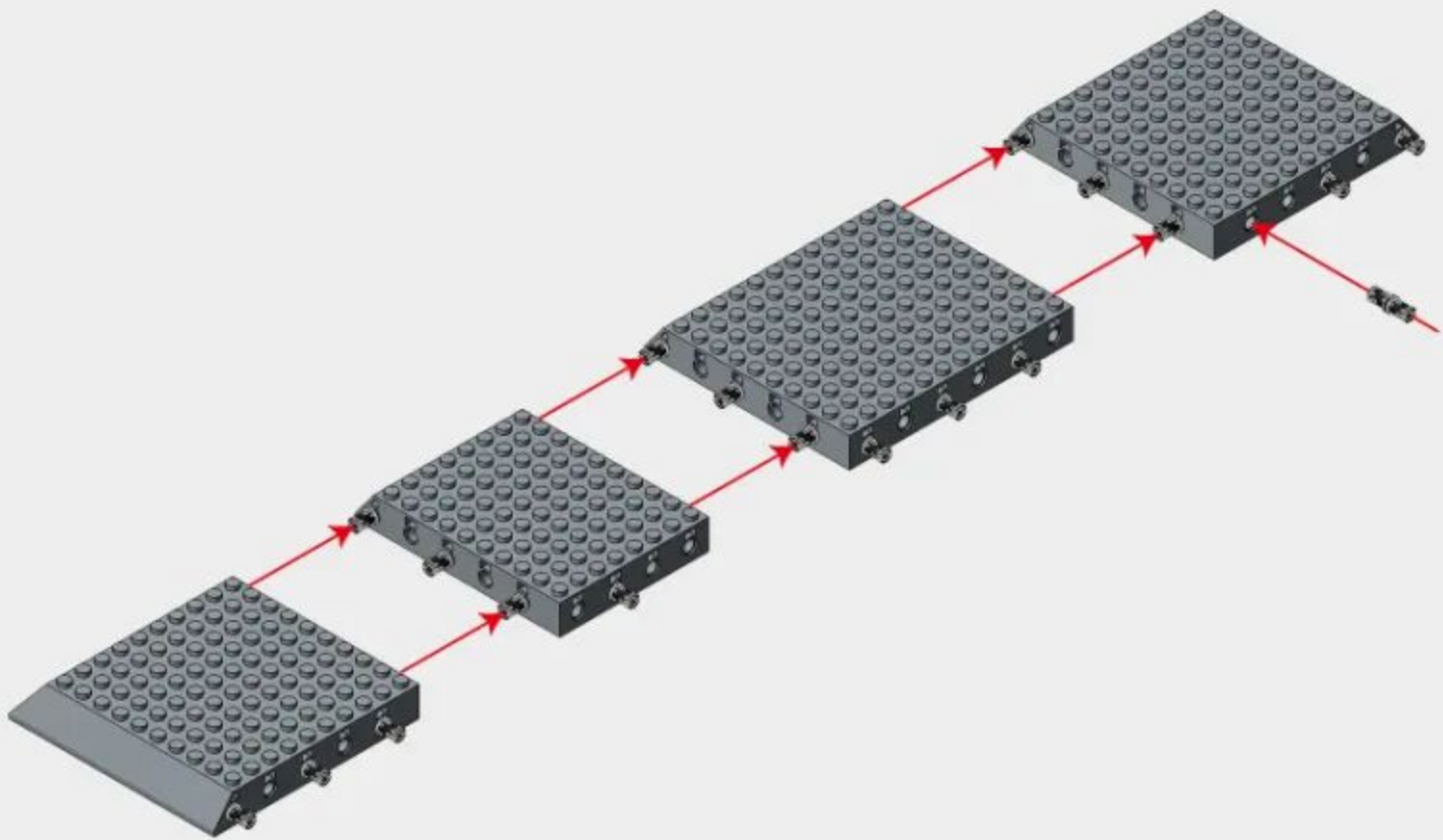

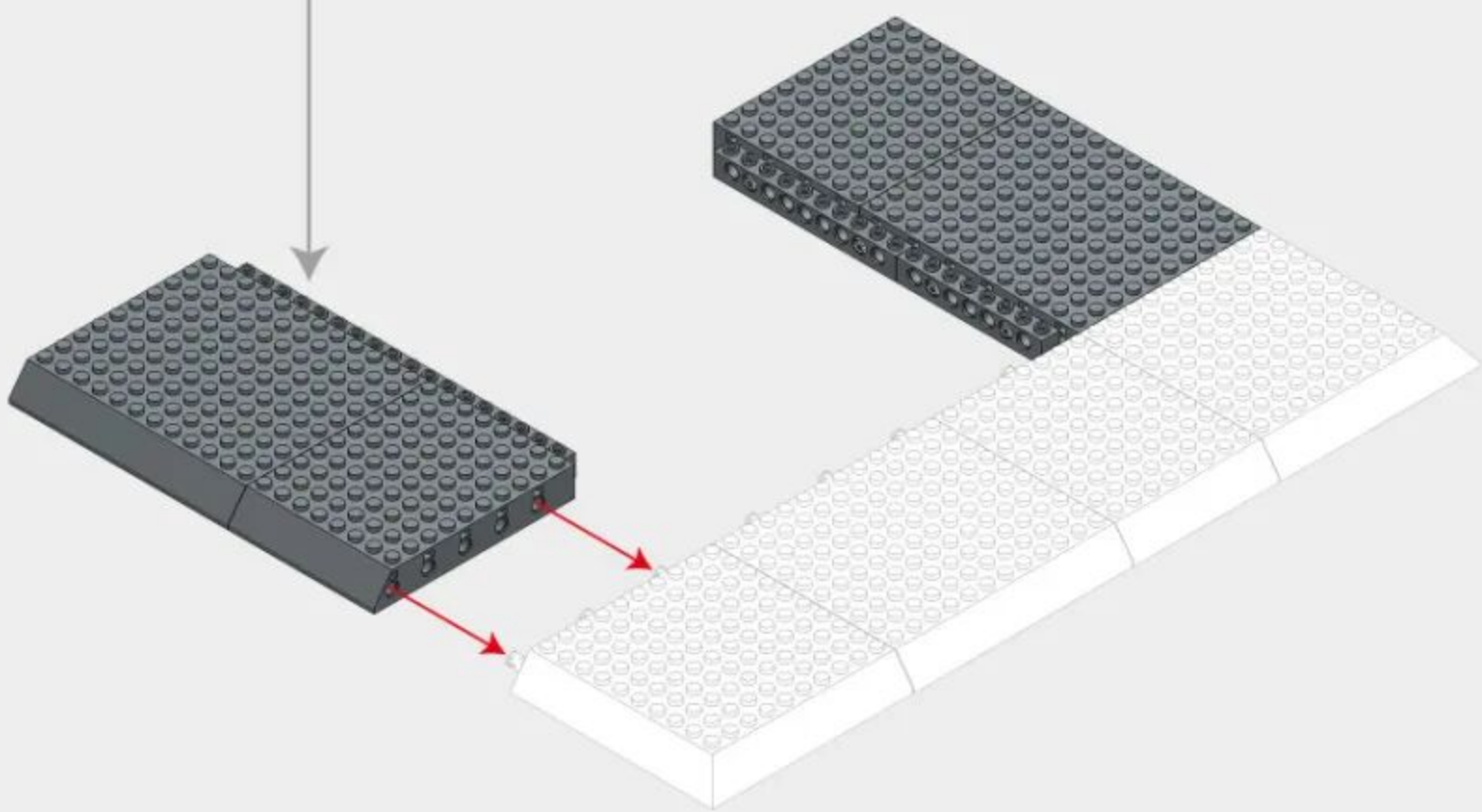
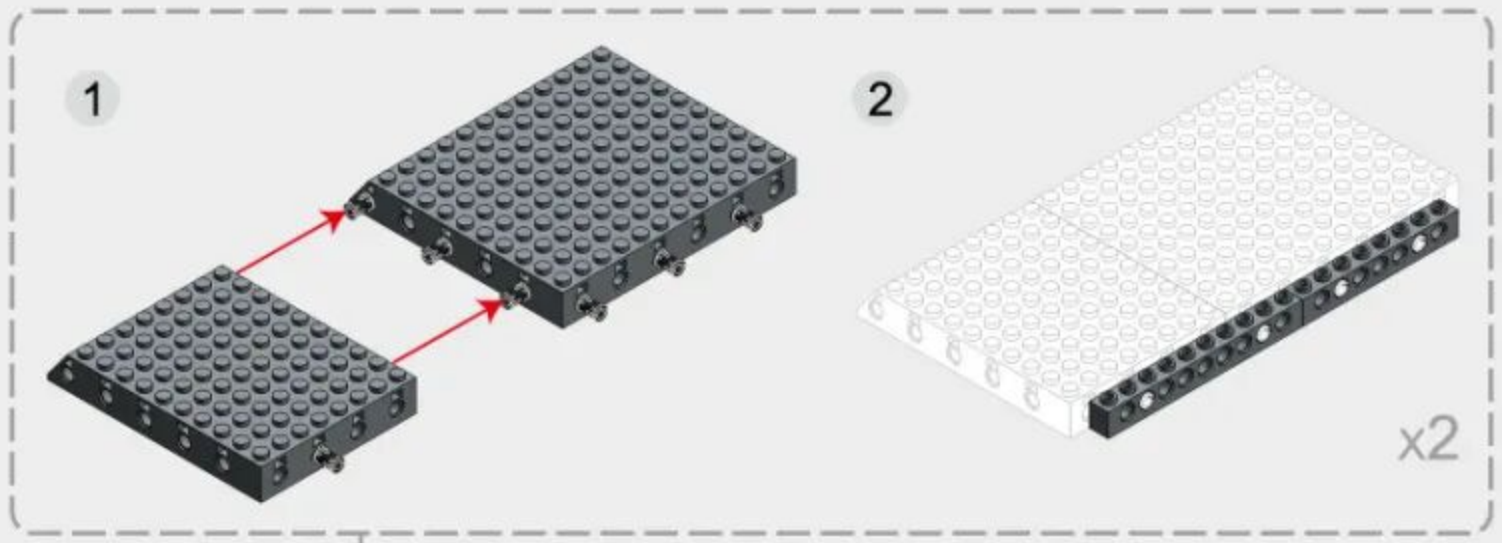
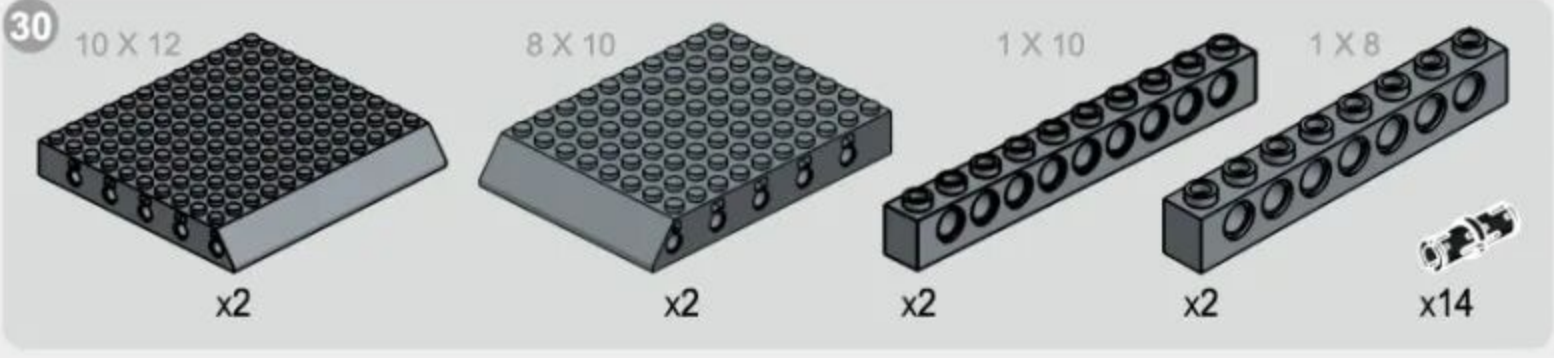

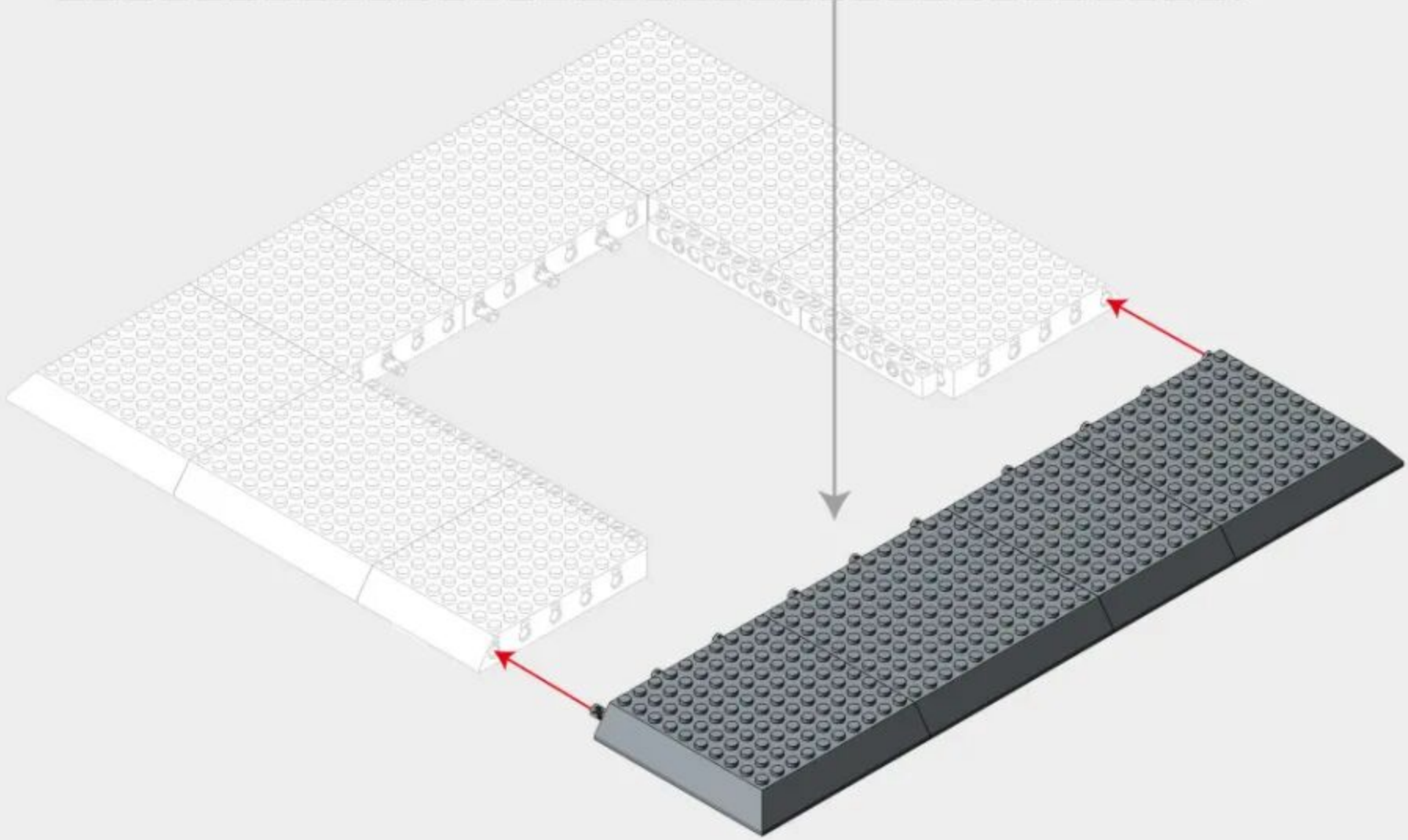
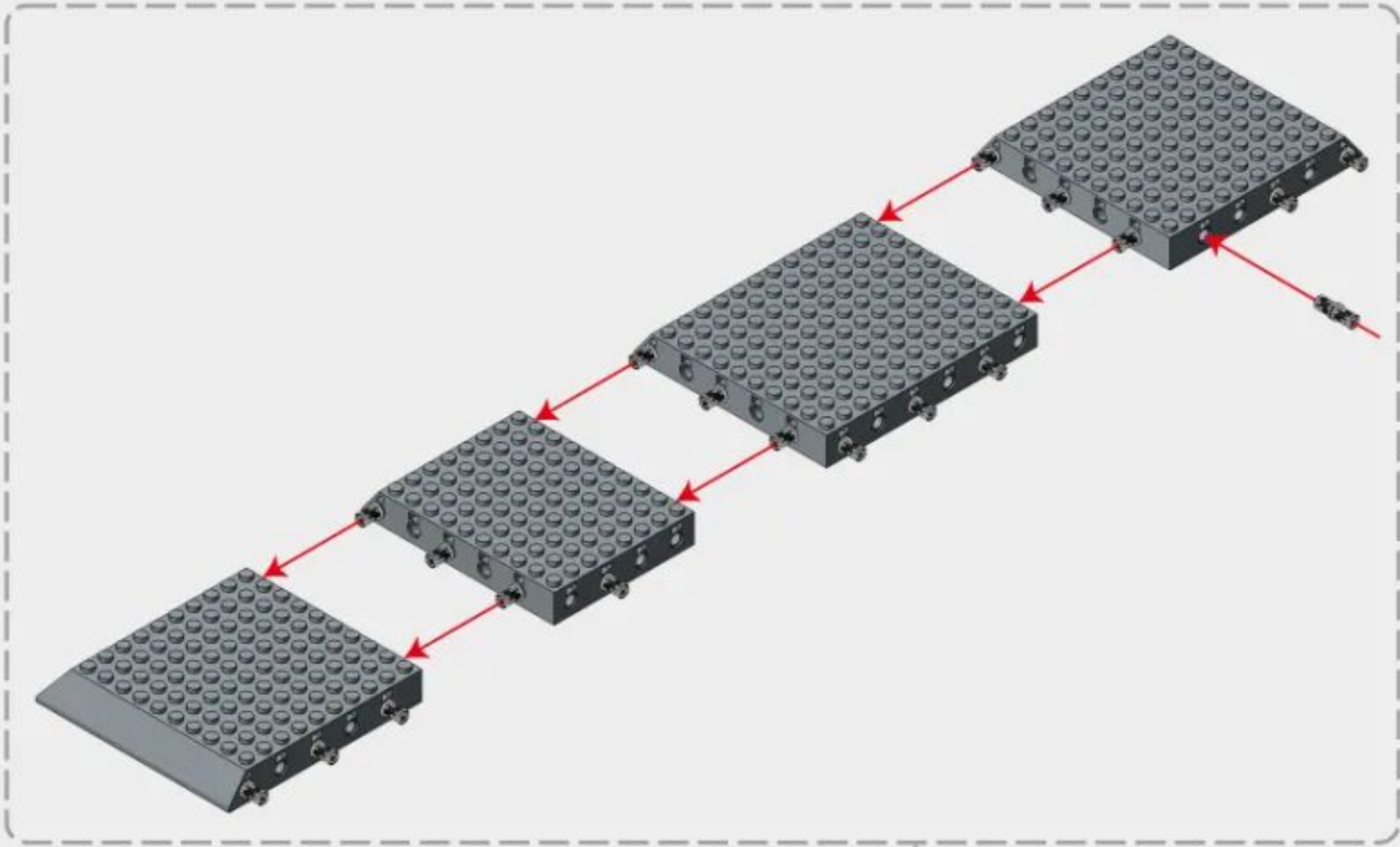
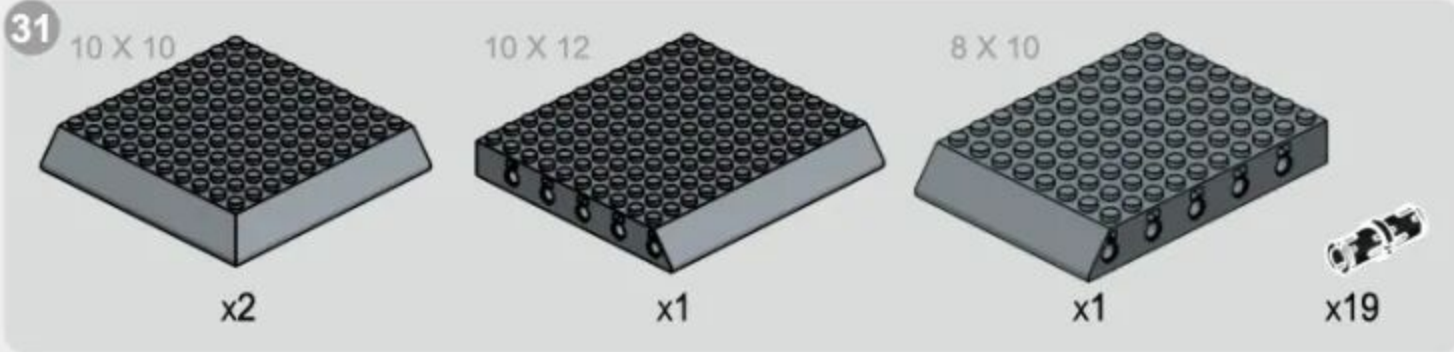

32

1 X 8

1 X 10

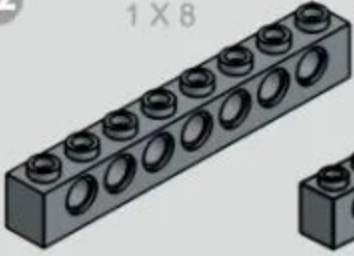

x2

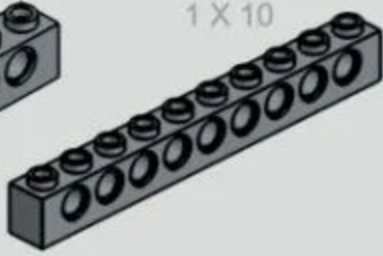

x2

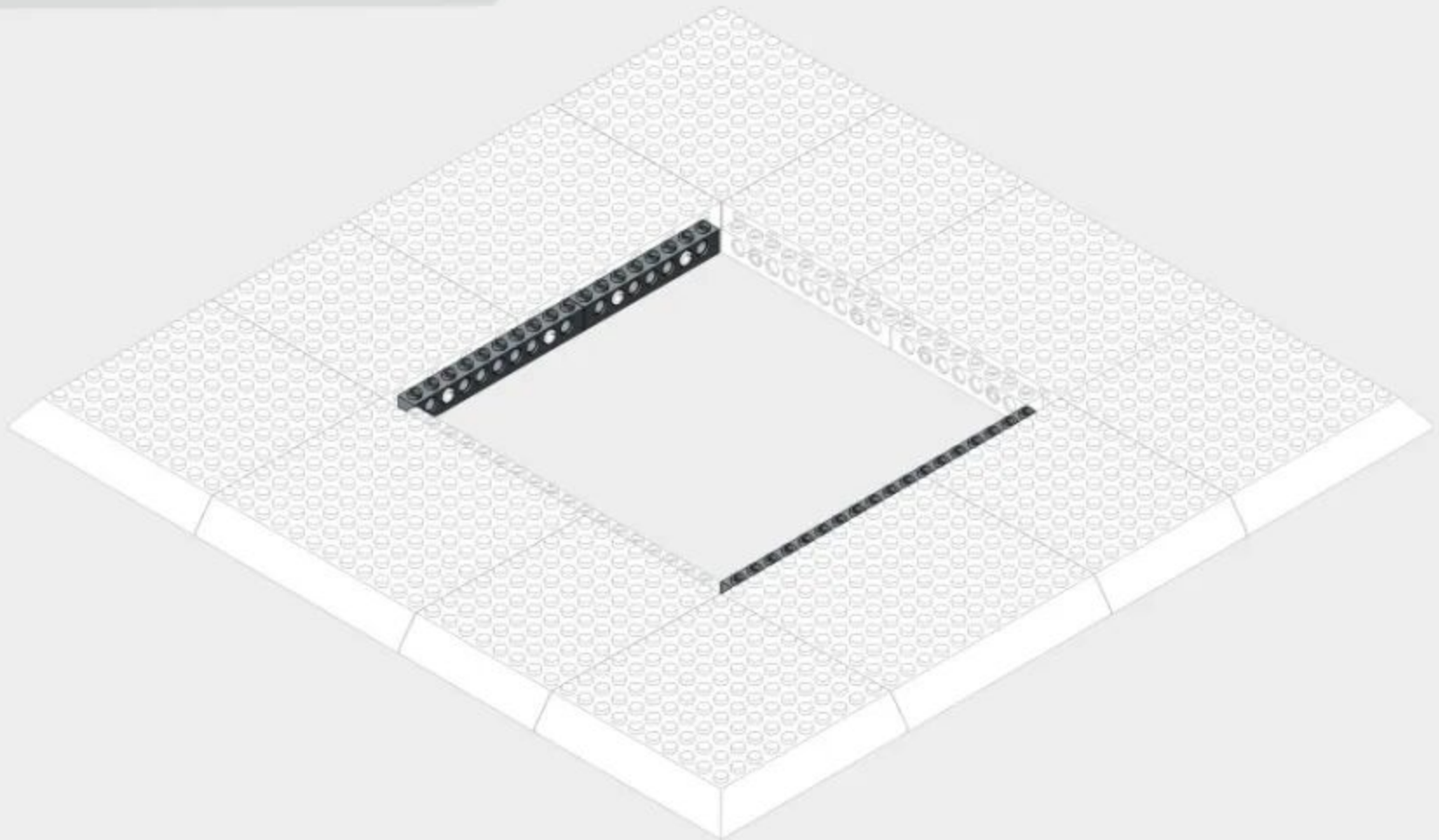

33

2 X 10

2 X 8

4 X 12

8 X 12

1 X 6

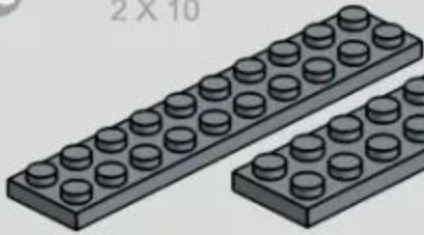

x4

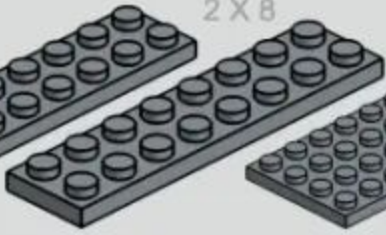

x2

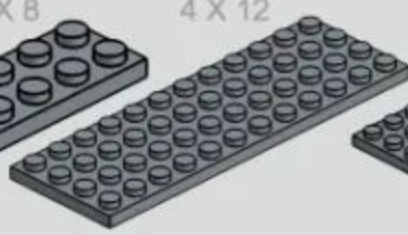

x1



x2

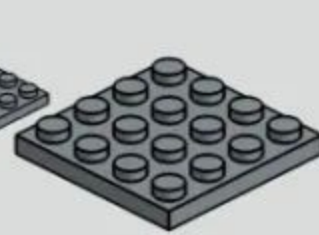

x1

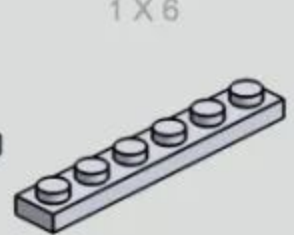

x4



x6



x12

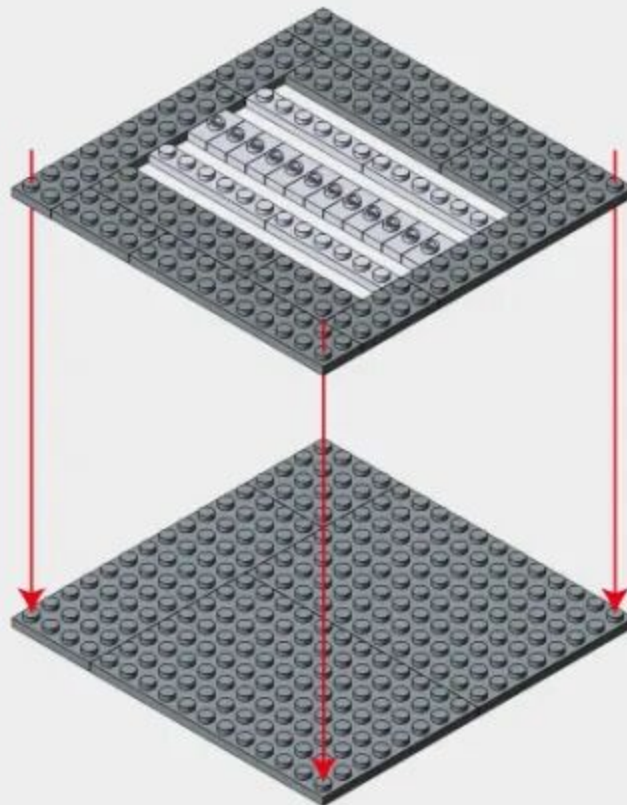

34

4 X 12

2 X 8

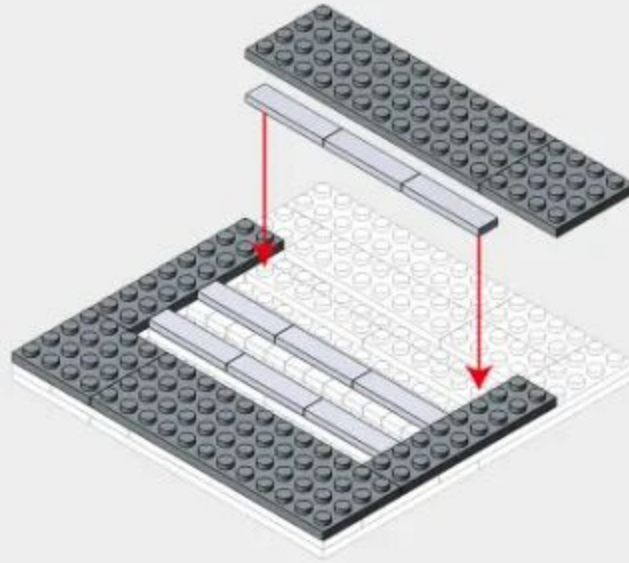
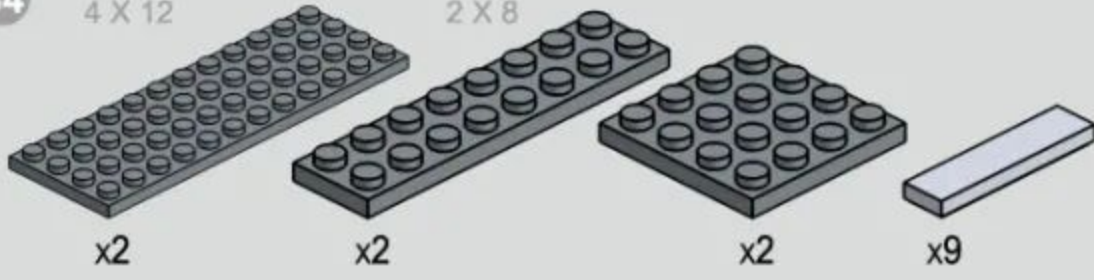

35

28 + 38

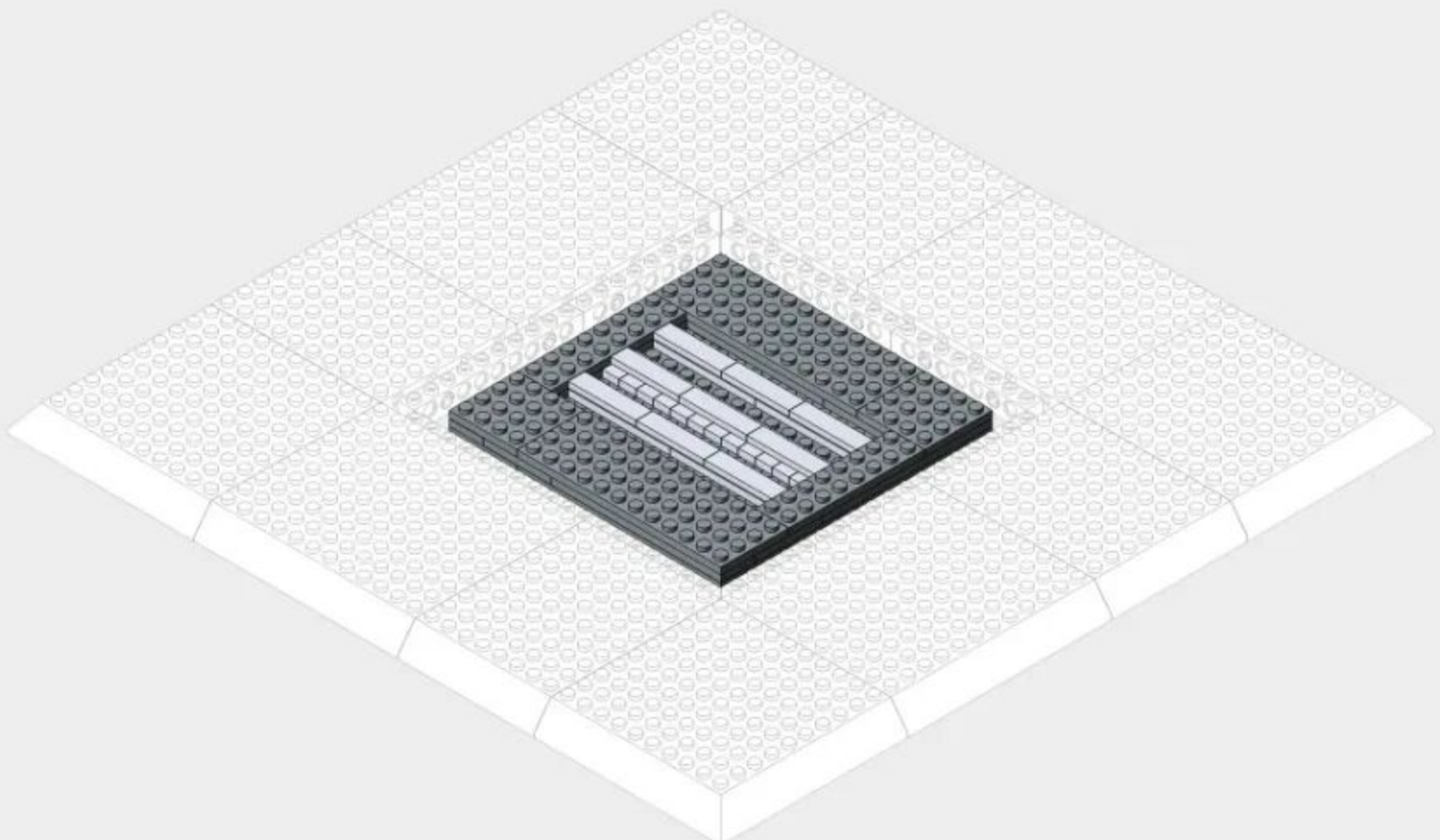

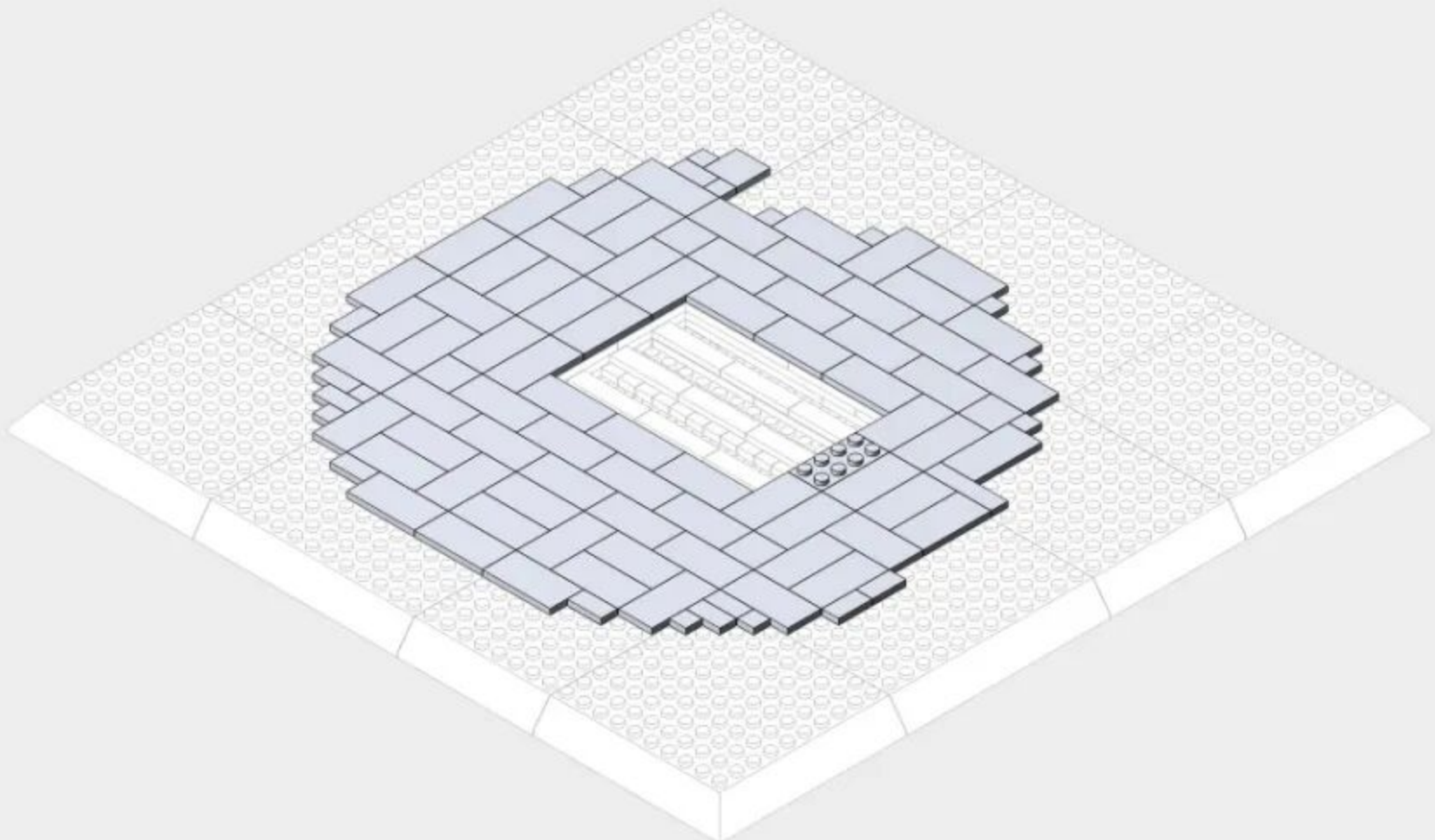
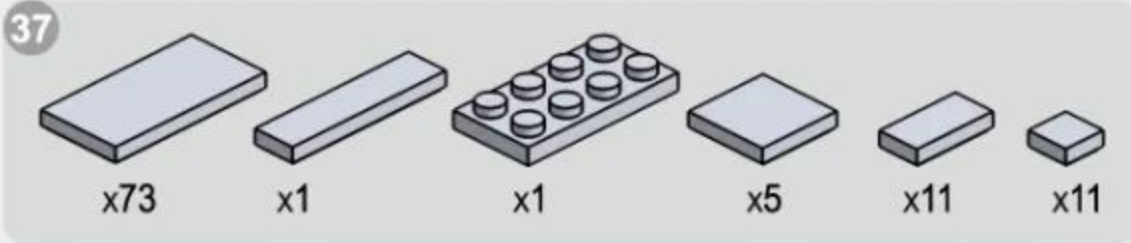
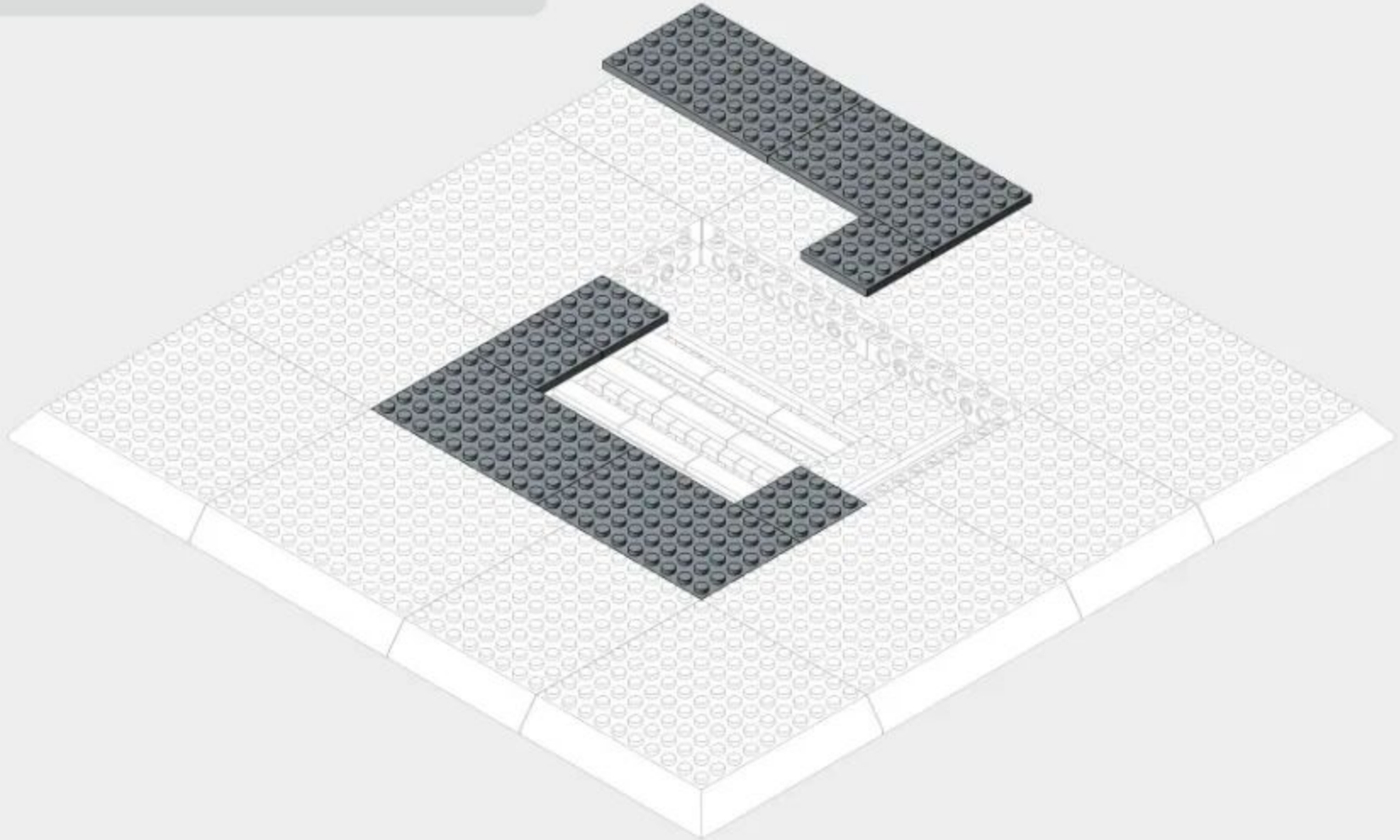
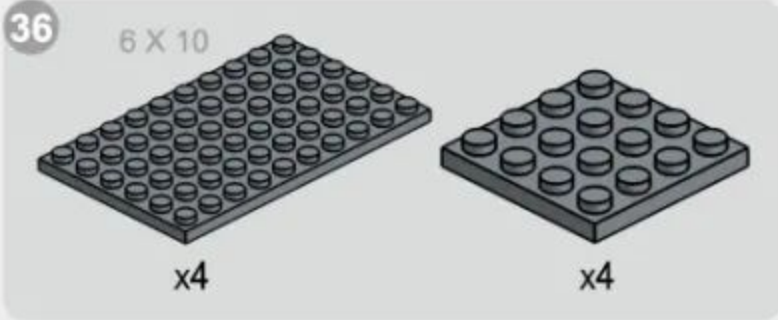

38

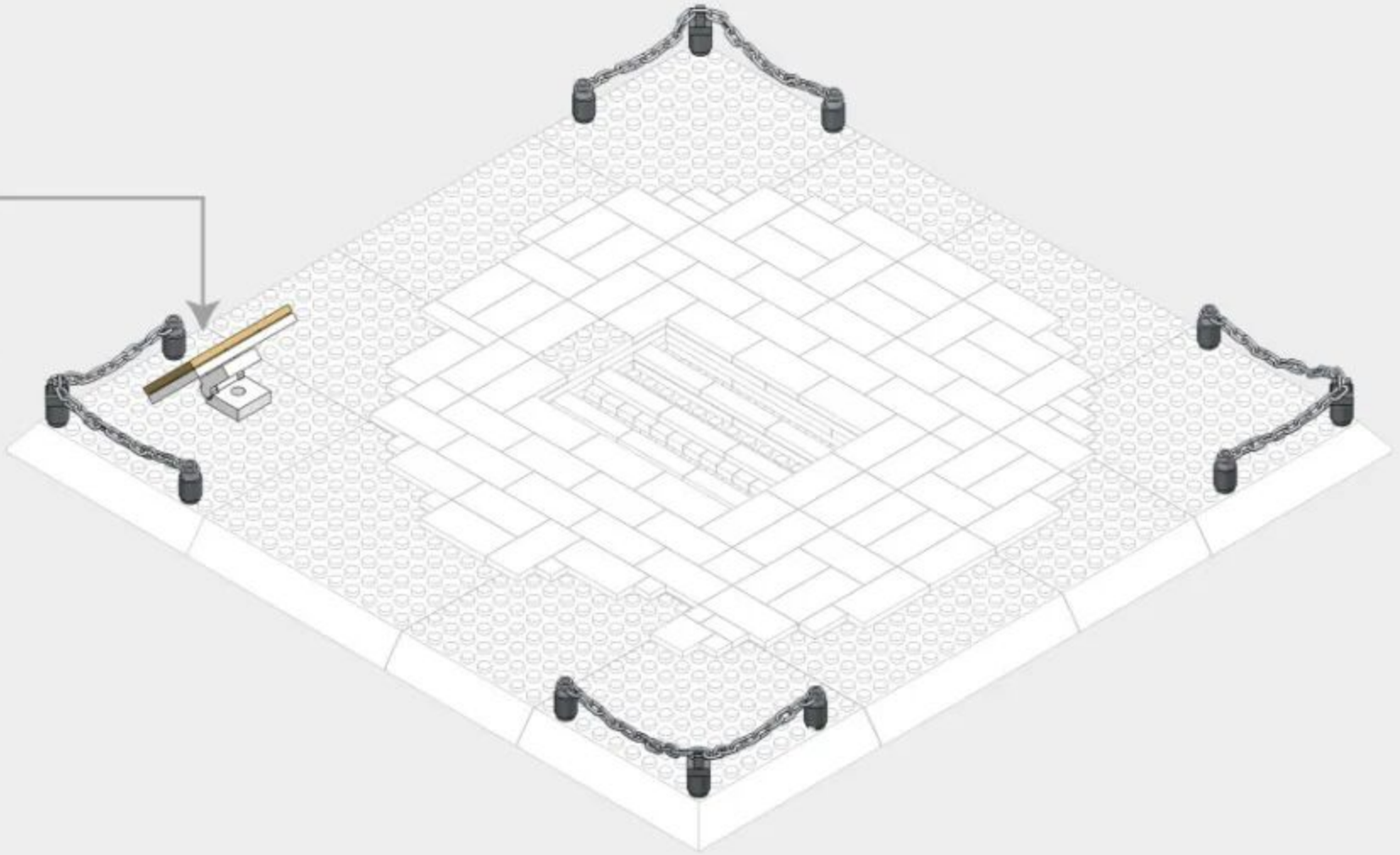
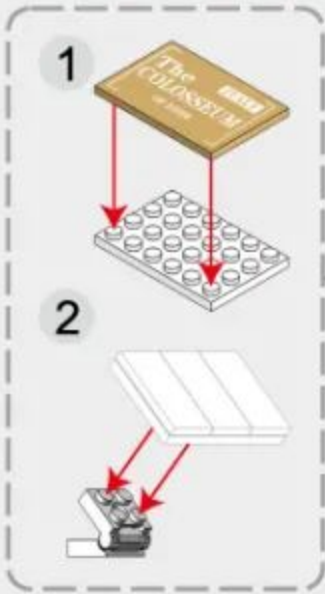
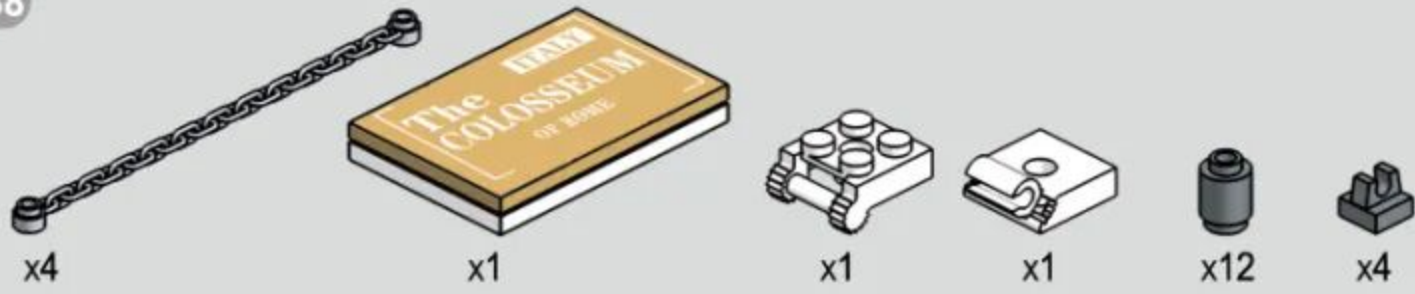

39

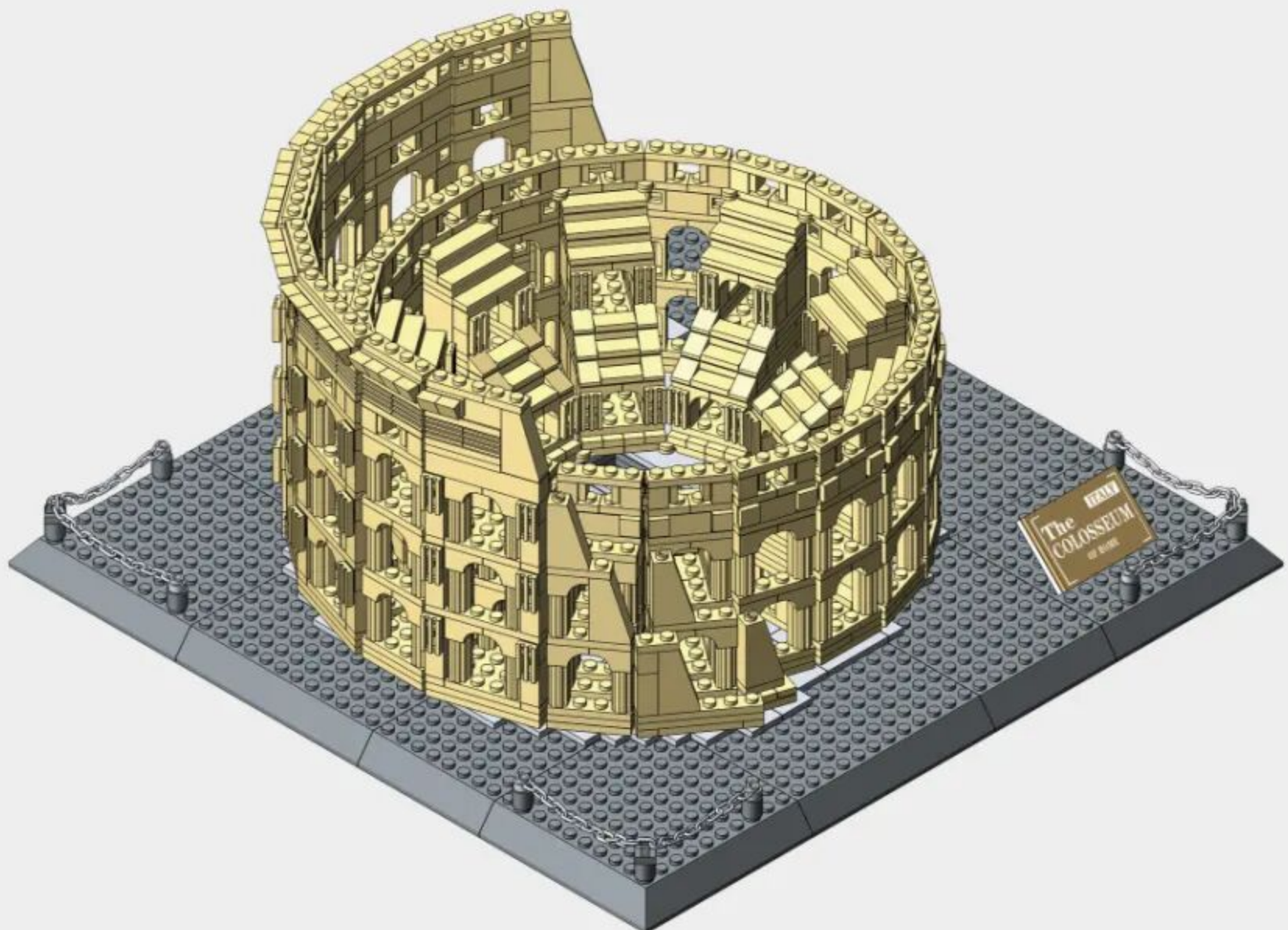

ARCHITECTURE

The World's great architecture

Shaping Skills Imagination & Curiosity Mathematical Self Discovery & Perception Parent-Child Interaction Problem Solving Creativity



✦ THE NIOMON OF KYOTO
Item NO.6212 50X40X11.6MM 2409PCS
京都仁王门



✦ THE COLOSSEUM OF ROME
Item NO.5225 45X30X9MM 1758PCS
罗马斗兽场



✦ THE STATUE OF LIBERTY
Item NO.5227 50X35X8MM 1686PCS
纽约自由女神



✦ THE YELLOW CRANE TOWER OF WUHAN
Item NO.6214 50X40X11.6MM 2912PCS
黄鹤楼



✦ GREAT PYRAMIDS OF GIZA
Item NO.4210 30X40X7MM 643PCS
埃及吉萨金字塔



✦ ELIZABETH TOWER
Item NO.4211 30X40X7MM 910PCS
英国伦敦伊丽莎白塔



✦ FONTANA DI TREVÌ
Item NO.4212 30X40X7MM 688PCS
罗马许愿池



✦ THE LOUVRE
Item NO.4213 30X40X7MM 821PCS
法国巴黎卢浮宫



✦ THE WHITE HOUSE
Item NO.4214 30X40X7MM 979PCS
美国华盛顿白宫



✦ THE CN TOWER-CANADA
Item NO.4215 30X40X7MM 400PCS
加拿大多伦多电视塔



✦ LINCOLN MEMORIAL
Item NO.4216 30X40X7MM 979PCS
美国林肯纪念馆



✦ MARINA BAY SANDS
Item NO.4217 30X40X7MM 881PCS
新加坡金沙酒店



✦ MERLION STATUE-SINGAPORE
Item NO.4218 30X40X7MM 503PCS
新加坡鱼尾狮雕像



✦ THE TOWER BRIDGE OF LODON
Item NO.4219 30X40X7MM 969PCS
伦敦塔桥



✦ FLATIRON BUILDING
Item NO.4220 30X40X7MM 838PCS
美国熨斗大厦



✦ NOTRE-DAME DE PARIS
Item NO.5210 45X30X9MM 1380PCS
法国巴黎圣母院大教堂



✦ **TAJ MAHAL OF AGRA**
Item NO.5211 45X30X9MM 1505PCS
印度阿格拉泰姬陵



✦ **EMPIRE STATE BUILDING**
Item NO.5212 45X30X9MM 1995PCS
美国纽约帝国大厦



✦ **PETRONAS TOWERS**
Item NO.5213 45X30X9MM 1160PCS
马来西亚吉隆坡国油双峰塔



✦ **THE LEANING TOWER**
Item NO.5214 45X30X9MM 1392PCS
意大利比萨斜塔



✦ **THE TOWER BRIDGE**
Item NO.5215 45X30X9MM 1033PCS
英国伦敦双子桥



✦ **THE BIG BEN**
Item NO.5216 45X30X9MM 1642PCS
英国伦敦大笨钟



✦ **THE EIFFEL TOWER**
Item NO.5217 45X30X9MM 978PCS
法国巴黎埃菲尔铁塔



✦ **THE ORIENTAL PEARL TOWER**
Item NO.5224 45X30X9MM 1109PCS
中国上海东方明珠



✦ **THE TIAN AN MEN**
Item NO.5218 45X30X9MM 758PCS
中国北京天安门



✦ **THE SPASSKAYA TOWER**
Item NO.5219 45X30X9MM 1044PCS
俄罗斯克里姆林宫



✦ **THE BURJAL ARAB HOTEL**
Item NO.5220 45X30X9MM 1307PCS
迪拜帆船酒店



✦ **THE TAIPEI 101**
Item NO.5221 45X30X9MM 1511PCS
中国台北101大楼



✦ **THE TEMPLE OF HEAVEN**
Item NO.5222 45X30X9MM 1052PCS
中国北京故宫天坛



✦ **THE GOLDEN GATE BRIDGE**
Item NO.6210 54X42X10MM 1977PCS
美国旧金山金门大桥



✦ **THE BRANDENBURG**
Item NO.6211 54X42X10MM 1552PCS
德国勃兰登堡门



✦ **THE IMPERIAL HOTEL**
Item NO.5226 500X350X80MM 1375PCS
东京帝国饭店



✦ **THE TRIUMPHAL ARCH**
Item NO.5223 45X30X9MM 1401PCS
法国巴黎凯旋门

THE COLOSSEUM

OF ROME

INTRODUCTION

The Colosseum or Coliseum, also known as the Flavian Amphitheatre (Latin: Amphitheatrum Flavium; Italian: Anfiteatro Flavio or Colosseo), is an oval amphitheatre in the centre of the city of Rome, Italy. Built of travertine, tuff, and brick-faced concrete, it is the largest amphitheatre ever built. The Colosseum is situated just east of the Roman Forum. Construction began under the emperor Vespasian in AD 72 and was completed in AD 80 under his successor and heir, Titus. Further modifications were made during the reign of Domitian. These three emperors are known as the Flavian dynasty, and the amphitheatre was named in Latin for its association with their family name (Flavius). The Colosseum could hold, it is estimated, between 50,000 and 80,000 spectators, having an average audience of some 65,000; it was used for gladiatorial contests and public spectacles such as mock sea battles (for only a short time as the hypogeum was soon filled in with mechanisms to support the other activities), animal hunts, executions, re-enactments of famous battles, and dramas based on Classical mythology. The building ceased to be used for entertainment in the early medieval era. It was later reused for such purposes as housing, workshops, quarters for a religious order, a fortress, a quarry, and a Christian shrine.

