



THE STATUE OF LIBERTY OF NEW YORK

Estatua de la Libertad

America

The world's great architecture

Ages

6+



Creative Ability

Family Interaction

Observation Ability

Thinking Ability

Practical Ability



USA
The STATUE OF LIBERTY
OF NEW YORK

NO.5227
1577 PCS

Perseverance

积木匠心·颗粒匠者



The Temple of Heaven



The Eiffel Tower



The Brandenburg Gate



The Leaning Tower Of Pisa



The Taj Mahal



The Big Ben



The White House



The Burj Al-Arab Hotel



The Golden Gate Bridge



The CN Tower



The Spasskaya Tower



The Triumphal Arch

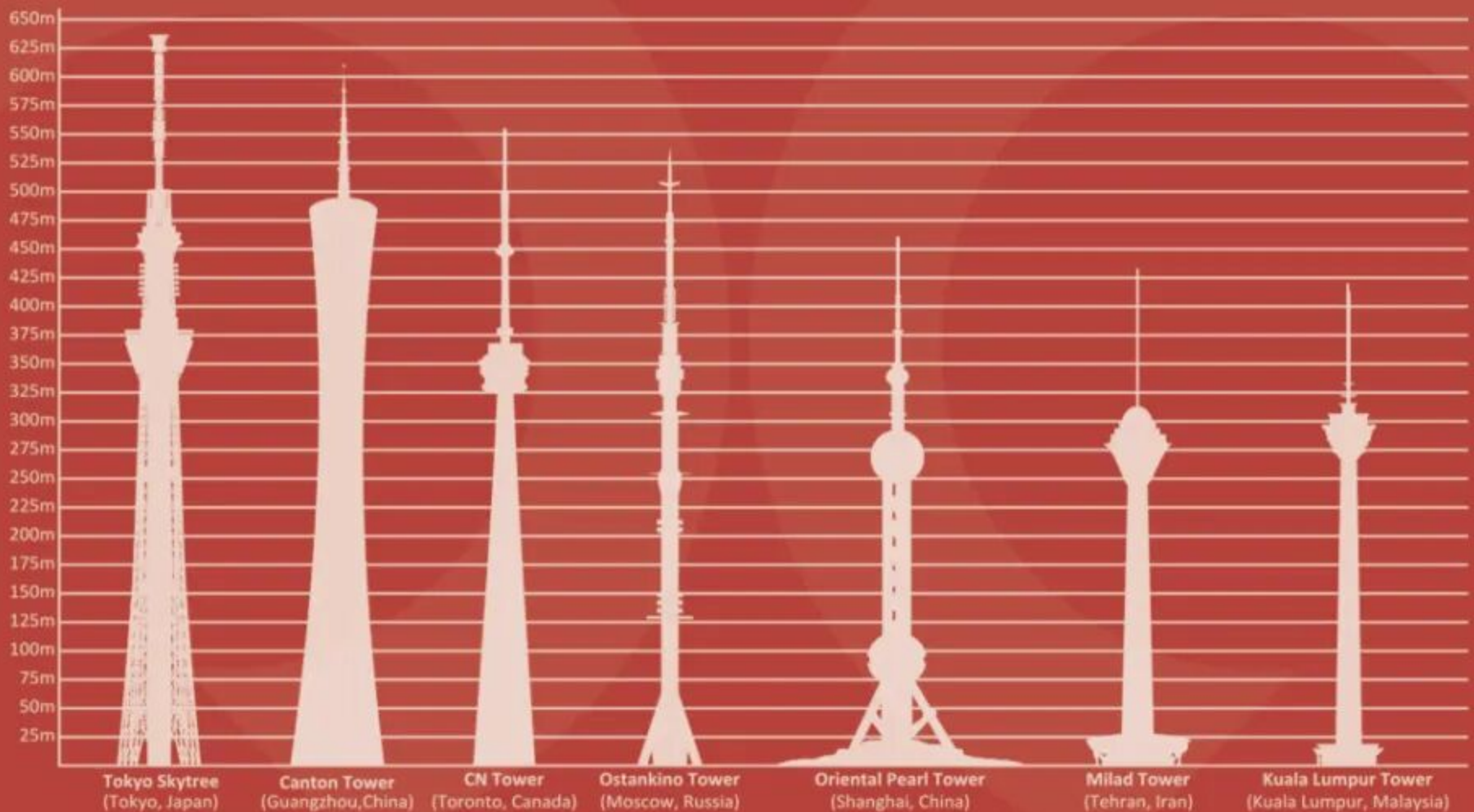



It will be a city...

这将构成一座城市...

Architecture

Structure

剖析结构与实物数据比例

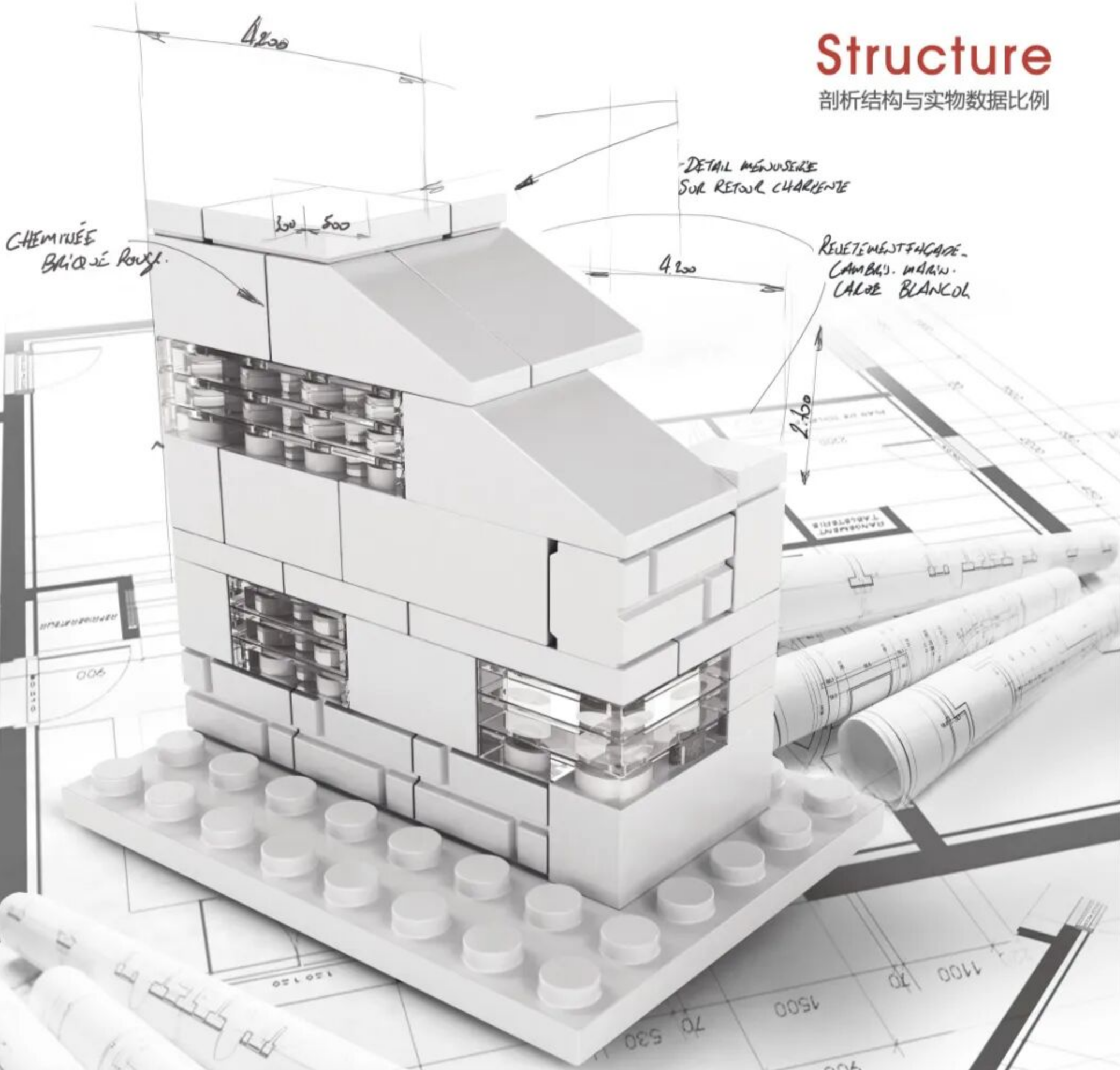

Anatomy

Analyze the ratio of product structure to physical data



Building Block

The world's great architecture
3D construction

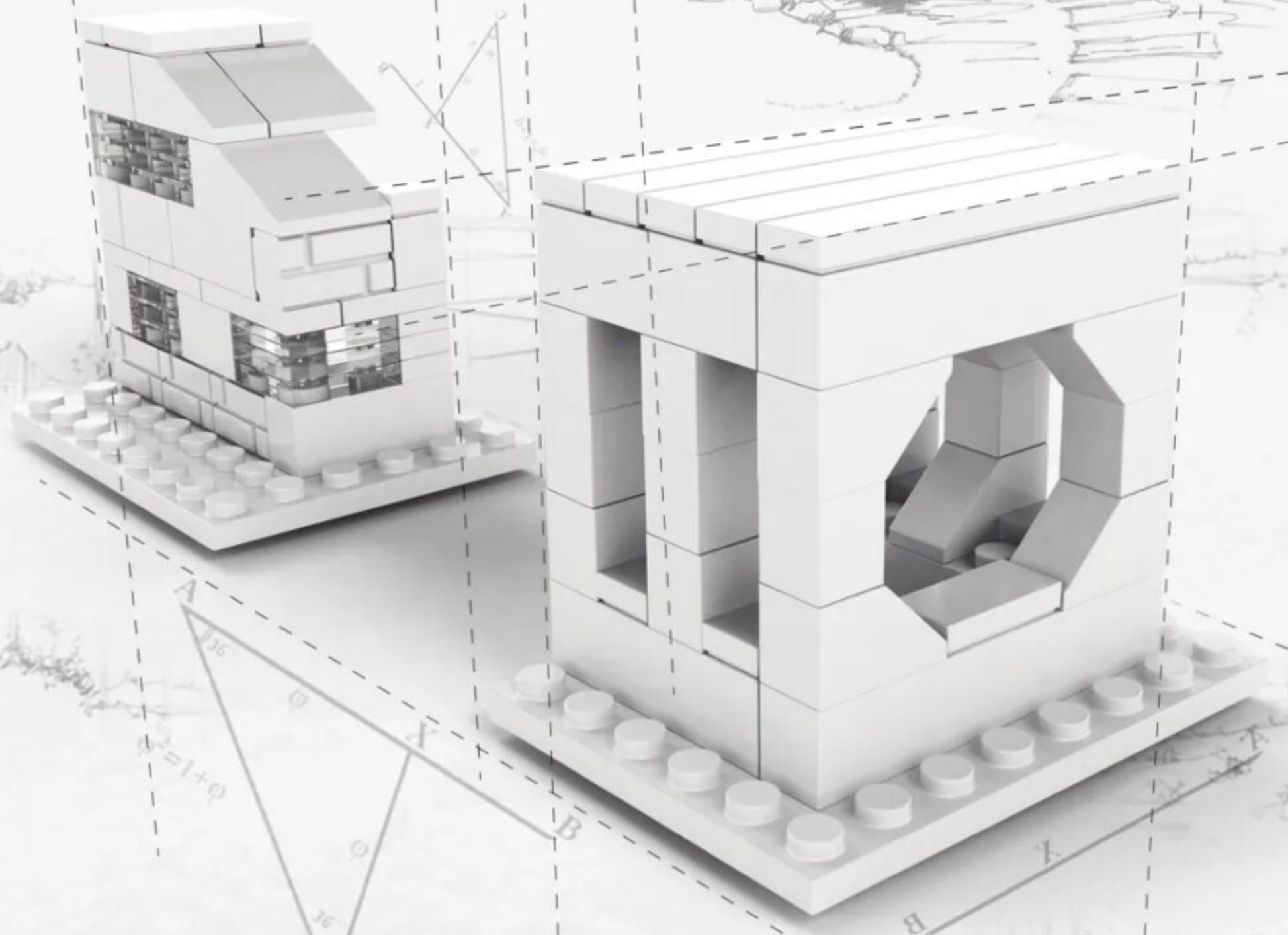

proportion

对产品精确分析运用3维技术最大限度还原实物比例

Accurate analysis of the product, using 3D technology to maximize the reduction of physical objects.

Creativity

外观设计结合黄金比例更好展现美感

$$\varphi = \frac{a+b}{a} = \frac{a}{b} = 1,61803398875$$



DETAIL MENUSELERE
SUR RETOUR CHARENTE

RENETEMENT FACADE -
CAMBRI. MARIN -
CALOE BLANCOL

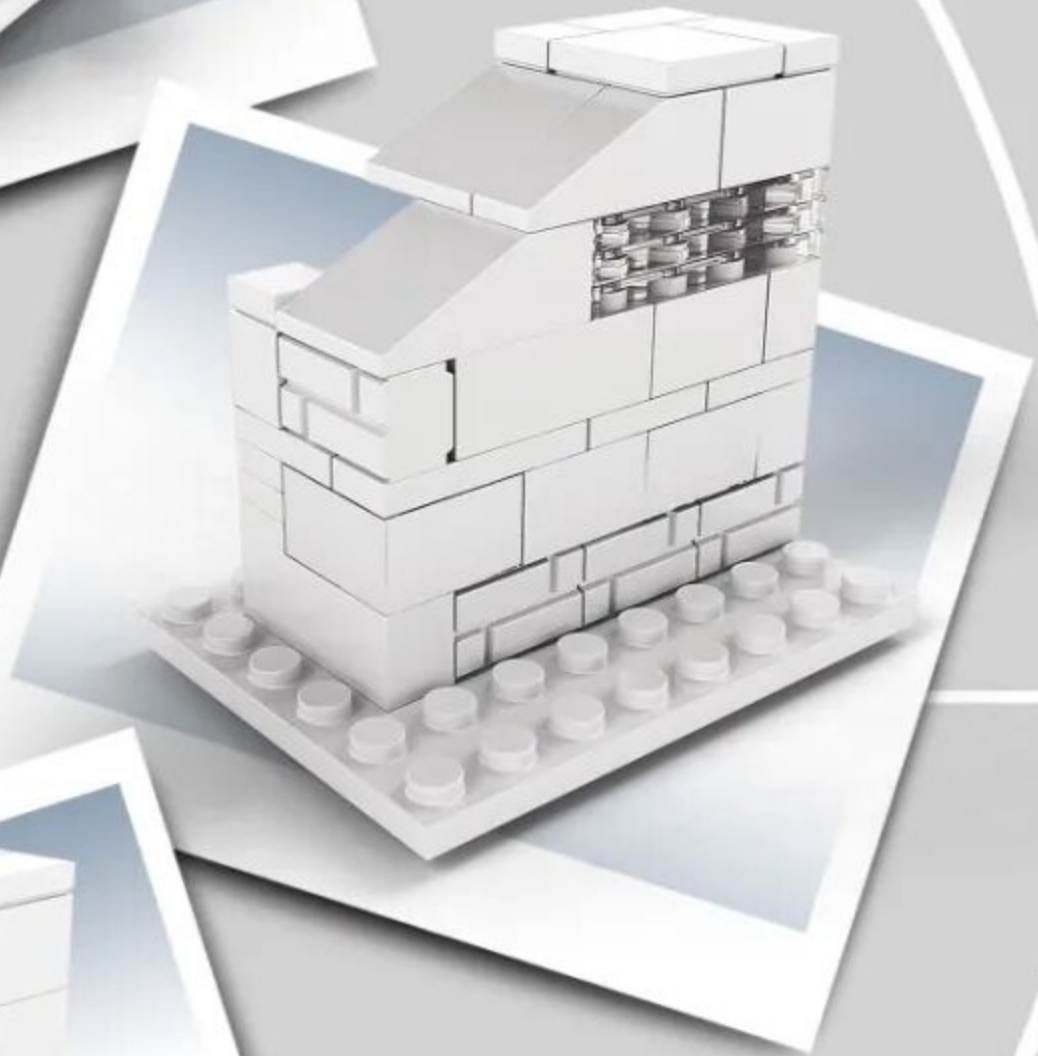

CHEMINÉE
Brique rouge.



Architecture

Use the golden ratio in the design and development of the product to better show the beauty of the product.

Brickseparator

积木起件器使用说明

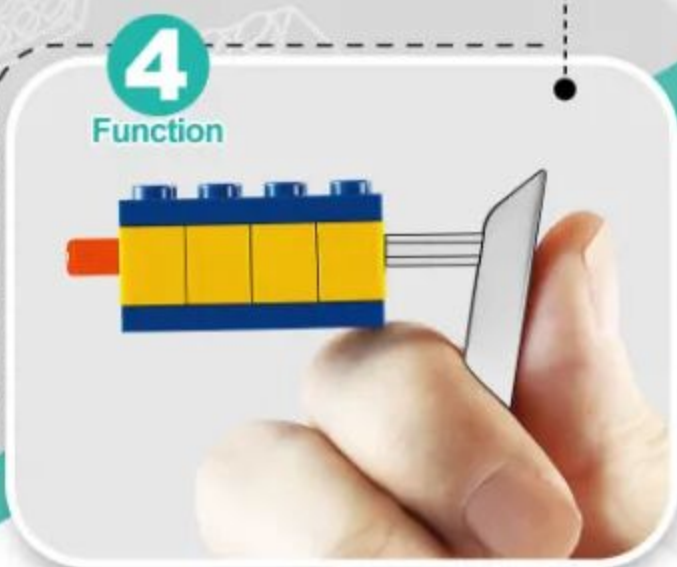
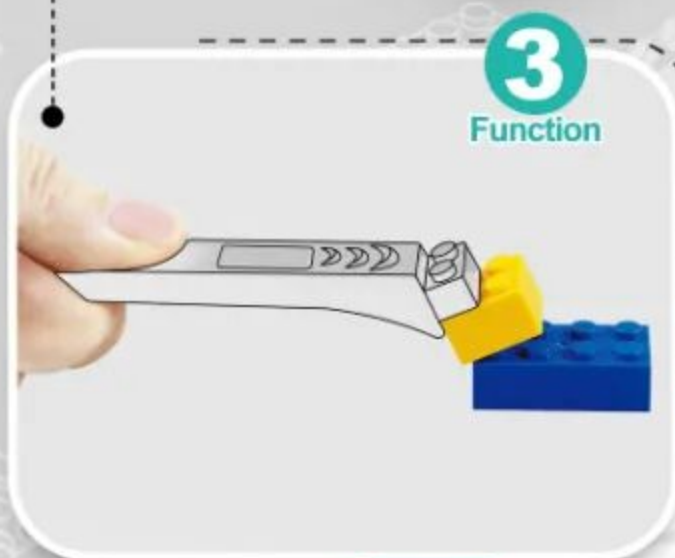
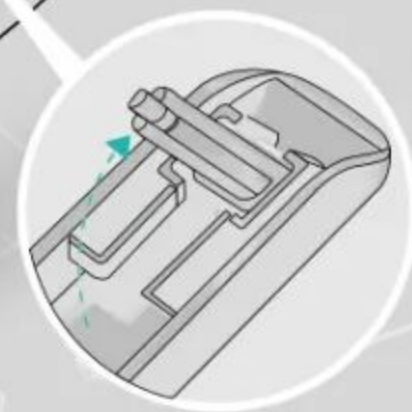
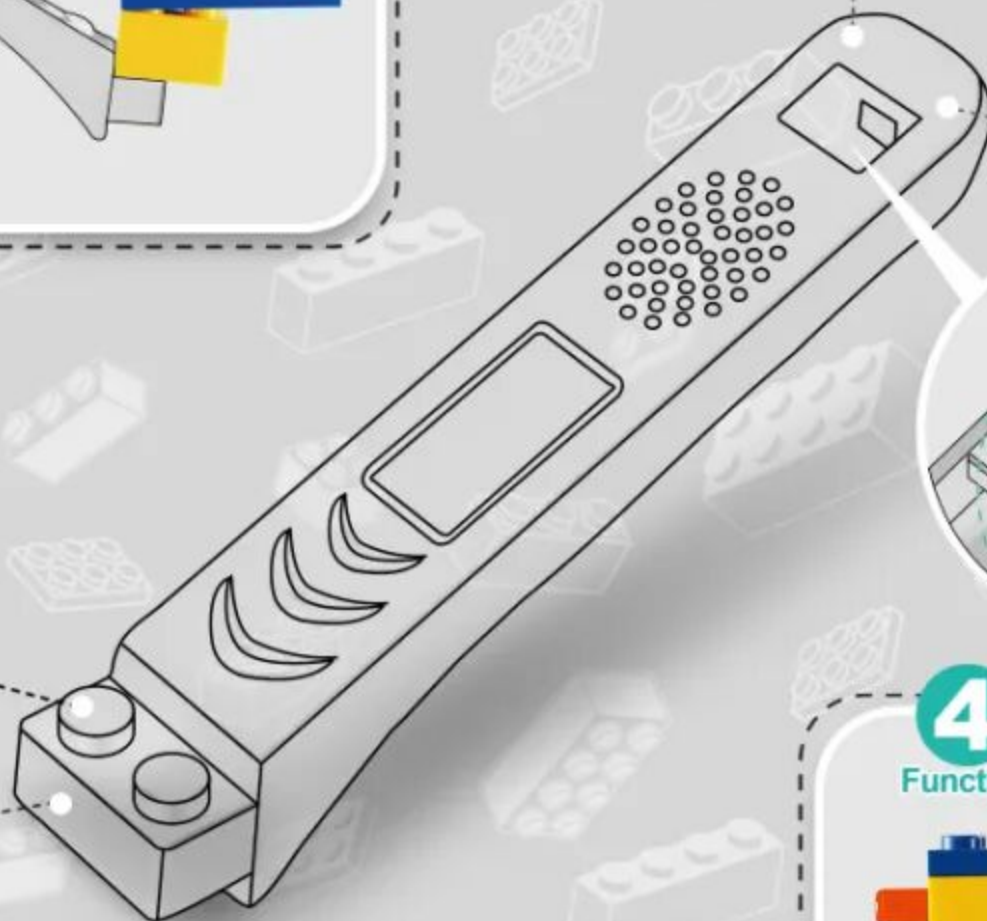
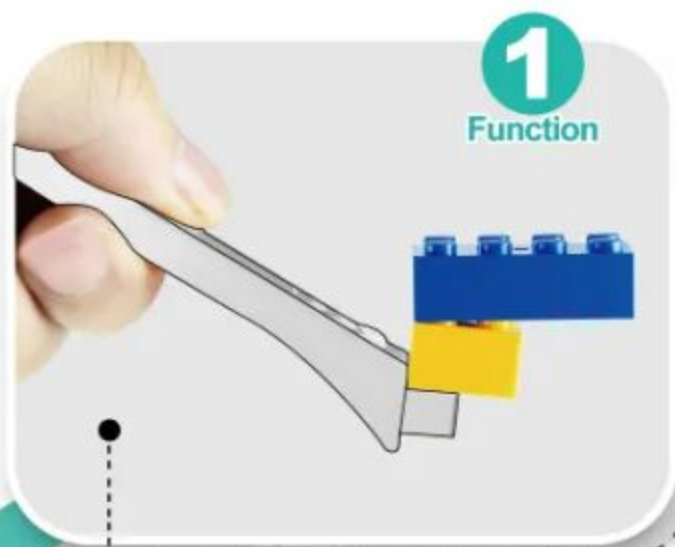

4 ways to make installation easier
让安装更简单

Building Blocks

拼装小技巧



- First open the product packaging according to the instructions.

按指导用正确方式拆解产品外包装。



- Summarize all parts to count the number of familiar accessories.

拆开积木包装对照说明书清单确认积木数量。



- Arranging all accessories by color helps to quickly install the product.

把确认好的积木以颜色进行分类排好以便安装。



- Carefully install the product and learn about building.

按说明书步骤拼装并完成你的积木模型。

INSTALLATION
TIPS

1:1 Physical Reference Table

1:1

Instructions For Use

让安装更简单

十字棒配件1:1尺寸参照表



2 $(1 \times 2) = 2$

3 $(1 \times 3) = 3$

4 $(1 \times 4) = 4$

5 $(1 \times 5) = 5$

6 $(1 \times 6) = 6$

7 $(1 \times 7) = 7$

8 $(1 \times 8) = 8$

9 $(1 \times 9) = 9$

10 $(1 \times 10) = 10$

12 $(1 \times 12) = 12$

16 $(1 \times 16) = 16$

The Statue of Liberty of
new york
America



Front



Left



Back



Product Size: 177X177x464mm





自由女神

The Statue of Liberty ■ of new york America

The contents of this chapter refer to the Wikipedia website.

本章内容参考维基百科网站，更多资讯可自行查阅。

The world's great architecture

About The Building



The Statue of Liberty

The Statue of Liberty (Liberty Enlightening the World; French: La Liberté éclairant le monde) is a colossal neoclassical sculpture on Liberty Island in New York Harbor in New York, in the United States. The copper statue, a gift from the people of France to the people of the United States, was designed by French sculptor Frédéric Auguste Bartholdi and its metal framework was built by Gustave Eiffel. The statue was dedicated on October 28, 1886. The statue is a figure of Libertas, a robed Roman liberty goddess. She holds a torch above her head with her right hand, and in her left hand carries a tabula ansata inscribed JULY IV (July 4, 1776 in Roman numerals), the date of the U.S. Declaration of Independence. A broken shackle and chain lie at her feet as she walks forward, commemorating the recent national abolition of slavery. After its dedication, the statue became an icon of freedom and of the United States; it has been a welcoming sight to immigrants arriving by sea.

Design and construction process



According to the National Park Service, the idea of a monument presented by the French people to the United States was first proposed by Édouard René de Laboulaye, president of the French Anti-Slavery Society and a prominent and important political thinker of his time. The project is traced to a mid-1865 conversation between Laboulaye, a staunch abolitionist, and Frédéric Bartholdi, a sculptor. In after-dinner conversation at his home near Versailles, Laboulaye, an ardent supporter of the Union in the American Civil War, is supposed to have said: "If a monument should rise in the United States, as a memorial to their independence, I should think it only natural if it were built by united effort—a common work of both our nations." The National Park Service, in a 2000 report, however, deemed this a legend traced to an 1885 fundraising pamphlet, and that the statue was most likely conceived in 1870. In another essay on their website, the Park Service suggested that Laboulaye was minded to honor the Union victory and its consequences, "With the abolition of slavery and the Union's victory in the Civil War in 1865, Laboulaye's wishes of freedom and democracy were turning into a reality in the United States. In order to honor these achievements, Laboulaye proposed that a gift be built for the United States on behalf of France. Laboulaye hoped that by calling attention to the recent achievements of the United States, the French people would be inspired to call for their own democracy in the face of a repressive monarchy."



According to sculptor Frédéric Auguste Bartholdi, who later recounted the story, Laboulaye's alleged comment was not intended as a proposal, but it inspired Bartholdi. Given the repressive nature of the regime of Napoleon III, Bartholdi took no immediate action on the idea except to discuss it with Laboulaye. Bartholdi was in any event busy with other possible projects; in the late 1860s, he approached Isma'il Pasha, Khedive of Egypt, with a plan to build Progress or Egypt Carrying the Light to Asia, a huge lighthouse in the form of an ancient Egyptian female fellah or peasant, robed and holding a torch aloft, at the northern entrance to the Suez Canal in Port Said. Sketches and models were made of the proposed work, though it was never erected. There was a classical precedent for the Suez proposal, the Colossus of Rhodes: an ancient bronze statue of the Greek god of the sun, Helios. This statue is believed to have been over 100 feet (30 m) high, and it similarly stood at a harbor entrance and carried a light to guide ships. Both the khedive and Lesseps declined the proposed statue from Bartholdi, citing the expensive cost. The Port Said Lighthouse was built instead, by François Coignet in 1869.

Design, style, and symbolism

Bartholdi and Laboulaye considered how best to express the idea of American liberty. In early American history, two female figures were frequently used as cultural symbols of the nation. One of these symbols, the personified Columbia, was seen as an embodiment of the United States in the manner that Britannia was identified with the United Kingdom and Marianne came to represent France. Columbia had supplanted the traditional European personification of the Americas as an "Indian princess", which had come to be regarded as uncivilized and derogatory toward Americans. The other significant female icon in American culture was a representation of Liberty, derived from Libertas, the goddess of freedom widely worshipped in ancient Rome, especially among emancipated slaves. A Liberty figure adorned most American coins of the time, and representations of Liberty appeared in popular and civic art, including Thomas Crawford's Statue of Freedom (1863) atop the dome of the United States Capitol Building.



Artists of the 18th and 19th centuries striving to evoke republican ideals commonly used representations of Libertas as an allegorical symbol. A figure of Liberty was also depicted on the Great Seal of France. However, Bartholdi and Laboulaye avoided an image of revolutionary liberty such as that depicted in Eugène Delacroix's famed *Liberty Leading the People* (1830). In this painting, which commemorates France's July Revolution, a half-clothed Liberty leads an armed mob over the bodies of the fallen. Laboulaye had no sympathy for revolution, and so Bartholdi's figure would be fully dressed in flowing robes. Instead of the impression of violence in the Delacroix work, Bartholdi wished to give the statue a peaceful appearance and chose a torch, representing progress, for the figure to hold.

Main Color Matching

配色方案



Pantone 2407C

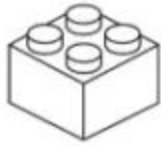

Pantone 7500C

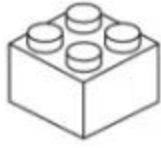

Pantone 431C

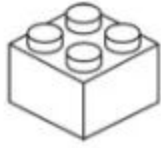

Pantone Cool Gray 6C

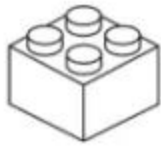

Pantone Black 6C

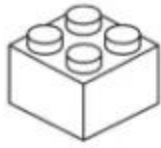

Color matching

Adopting 4 main colors, red, brown and green as the main color, the more reasonable and bold color matching on the original building, making the product more atmospheric and the whole design is more reasonable.

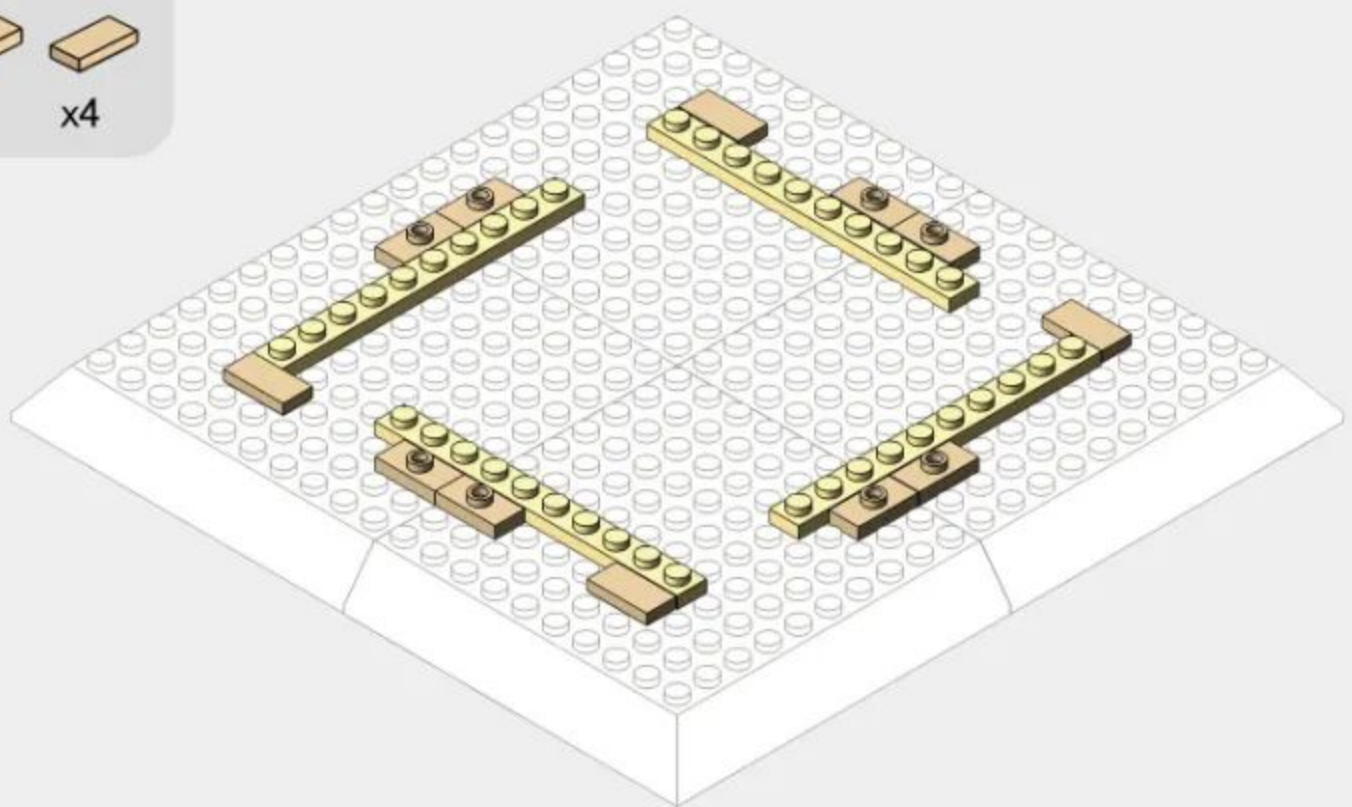
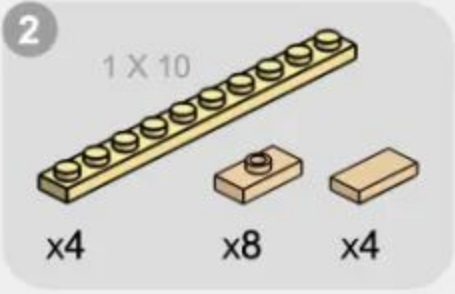
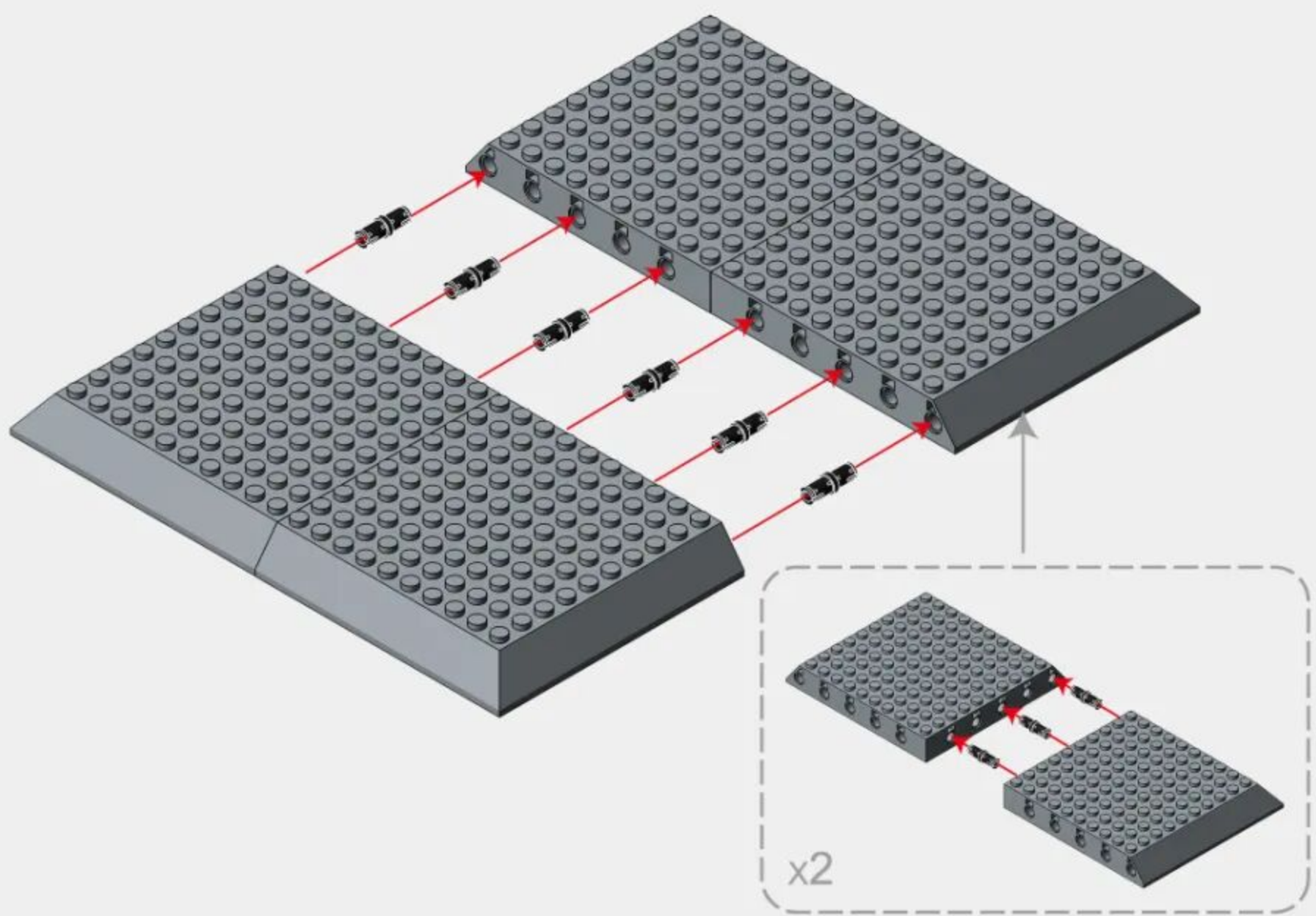
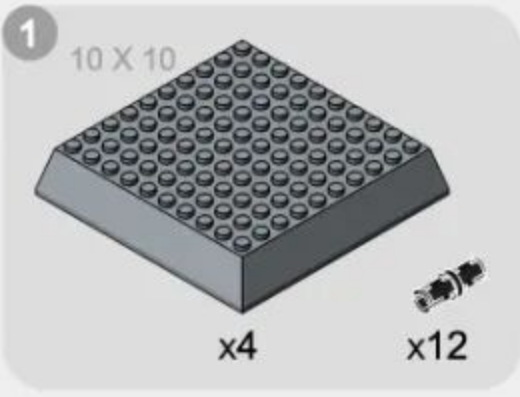

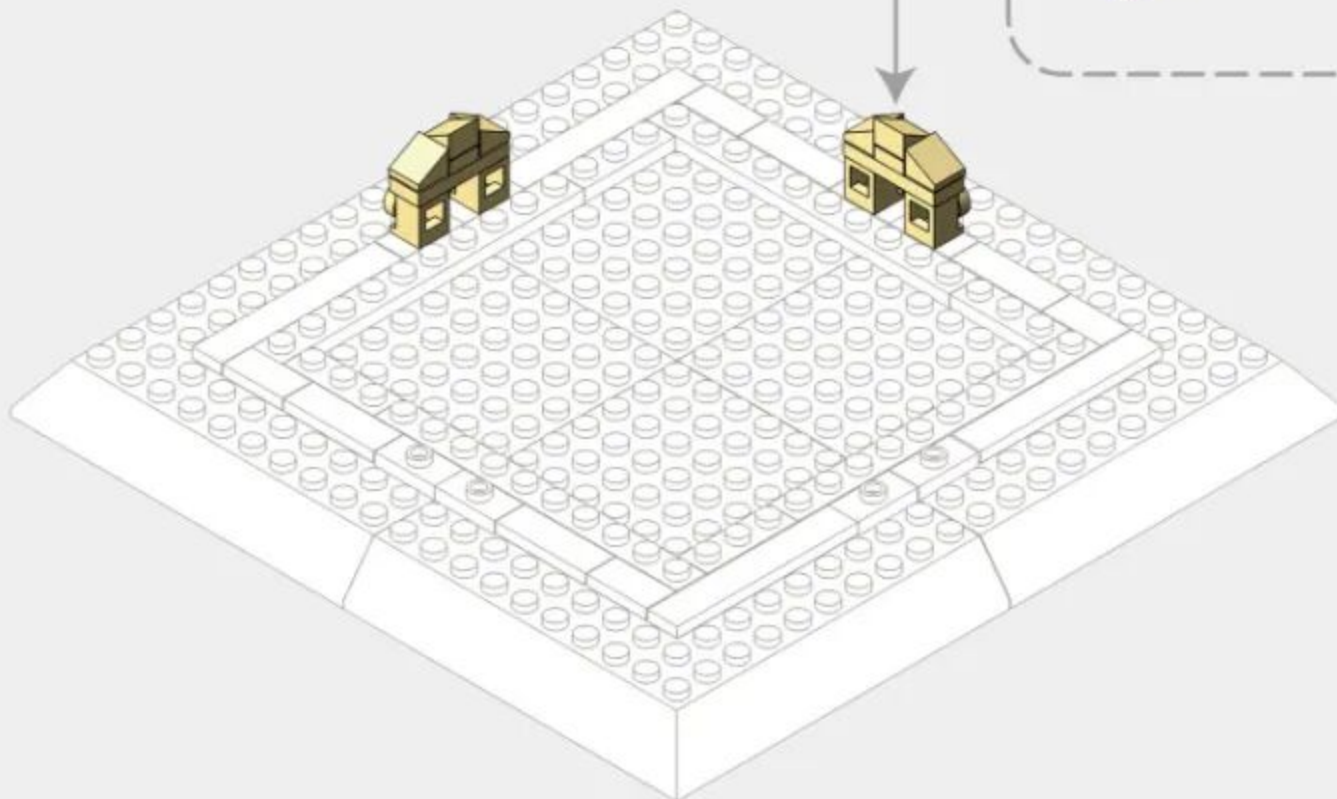
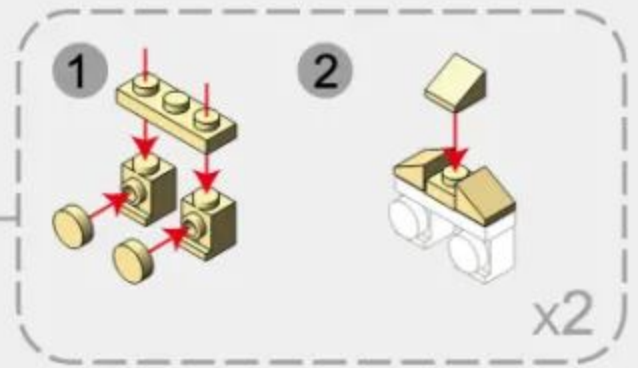
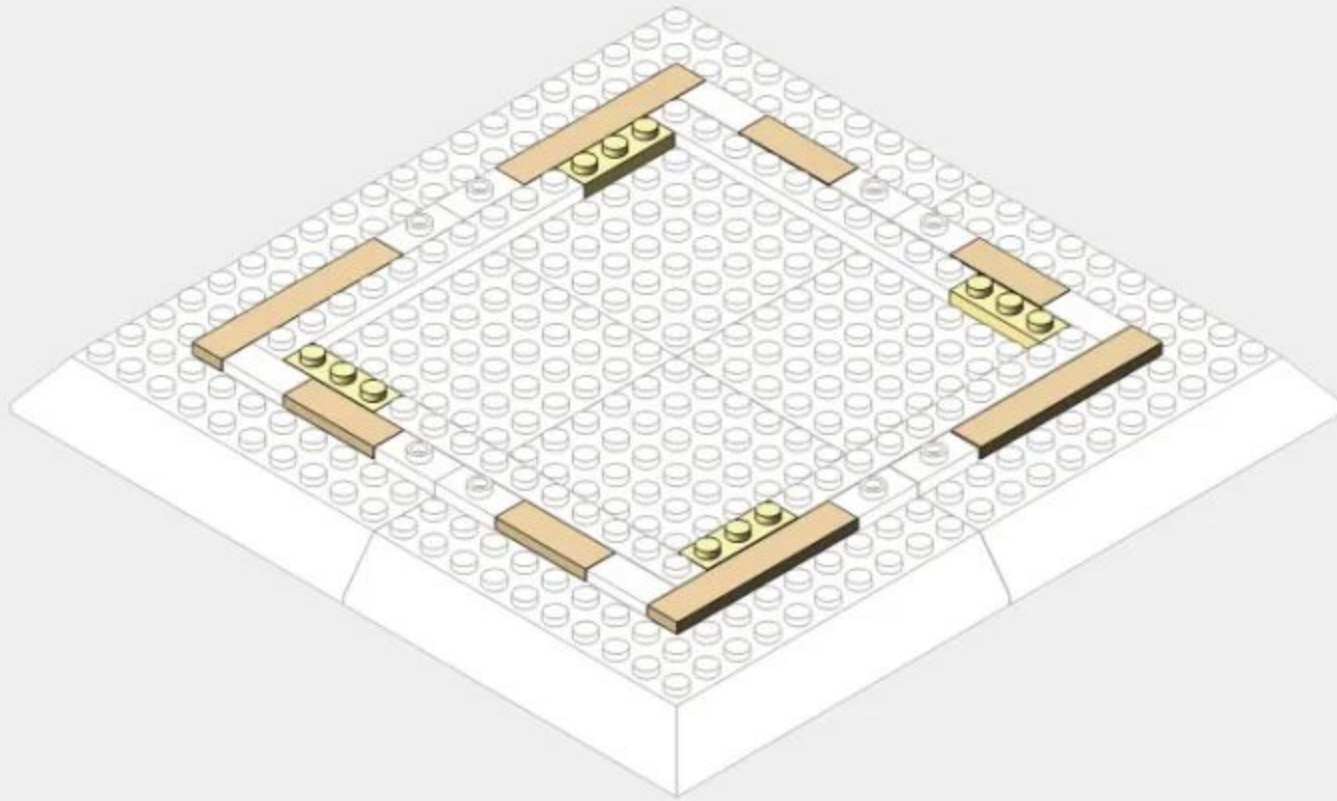
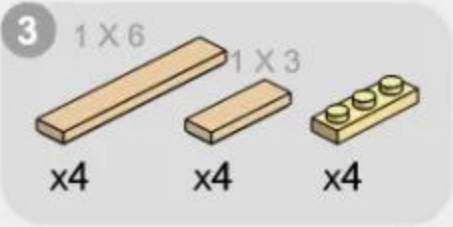

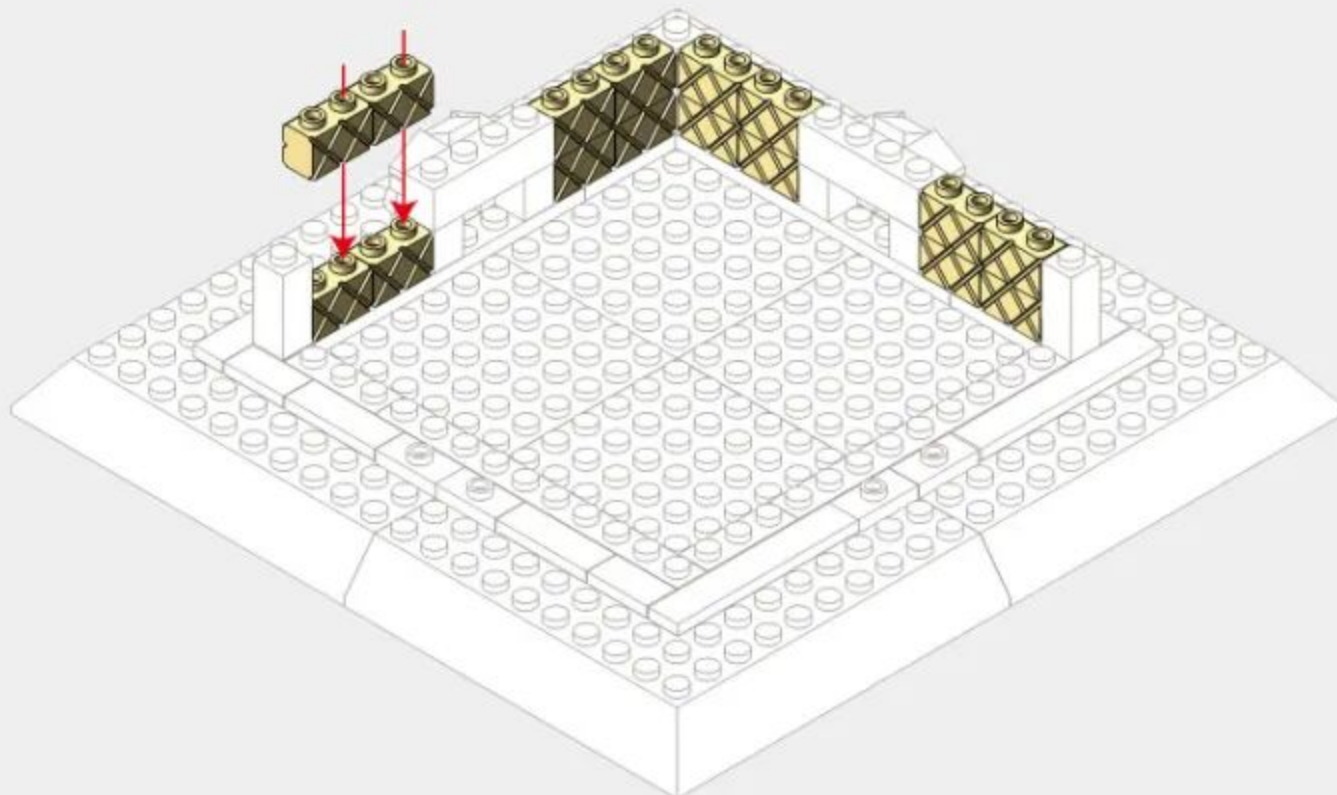
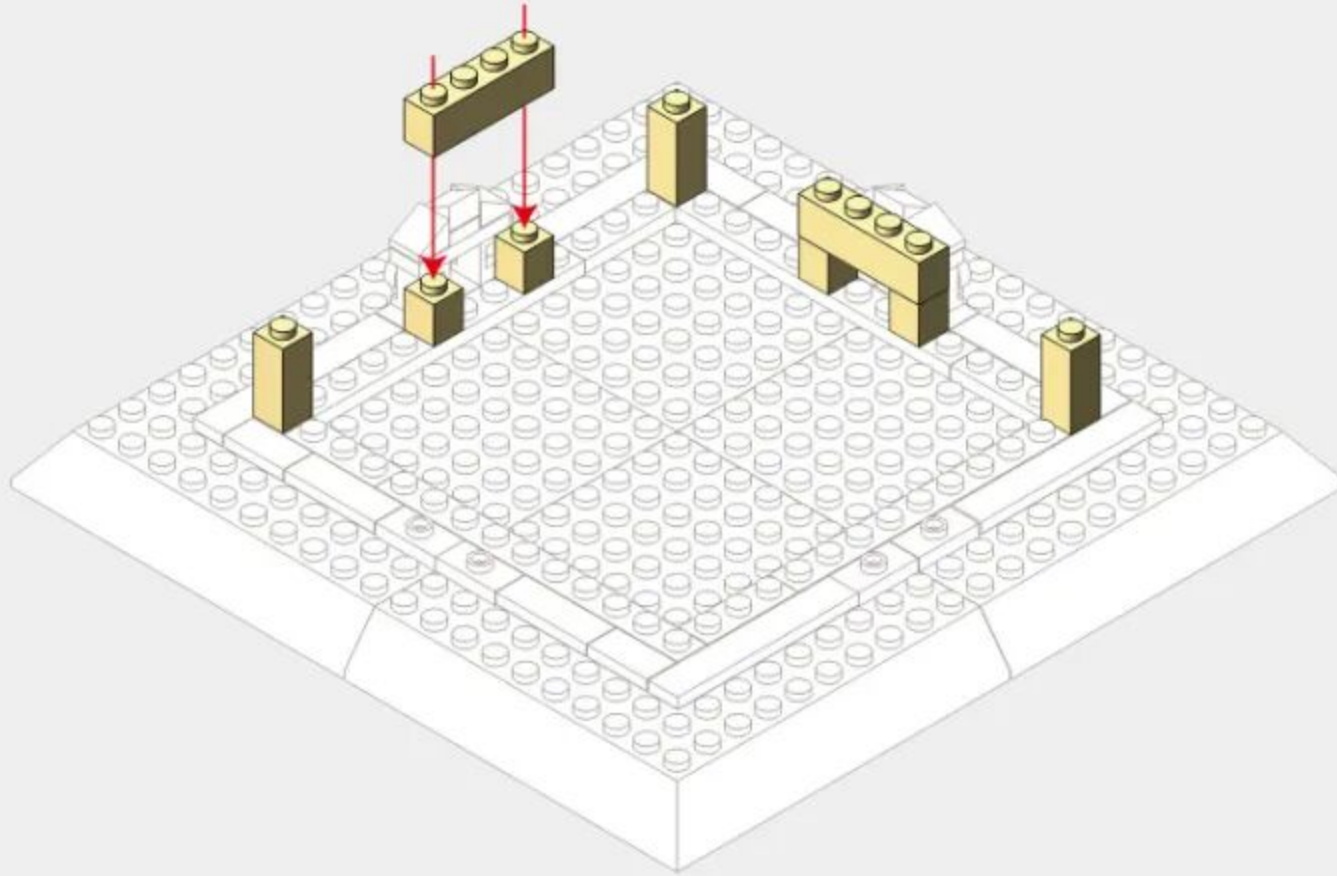
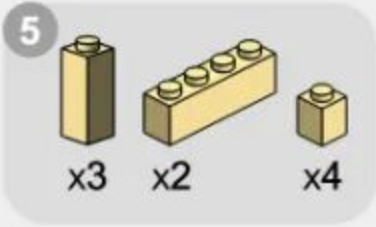

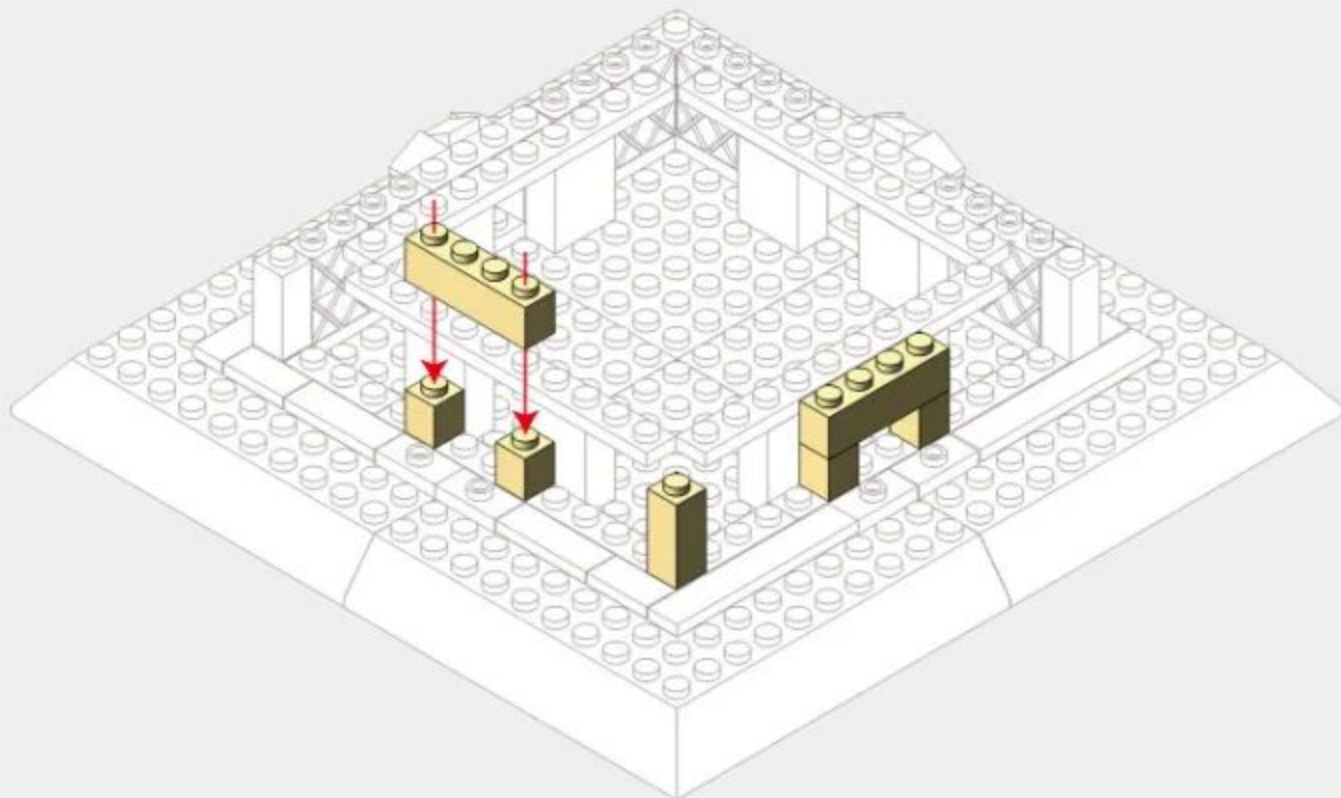
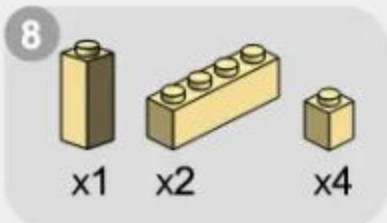
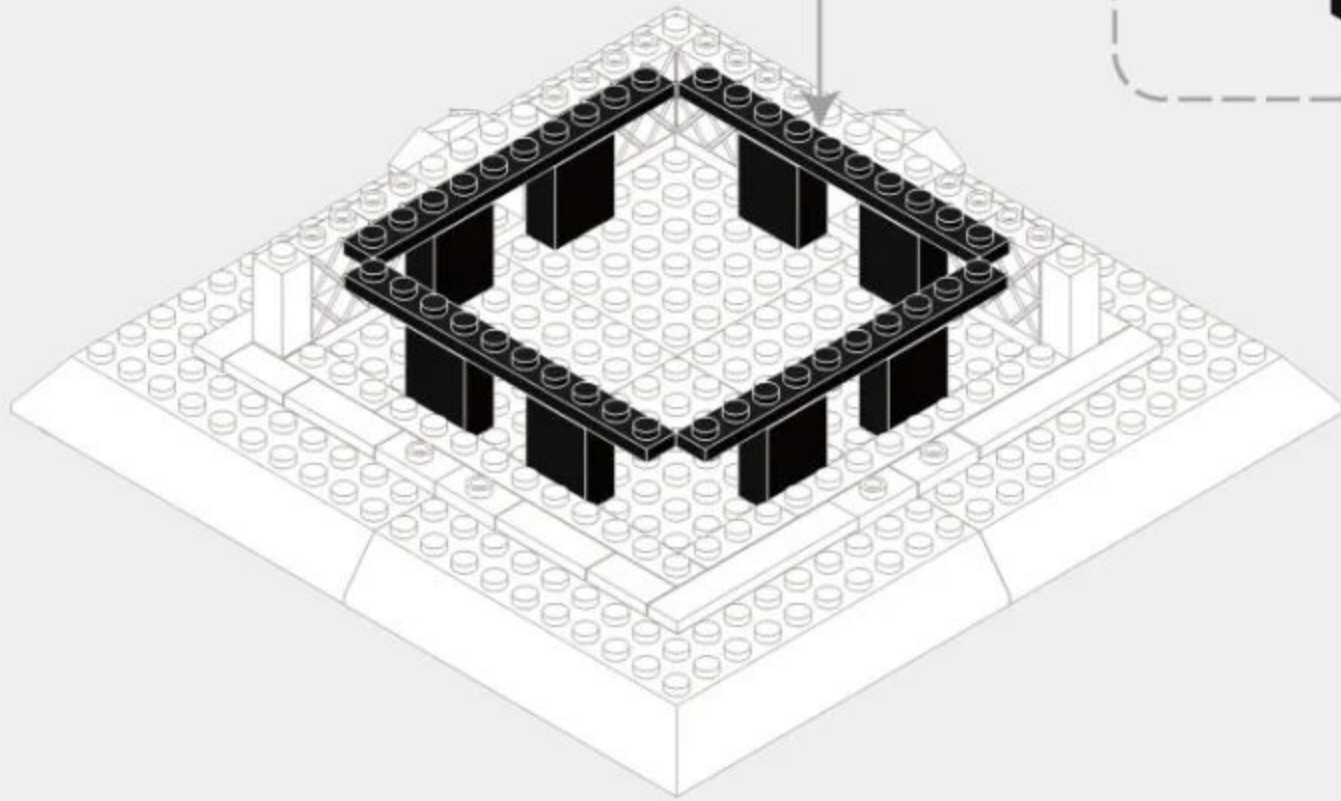
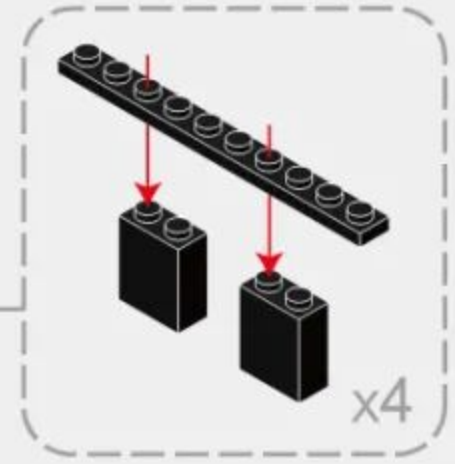
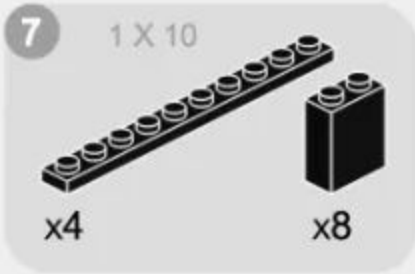

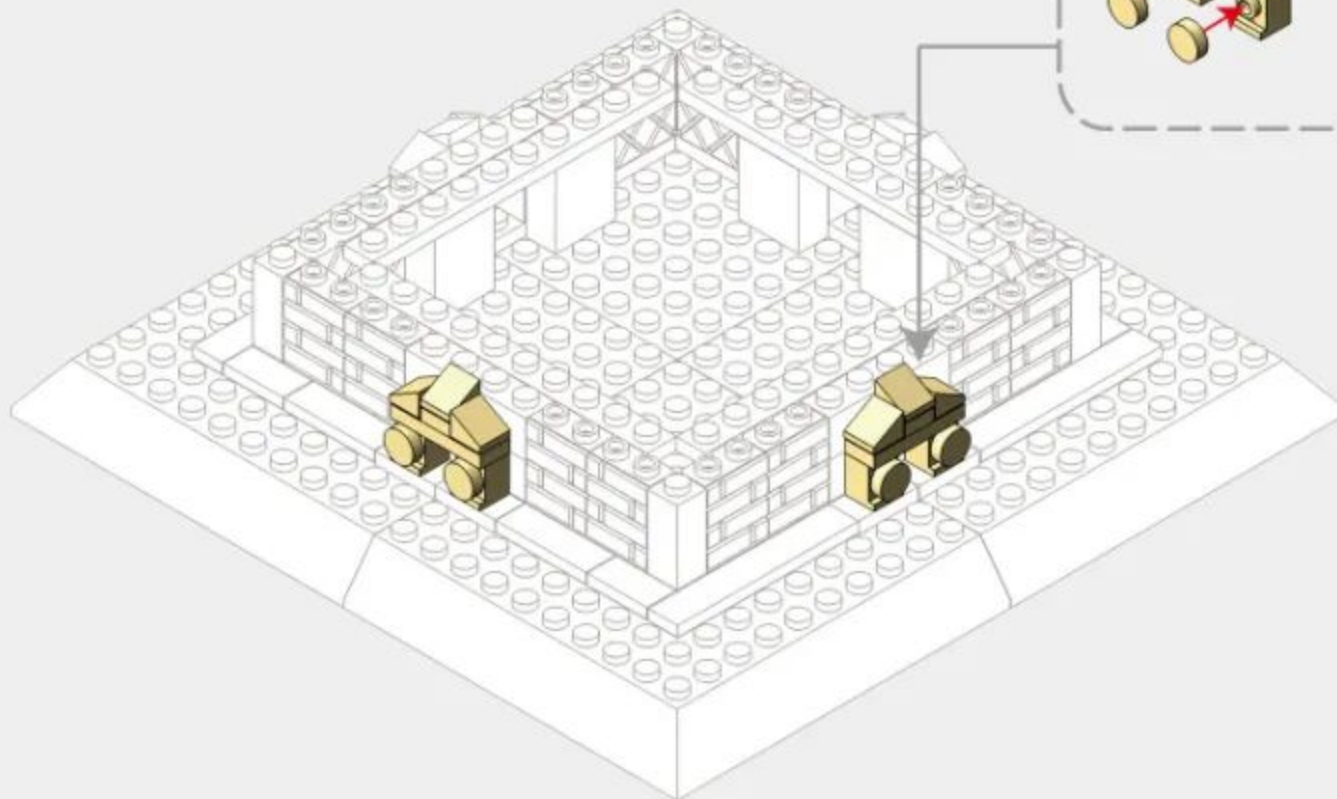
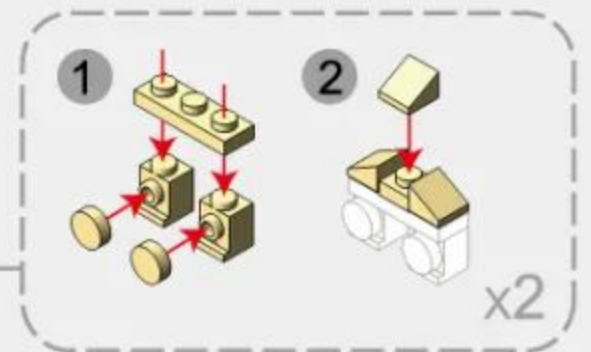
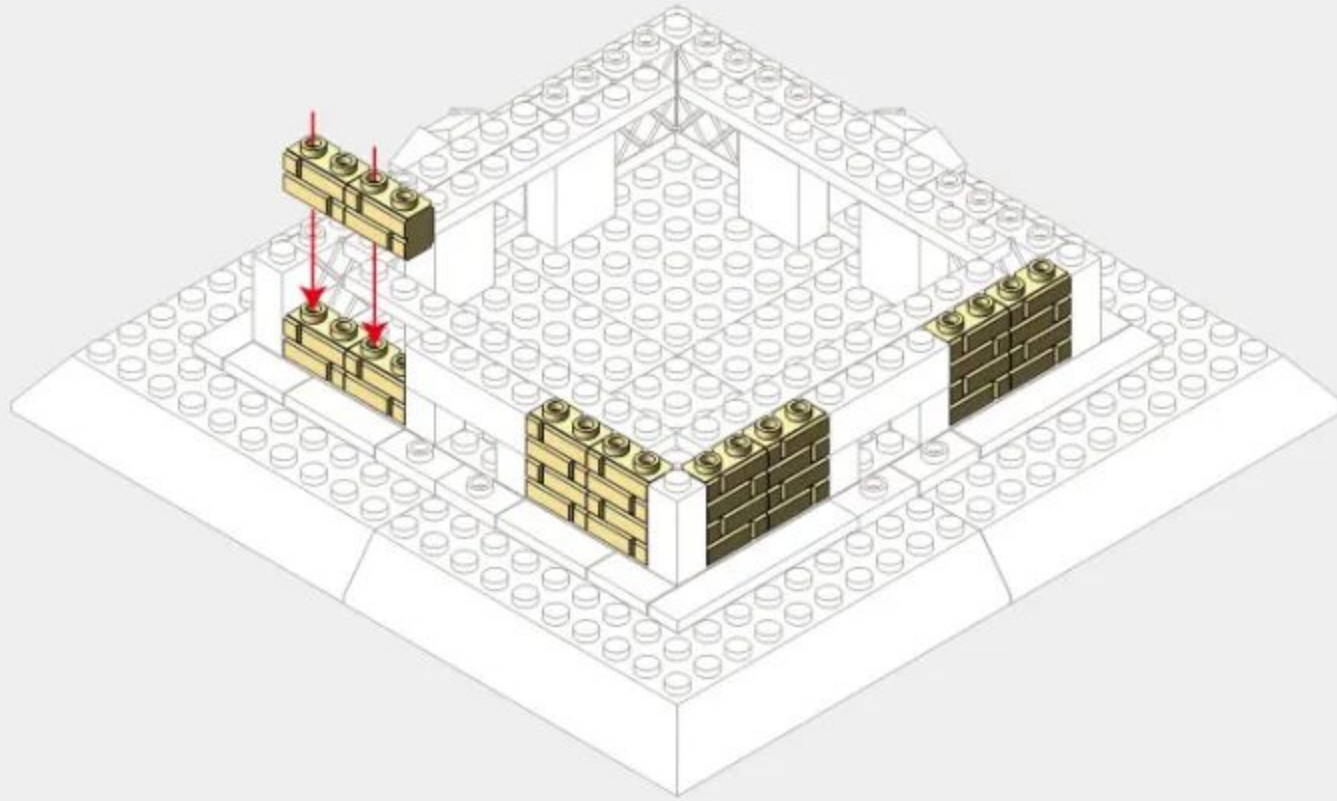

11



x4

x12

x4

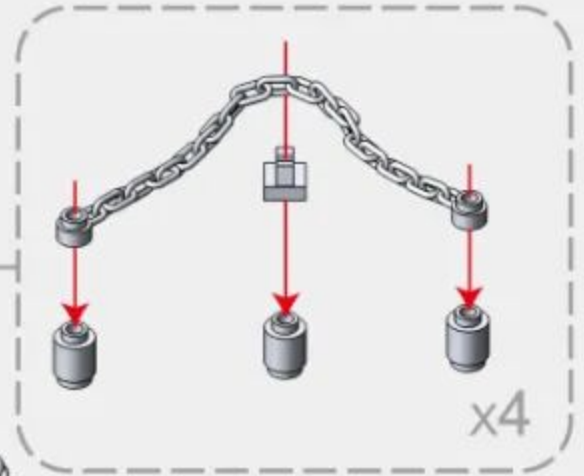
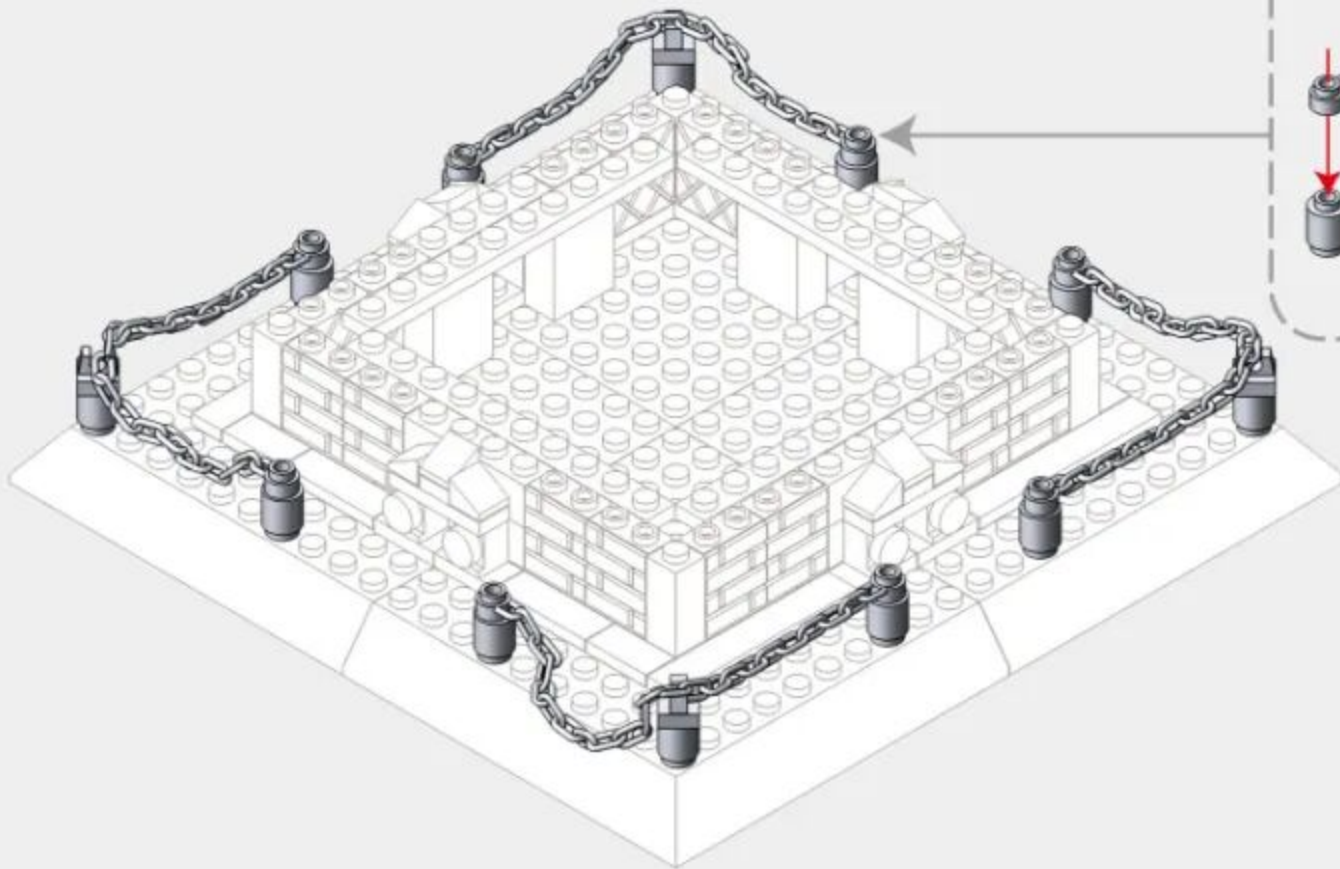

12



x8

x4

x4

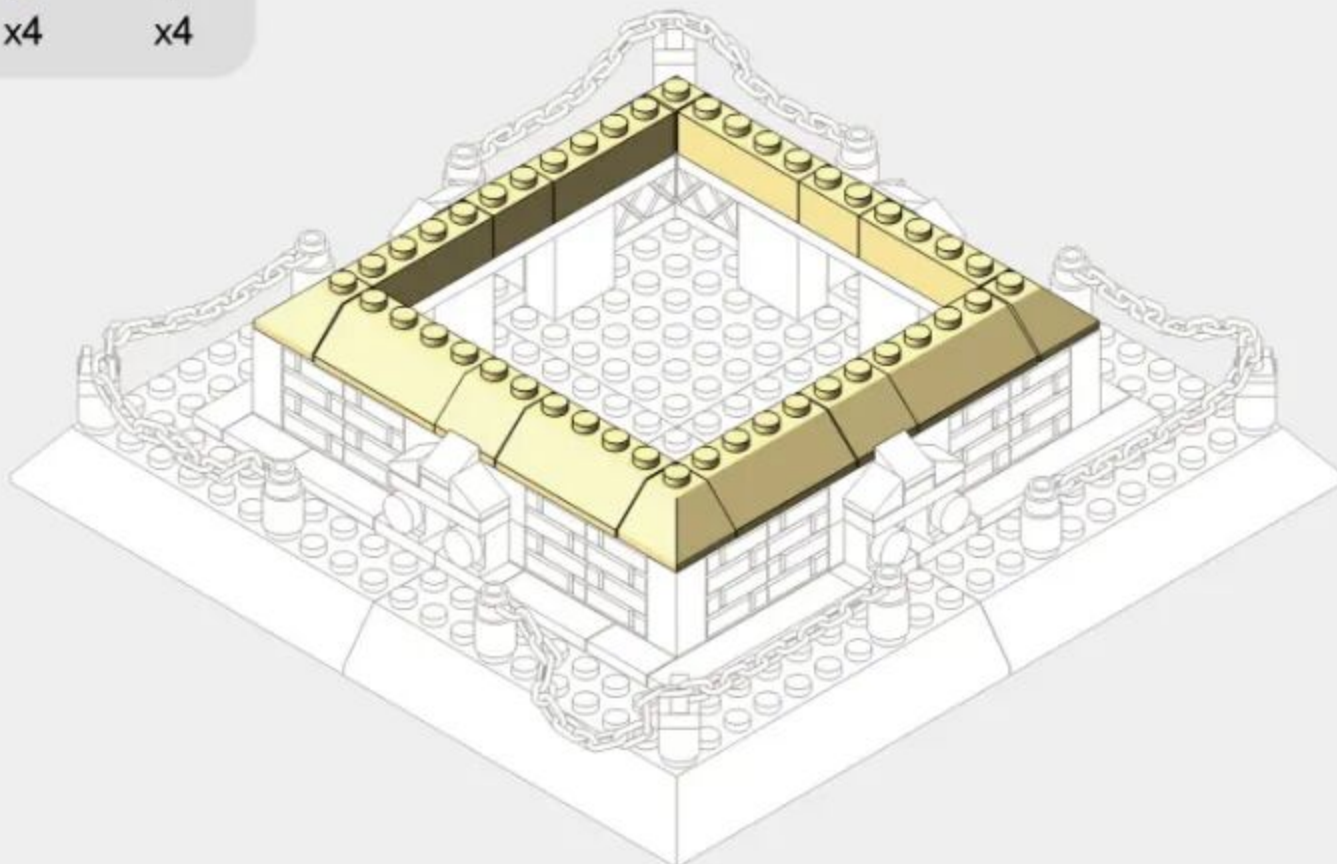

13 2 X 10

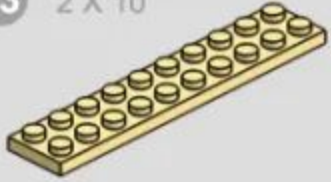

x8

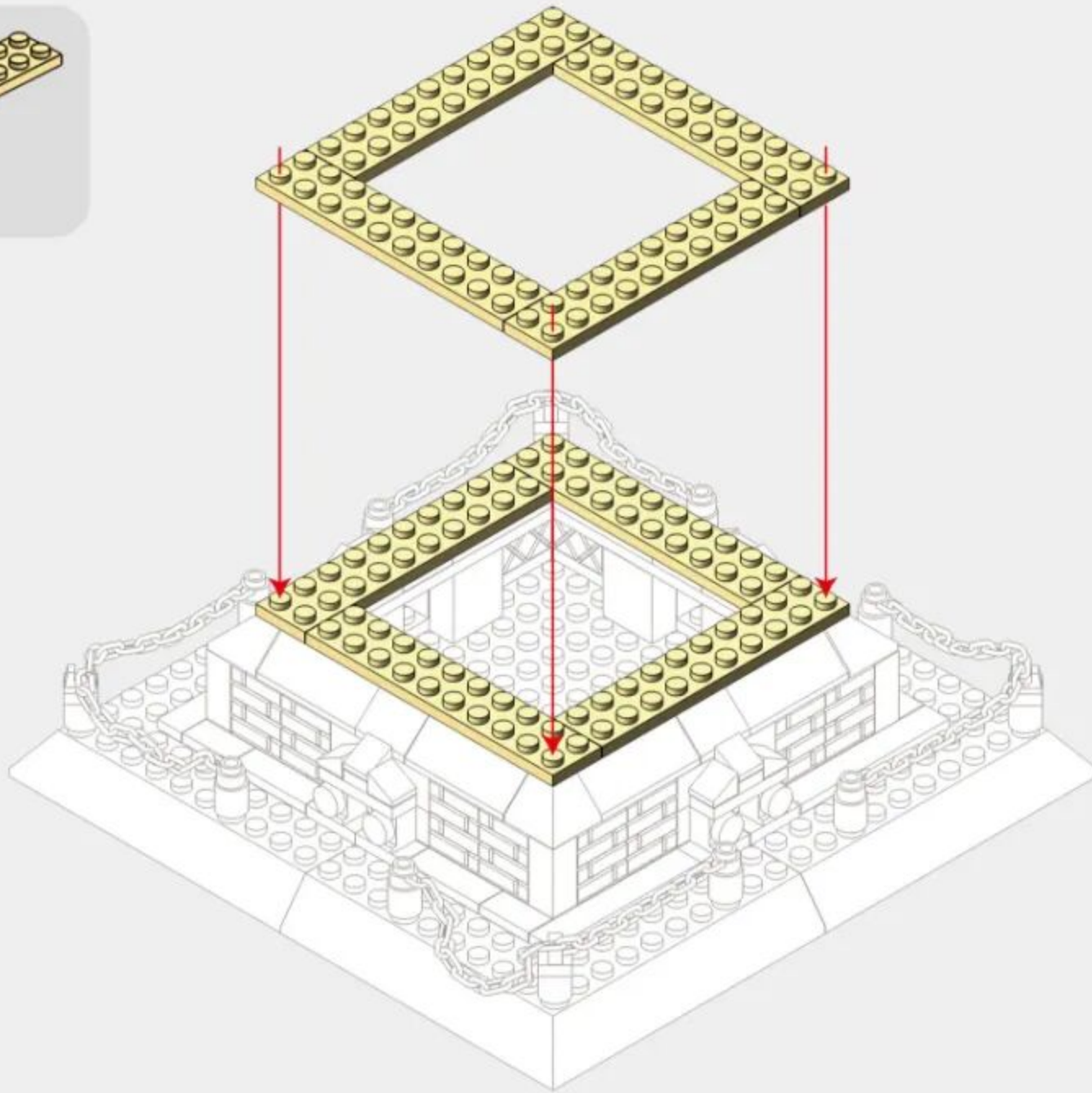

14 1 X 8

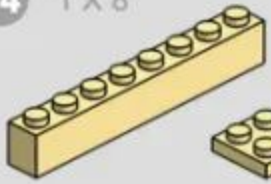

x2



x6



x3



x16

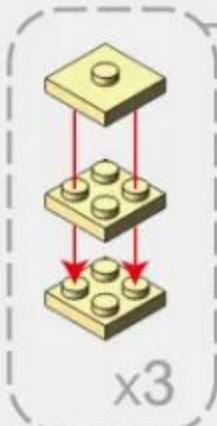
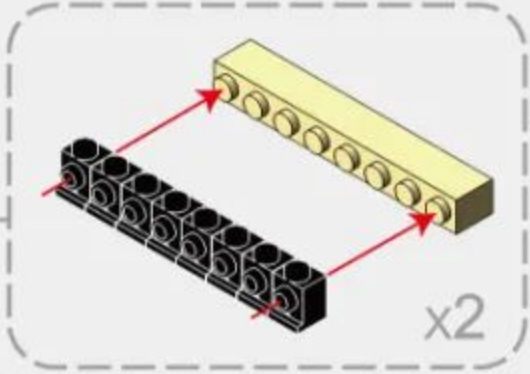
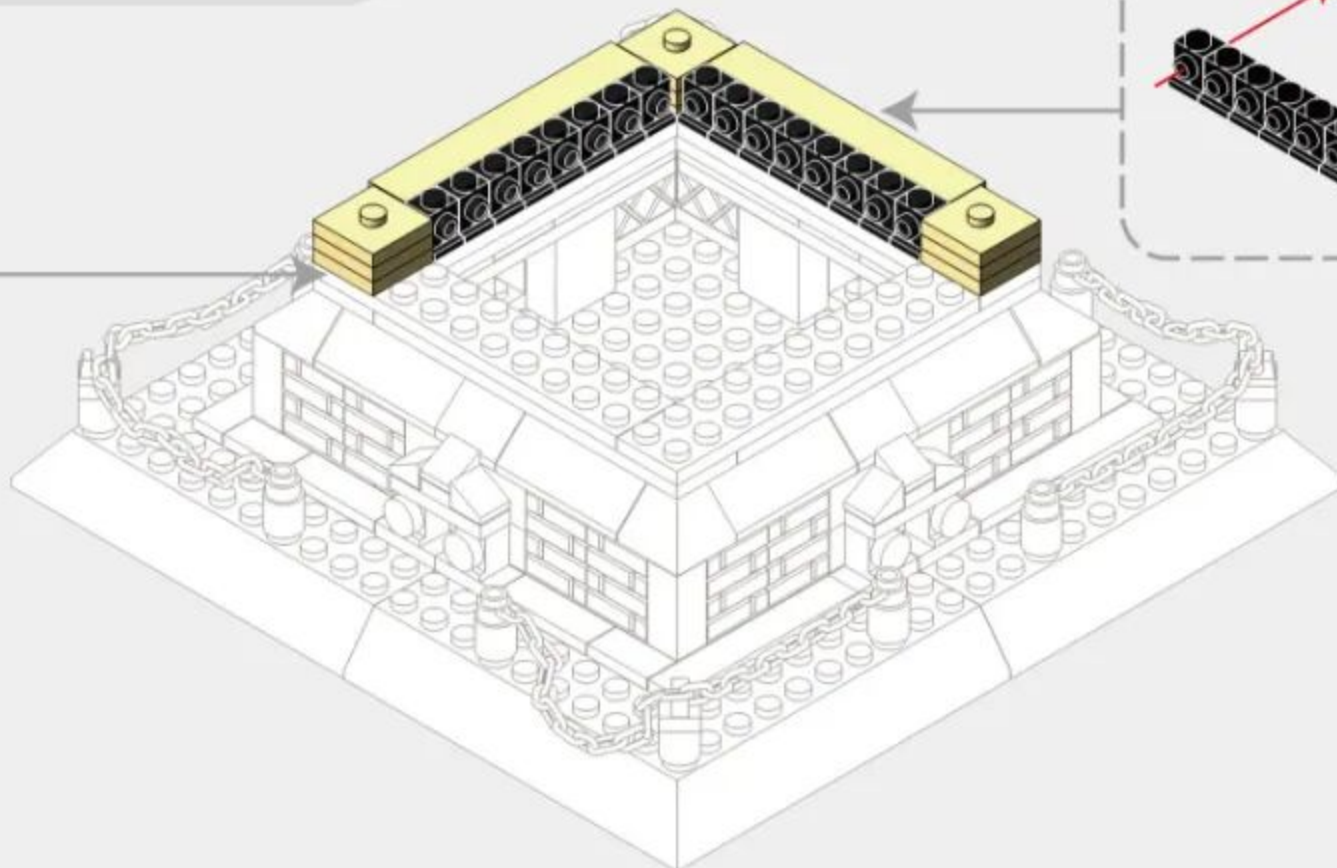

15 1 X 8

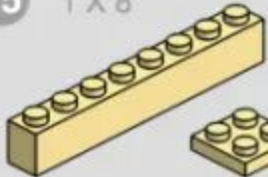

x2



x2



x1



x16

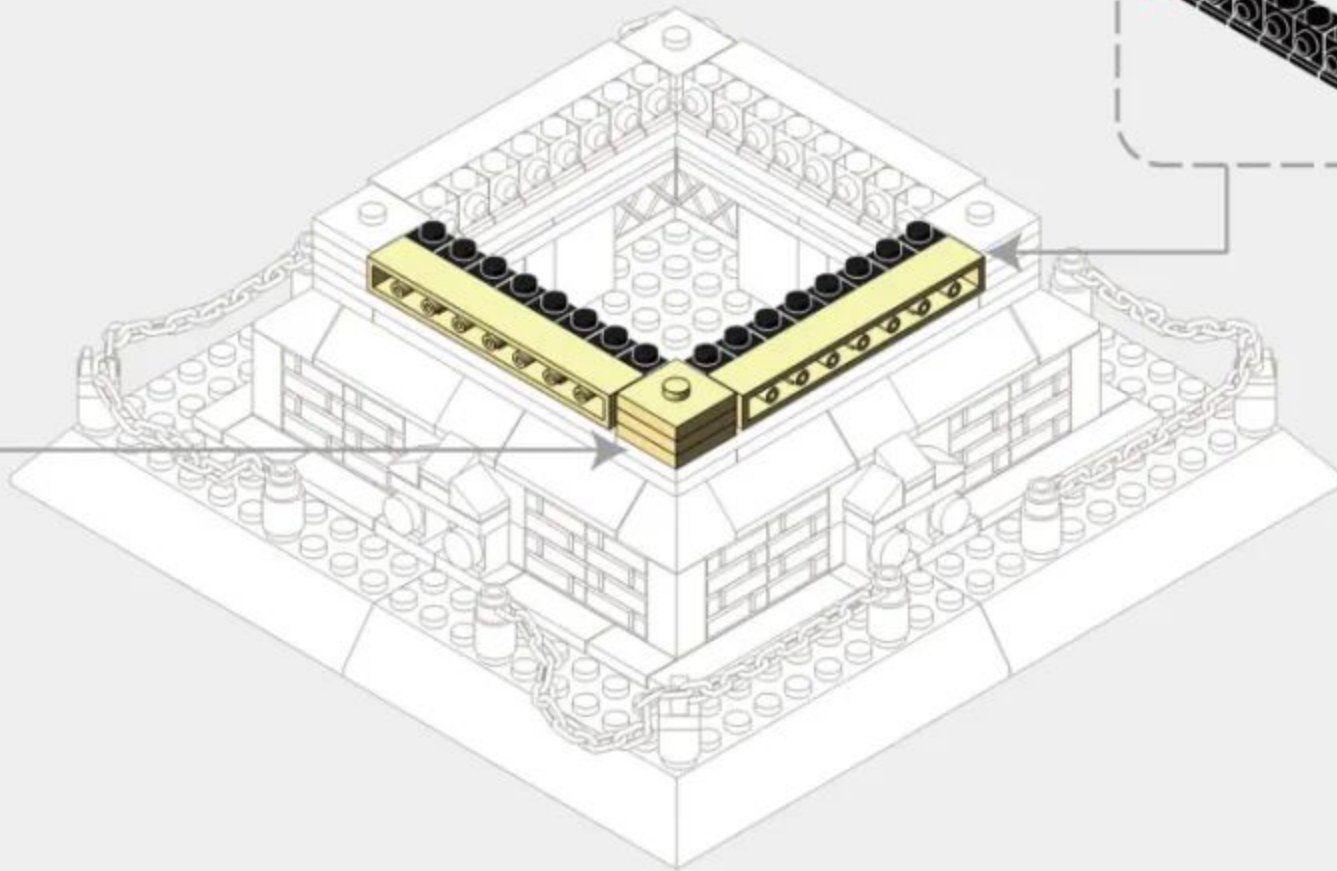
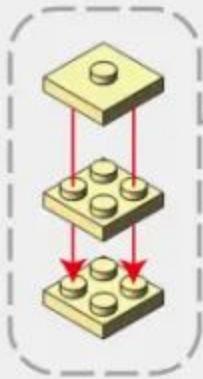
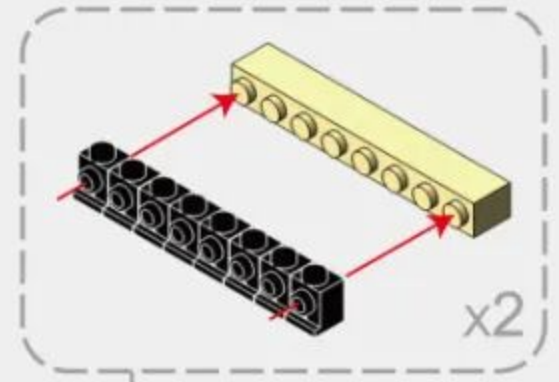

16 2 X 12

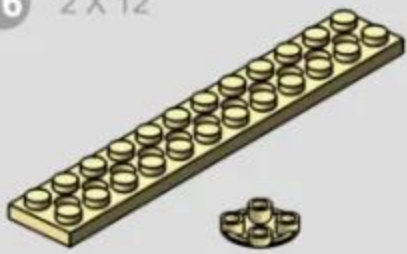

x4





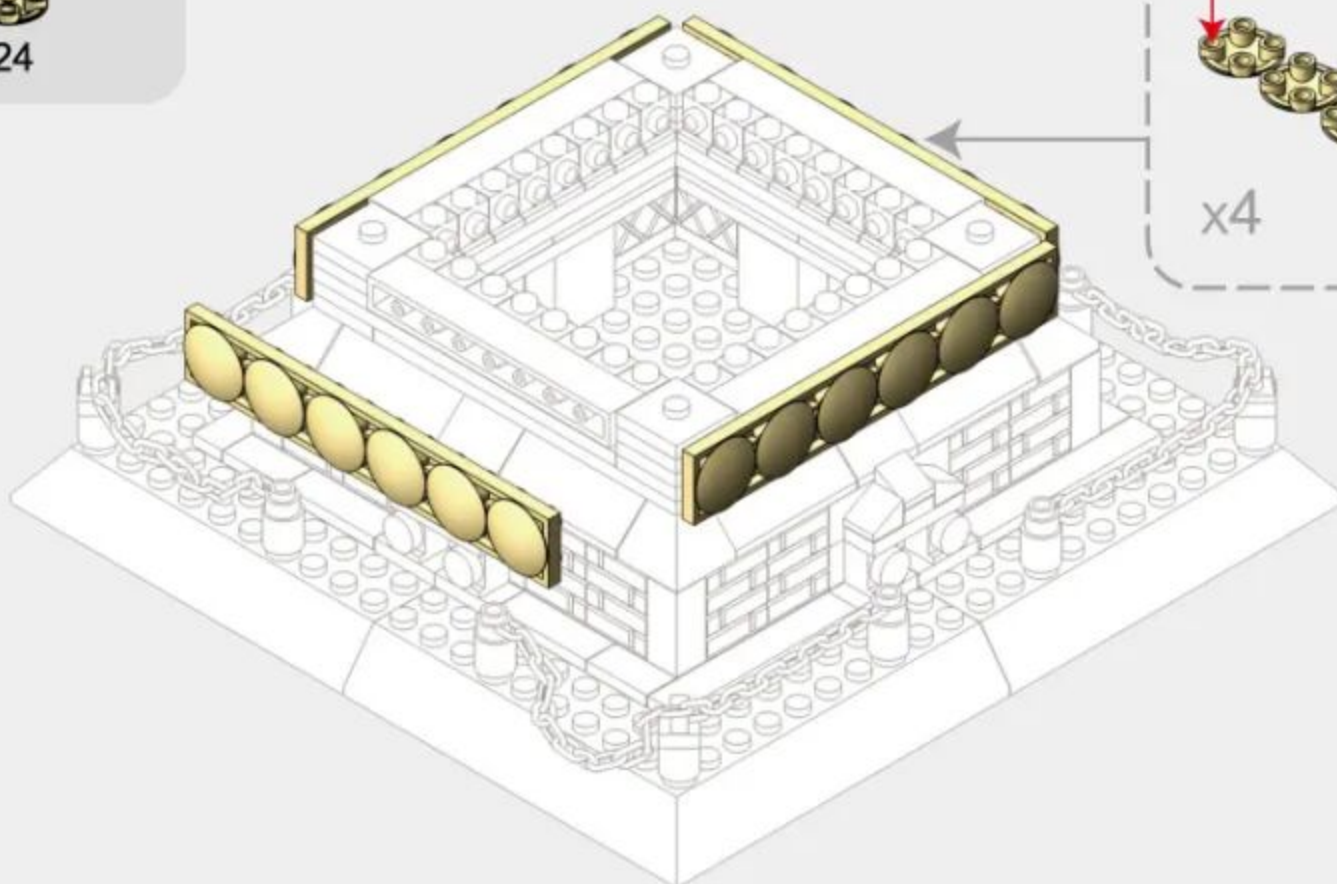
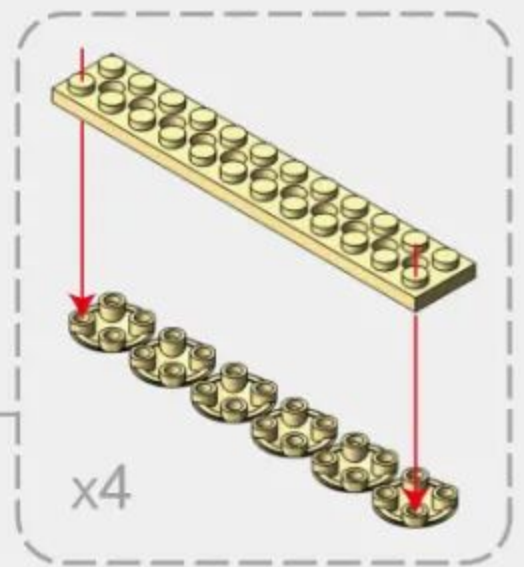



x24

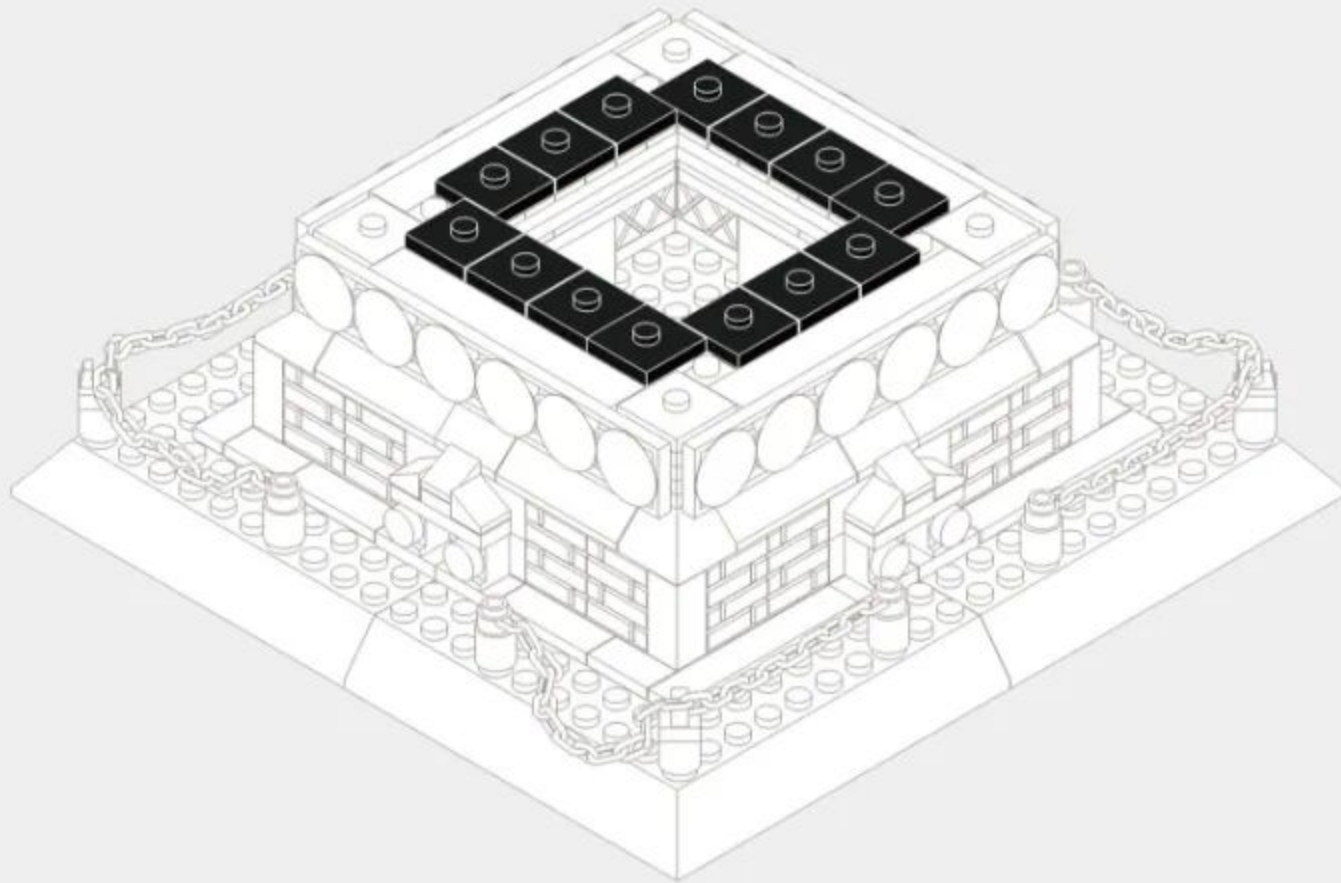

17

x14



18
4 X 6 4 X 4 1 X 6
     
x4 x2 x4 x4 x4 x4

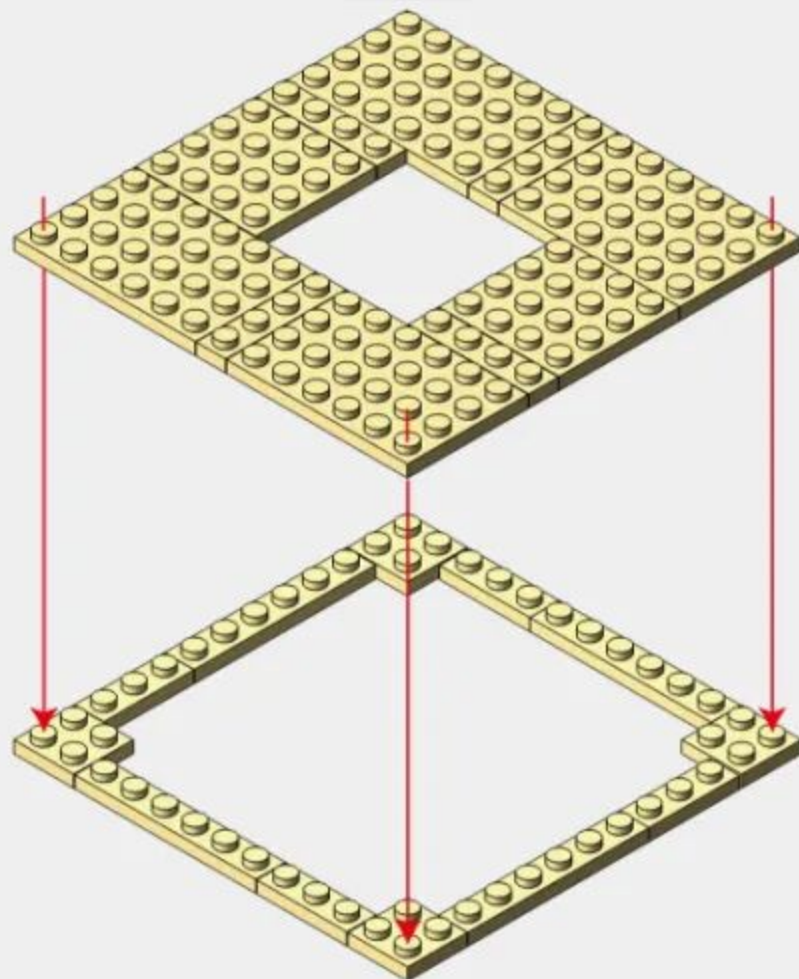

19

17 + 18

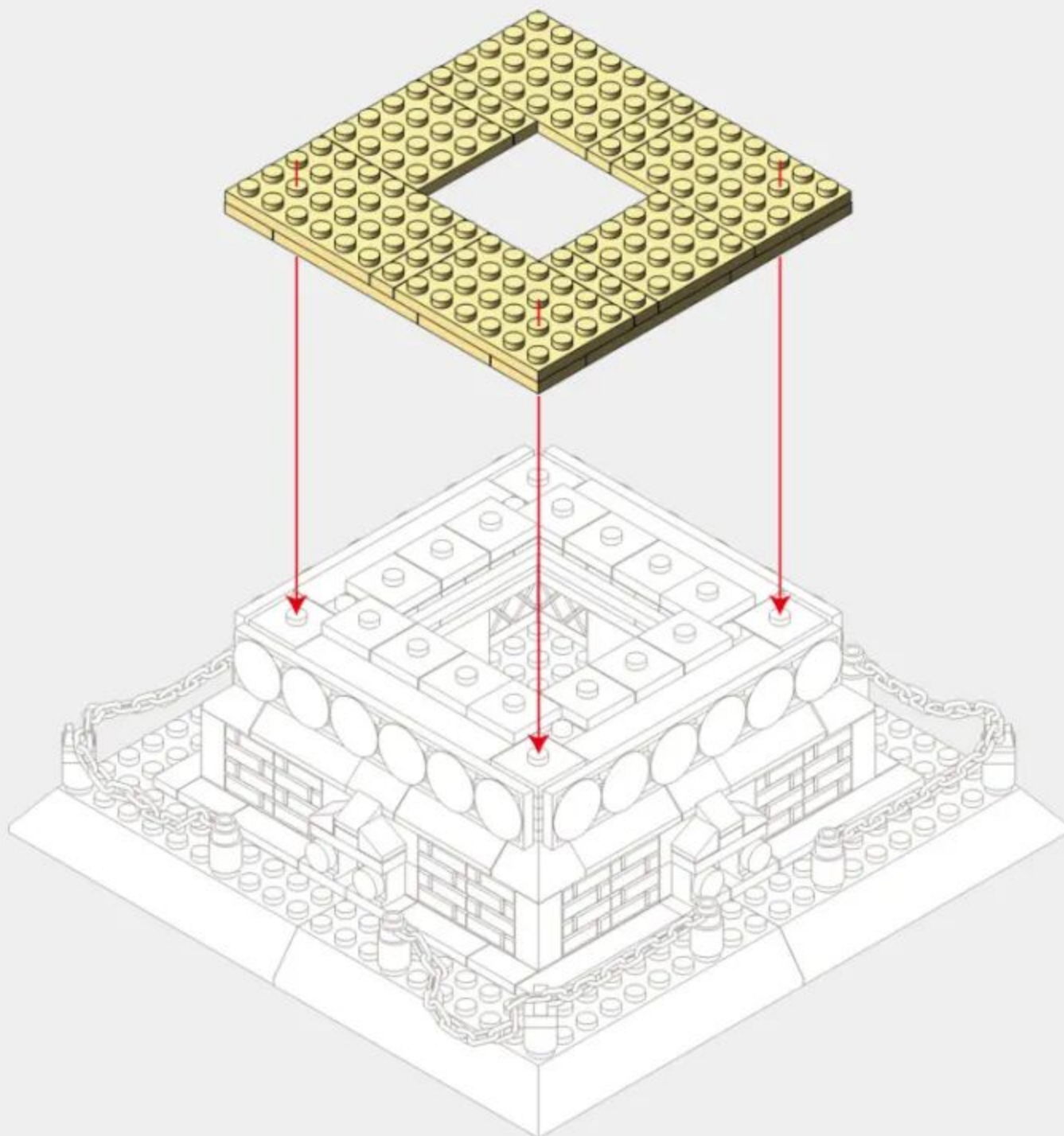

20

x20 x16

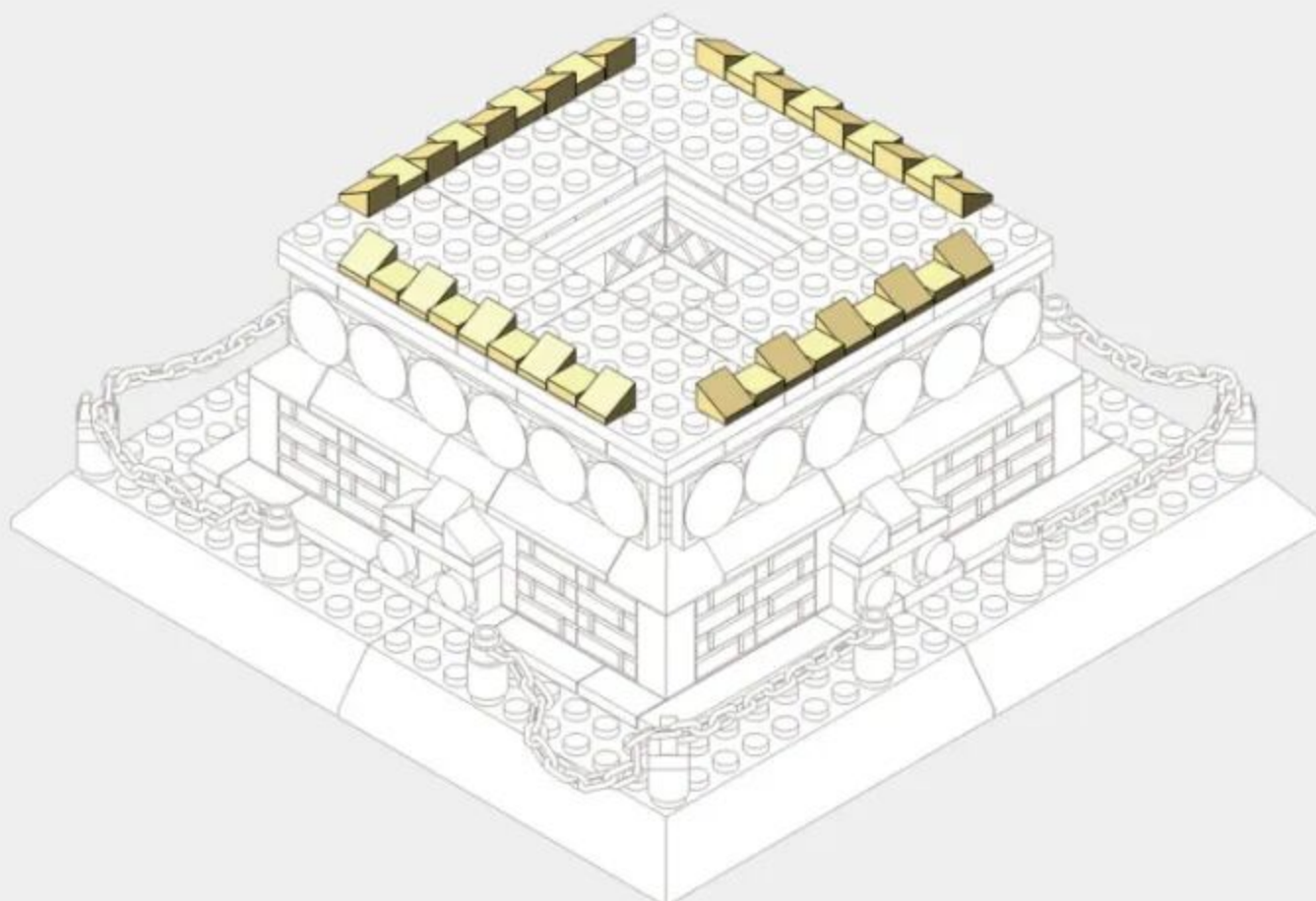

21 1 X 6
 x2 x2 x3

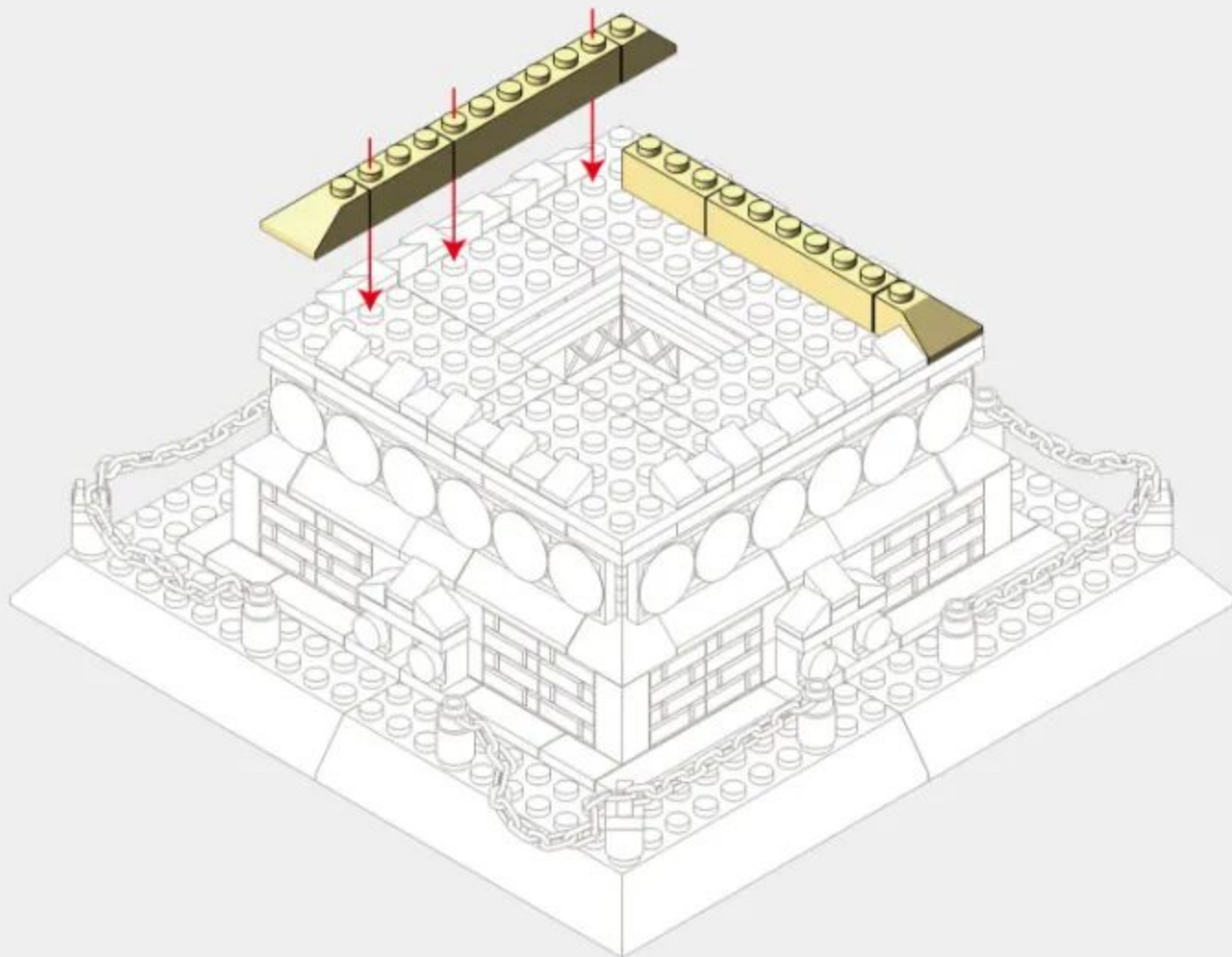

22
 x4 x8

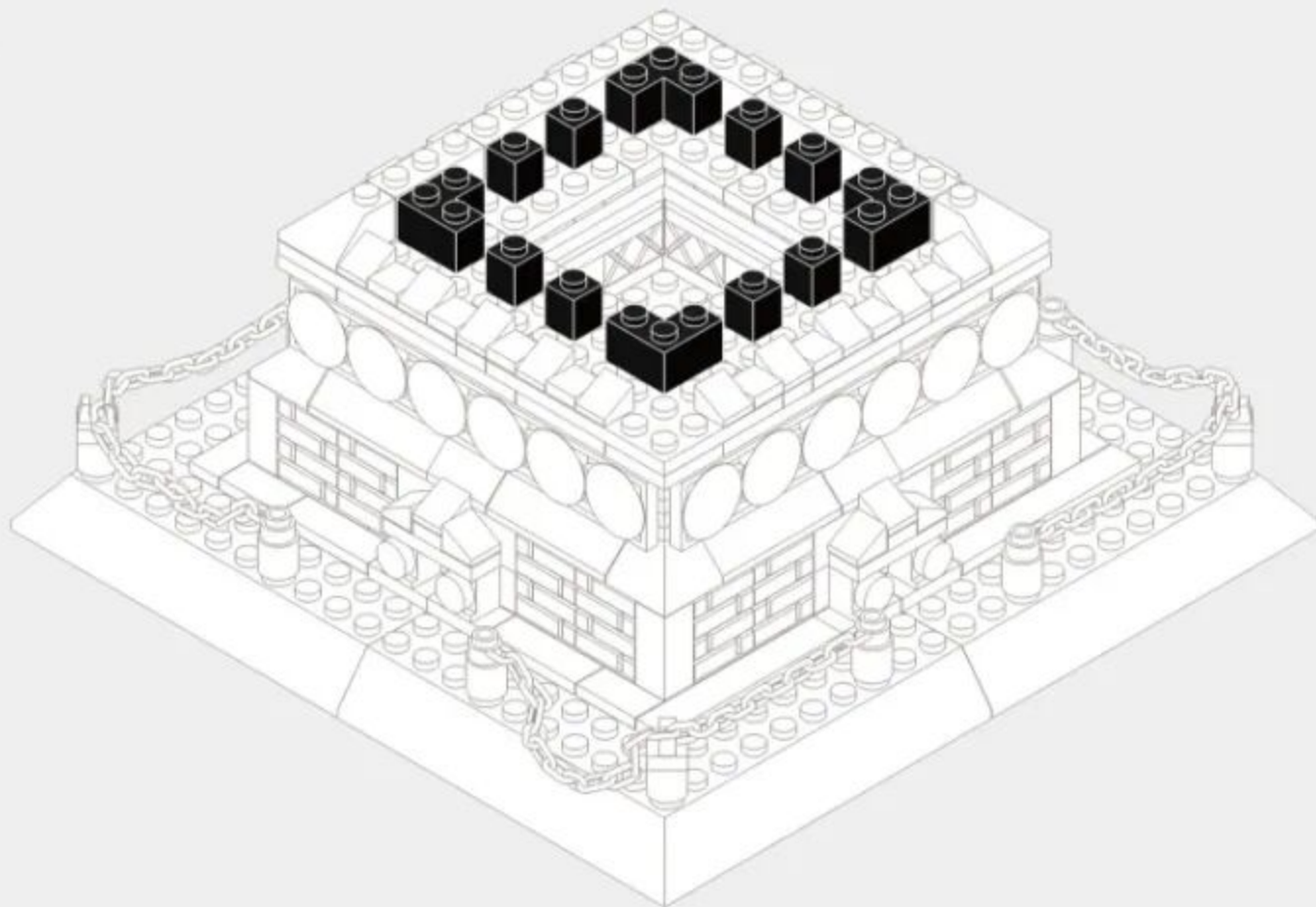

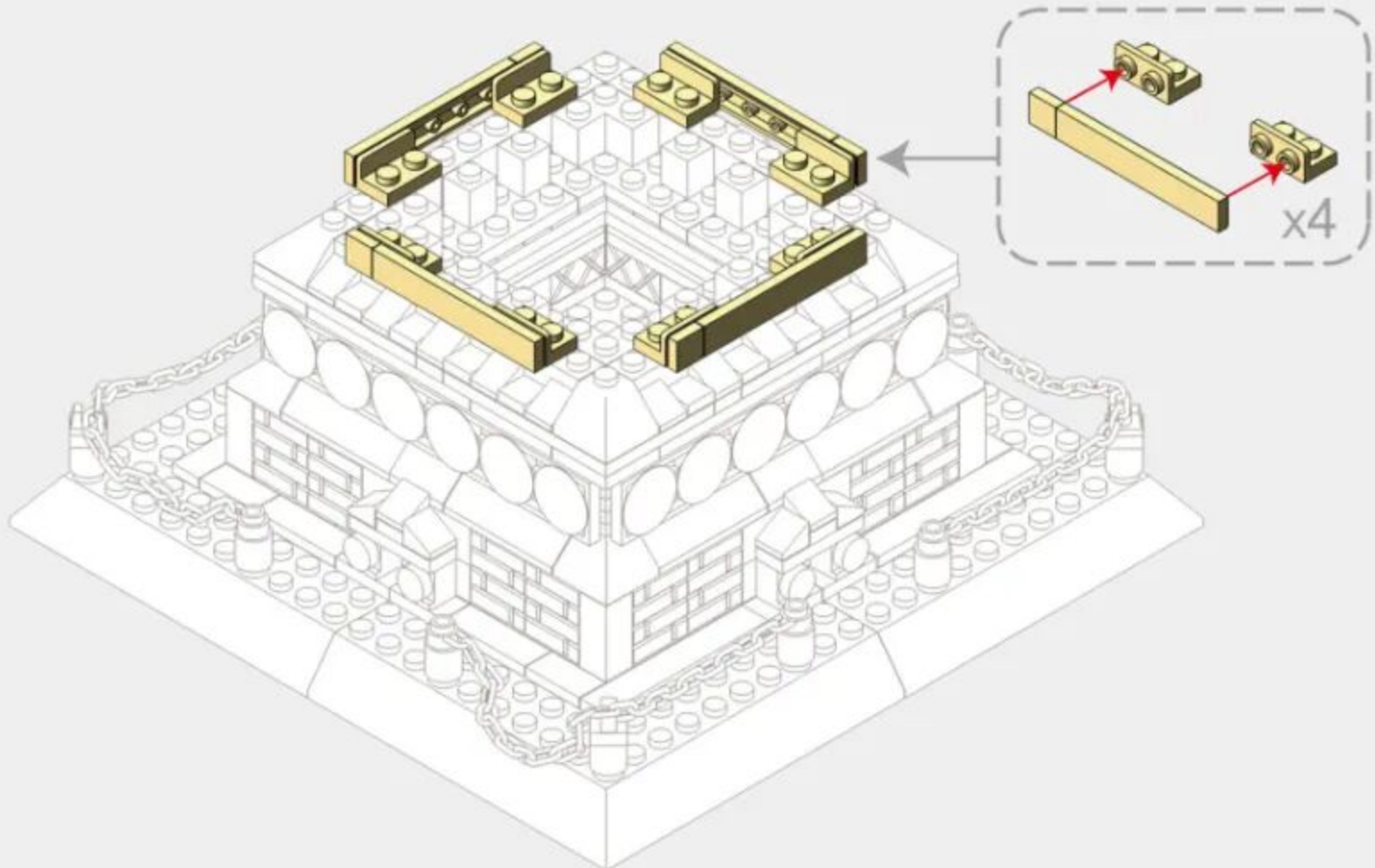
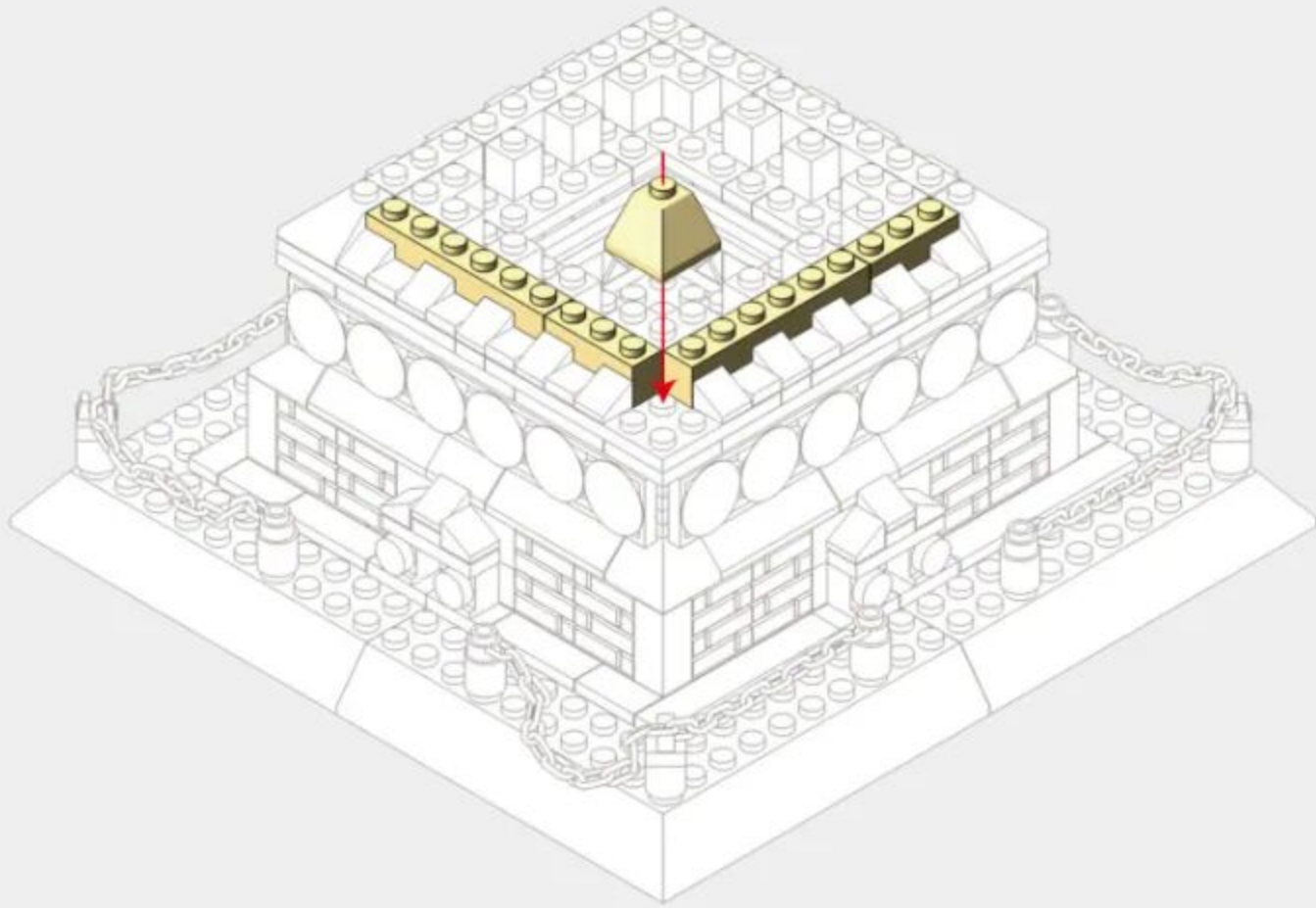
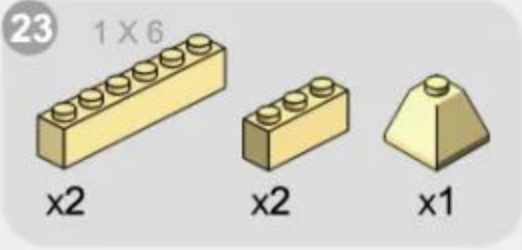

25



x4



x8

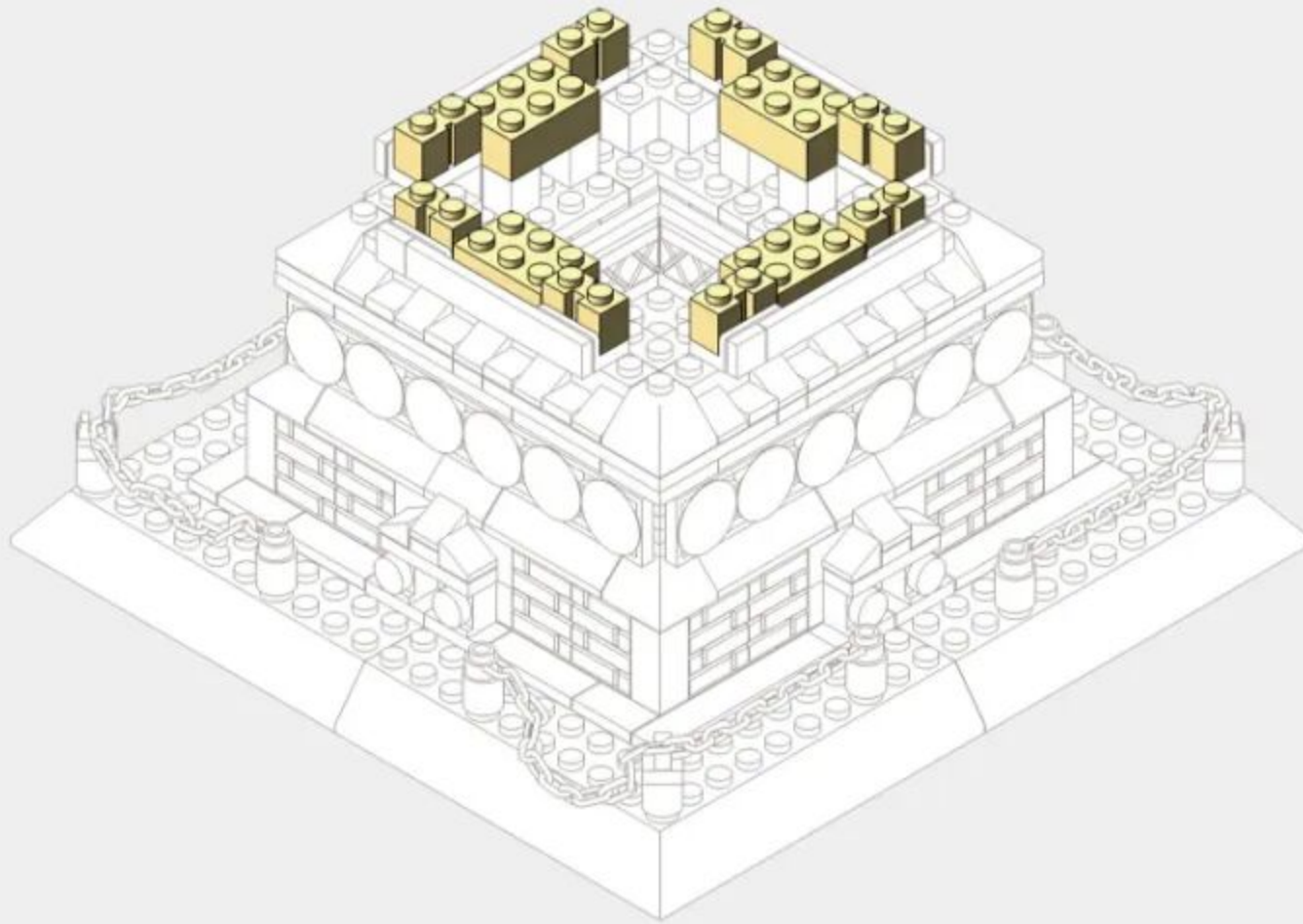

26



x12



x8

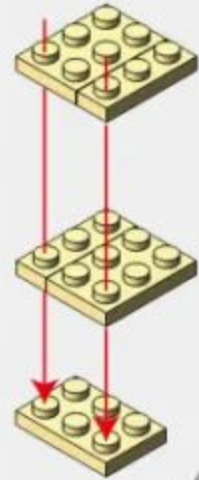
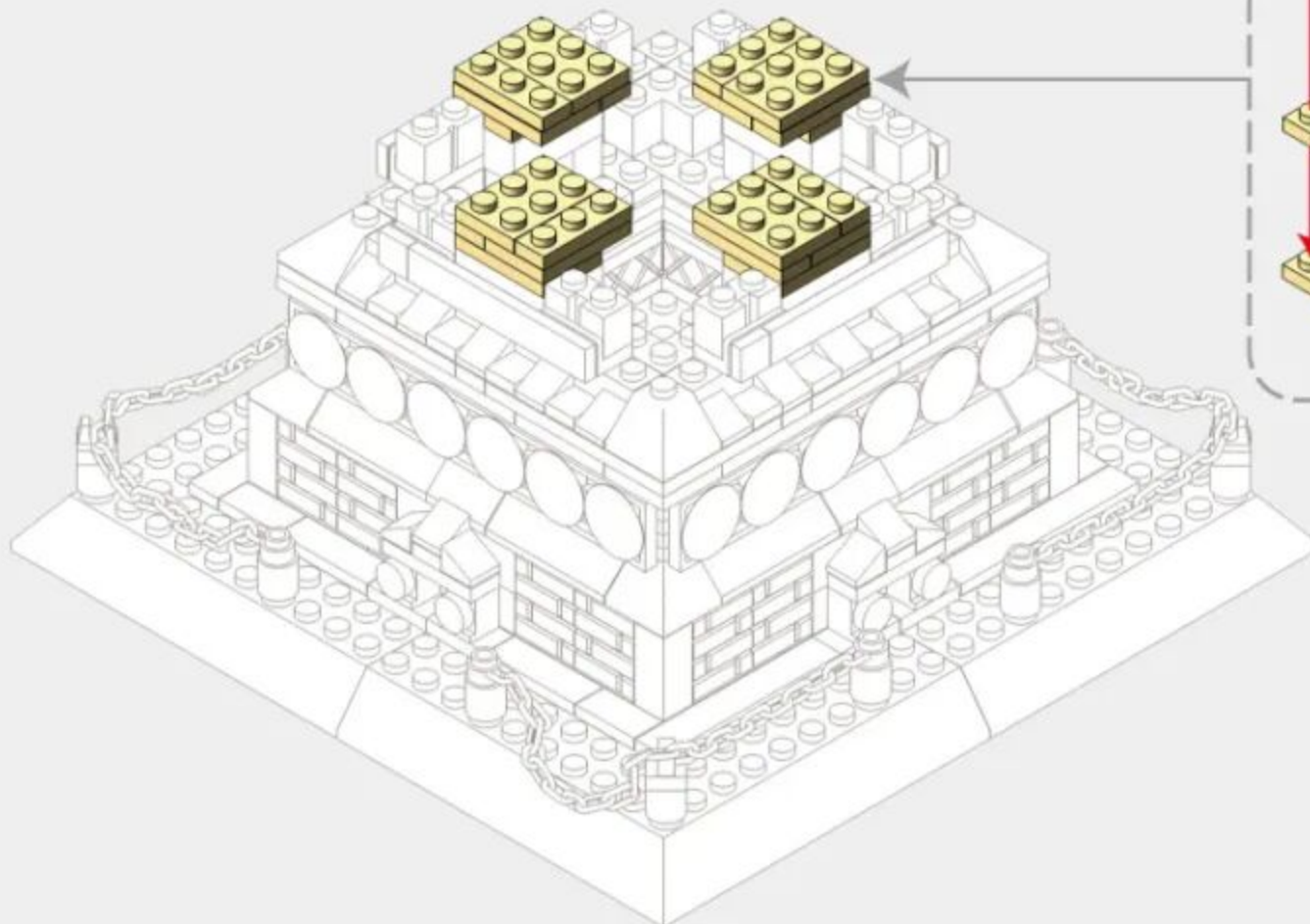

x4

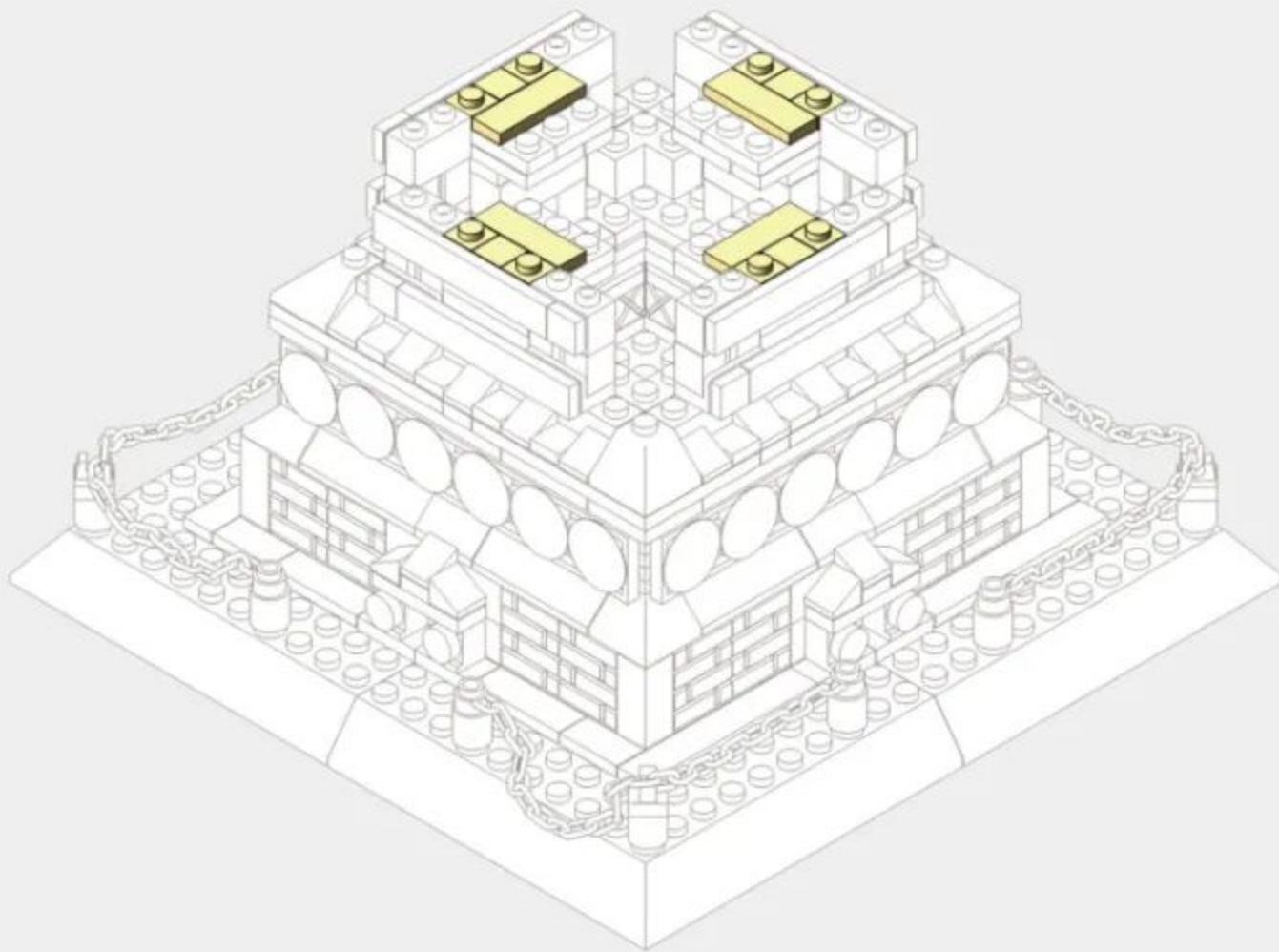
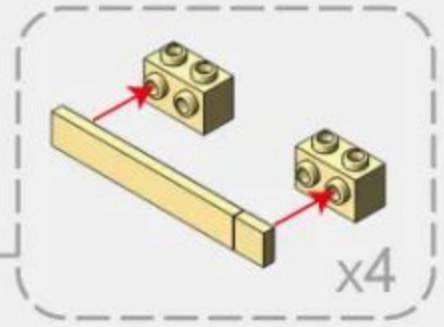
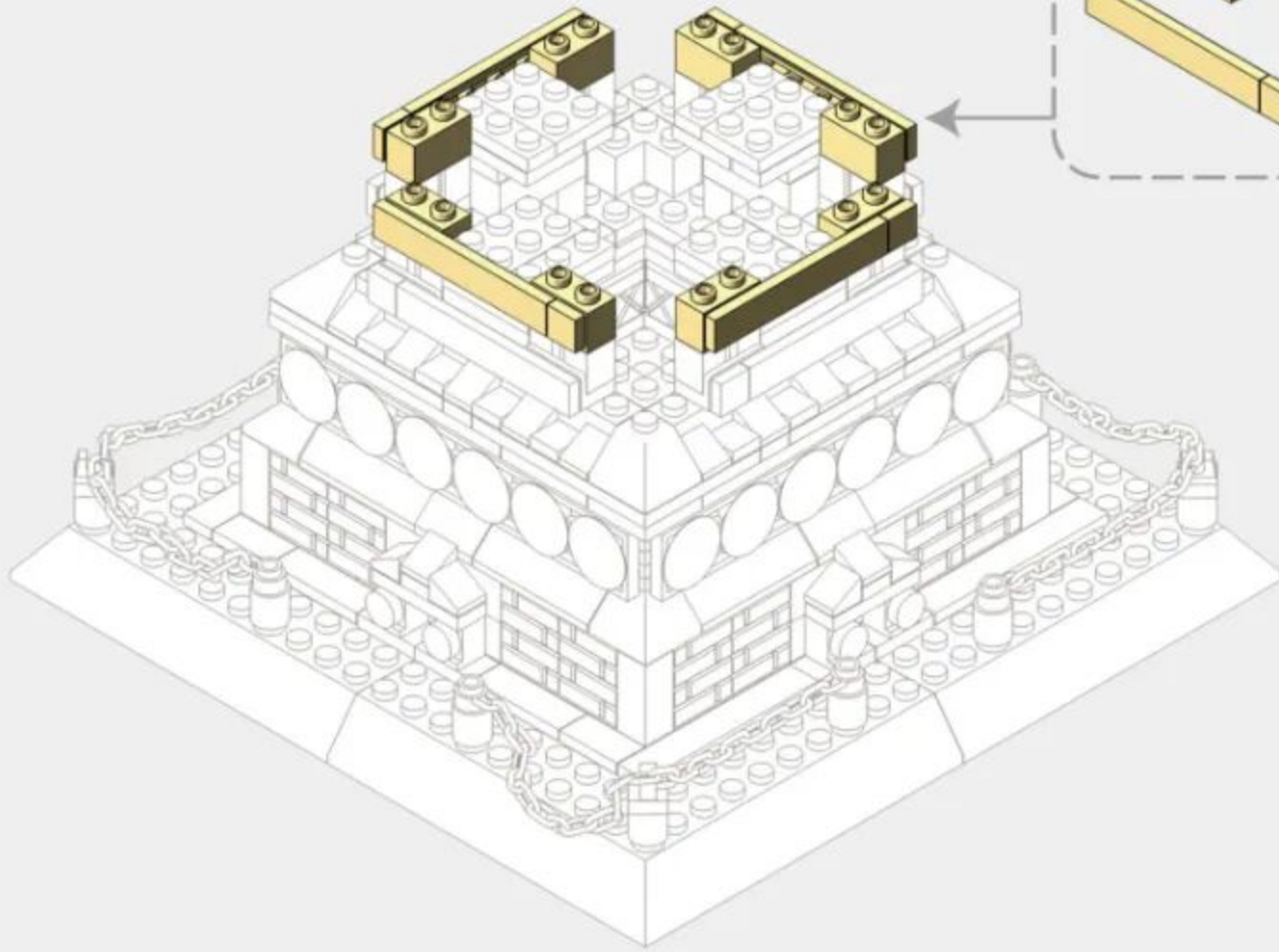
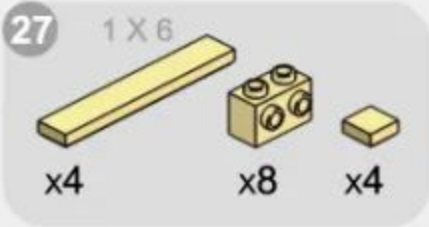

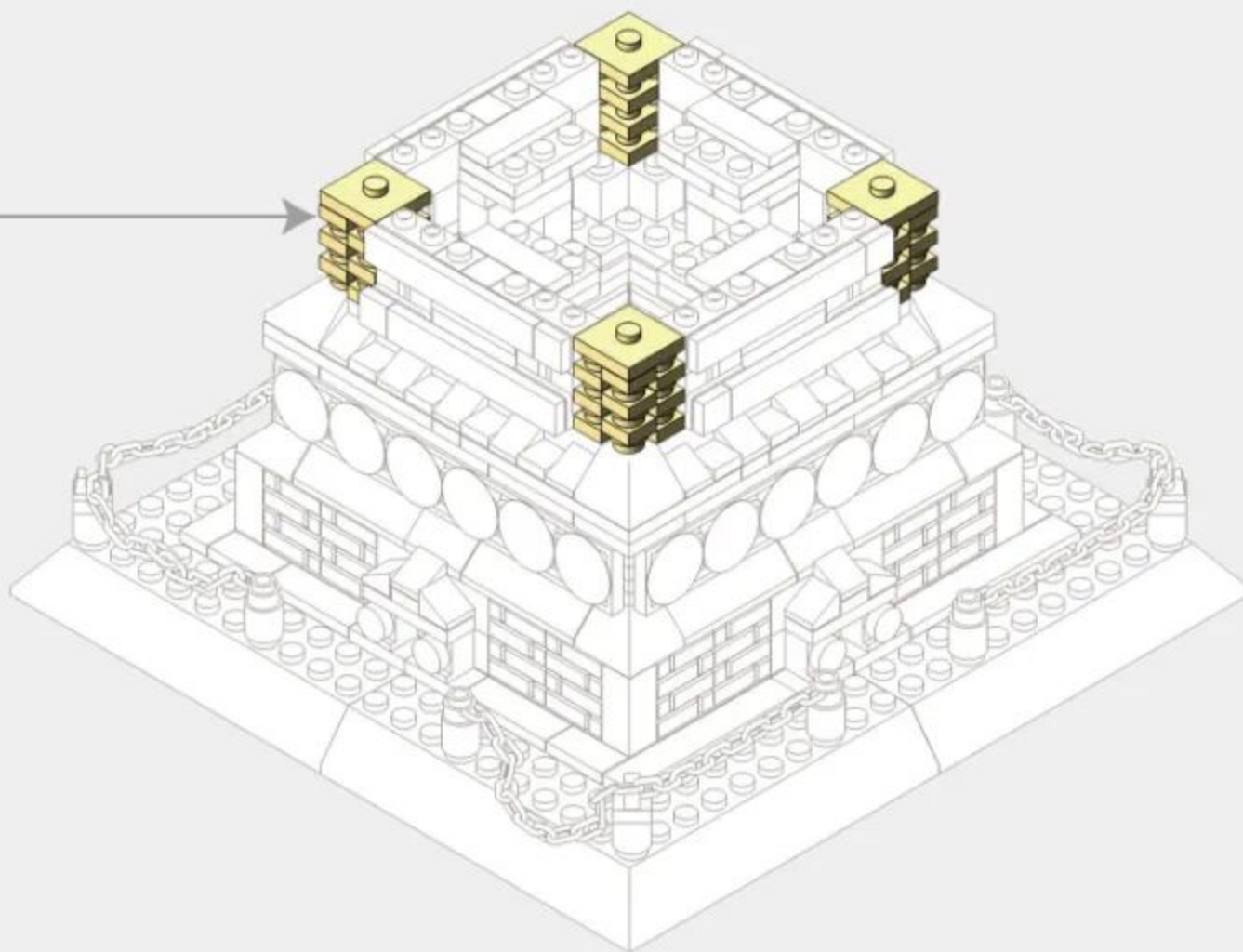
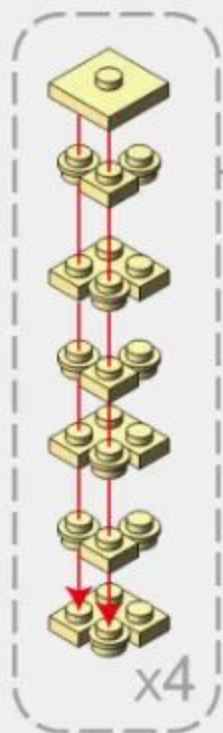

29

-  x4
-  x12
-  x12
-  x36



30

2 X 4

-  x8
-  x4

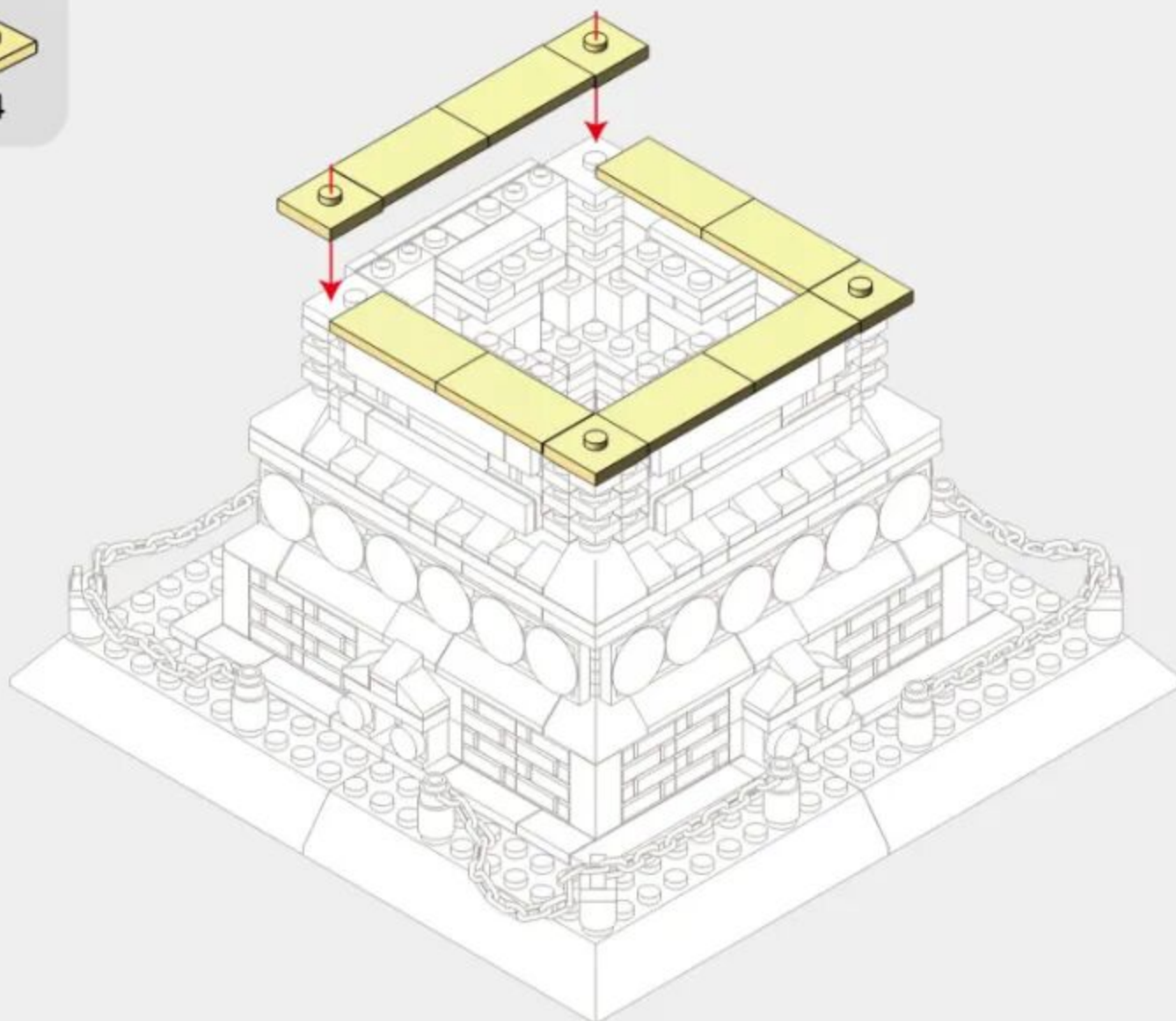

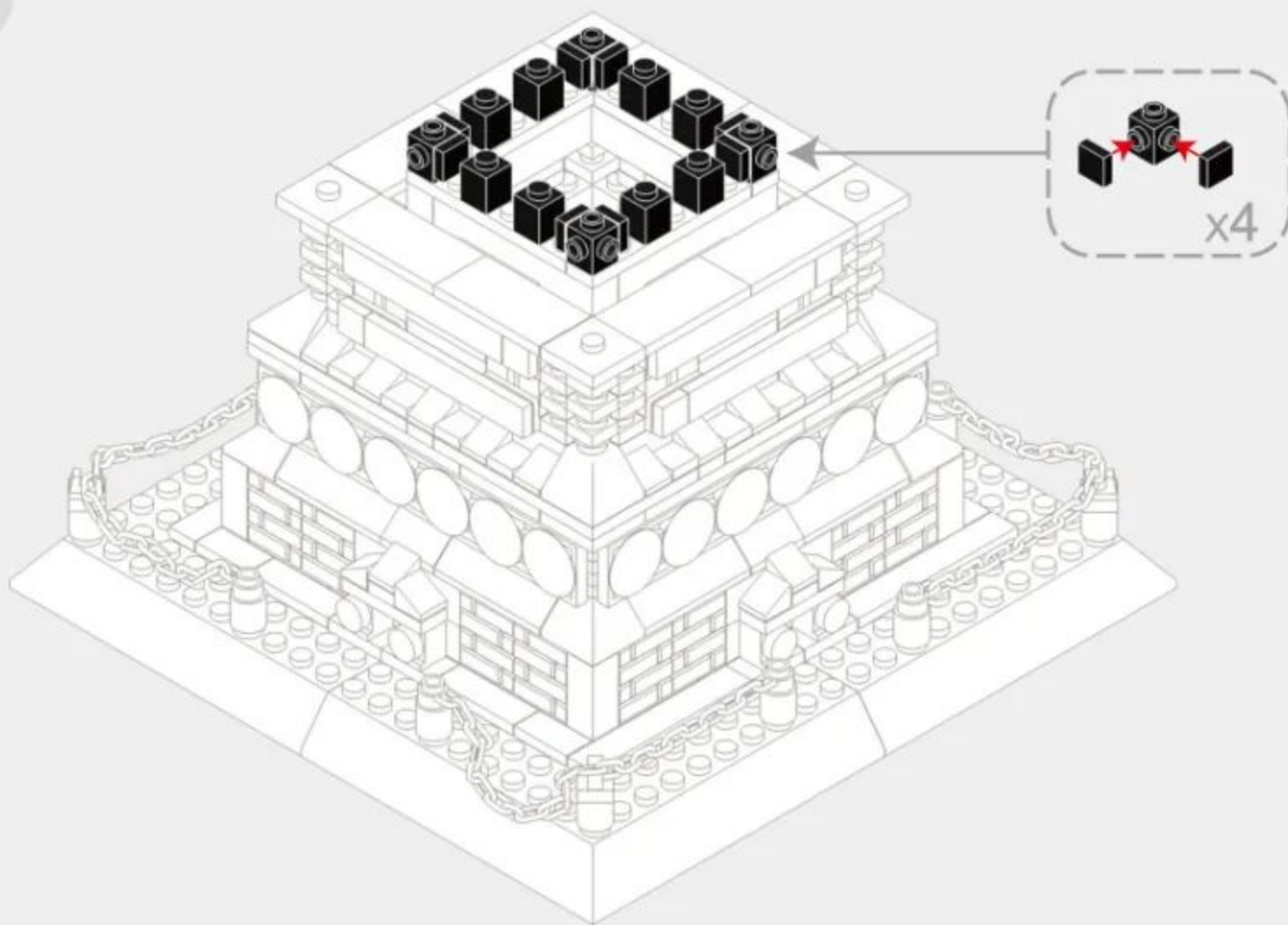
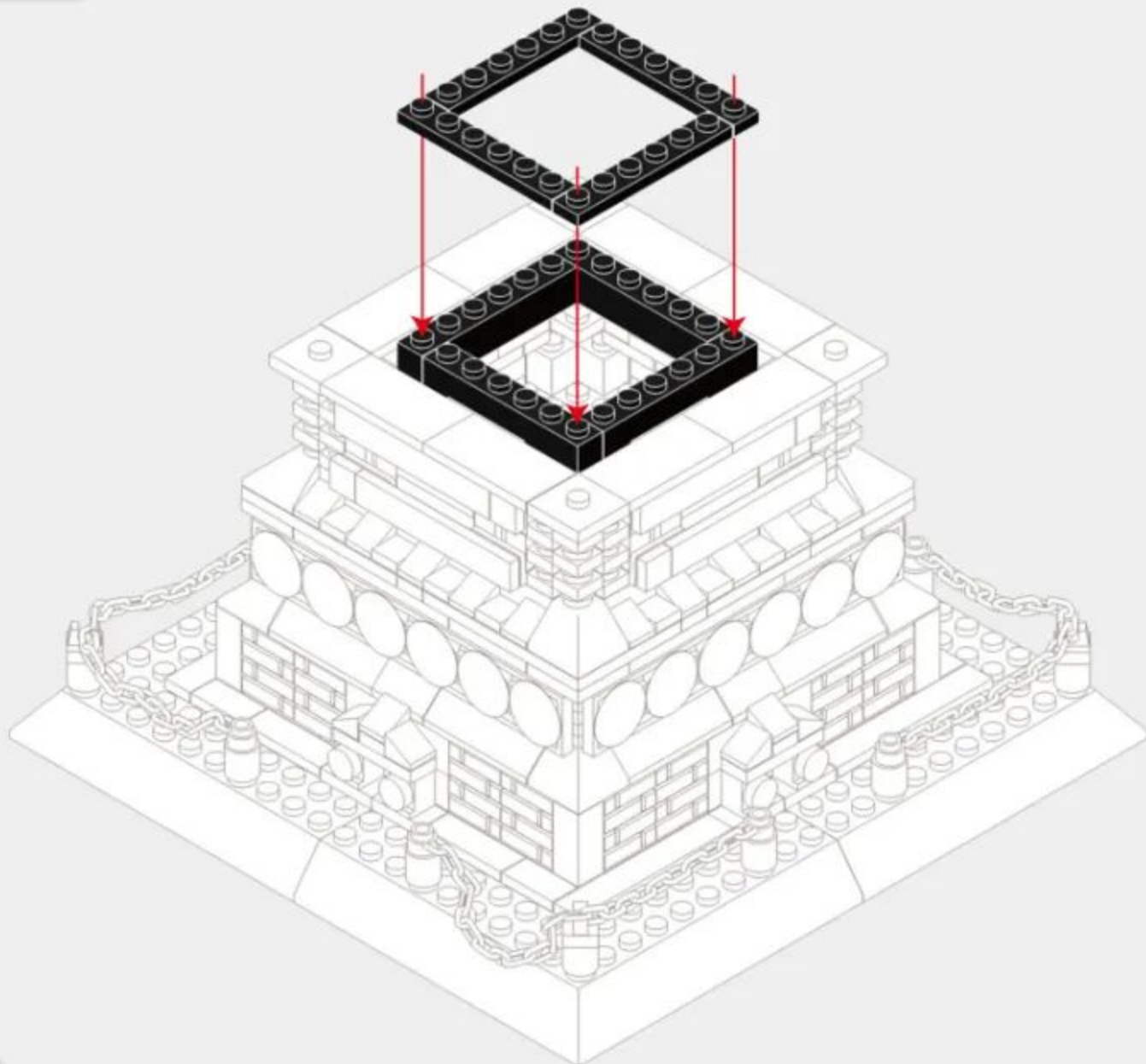
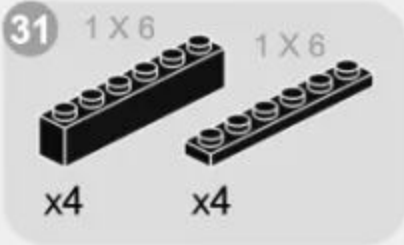

33 1 X 6
x8

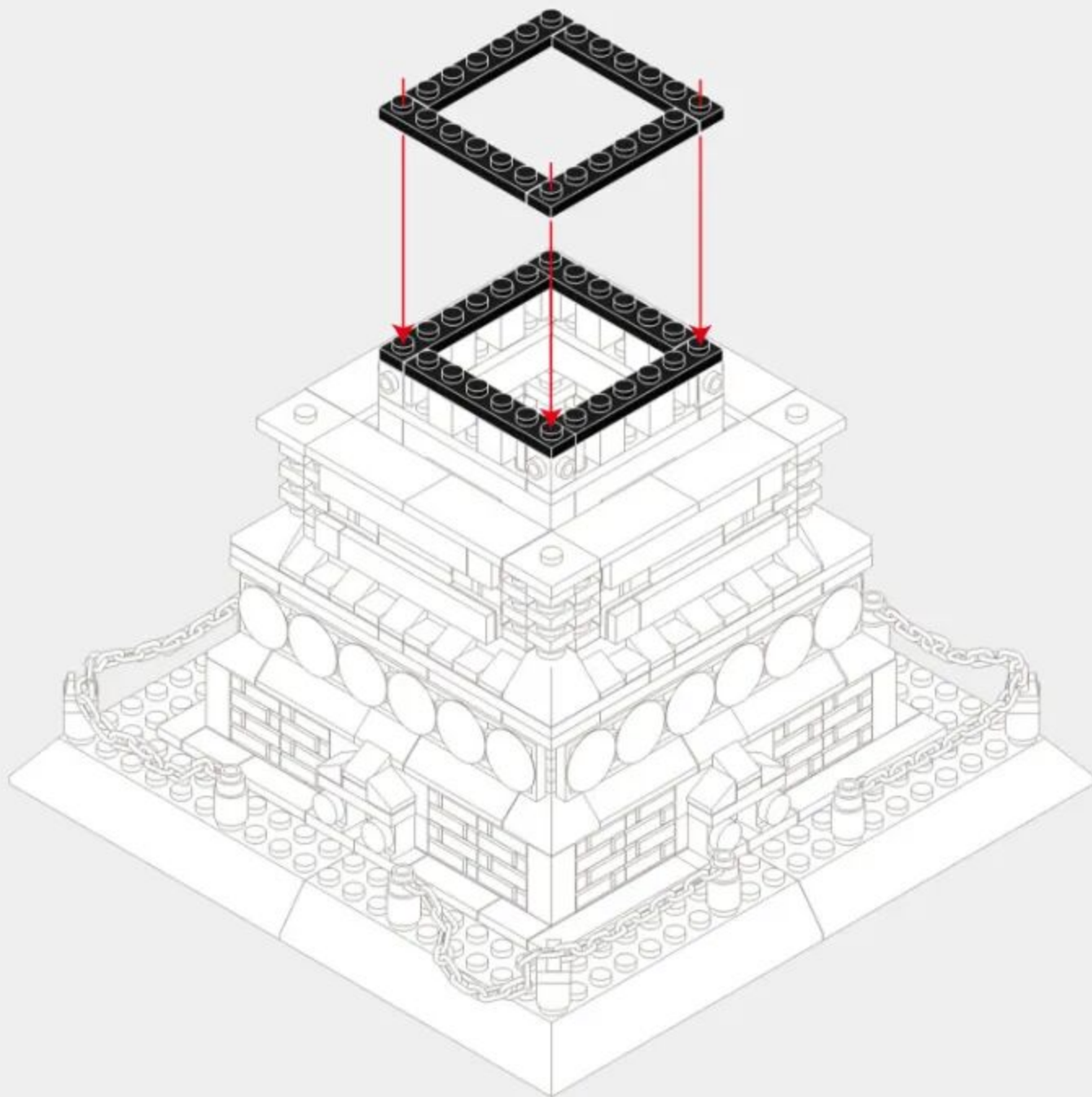

34
x4 x4

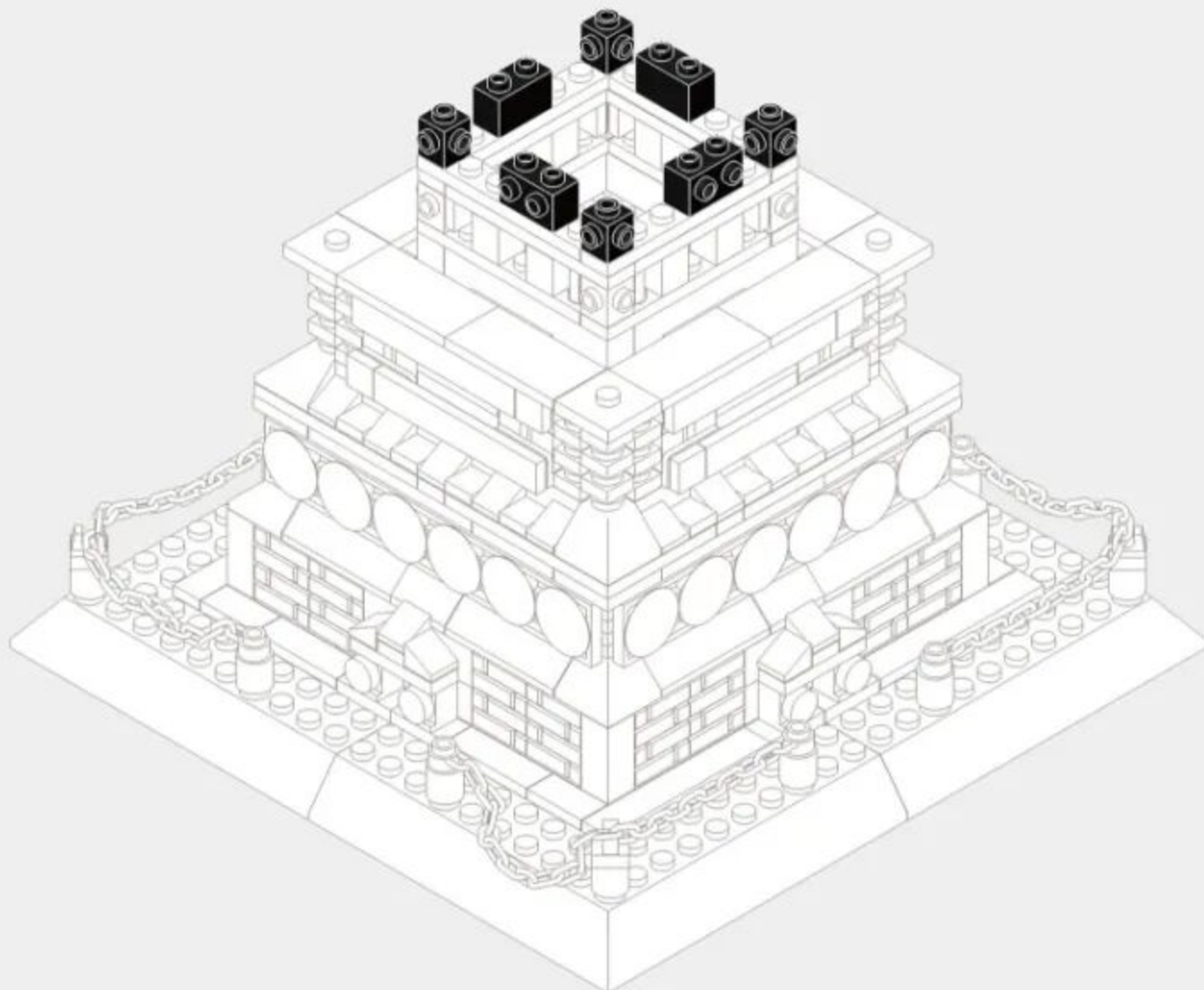

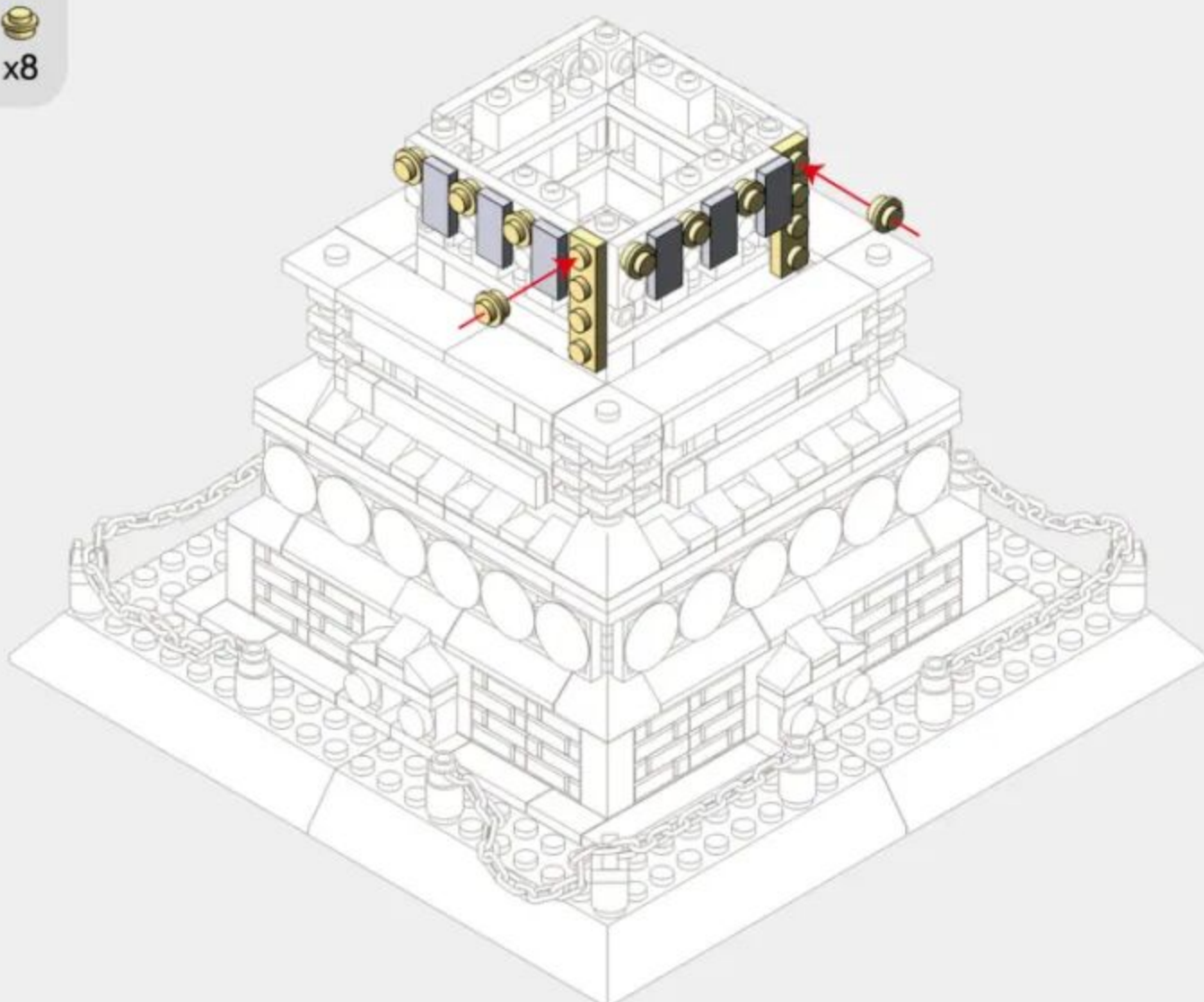
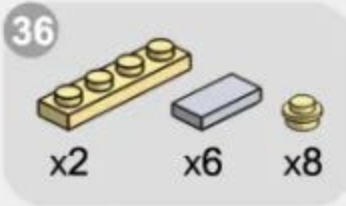
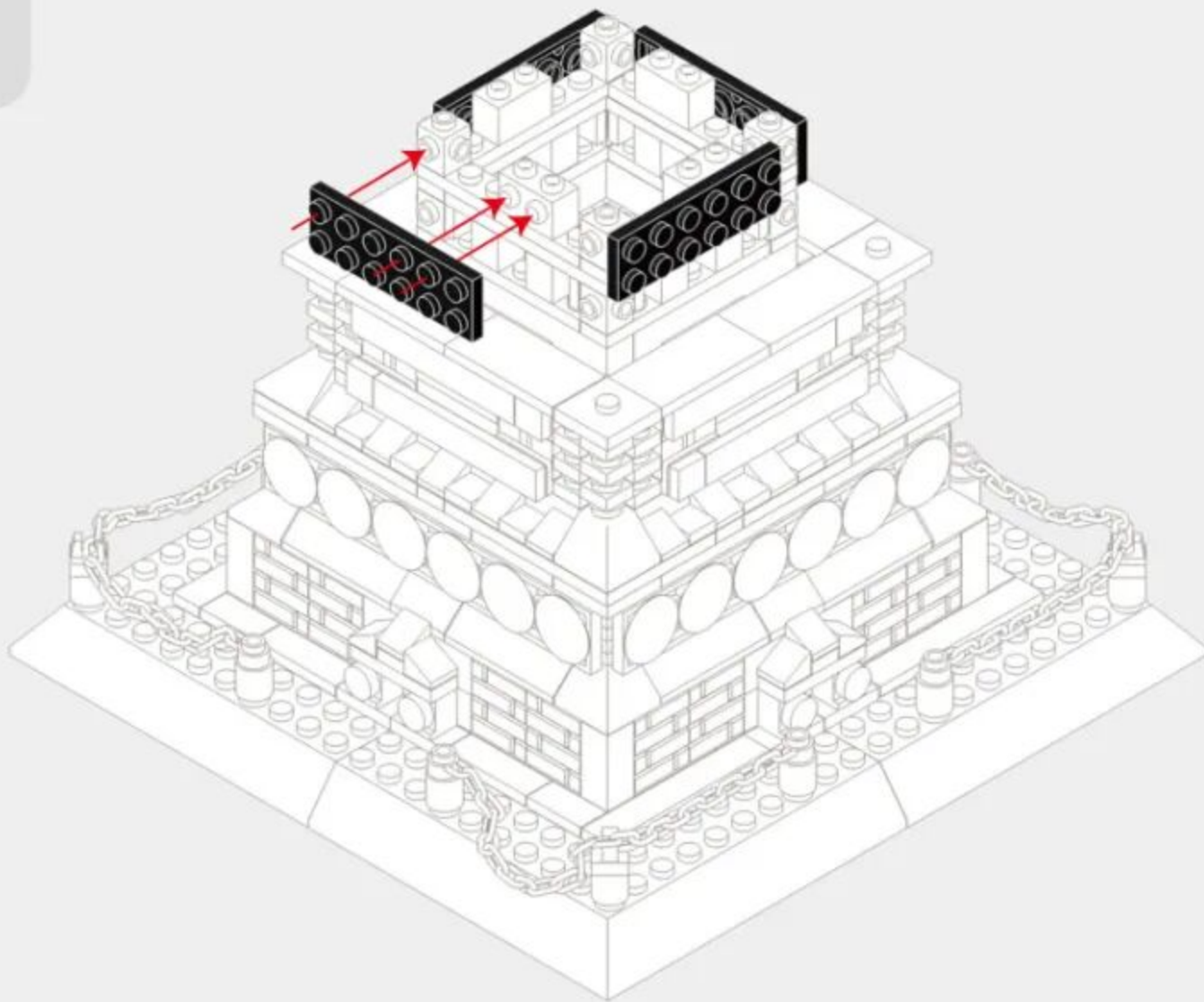

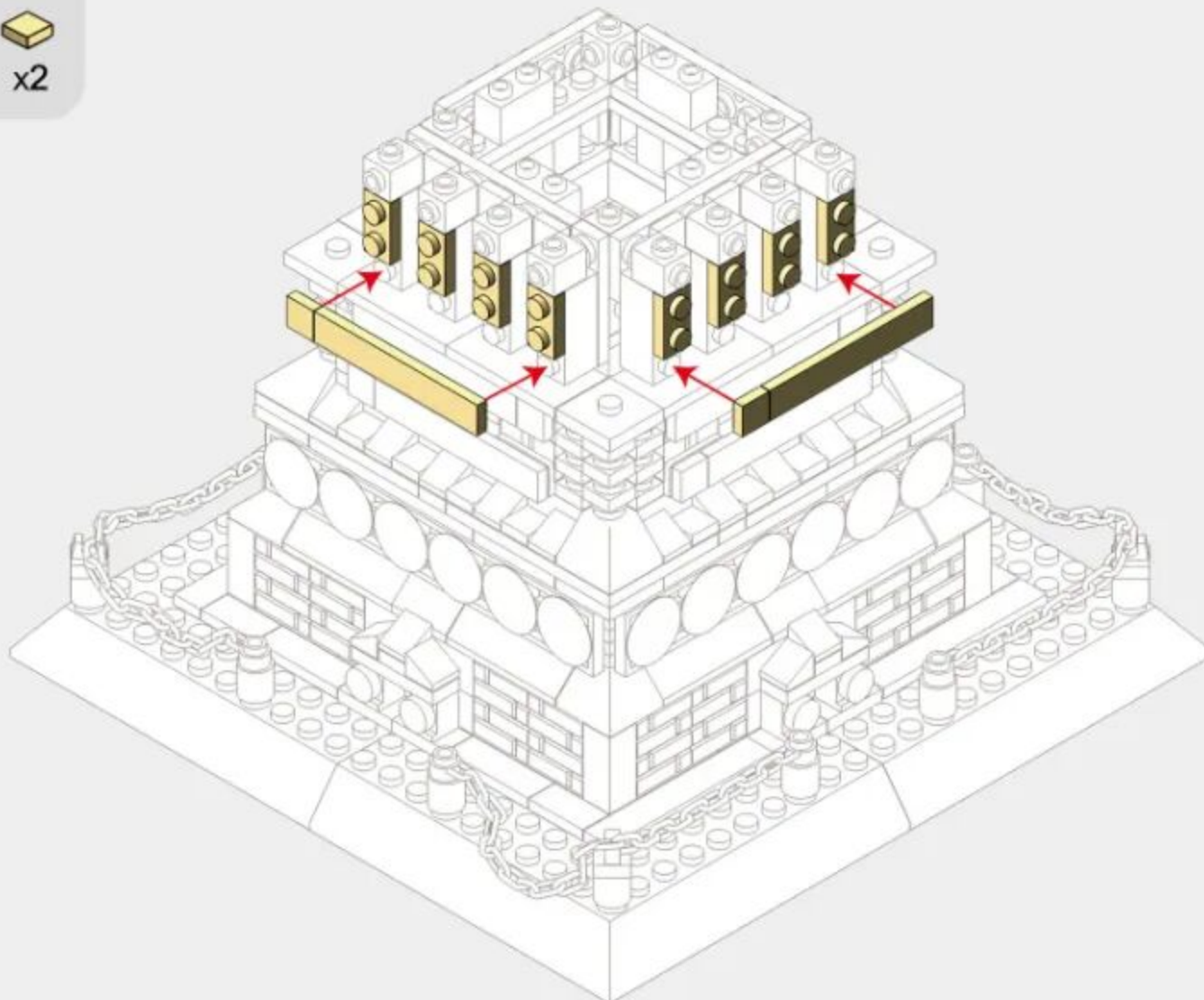
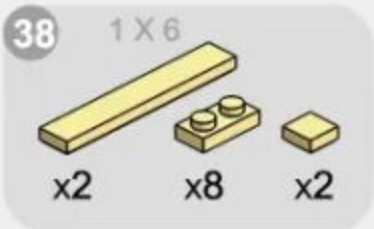
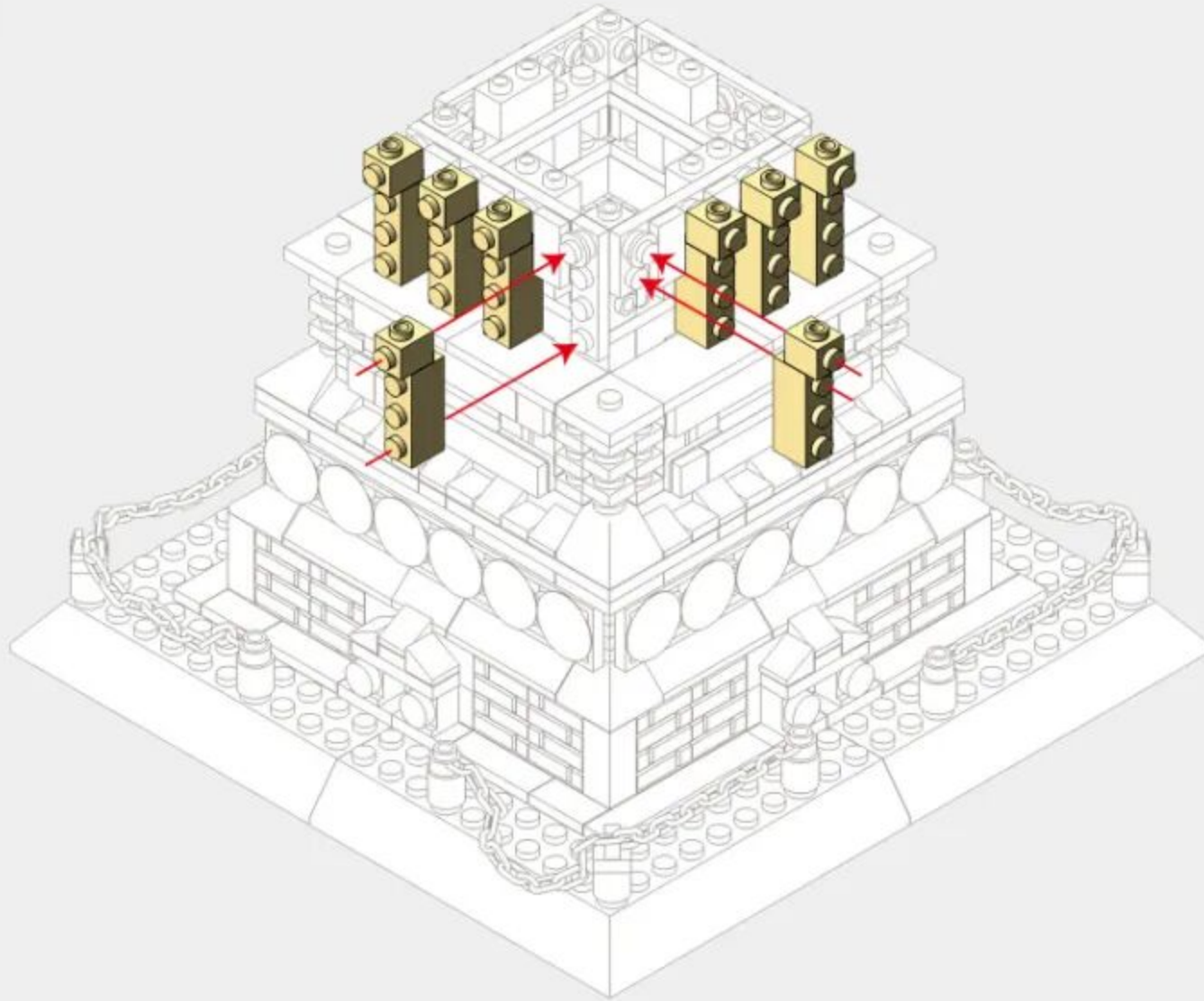

39



x16

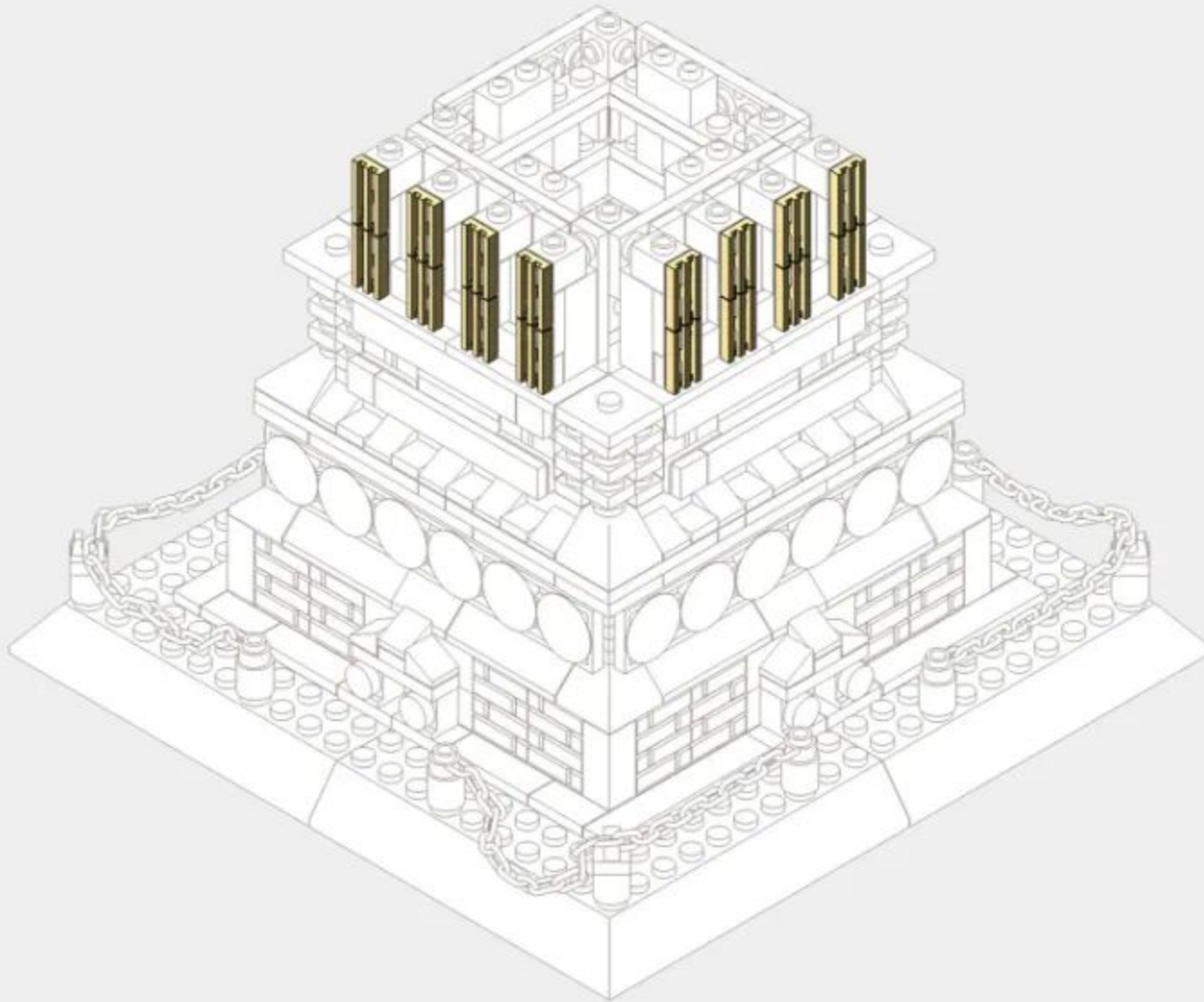

40



x2



x6



x8

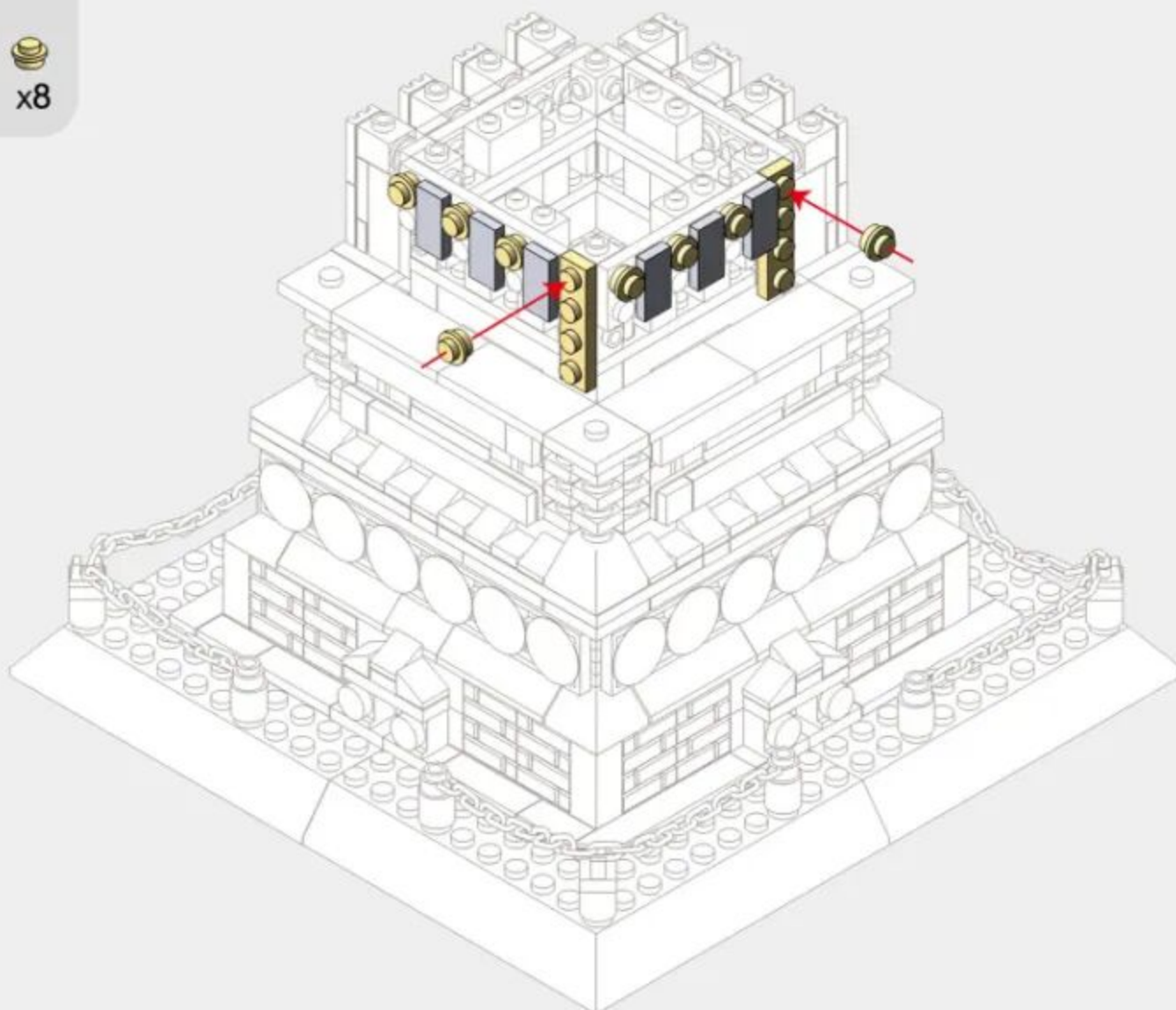

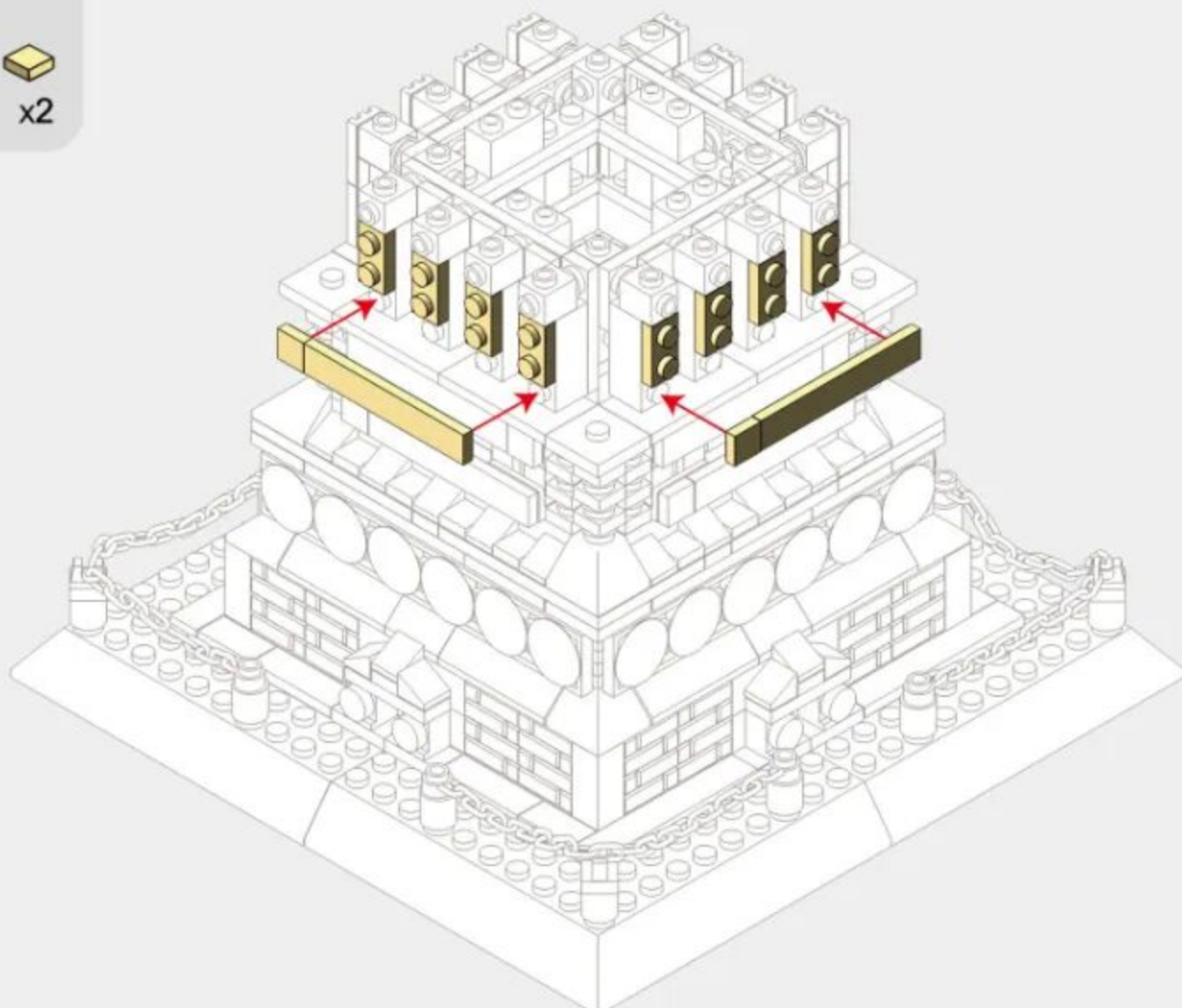
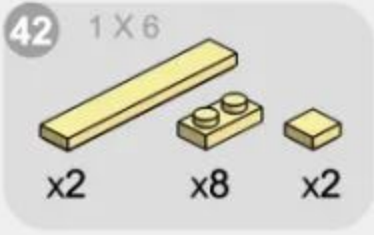
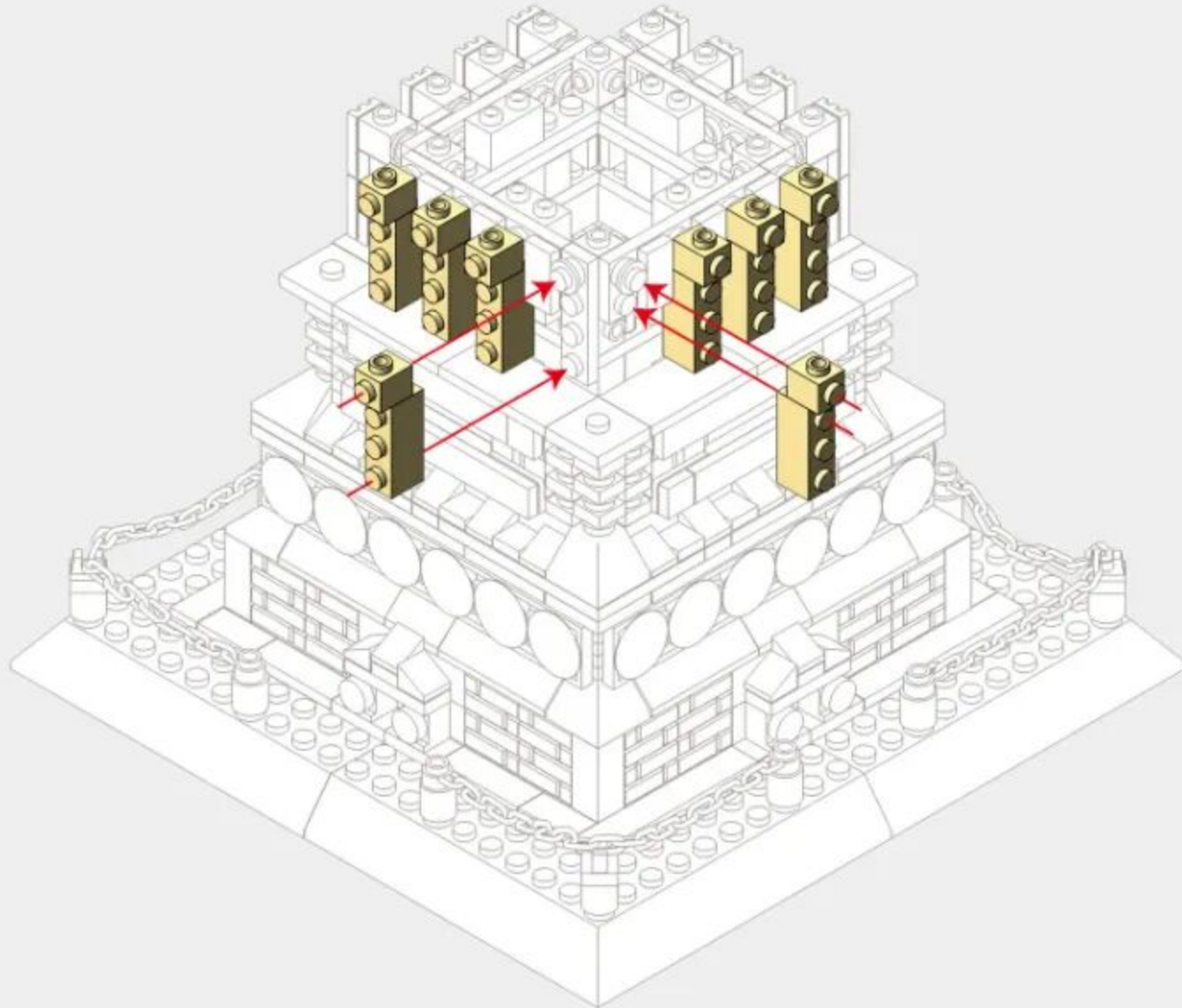
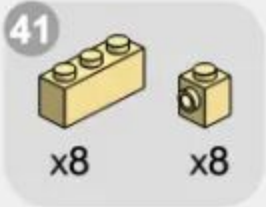

43
x16

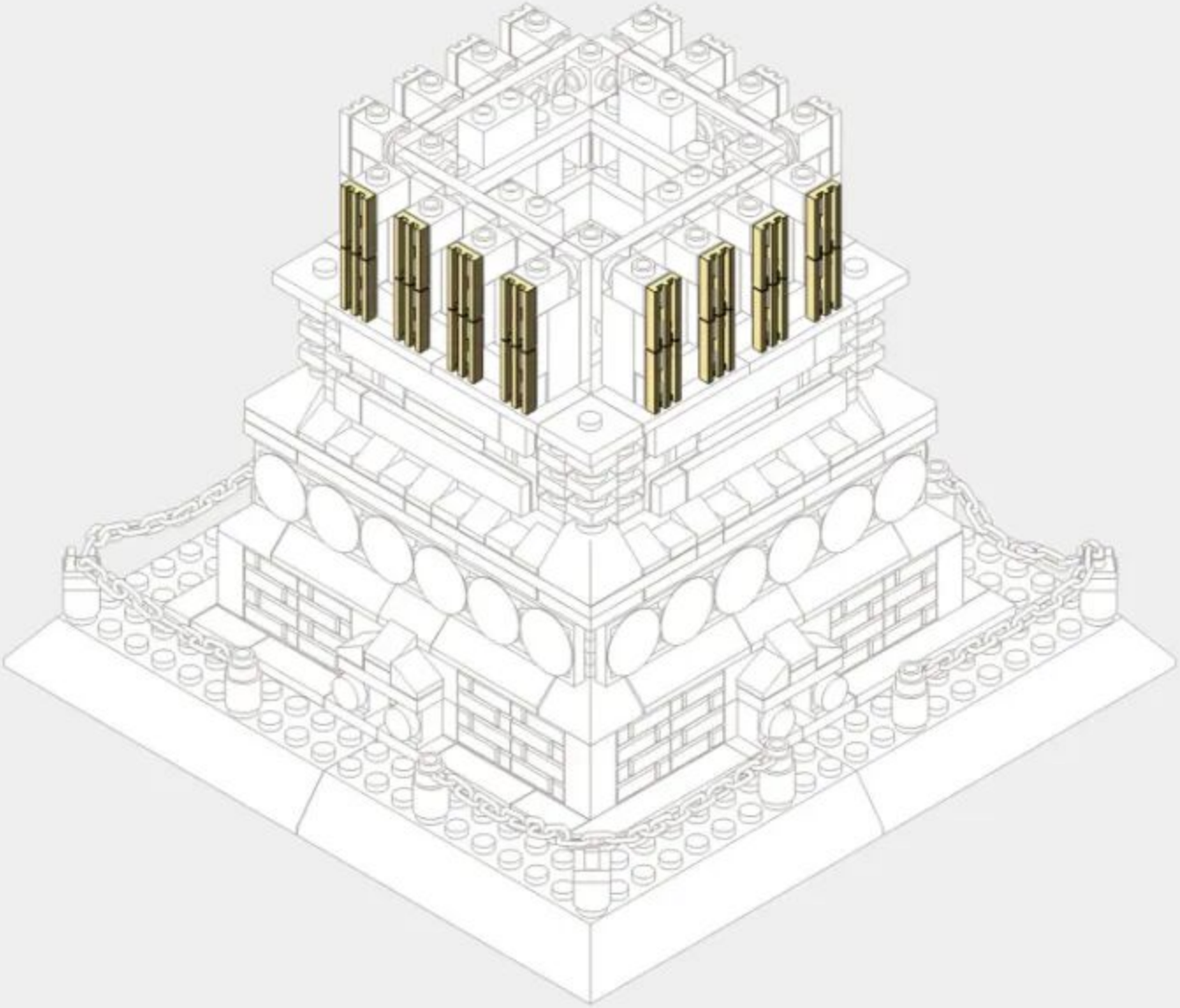

44
x16

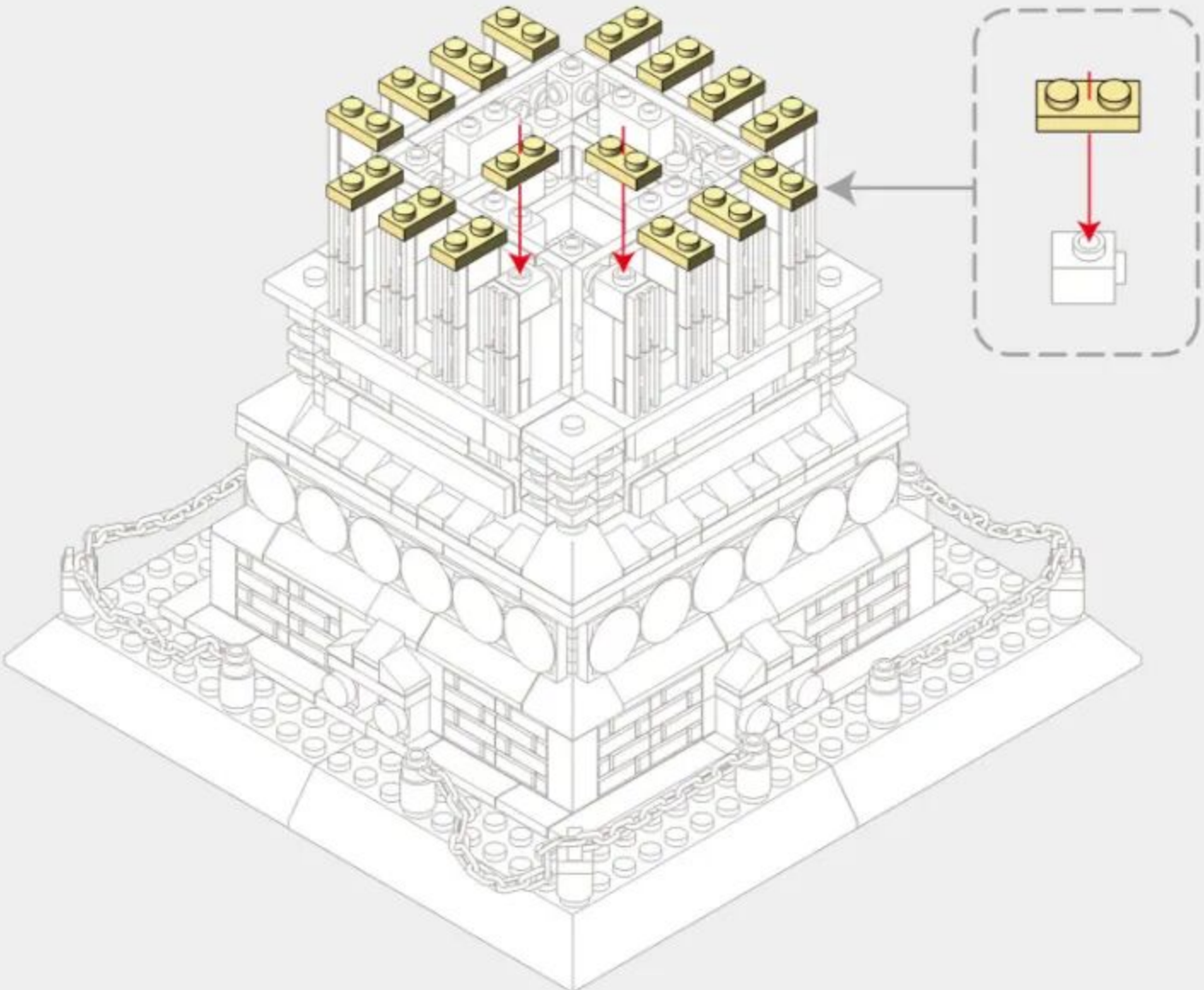

- 45
-  x8
 -  x20
 -  x20
 -  x60

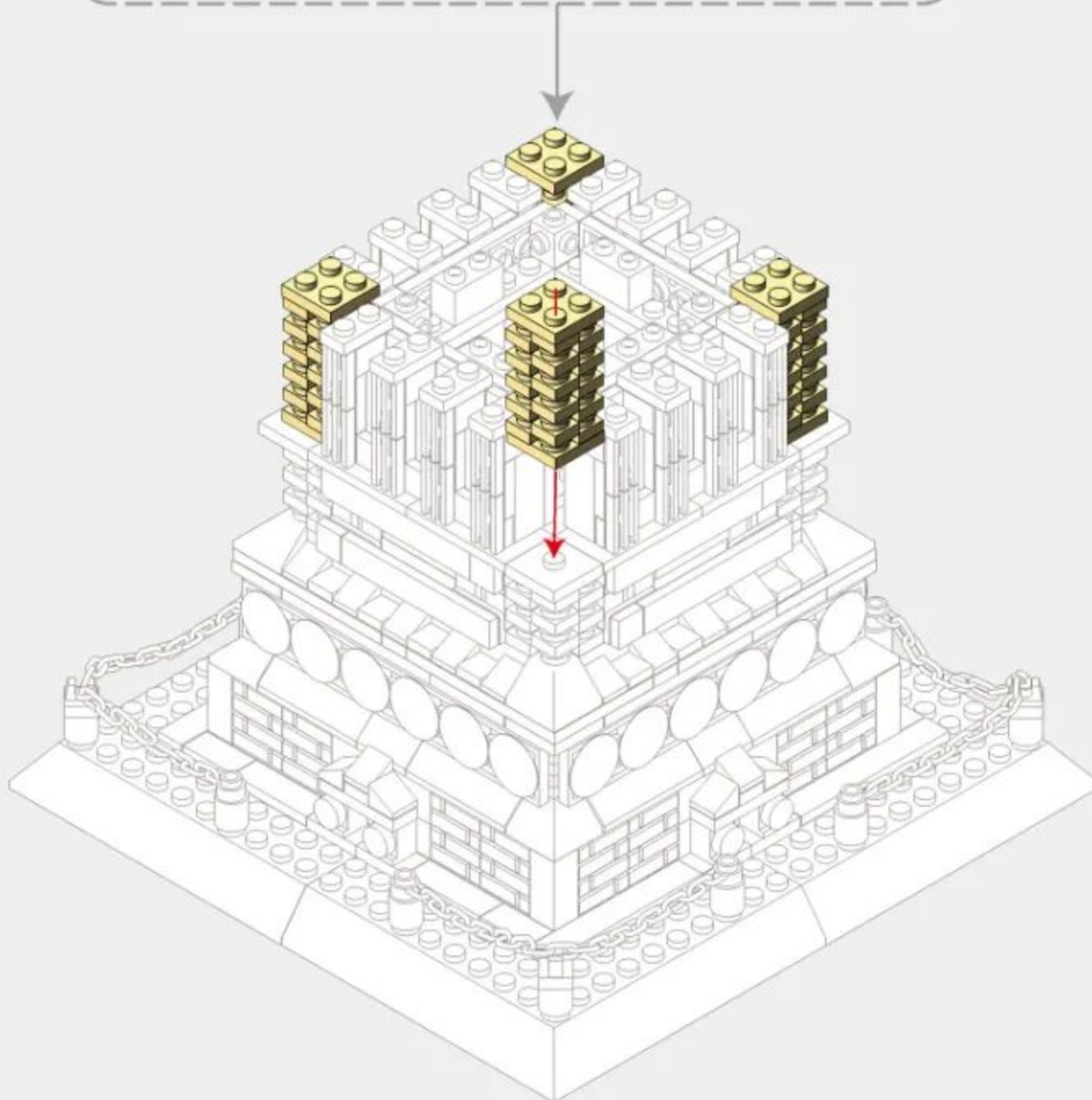
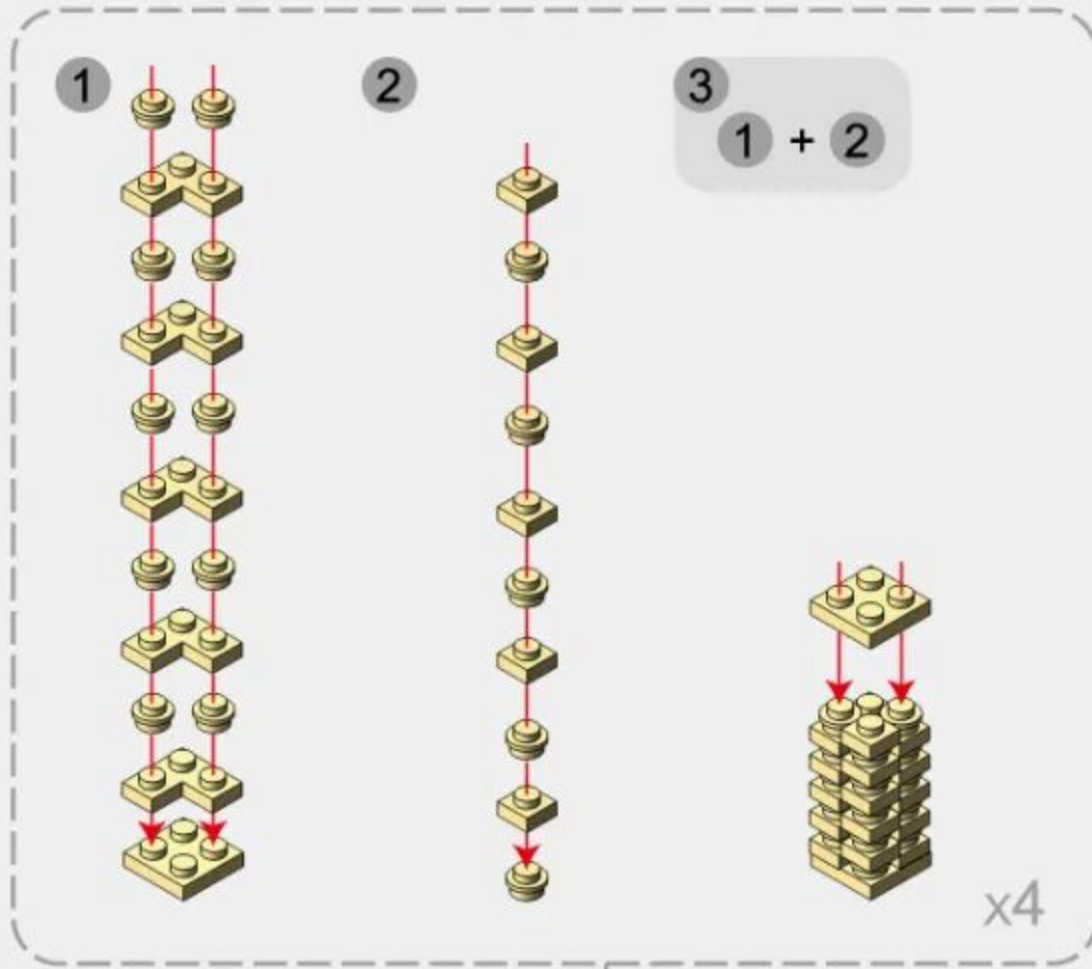

46

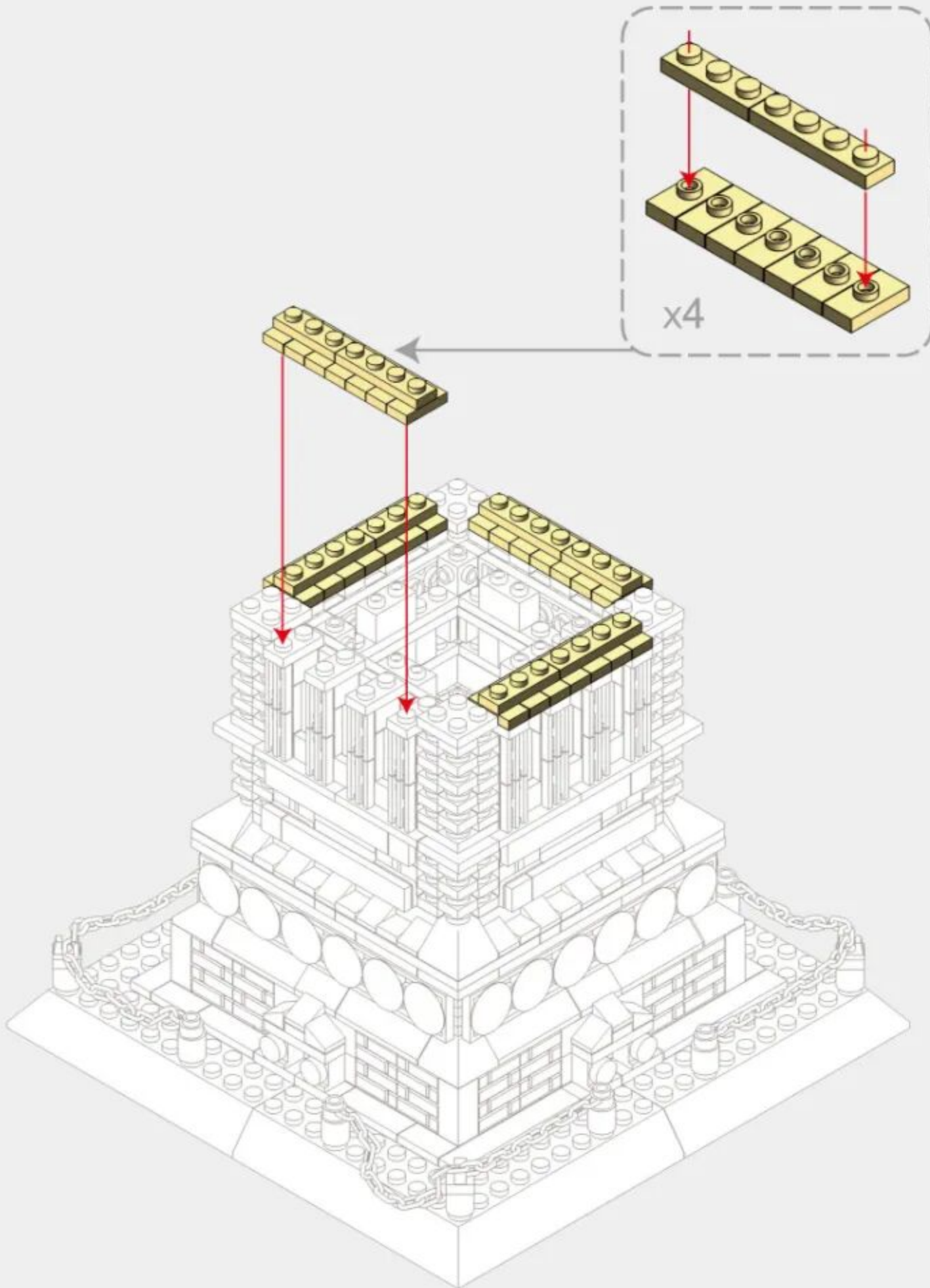

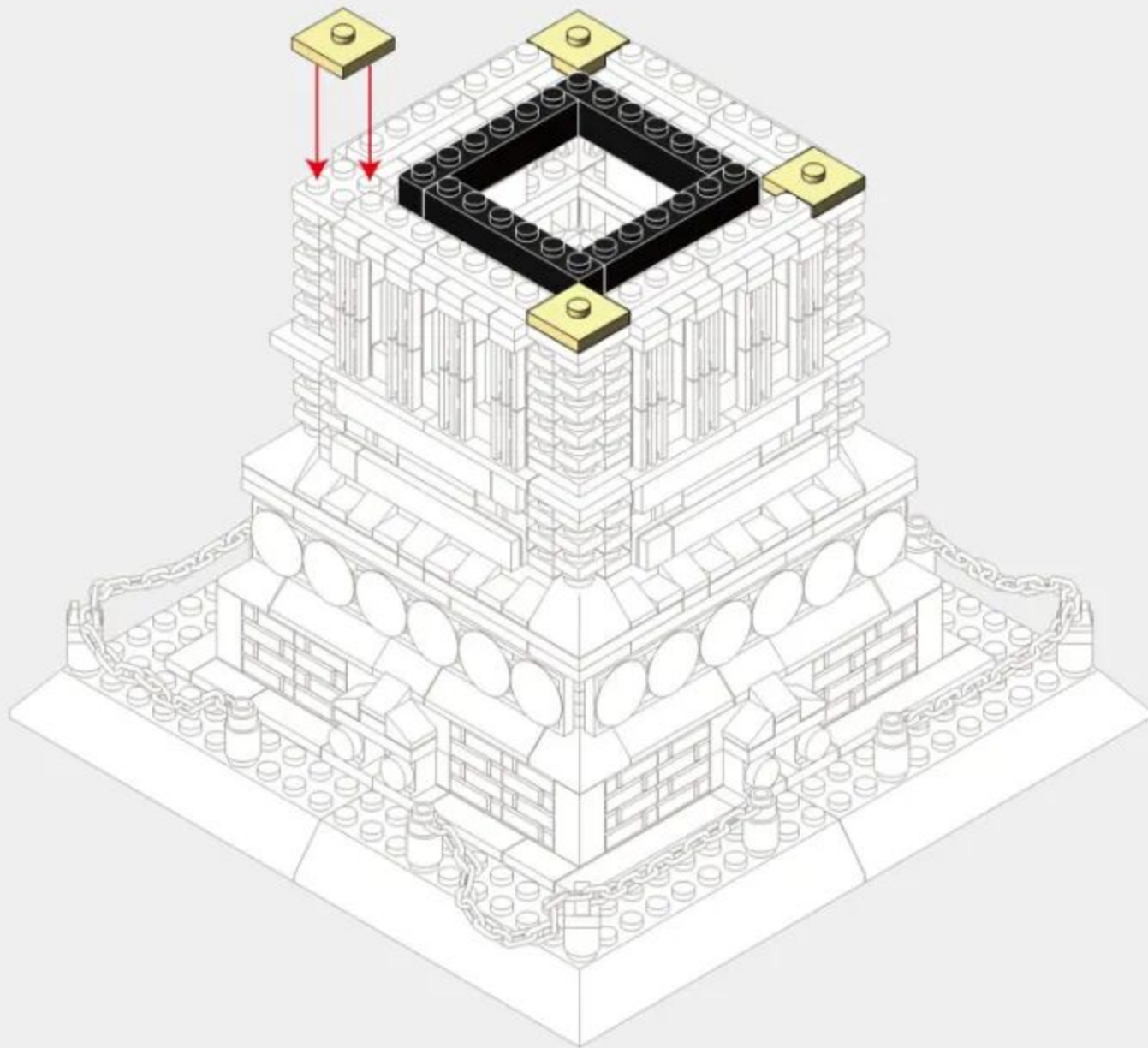
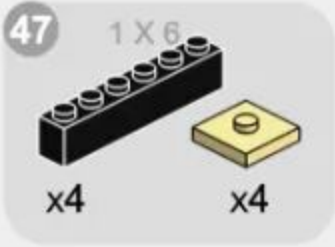

48

2 X 10

1 X 6

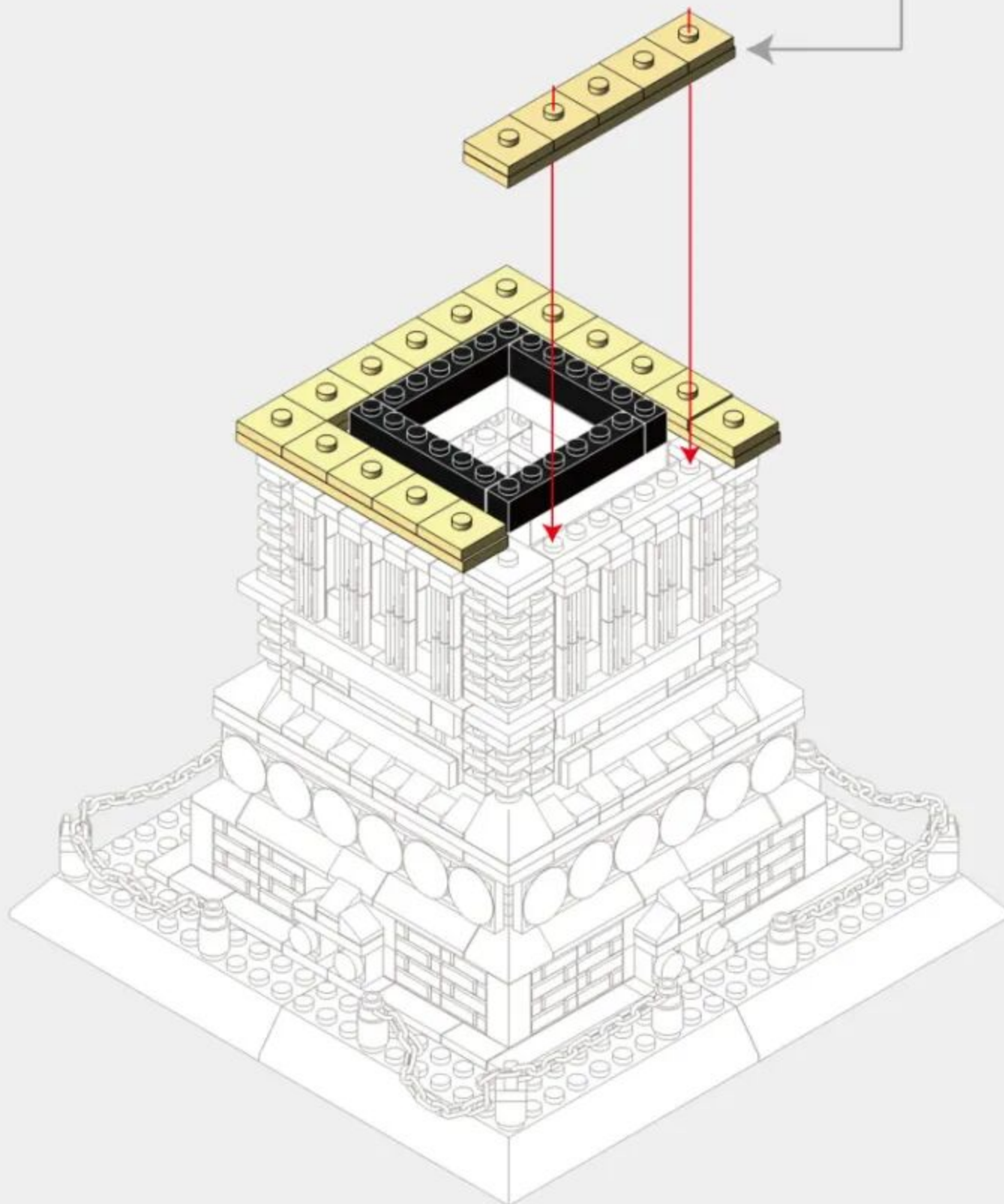
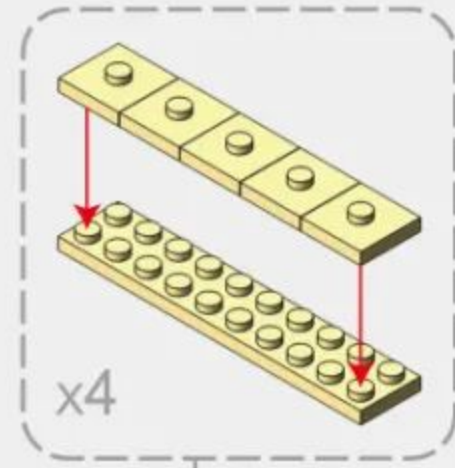
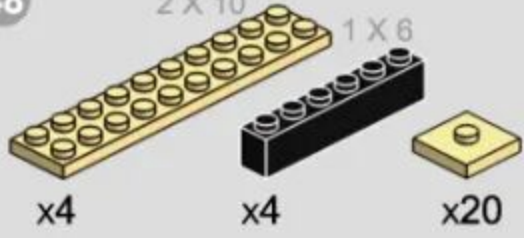

49

2 X 8

4 X 6

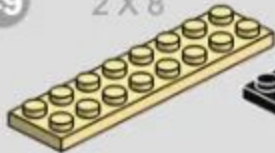

x4

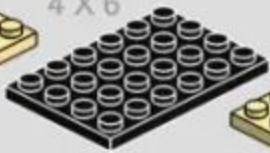

x4



x4



x4

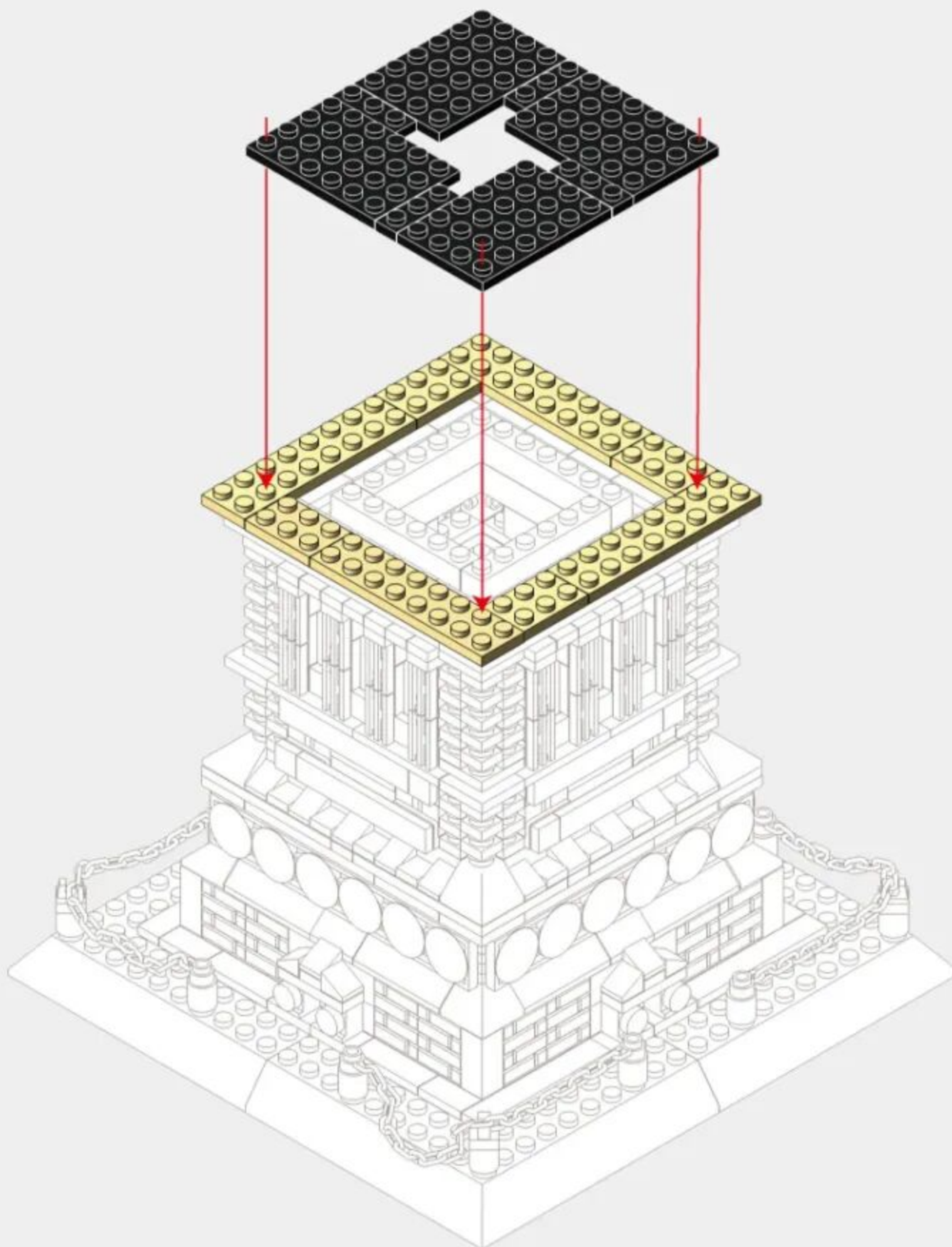

50

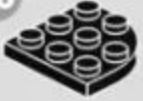

x4



x16



x4



x4

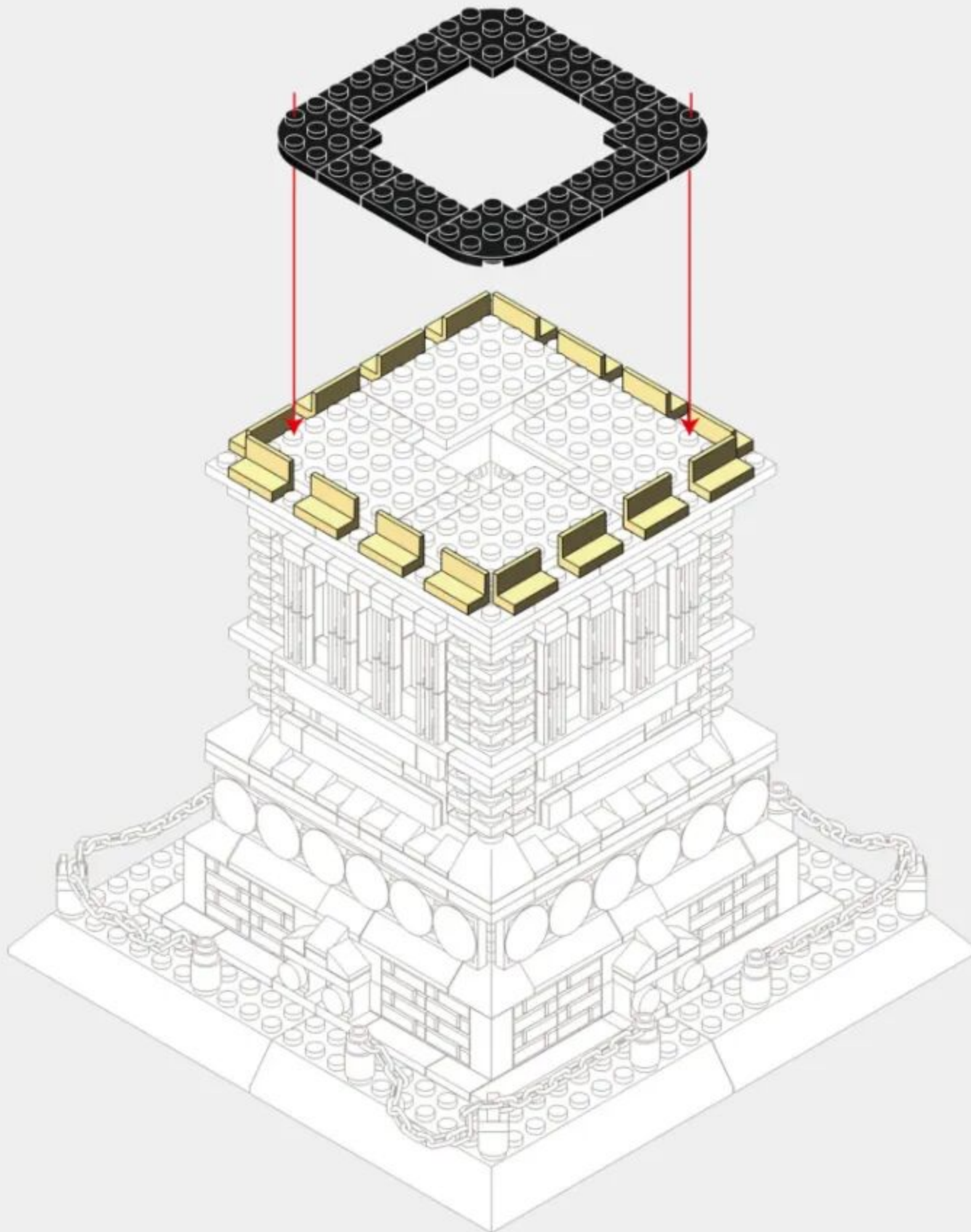

51



x6



x8



x4



x12



x36

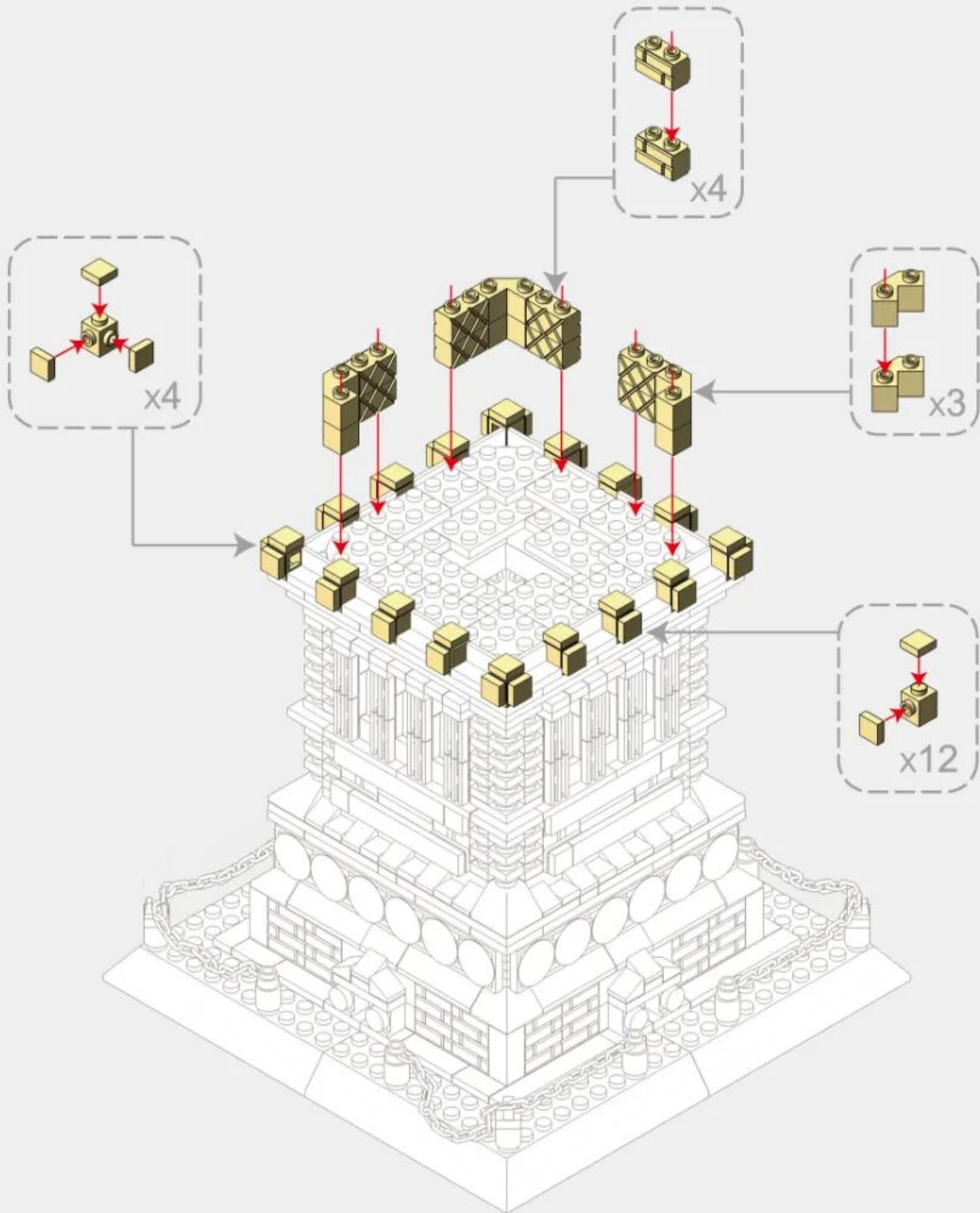

52

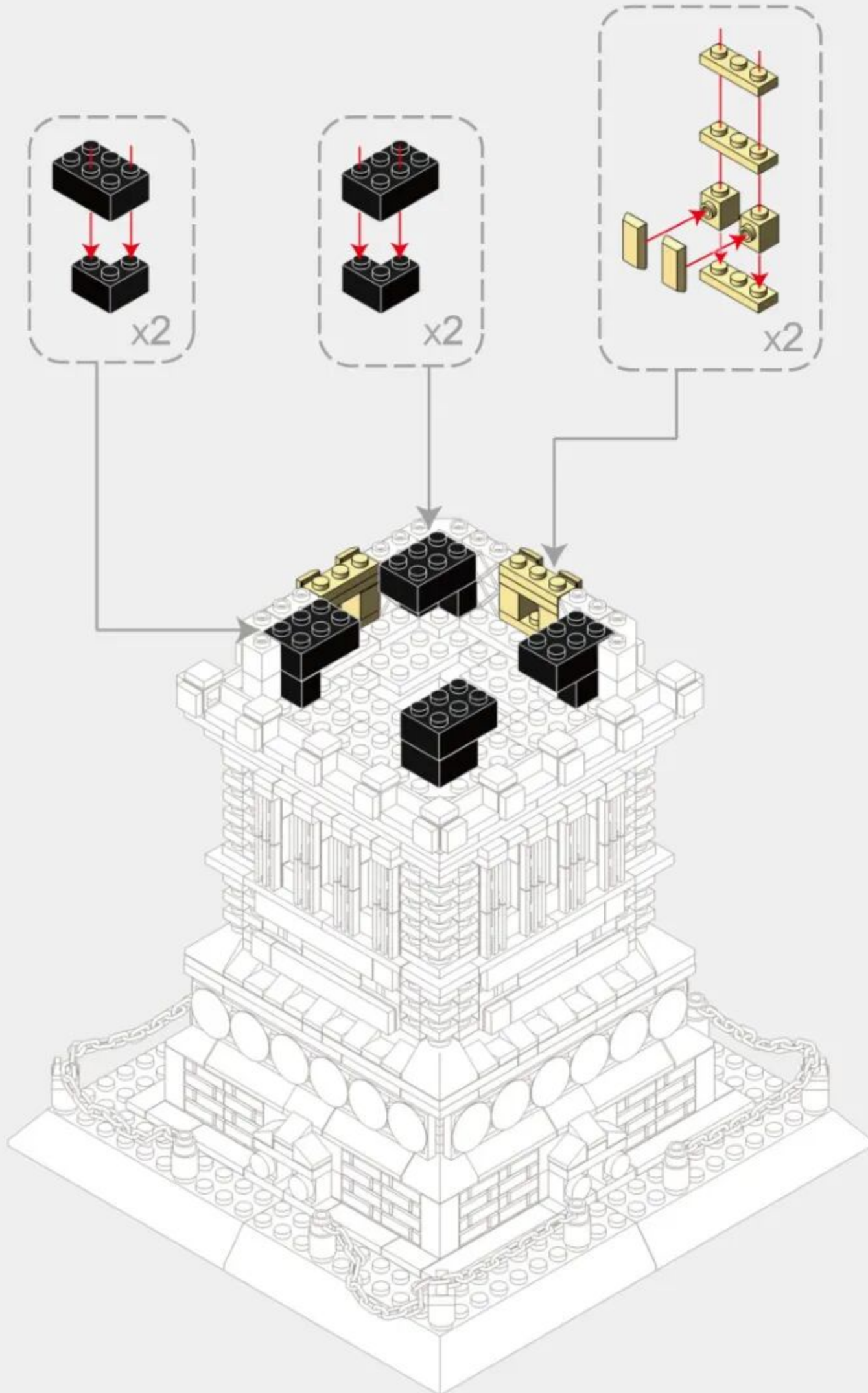

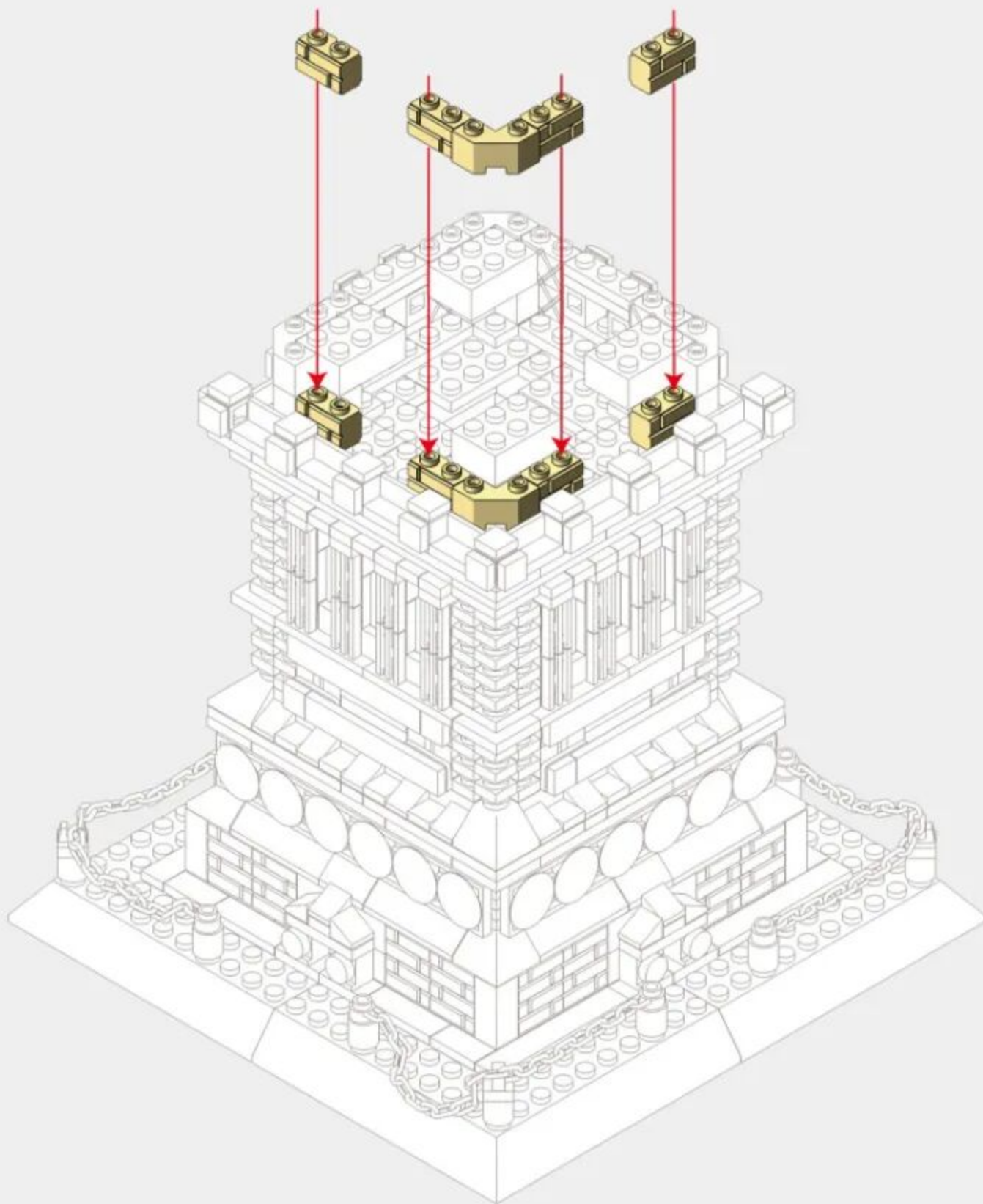

54

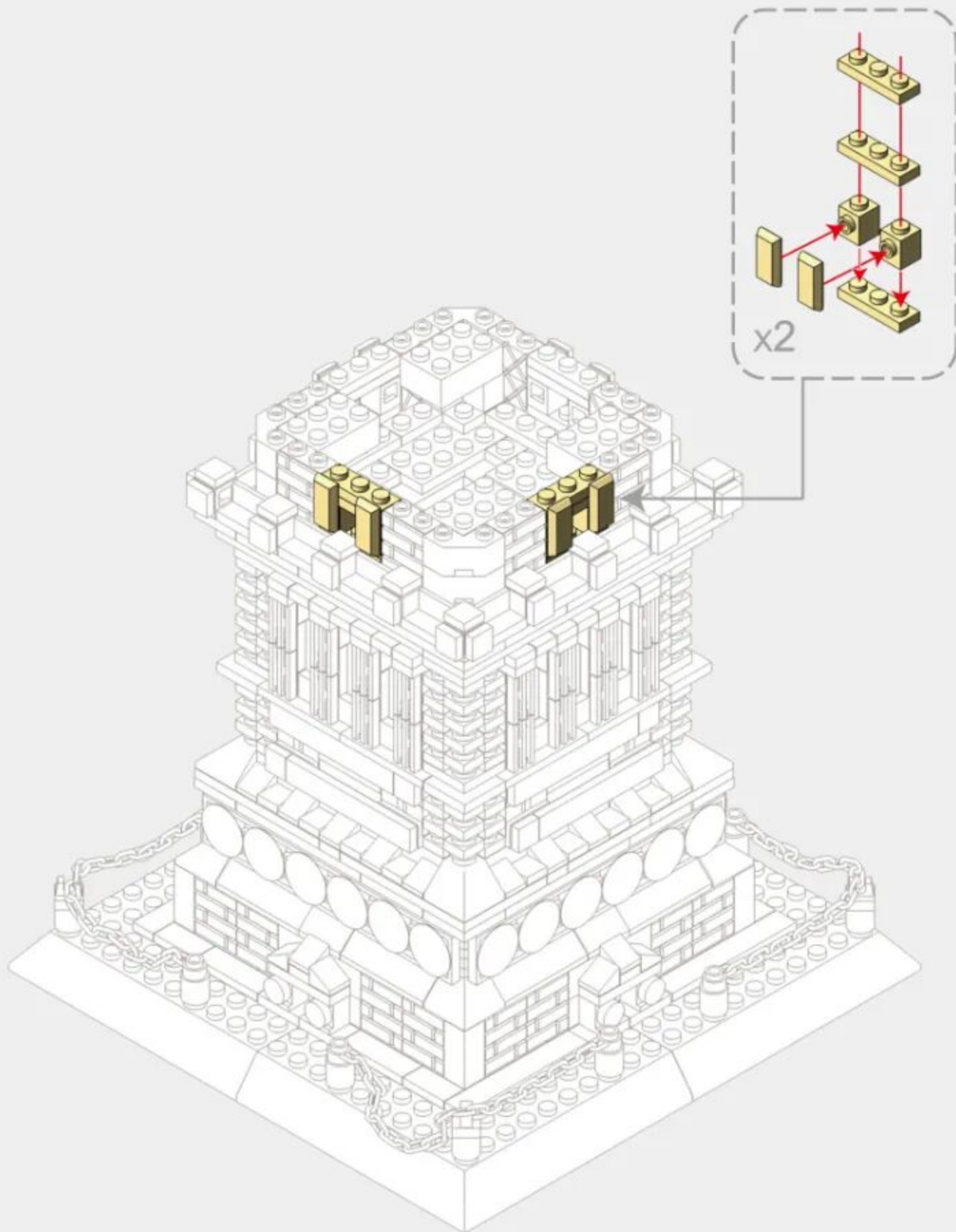

55

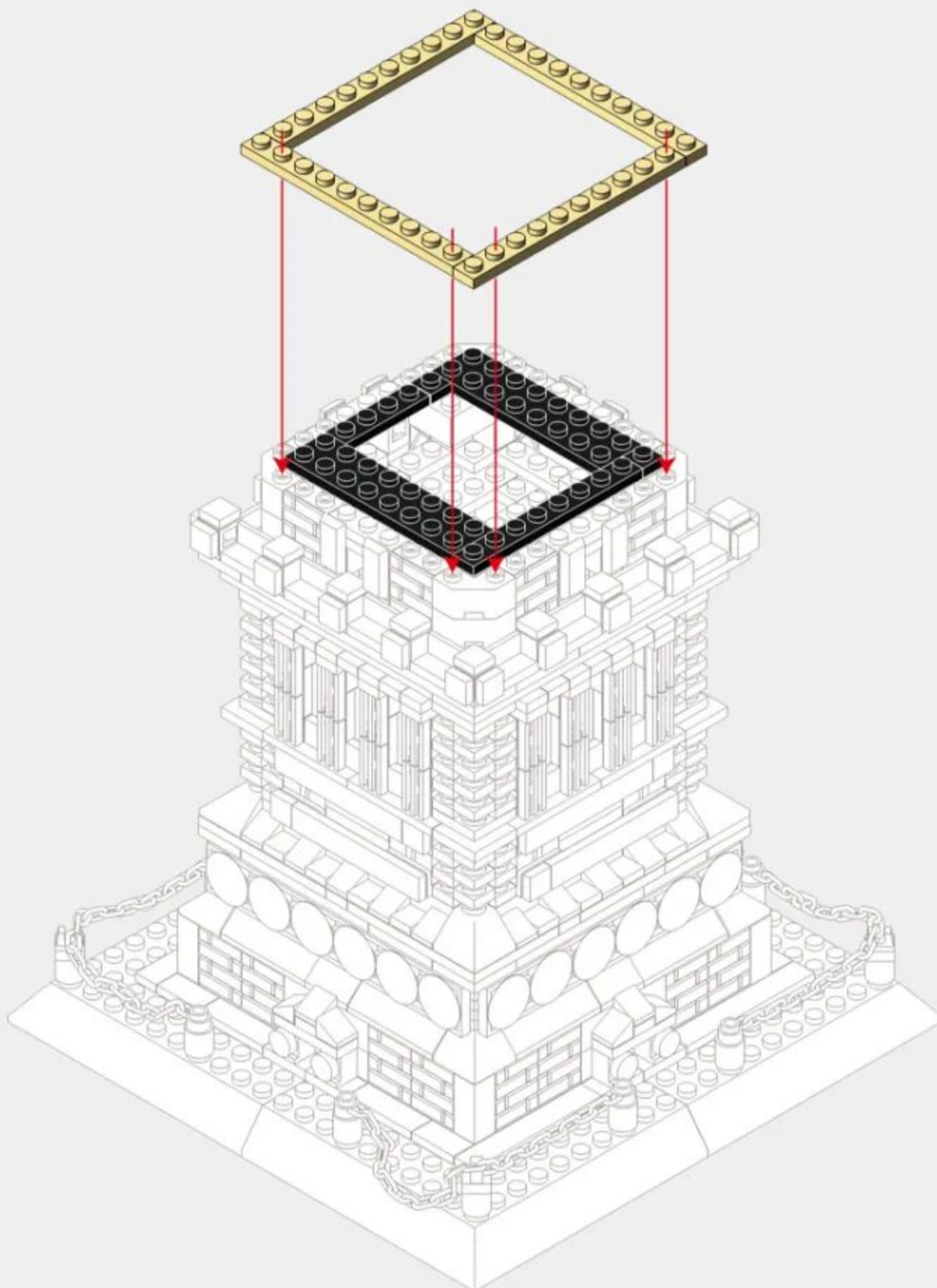
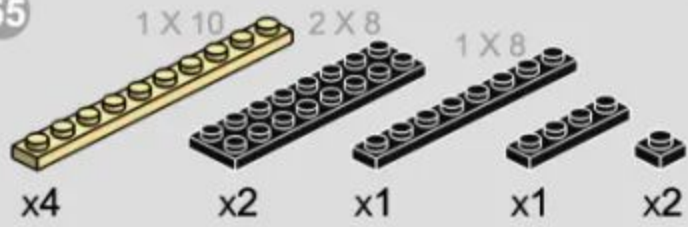

56 1 X 6 1 X 4
x4 x4 x4 x16

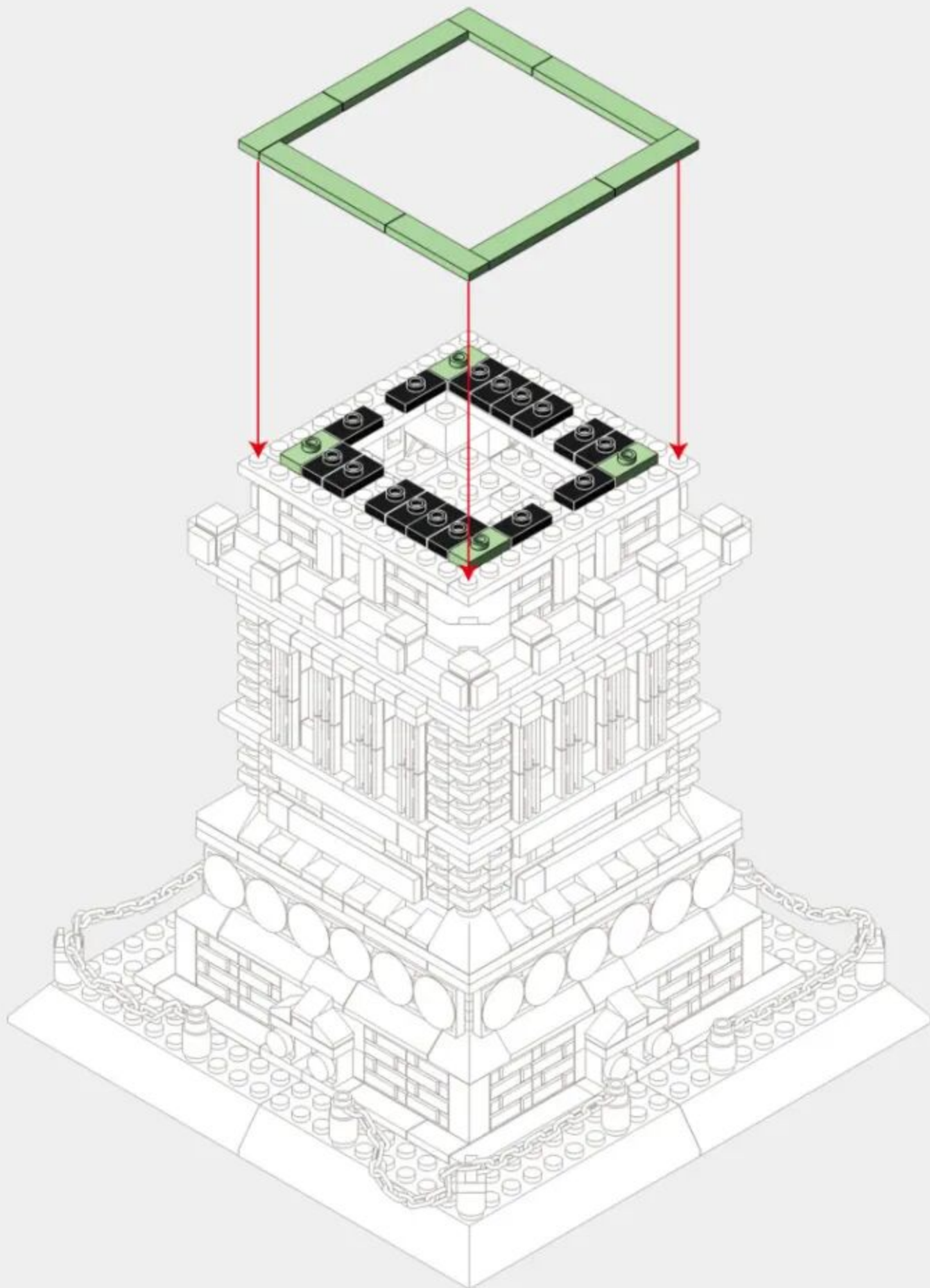

57 1x4
 x8 x14 x2

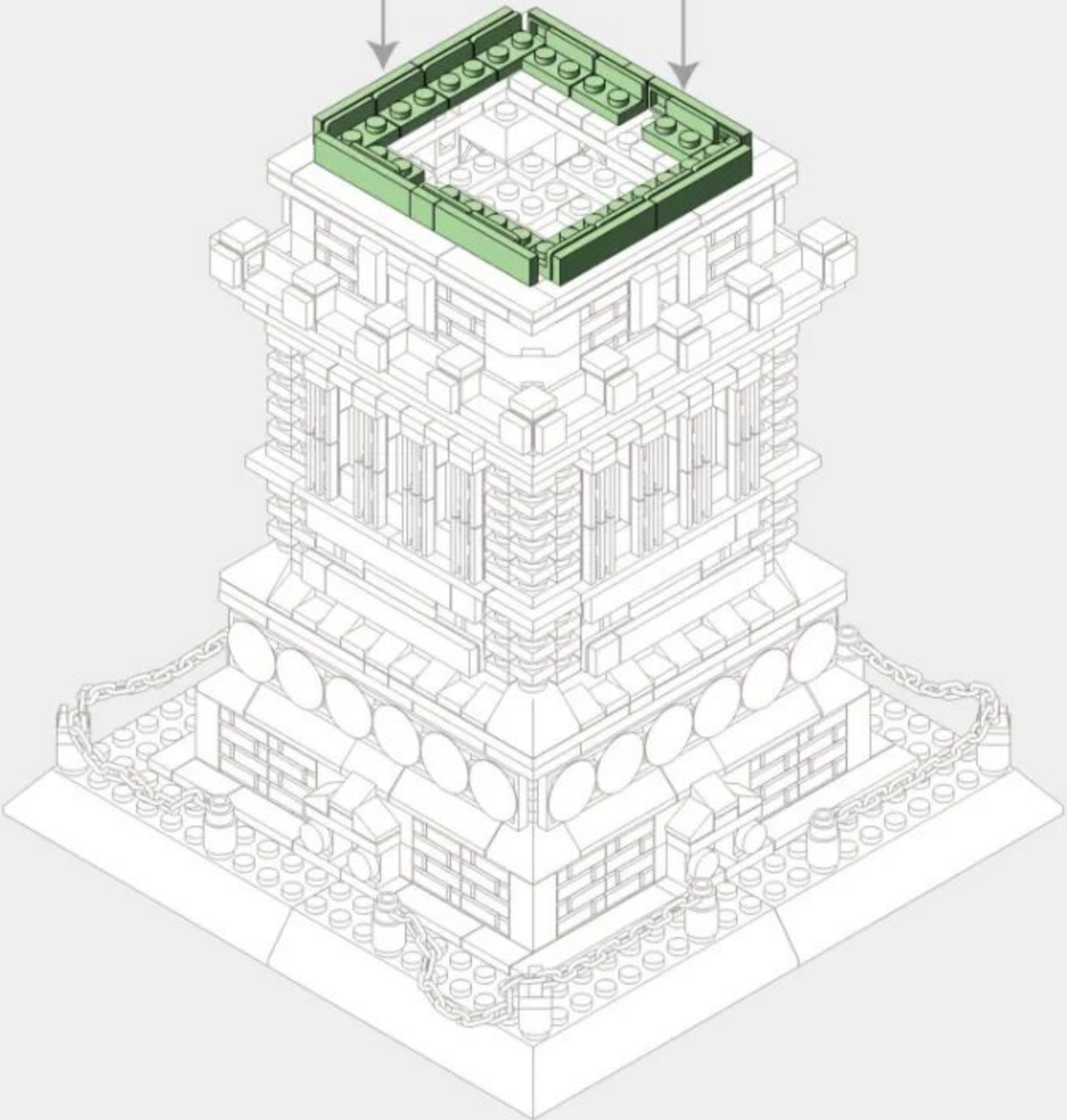
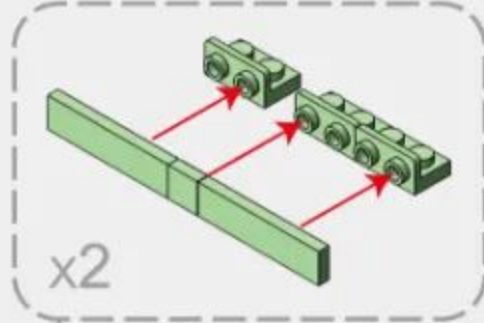
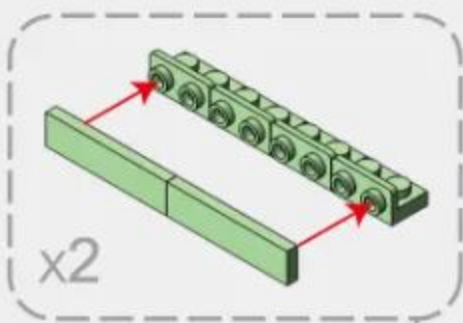

58

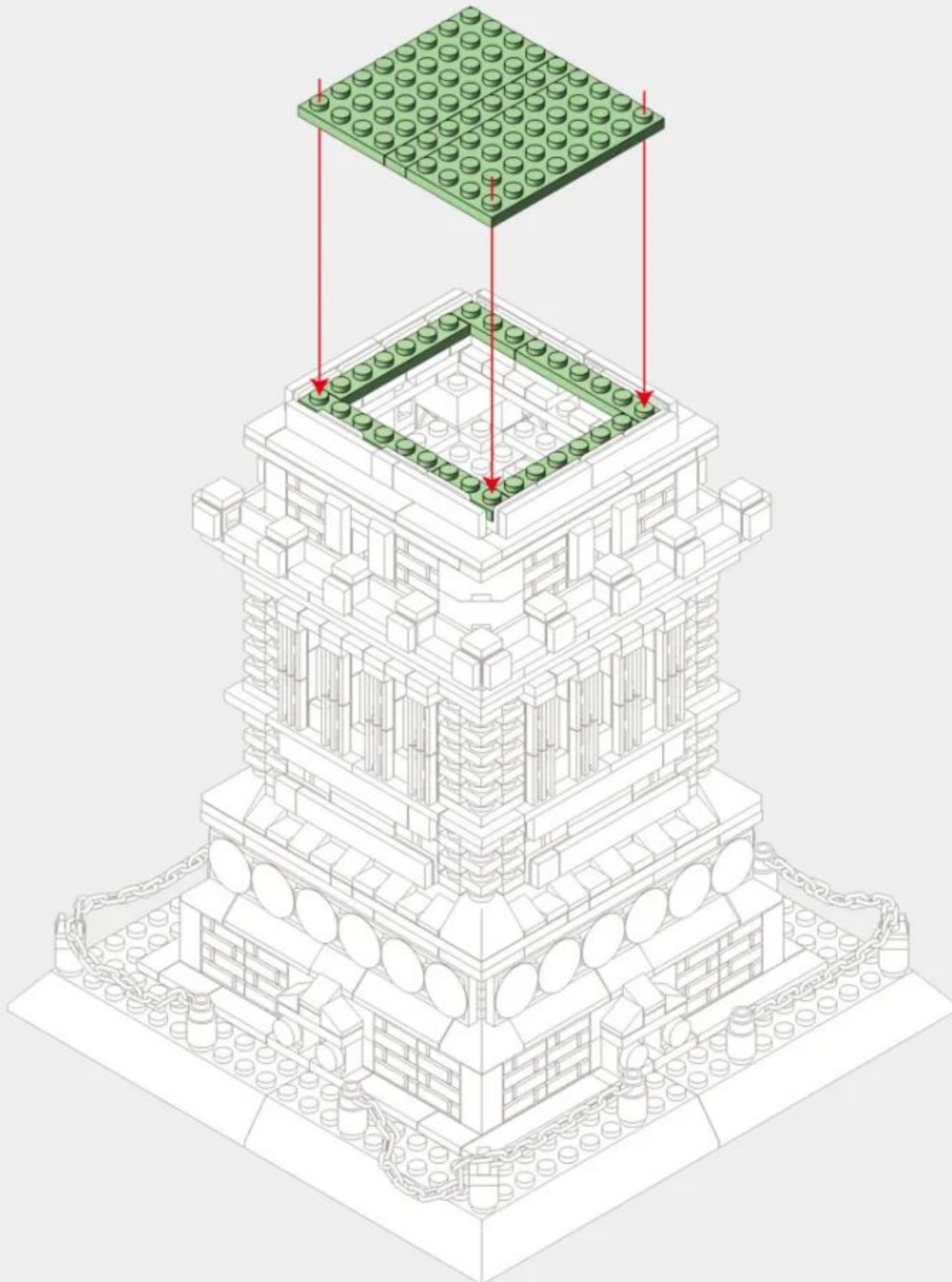
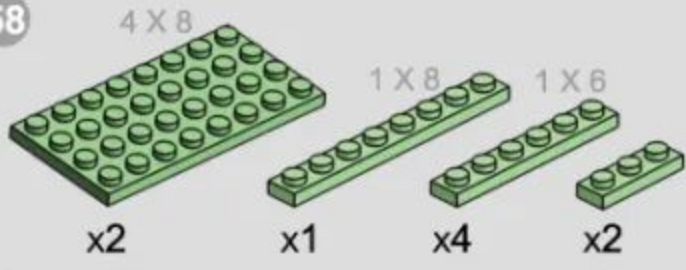

59



x1



x1



x1



x1



x1



x3

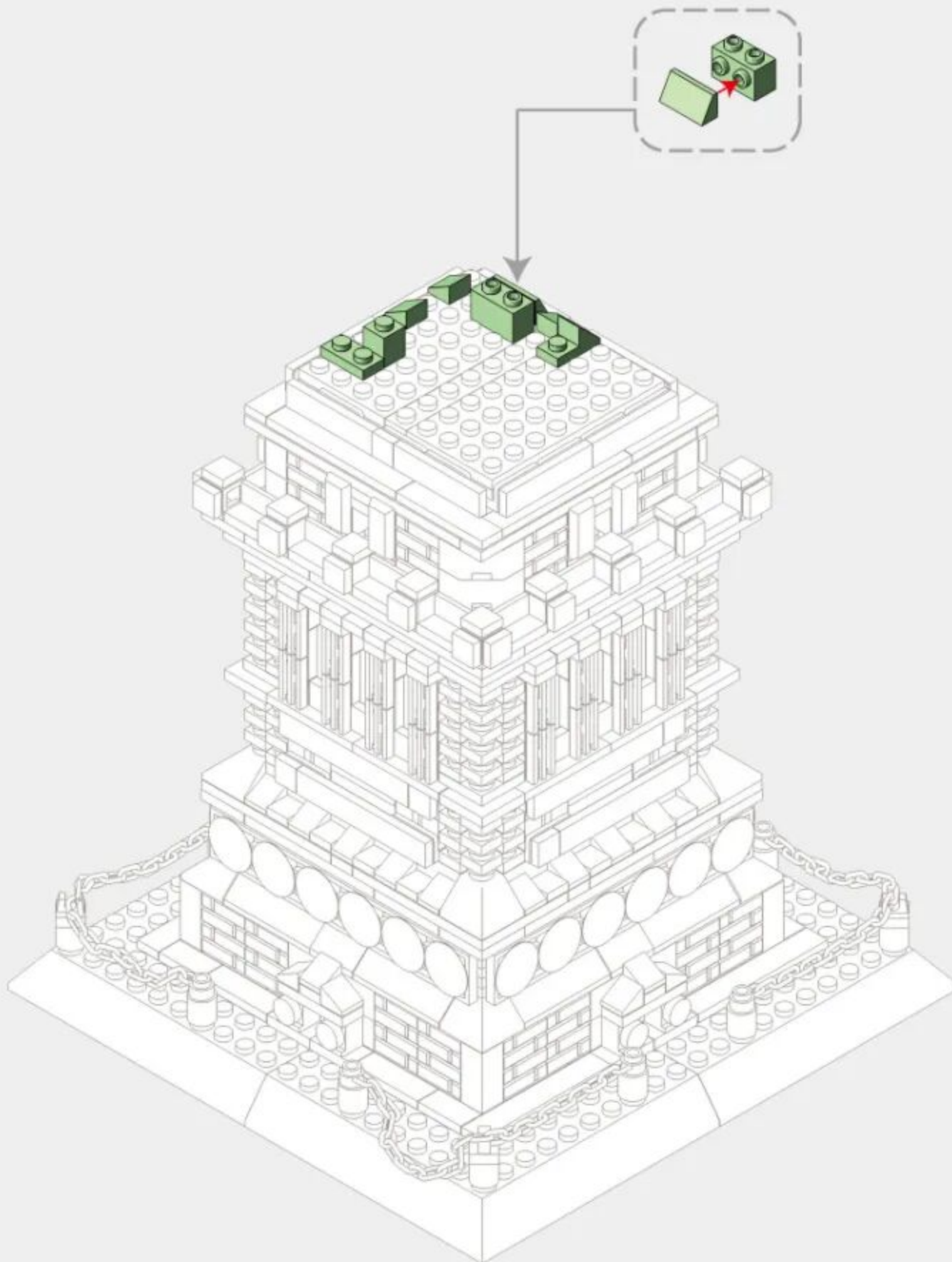

60



x1



x2



x1



x1



x1



x5

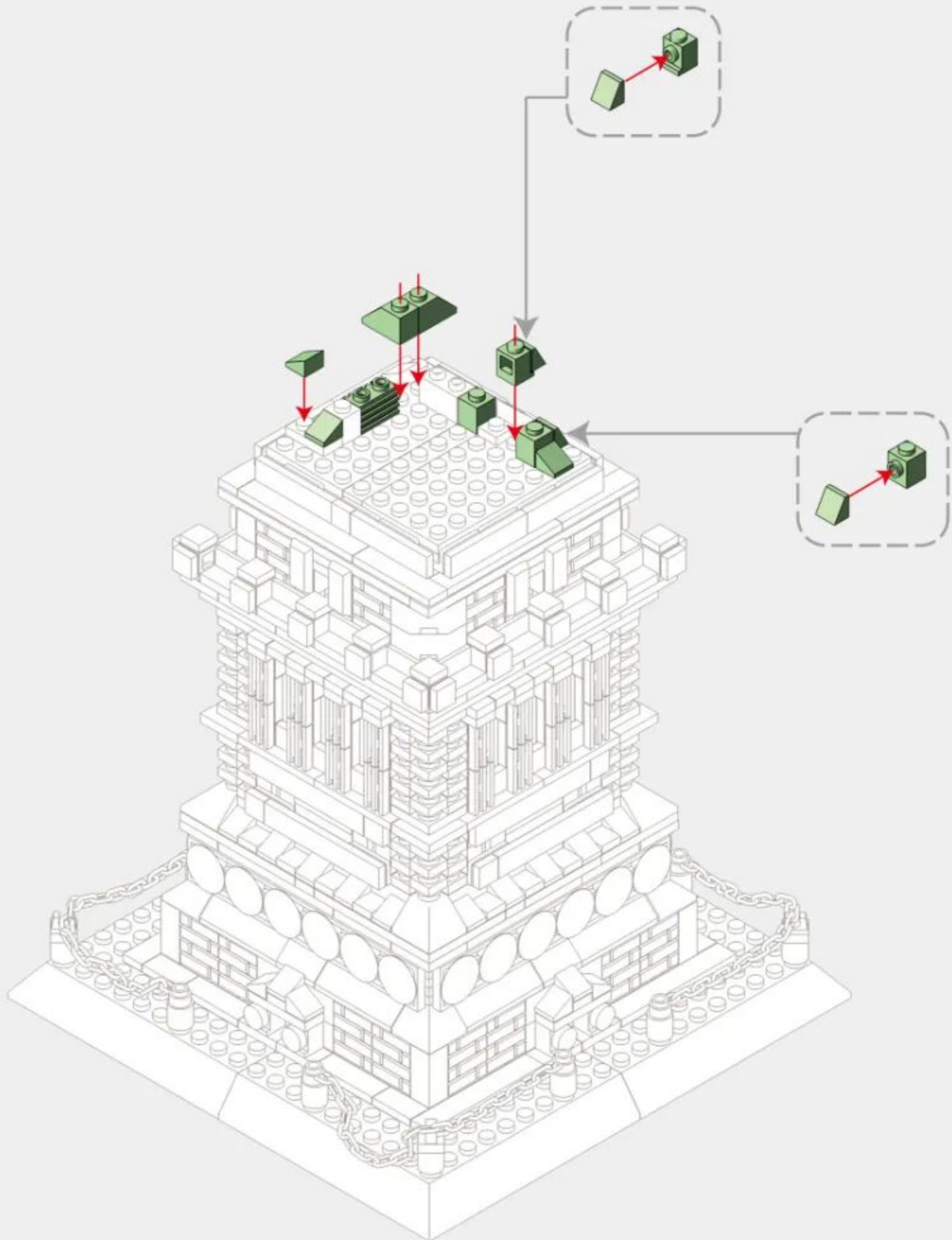

61



x2



x2



x1



x1



x1



x1



x1



x1

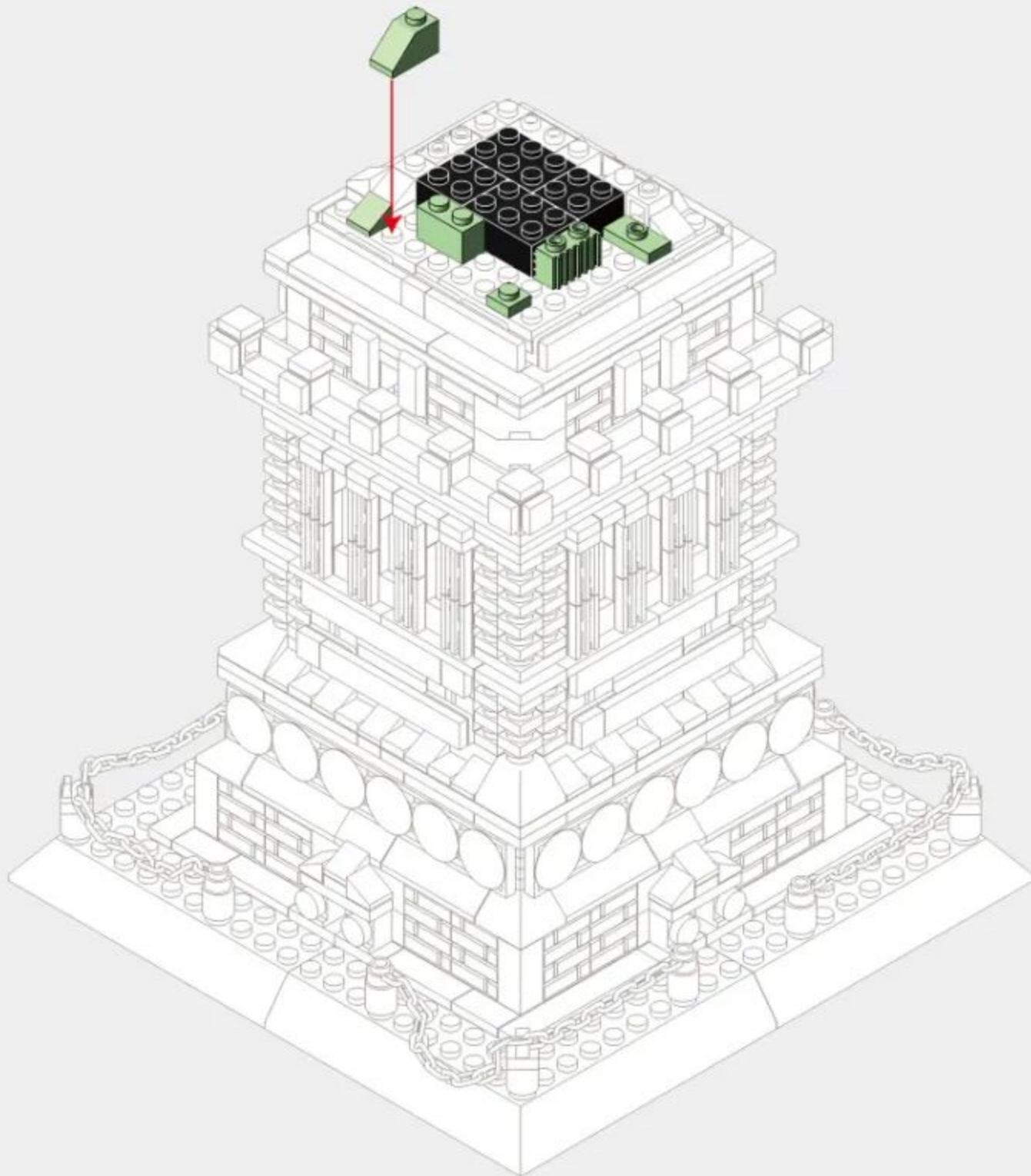

62



x2



x1



x1



x1



x3



x1

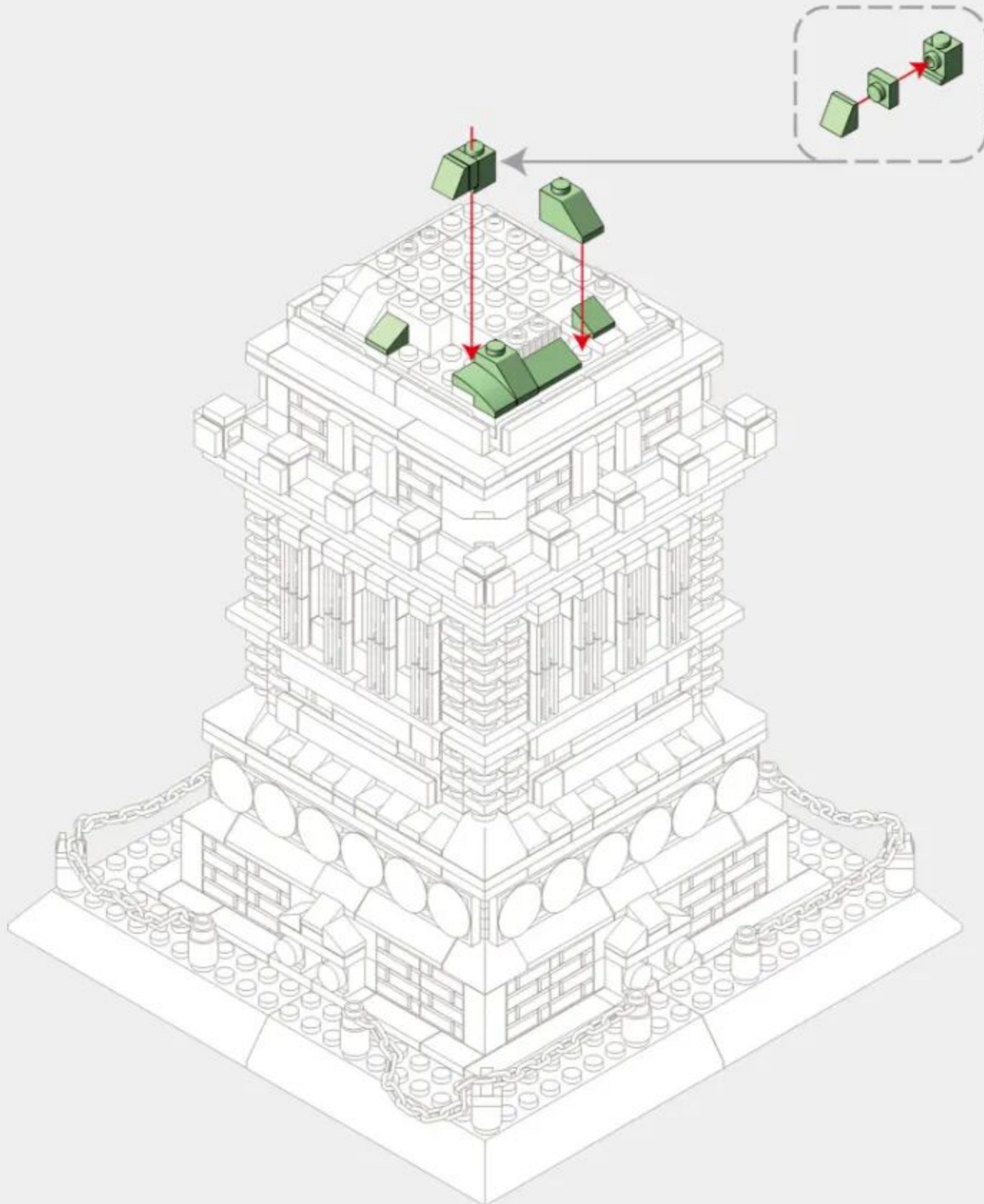

63



x2



x2



x4



x4



x4



x2

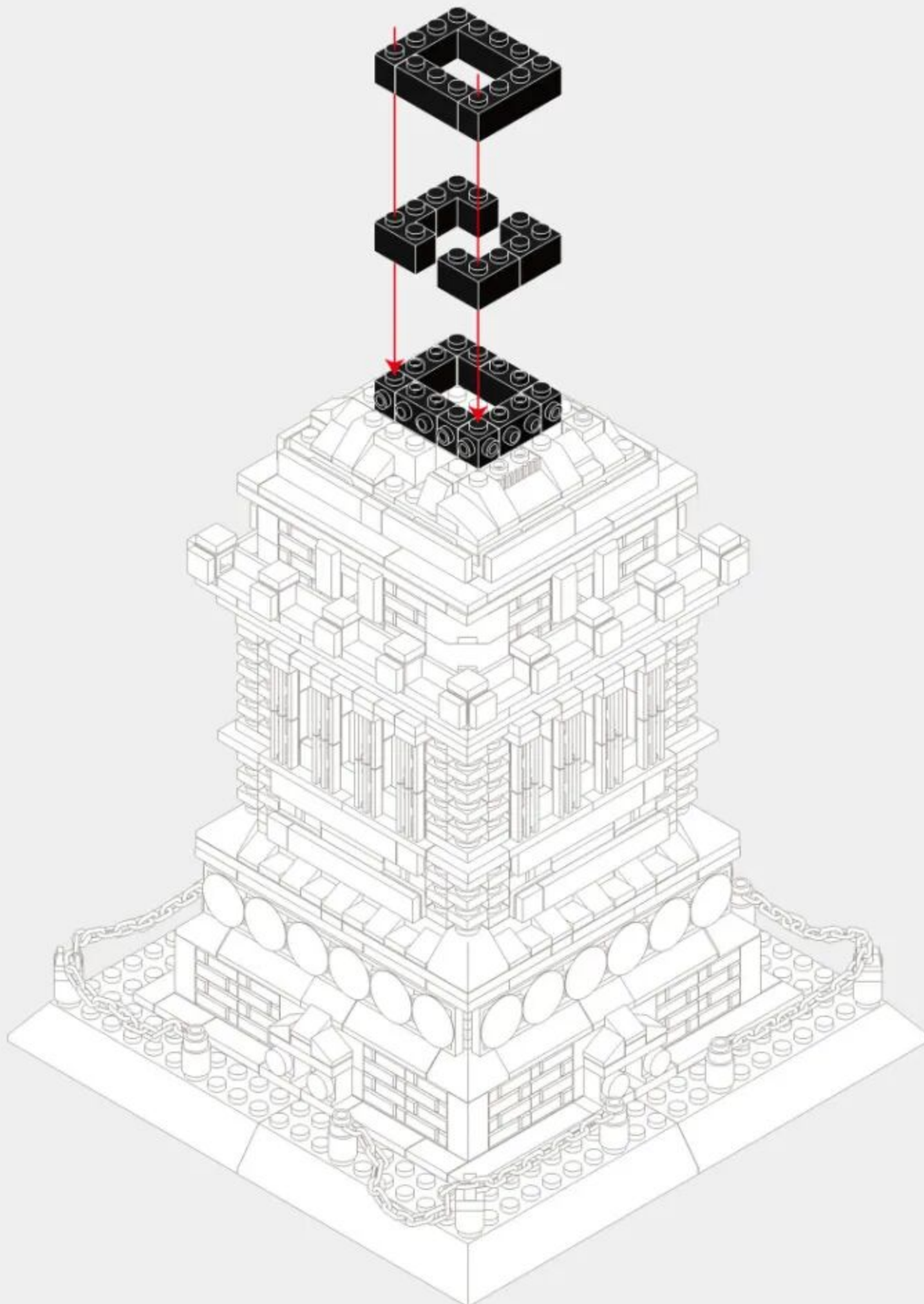

64



x1



x2



x4



x2



x6

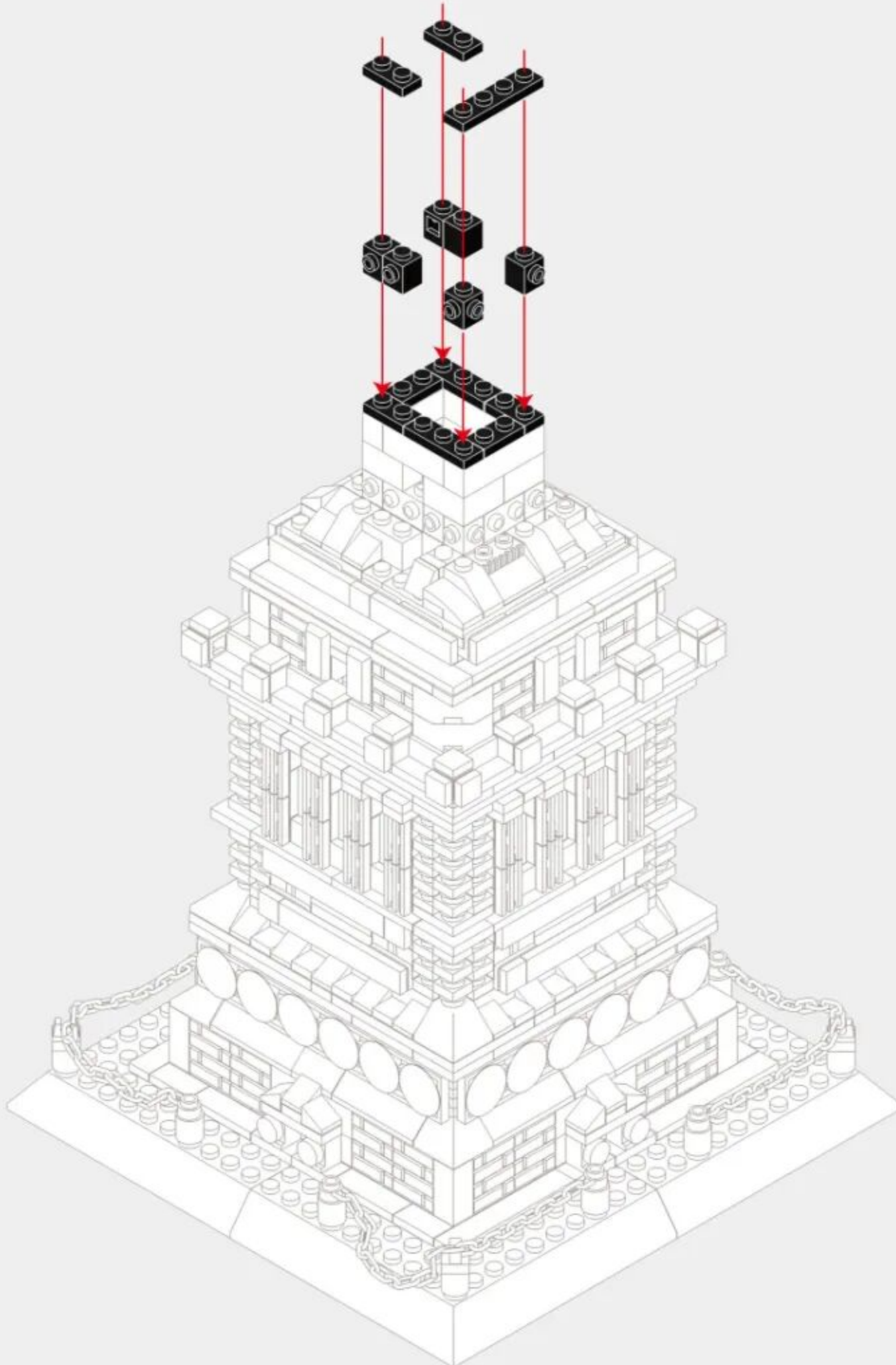

65



x4



x3



x4



x1

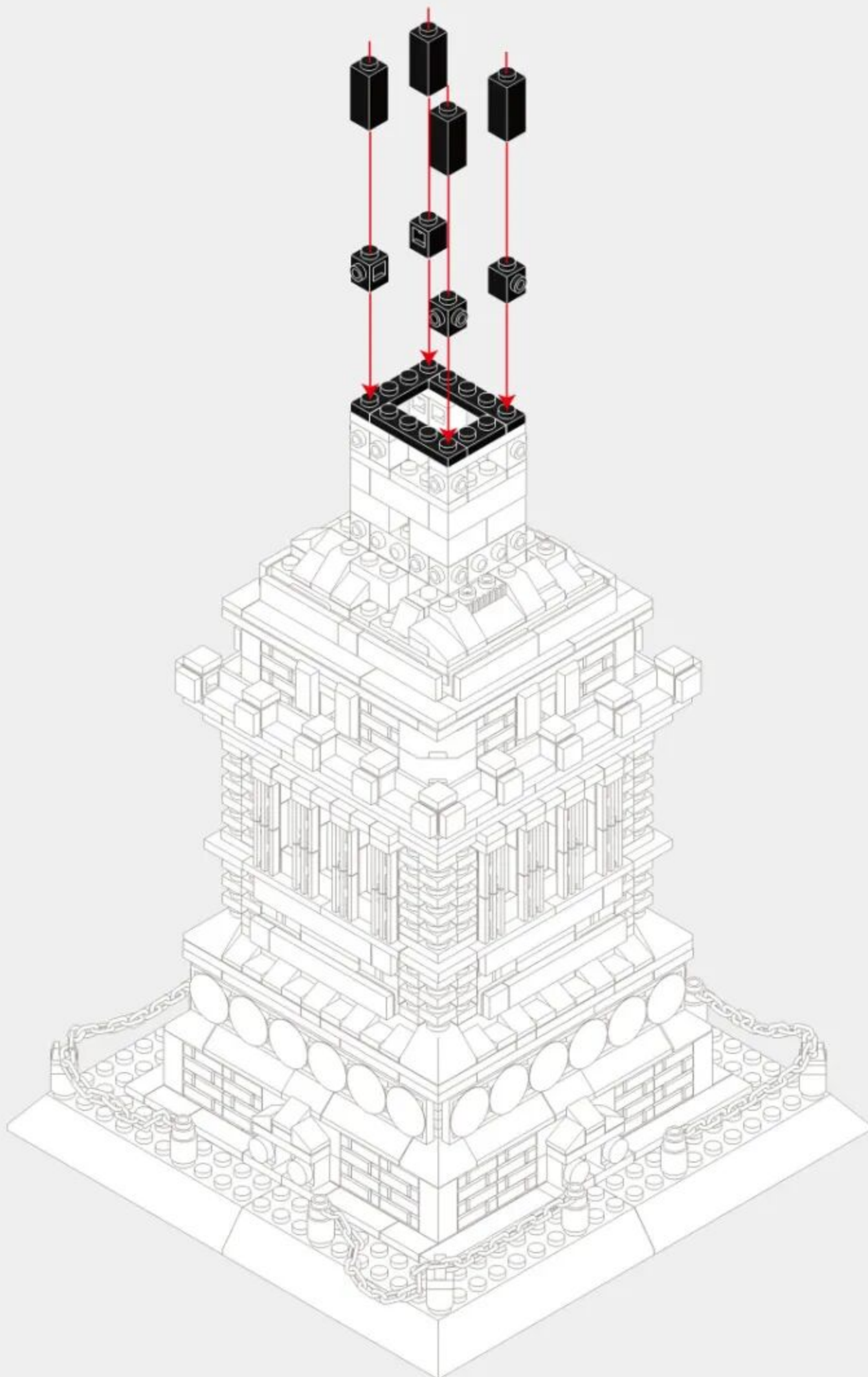

66



x2



x4



x2



x4



x2

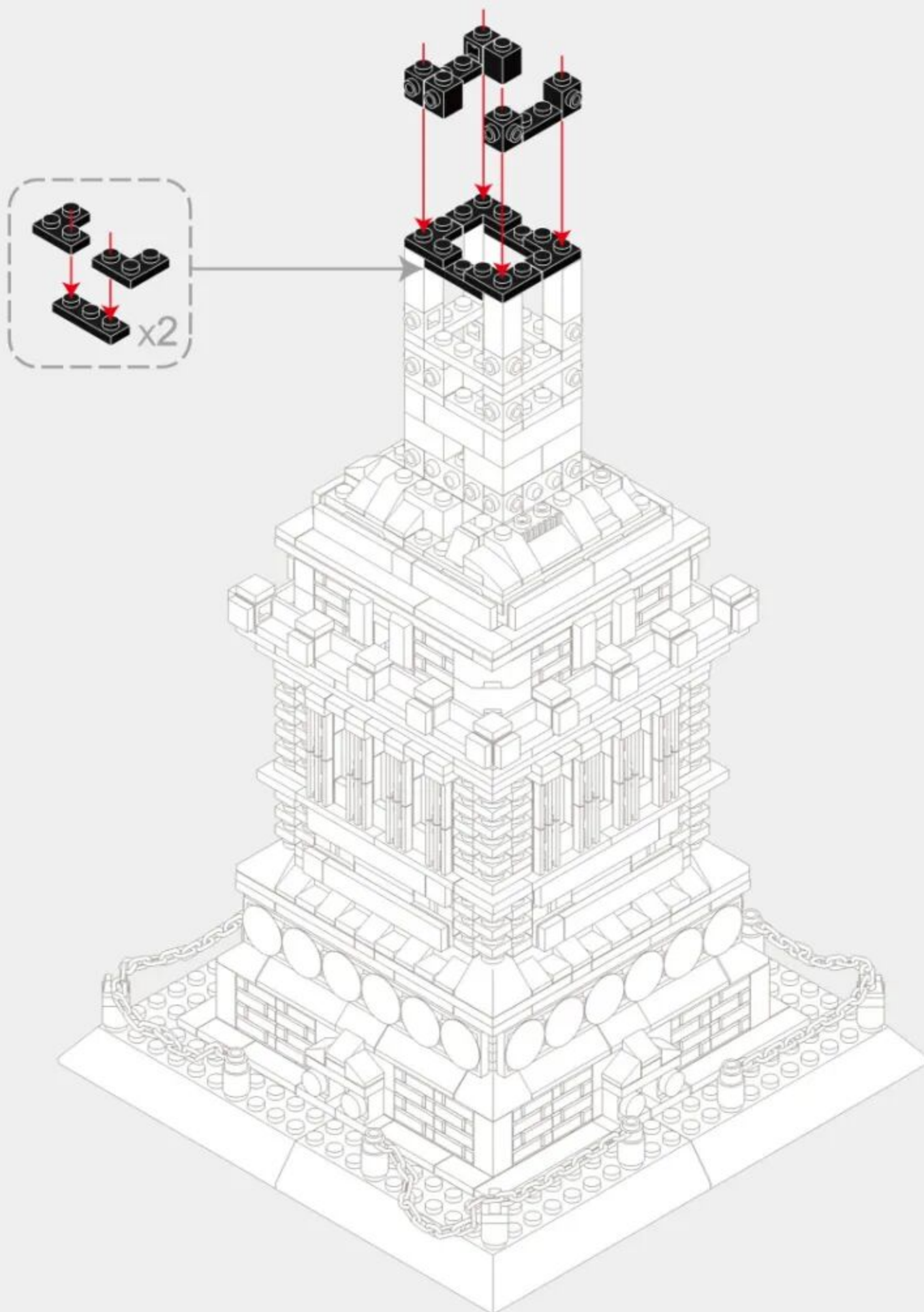

67

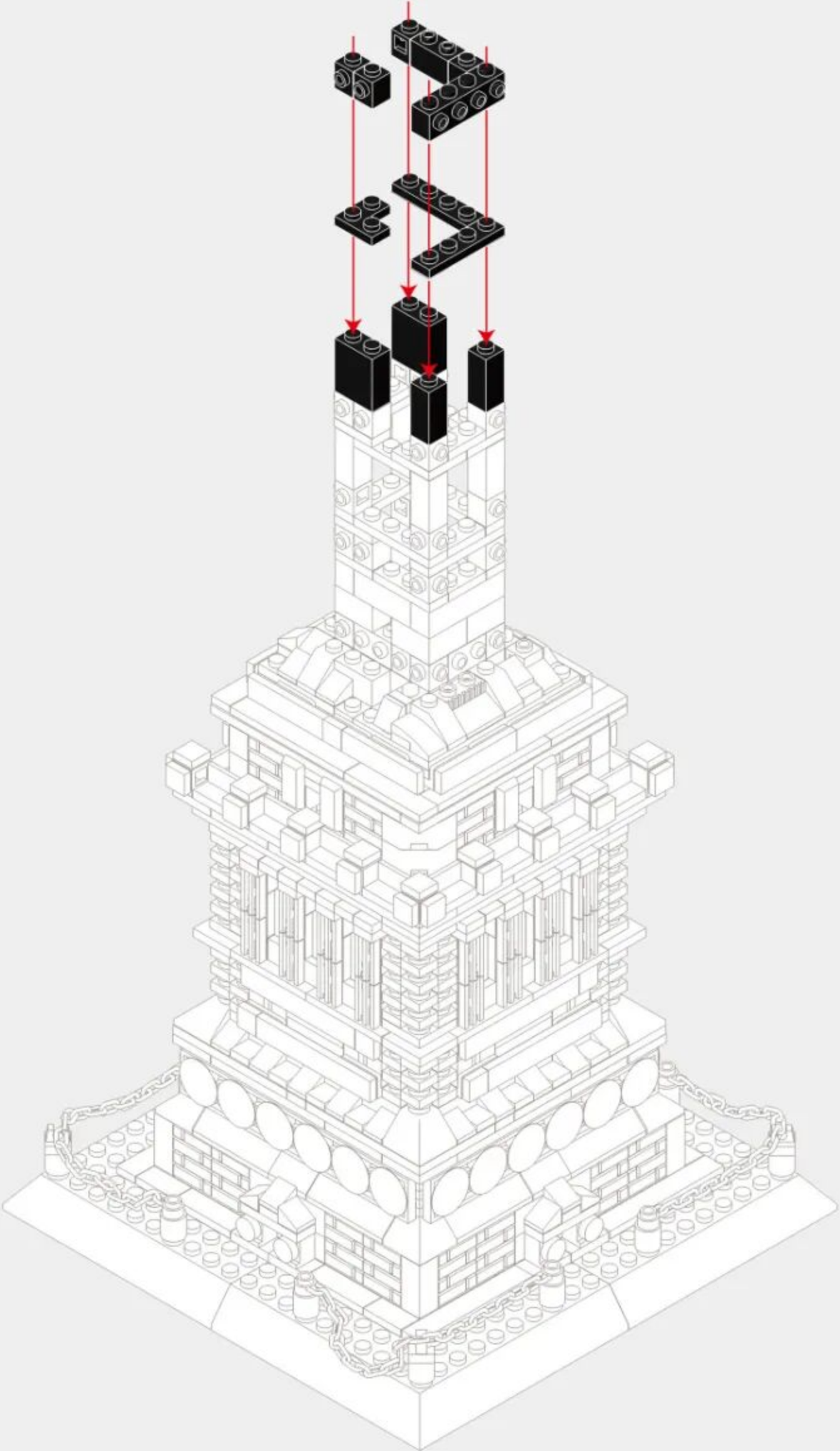
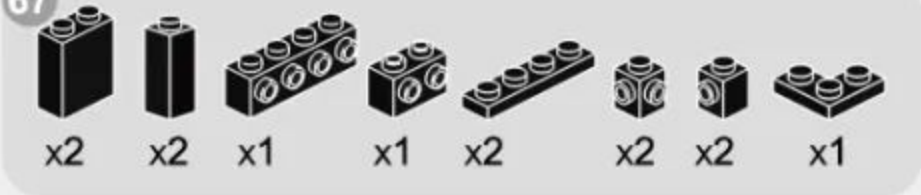

68



x1



x1



x6



x2



x2



x1



x2

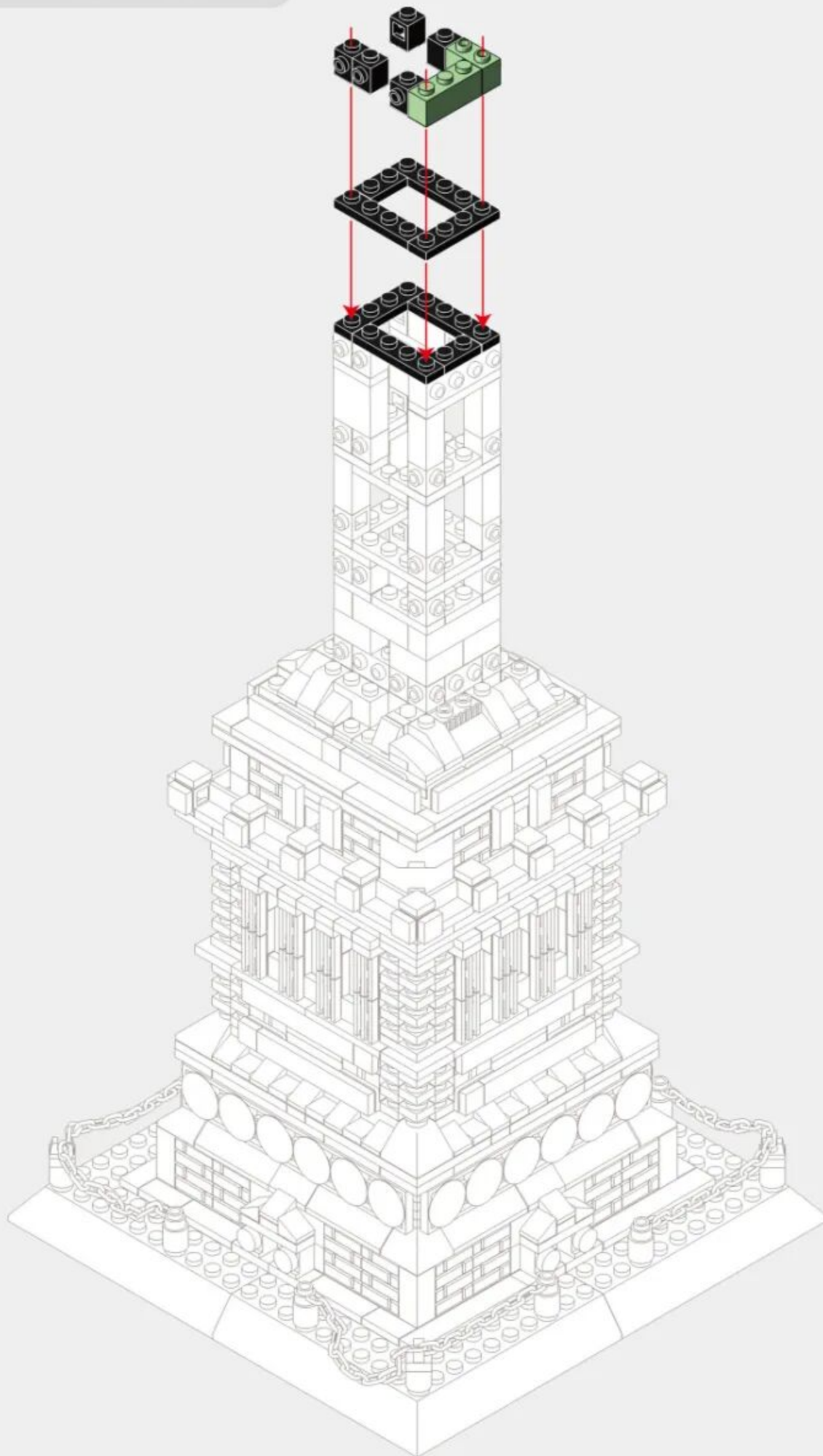

69

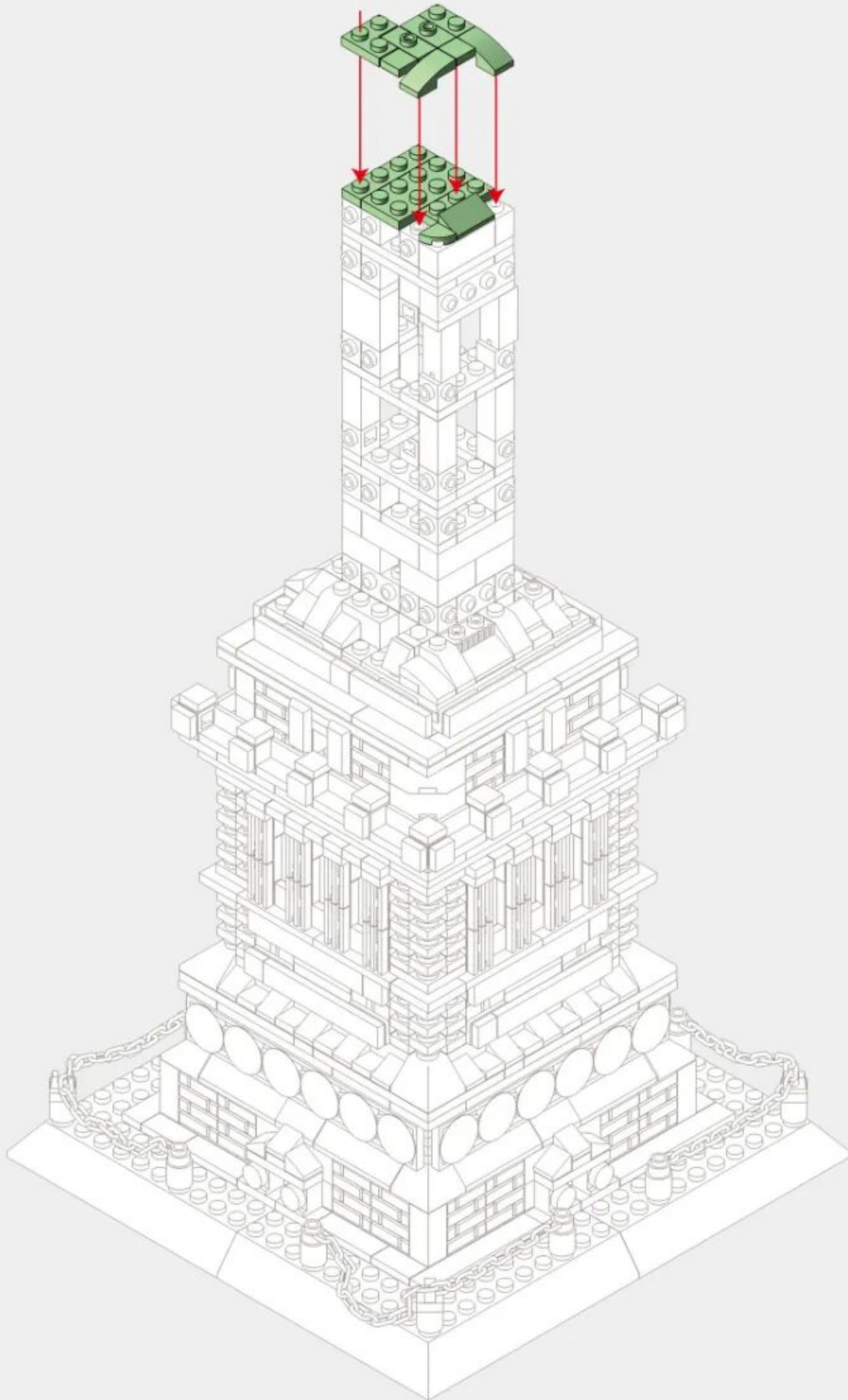
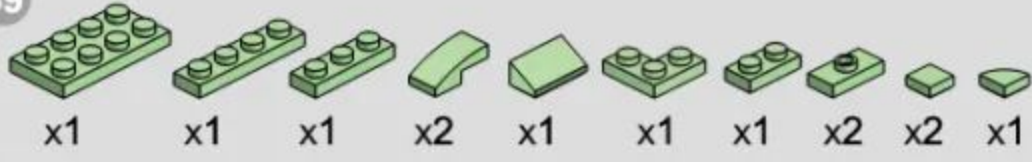

70

4 X 12

1 X 10

1 X 8

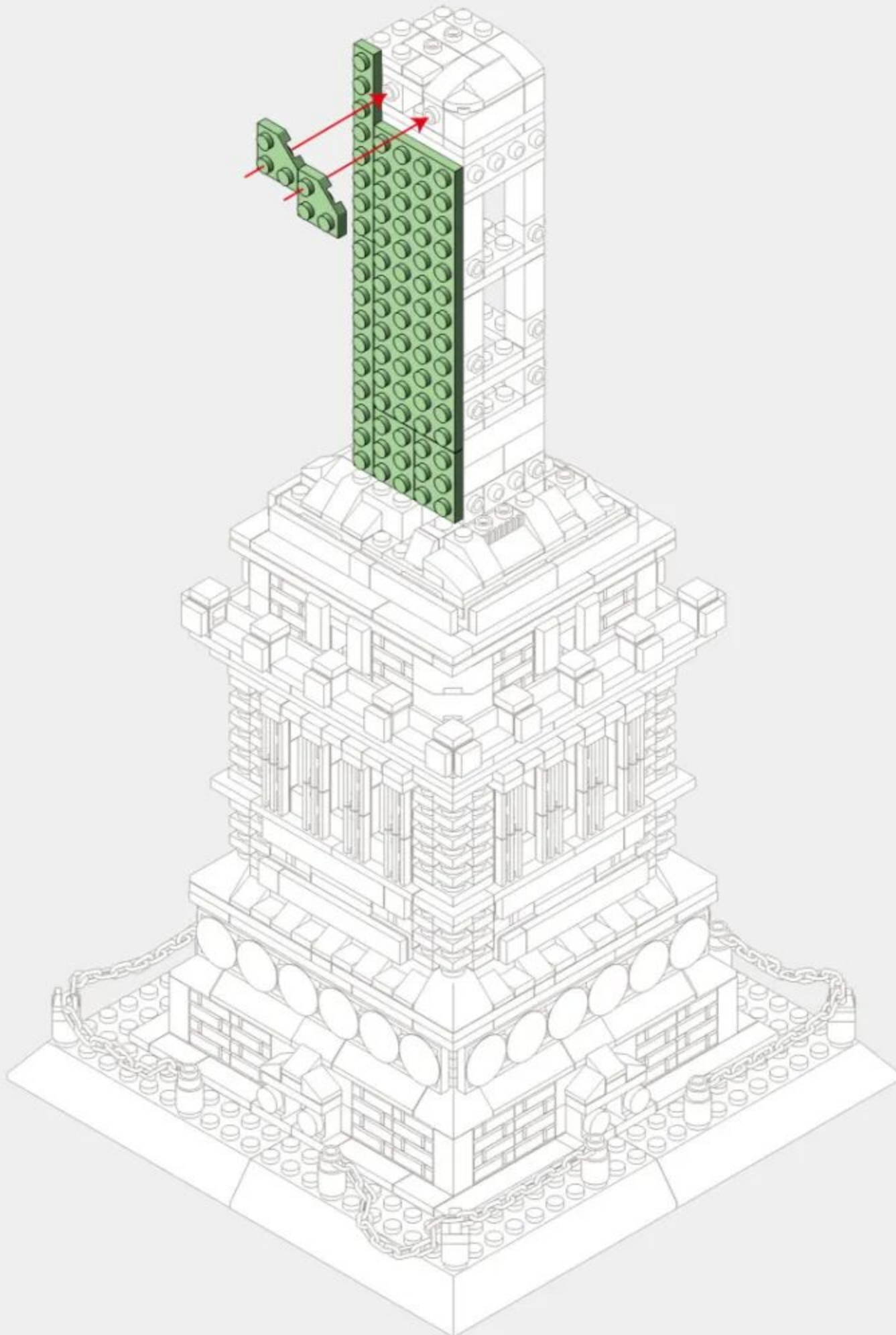
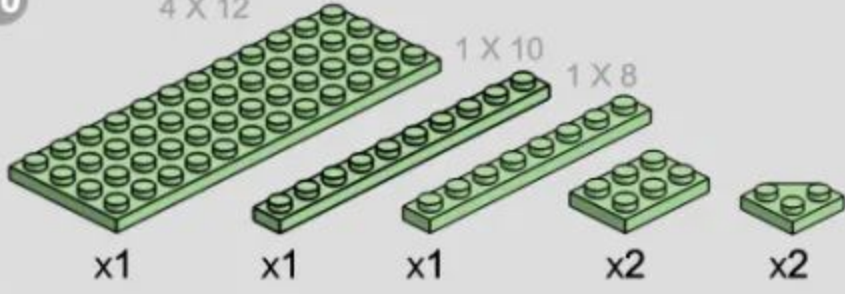

71

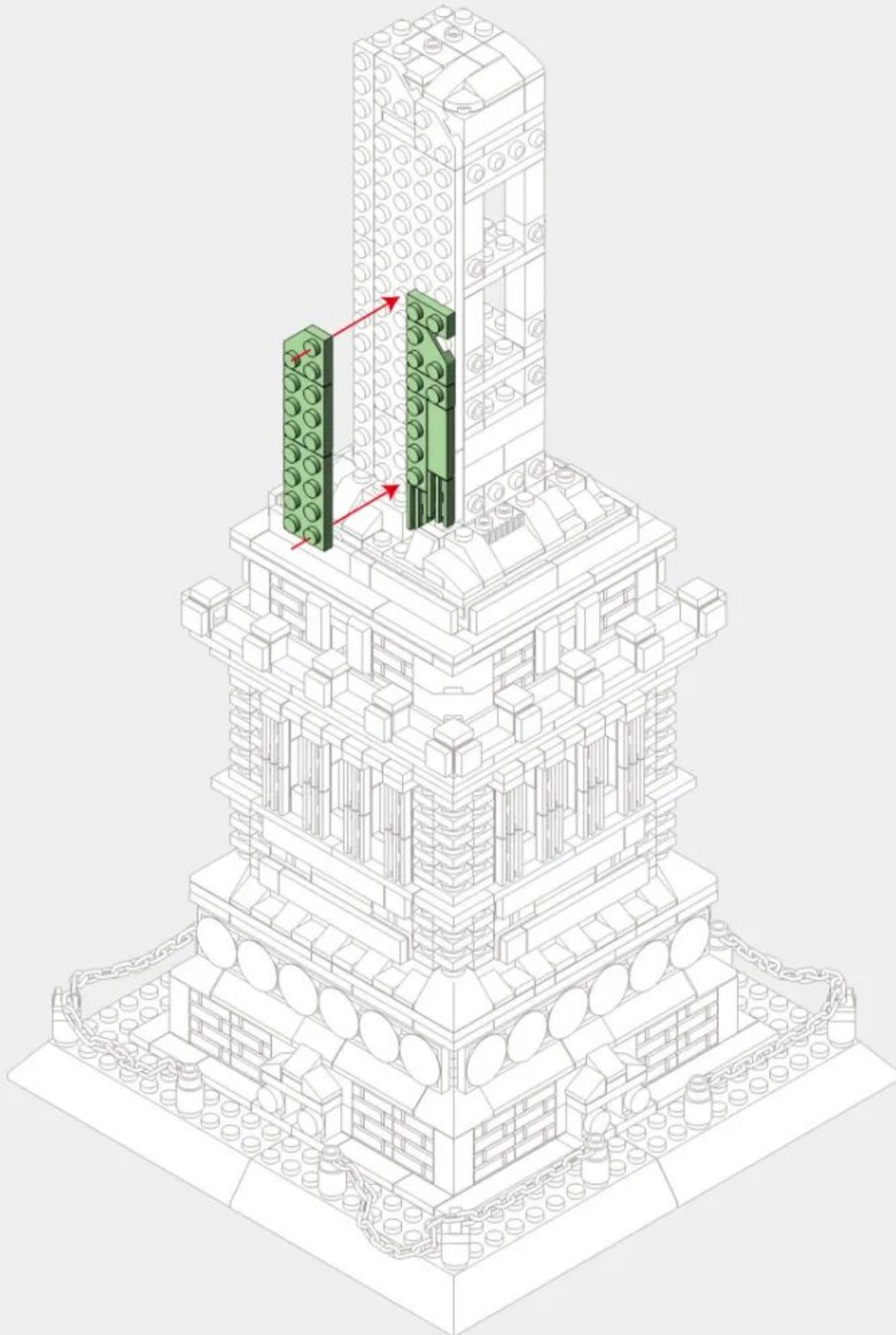
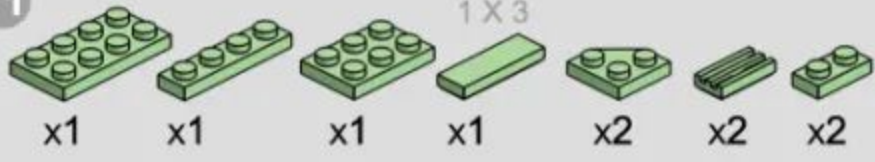

72



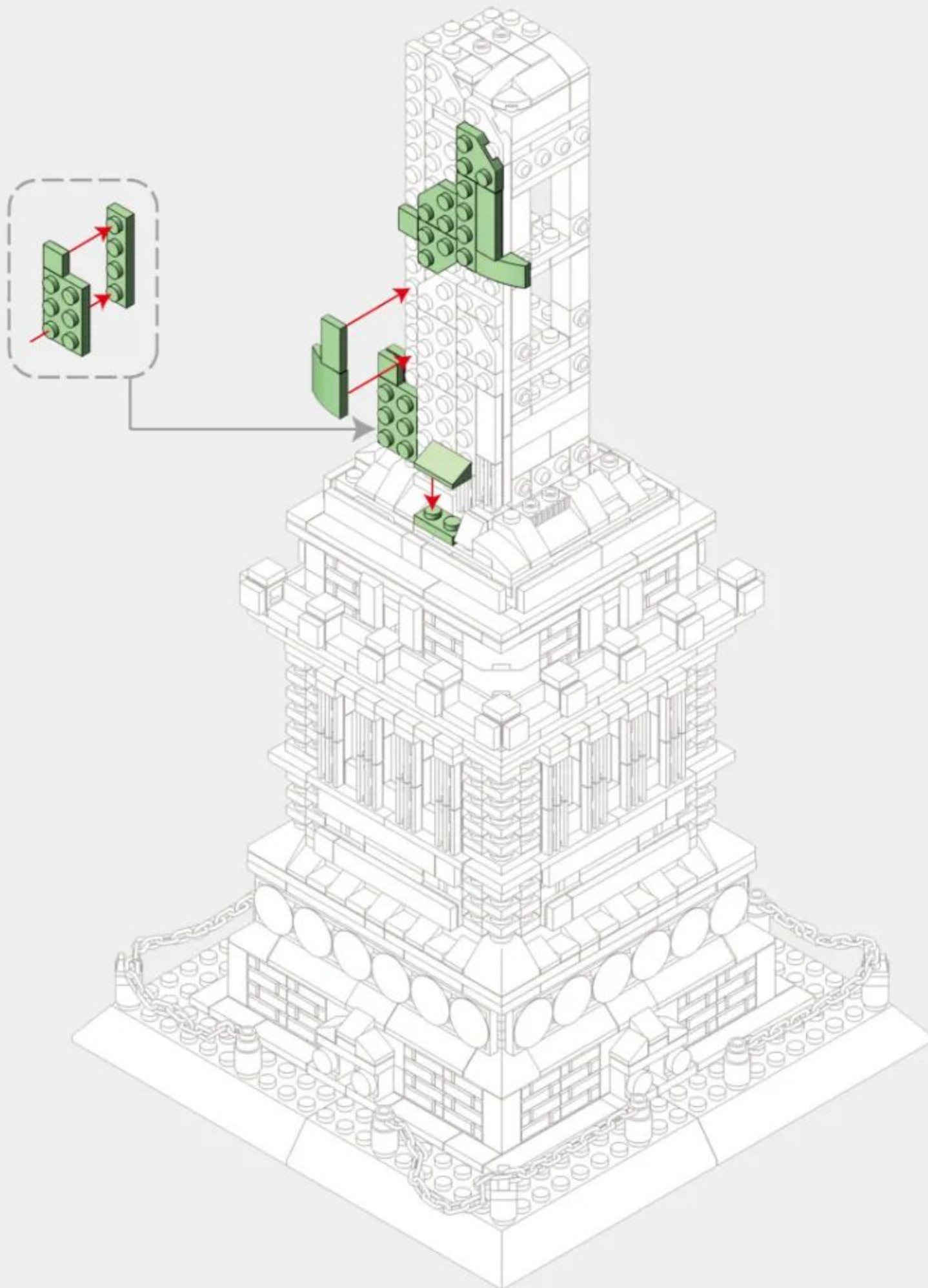

- x2
- x1
- x1
- 1 X 3
- x1
- x1
- x3
- x1
- x1
- x2



73 1 X 4

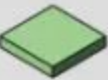

74

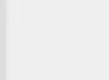
-  x1
-  x1
-  x3
-  x3
-  x2
-  x2
-  x2

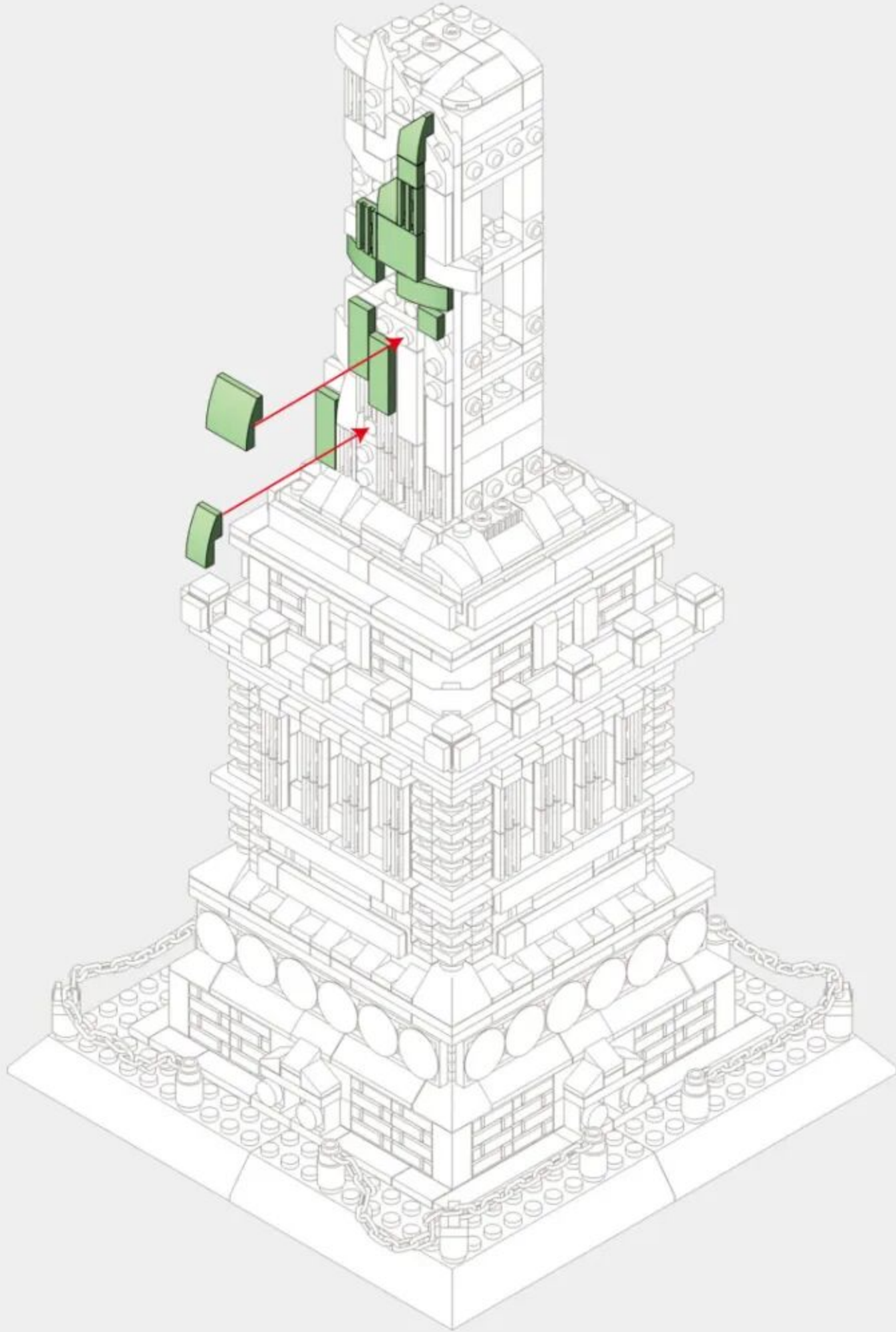

75

4 X 12

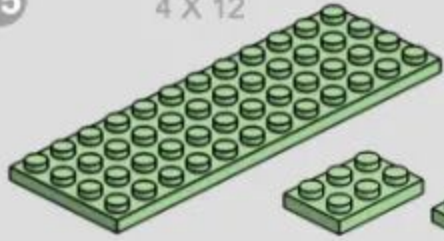

x1



x2



x1



x1



x1



x1



x3



x1

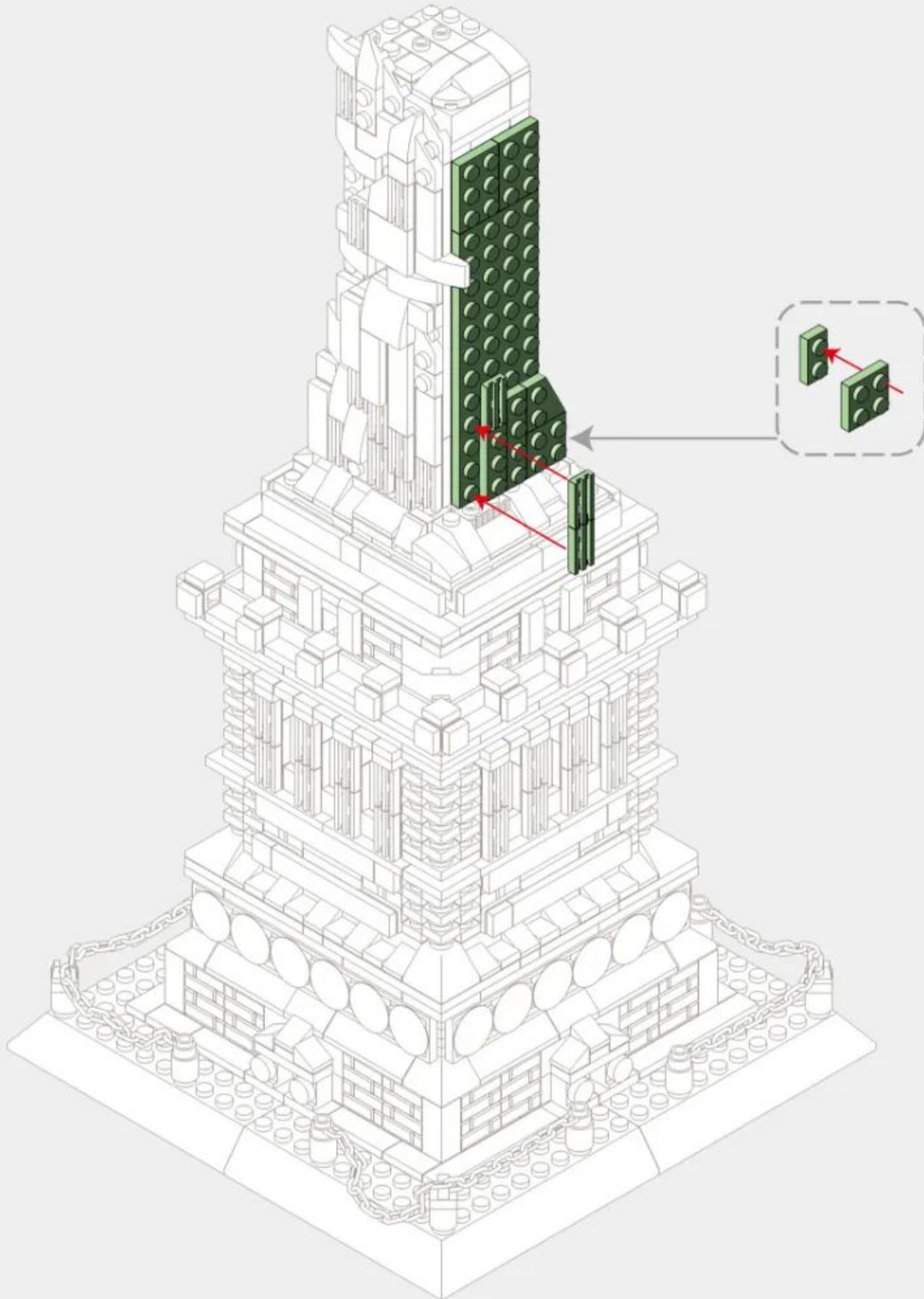

76

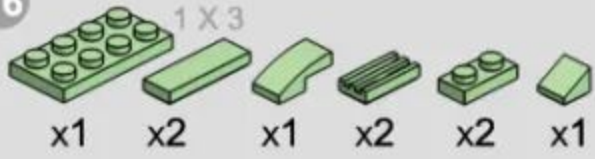

77

- x1
- x1
- x2
- x1
- x1
- x2
- x2
- x1
- x1
- x1



78



79

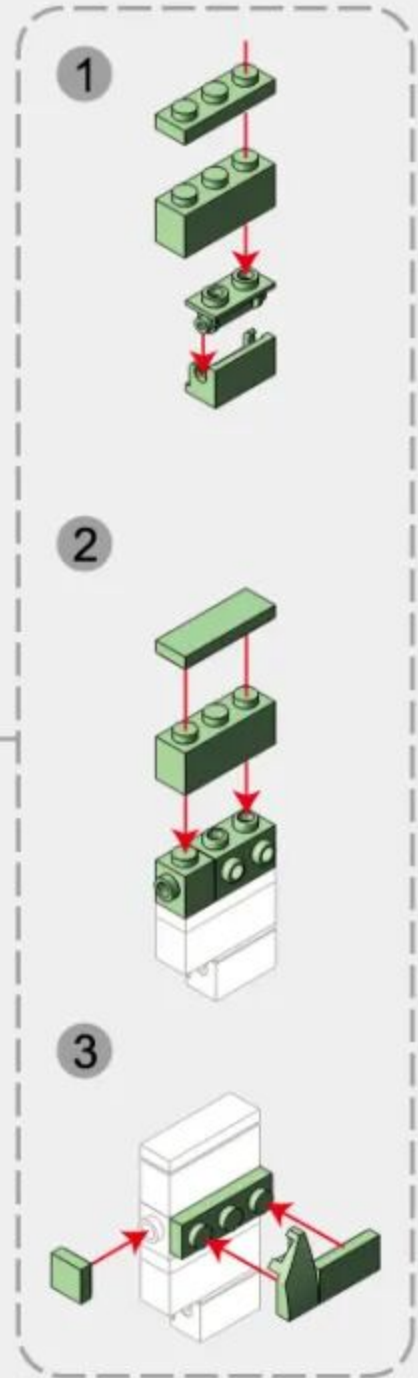
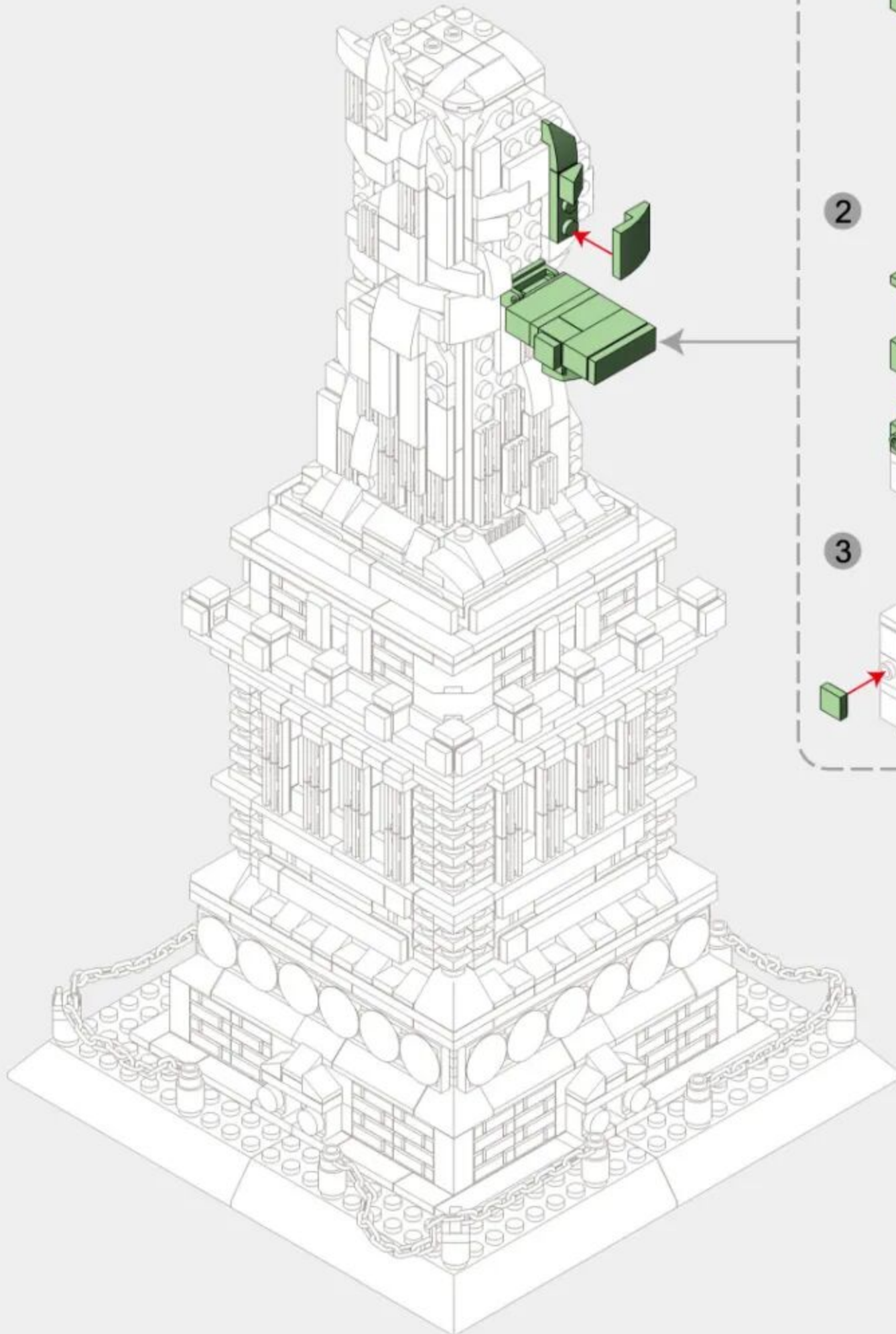
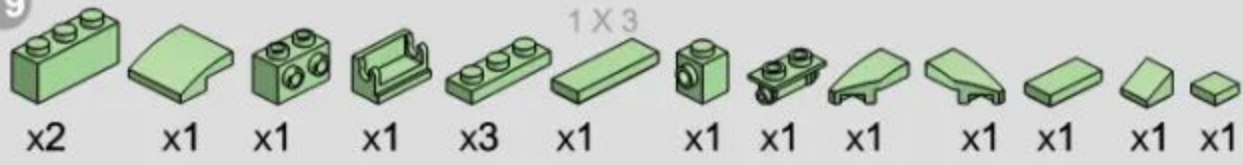

80

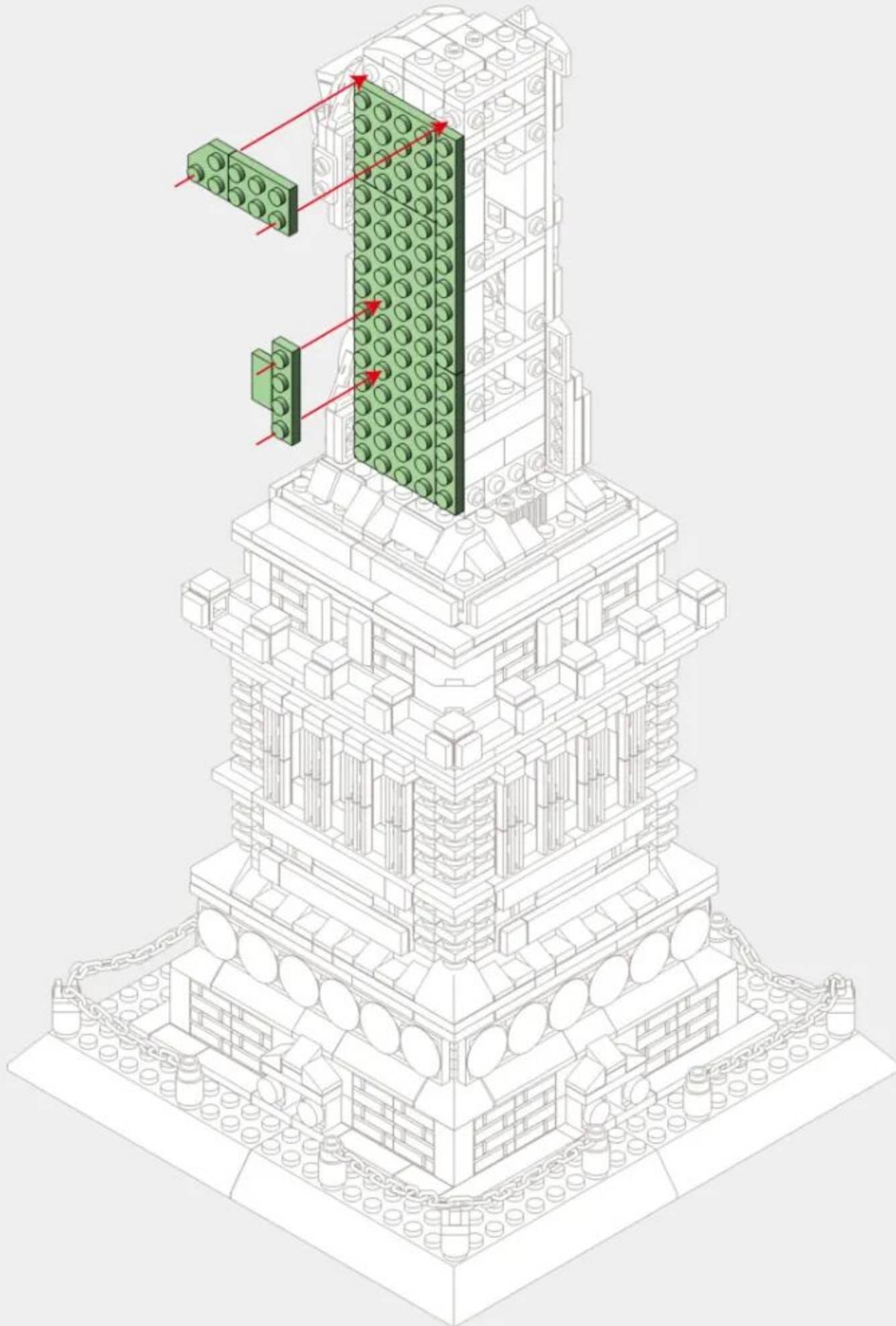
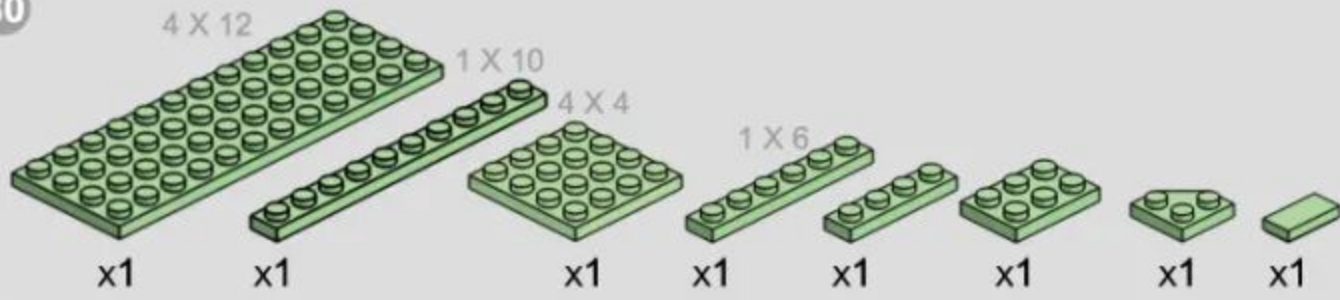

81

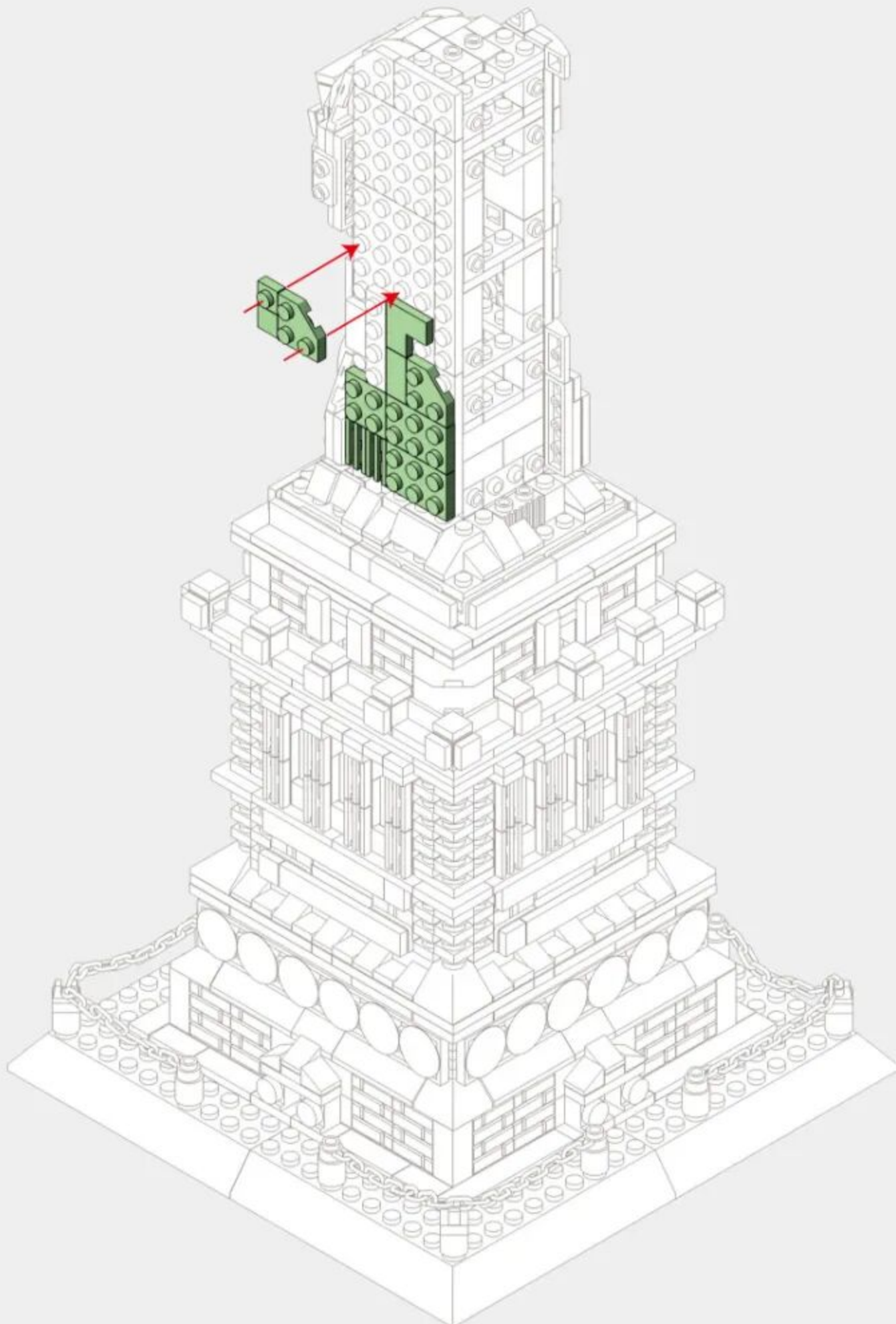

82

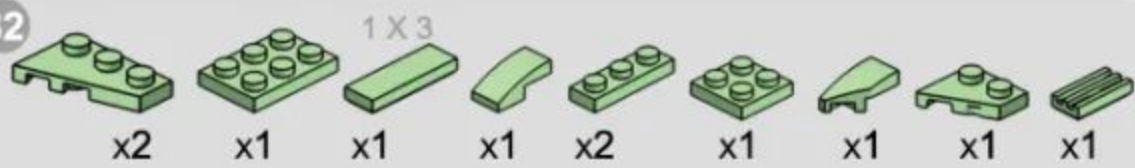

83

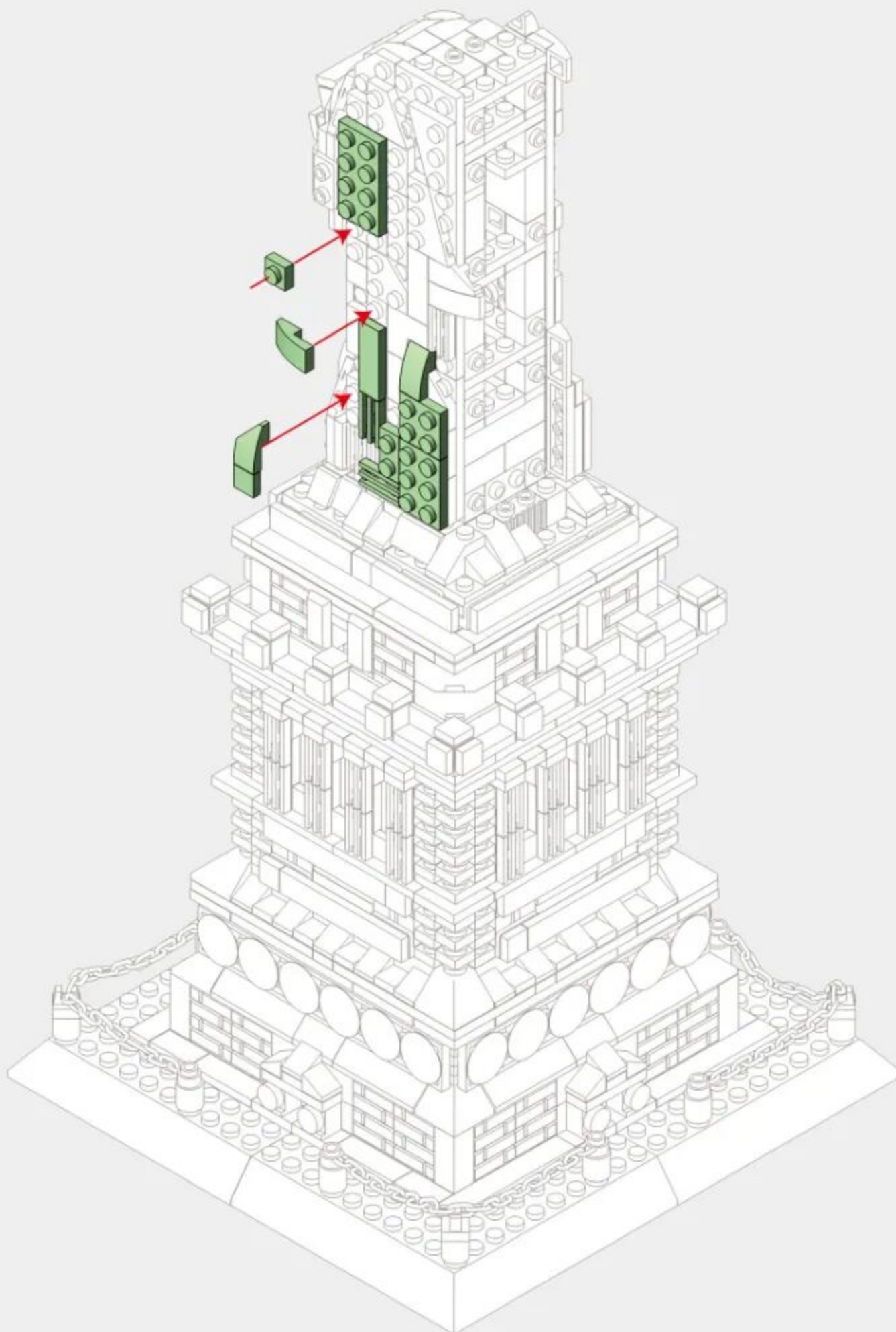
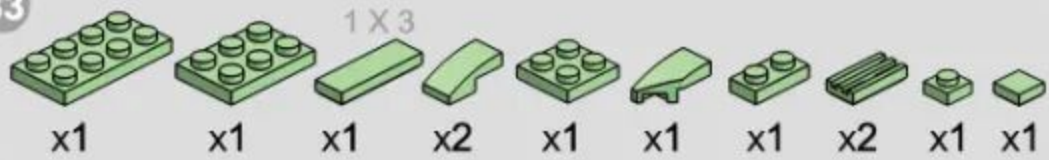

84 1 X 4



x1



x2



x3



x2



x1



x2



x1



85

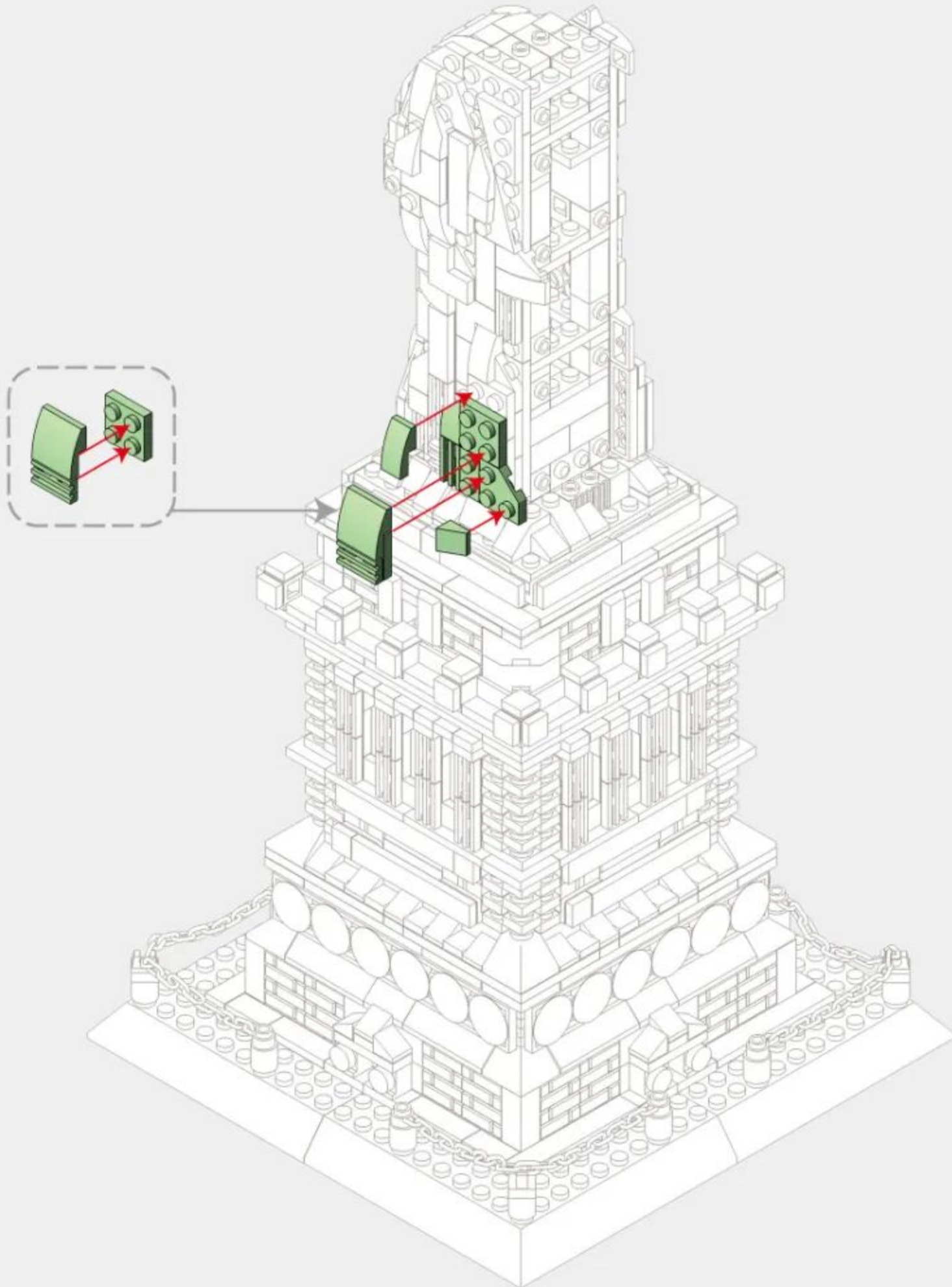
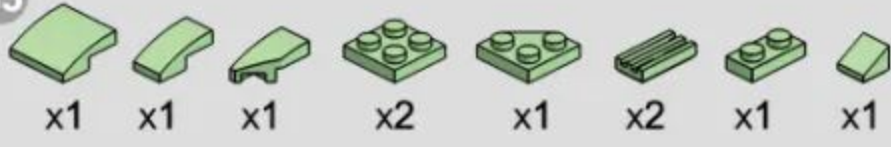

86

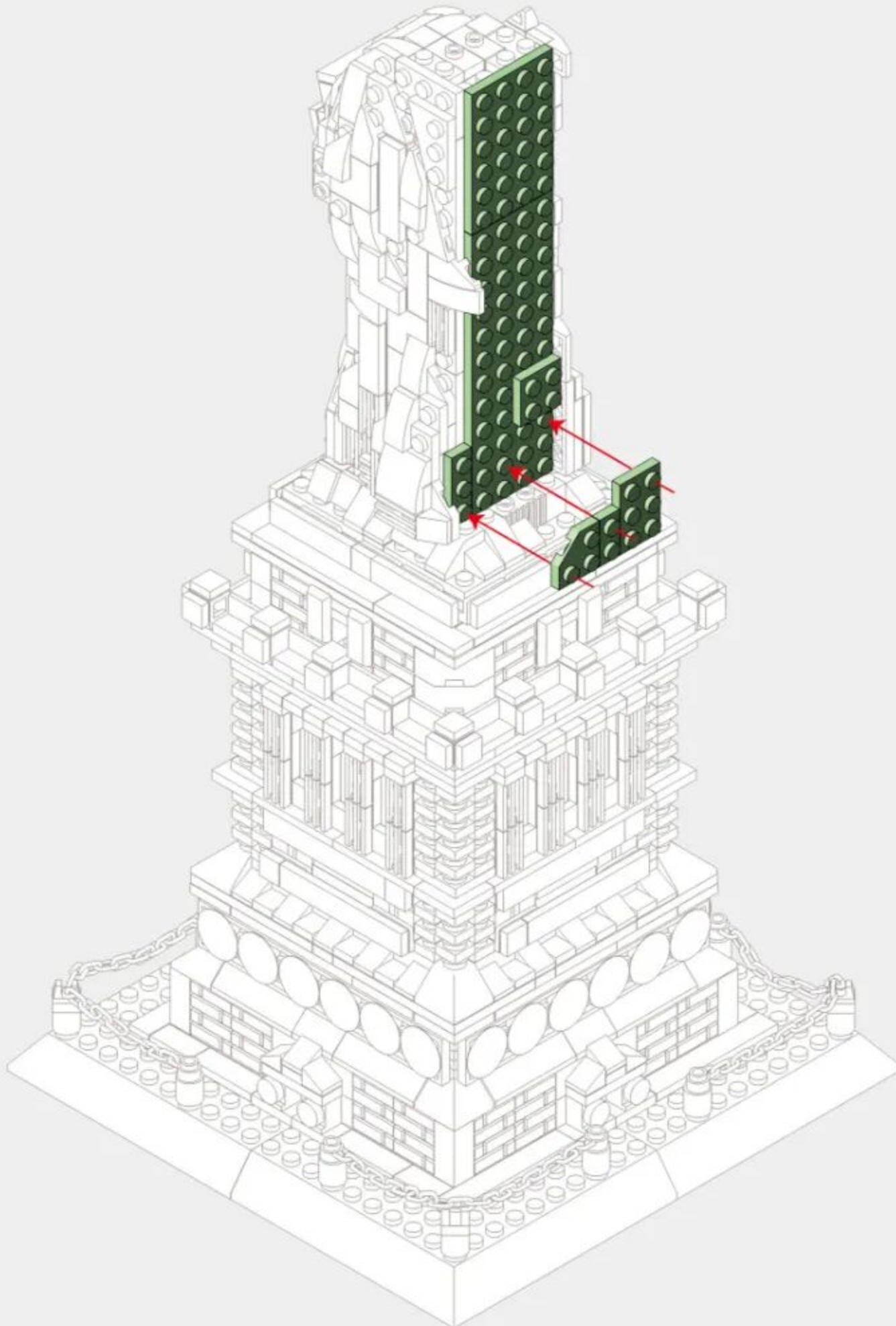
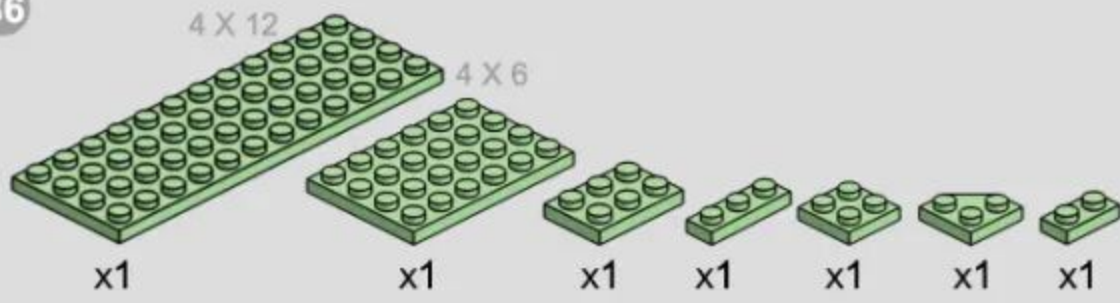

87

1 X 3



x1



x1



x1



x2



x2



x1



x1



88

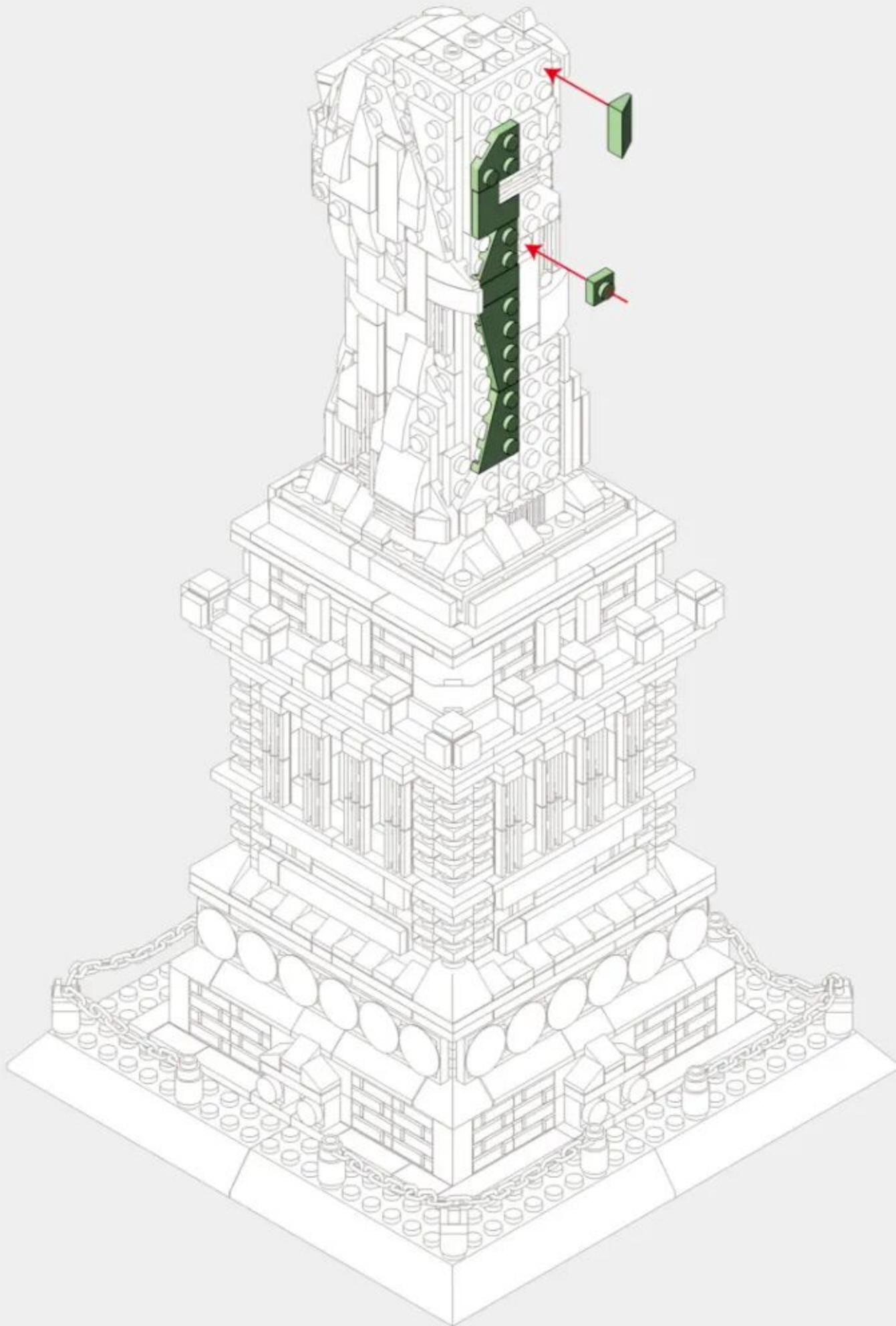
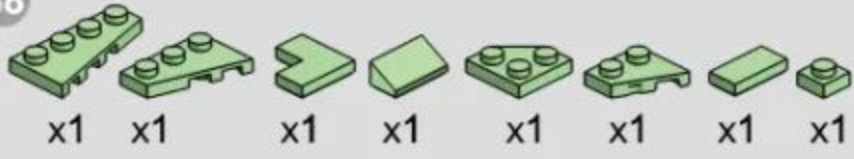

89

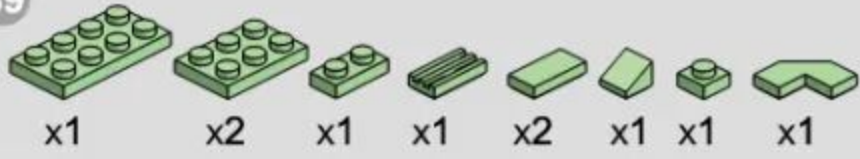

90

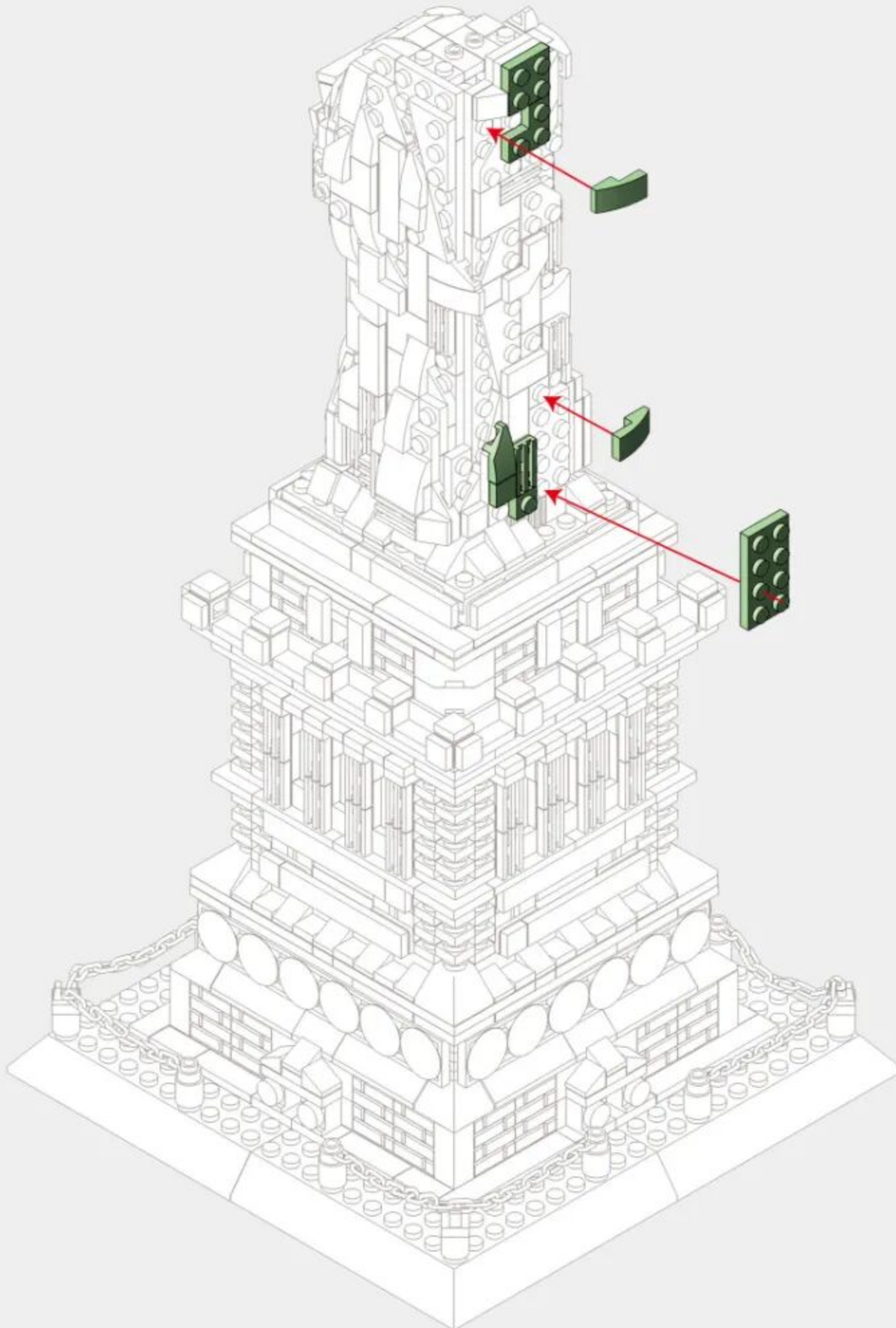
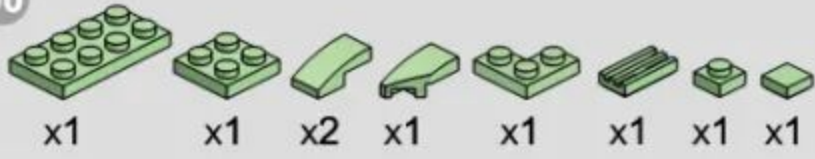

91



x3



x1



x2



x1



x1



x2

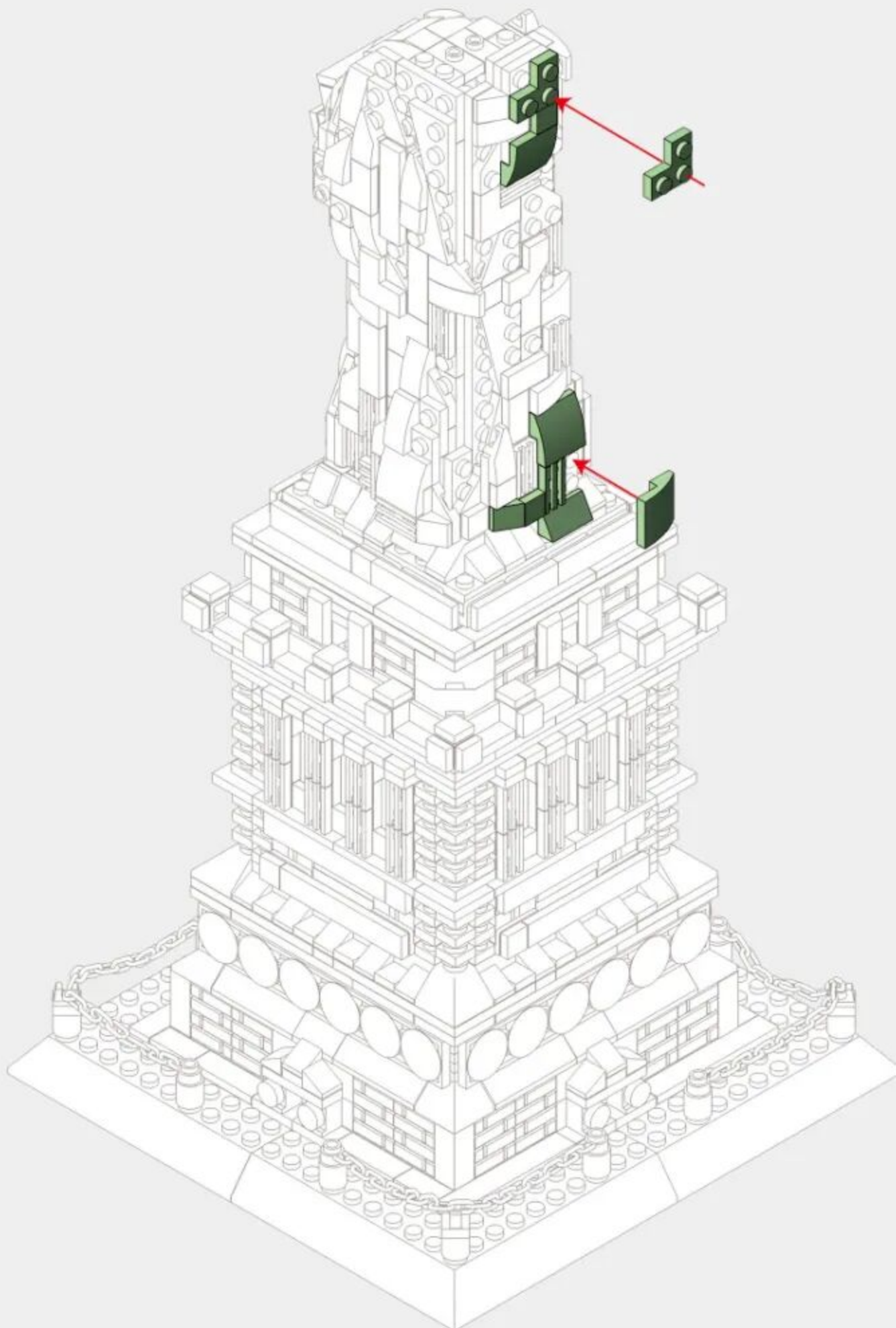

92



x1



x2



x1



x1



x1

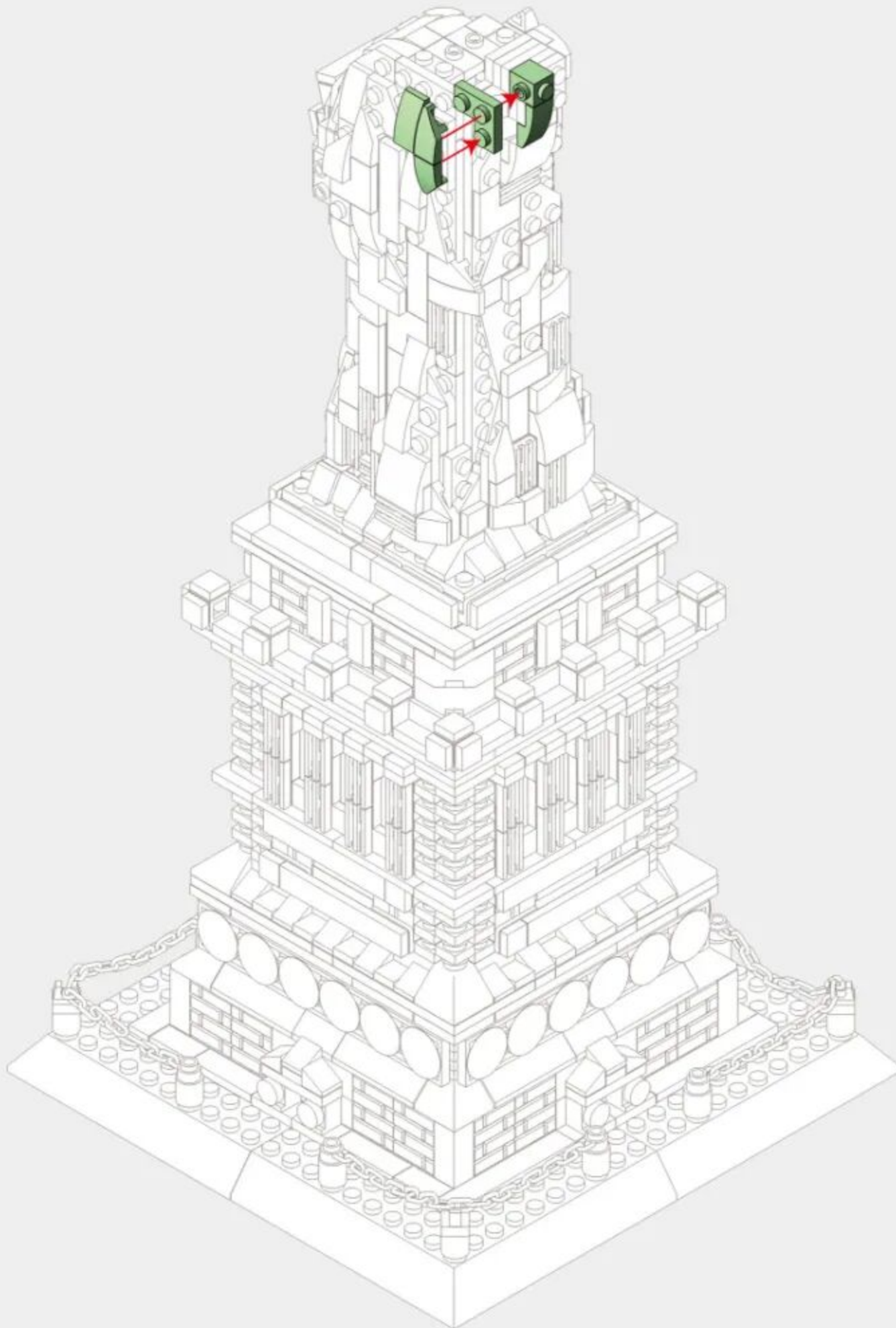

93

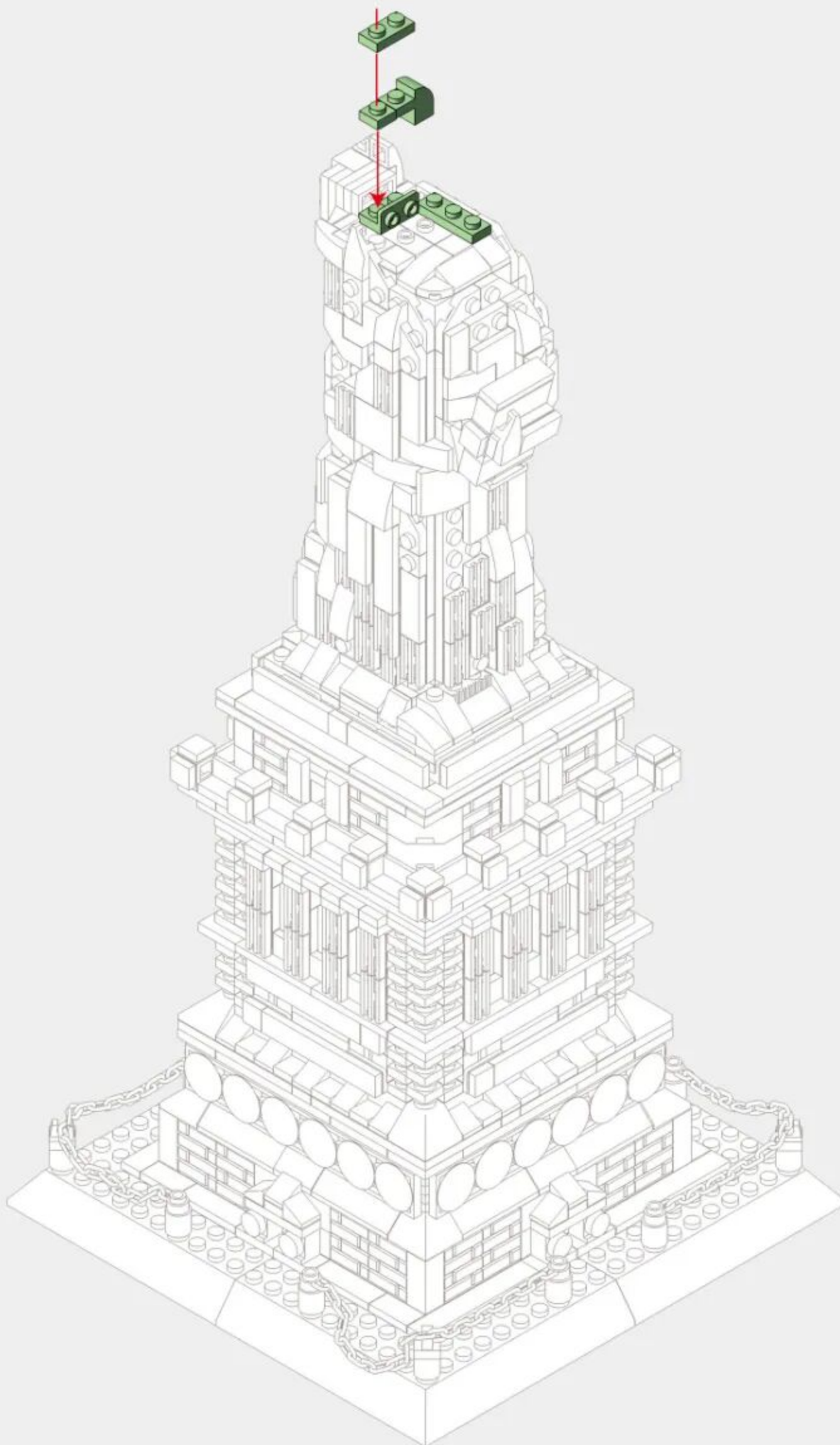

94

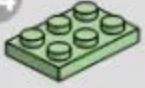

x1



x1



x1



x2



x1

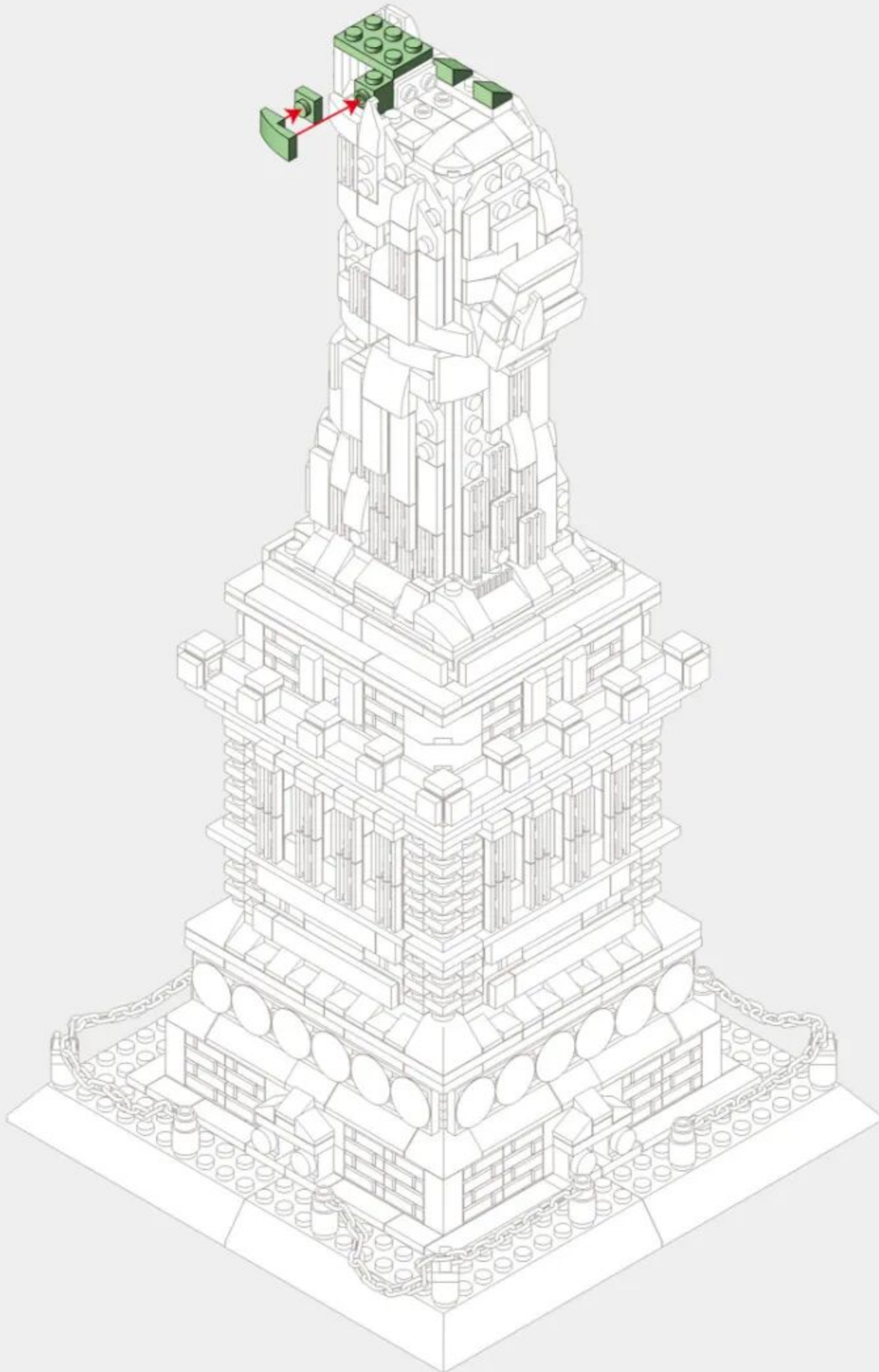

95



x1



x1



x1



x1



96

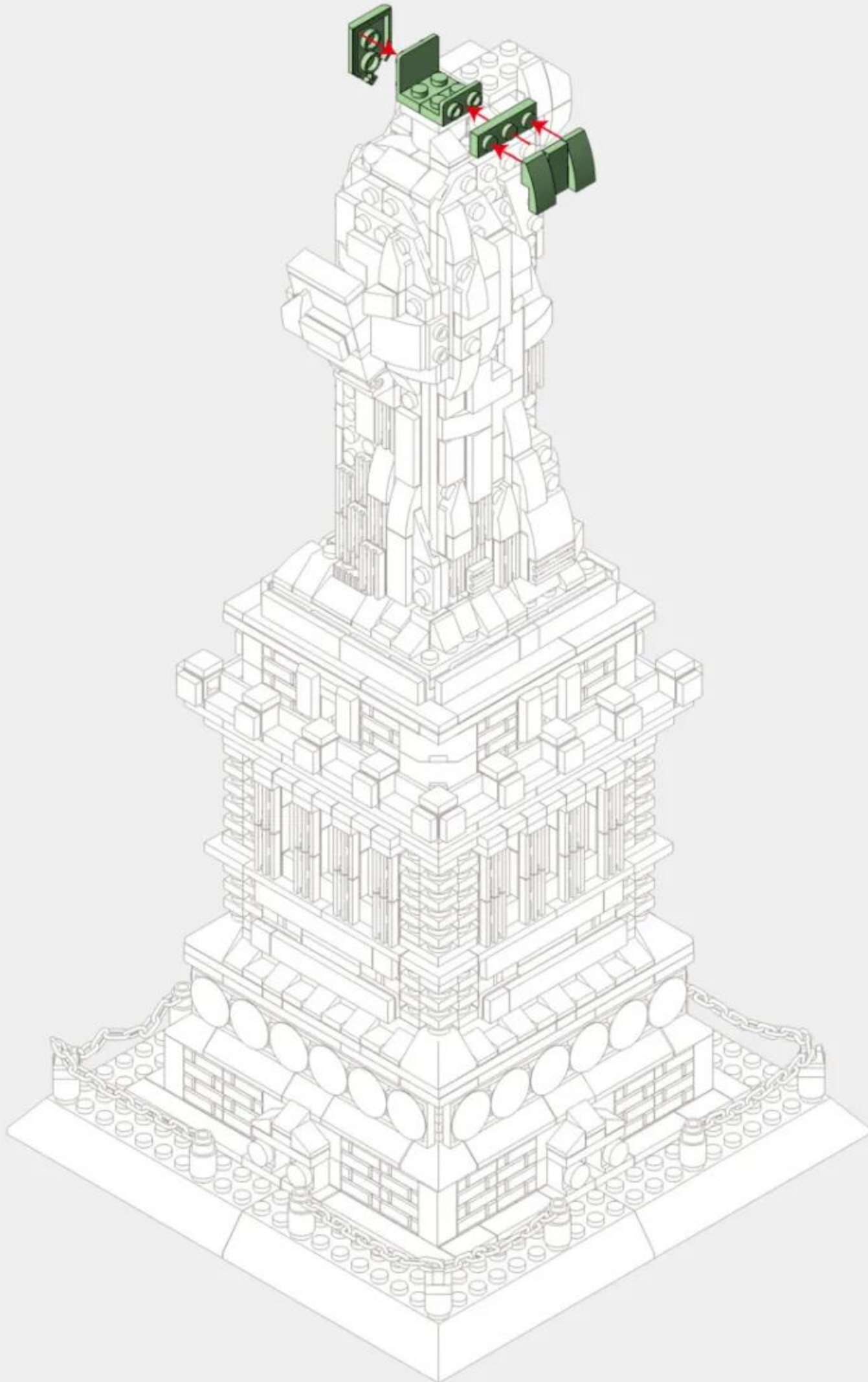

97

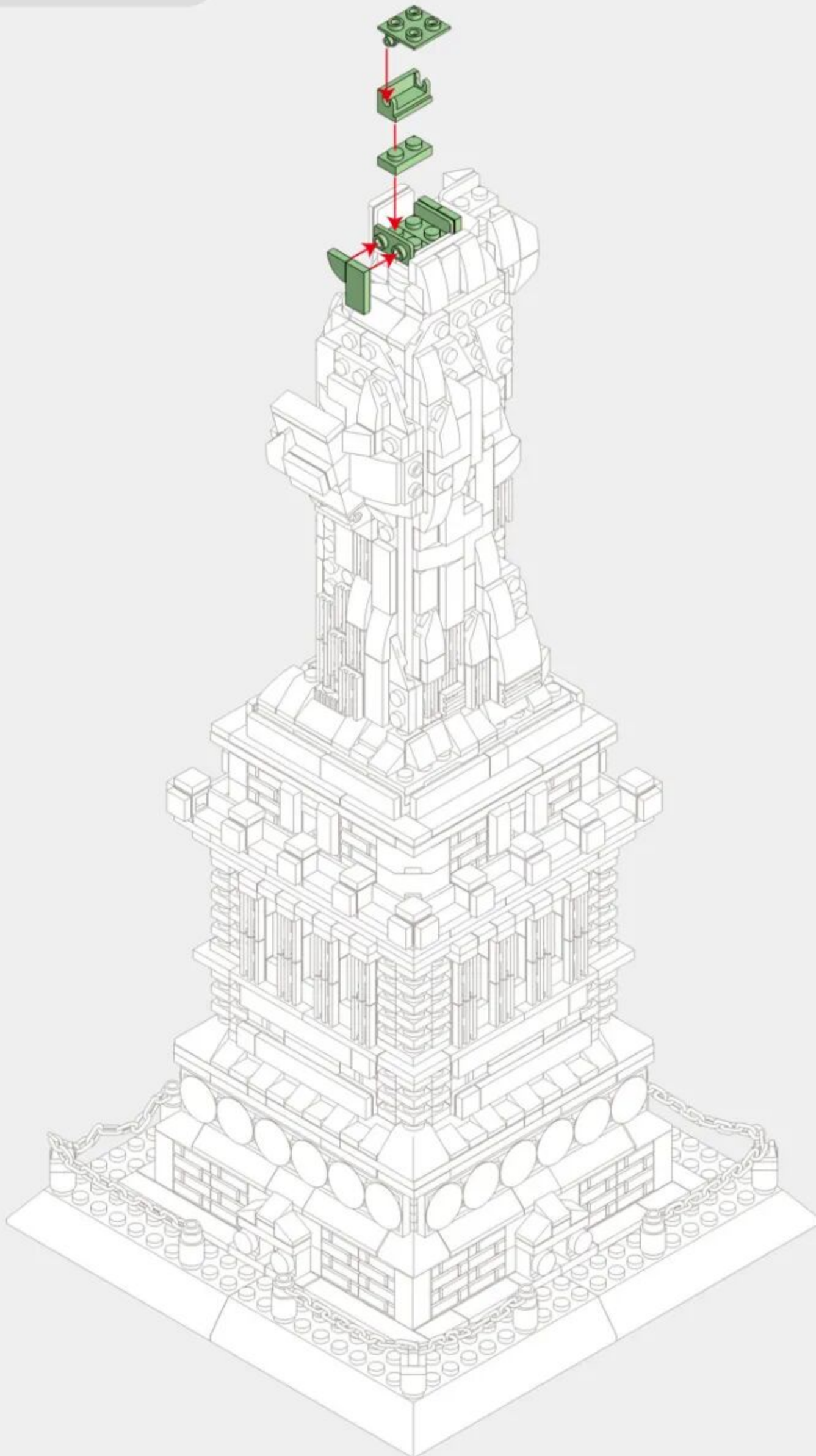
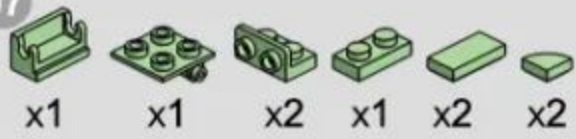

98

4 X 6

4 X 6

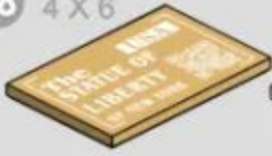

x1

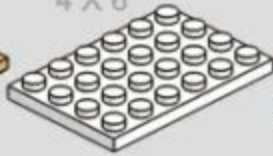

x1



x1

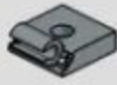

x1



x1



x3



x1



x1

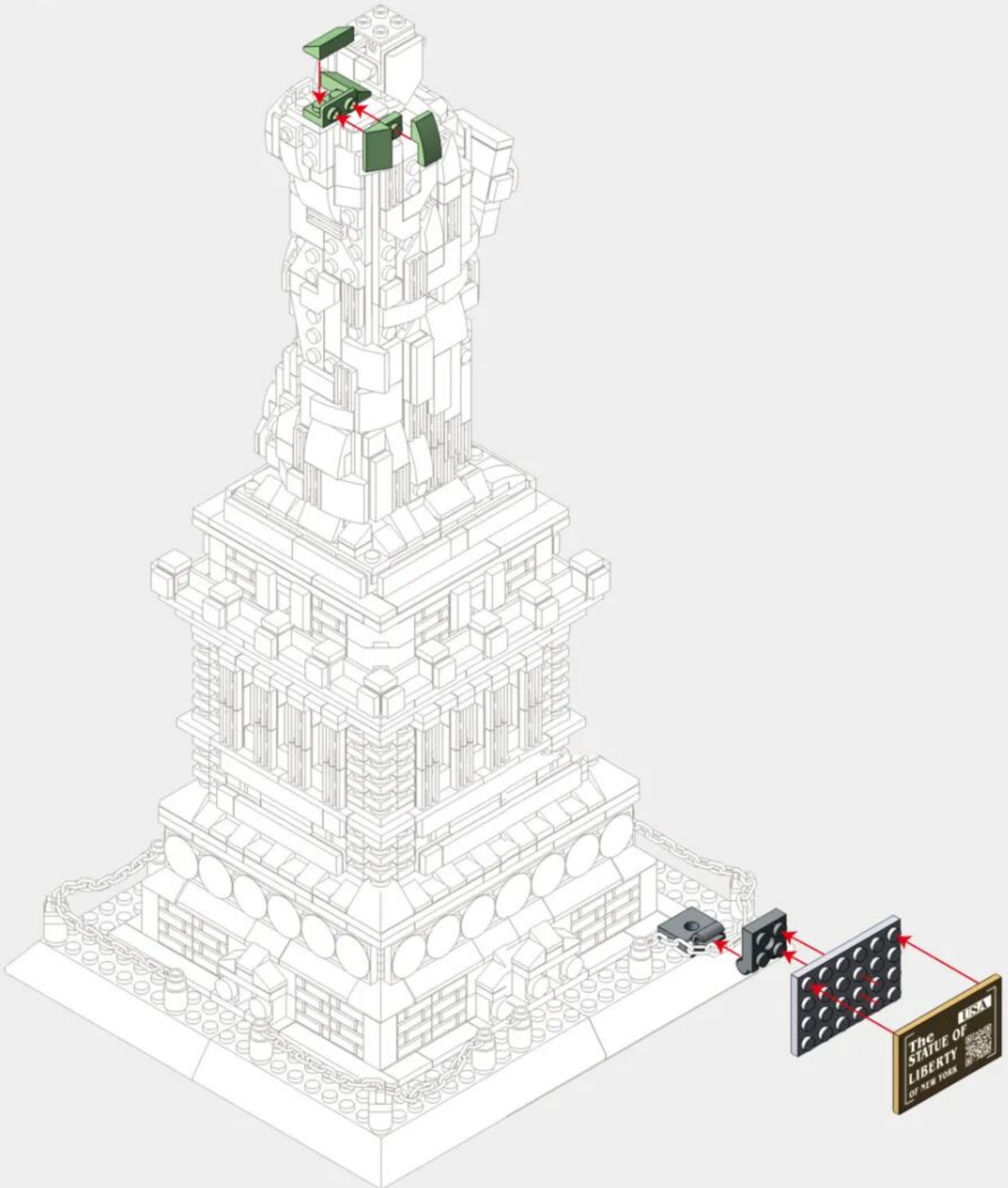

99



x1



x1



x1



x7



x7



x1



x1

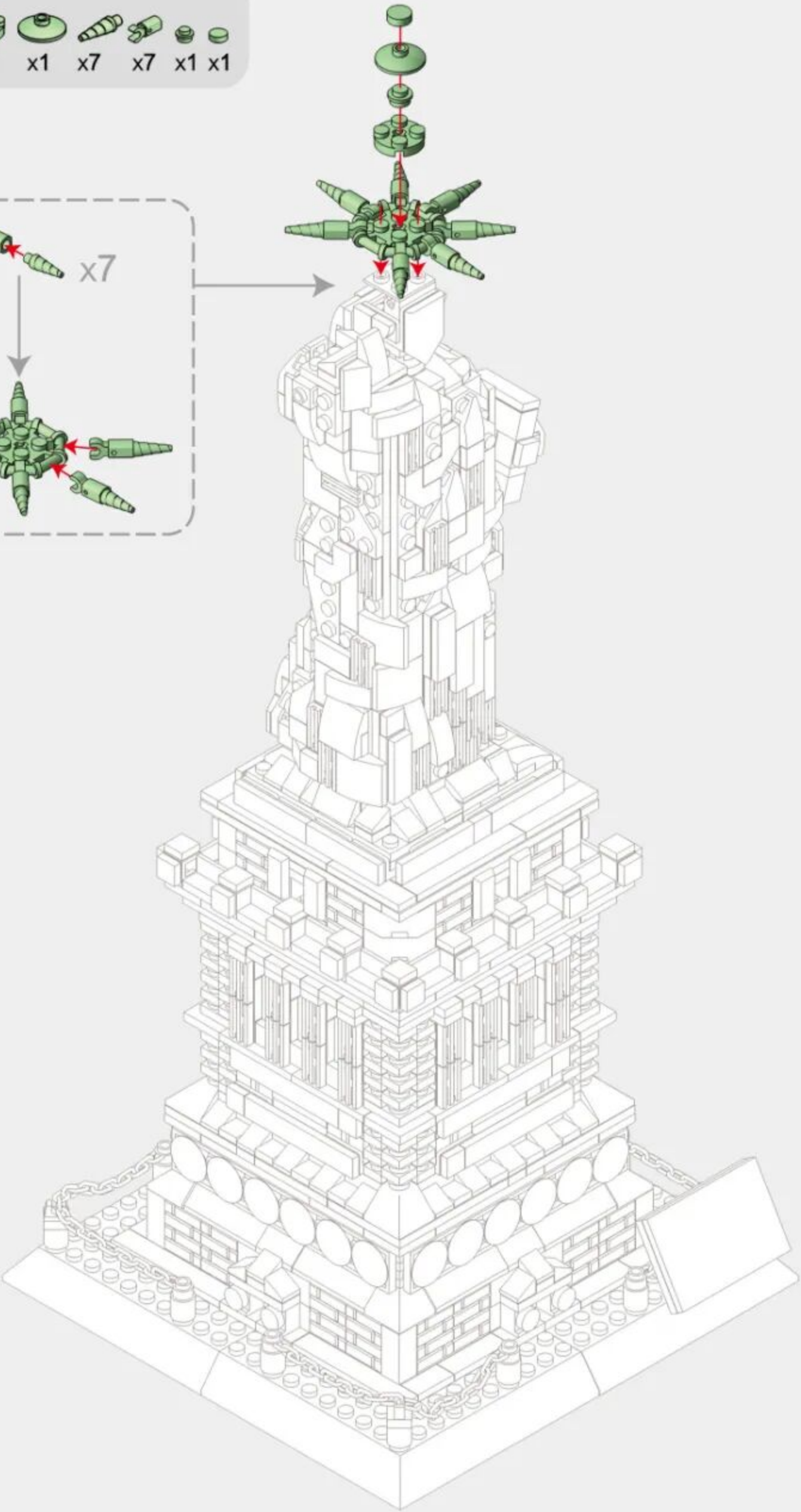
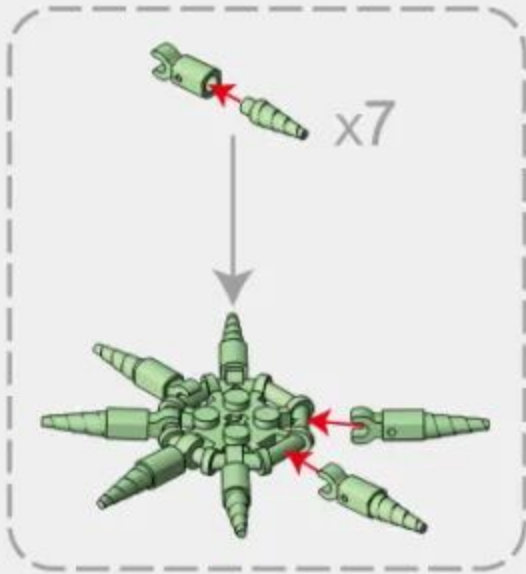

100 1 X 4

- x5
- x1
- x1
- x1
- x1
- x2
- x1
- x2
- x2
- x1
- x2
- x3
- x2
- x1
- x5
- x1
- x1

1

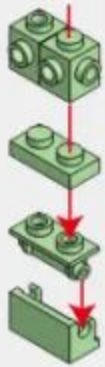

2

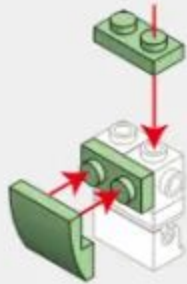

3



4

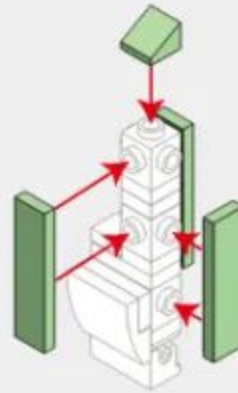

5

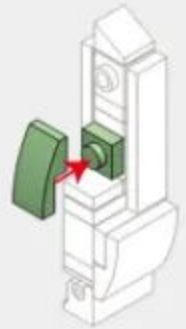

6



7



8



9

5 + 8

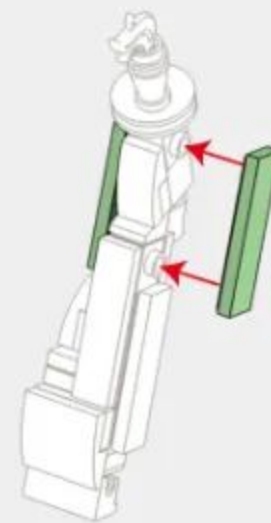

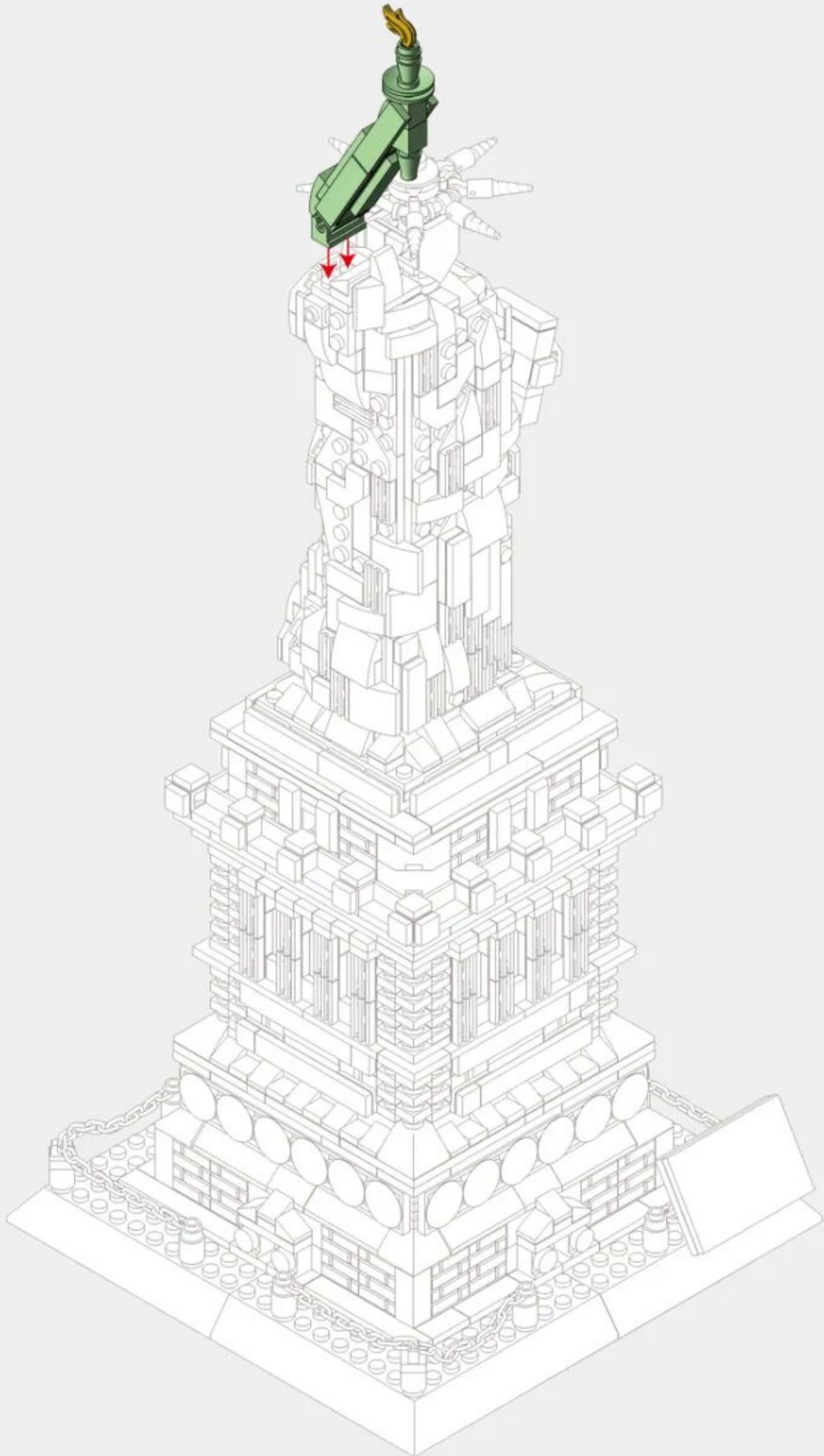



ARCHITECTURE

The World's great architecture

Shaping Skills Imagination & Curiosity Mathematical Self Discovery & Perception Parent-Child Interaction Problem Solving Creativity



✦ THE NIOMON OF KYOTO
Item NO.6212 50X40X11.6MM 2409PCS
京都仁王门



✦ THE COLOSSEUM OF ROME
Item NO.5225 45X30X9MM 1758PCS
罗马斗兽场



✦ THE STATUE OF LIBERTY
Item NO.5227 50X35X8MM 1686PCS
纽约自由女神



✦ THE YELLOW CRANE TOWER OF WUHAN
Item NO.6214 50X40X11.6MM 2912PCS
黄鹤楼



✦ GREAT PYRAMIDS OF GIZA
Item NO.4210 30X40X7MM 643PCS
埃及吉萨金字塔



✦ ELIZABETH TOWER
Item NO.4211 30X40X7MM 910PCS
英国伦敦伊丽莎白塔



✦ FONTANA DI TREVÌ
Item NO.4212 30X40X7MM 688PCS
罗马许愿池



✦ THE LOUVRE
Item NO.4213 30X40X7MM 821PCS
法国巴黎卢浮宫



✦ THE WHITE HOUSE
Item NO.4214 30X40X7MM 979PCS
美国华盛顿白宫



✦ THE CN TOWER-CANADA
Item NO.4215 30X40X7MM 400PCS
加拿大多伦多电视塔



✦ LINCOLN MEMORIAL
Item NO.4216 30X40X7MM 979PCS
美国林肯纪念馆



✦ MARINA BAY SANDS
Item NO.4217 30X40X7MM 881PCS
新加坡金沙酒店

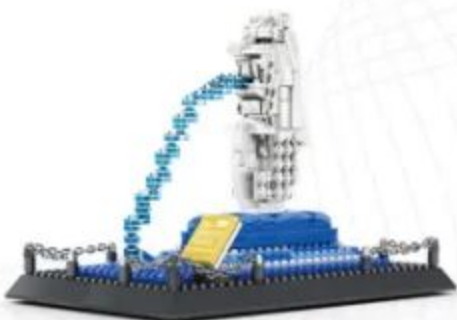

✦ MERLION STATUE-SINGAPORE
Item NO.4218 30X40X7MM 503PCS
新加坡鱼尾狮雕像



✦ THE TOWER BRIDGE OF LODON
Item NO.4219 30X40X7MM 969PCS
伦敦塔桥



✦ FLATIRON BUILDING
Item NO.4220 30X40X7MM 838PCS
美国熨斗大厦



✦ NOTRE-DAME DE PARIS
Item NO.5210 45X30X9MM 1380PCS
法国巴黎圣母院大教堂



✦ **TAJ MAHAL OF AGRA**
Item NO.5211 45X30X9MM 1505PCS
印度阿格拉泰姬陵



✦ **EMPIRE STATE BUILDING**
Item NO.5212 45X30X9MM 1995PCS
美国纽约帝国大厦



✦ **PETRONAS TOWERS**
Item NO.5213 45X30X9MM 1160PCS
马来西亚吉隆坡国油双峰塔

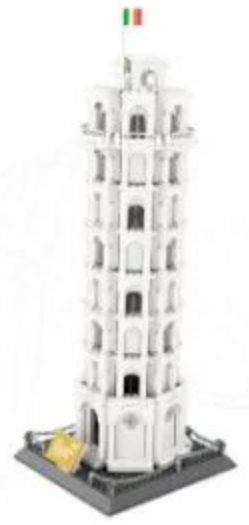

✦ **THE LEANING TOWER**
Item NO.5214 45X30X9MM 1392PCS
意大利比萨斜塔



✦ **THE TOWER BRIDGE**
Item NO.5215 45X30X9MM 1033PCS
英国伦敦双子桥



✦ **THE BIG BEN**
Item NO.5216 45X30X9MM 1642PCS
英国伦敦大笨钟



✦ **THE EIFFEL TOWER**
Item NO.5217 45X30X9MM 978PCS
法国巴黎埃菲尔铁塔



✦ **THE ORIENTAL PEARL TOWER**
Item NO.5224 45X30X9MM 1109PCS
中国上海东方明珠



✦ **THE TIAN AN MEN**
Item NO.5218 45X30X9MM 758PCS
中国北京天安门



✦ **THE SPASSKAYA TOWER**
Item NO.5219 45X30X9MM 1044PCS
俄罗斯克里姆林宫



✦ **THE BURJAL ARAB HOTEL**
Item NO.5220 45X30X9MM 1307PCS
迪拜帆船酒店



✦ **THE TAIPEL 101**
Item NO.5221 45X30X9MM 1511PCS
中国台北101大楼



✦ **THE TEMPLE OF HEAVEN**
Item NO.5222 45X30X9MM 1052PCS
中国北京故宫天坛



✦ **THE GOLDEN GATE BRIDGE**
Item NO.6210 54X42X10MM 1977PCS
美国旧金山金门大桥



✦ **THE BRANDENBURG**
Item NO.6211 54X42X10MM 1552PCS
德国勃兰登堡门



✦ **THE IMPERIAL HOTEL**
Item NO.5226 500X350X80MM 1375PCS
东京帝国饭店



✦ **THE TRIUMPHAL ARCH**
Item NO.5223 45X30X9MM 1401PCS
法国巴黎凯旋门



THE STATUE OF LIBERTY OF NEW YORK

COUNTRY: America

CITY: New York

INTRODUCTION

The Statue of Liberty (Liberty Enlightening the World; French: La Liberté éclairant le monde) is a colossal neoclassical sculpture on Liberty Island in New York Harbor in New York, in the United States. The copper statue, a gift from the people of France to the people of the United States, was designed by French sculptor Frédéric Auguste Bartholdi and its metal framework was built by Gustave Eiffel. The statue was dedicated on October 28, 1886.

The statue is a figure of Libertas, a robed Roman liberty goddess. She holds a torch above her head with her right hand, and in her left hand carries a tabula ansata inscribed JULY IV MDCCLXXVI (July 4, 1776 in Roman numerals), the date of the U.S. Declaration of Independence. A broken shackle and chain lie at her feet as she walks forward, commemorating the recent national abolition of slavery. After its dedication, the statue became an icon of freedom and of the United States; it has been a welcoming sight to immigrants arriving by sea.

Bartholdi was inspired by a French law professor and politician, Édouard René de Laboulaye, who is said to have commented in 1865 that any monument raised to U.S. independence would properly be a joint project of the French and U.S. peoples. Because of the post-war instability in France, work on the statue did not commence until the early 1870s. In 1875, Laboulaye proposed that the French finance the statue and the U.S. provide the site and build the pedestal. Bartholdi completed the head and the torchbearing arm before the statue was fully designed, and these pieces were exhibited for publicity at international expositions.

The torchbearing arm was displayed at the Centennial Exposition in Philadelphia in 1876, and in Madison Square Park in Manhattan from 1876 to 1882. Fundraising proved difficult, especially for the Americans, and by 1885 work on the pedestal was threatened by lack of funds. Publisher Joseph Pulitzer, of the *New York World*, started a drive for donations to finish the project and attracted more than 120,000 contributors, most of whom gave less than a dollar. The statue was built in France, shipped overseas in crates, and assembled on the completed pedestal on what was then called Bedloe's Island. The statue's completion was marked by New York's first ticket-tape parade and a dedication ceremony presided over by President Grover Cleveland.

The statue was administered by the United States Lighthouse Board until 1901 and then by the Department of War; since 1933 it has been maintained by the National Park Service as part of the Statue of Liberty National Monument, and is a major tourist attraction. It closed beginning March 16, 2020 because of the 2019–20 coronavirus pandemic. Public access to the balcony around the torch has been barred since 1916.

La libertad iluminando el mundo (en inglés: Liberty Enlightening the World; en francés: La Liberté éclairant le monde), conocida como la Estatua de la Libertad, es uno de los monumentos más famosos de Nueva York, de los Estados Unidos y de todo el mundo. Se encuentra en la isla de la Libertad al sur de la isla de Manhattan, junto a la desembocadura del río Hudson y cerca de la isla Ellis. La Estatua de la Libertad fue un regalo del gobierno francés al gobierno estadounidense en 1886 para conmemorar el centenario de la Declaración de Independencia de los Estados Unidos y como un signo de amistad entre las dos naciones. Fue inaugurada el 28 de octubre de 1886 en presencia del presidente estadounidense de la época, Grover Cleveland. La estatua es obra del escultor francés Frédéric Auguste Bartholdi y la estructura interna fue diseñada por el ingeniero Alexandre Gustave Eiffel. El arquitecto francés Eugène Viollet-le-Duc se encargó de la elección de los cobres utilizados para la construcción de la estatua. El 15 de octubre de 1924, la estatua fue declarada como monumento nacional de los Estados Unidos y el 15 de octubre de 1965 se añadió la isla Ellis. Desde 1984 es considerada Patrimonio de la Humanidad por la Unesco. La Estatua de la Libertad, además de ser un monumento importante en la ciudad de Nueva York, se convirtió en un símbolo en Estados Unidos y representa, en un plano más general, la libertad y emancipación con respecto a la opresión. Desde su inauguración en 1886, la estatua fue la primera visión que tenían los inmigrantes europeos al llegar a Estados Unidos tras su travesía por el océano Atlántico. En términos arquitectónicos, la estatua recuerda al famoso Coloso de Rodas, una de las siete maravillas del mundo antiguo. Fue nominada para las nuevas siete maravillas del mundo, donde resultó finalista. El nombre asignado por la Unesco es Monumento Nacional Estatua de la Libertad. Desde el 10 de junio de 1933 se encarga de su administración el Servicio de Parques Nacionales de los Estados Unidos.



America
The world's great architecture

