



STATUE OF LIBERTY

ESTATUA DE LA LIBERTAD

New York ,America

The world's great architecture



Creative Ability



Family Interaction



Observation Ability



Thinking Ability



Practical Ability



6+
Suitable Age

5227
Product Number

1409 PCS
Parts Total



Architecture

It will be a city...

这将构成一座城市...

ABOUT THE PRODUCT

关于产品

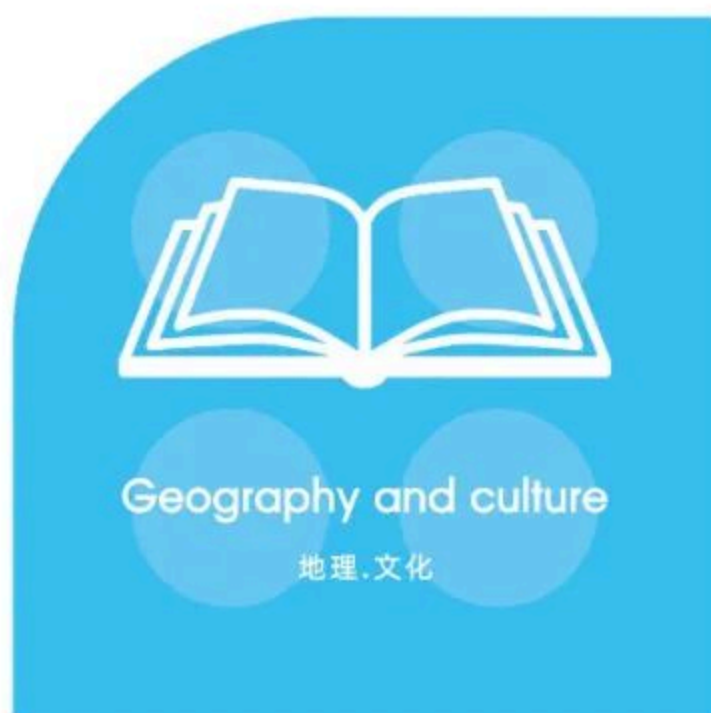

ARCHITECTURE

WANGE The world's great architect since 1991

Statue of Liberty



The Statue of Liberty is a colossal neoclassical sculpture on Liberty Island in New York Harbor, within New York City.

Statue of Liberty



Geography and culture

地理·文化



The Statue of Liberty is a colossal neoclassical sculpture on Liberty Island in New York Harbor, the copper statue, a gift to the U.S. from the people of France, the statue was dedicated on October 28, 1886.





美国纽约自由女神像

Statue of ■ Liberty America

The contents of this chapter refer to the Wikipedia website.

本章内容参考维基百科网站，
更多资讯可自行查阅。

The world's great architecture

Buildings and layout

■ 建筑物和布局



The statue is a figure of Libertas, the Roman goddess of liberty. She holds a torch above her head with her right hand, and in her left hand carries a tabula ansata inscribed JULY IV MDCCLXXVI (July 4, 1776, in Roman numerals), the date of the U.S. Declaration of Independence. A broken chain and shackle lie at her feet as she walks forward, commemorating the national abolition of slavery following the American Civil War. After its dedication the statue became an icon of freedom and of the United States, being subsequently seen as a symbol of welcome to immigrants arriving by sea.

La estatua es una figura de Libertas, la diosa romana de la libertad. Sostiene una antorcha sobre su cabeza con su mano derecha y en su mano izquierda lleva una tabula ansata con la inscripción JULIO IV MDCCLXXVI (4 de julio de 1776, en números romanos), la fecha de la Declaración de Independencia de Estados Unidos. Una cadena rota y un grillete yacen a sus pies mientras camina hacia adelante, conmemorando la abolición nacional de la esclavitud después de la Guerra Civil estadounidense. Tras su dedicación, la estatua se convirtió en un icono de la libertad y de los Estados Unidos, siendo posteriormente vista como un símbolo de bienvenida a los inmigrantes que llegaban por mar.



Symbolism

The idea for the statue was born in 1865, when the French historian and abolitionist Édouard de Laboulaye proposed a monument to commemorate the upcoming centennial of U.S. independence (1876), the perseverance of American democracy and the liberation of the nation's slaves.

La Estatua de la Libertad, además de ser un monumento importante en la ciudad de Nueva York, se convirtió en un símbolo en Estados Unidos y representa, en un plano más general, la libertad y emancipación con respecto a la opresión. Desde su inauguración en 1886, la estatua fue la primera visión que tenían los inmigrantes europeos al llegar a Estados Unidos tras su travesía por el océano Atlántico. En términos arquitectónicos, la estatua recuerda al famoso Coloso de Rodas, una de las siete maravillas del mundo antiguo. Fue nominada para las nuevas siete maravillas del mundo moderno, donde resultó finalista.



Design and construction

According to author Louis Auchincloss, the pedestal "craggily evokes the power of an ancient Europe over which rises the dominating figure of the Statue of Liberty". The committee hired former army General Charles Pomeroy Stone to oversee the construction work. Construction on the 15-foot-deep (4.6 m) foundation began in 1883, and the pedestal's cornerstone was laid in 1884. In Hunt's original conception, the pedestal was to have been made of solid granite. Financial concerns again forced him to revise his plans; the final design called for poured concrete walls, up to 20 feet (6.1 m) thick, faced with granite blocks. This Stony Creek granite came from the Beattie Quarry in Branford, Connecticut. The concrete mass was the largest poured to that time.

La estructura está recubierta con una fina capa de cobre, que reposa sobre un gran armazón de acero inoxidable (que inicialmente era de hierro), a excepción de la llama que está recubierta con láminas de oro. La estructura reposa sobre una base de forma cuadrada, que a su vez se apoya sobre un primer zócalo en forma de estrella irregular de once puntas. La altura de la Estatua de la Libertad es de 46 metros, y alcanza los 93 metros desde el suelo hasta la antorcha.⁶¹ Al pie de la estructura se encuentran cadenas rotas que simbolizan la libertad. La estatua está orientada hacia el Este, es decir hacia Europa, con la que los Estados Unidos comparten pasado y valores.

Force Balance

受力平衡

Physical operations

物理运算

$$F = G \frac{m_1 m_2}{d^2}$$

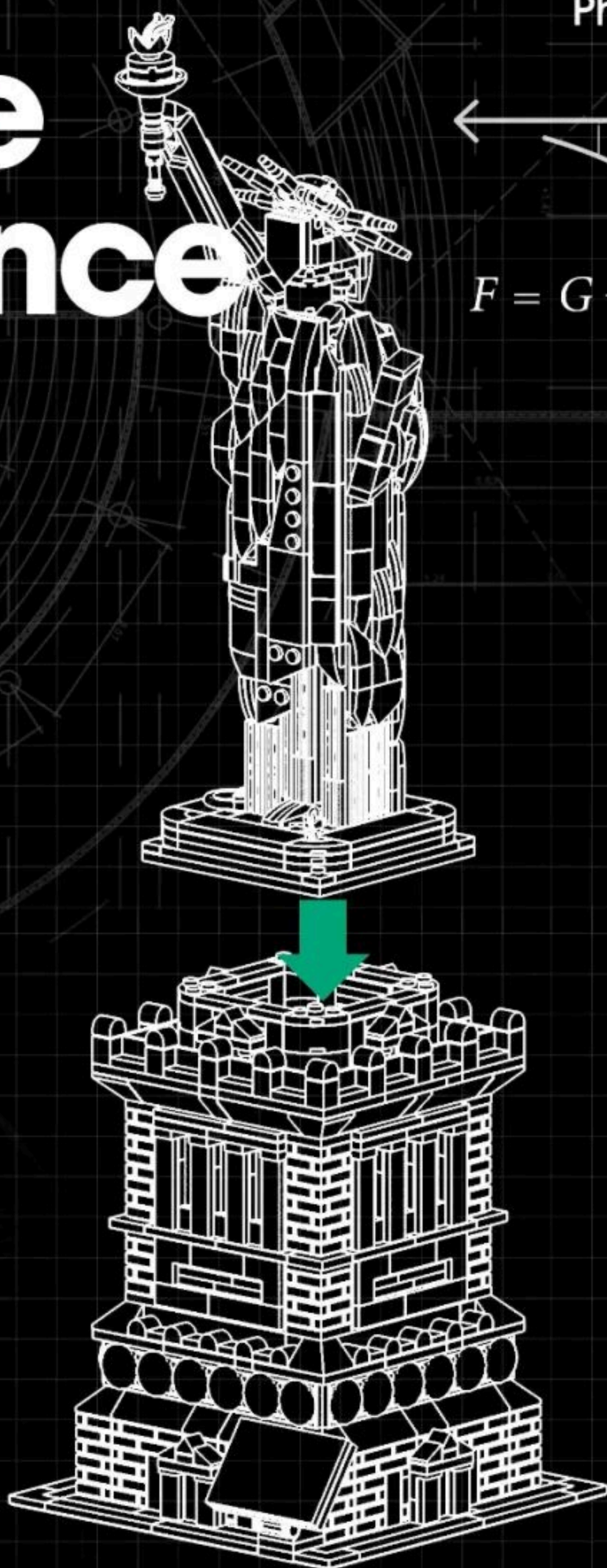

Creation and thinking

创作·思考

Special parts

特殊零件的开发利用

$$S=4\pi \cdot r^2$$



$$a^2+b^2=c^2$$

WG1223

矮柱球带柄



WG0465

加高1孔



WG1293

小吊环



WG1320

方正转角3孔

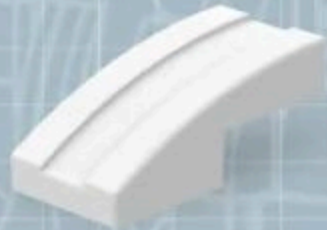

WG0930

拱形连接件

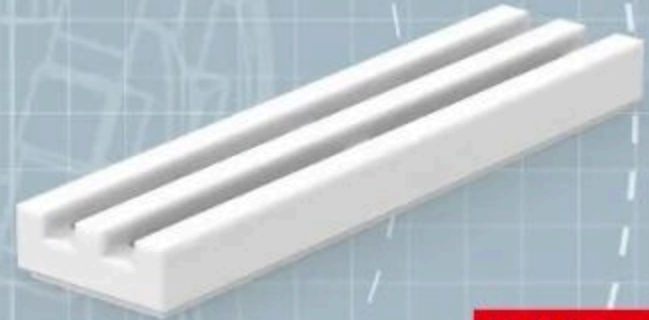

WG1321

2倍平双线



WG1345

竖纹2倍2孔



WG1631

矮半圆2孔



$$\sin^2 a + \cos^2 a = 1$$

WG1377

矮3x4孔



features and functions

特点.功能

Main Color Matching

配色方案



Pantone Black 6C



Pantone 431C



Pantone Cool Gray 6C

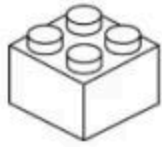

White



Pantone 2310C



Pantone 7509C



Pantone 7500C



Pantone 2407C

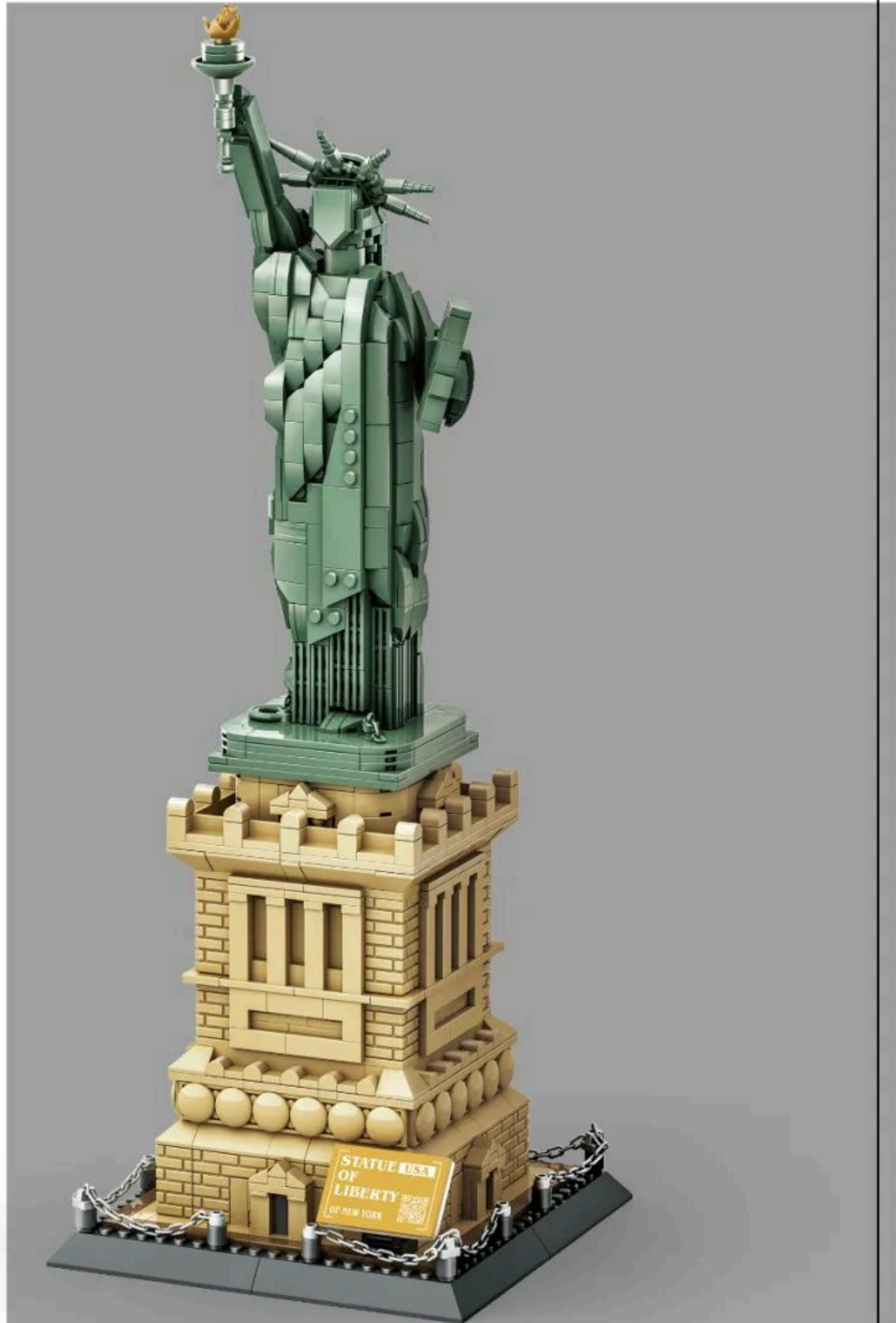

Color matching

Adopting 2 main colors, Midnight green and beige color as the main color, the more reasonable and bold color matching on the original building, making the product more atmospheric and the whole design is more reasonable.

Statue of Liberty

美国纽约自由女神像



Back

491mm



176mm

Left

491mm



176mm

Front

491mm



176mm

Product Size: 176X176x491mm

Creative Ability



Family Interaction



Observation Ability



Thinking Ability



Practical Ability



小提示：积木包分为底板包、整版配件包及普通配件包，底板包标识为A/B/C...，普通配件包编码与说明书对应，整版配件包无标识。
 Tip: Building block packs are divided into baseplate packs, runner accessory packs, and standard accessory packs. Baseplate packs are labeled A/B/C..., regular accessory packs have codes that correspond to the instructions, and runner accessory packs have no labels.



- Open the product packaging correctly and classify the building block packs by type.

用正确方式拆解产品外包装,按积木包类型进行分类。



- Confirm the quantity of building block packs and cross-check them with the pack identifiers and the instructions.

确认积木包数量, 对照积木包标识和说明书步骤。



- Open the building block packs according to the pack identifier steps. Sort them in order by type and color for easier assembly.

按积木包标识步骤拆开积木包,按顺序以类型、颜色进行分类以便搭建。



- Assemble your building block model following the steps in the instruction manual.

按说明书步骤拼装并完成你的积木模型。



1:1 Physical Reference Table

十字棒配件1:1尺寸参照表



Instructions For Use

让安装更简单

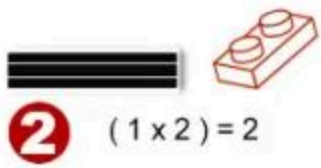

2 $(1 \times 2) = 2$

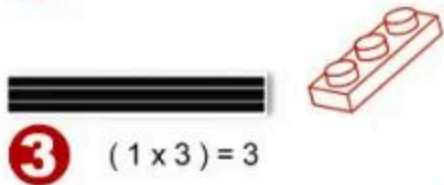

3 $(1 \times 3) = 3$

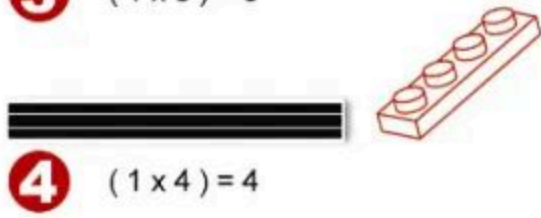

4 $(1 \times 4) = 4$



5 $(1 \times 5) = 5$



6 $(1 \times 6) = 6$



7 $(1 \times 7) = 7$



8 $(1 \times 8) = 8$



9 $(1 \times 9) = 9$



10 $(1 \times 10) = 10$



12 $(1 \times 12) = 12$











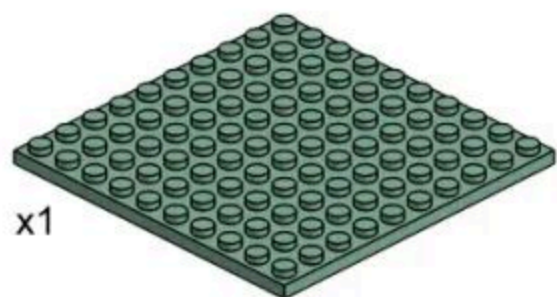





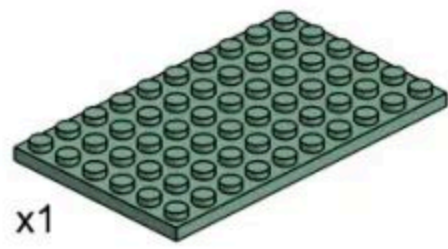

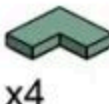

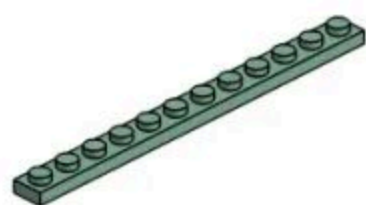
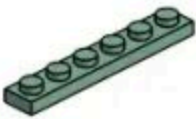









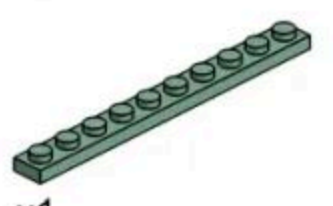





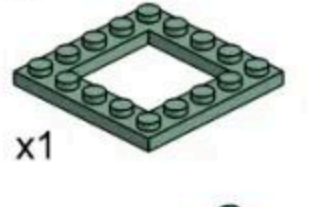





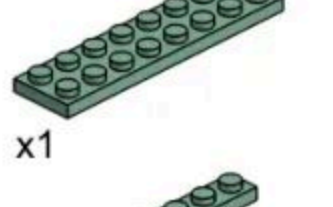
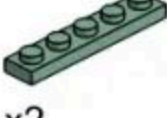



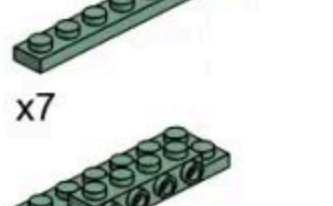





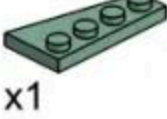



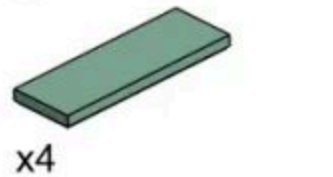





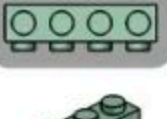































16 $(1 \times 16) = 16$



PARTS LIST













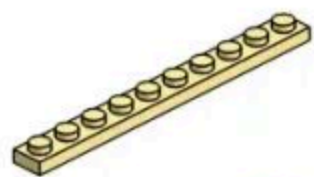

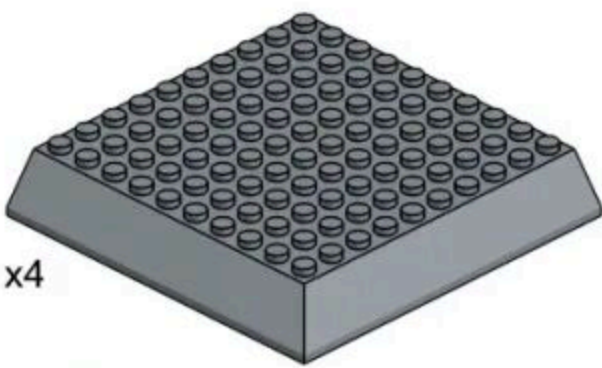



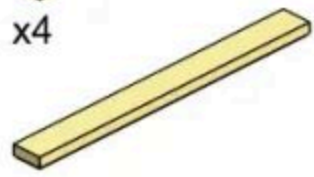





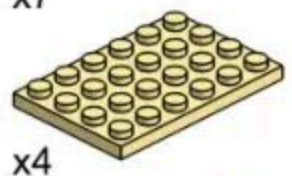





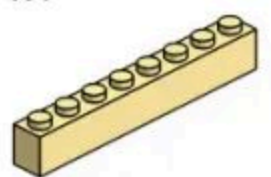







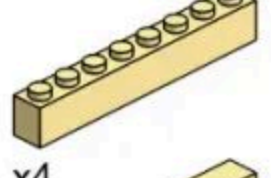





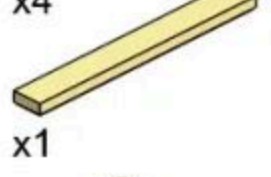







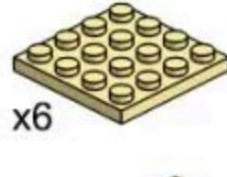





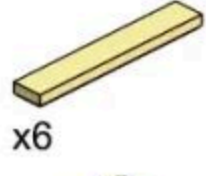



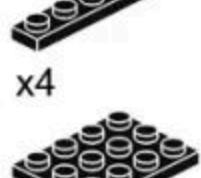

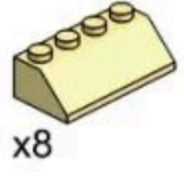



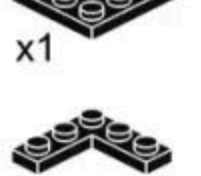

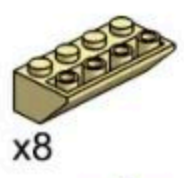







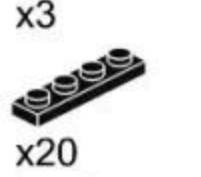



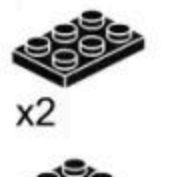





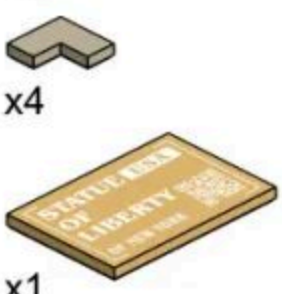

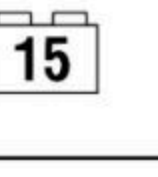

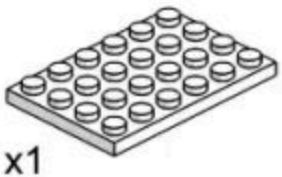

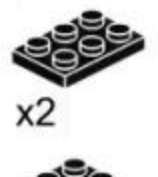







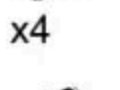
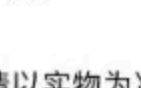

配件清单

 x1	 x1	 x6	 x12	 x1	 x3
 x1	 x6	 x4	 x4	 x6	 x3
 x1	 x5	 x8	 x15	 x2	 x3
 x1	 x2	 x8	 x6	 x21	 x3
 x1	 x2	 x12	 x4	 x8	 x10
 x1	 x2	 x2	 x1	 x7	 x8
 x1	 x2	 x2	 x1	 x1	 x8
 x1	 x4	 x1	 x3	 x2	 x1
 x7	 x1	 x3	 x2	 x3	 x5
 x1	 x1	 x1	 x2	 x34	 x21
 x6	 x4	 x4	 x3	 x1	 x1
x4	 x1	 x1	 x1	 x1	 x17
	 x4	 x2	 x3	 x2	 x26
	 x1	 x3	 x2	 x4	 x4
		 x4	 x3	 x7	 x1
		 x1	 x3	 x1	 x3
		 x7	 x1	 x35	 x2
		 x8	 x2	 x2	 x1
			 x25	 x7	 x2
				 x7	 x5

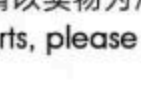
产品有增补件请以实物为准
If product has additional parts, please in kind prevail.

PARTS LIST

配件清单

						
x2	x8	x1	x4	x4	x4	
						
x2	x1		x7	x8	x24	
						
x8	x1	x14	x4	x4	x8	
						
x4	x17		x4		x4	
						
x4	x5	x12	x4	x16	x4	
						
x4		x12	x1	x22		
						
x2	x8	x1	x6	x4	x12	
						
x4		x14	x6	x8	x4	
						
x4		x12	x8	x4	x12	
						
x4		x20	x8	x4	x3	
		x4	x8	x4		
x4		x8	x8	x4	x5	
		x8	x8	x4		
x1		x8	x8	x20	x1	
		x8	x8	x4		
x8		x8	x8	x16	x4	
		x8	x8	x4		
x3		x36	x12	x8	x1	
		x4	x4	x8		
x20		x16	x4	x28	x1	
		x8				
x2		x8			x1	
		x36	x12			
x1		x44	x4		x1	
		x4	x12			
		x4	x12			
		x4	x12			

产品有增补件请以实物为准

If product has additional parts, please in kind prevail.



286PCS

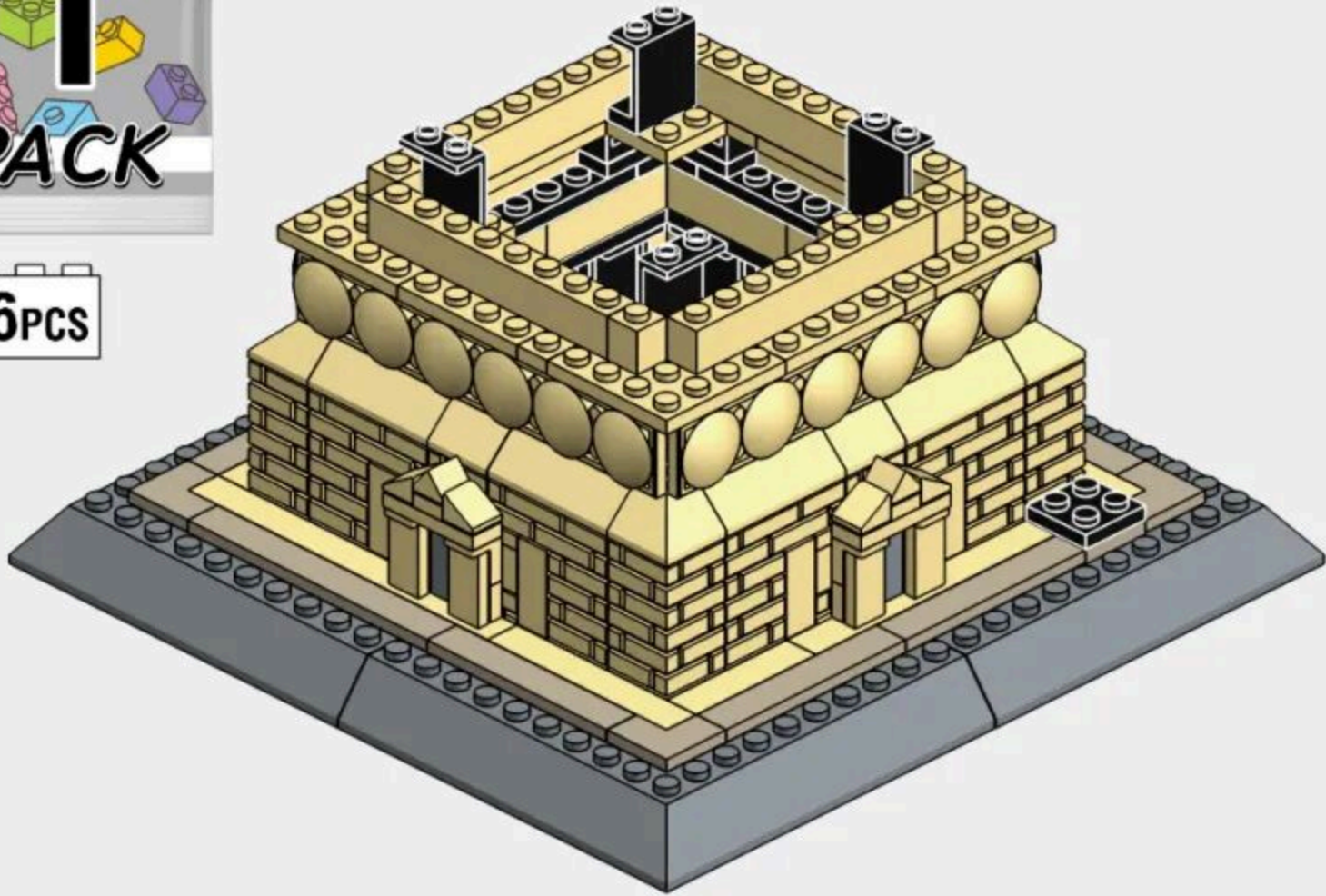

1-1

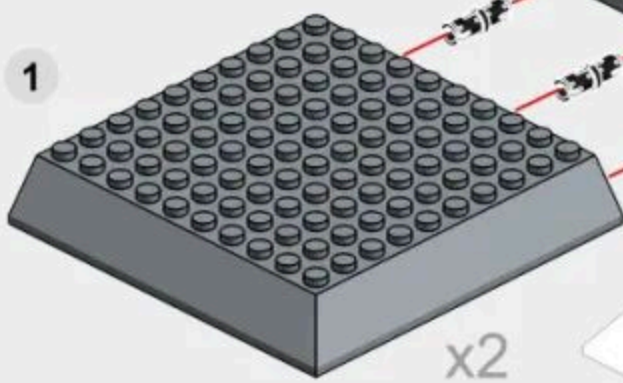
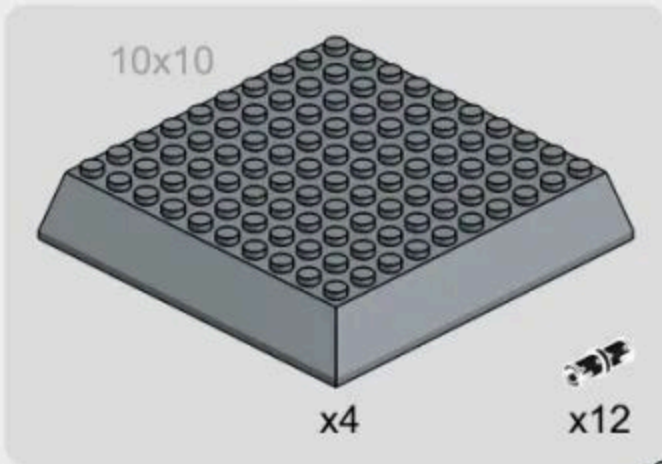

x2

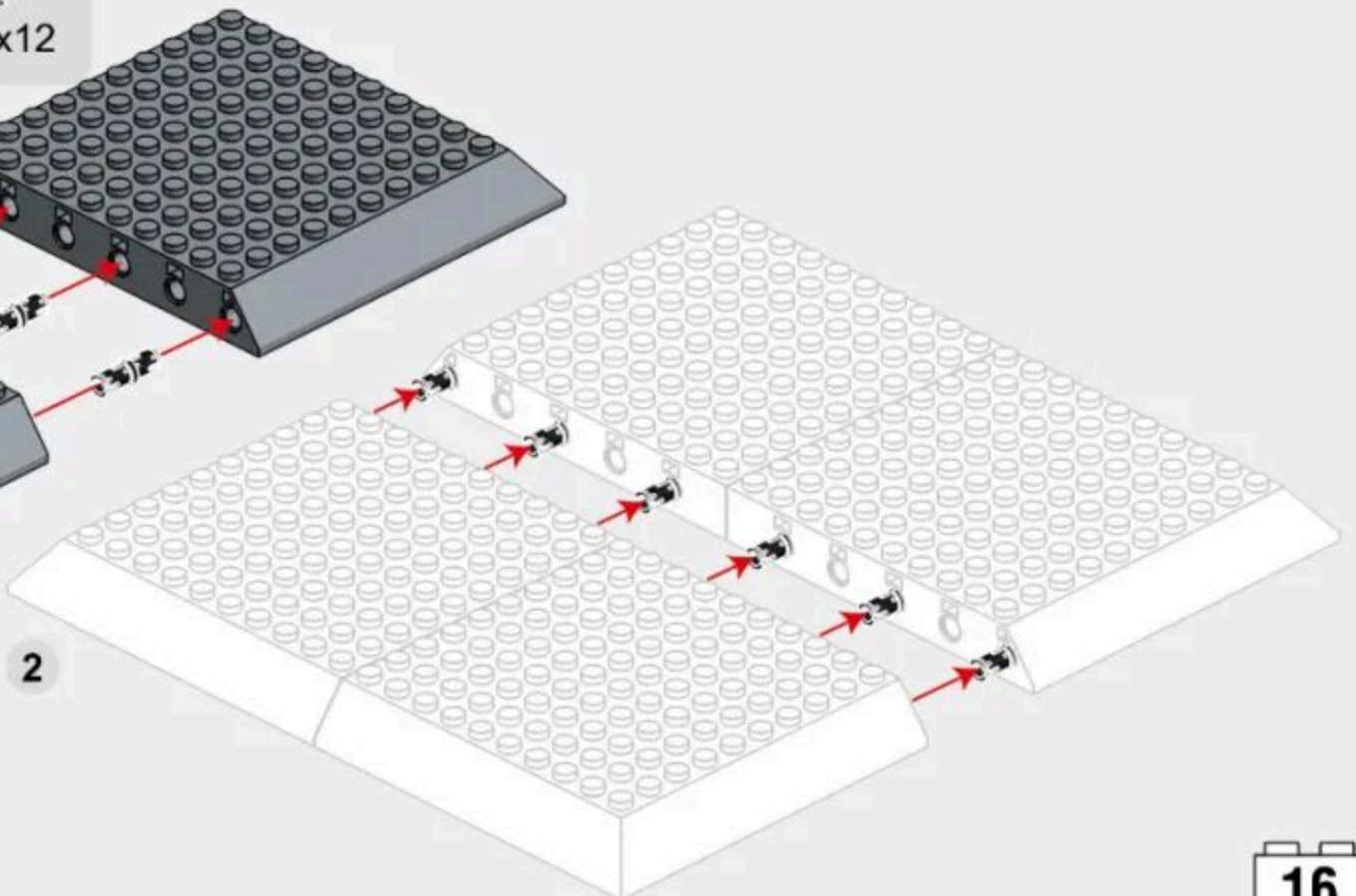

微信扫一扫
补件更简单

1-2

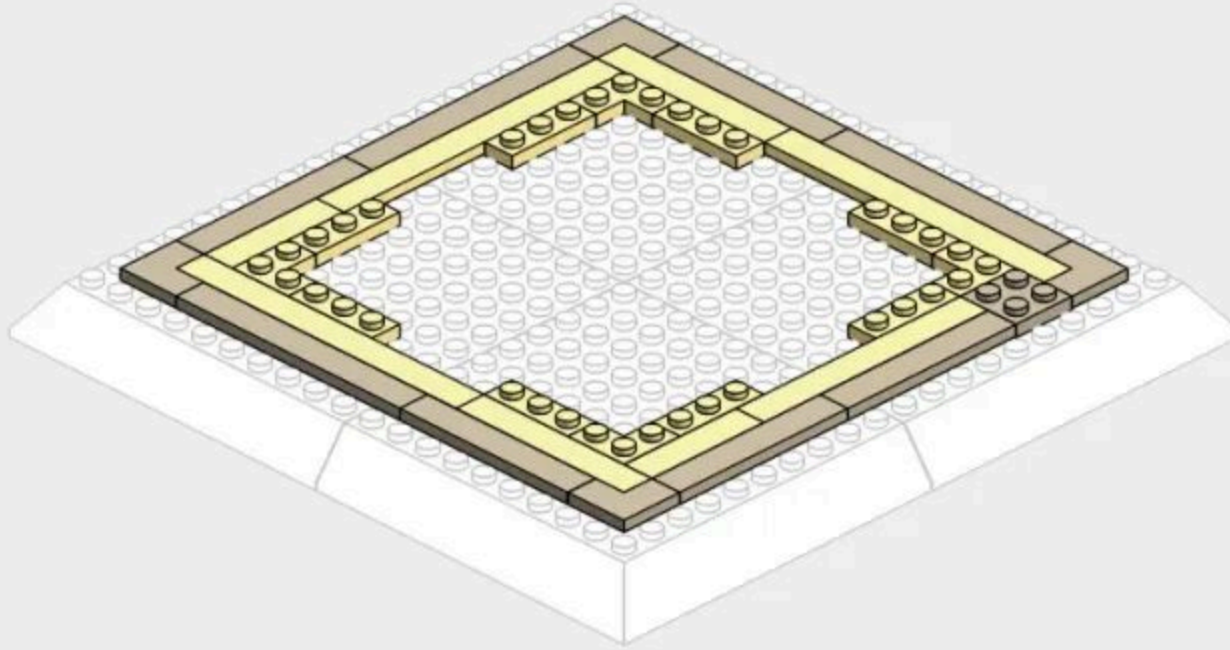
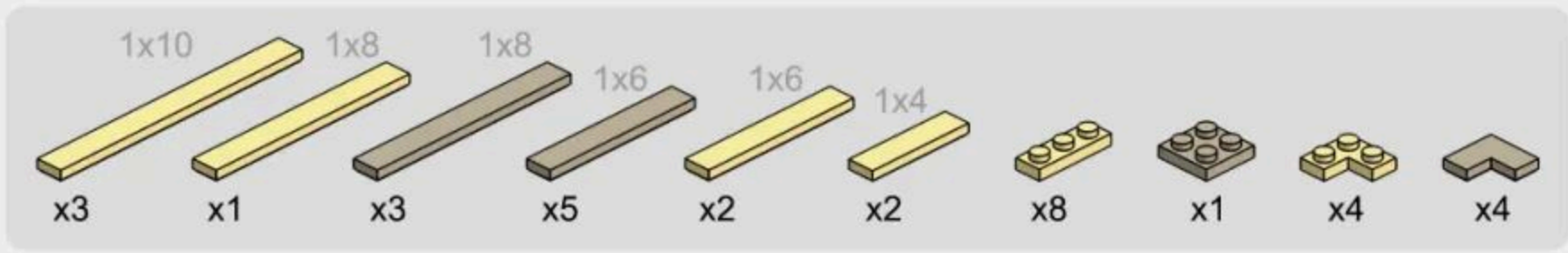

1-3

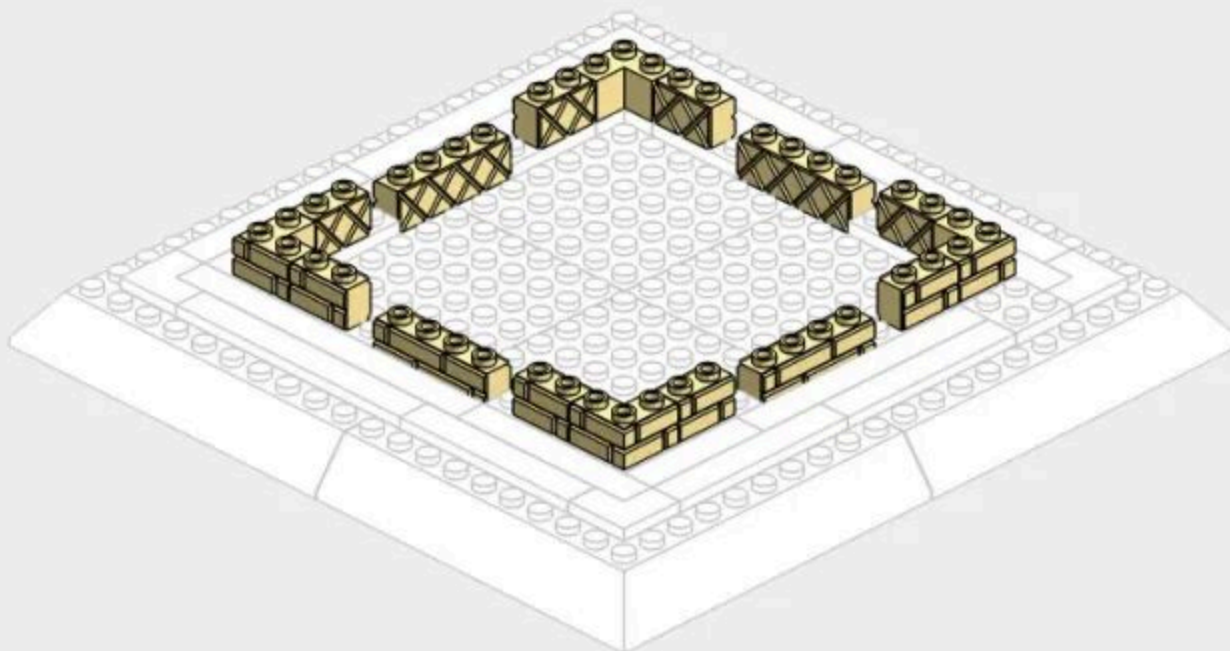

1-4

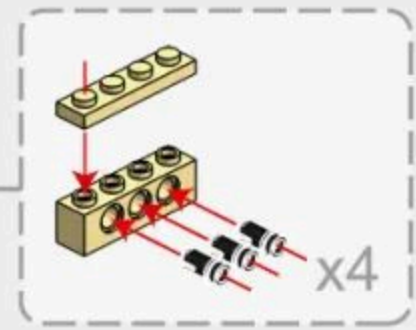
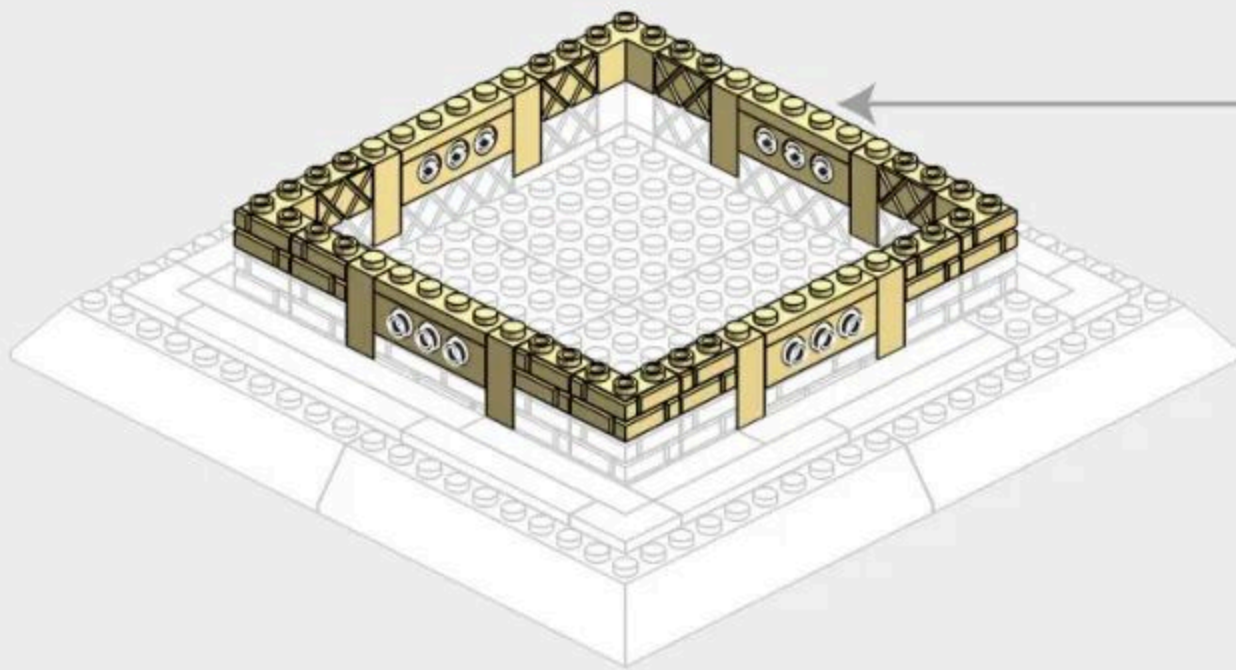

1-5

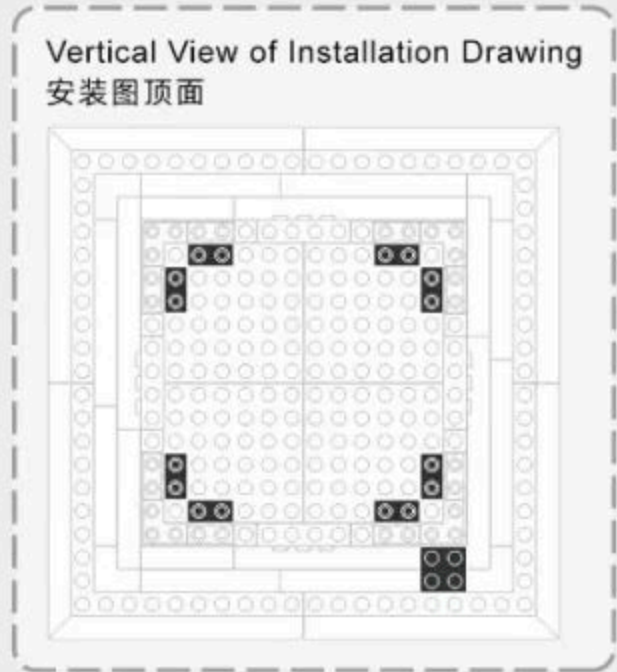
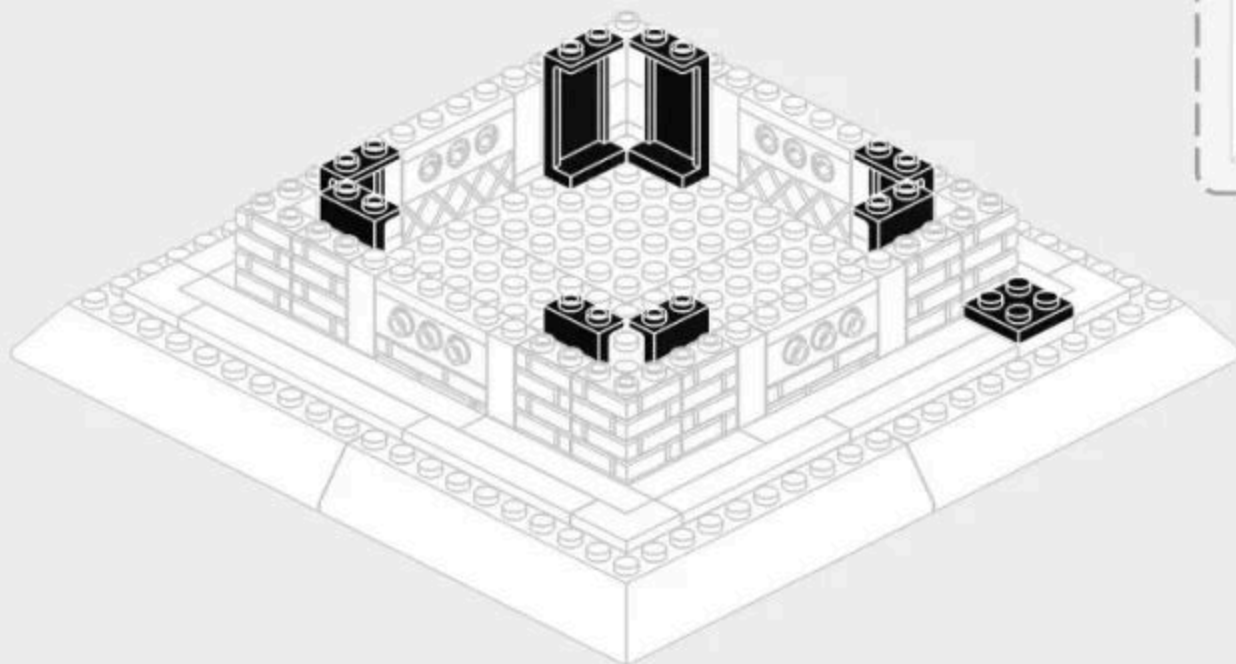
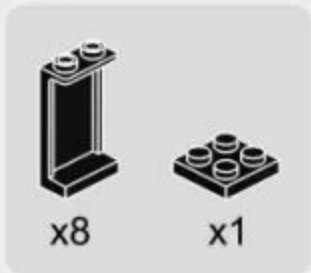

1-12

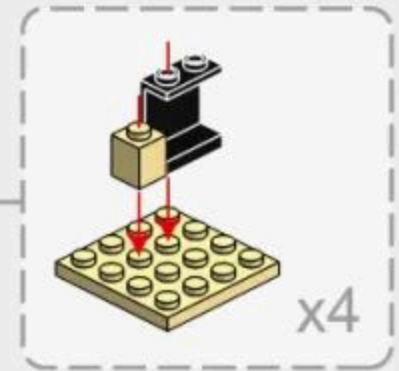
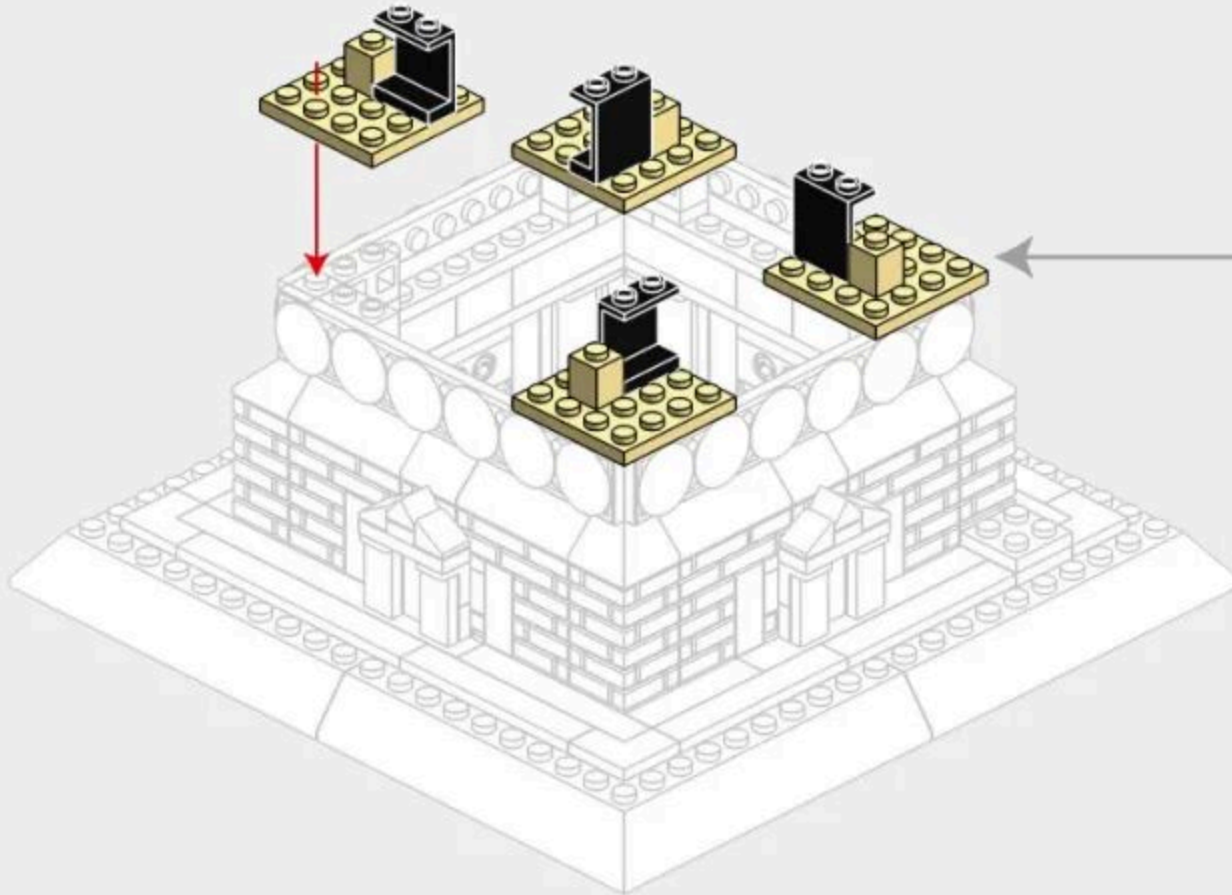
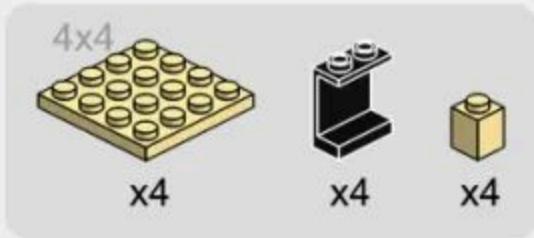

1-13

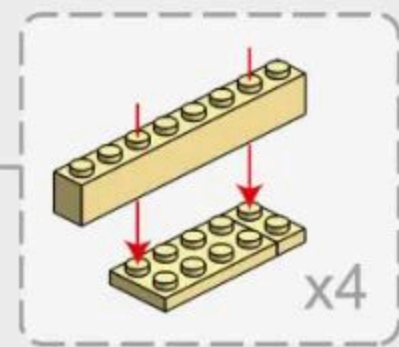
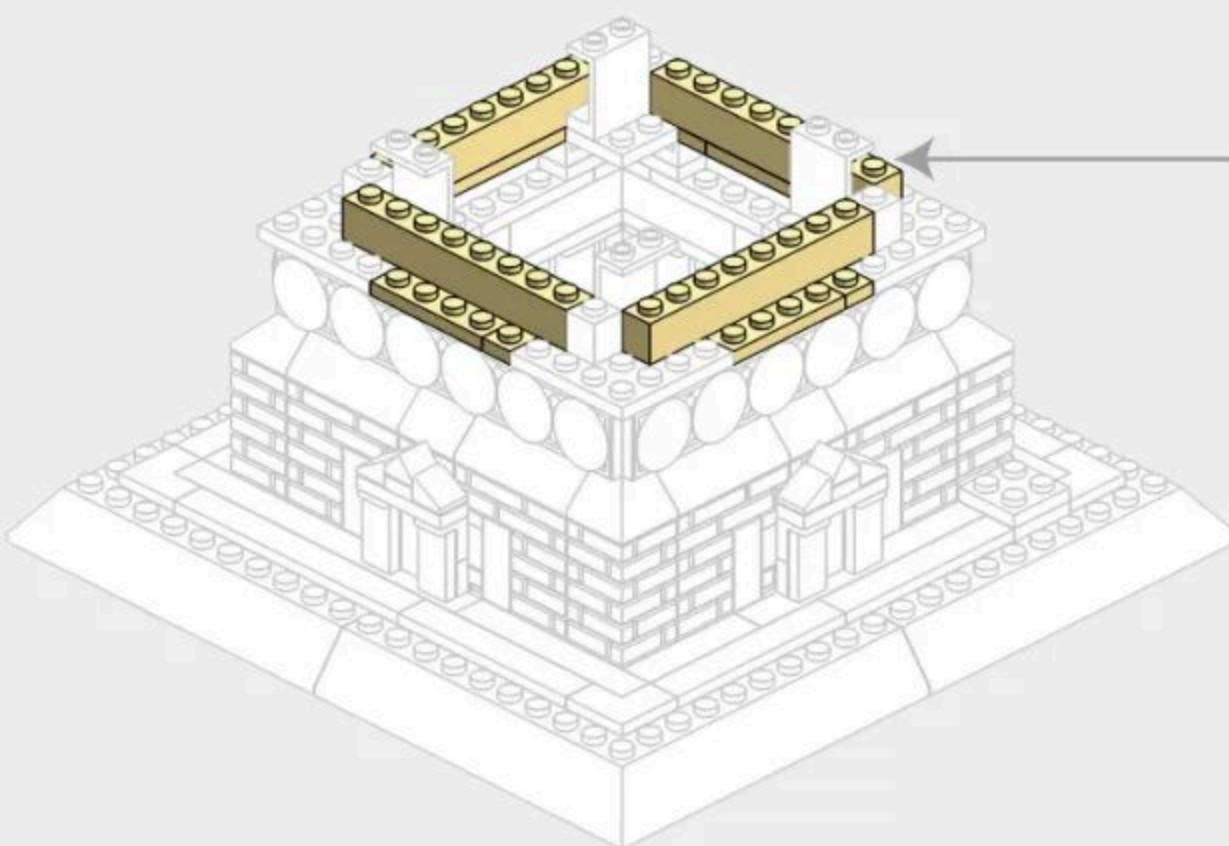
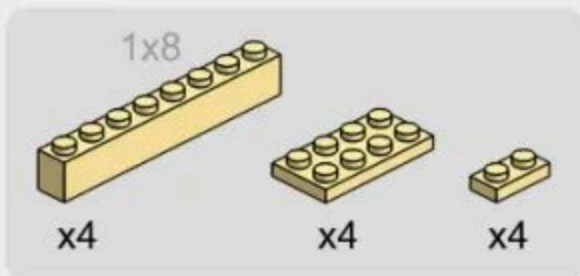



282PCS

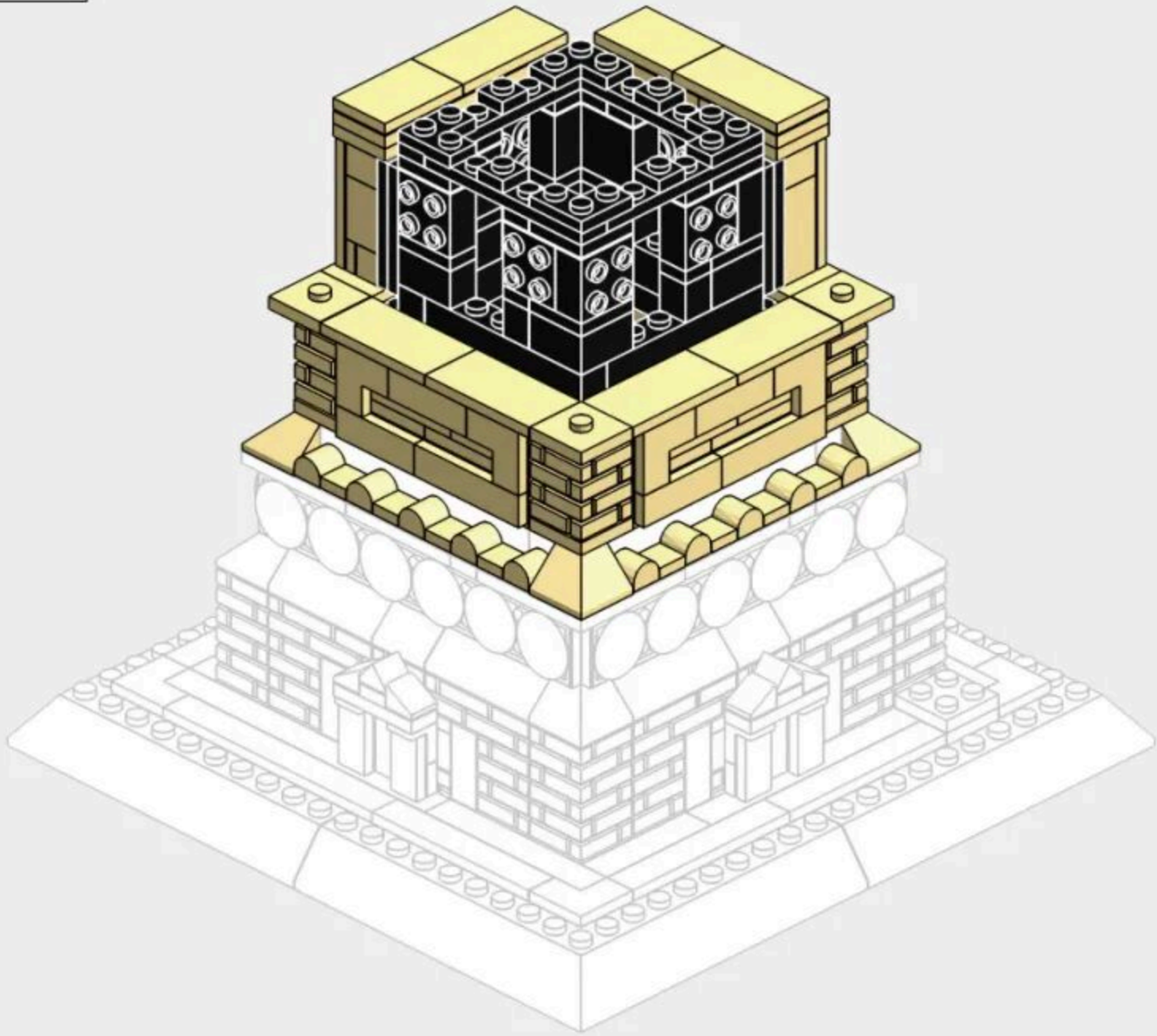

2-1



x4



x20



x16

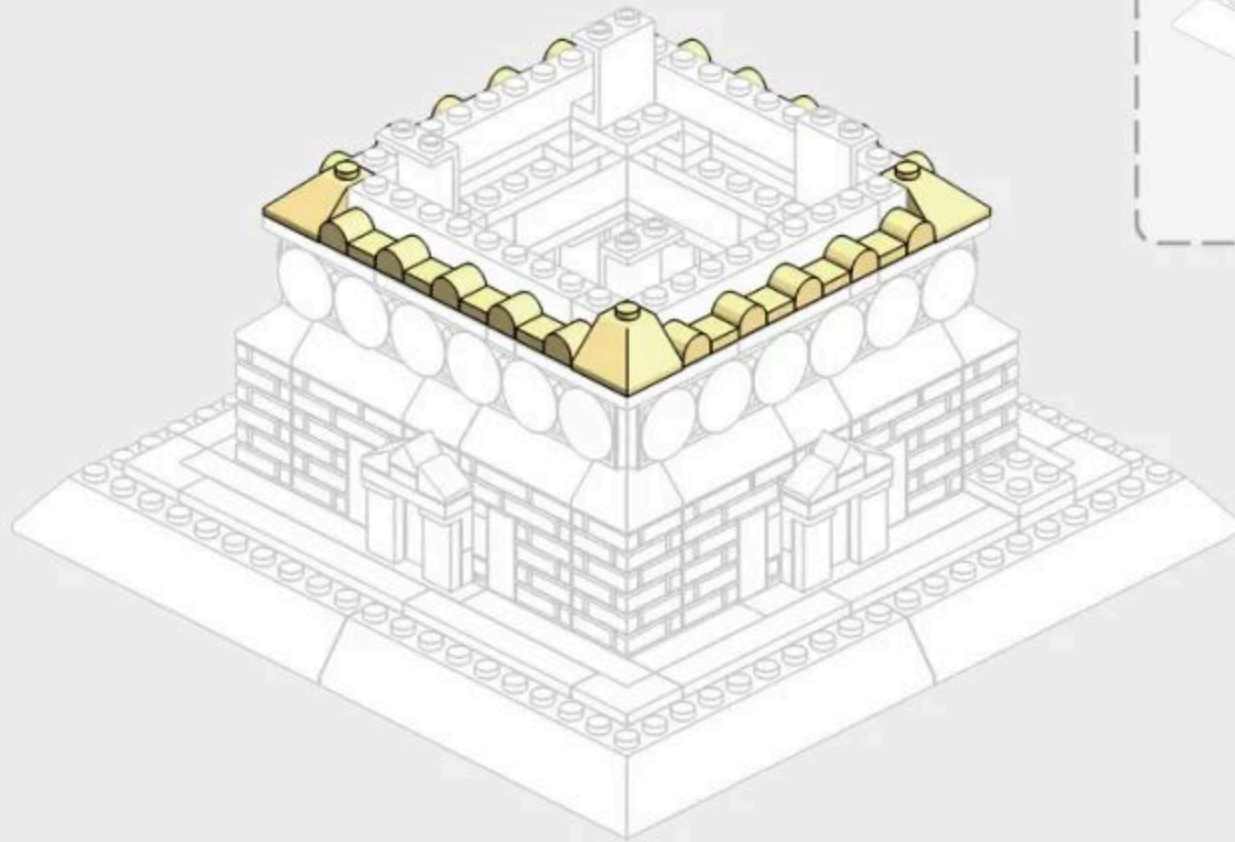

Back Side of Installation Drawing
安装图背面

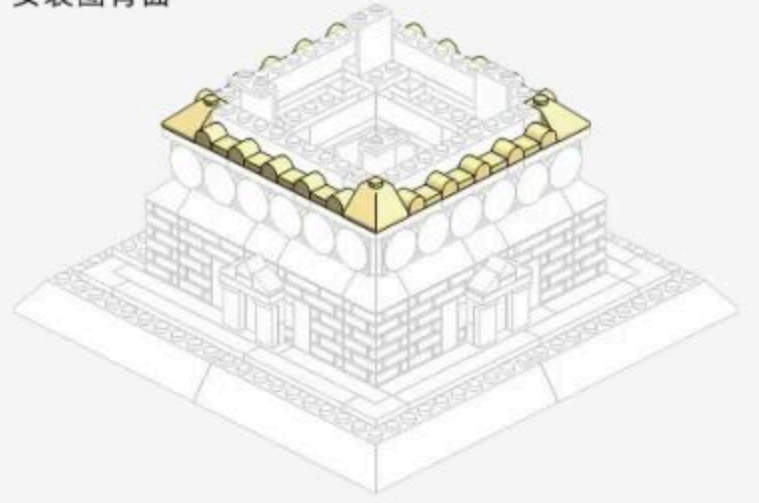

2-2



x4



x8



x8



x16

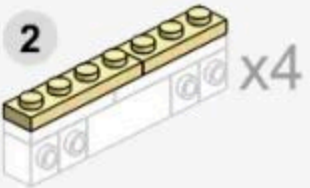
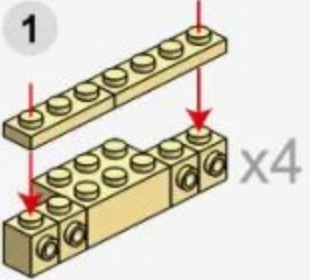
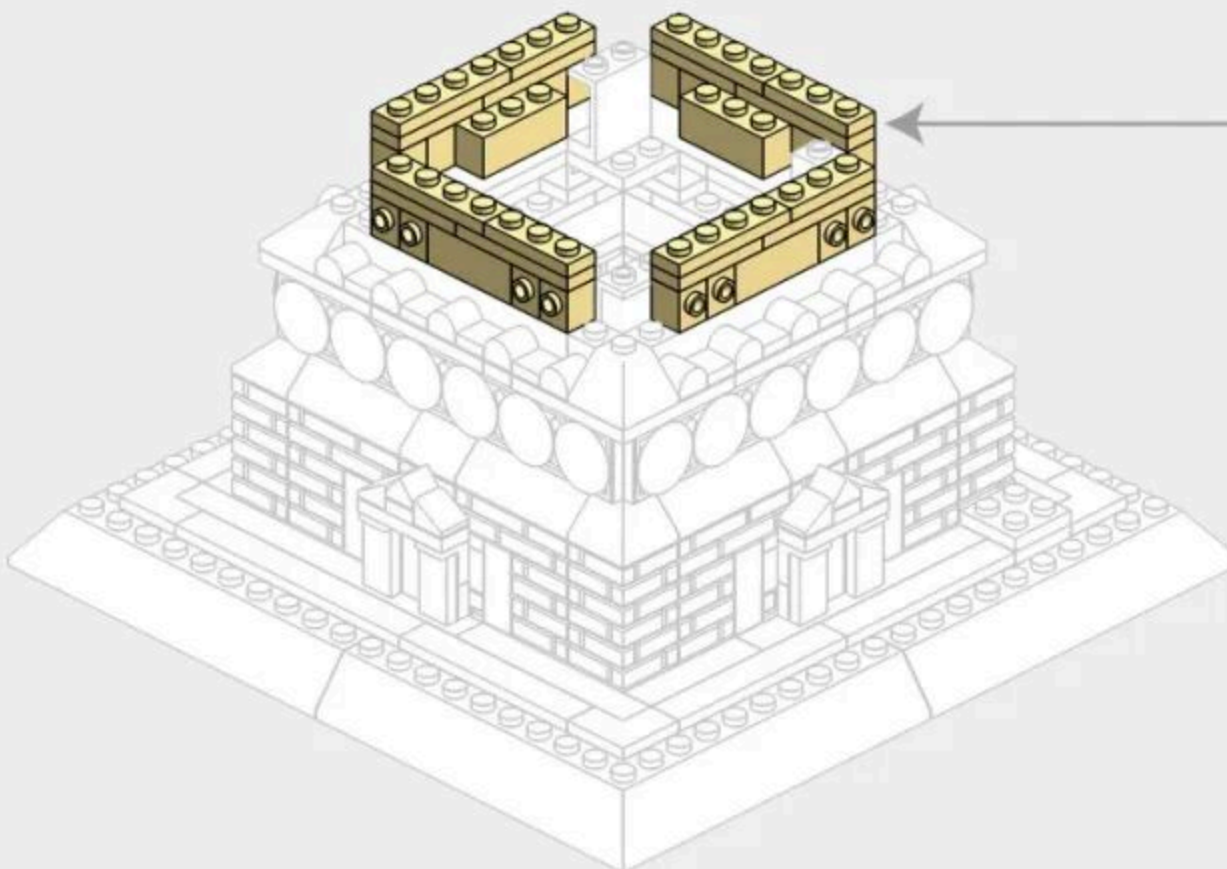

2-3

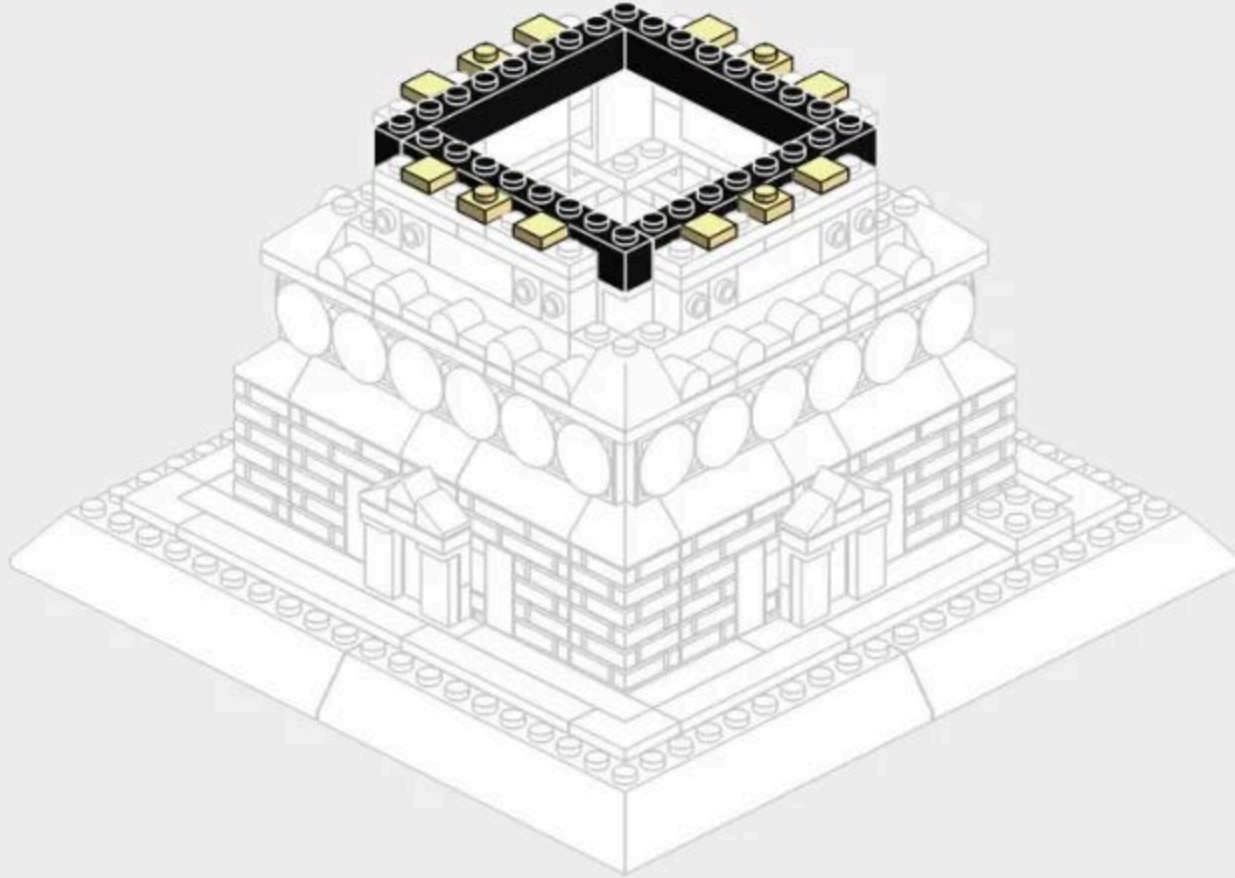
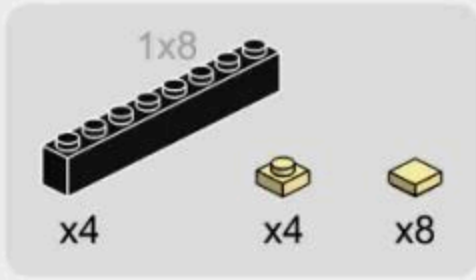

2-4

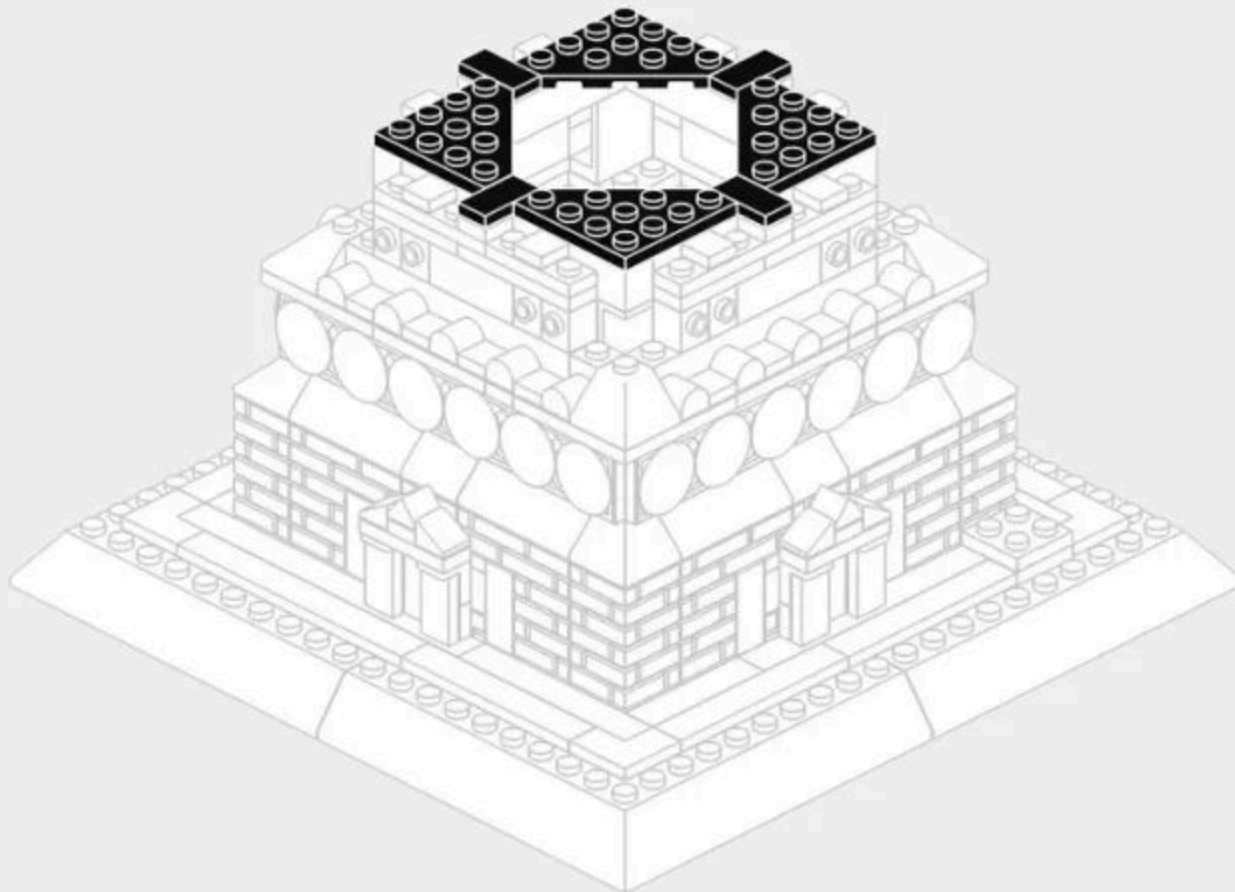

2-5

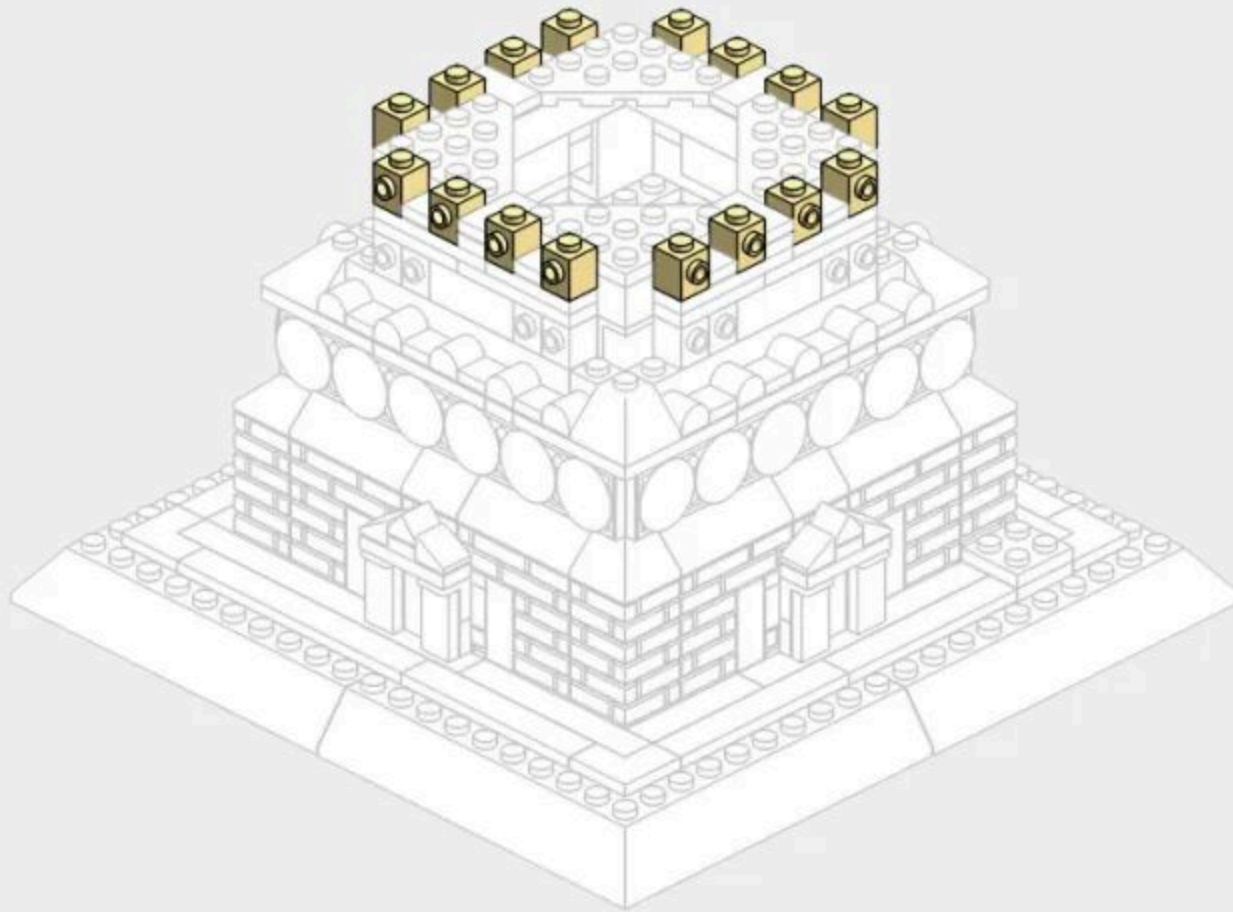

2-6

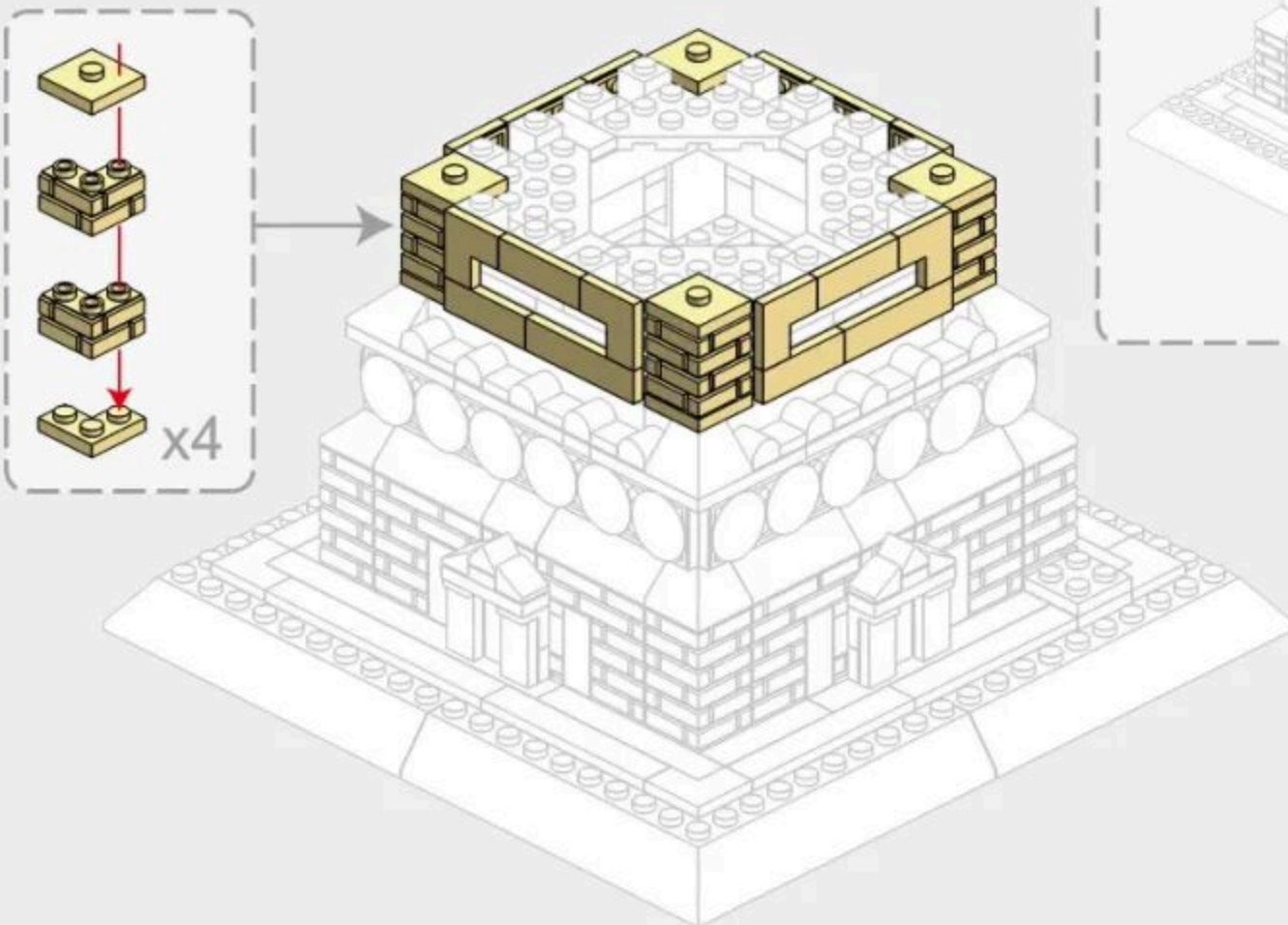
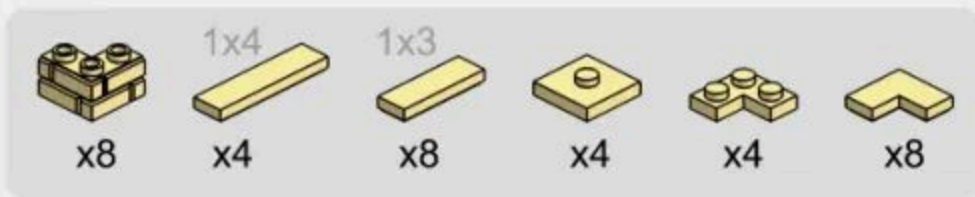

Back Side of Installation Drawing
安装图背面

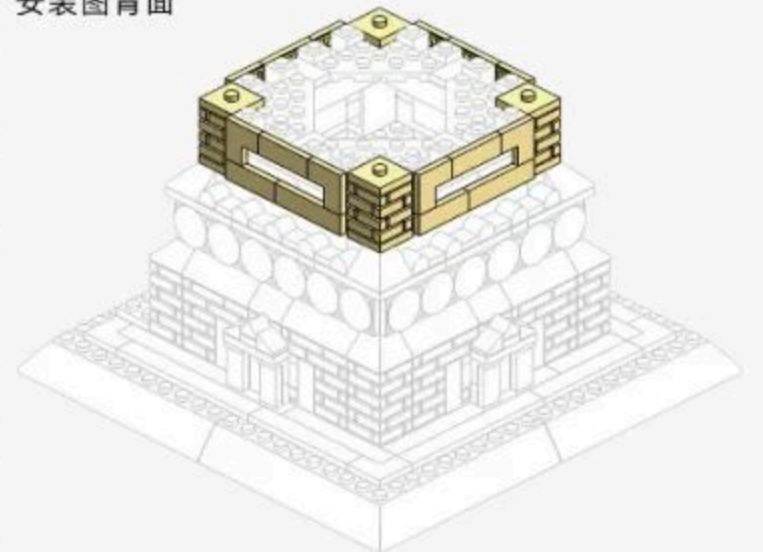

2-7

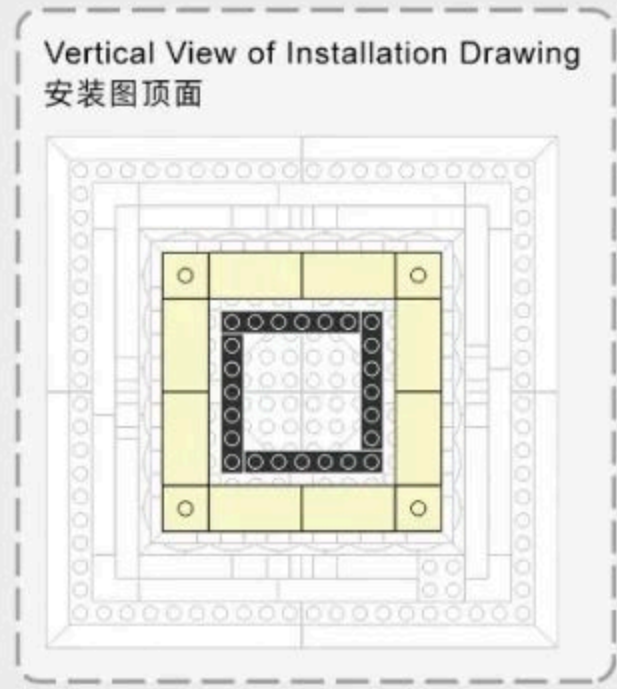
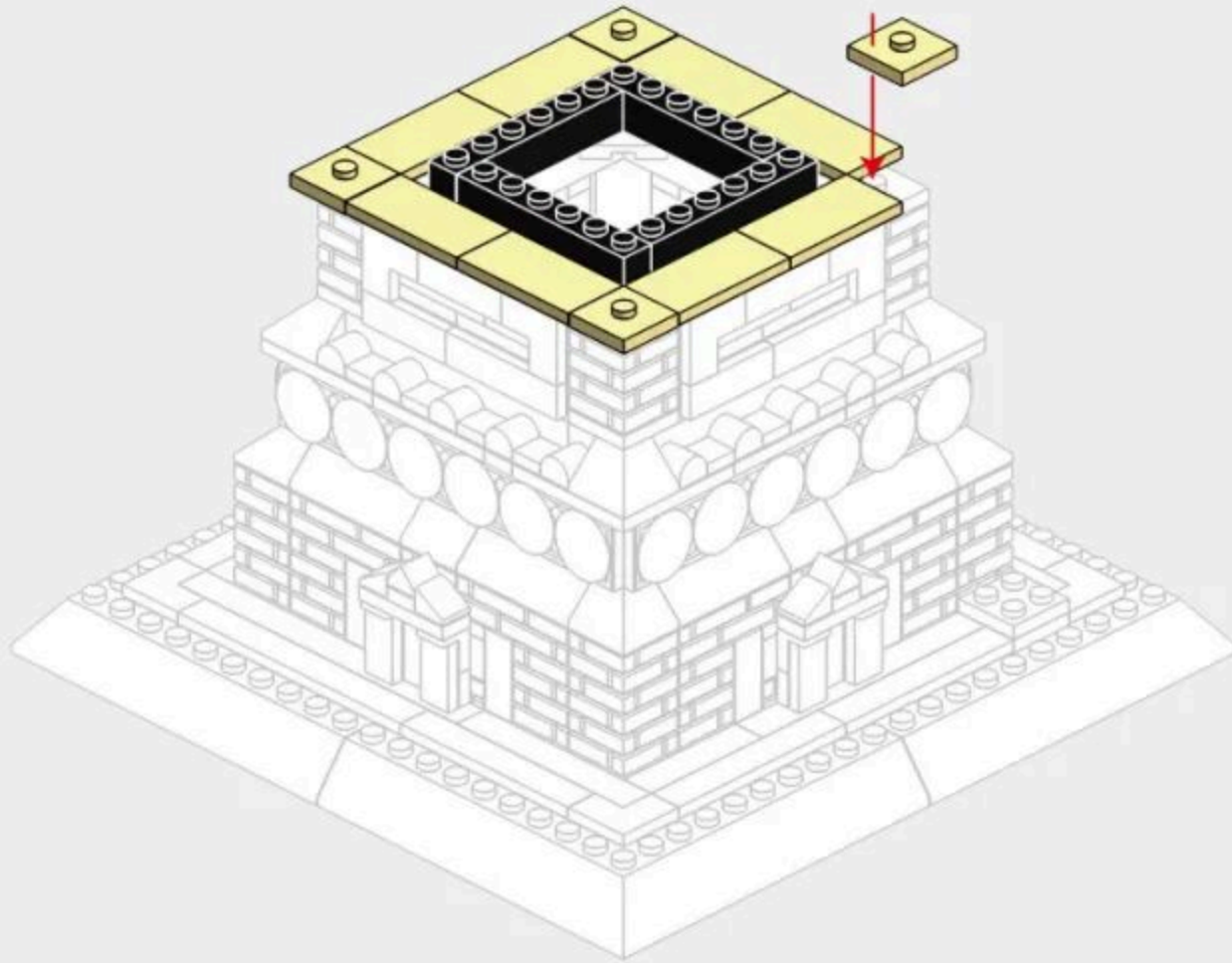
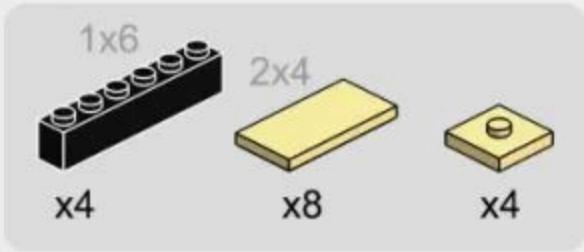

2-8

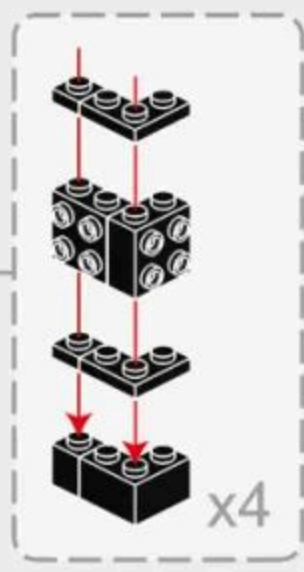
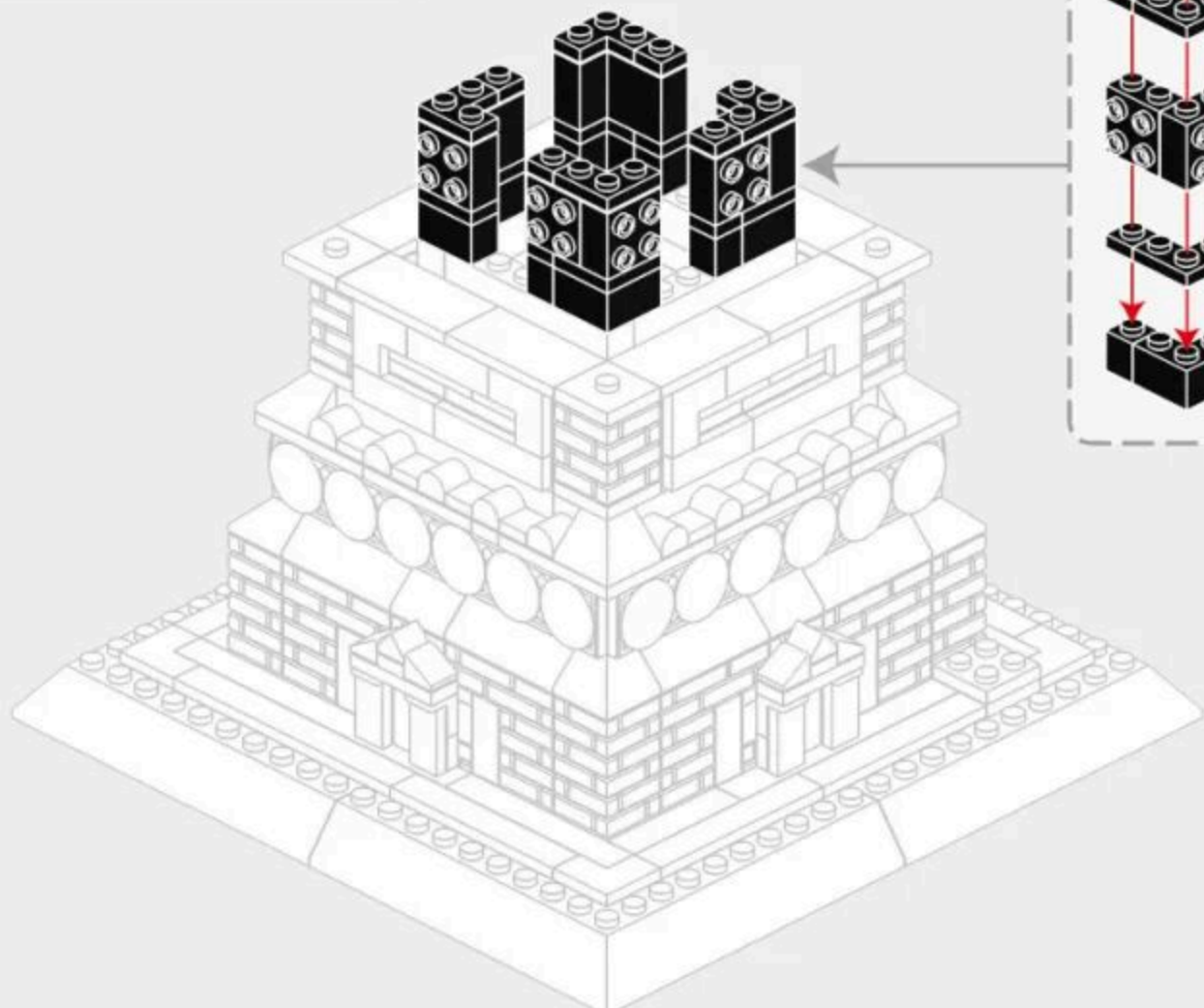

2-9

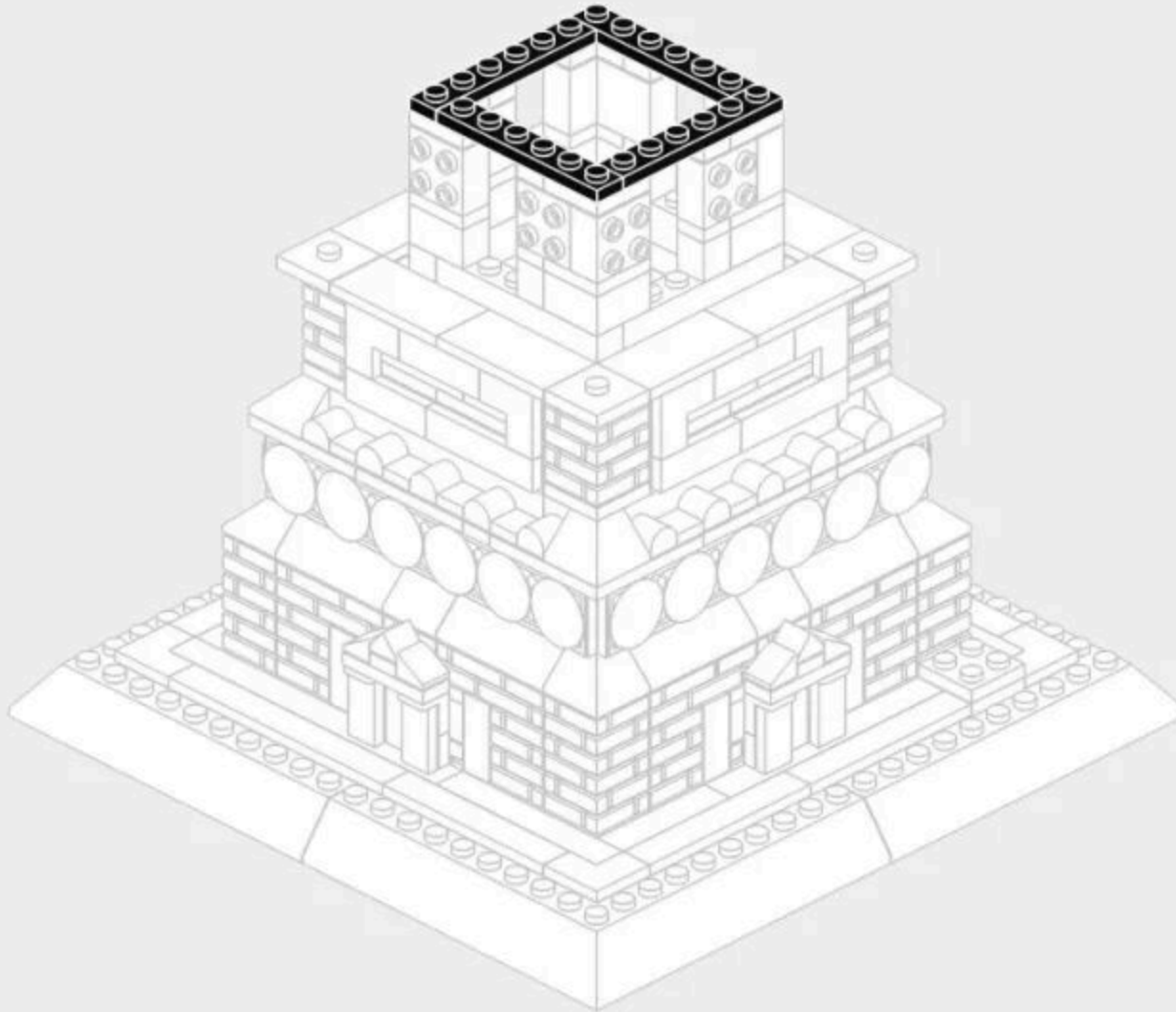

2-10

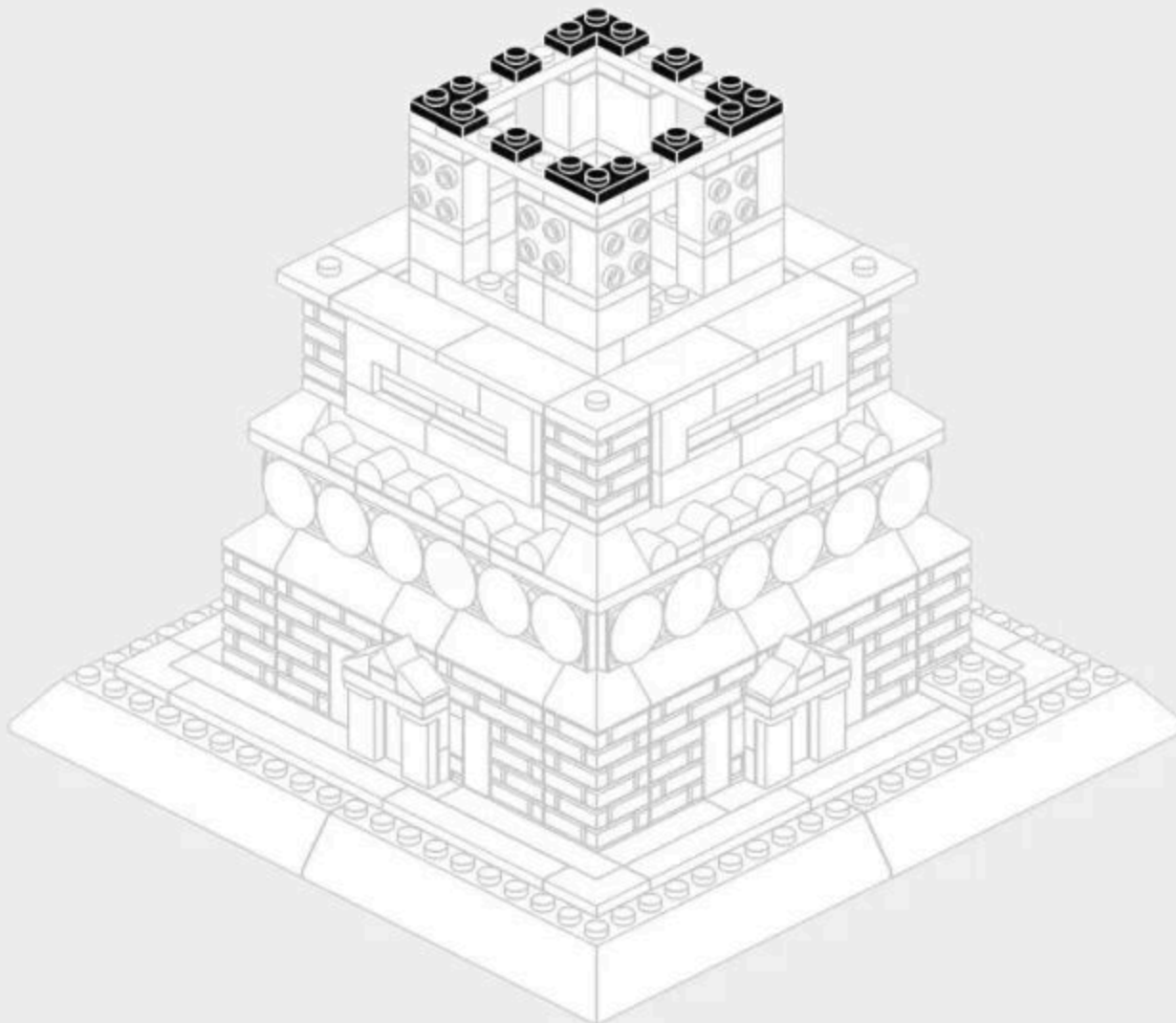



272PCS

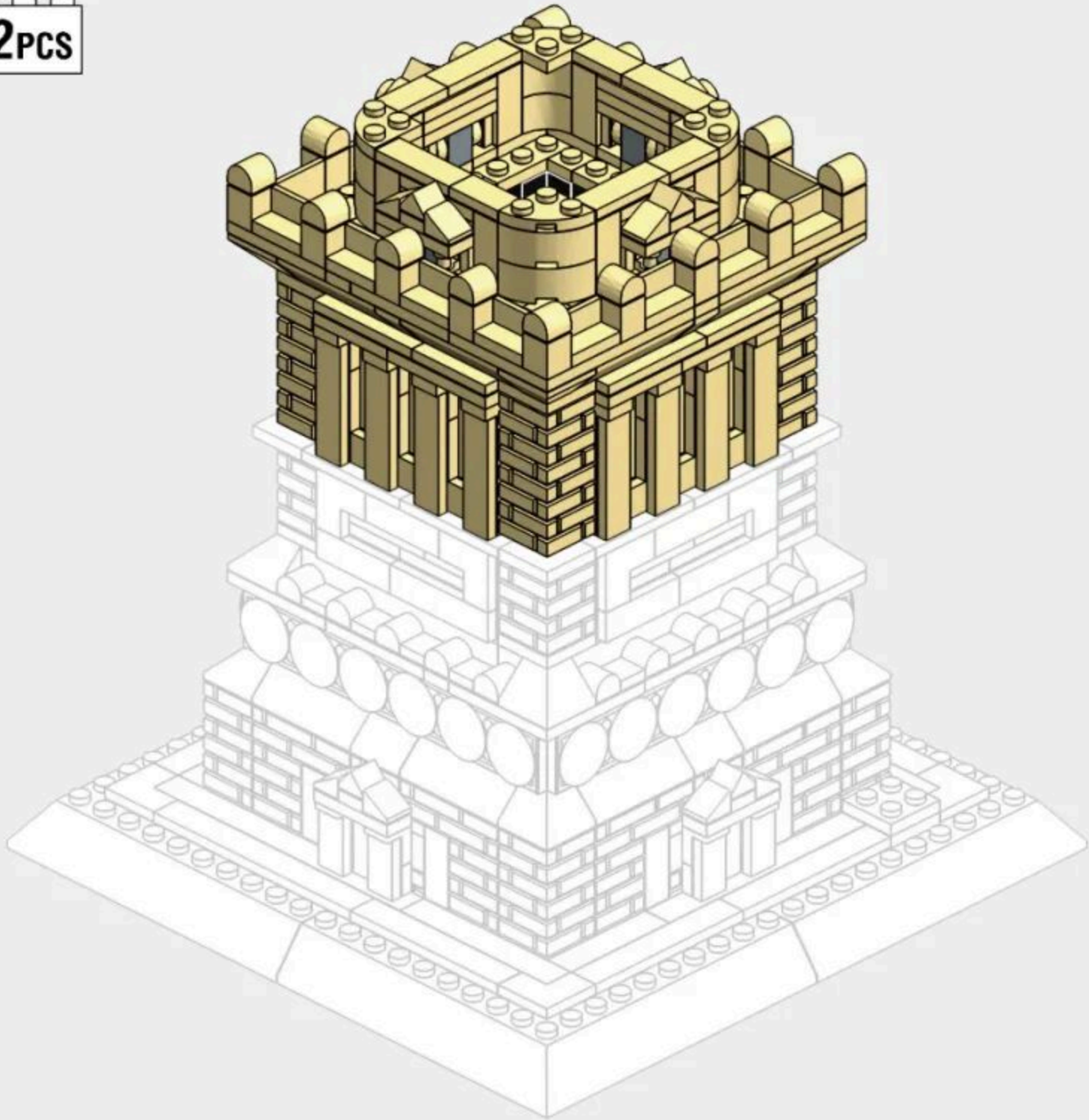

3-1

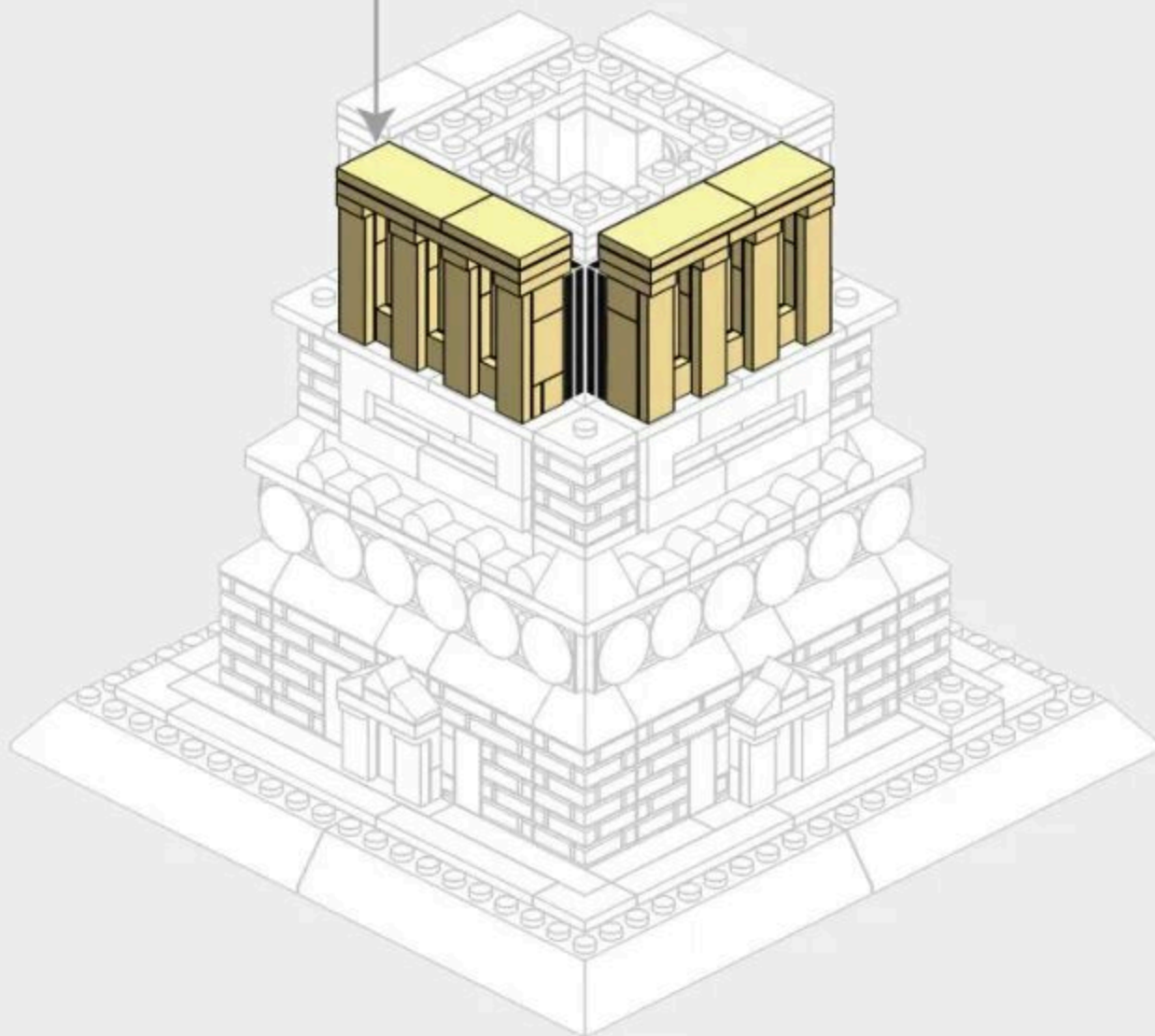
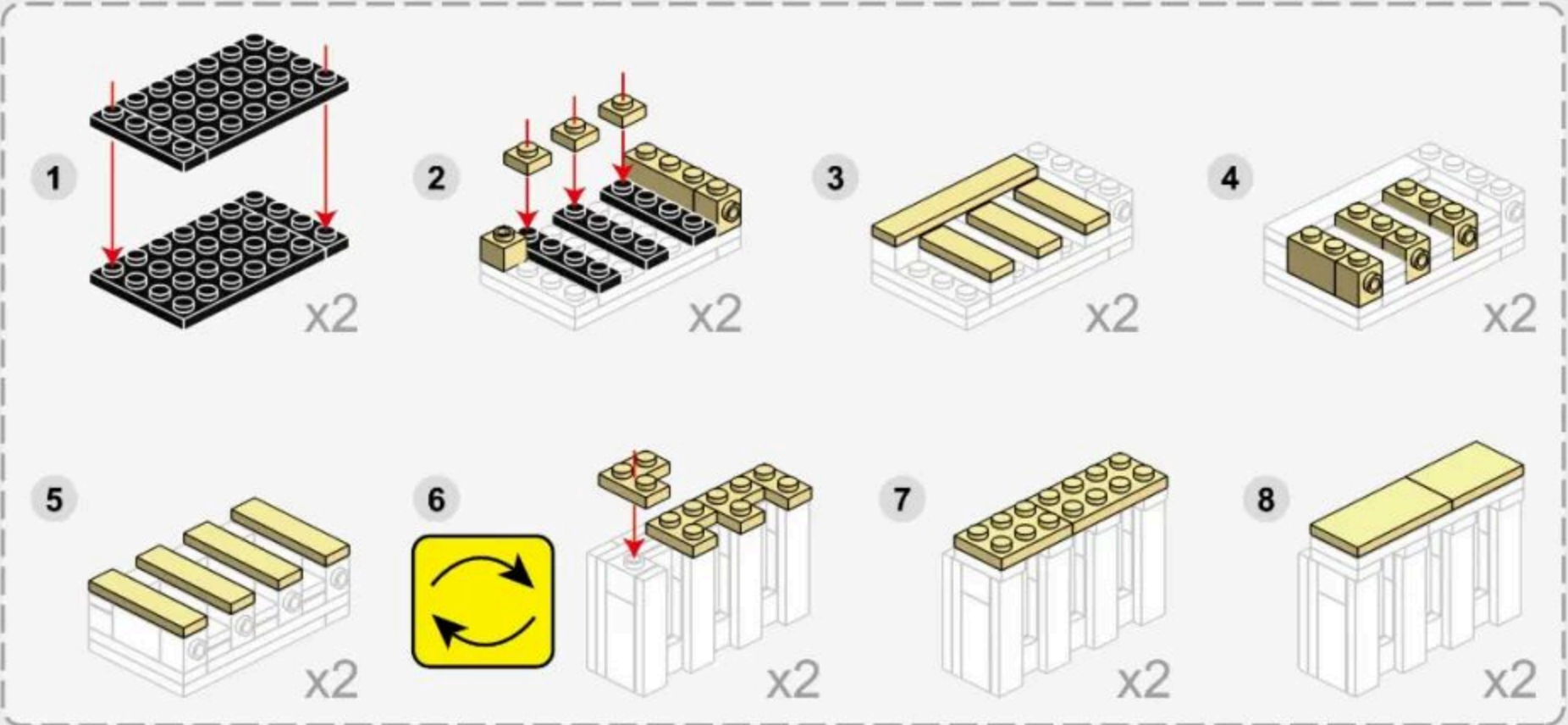

3-4

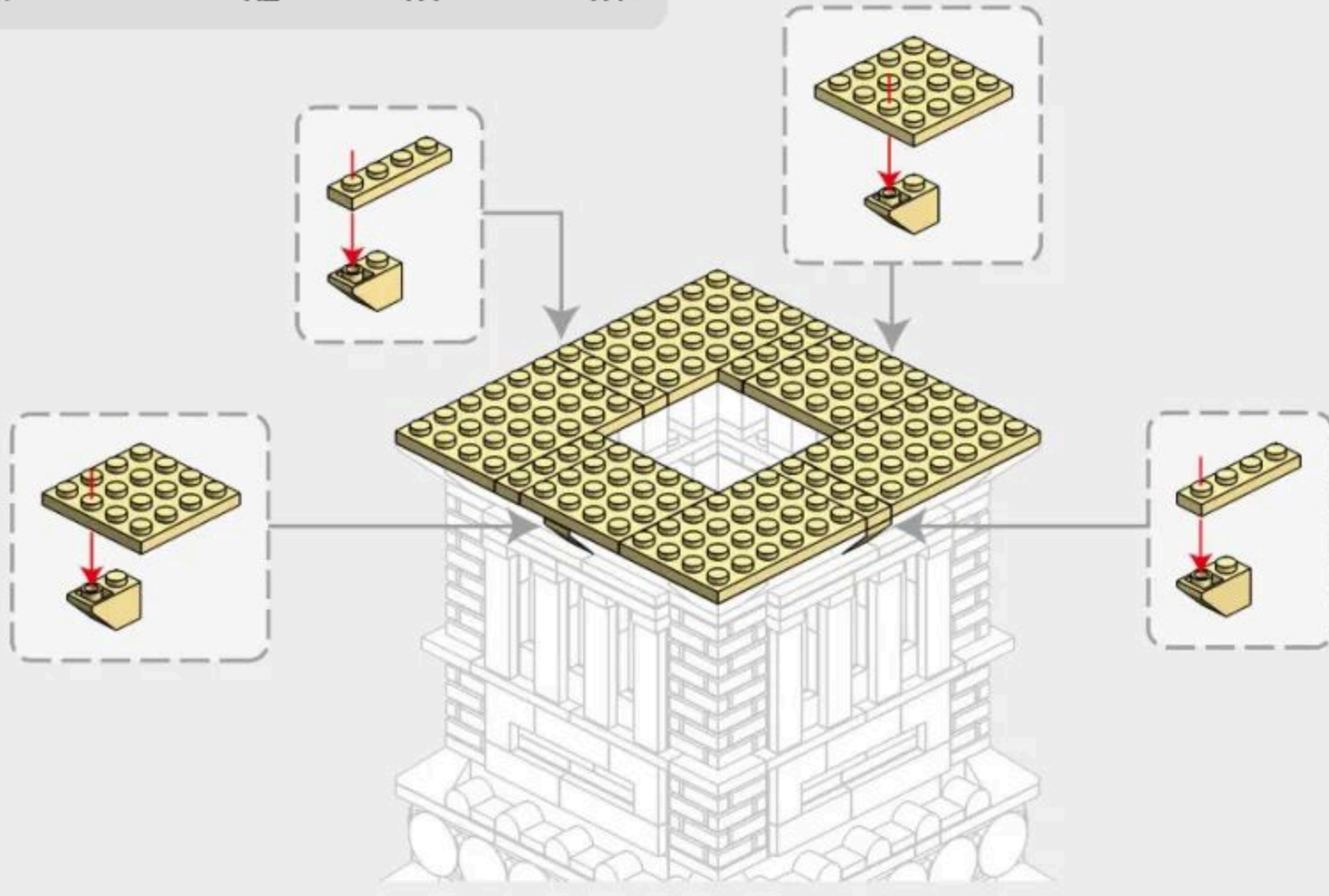
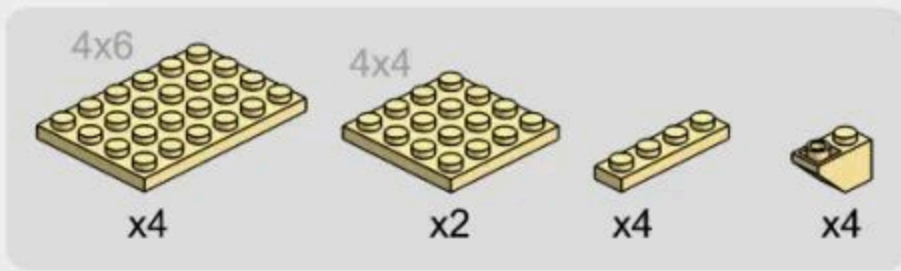

3-5

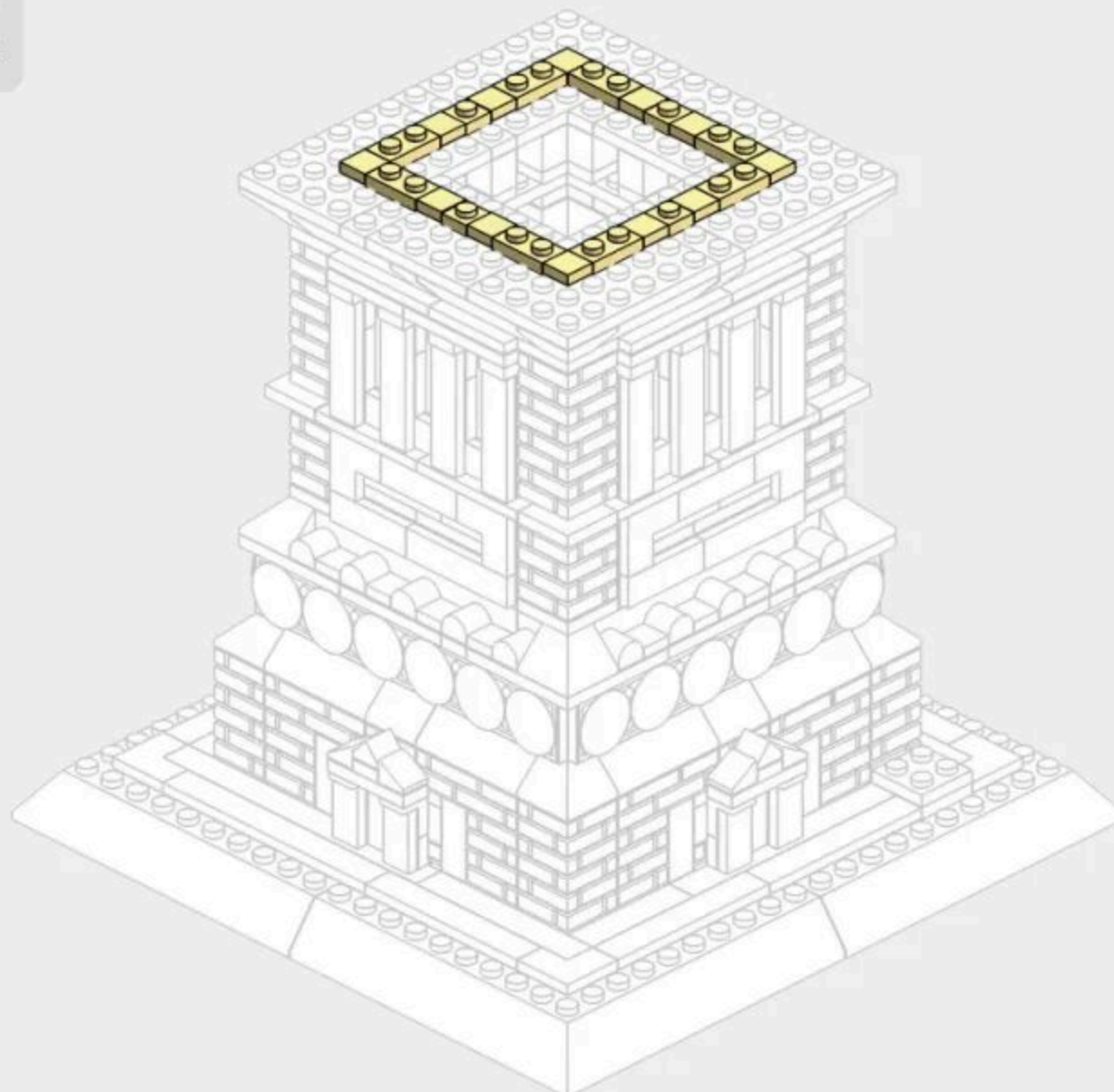

3-6

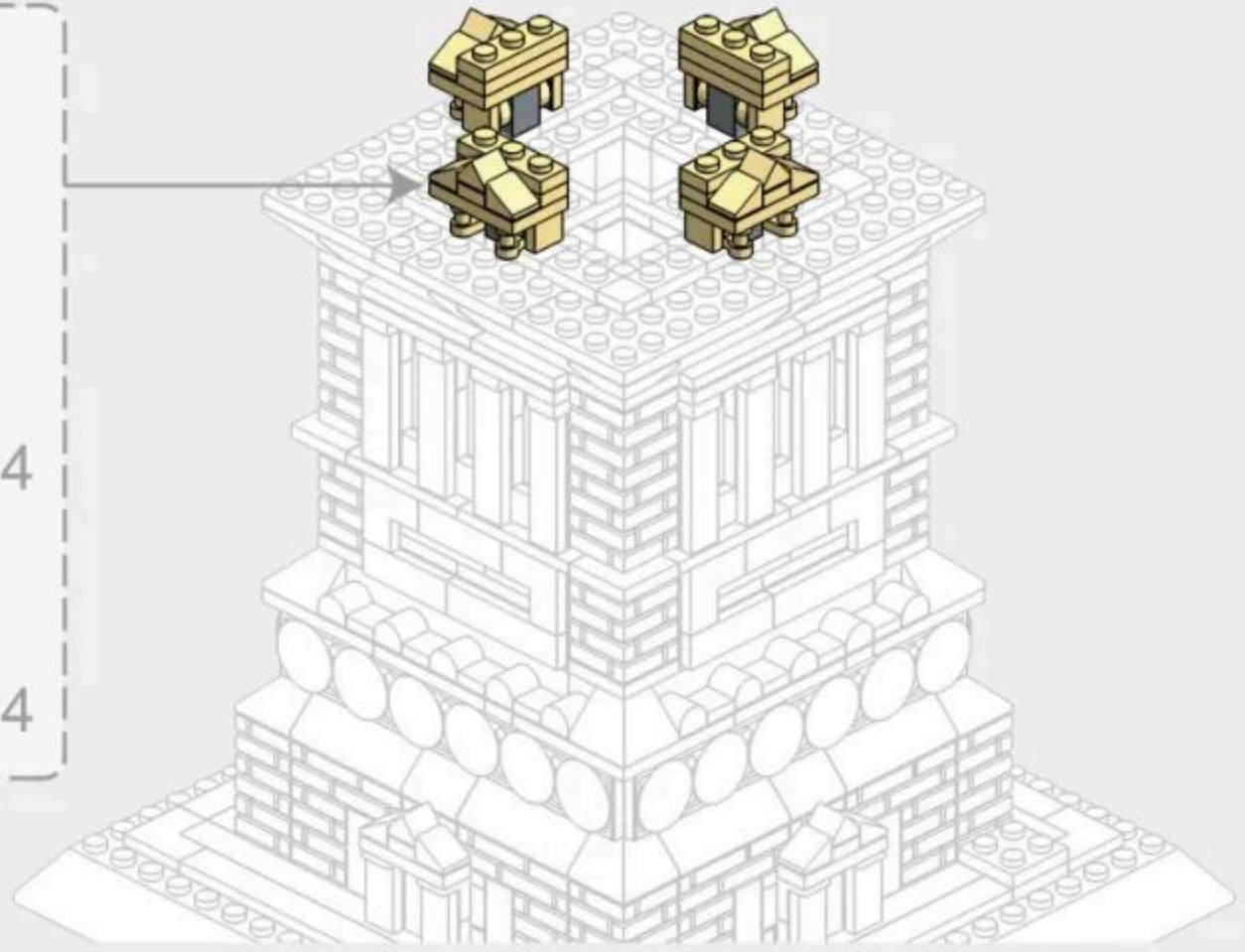
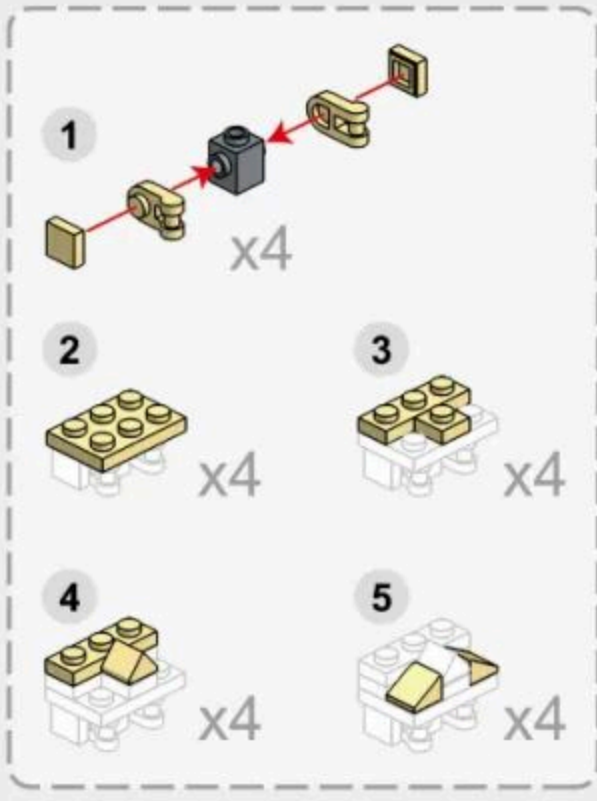

3-7

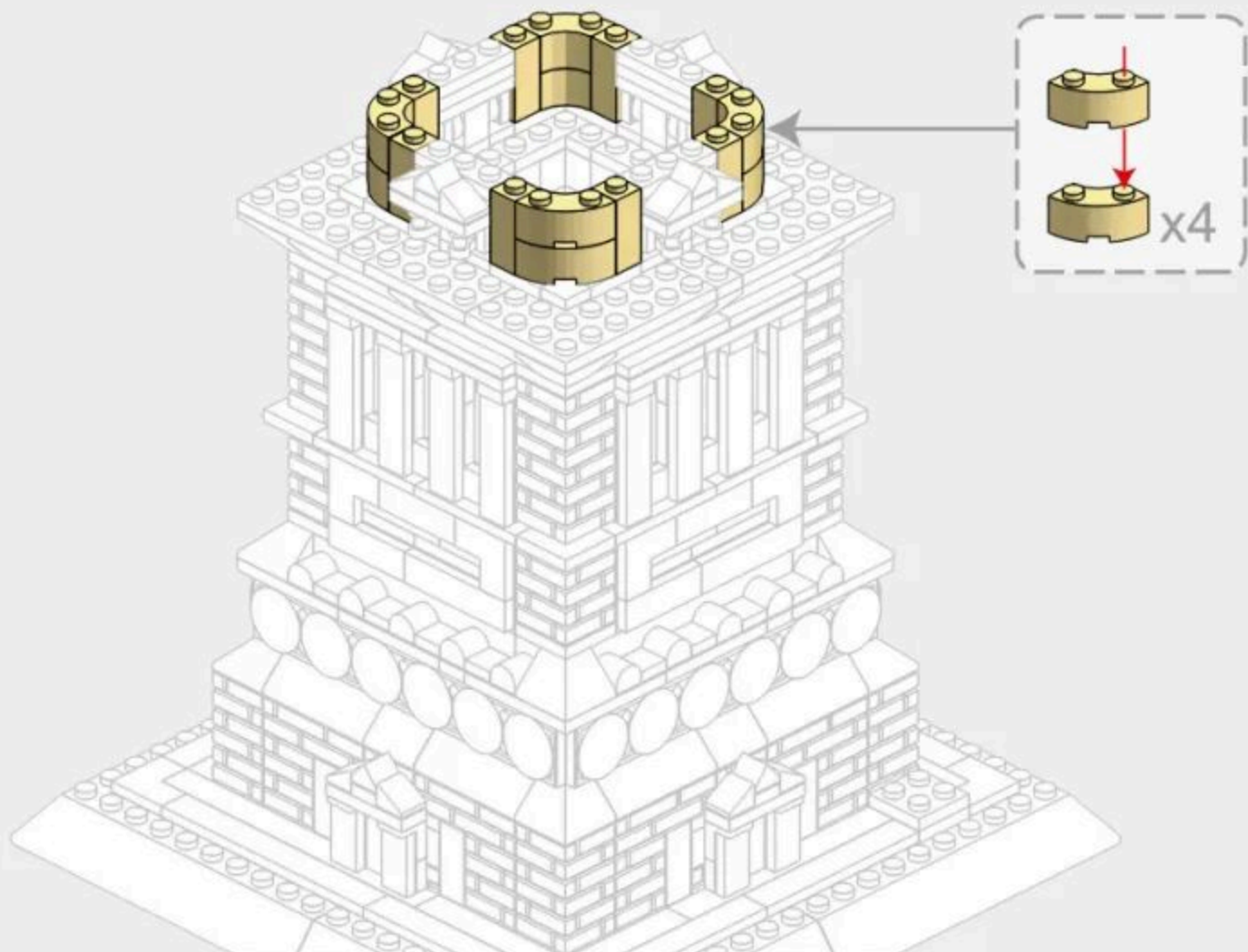

3-8

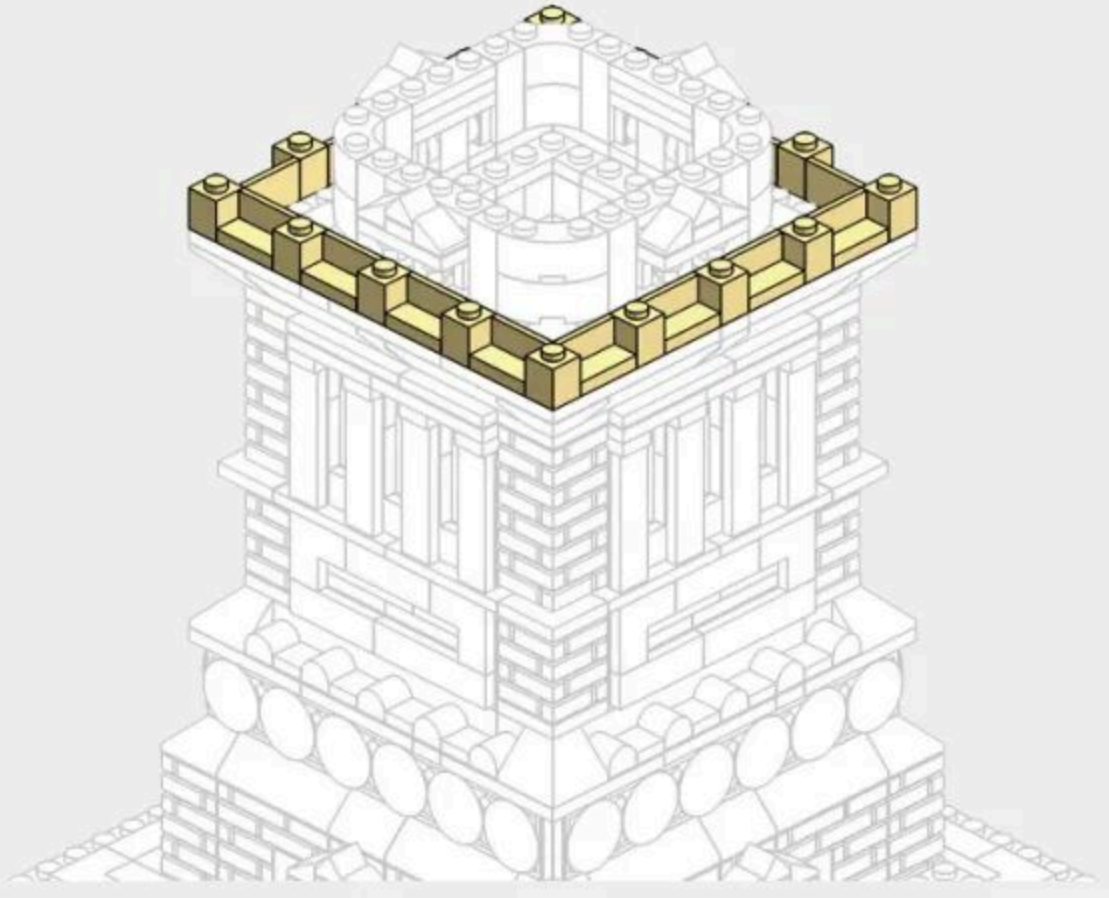

Back Side of Installation Drawing
安装图背面

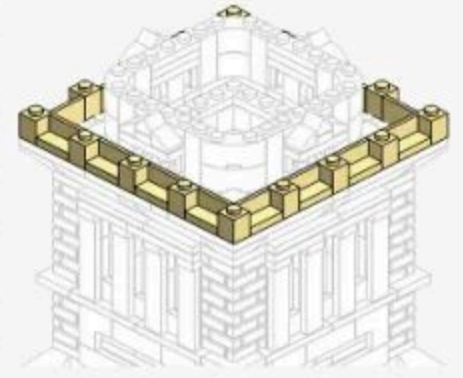

3-9

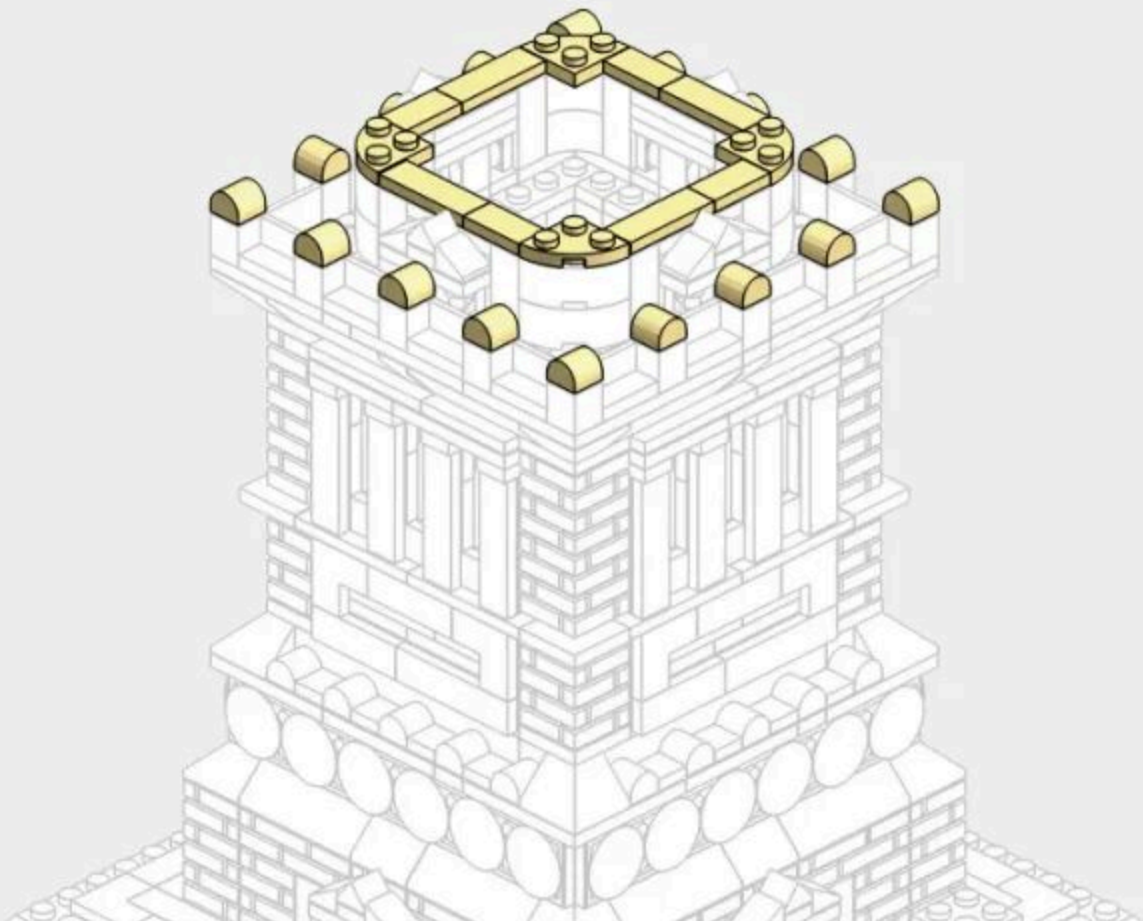

Back Side of Installation Drawing
安装图背面

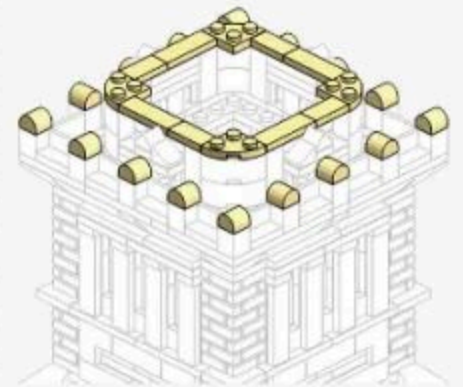



284PCS

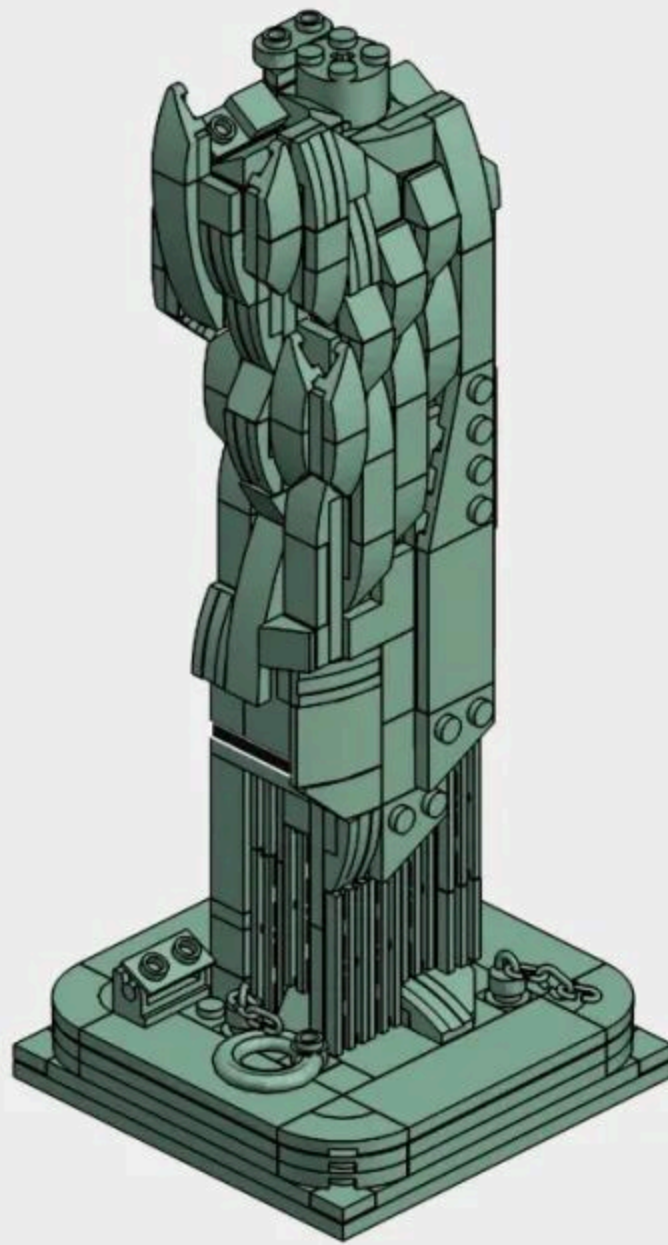

4-1

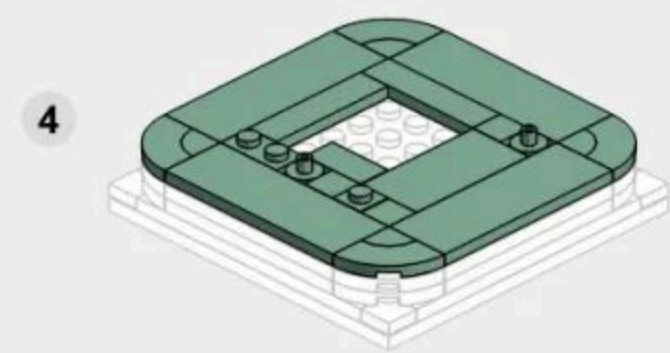
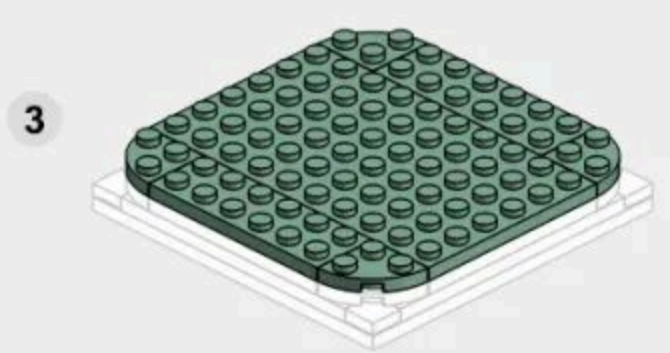
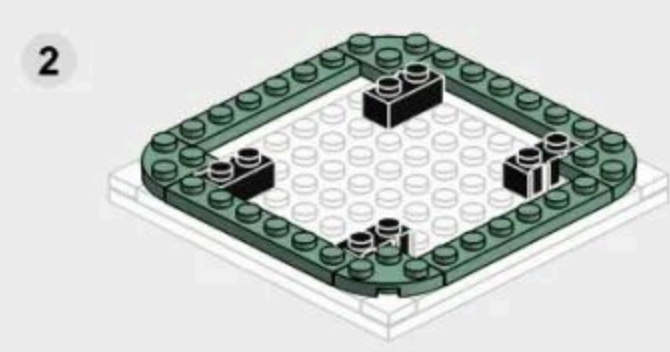
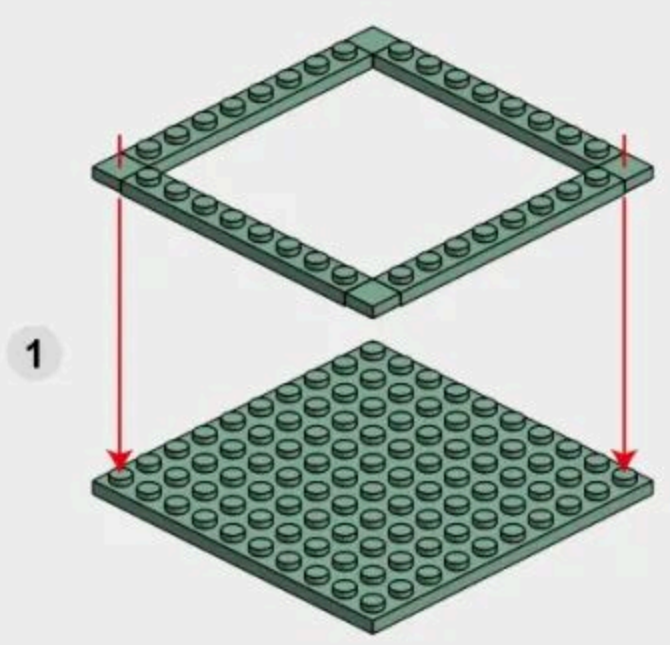
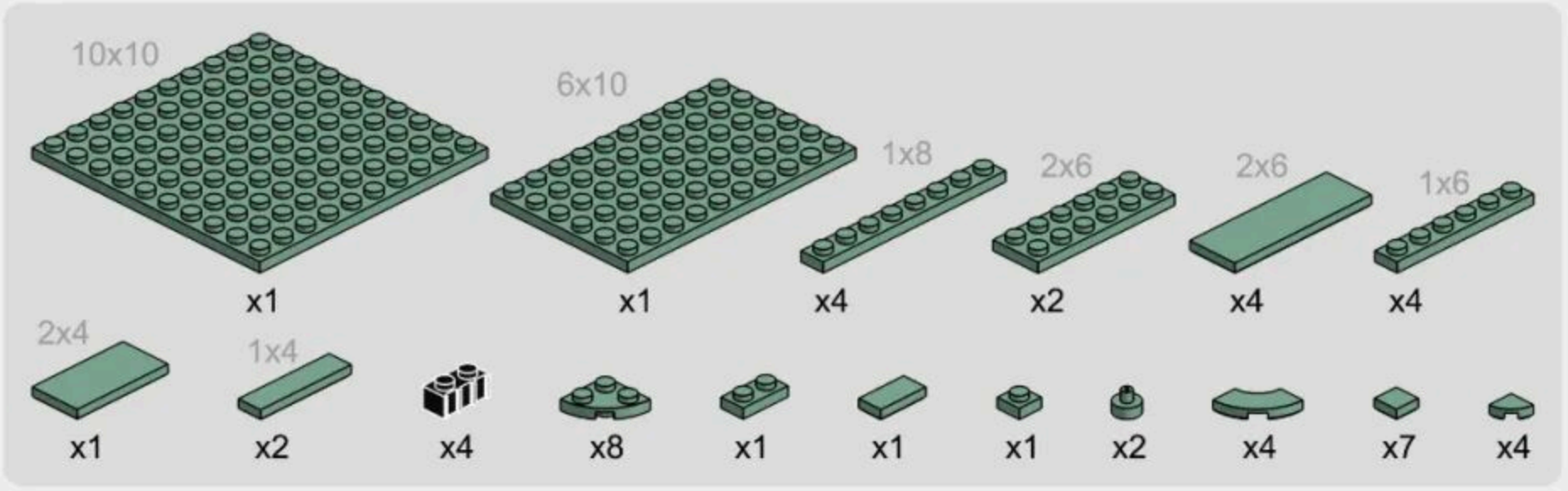

4-5

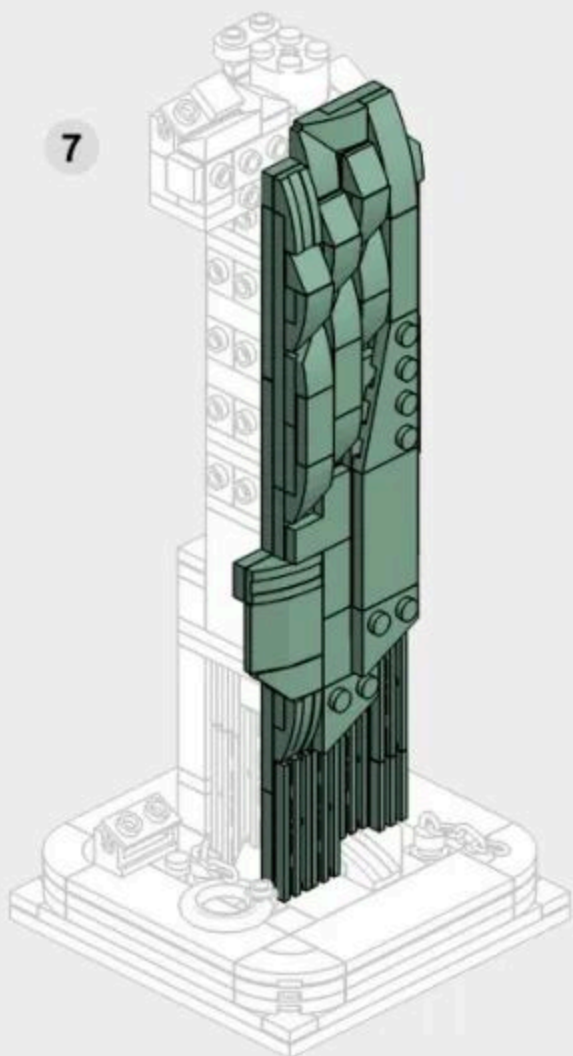
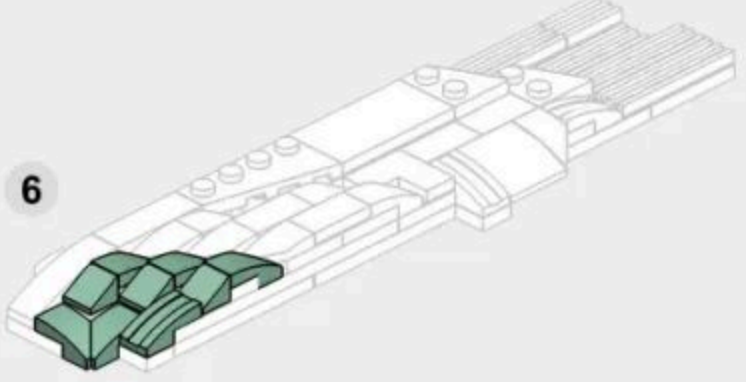
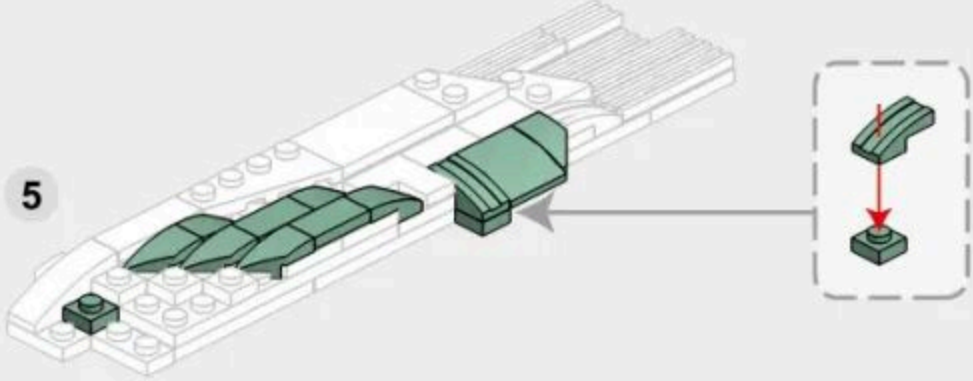
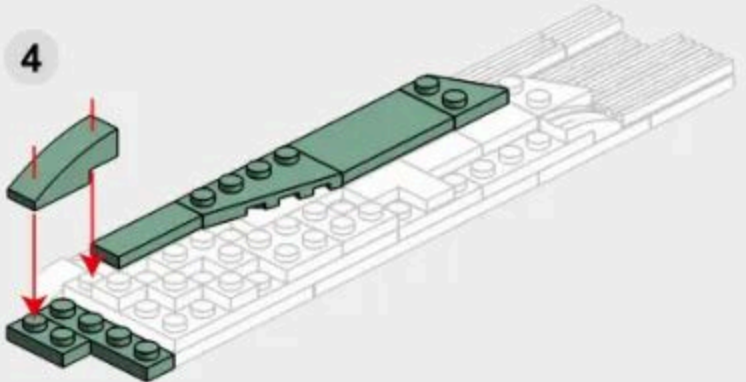
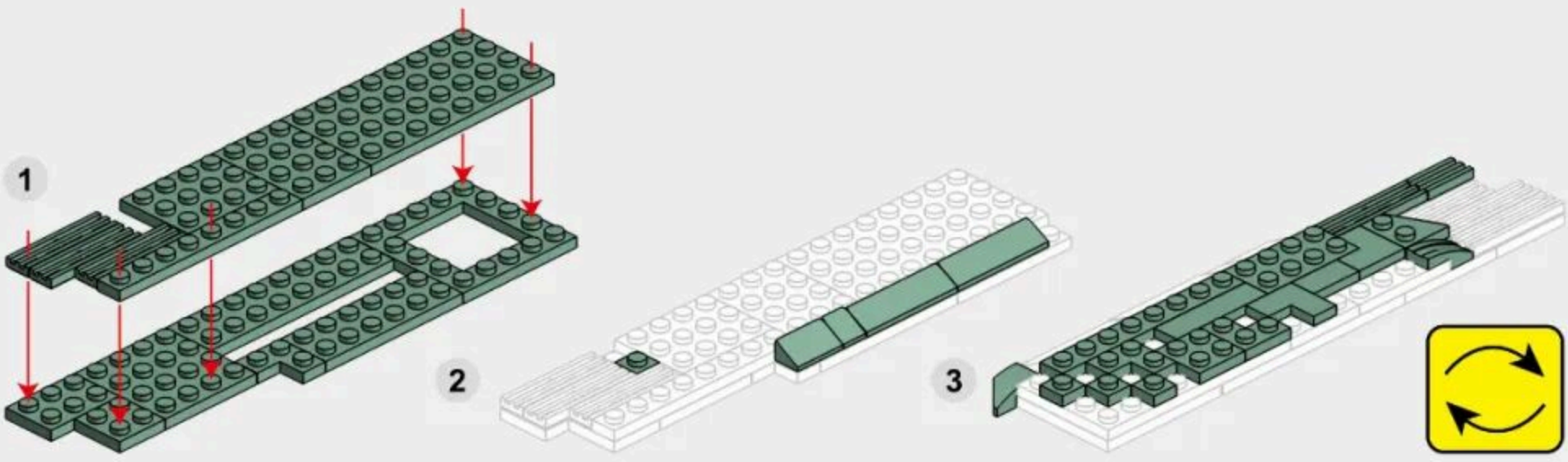
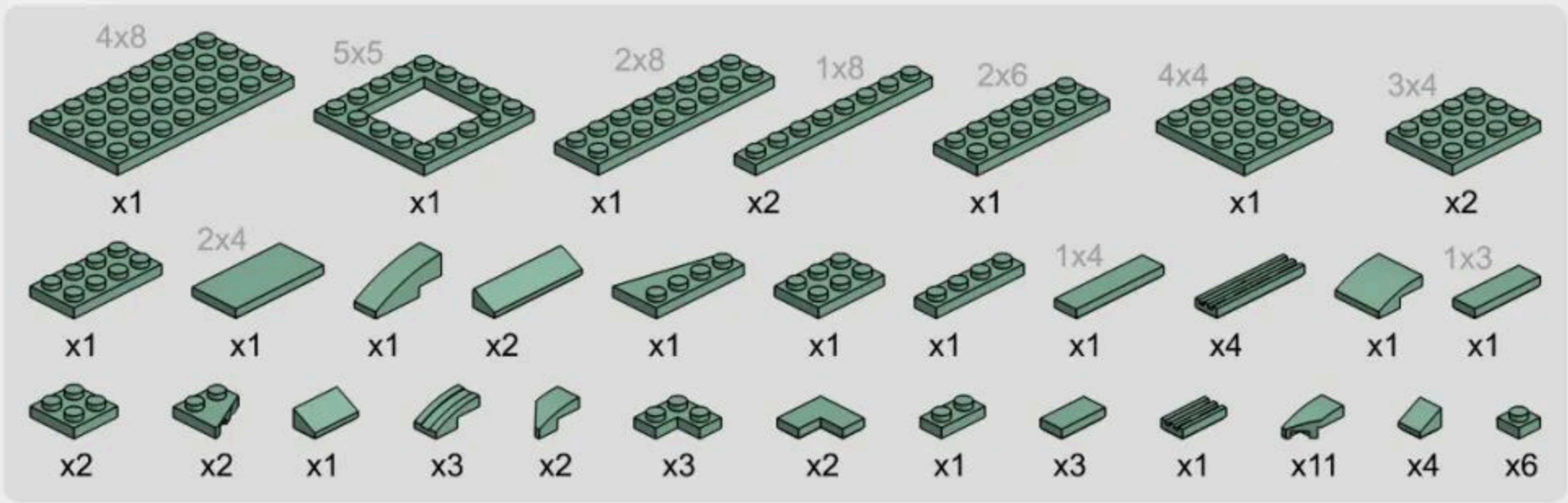

4-6

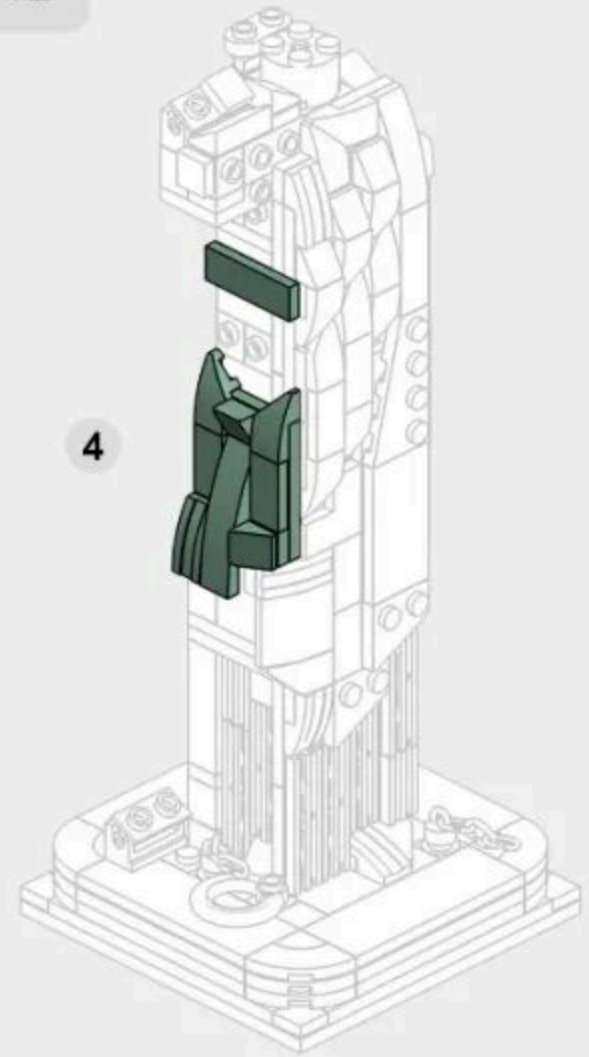
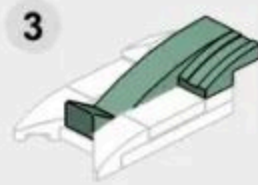
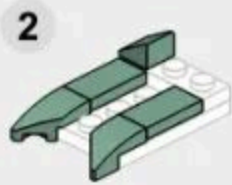
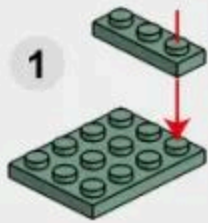
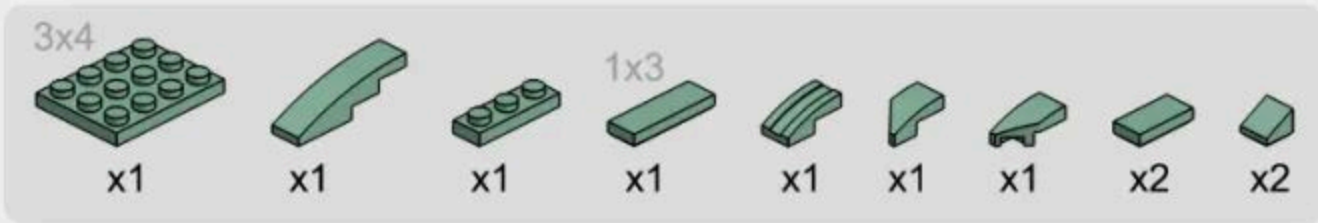

4-7

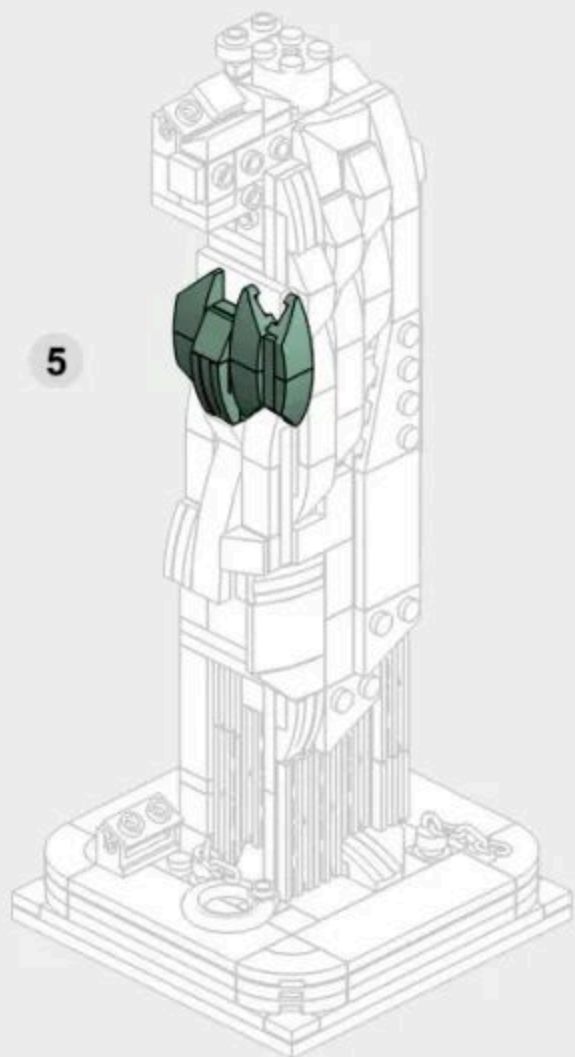
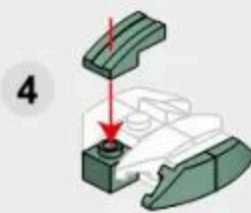
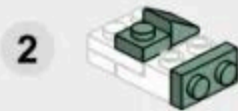
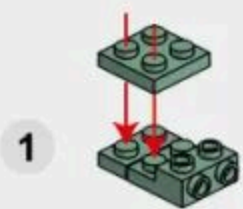
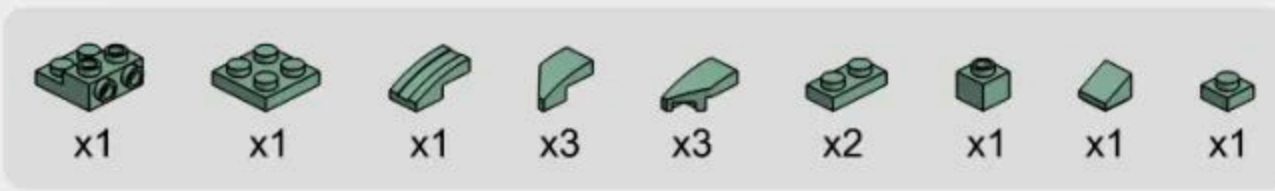

4-8

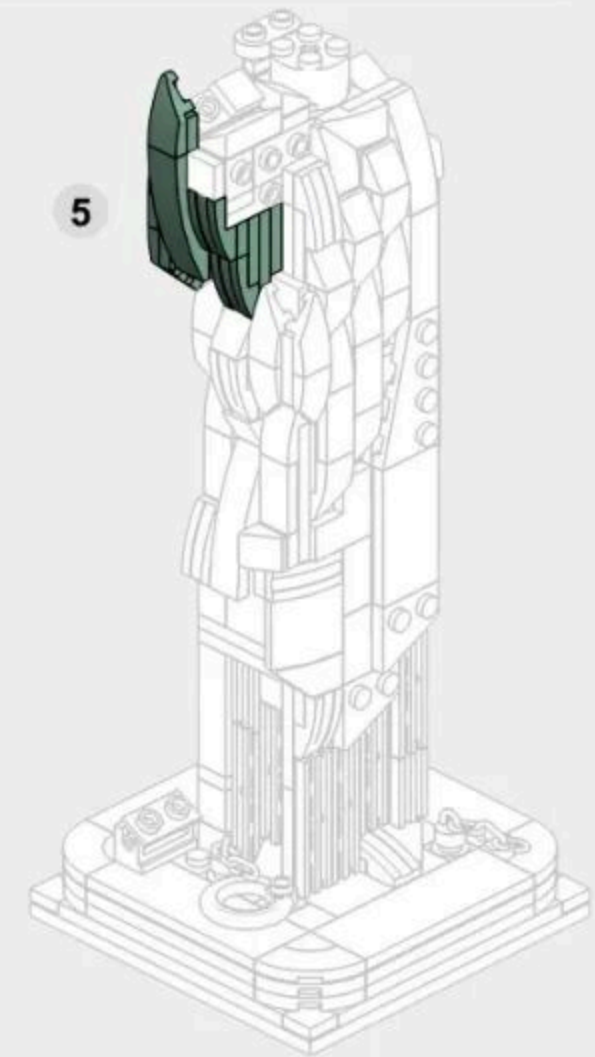
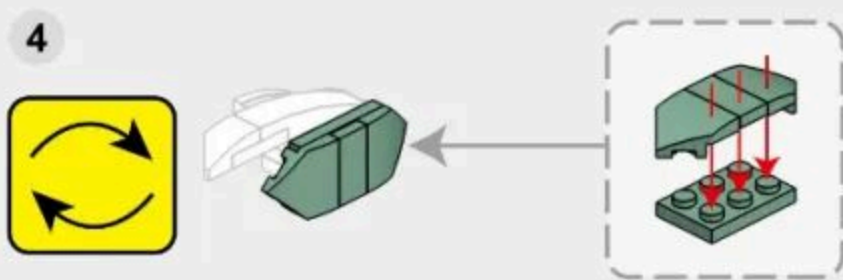
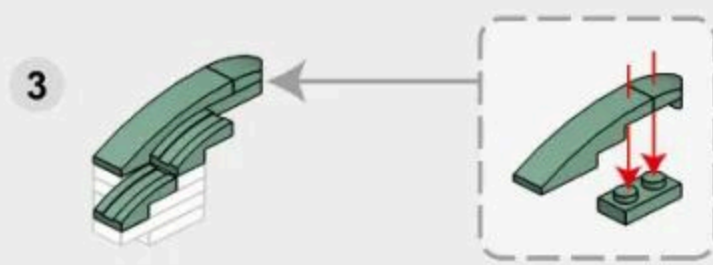
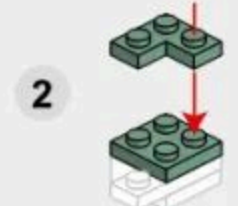
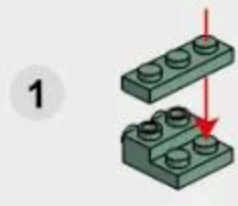
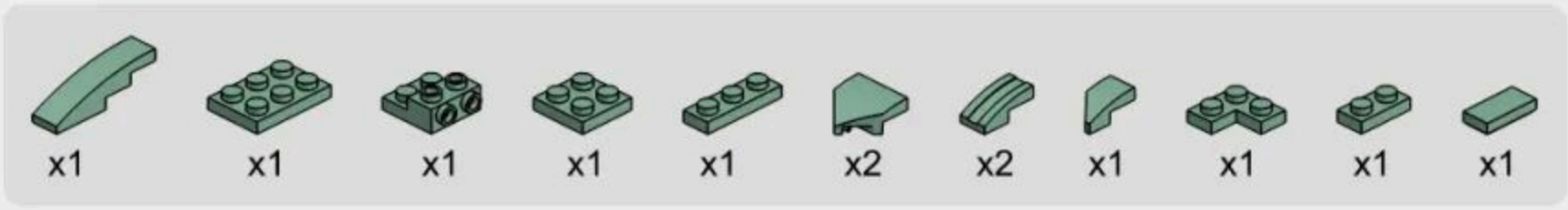

4-9

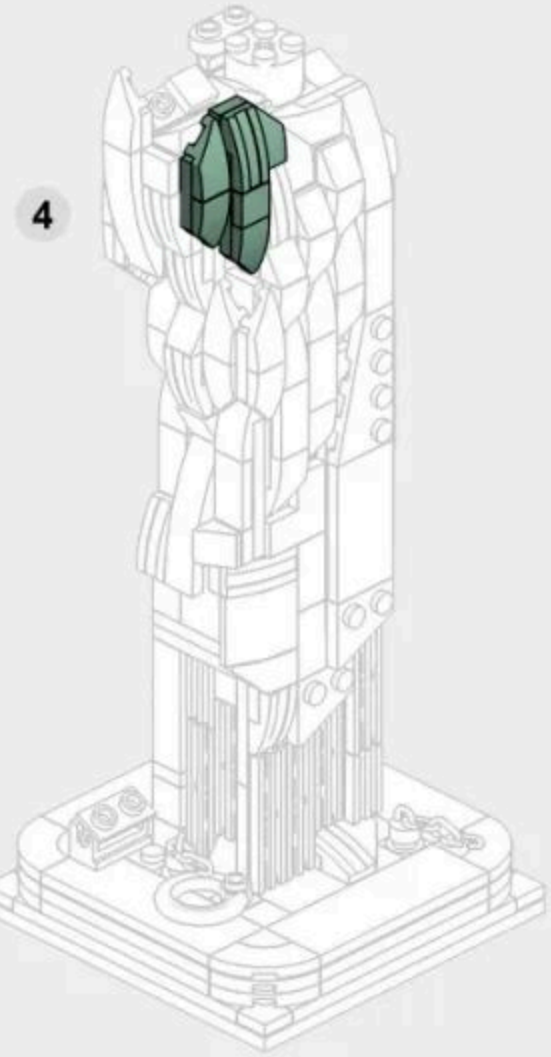
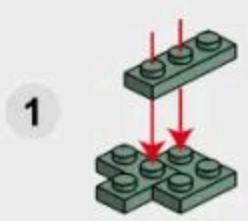



285PCS

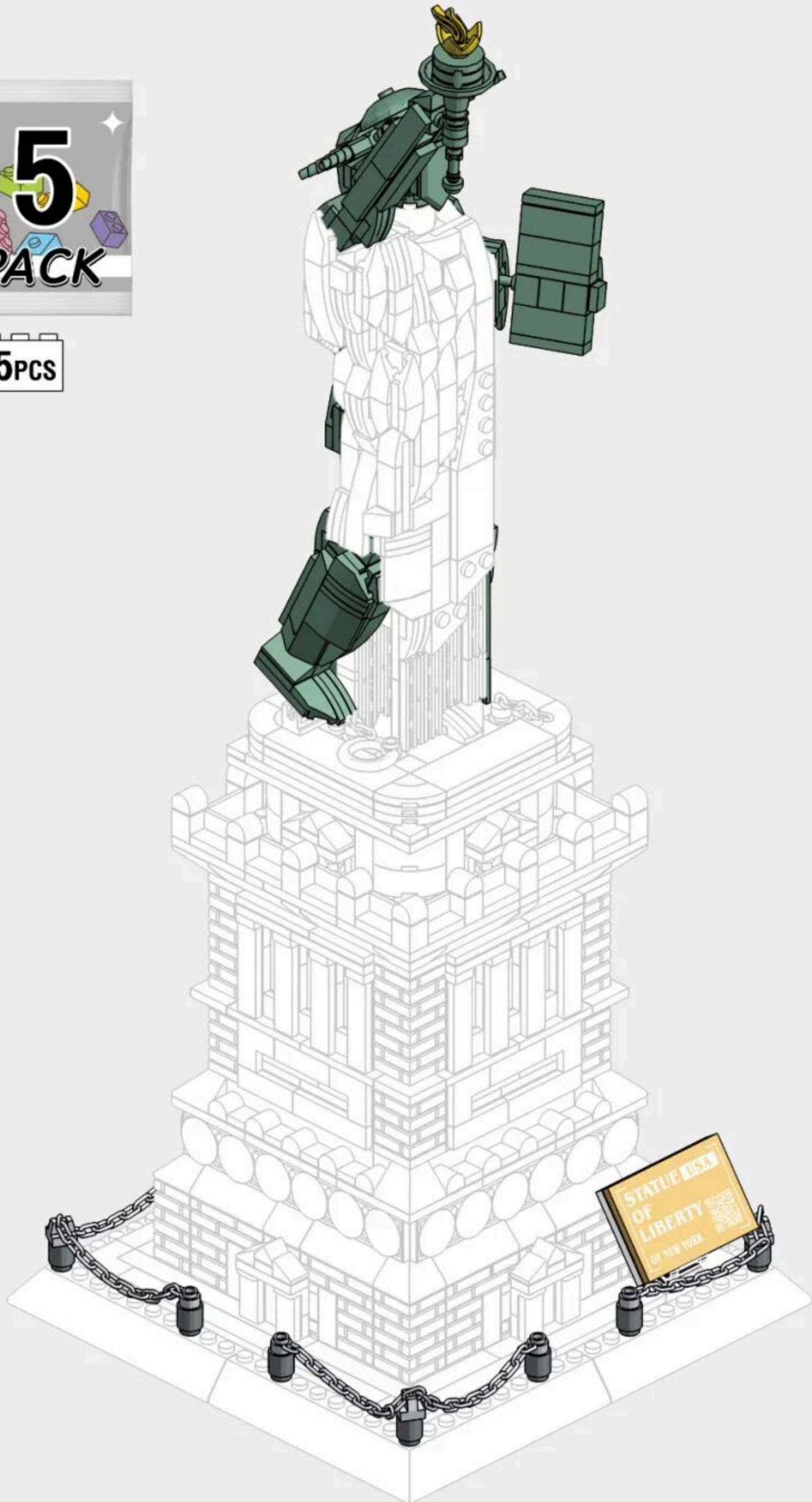



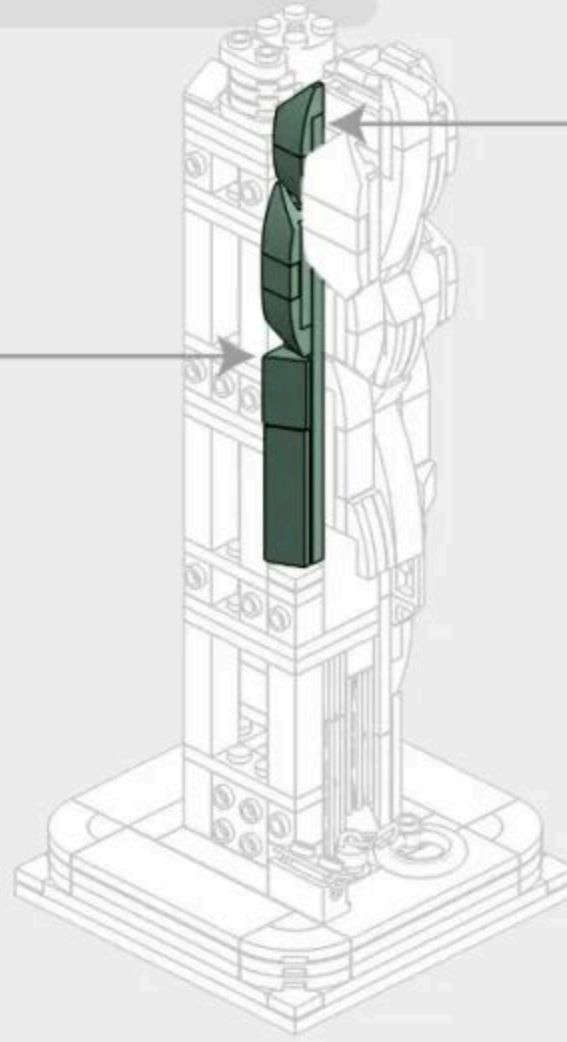
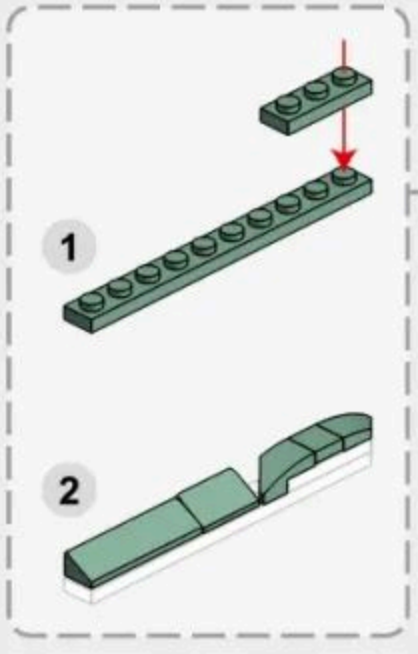
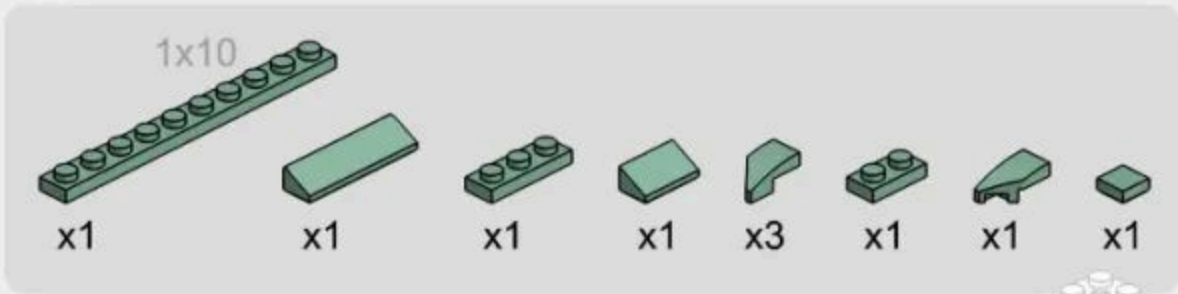



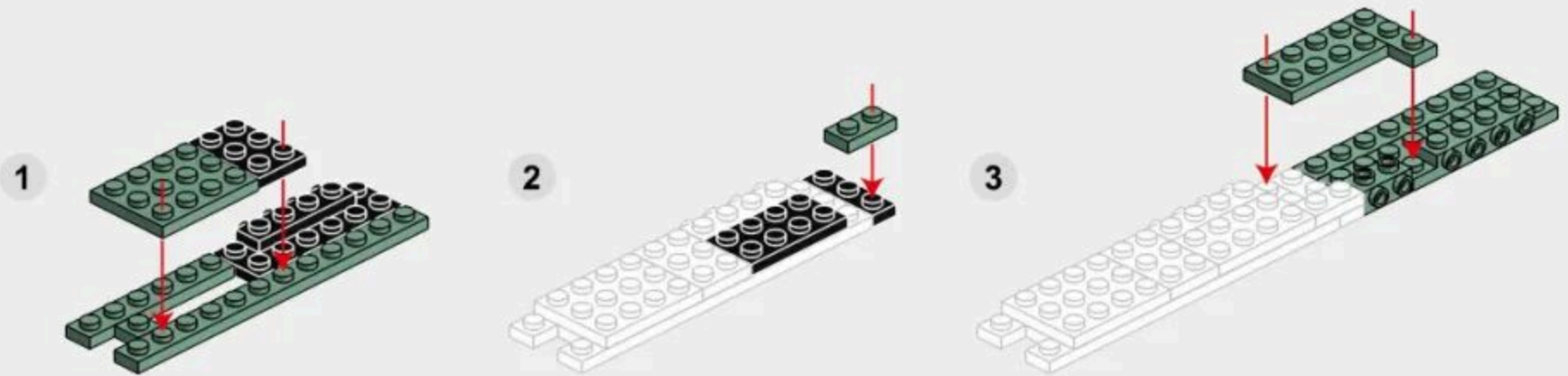
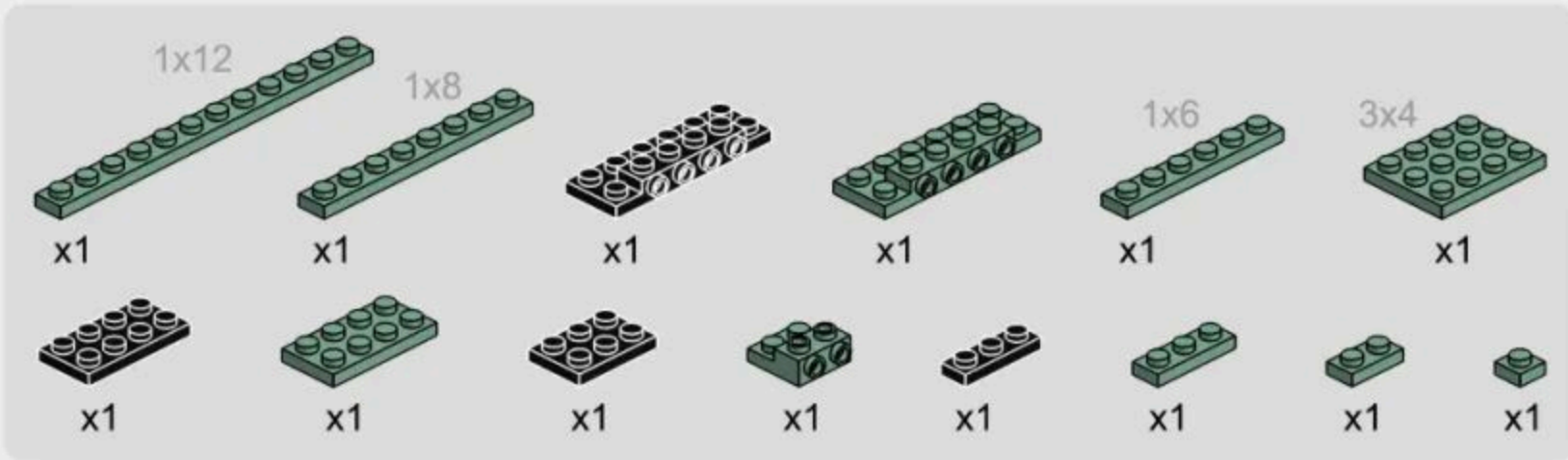







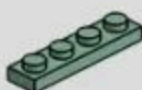





5-1



5-2



5-3

 1x6 x1	 x1	 x1	 x4	 x1	 x4	 x1	 x2	 x1		
 x1	 x4	 x9	 x1	 x3	 x2	 x1	 x1	 x1	 x3	 x3

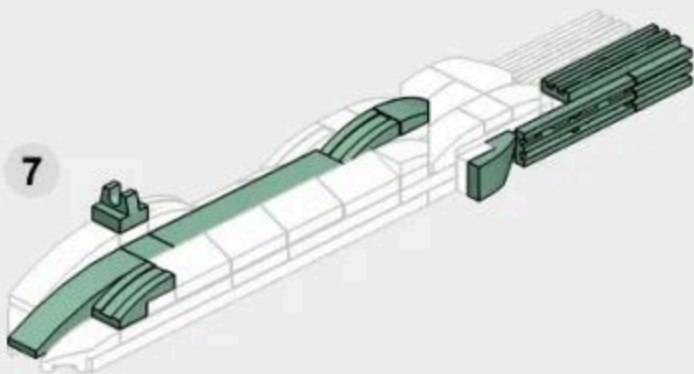
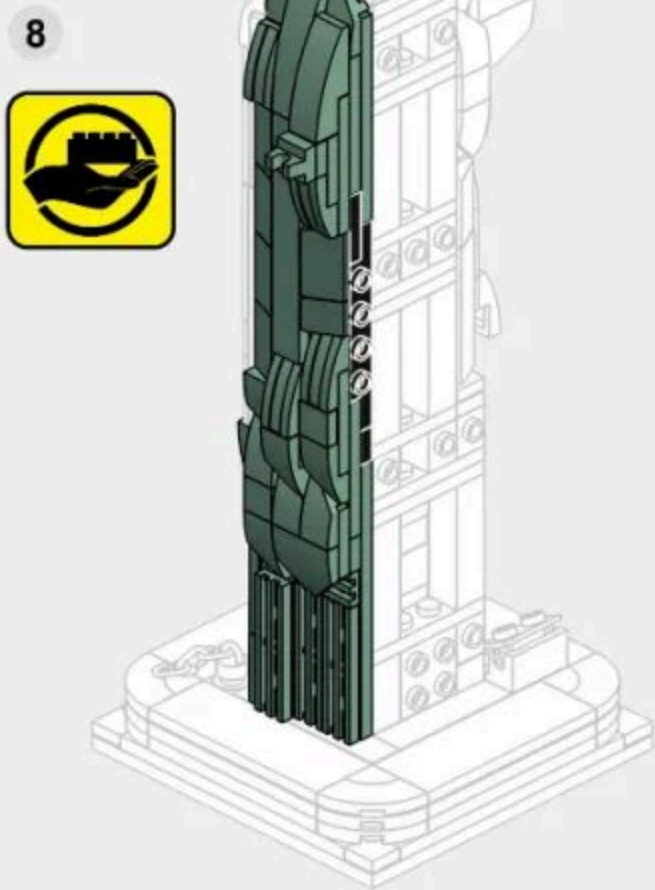
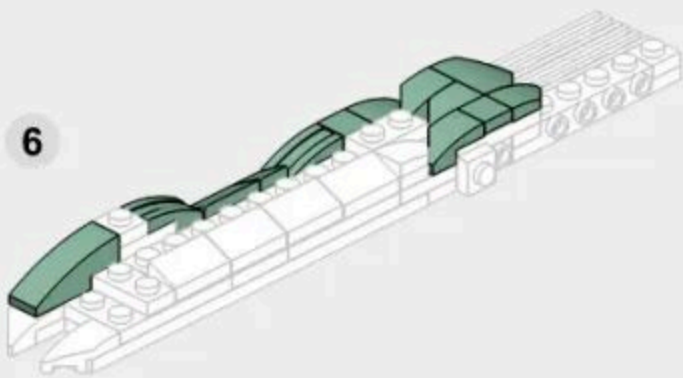
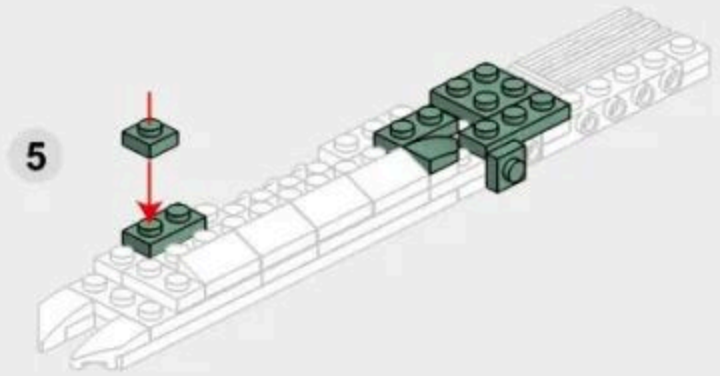
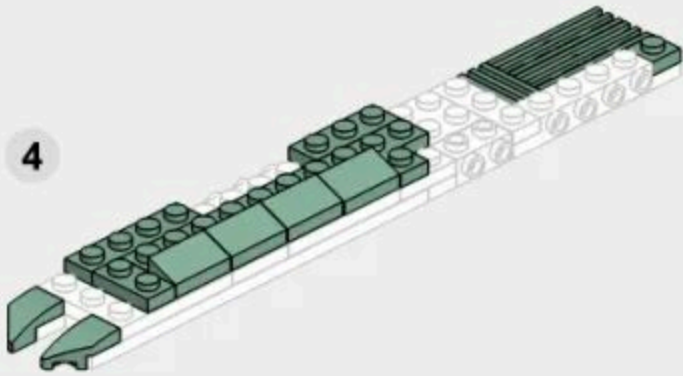

5-4

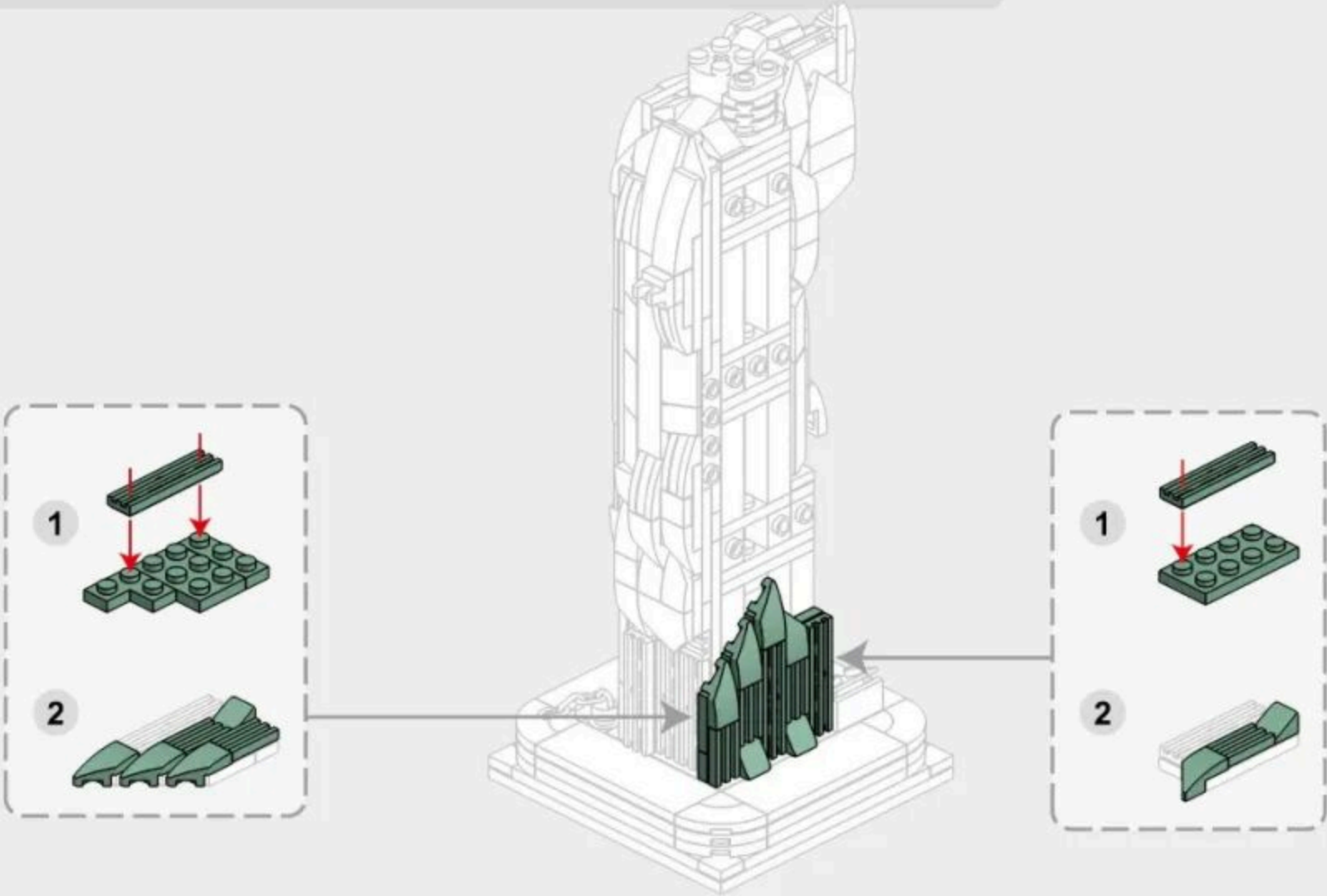
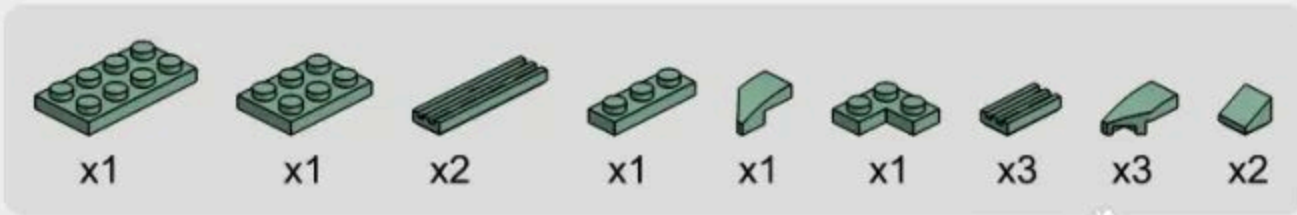

5-5

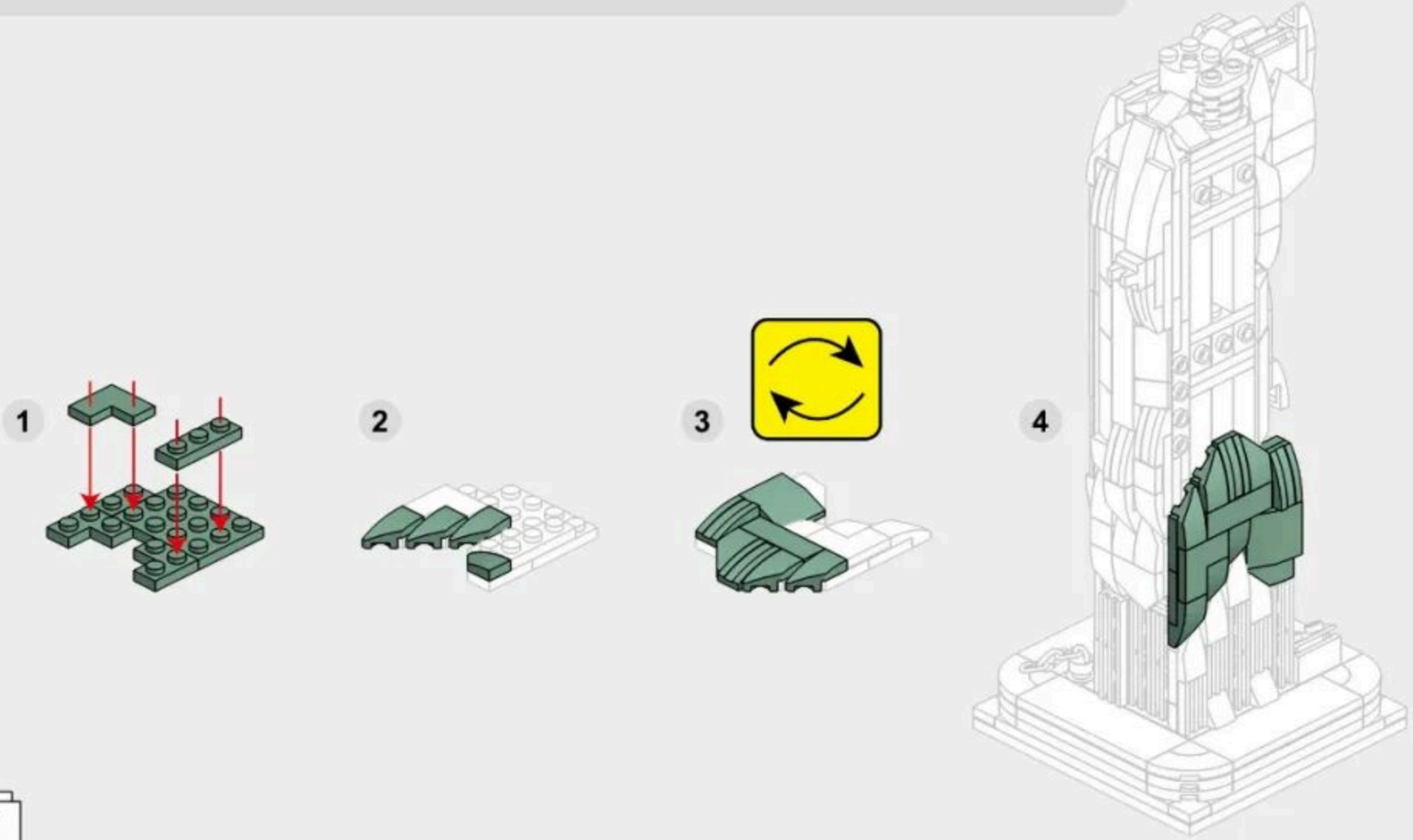
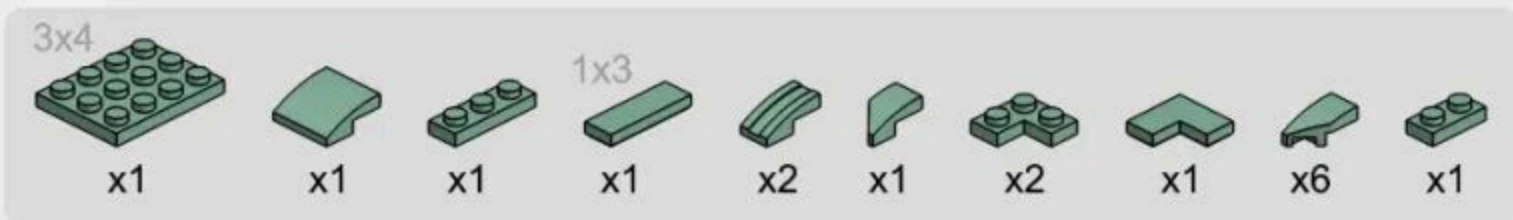

5-6

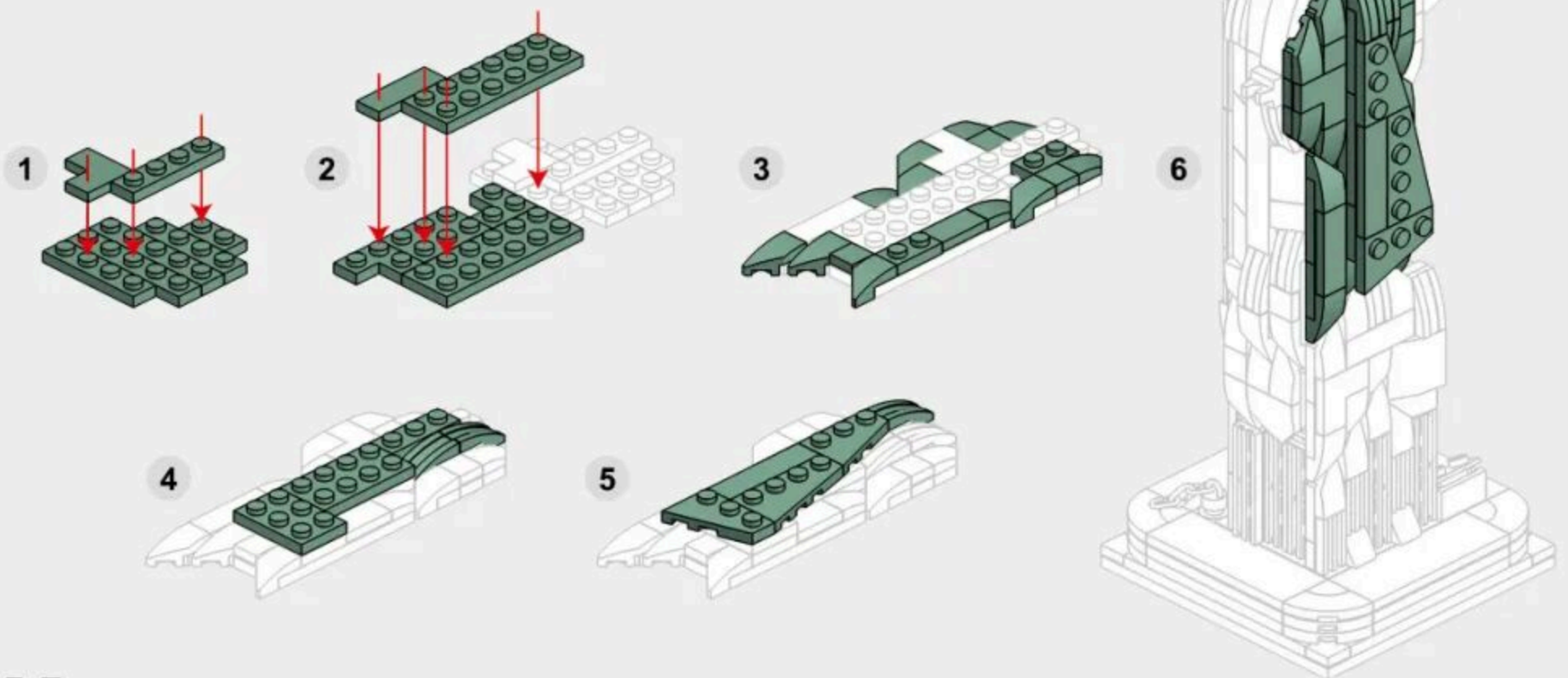
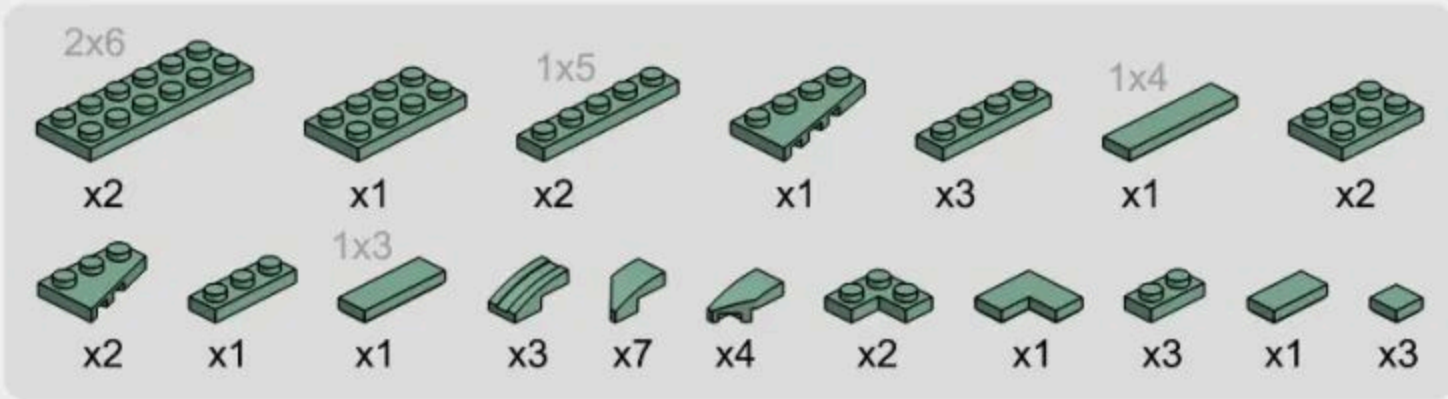

5-7

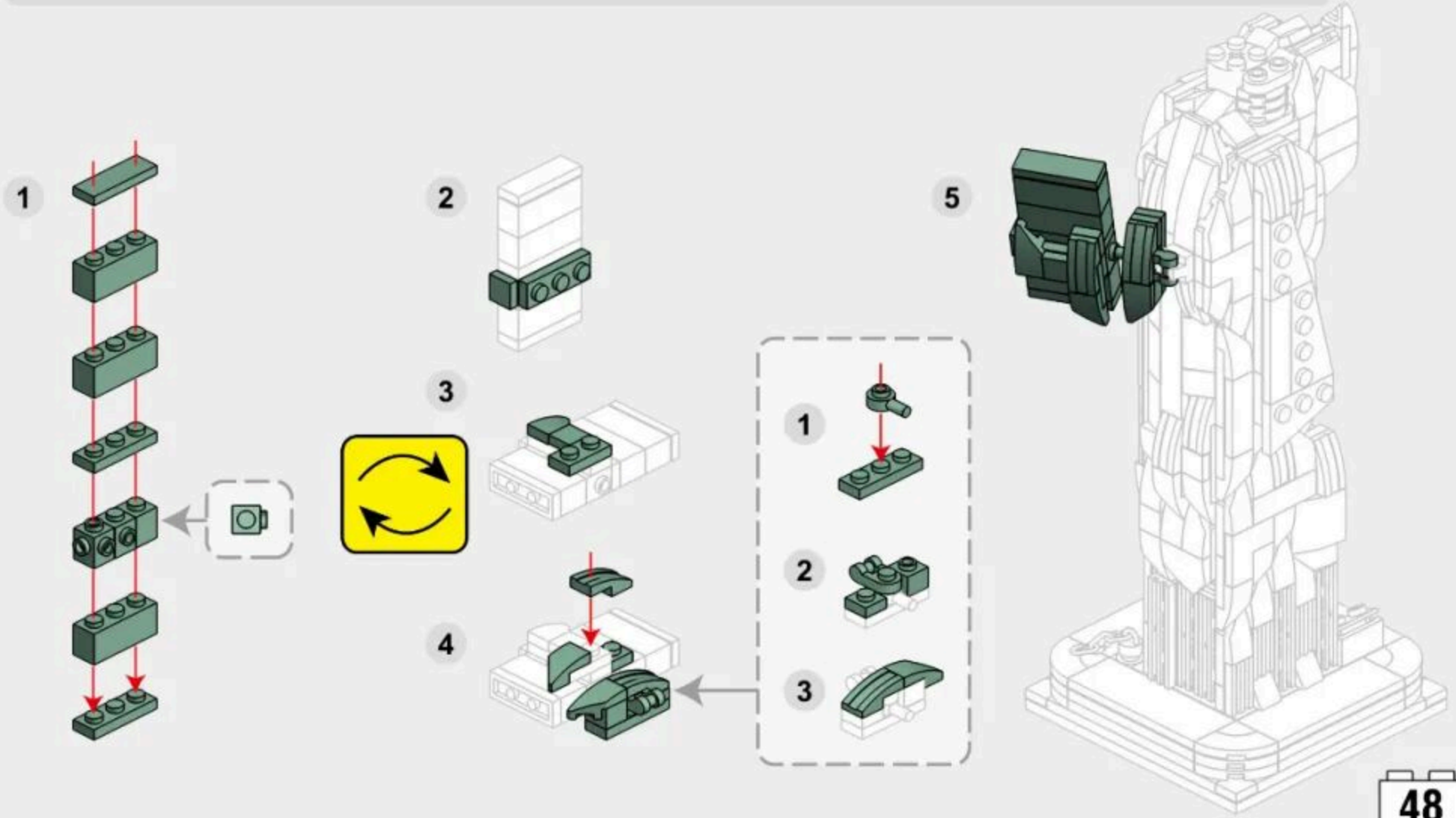

5-8

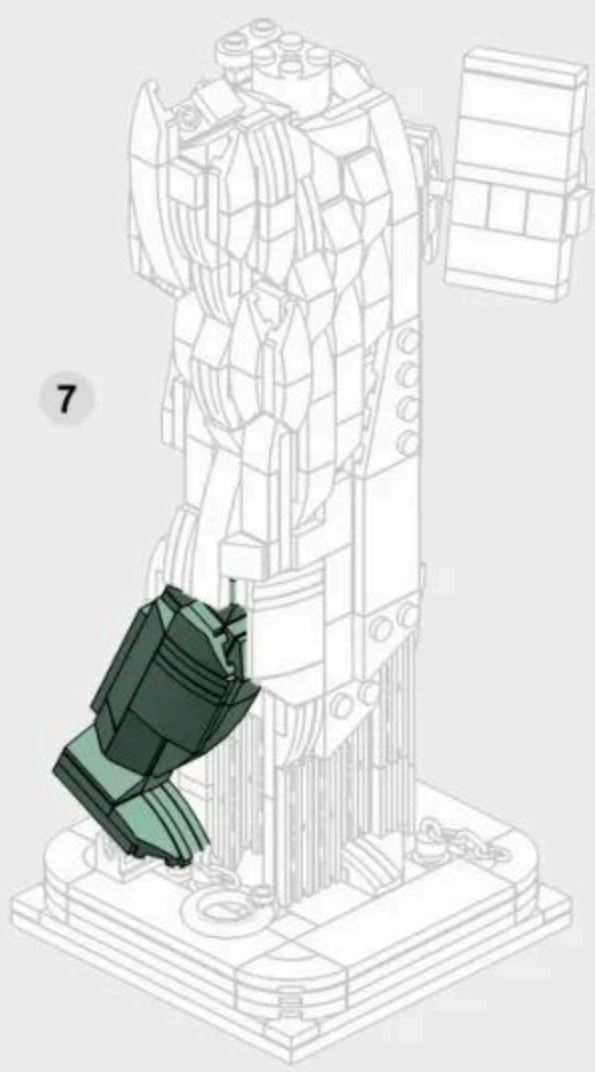
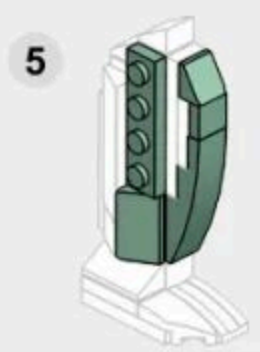
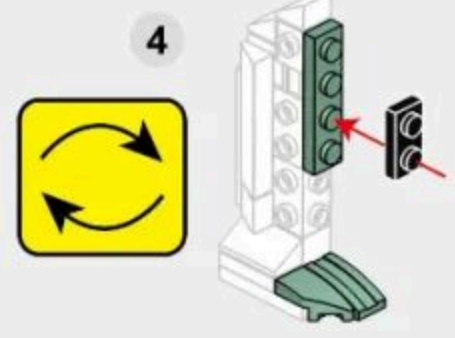
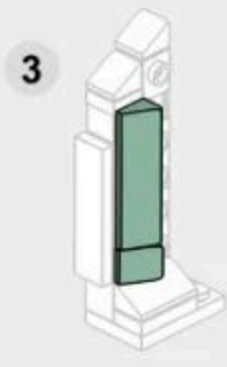
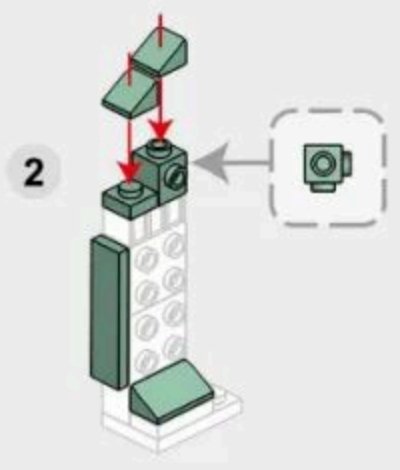
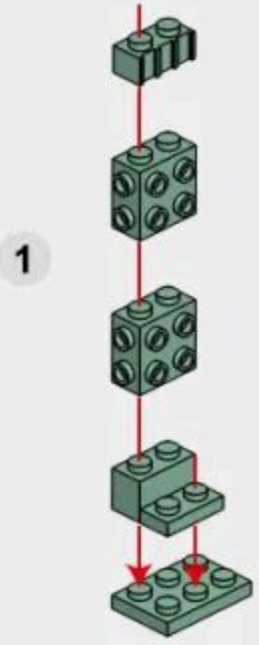
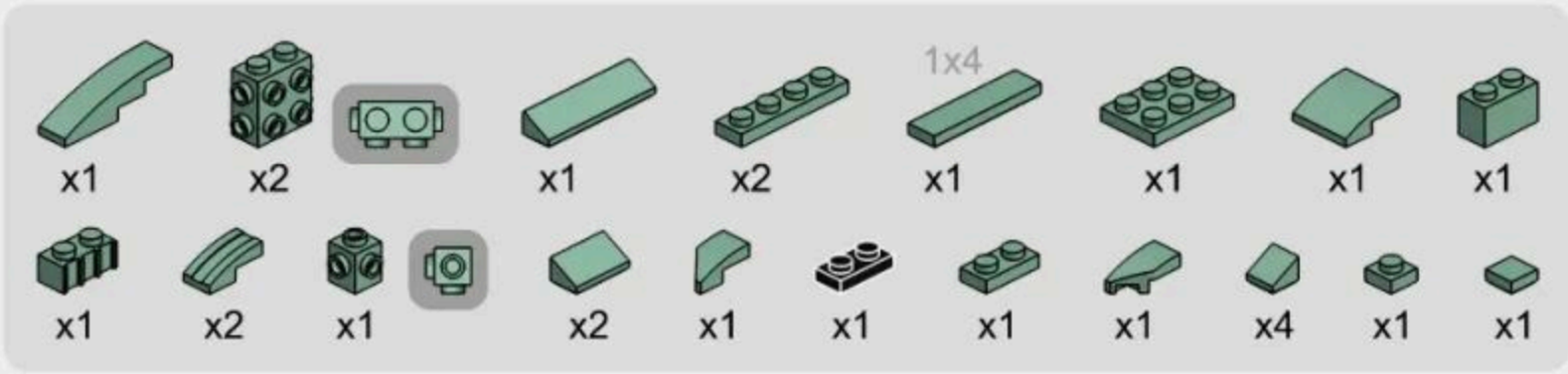

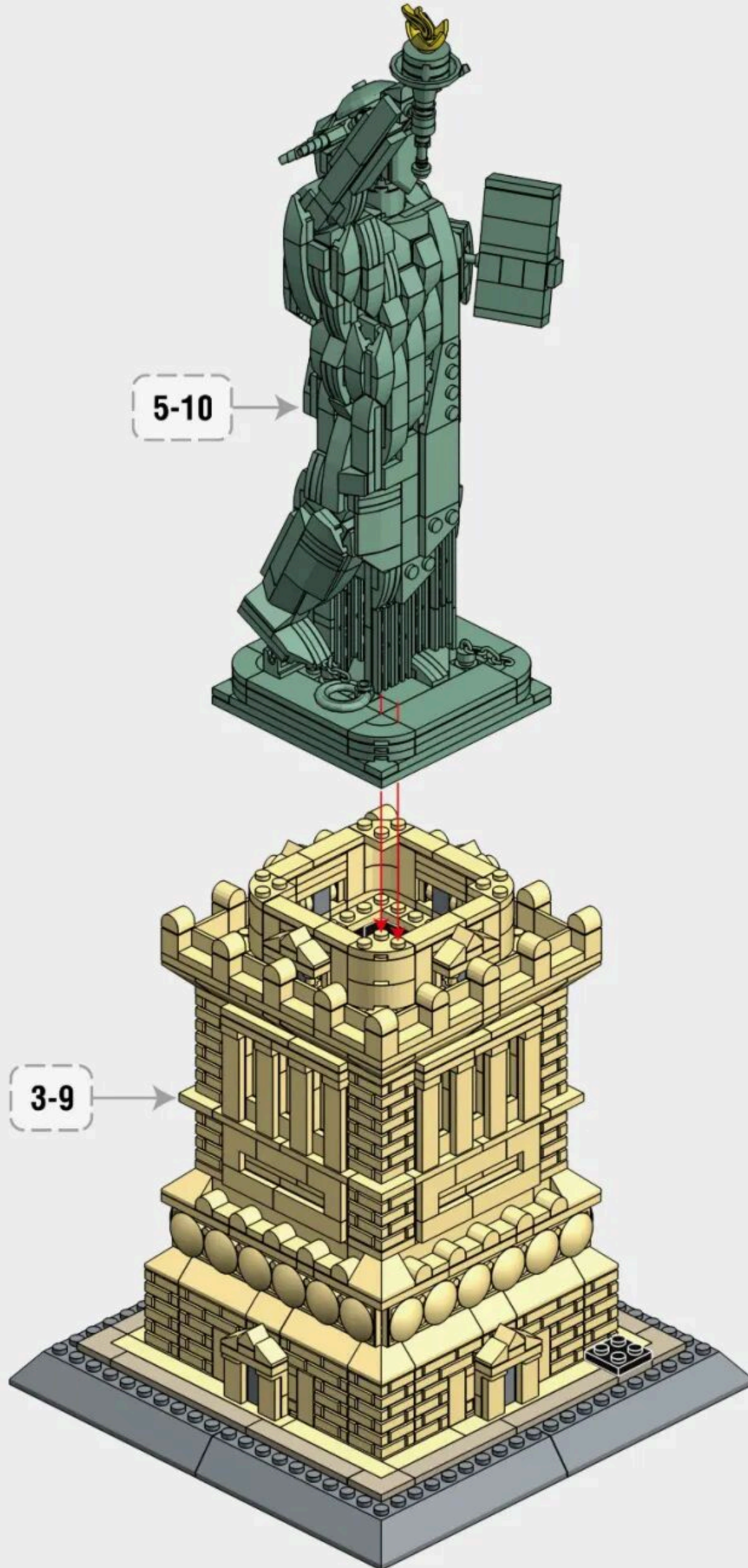

5-12

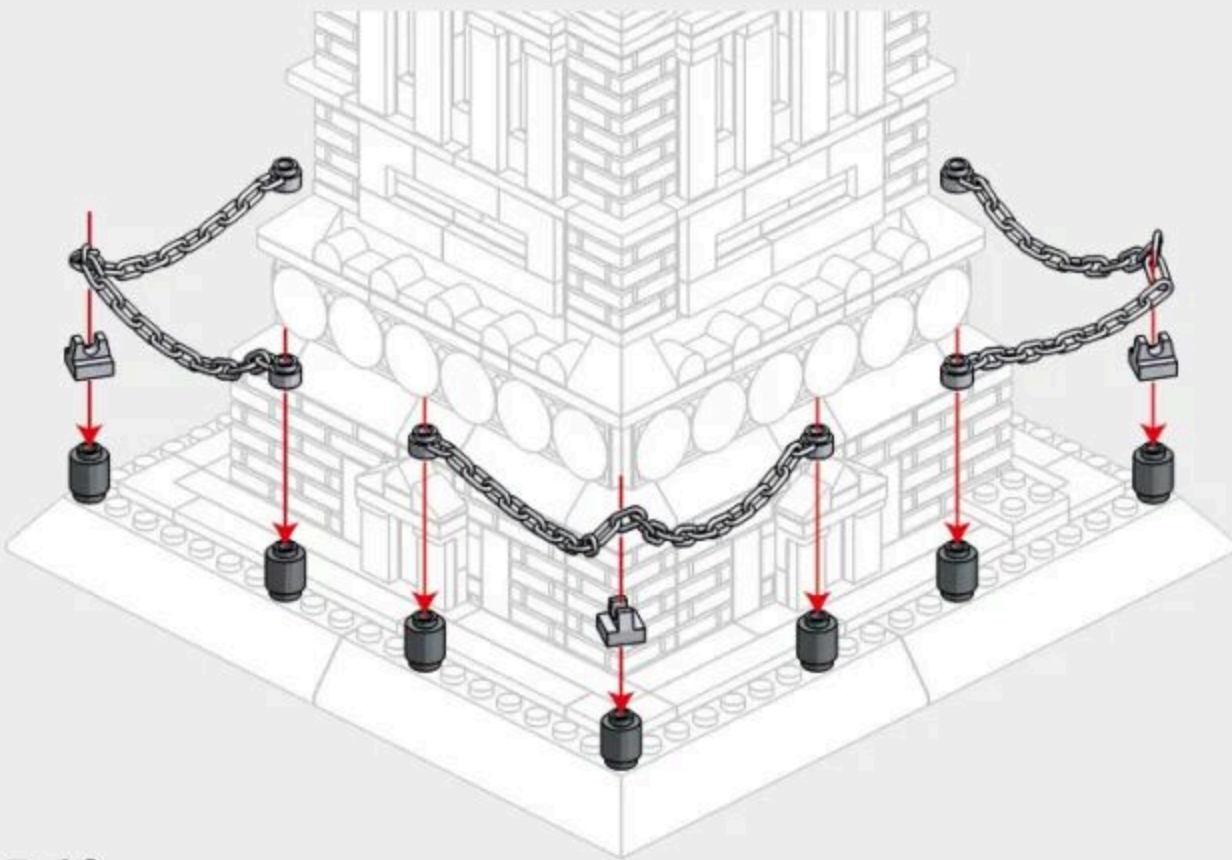

5-13

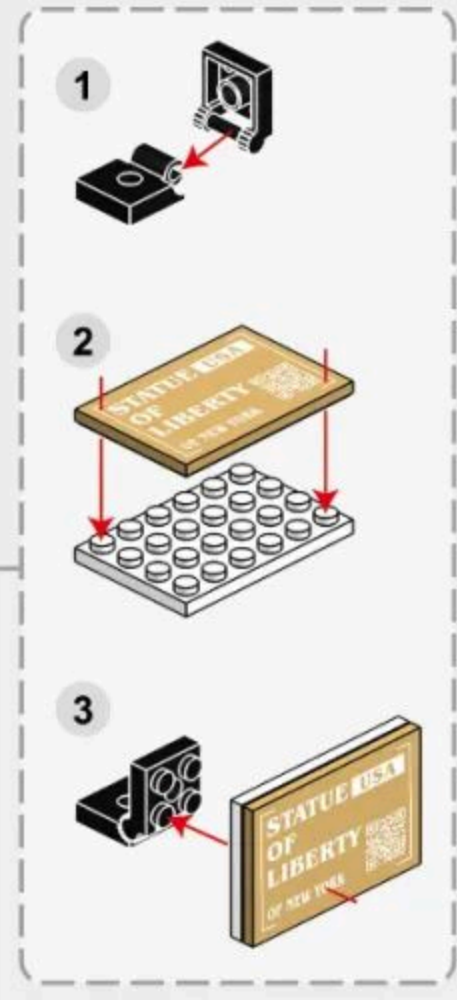
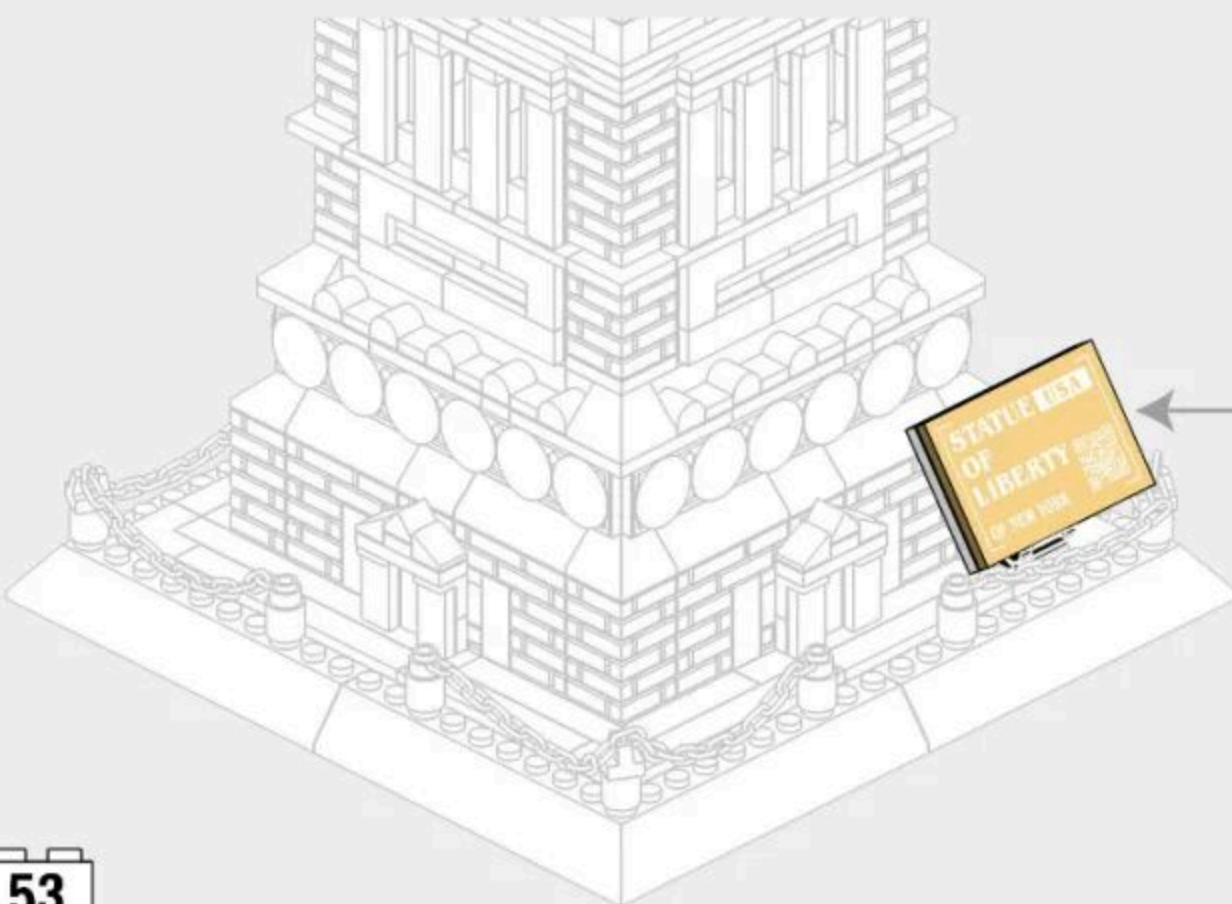
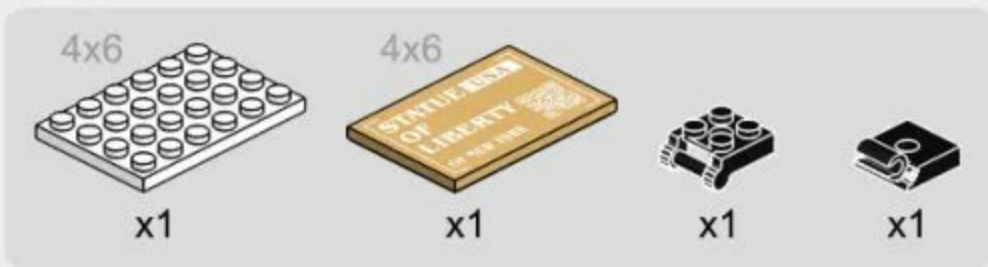



ARCHITECTURE

The World's great architecture

Shaping Skills Imagination & Curiosity Mathematical Self Discovery & Perception Parent-Child Interaction Problem Solving Creativity



6224 英国伦敦白金汉宫
BUCKINGHAM PALACE-LONDON,ENGLAND



5225 意大利罗马斗兽场
COLOSSEUM-ROME,ITALY



5226 日本东京帝国饭店
IMPERIAL HOTEL-TOKYO,JAPAN



5227 美国纽约自由女神像
STATUE OF LIBERTY-NEW YORK,AMERICA



6211 德国柏林勃兰登堡门
BRANDENBURG GATE-BERLIN, GERMANY



6222 中国甘肃长城-嘉峪关
JIAYU PASS-GANSU,CHINA



6212 日本京都清水寺仁王门
NIMON GATE OF KIYOMIZU-DERA-KYOTO,JAPAN



6213 俄罗斯莫斯科瓦西里大教堂
SAINT BASIL'S CATHEDRAL-MOSCOW,RUSSIA



6214 中国武汉黄鹤楼
YELLOW CRANE TOWER-WUHAN,CHINA



6215 英国伦敦眼
LONDON EYE-LONDON,ENGLAND



6221 中国北京故宫-太和殿
HALL OF SUPREME HARMONY-BEIJING,CHINA



6220 沙特阿拉伯麦加大清真寺
GREAT MOSQUE OF MECCA,SAUDI ARABIA



6219 美国纽约联合国大厦
UNITED NATIONS HEADQUARTERS-NEW YORK,AMERICA



4214 美国华盛顿白宫
WHITE HOUSE-WASHINGTON D.C.,AMERICA



4212 意大利罗马许愿池
TREVI FOUNTAIN-ROME,ITALY



4213 法国巴黎卢浮宫
MUSÉE DU LOUVRE-PARIS,FRANCE

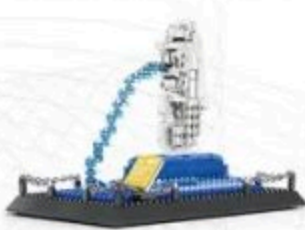

4218 新加坡-鱼尾狮
MERLION,SINGAPORE



4219 英国伦敦双子塔桥
TOWER BRIDGE-LONDON,ENGLAND



4216 美国华盛顿林肯纪念堂
LINCOLN MEMORIAL-WASHINGTON D.C.,AMERICA



4217 新加坡-金沙酒店
MARINA BAY SANDS,SINGAPORE



4210 埃及开罗吉萨金字塔
GREAT PYRAMID OF GIZA-CAIRO,EGYPT



4221 加拿大渥太华国会山庄
PARLIAMENT BUILDINGS-OTTAWA,CANADA



4211 英国伦敦伊丽莎白塔
ELIZABETH TOWER-ENGLAND



4215 加拿大多伦多电视塔
THE CN TOWER-CANADA



4220 美国纽约熨斗大厦
FLATIRON BUILDING-NEW YORK,AMERICA



4222 阿联酋迪拜哈利法塔
THE BURJ KHALIFA TOWER-DUBAI, UAE



5224 中国上海东方明珠广播电视塔
ORIENTAL PEARL TOWER-SHANGHAI, CHINA



5212 美国纽约帝国大厦
EMPIRE STATE BUILDING-NEW YORK, AMERICA



5213 马来西亚吉隆坡石油双塔
PETRONAS TWIN TOWERS-KUALA LUMPUR, MALAYSIA



5214 意大利托斯卡纳比萨斜塔
LEANING TOWER OF PISA-TUSCANY, ITALY



5216 英国伦敦伊丽莎白塔
ELIZABETH TOWER-LONDON, ENGLAND



5219 俄罗斯莫斯科克里姆林宫钟楼
SPASSKAYA TOWER-MOSCOW, RUSSIA



5220 阿联酋迪拜卓美亚帆船酒店
BURJ AL ARAB HOTEL-DUBAI, UAE



5217 法国巴黎埃菲尔铁塔
EIFFEL TOWER-PARIS, FRANCE



5221 中国台北101大楼
TAIPEI 101-TAIPEI, CHINA



5228 美国芝加哥威利斯大厦
WILLIS TOWER-CHICAGO, AMERICA



5231 巴西里约热内卢救世基督像
CRISTO REDENTOR-RIO DE JANEIRO, BRASIL



6223 中国武汉长江大桥
WUHAN YANGTZE RIVER BRIDGE



5210 法国巴黎圣母院大教堂
CATHÉDRALE NOTRE DAME DE PARIS-PARIS, FRANCE



5211 印度阿格拉泰姬陵
TAJ MAHAL-AGRA, INDIA



5223 法国巴黎凯旋门
ARC DE TRIOMPHE-PARIS, FRANCE



5215 英国伦敦双子塔桥
TOWER BRIDGE-LONDON, ENGLAND



5222 中国北京天坛祈年殿
HALL OF PRAYER FOR GOOD HARVESTS-BEIJING, CHINA



6210 美国旧金山金门大桥
GOLDEN GATE BRIDGE-SAN FRANCISCO, AMERICA



6216 中国北京万里长城(八达岭)
THE GREAT WALL-BEIJING, CHINA



5218 中国北京天安门
TIANANMEN TOWER-BEIJING, CHINA



6217 中国西藏布达拉宫
POTALA PALACE-TIBET, CHINA



6218 芬兰罗瓦涅米圣诞老人办公室
SANTA CLAUS OFFICE-ROVANIEMI, FINLAND



6225 墨西哥库库尔坎玛雅金字塔
EL CASTILLO-KUKULKAN, MEXICO



6226 德国巴伐利亚新天鹅堡
SCHLOSS NEUSCHWANSTEIN-BAYERN, DEUTSCHLAND



5229 土耳其伊斯坦布尔少女塔
MAIDEN TOWER-ISTANBUL, TURKEY



5230 中国湖南长沙爱晚亭
AIWANTING PAVILION-HUNAN, CHINA



7210 中国上海世博会中国馆
CHINA PAVILION AT EXPO-SHANGHAI, CHINA



5232 美国宾夕法尼亚州流水别墅
FALLING WATER-PENNSYLVANIA, AMERICA



5233 美国芝加哥范斯沃斯住宅
FARNSWORTH HOUSE-CHICAGO, AMERICA



5234 美国华盛顿唐人街
CHINA TOWN-WASHINGTON, D.C., AMERICA



3210 美国纽约自由女神像
STATUE OF LIBERTY-NEW YORK, AMERICA



4223 中国北京清华园
TSINGHUA CAMPUS-BEIJING, CHINA



7211 中国湖南岳阳楼
YUEYANG TOWER-HUNAN, CHINA



8210 澳大利亚悉尼歌剧院
SYDNEY OPERA HOUSE-BENNELONG POINT, AUSTRALIA



7212 中国江西南昌滕王阁
PAVILION OF PRINCE TENG-JIANGXI, CHINA



6227 中国河南郑州嵩山少林寺
SHAOLIN TEMPLE-HENAN, CHINA



7213 中国重庆洪崖洞
HONGYADONG-CHONGQING, CHINA



5235 美国华盛顿国会大厦
UNITED STATES CAPITOL-WASHINGTON D.C., AMERICA



5236 中国安徽滁州醉翁亭
ZUIWENG PAVILION-ANHUI, CHINA



6228 中国陕西西安钟楼
XI'AN BELL TOWER-SHAANXI, CHINA



5238 美国西雅图太空针塔
SPACE NEEDLE-SEATTLE, AMERICA



5237 法国巴黎萨伏伊别墅
VILLA SAVOYE-PARIS, FRANCE



6229 中国山西运城鹳雀楼
STORK TOWER-SHANXI, CHINA



6230 希腊爱情海圣托里尼岛
SANTORINI-FIRA, GREECE



6231 中国上海海关大楼
SHANGHAI CUSTOMS HOUSE-SHANGHAI, CHINA



5239 中国北京紫禁城角楼
TURRET OF PALACE MUSEUM-BEIJING, CHINA



5240 韩国首尔崇礼门
NAMDAEMUN-SEOUL, KOREA



5241 中国江苏南京夫子庙
CONFUCIUS TEMPLE-JIANGSU, CHINA



5242 美国纽约古根海姆博物馆
GUGGENHEIM MUSEUM-NEW YORK, AMERICA



6232 中国江苏南京秦淮河画舫
QINHUI RIVER PAINTED BOAT-JIANGSU, CHINA



6233 法国诺曼底圣米歇尔山
SAINT MICHAEL'S MOUNT-NORMANDY, FRANCE



6234 中国河南洛阳栾川老君山
THE LAOJUN MOUNTAIN-HENAN, CHINA



5243 耶路撒冷岩石圆顶
DOME OF THE ROCK-JERUSALEM



6235 中国江苏苏州寒山寺 (普明宝塔)
HANSHAN TEMPLE-JIANGSU, CHINA



4224 英国威尔特郡巨石阵
STONEHENGE-WILTSHIRE, ENGLAND



4225 中国内蒙古自治区蒙古包
MONGOLIAN YURT-INNER MONGOLIA, CHINA



8211 中国福建土楼(承启楼)
CHENGQI EARTH BUILDING-FUJIAN, CHINA



4226 沙特阿拉伯麦加大清真寺(克尔白)
KERBAL, GREAT MOSQUE OF MECCA, SAUDI ARABIA



5244 俄罗斯圣彼得堡冬宫
WINTER PALACE-ST.PETERSBURG, RUSSIA



7214 中国陕西西安鼓楼
XI'AN DRUM TOWER-SHAANXI, CHINA



5245 中国重庆李子坝站
LIZIBA STATION-CHONGQING, CHINA



4227 俄罗斯莫斯科国立大学
MOSCOW STATE UNIVERSITY-MOSCOW, RUSSIA



4228 沙特阿拉伯麦地那先知清真寺
PROPHET'S MOSQUE-MEDINA, SAUDI ARABIA



6236 中国浙江杭州雷峰塔
LEIFENG PAGODA-HANGZHOU, ZHEJIANG, CHINA



5246 美国芝加哥罗宾别墅
ROBIE HOUSE-CHICAGO, AMERICA



5247 中国陕西西安大雁塔
GIANT WILD GOOSE PAGODA-SHAANXI, CHINA



5249 英国伦敦特拉法加广场
TRAFALGAR SQUARE-LONDON, ENGLAND



5248 美国纽约洛克菲勒中心
ROCKEFELLER CENTER-NEW YORK, AMERICA





STATUE OF LIBERTY

COUNTRY: America
CITY: New York

