



# WILLIS TOWER

## TORRE WILLIS

Chicago, Illinois, America

The world's great architecture



Creative Ability



Family Interaction



Observation Ability



Thinking Ability



Practical Ability



6+  
Suitable Age

5228  
Product Number

1241 PCS  
Parts Total



# Architecture

It will be a city...

这将构成一座城市...

# ABOUT THE PRODUCT

关于产品

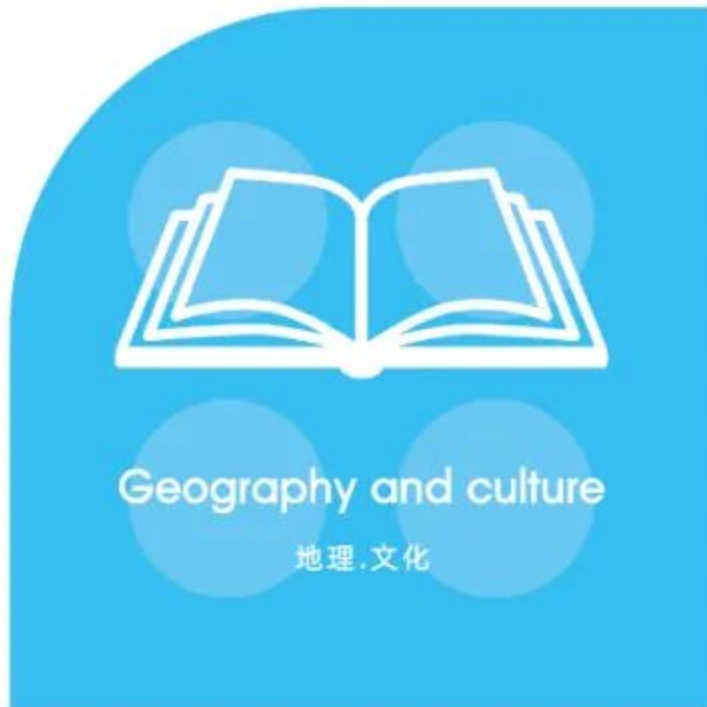

## ARCHITECTURE

WANGE The world's great architect since 1991

# Willis Tower

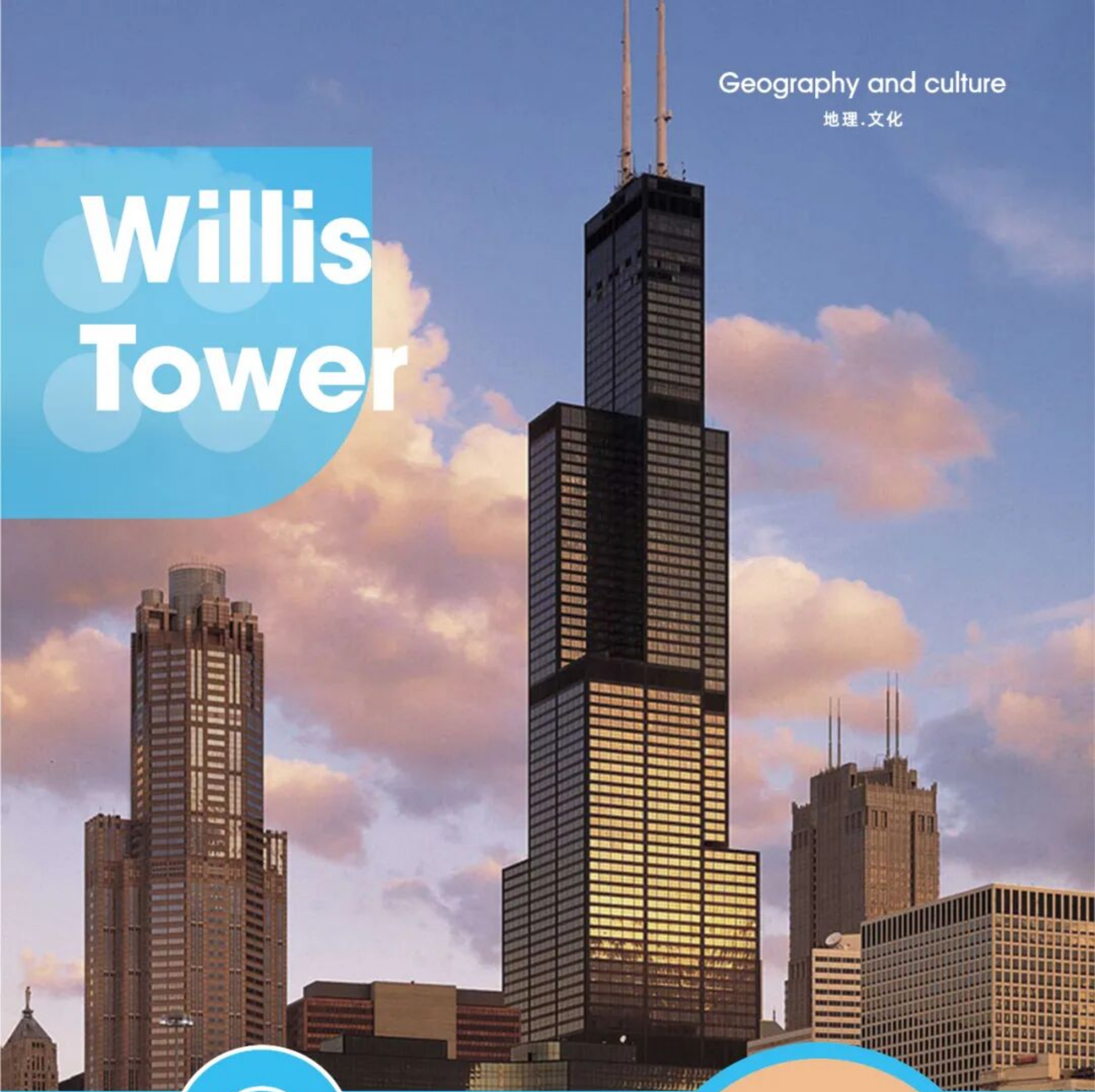

The Willis Tower (formerly and informally: Sears Tower, its name until 2009) is a 108-story, 1,450-foot (442.1 m) skyscraper in Chicago.

# Willis Tower



## Geography and culture

地理·文化



The tower has 108 stories as counted by standard methods, though the building's owners count the main roof as 109 and the mechanical penthouse roof as 110.

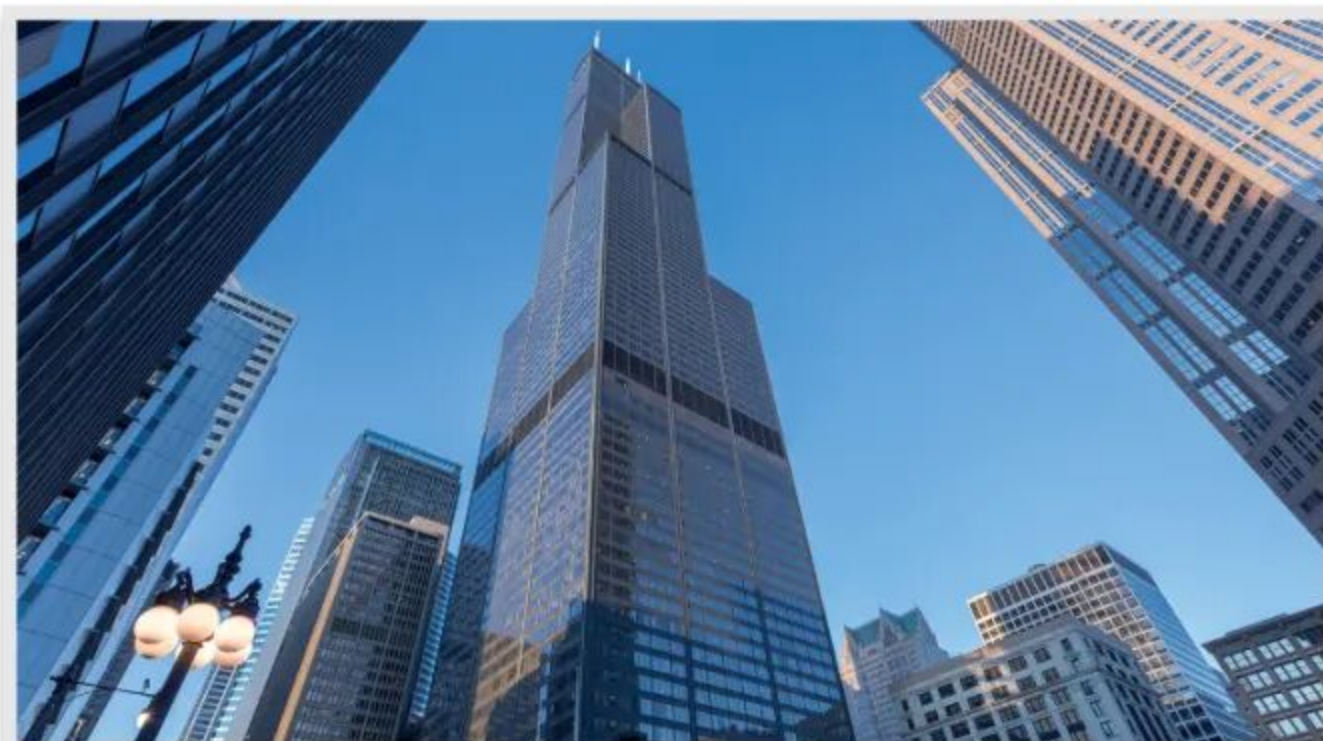



Torre Willis

# Willis Tower ■

America

The contents of this chapter refer to the Wikipedia website.

本章内容参考维基百科网站，  
更多资讯可自行查阅。

The world's great architecture

# Buildings and layout

■ 建筑物和布局



**The Willis Tower** is a 108-story, 1,450-foot (442.1 m) skyscraper in Chicago. The tower has 108 stories as counted by standard methods, though the building's owners count the main roof as 109 and the mechanical penthouse roof as 110. At completion in 1974, it surpassed the World Trade Center in New York City to become the tallest building in the world, a title that it held for nearly 25 years

La Torre Willis o Willis Tower (nombrada antiguamente como Sears Tower) es un rascacielos de 442 metros en Chicago, Illinois. En el momento de su inauguración, fue el edificio más alto del mundo durante veinte años. Con 442 metros de altura arquitectónica y 527 metros de altura máxima, la Torre Willis es la tercera torre más alta de América, después de la Torre CN y el One World Trade Center de Nueva York, y la segunda más alta de Estados Unidos, después del One World Trade Center en Nueva York, superando por 27 metros al Trump International Hotel and Tower, también en Chicago.



## Structure

Willis Tower is considered a seminal achievement for engineer Fazlur Rahman Khan. It is currently the third-tallest building in the United States and the Western hemisphere – and the 23rd-tallest in the world. Each year, more than one million people visit its observation deck, the highest in the United States, making it one of Chicago's most popular tourist destinations. The structure was renamed in 2009 by the Willis Group as a term of its lease.

Como Sears continuaba teniendo planes optimistas de crecimiento, la altura propuesta para la torre avanzó hasta más de 100 pisos y sobrepasó la altura del incompleto World Trade Center en Nueva York que se convertiría en el edificio más alto del mundo. 2009, Willis Group Holdings, acordó un contrato de arrendamiento de una parte del edificio y obtuvo los derechos del nombre de la torre.



## Design and construction

Willis Tower which needed 3 million square feet (280,000 m<sup>2</sup>) of office space for its planned consolidation and predicted growth, commissioned architects Skidmore, Owings & Merrill (SOM). Their team of Colombian-Peruvian architect Bruce Graham and Bangladeshi-Pakistani structural engineer Fazlur Rahman Khan designed the building as nine square "tubes" (each essentially a separate building), clustered in a 3×3 matrix forming a square base with 225-foot (69 m) sides. All nine tubes would rise up to the 50th floor of the building, where the northwest and southeast tubes terminate.

Con demandas de espacio de 3 millones de pies cuadrados (280 000 de metros cuadrados), y con predicciones de una futura expansión necesitando espacio, Sears contrató a Skidmore, Owings and Merrill (SOM) para construir una estructura que se convertiría en uno de los edificios de oficinas más altos del mundo. El equipo del arquitecto Bruce Graham y el ingeniero Fazlur Rahman Khan diseñaron el edificio como 9 "tubos" cuadrados, cada uno, esencialmente un edificio separado cada uno. Los 9 tubos se alzarían hasta el piso número 50 del edificio. En ese piso, los tubos noroeste y sudeste terminan, y los otros 7 continúan subiendo.

# Drawing Design

手绘设计



# Special parts

特殊零件的开发利用

$$S=4\pi \cdot r^2$$



**WG015**

直角6孔

$$a^2+b^2=c^2$$



**WG530**

1孔5高



**WG1149**

圆凸孔



**WG1257**

5倍柱珠高1孔



$$\sin^2 a + \cos^2 a = 1$$

**WG1345**

竖纹2倍2孔



features and functions

特点.功能

# Design Points

结构难点

Angle calculation  
角度的计算

$$S=4\pi\cdot r^2$$

$$a^2+b^2=c^2$$

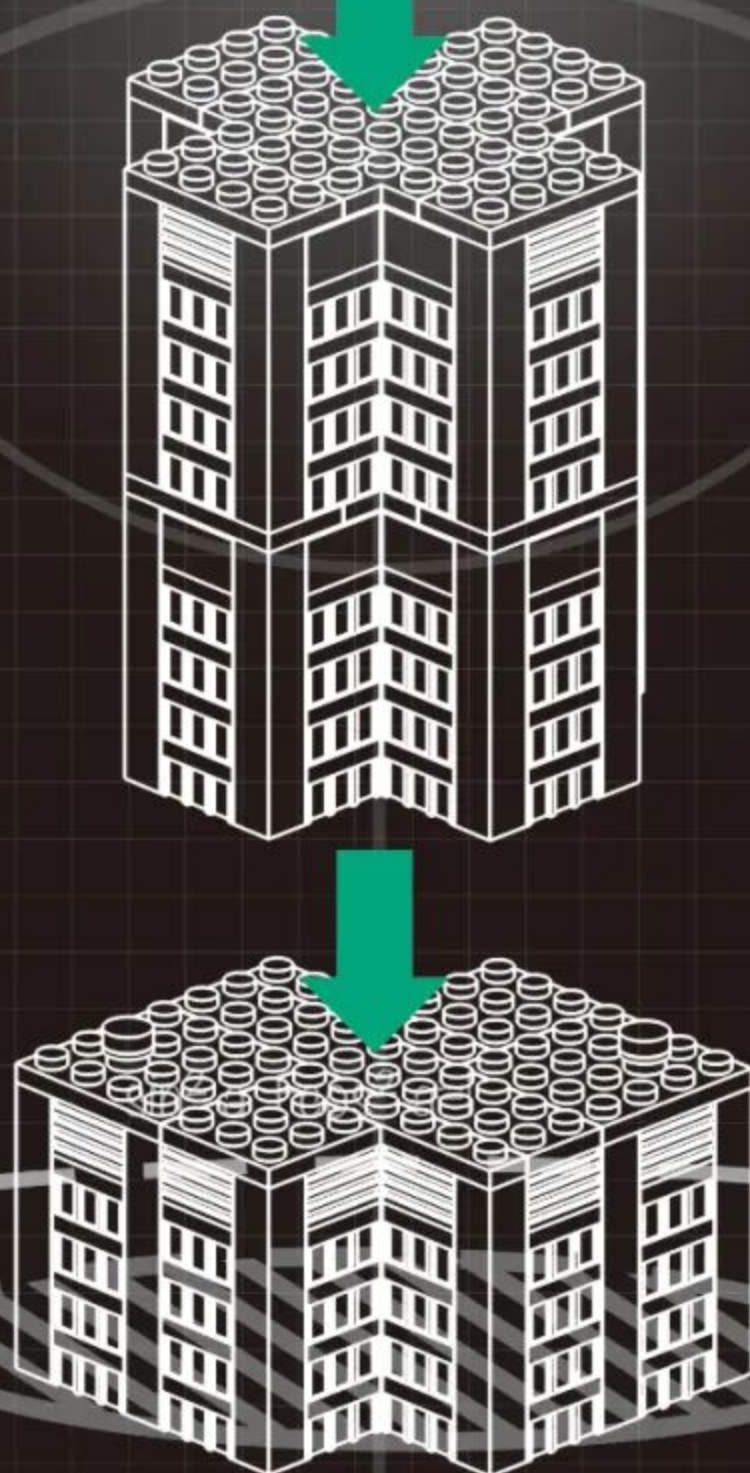

Creation and thinking

创作·思考

10

# Force Balance

受力平衡

Physical operations

物理运算

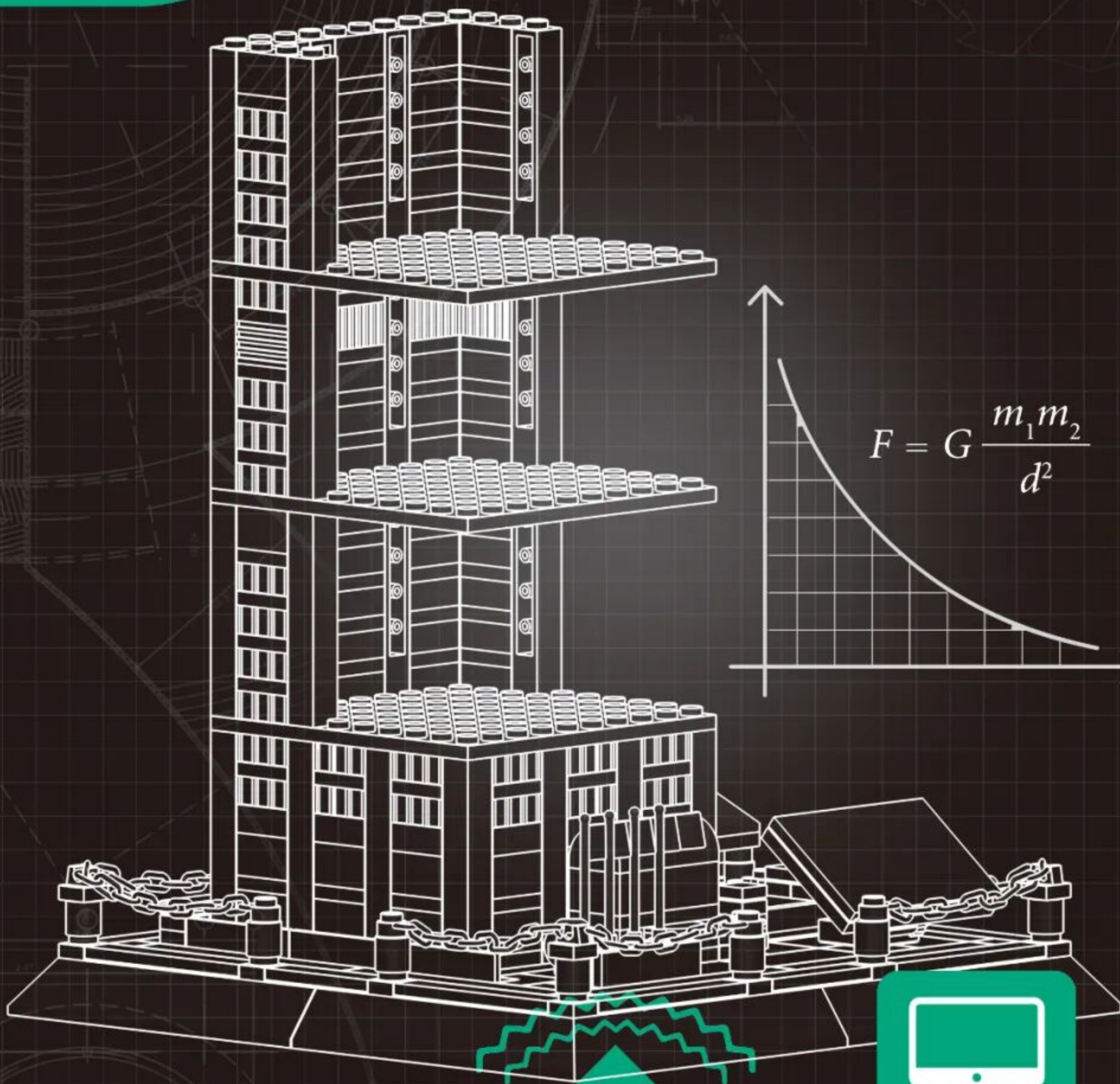

Creation and thinking

创作·思考

# Main Color Matching

配色方案



Pantone 2333C

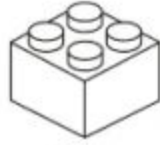

White



Pantone 7509C



Pantone black6C



Pantone 477C



Pantone 431C



Pantone 472C



## Color matching

Adopting 7 main colors, gray, dark gray, soil yellow, Dark flesh, Brown, Transparent white, black and white as the main color, the more reasonable and bold color matching on the original building, making the product more atmospheric and the whole design is more reasonable.

# The Willis Tower

威利斯大厦

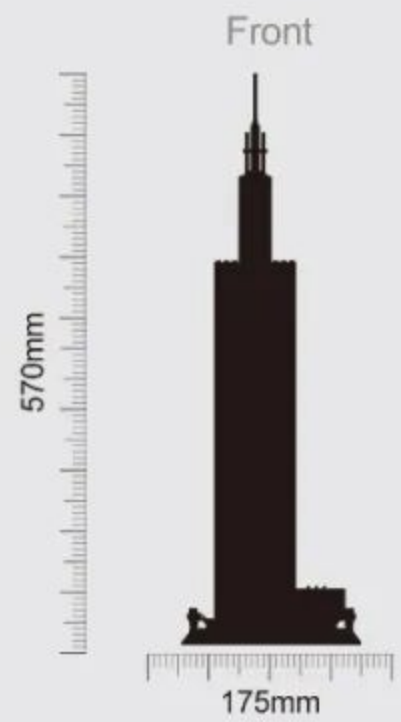
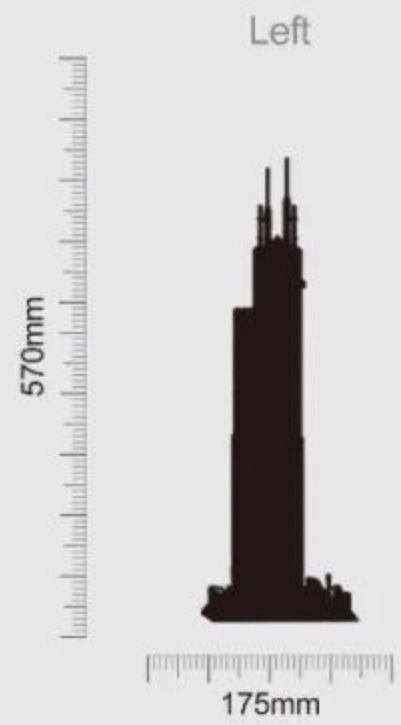
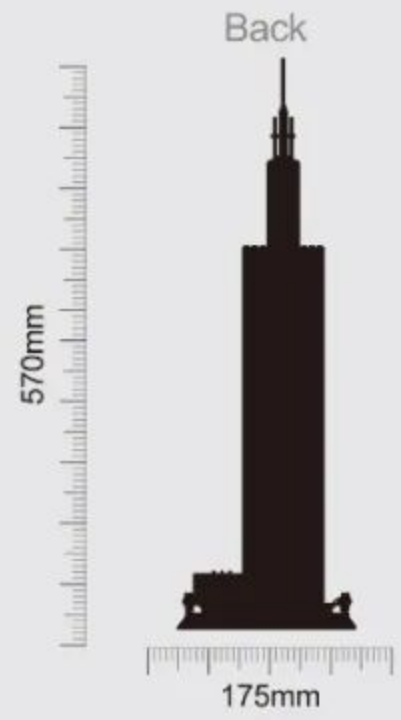

Product Size: 175X175x570mm

- Creative Ability
- Family Interaction
- Observation Ability
- Thinking Ability
- Practical Ability

# Instructions For Use

积木起件器使用说明  
Brickseparator

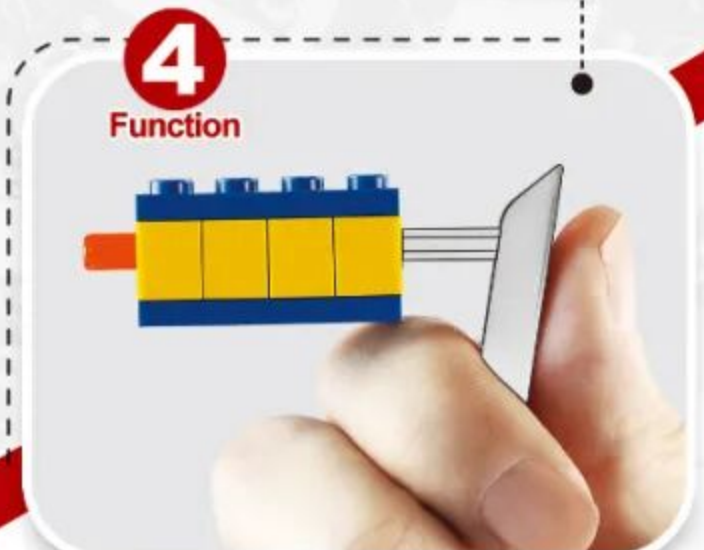
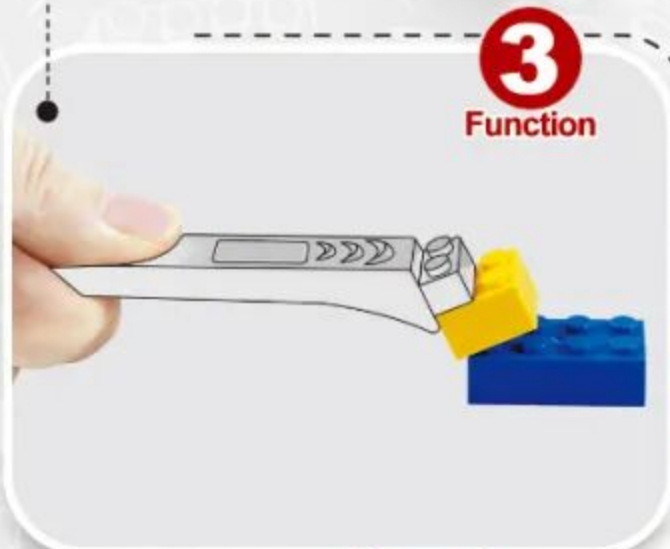
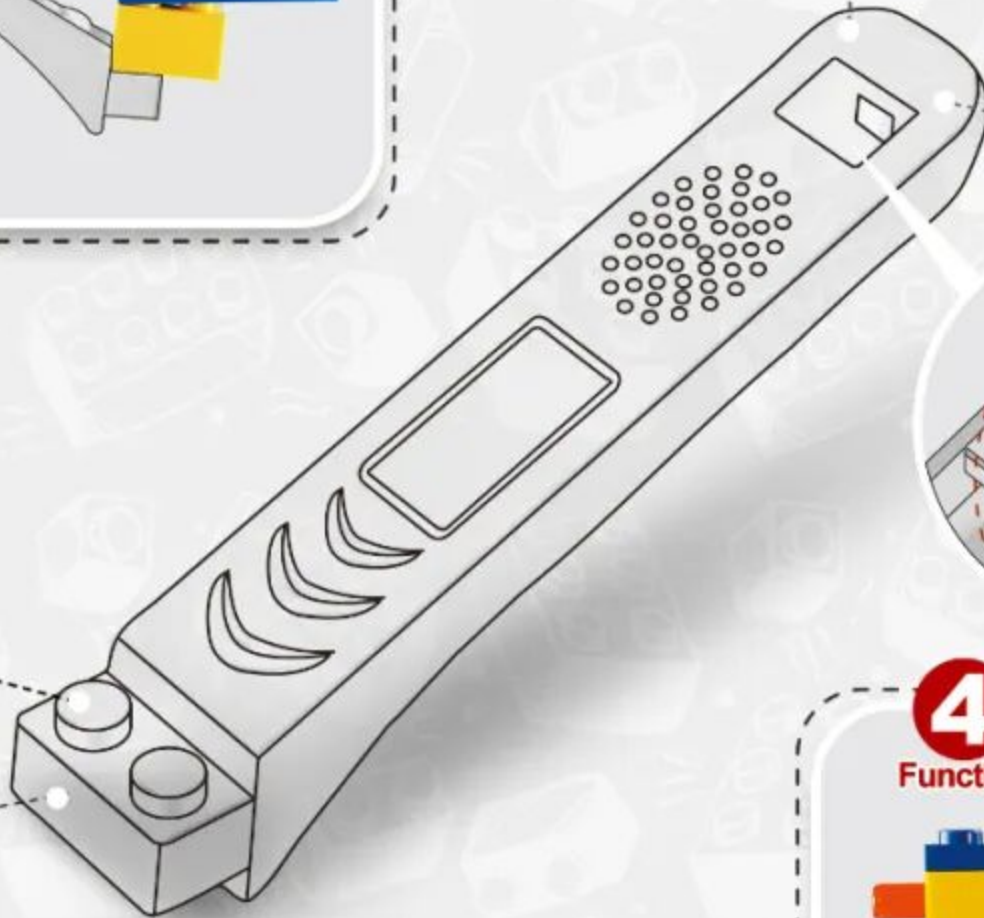
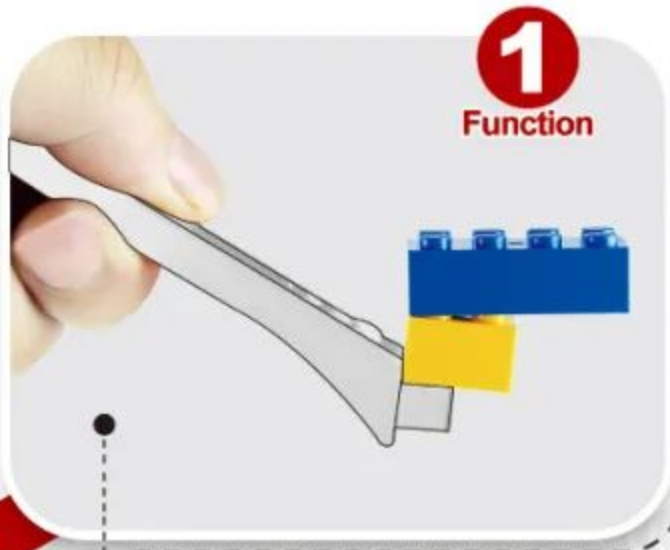

4 ways to make installation easier  
让安装更简单



■ First open the product packaging according to the instructions.

按指导用正确方式拆解产品外包装。



■ Summarize all parts to count the number of familiar accessories.

对照说明书清单确认积木包数量与积木数量。



■ Arranging all accessories by color helps to quickly install the product.

把确认好的积木以类型、颜色进行分类排好以便安装。



■ Carefully install the product and learn about building.

按说明书步骤拼装并完成你的积木模型。



# 1:1 Physical Reference Table

十字棒配件1:1尺寸参照表



Instructions For Use

让安装更简单



**2**  $(1 \times 2) = 2$

**3**  $(1 \times 3) = 3$

**4**  $(1 \times 4) = 4$

**5**  $(1 \times 5) = 5$

**6**  $(1 \times 6) = 6$

**7**  $(1 \times 7) = 7$

**8**  $(1 \times 8) = 8$

**9**  $(1 \times 9) = 9$

**10**  $(1 \times 10) = 10$

**12**  $(1 \times 12) = 12$

**16**  $(1 \times 16) = 16$

# PARTS LIST

配件清单

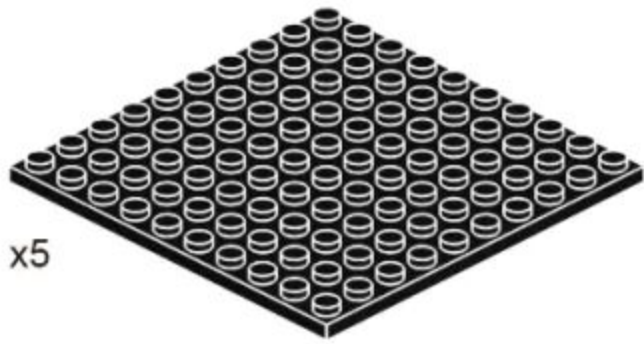

x5

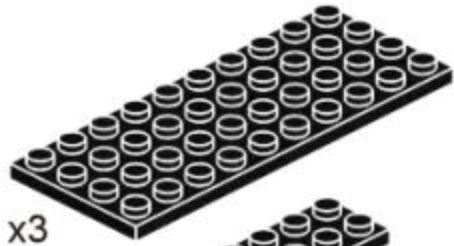

x3



x1



x1



x2



x1



x2



x7



x1



x7



x1



x34



x9



x355



x4



x5



x2



x5



x2



x2



x1



x1



x4



x1



x1



x2



x8



x2



x2



x5

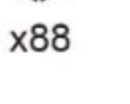

x88



x10

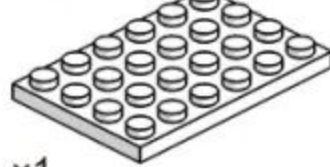

x1



x6



x7



x2

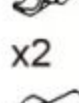

x4



x4



x11



x2



x1



x1



x1



x1



x1



x14



x1



x8



x1



x4

# PARTS LIST

配件清单

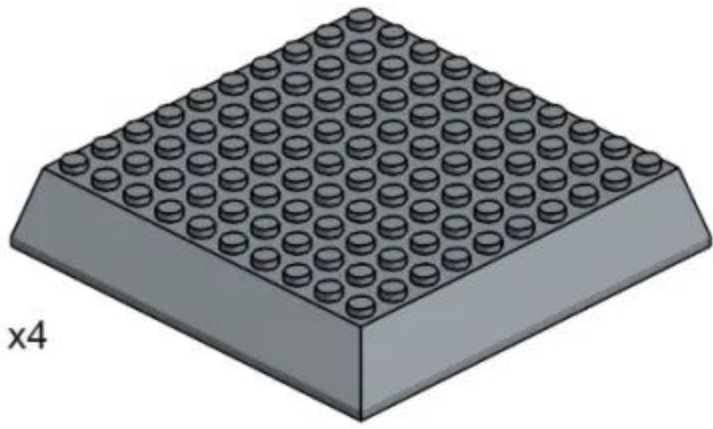

x4



x8



x4



x12



x12



x4



x4



x4

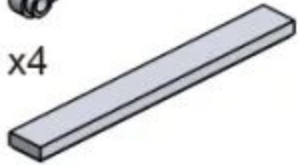

x8

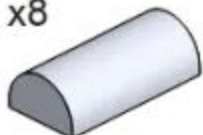

x1



x4



x4



x1



x19



x1

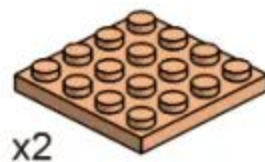

x2



x2



x5



x1



x3



x1



x1



x1



x2



x2



x1



x6



x9



x3



x4



x2



x19



x1



x1



x2



x2



x2



x1



x3



x2



x55



x345



x5



x1



x3



x1



x2



x1



x4



x14

产品有增补件请以实物为准  
If product has additional parts, please in kind prevail.



239PCS

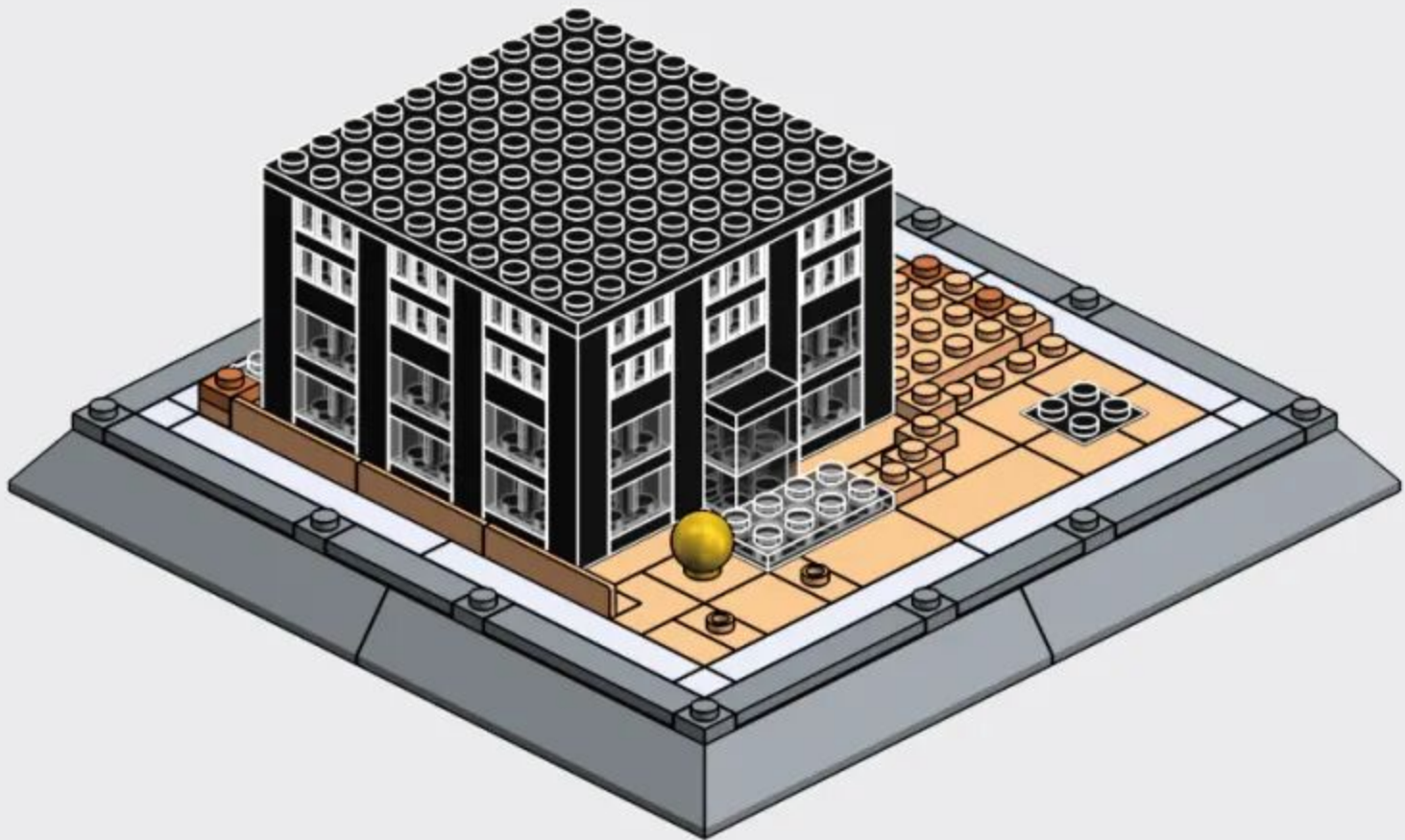

1-1

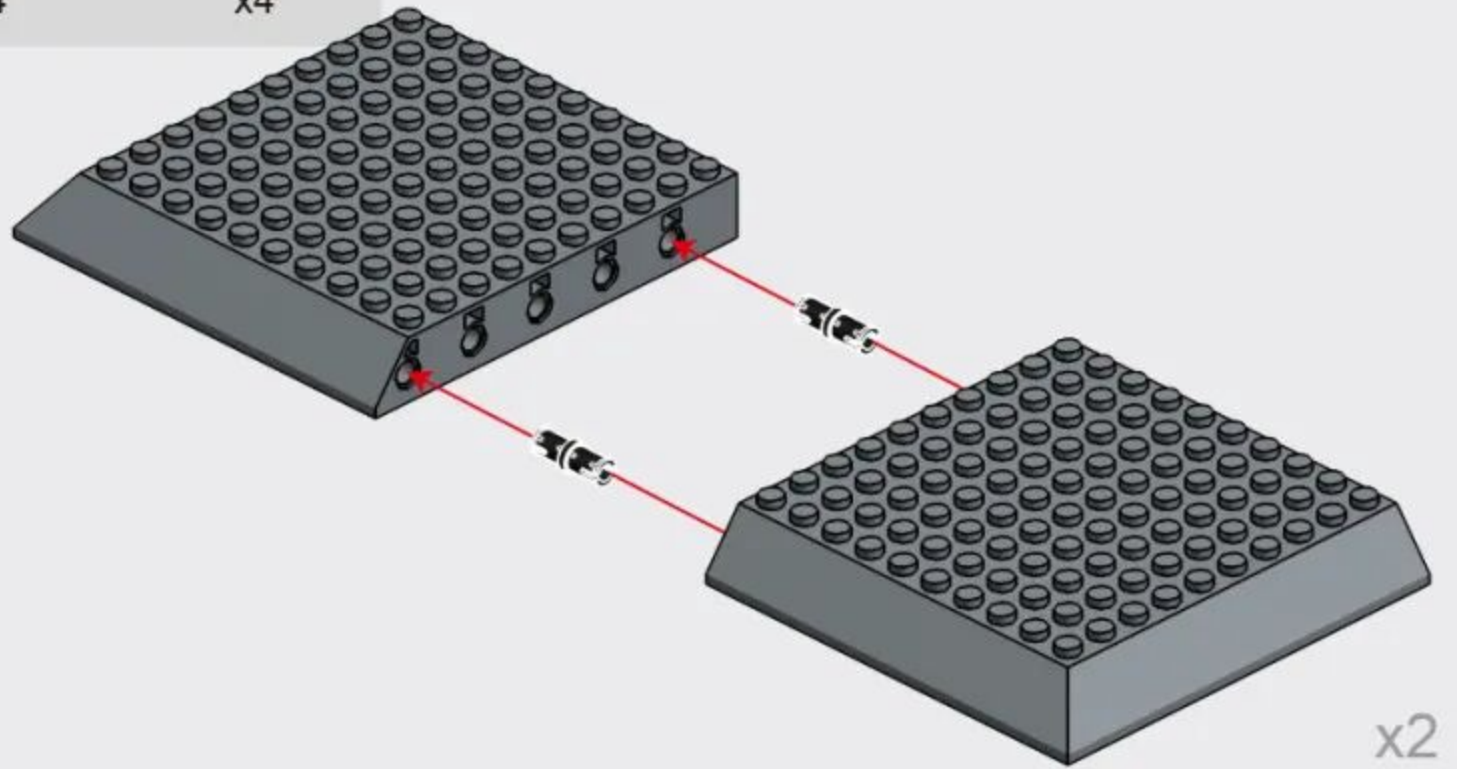
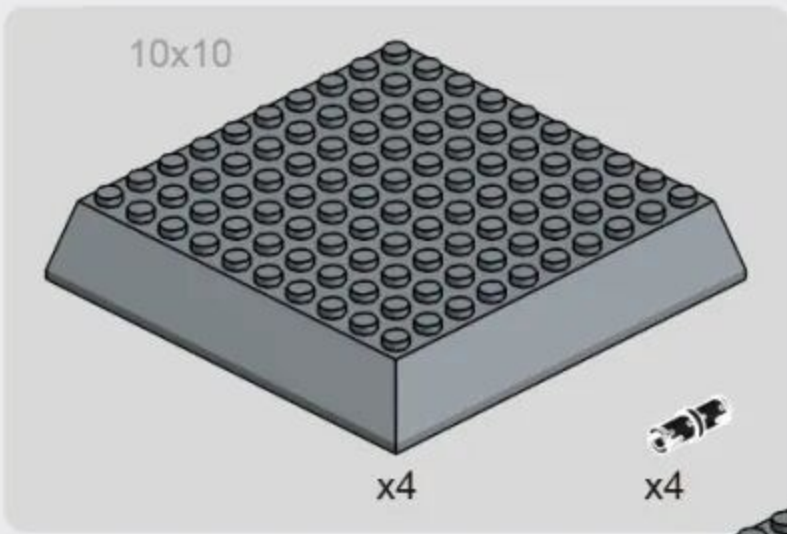

1-2

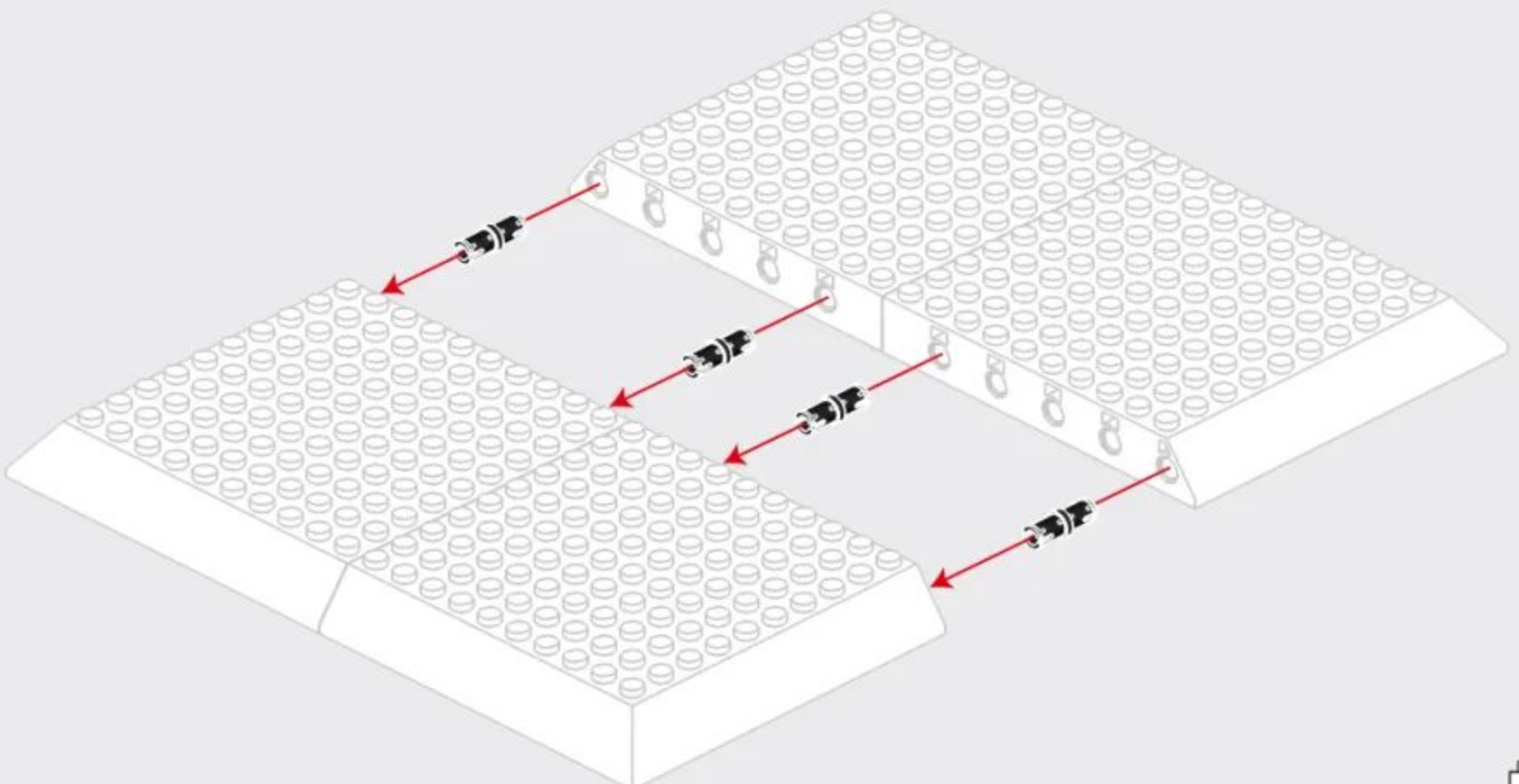

### 1-3

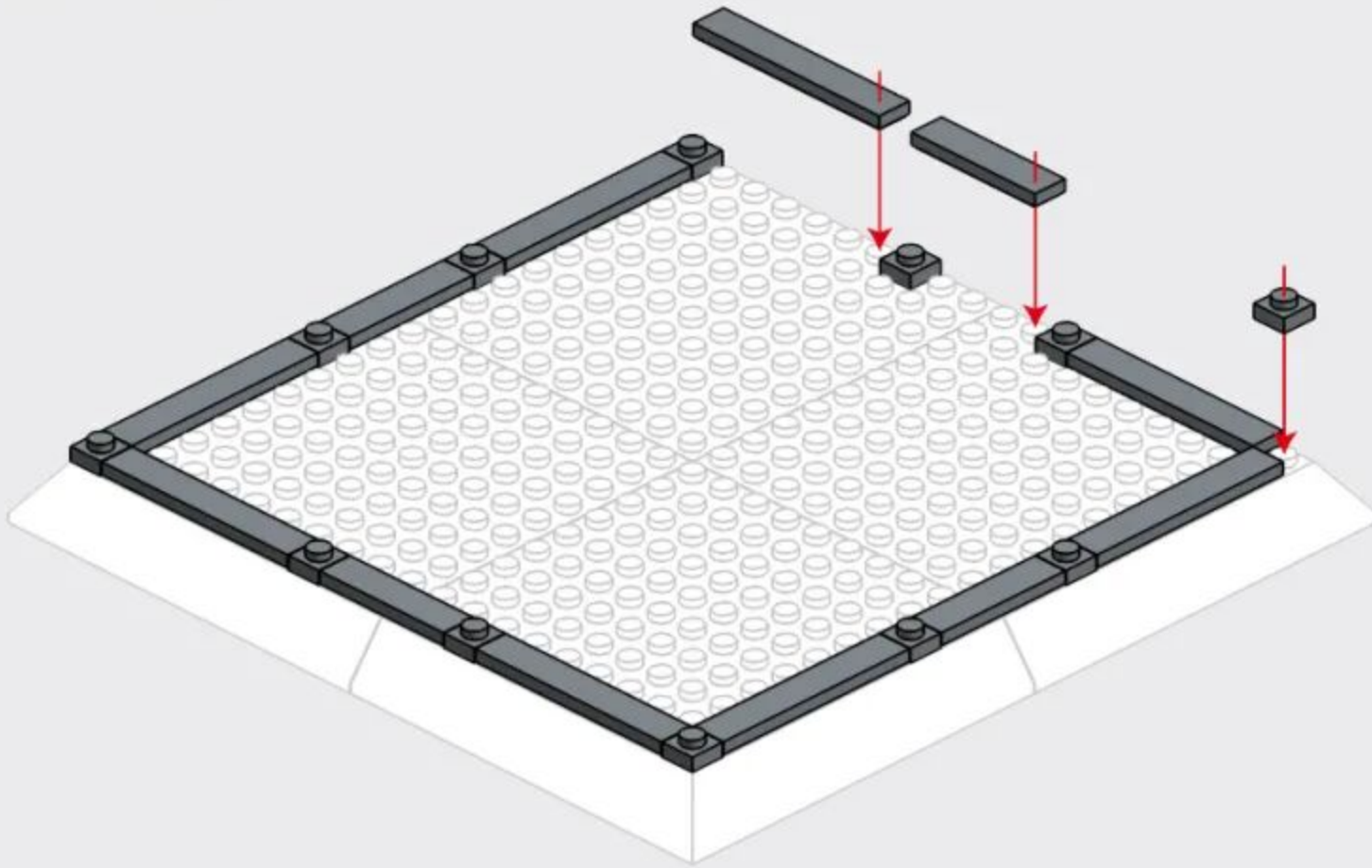
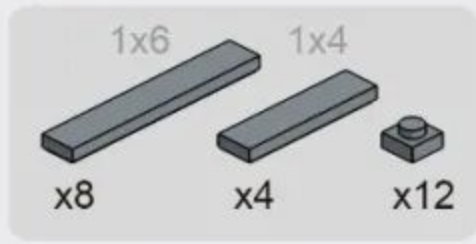

### 1-4

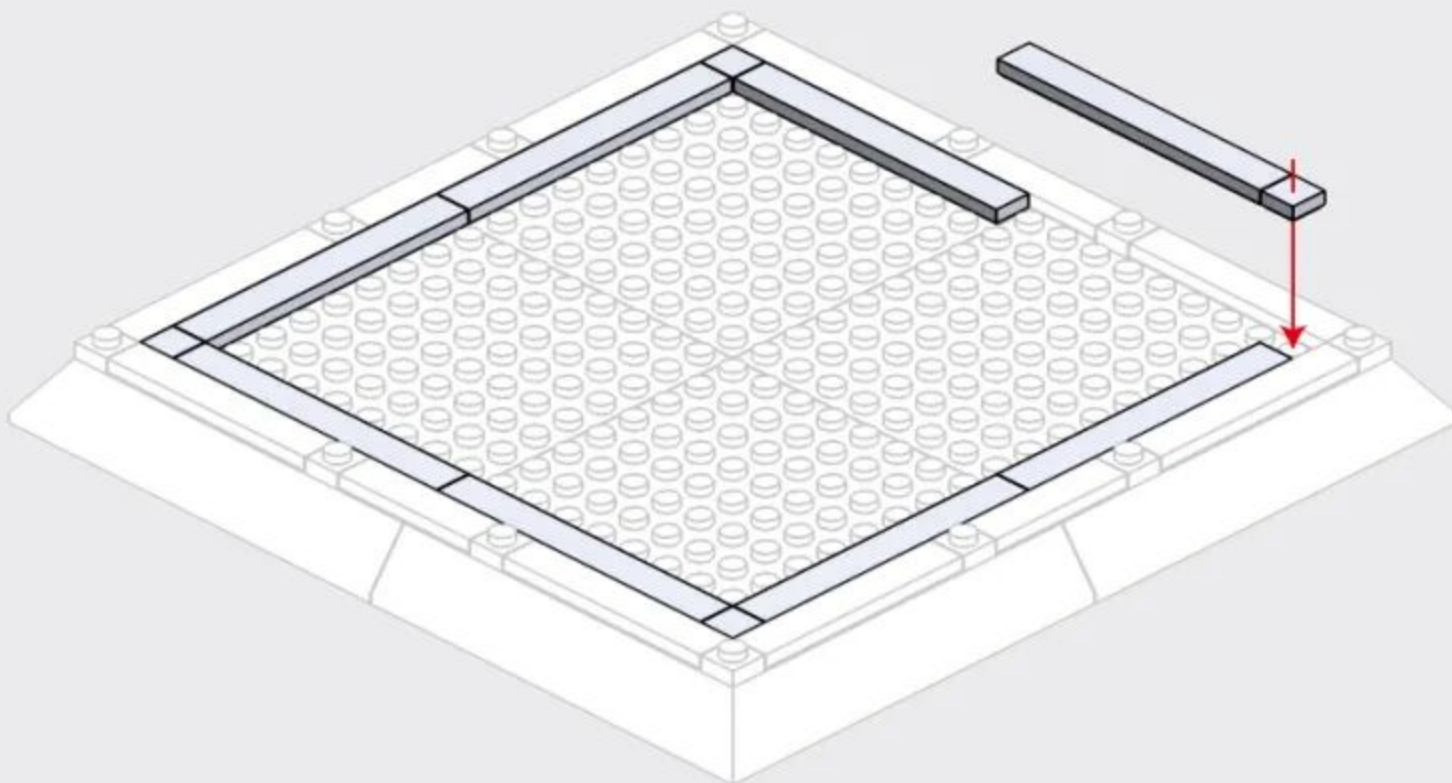
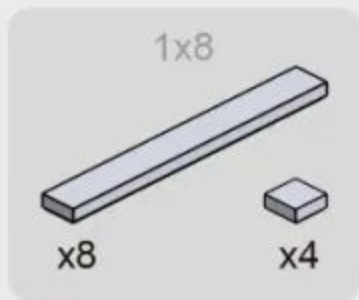

# 1-5

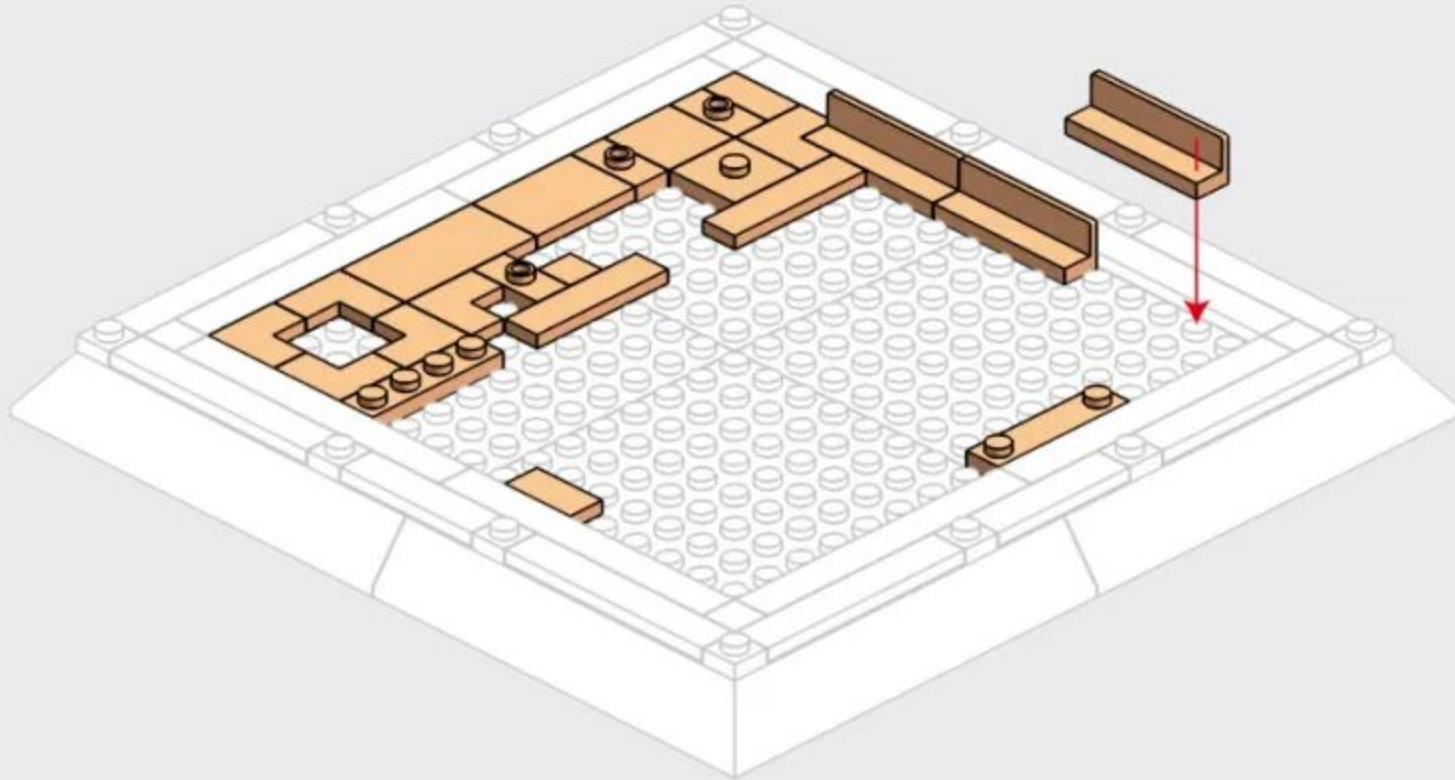
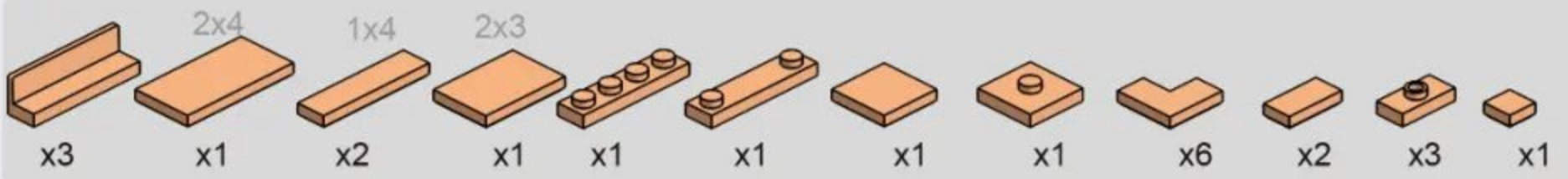

# 1-6

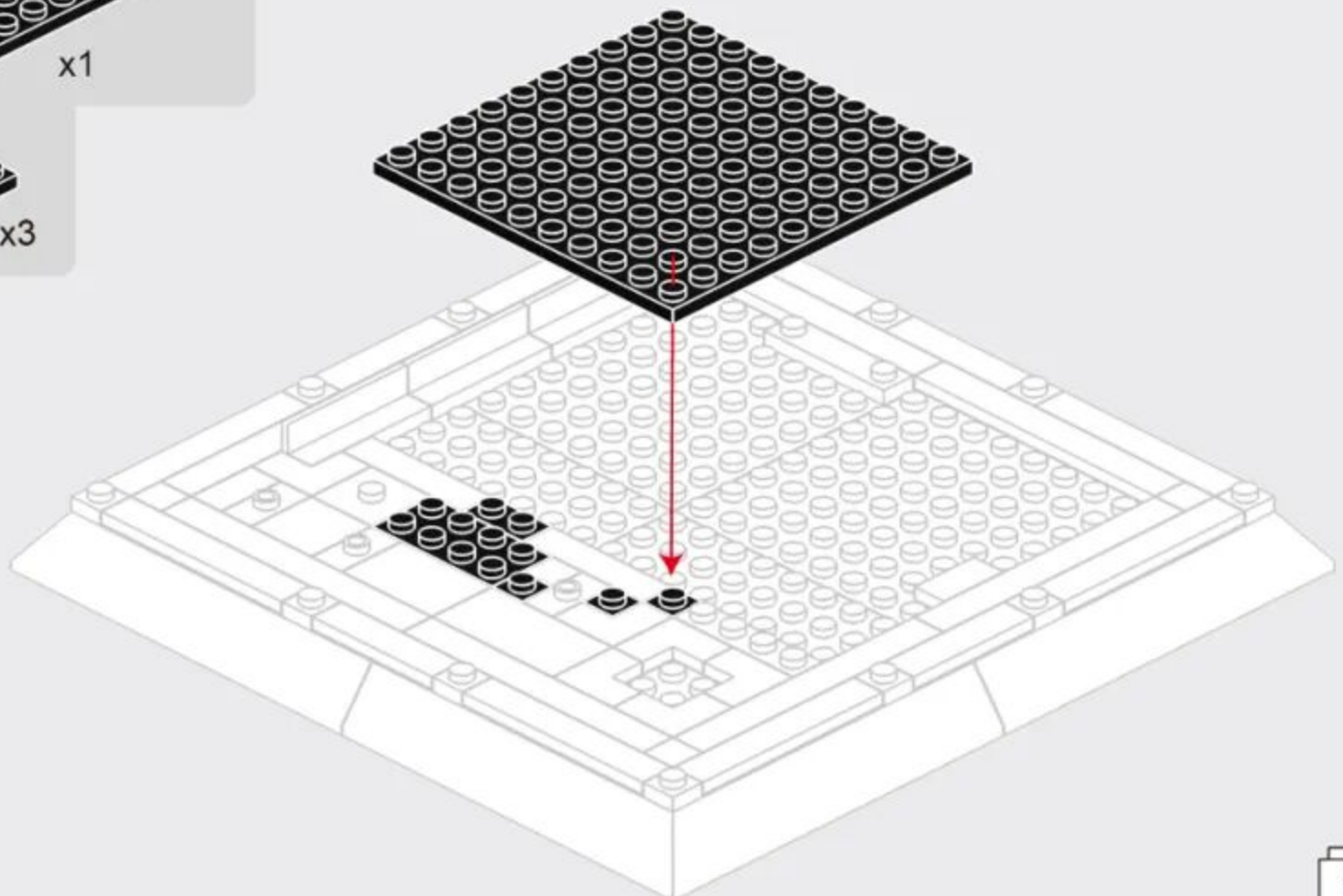
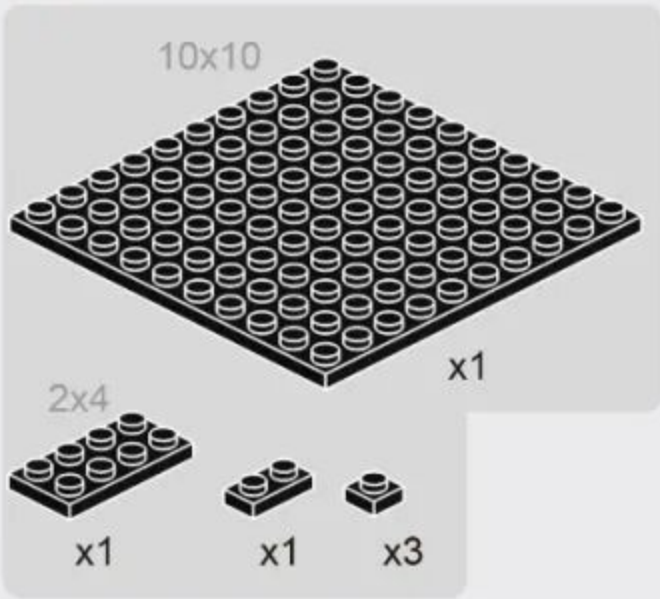

# 1-7

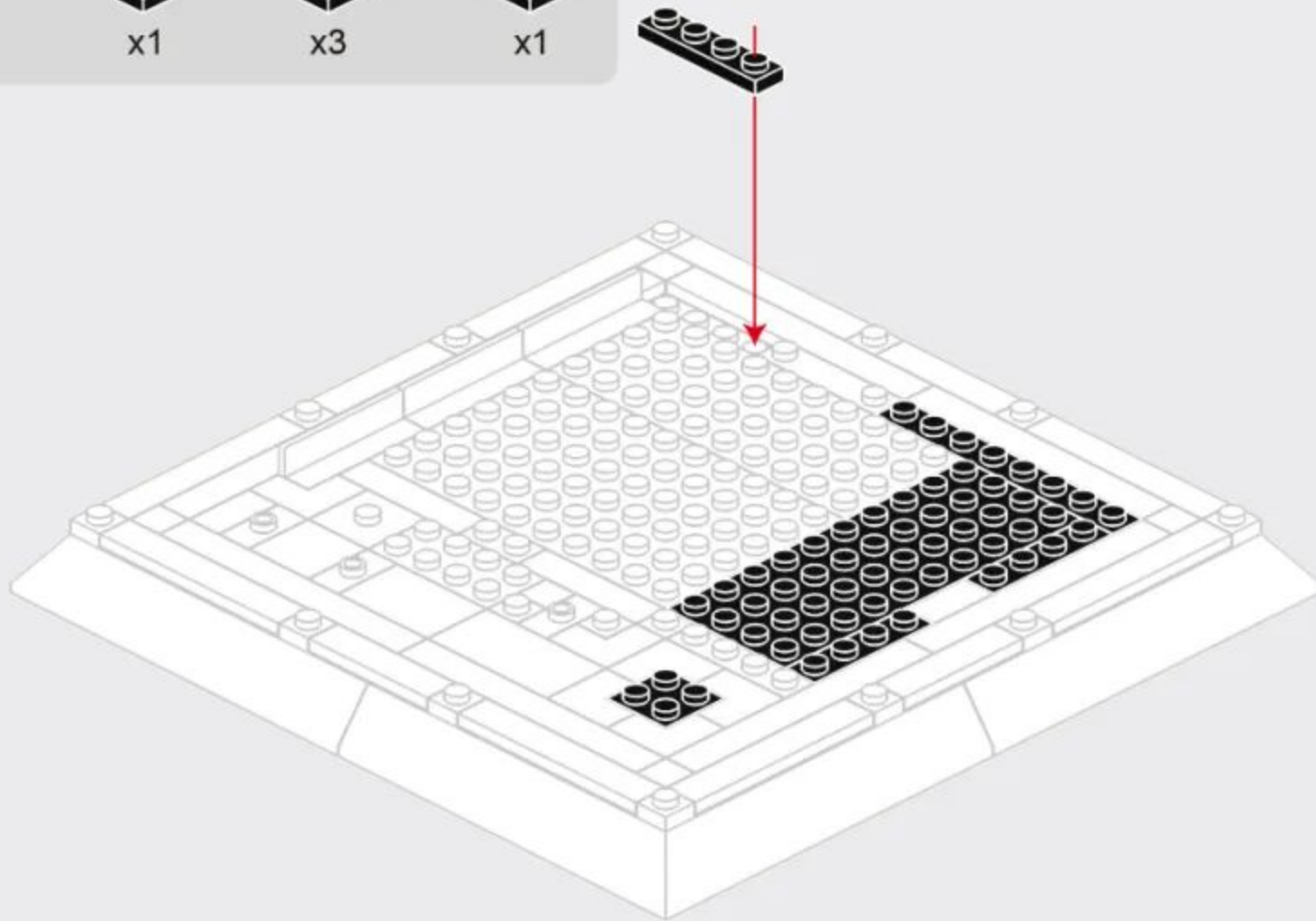
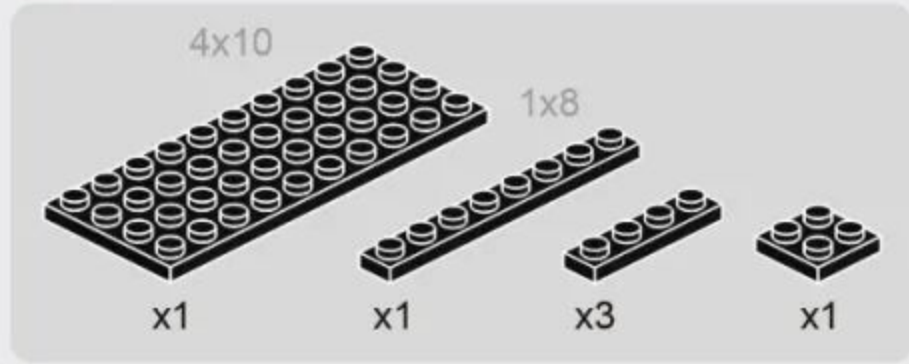

# 1-8

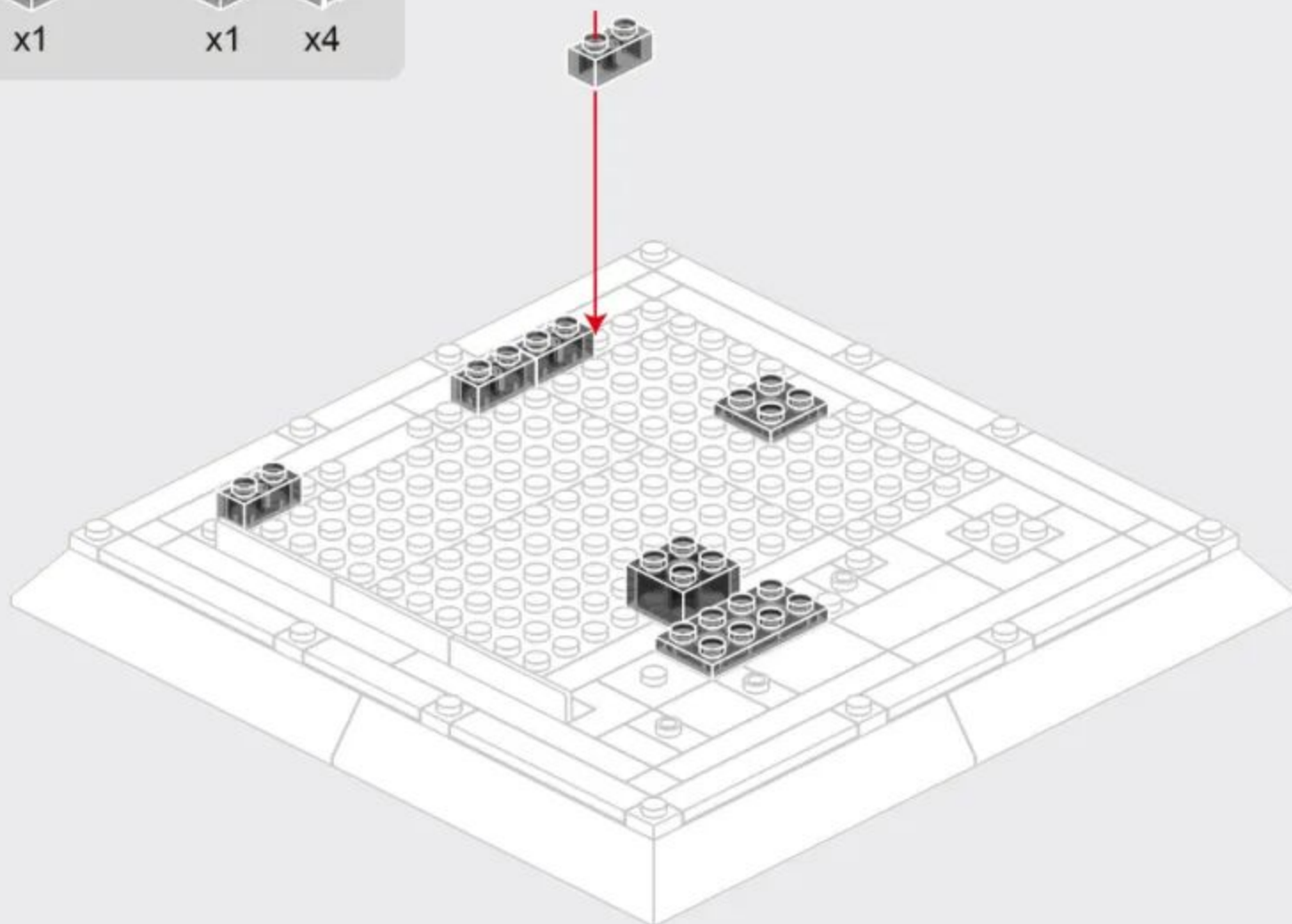
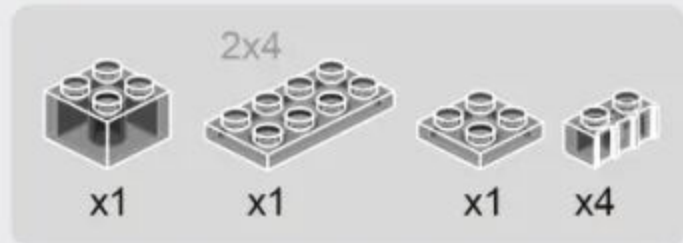

# 1-9

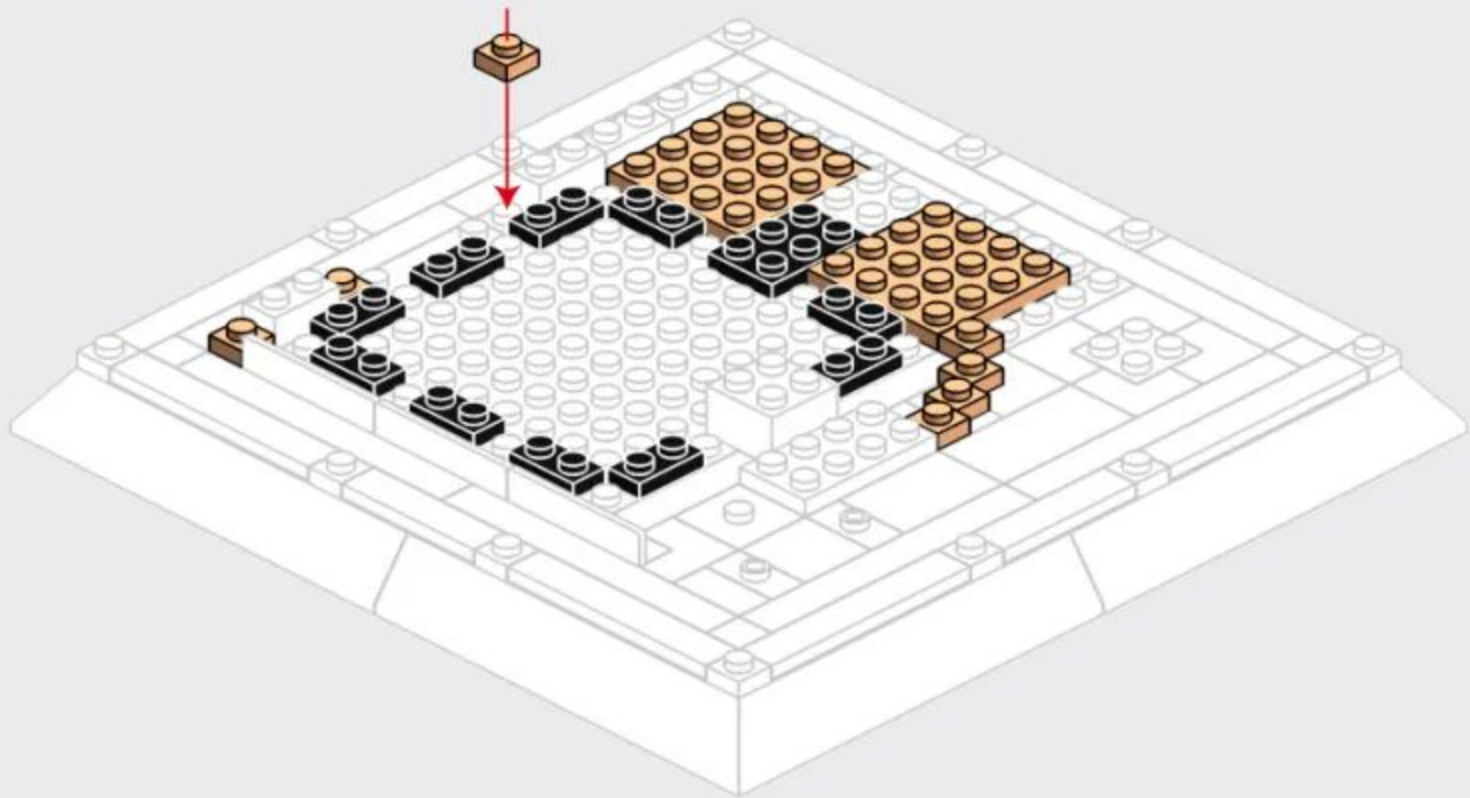
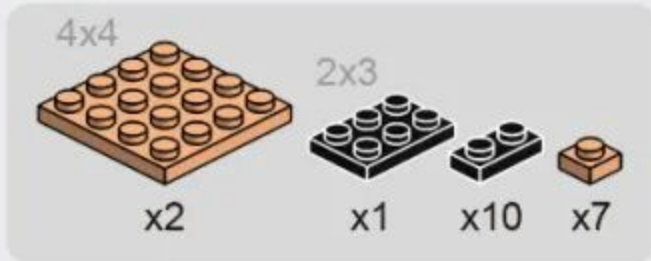

# 1-10

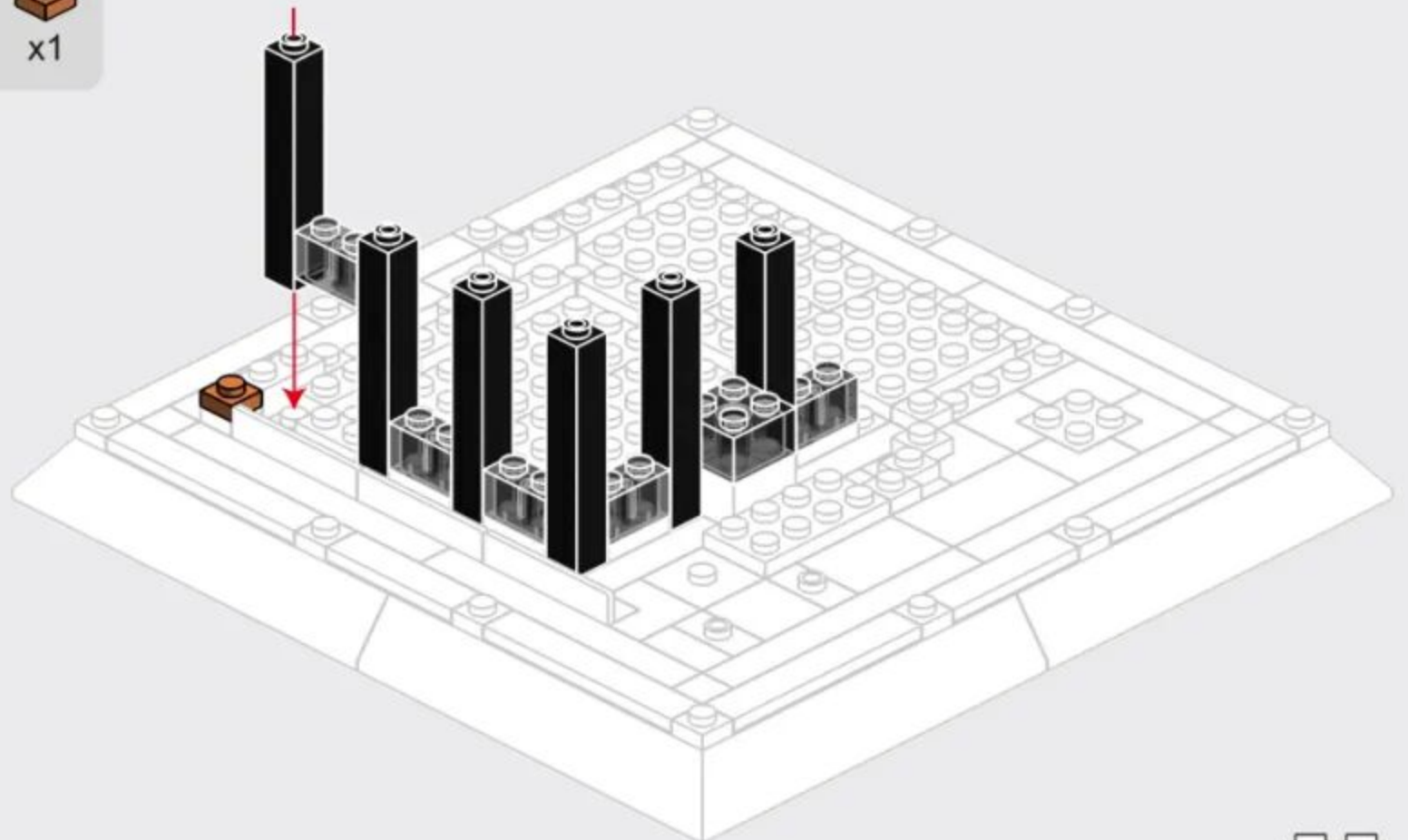
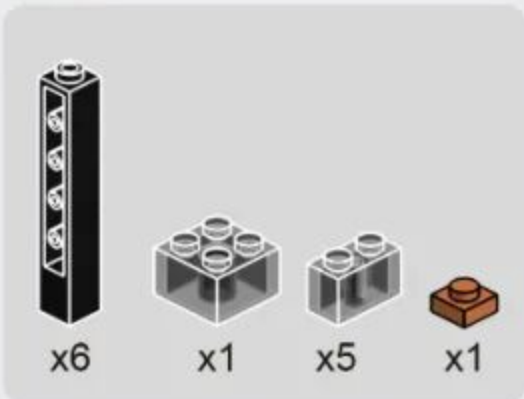

# 1-11

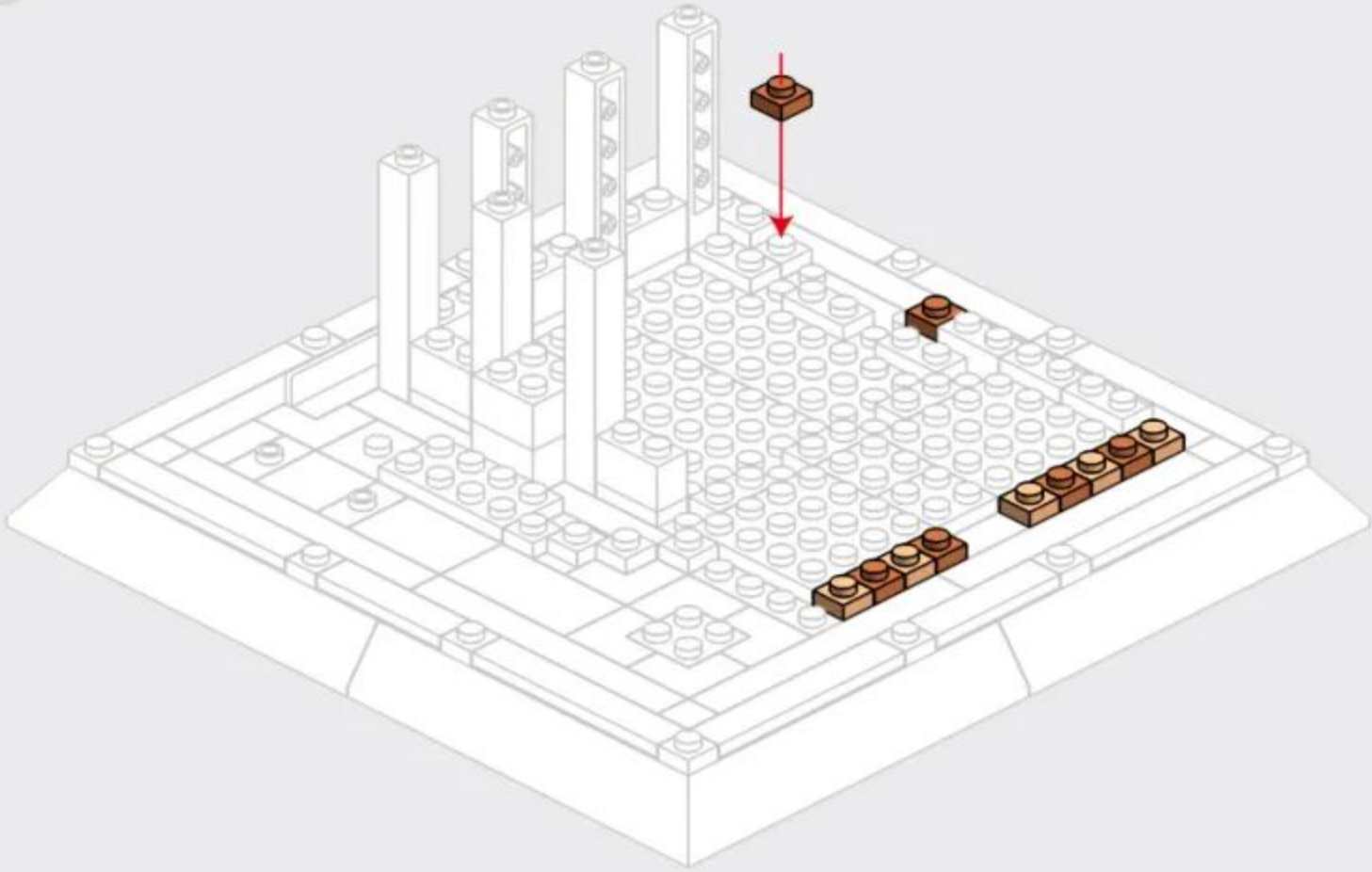

# 1-12

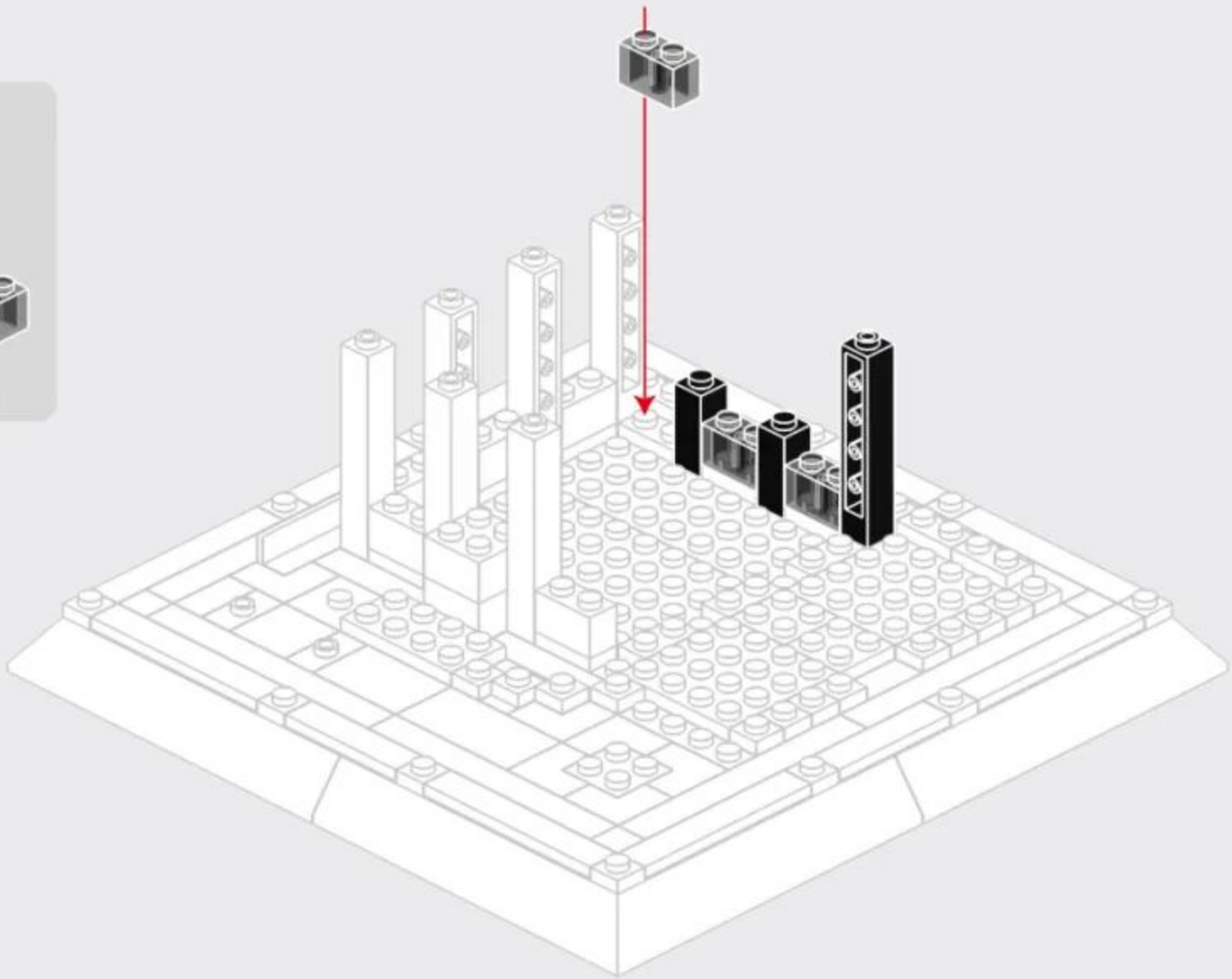
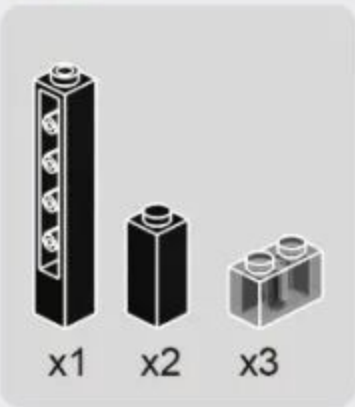

1-13

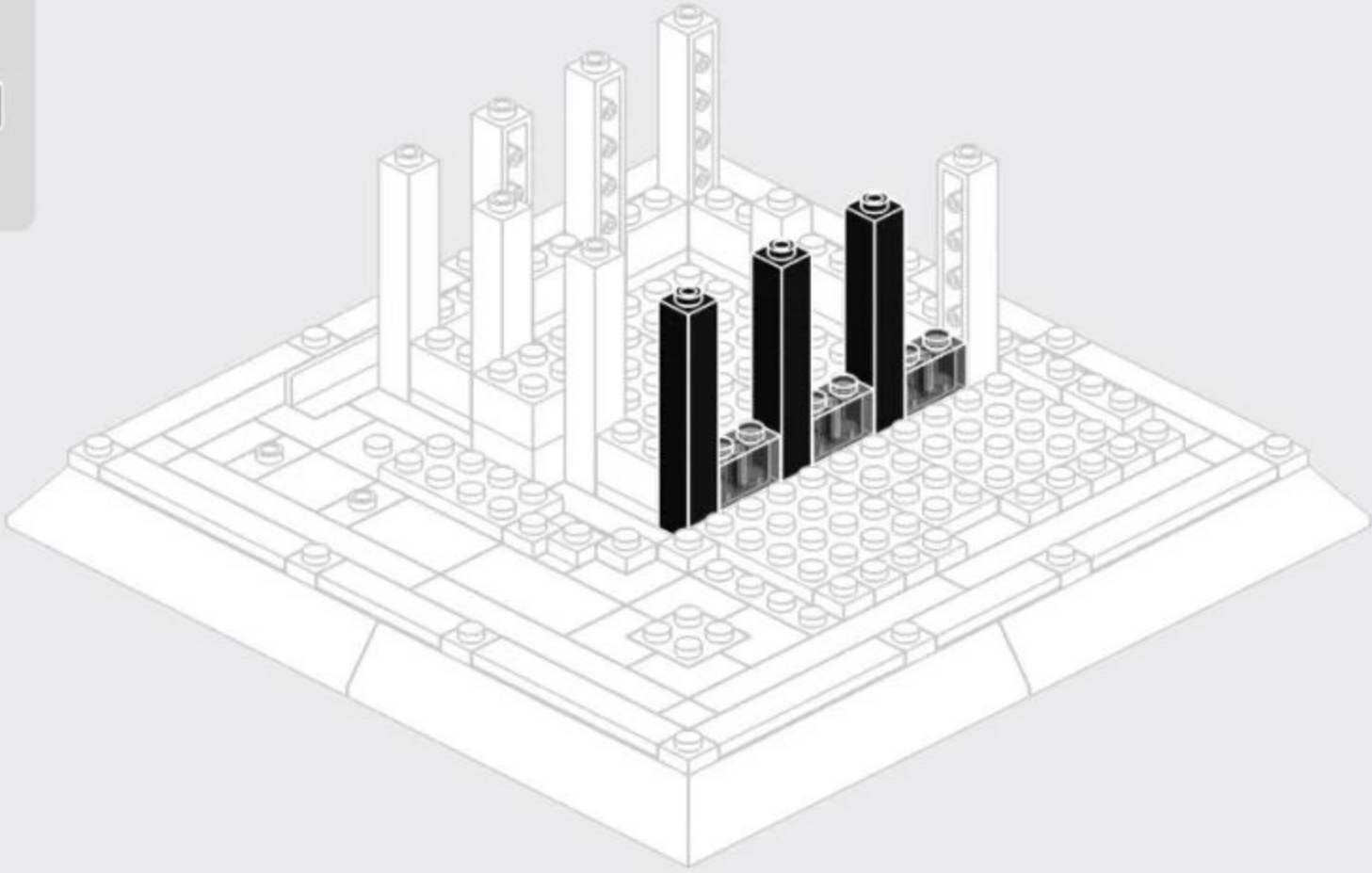
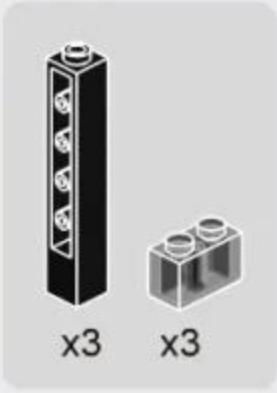

1-14

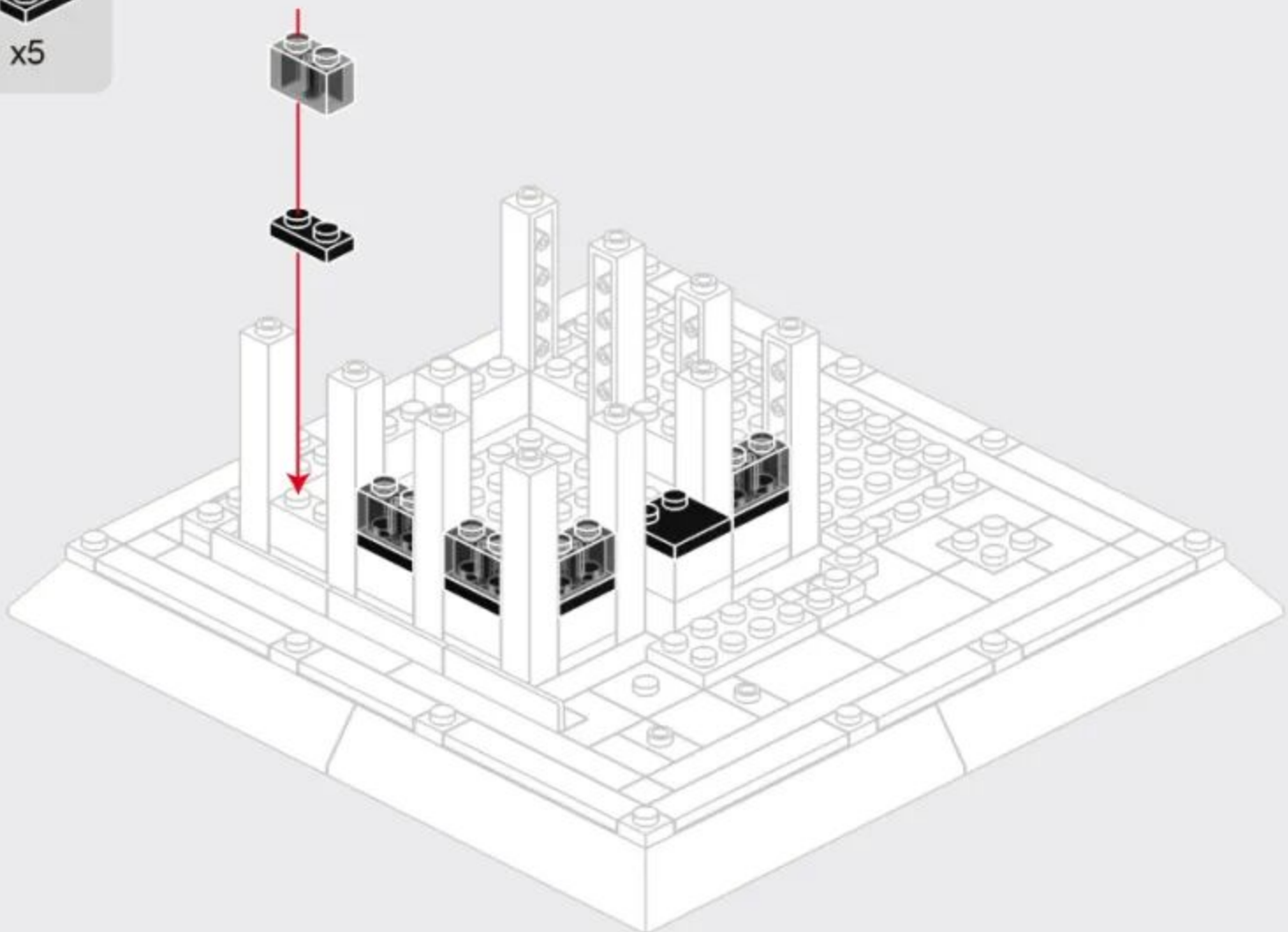
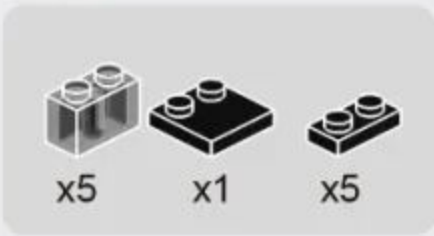

1-15

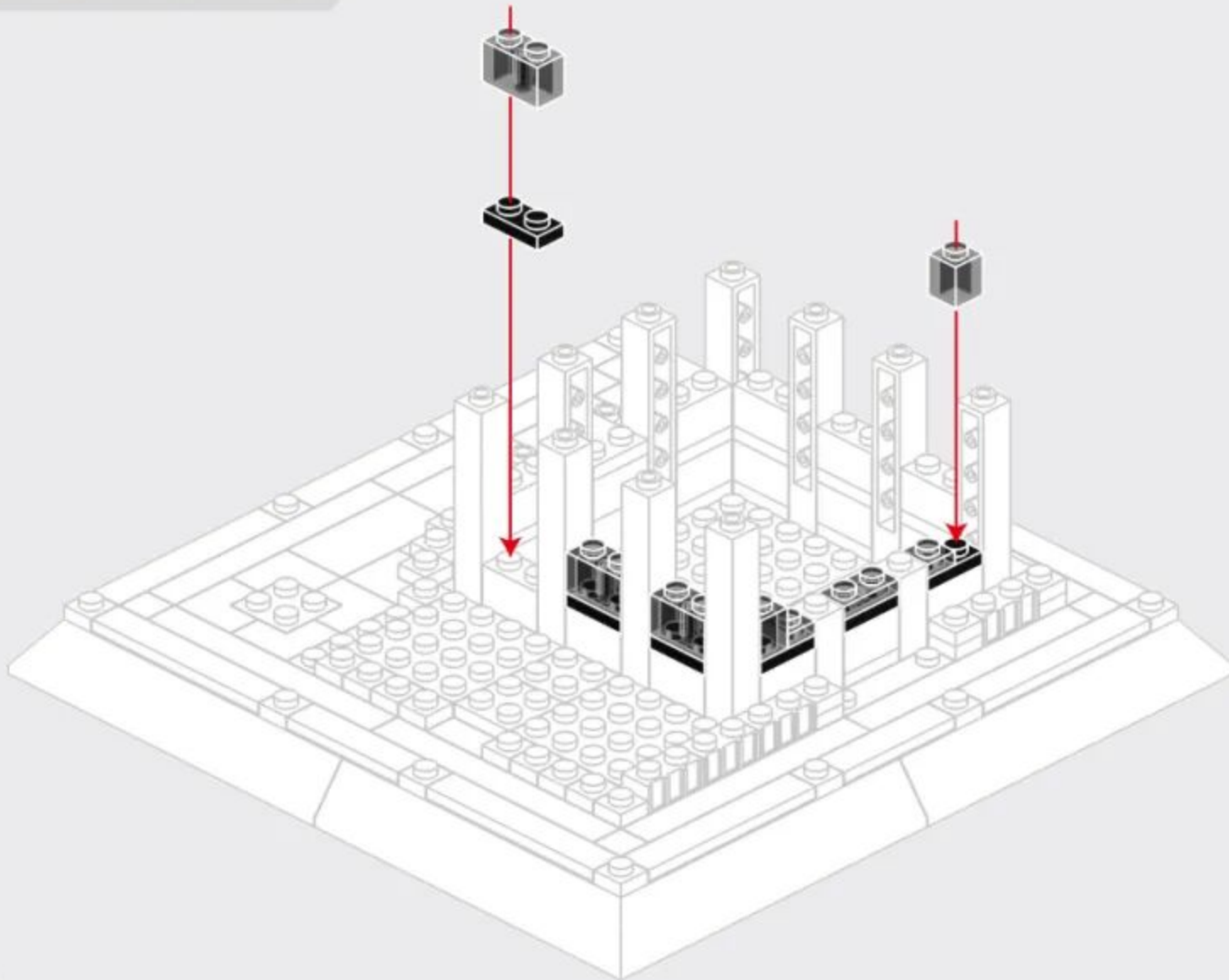

1-16

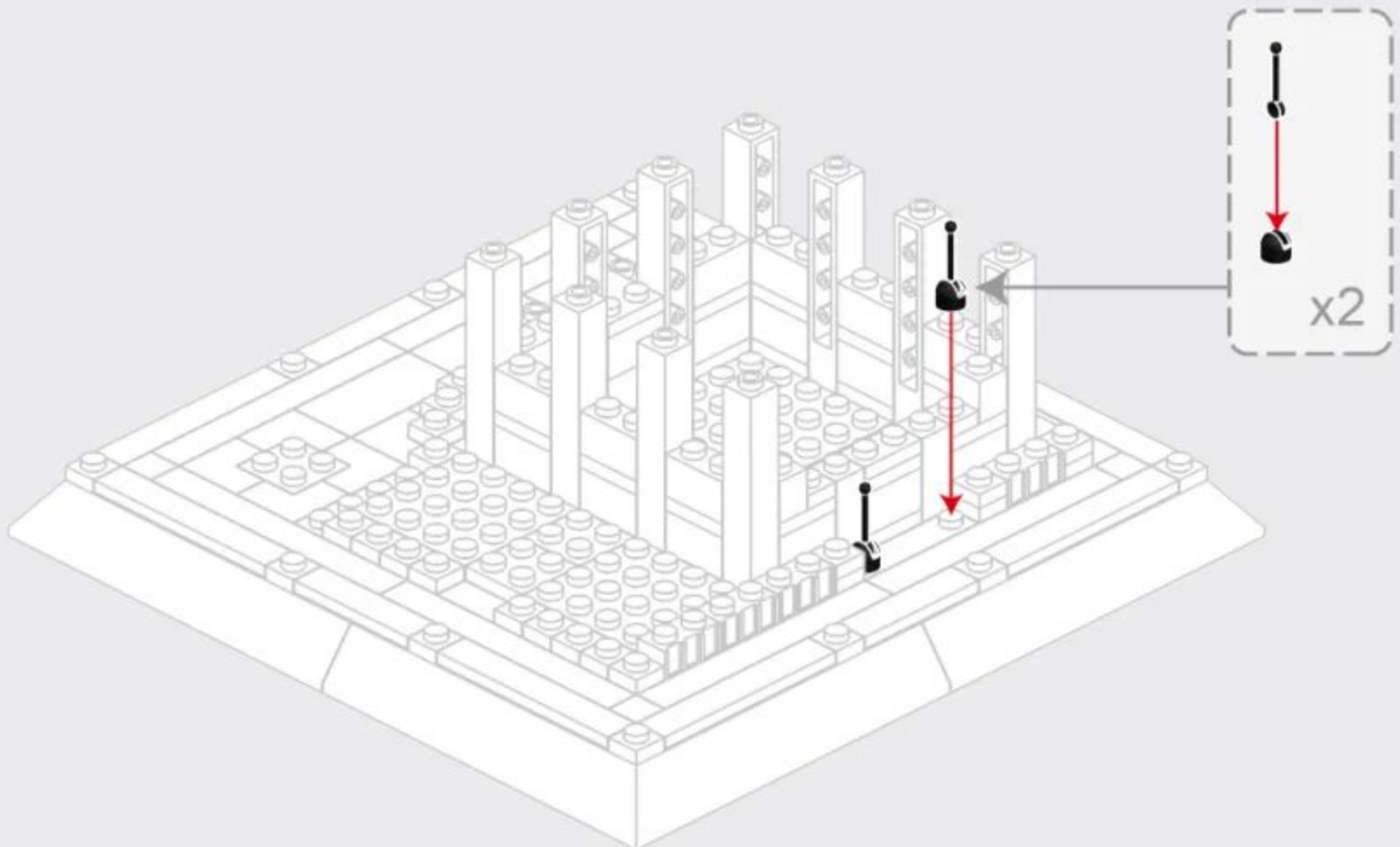

# 1-17

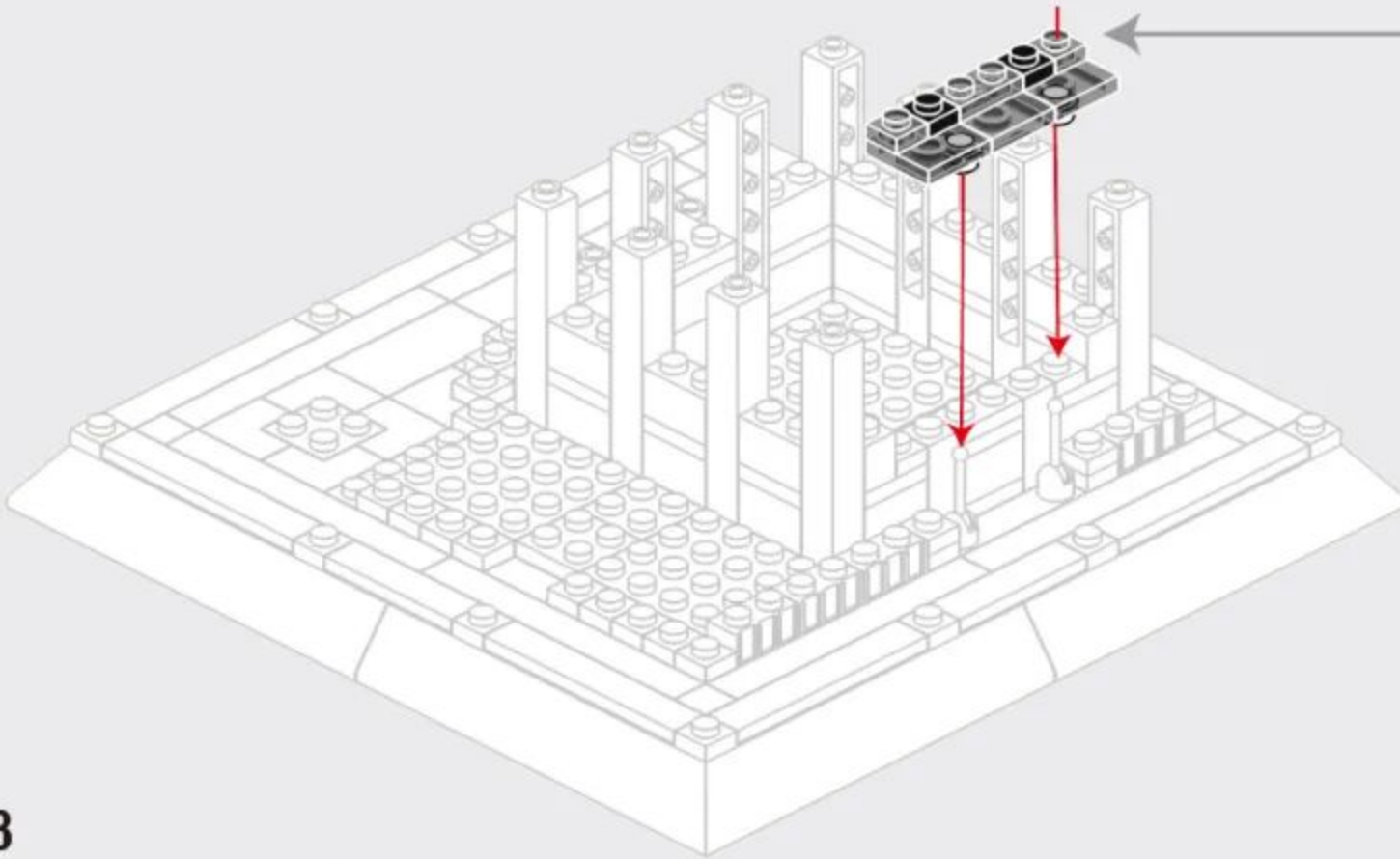
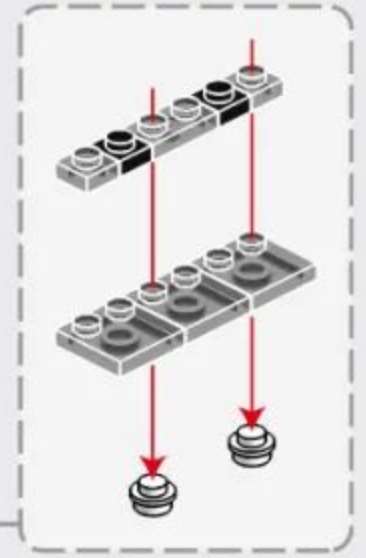

# 1-18

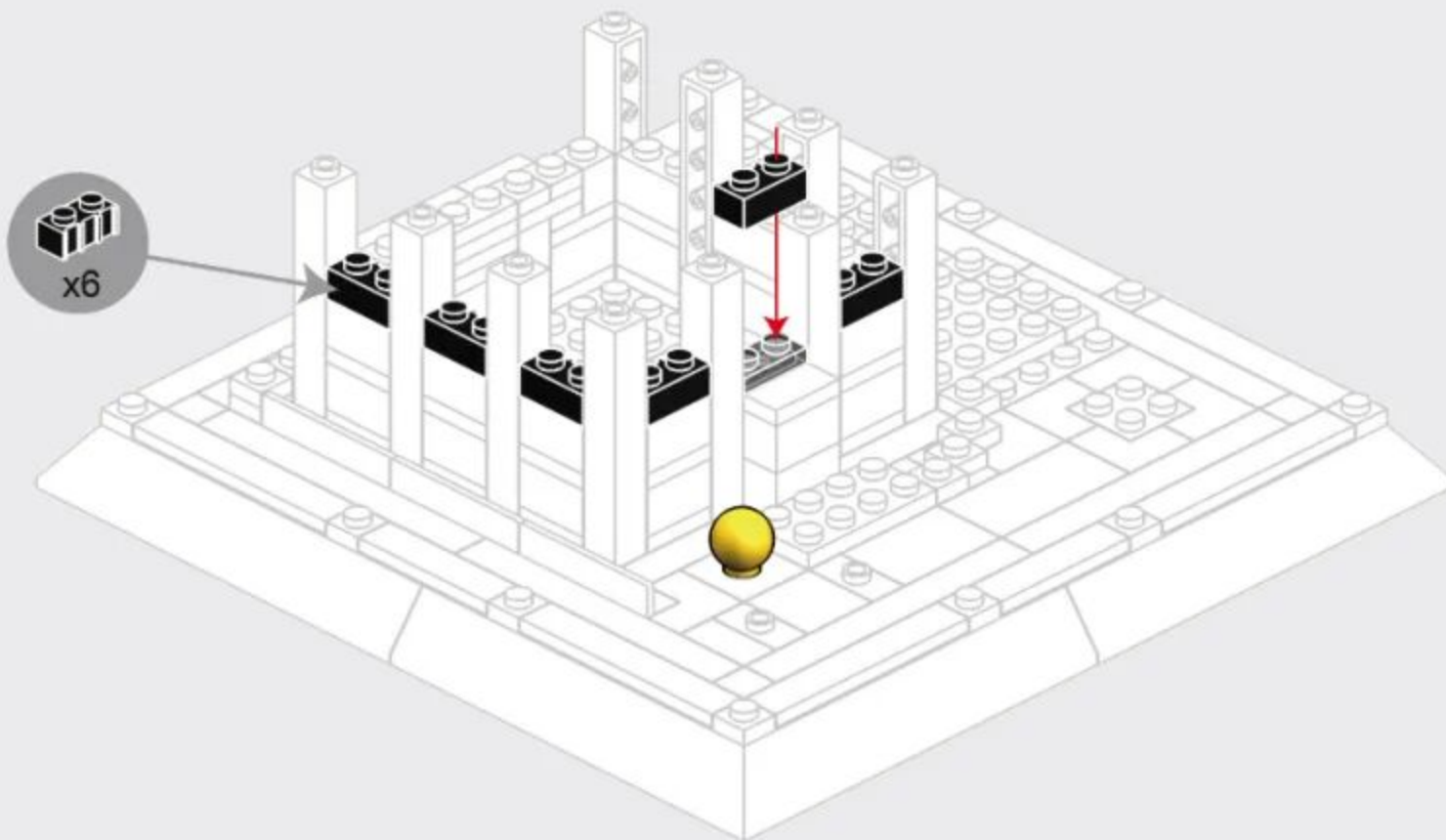

# 1-19

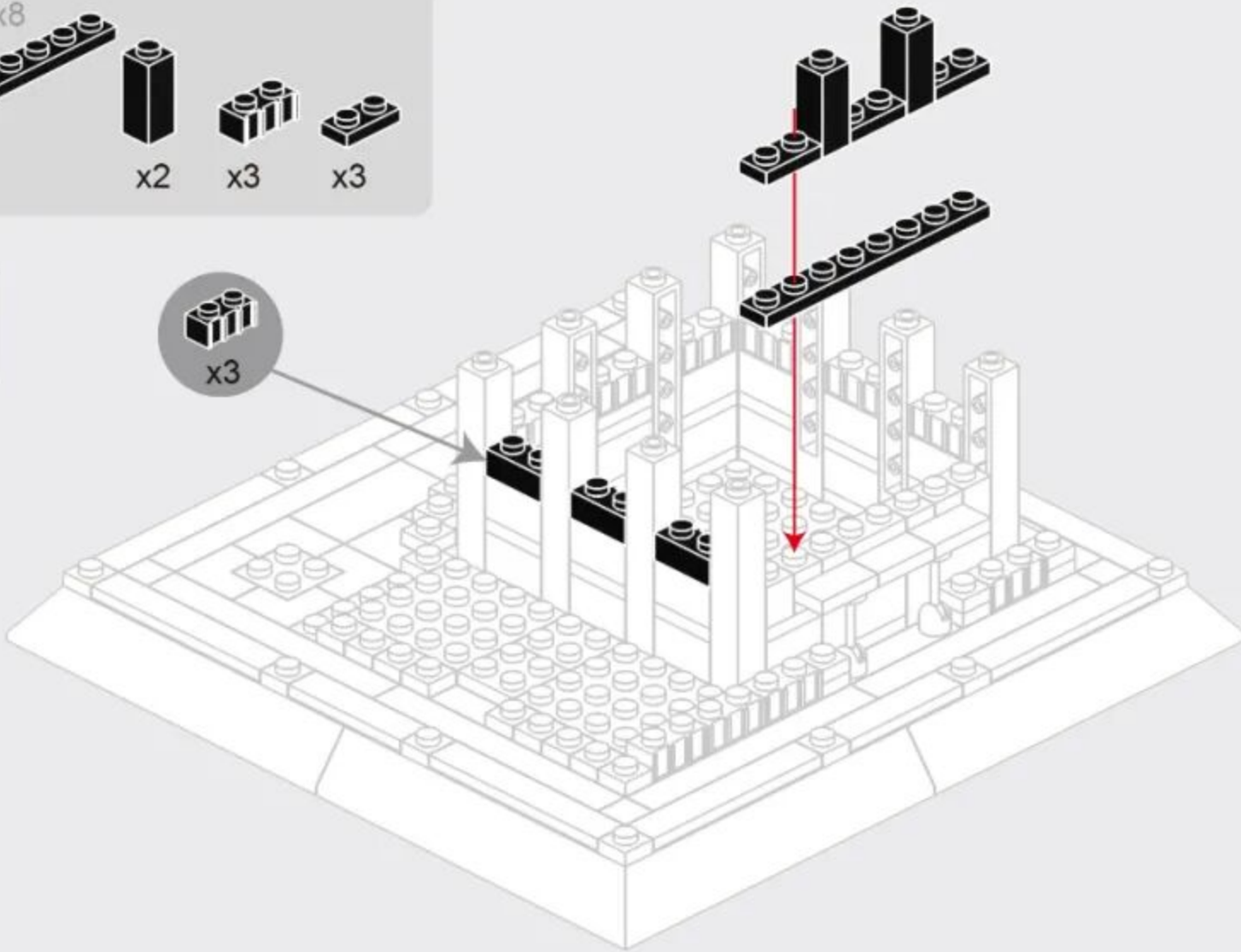
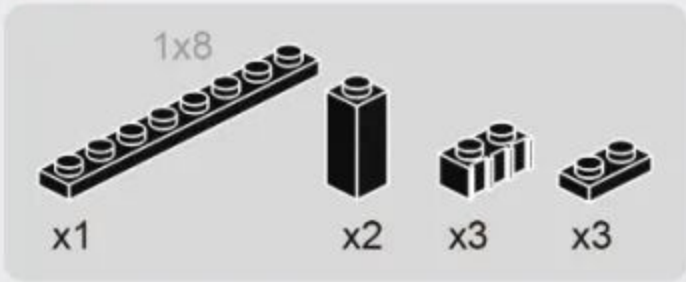

# 1-20

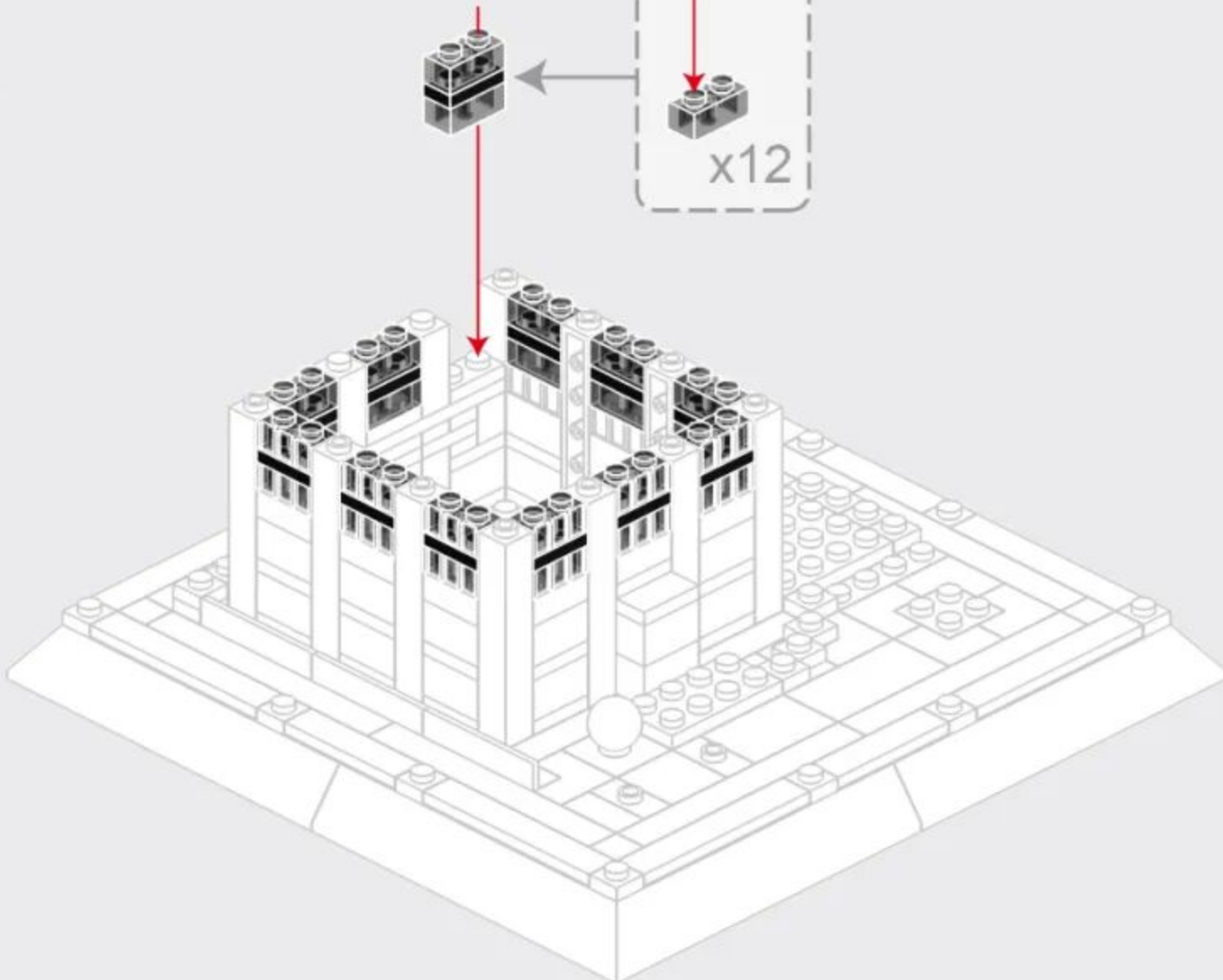
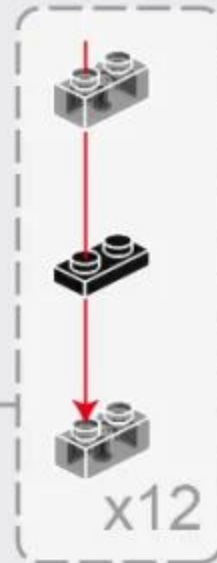

1-21

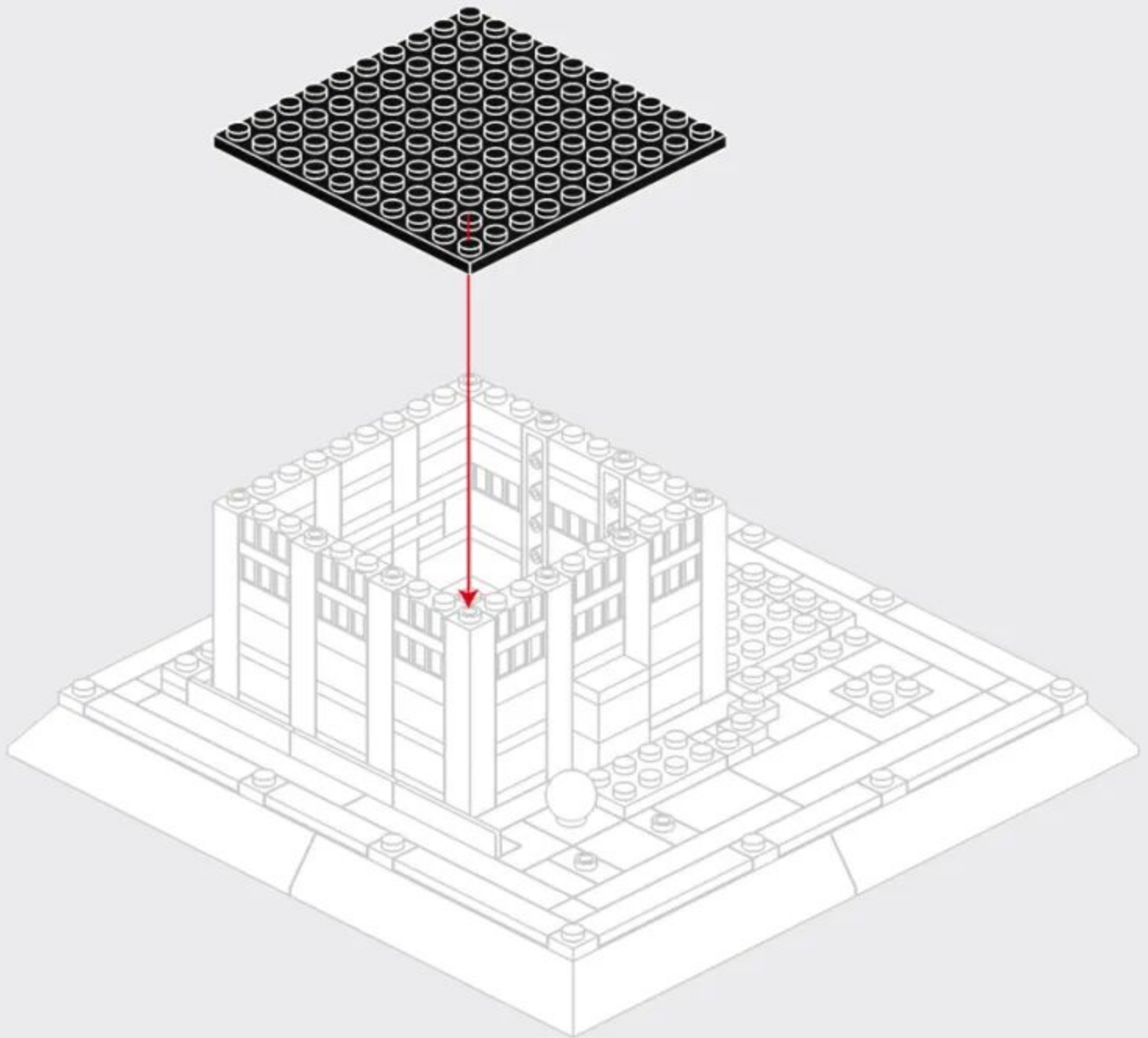
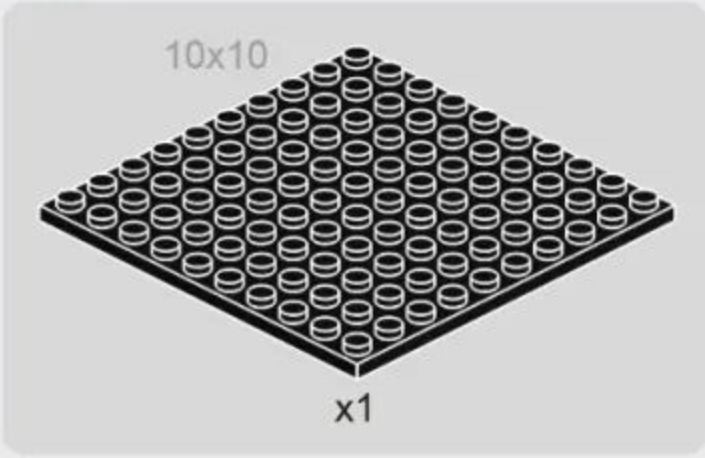



242PCS

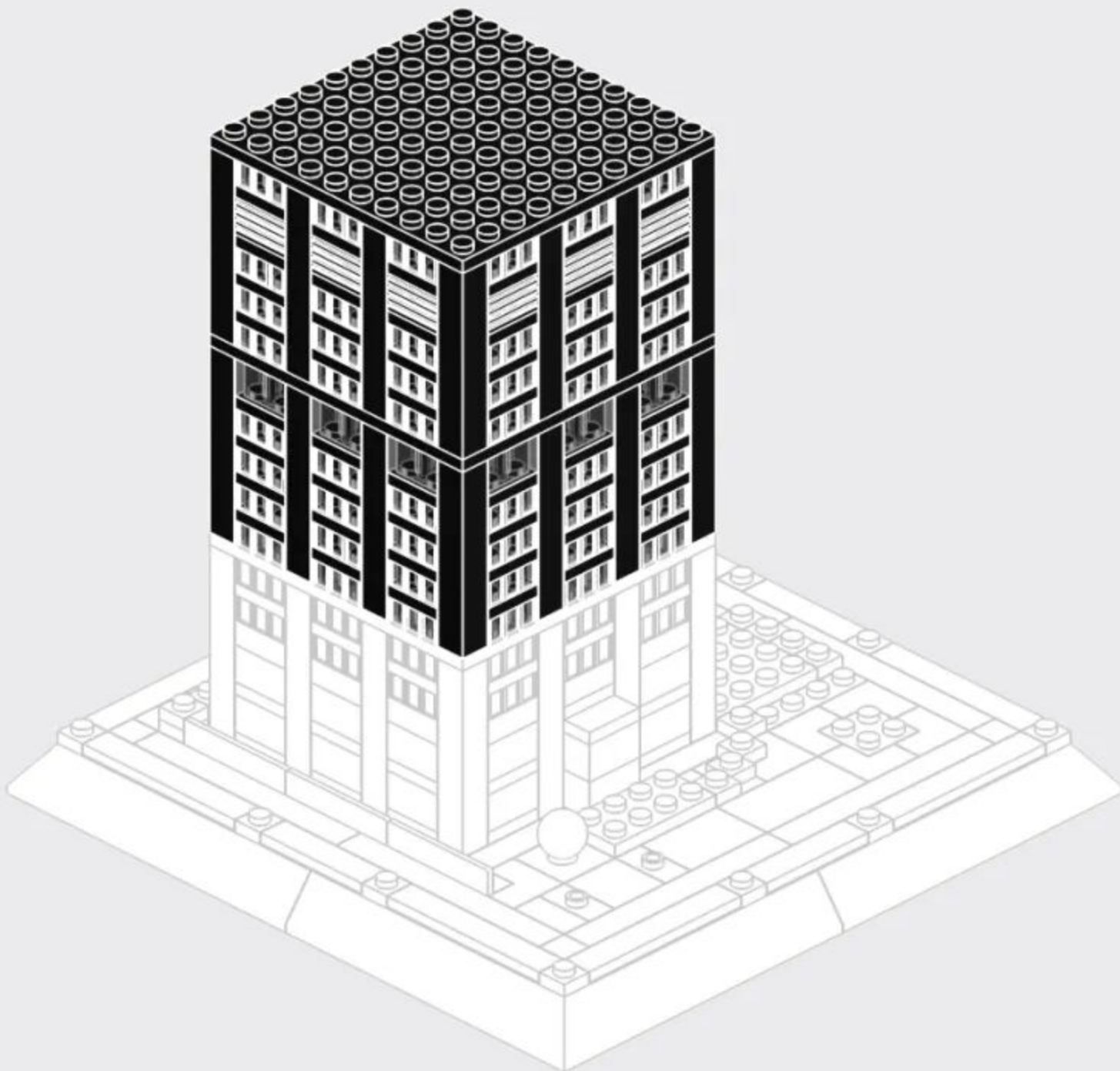

2-1

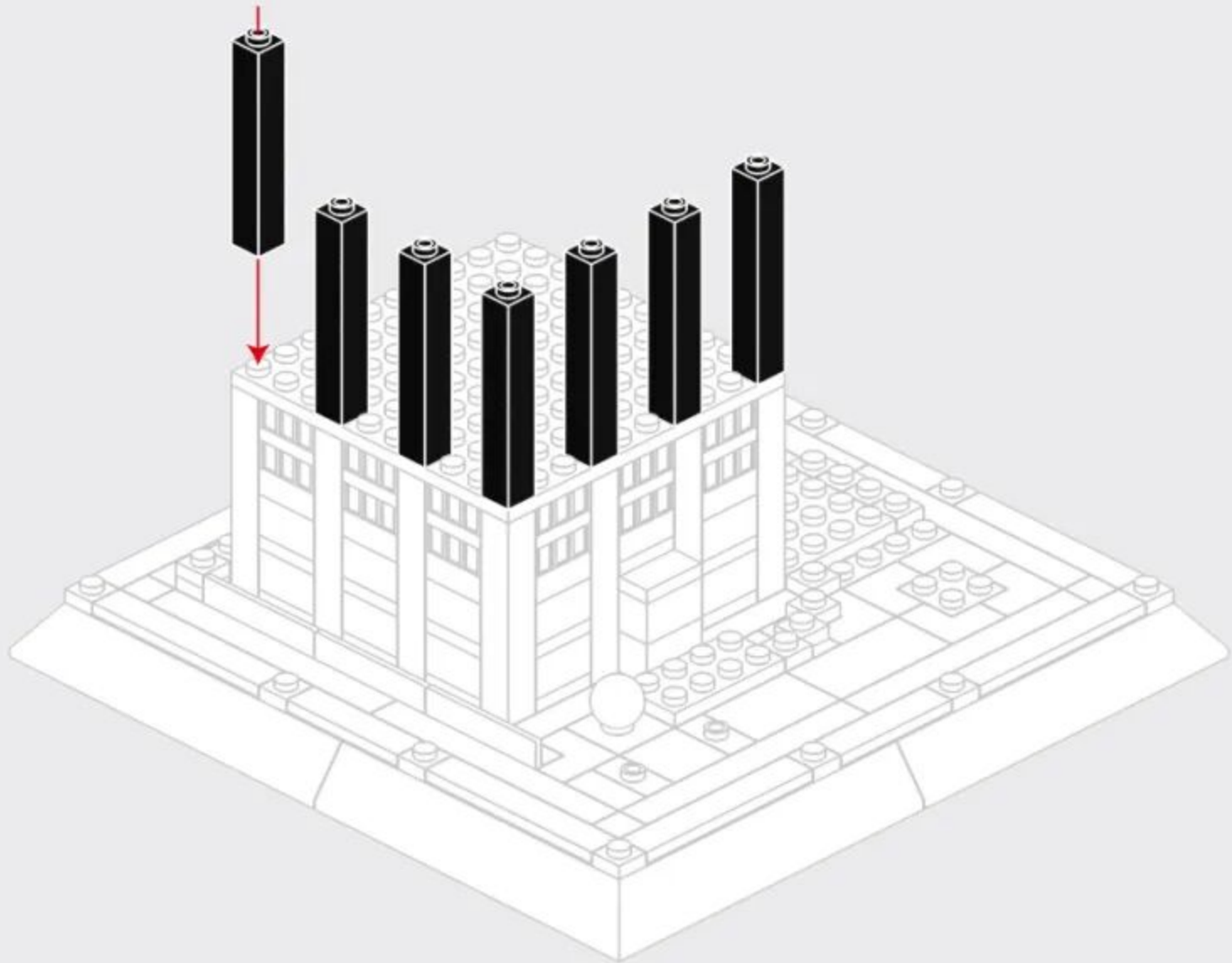

2-2

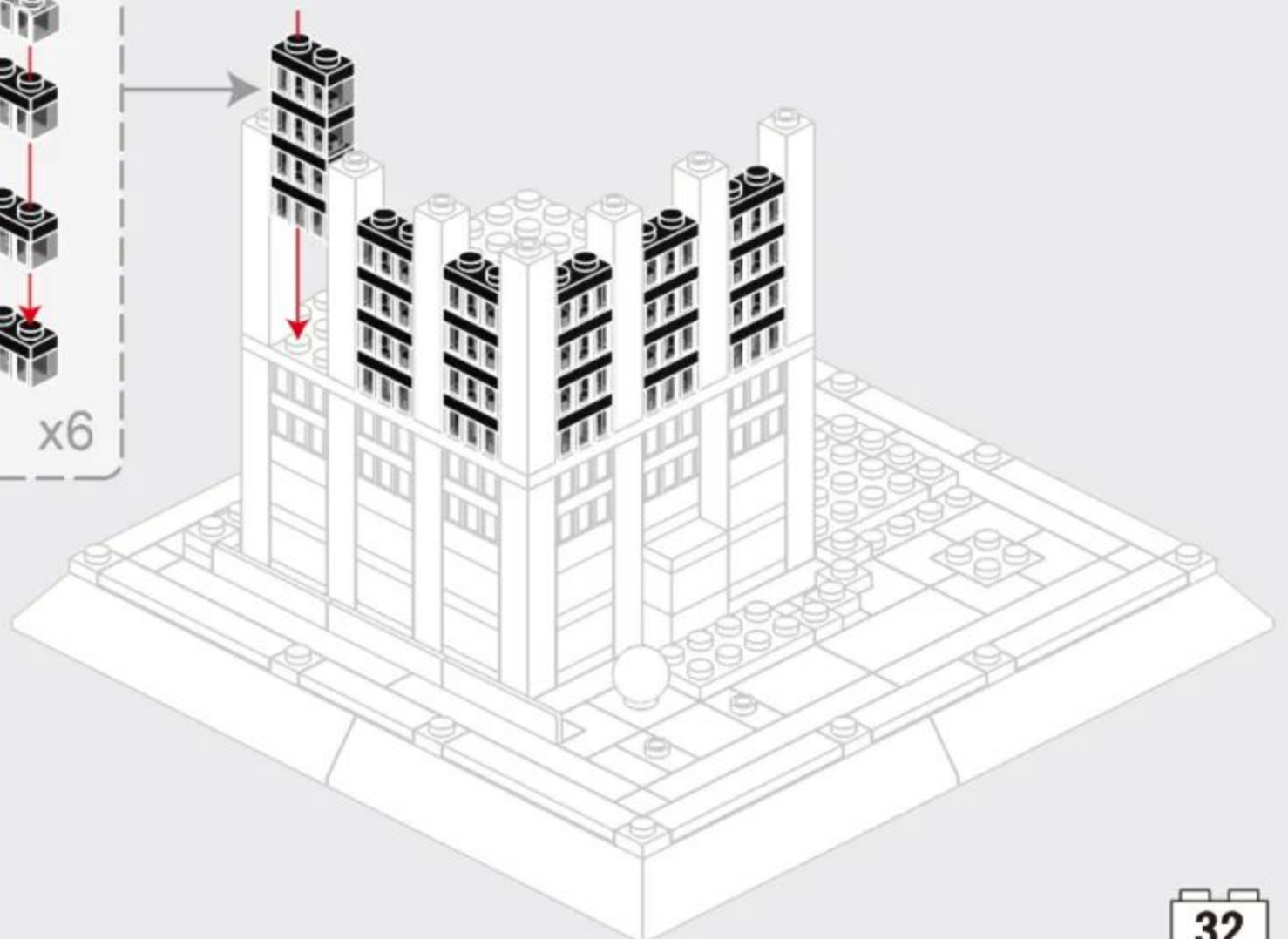
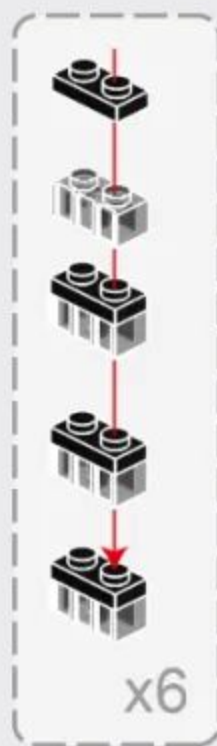

2-3

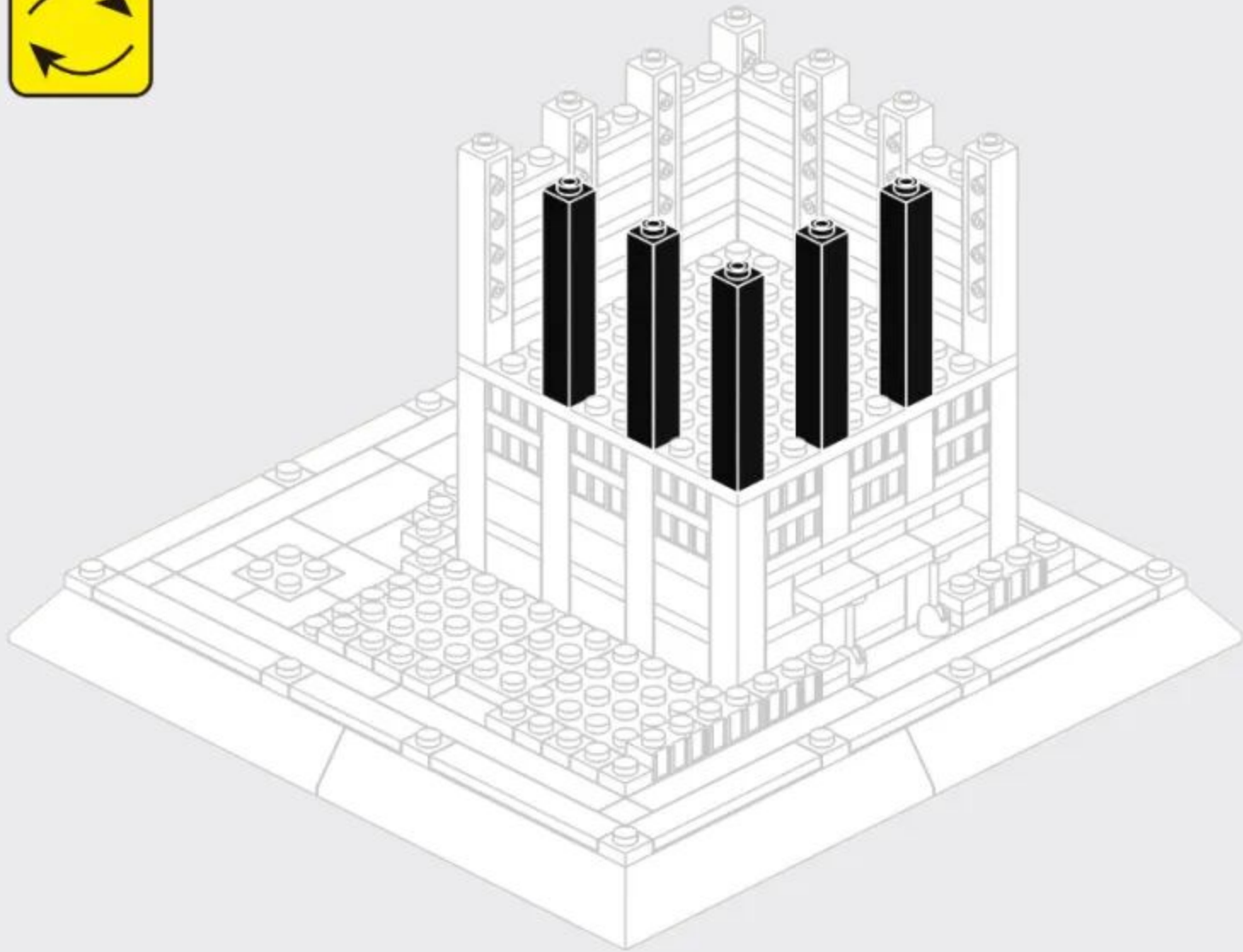

2-4

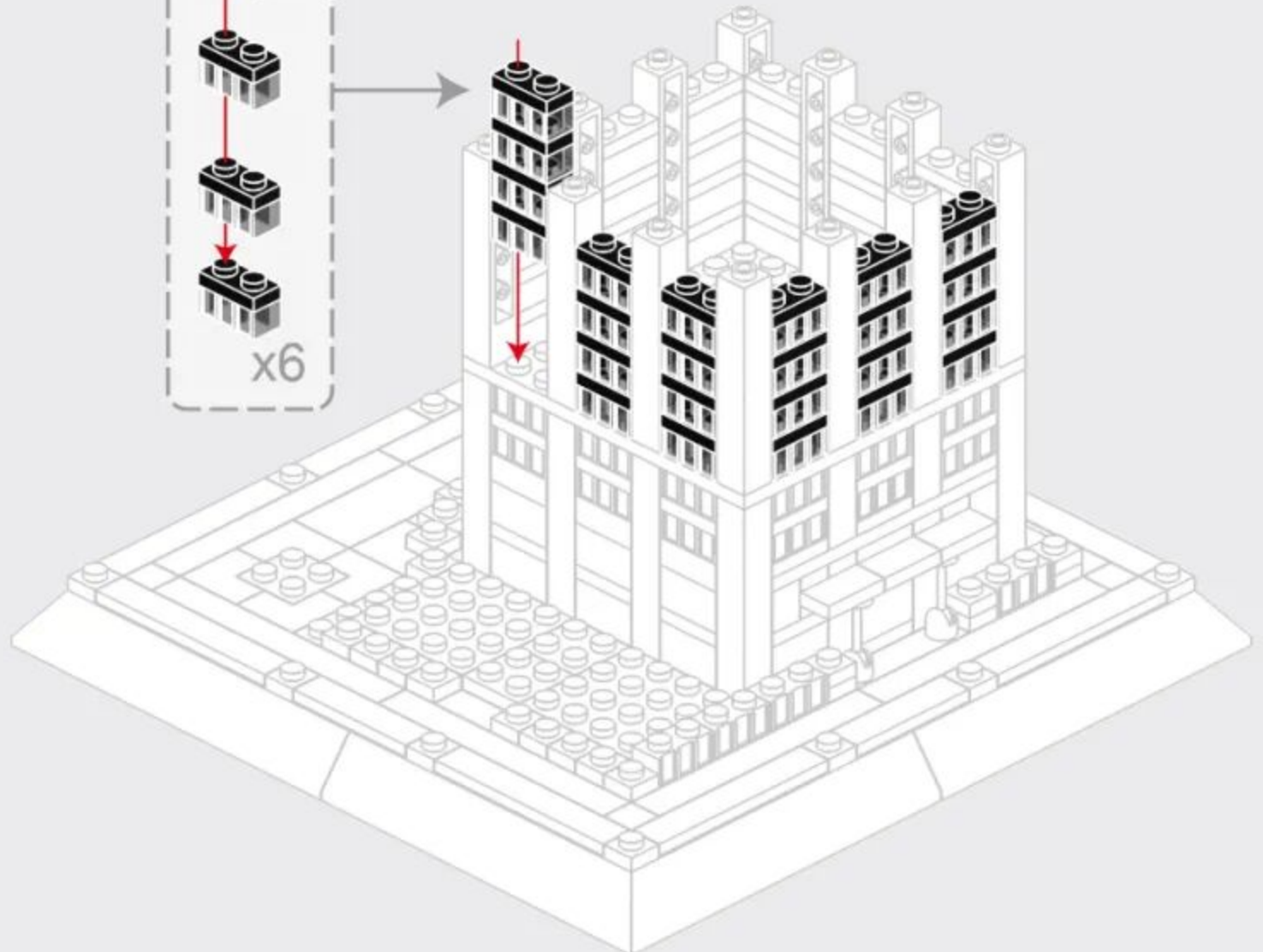
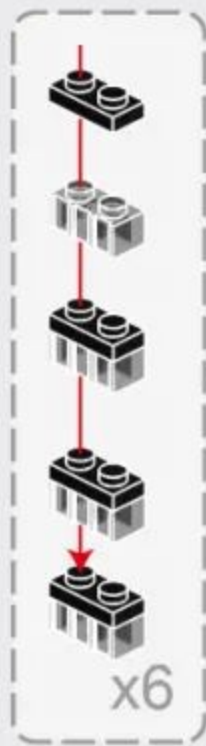

2-5

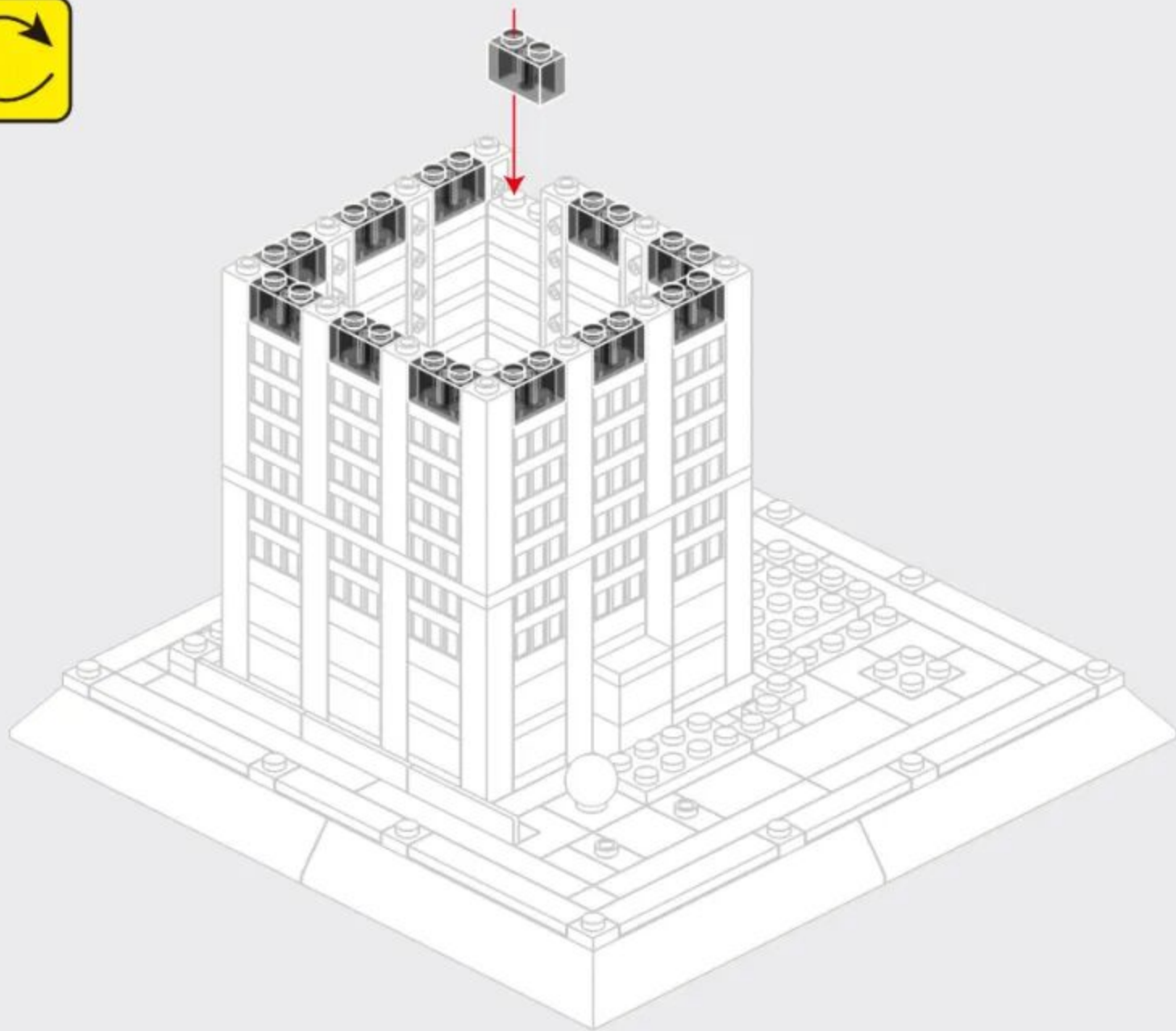

2-6

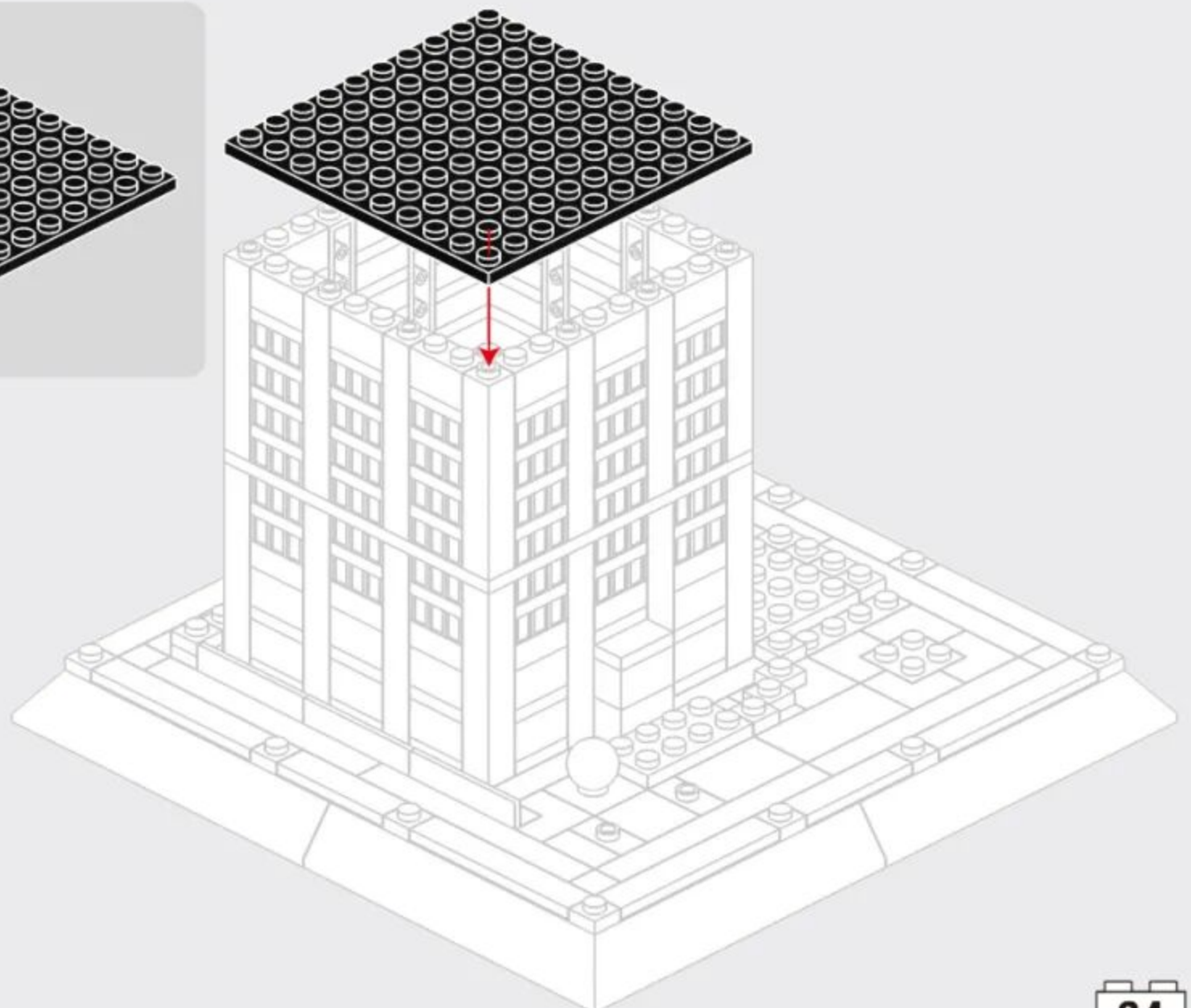
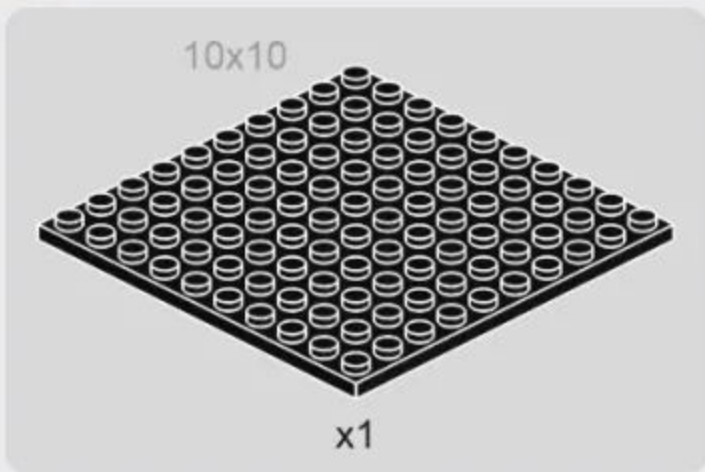

2-7

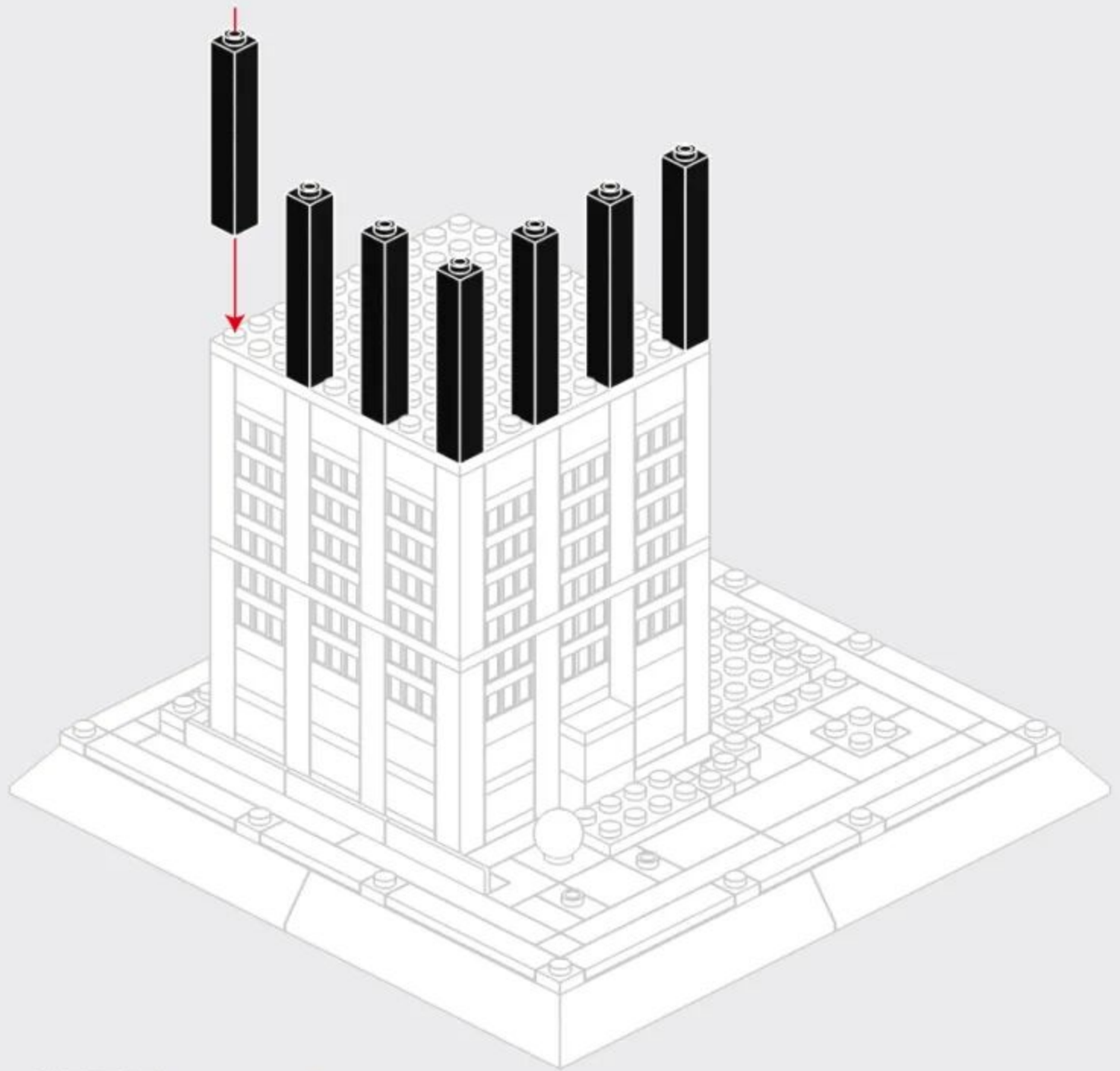

2-8

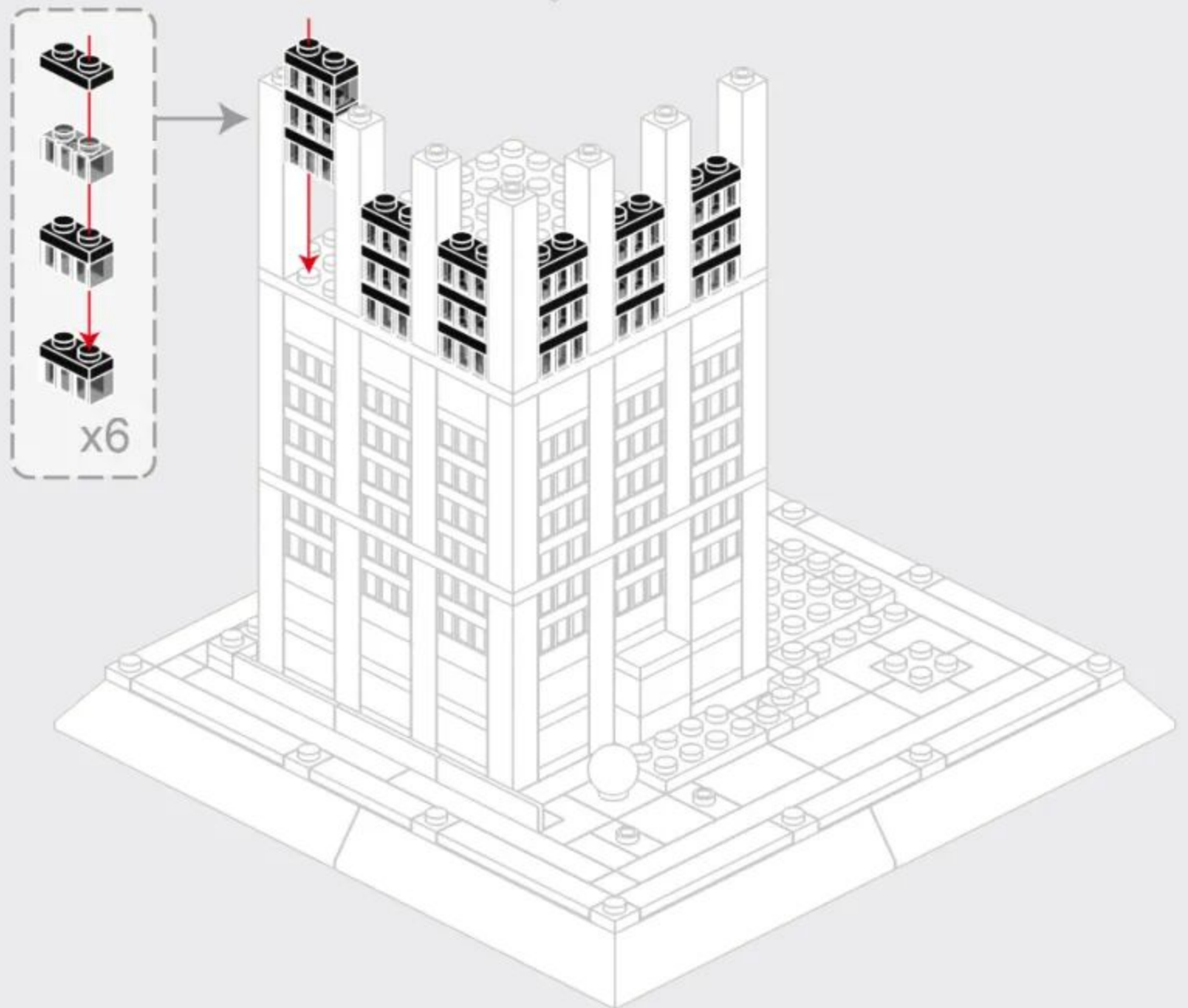

2-9

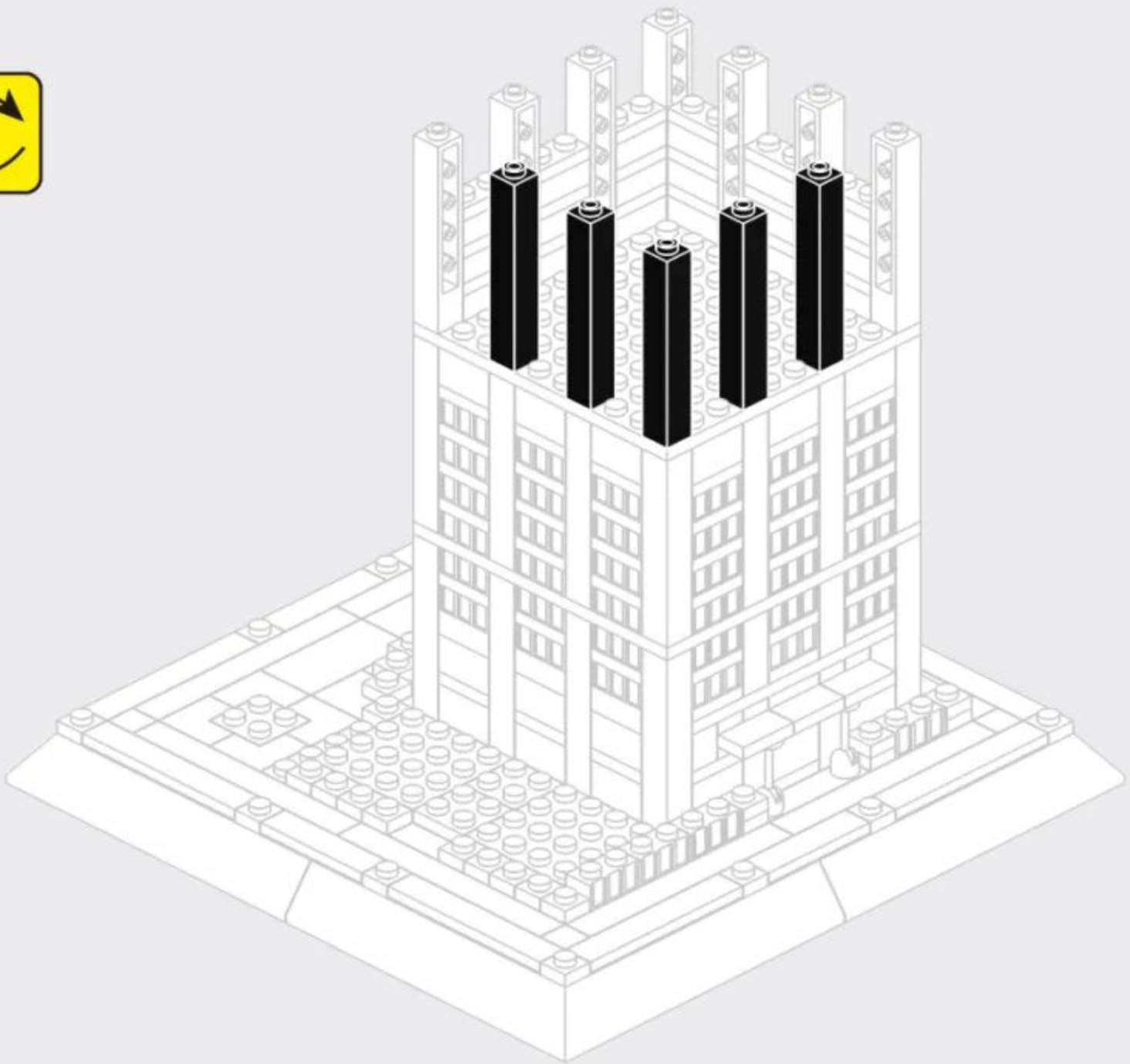

2-10

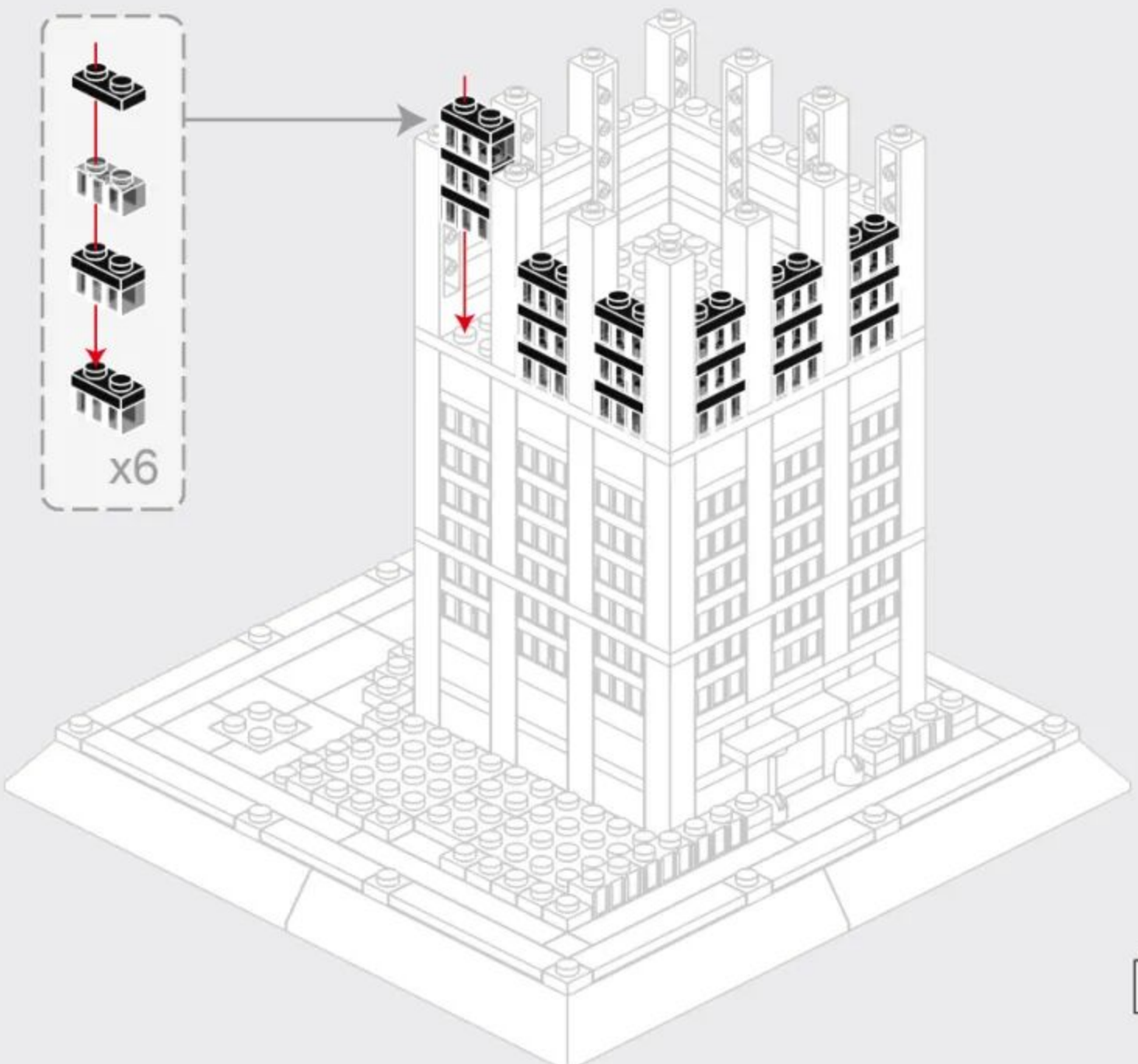
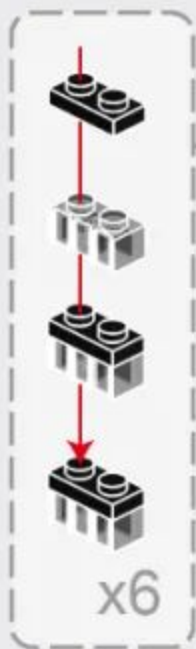

# 2-11

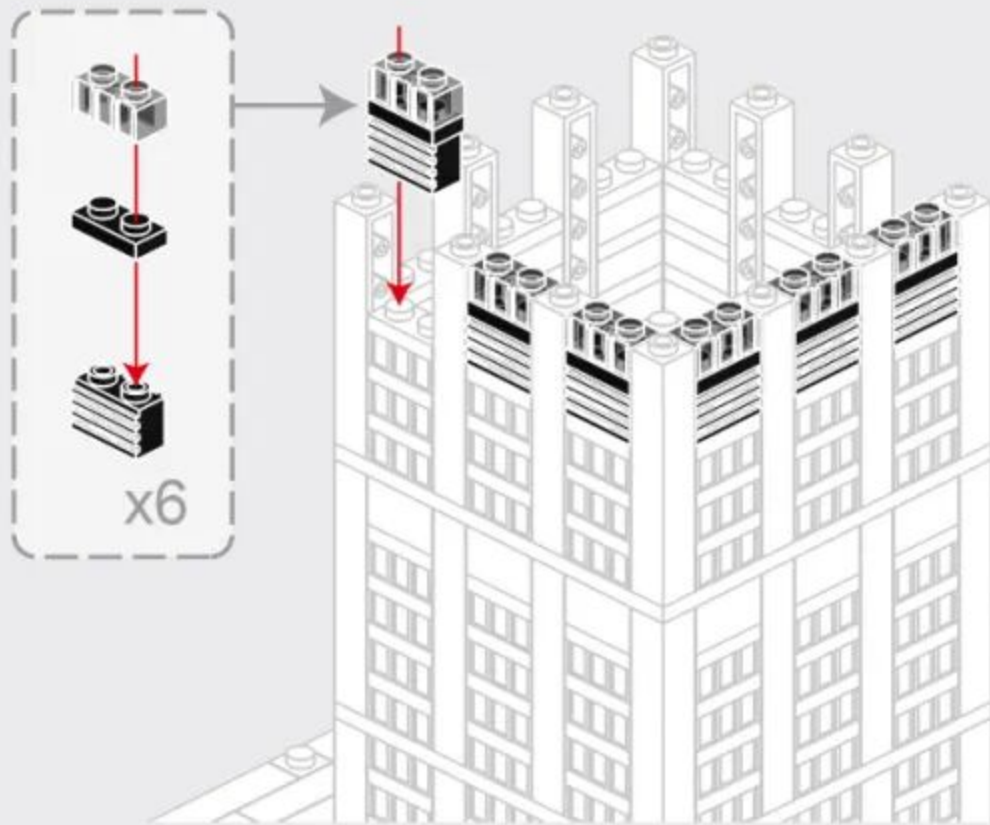

# 2-12

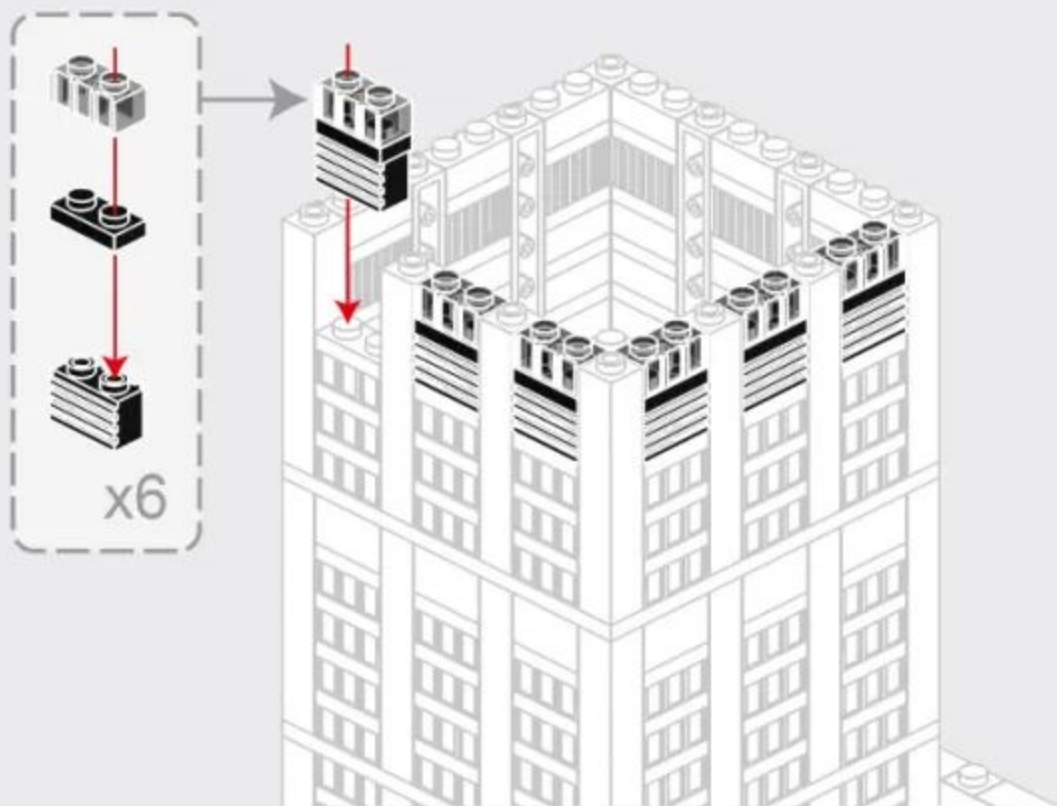

2-13

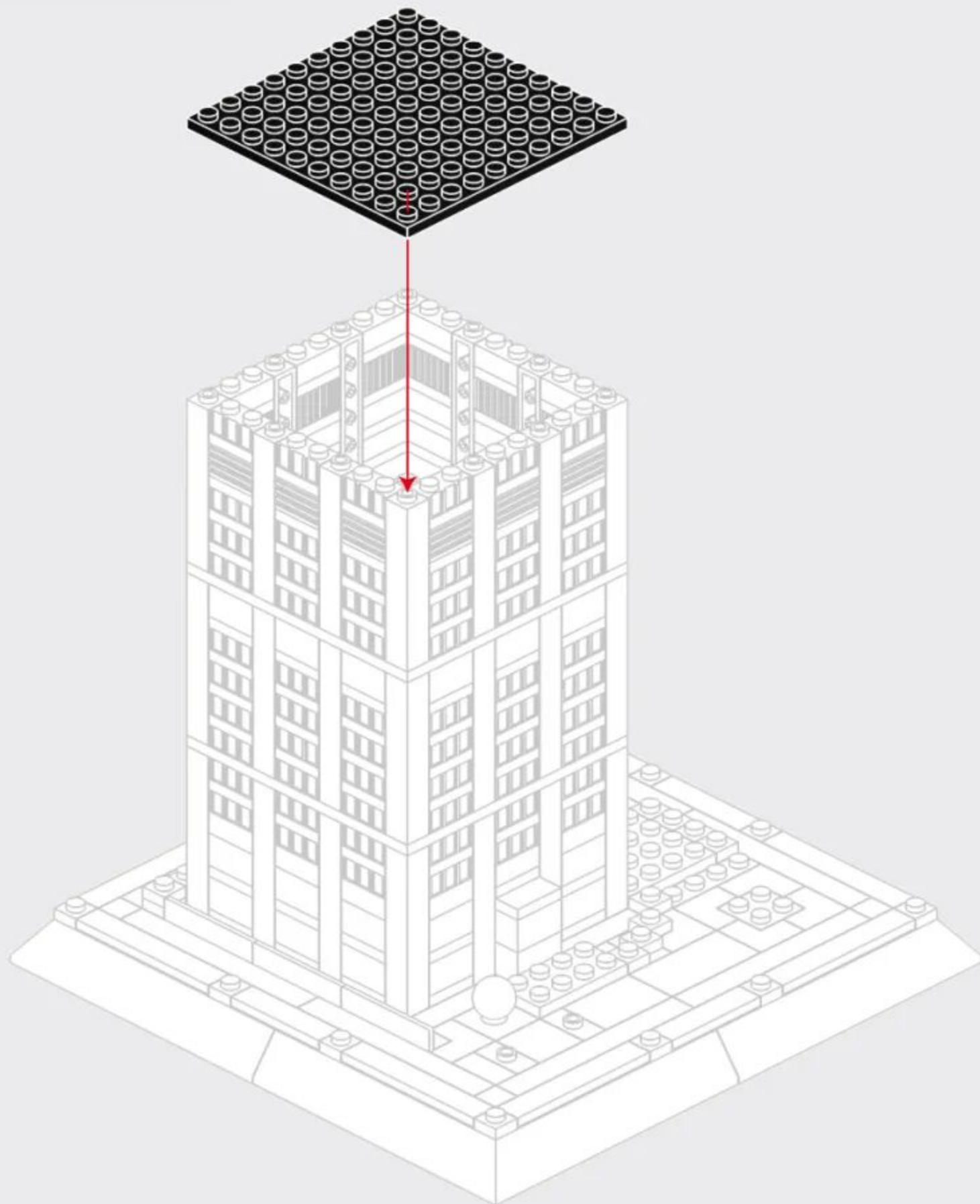
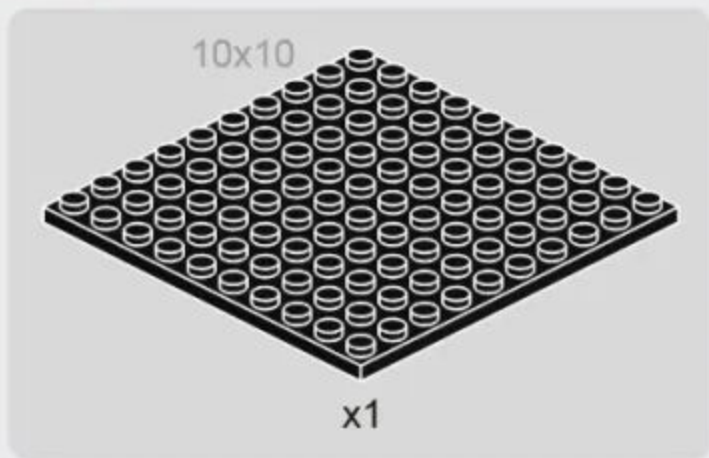



258PCS

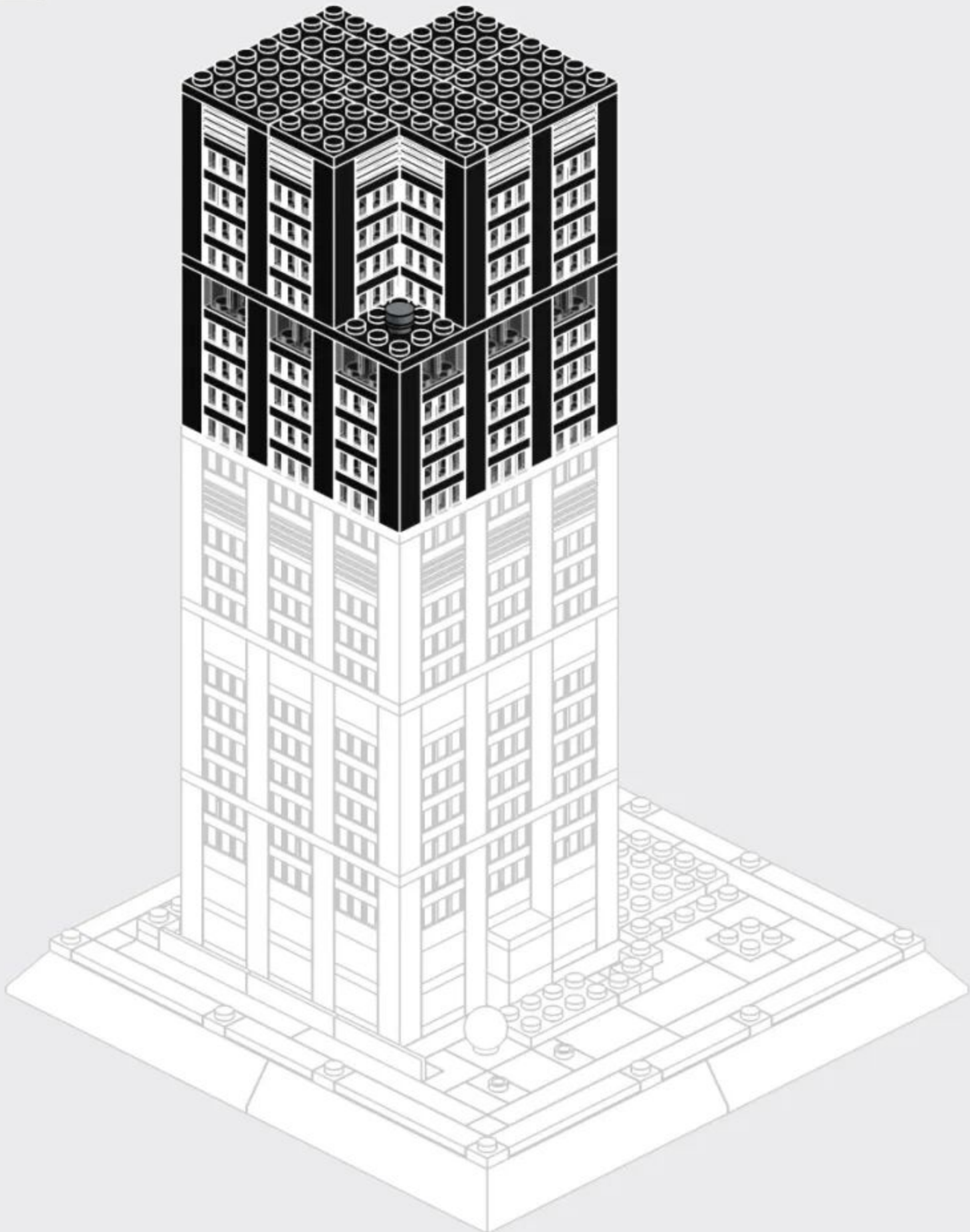

3-1

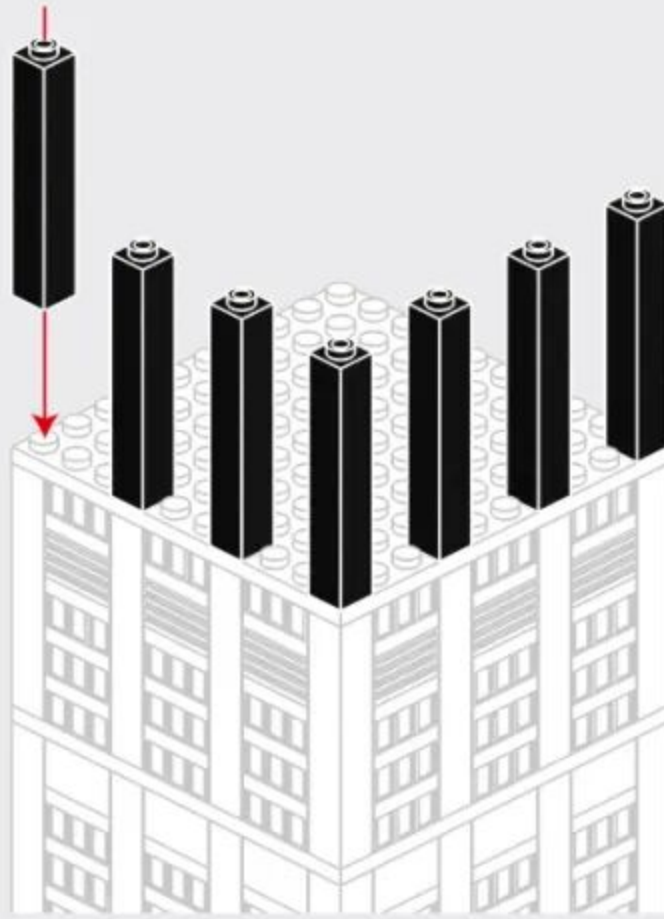

3-2

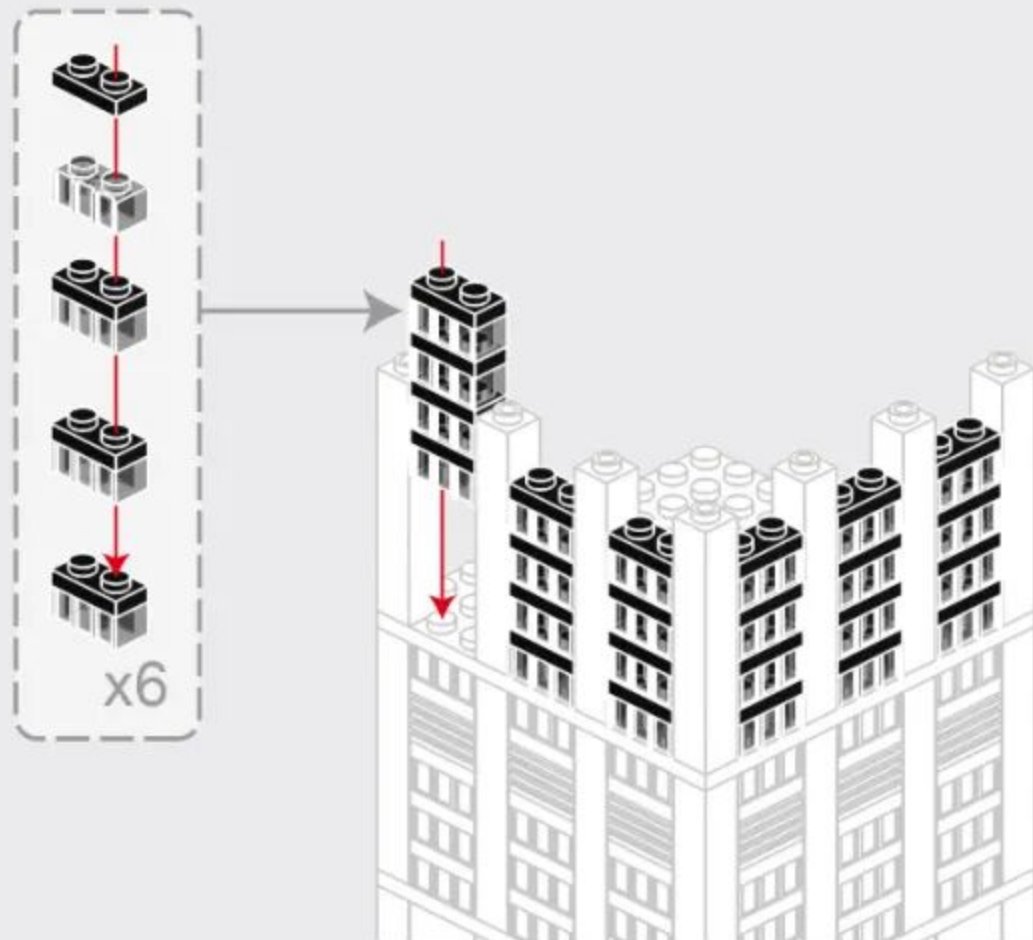

3-3

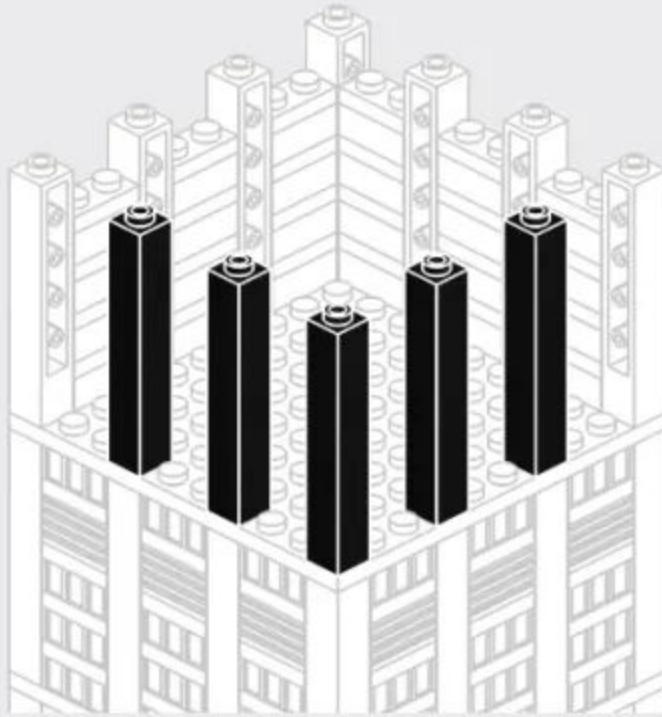

3-4

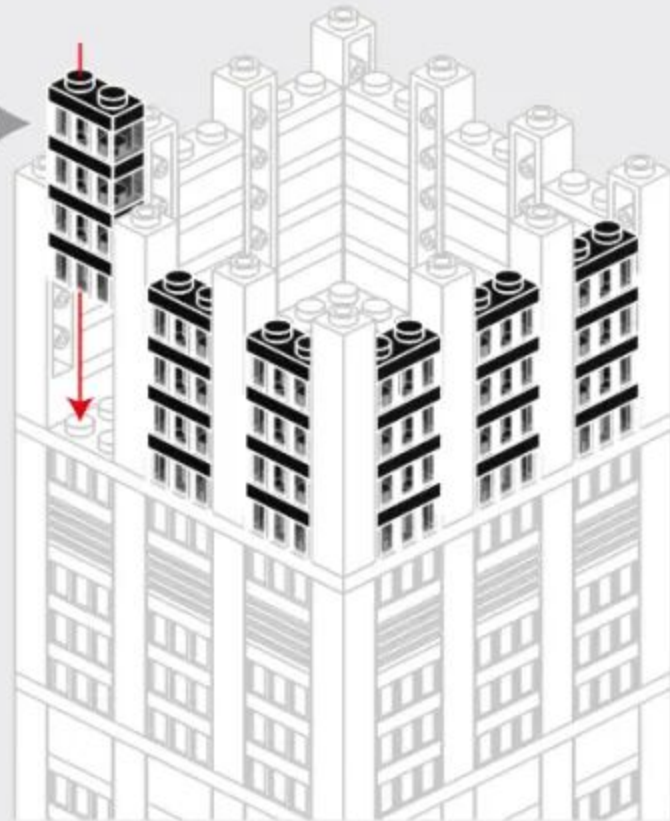
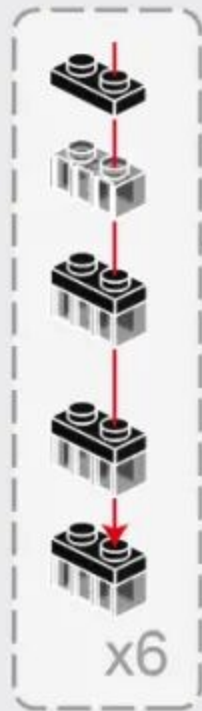

3-5

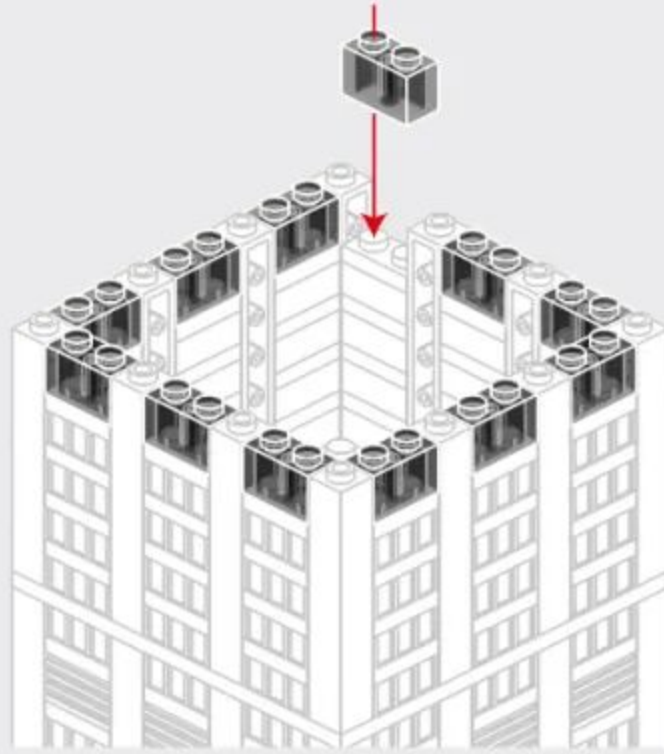

3-6

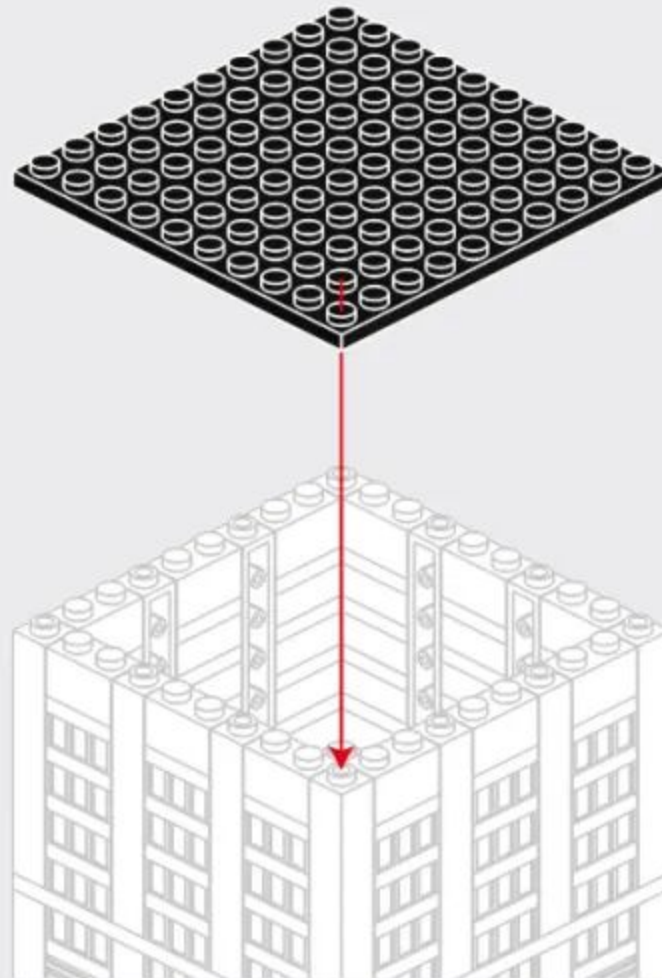
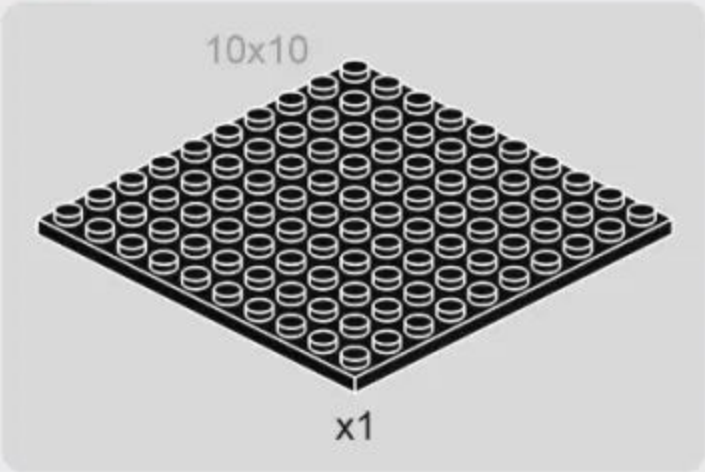

3-7

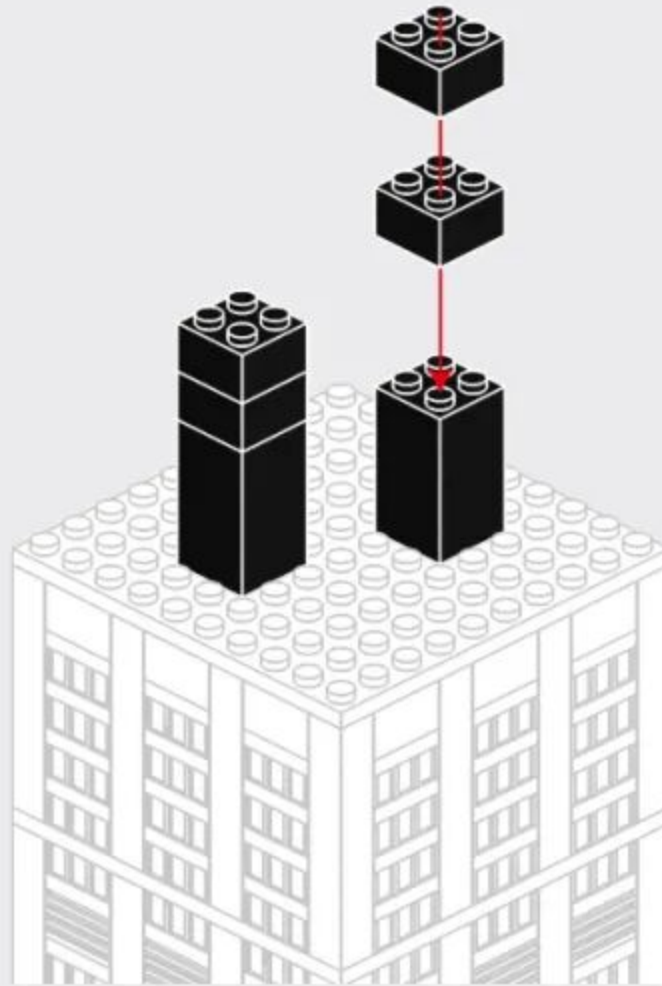
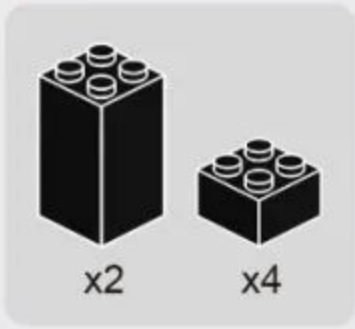

3-8

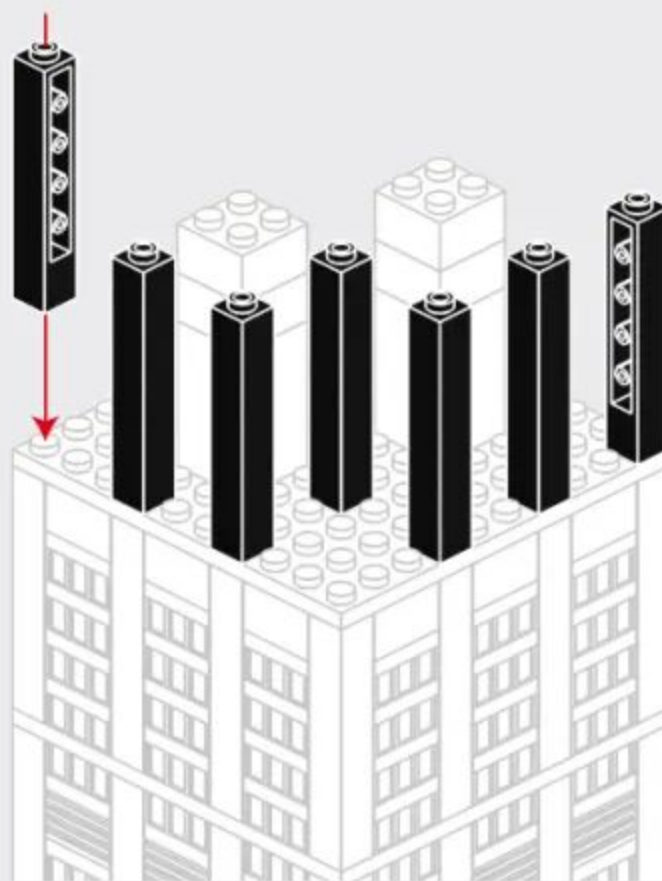

3-9

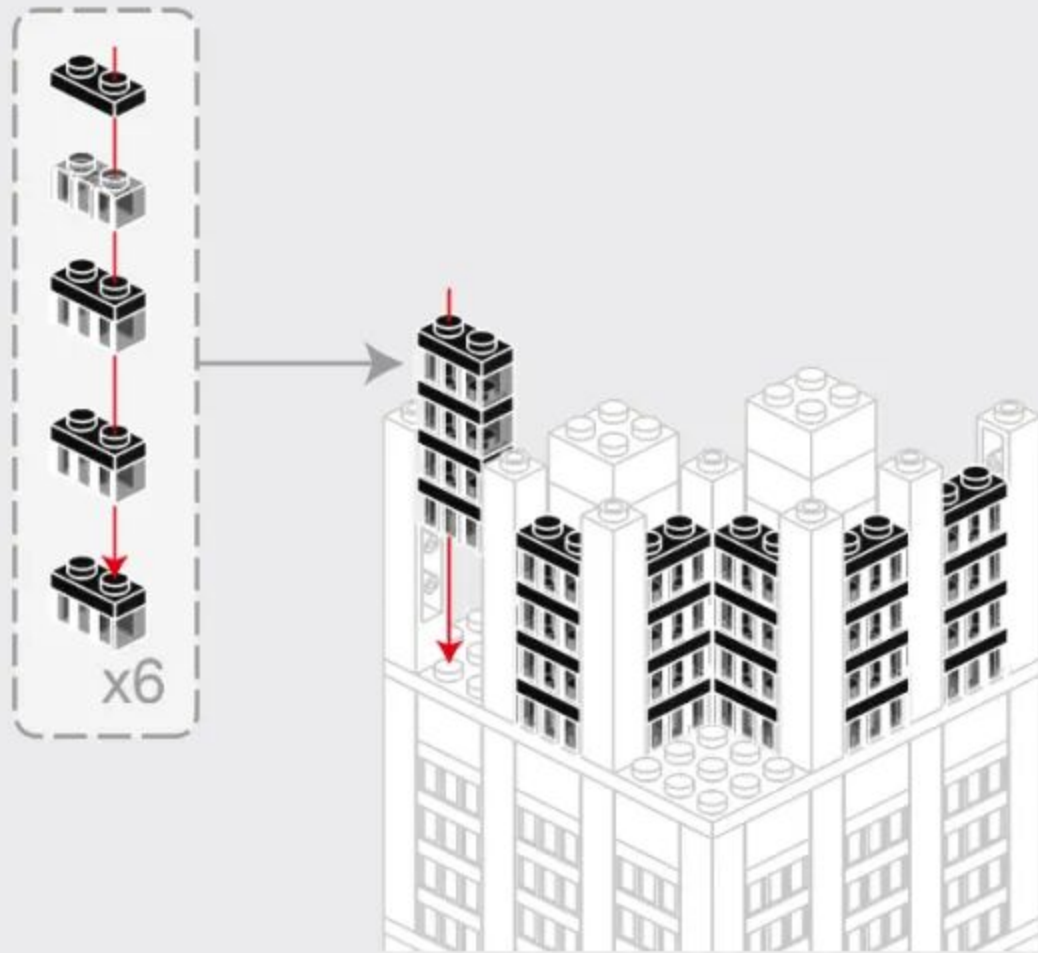

3-10

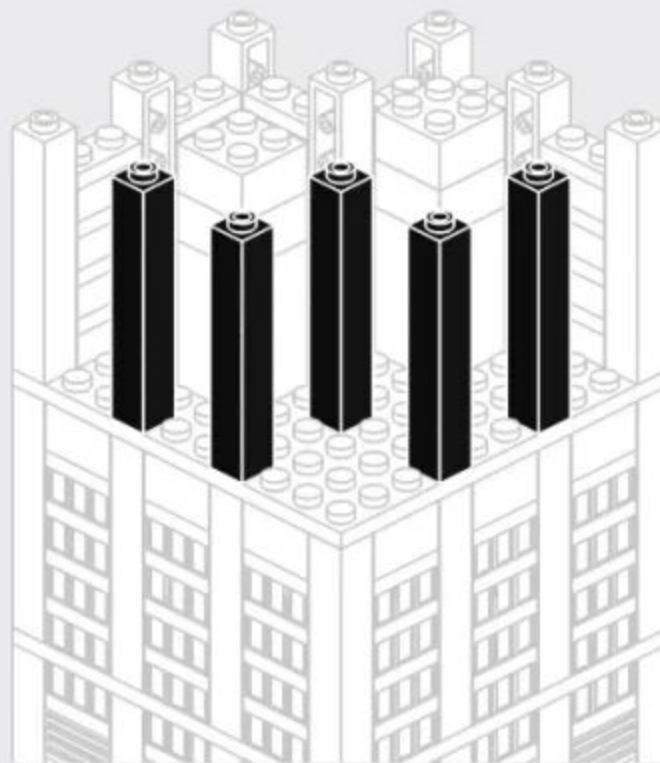
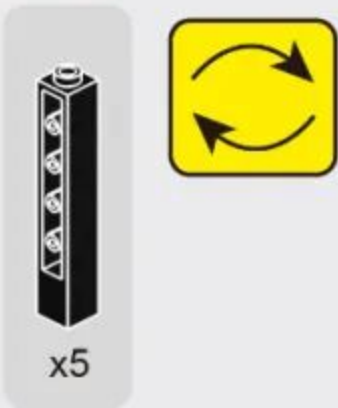

### 3-11

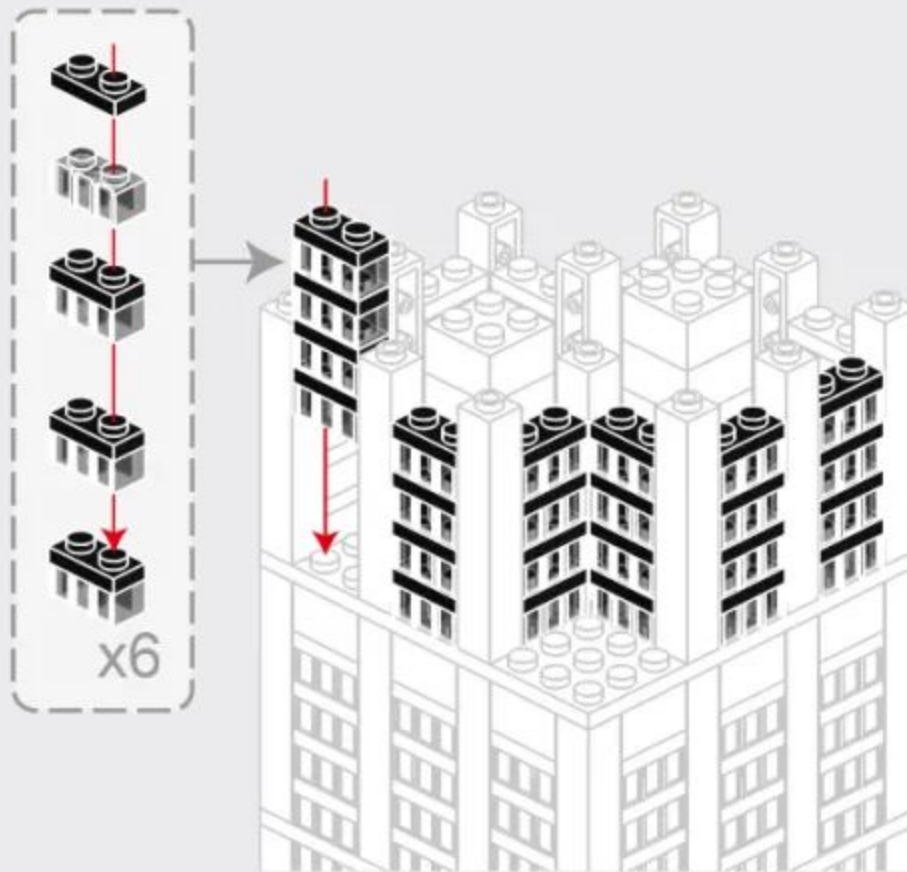

### 3-12

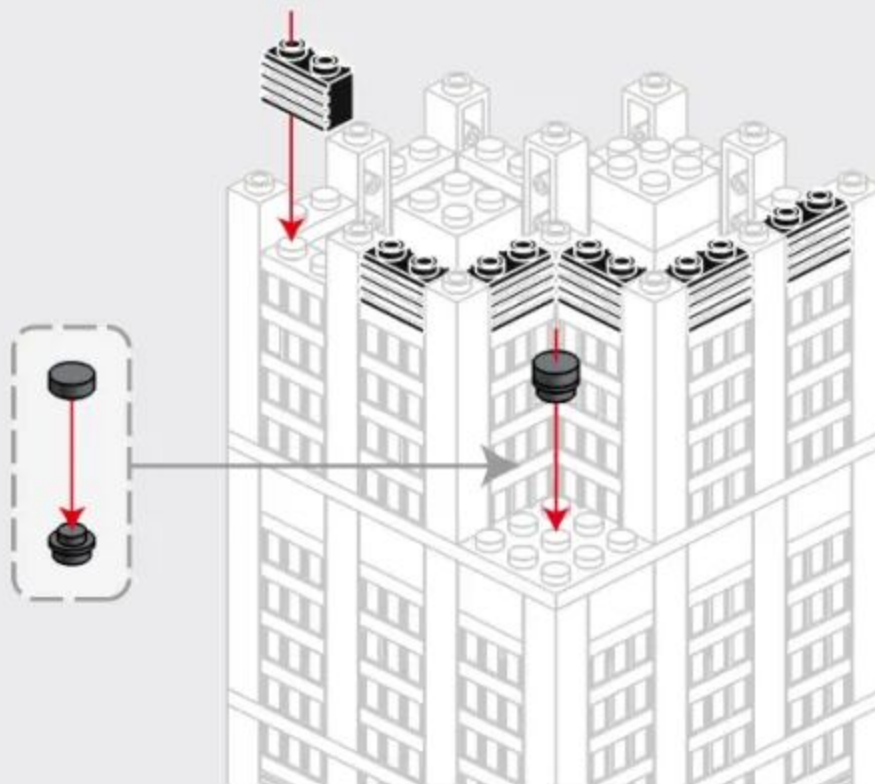

### 3-13

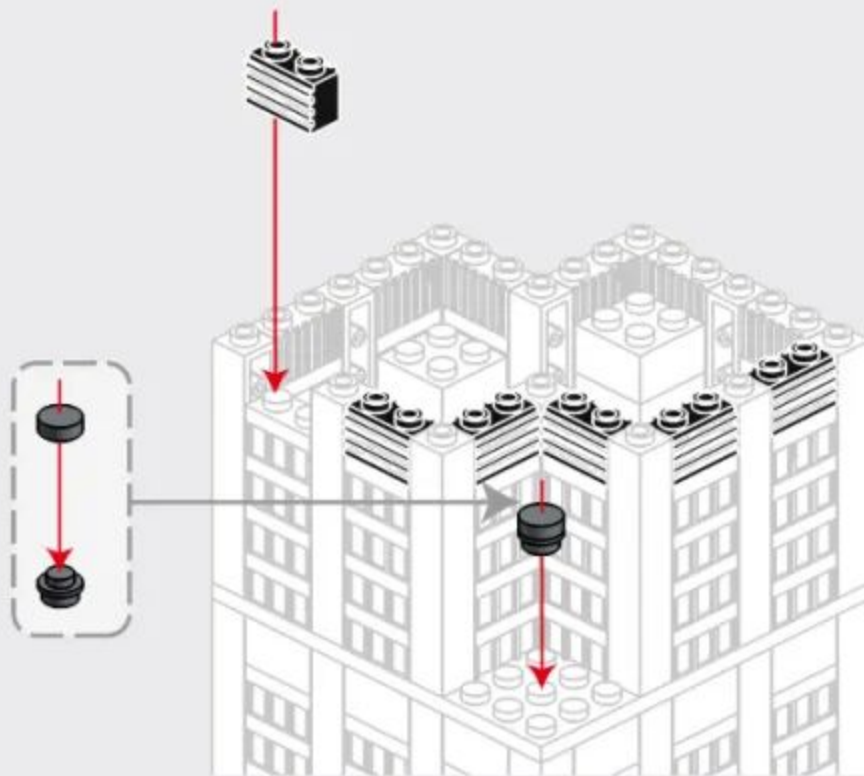

### 3-14

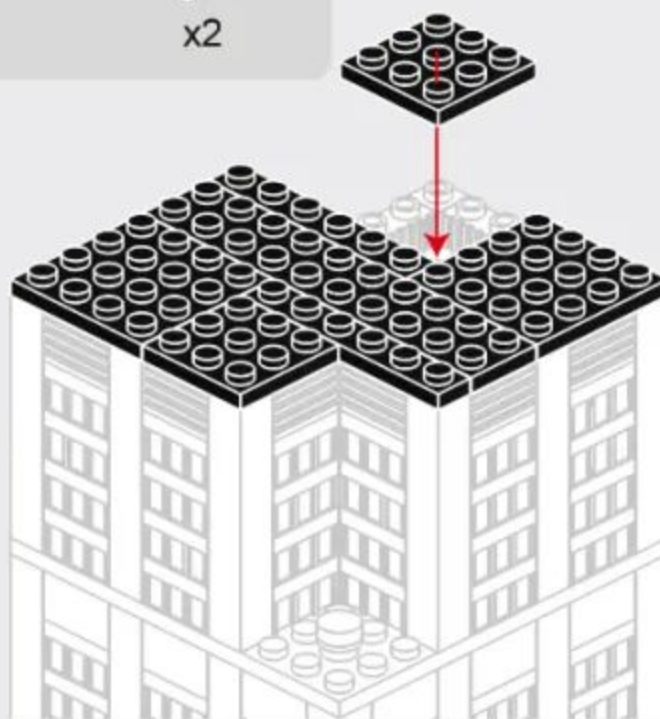
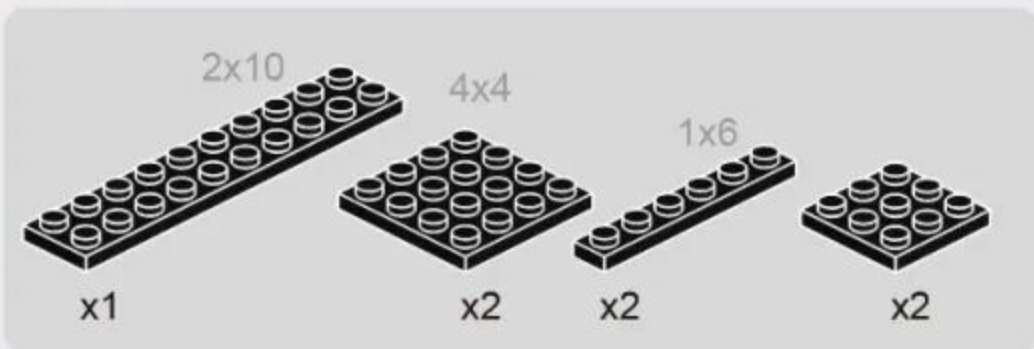



261 PCS

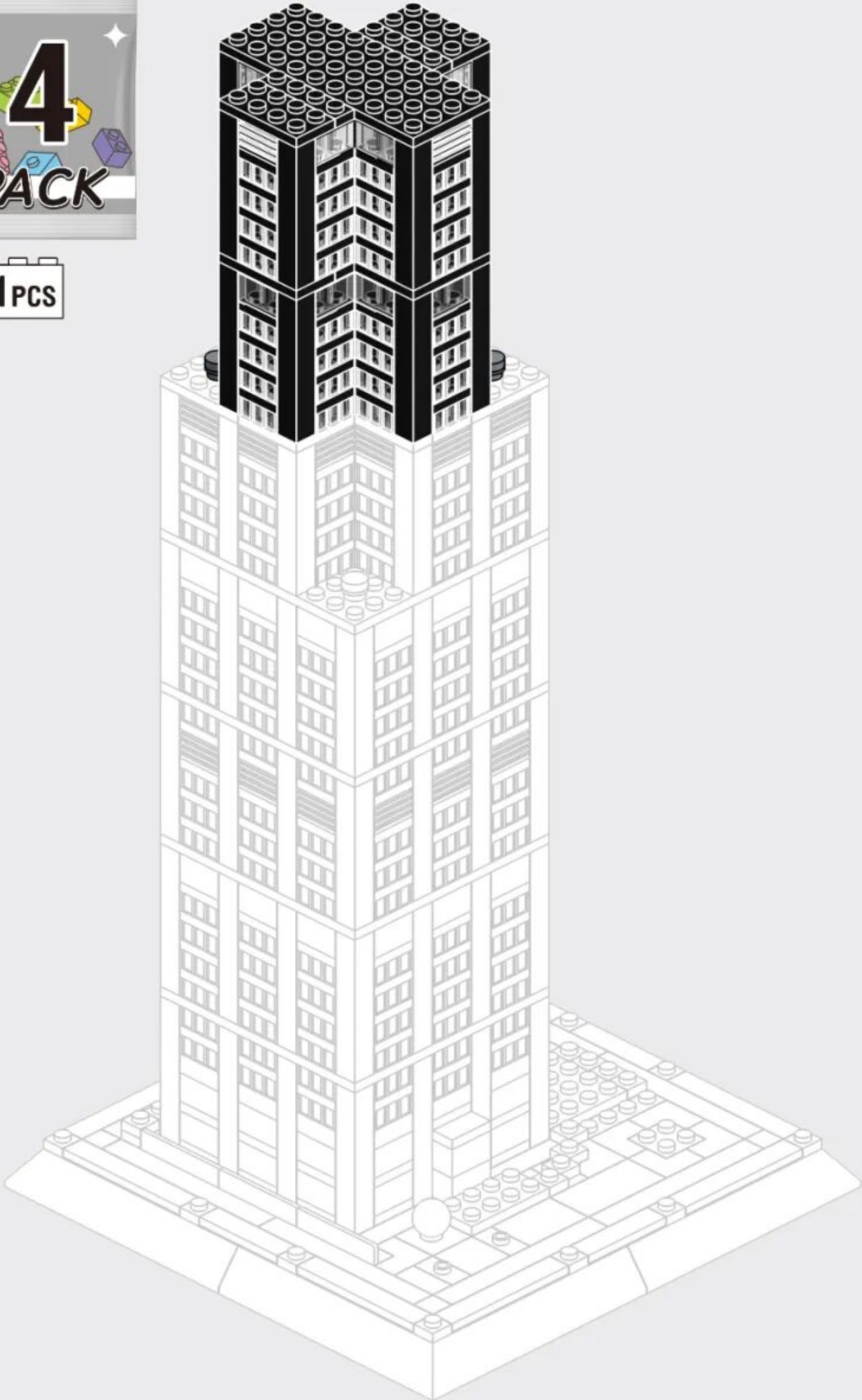

# 4-1

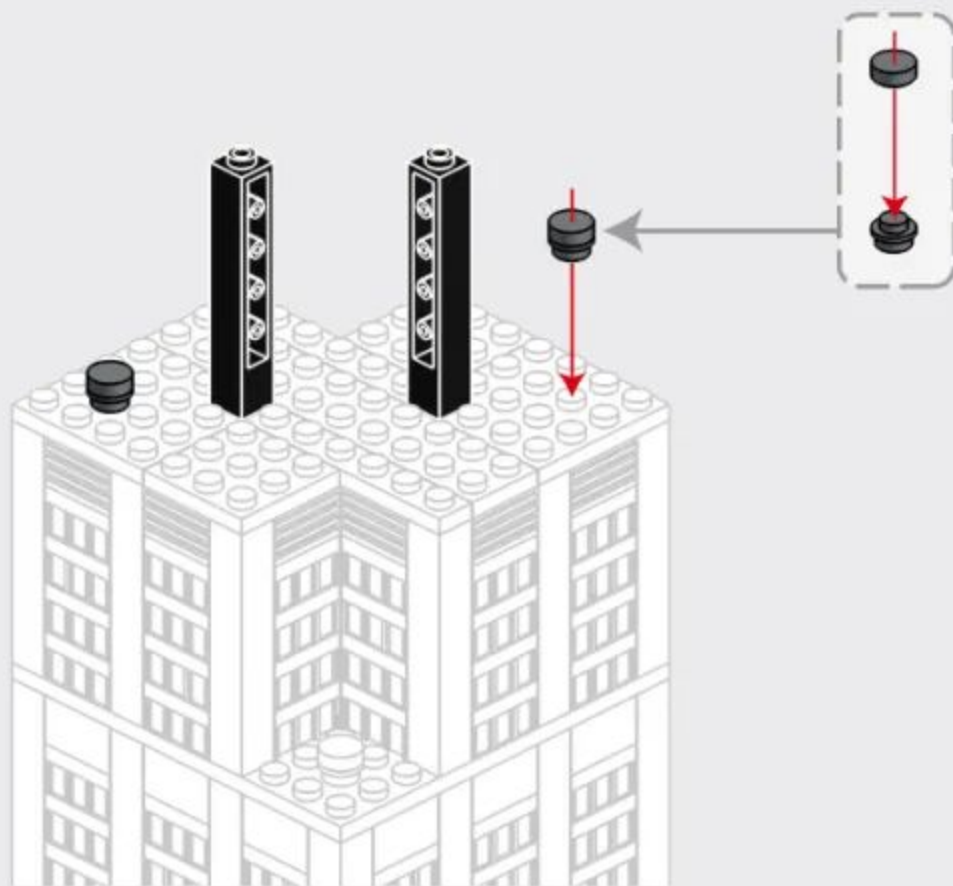
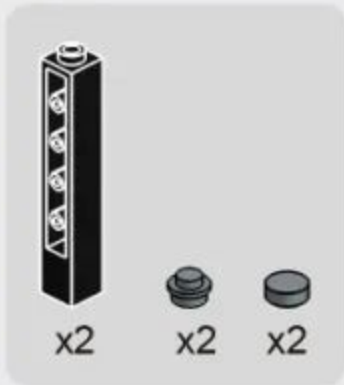

# 4-2

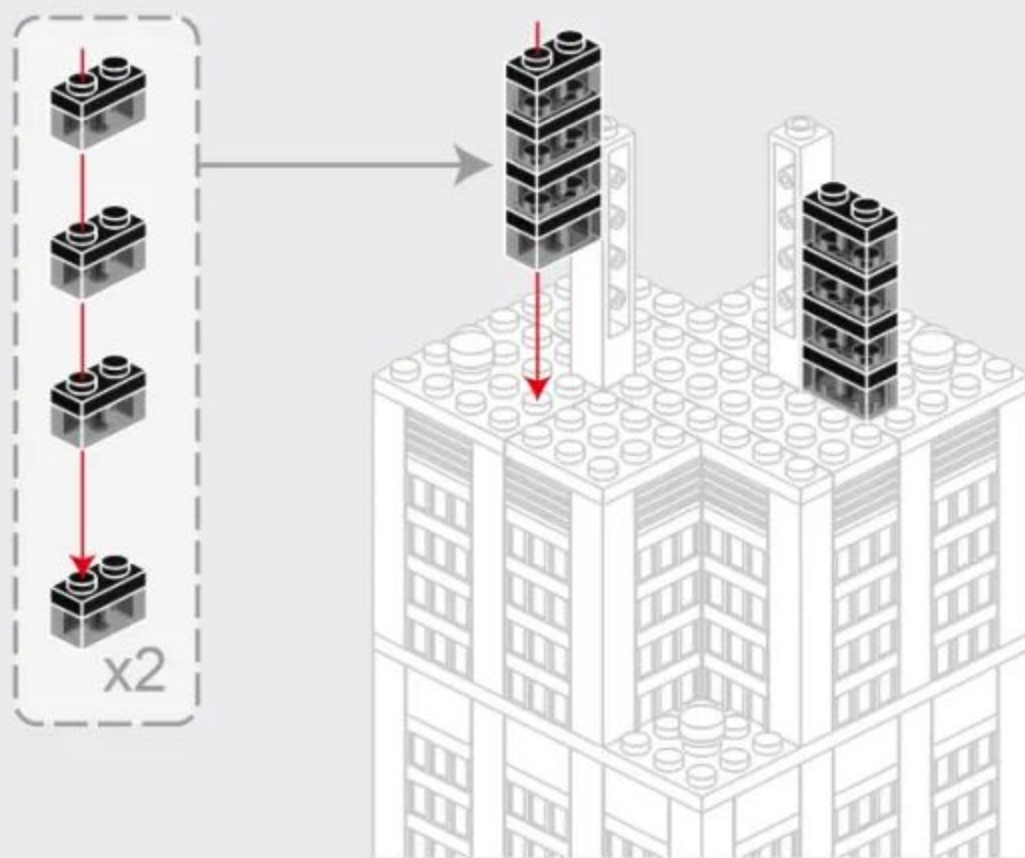

4-3

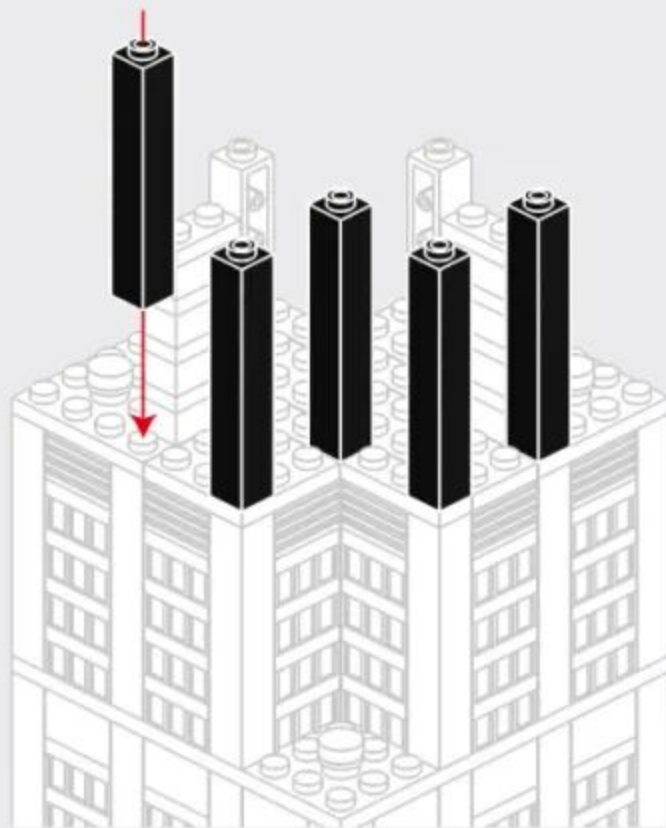

4-4

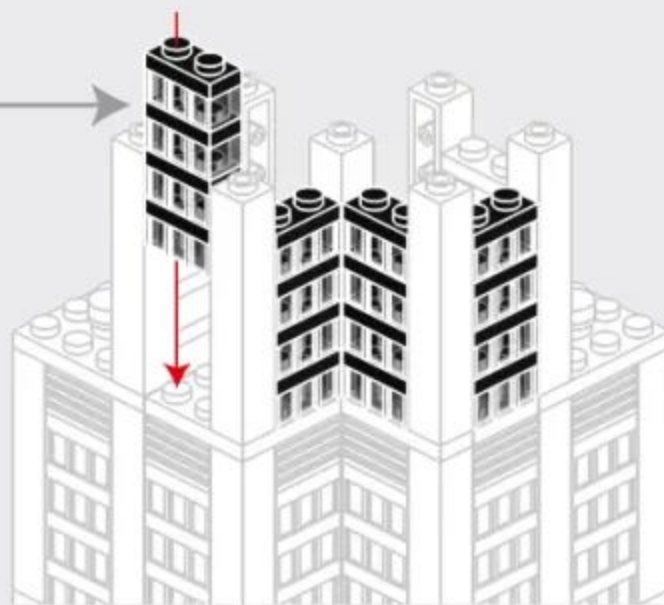
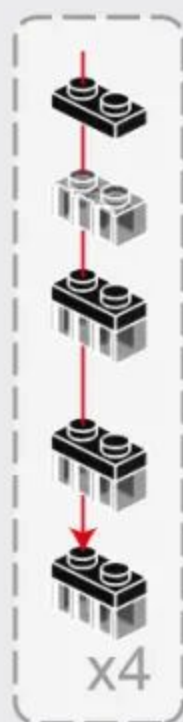

4-5

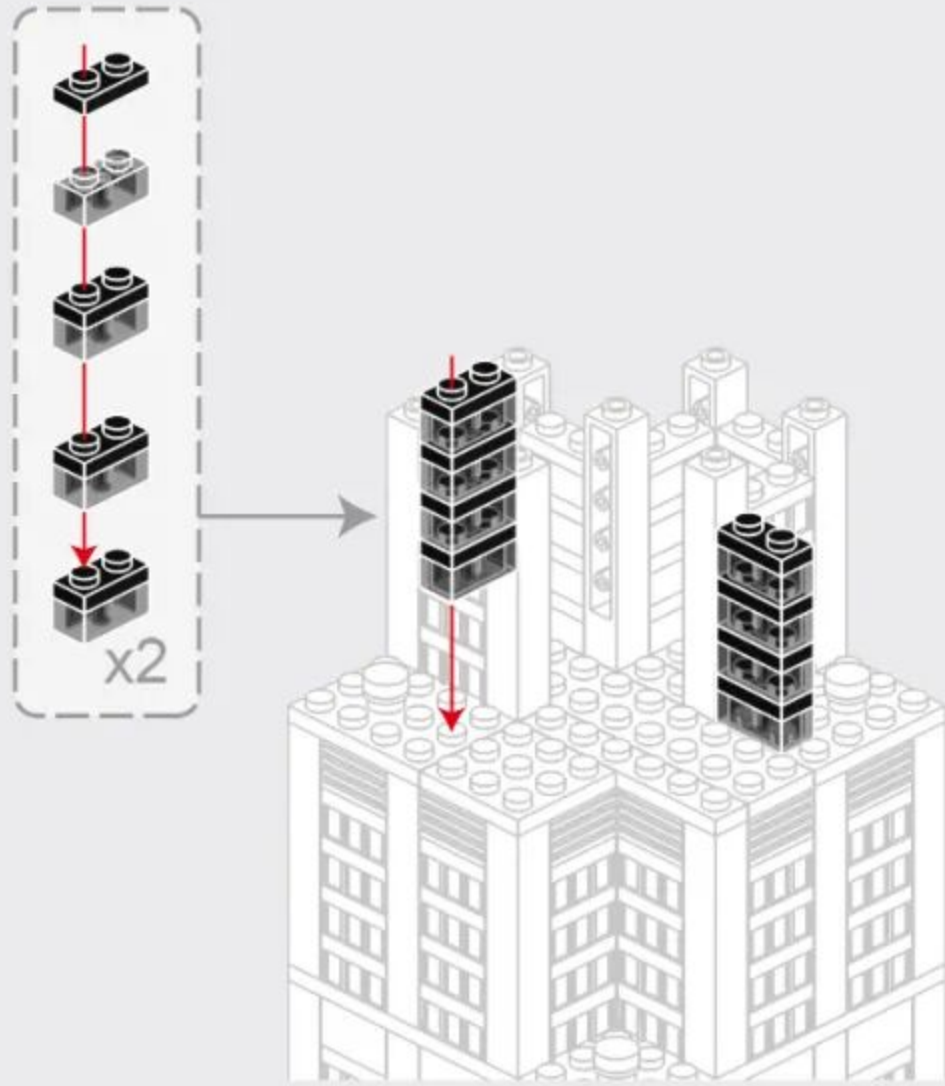

4-6

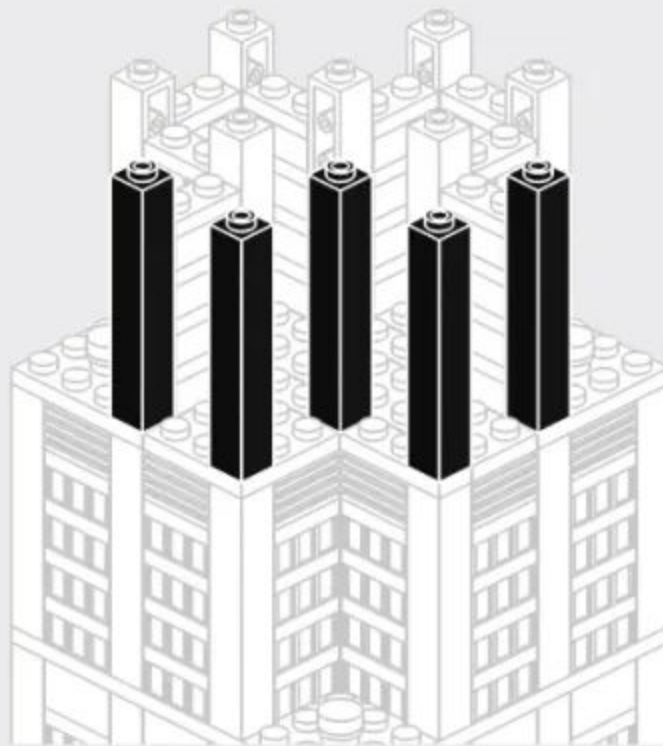

4-7

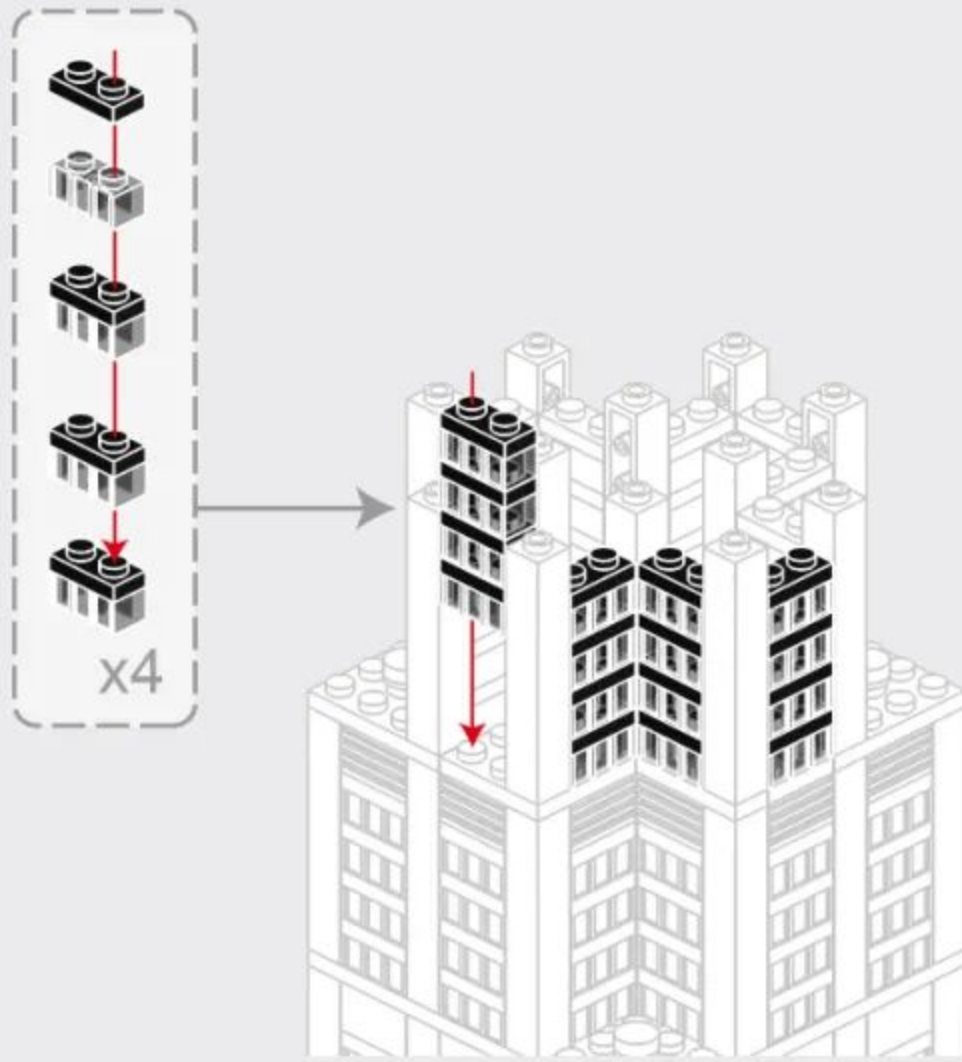

4-8

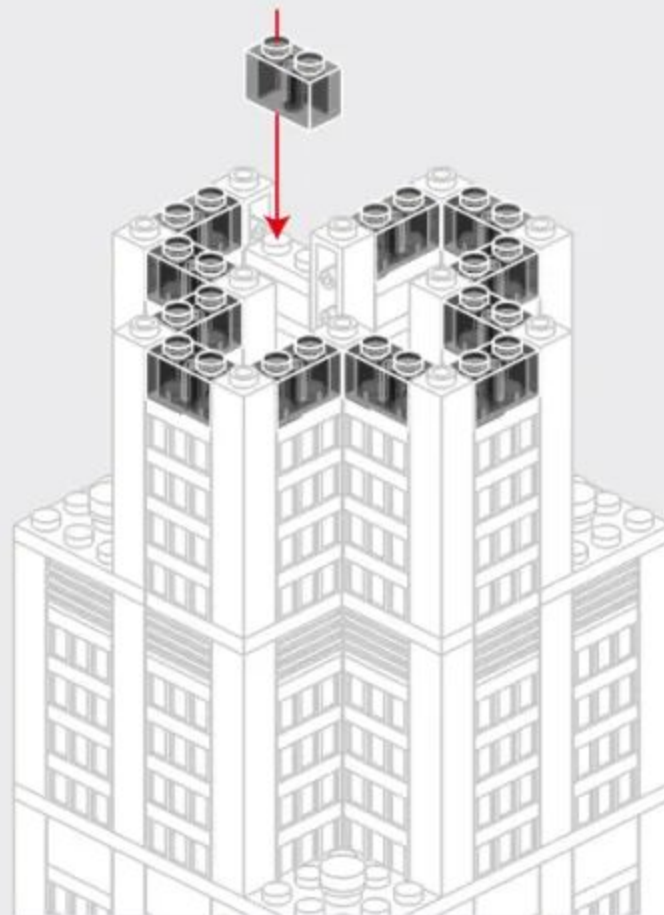

# 4-9

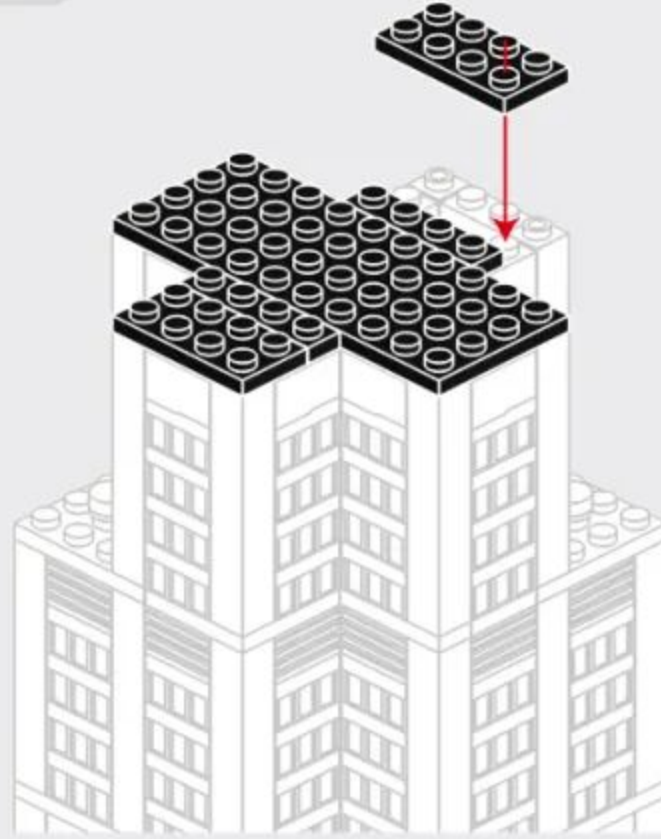
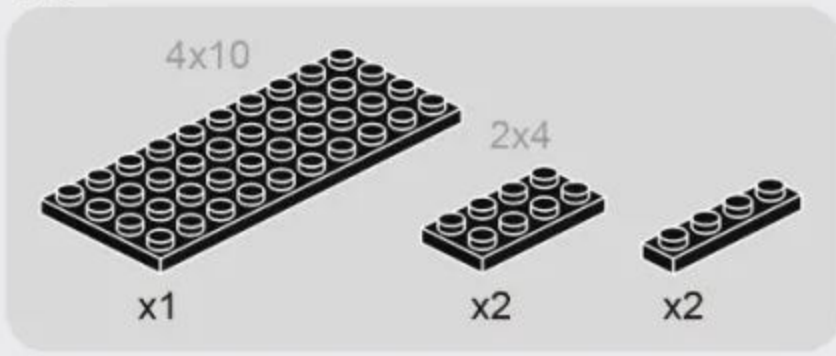

# 4-10

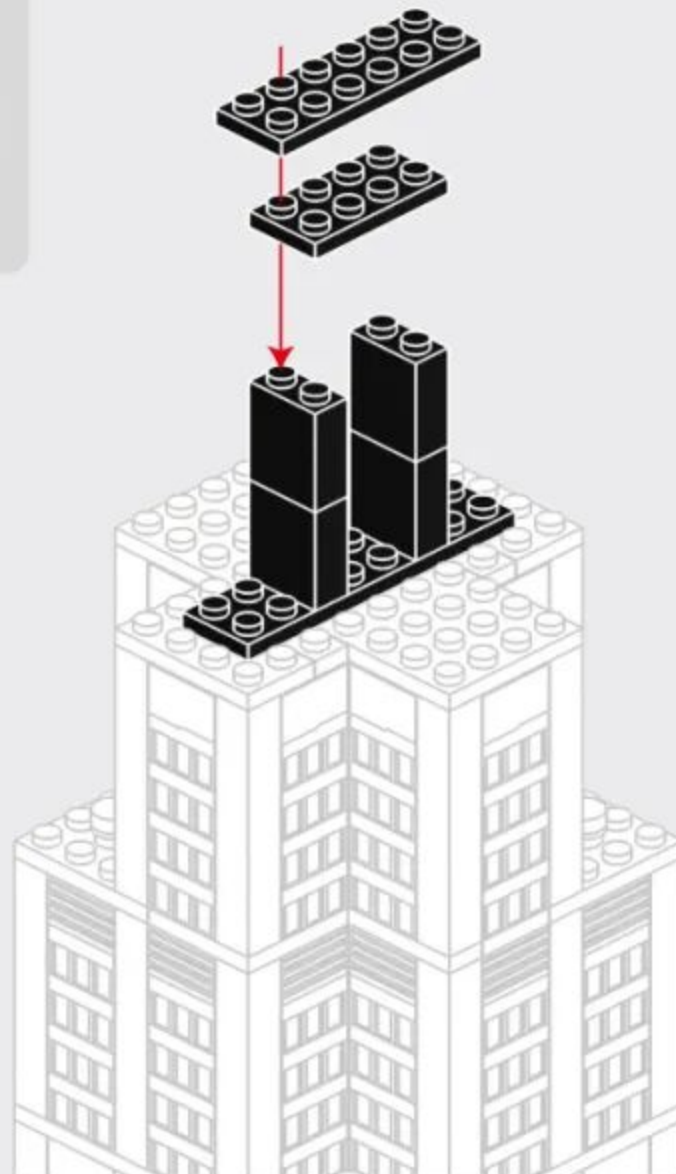
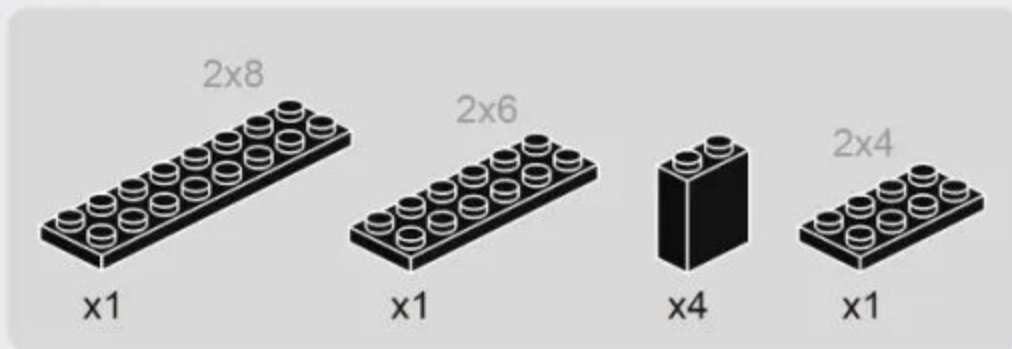

# 4-11

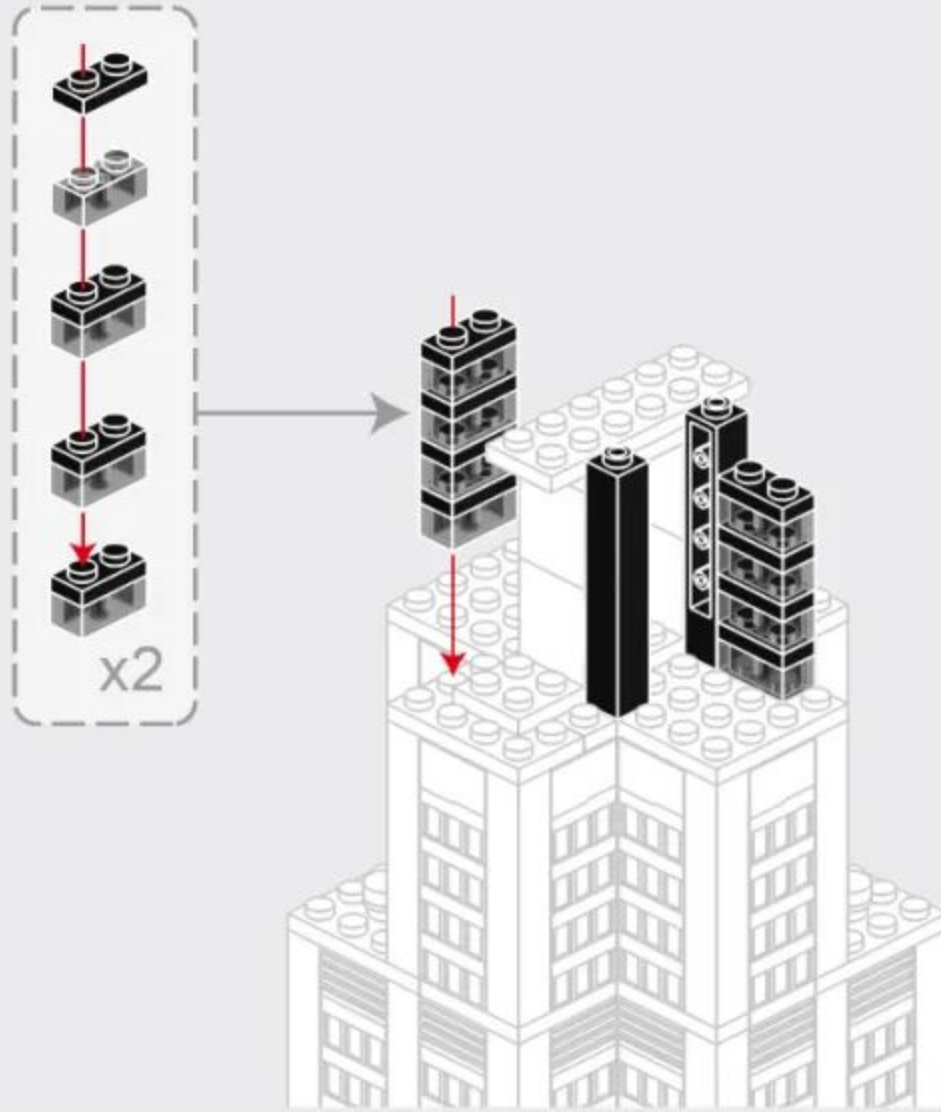
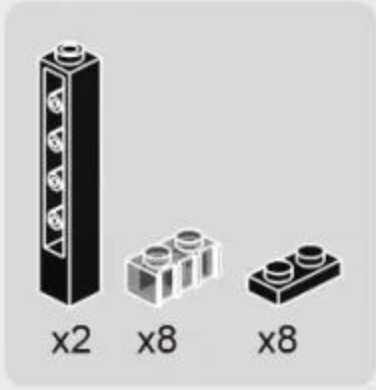

# 4-12

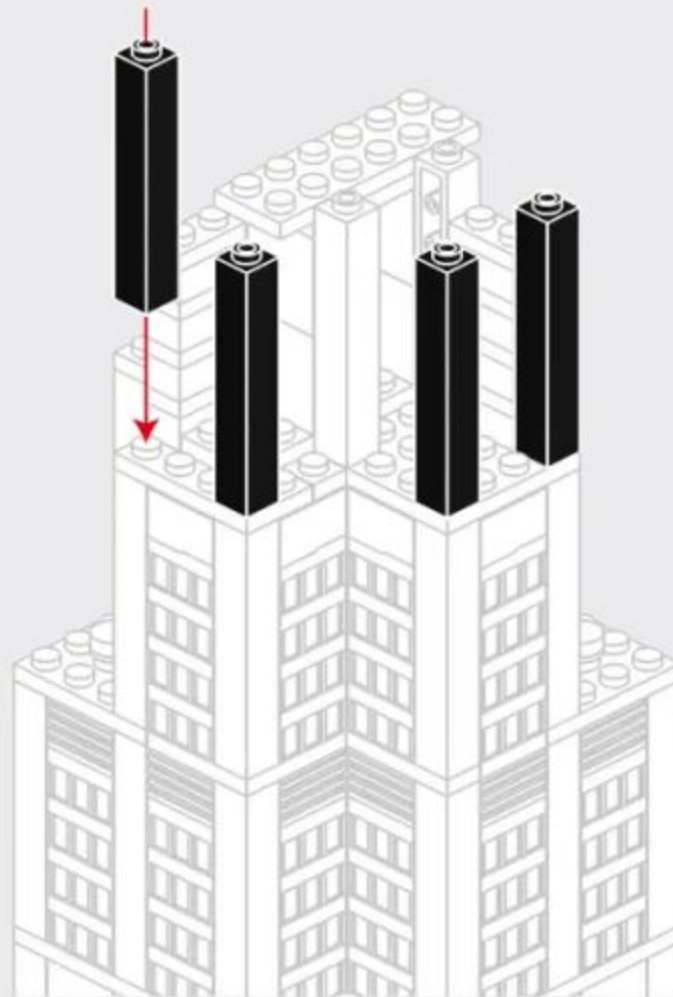

# 4-13

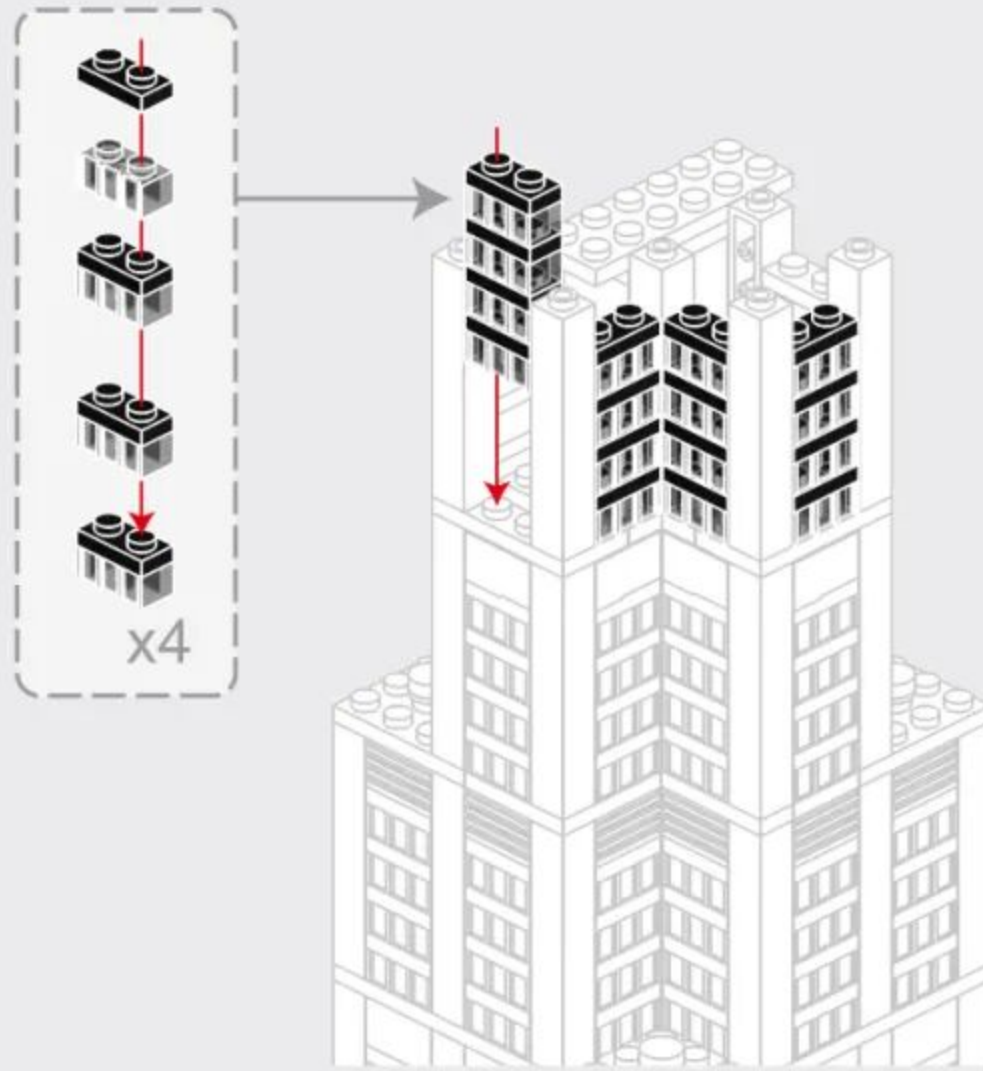

# 4-14

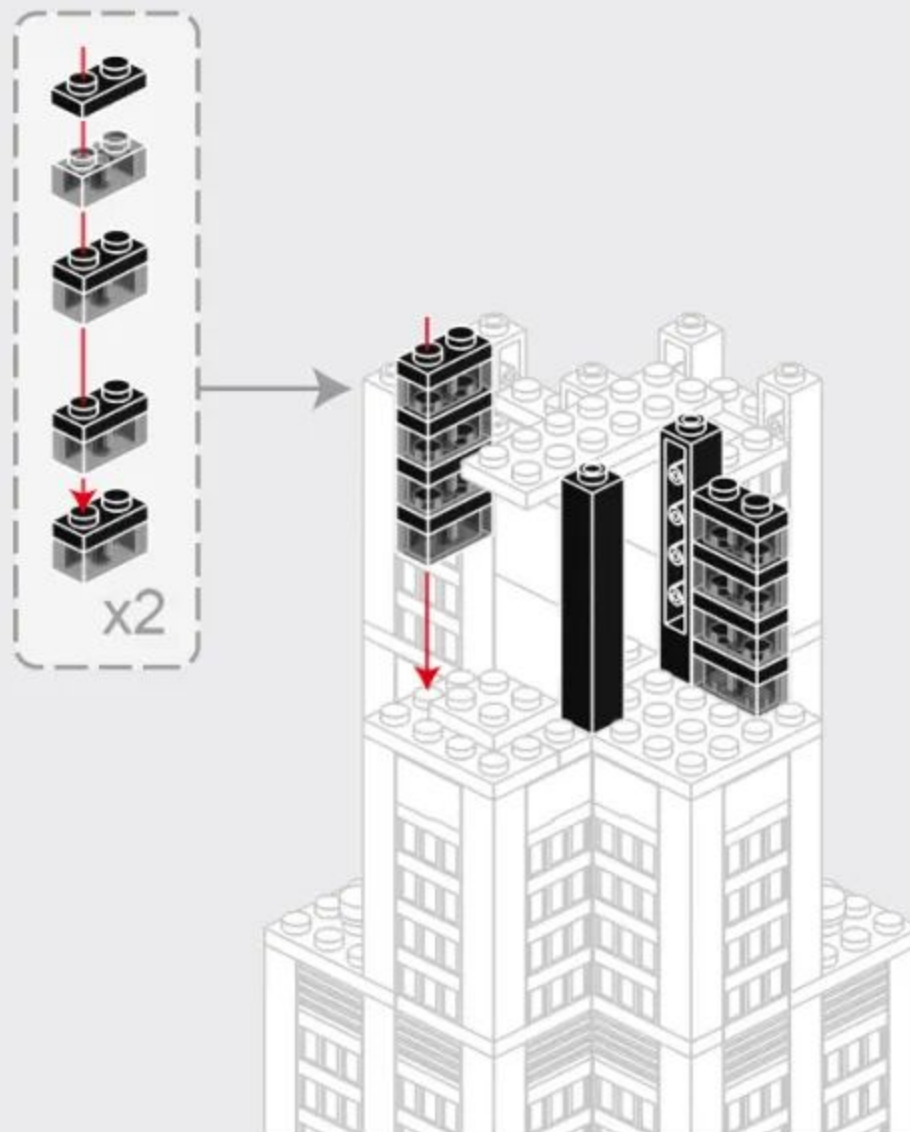
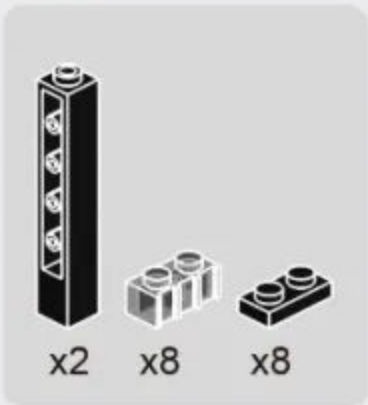

4-15

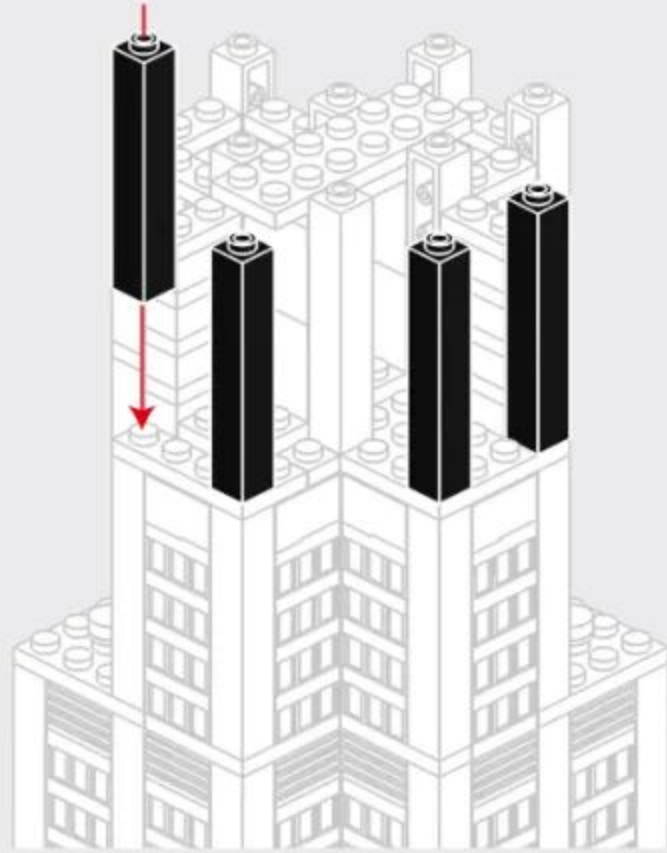

4-16

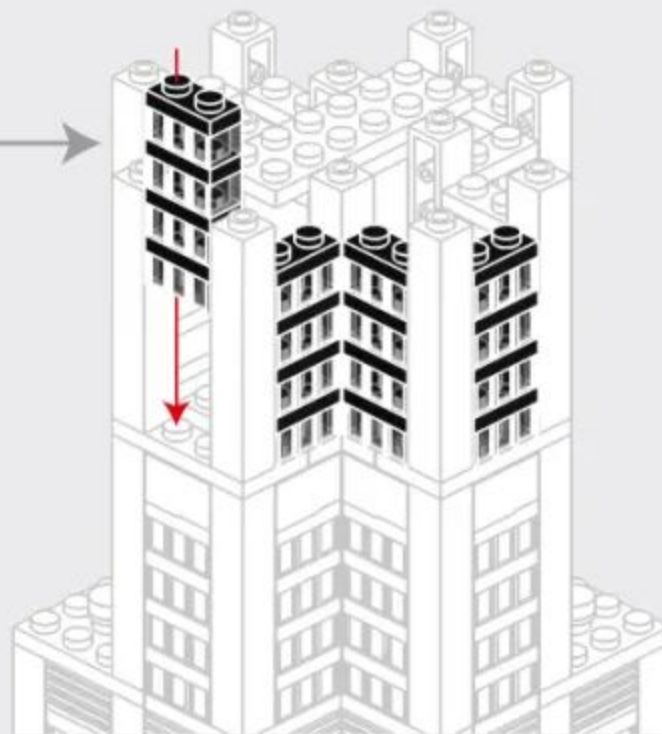
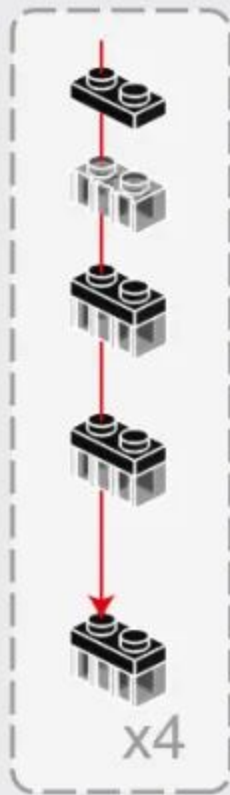

4-17

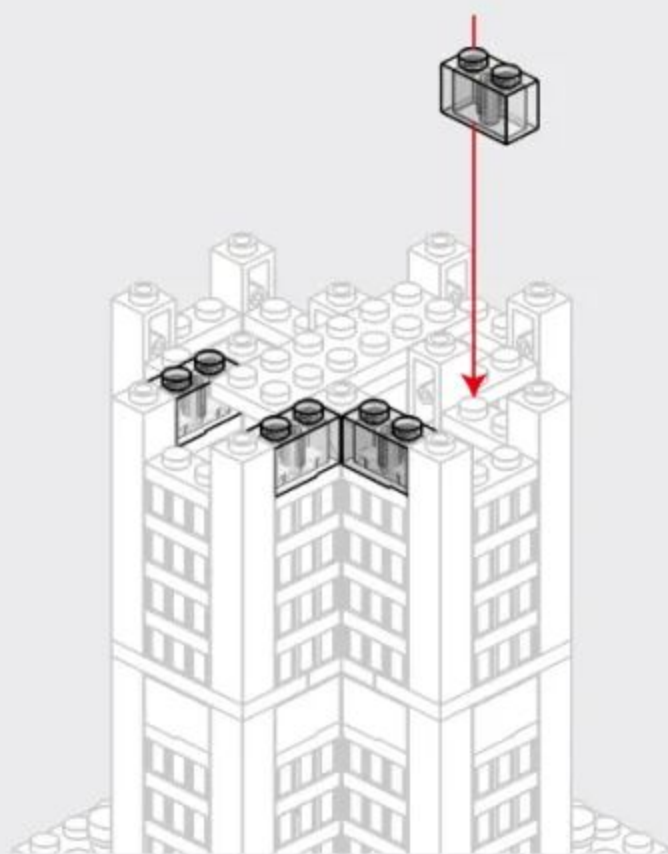

4-18

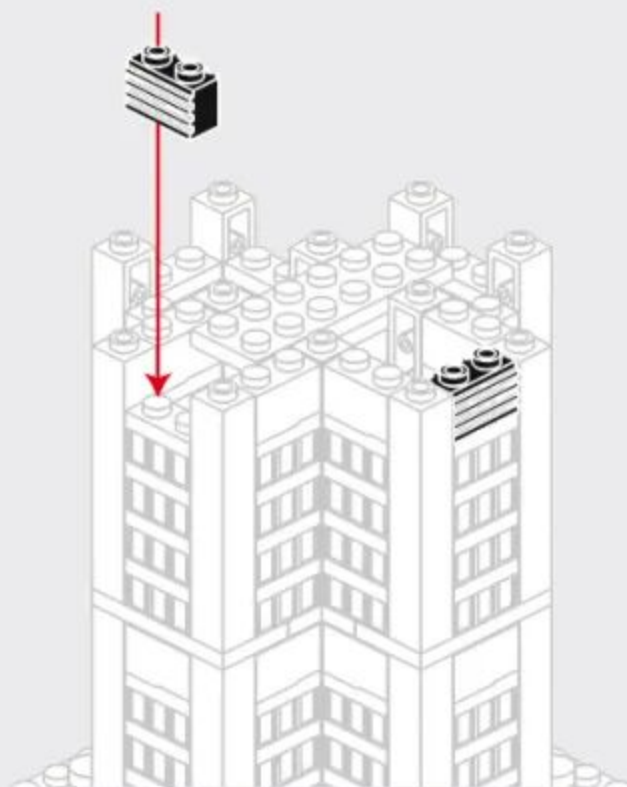

4-19

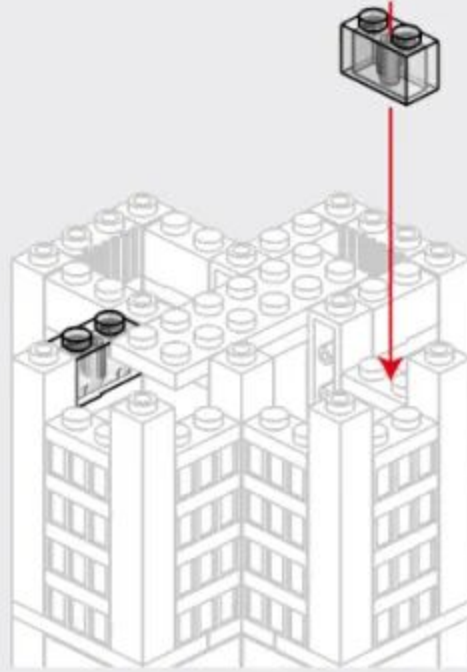

4-20

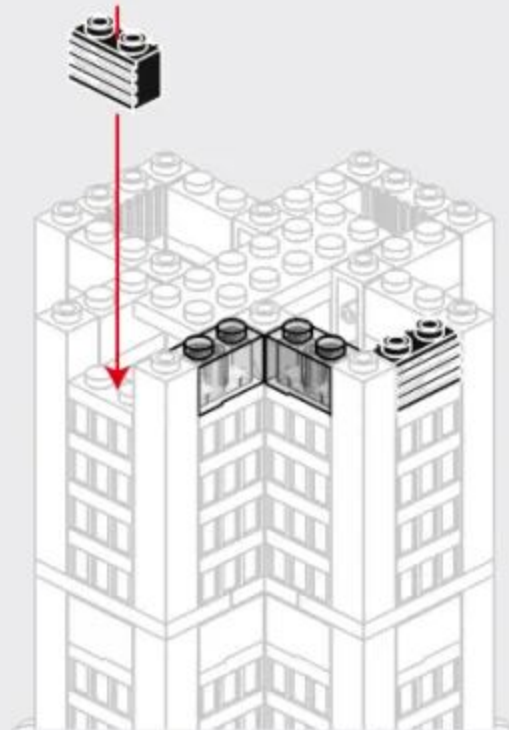
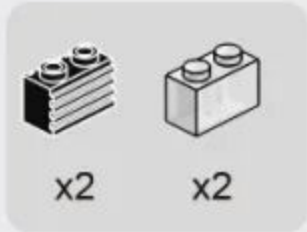

4-21

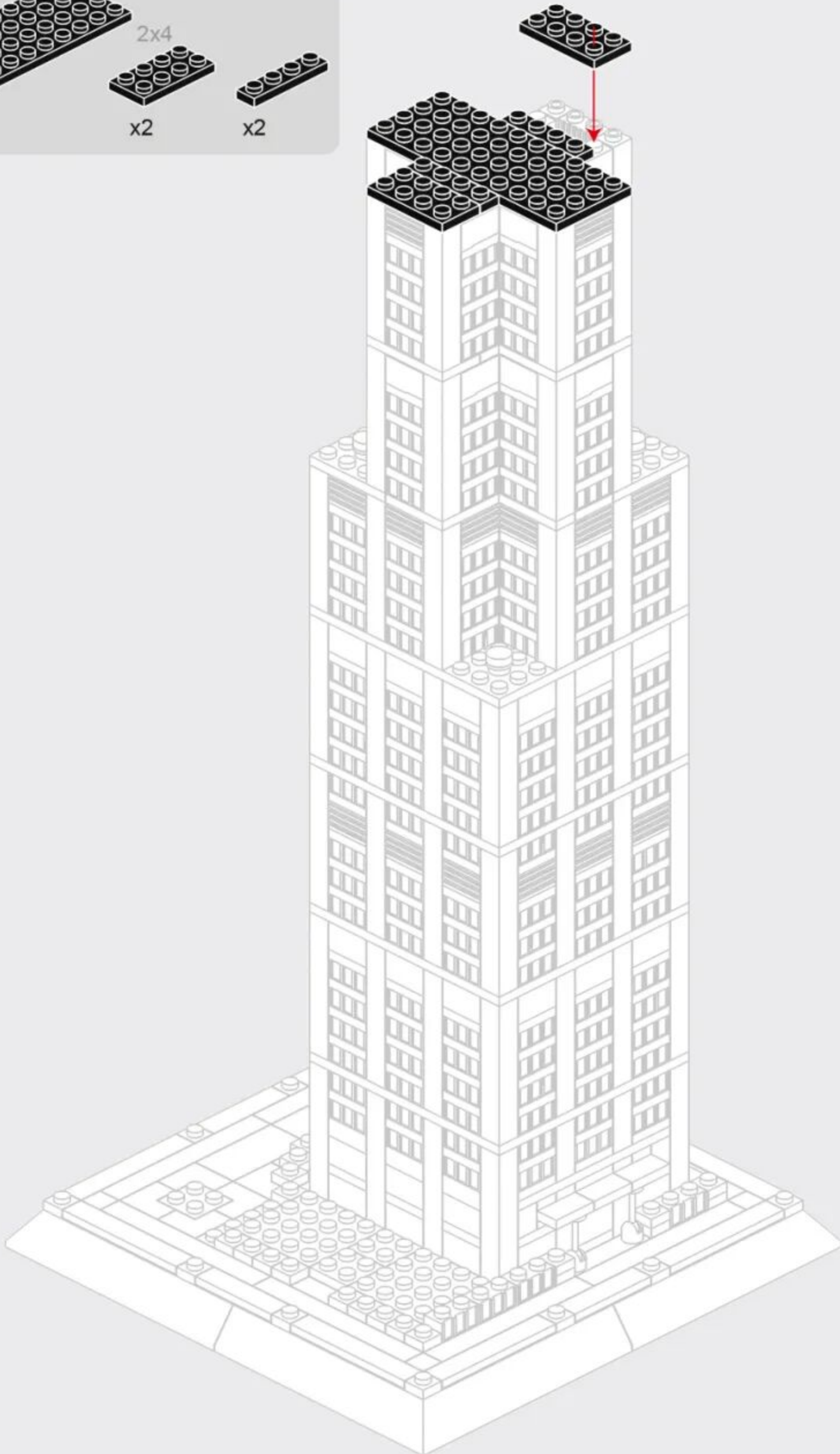
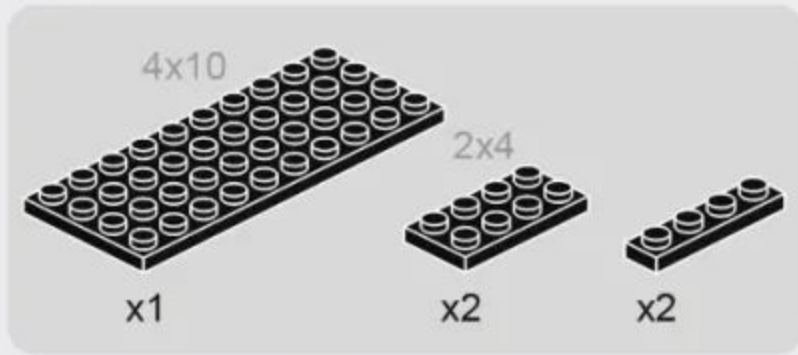



241PCS

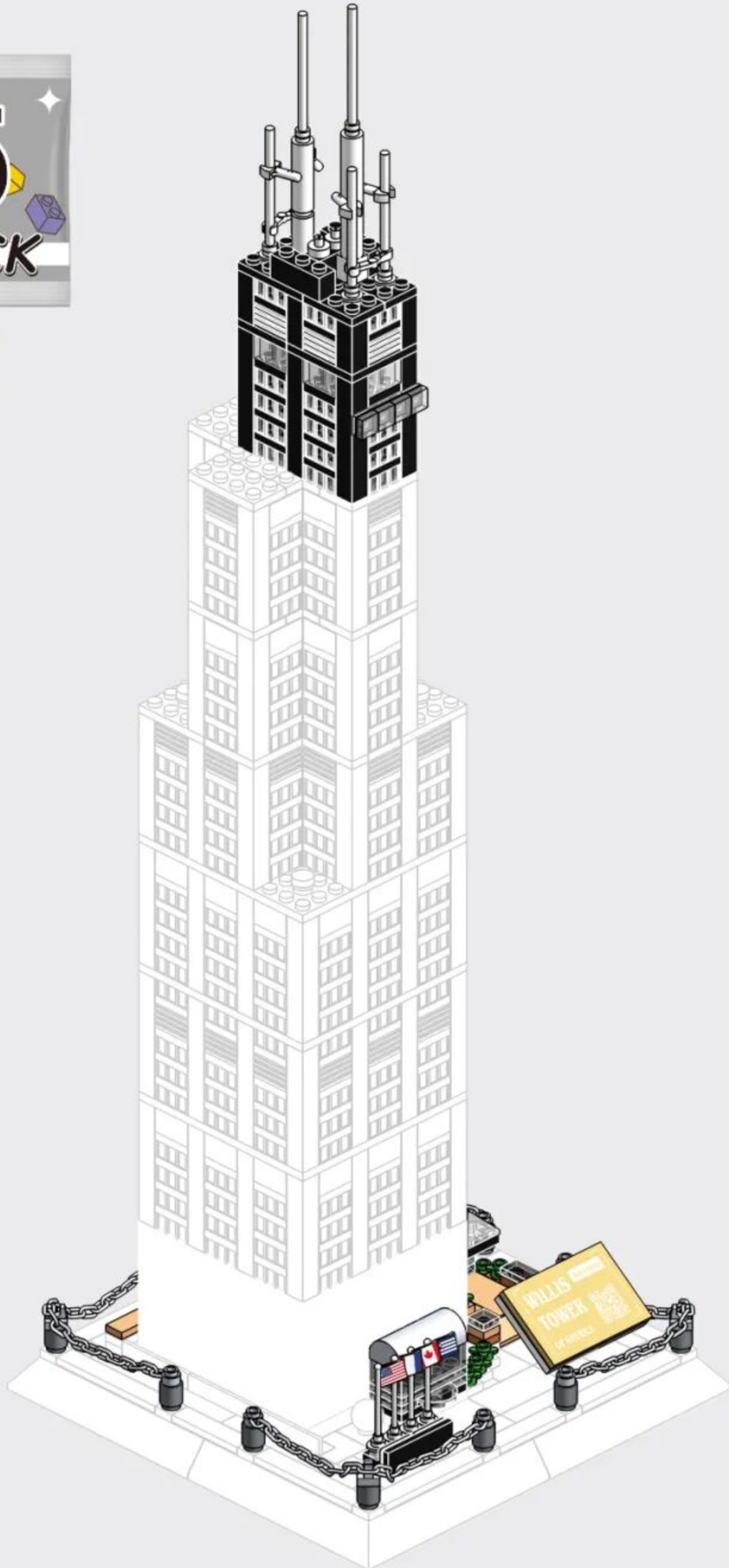

# 5-1

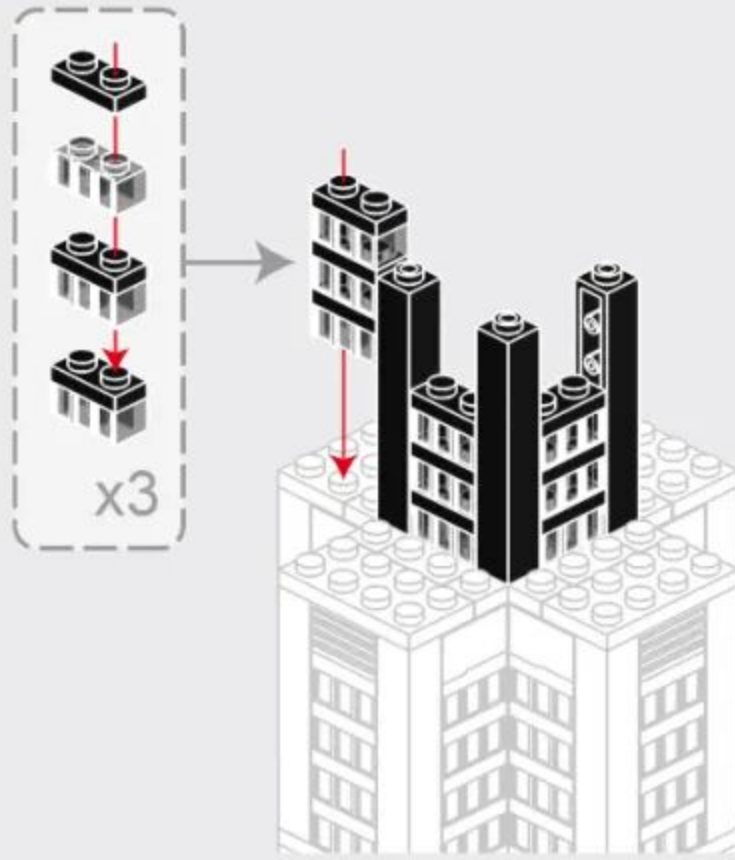
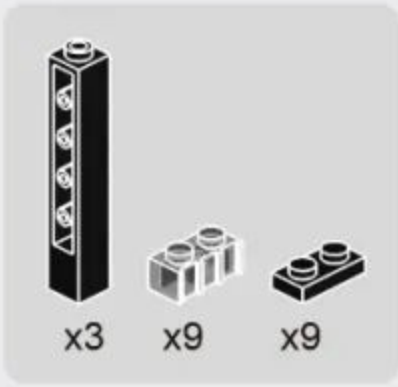

# 5-2

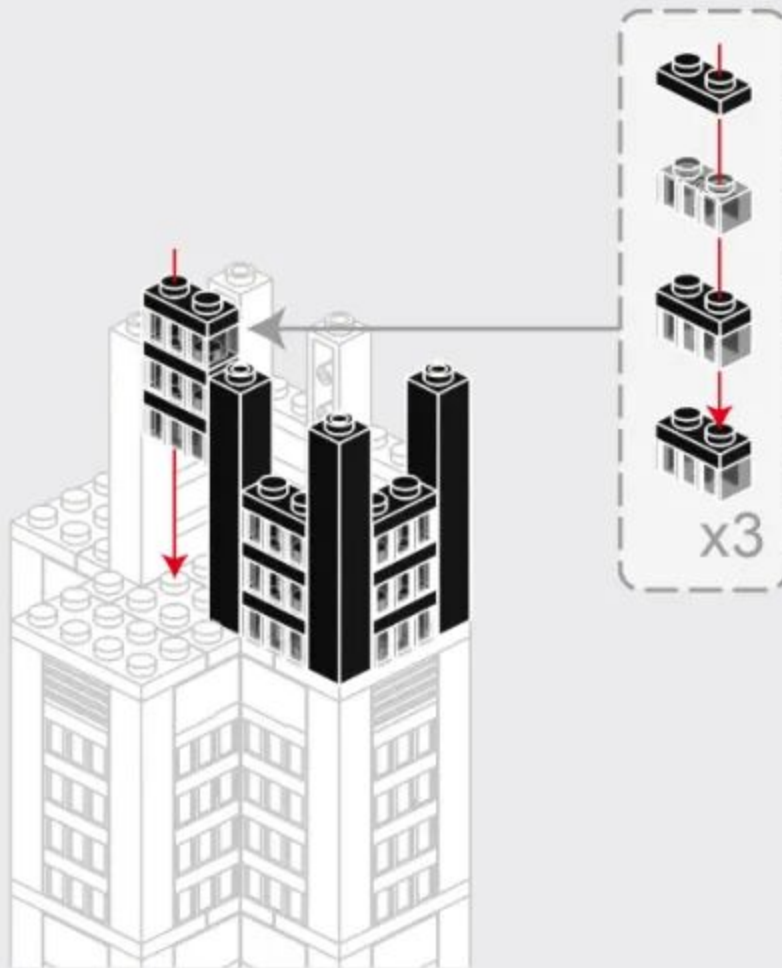
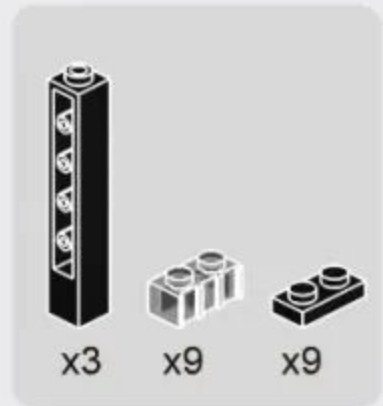

### 5-3

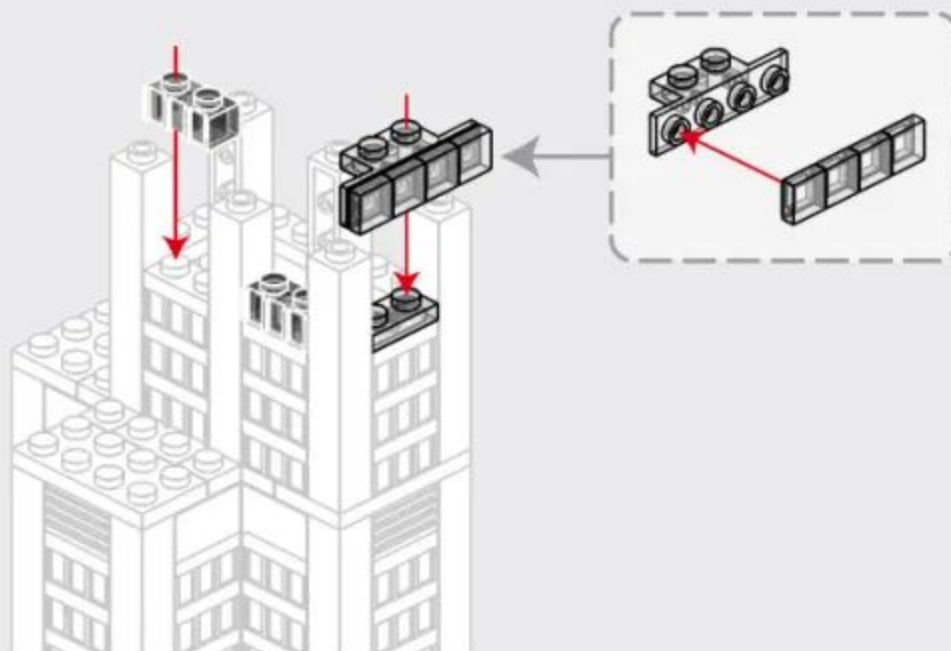
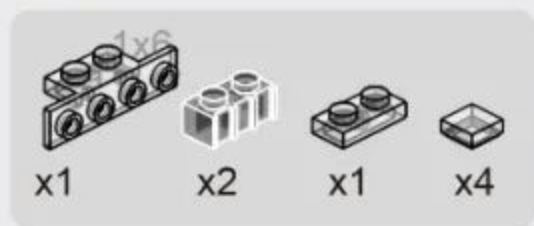

### 5-4

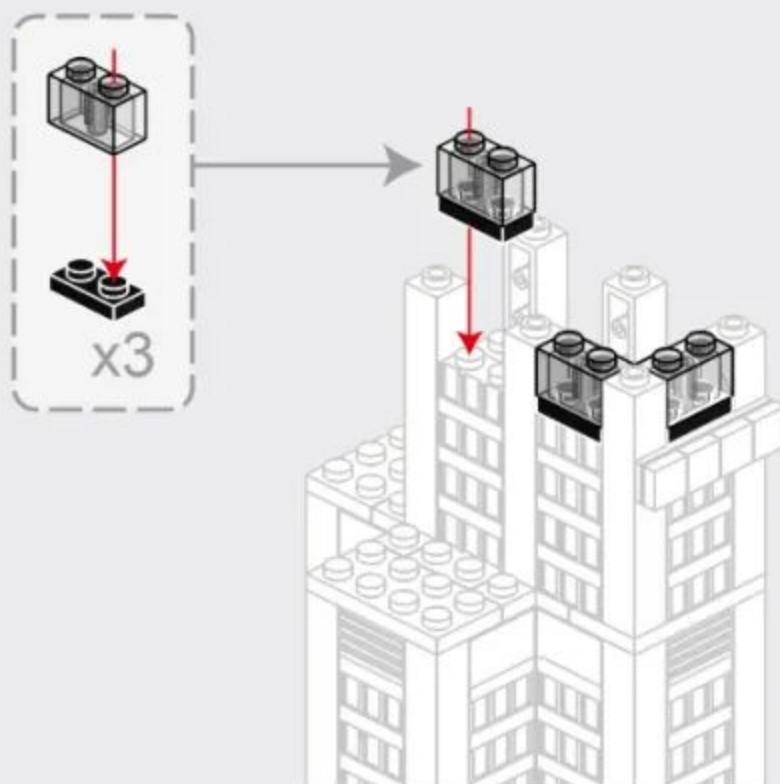

## 5-5

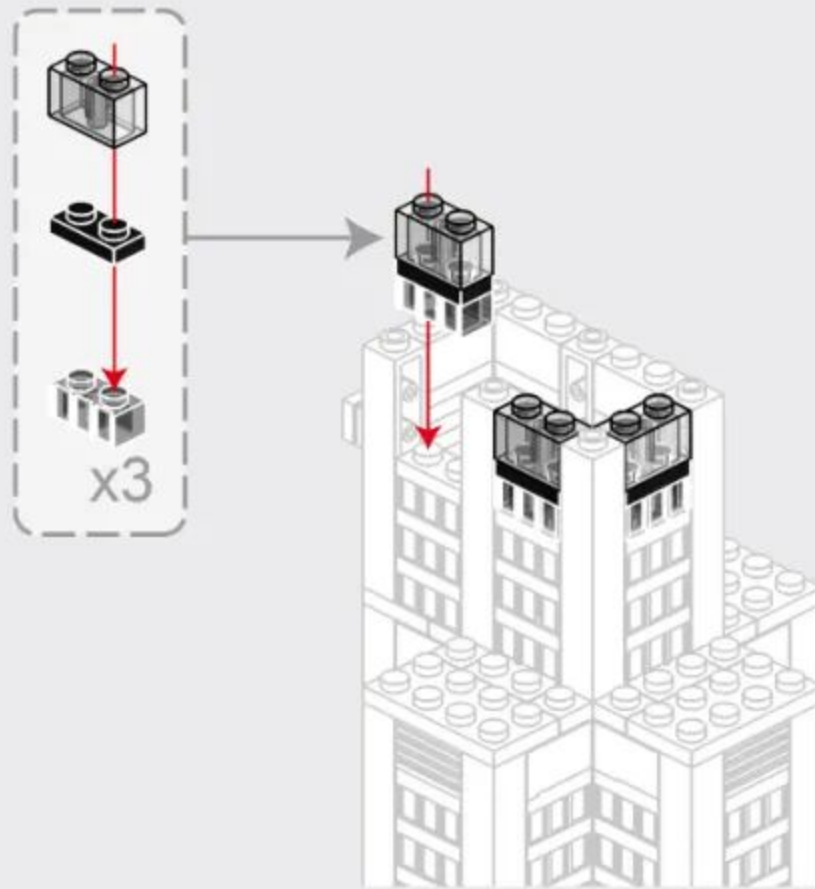

## 5-6

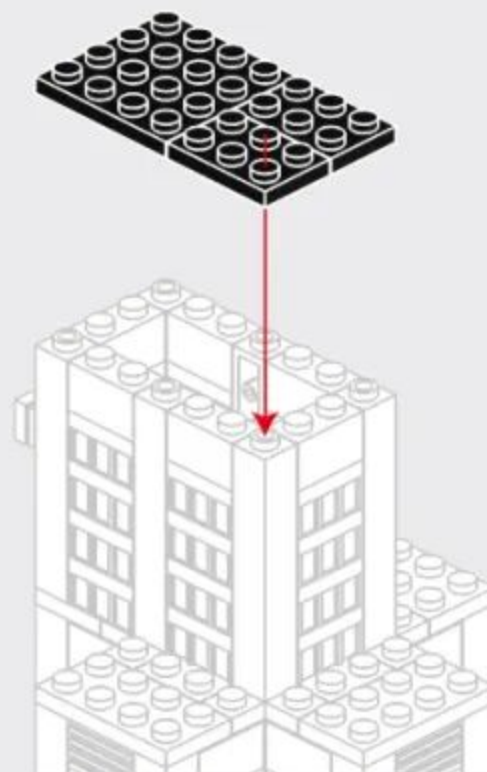
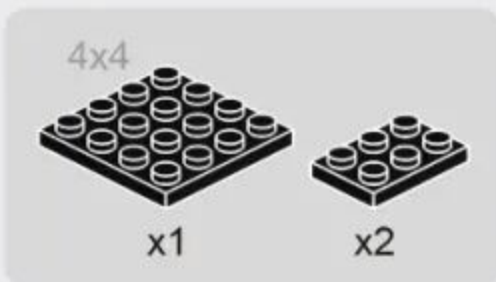

5-7

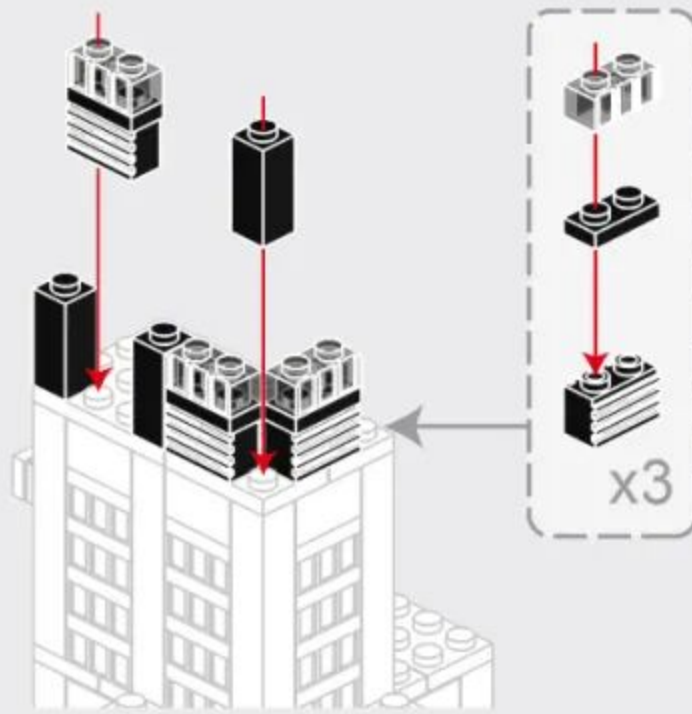

5-8

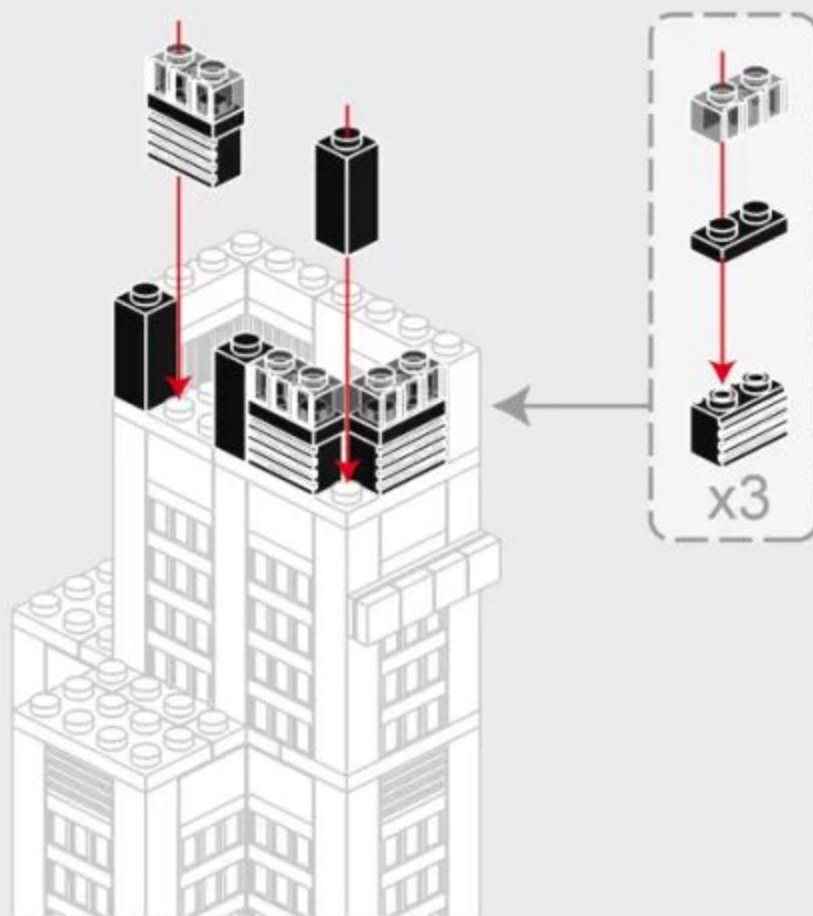

# 5-9

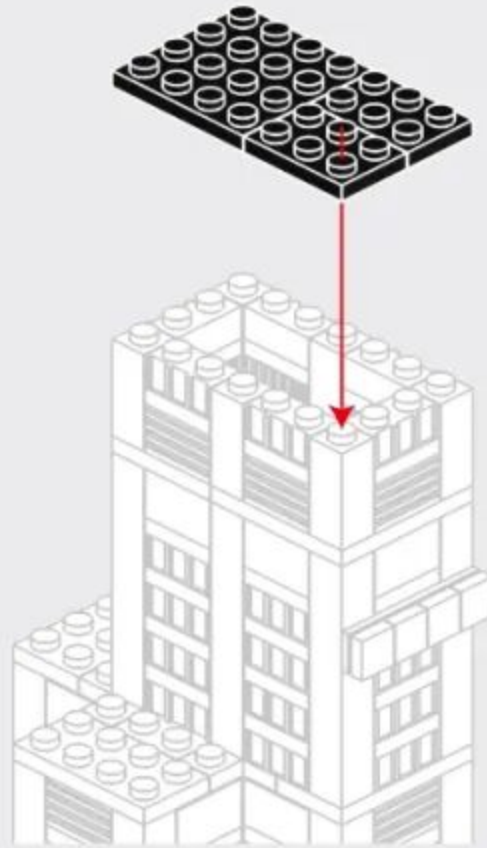
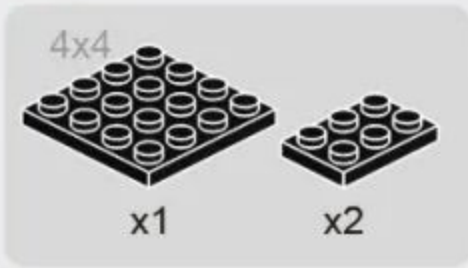

# 5-10



# 5-11

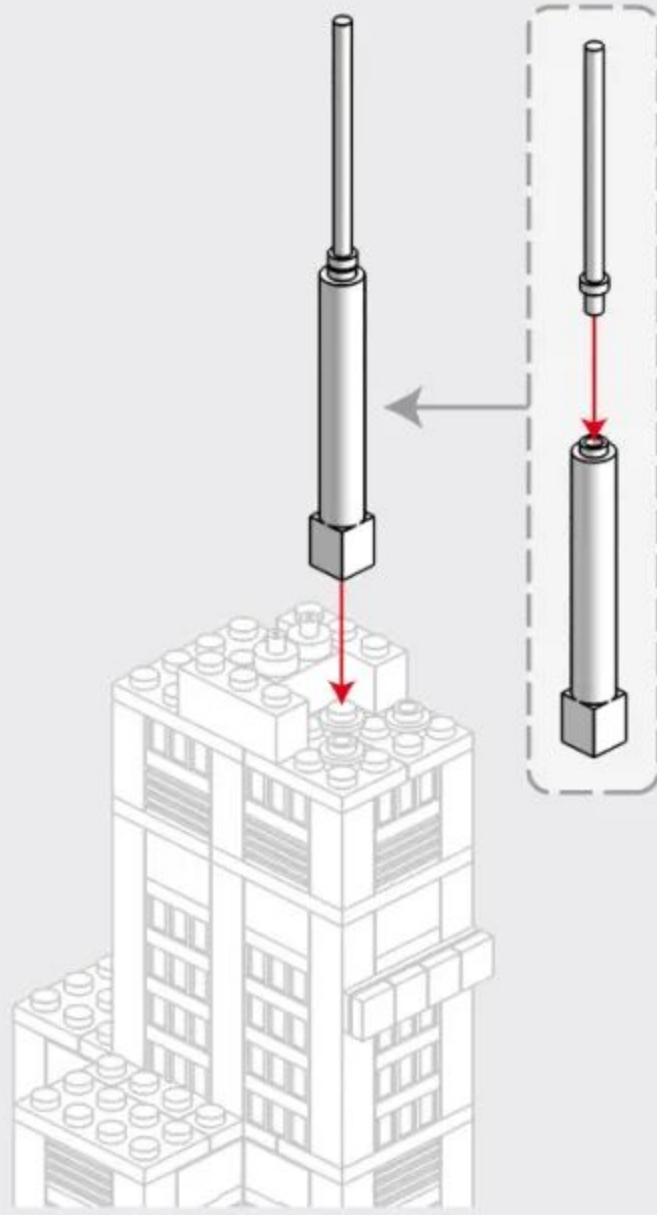
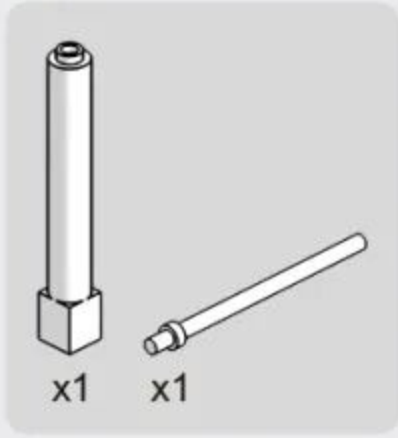

# 5-12

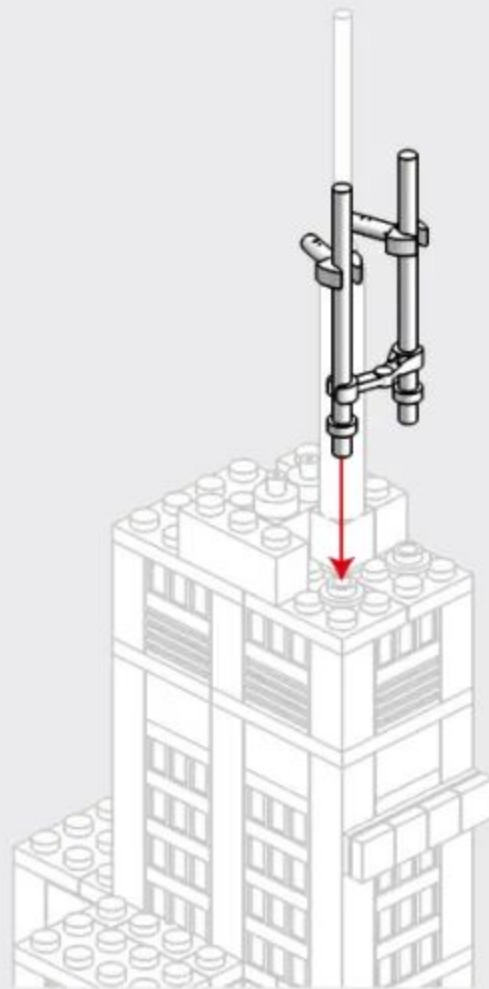
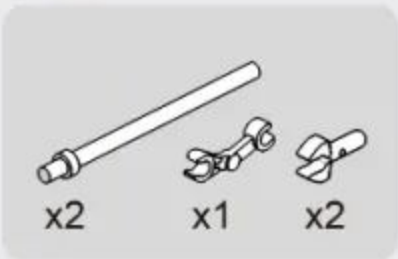

### 5-13

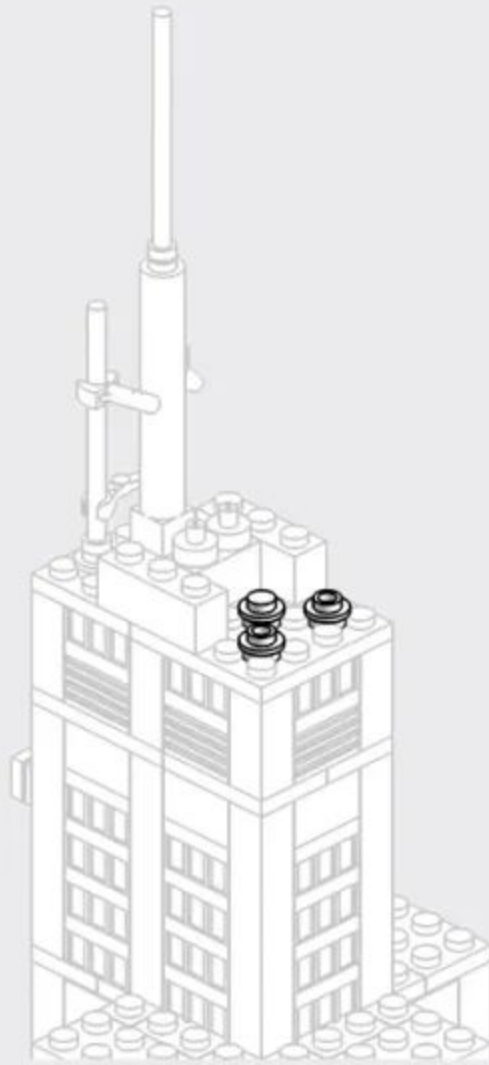

### 5-14

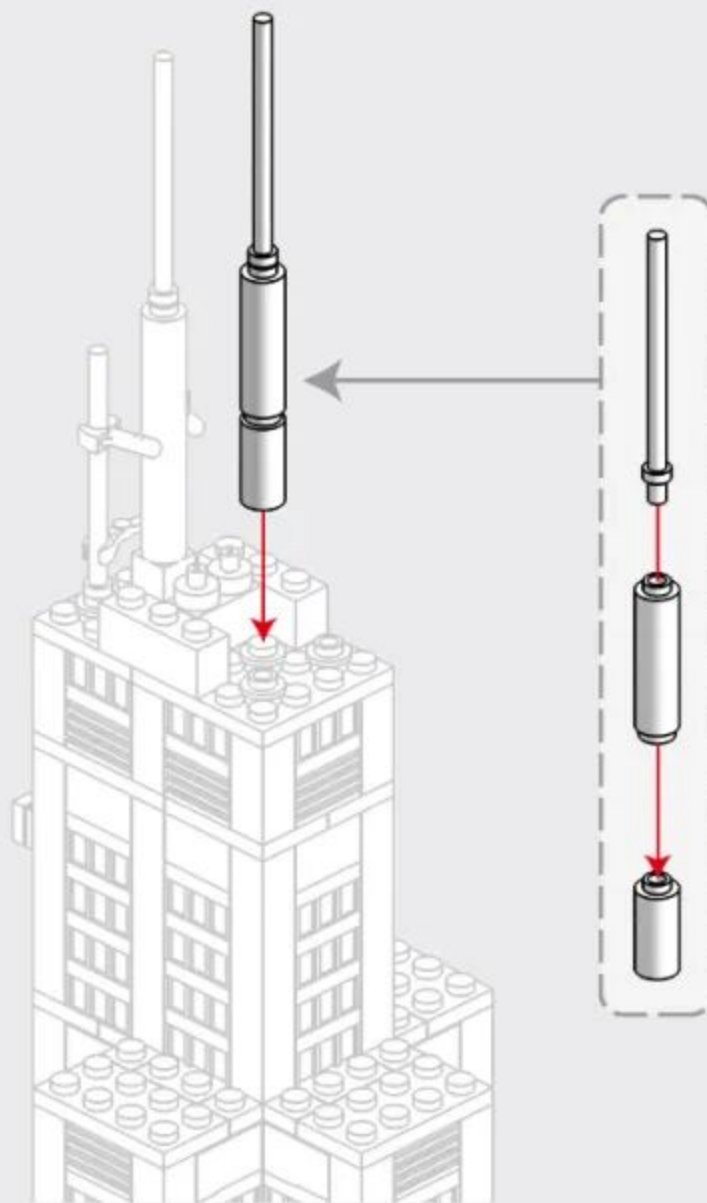
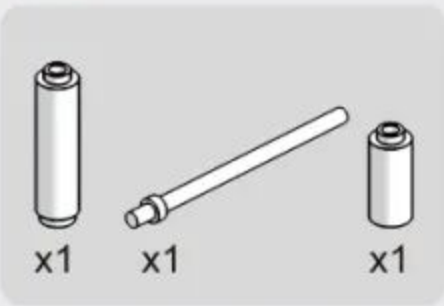

# 5-15

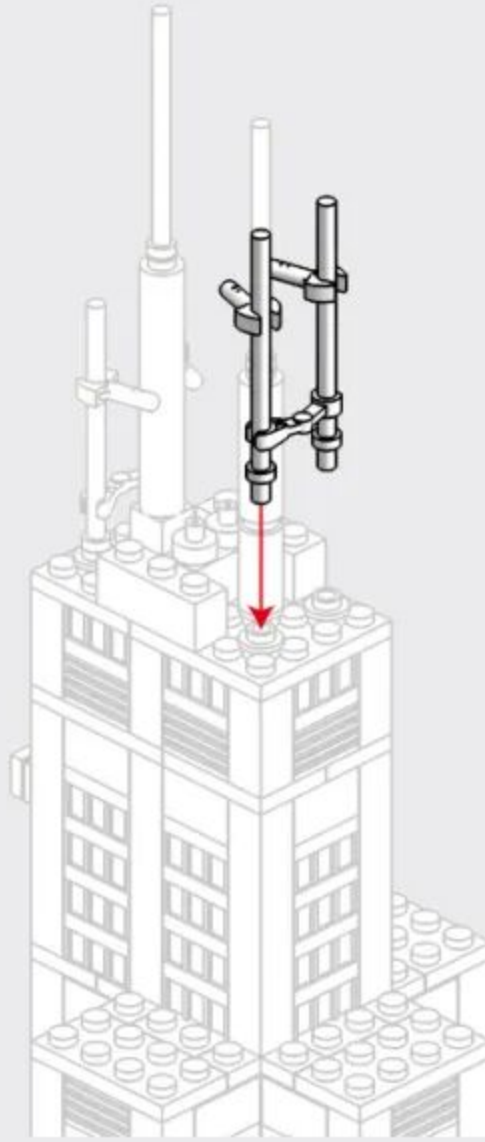
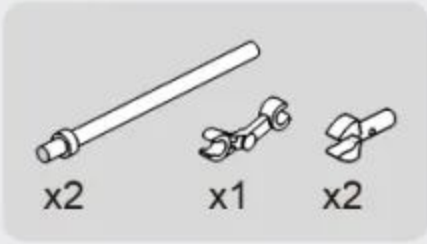

# 5-16

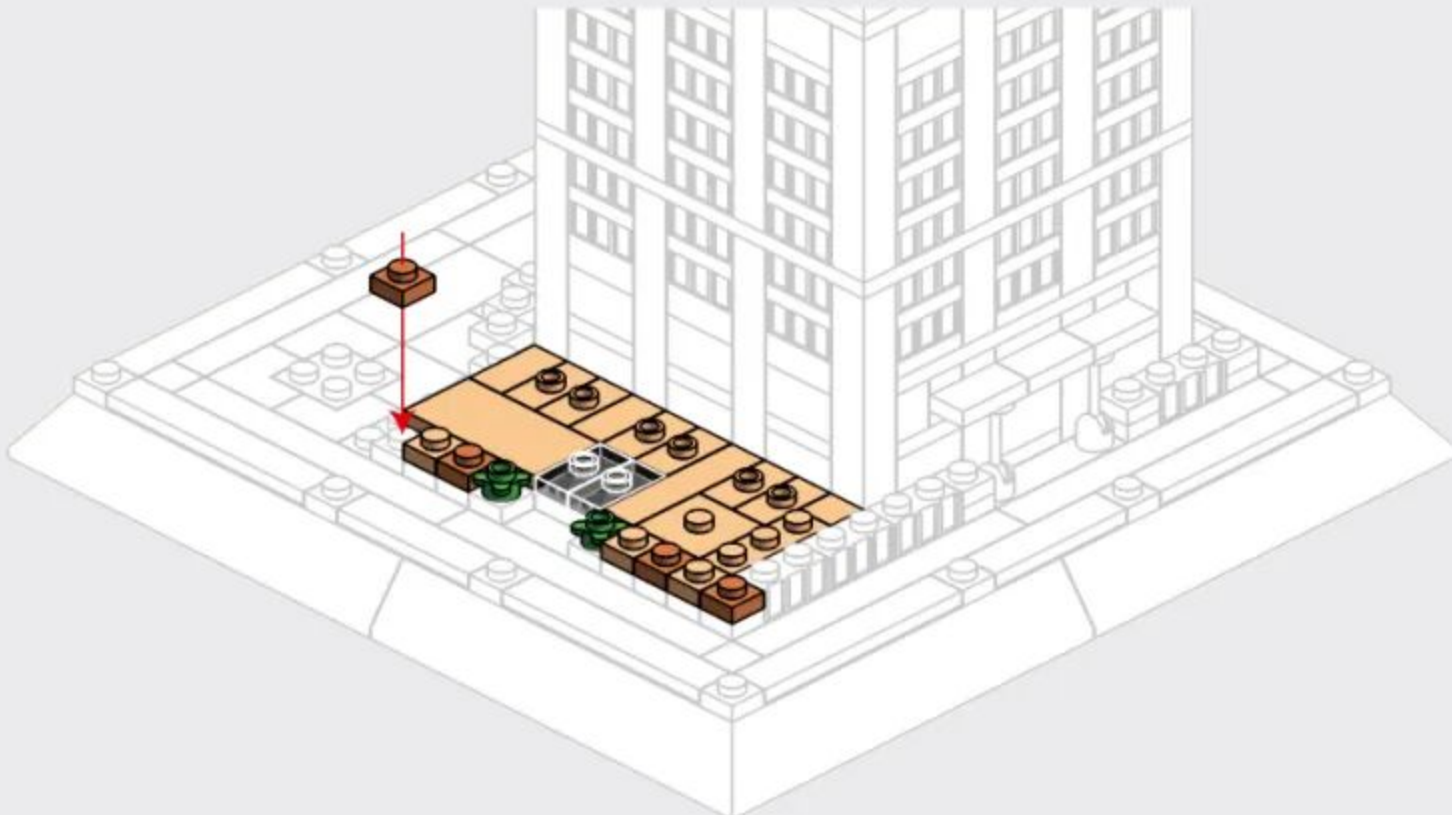
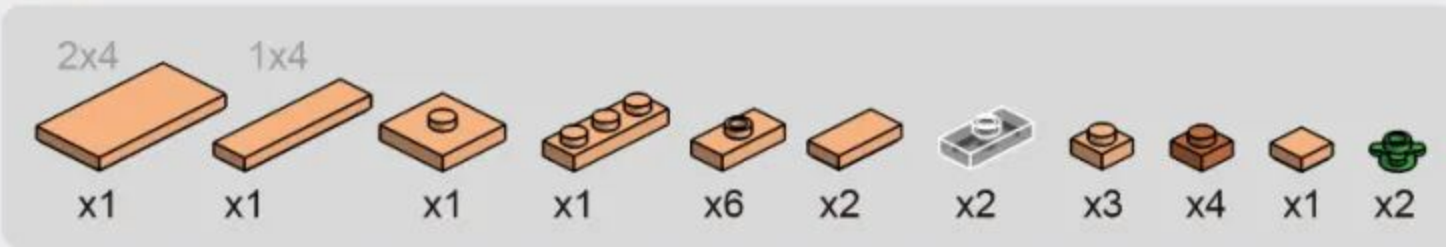

# 5-17

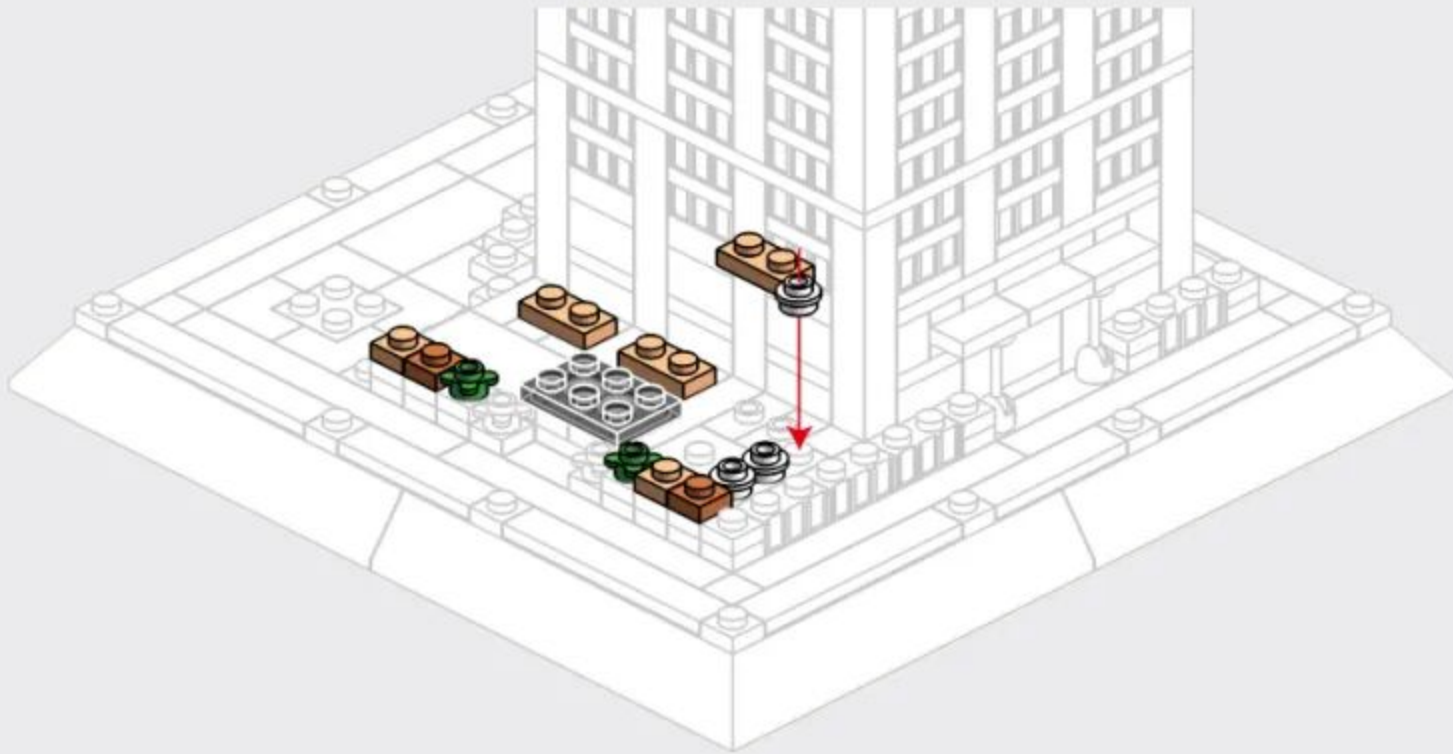
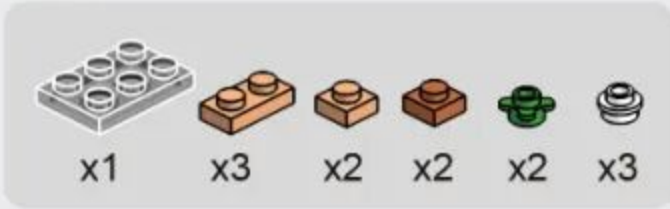

# 5-18

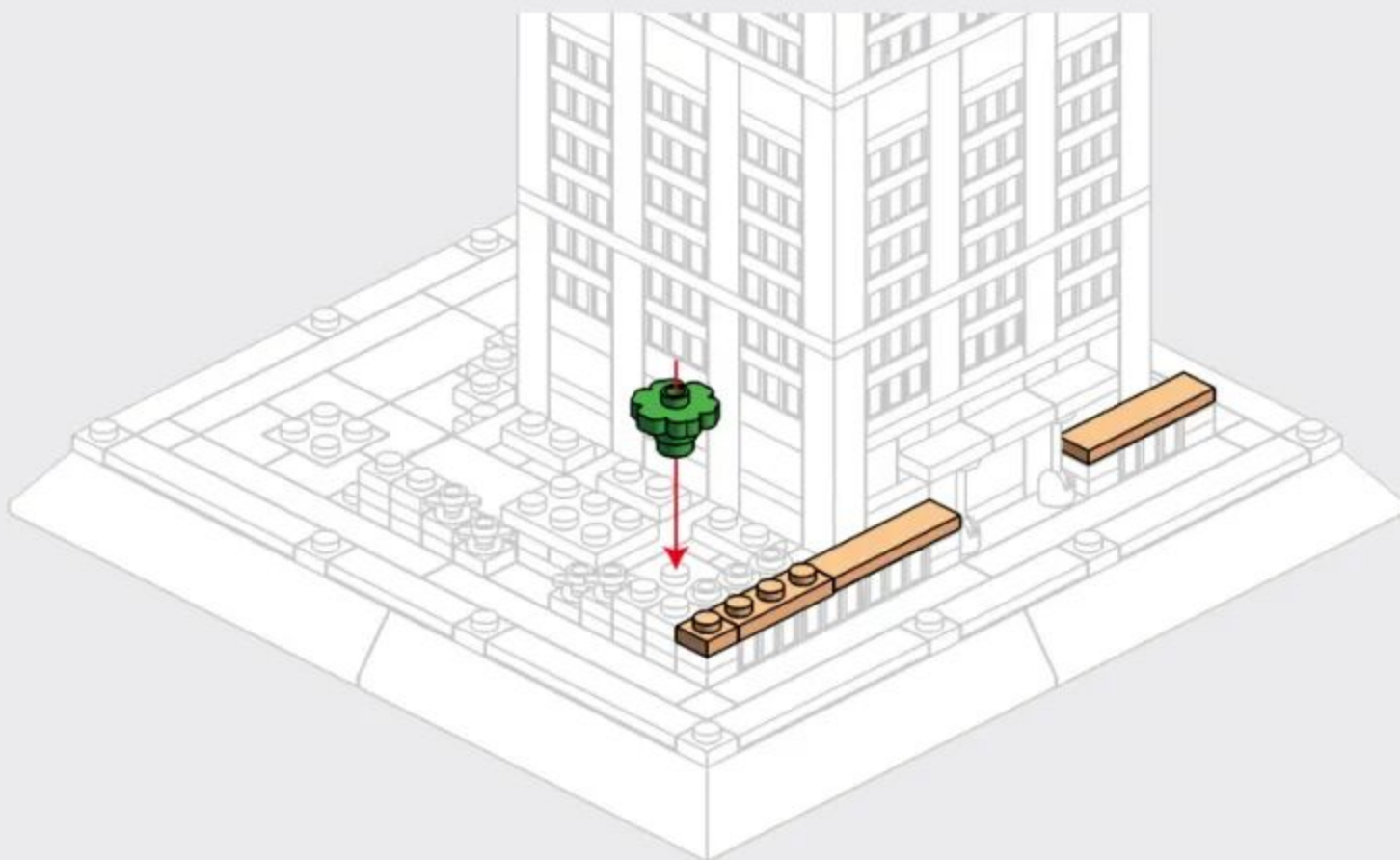
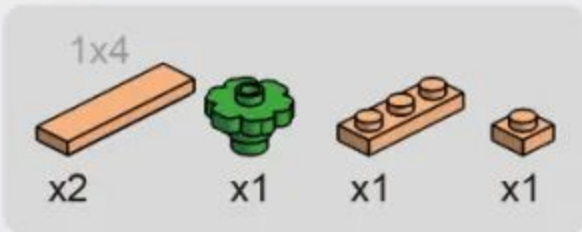

# 5-19

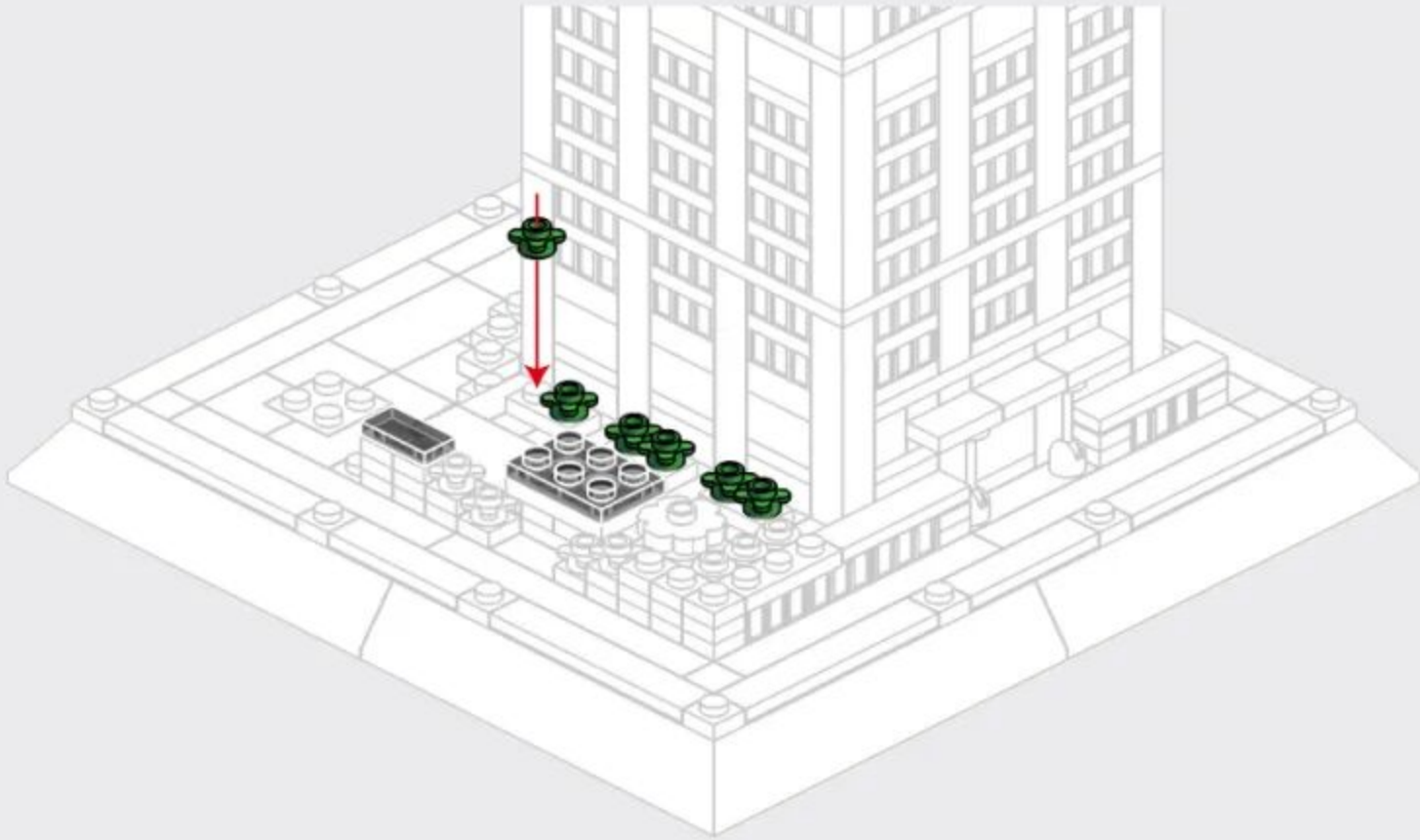
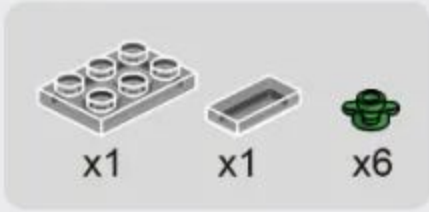

# 5-20

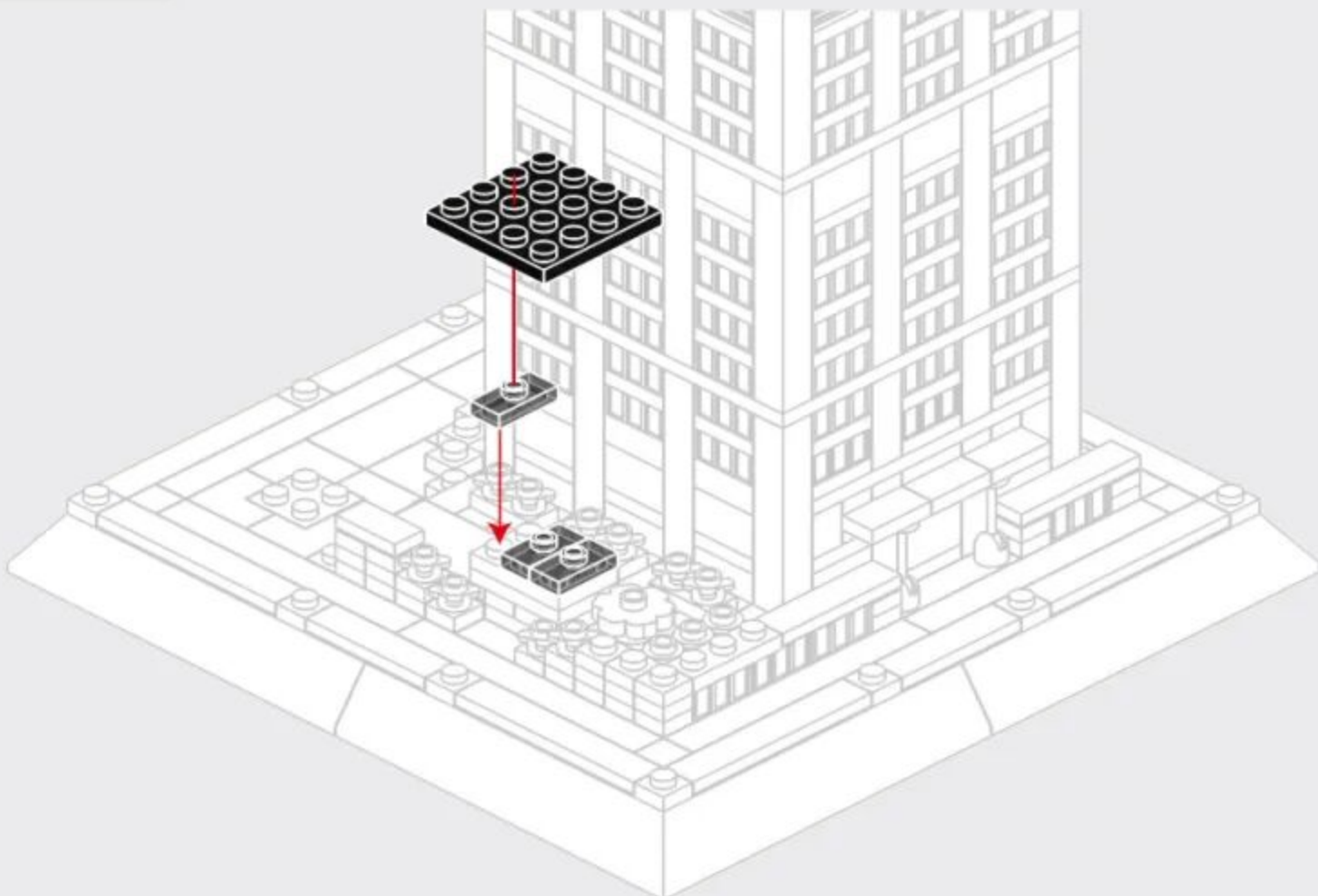
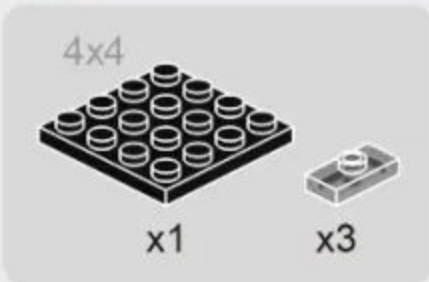

5-21

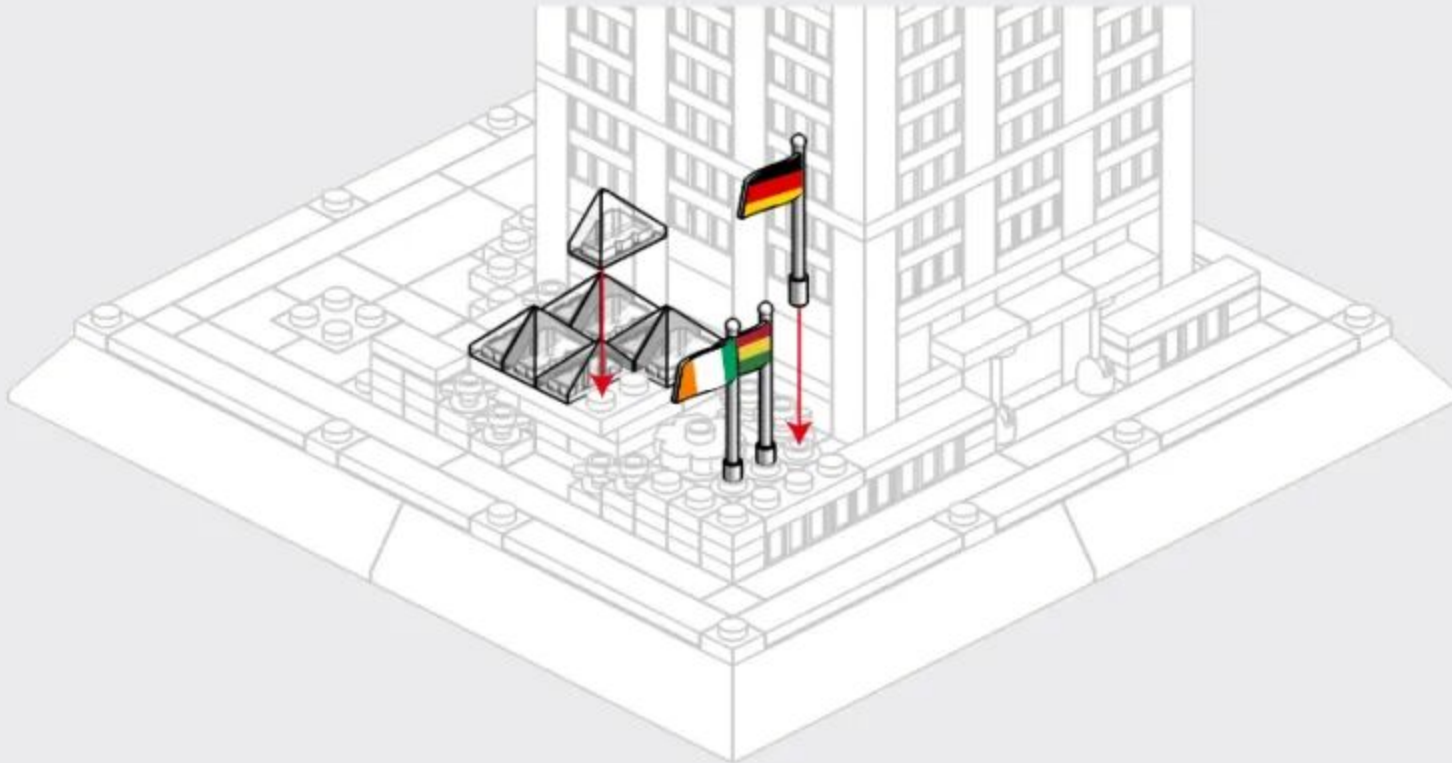
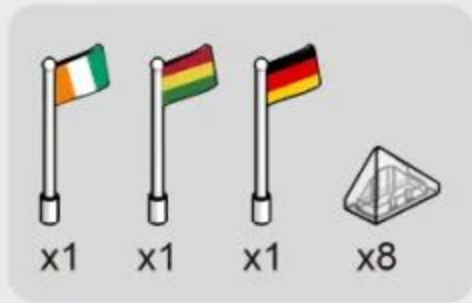

5-22

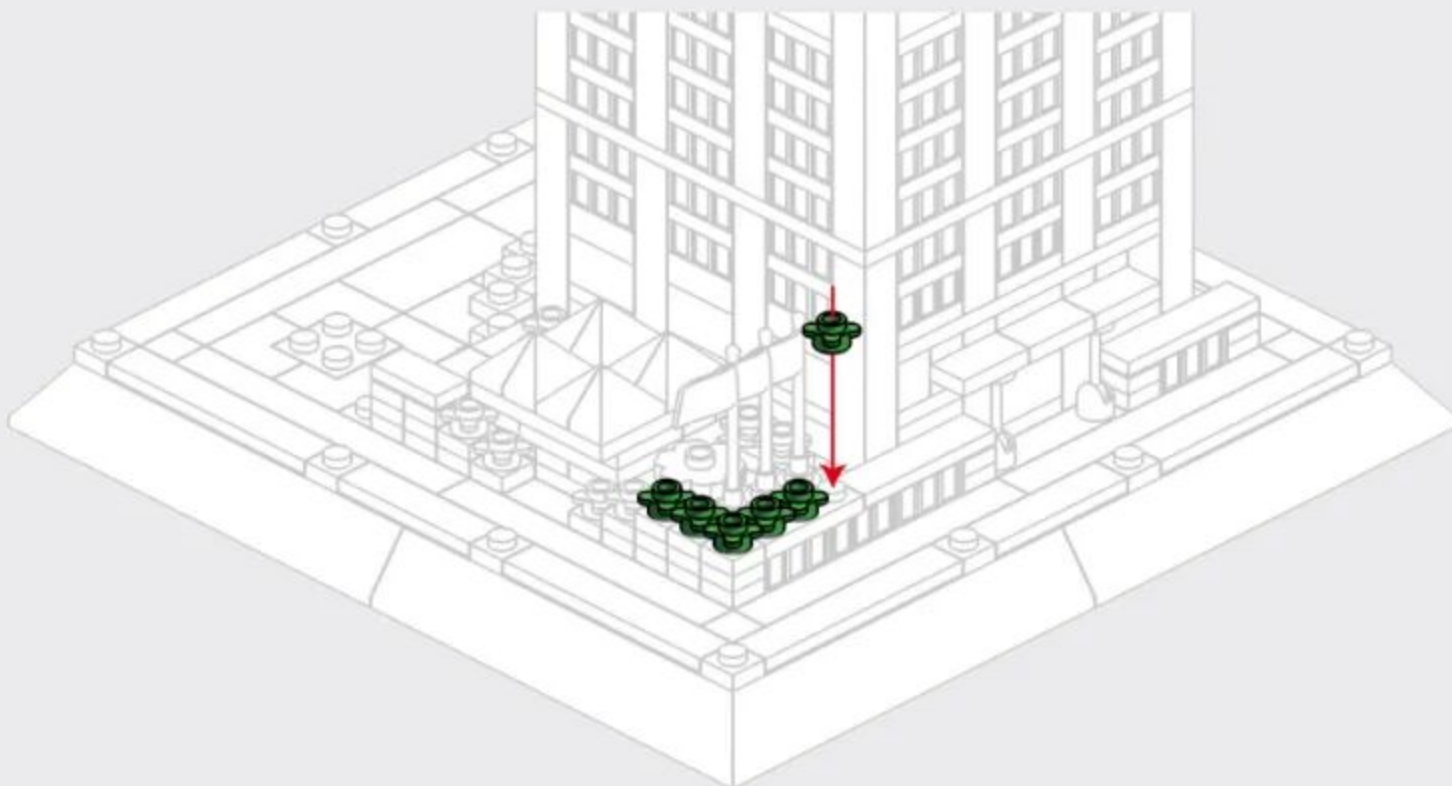
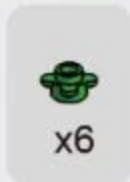

# 5-23

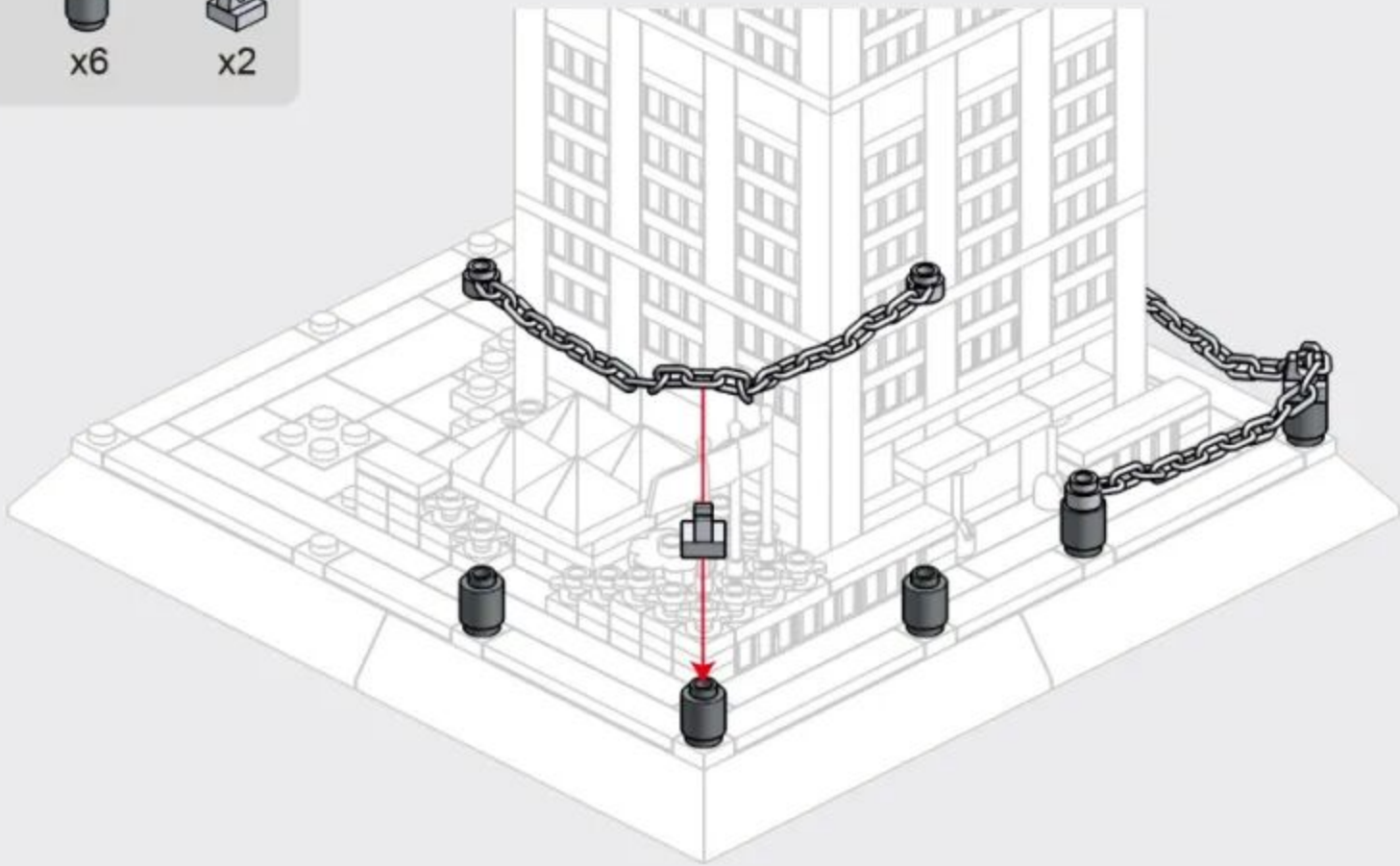
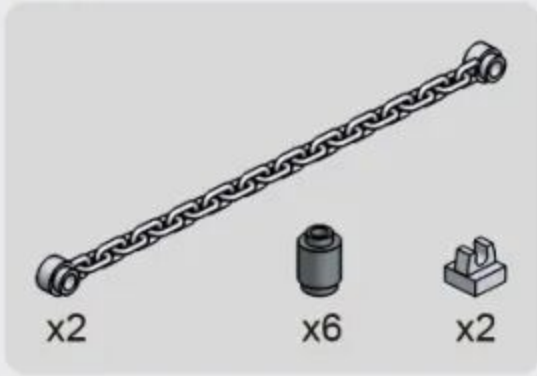

# 5-24

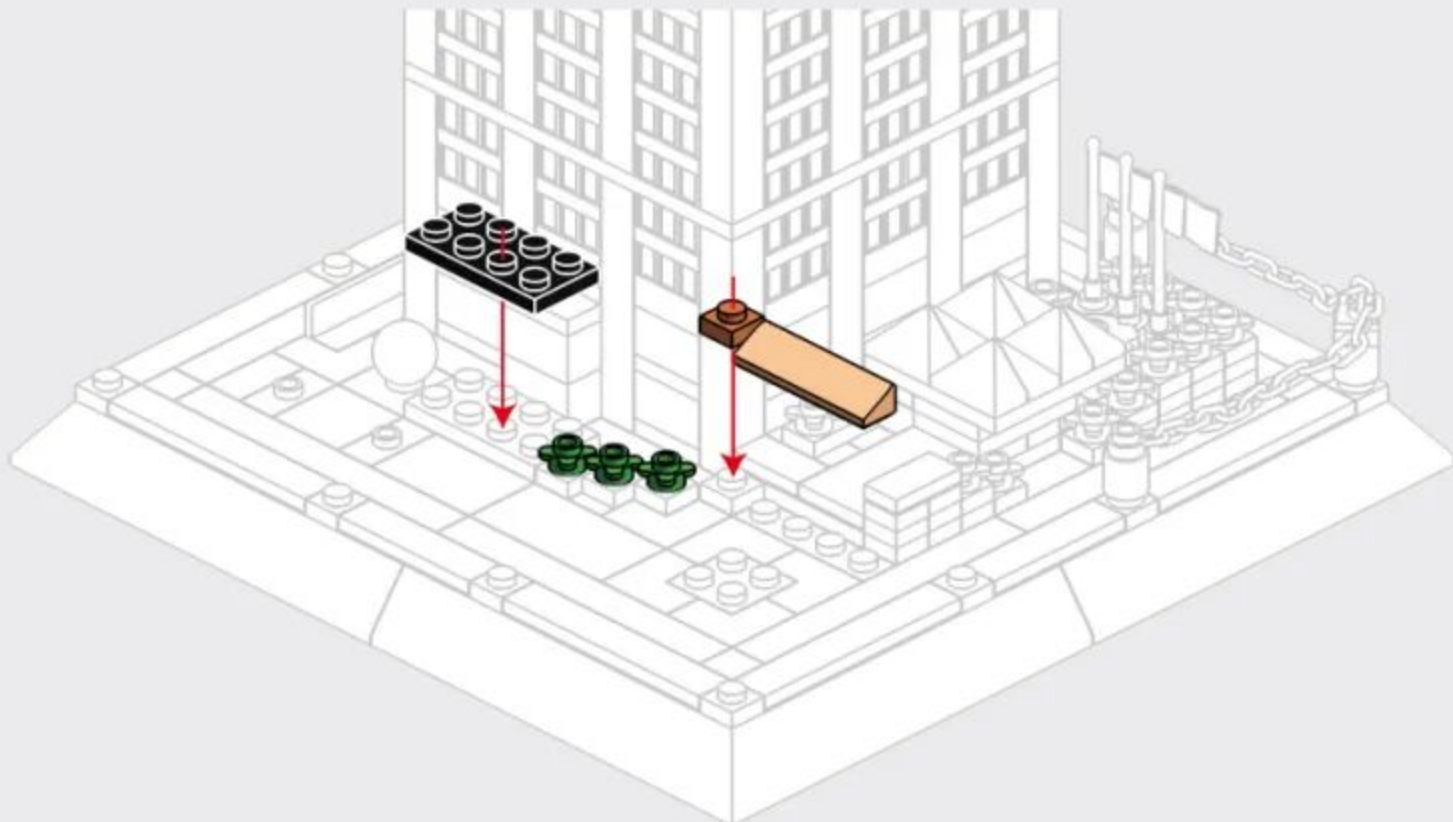

5-25

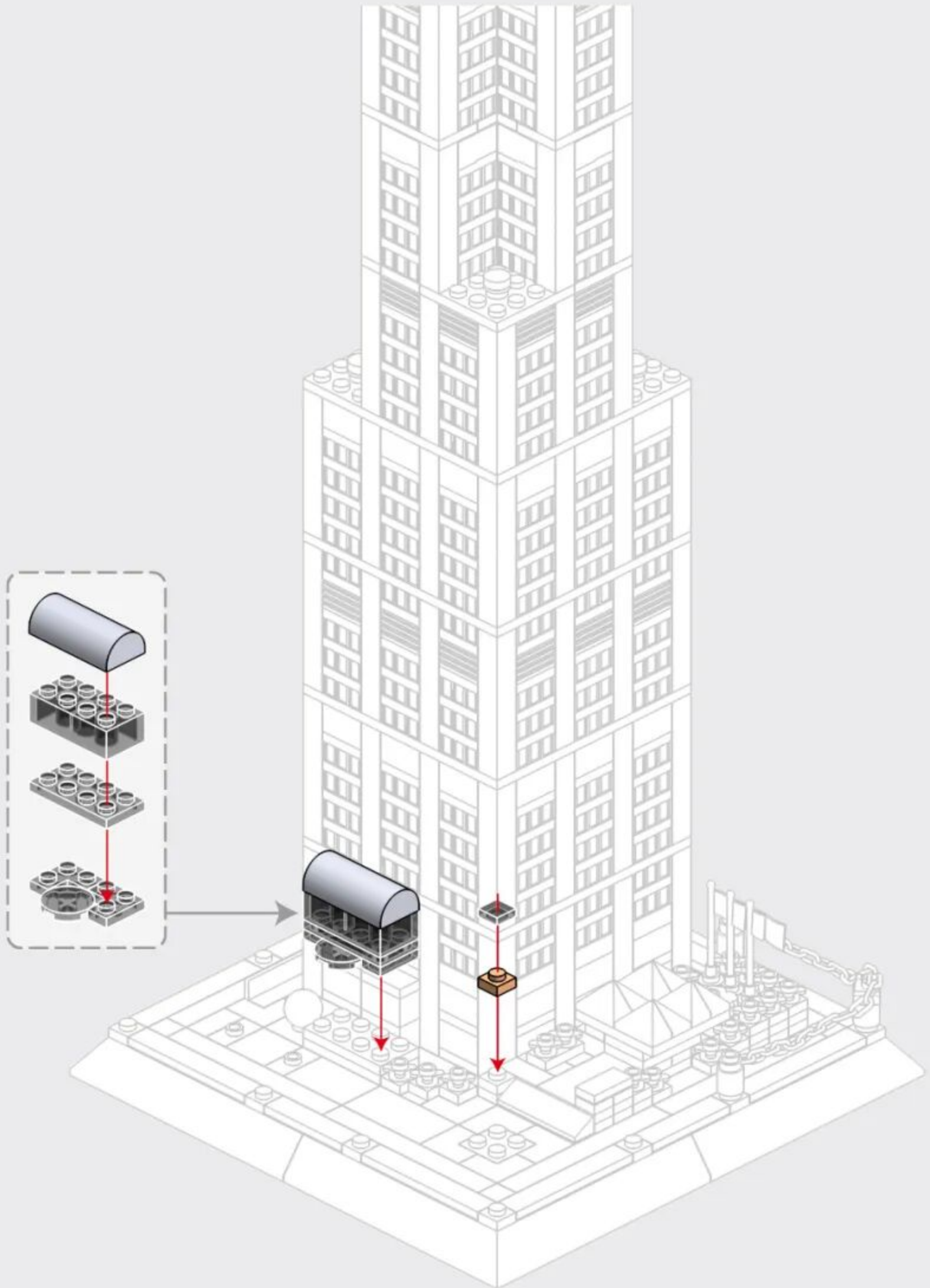
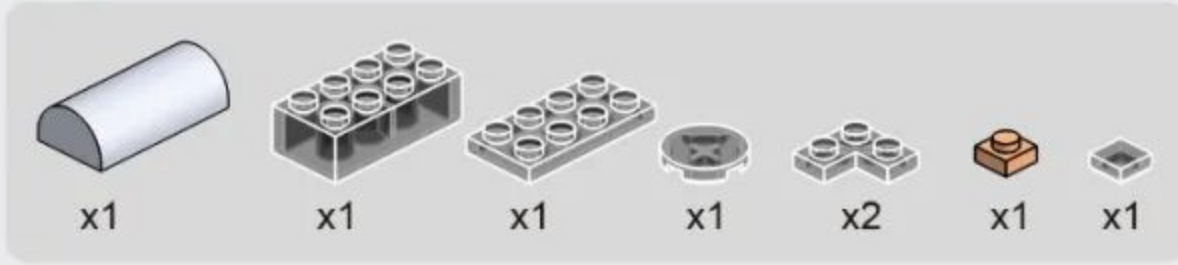

5-26

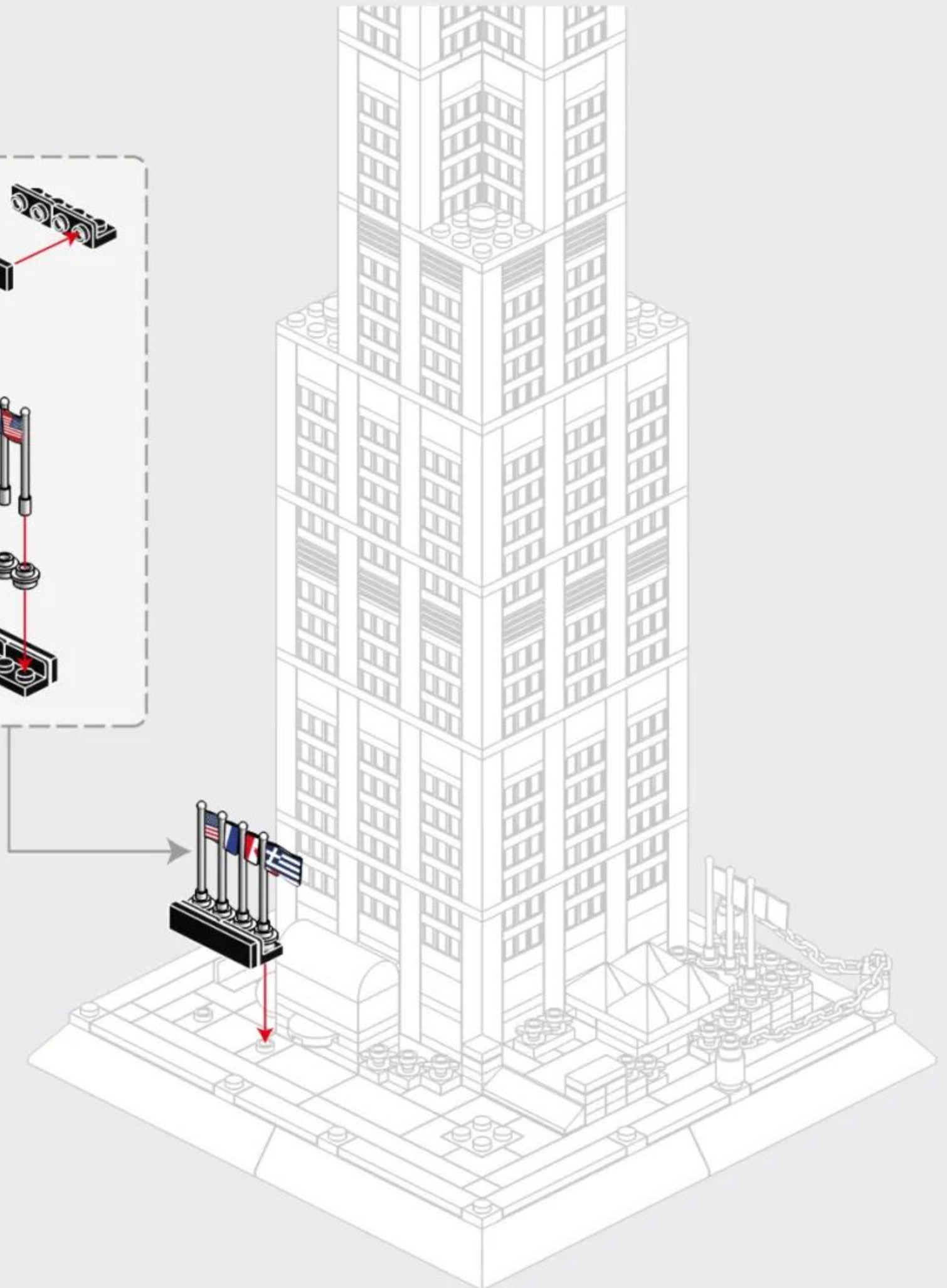
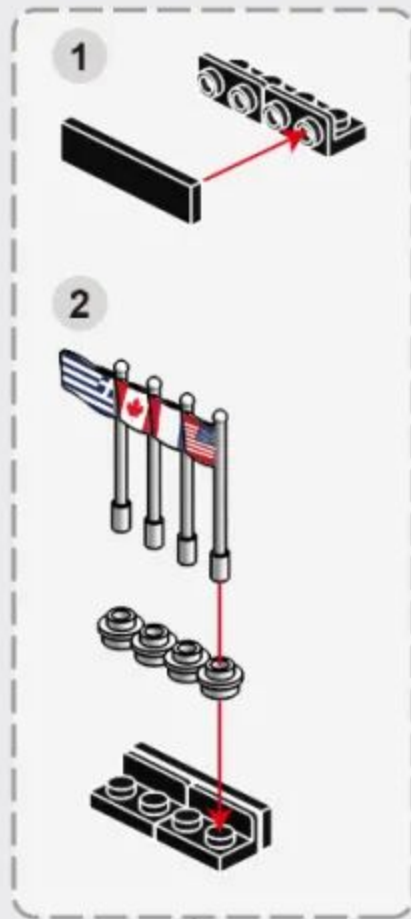
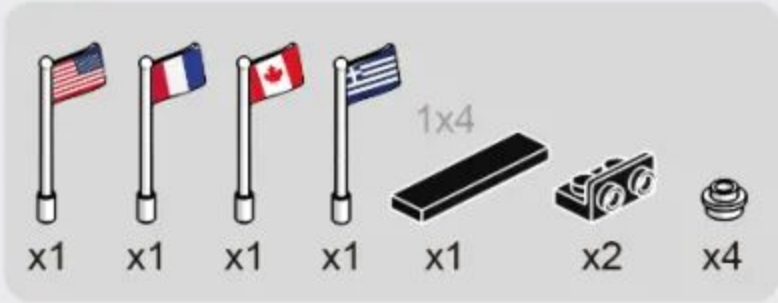

5-27

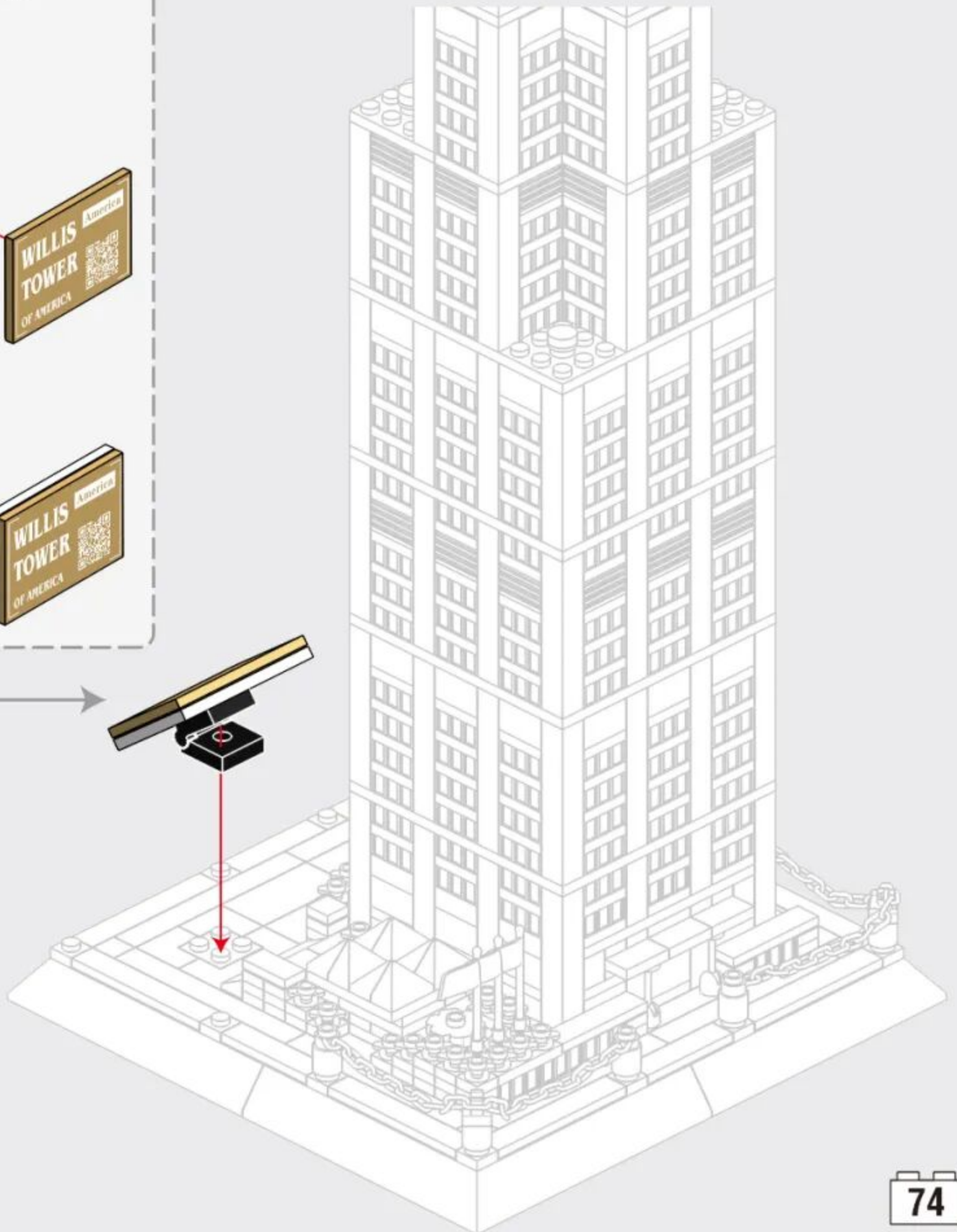
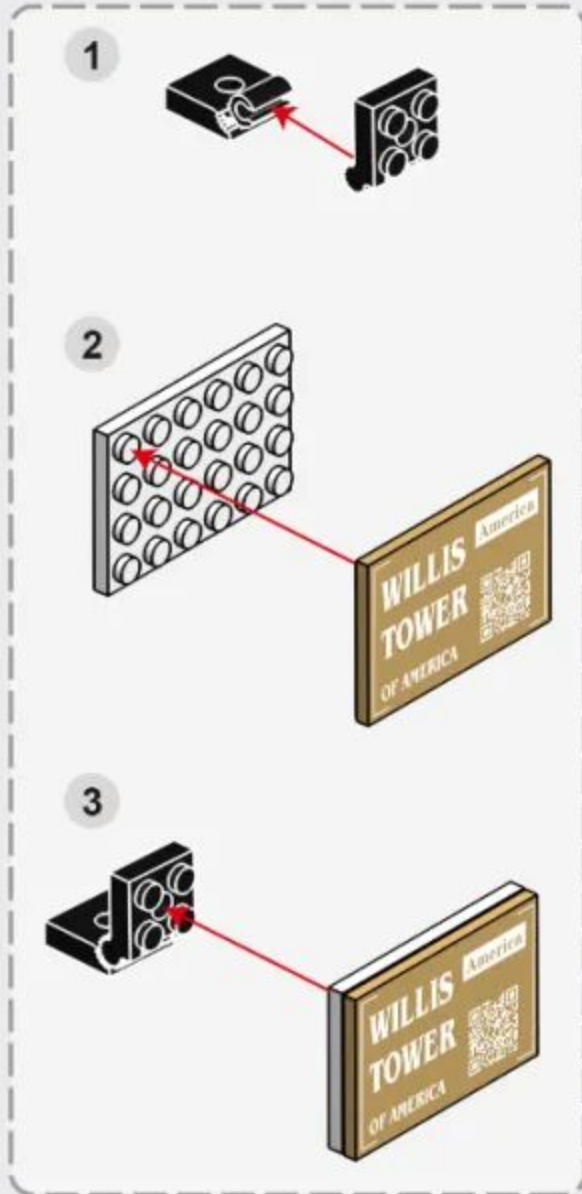
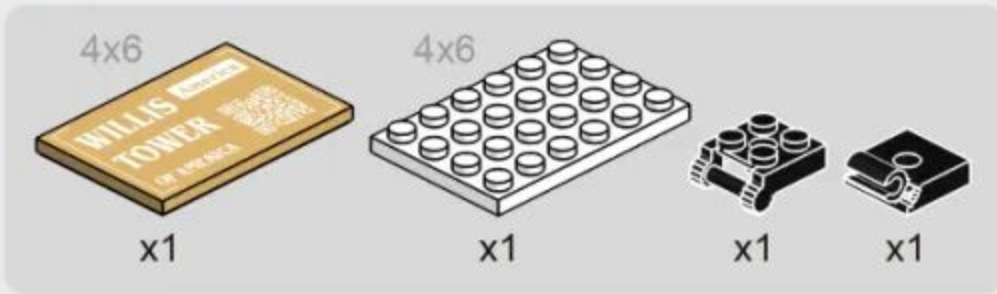

5-28

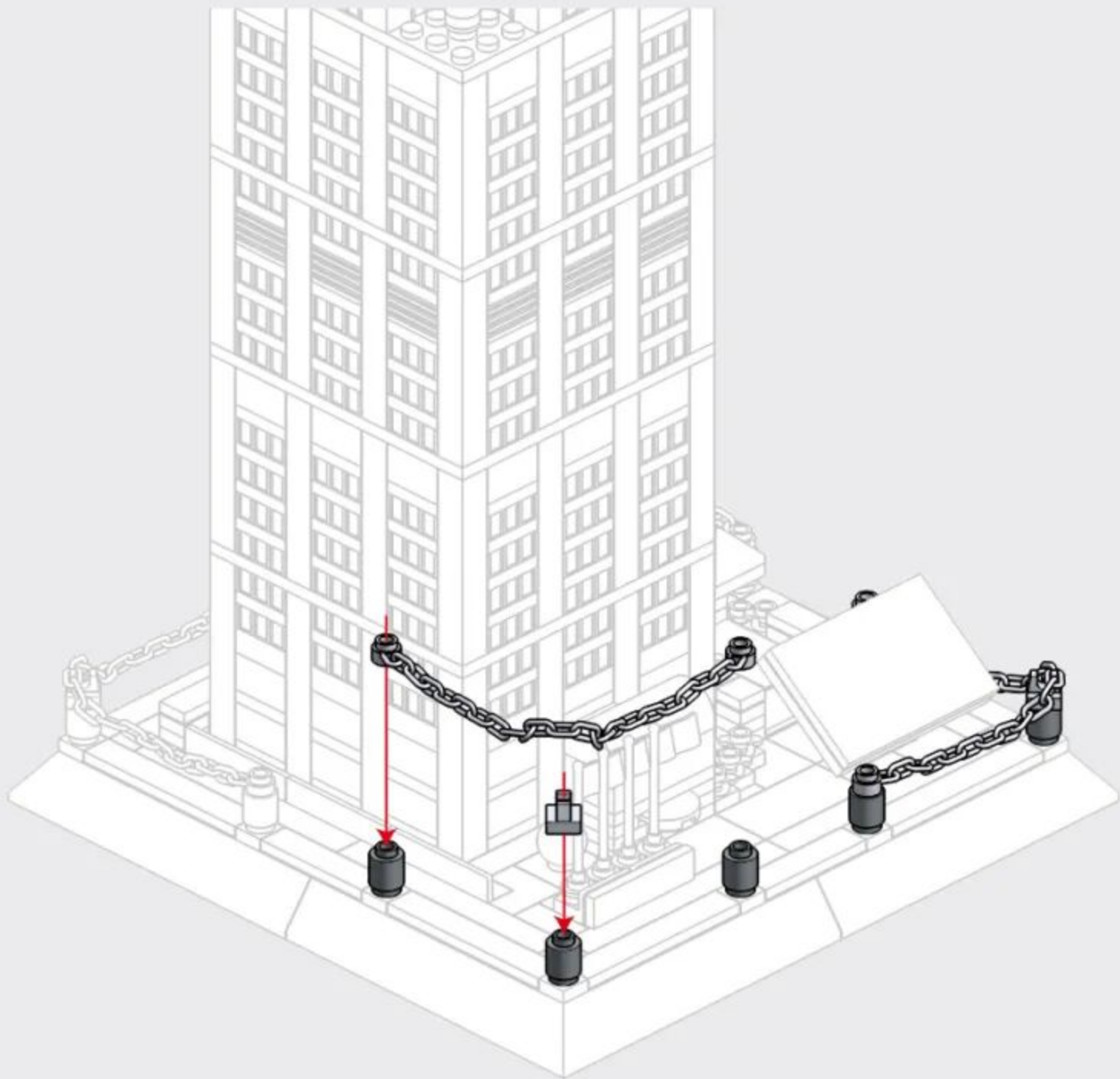
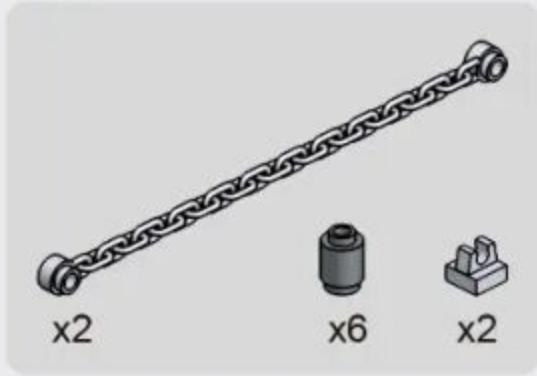

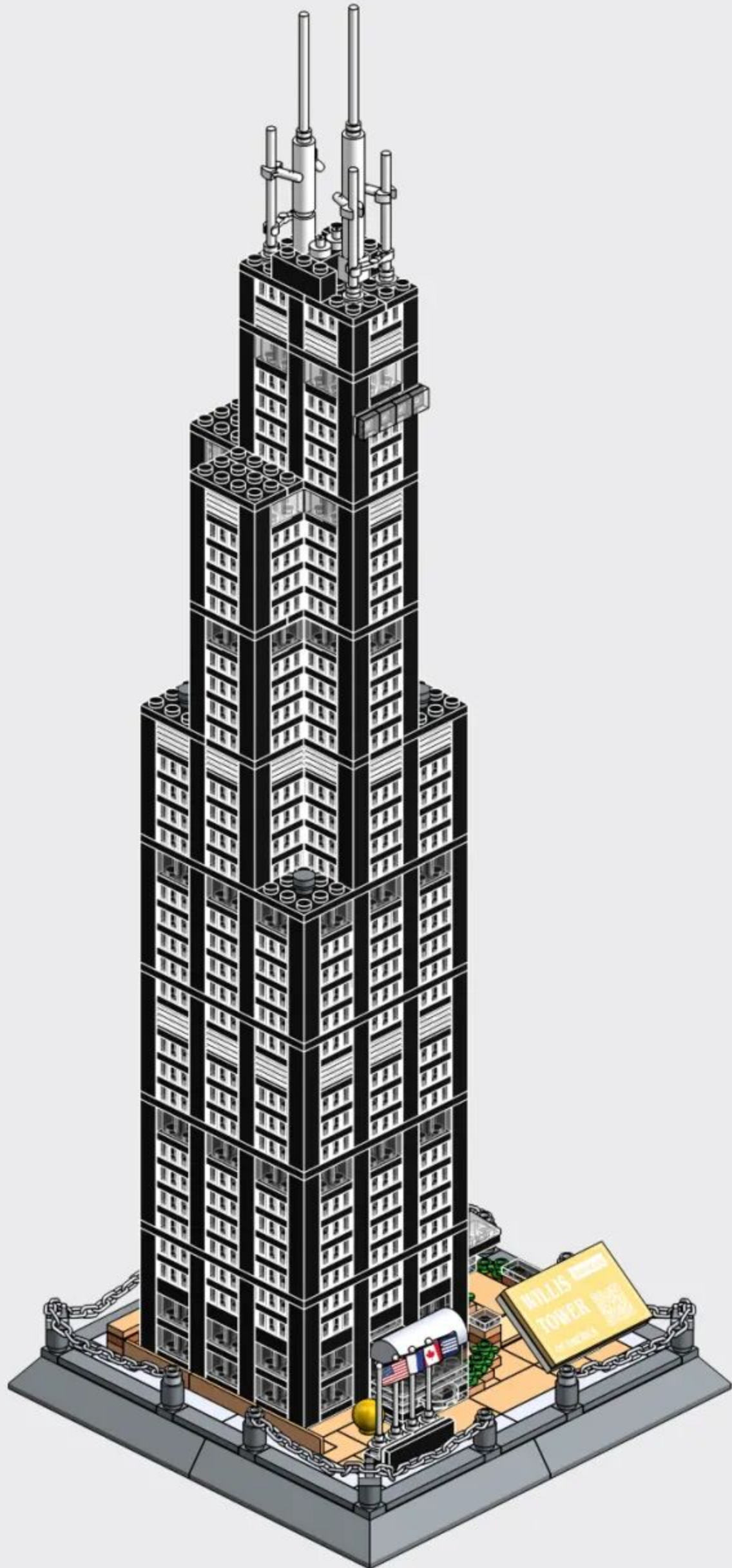

# ARCHITECTURE

The World's great architecture

Shaping Skills   Imagination & Curiosity   Mathematical   Self Discovery & Perception   Parent-Child Interaction   Problem Solving   Creativity



6224 英国伦敦白金汉宫  
BUCKINGHAM PALACE-LONDON,ENGLAND



5225 意大利罗马斗兽场  
COLOSSEUM-ROME,ITALY



5226 日本东京帝国饭店  
IMPERIAL HOTEL-TOKYO,JAPAN



5227 美国纽约自由女神像  
STATUE OF LIBERTY-NEW YORK,AMERICA



6211 德国柏林勃兰登堡门  
BRANDENBURG GATE-BERLIN, GERMANY



6222 中国甘肃长城-嘉峪关  
JIAYU PASS-GANSU,CHINA



6212 日本京都清水寺仁王门  
NIOMON GATE OF KIYOMIZU-DERA-KYOTO,JAPAN



6213 俄罗斯莫斯科瓦西里大教堂  
SAINT BASIL'S CATHEDRAL-MOSCOW,RUSSIA



6214 中国武汉黄鹤楼  
YELLOW CRANE TOWER-WUHAN,CHINA



6215 英国伦敦眼  
LONDON EYE-LONDON,ENGLAND



6221 中国北京故宫-太和殿  
HALL OF SUPREME HARMONY-BEIJING,CHINA



6220 沙特阿拉伯麦加大清真寺  
GREAT MOSQUE OF MECCA,SAUDI ARABIA



6219 美国纽约联合国大厦  
UNITED NATIONS HEADQUARTERS-NEW YORK,AMERICA



4214 美国华盛顿白宫  
WHITE HOUSE-WASHINGTON D.C.,AMERICA



4212 意大利罗马许愿池  
TREVII FOUNTAIN-ROME,ITALY



4213 法国巴黎卢浮宫  
MUSÉE DU LOUVRE-PARIS,FRANCE



4218 新加坡-鱼尾狮  
MERLION,SINGAPORE



4219 英国伦敦双子塔桥  
TOWER BRIDGE-LONDON,ENGLAND



4216 美国华盛顿林肯纪念馆  
LINCOLN MEMORIAL-WASHINGTON D.C.,AMERICA



4217 新加坡-金沙酒店  
MARINA BAY SANDS,SINGAPORE



4210 埃及开罗吉萨金字塔  
GREAT PYRAMID OF GIZA-CAIRO,EGYPT



4221 加拿大渥太华国会山庄  
PARLIAMENT BUILDINGS-OTTAWA,CANADA



4211 英国伦敦伊丽莎白塔  
ELIZABETH TOWER-ENGLAND



4215 加拿大多伦多电视塔  
THE CN TOWER-CANADA



4220 美国纽约熨斗大厦  
FLATIRON BUILDING-NEW YORK,AMERICA



**4222** 阿联酋迪拜哈利法塔 THE BURJ KHALIFA TOWER-DUBAI,UAE **5224** 中国上海东方明珠广播电视塔 ORIENTAL PEARL TOWER-SHANGHAI,CHINA **5212** 美国纽约帝国大厦 EMPIRE STATE BUILDING-NEW YORK,AMERICA **5213** 马来西亚吉隆坡石油双塔 PETRONAS TWIN TOWERS-KUALA LUMPUR,MALAYSIA **5214** 意大利托斯卡纳比萨斜塔 LEANING TOWER OF PISA-TUSCANY,ITALY **5216** 英国伦敦伊丽莎白白塔 ELIZABETH TOWER-LONDON,ENGLAND



**5219** 俄罗斯莫斯科克里姆林宫钟楼 SPASSKAYA TOWER-MOSCOW,RUSSIA **5220** 阿联酋迪拜卓美亚帆船酒店 BURJ AL ARAB HOTEL-DUBAI,UAE **5217** 法国巴黎埃菲尔铁塔 EIFFEL TOWER-PARIS,FRANCE **5221** 中国台北101大楼 TAIPEI 101-TAIPEI,CHINA **6223** 中国武汉长江大桥 WUHAN YANGTZE RIVER BRIDGE



**5210** 法国巴黎圣母院大教堂 CATHÉDRALE NOTRE DAME DE PARIS-PARIS,FRANCE **5211** 印度阿格拉泰姬陵 TAJ MAHAL-AGRA,INDIA **5223** 法国巴黎凯旋门 ARC DE TRIOMPHE-PARIS,FRANCE **5215** 英国伦敦双子塔桥 TOWER BRIDGE-LONDON,ENGLAND **5222** 中国北京天坛祈年殿 HALL OF PRAYER FOR GOOD HARVESTS-BEIJING,CHINA



**6210** 美国旧金山金门大桥 GOLDEN GATE BRIDGE-SAN FRANCISCO,AMERICA **6216** 中国北京万里长城(八达岭) THE GREAT WALL-BEIJING,CHINA **5218** 中国北京天安门 TIAN'ANMEN TOWER-BEIJING,CHINA **6217** 中国西藏布达拉宫 POTALA PALACE-TIBET,CHINA **6218** 芬兰罗瓦涅米圣诞老人办公室 SANTA CLAUS OFFICE-ROVANIEMI,FINLAND



# THE WILLIS TOWER

COUNTRY: America  
CITY: Chicago, Illinois



America  
The world's great architecture

