



AIWAN TING PAVILION

湖南长沙爱晚亭

Hunan, Changsha

The world's great architecture



Creative
Ability



Family
Interaction



Observation
Ability



Thinking
Ability



Practical
Ability



6+ / 5230 / 987PCS
Suitable Age Product Number Parts Total

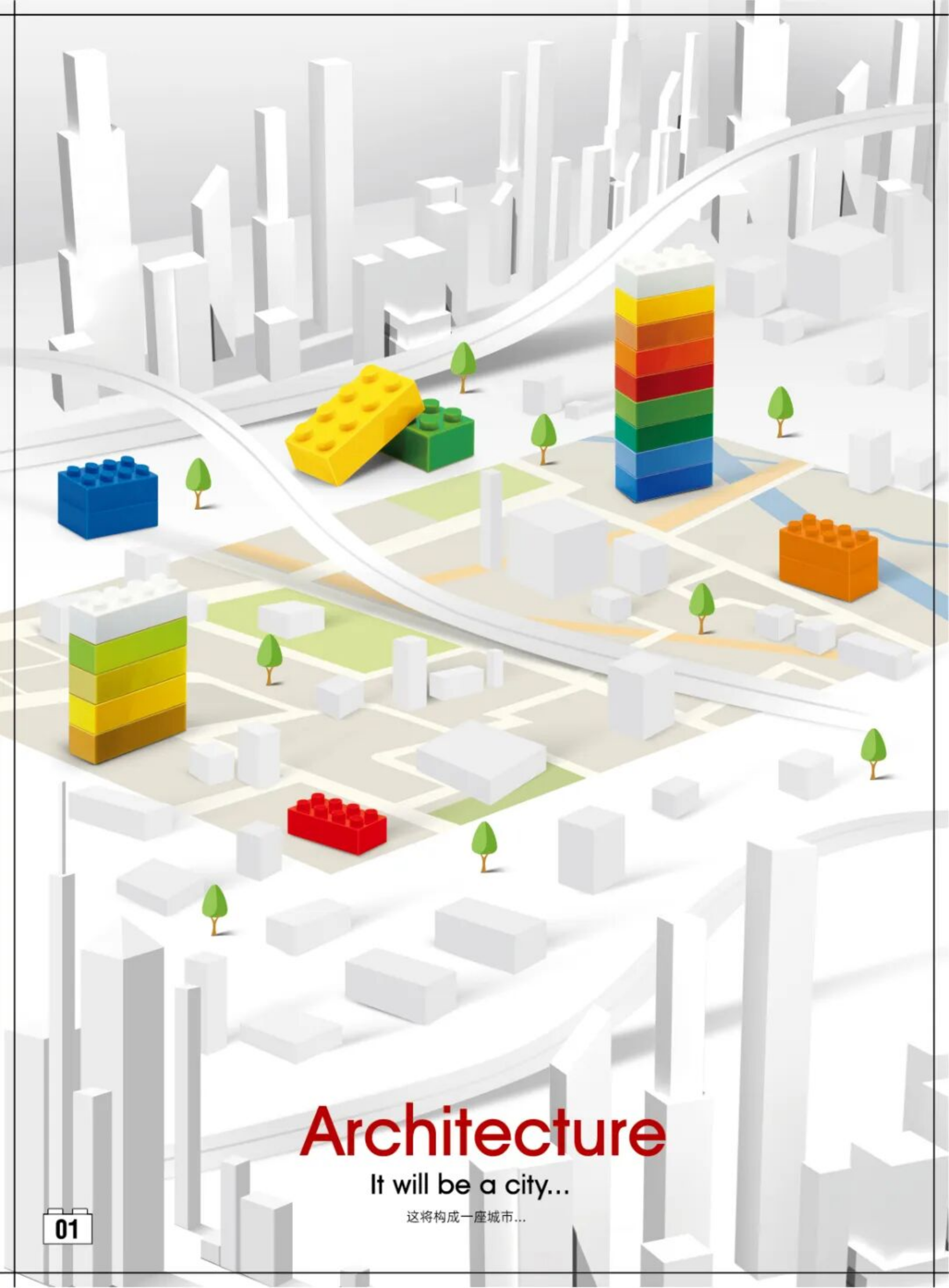

Architecture

It will be a city...

这将构成一座城市...

ABOUT THE PRODUCT

关于产品



ARCHITECTURE

WANGE The world's great architect since 1991

Aiwan Ting Pavilion

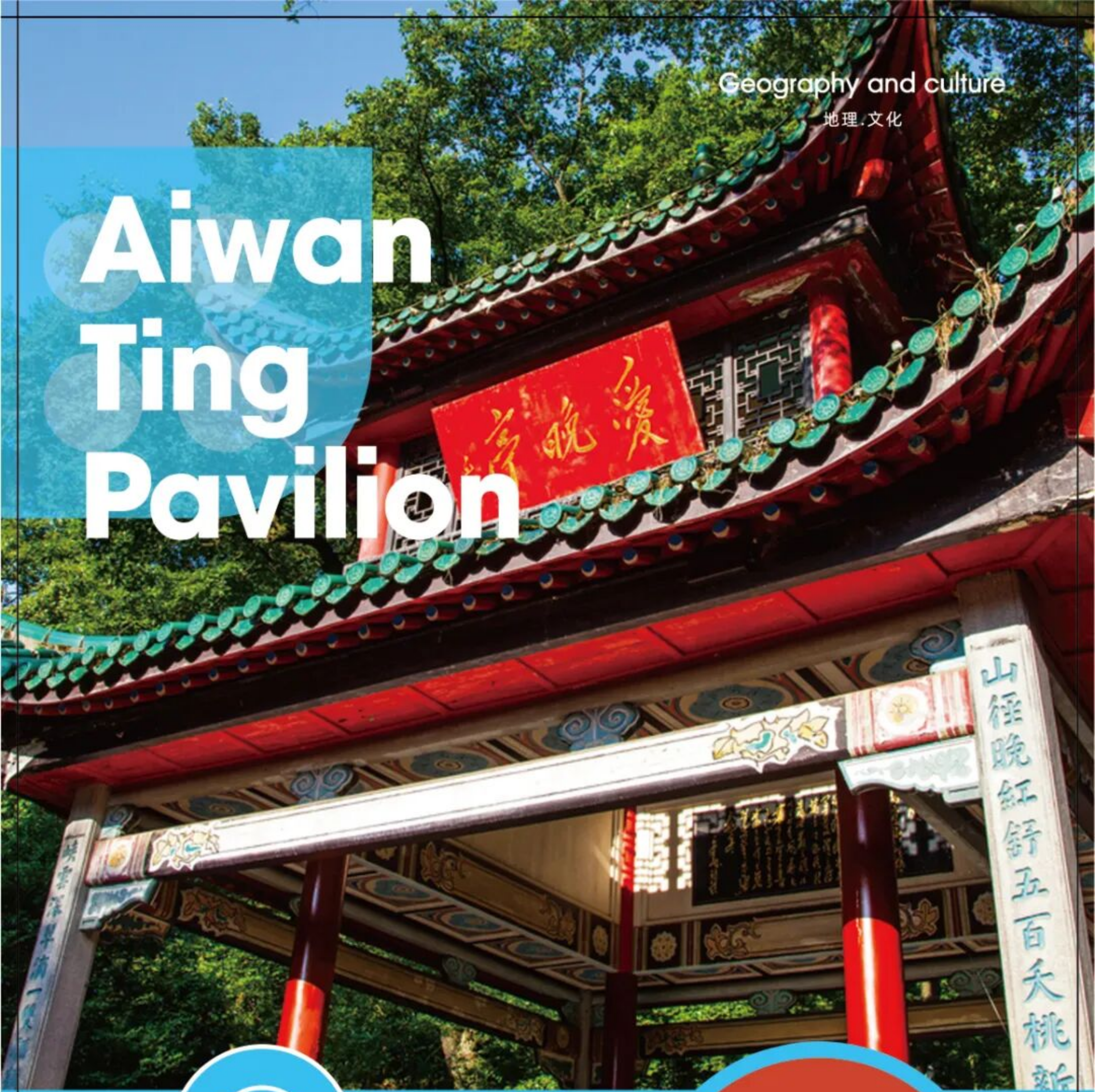

Aiwan Pavilion, located in Changsha, Hunan Province, China

Aiwan Ting Pavilion



Geography and culture

地理.文化



Aiwan Pavilion, located in Changsha City, Hunan Province. One of the classics of Chinese pavilion architecture





爱晚亭

Aiwan Ting ■ Pavilion

China

The contents of this chapter refer to the Wikipedia website.

本章内容参考维基百科网站，更多资讯可自行查阅。

The world's great architecture

Buildings and layout

■ 建筑物和布局



Seated in Qingfeng Gorge (Cool Breeze Gorge) at the foot of Yuelu Hill, the Aiwan Pavilion, or the Love Dusk Pavilion sits west to east and is embraced on three sides by green hills. Originally built in 1792 during Qing Dynasty (1644-1911) by the director of Yuelu Academy, Love Dusk Pavilion is considered the Four Most Famous Pavilions of China together with Zuiweng Pavilion in Anhui Province, Huxin Pavilion in the middle of the West Lake in Hangzhou and Taoran Pavilion in Beijing.

爱晚亭占地 50 平方米，边长 6.23 米，台基高 0.4 米，总高 12 米。内金柱为圆木丹漆，外檐柱为四根，由整块方形花岗石加工而成。亭顶有四重悬檐，尖宝顶。四个翅膀和角落被拉伸和凸起，并覆盖着绿色琉璃管瓦。亭内有一块横匾，上面刻有名人亲笔的“沁园春长沙”四字。朱红色鎏金“情夜亭”匾额



Symbolism

Well-known for a famous poem by the famed poet Du Mu (803-852) of Tang Dynasty (618-907), from which the name of the pavilion came, the Love Dusk Pavilion was also a holy land of revolution and one of the favorite sites of some celebrities in their early years. When they studied in Changsha, well-known persons usually came to Yuelu Academy and Love Dusk Pavilion with his classmates for free talking and discussing on politics.

爱晚亭古朴典雅，亭坐西向东，三面环山。爱晚亭内为丹漆圆柱，外檐四石柱为花岗岩，加之配以东西两面亭榭所悬的红底鎏金“爱晚亭”匾额，令亭子有现代意味，整体上保留了较多清代亭台楼阁建筑的风格。匾额是由名人所书手迹刻制的，由当时的湖南大学校长李达专函请得。

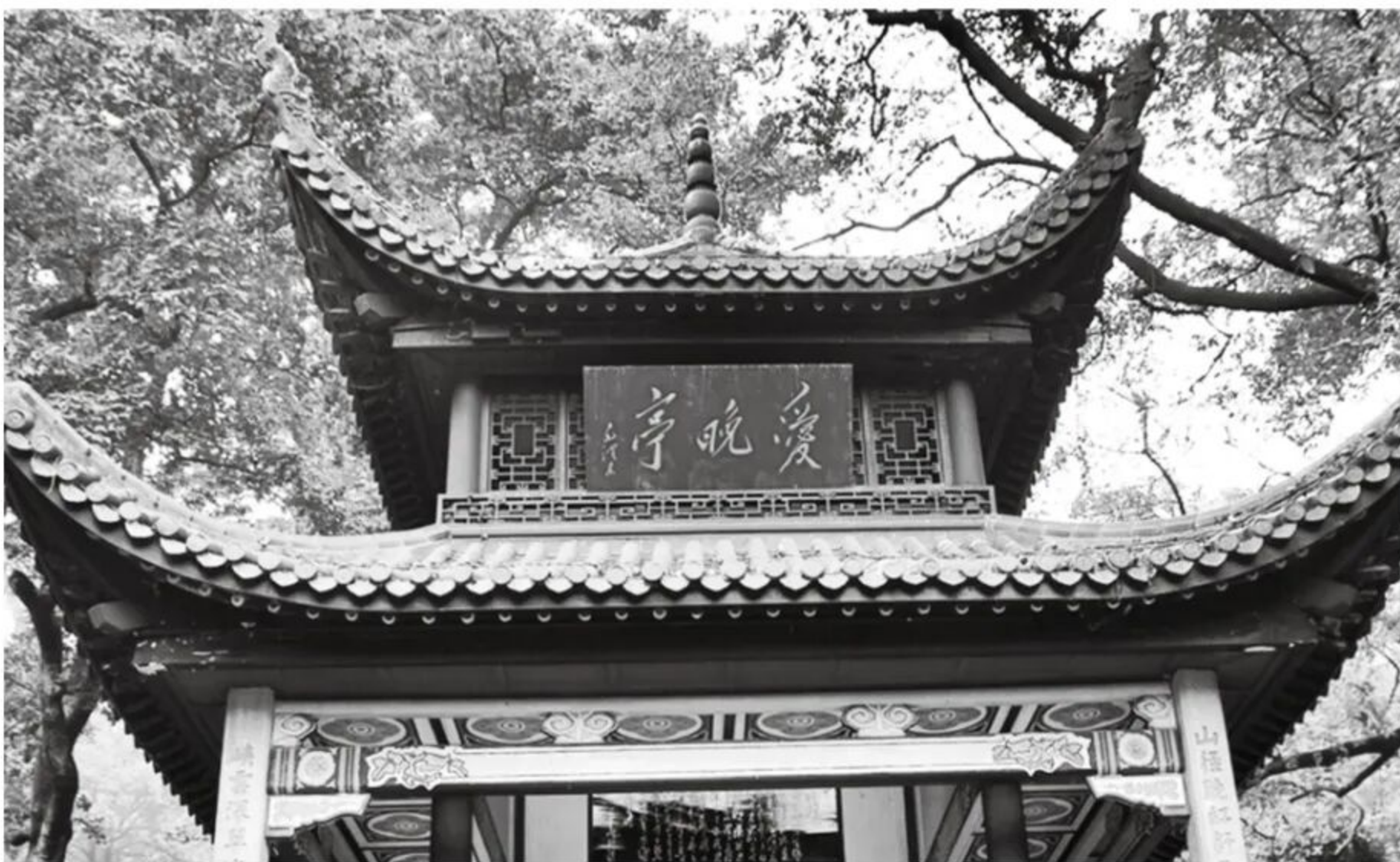

Design and construction

Destroyed during the Anti-Japanese War (1937-1945), the Aiwan Pavilion was rebuilt in 1952 and repaired in 1987. It is a green-tile-covered pavilion with 8 columns and multiple eaves. Inside are four granite pillars, painted caisson, and a horizontal tablet on which is the name of the pavilion, which was carved according to the handwriting of a public figure. Furthermore, the stele erected in the pavilion inscribes one verse of a celebrity, which described the magnificence and beauty of Changsha City. In the front of Love Dusk Pavilion, there is a pool with flowing spring; enveloped in maple trees, the pavilion provides a superb beauty in the late autumn with gorgeous red leaves attracting stream of appreciators. surrounding area. Looking far away, all are Fenglin. There is a couplet written by Cheng Songwan on the stone pillar in front of the pavilion: "The mountain trails are red in the evening, five hundred yao peaches are newly planted; the gorges are deep and green, and a pair of cranes are waiting to be caged."

爱晚亭平面呈方形，占地面积50平方米。亭边长6.23米，台基高0.4米，通高12米。爱晚亭内金柱圆木丹漆，由整条方形花岗石加工而成。亭顶重檐四披，攒尖宝顶，四翼角边远伸高翘，覆以绿色琉璃筒瓦。爱晚亭八柱支撑，分上下两层，亭角翘首相望。爱晚亭亭台东西两面的亭榭悬有“爱晚亭”金字红匾。亭形为重檐八柱，琉璃碧瓦，亭角飞翘，远观似凌空欲飞状。爱晚亭亭子东向开阔，只有平地纵横十余丈。街远涵近，紫翠菁葱，流泉不断，熏染陶然。亭前那方池塘，略有亩许，周边桃柳成行。放眼远眺，皆是枫林。亭前石柱上刻有程颂万所撰的对联：“山径晚红舒，五百天桃新种得；峡云深翠滴，一双驯鹤待笼来”。

Creation and thinking

创作·思考

Drawing Design

手绘设计



Shantou Wange Educational Material Sci-Tech Co., Ltd.
©2014 Wange / Dubie. All Rights Reserved

Force Balance

受力平衡

Physical operations

物理运算

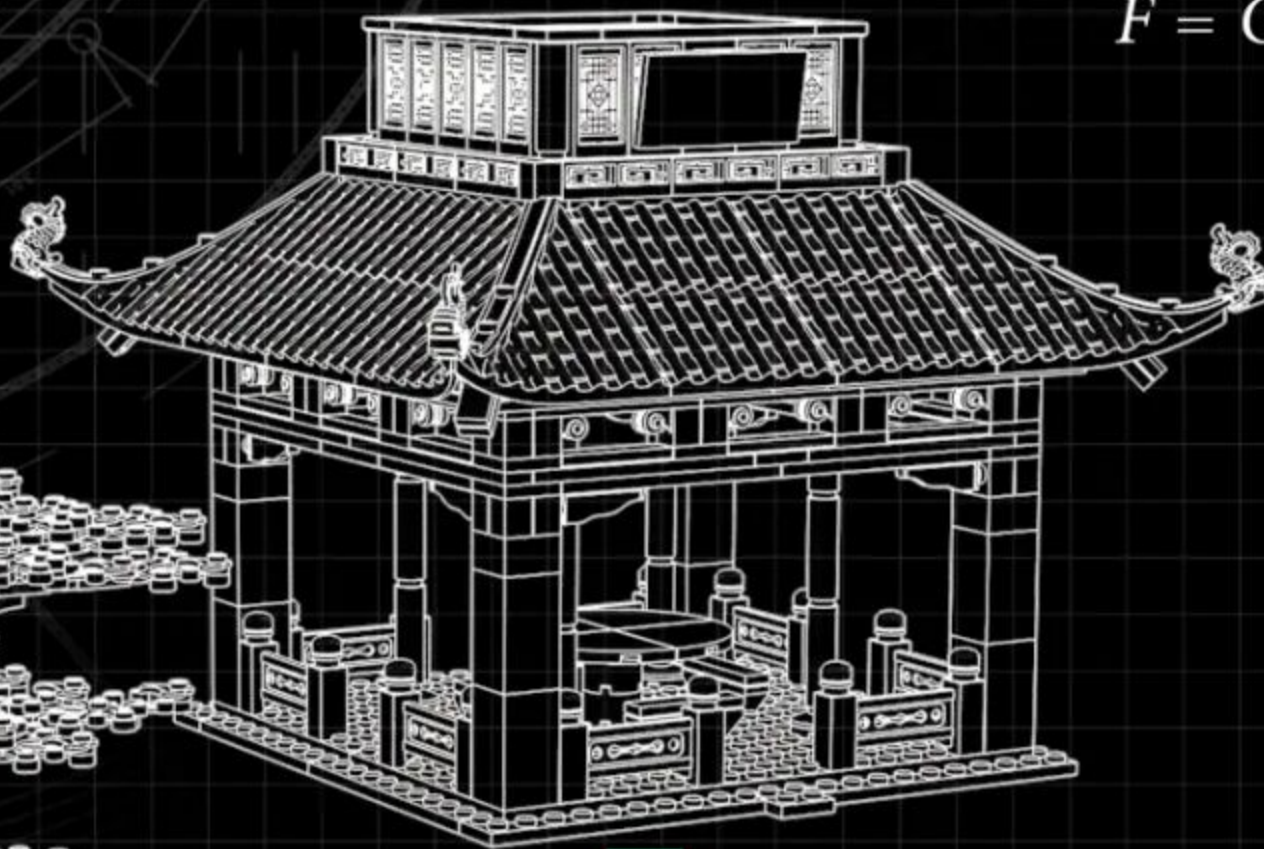
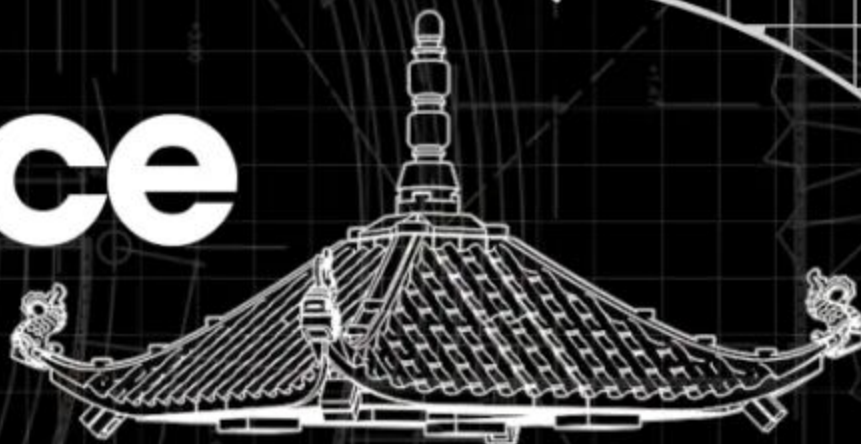

$$F = G \frac{m_1 m_2}{d^2}$$

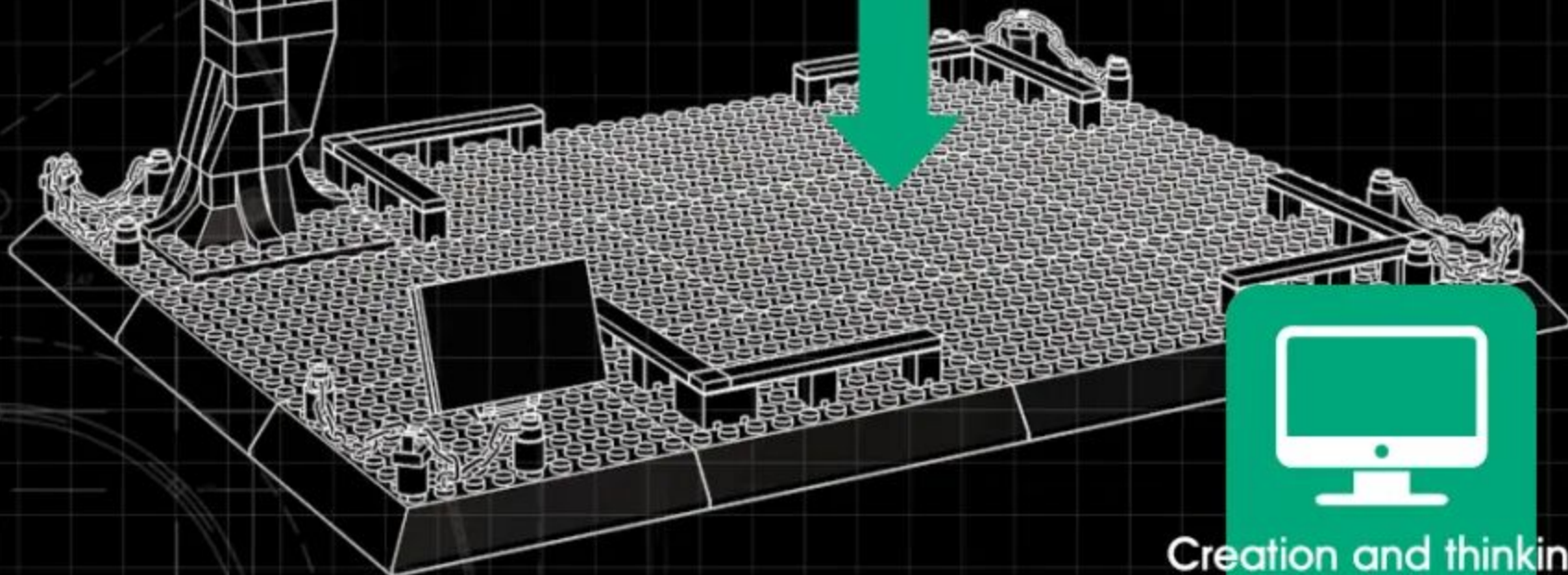

Creation and thinking

创作·思考

Special parts

特殊零件的开发利用

$$S=4\pi \cdot r^2$$

$$a^2+b^2=c^2$$



WG1390
6孔中式栏杆



WG1391
无孔3x6



WG1401
双面矮4孔



WG1389
4孔回纹栏杆



WG1393
3倍雀替



WG1392
鱼龙脊兽

$$\sin^2 a + \cos^2 a = 1$$

features and function

特点.功能

Main Color Matching

配色方案



Color matching Adopting 3 main colors, Dark green, red and Light gray as the main color, the more reasonable and Brown color matching on the original building, making the product more atmospheric and the whole design is more reasonable.

Aiwan Ting Pavilion

爱晚亭



Front

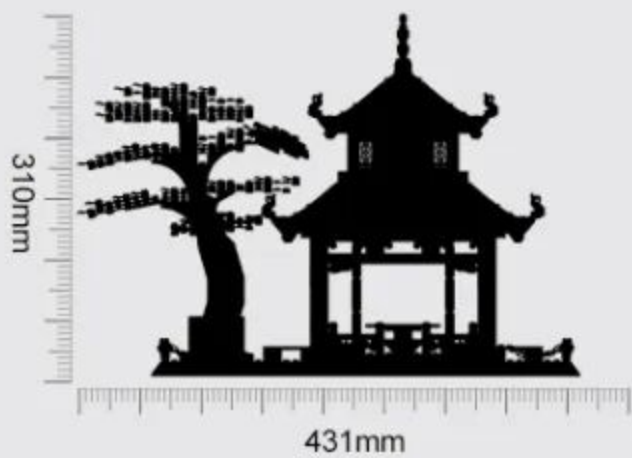

Left

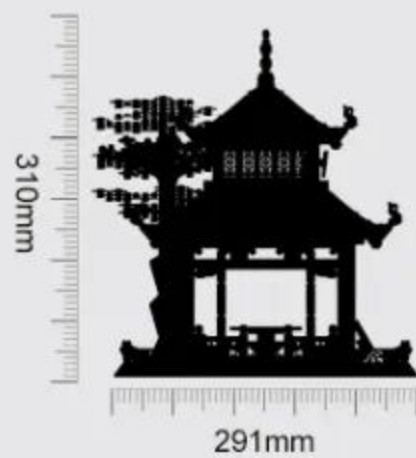

Back

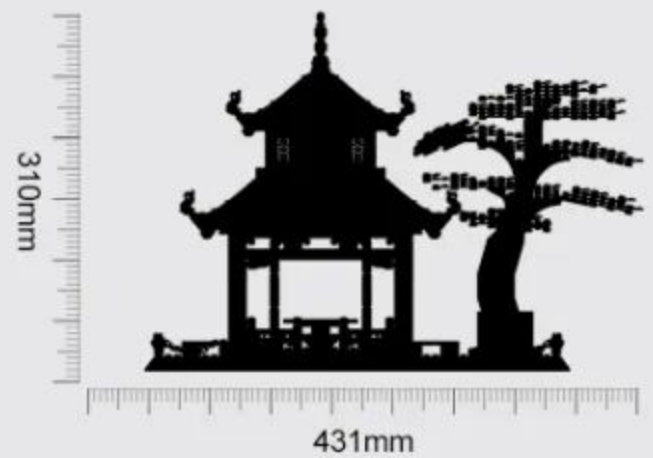

Product Size:431X291X310mm

Creative Ability



Family Interaction



Observation Ability



Thinking Ability



Practical Ability



Instructions For Use

积木起件器使用说明
Brickseparator

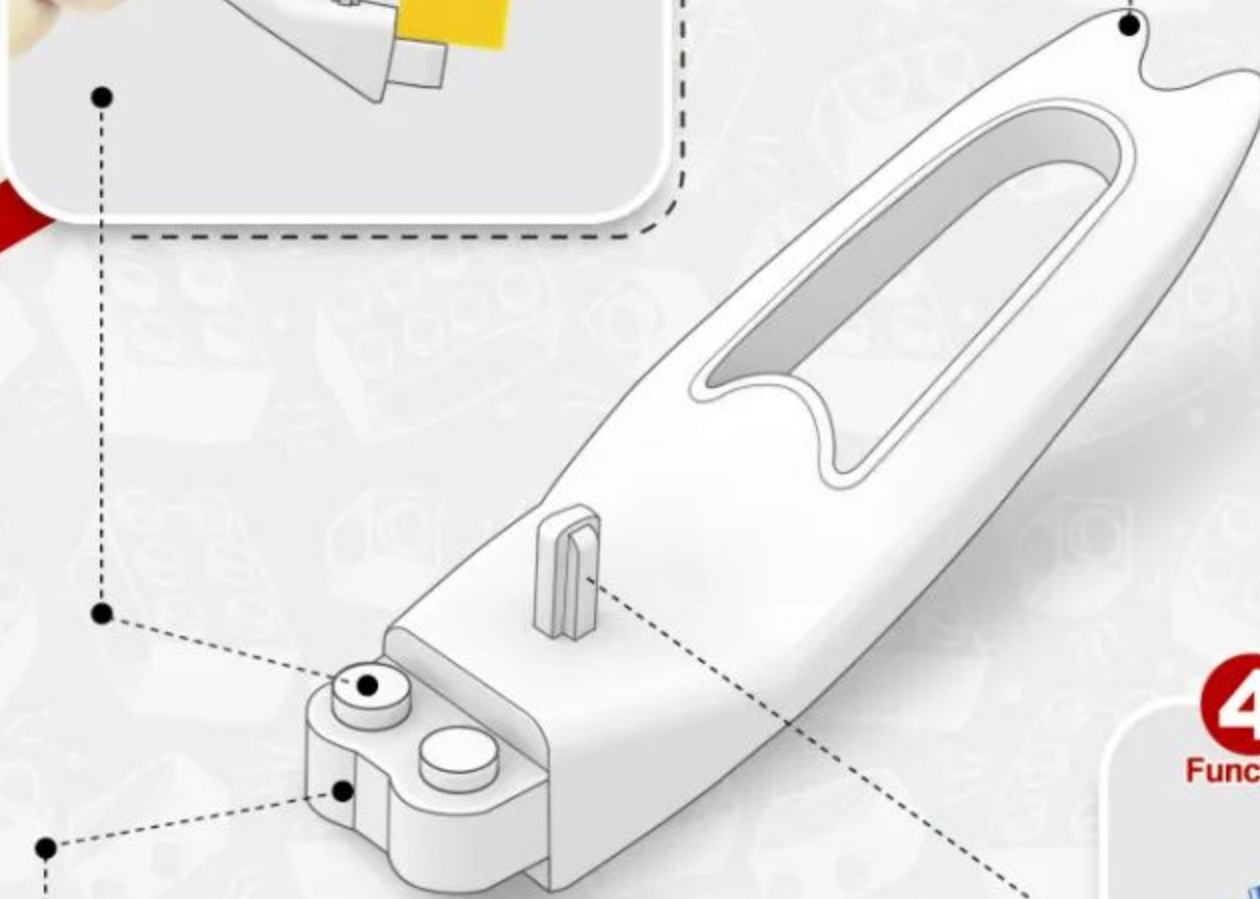
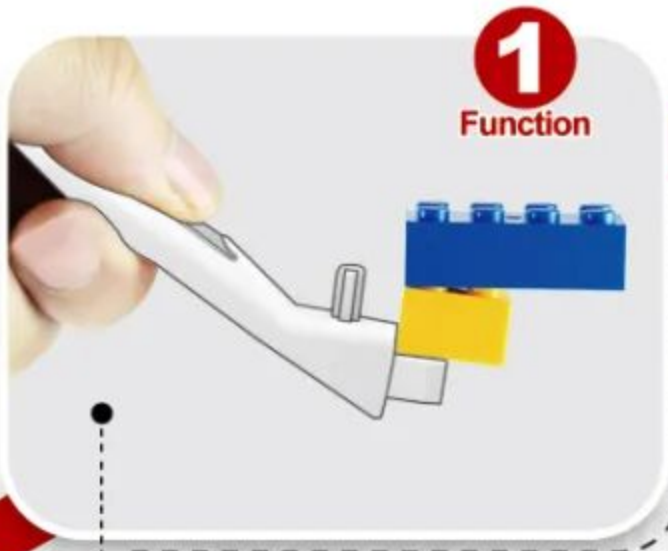

4 ways to make installation easier
让安装更简单

小提示：积木包分为底板包、整版配件包及普通配件包，底板包标识为A/B/C...，普通配件包编码与说明书对应，整版配件包无标识。
 Tip: Building block packs are divided into baseplate packs, runner accessory packs, and standard accessory packs. Baseplate packs are labeled A/B/C..., regular accessory packs have codes that correspond to the instructions, and runner accessory packs have no labels.



- Open the product packaging correctly and classify the building block packs by type.

用正确方式拆解产品外包装,按积木包类型进行分类。



- Confirm the quantity of building block packs and cross-check them with the pack identifiers and the instructions.

确认积木包数量, 对照积木包标识和说明书步骤。



- Open the building block packs according to the pack identifier steps. Sort them in order by type and color for easier assembly.

按积木包标识步骤拆开积木包,按顺序以类型、颜色进行分类以便搭建。



- Assemble your building block model following the steps in the instruction manual.

按说明书步骤拼装并完成你的积木模型。



1:1 Physical Reference Table

十字棒配件1:1尺寸参照表



Instructions For Use

让安装更简单



2 $(1 \times 2) = 2$



3 $(1 \times 3) = 3$



4 $(1 \times 4) = 4$



5 $(1 \times 5) = 5$



6 $(1 \times 6) = 6$



7 $(1 \times 7) = 7$



8 $(1 \times 8) = 8$



9 $(1 \times 9) = 9$



10 $(1 \times 10) = 10$



12 $(1 \times 12) = 12$



16 $(1 \times 16) = 16$



PARTS LIST

配件清单

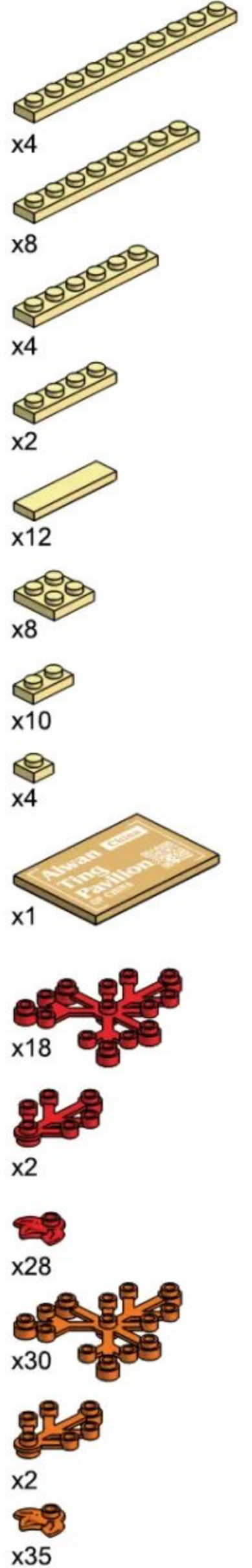
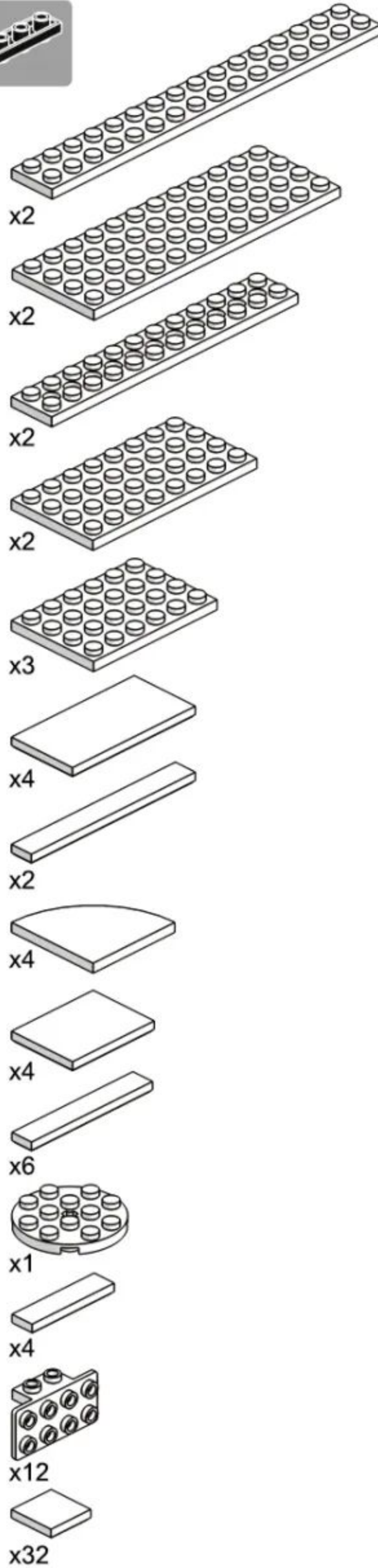
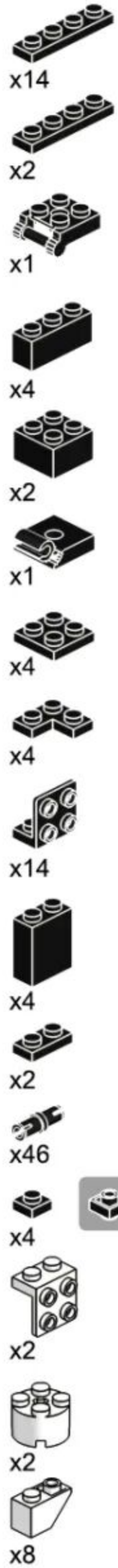
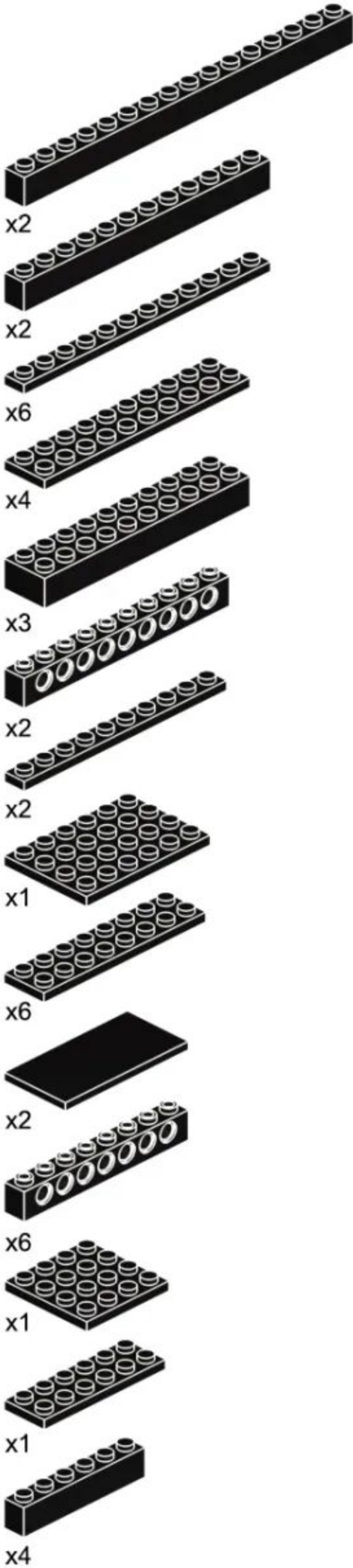

PARTS LIST

配件清单

	x2		x4		x1		x1		x4
	x2		x24		x2		x4		x4
	x8		x8		x6		x1		x8
	x2		x4		x4		x1		x3
	x4		x2		x2		x1		x6
	x16		x3		x8		x1		x1
	x1		x4		x2		x3		x3
	x8		x1		x8		x5		x2
	x8		x2		x2		x1		x1
	x8		x6		x1		x1		x1
	x8		x4		x4		x2		x2
	x8		x8		x4		x2		x2
	x1		x4		x20		x1		x2
	x2		x20		x4		x4		x6
	x1		x4		x4		x4		x2
	x1		x8		x4		x4		x2

产品有增补件请以实物为准

If product has additional parts, please in kind prevail.



271PCS

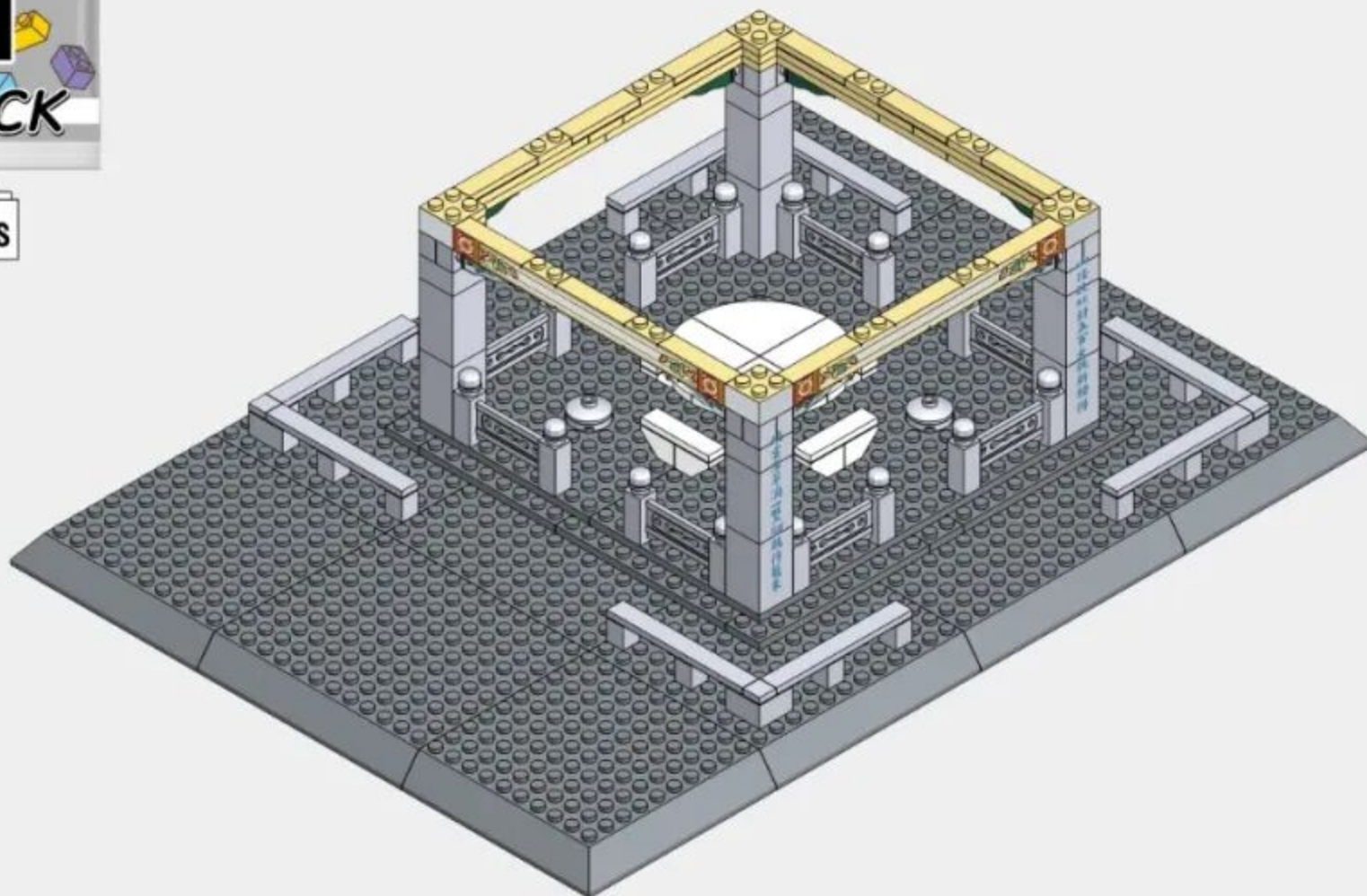

1-1

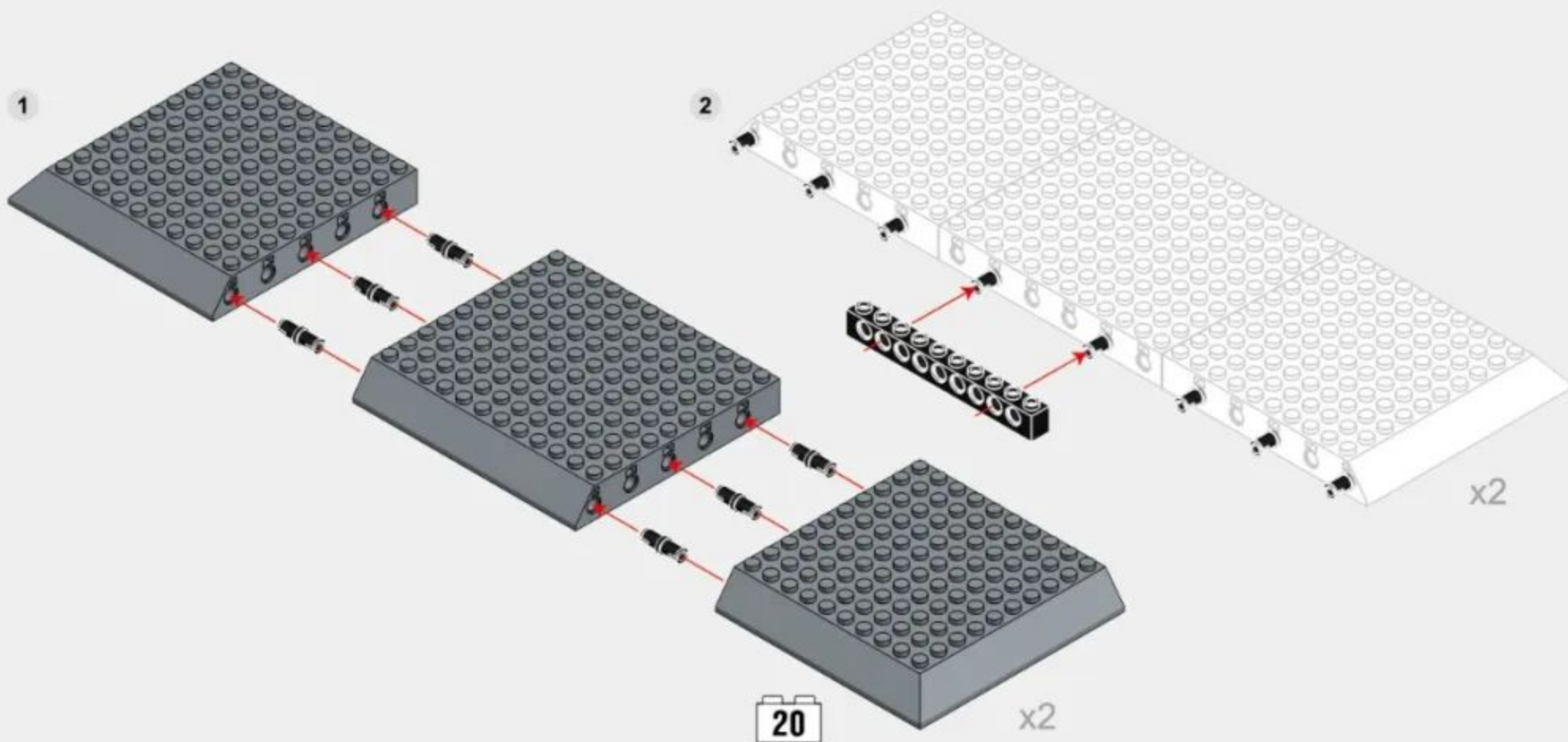
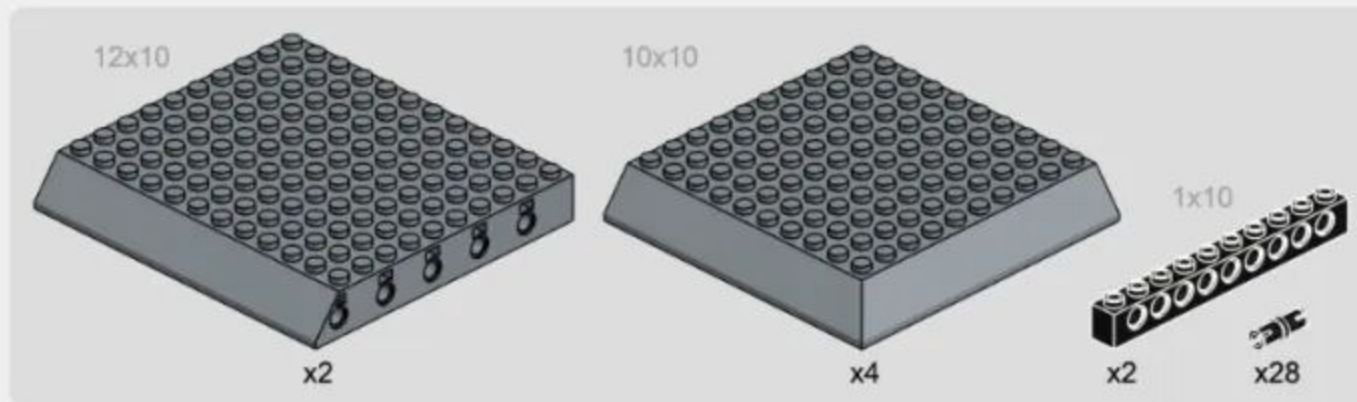

1-2

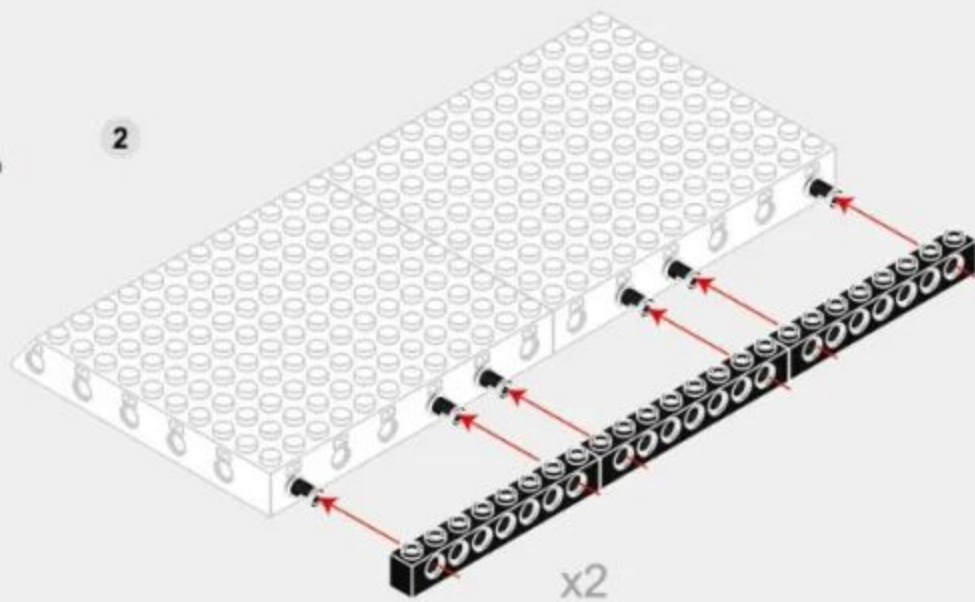
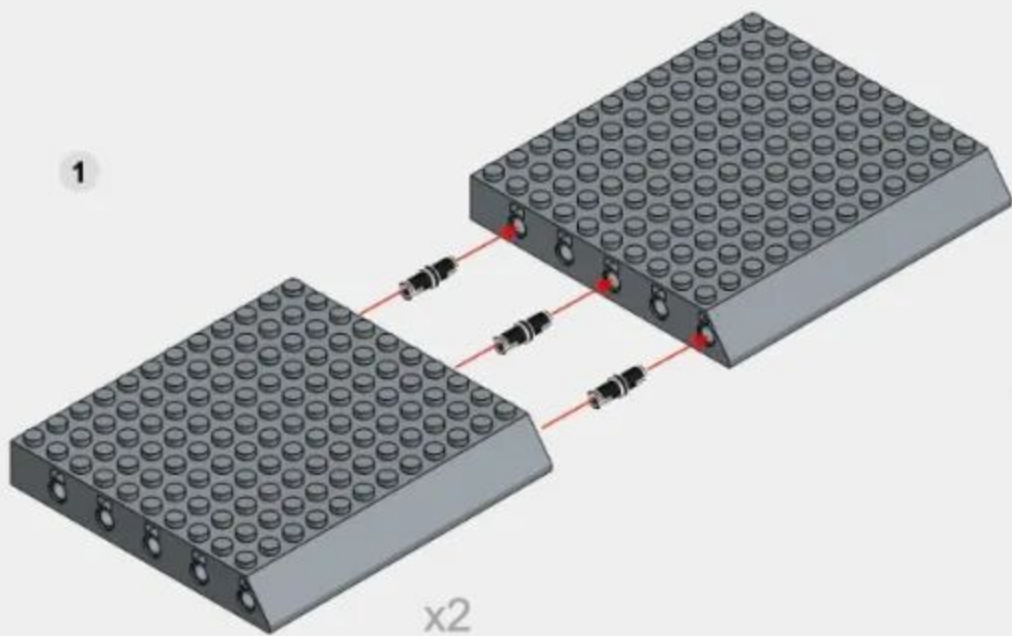
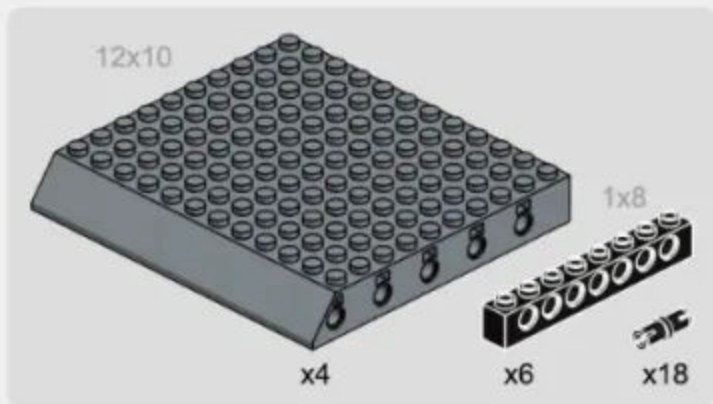

1-3

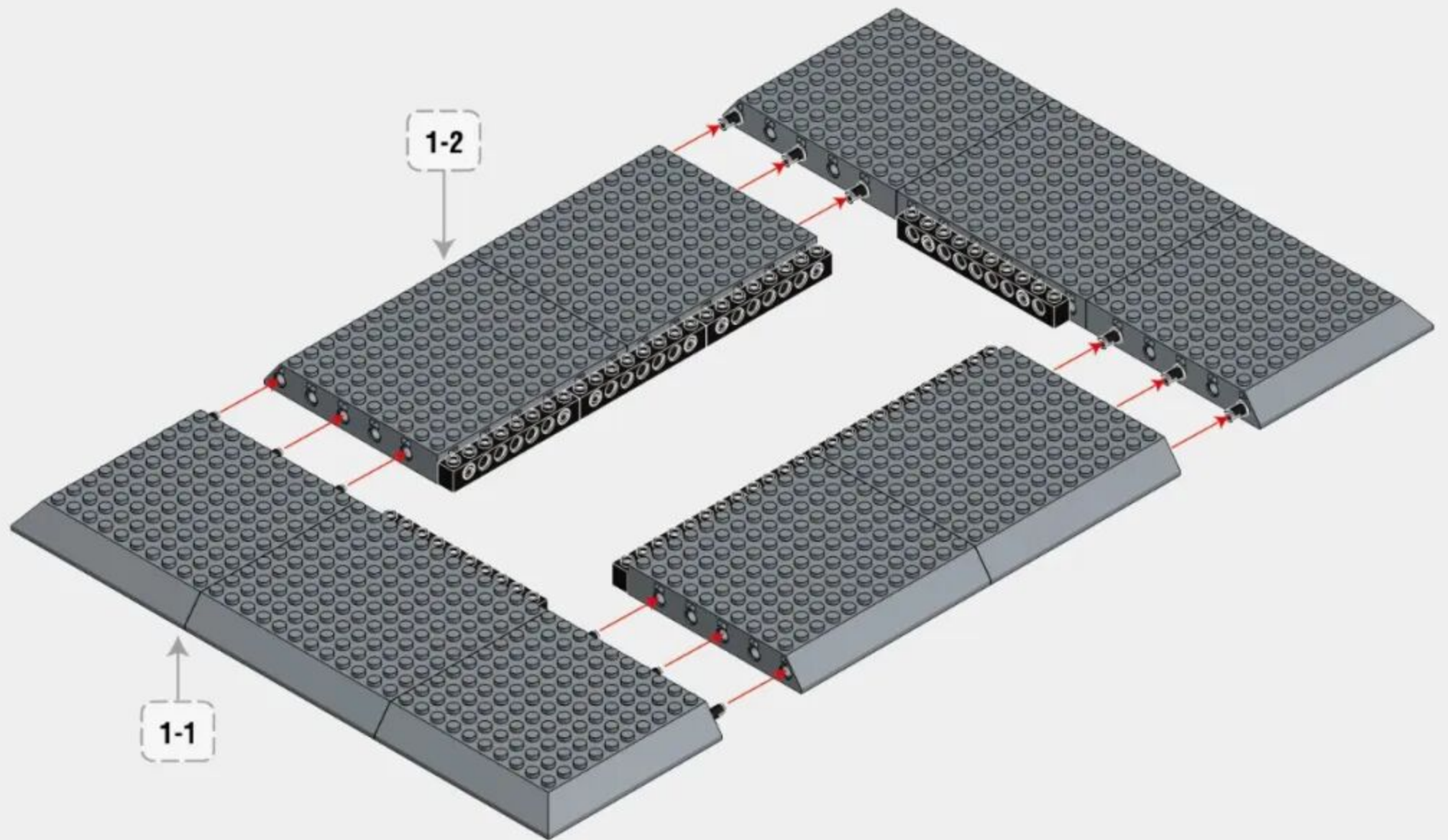

1-4

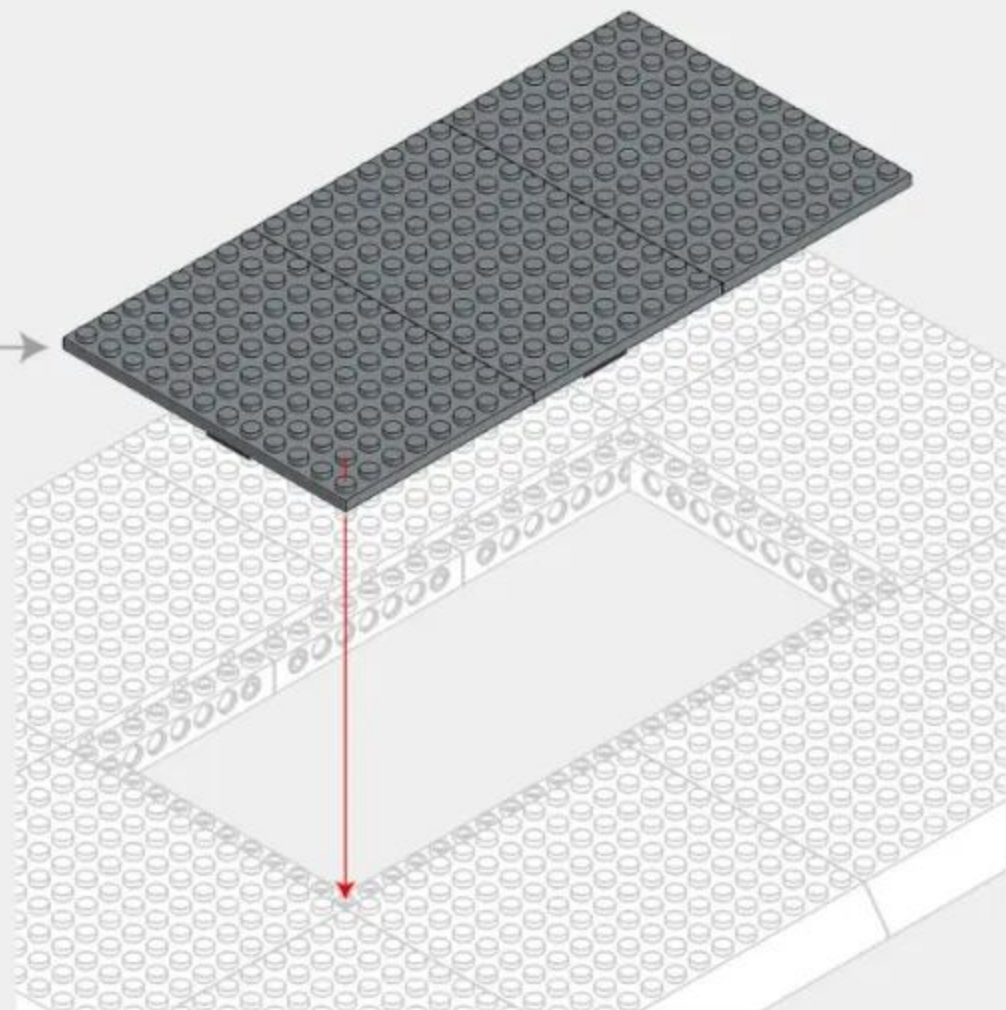
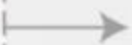
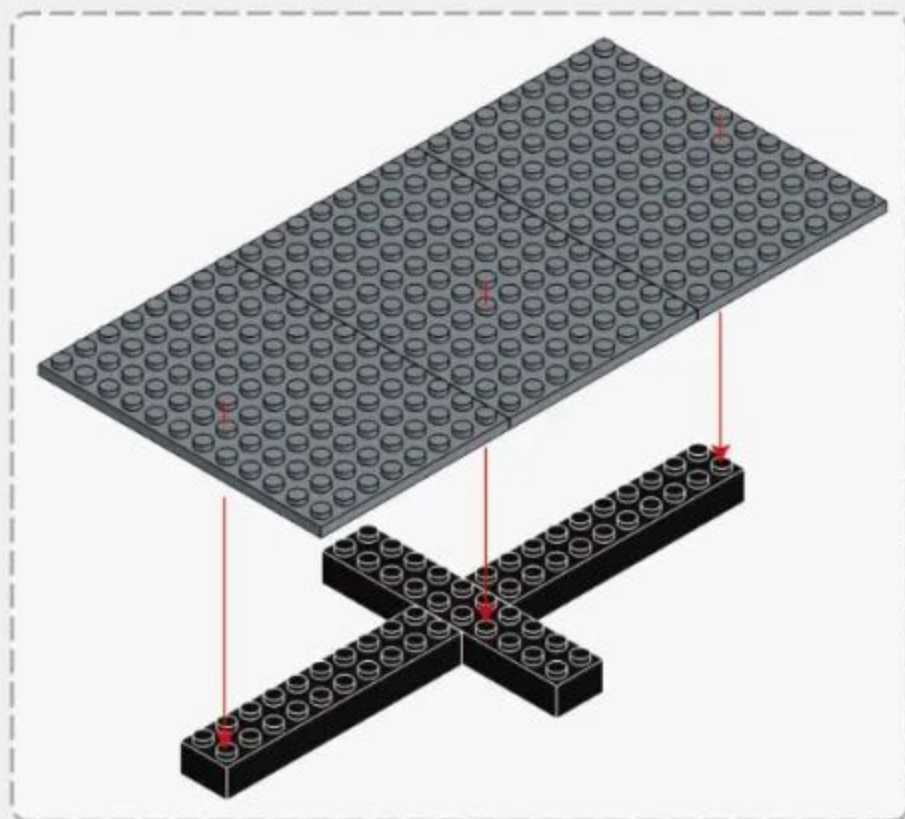
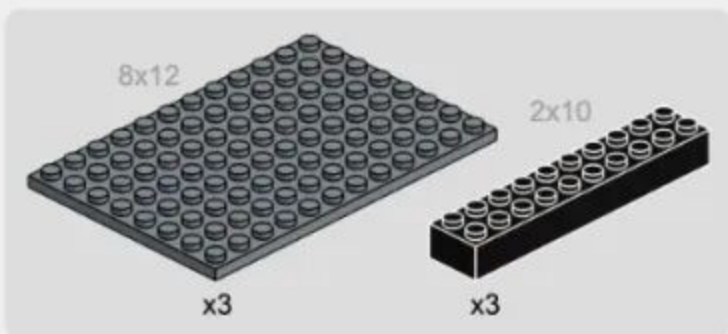

1-5

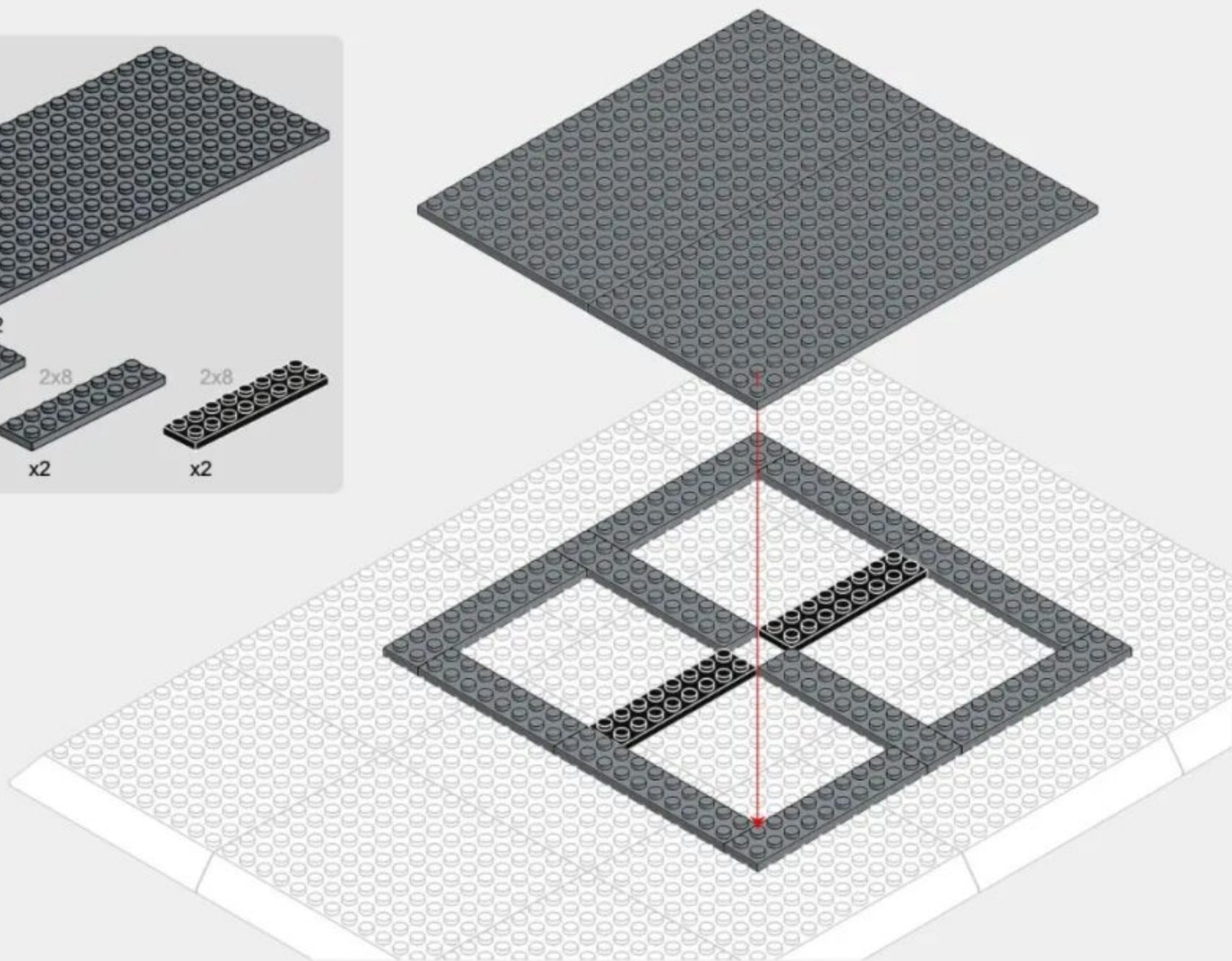
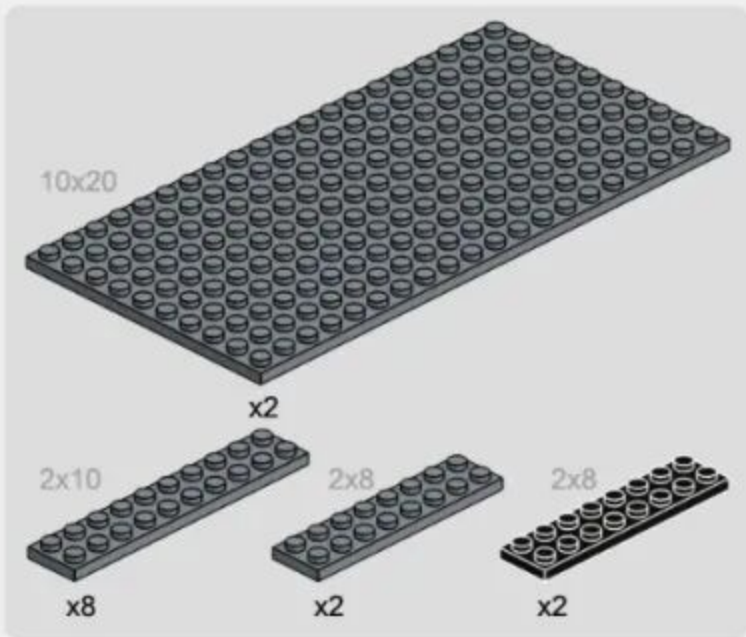

1-6



x4



x16



x4

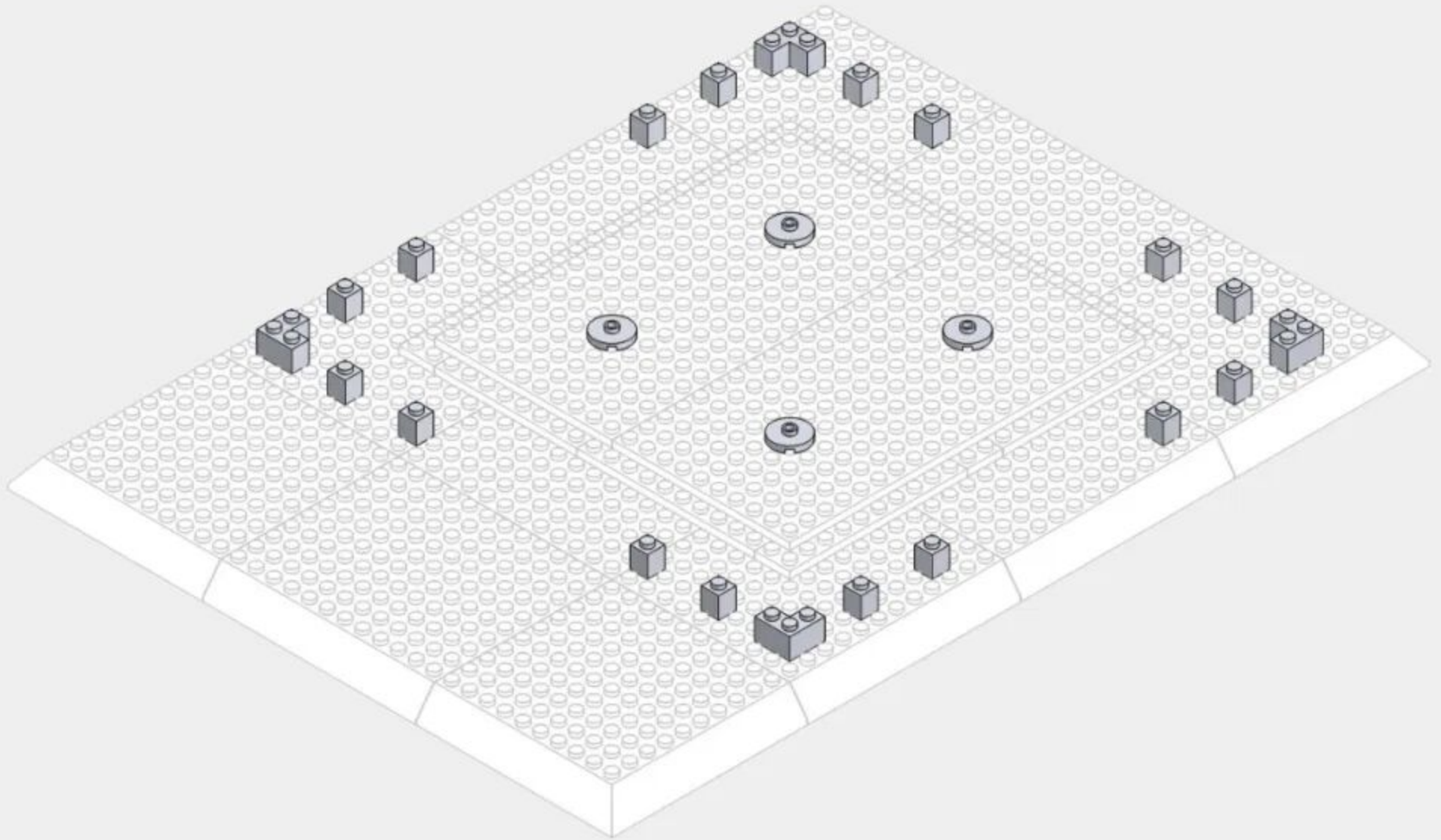

1-7

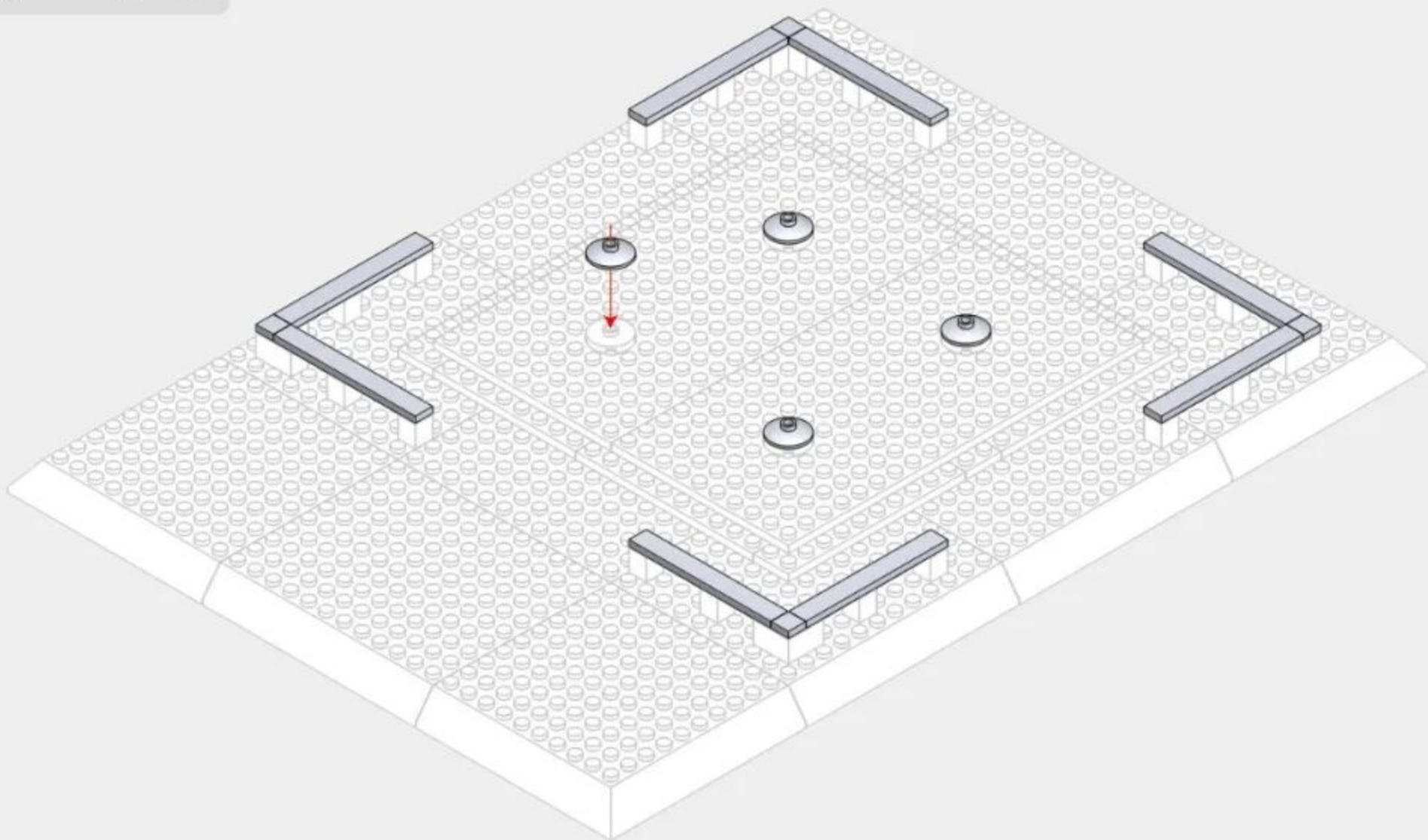
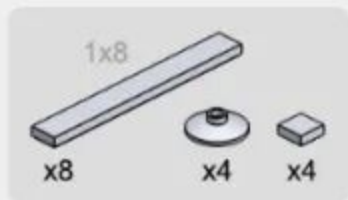

1-8

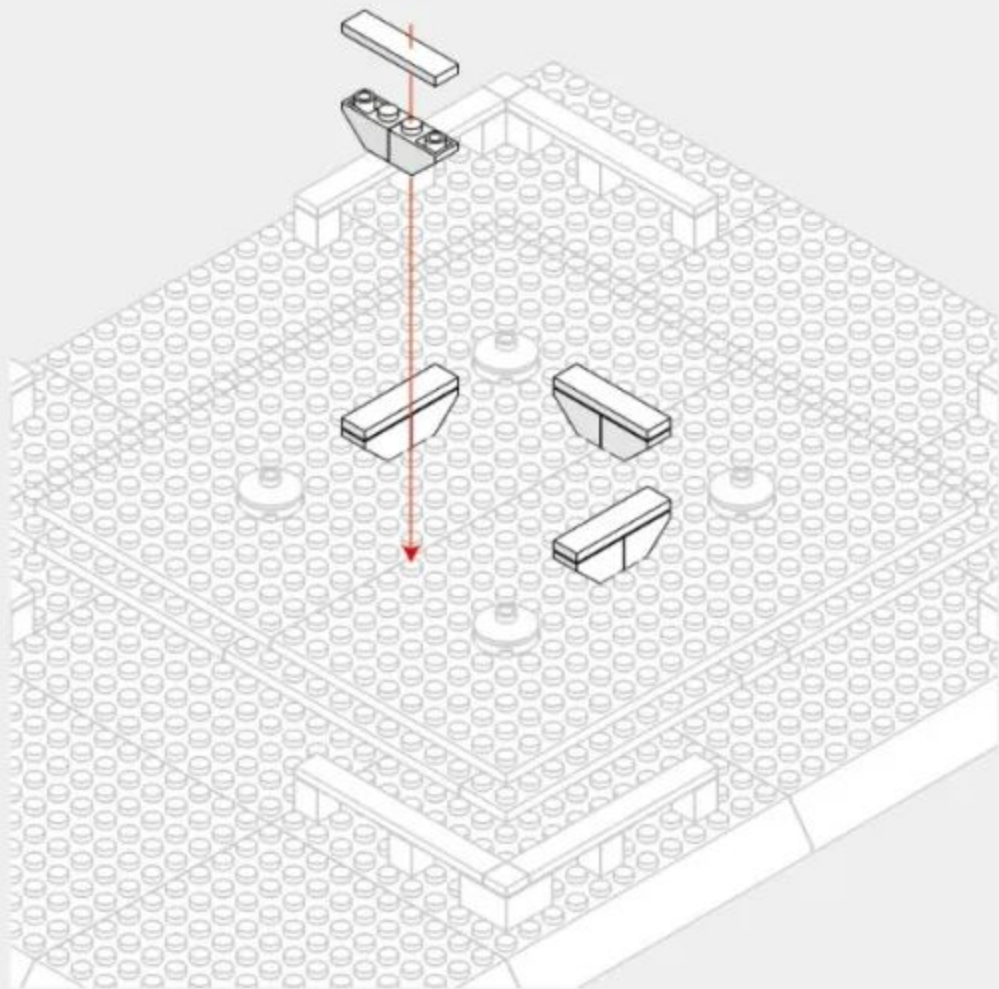
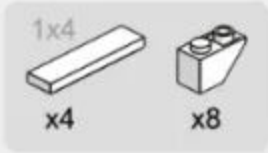

1-9

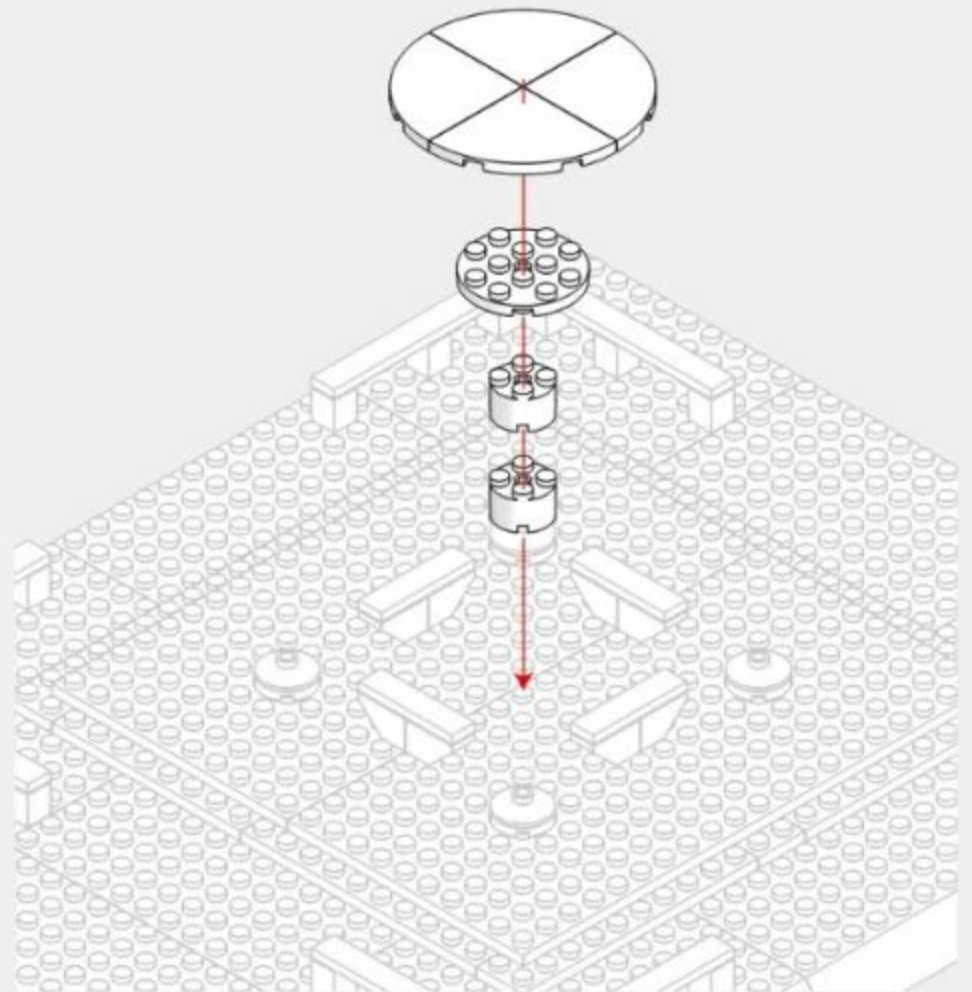
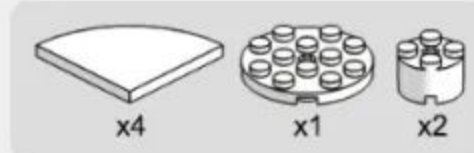

1-10

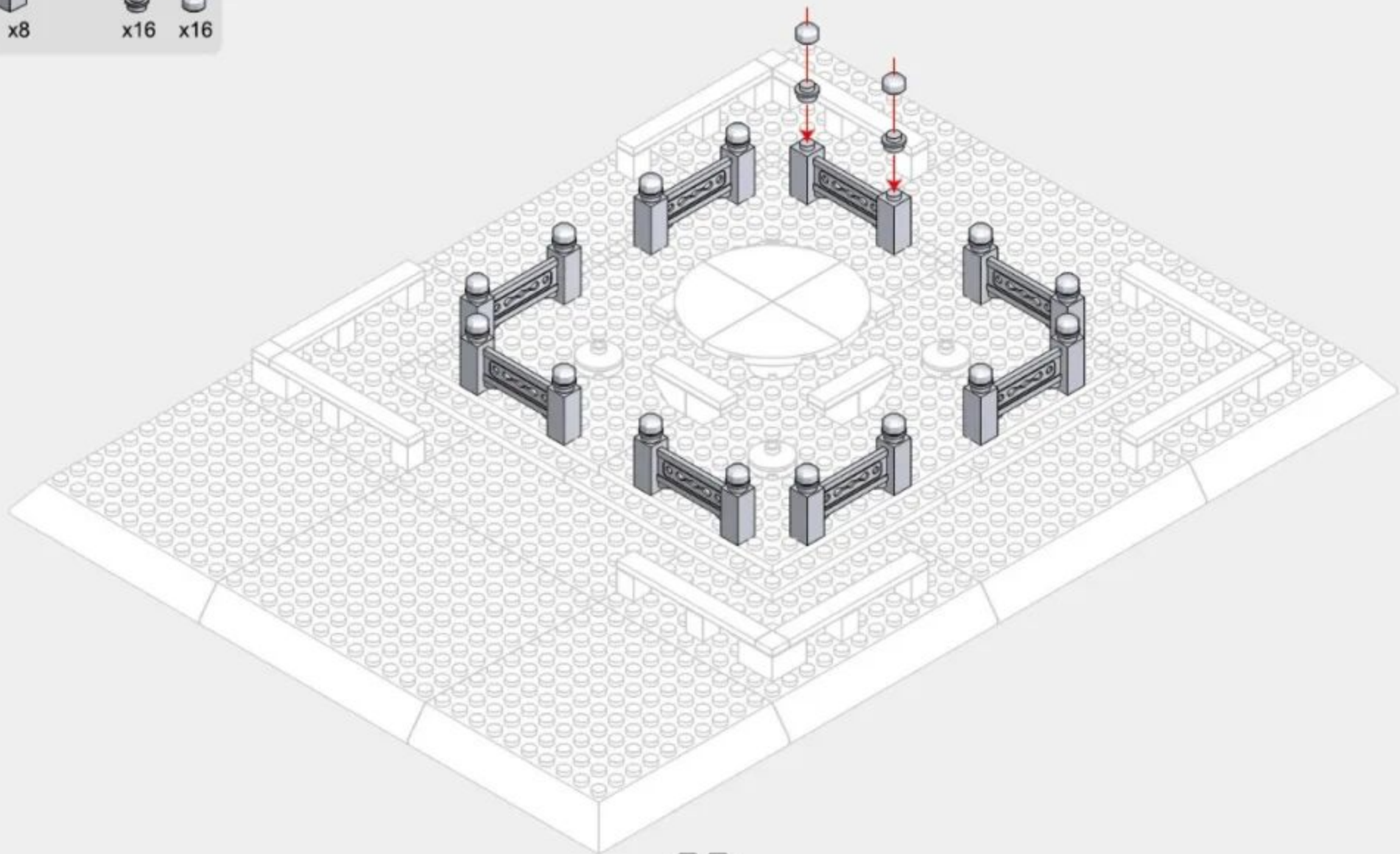
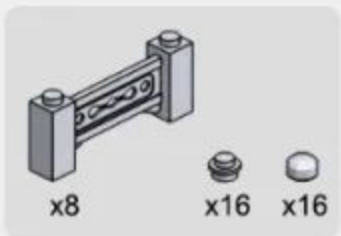

1-11

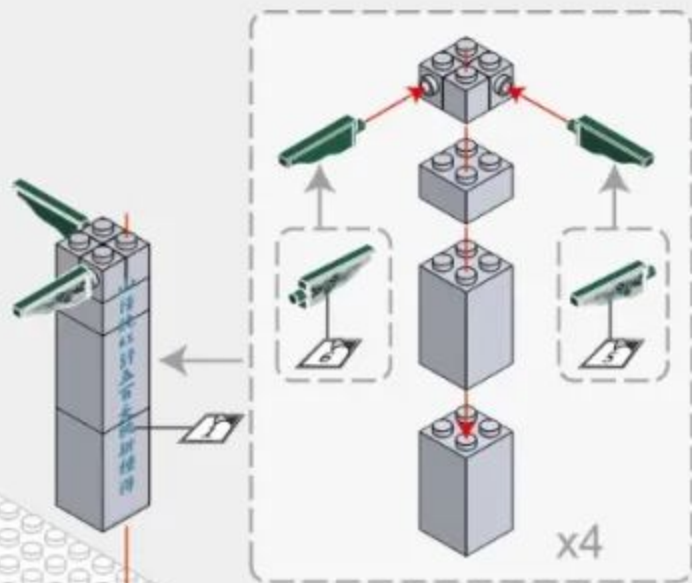
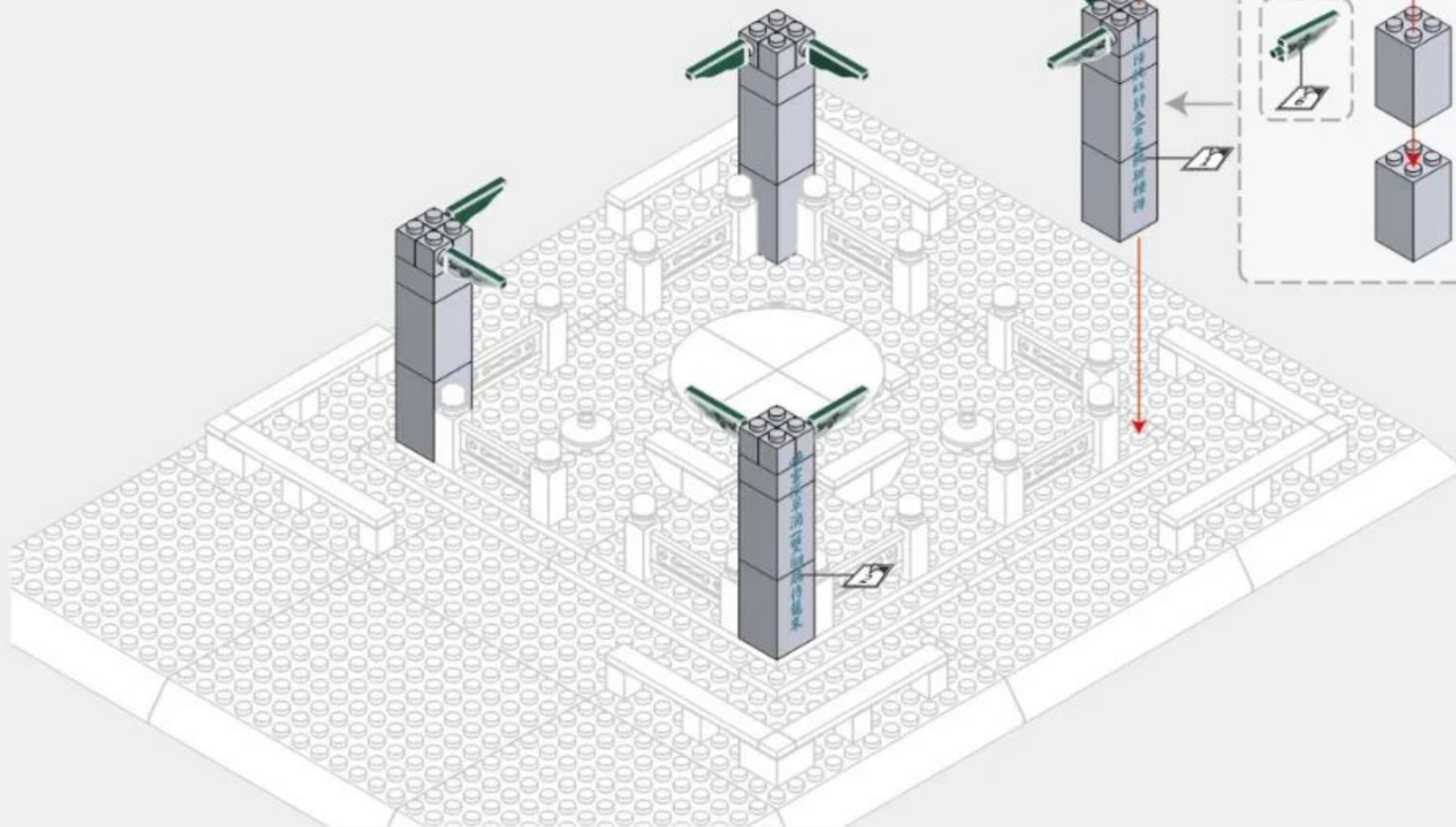
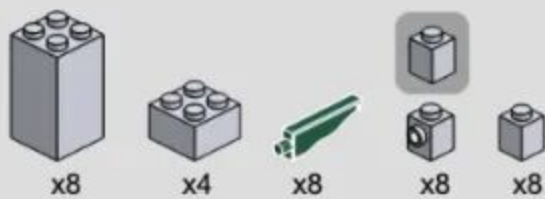

1-12

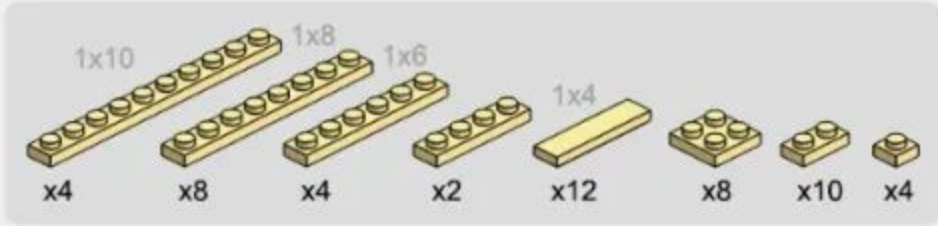

1

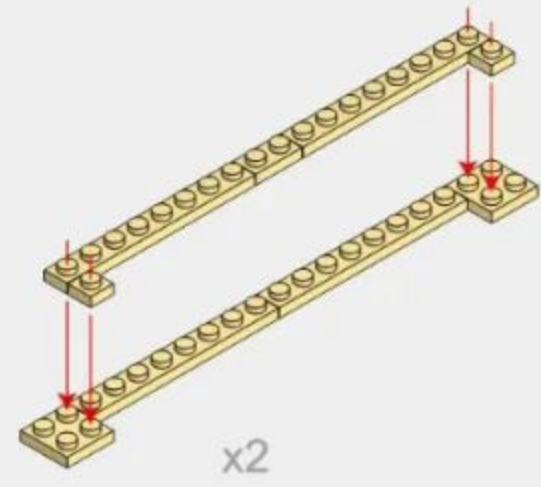

2

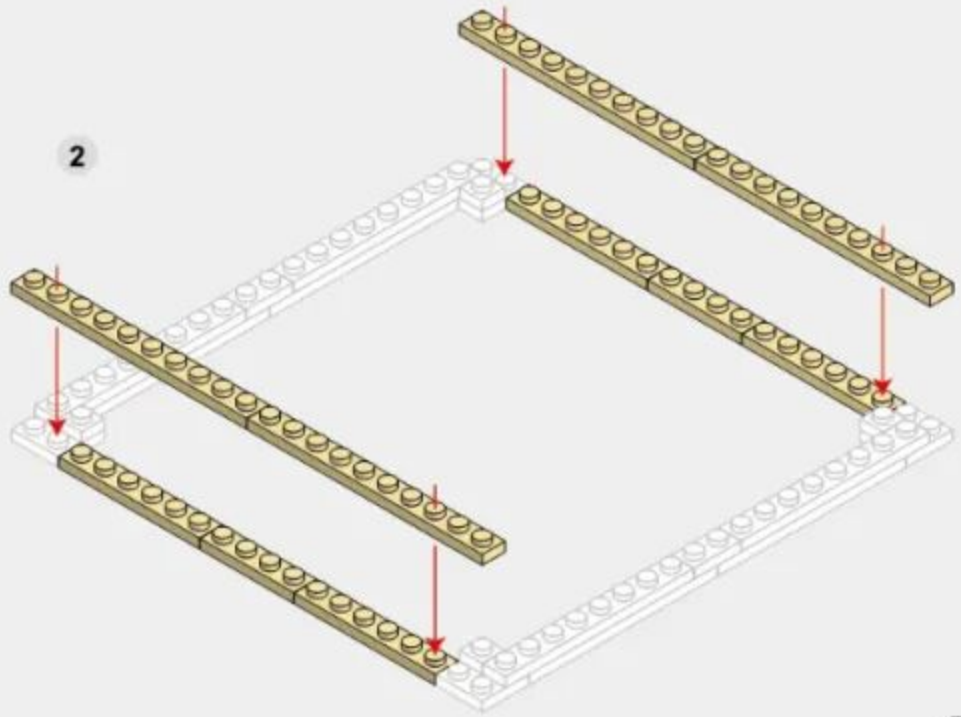

3

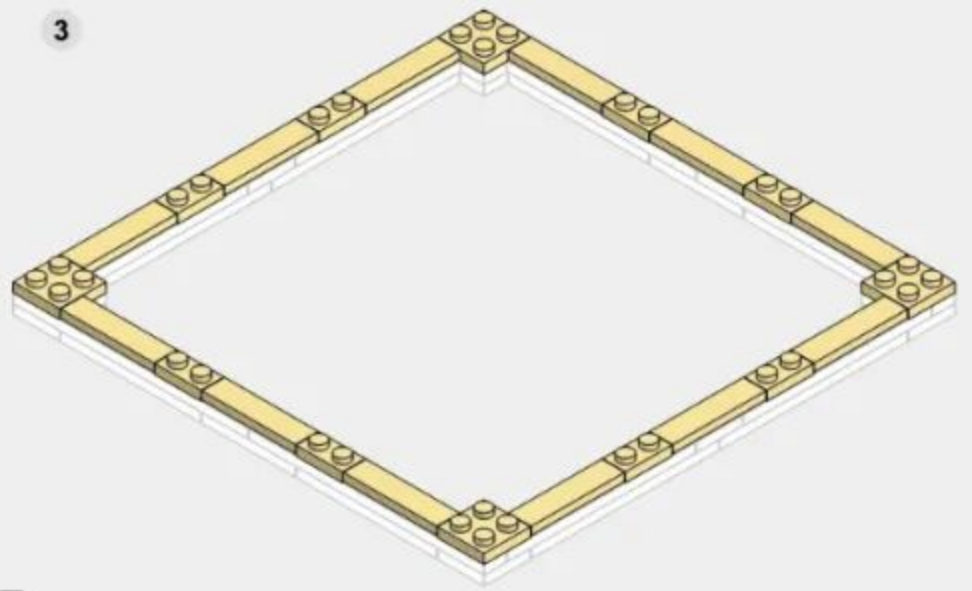

1-13

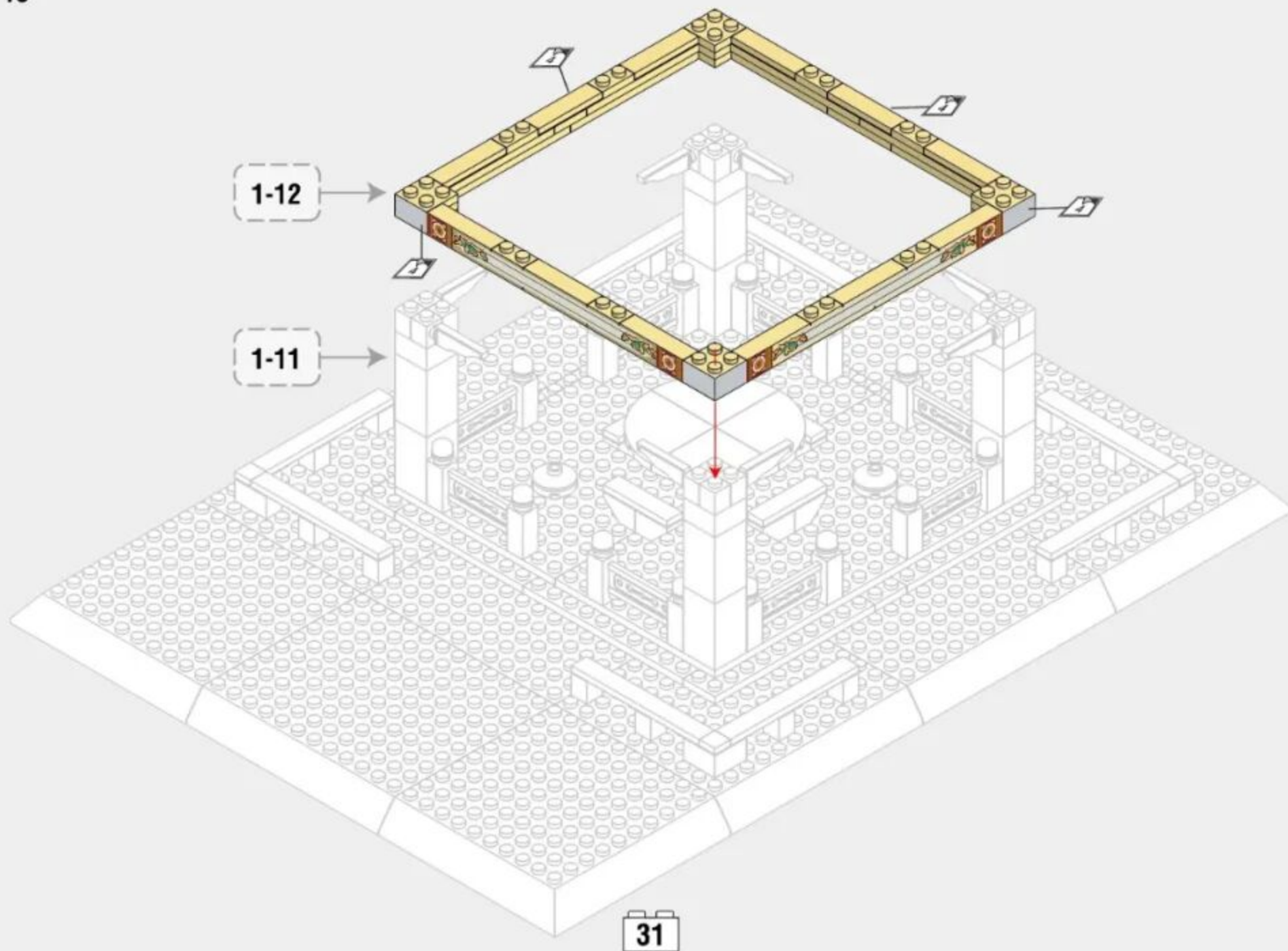



226PCS

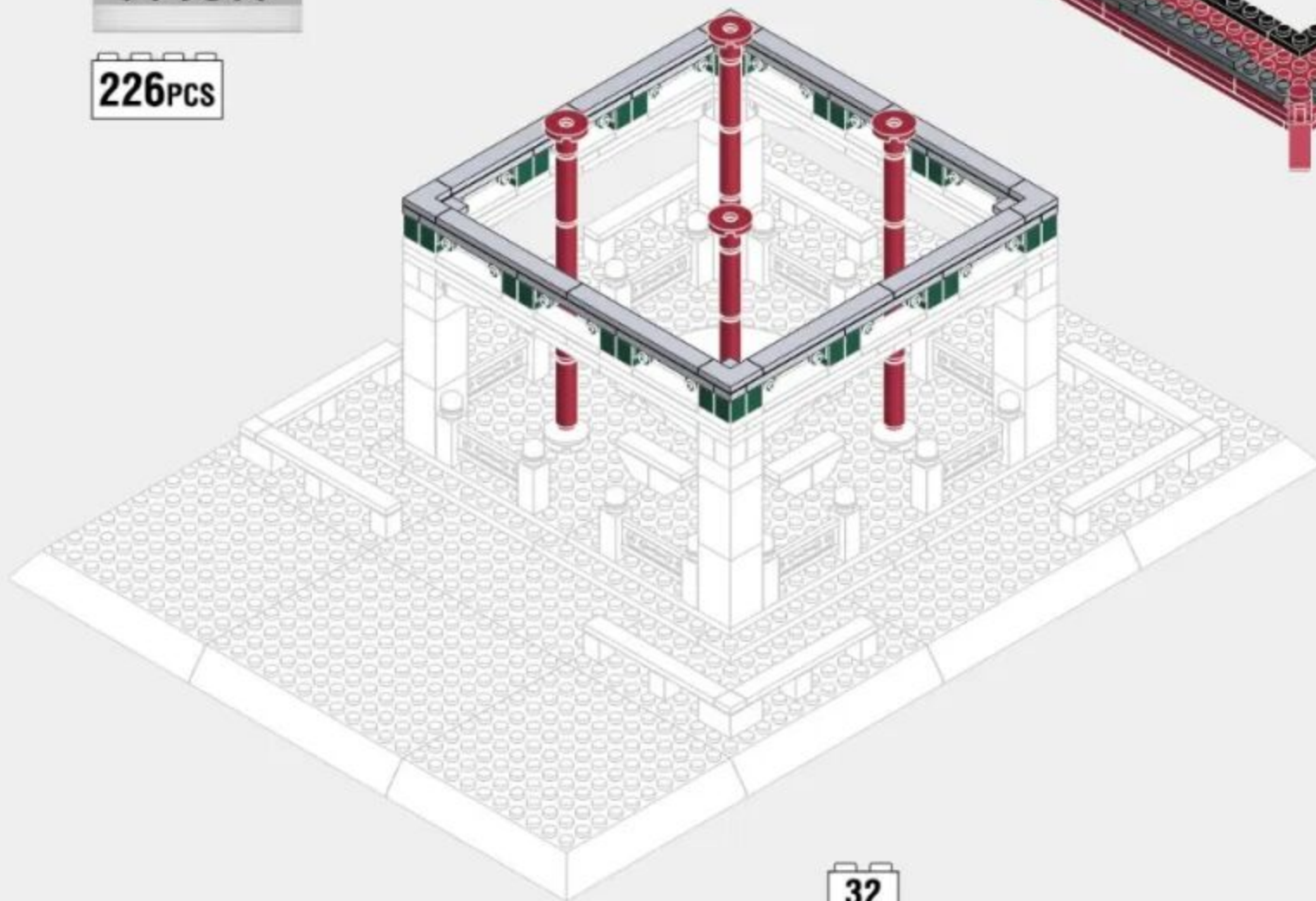

32

2-3

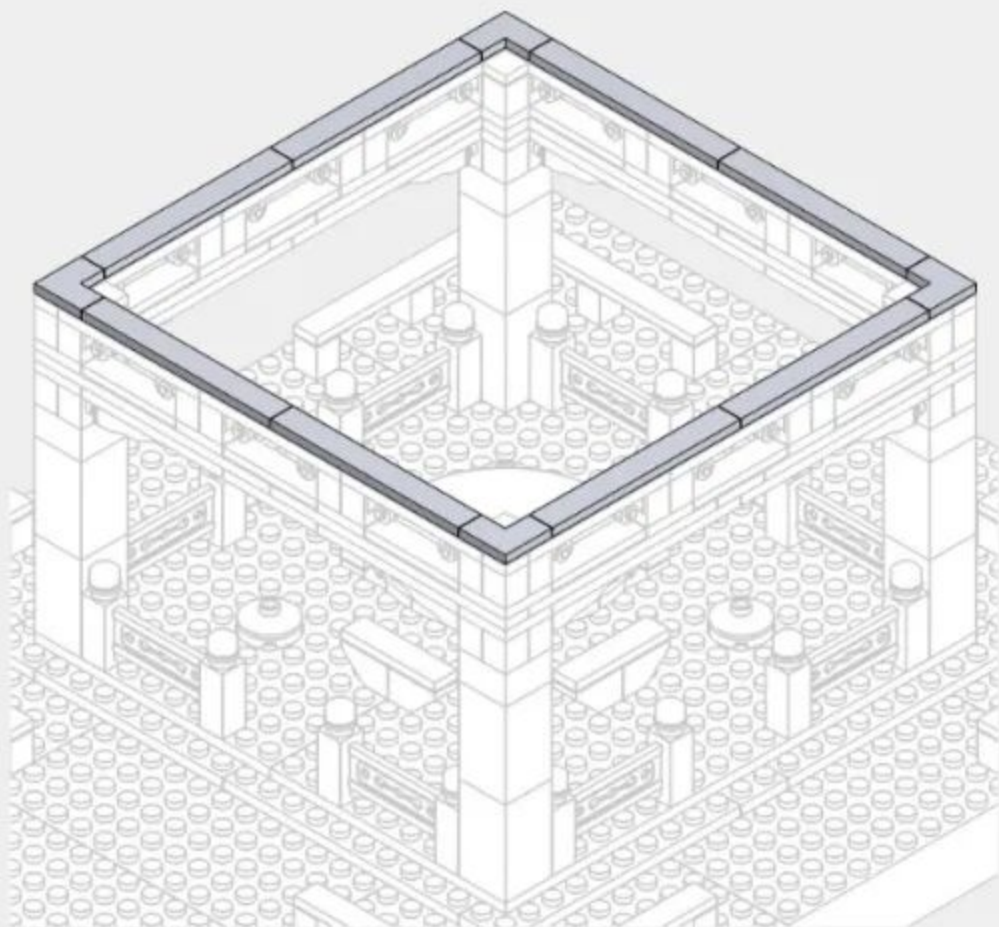
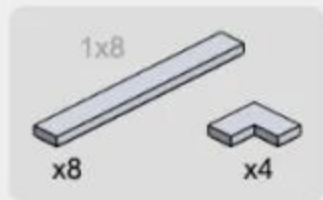

2-4

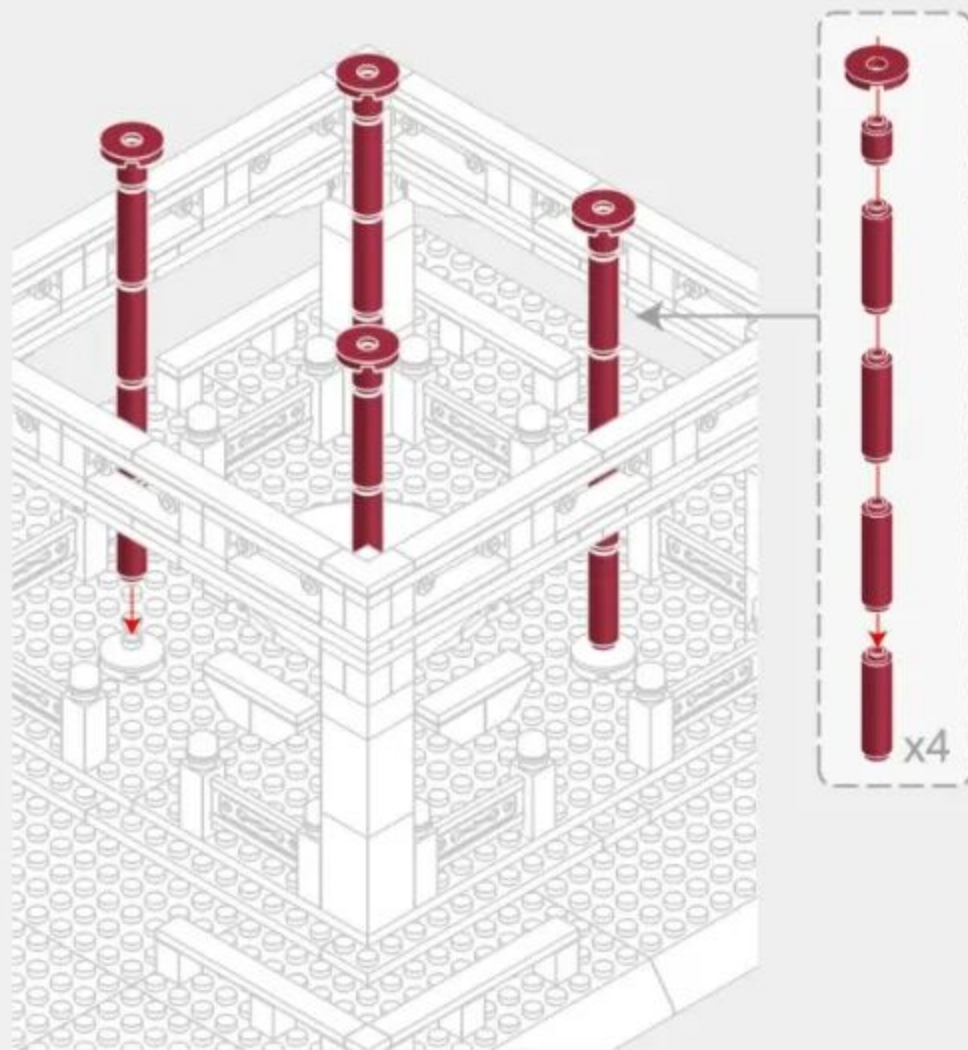

2-5

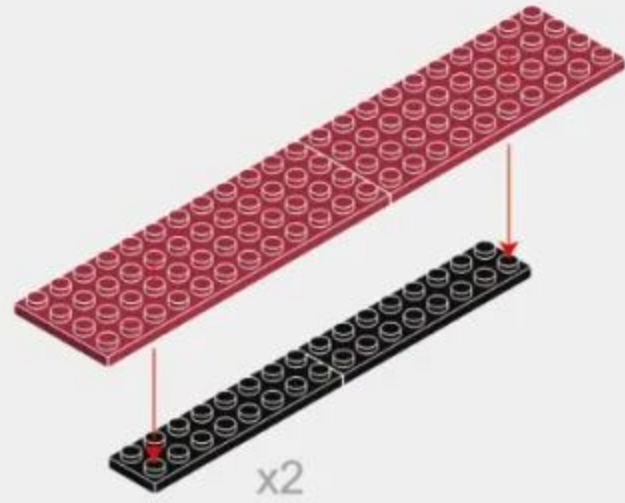
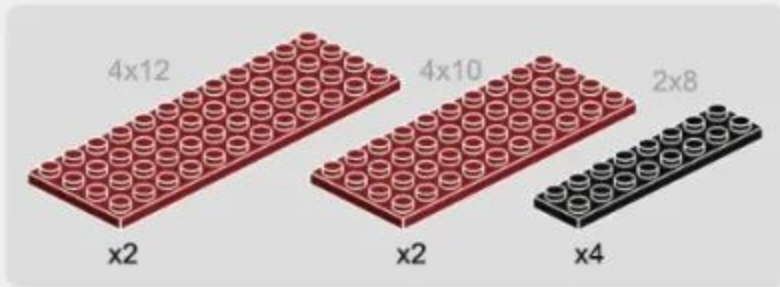

2-6

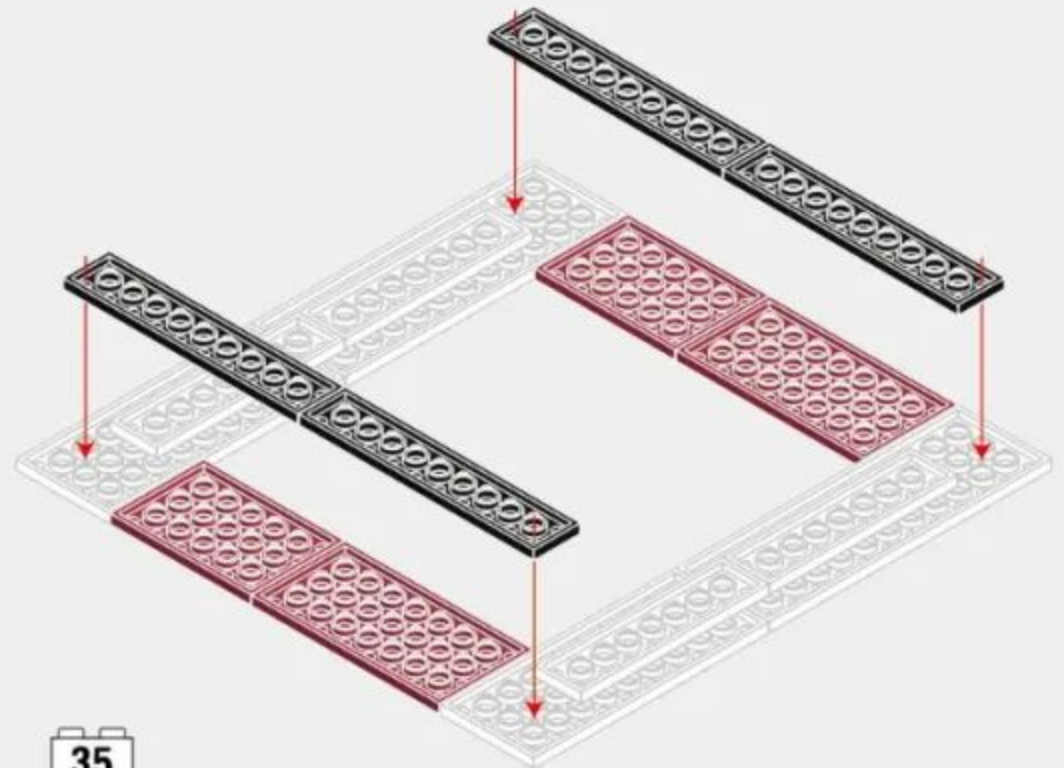
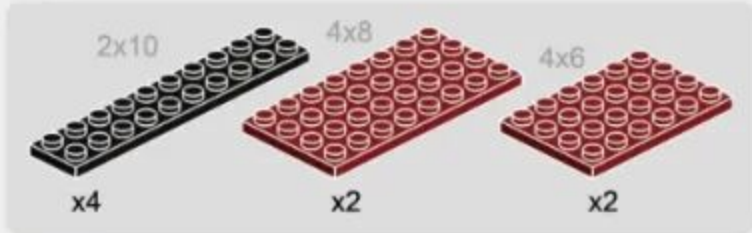

2-7

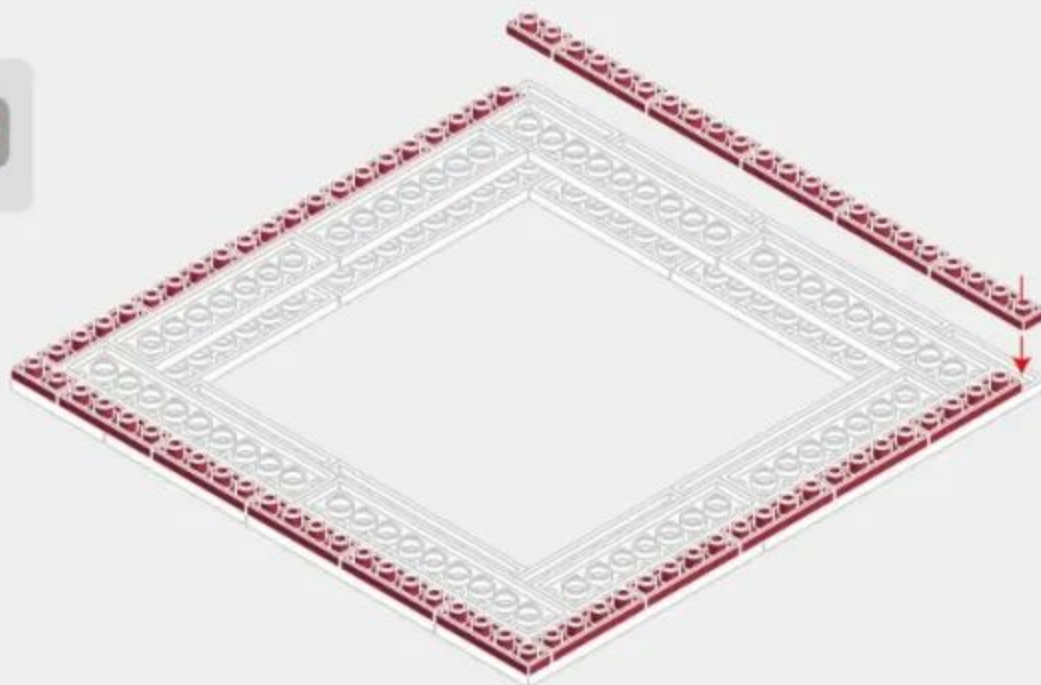

2-8

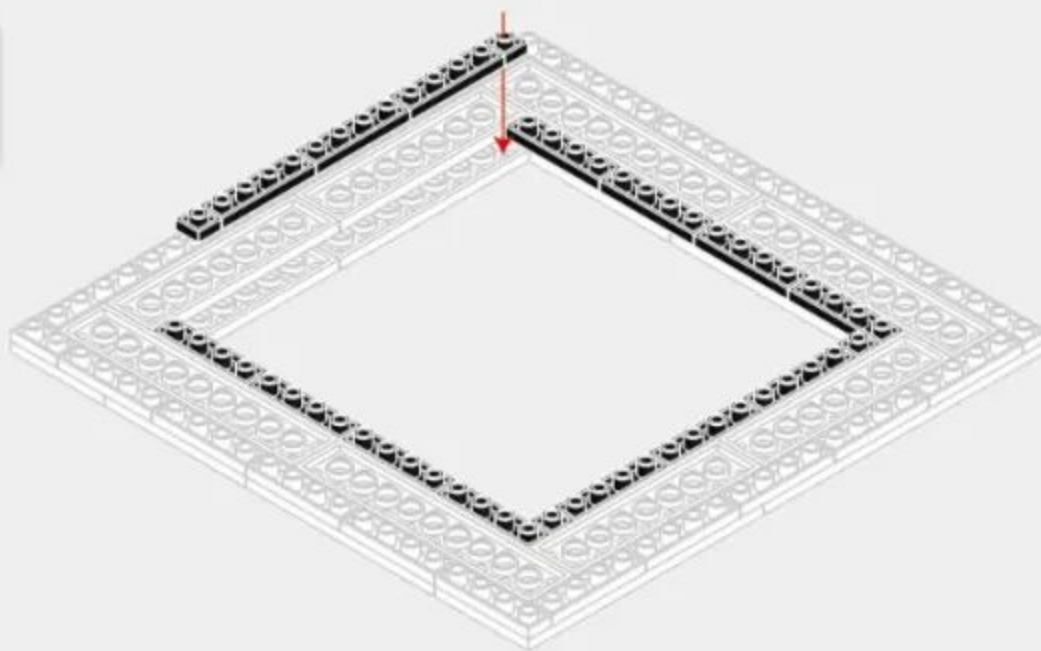

2-9

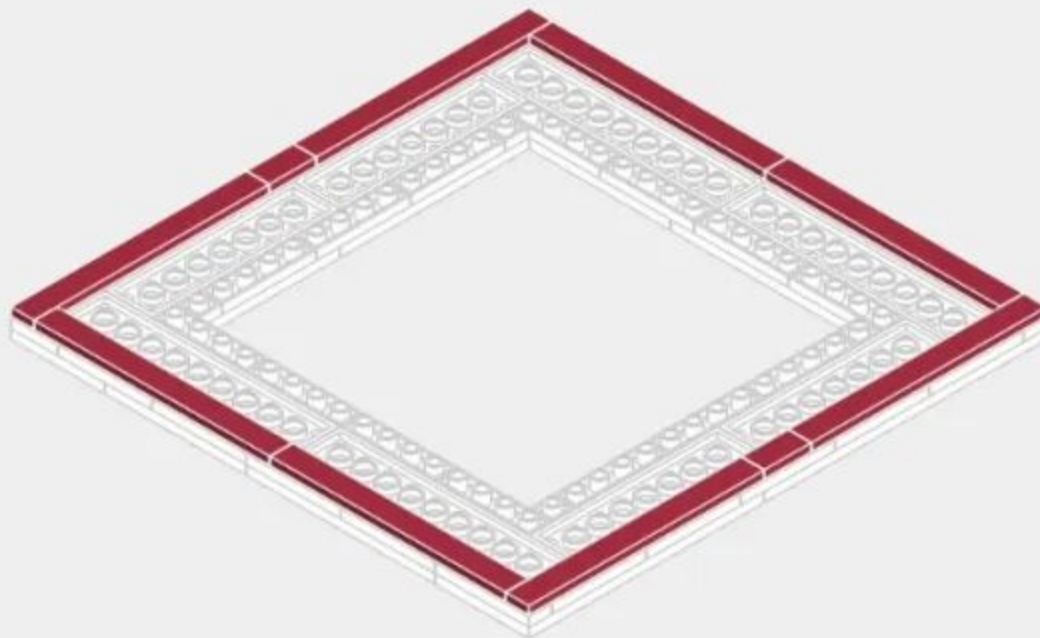
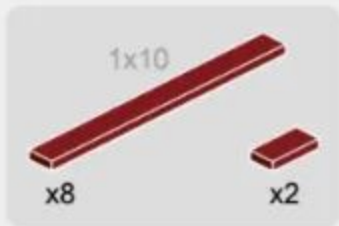

2-10

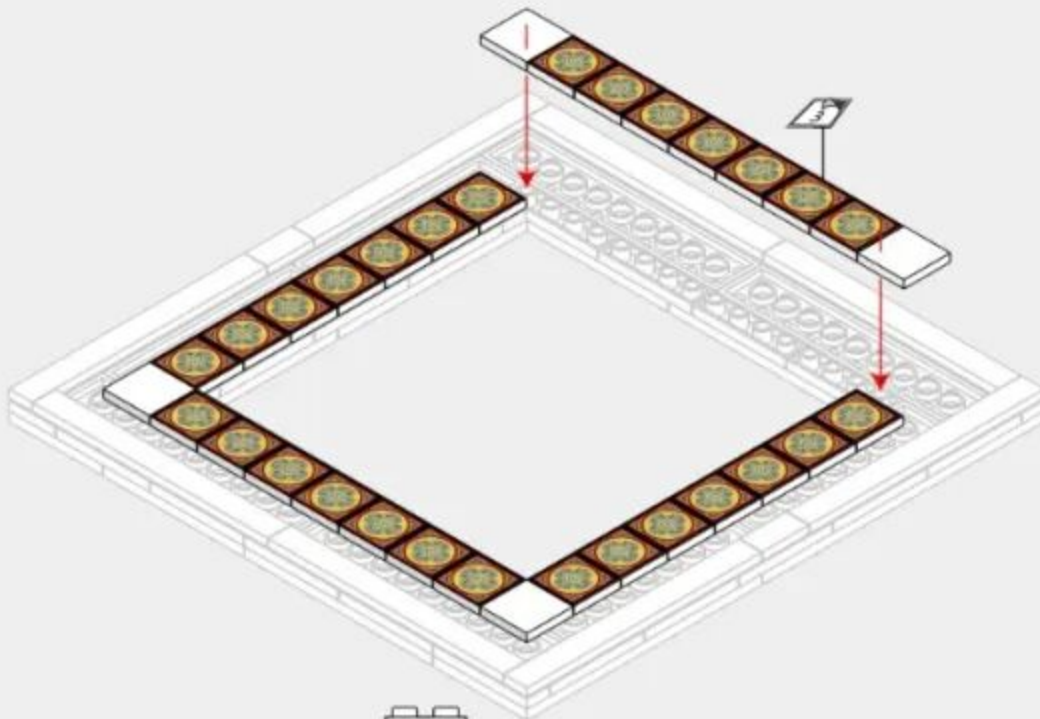

2-11

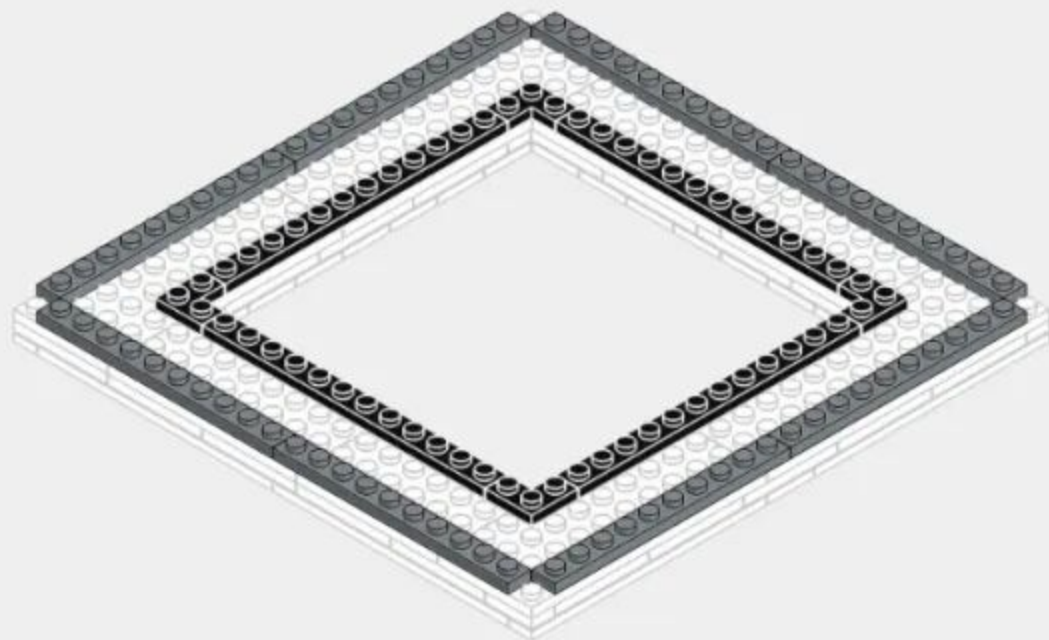
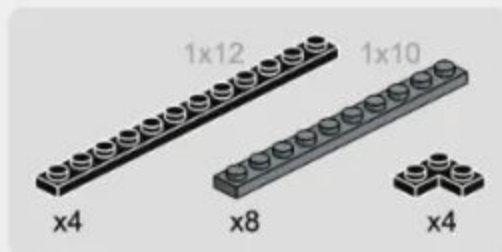

2-12

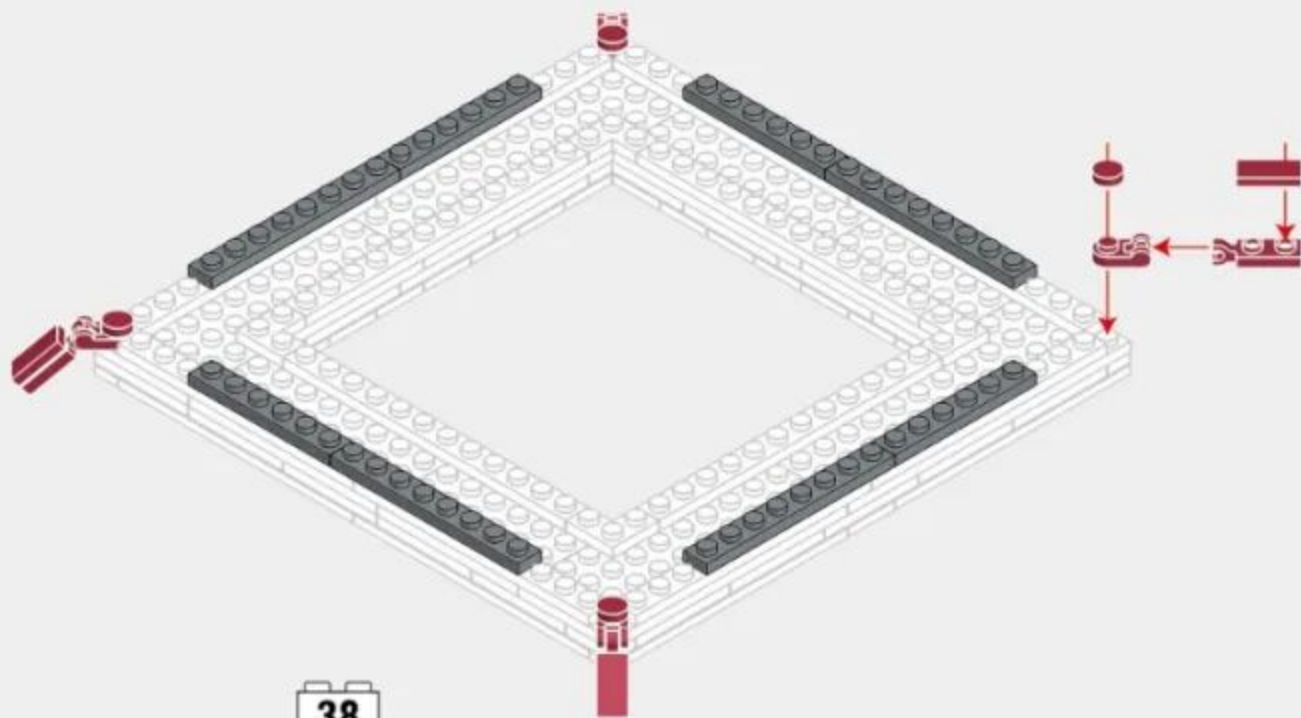



275PCS

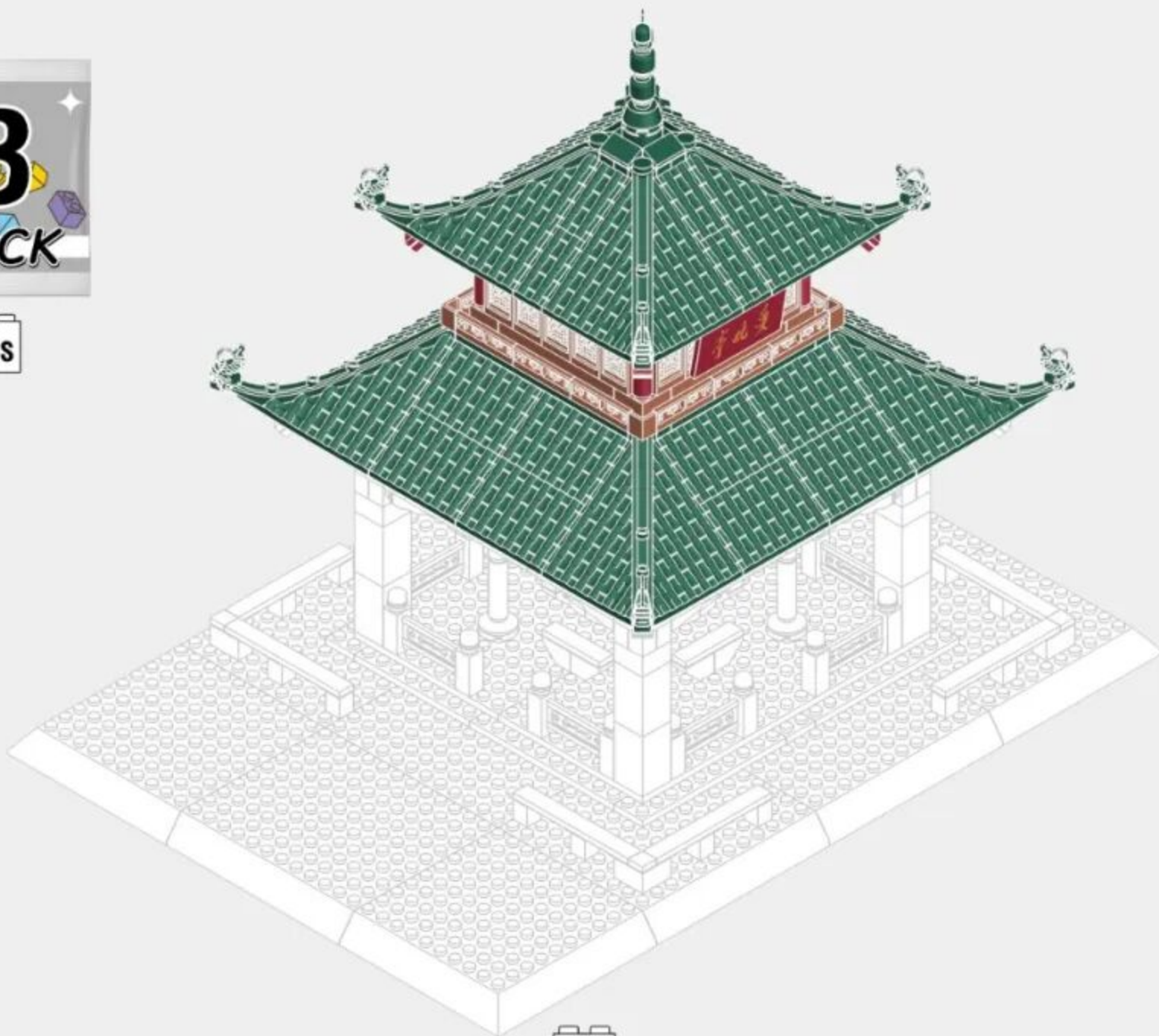

39

3-1

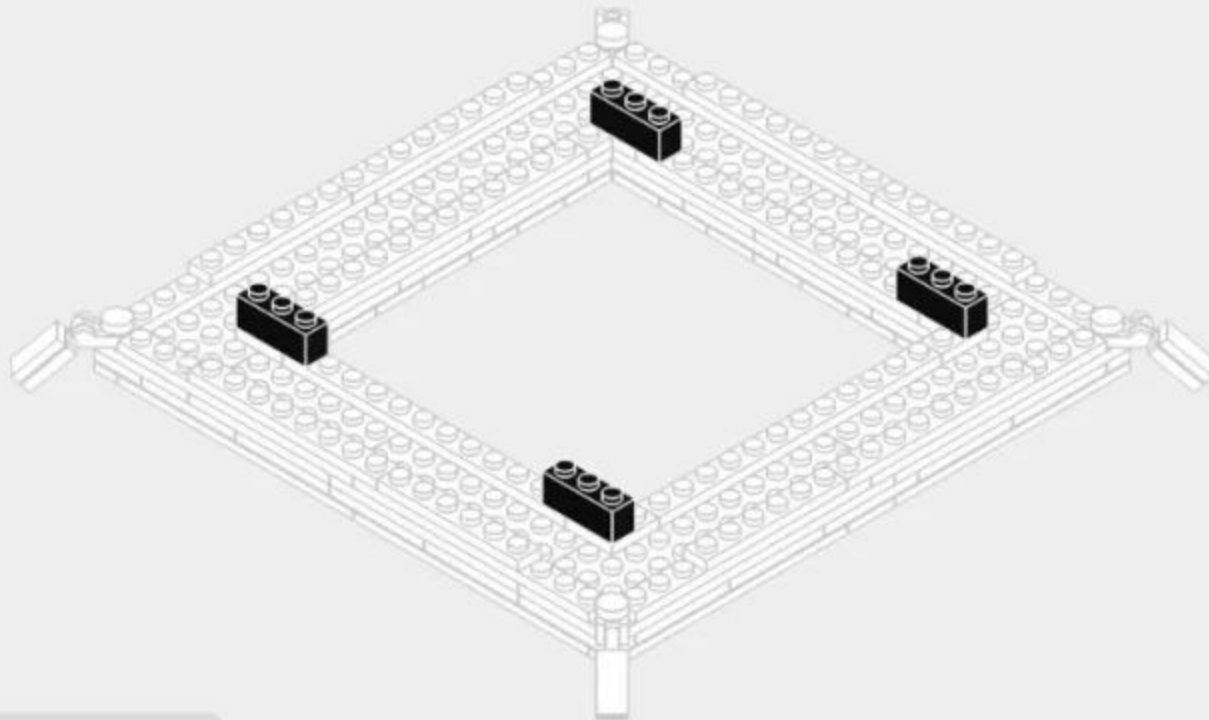

3-2

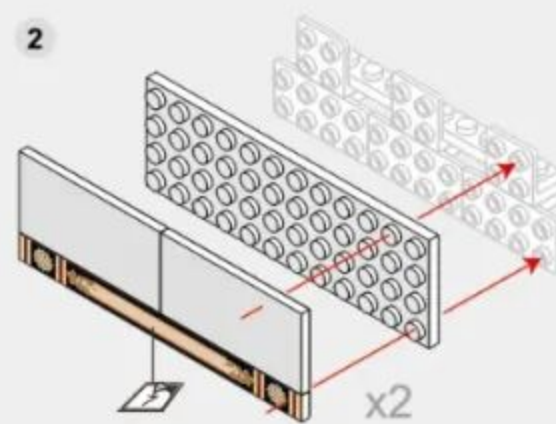
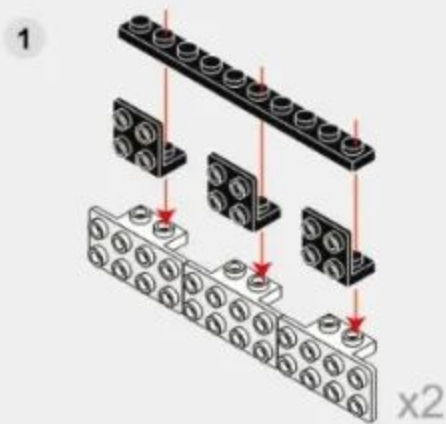
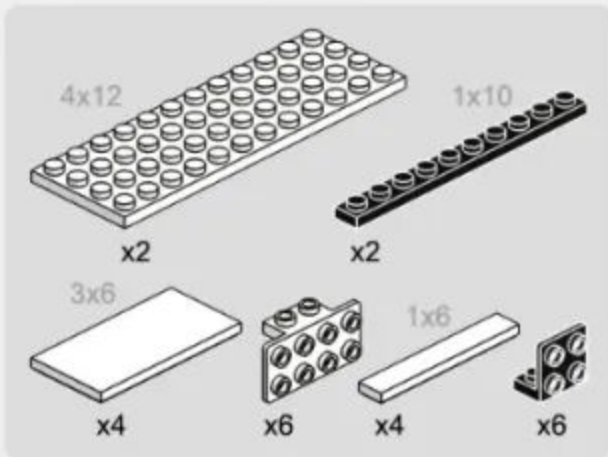

3-3

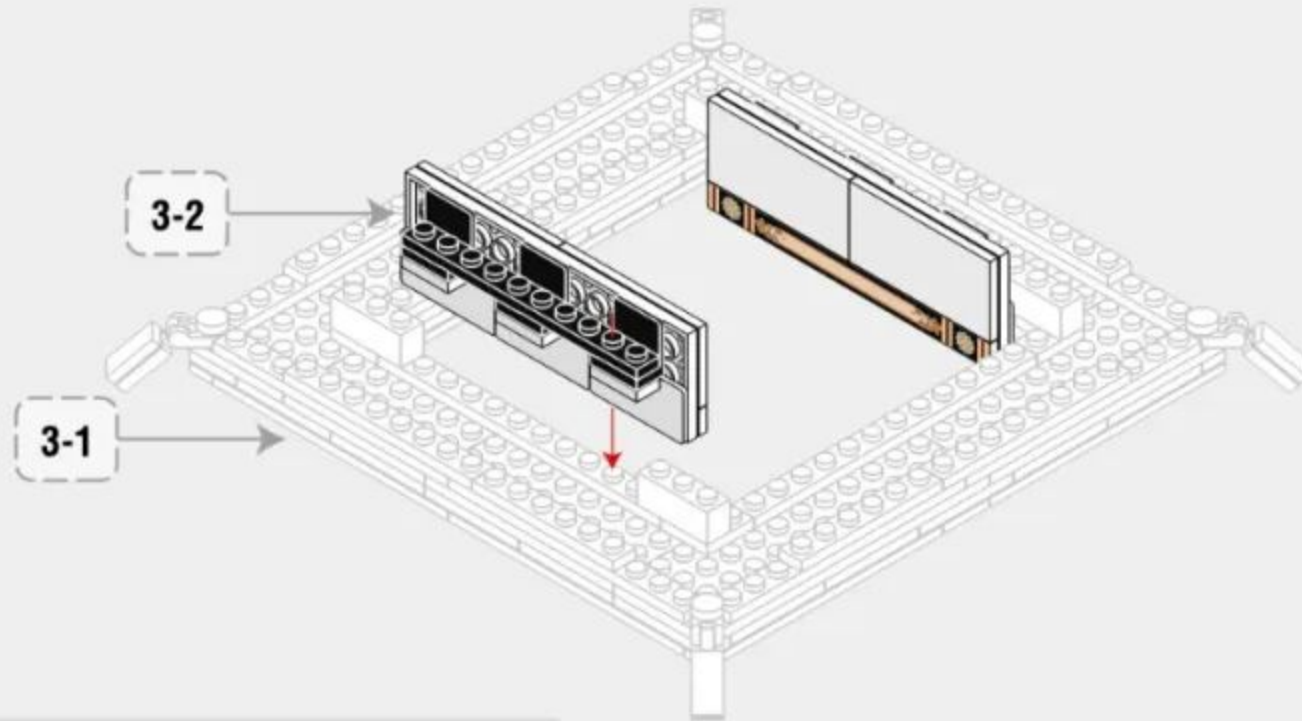

3-4

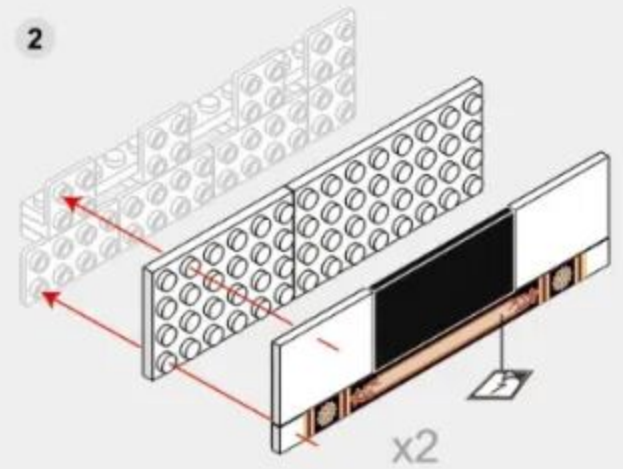
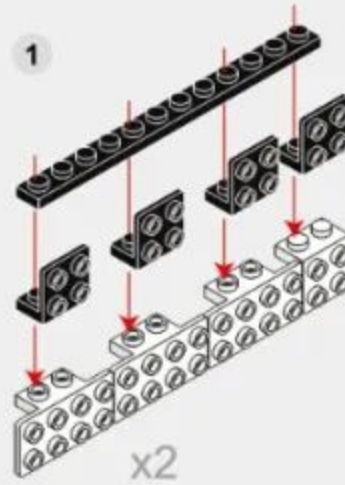
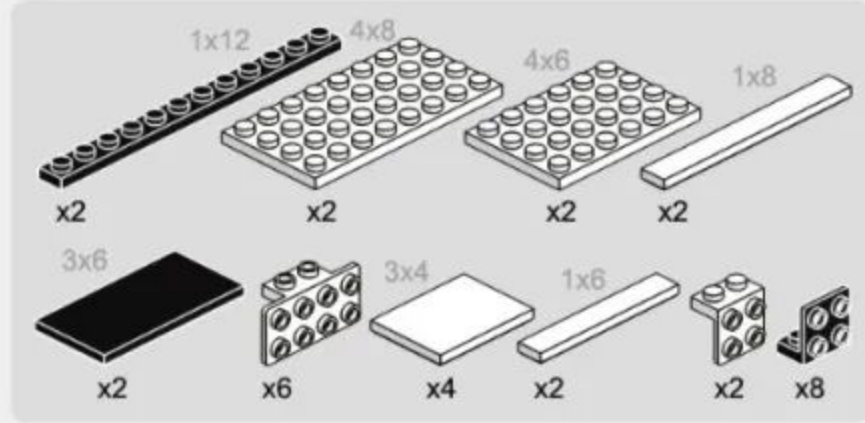

3-5

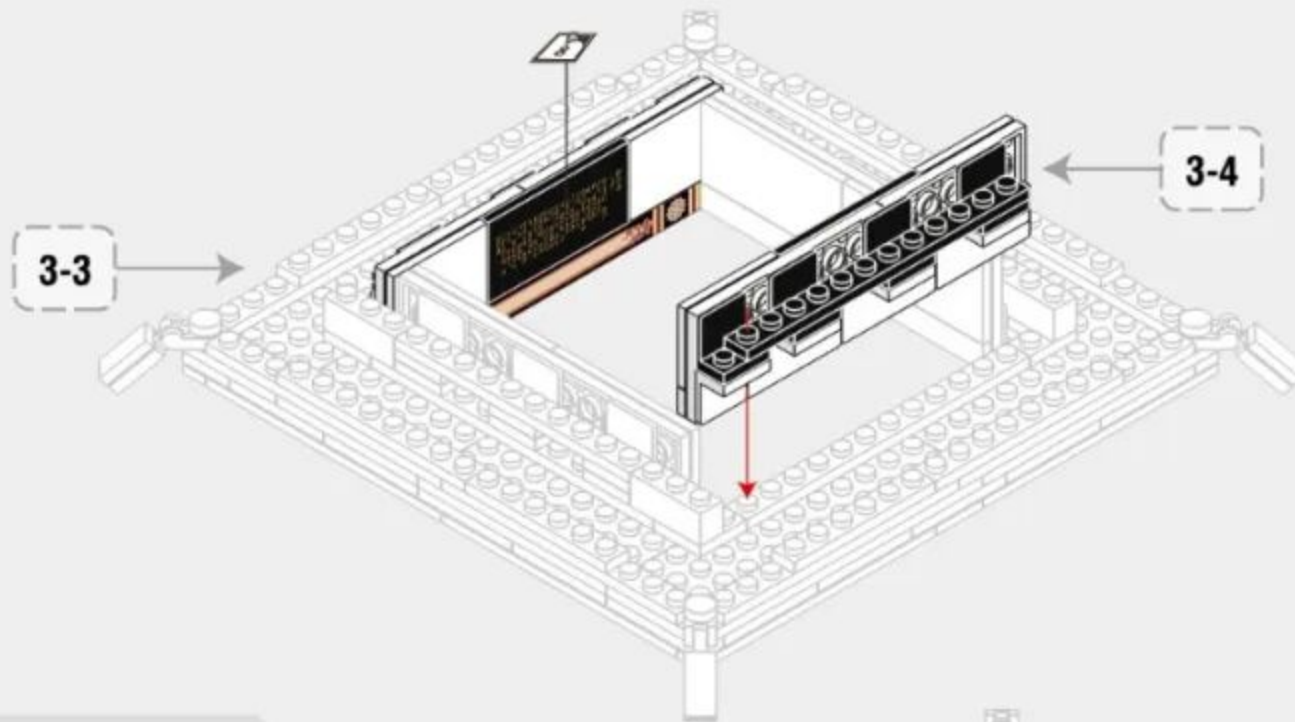

3-6

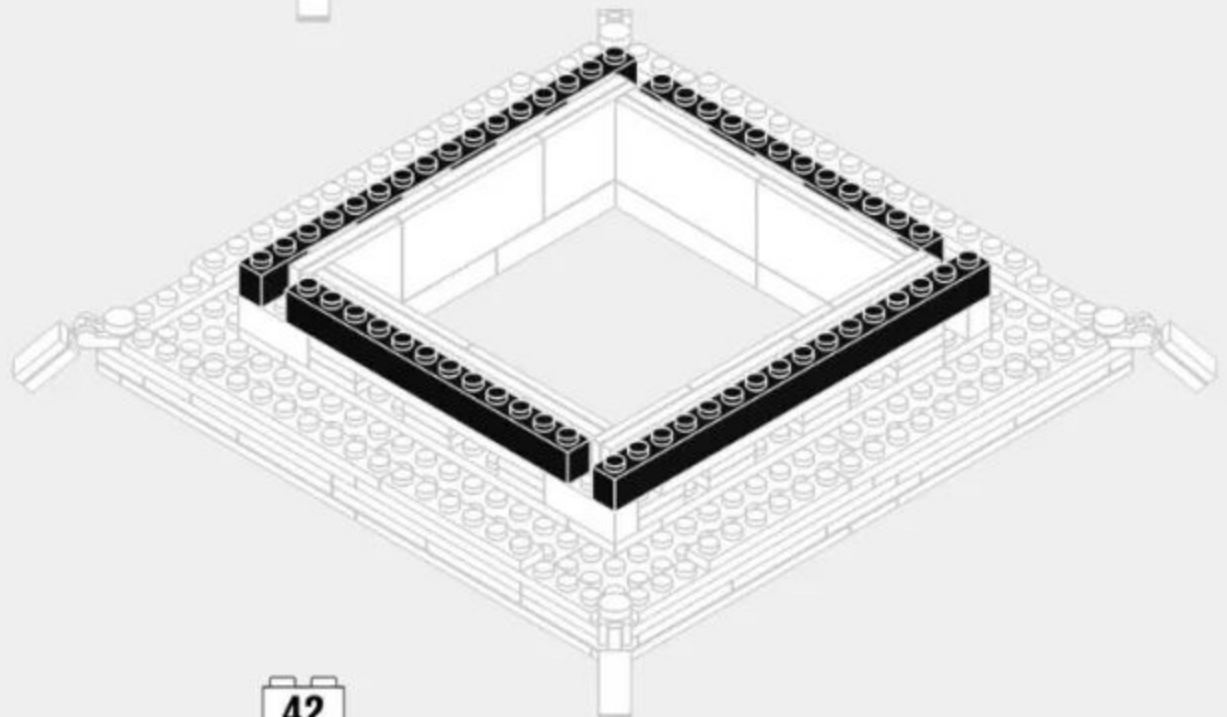
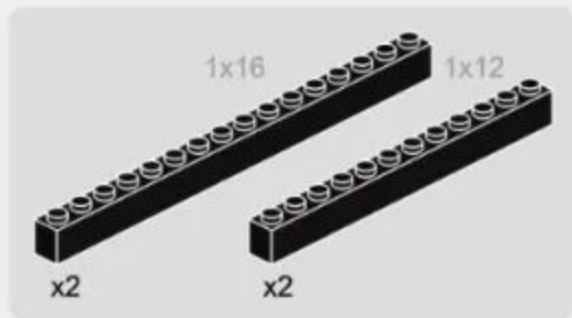

3-7

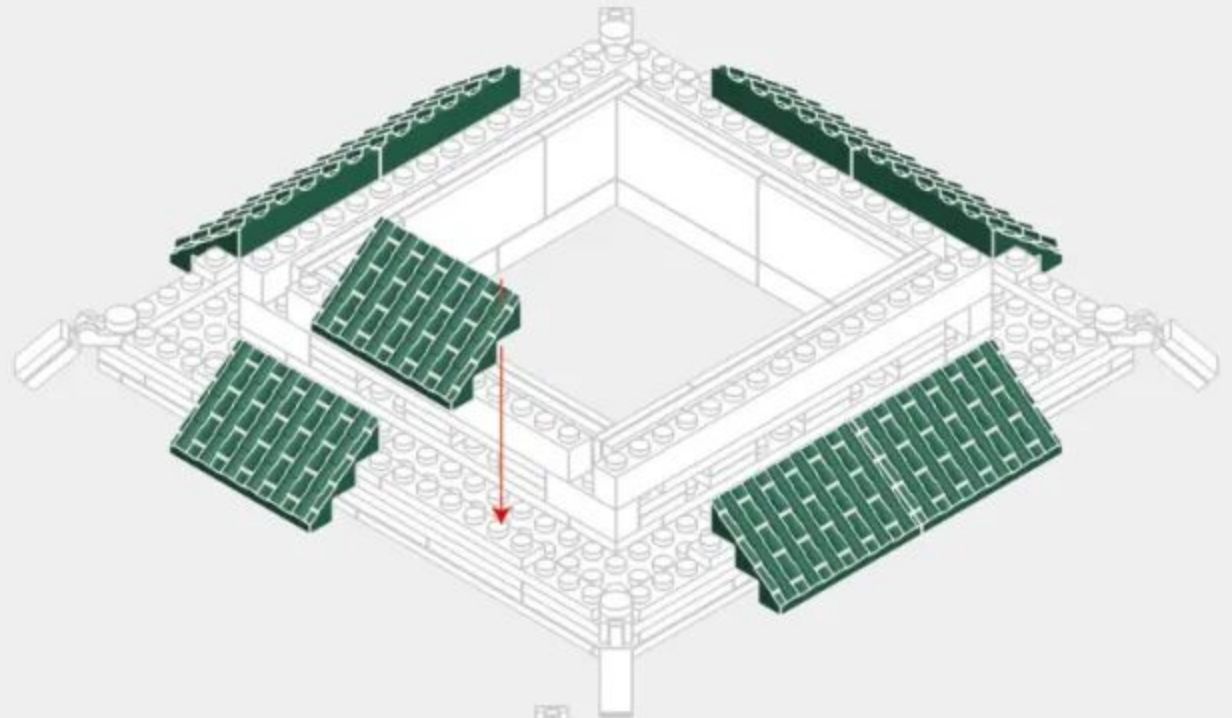
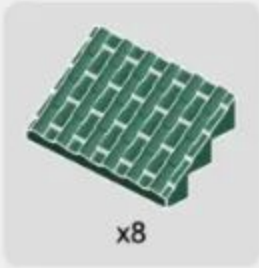

3-8

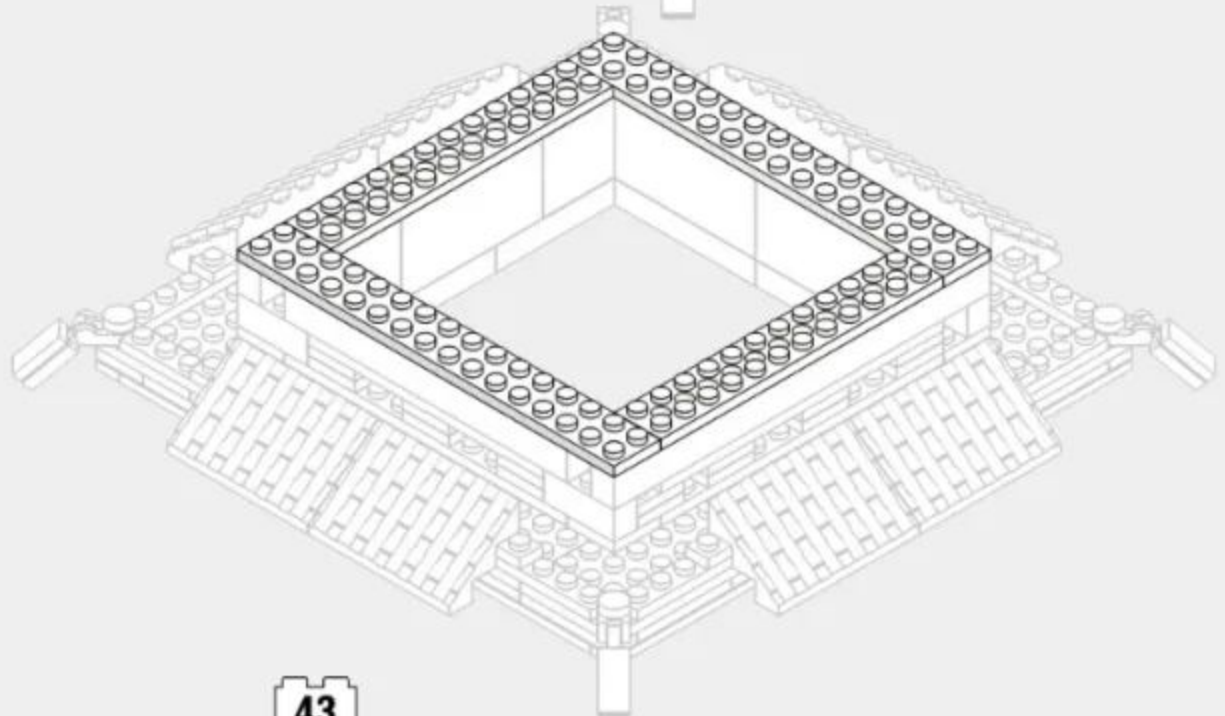
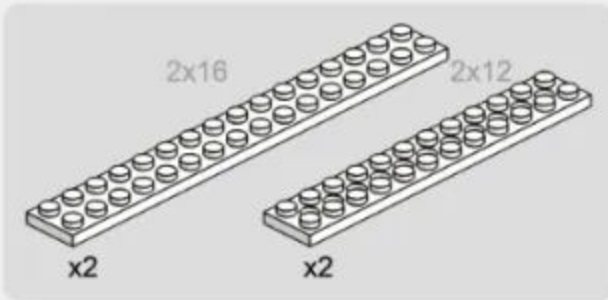

3-9

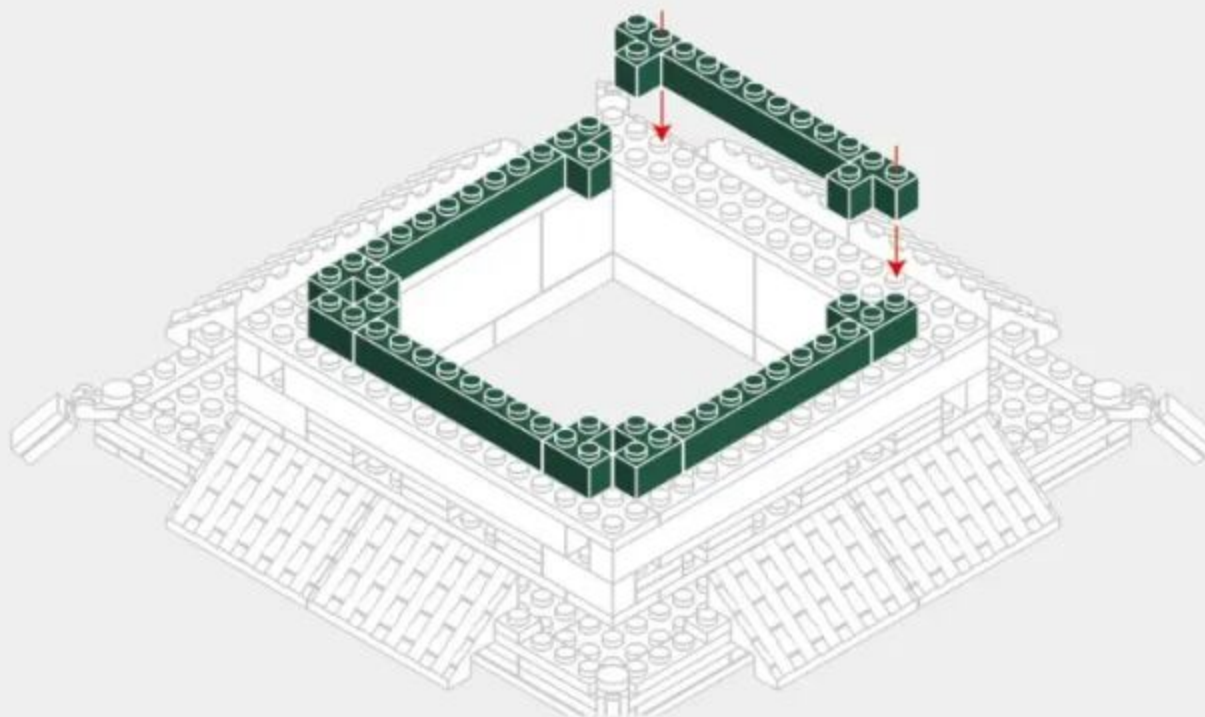
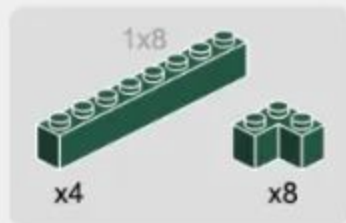

3-10

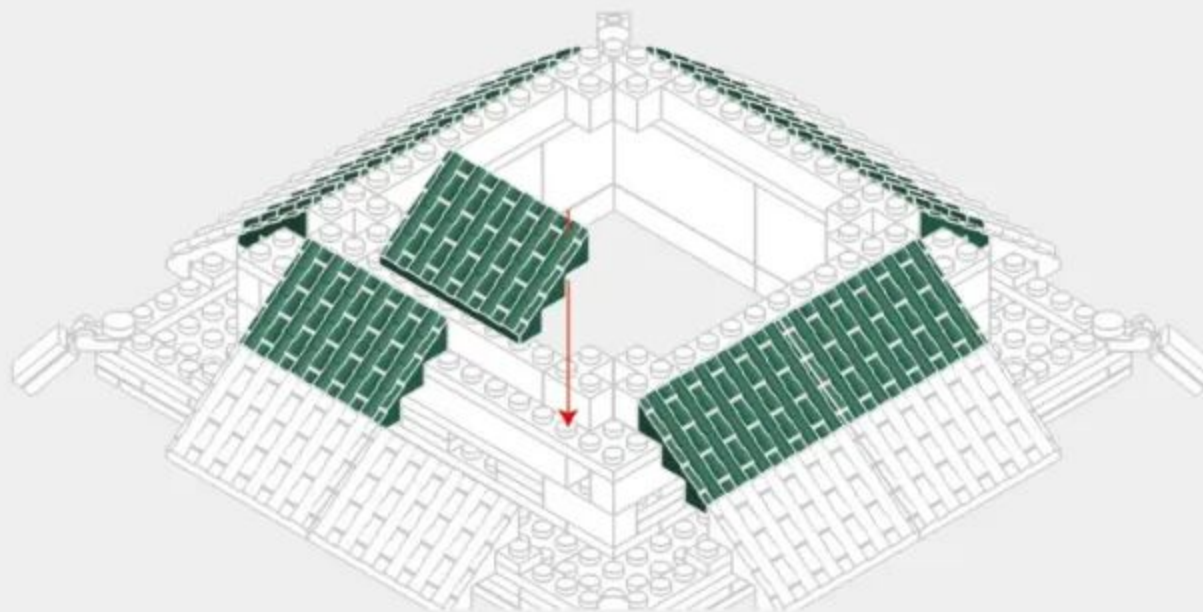
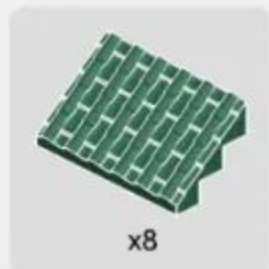

3-11

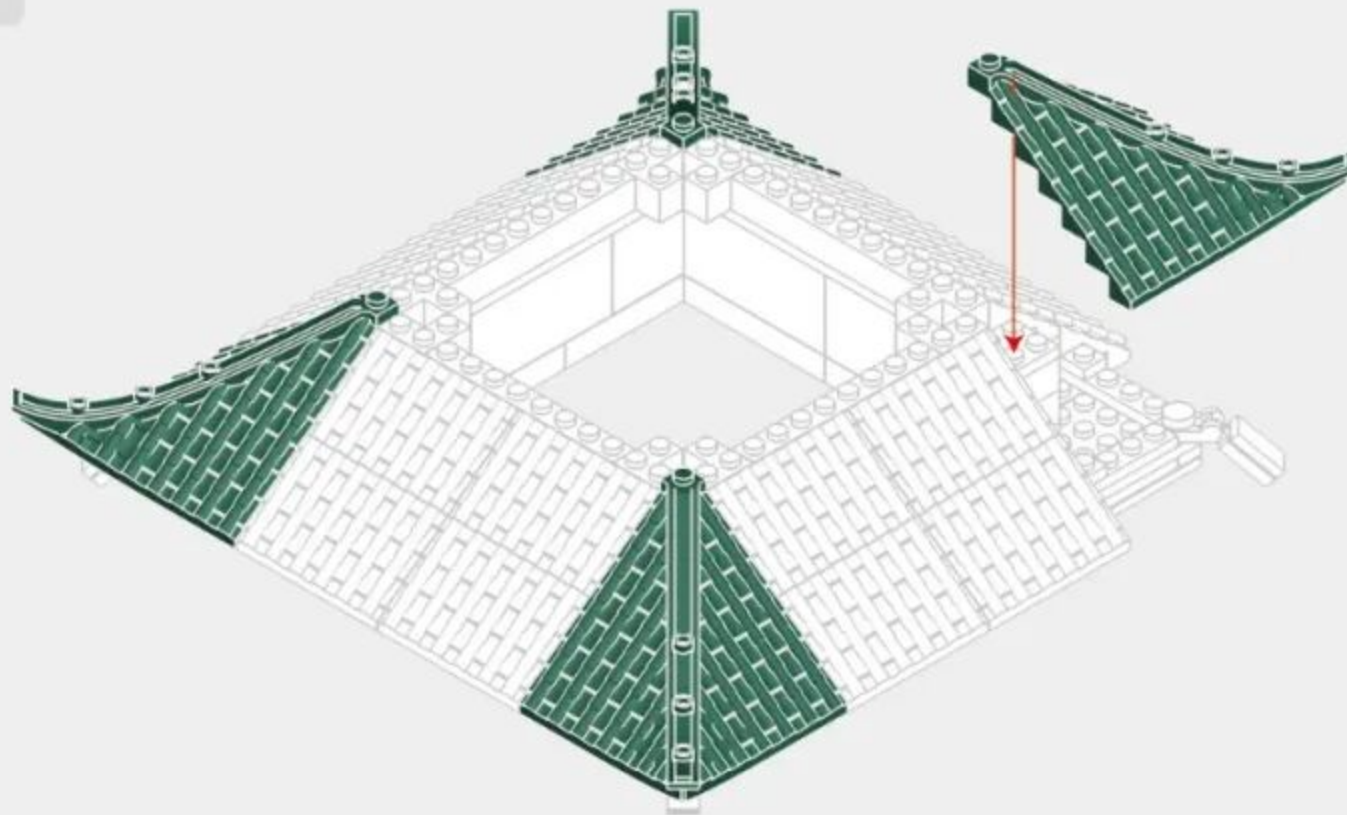

3-12

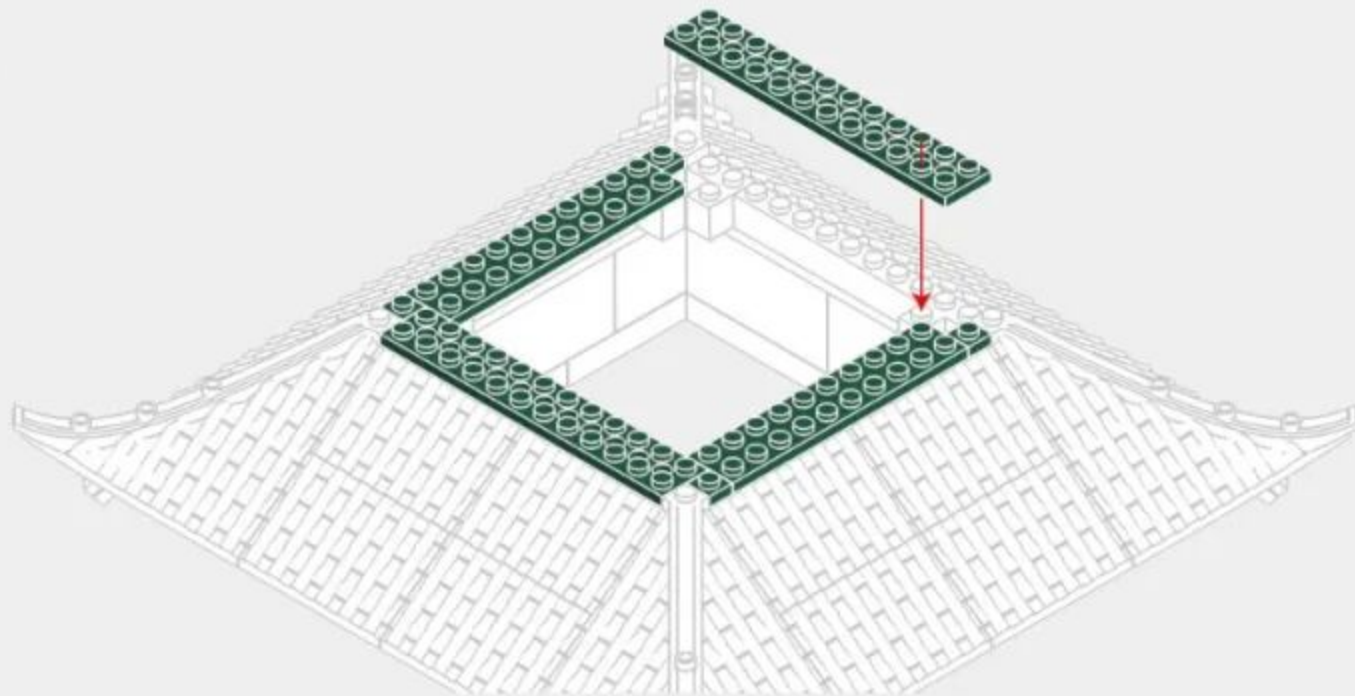
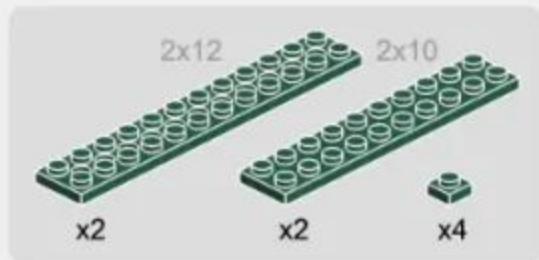

3-13

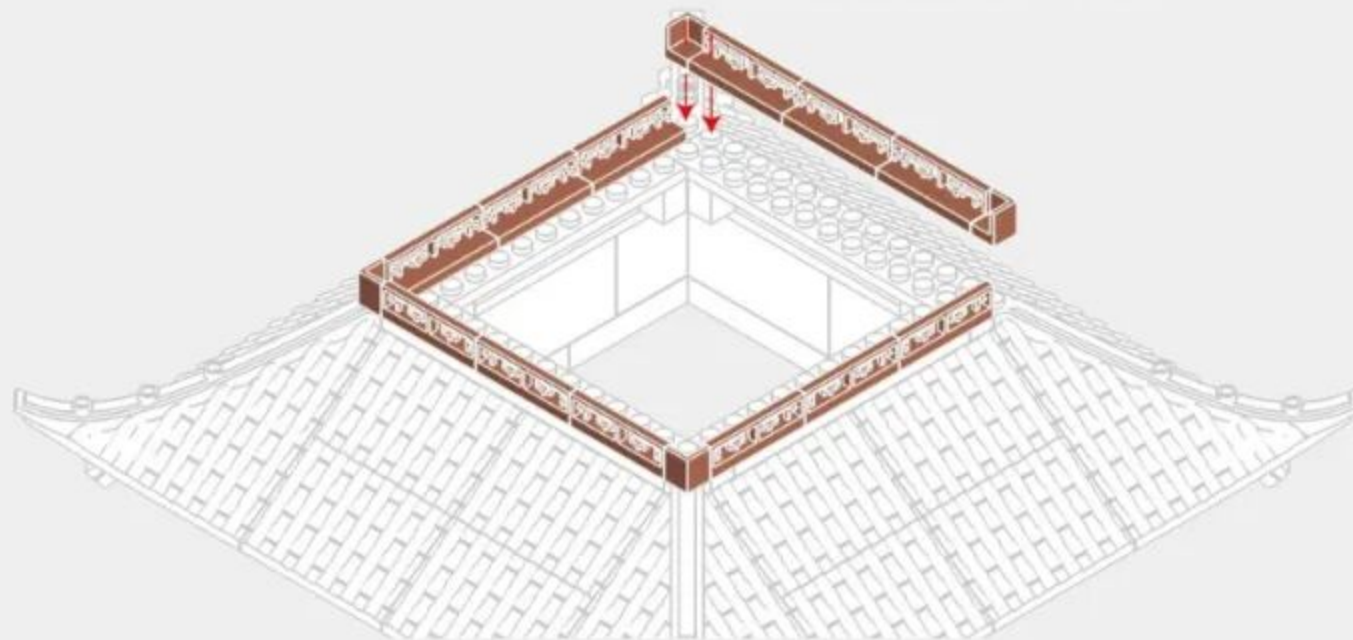

3-14

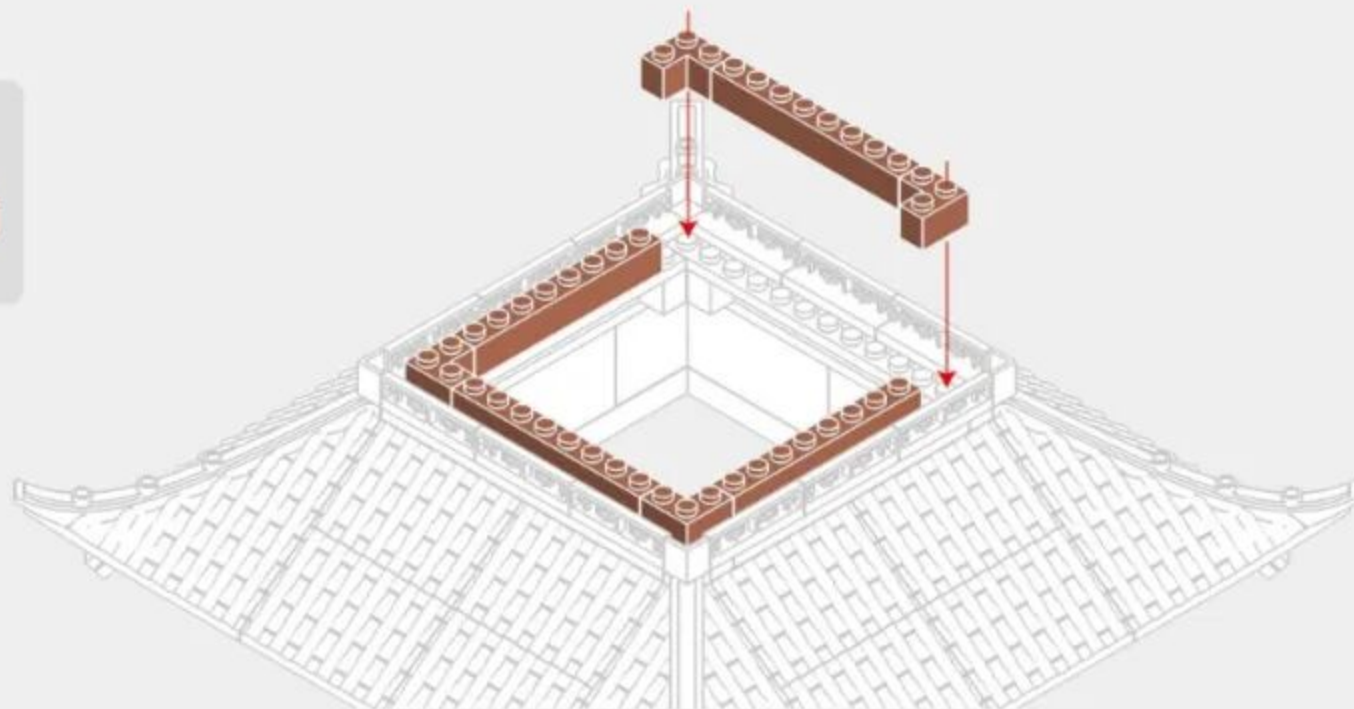
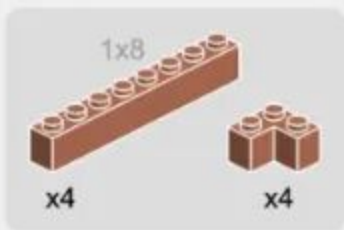

3-15

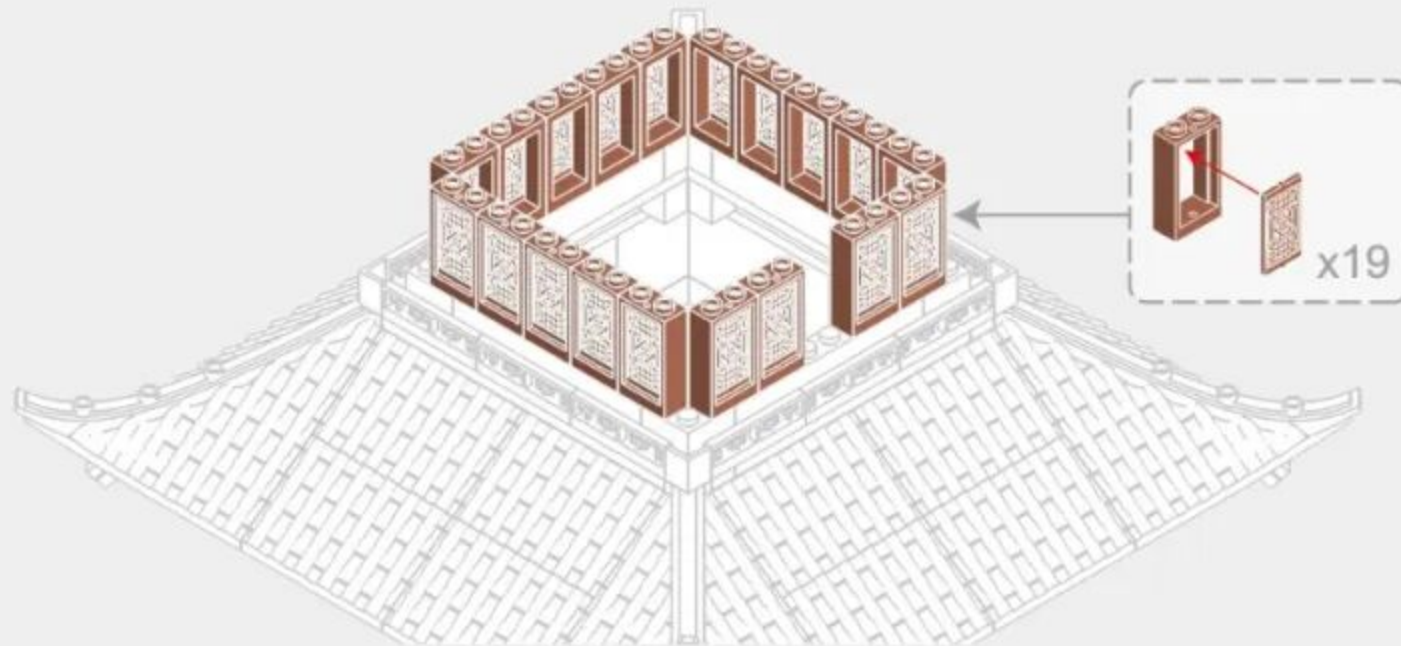

3-16

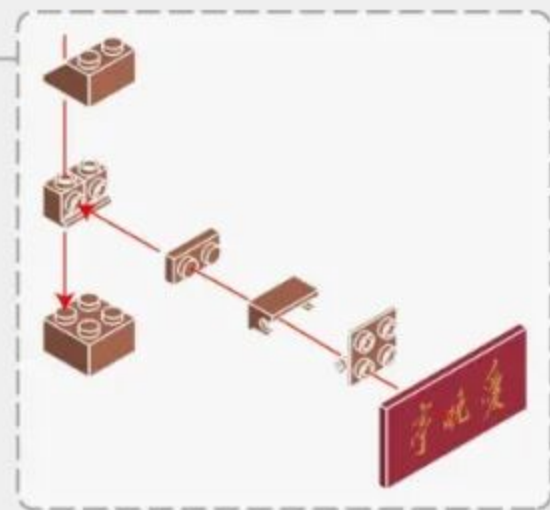
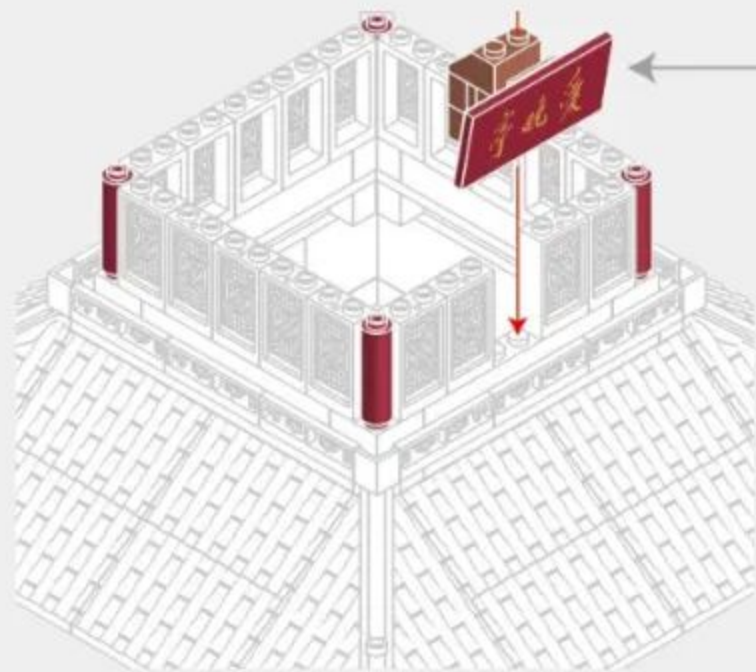
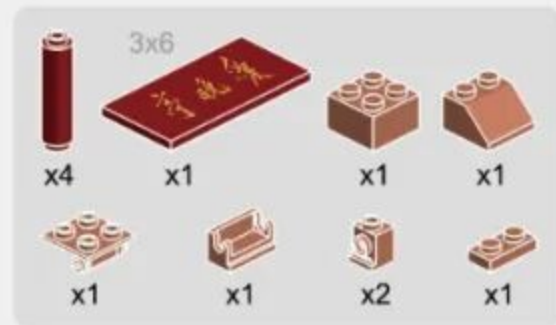

3-17

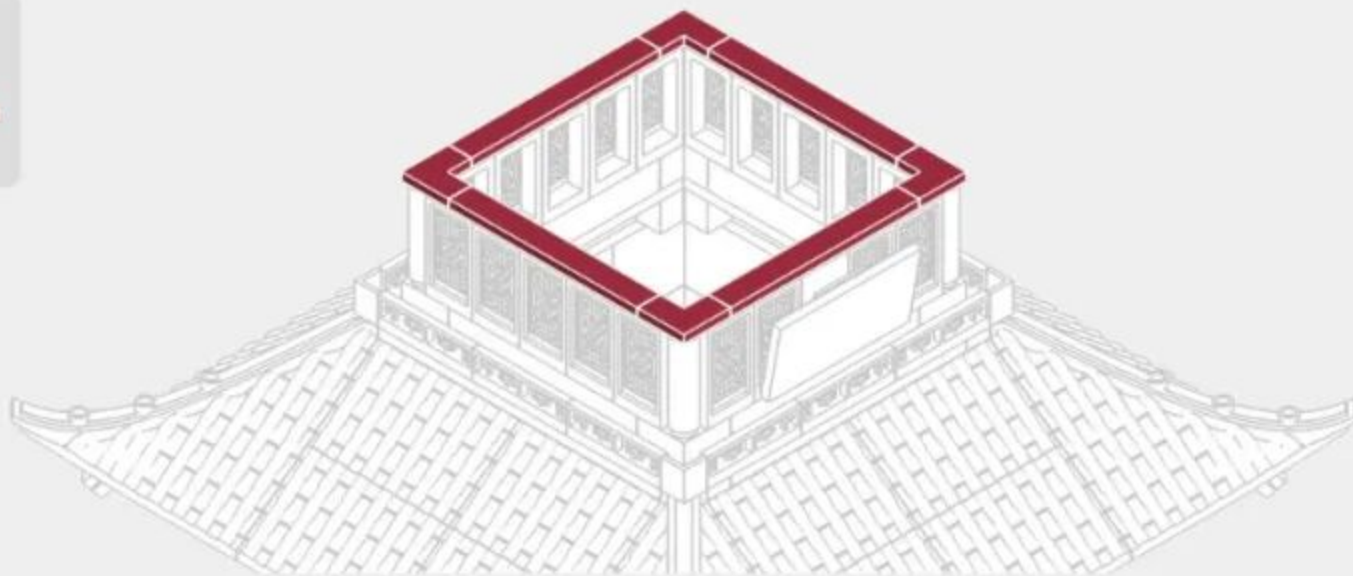

3-18

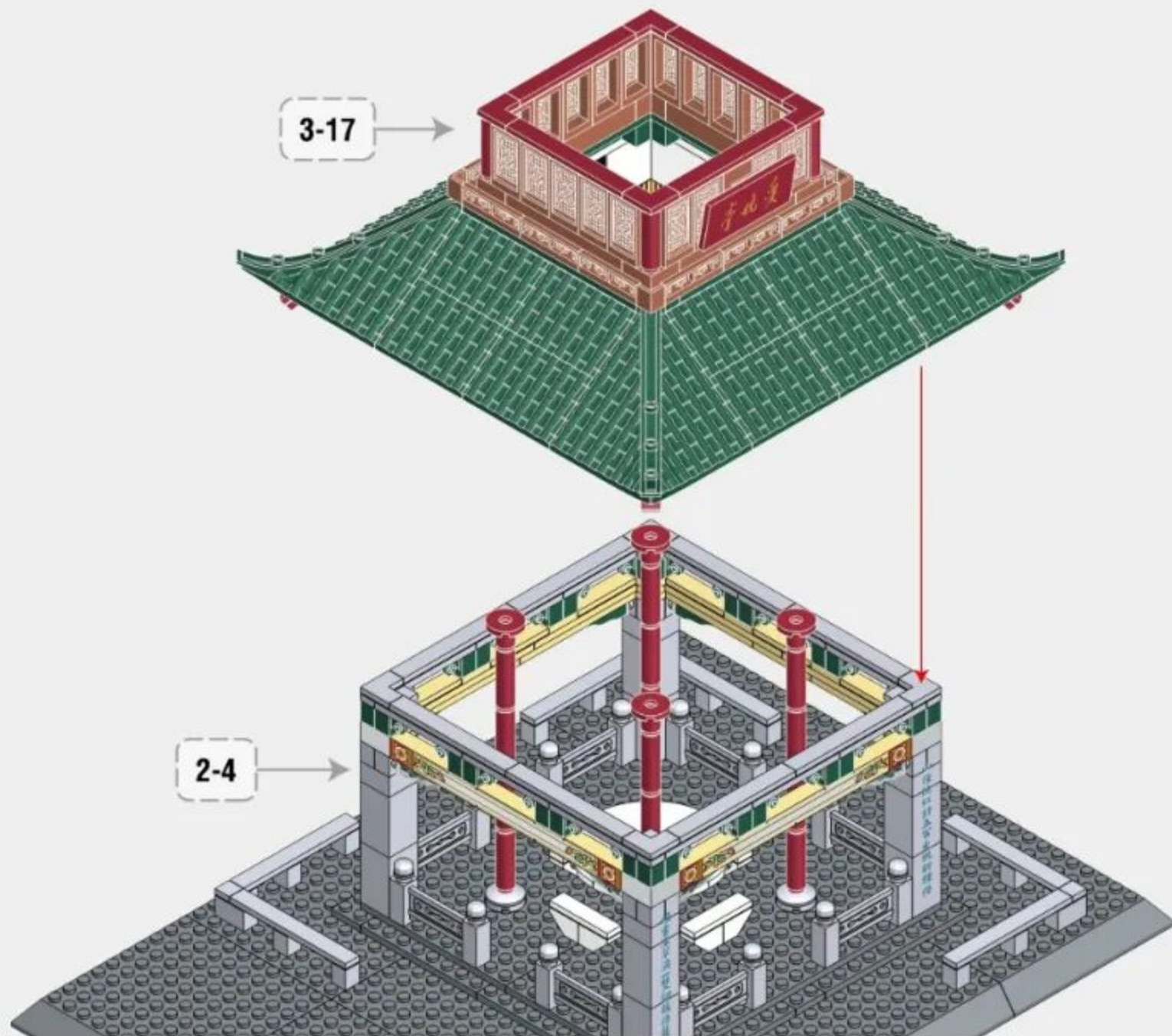

3-19

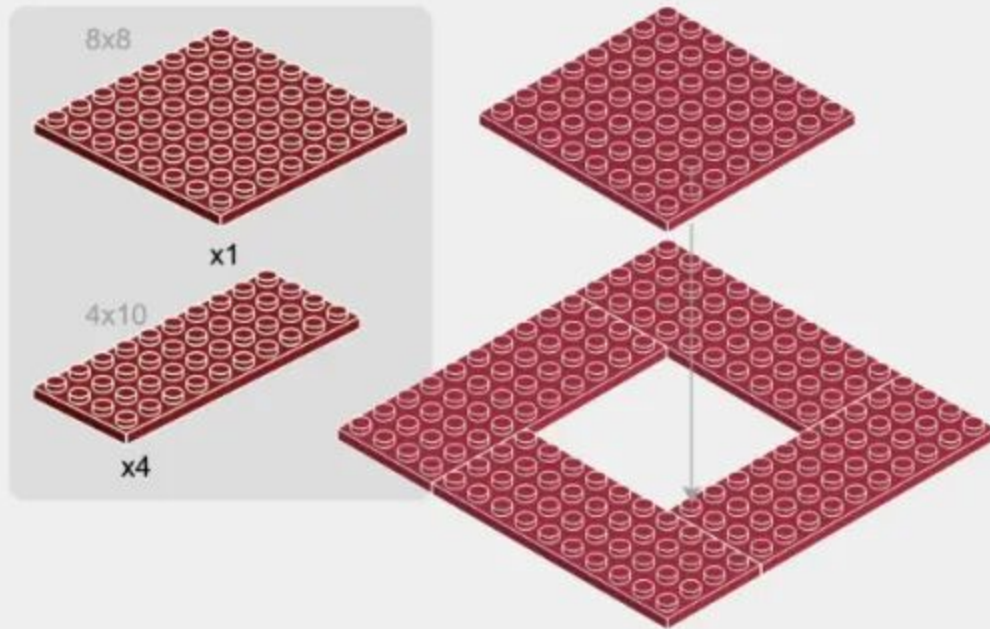

3-20

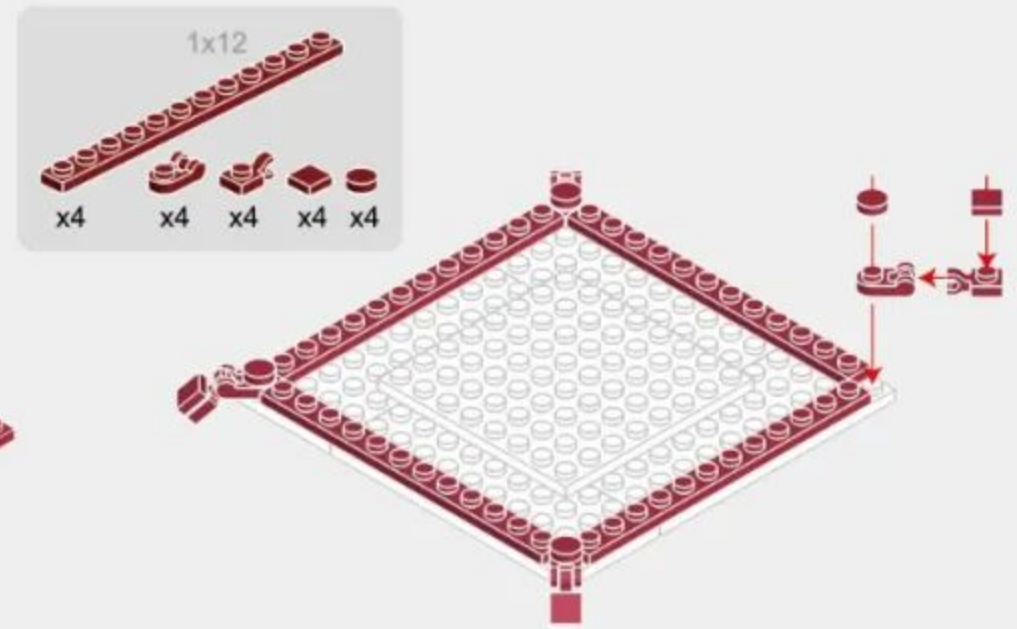

3-21

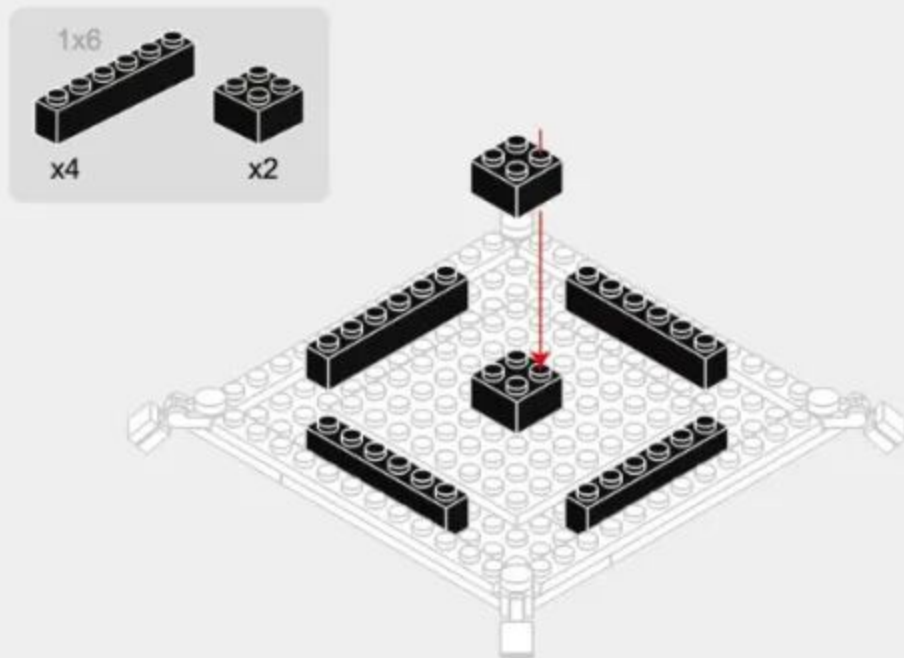

3-22

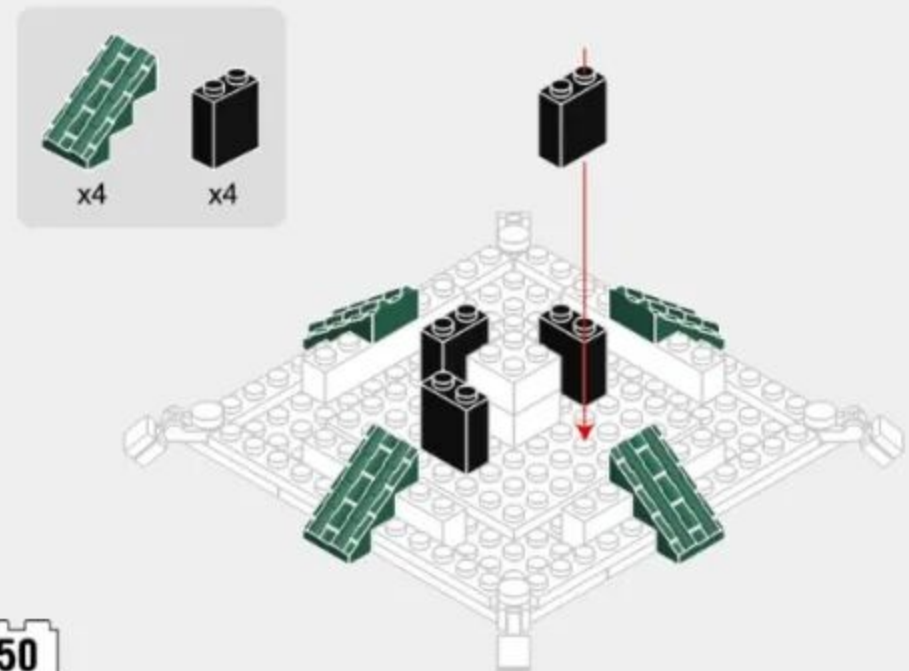

3-23

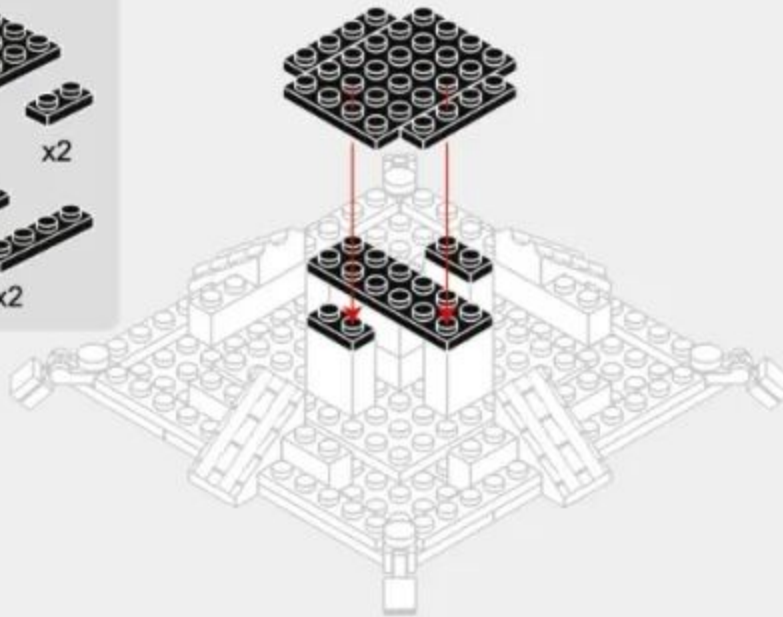
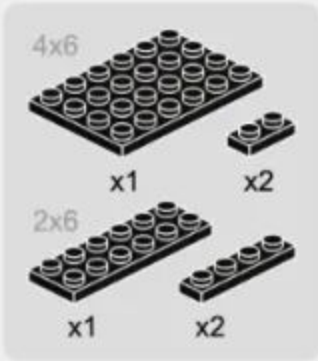

3-24

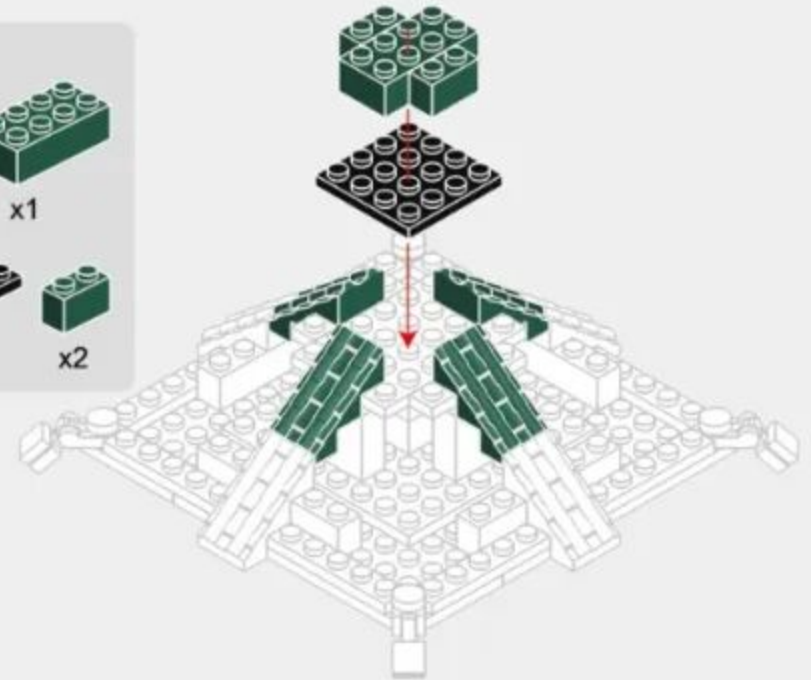
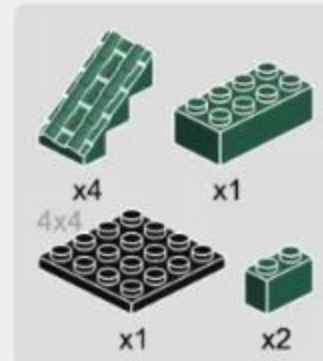

3-25

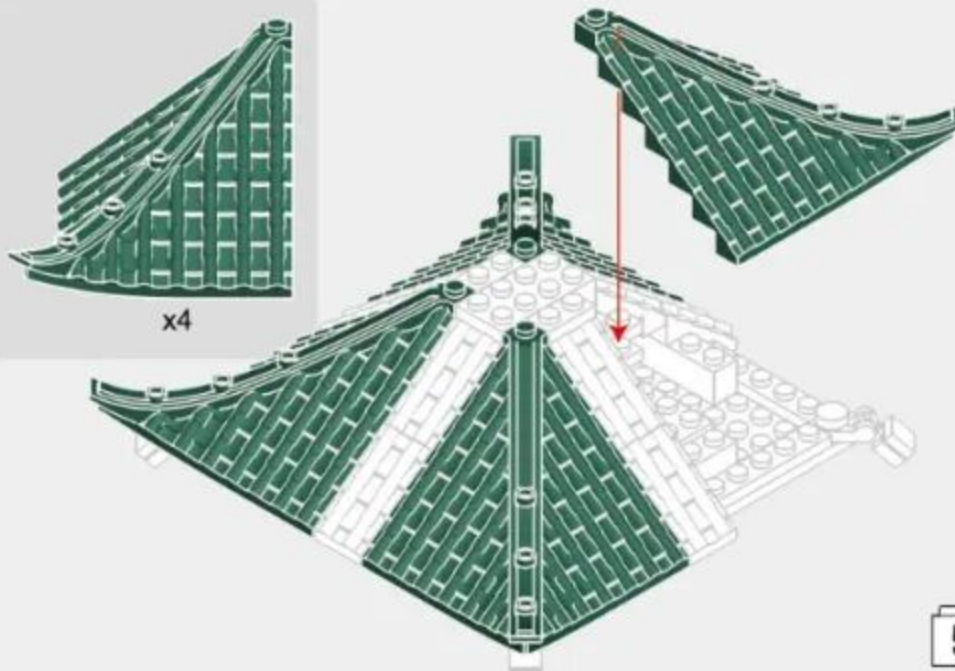
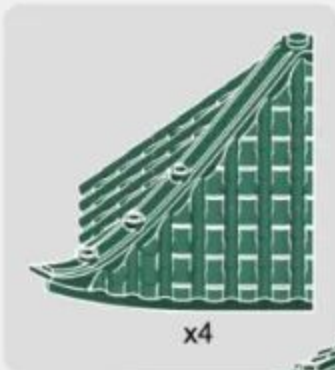

3-26

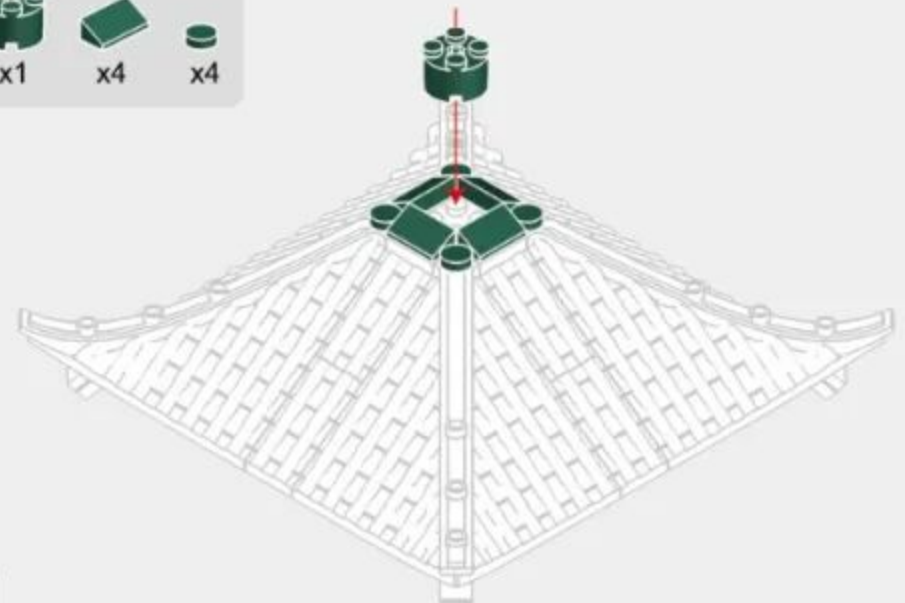

3-27

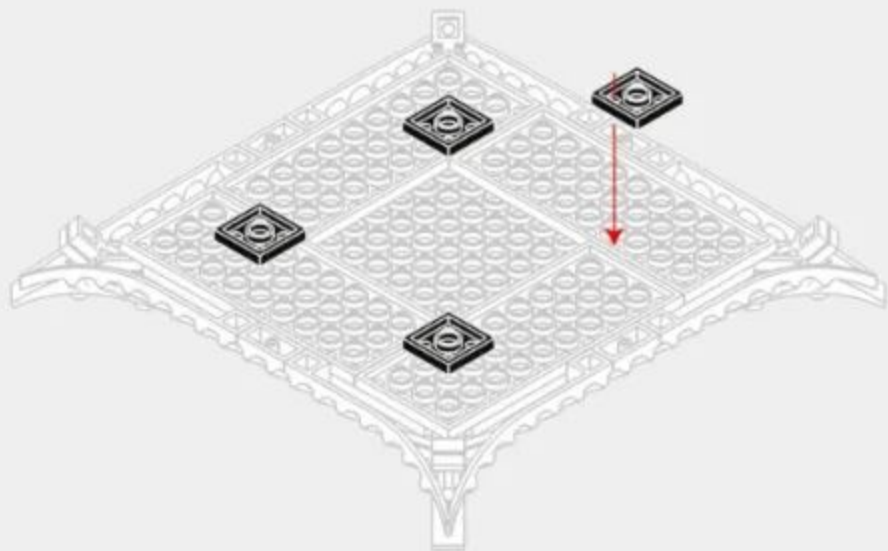

3-28

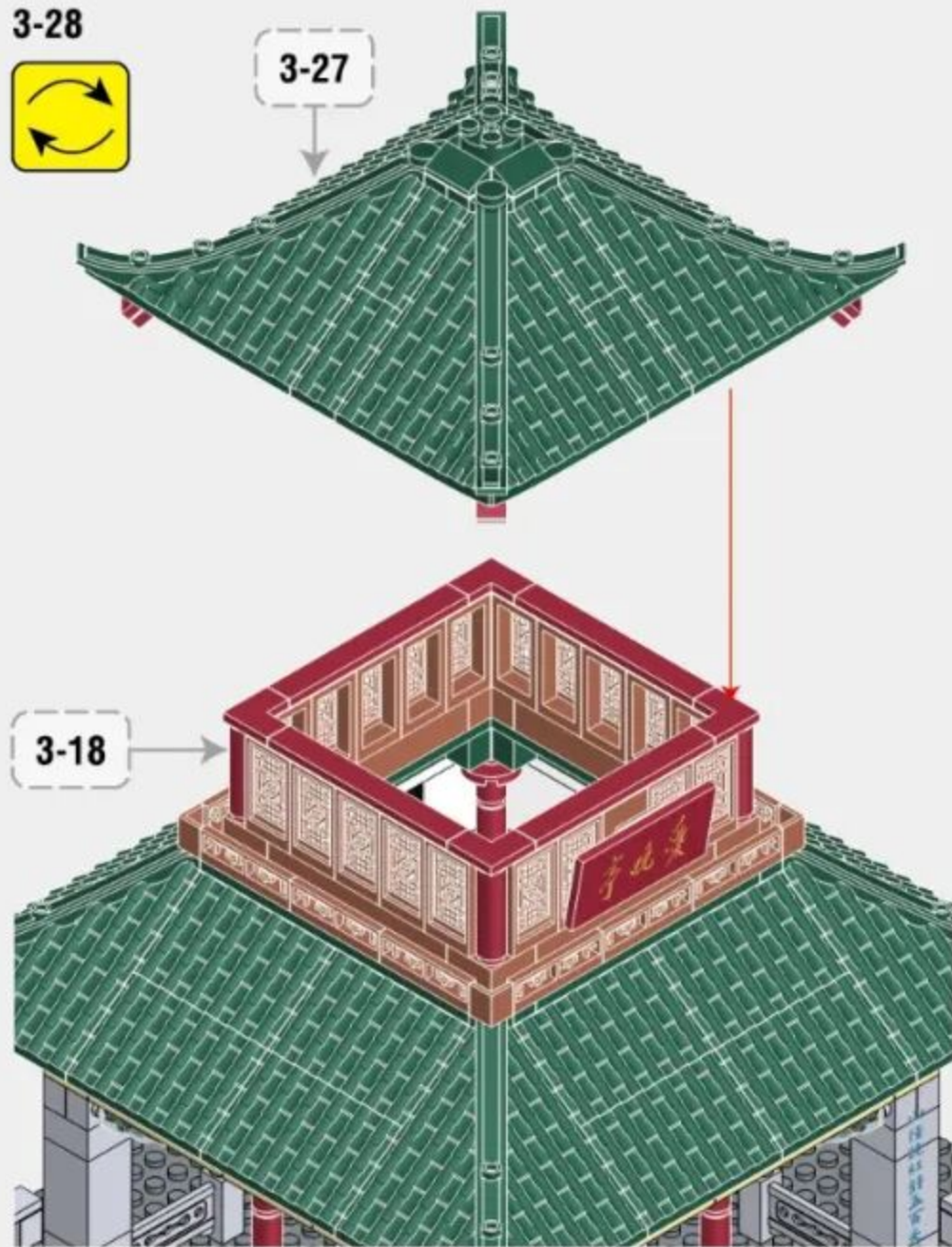

3-29

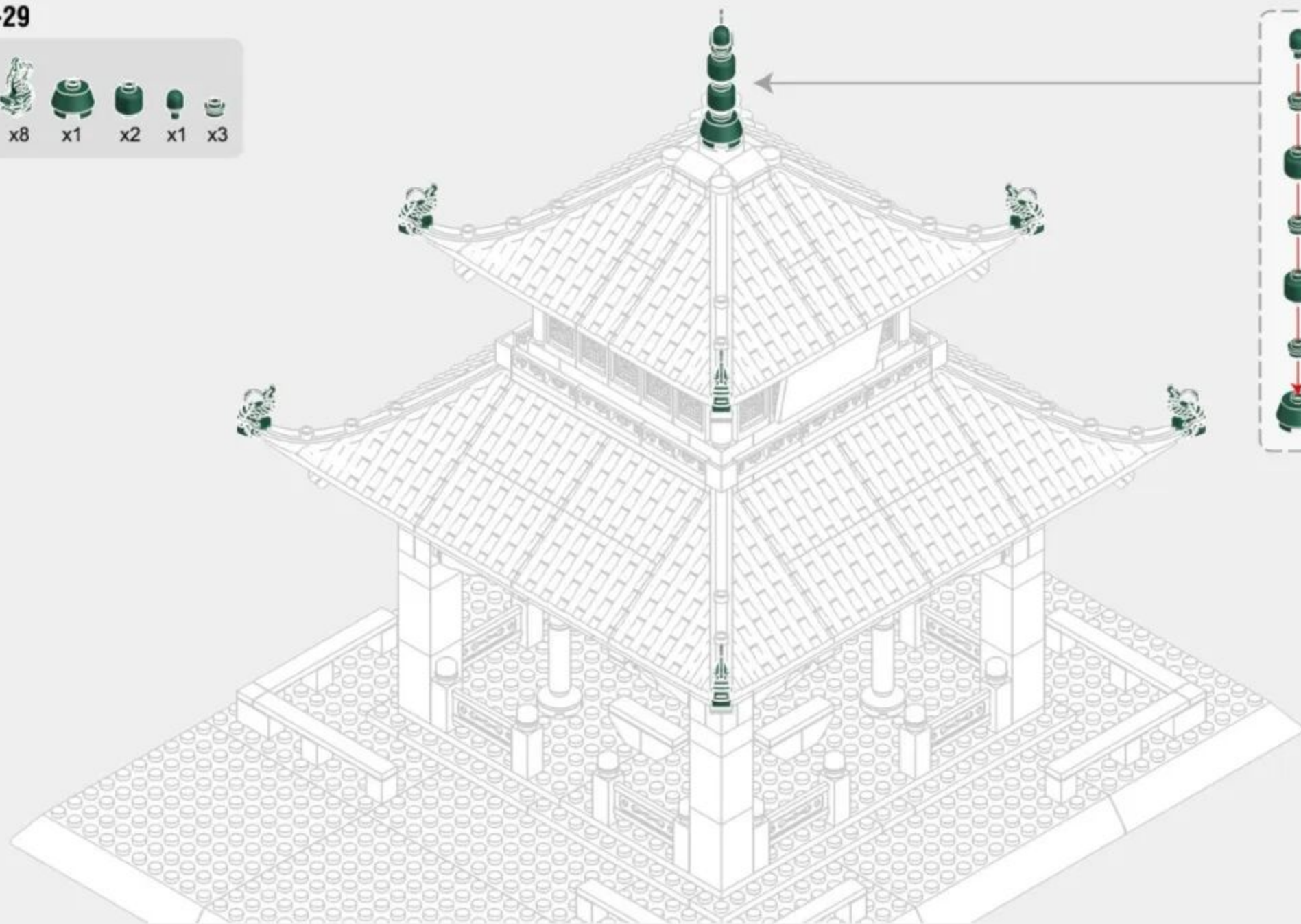



215PCS



54

4-1

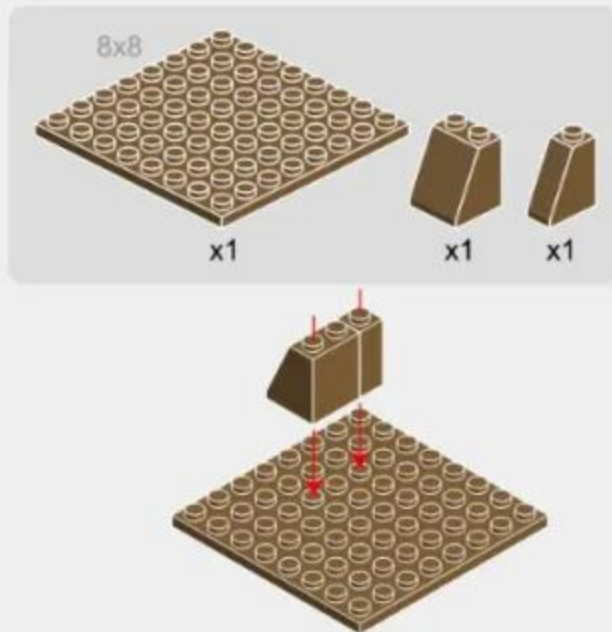

4-2

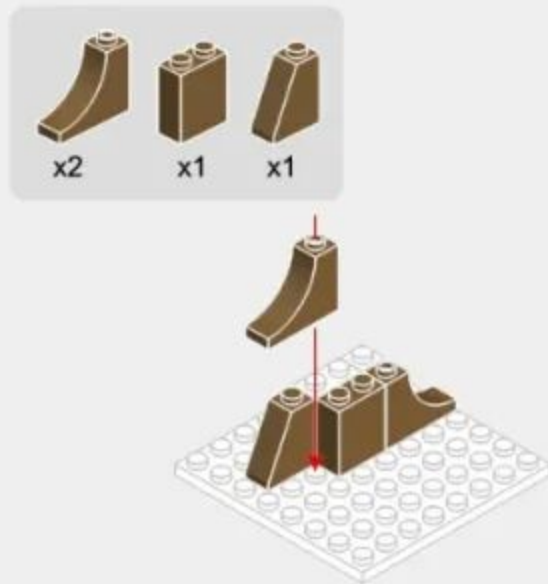

4-3

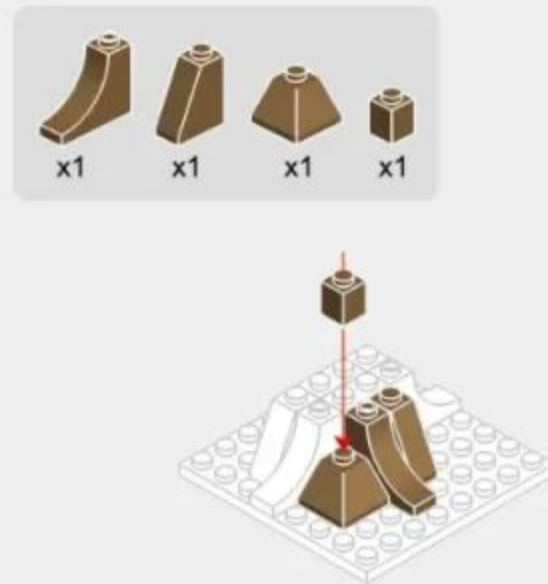

4-4

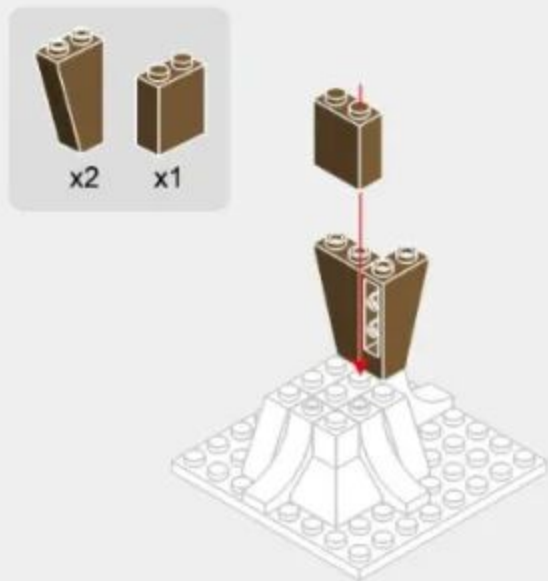

4-5

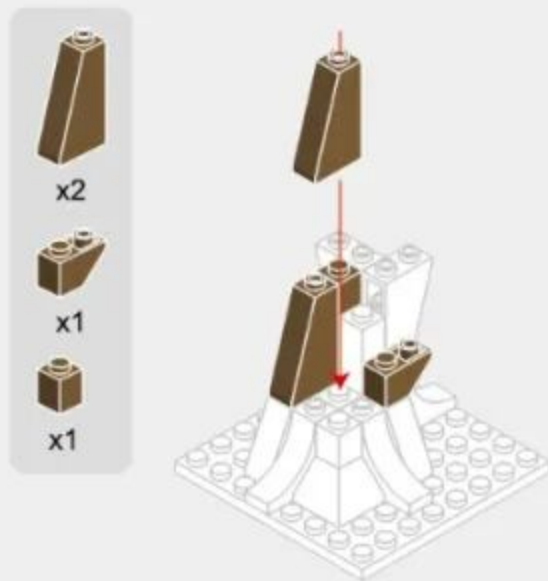

4-6

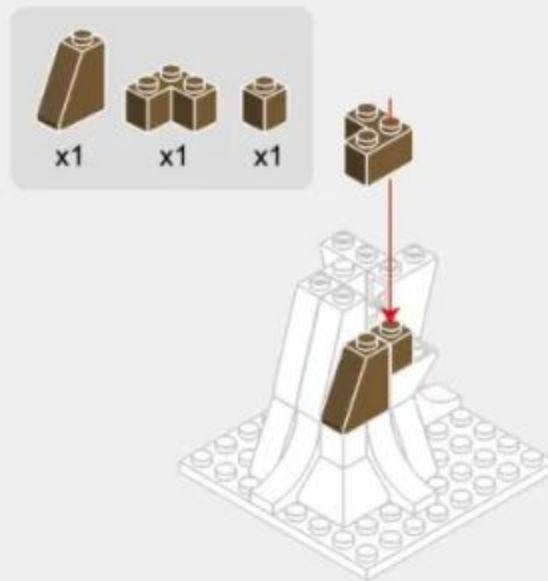

4-7

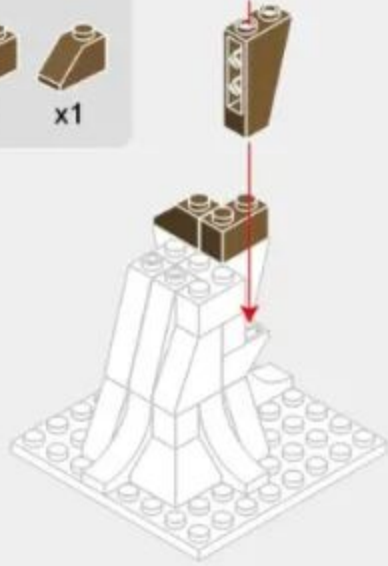

4-8

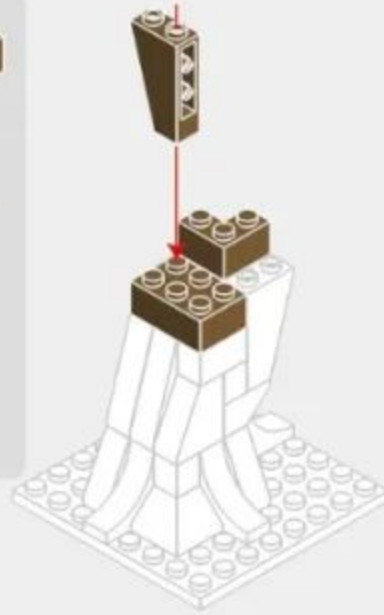

4-9

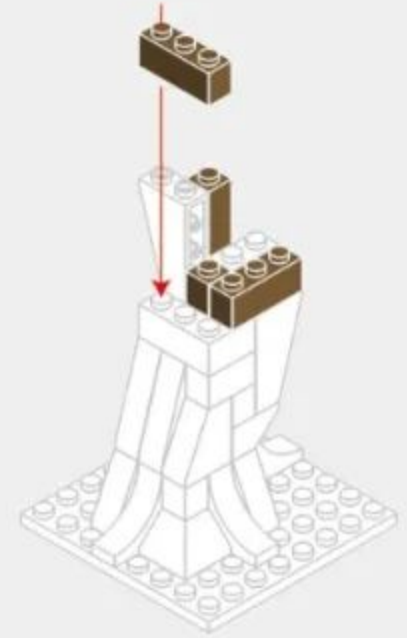

4-10



4-11

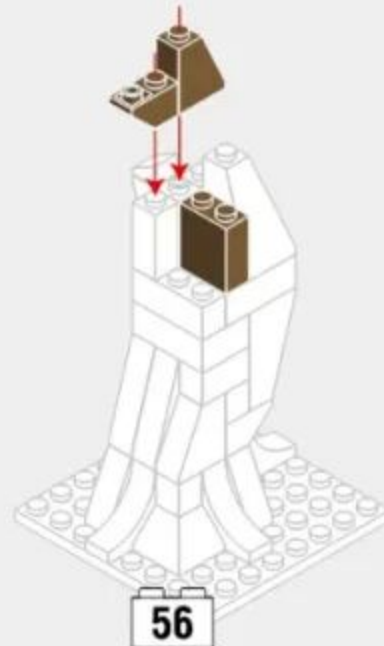

4-12

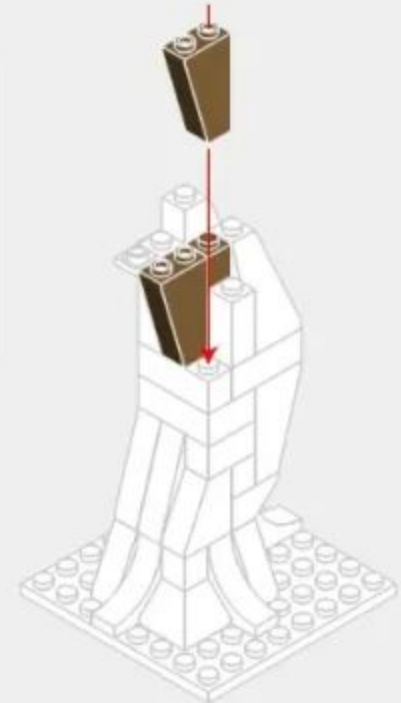

4-13

-  x1
-  x1
-  x1

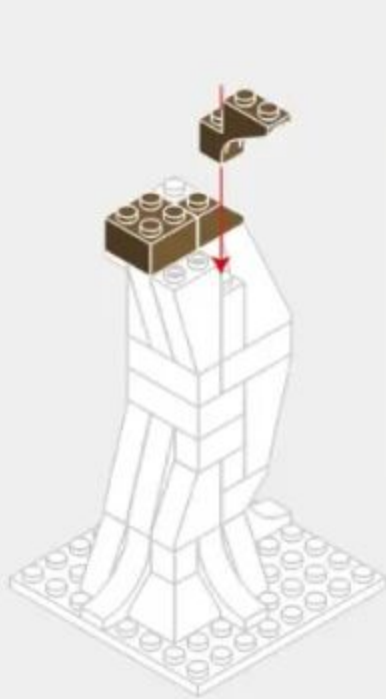

4-14

-  x1
-  x1
-  x1



4-15

-  x1
-  x1

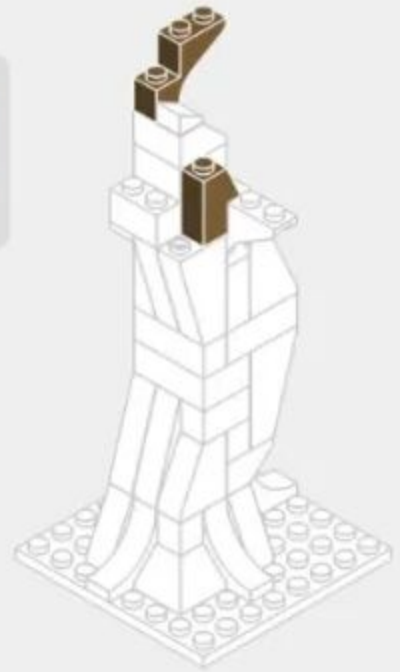

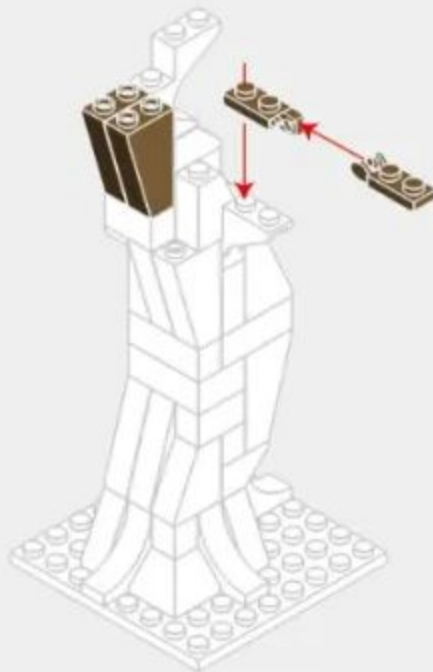

4-16

-  x2
-  x1
-  x1



4-17

-  x1
-  x1
-  x1
-  x1

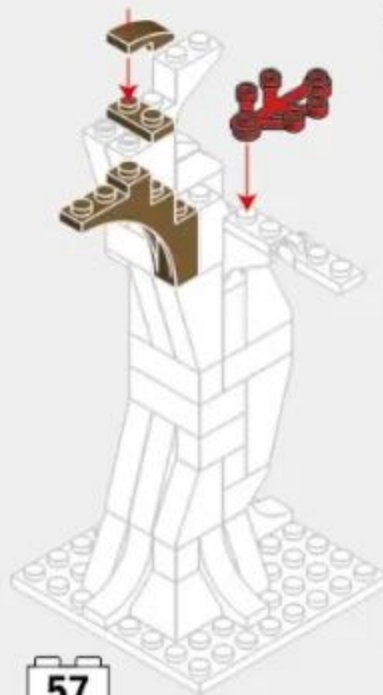

4-18

-  x1
-  x1
-  x1
-  x1
-  x1

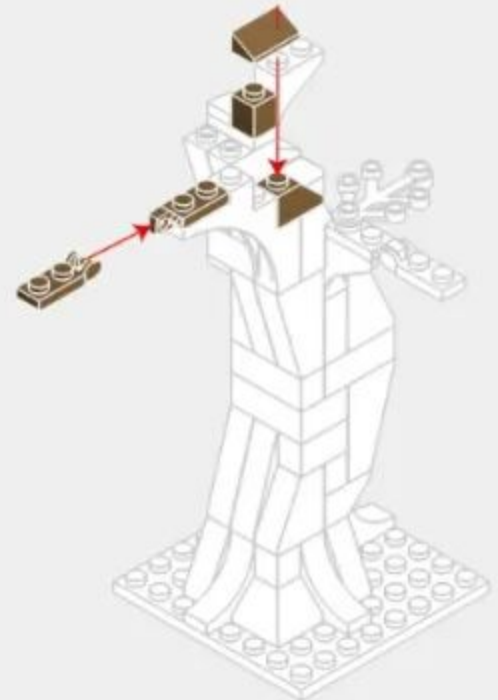

4-19

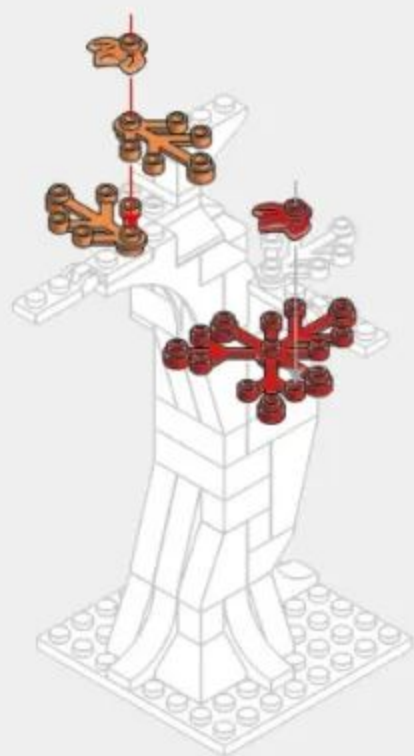

4-20

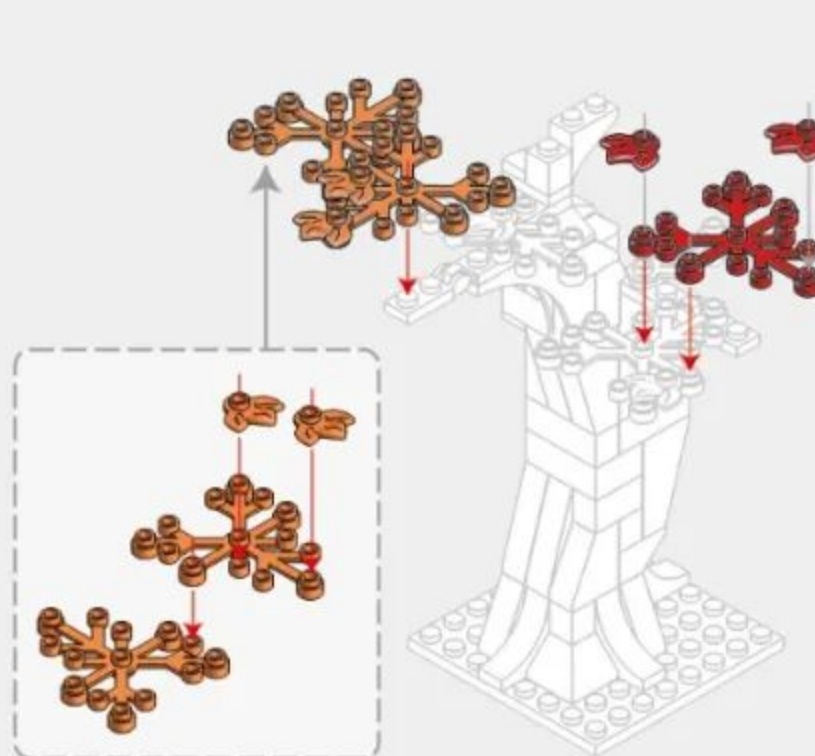
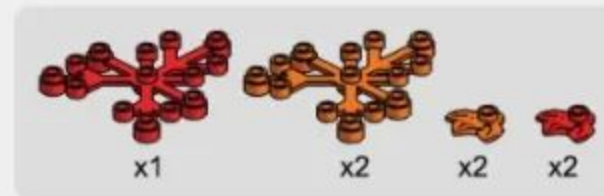

4-21

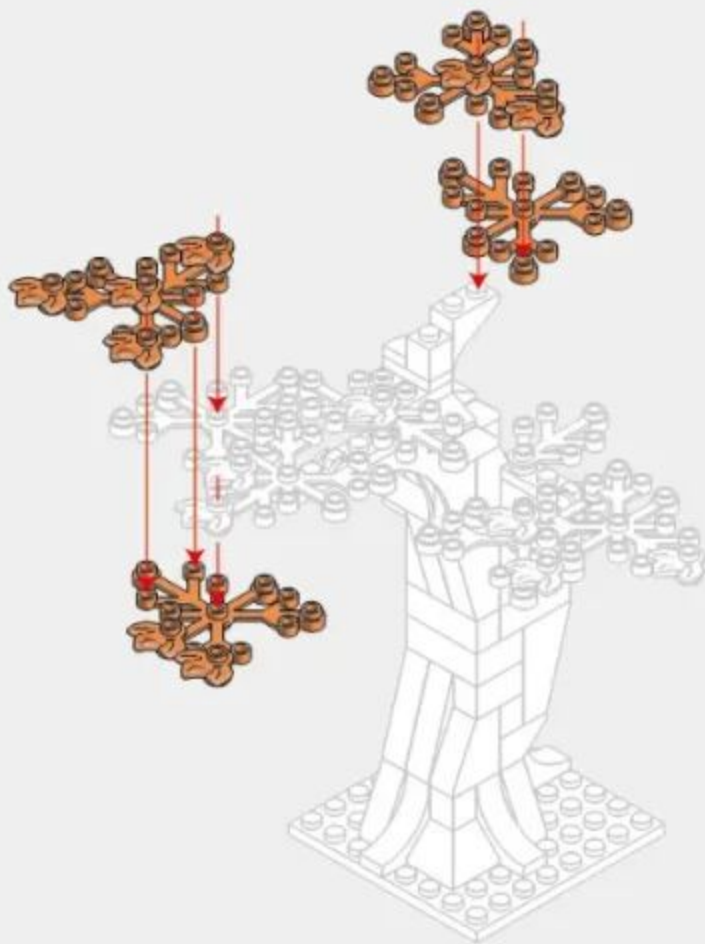
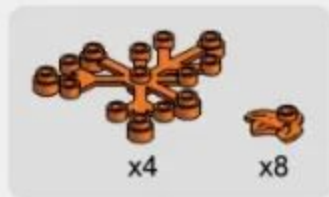

4-22

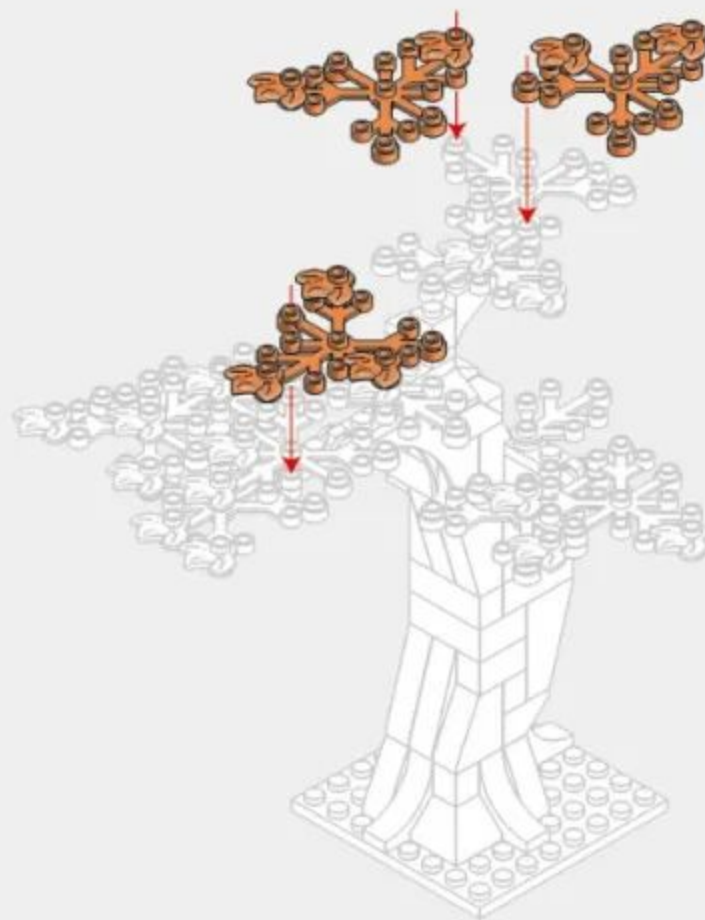
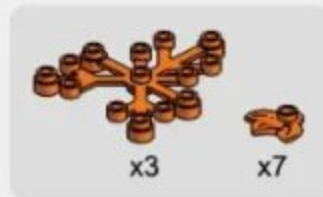

4-23

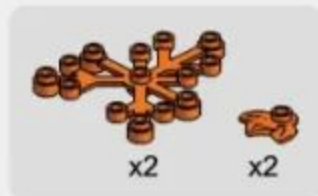

x2

x2



4-24

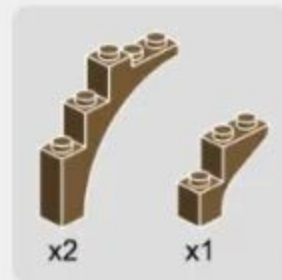

x2

x1

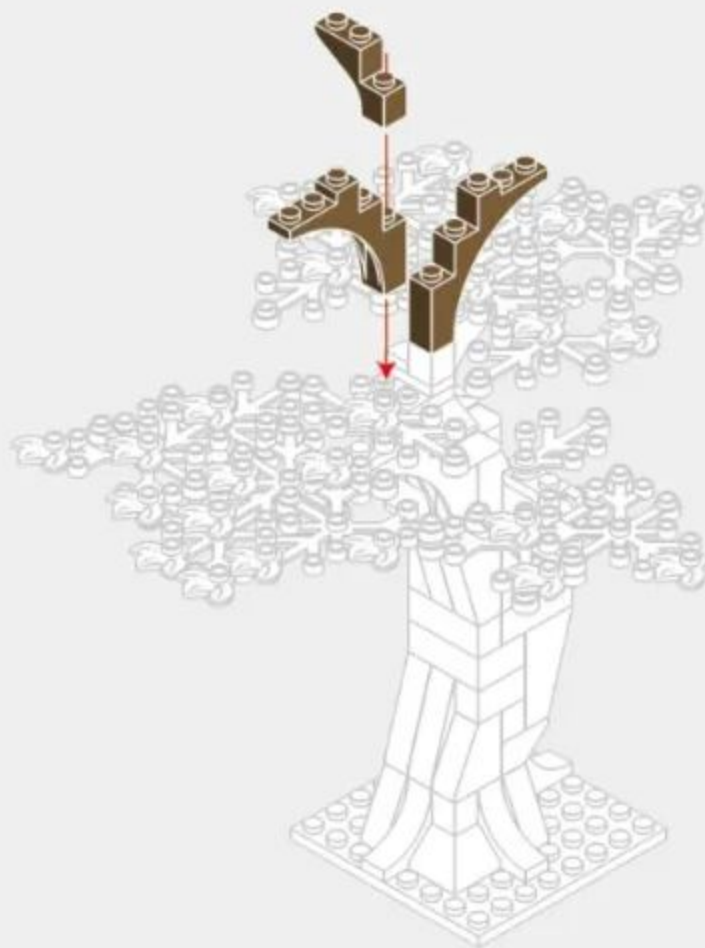

4-25

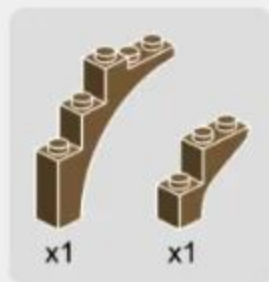

4-26



4-27



x1 x1 x1 x1 x2



4-28



x1 x1 x1 x1 x3

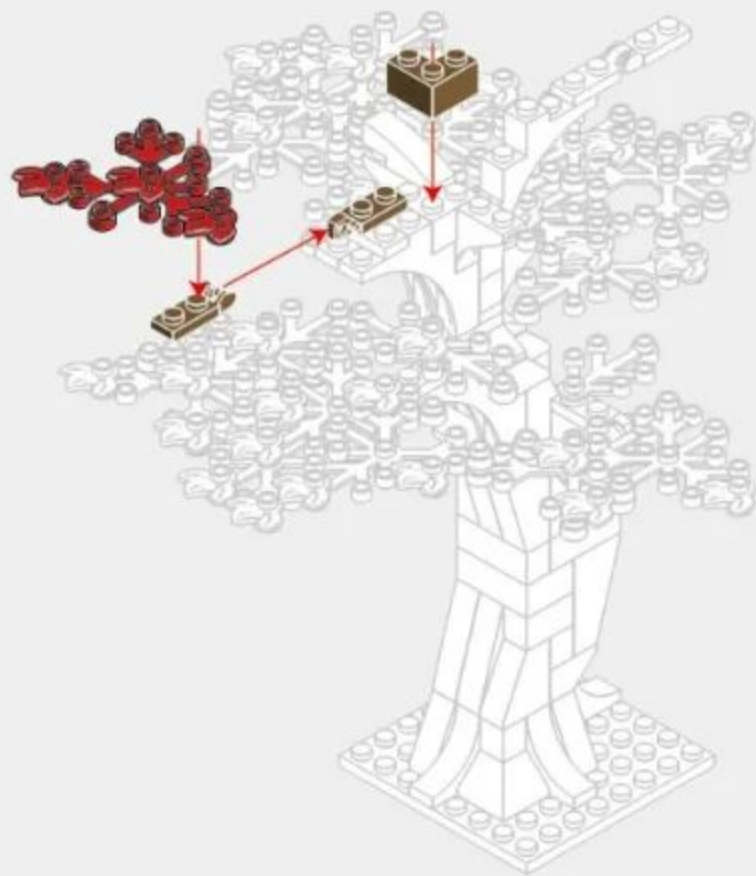

4-29

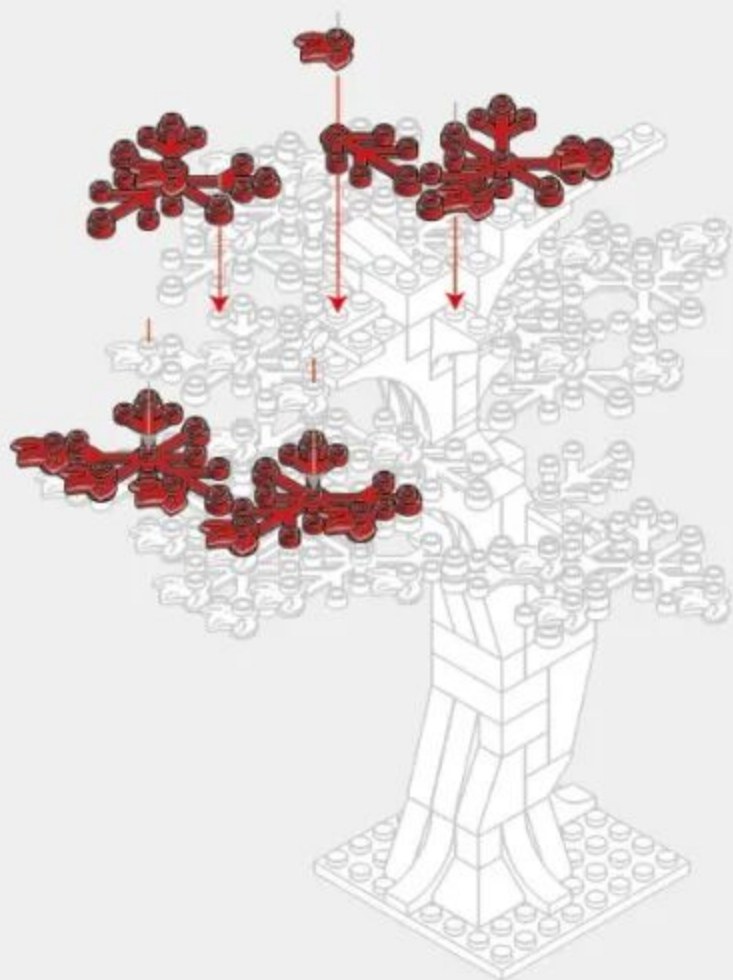
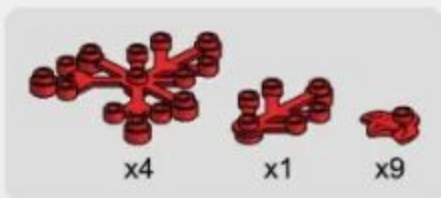

4-30

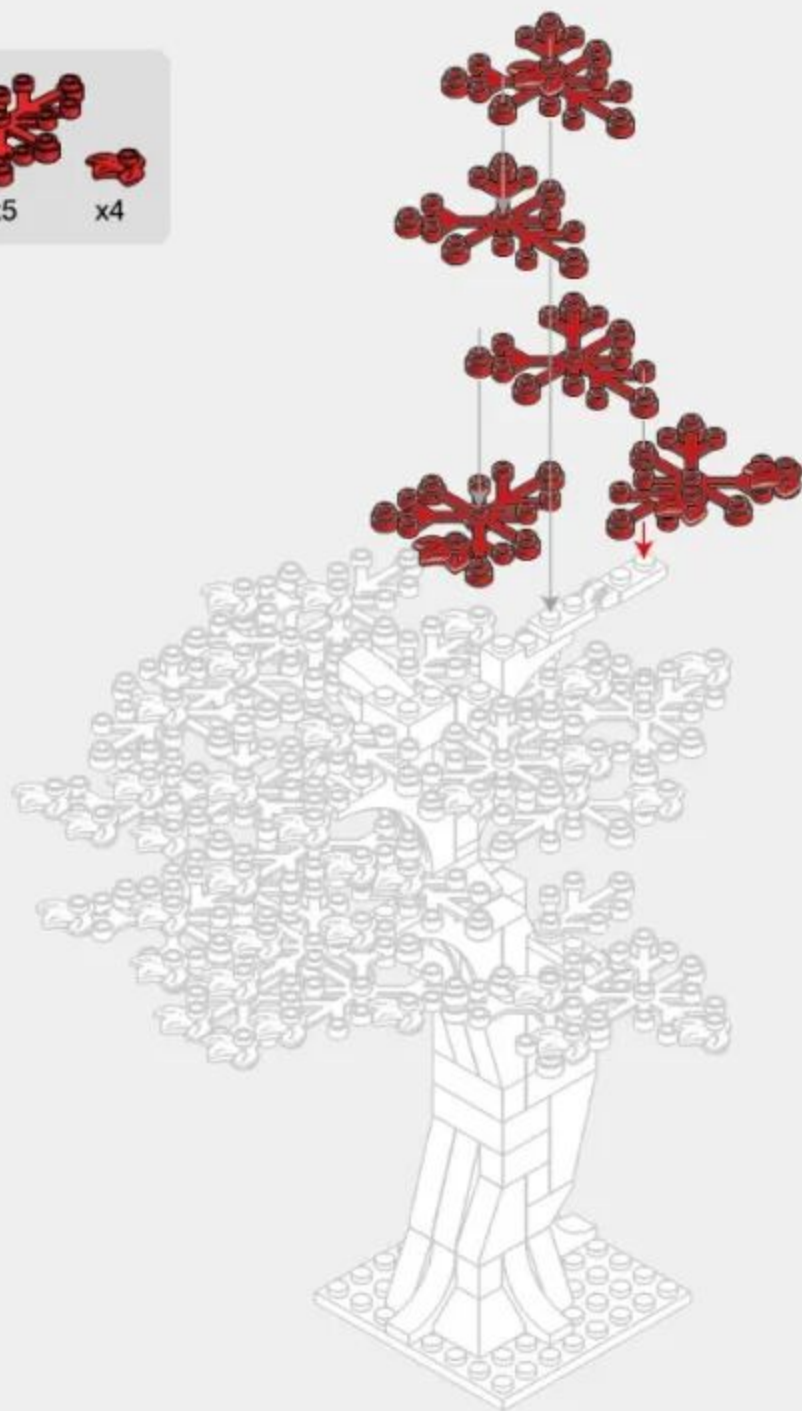
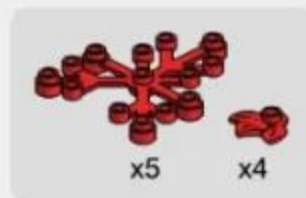

4-31

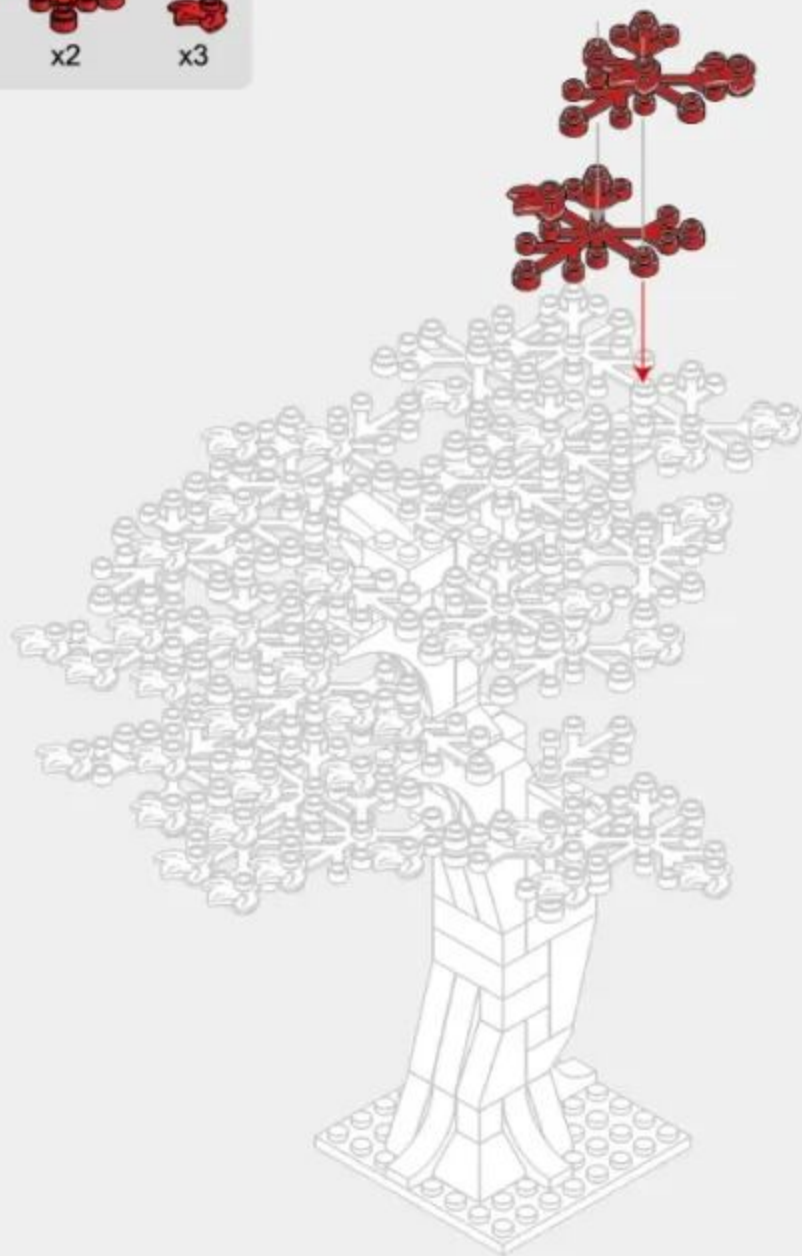
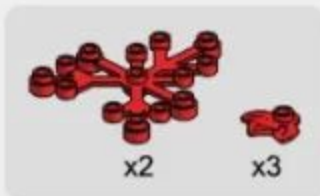

4-32

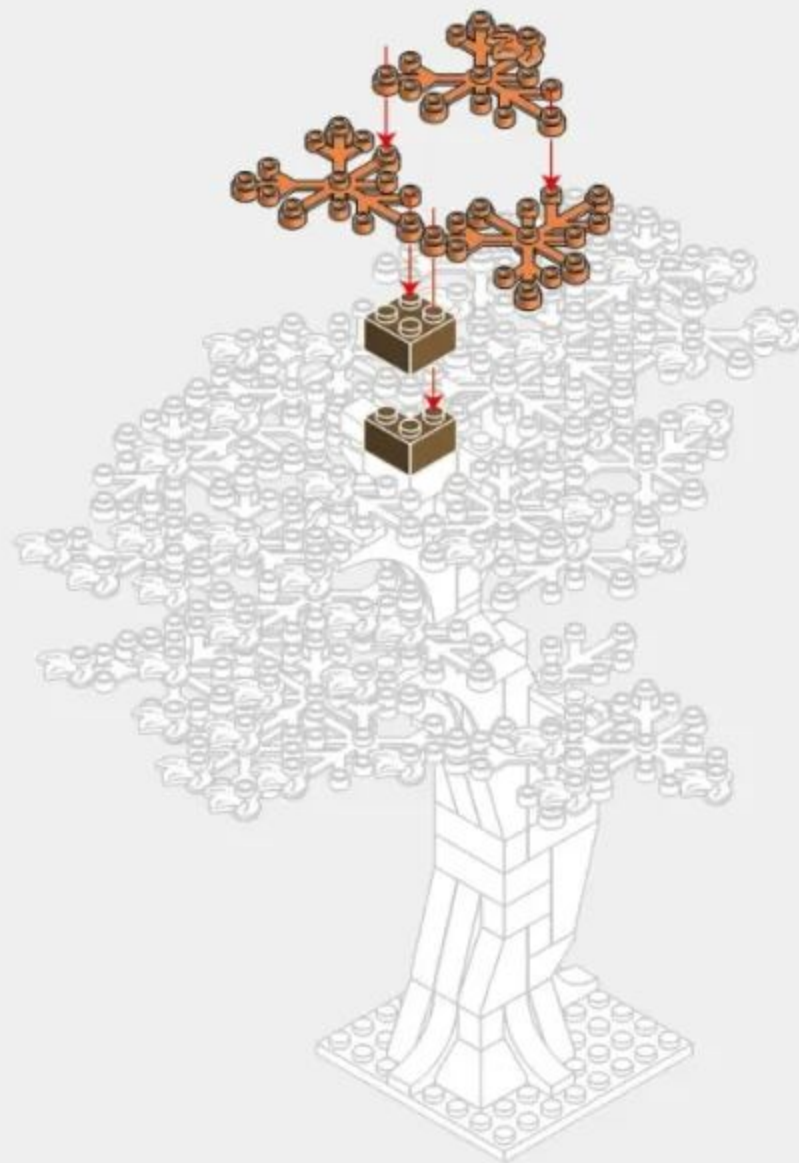

4-33

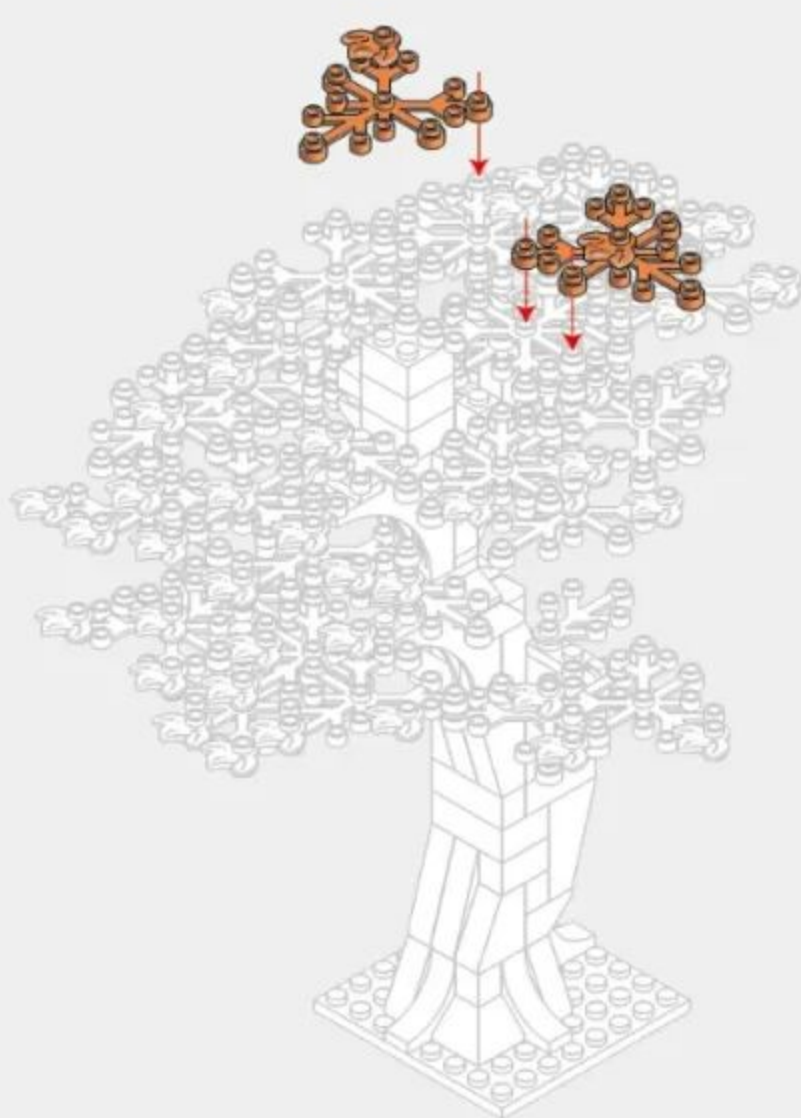
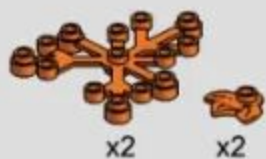

4-34

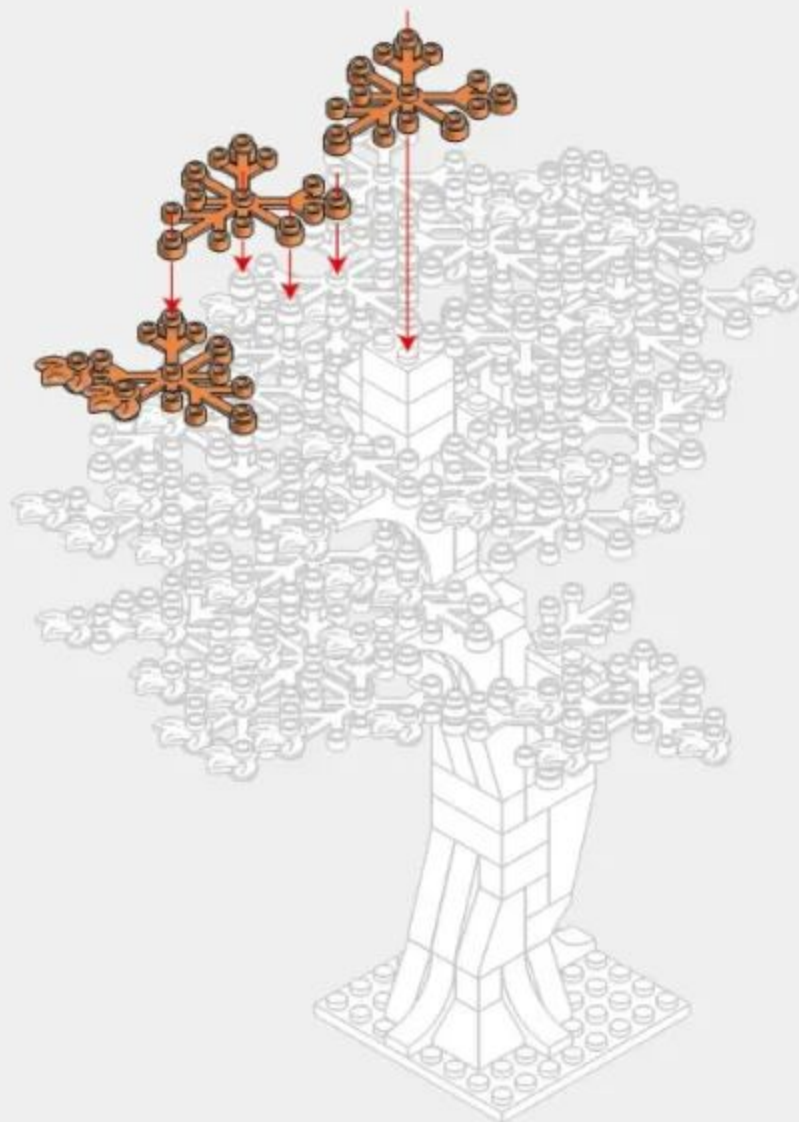
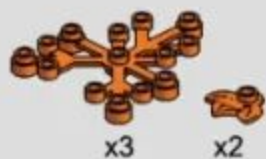

4-35

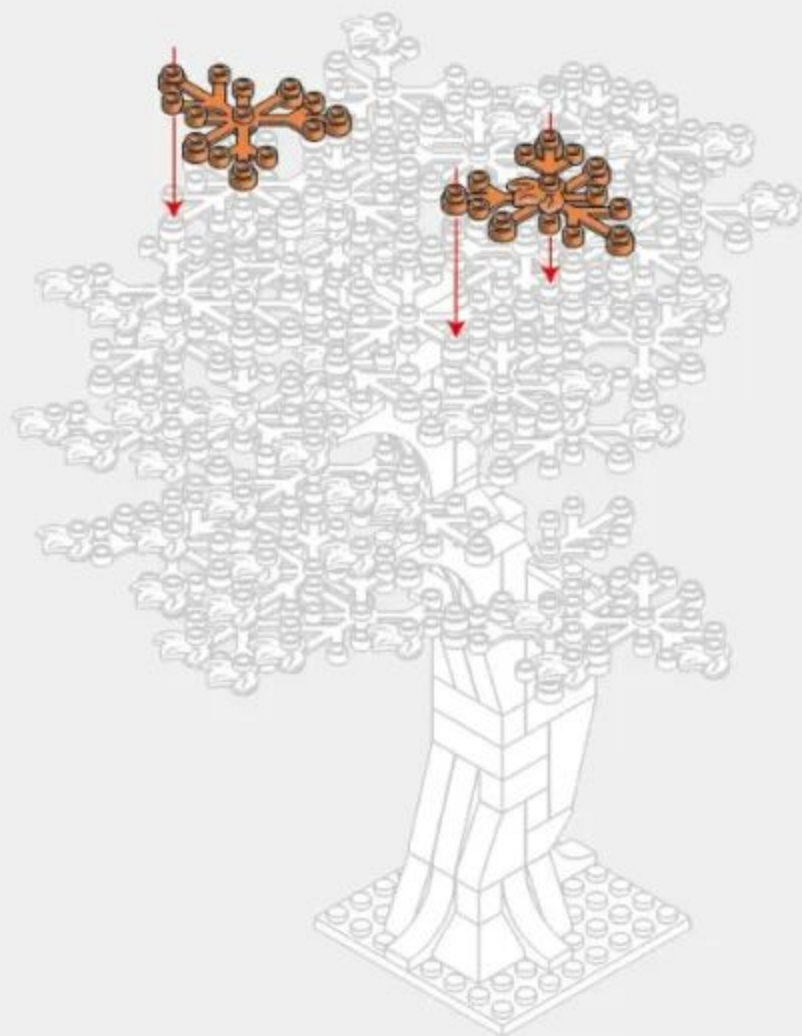

4-36

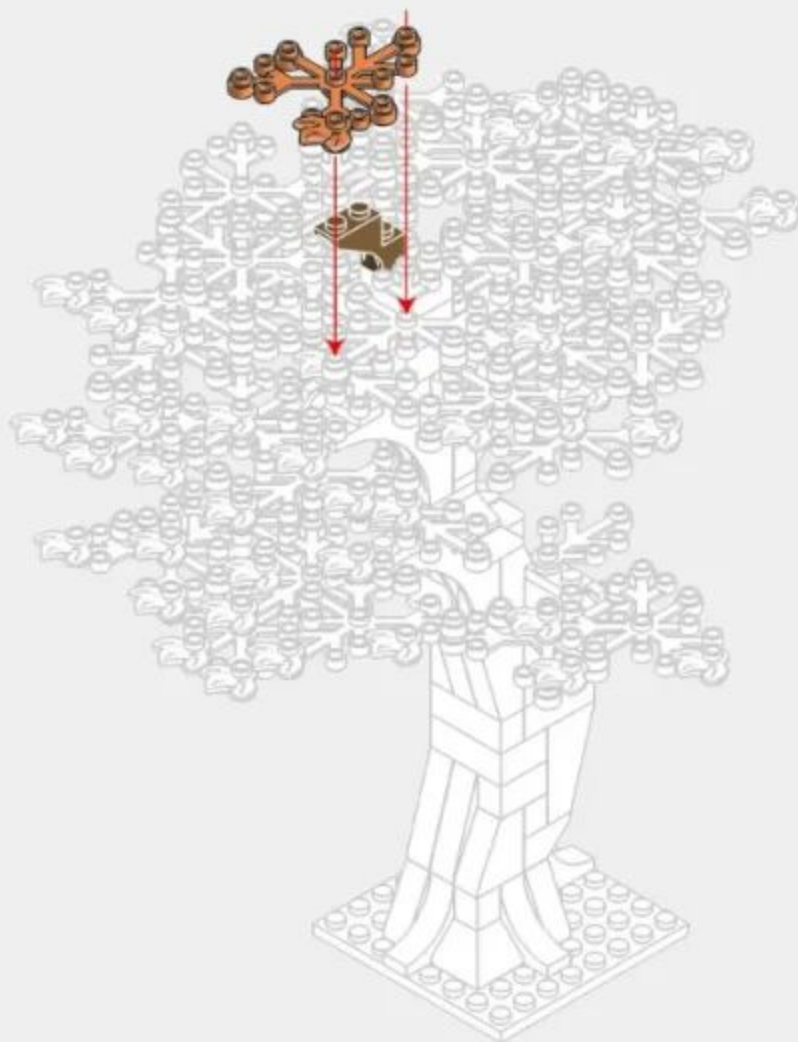
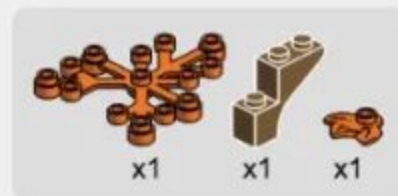

4-37



x2

x3

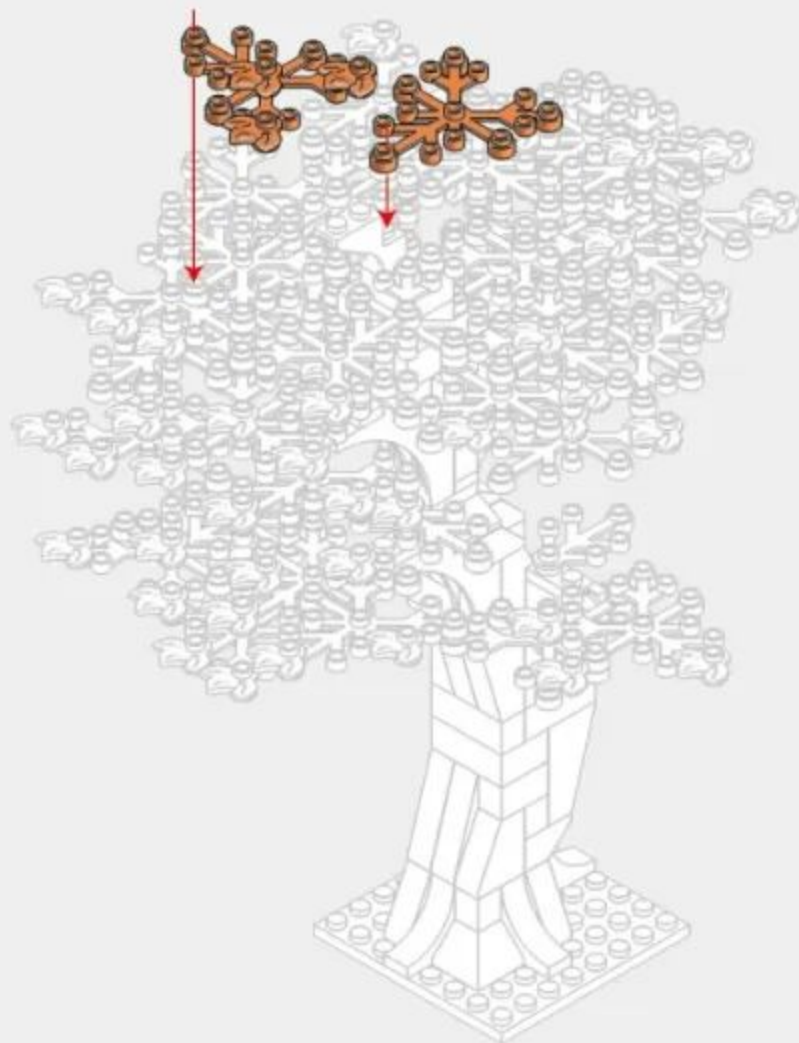

4-38



x1

x2

x2

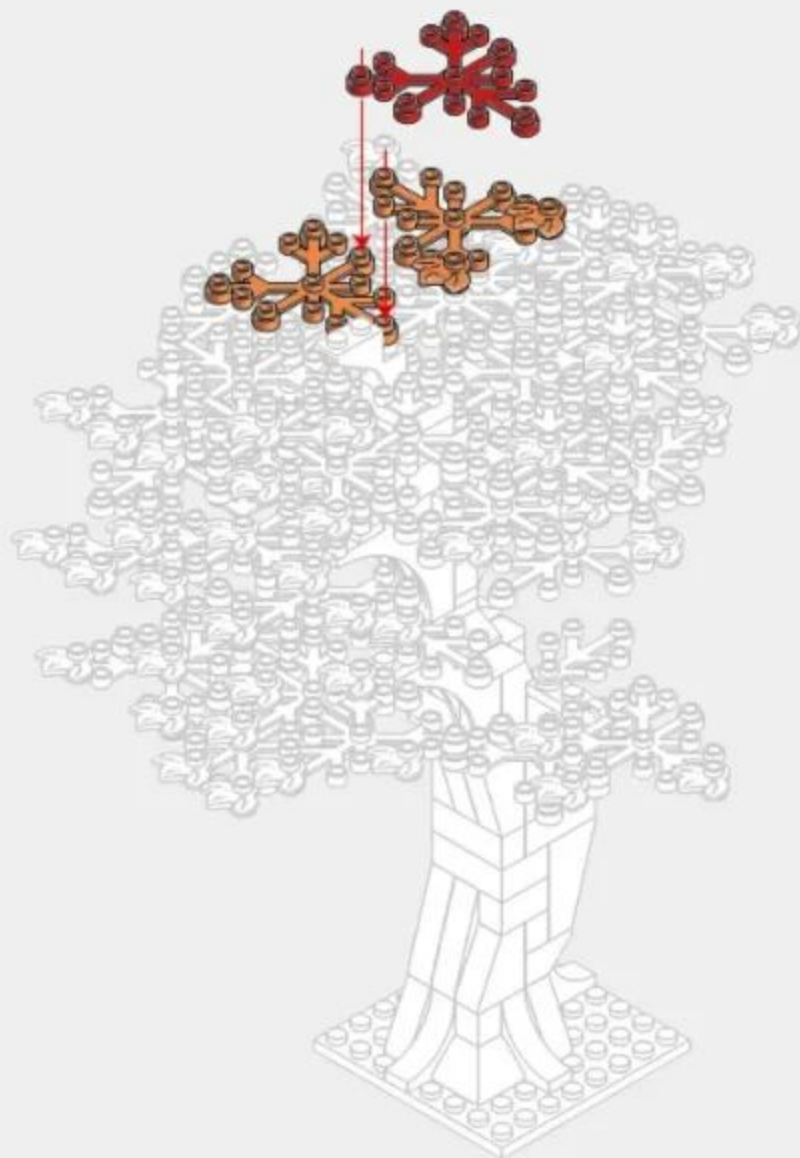

4-39



x1

x1

x2

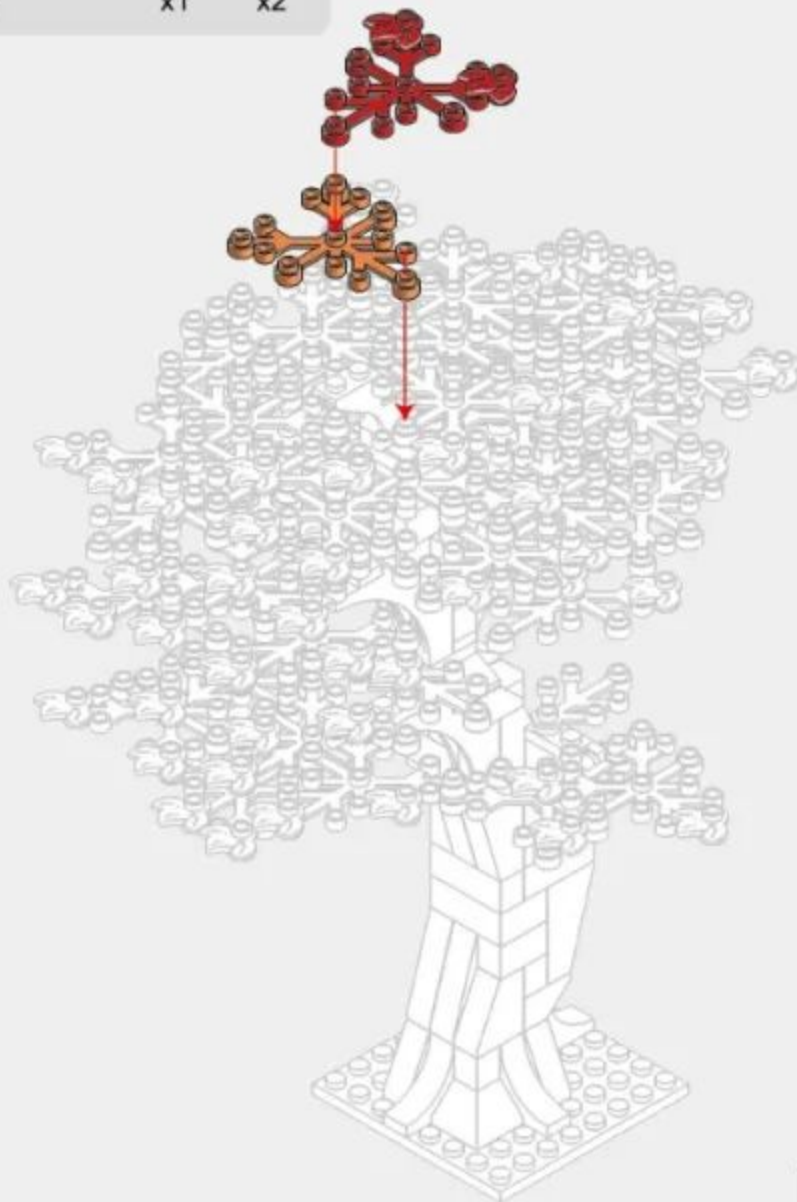

4-40



x2

x4

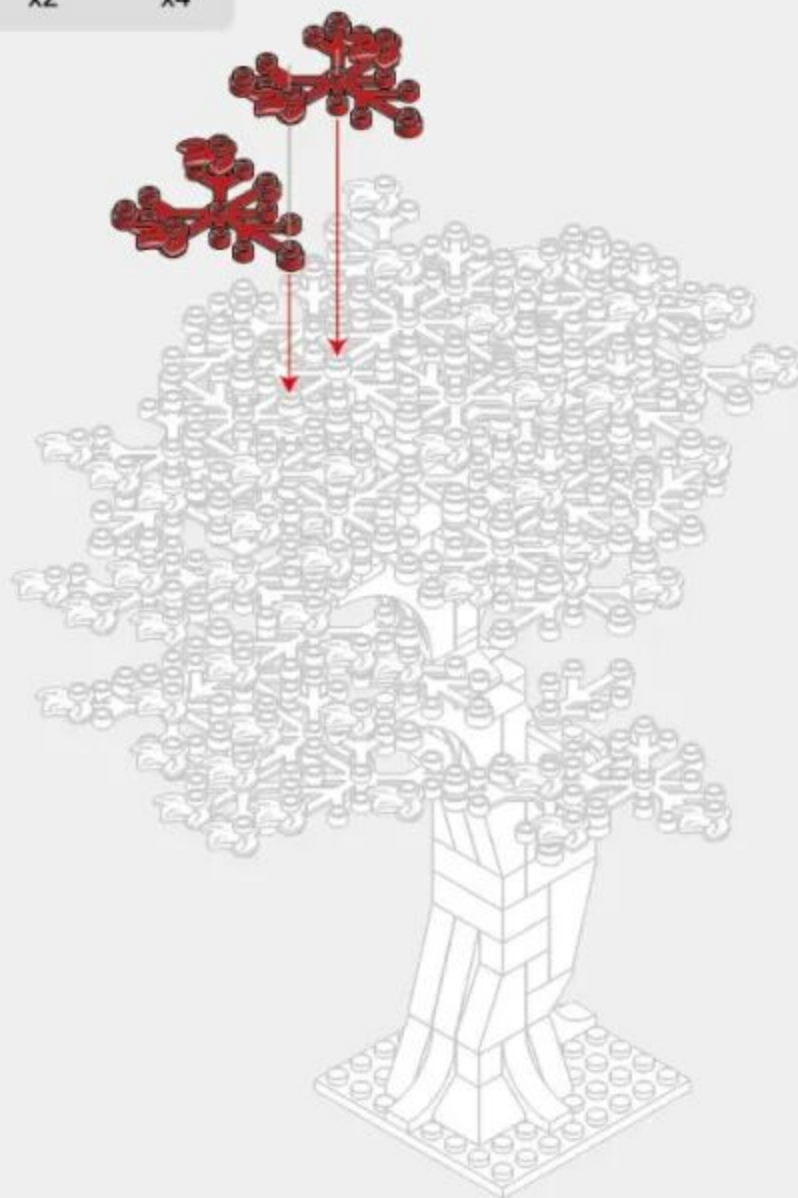

4-41

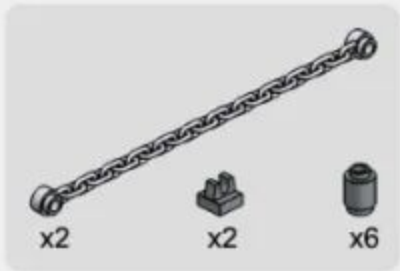

4-40

3-29

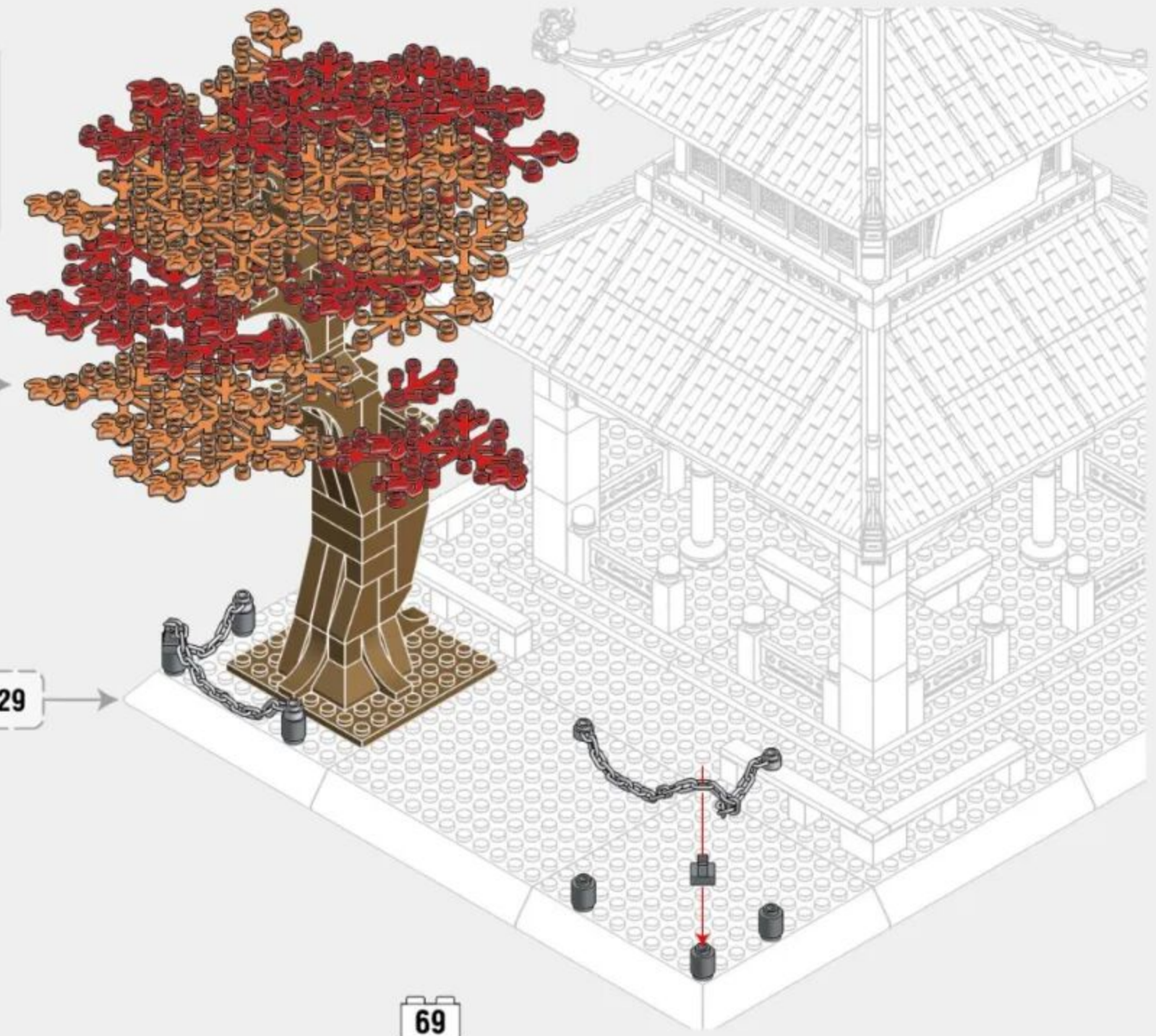

4-42

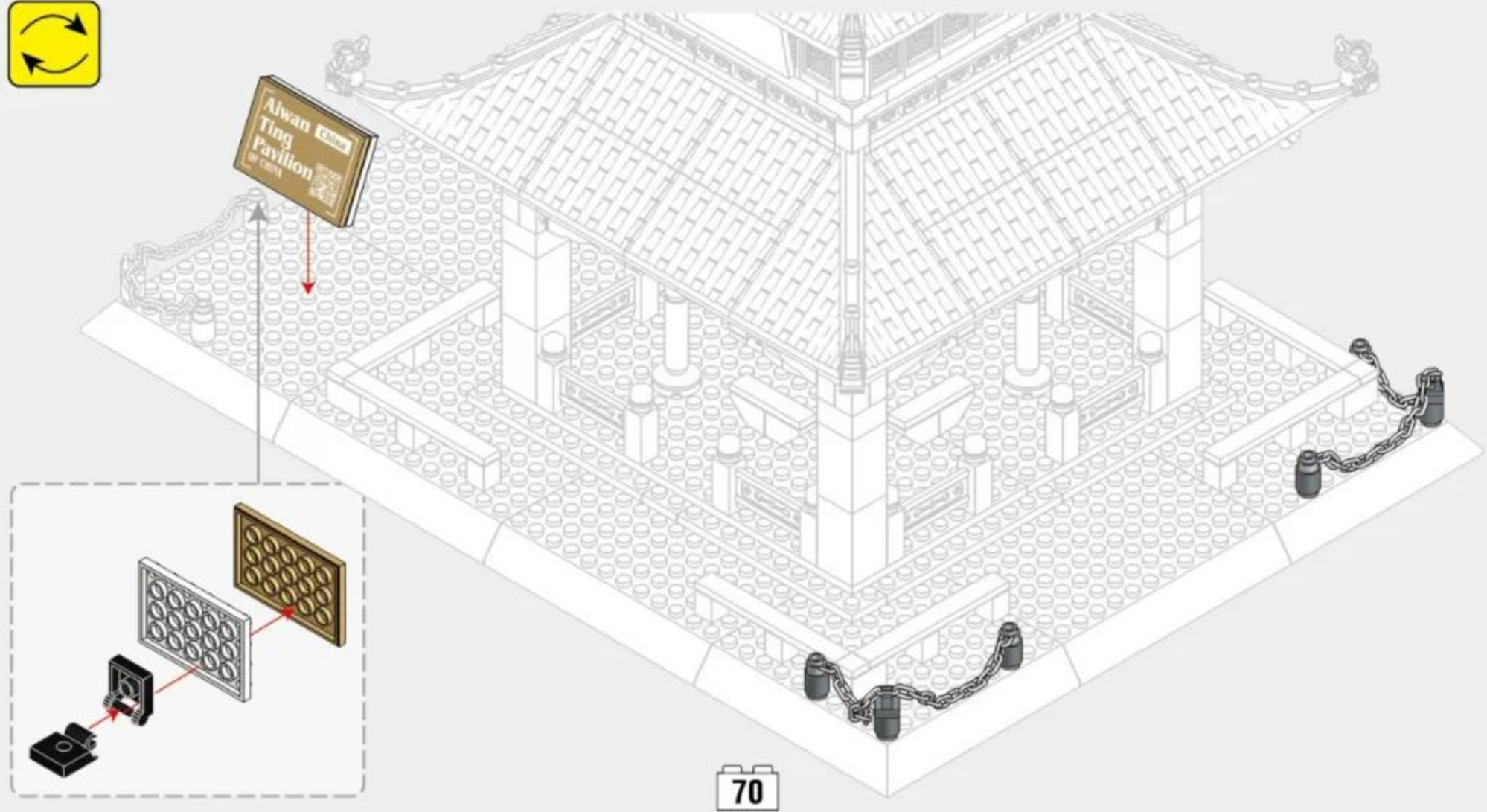
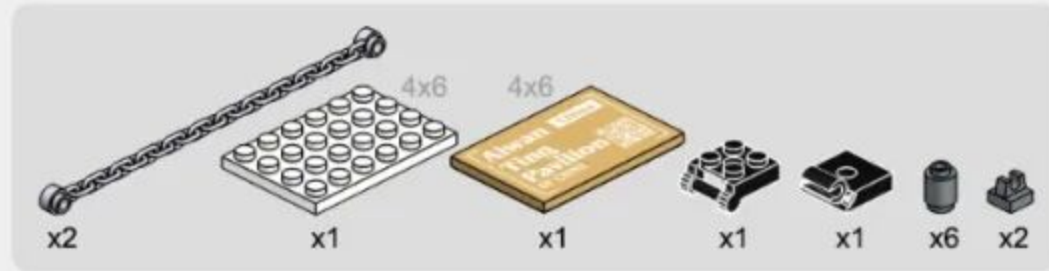



AIWAN TING PAVILION

COUNTRY: China

CITY: Changsha



Ver.5230210831