



CHRIST THE REDEEMER

CRISTO REDENTOR

Rio de Janeiro, Brazil

The world's great architecture



Creative Ability

Family Interaction

Observation Ability

Thinking Ability

Practical Ability



6+
Suitable Age

5231
Product Number

973PCS
Parts Total



Architecture

It will be a city...

这将构成一座城市...

ABOUT THE PRODUCT

关于产品



ARCHITECTURE

WANGE The world's great architect since 1991

Christ the Redeemer



This statue is located on the top of Corcovado Hill, 700 meters (2,300 feet) in Tijuca Forest National Park, overlooking the city of Rio de Janeiro.



Christ the Redeemer



Geography and culture

地理·文化



Christ the Redeemer
(Portuguese: Cristo Redentor, standard Brazilian Portuguese local pronunciation is an Art Deco statue of Jesus Christ in Rio de Janeiro)





Christ the Redeemer

Christ ■ the Redeemer

Brazil

The contents of this chapter refer to the Wikipedia website.

本章内容参考维基百科网站，更多资讯可自行查阅。

The world's great architecture

Buildings and layout

■ 建筑物和布局



Christ the Redeemer (Portuguese: Cristo Redentor, the standard Brazilian Portuguese local pronunciation is the Art Deco style statue of Jesus Christ in Rio de Janeiro, Brazil, created by the French sculptor Paul Landowski, and the Brazilian engineer Hauto da Silva Cos The tower was built in cooperation with French engineer Albert) Caquot. Romanian sculptor Gheorghe Leonida shaped the face. The statue was built between 1922 and 1931 and is 30 meters (98 feet) high, excluding its 8 meters (26 feet) base. The arms extend 28 meters (92 feet) wide.

La estatua tiene una altura de 38 metros sobre un pedestal de 8 metros. Este monumento fue inaugurado el 12 de octubre de 1931, después de aproximadamente cinco años de construcción. Es la tercera estatua de Jesús de Nazaret más grande del mundo, detrás de la estatua de Cristo Rey de Świebodzin (Polonia), de 36 m, y el Cristo de la Concordia de Cochabamba (Bolivia), de 34.2 m. Es reconocida, por una empresa privada, como una de las nuevas siete maravillas del mundo moderno junto a Machu Picchu, la Gran Muralla China, el Coliseo de Roma, el Taj Mahal, Chichén Itzá y Petra.



Structure

The statue weighs 635 metric tons (625 long, 700 short tons), and is located at the peak of the 700-metre (2,300 ft) Corcovado mountain in the Tijuca Forest National Park overlooking the city of Rio de Janeiro. A symbol of Christianity across the world.

La construcción de hormigón armado, de más de 1000 toneladas, combina ingeniería, arquitectura y escultura; y tiene entre sus logros el hecho de que nadie muriera en accidente durante las obras, algo que no era normal en la época y menos con proyectos de esa dimensión. Por las difíciles condiciones de construcción, que incluían trabajar sobre una base en la que casi no cabía el andamio, soportar fuertes vientos y desarrollar la gran estructura de la estatua, cuyos brazos se extienden hacia el vacío y la cabeza queda inclinada en un desafío a la ingeniería, Levy calificó la obra de «hercúlea».



Design and construction

Local engineer Heitor da Silva Costa and artist Carlos Oswald designed the statue. French sculptor Paul Landowski created the work. In 1922, Landowski commissioned fellow Parisian Romanian sculptor Gheorghe Leonida, who studied sculpture at the Fine Arts Conservatory in Bucharest and in Italy. A group of engineers and technicians studied Landowski's submissions and felt building the structure of reinforced concrete (designed by Albert Caquot) instead of steel was more suitable for the cross-shaped statue. The concrete making up the base was supplied from Limhamn, Sweden. The outer layers are soapstone, chosen for its enduring qualities and ease of use. Construction took nine years, from 1922 to 1931 and cost the equivalent of US\$250,000 (equivalent to \$3,600,000 in 2020).

El rostro de la estatua fue creado por el escultor rumano Gheorghe Leonida. Leonida estudió escultura en el Conservatorio de Bellas Artes de Bucarest y tras completar su formación con tres años de estudios en Italia, ganó un premio por la escultura Réveil (en francés, 'Despertar'). Después de eso, se trasladó a París, donde, por su obra Le Diable (en francés, 'El Diablo'), fue de nuevo galardonado con un premio. Tras adquirir fama en Francia como retratista, fue incluido por Paul Landowski en su equipo.

Force Balance

受力平衡

Physical operations

物理运算

$$F = G \frac{m_1 m_2}{d^2}$$

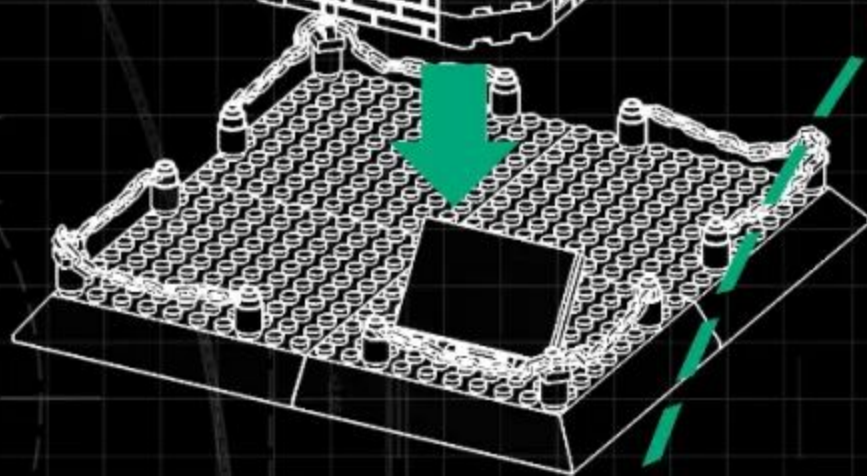
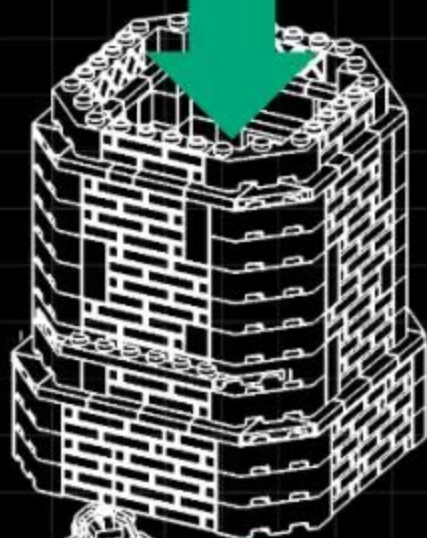
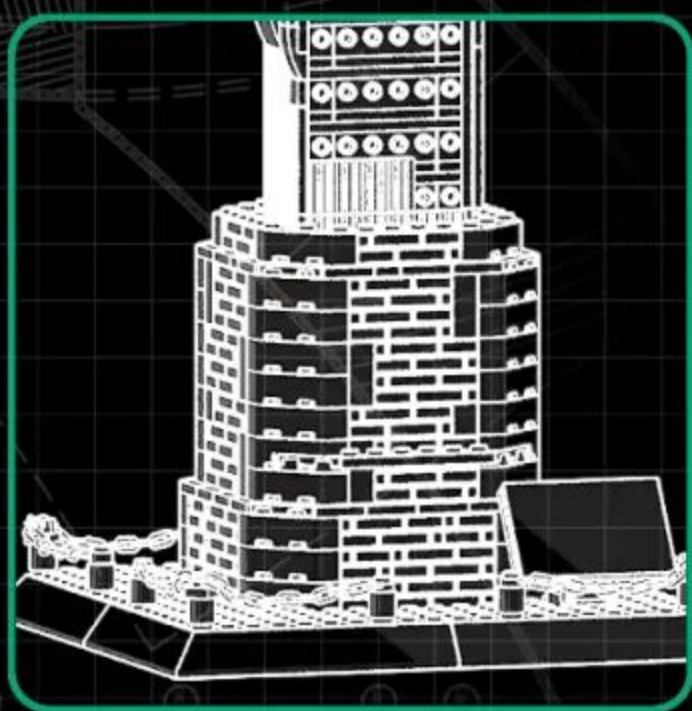
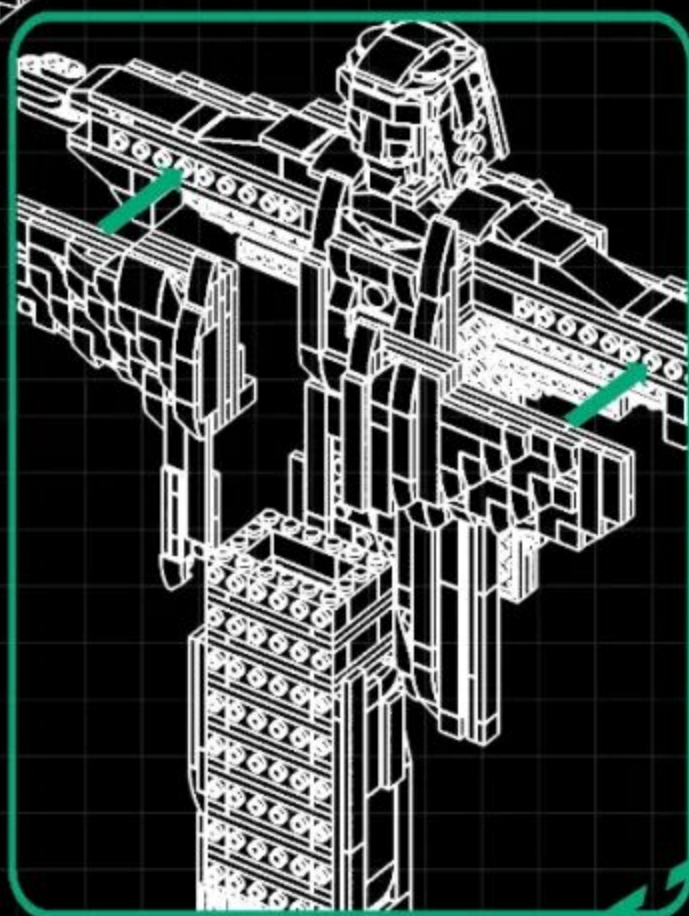
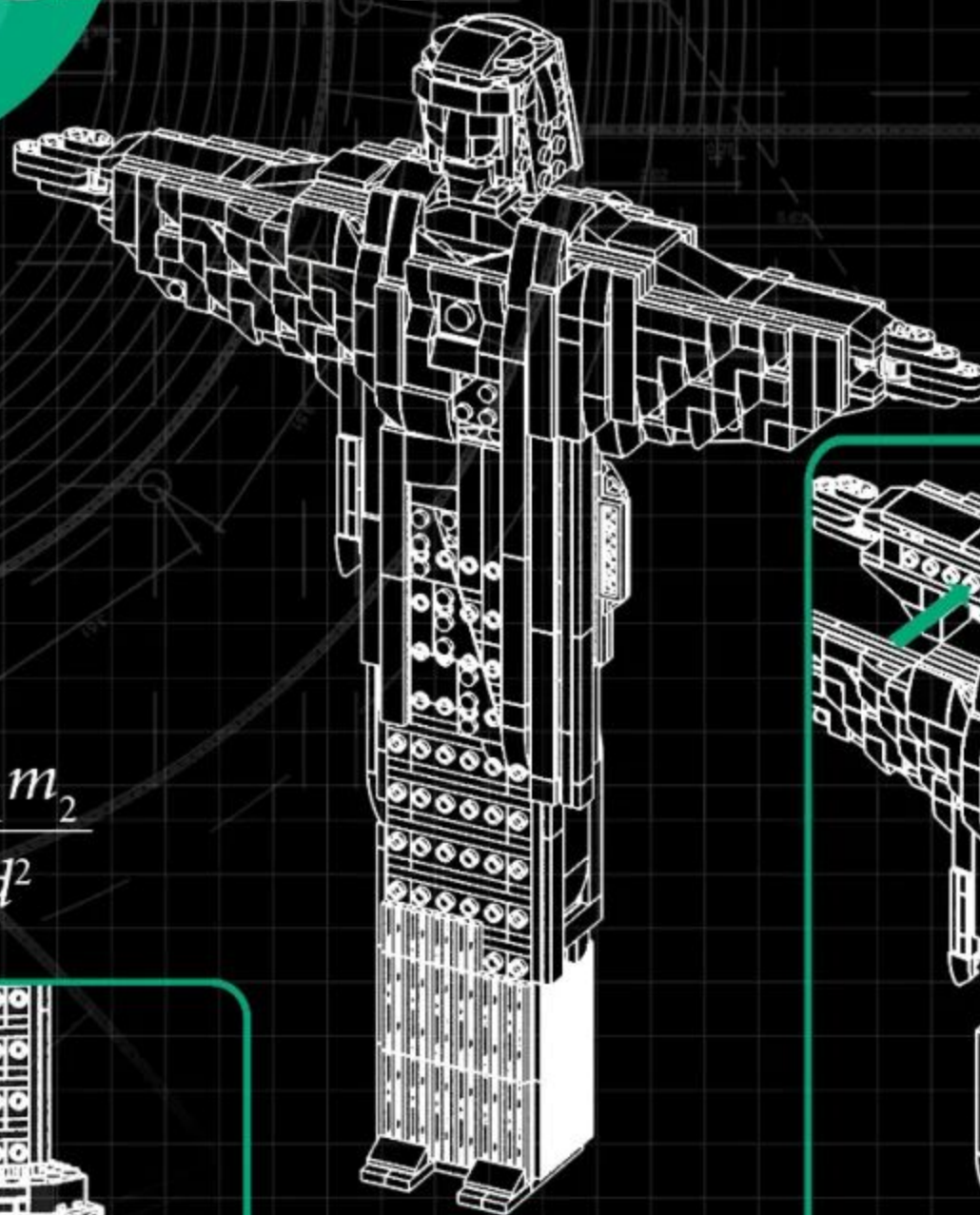

Creation and thinking

创作·思考

Special parts

特殊零件的开发利用

$$S=4\pi \cdot r^2$$

$$a^2+b^2=c^2$$



WG1250
无孔2分圆



WG1321
2倍双平线



WG1349
弧形车头盖



WG1316
2高4孔墙砖

$$\sin^2 a + \cos^2 a = 1$$



features and function

特点.功能

Main Color Matching

配色方案

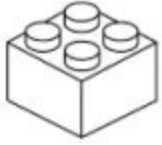

White



Pantone black6C



Pantone 7509C



Pantone Cool Gray 9C



Pantone Cool Gray 6C



Color matching

Adopting 2 main colors, White and black as the main color, the more reasonable and Cool Gray color matching on the original building, making the product more atmospheric and the whole design is more reasonable.

Christ the Redeemer

救世基督像

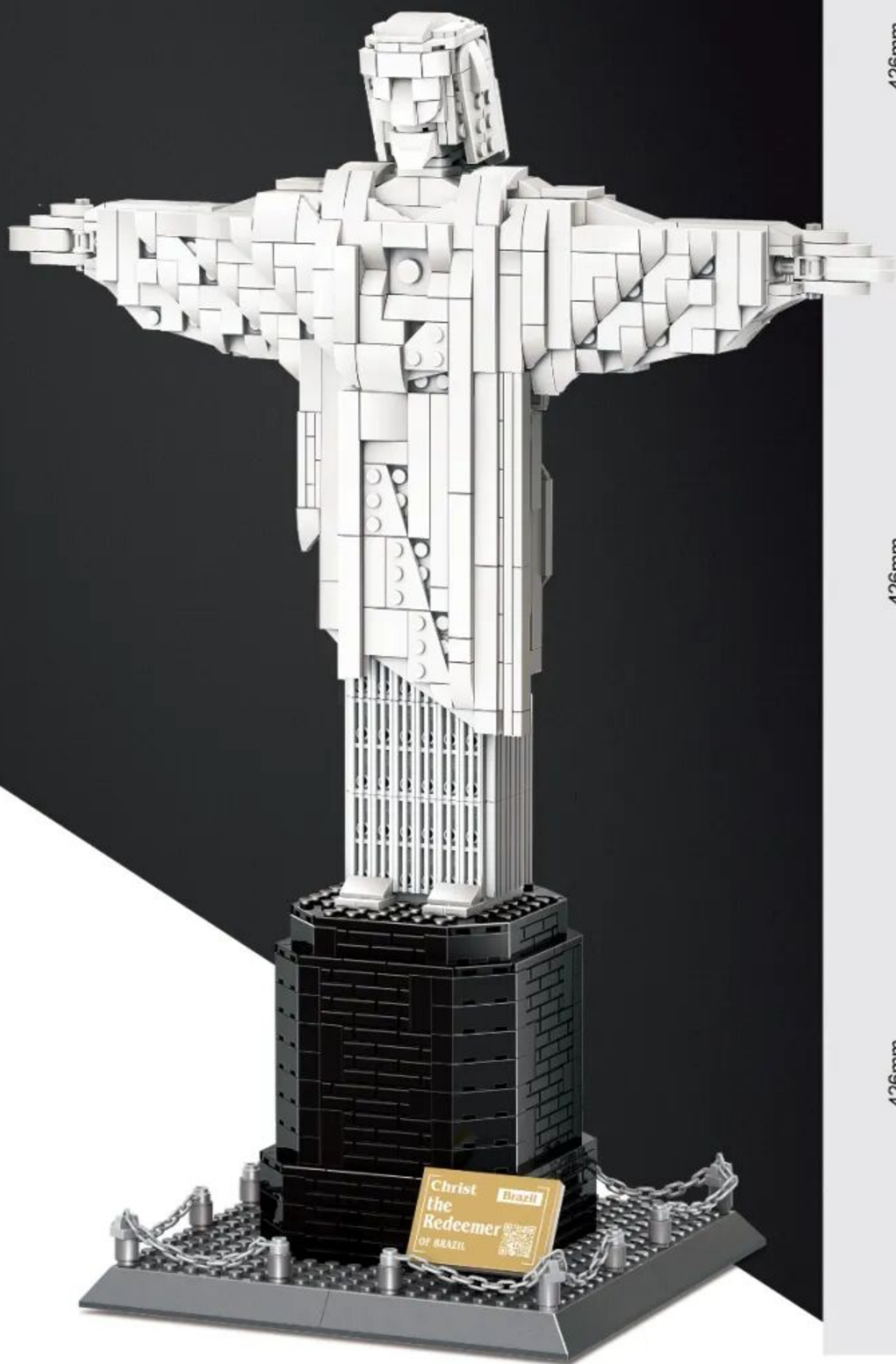

Back

426mm



319mm

Left

426mm



175mm

Front

426mm



319mm

Product Size:426X319x175mm

Creative Ability



Family Interaction



Observation Ability



Thinking Ability



Practical Ability





■ First open the product packaging according to the instructions.

按指导用正确方式拆解产品外包装。



■ Summarize all parts to count the number of familiar accessories.

对照说明书清单确认积木包数量与积木数量。



■ Arranging all accessories by color helps to quickly install the product.

把确认好的积木以类型、颜色进行分类排好以便安装。



■ Carefully install the product and learn about building.

按说明书步骤拼装并完成你的积木模型。



Instructions For Use

积木起件器使用说明
Brickseparator

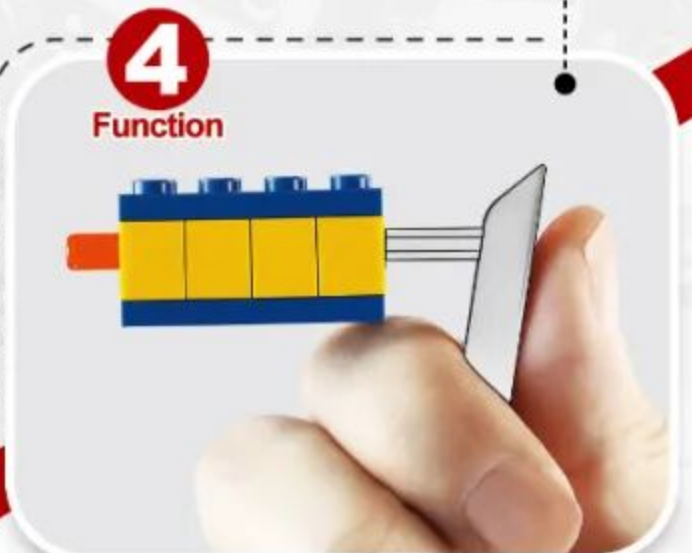
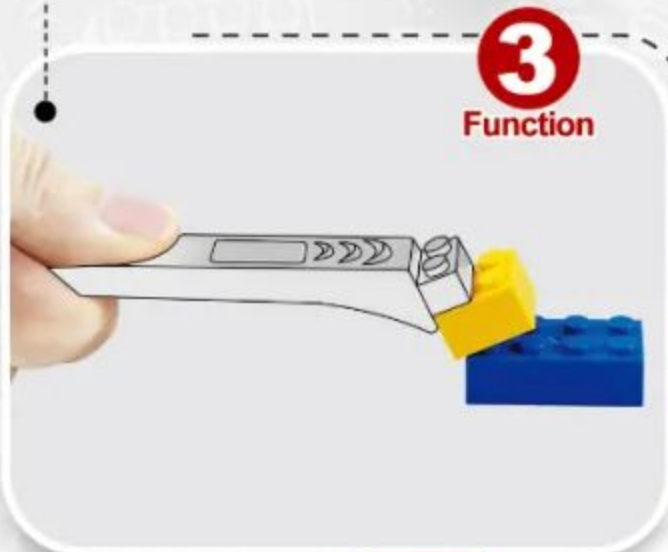
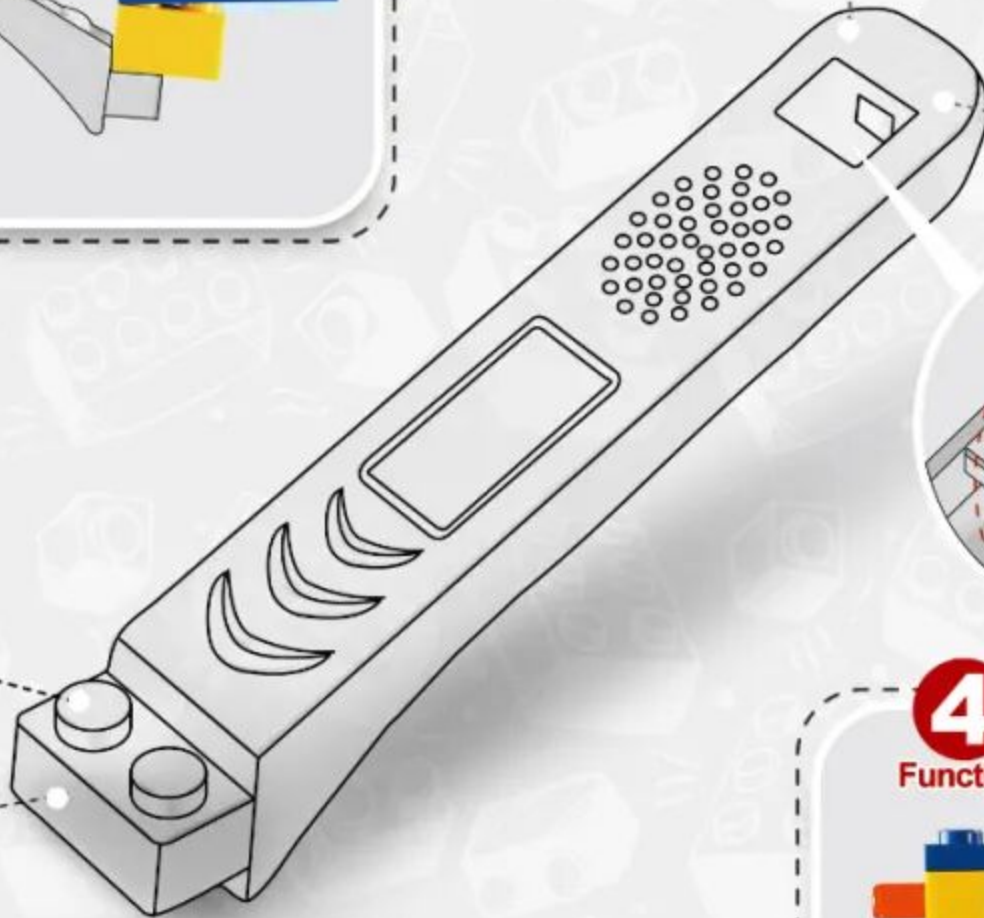
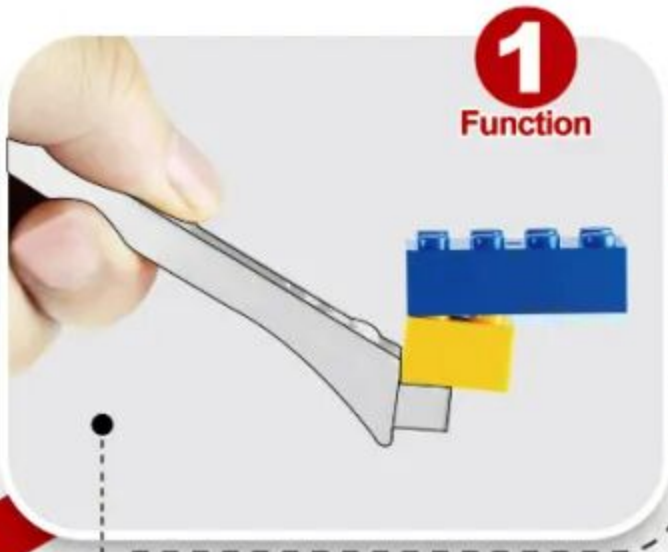

4 ways to make installation easier
让安装更简单

1:1 Physical Reference Table

十字棒配件1:1尺寸参照表



Instructions For Use
让安装更简单



2 $(1 \times 2) = 2$

3 $(1 \times 3) = 3$

4 $(1 \times 4) = 4$

5 $(1 \times 5) = 5$

6 $(1 \times 6) = 6$

7 $(1 \times 7) = 7$

8 $(1 \times 8) = 8$

9 $(1 \times 9) = 9$











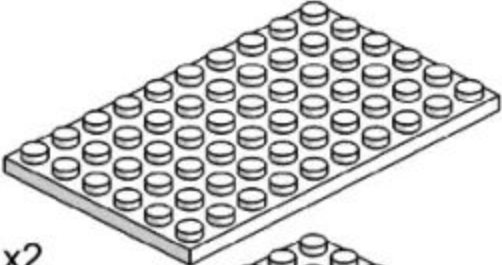
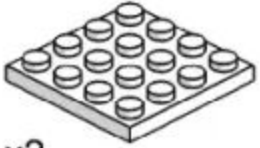
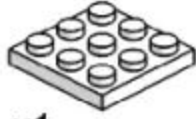

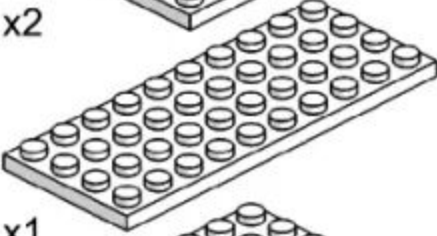

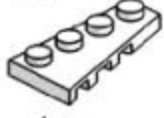

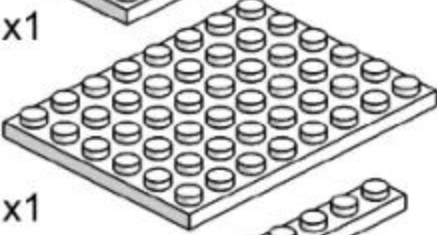
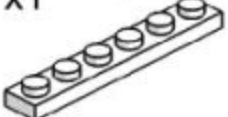
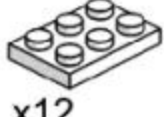
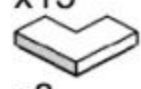

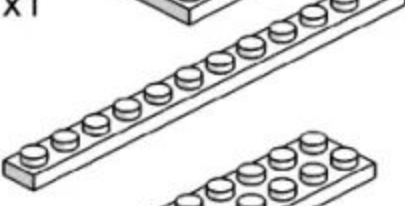
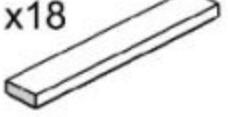



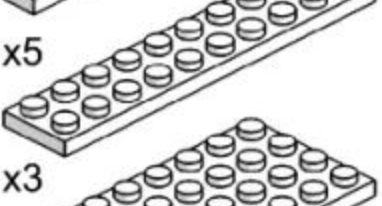
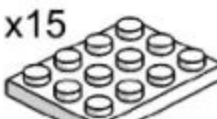



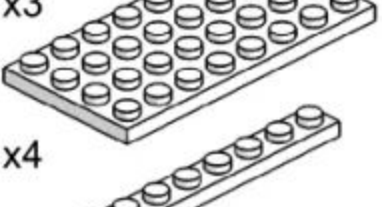

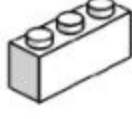



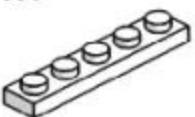

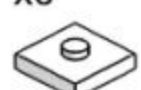

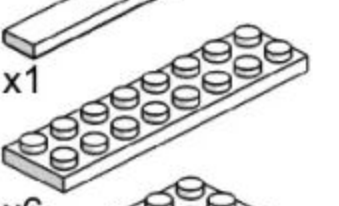



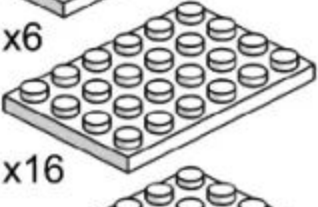
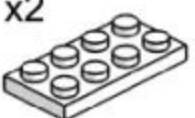
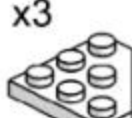

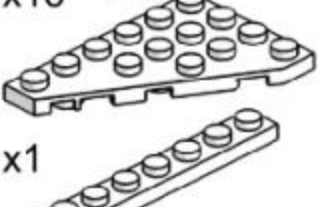
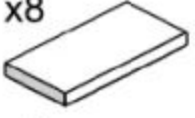
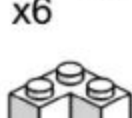

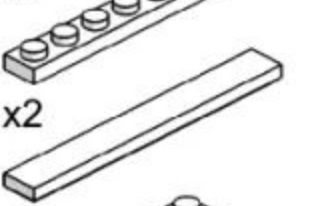
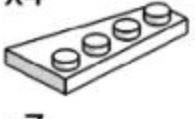
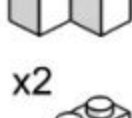



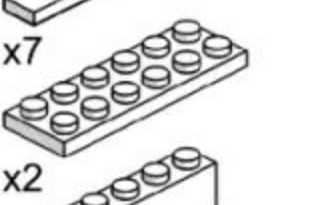

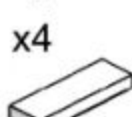

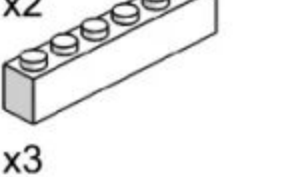
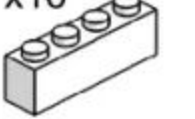
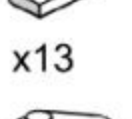



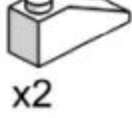

10 $(1 \times 10) = 10$

12 $(1 \times 12) = 12$

16 $(1 \times 16) = 16$

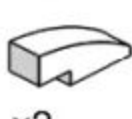
PARTS LIST

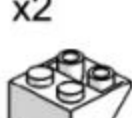
配件清单

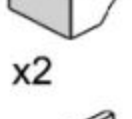
				
x2	x2	x1	x2	x24
				
x1	x1	x1	x15	x1
				
x1	x18	x12	x8	x1
				
x1	x15	x1	x13	x2
				
x5	x6	x3	x6	x1
				
x3	x1	x2	x1	x9
				
x4	x1	x4	x3	x4
				
x1	x2	x3	x4	x17
				
x1	x8	x6	x8	x2
				
x6	x4	x2	x1	x1
				
x16	x7	x4		
				
x1	x16	x2	x1	x31
				
x2	x2	x2		
				
x7	x2	x2		
				
x2	x12			
x3	x46			

产品有增补件请以实物为准

If product has additional parts, please in kind prevail.

PARTS LIST

配件清单

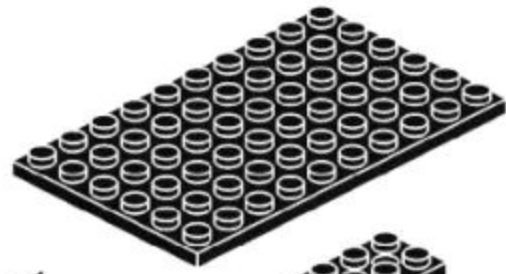

x1

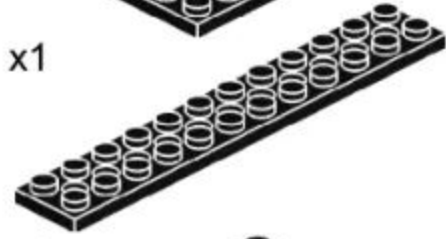

x4

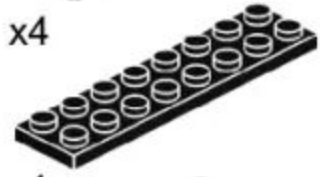

x1



x4



x2



x1



x2



x16



x2



x2



x21



x12



x44



x28



x2



x1



x1



x1



x1



x1



x6



x1



x28



x1



x12



x14



x12



x7



x1



x2



x6



x12



x12



x4



x20



x4



x4



x4



x12



x4



x4



x1



产品有增补件请以实物为准

If product has additional parts, please in kind prevail.



156PCS

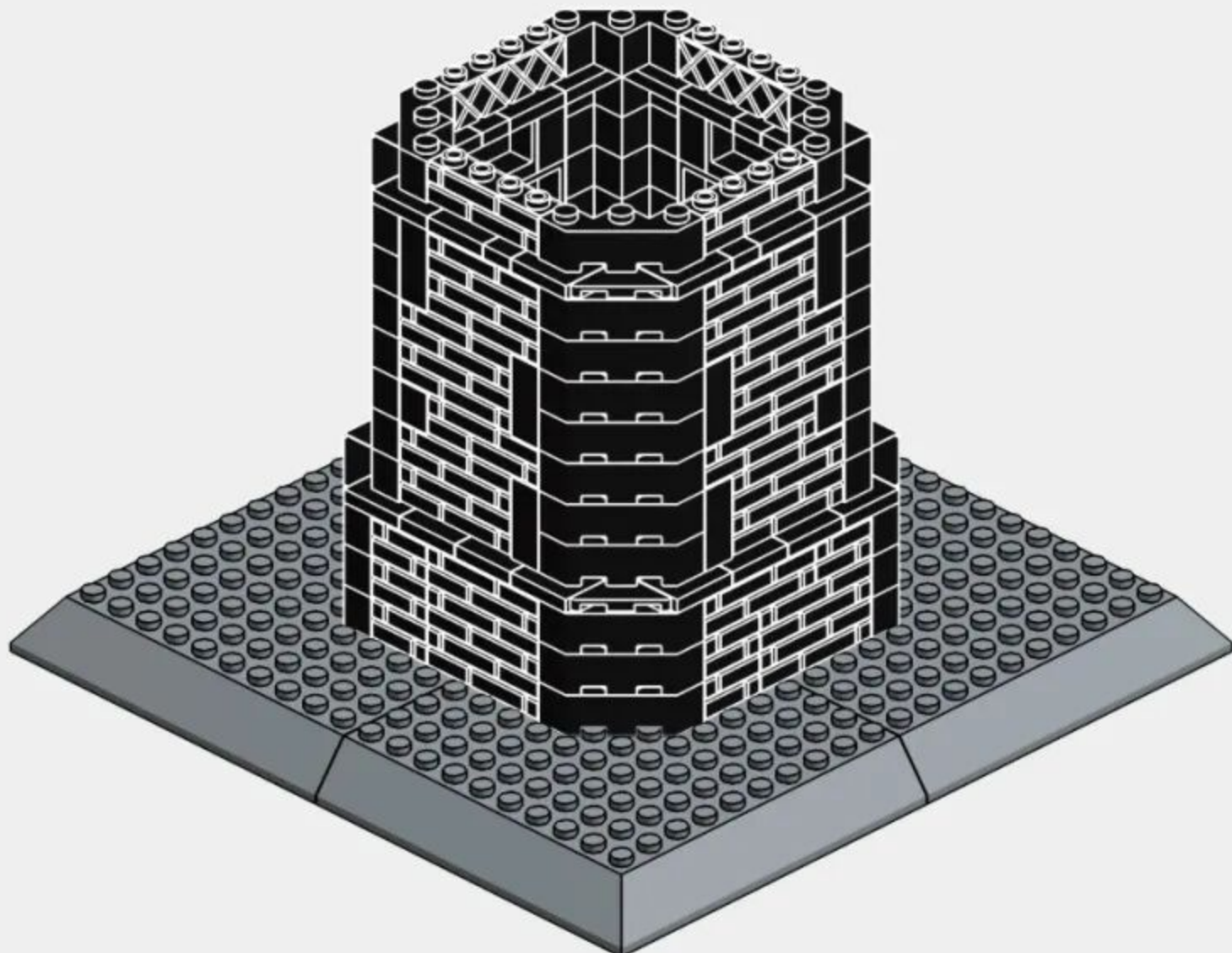

1-1

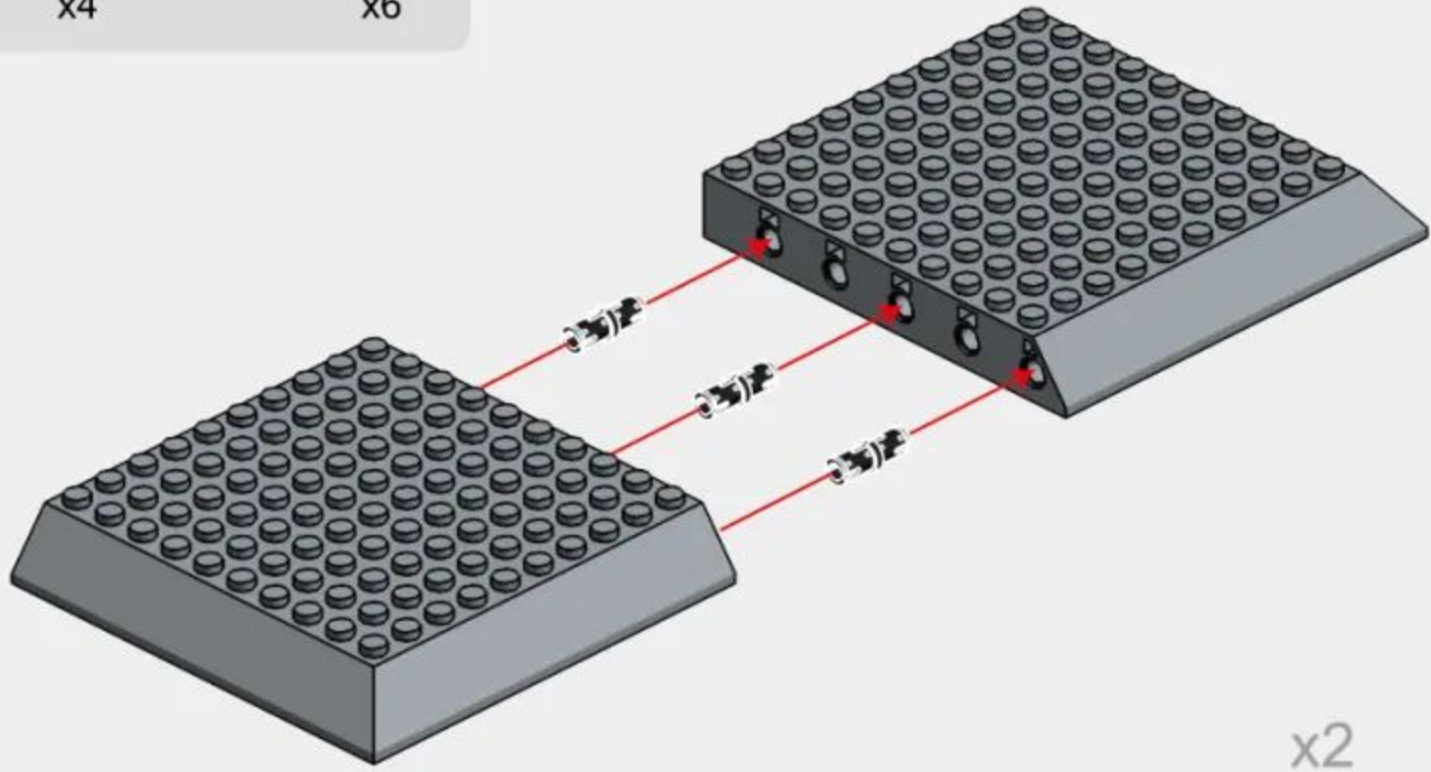

1-2

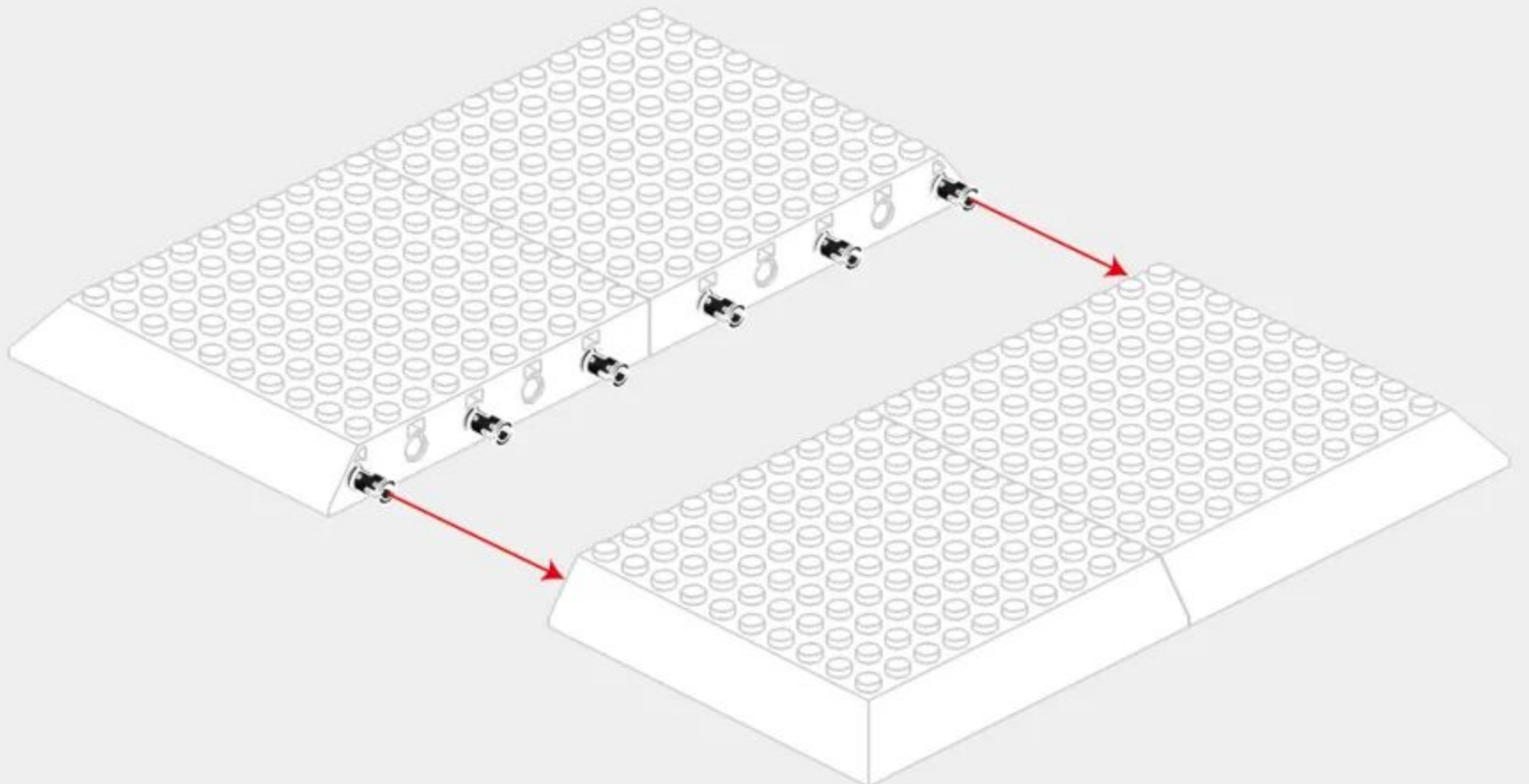

1-3

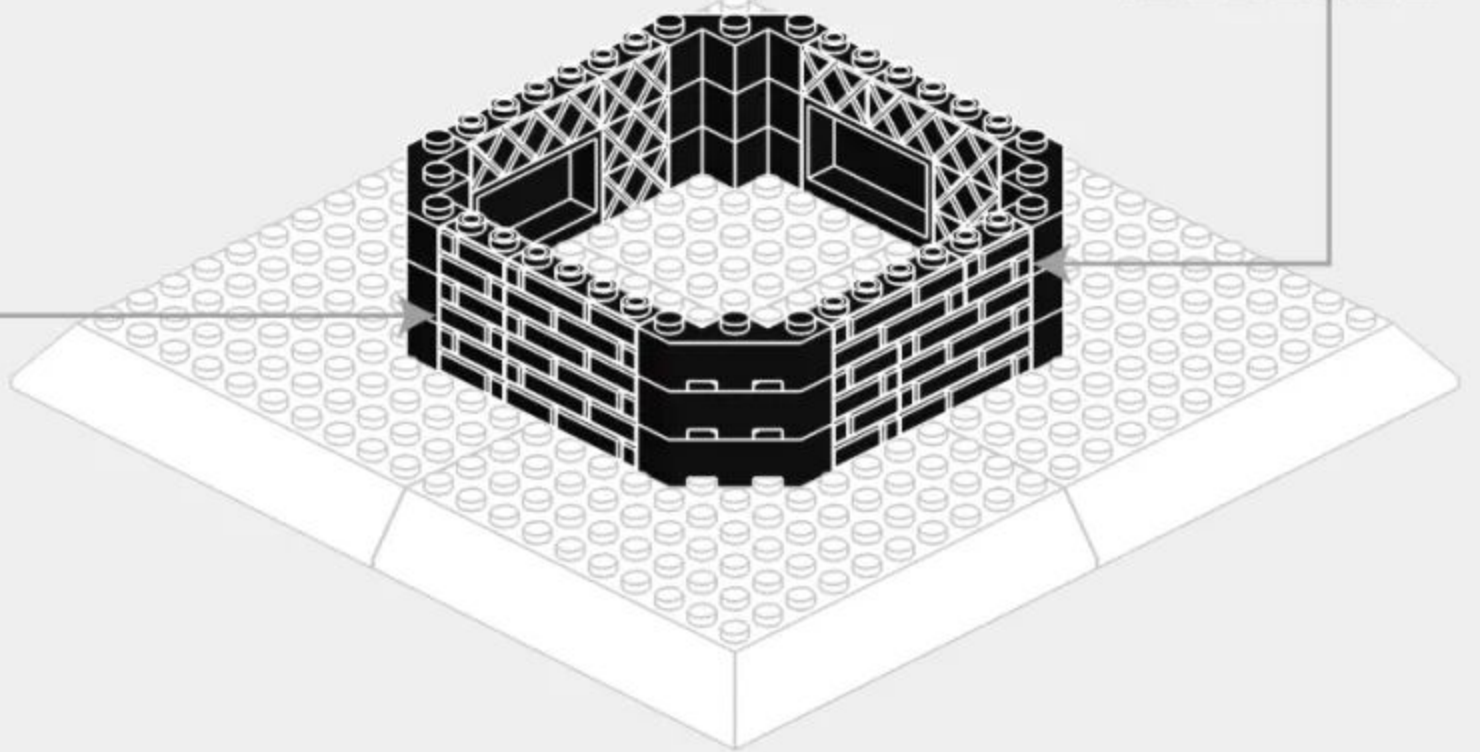
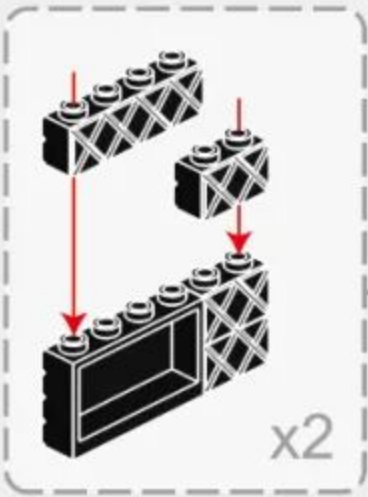
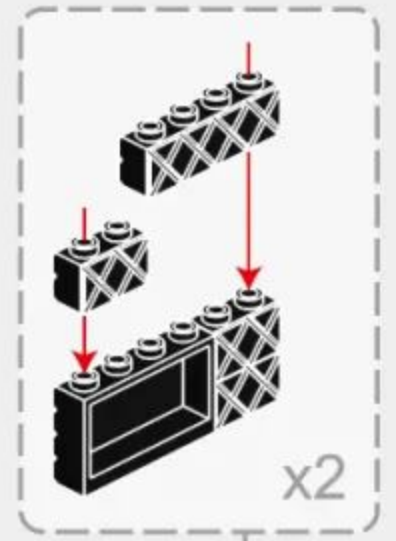
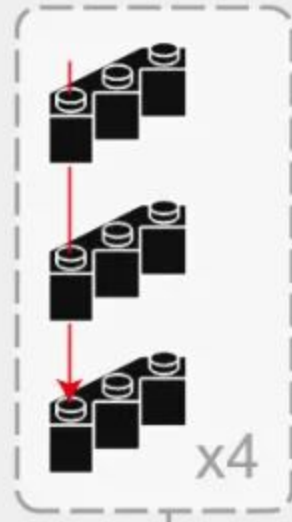
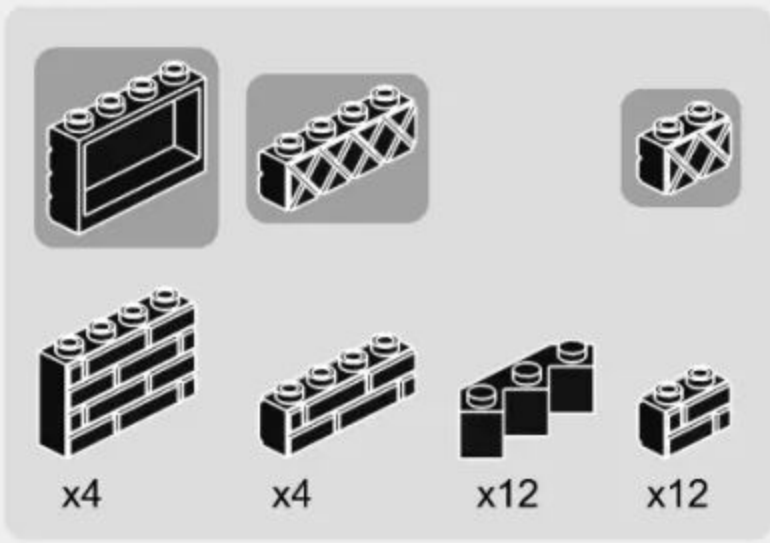

1-4

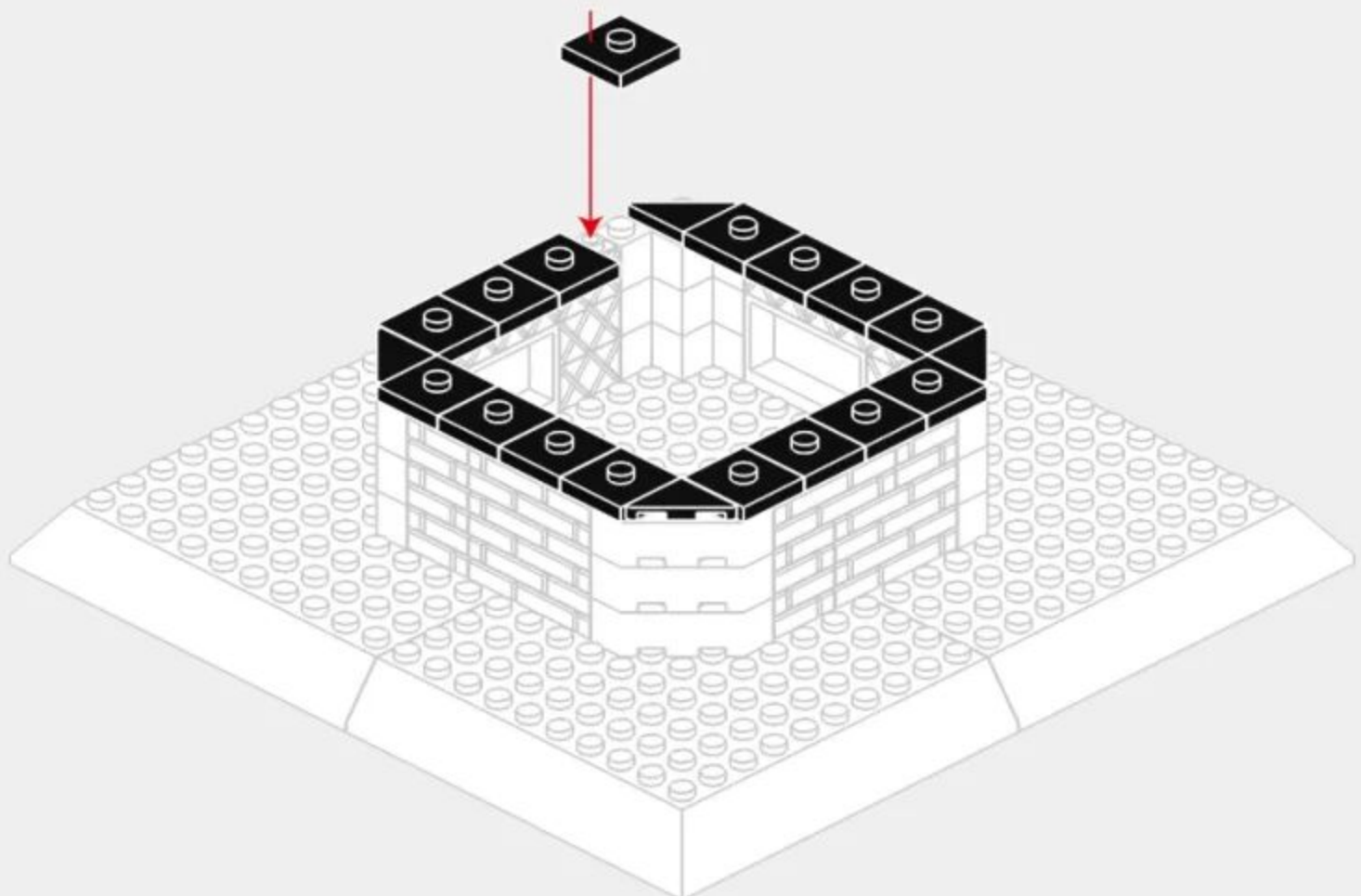

1-5

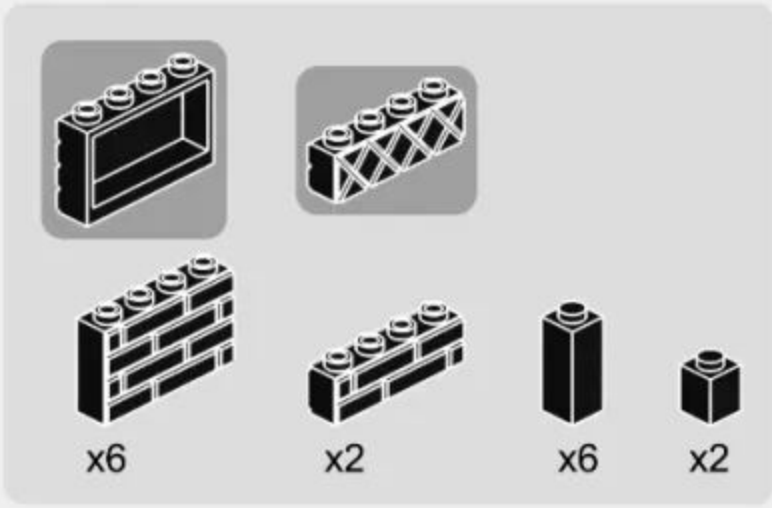

1-6

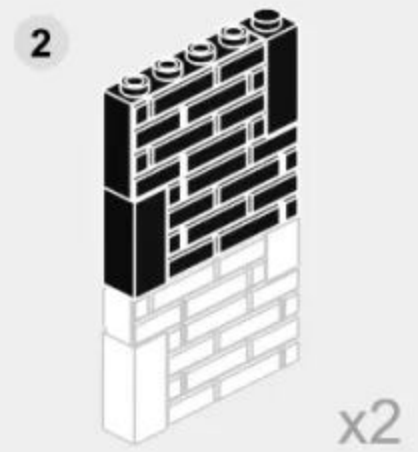
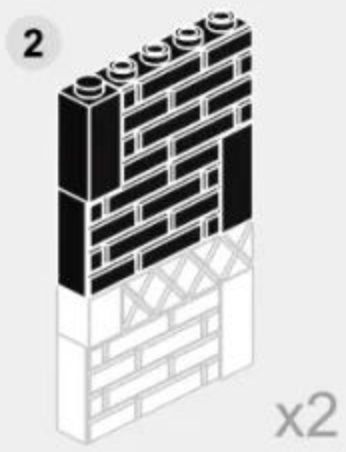
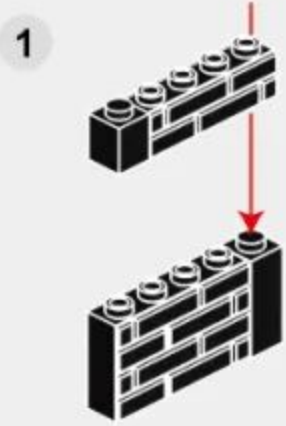
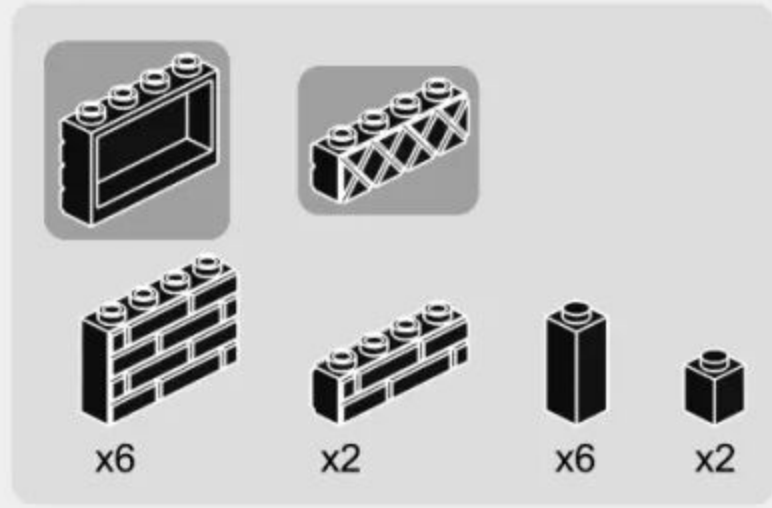

1-7

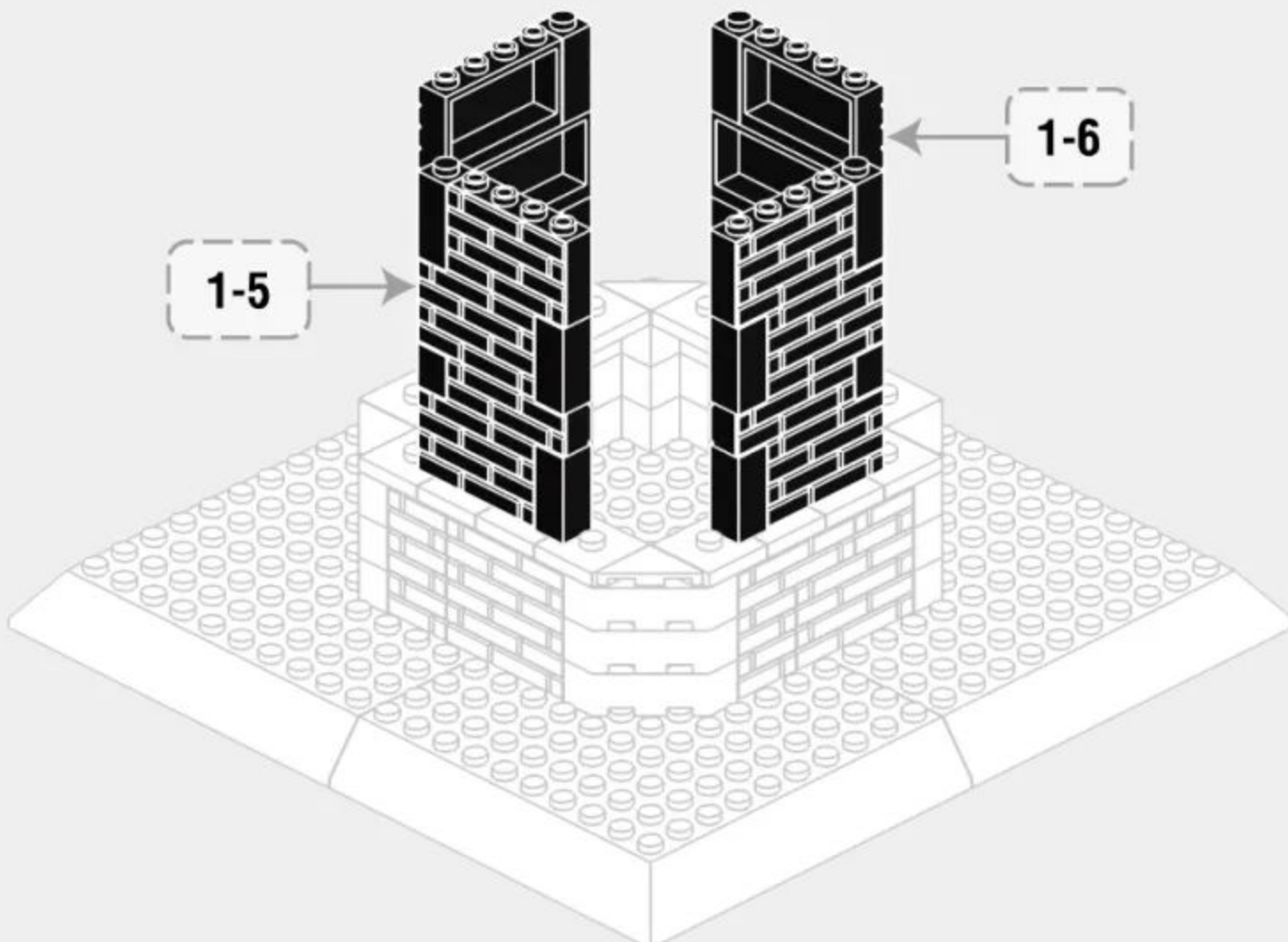

1-8

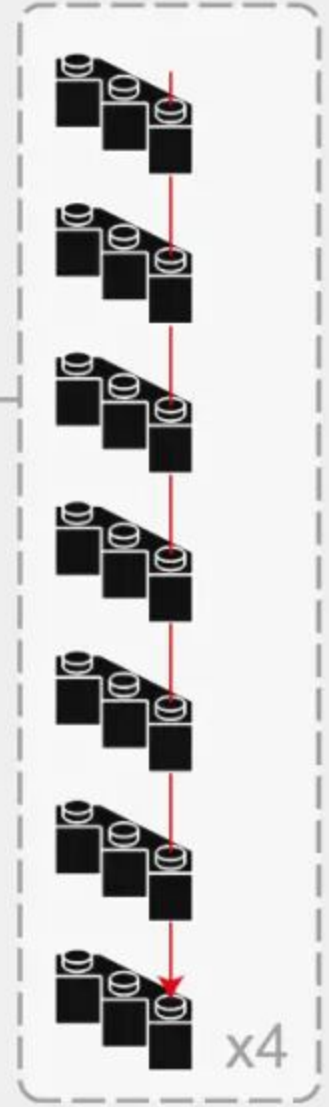
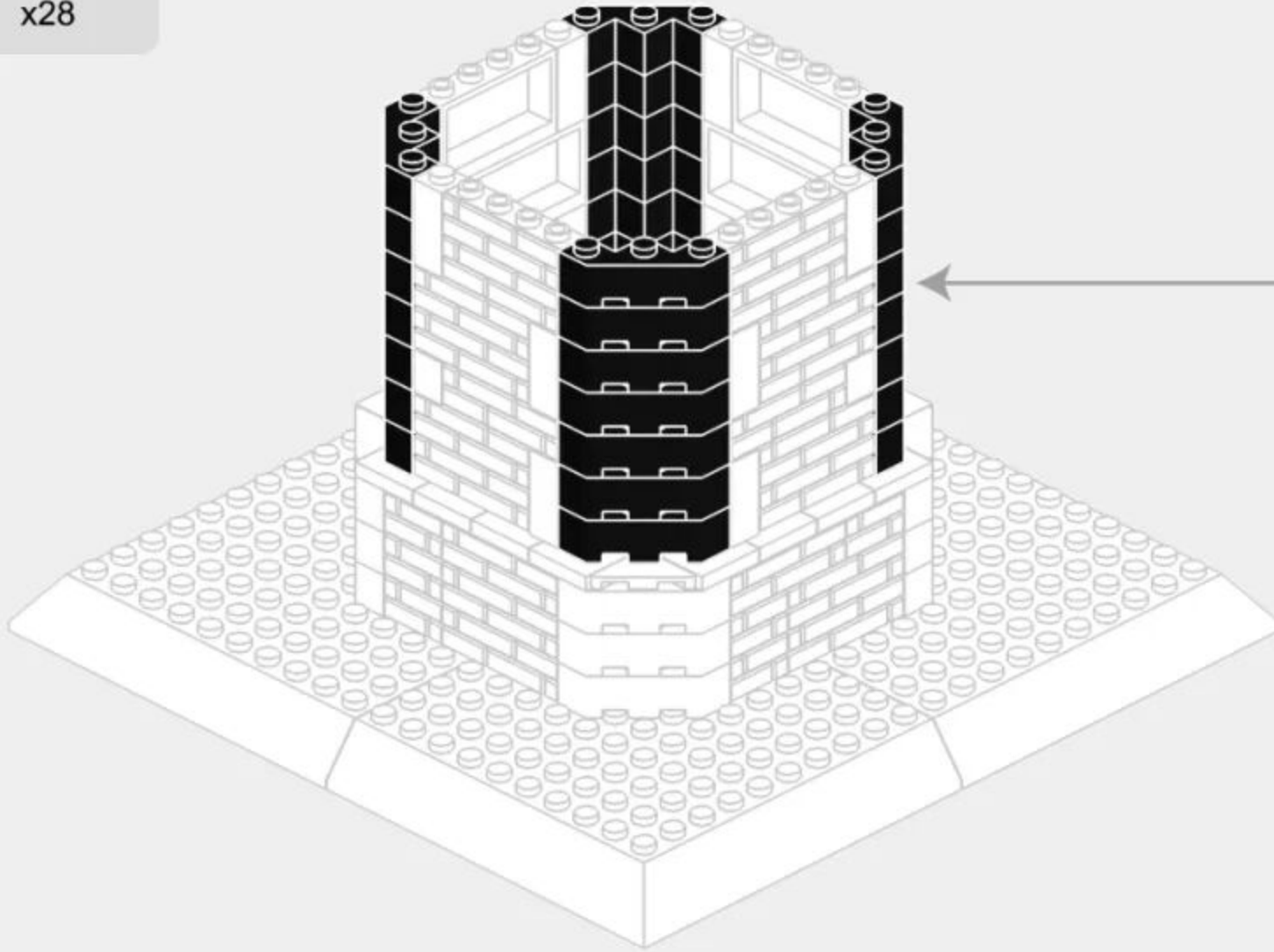

1-9

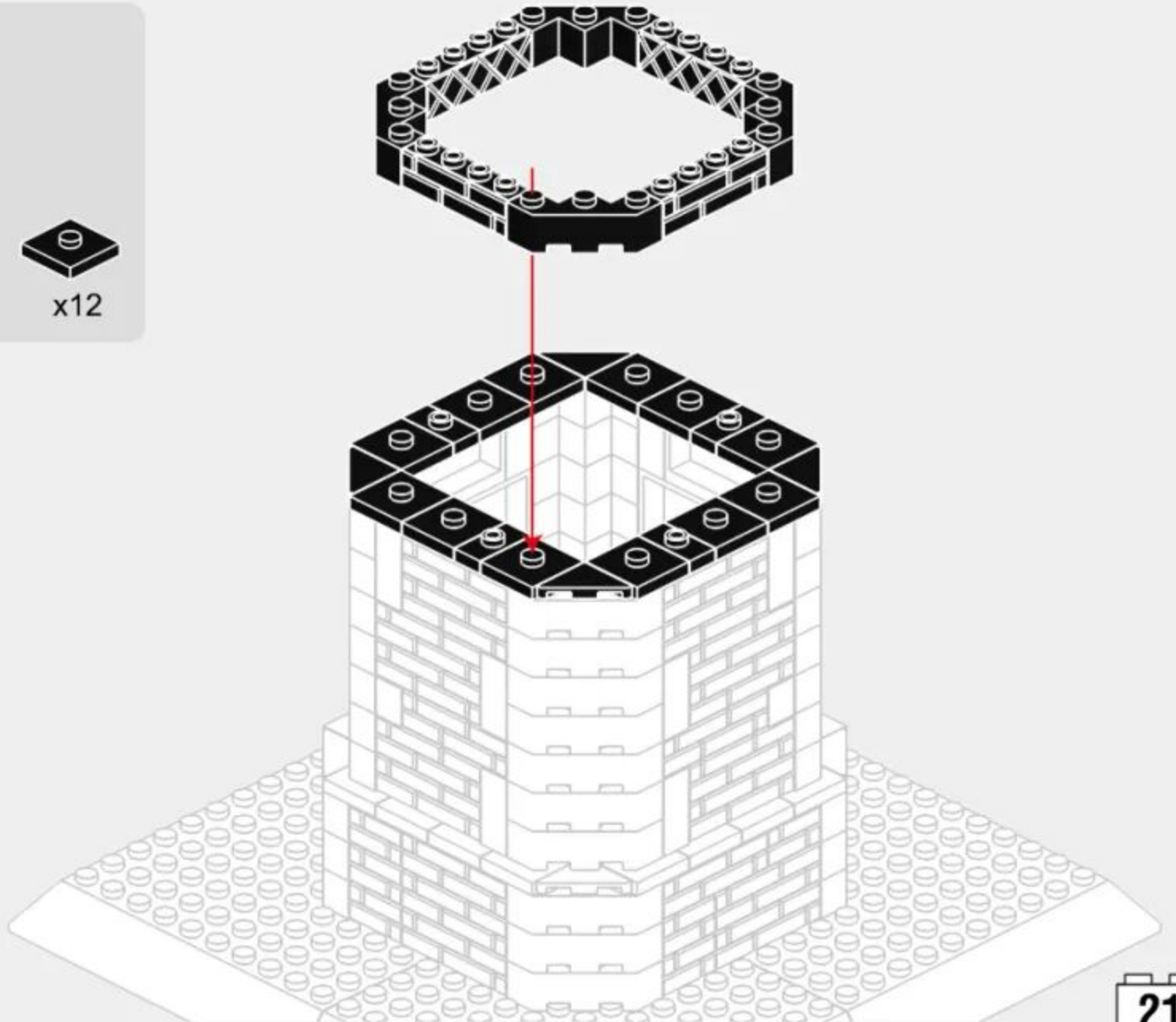
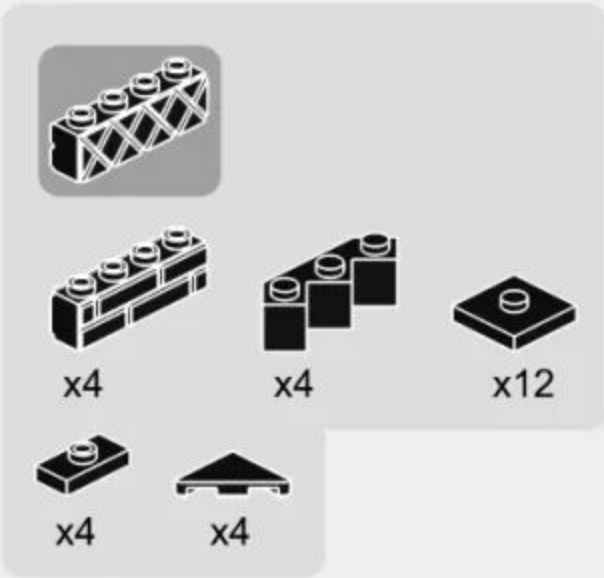



264PCS

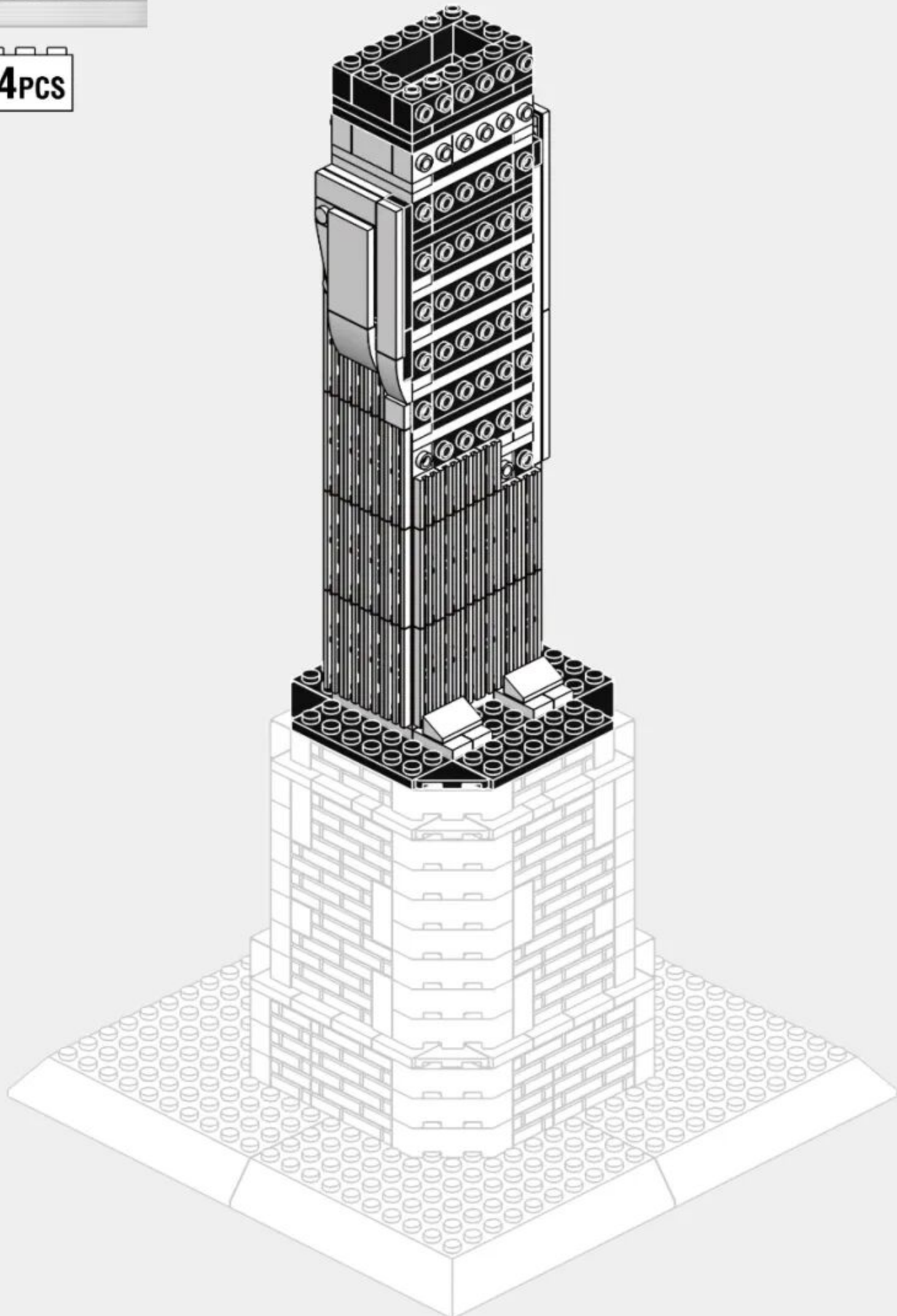

2-1

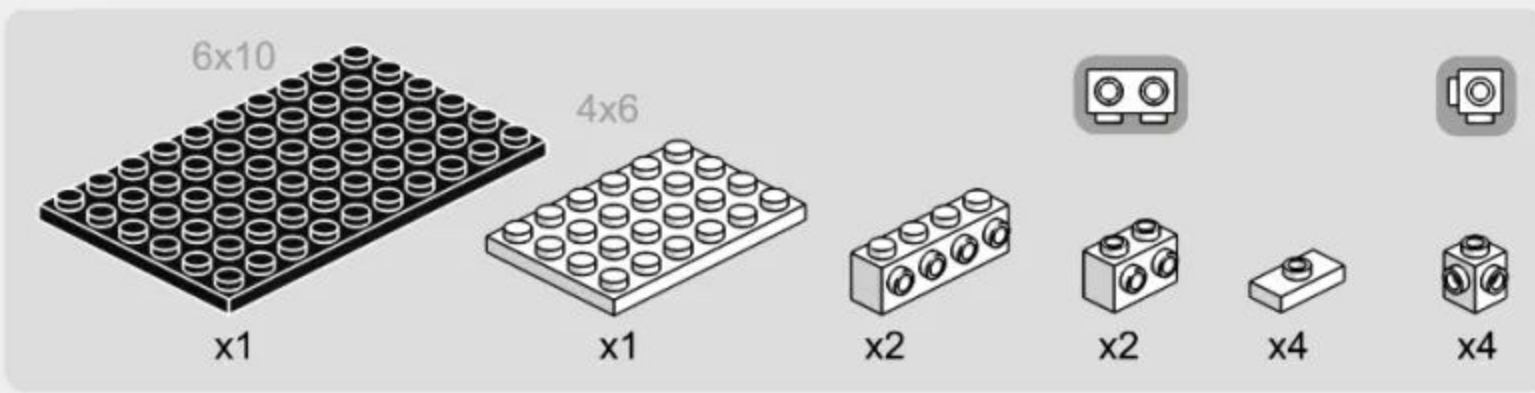

1

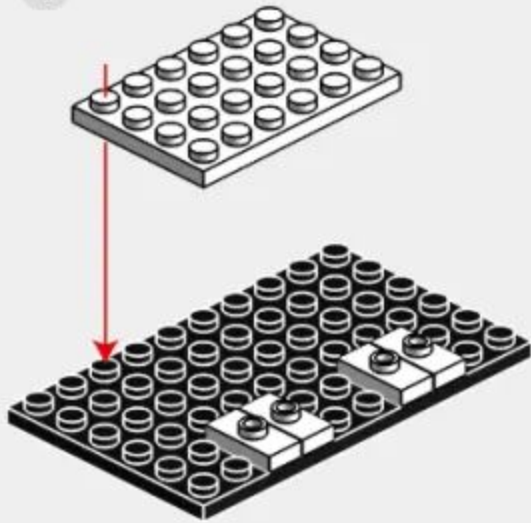

2

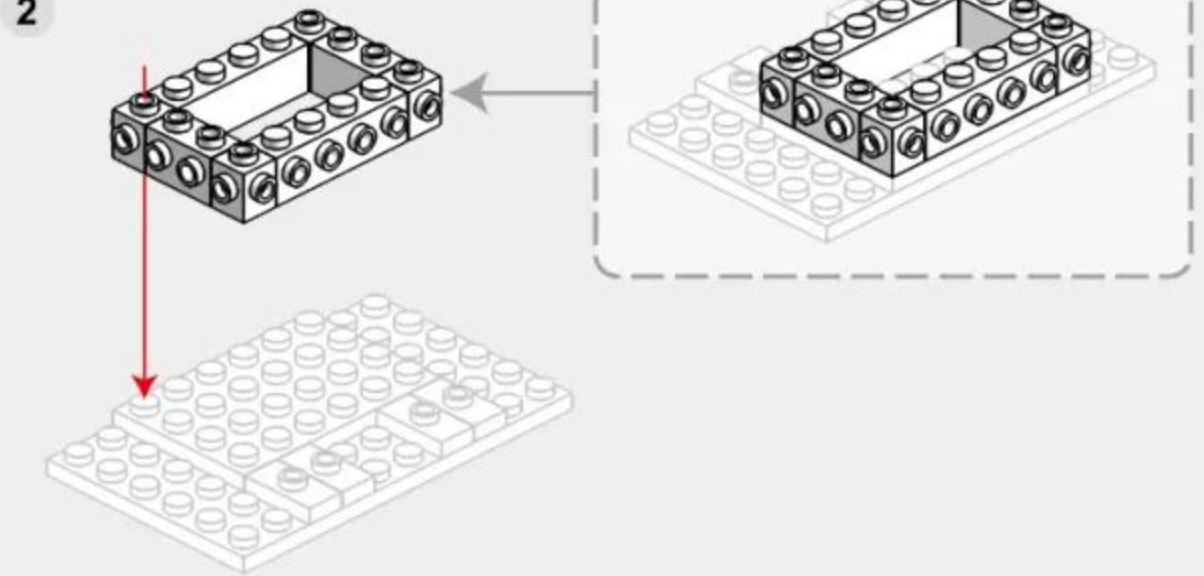

2-2

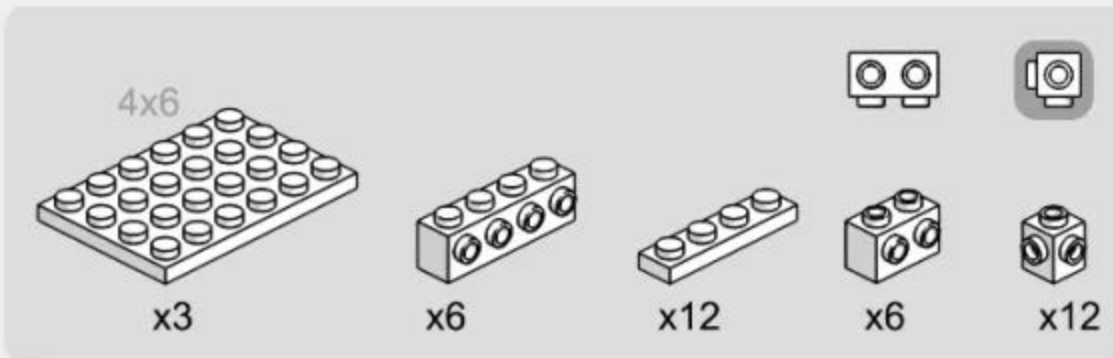

1

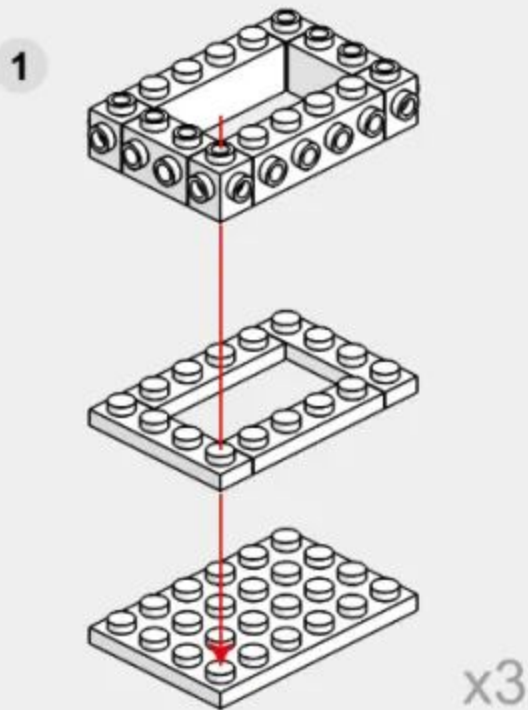

2

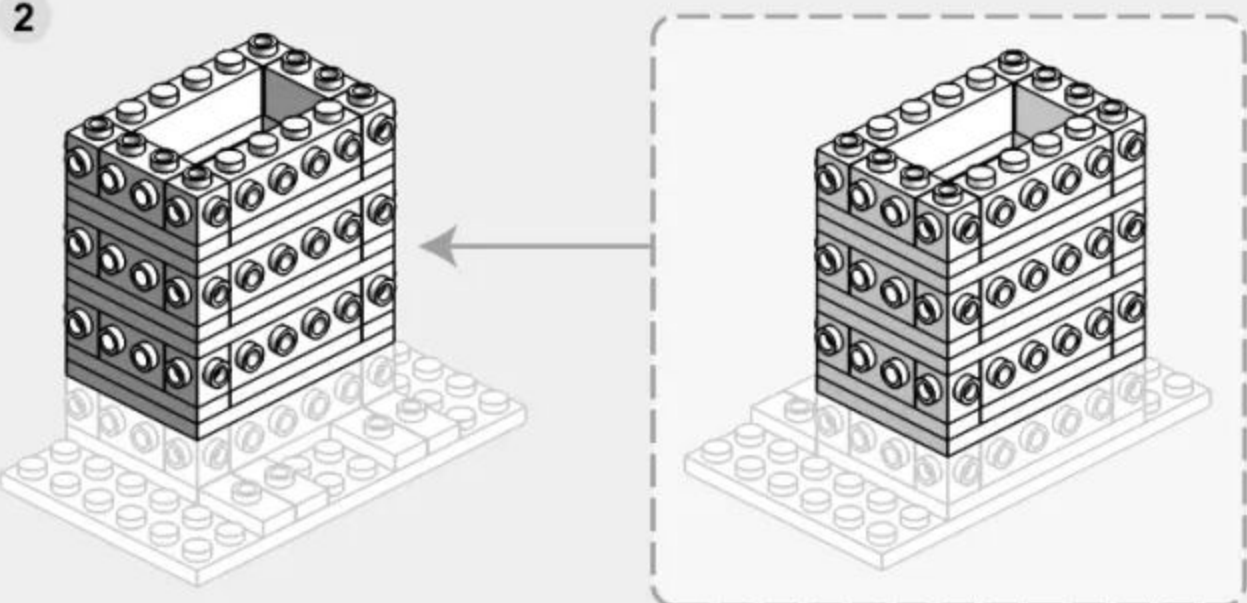

2-3

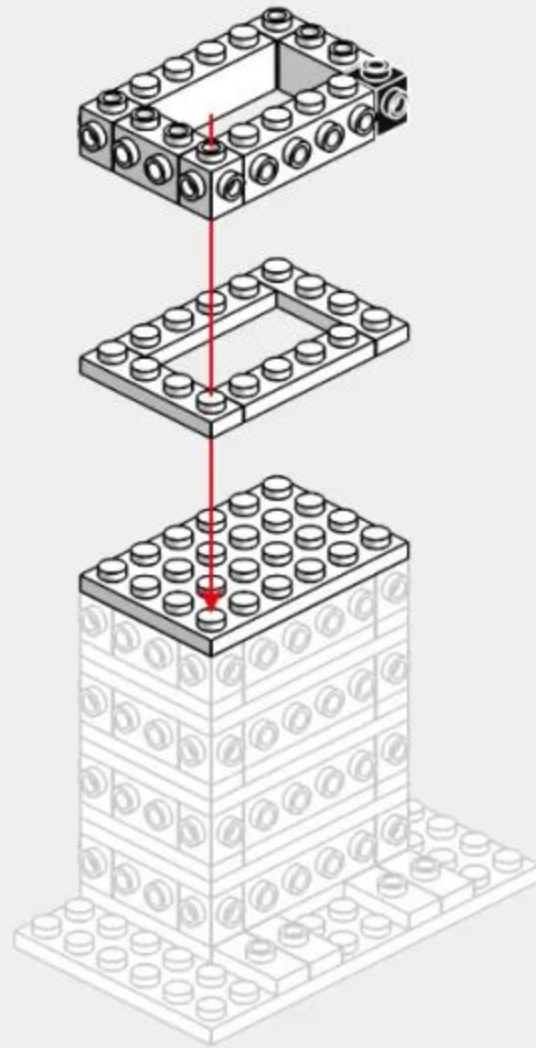
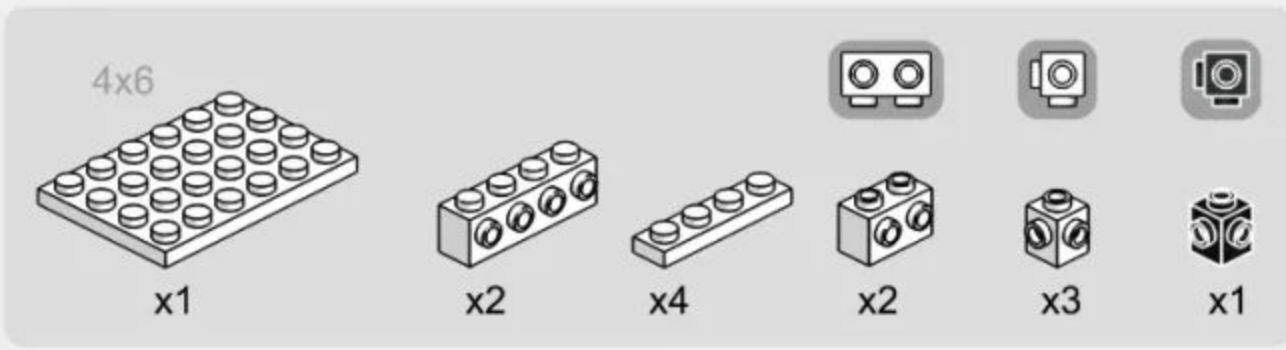

2-4

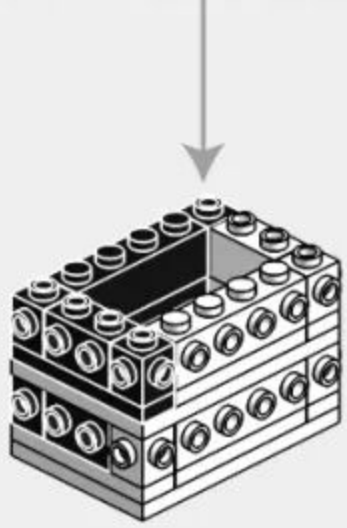
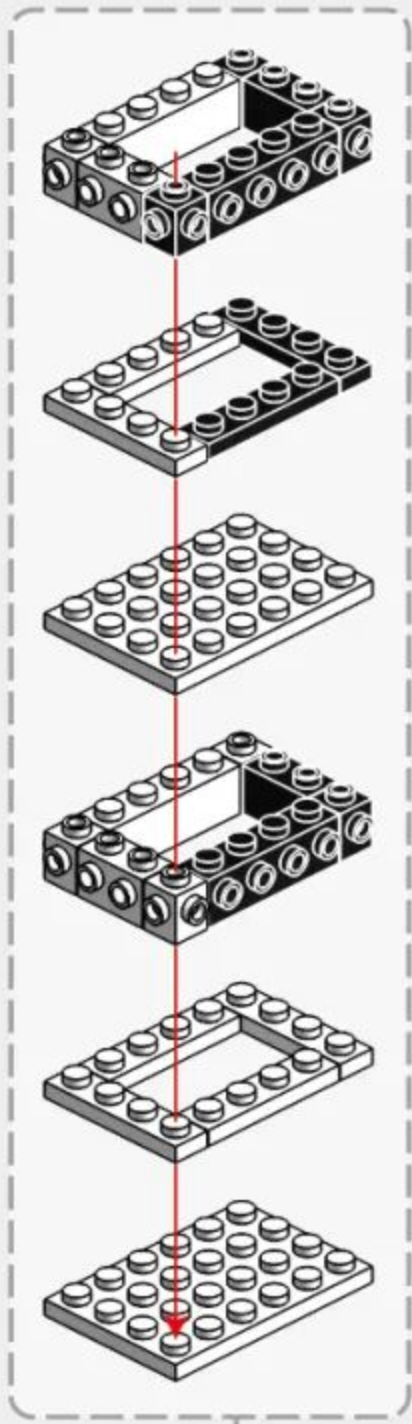
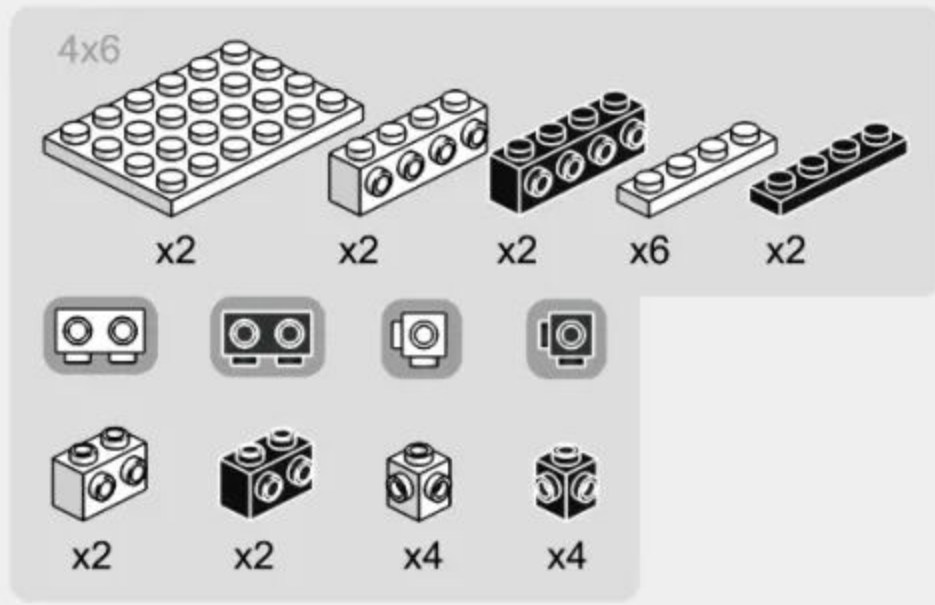

2-5

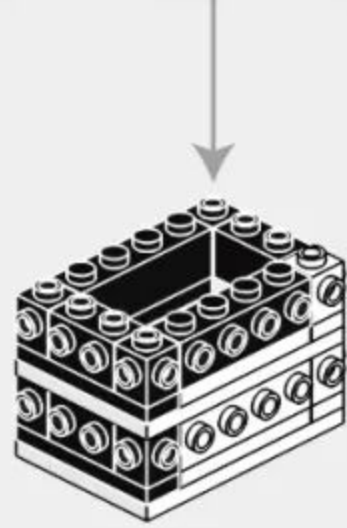
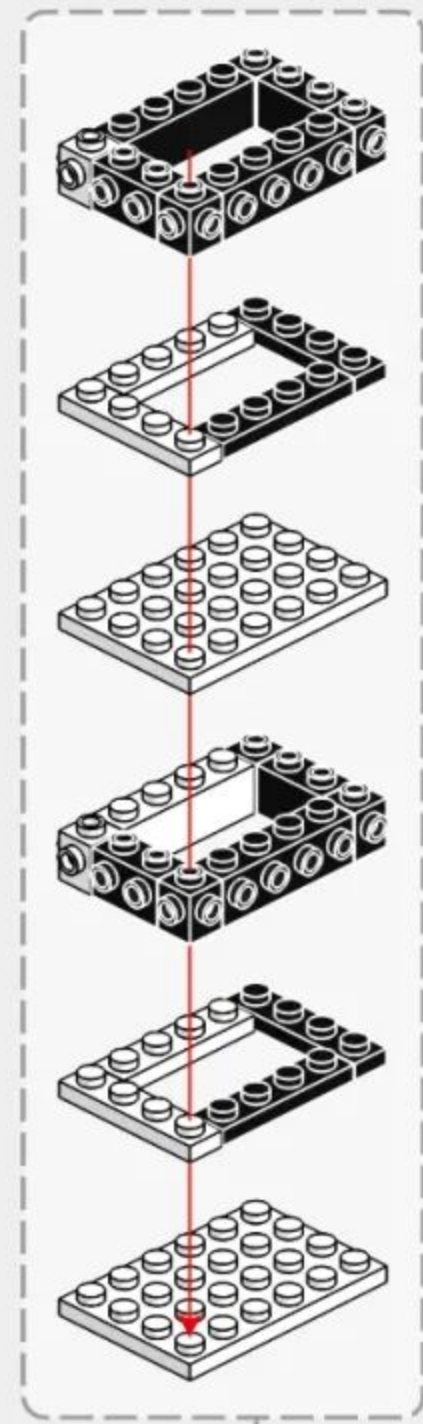
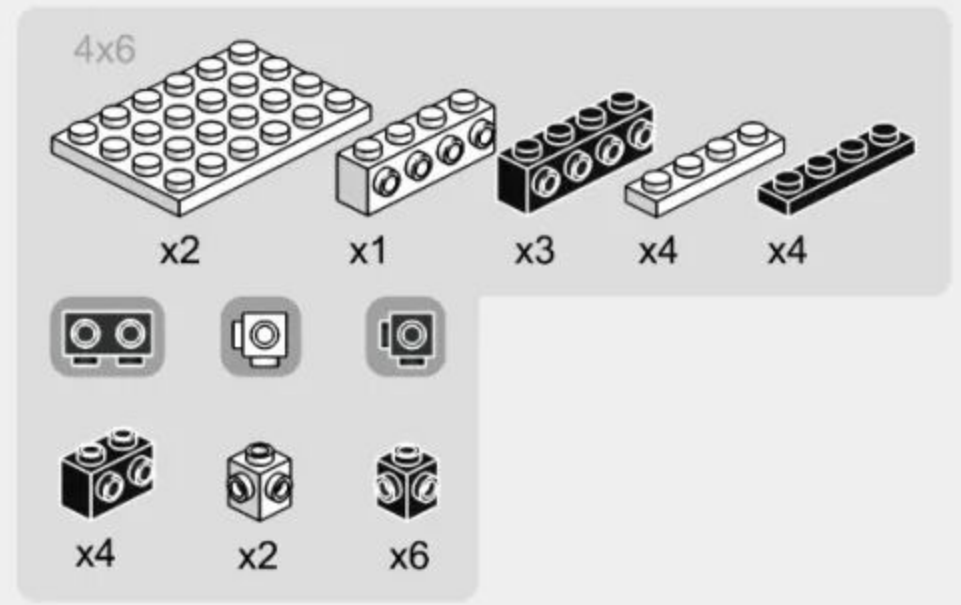

2-6

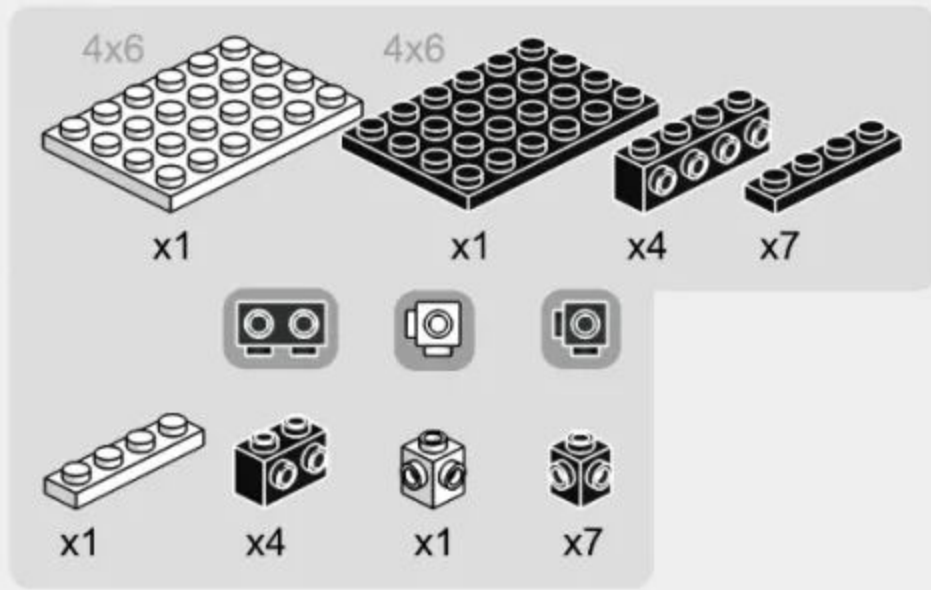

2-7

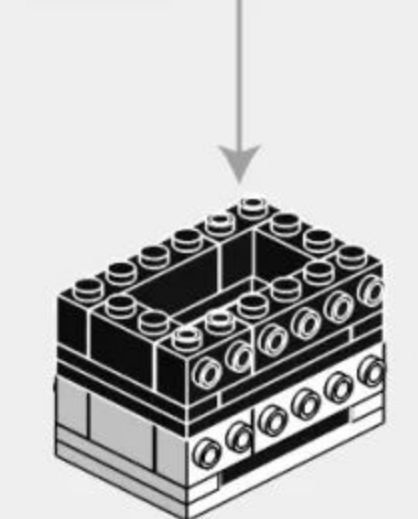
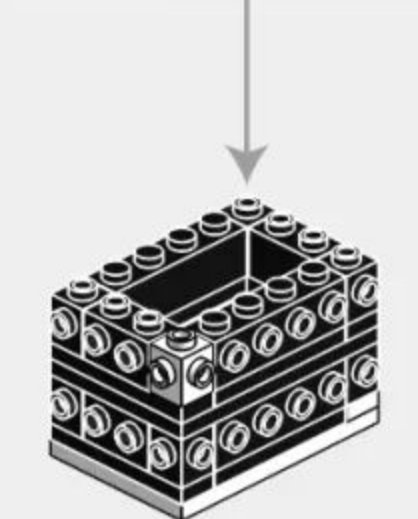
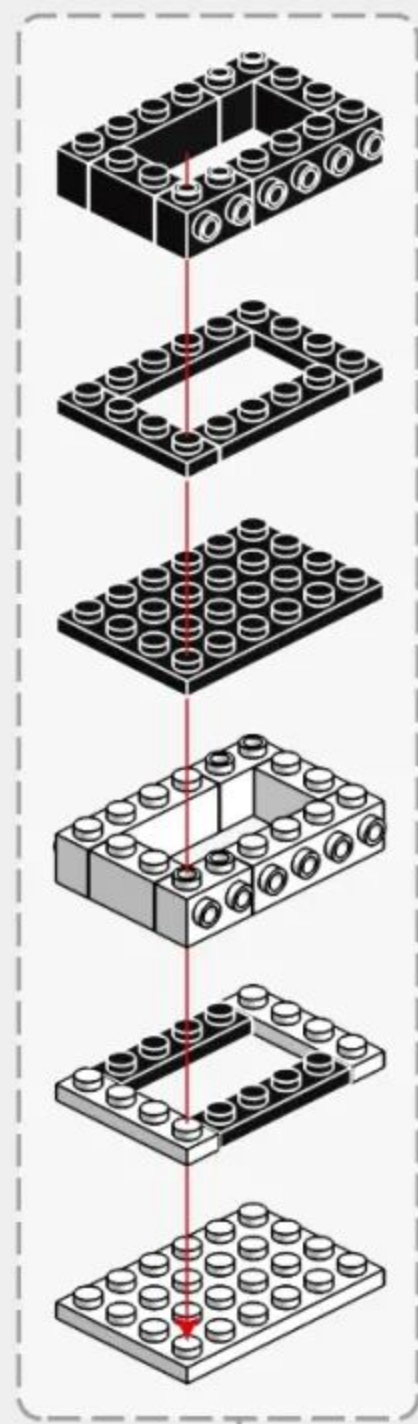
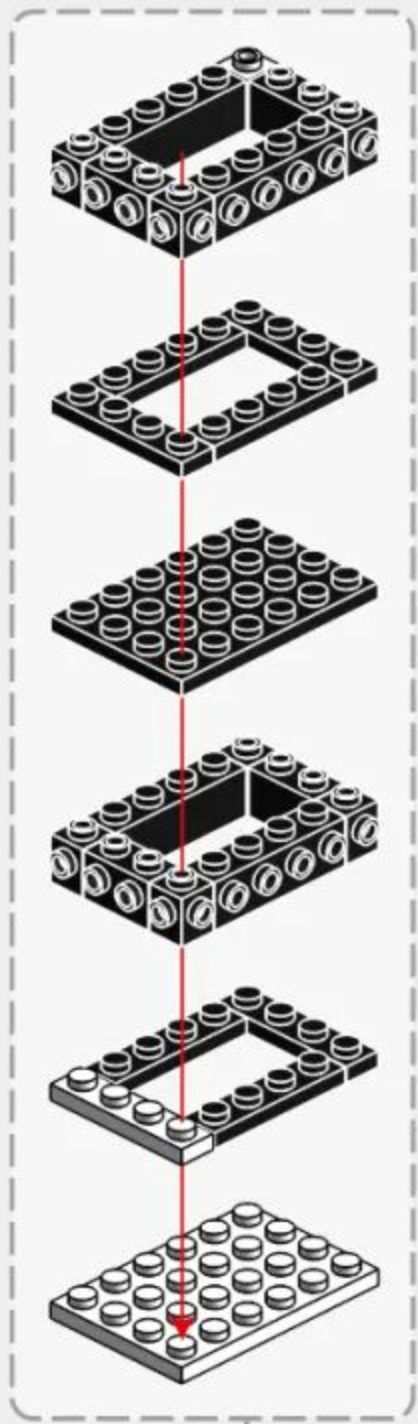
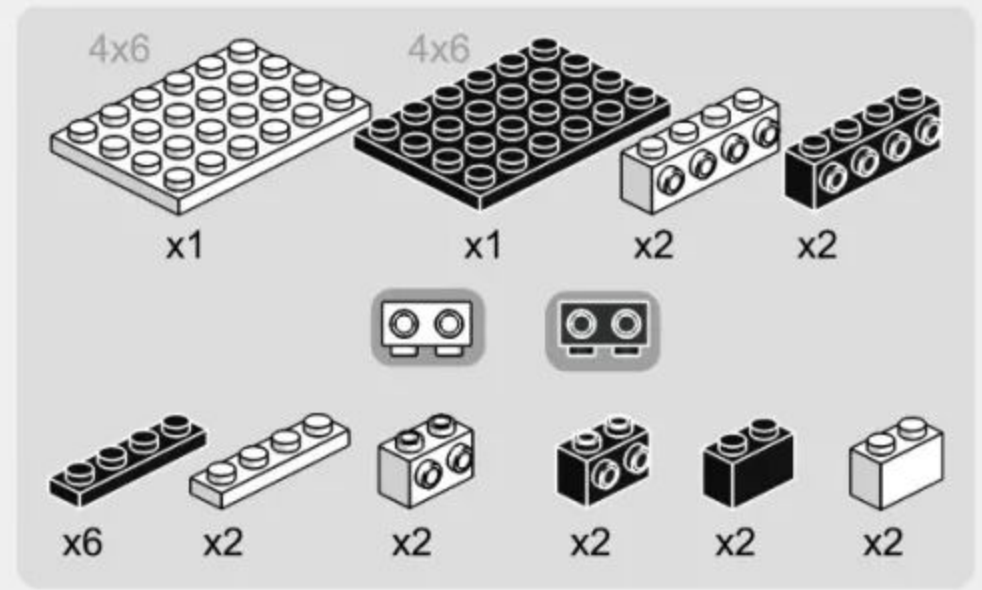

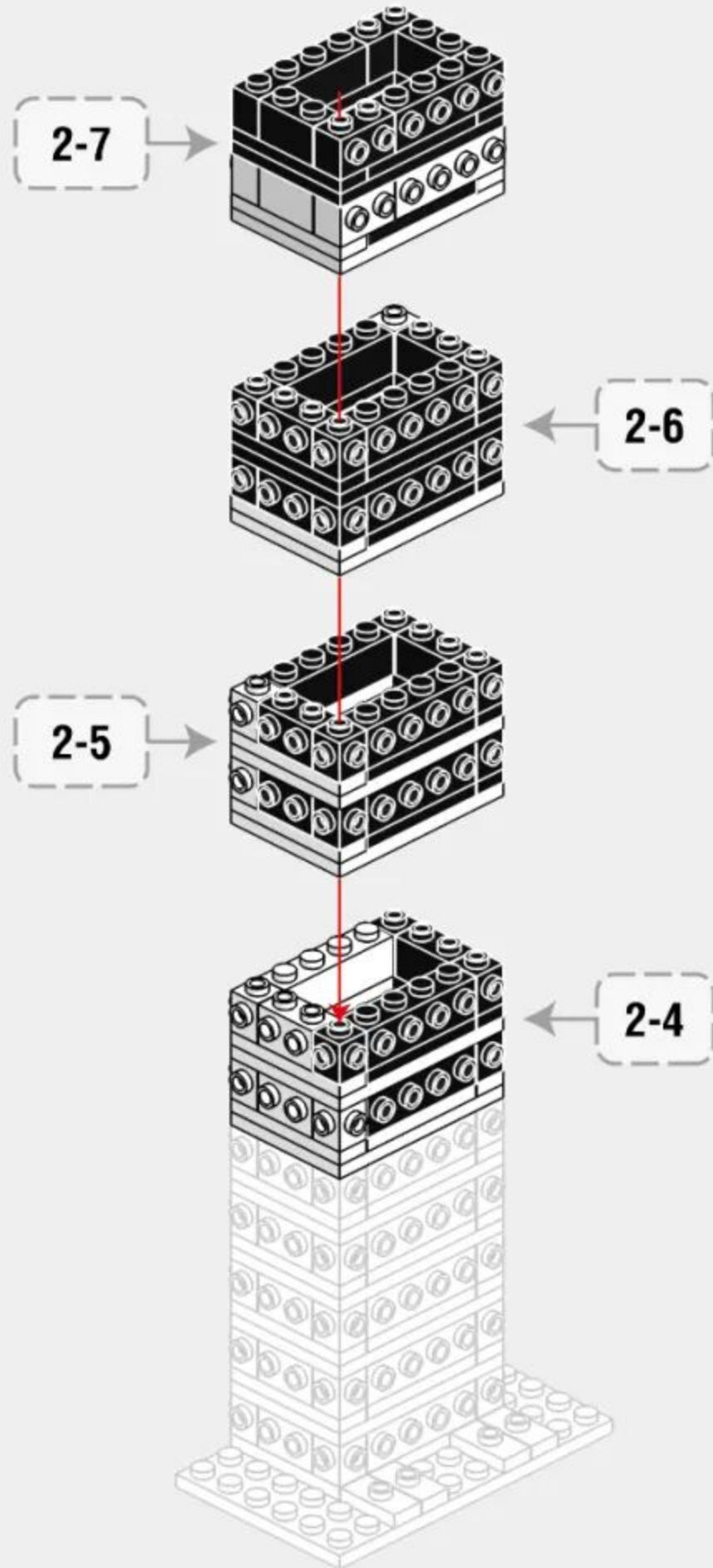

2-9

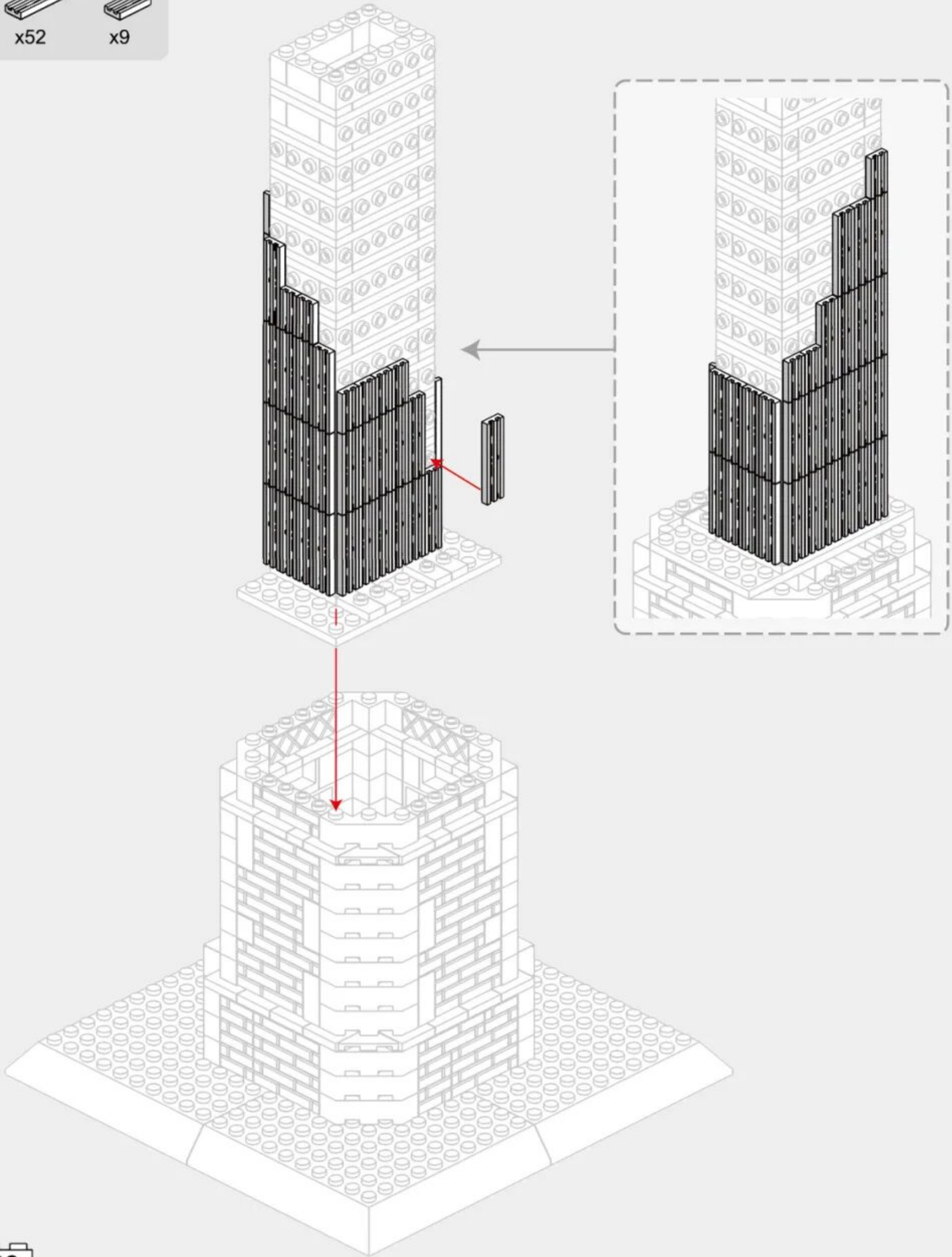
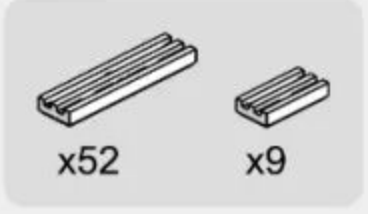

2-10

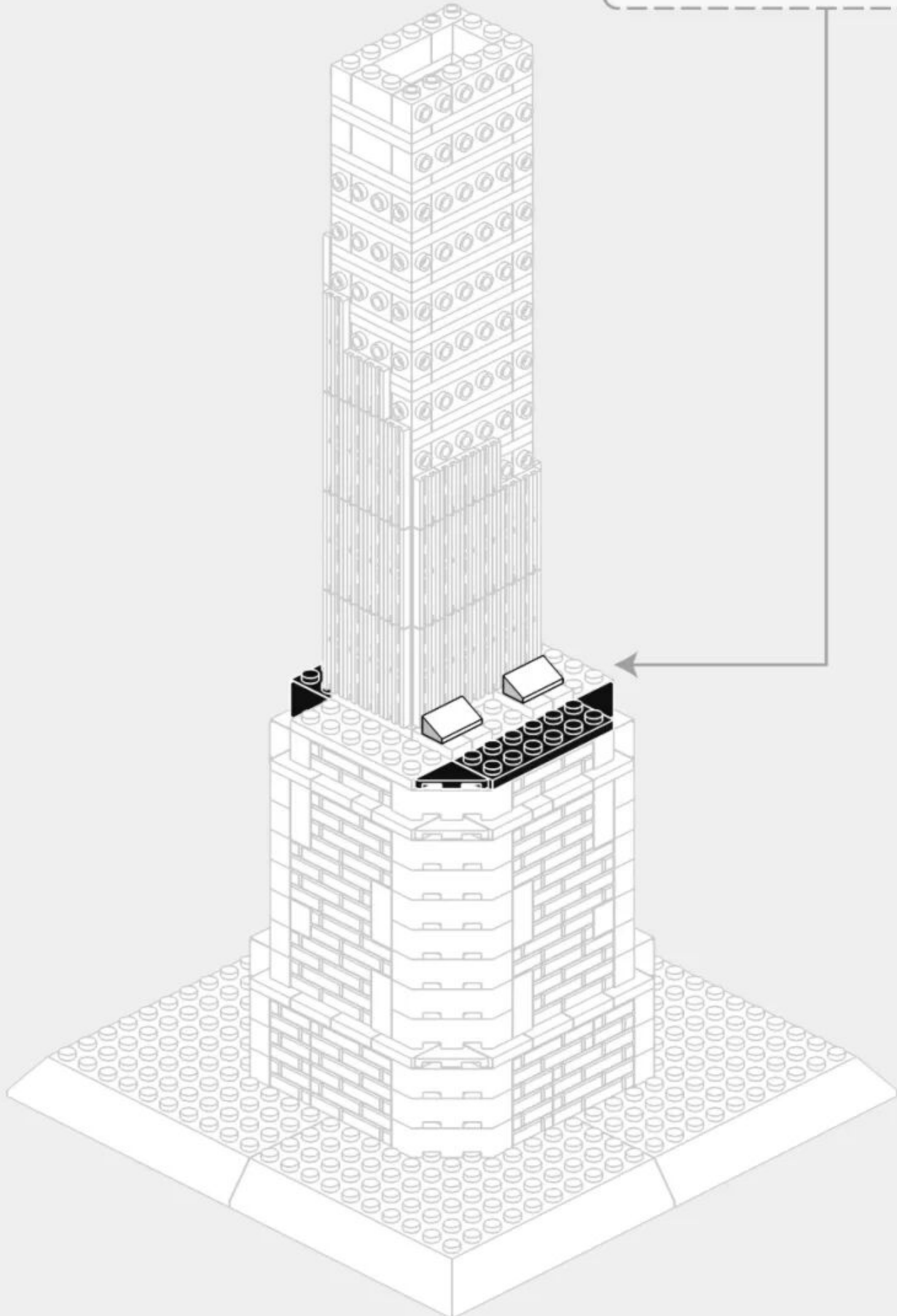
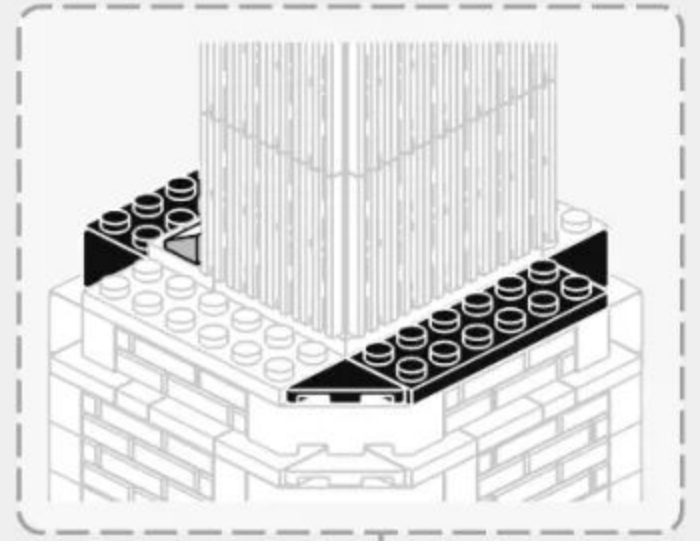
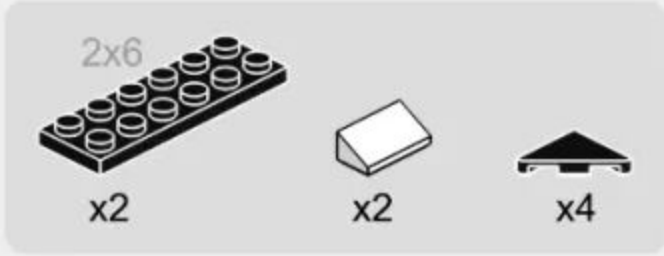

2-11

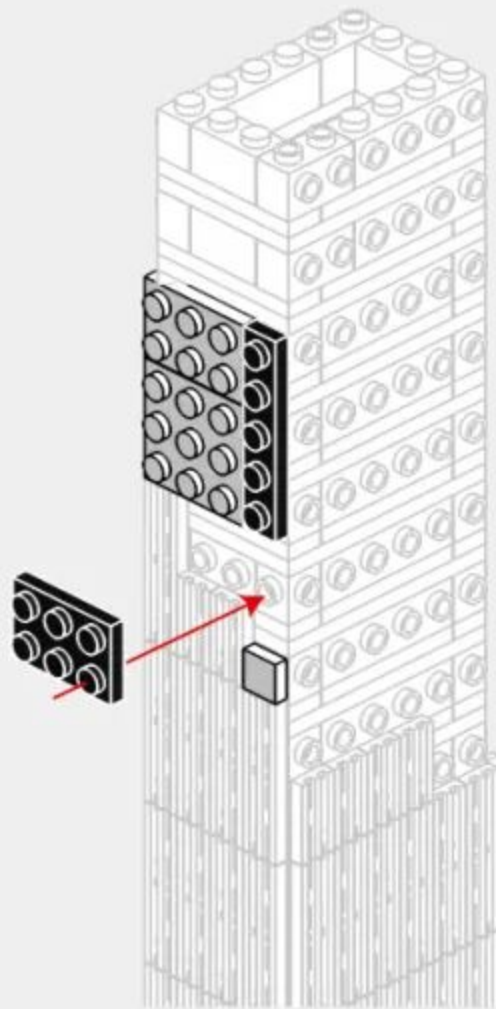
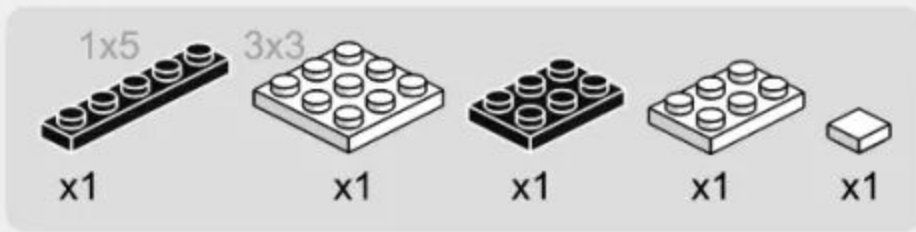

2-12

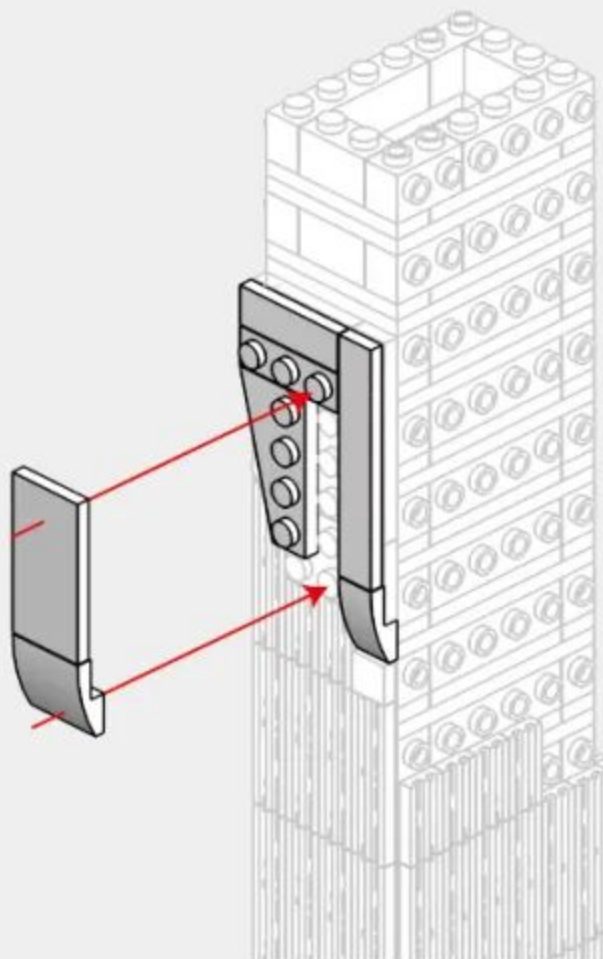
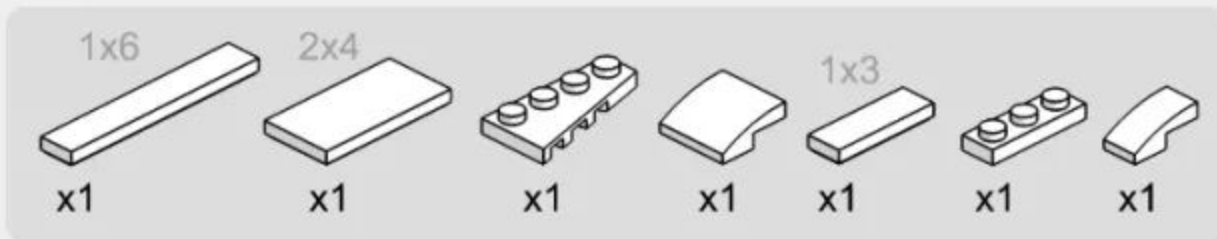

2-13

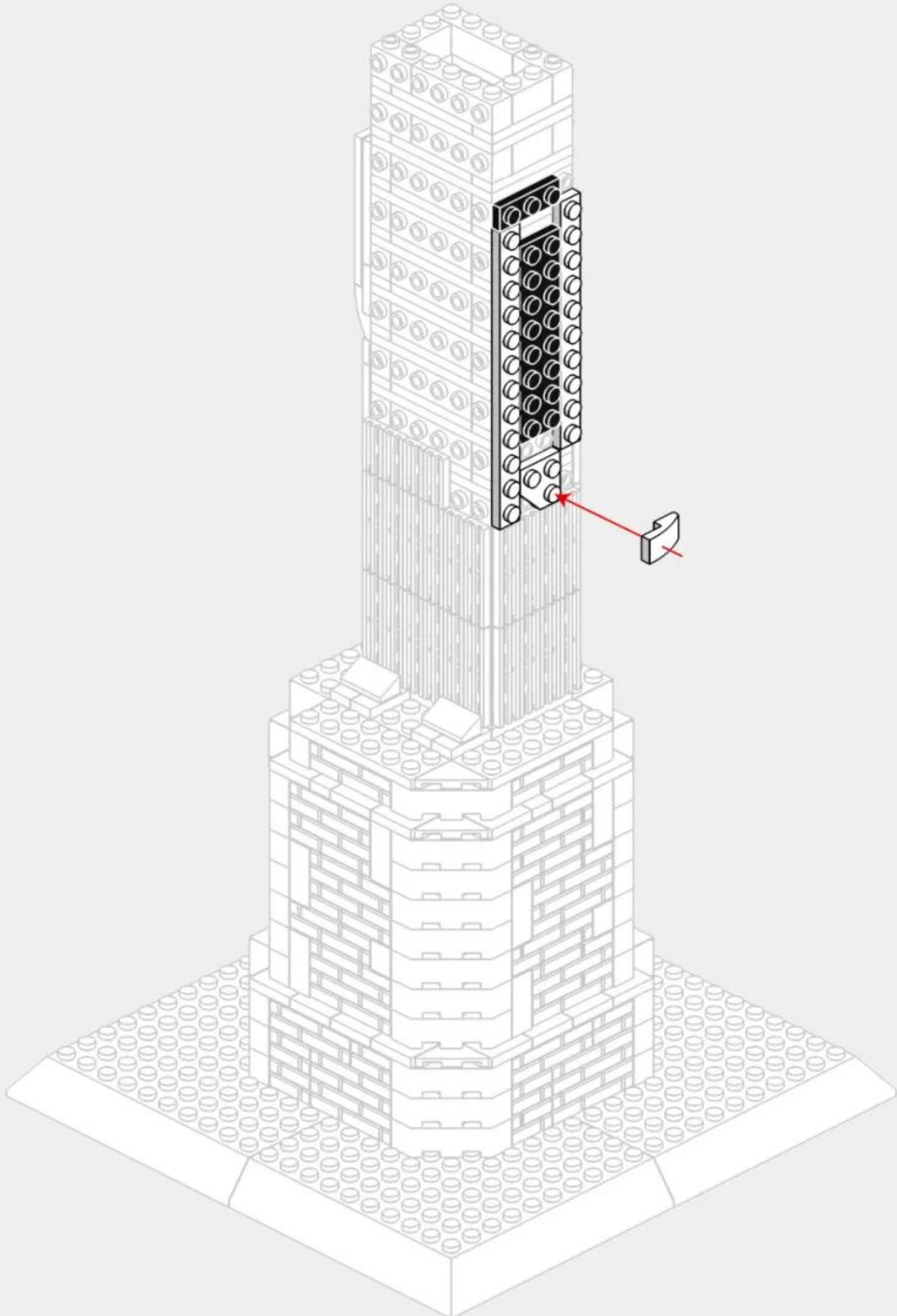
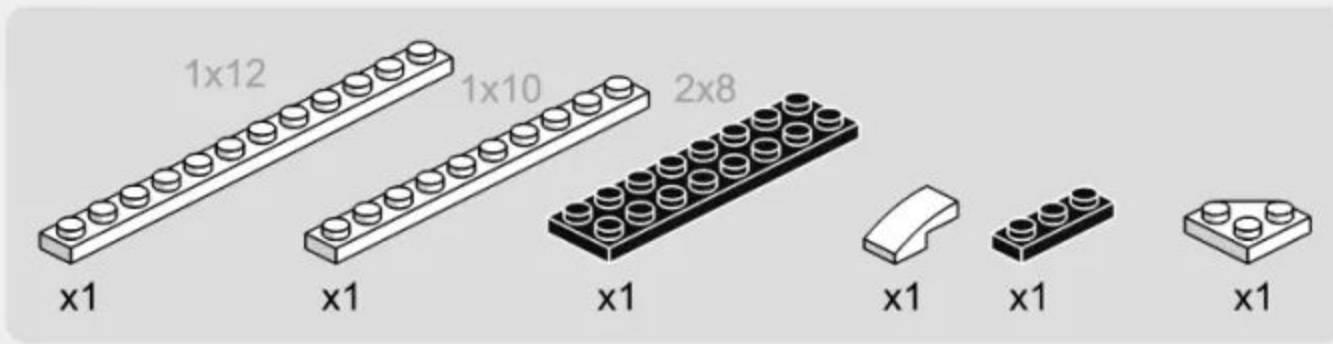

2-14

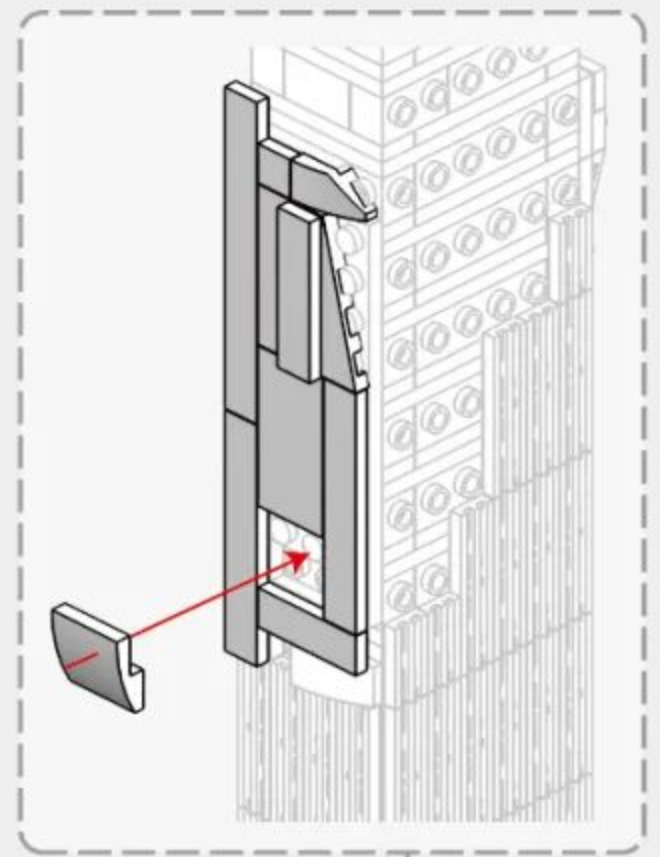
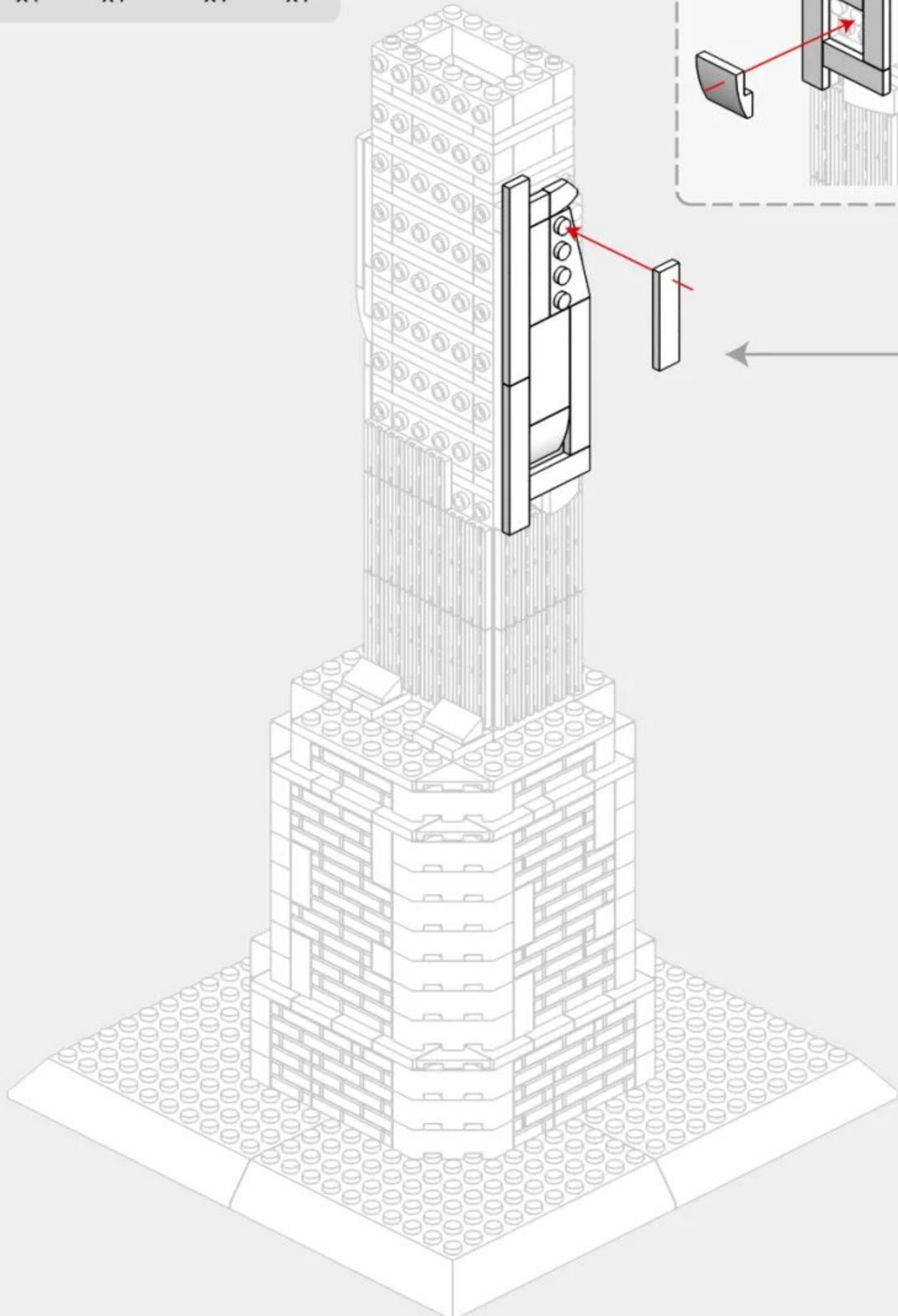
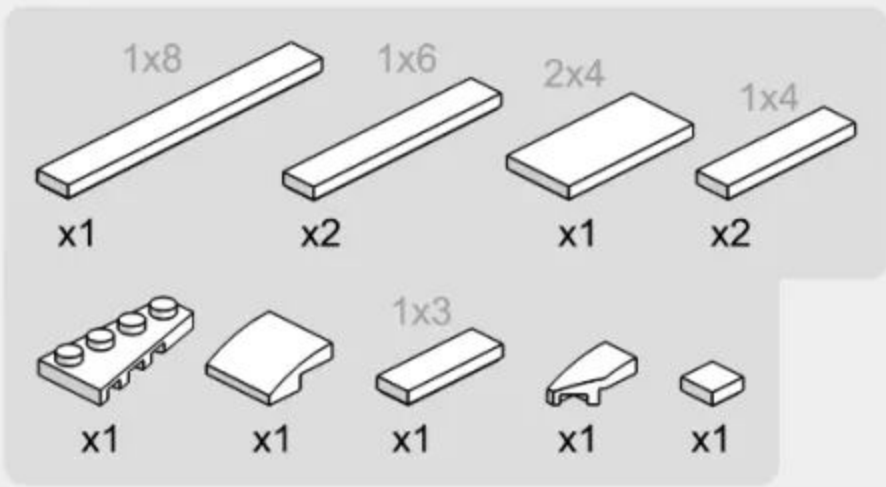



277 PCS

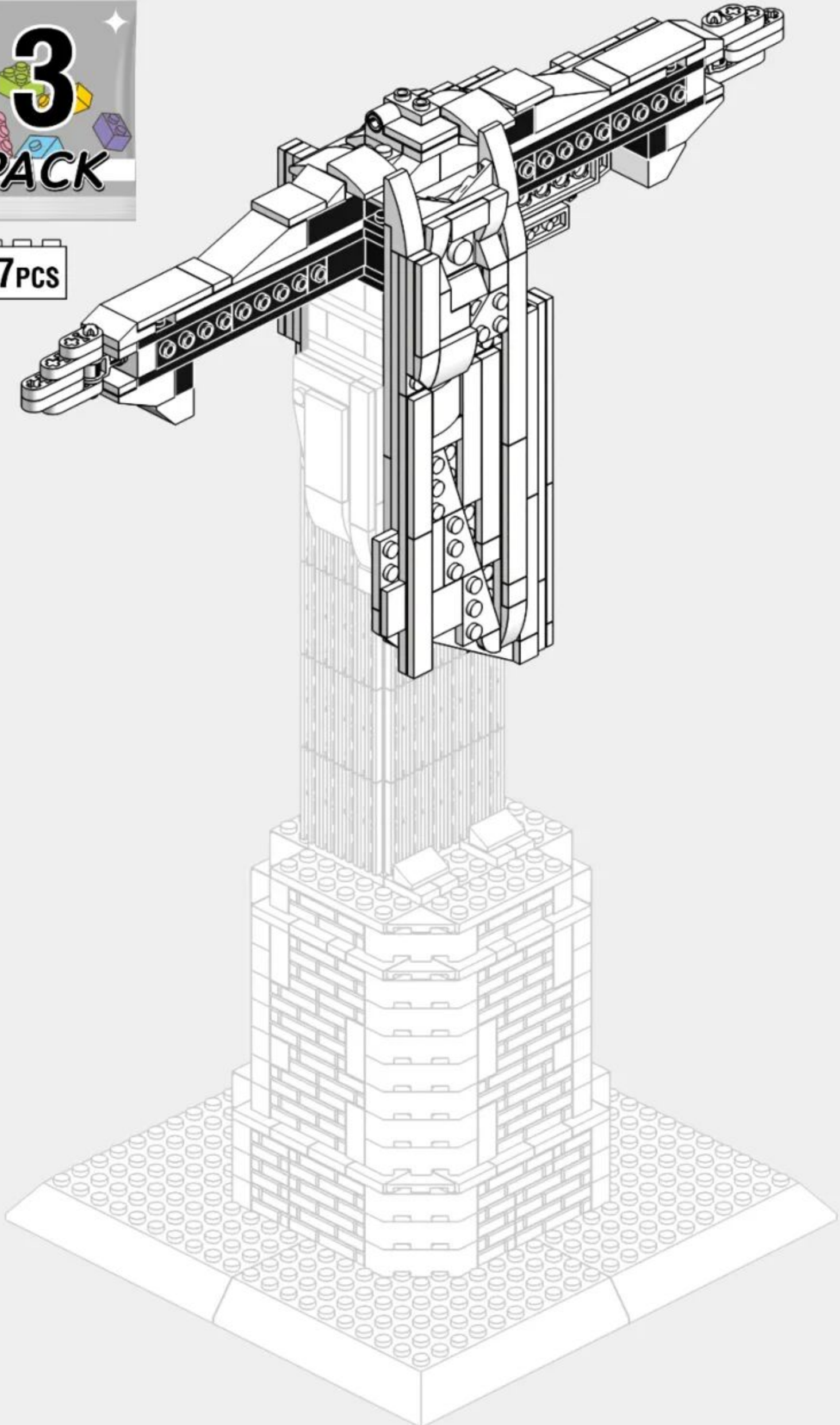

3-1

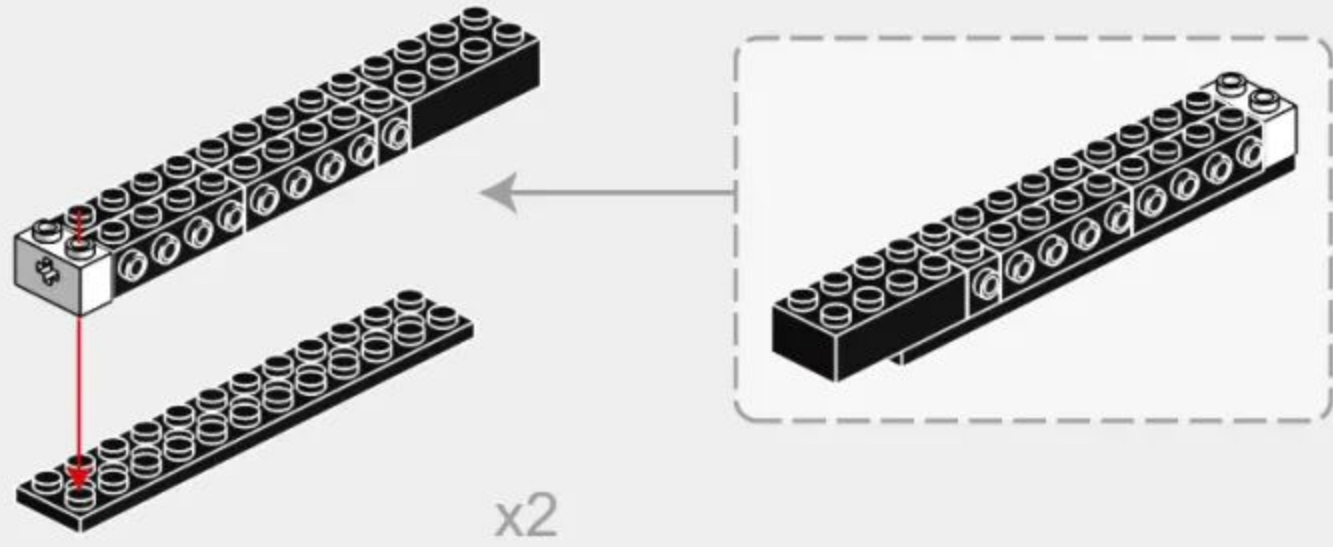
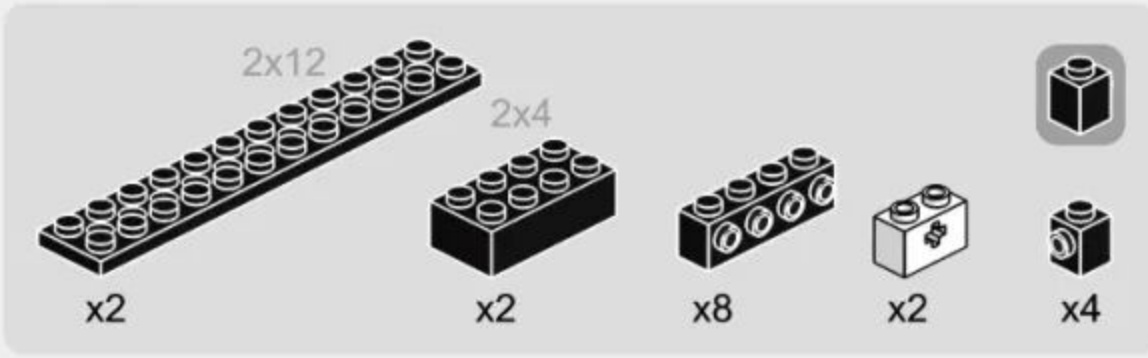

3-2

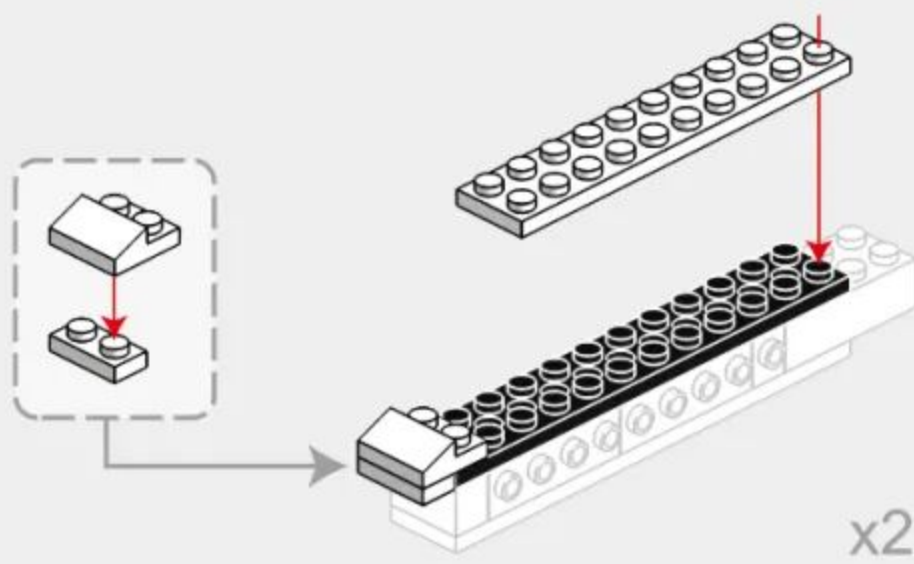
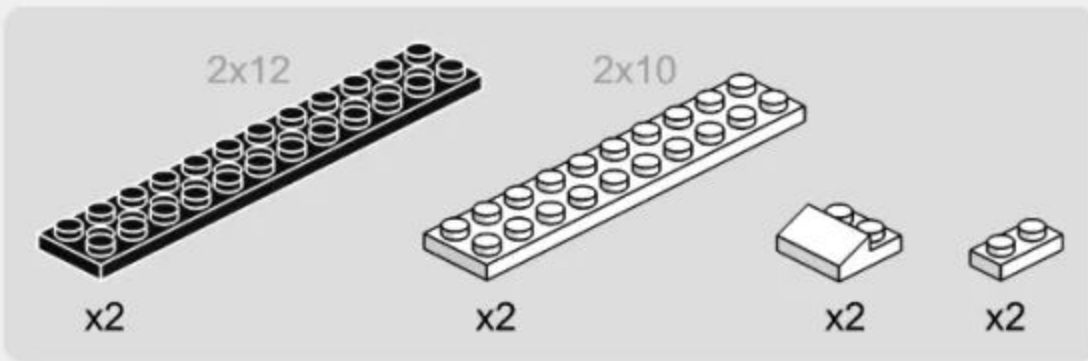

3-3

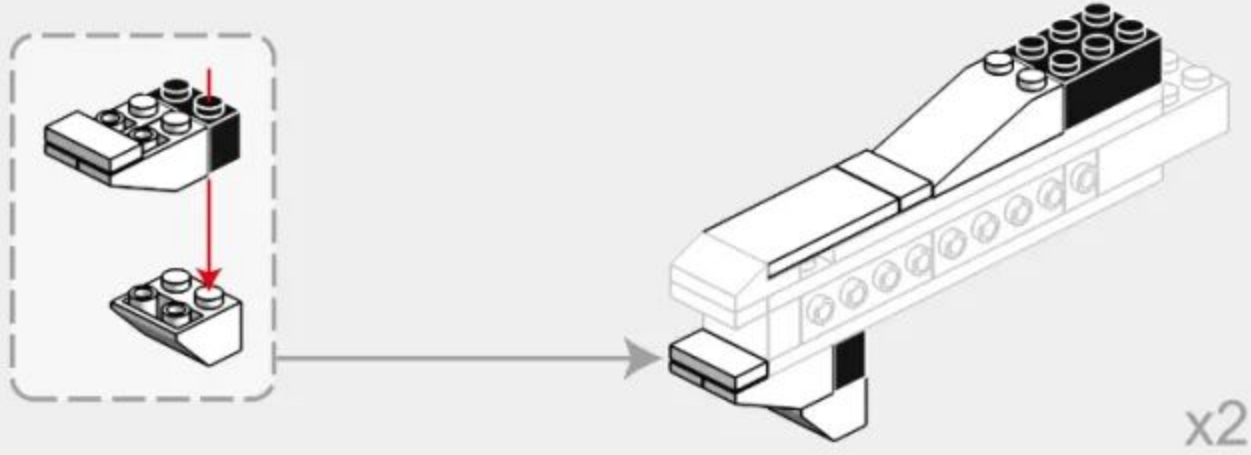
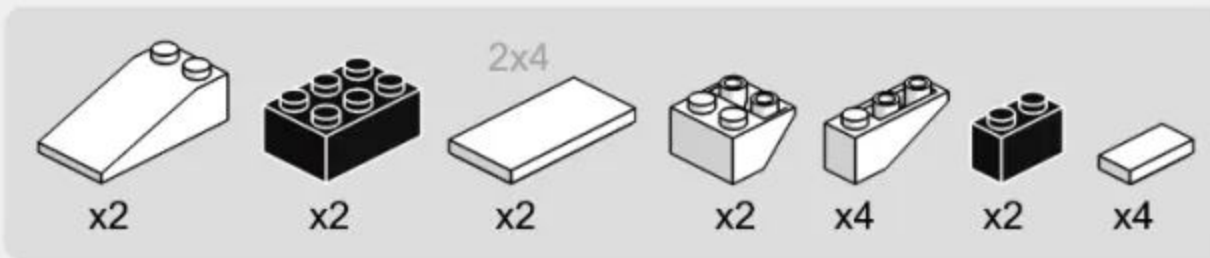

3-4

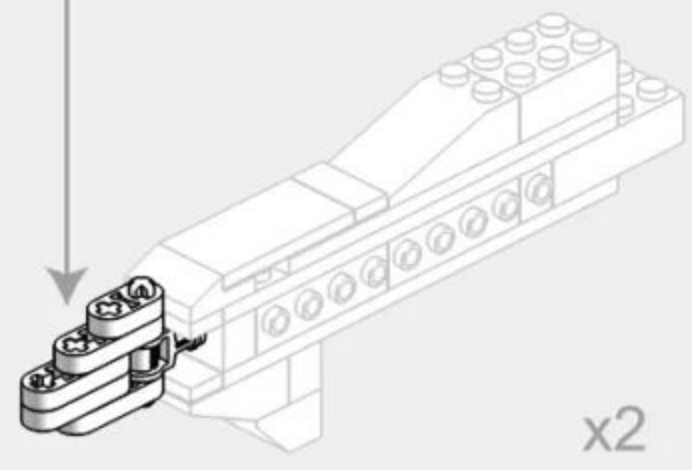
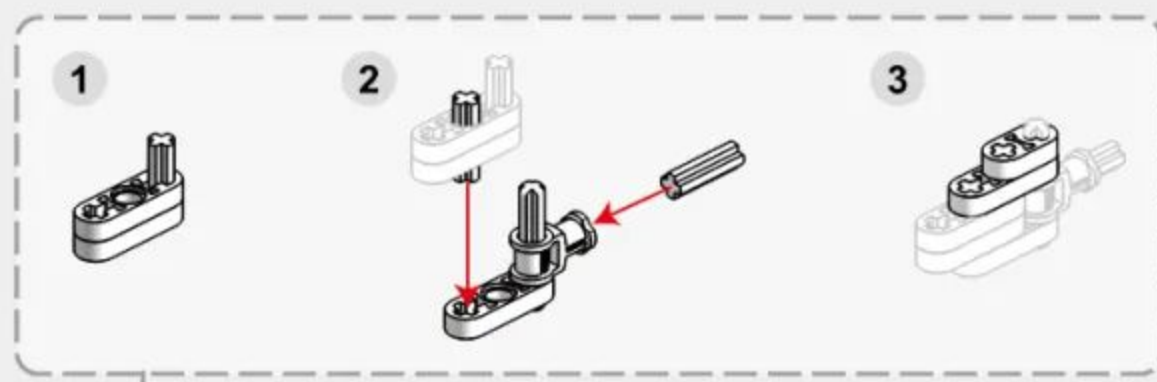

3-5

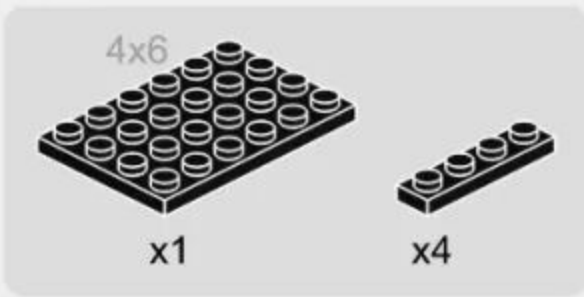

1

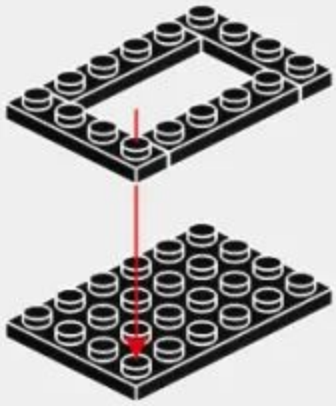

2

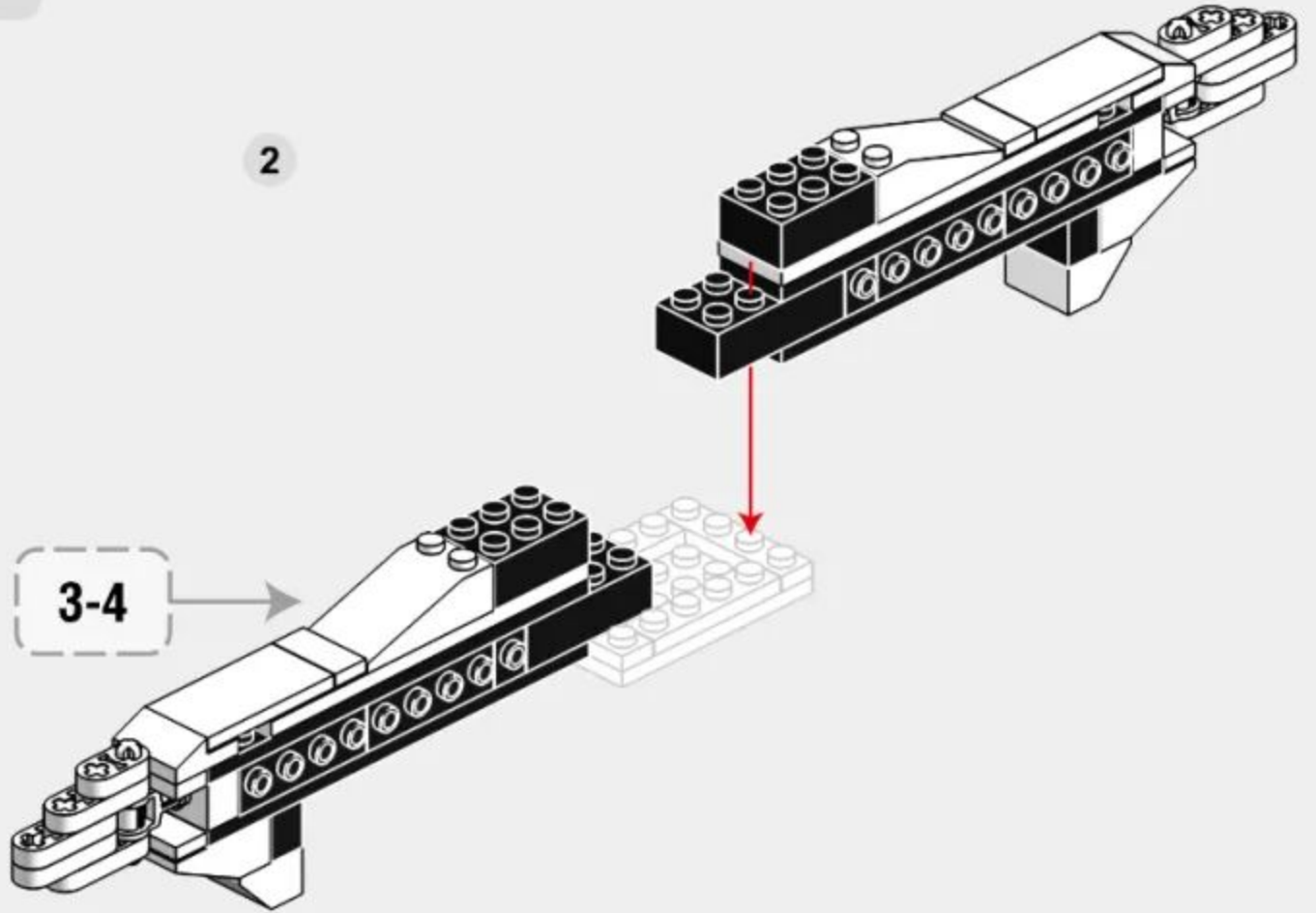

3-6

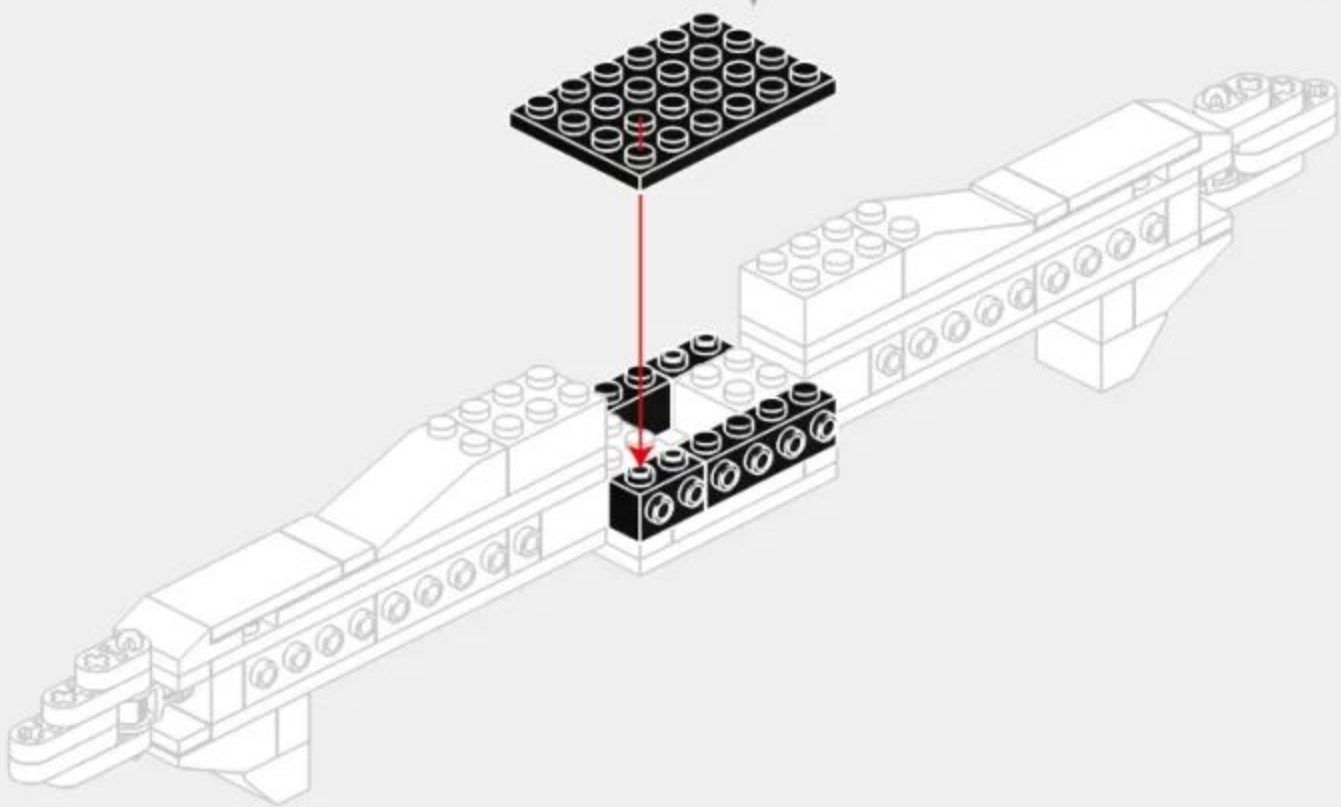
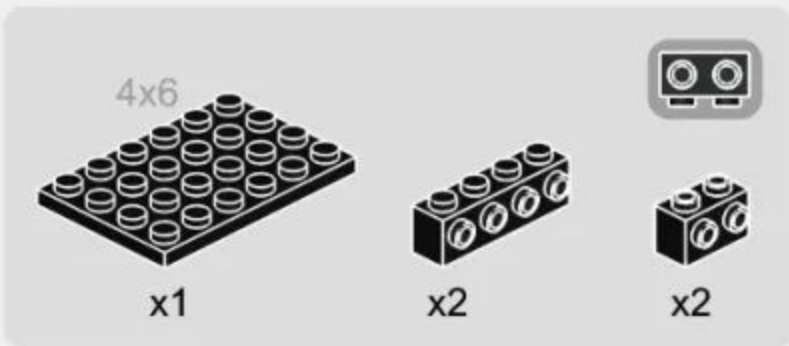

3-7

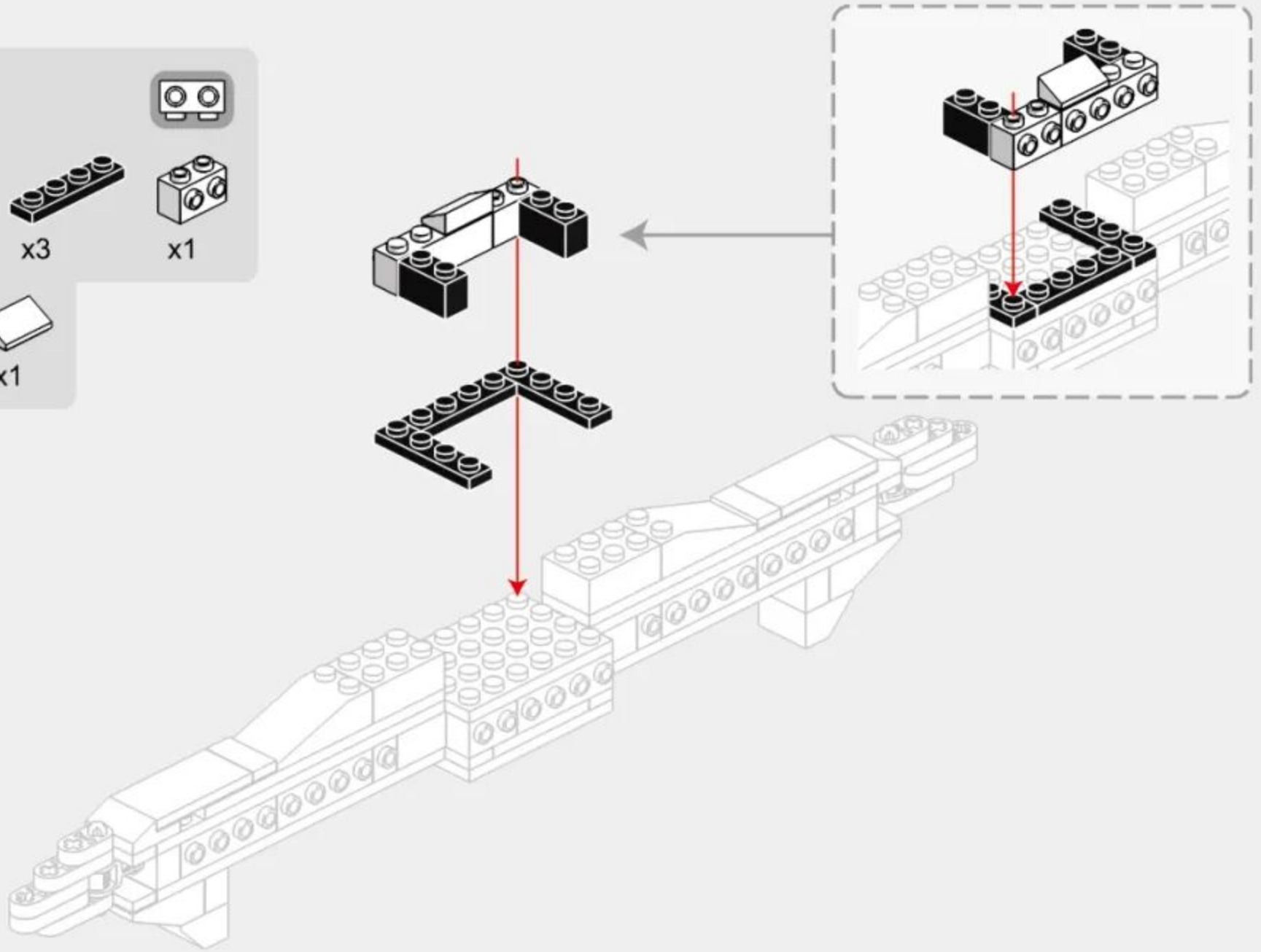
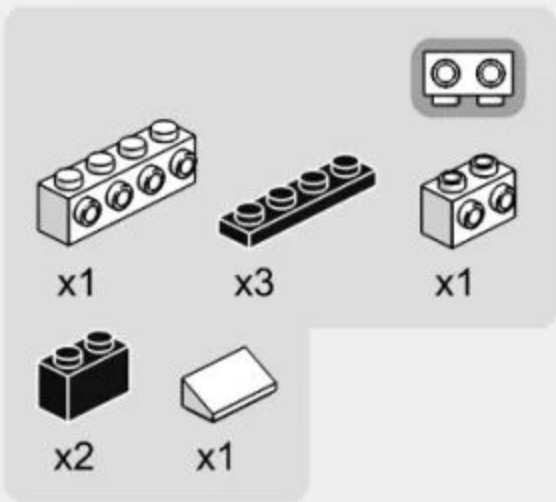

3-8

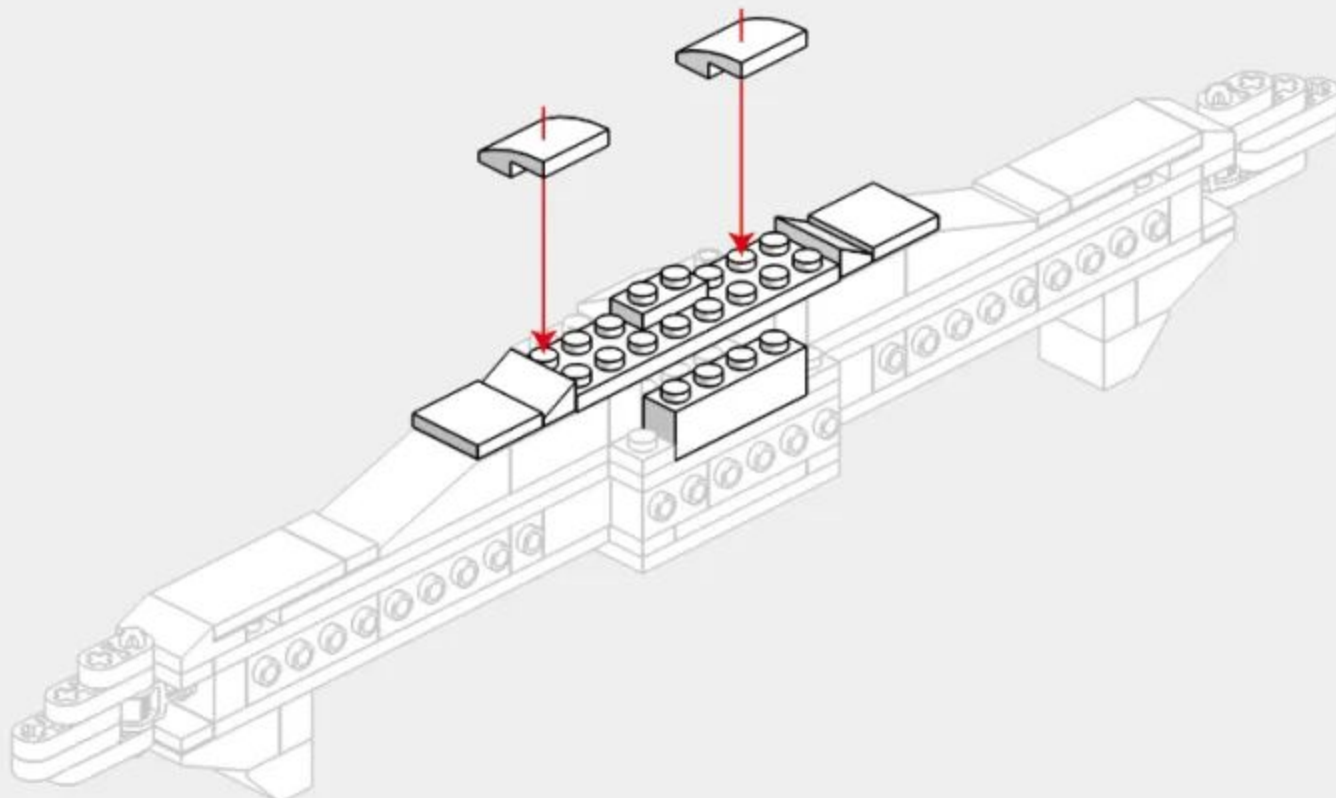
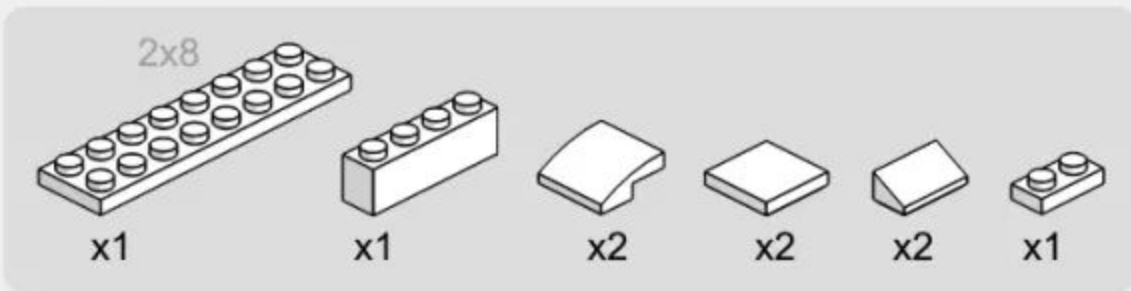

3-9

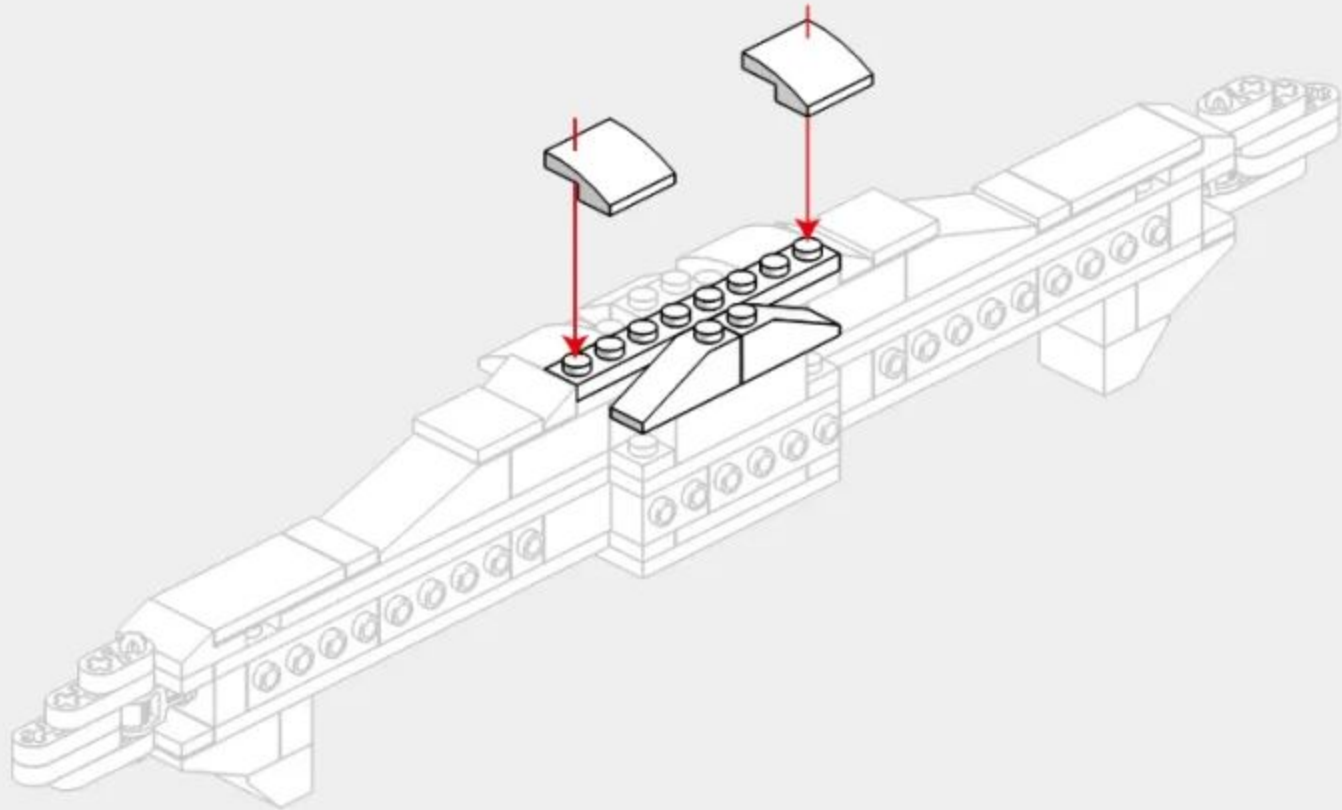
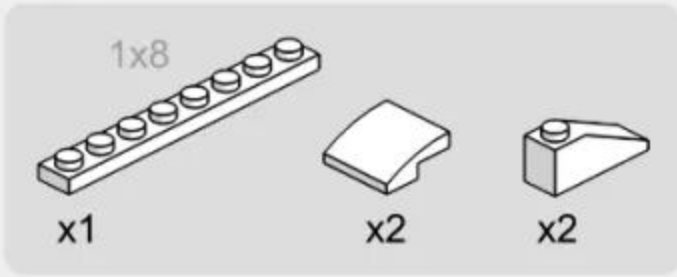

3-10

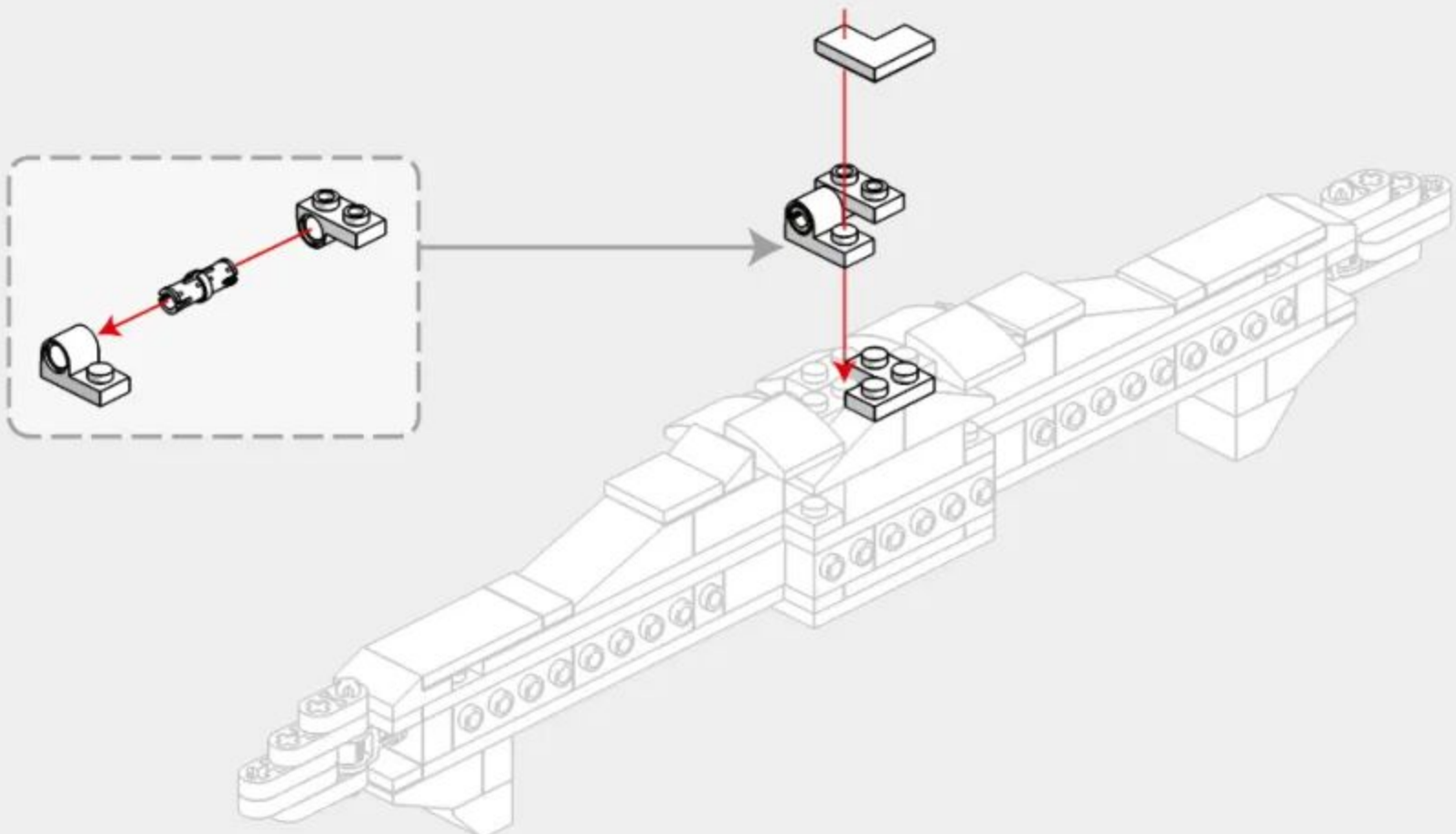
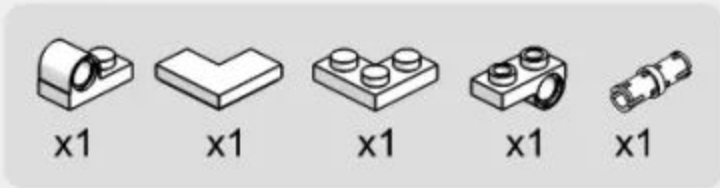

3-11

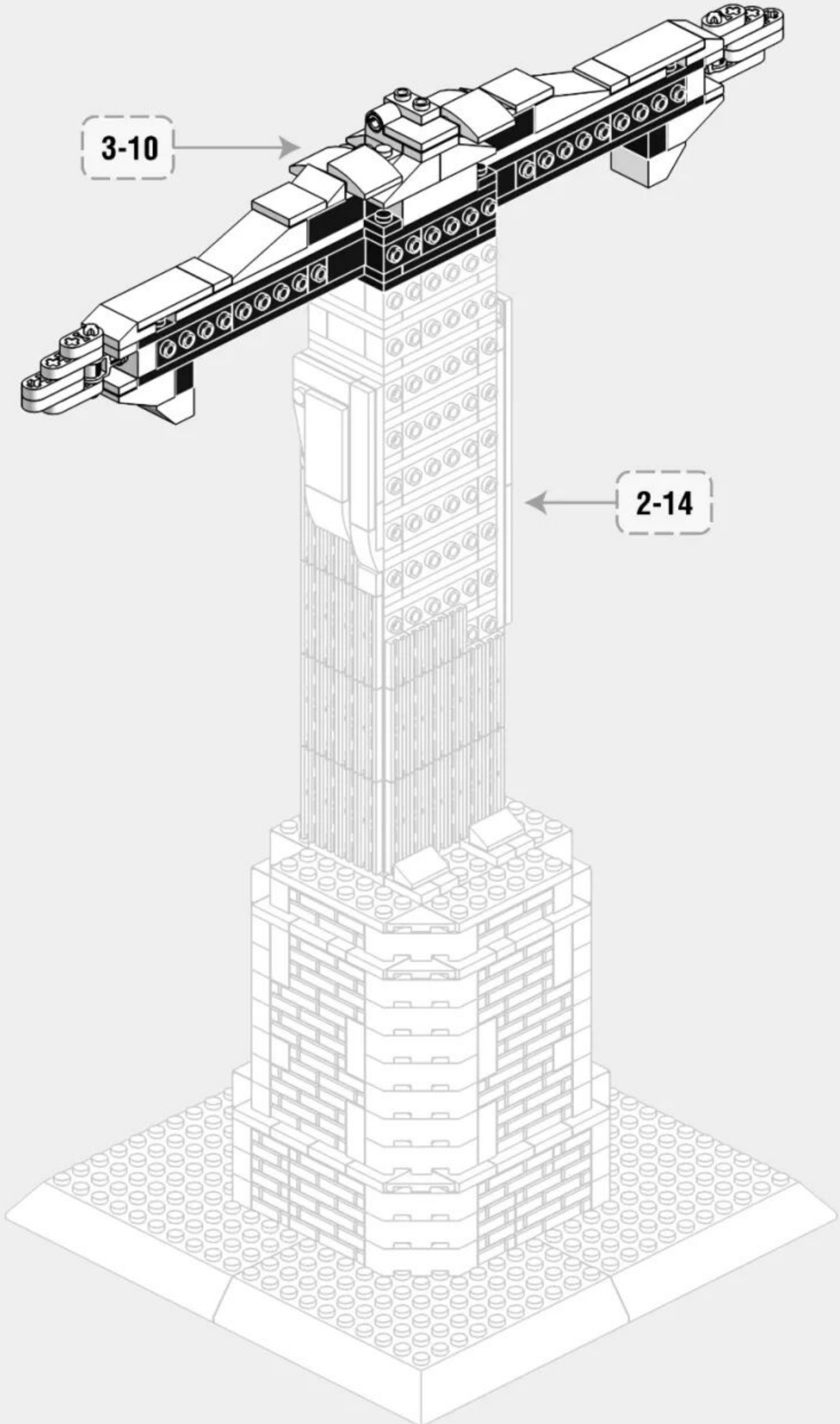

3-12

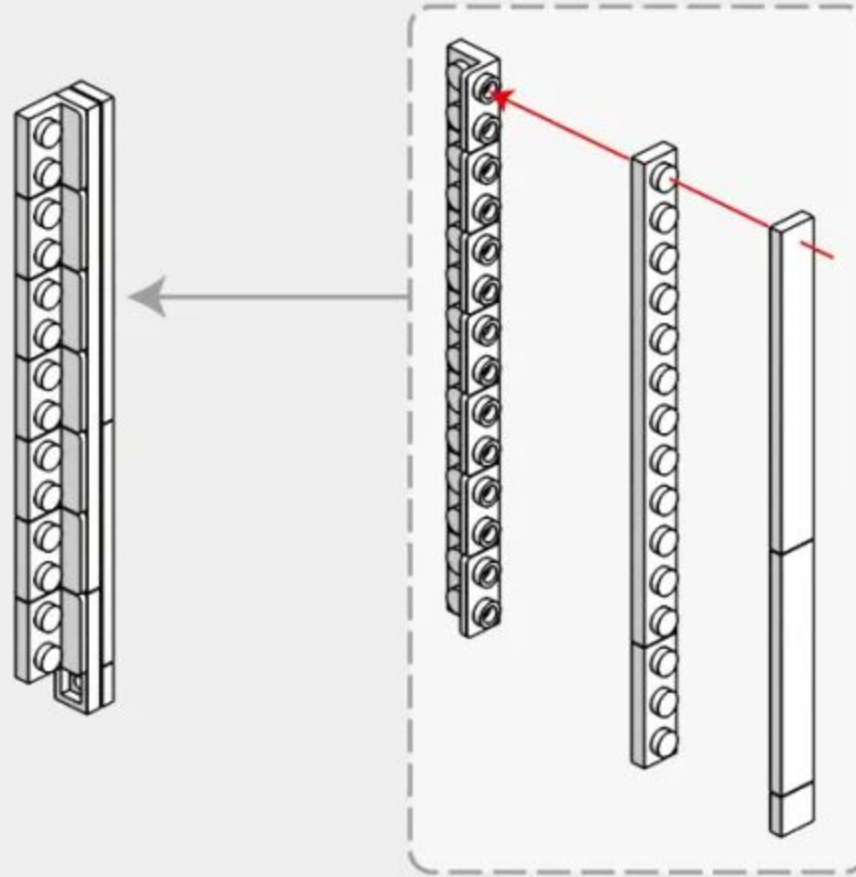
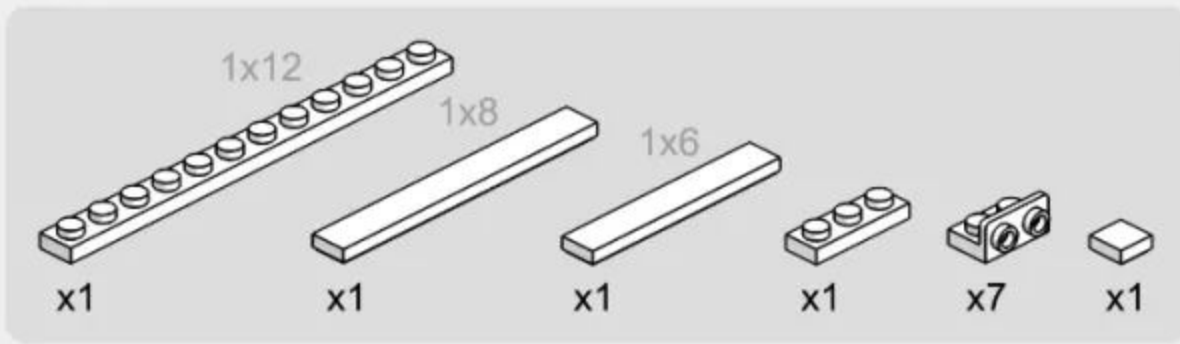

3-13

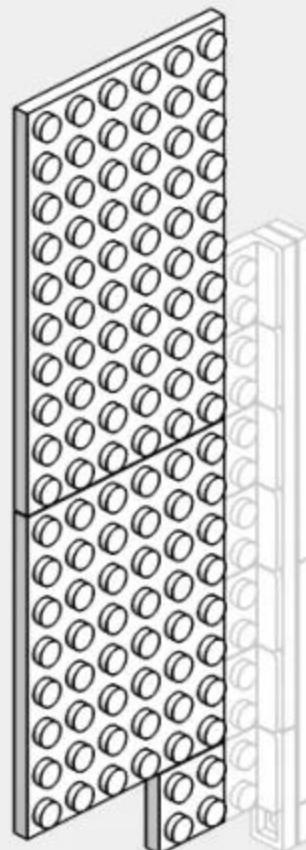
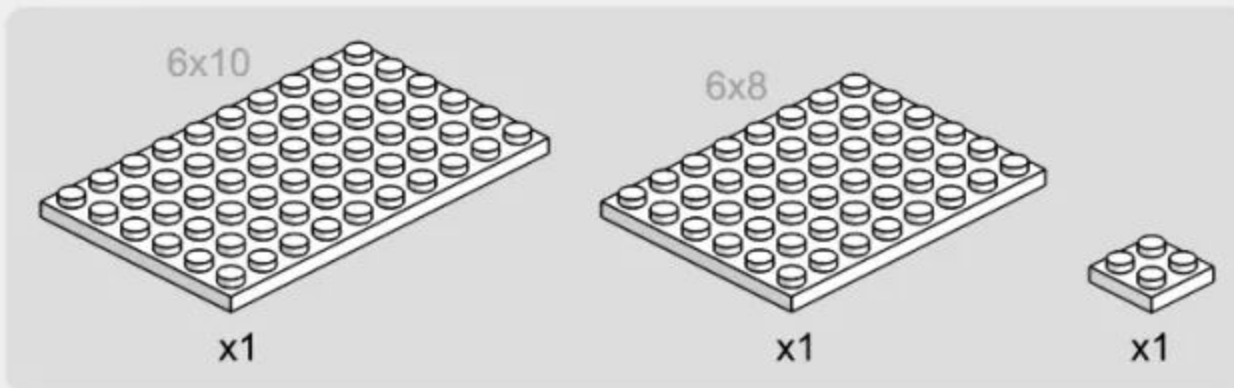

3-16

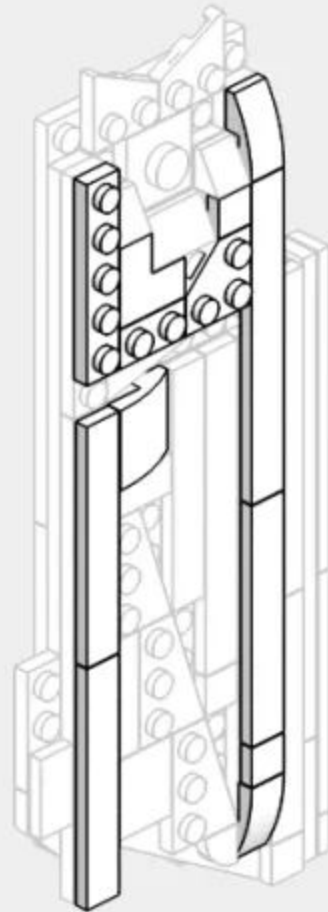
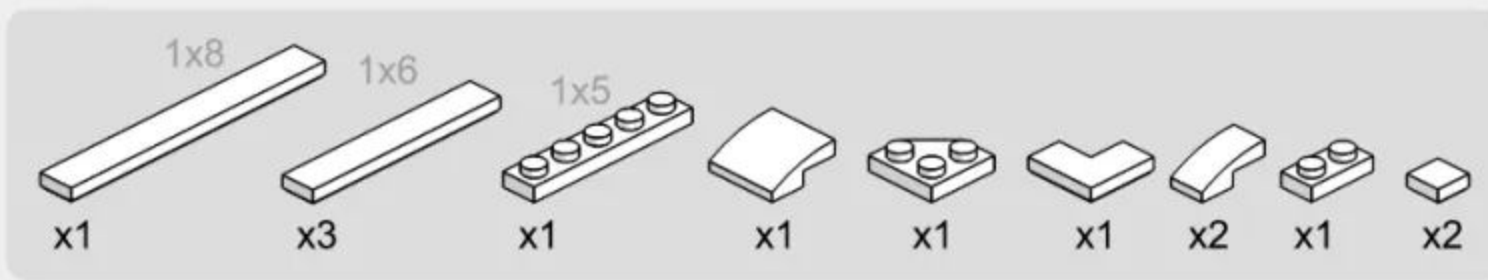

3-17

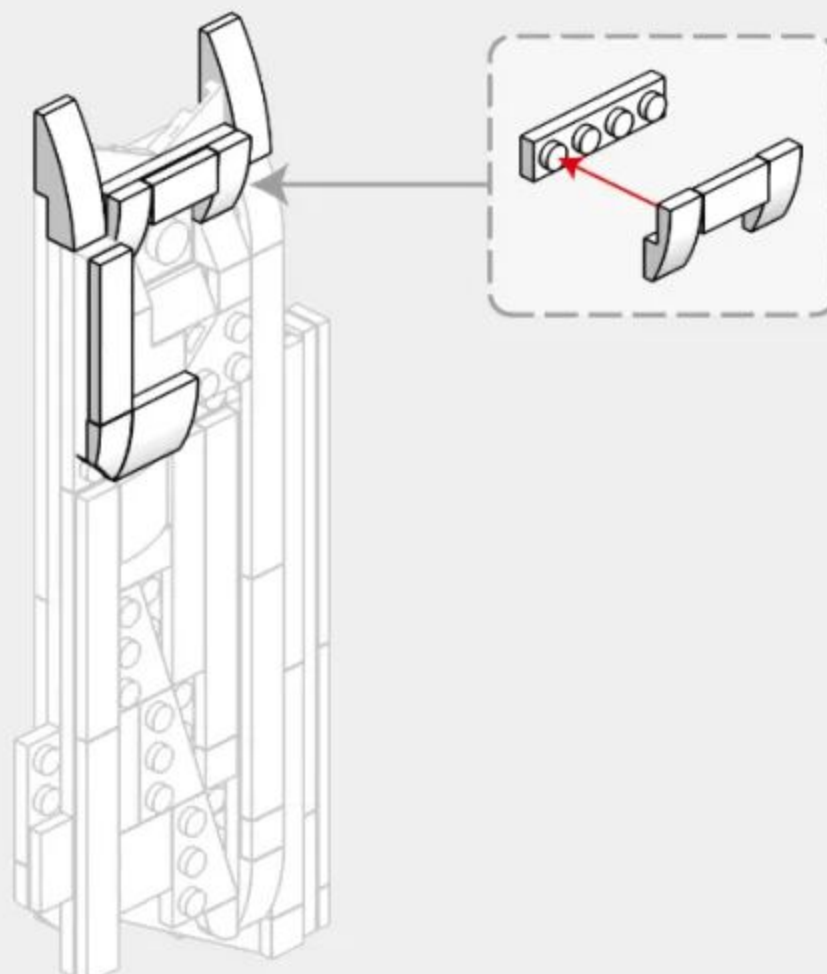
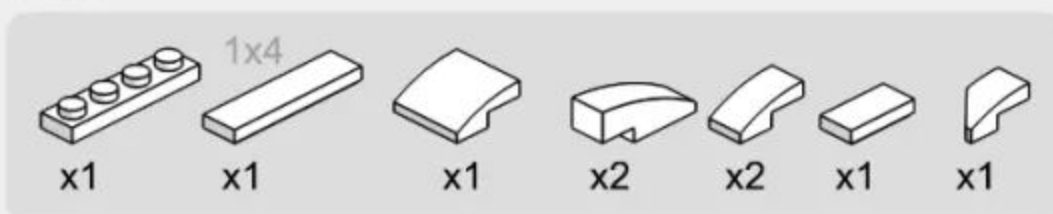

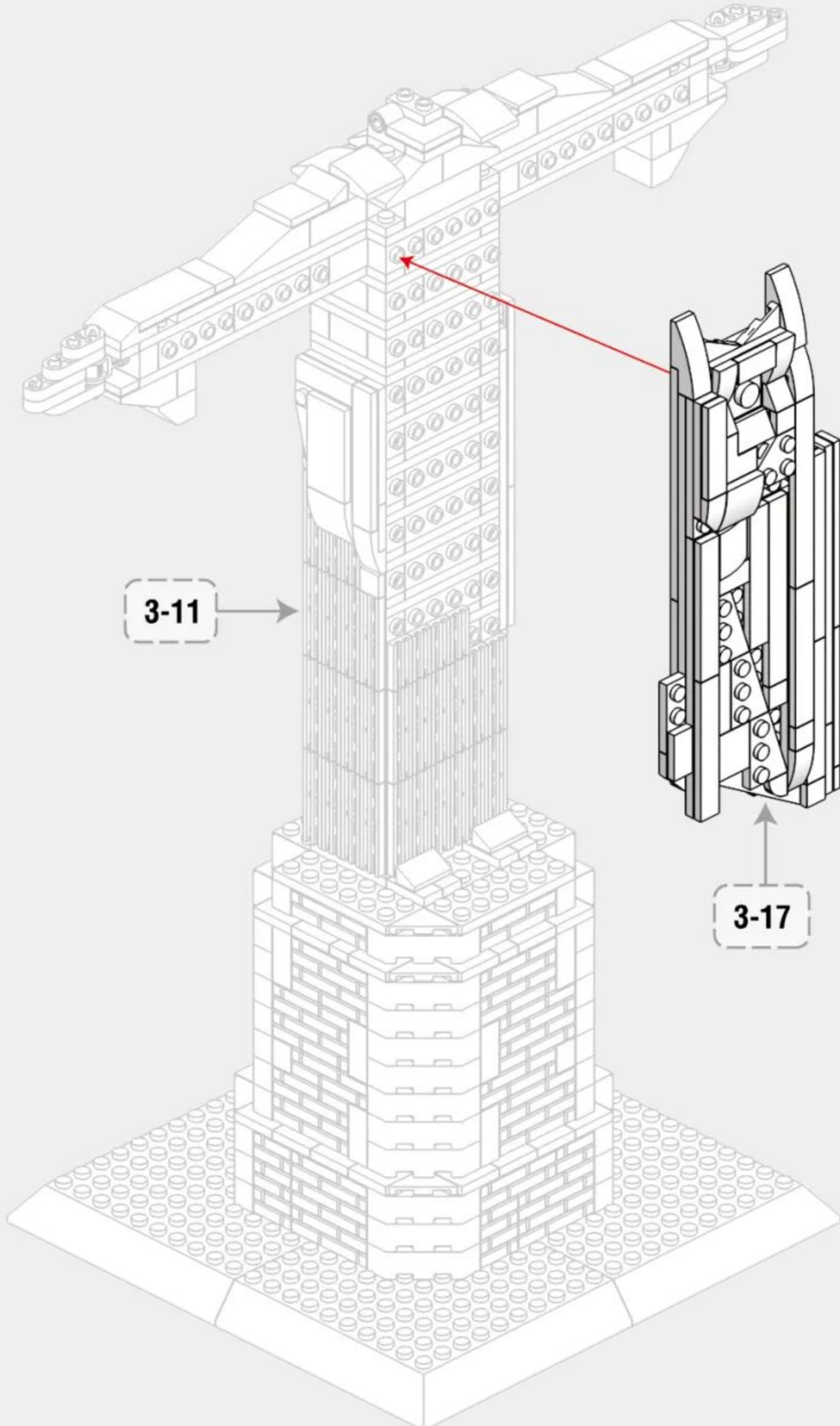

3-19

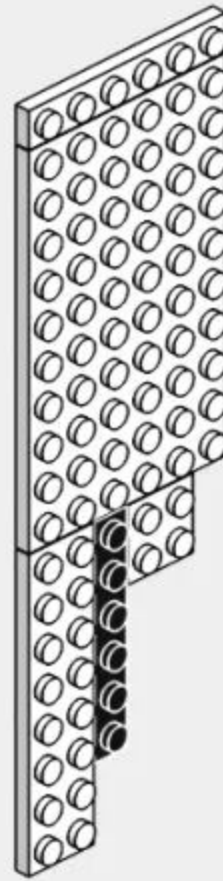
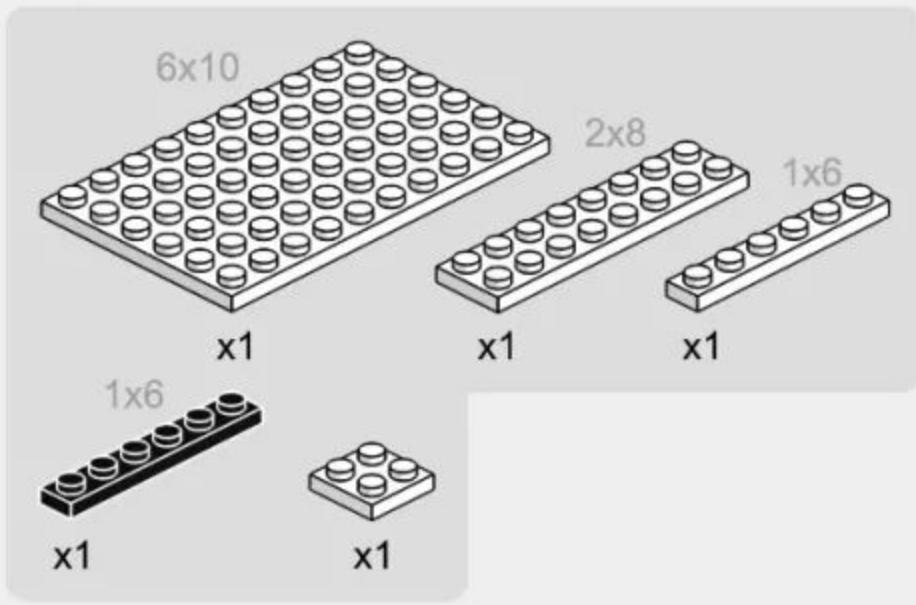

3-20

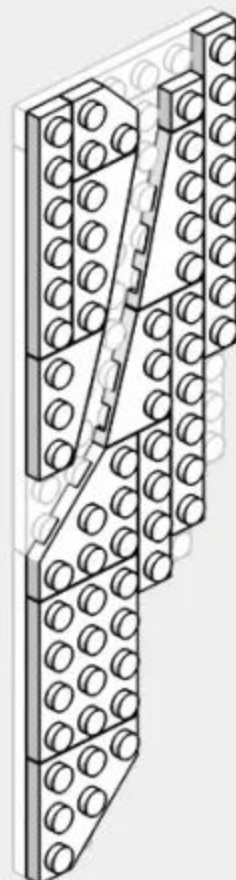
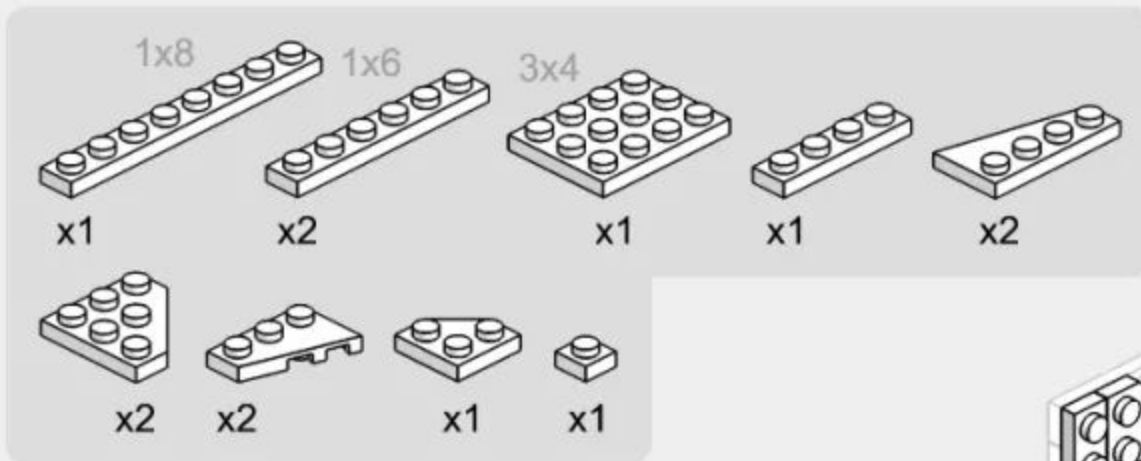

3-21

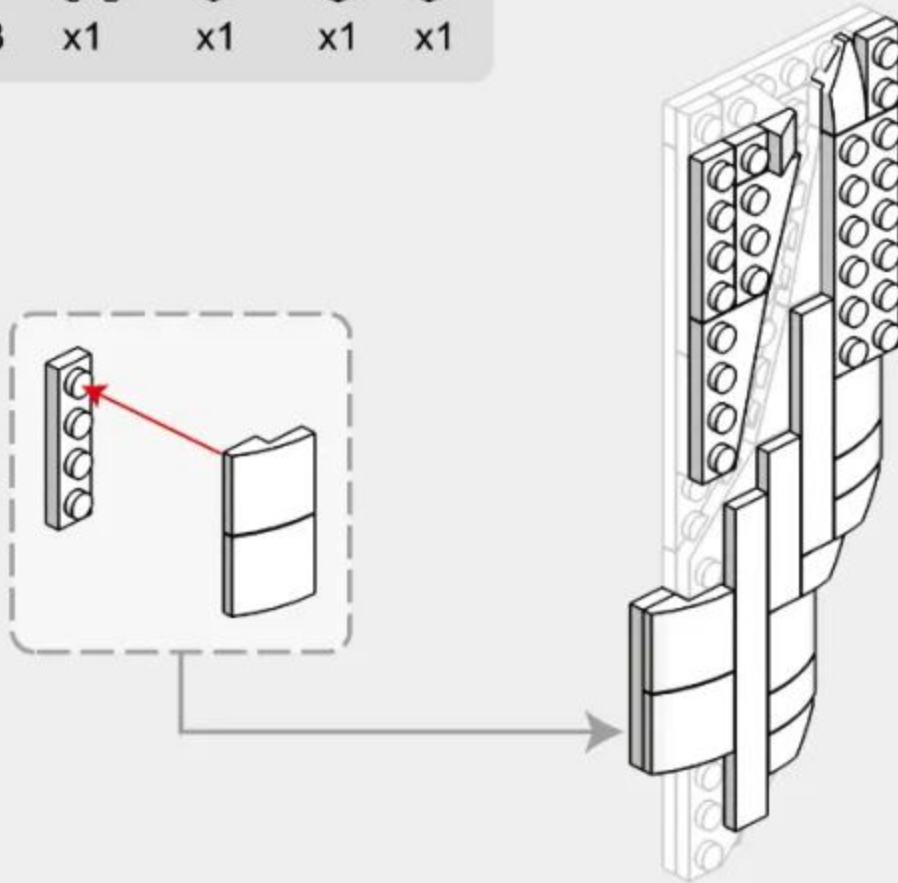
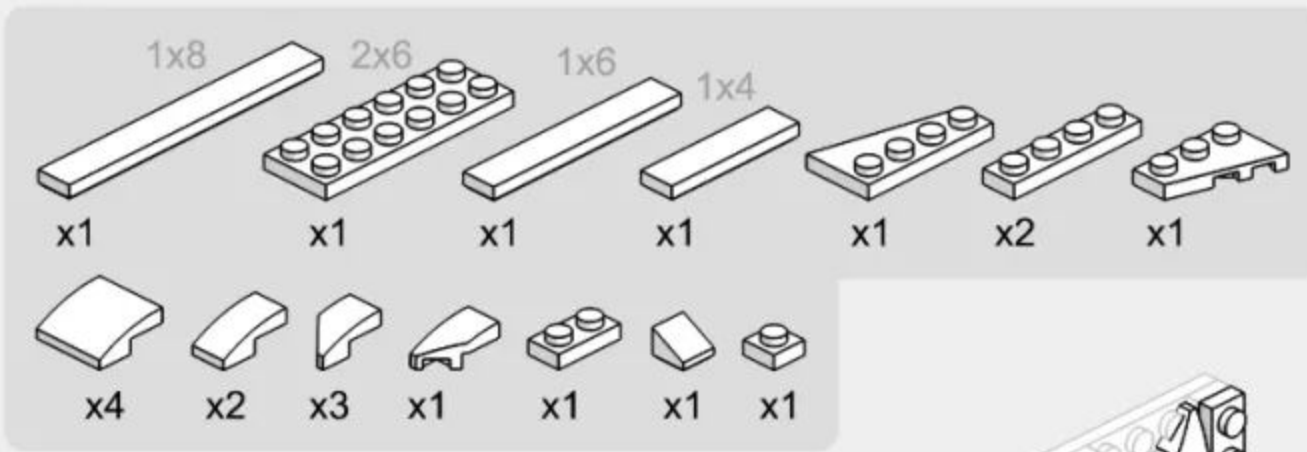

3-22

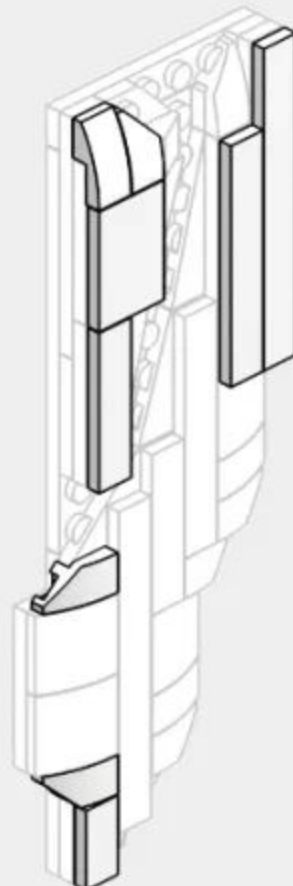
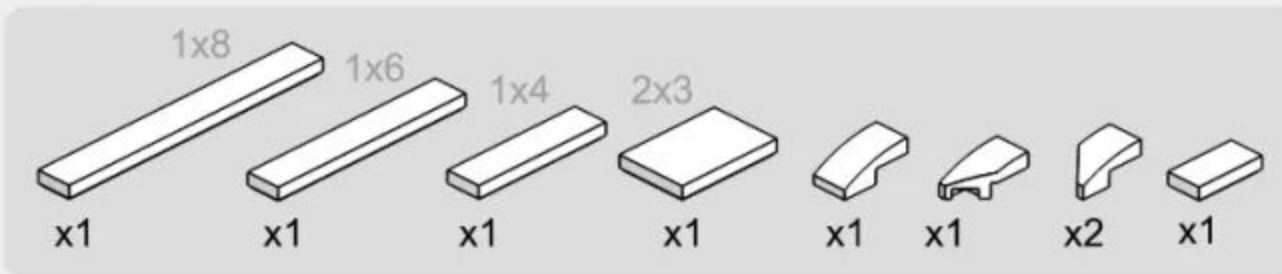

3-23

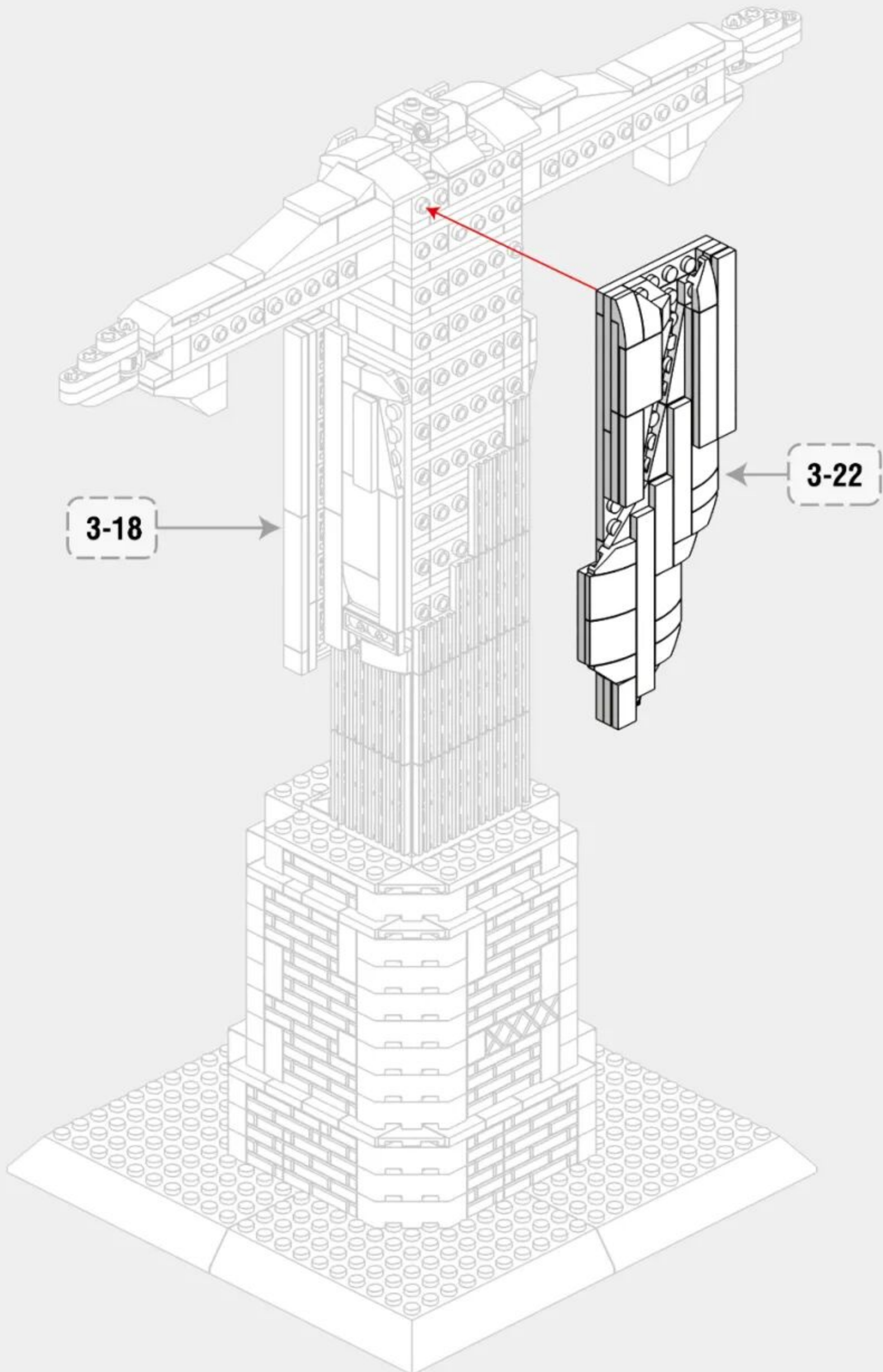

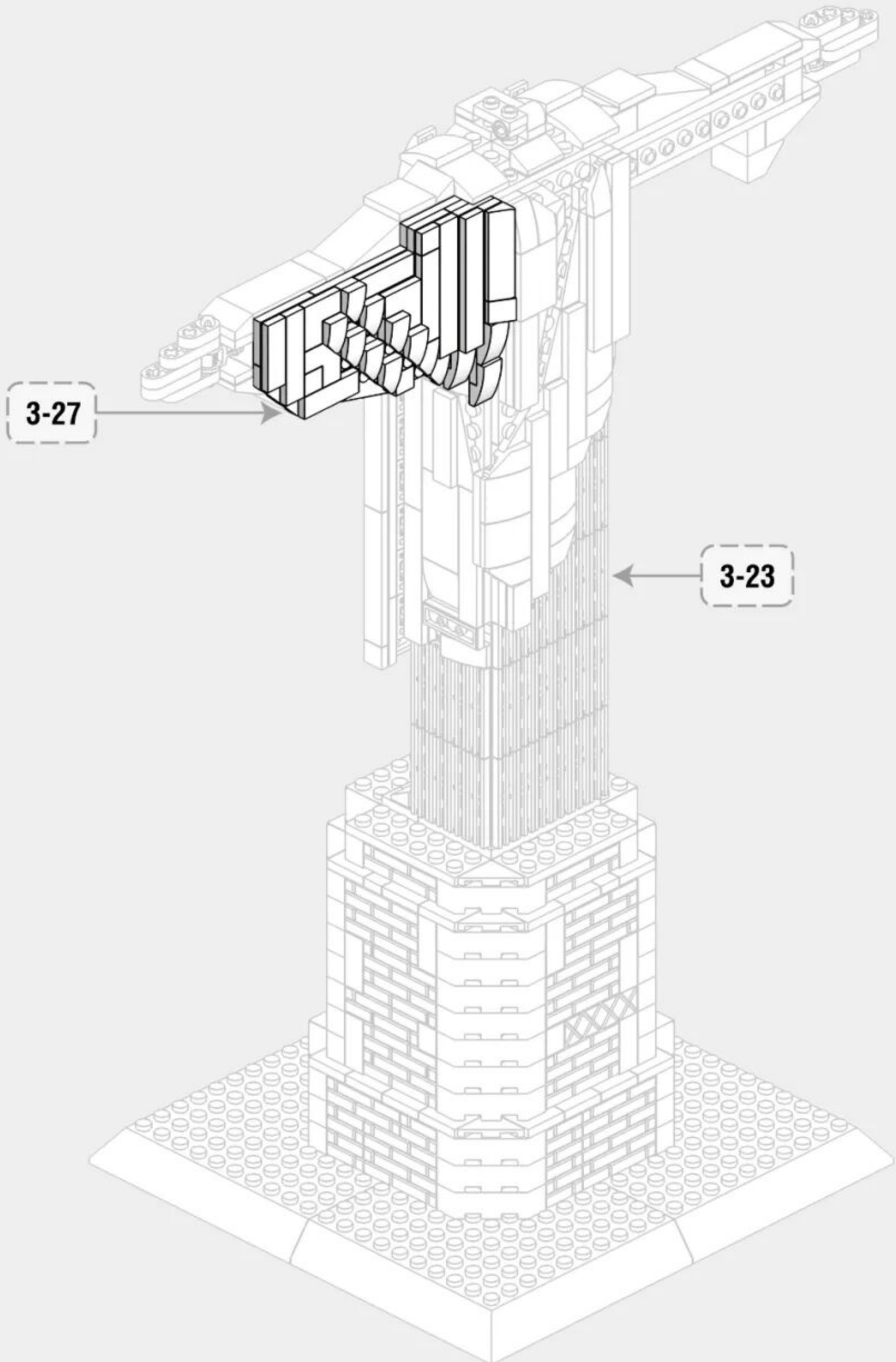



276PCS

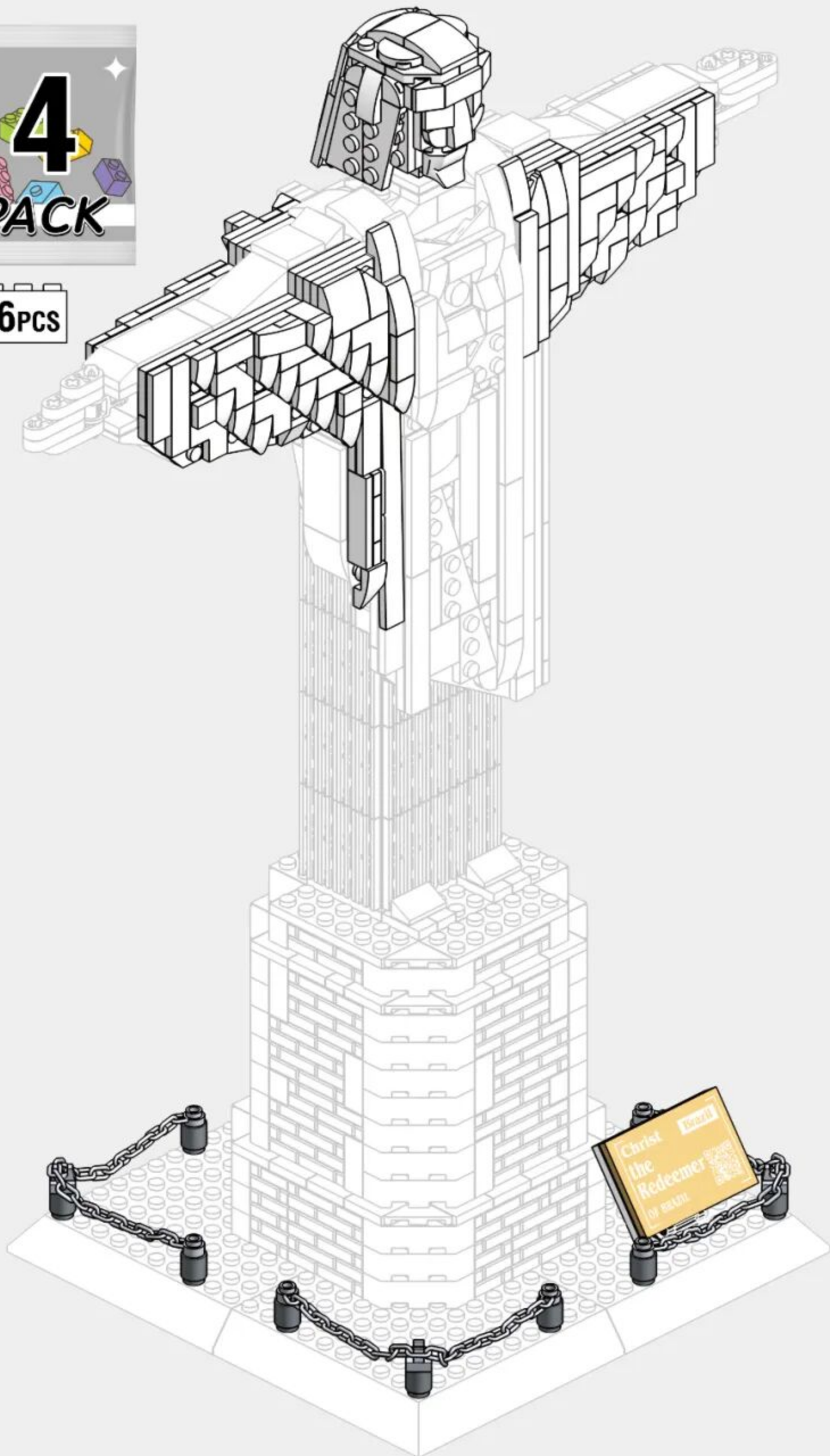

4-1

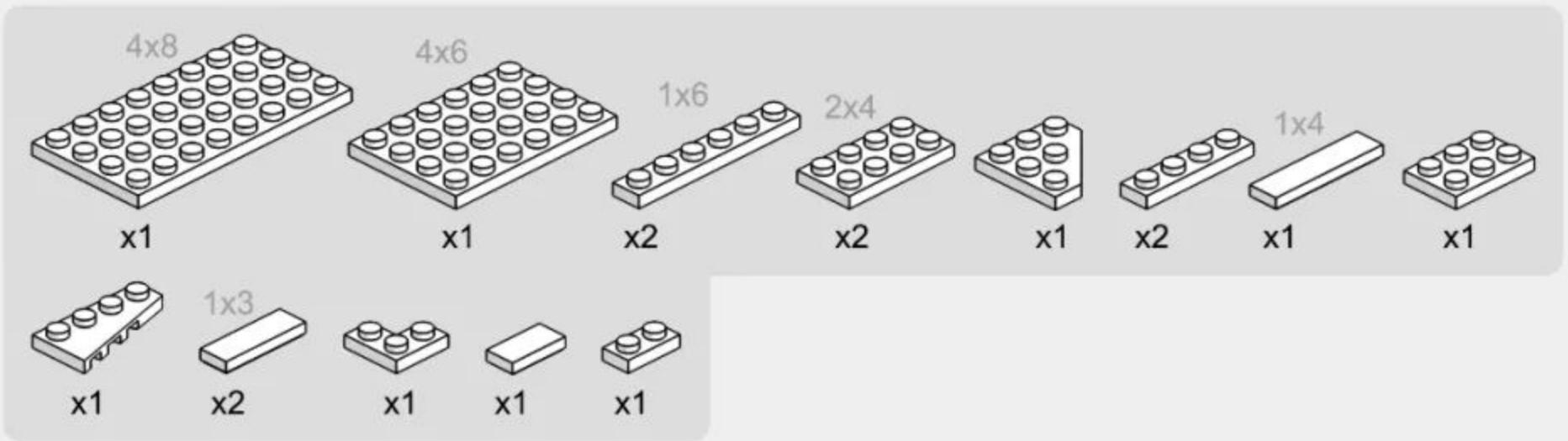

1

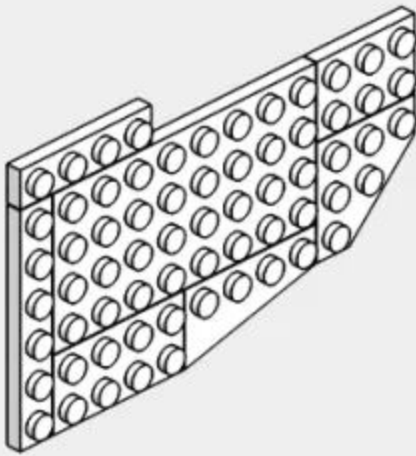

2

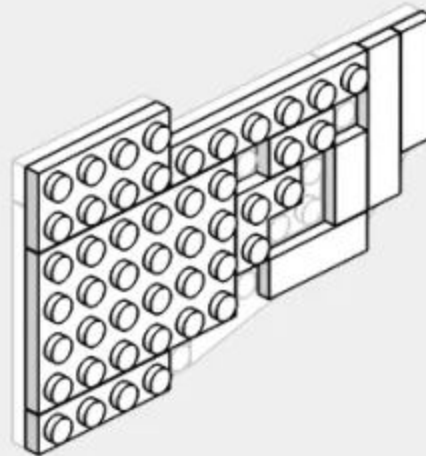

4-2



1

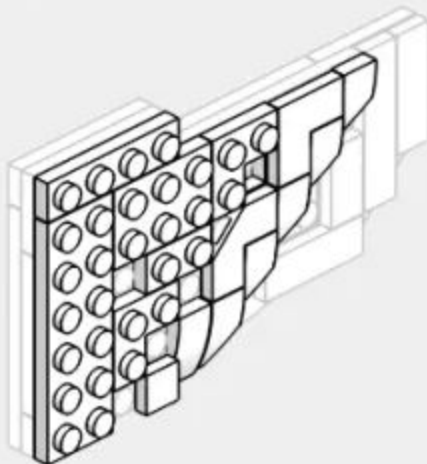

2

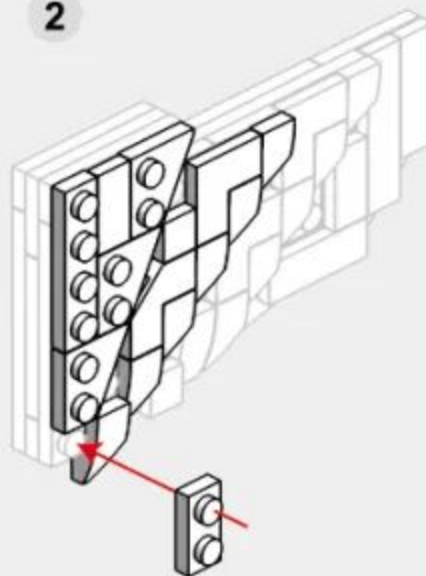

4-3

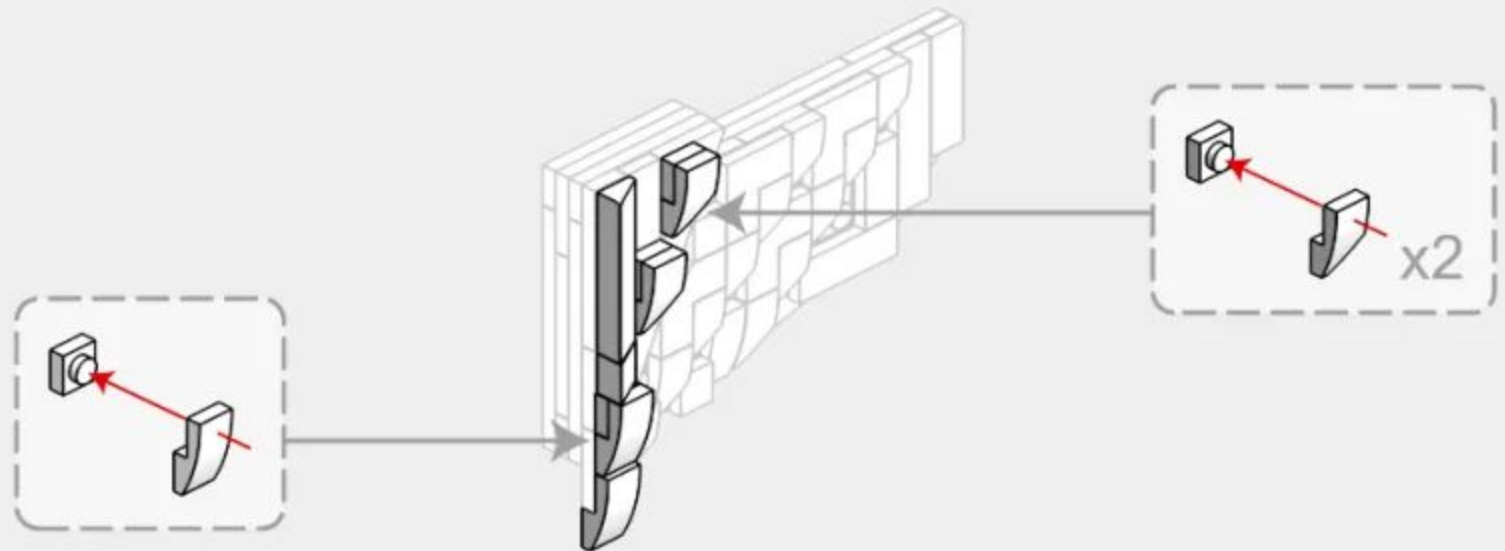
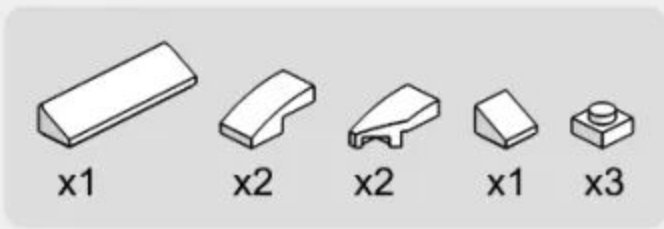

4-4

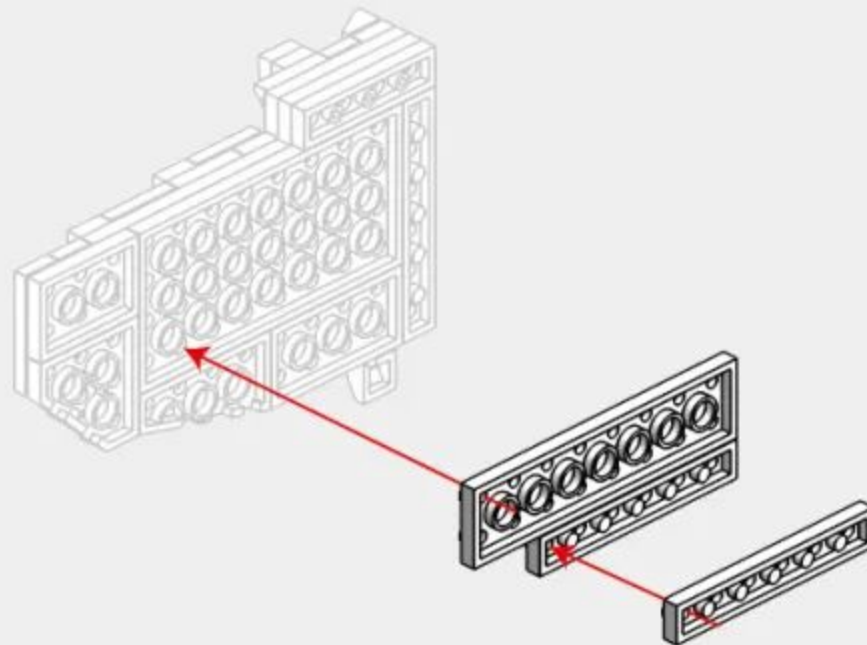
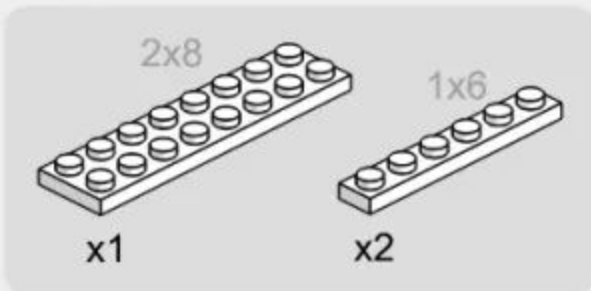

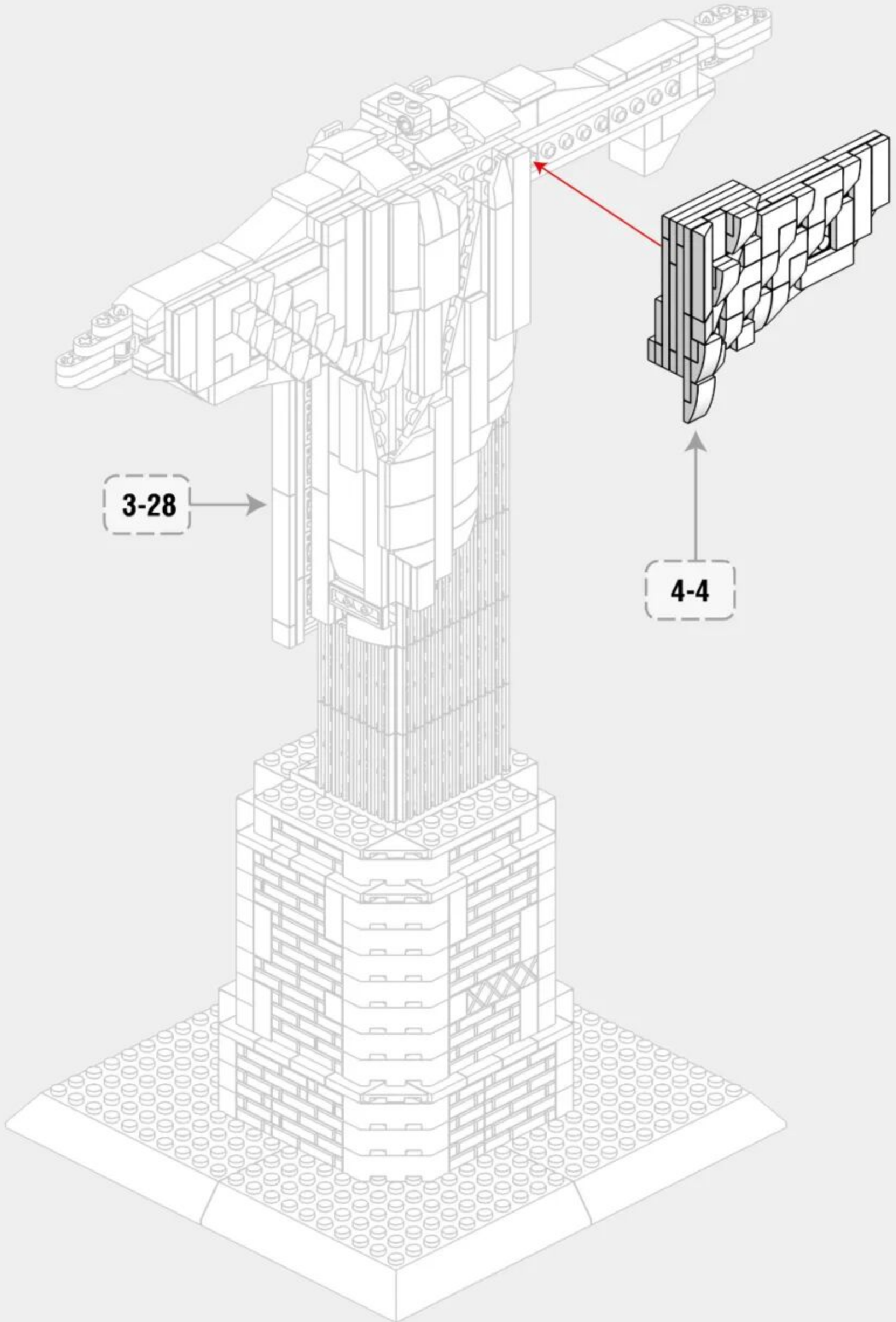

4-8

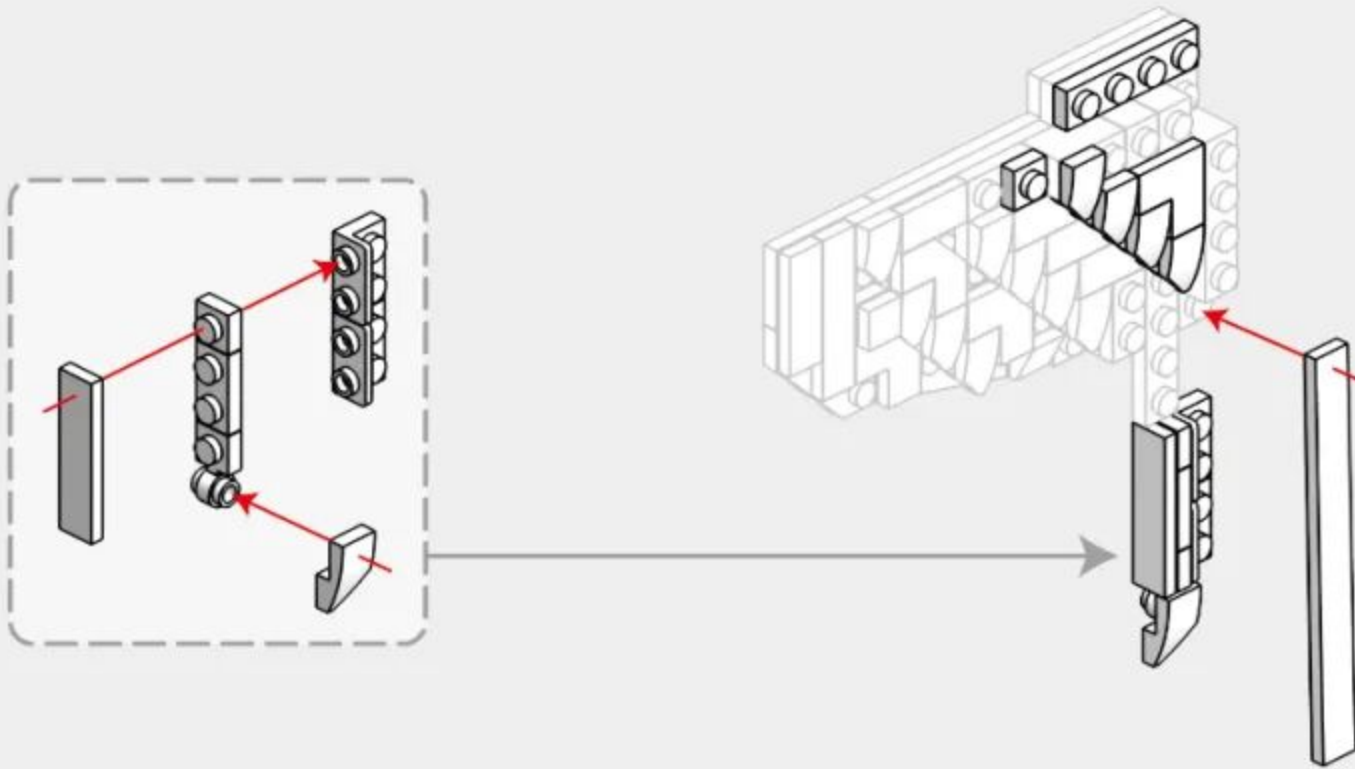
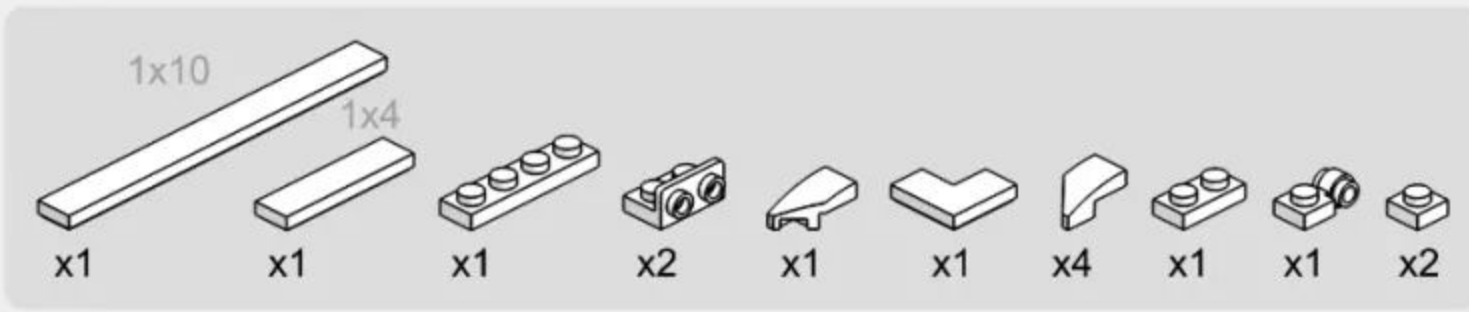

4-9

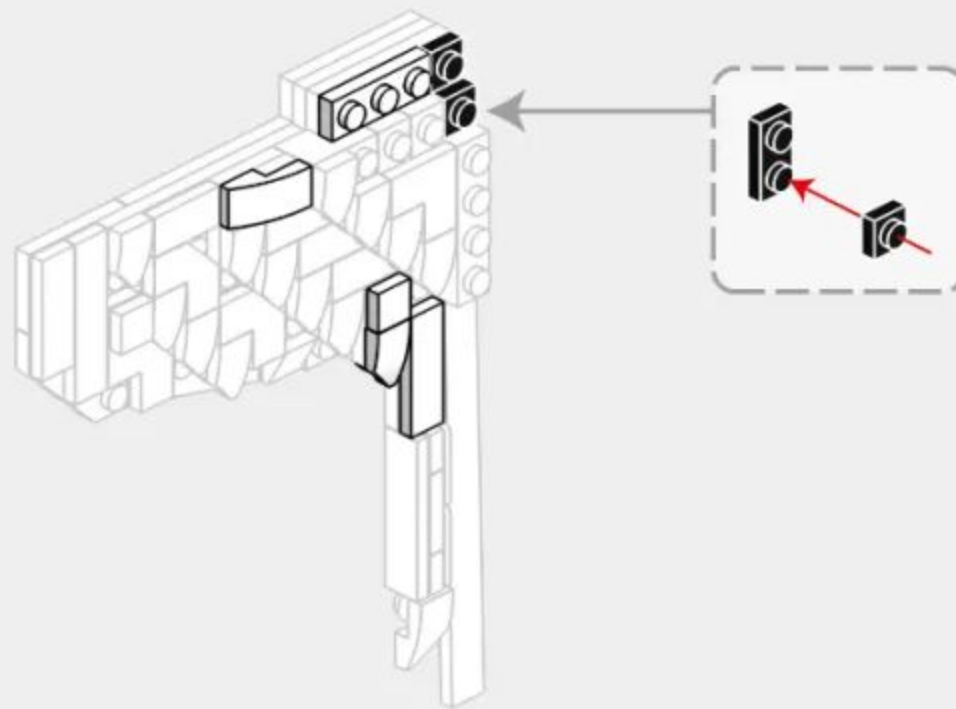
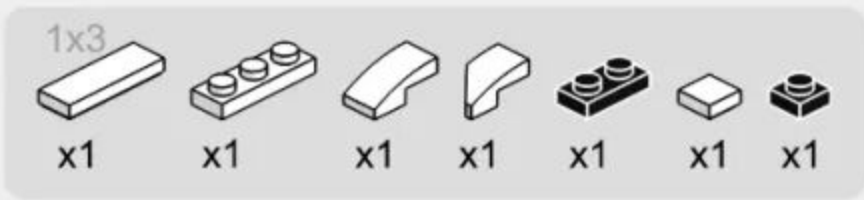

4-10

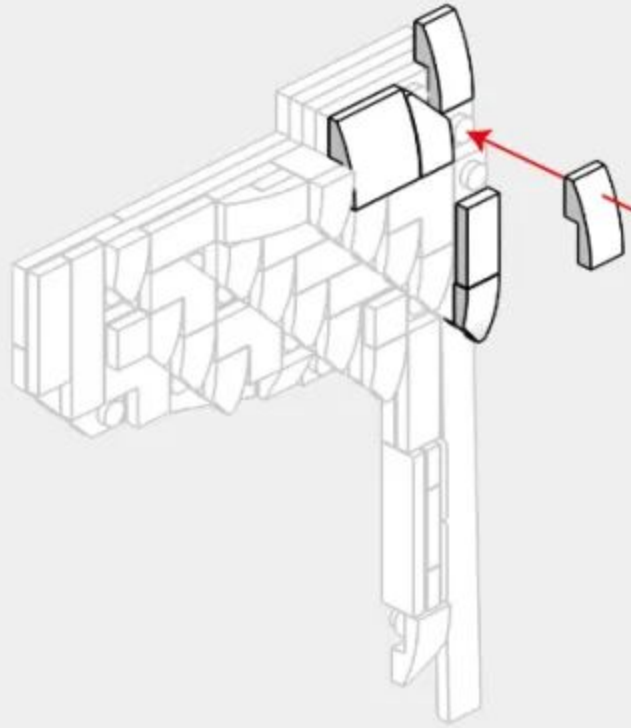
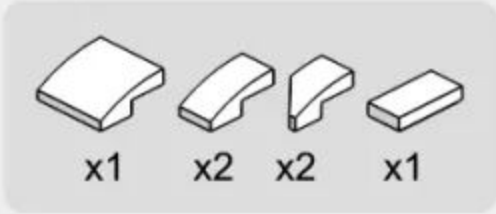

4-11

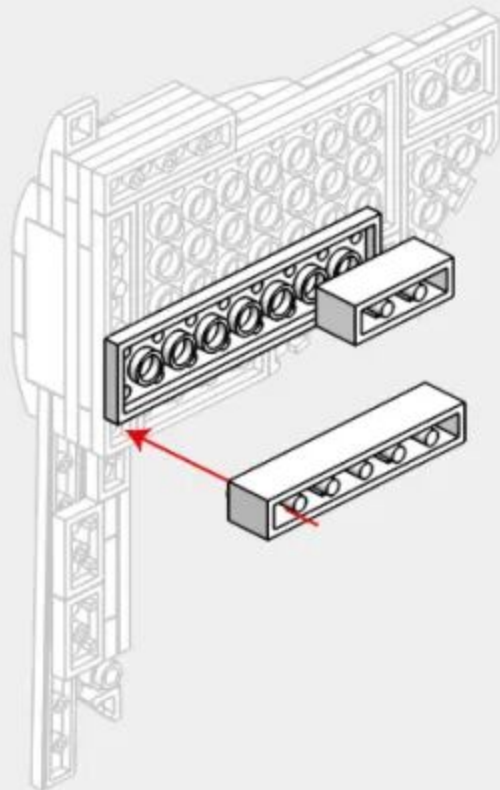
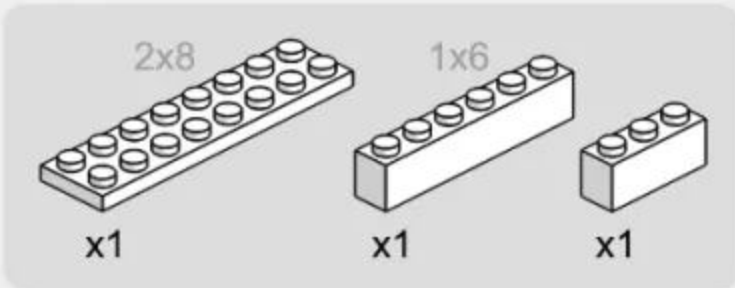

4-12

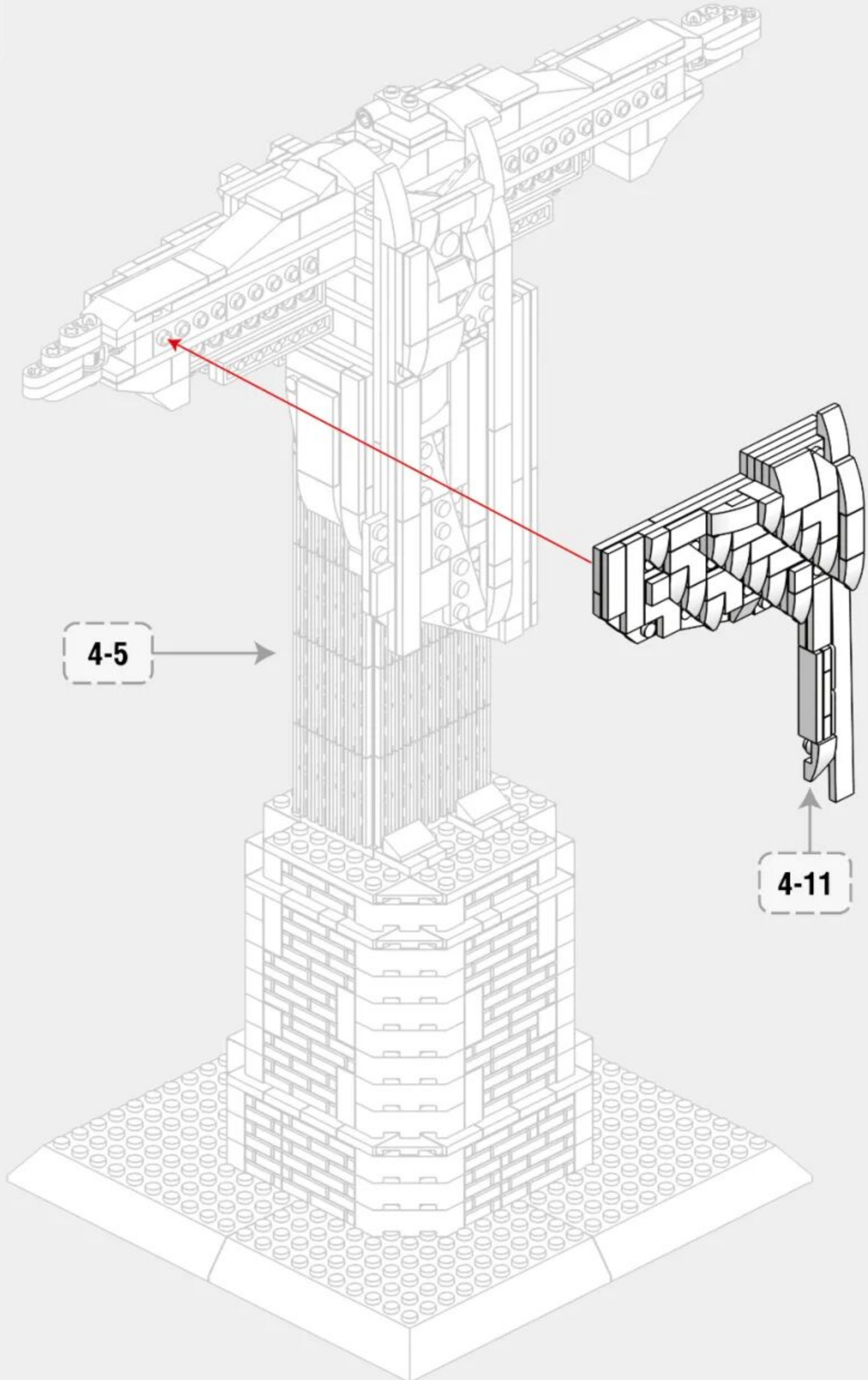

4-15

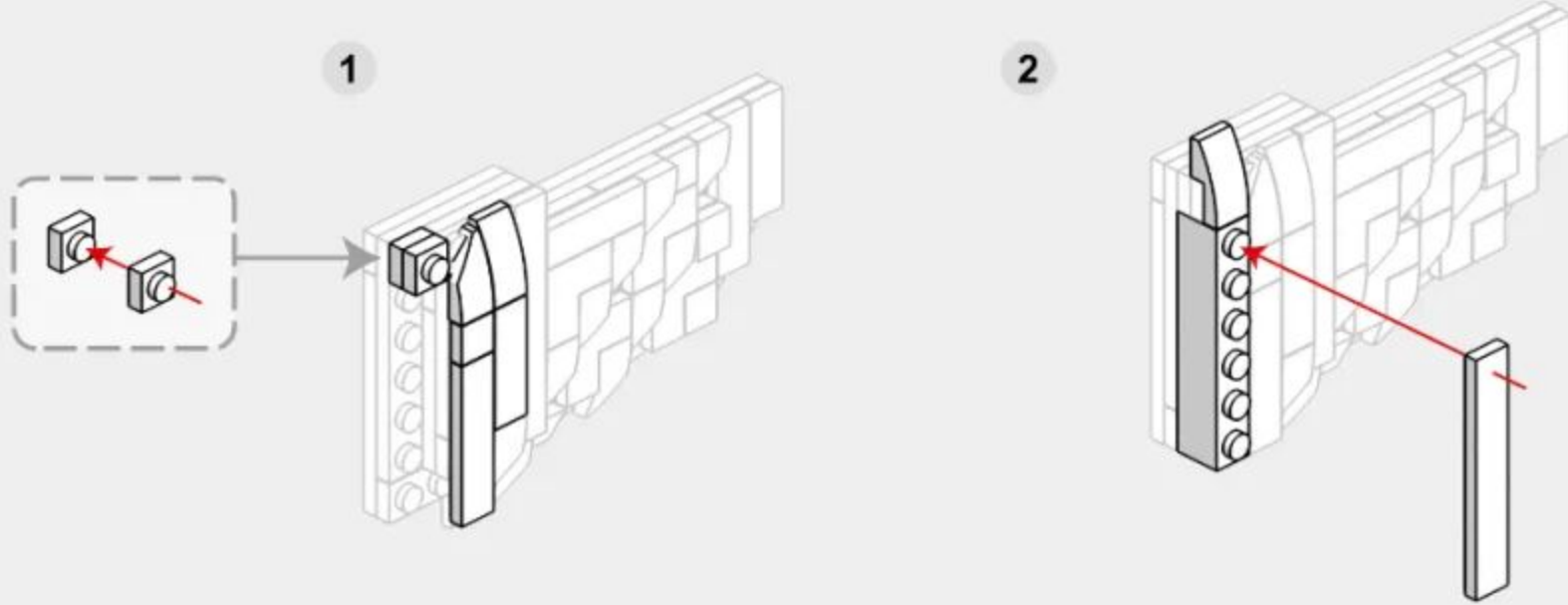
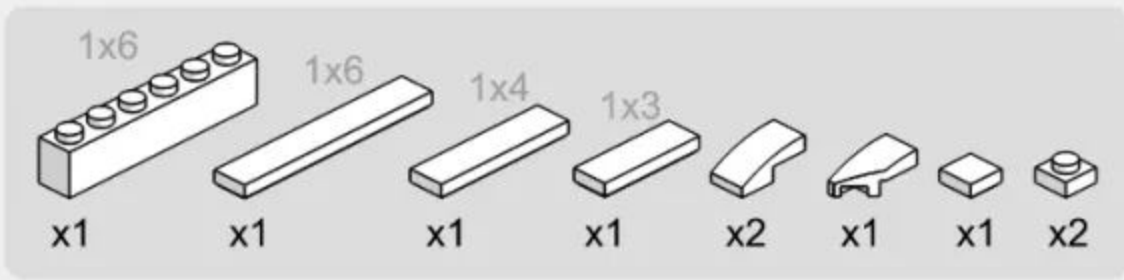

4-16

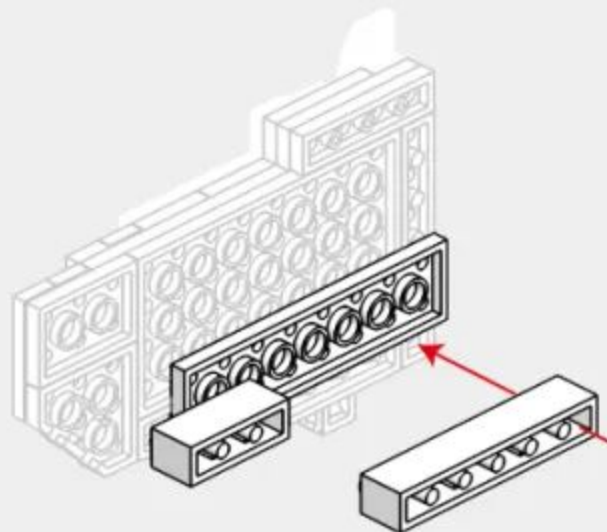
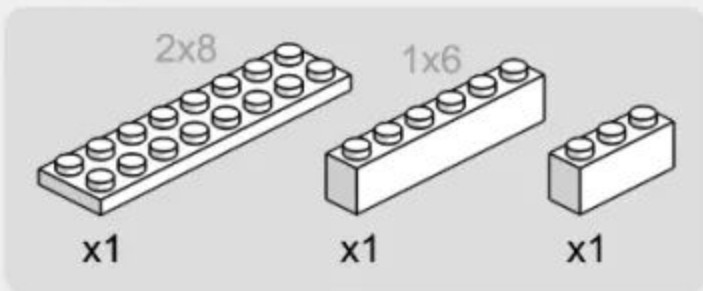

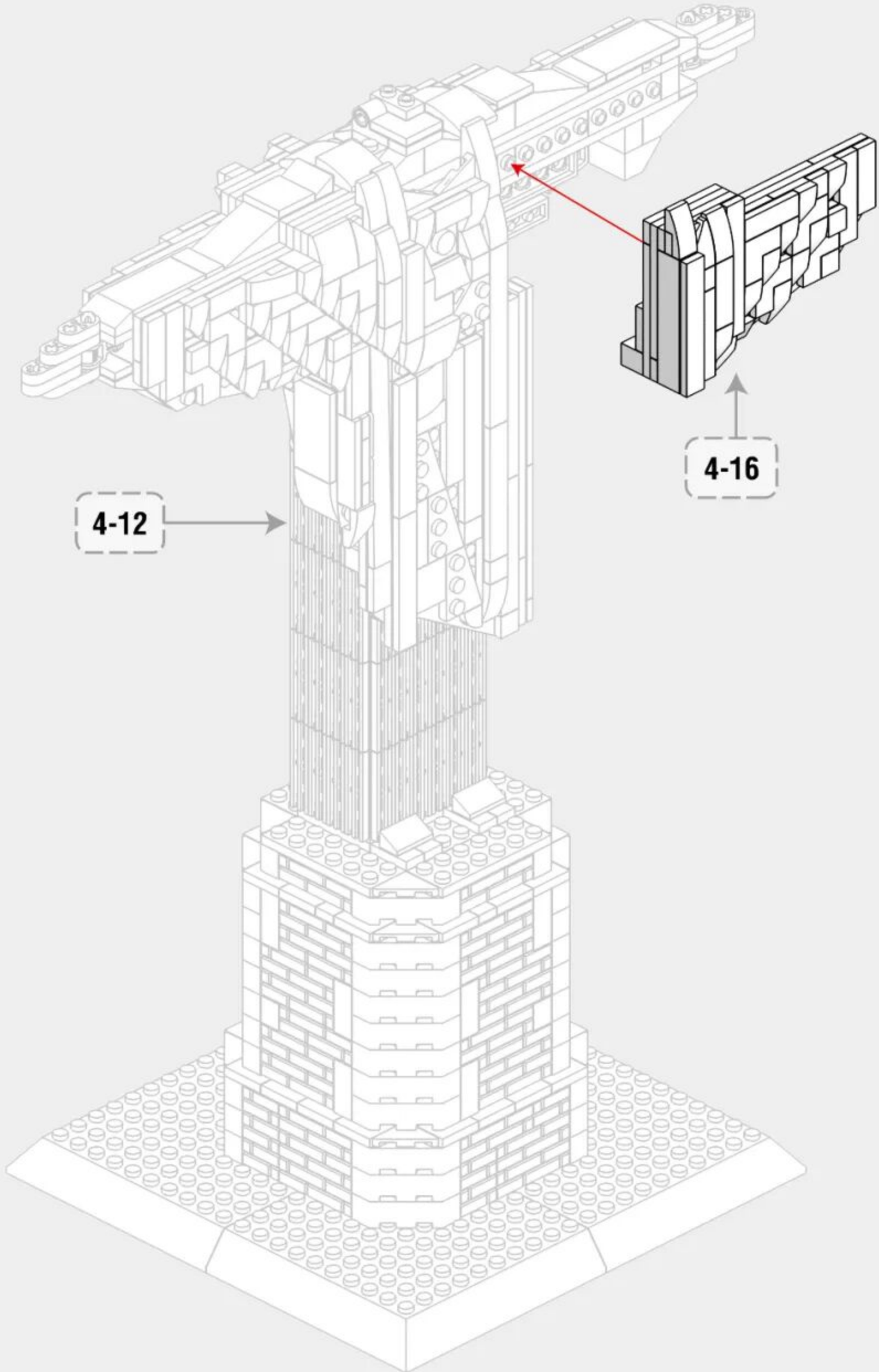

4-18

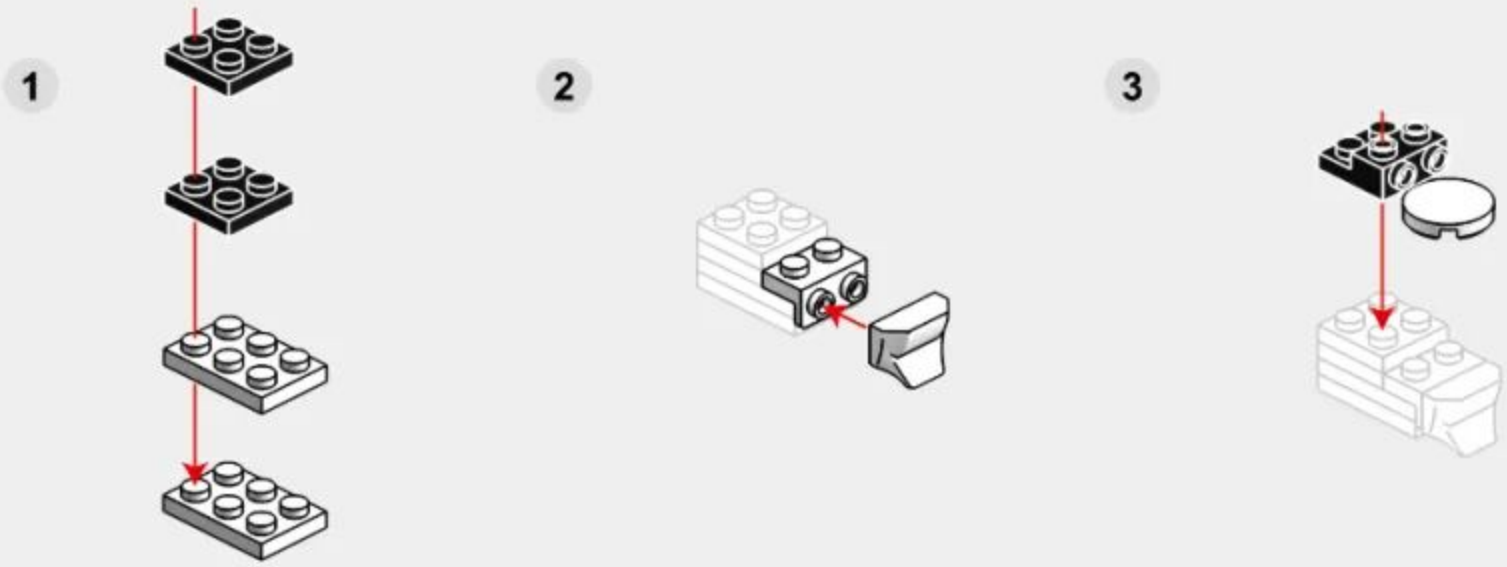
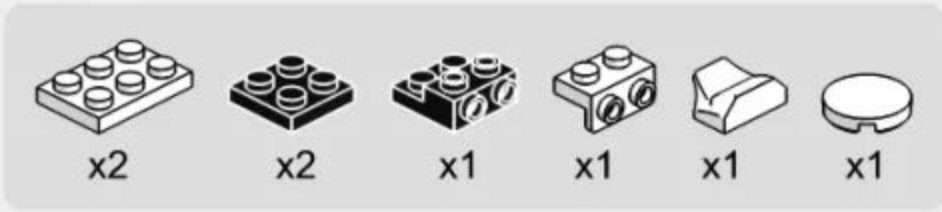

4-19

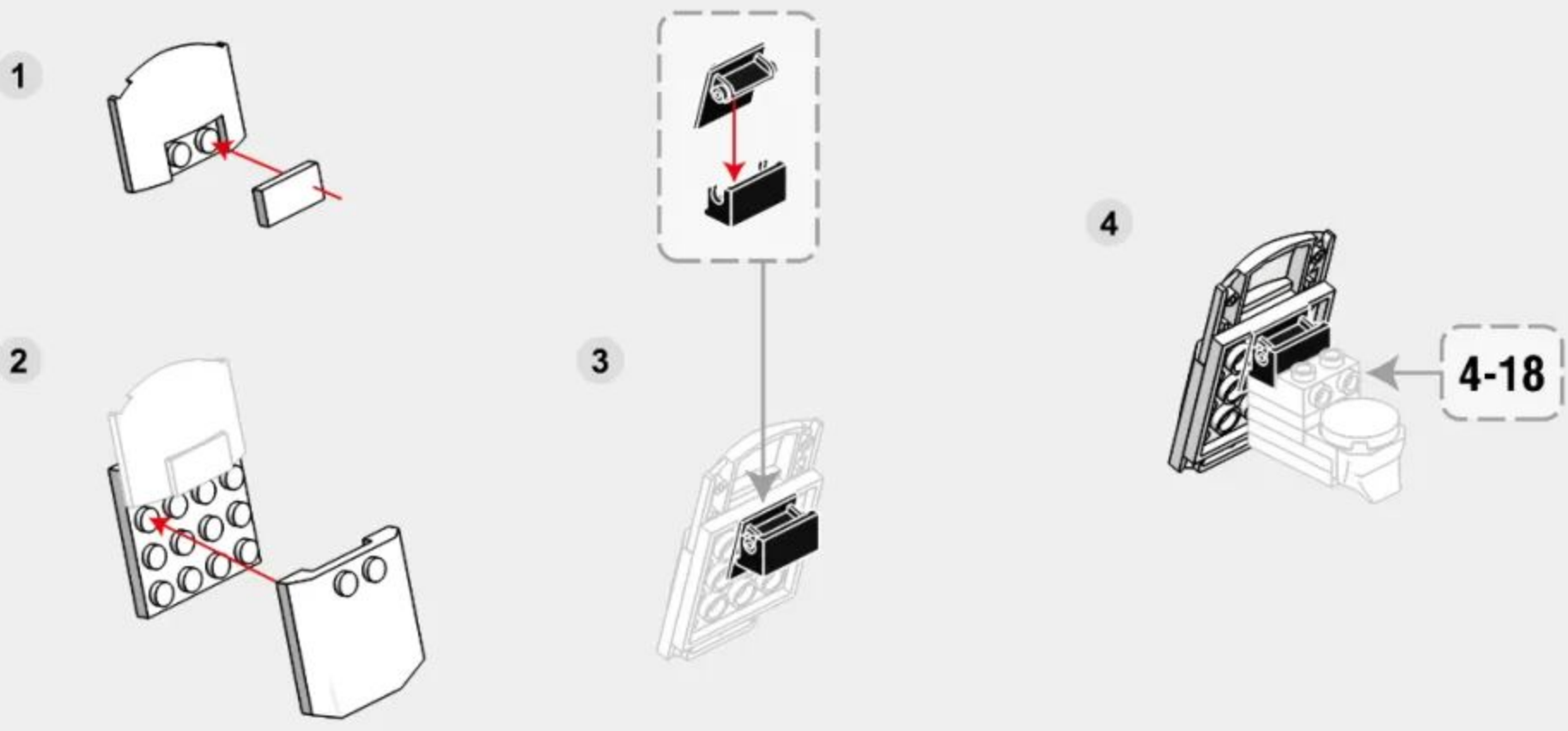
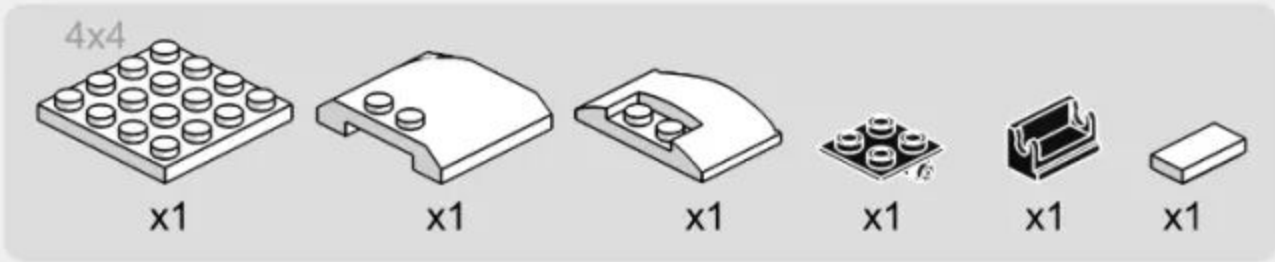

4-20

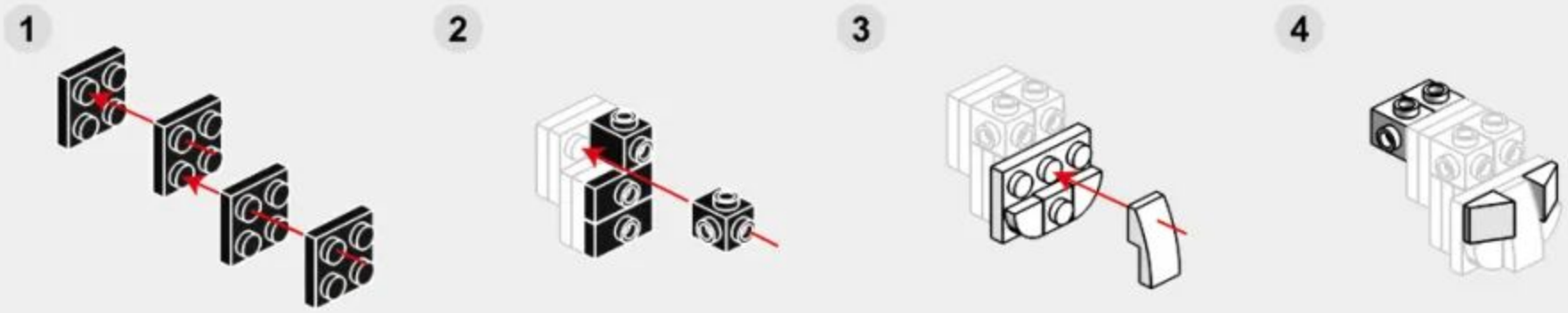

4-21

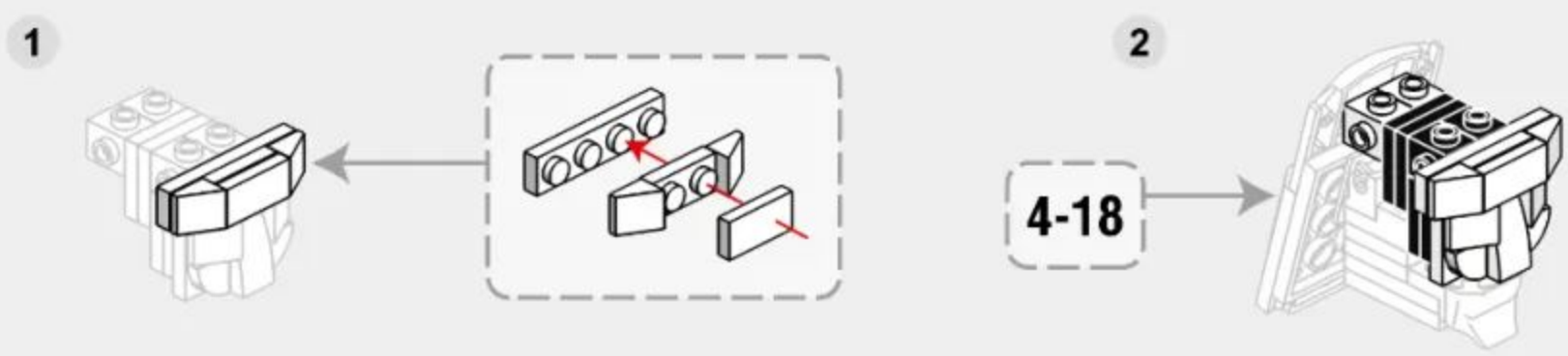
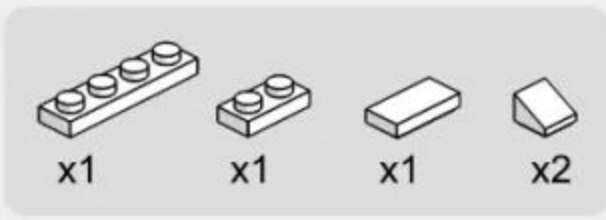

4-22

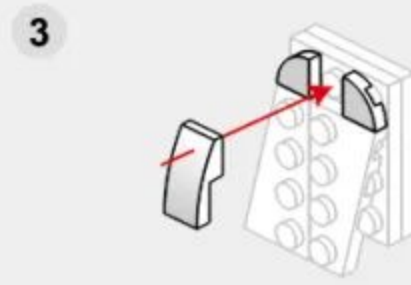
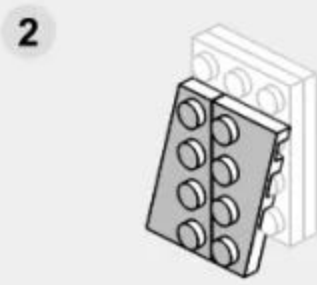
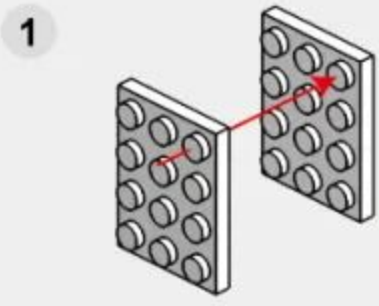
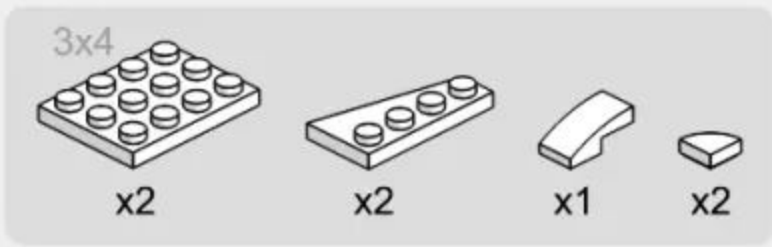

4-23

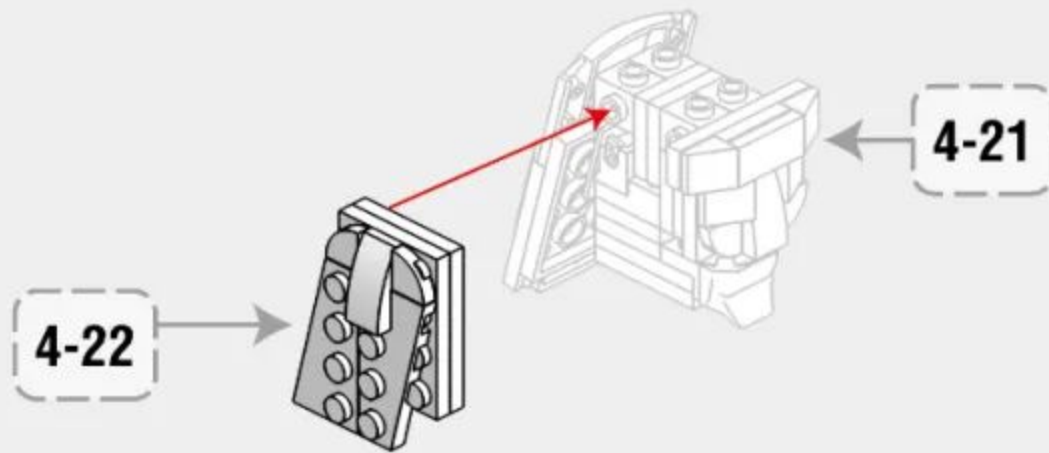

4-24

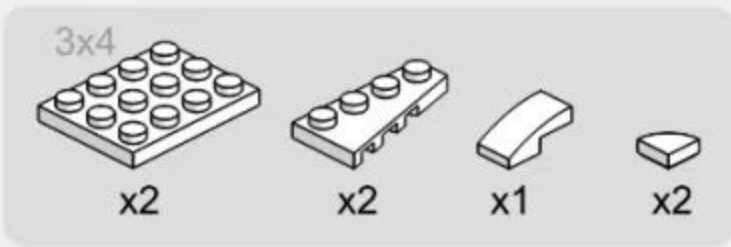

1

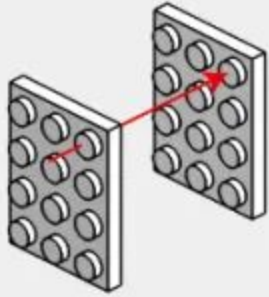

2

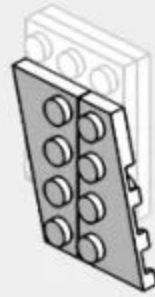

3

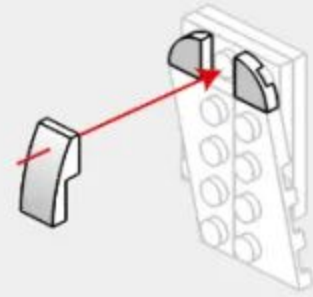

4-25

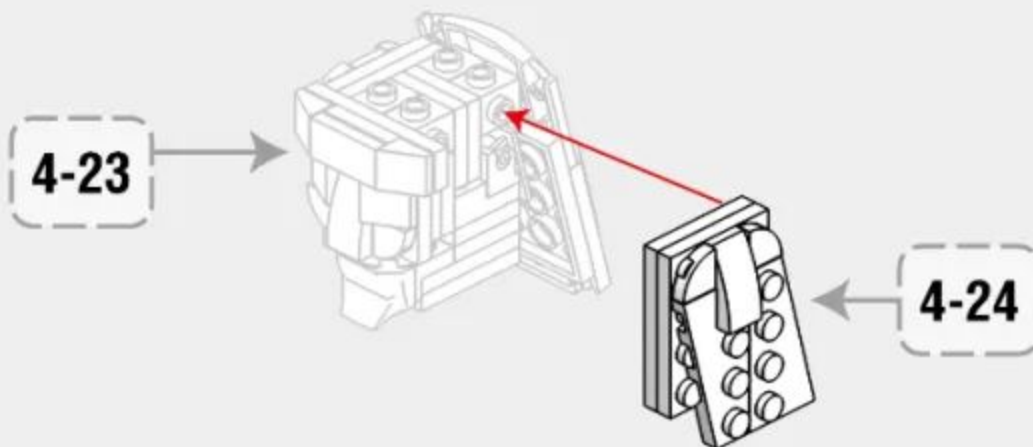

4-26

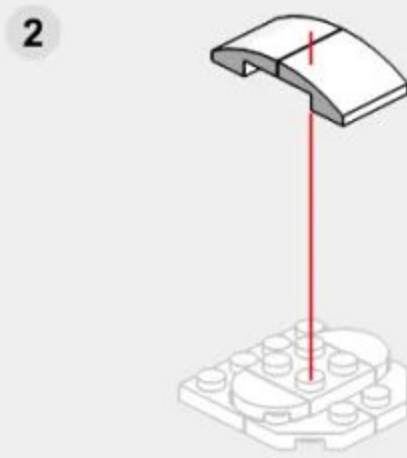
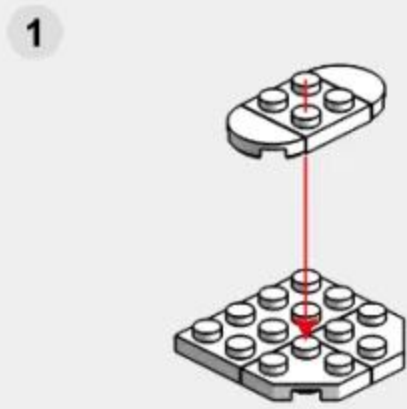
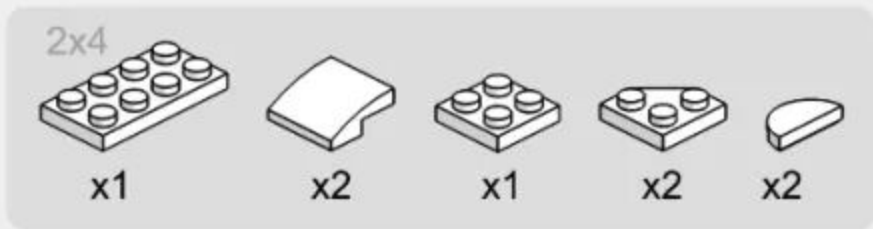

4-27

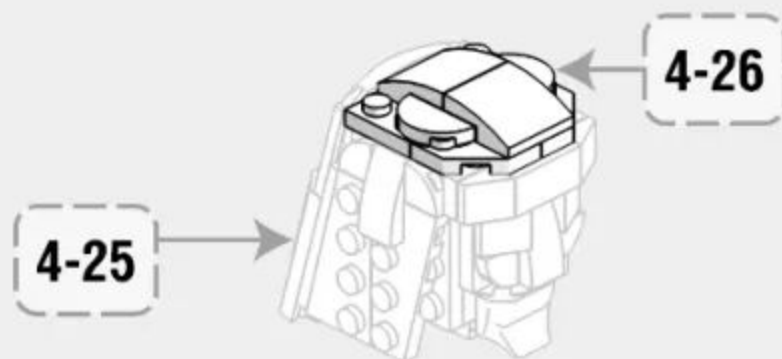

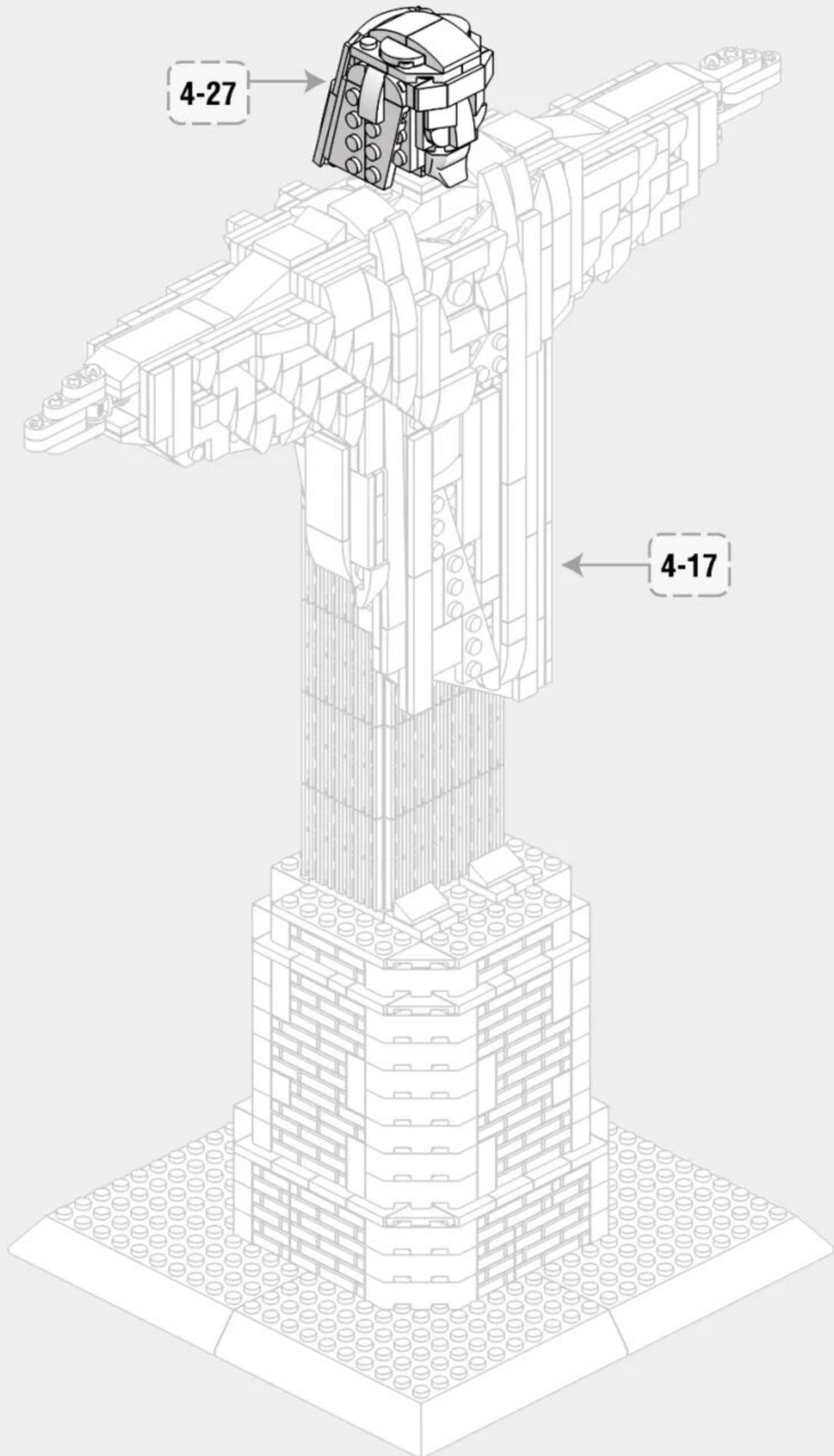

4-29

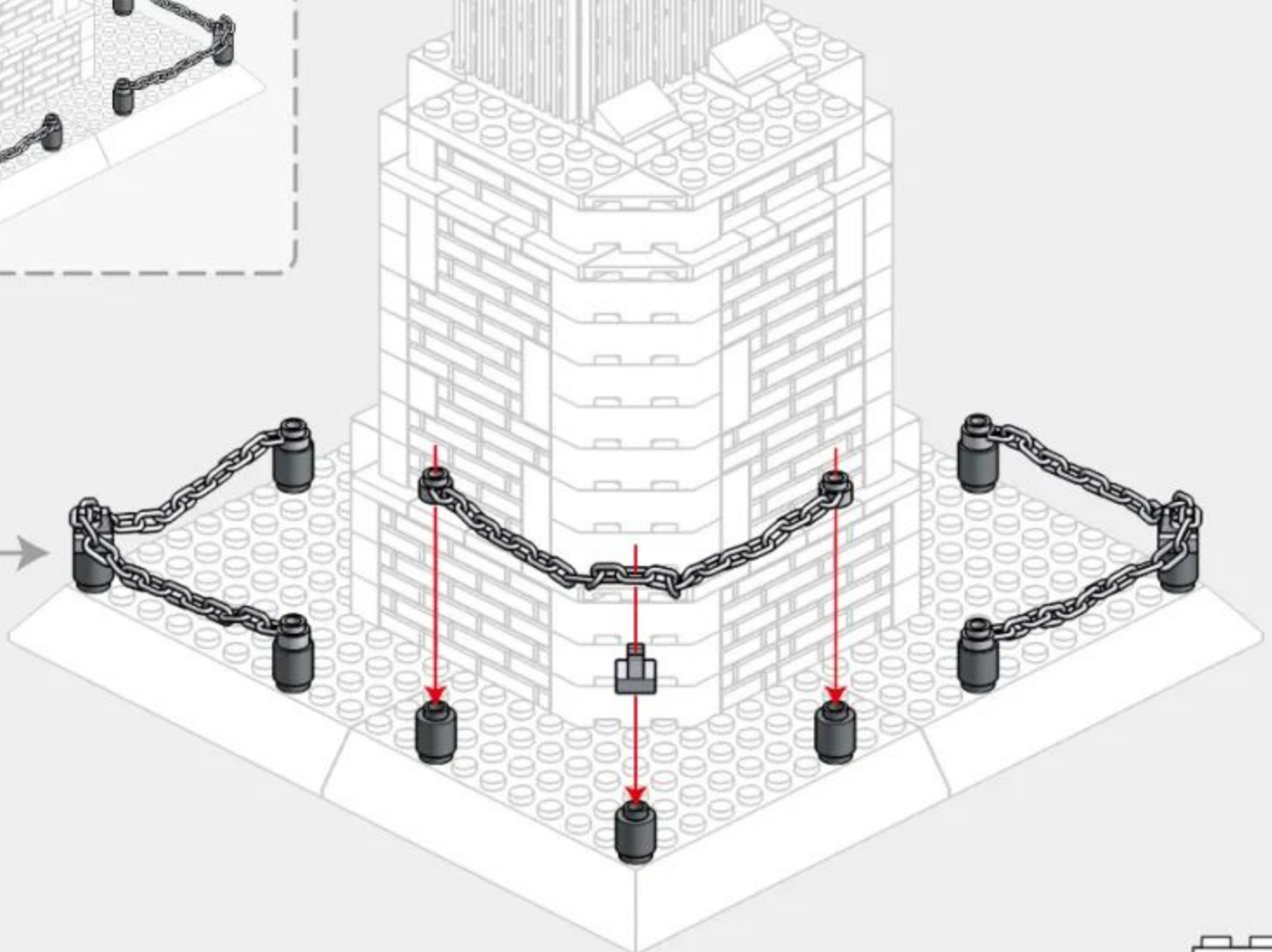
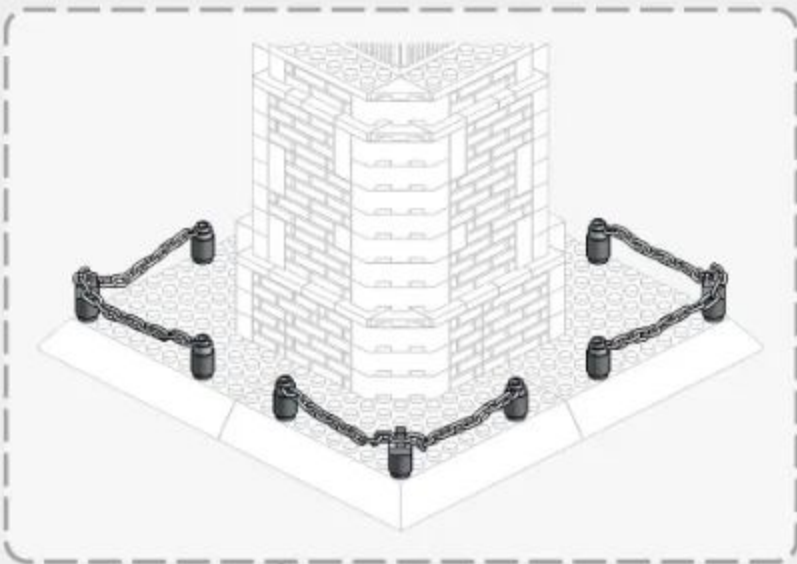
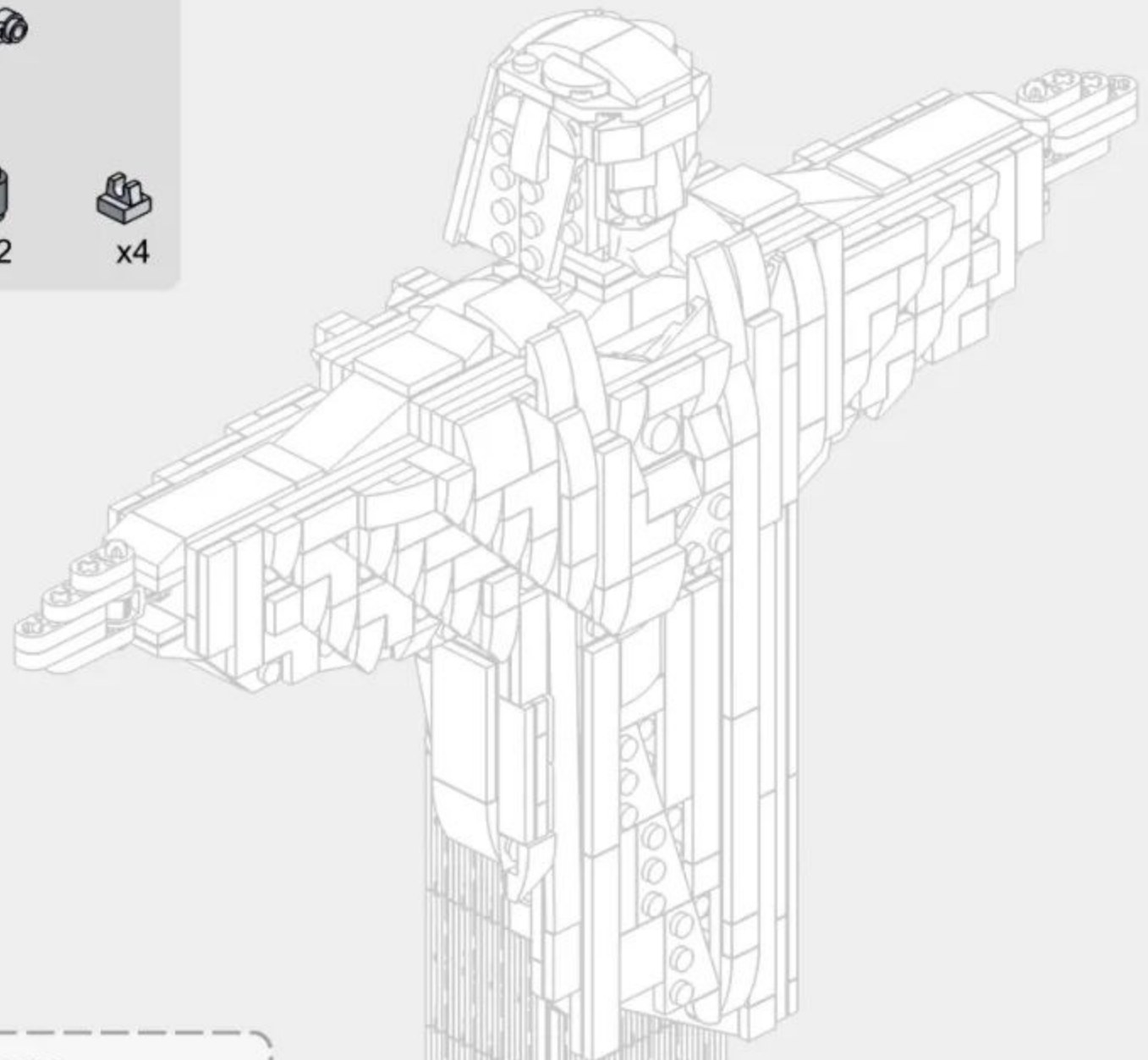

4-30

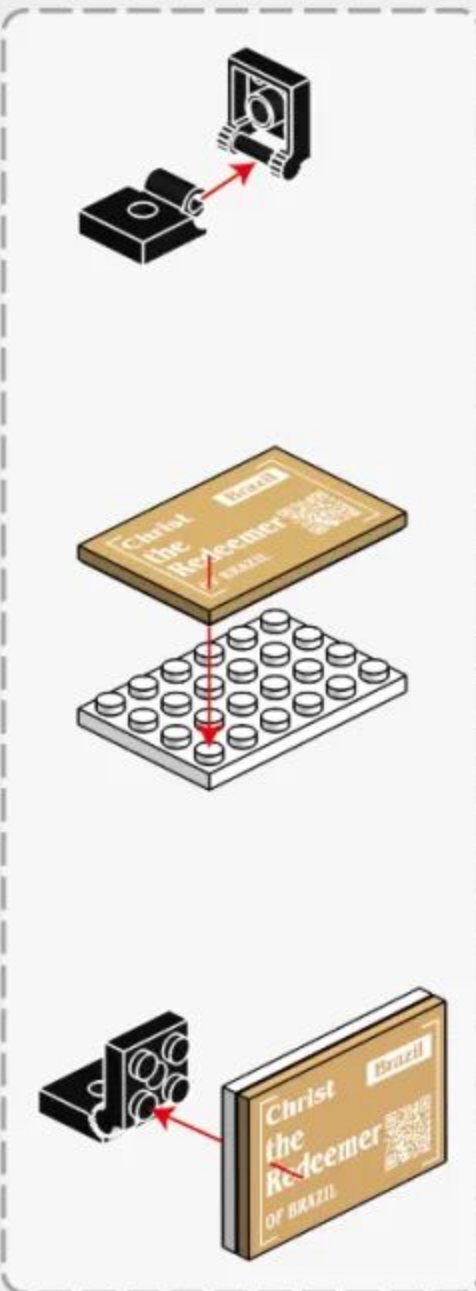
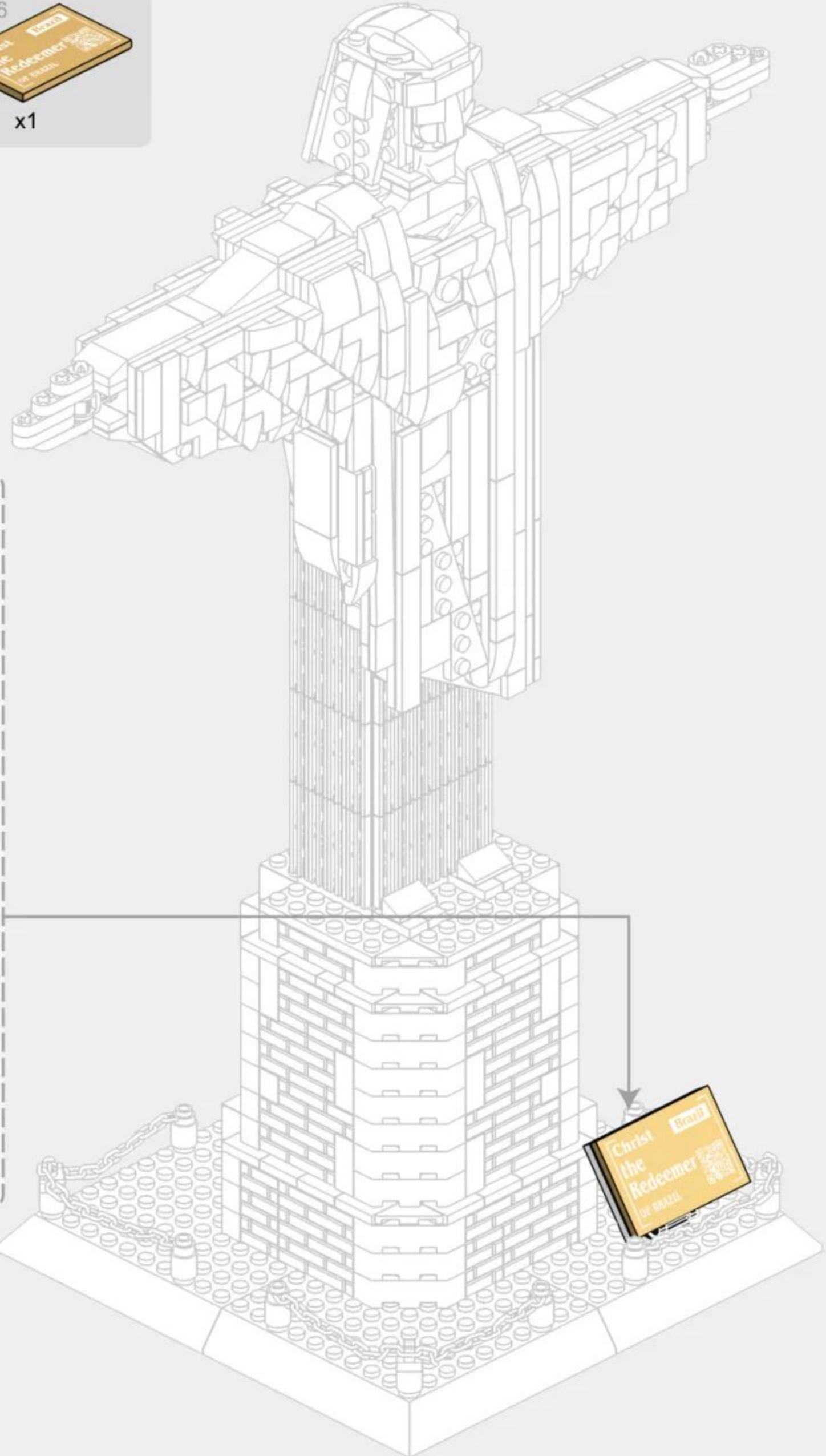
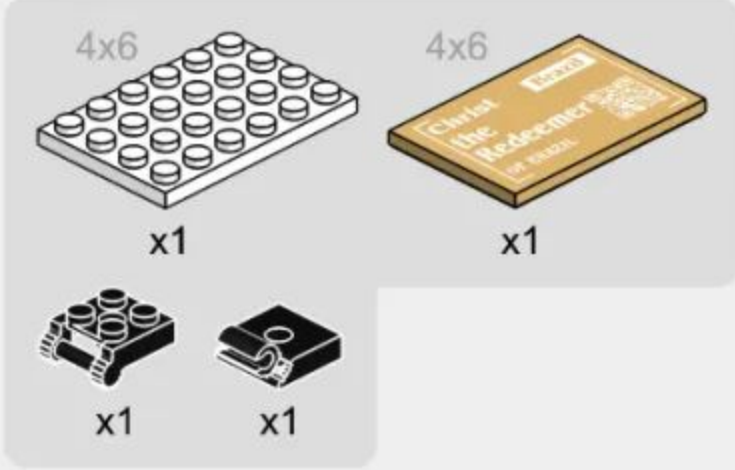

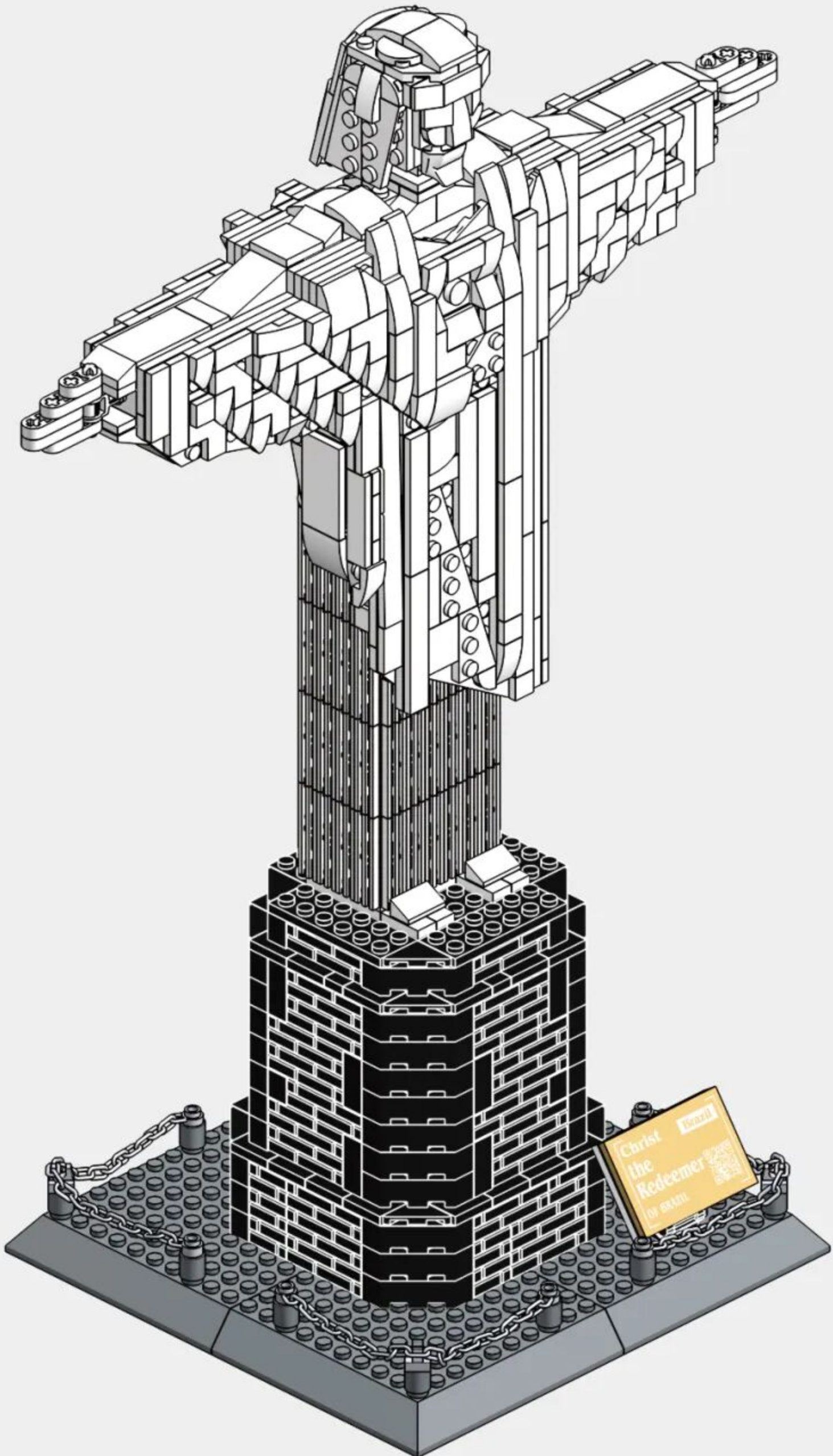

ARCHITECTURE

The World's great architecture

Shaping Skills Imagination & Curiosity Mathematical Self Discovery & Perception Parent-Child Interaction Problem Solving Creativity



6224 英国伦敦白金汉宫
BUCKINGHAM PALACE-LONDON,ENGLAND



5225 意大利罗马斗兽场
COLOSSEUM-ROME,ITALY



5226 日本东京帝国饭店
IMPERIAL HOTEL-TOKYO,JAPAN



6211 德国柏林勃兰登堡门
BRANDENBURG GATE-BERLIN, GERMANY



6222 中国甘肃长城-嘉峪关
JIAYU PASS-GANSU,CHINA



6212 日本京都清水寺仁王门
NOMON GATE OF KIYOMIZU-DERA-KYOTO,JAPAN



6214 中国武汉黄鹤楼
YELLOW CRANE TOWER-WUHAN,CHINA



6215 英国伦敦眼
LONDON EYE-LONDON,ENGLAND



6221 中国北京故宫-太和殿
HALL OF SUPREME HARMONY-BEIJING,CHINA



6213 俄罗斯莫斯科瓦西里大教堂
SAINT BASIL'S CATHEDRAL-MOSCOW,RUSSIA



6220 沙特阿拉伯麦加大清真寺
GREAT MOSQUE OF MECCA,SAUDI ARABIA



6219 美国纽约联合国大厦
UNITED NATIONS HEADQUARTERS-NEW YORK,AMERICA



4214 美国华盛顿白宫
WHITE HOUSE-WASHINGTON D.C.,AMERICA



4212 意大利罗马许愿池
TREVİ FOUNTAIN-ROME,ITALY



4213 法国巴黎卢浮宫
MUSÉE DU LOUVRE-PARIS,FRANCE



4218 新加坡-鱼尾狮
MERLION,SINGAPORE



4210 埃及开罗吉萨金字塔
GREAT PYRAMID OF GIZA-CAIRO,EGYPT



4219 英国伦敦双子塔桥
TOWER BRIDGE-LONDON,ENGLAND



4216 美国华盛顿林肯纪念堂
LINCOLN MEMORIAL-WASHINGTON D.C.,AMERICA



4217 新加坡-金沙酒店
MARINA BAY SANDS,SINGAPORE



7210 中国上海世博会中国馆
CHINA PAVILION AT EXPO-SHANGHAI, CHINA



4221 加拿大渥太华国会山庄
PARLIAMENT BUILDINGS-OTTAWA, CANADA



4211 英国伦敦伊丽莎白塔
ELIZABETH TOWER-ENGLAND



4220 美国纽约熨斗大厦
FLATIRON BUILDING-NEW YORK, AMERICA



5227 美国纽约自由女神像
STATUE OF LIBERTY-NEW YORK, AMERICA



4215 加拿大多伦多电视塔
THE CN TOWER-CANADA



4222 阿联酋迪拜哈利法塔
THE BURJ KHALIFA TOWER-DUBAI, UAE



5224 中国上海东方明珠广播电视塔
ORIENTAL PEARL TOWER-SHANGHAI, CHINA



5212 美国纽约帝国大厦
EMPIRE STATE BUILDING-NEW YORK, AMERICA



5213 马来西亚吉隆坡石油双塔
PETRONAS TWIN TOWERS-KUALA LUMPUR, MALAYSIA



5214 意大利托斯卡纳比萨斜塔
LEANING TOWER OF PISA-TUSCANY, ITALY



5216 英国伦敦伊丽莎白塔
ELIZABETH TOWER-LONDON, ENGLAND



5219 俄罗斯莫斯科克里姆林宫钟楼
SPASSKAYA TOWER-MOSCOW, RUSSIA



5220 阿联酋迪拜卓美亚帆船酒店
BURJ AL ARAB HOTEL-DUBAI, UAE



5217 法国巴黎埃菲尔铁塔
EIFFEL TOWER-PARIS, FRANCE



5221 中国台北101大楼
TAIPEI 101-TAIPEI, CHINA



6223 中国武汉长江大桥
WUHAN YANGTZE RIVER BRIDGE



5210 法国巴黎圣母院大教堂
CATHÉDRALE NOTRE DAME DE PARIS-PARIS, FRANCE



5223 法国巴黎凯旋门
ARC DE TRIOMPHE-PARIS, FRANCE



5211 印度阿格拉泰姬陵
TAJ MAHAL-AGRA, INDIA



5215 英国伦敦双子塔桥
TOWER BRIDGE-LONDON,ENGLAND



5222 中国北京天坛祈年殿
HALL OF PRAYER FOR GOOD HARVESTS-BEIJING,CHINA



6210 美国旧金山金门大桥
GOLDEN GATE BRIDGE-SAN FRANCISCO,AMERICA



6216 中国北京万里长城（八达岭）
THE GREAT WALL-BEIJING,CHINA



5218 中国北京天安门
TIAN'ANMEN TOWER-BEIJING,CHINA



6217 中国西藏布达拉宫
POTALA PALACE-TIBET,CHINA



6218 芬兰罗瓦涅米圣诞老人办公室
SANTA CLAUS OFFICE-ROVANIEMI,FINLAND



6225 墨西哥库库尔坎玛雅金字塔
EL CASTILLO-KUKULKAN,MEXICO



6226 德国巴伐利亚新天鹅堡
SCHLOSS NEUSCHWANSTEIN-BAYERN, DEUTSCHLAND



5228 美国芝加哥威利斯大厦
WILLIS TOWER-CHICAGO, AMERICA



5229 土耳其伊斯坦布尔其少女塔
MAIDEN TOWER-ISTANBUL,TURKEY



5230 中国湖南长沙爱晚亭
AIWAN TING PAVILION-HUNAN,CHINA



5231 巴西里约热内卢救世基督像
CRISTO REDENTOR-RIO DE JANEIRO, BRASIL



5232 美国宾夕法尼亚州流水别墅
FALLINGWATER-PENNSYLVANIA, AMERICA





CHRIST THE REDEEMER

COUNTRY: Brazil
CITY: Rio de Janeiro



Ver.5231210907



微信扫一扫
补件更简单