

# ZUIWENG PAVILION

中国安徽醉翁亭

Anhui, China

The world's great architecture



亭翁醉



6+ / 5236 / 917PCS  
Suitable Age / Product Number / Part Total



# Architecture

It will be a city...

这将构成一座城市...

# ABOUT THE PRODUCT

关于产品



## ARCHITECTURE

WANGE The world's great architect since 1991

# Zuiweng Pavilion



Next to Langya Ancient Road, Nanqiao District, Chuzhou City



# Zuiweng Pavilion



Geography and culture

地理·文化



The Drunkard Pavilion is one of the four famous pavilions and one of the representatives of ancient Chinese traditional architecture.



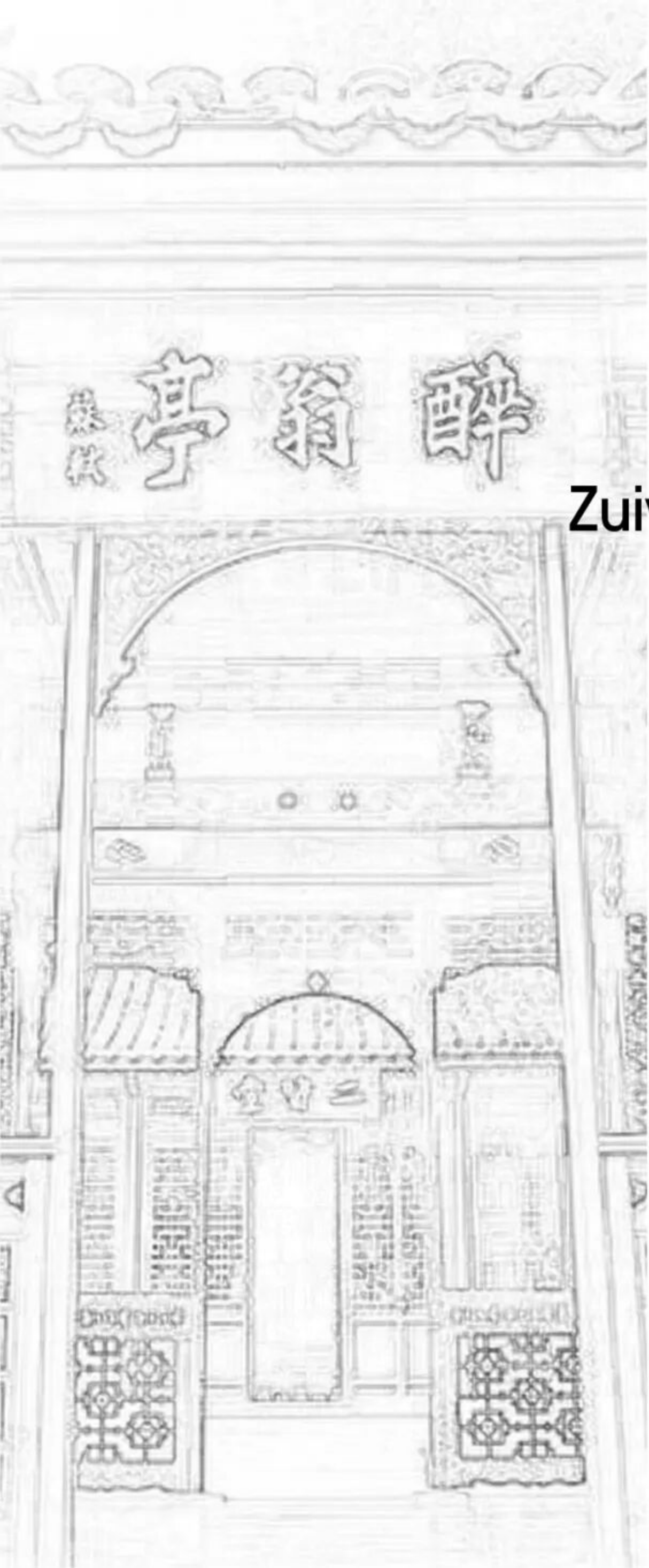

中国安徽醉翁亭

# Zuiweng Pavilion ■

China

The contents of this chapter refer to the Wikipedia website.

本章内容参考维基百科网站，更多资讯可自行查阅。

The world's great architecture

# Buildings and layout

■ 建筑物和布局



**醉翁亭**，位于安徽省滁州市西南琅琊山麓，始建于北宋庆历七年（1047年），由唐宋八大家之一欧阳修命名。醉翁亭总面积约1000平方米，亭园内有九院七亭：醉翁亭、宝宋斋、冯公祠、古梅亭、影香亭、意在亭、怡亭、览余台，风格各异，互不雷同，人称“醉翁九景”。醉翁亭前有“让泉”。醉翁亭整个布局严谨小巧，曲折幽深，富有诗情画意。亭中新塑欧阳修立像。亭旁有一巨石，上刻圆底篆体“醉翁亭”三字。醉翁亭一带的建筑，布局紧凑别致，具有江南园林特色。

Zuiweng Pavilion, located at the foot of Langya Mountain in the southwest of Chuzhou City, Anhui Province, was built in the seventh year of Qingli in the Northern Song Dynasty (1047) and was named by Ouyang Xiu, one of the Eight Great Masters of the Tang and Song Dynasties. The total area of the Drunkard Pavilion is about 1,000 square meters. There are nine courtyards and seven pavilions in the pavilion: Drunkard Pavilion, Baosongzhai, Fenggong Temple, Gumei Pavilion, Yingxiang Pavilion, Yizai Pavilion, Yiting Pavilion, and Lanyu Terrace. Different and different from each other, they are called "Nine Scenes of Drunkards". There is a "Rangquan" in front of the Drunkard Pavilion.



## Construction

醉翁亭总面积约1000平方米，醉翁亭为中国传统的歇山式建筑，吻兽伏脊，亭角夸张地飞起，如鸟展翅。亭内可容十多人，南北框门设有格花和浮雕花卉，亭内有晚清时制作的八幅“八仙过海”浮雕。亭中新塑欧阳修立像。沿亭四周有木栏围护，以供观赏山景。亭东的石壁前藤萝低垂，山花掩映，壁上有四处摩崖石刻，皆为记载醉翁亭的兴衰和对该亭的咏歌感叹，其一为南宋人篆书“醉翁亭”三个大字。

The total area of the Drunkard Pavilion is about 1,000 square meters. The Drunkard Pavilion is a traditional Chinese Xieshan-style building. The pavilion can accommodate more than ten people. There are lattice flowers and relief flowers on the north and south frame doors. There are eight relief sculptures of "Eight Immortals Crossing the Sea" made in the late Qing Dynasty in the pavilion. The new statue of Ouyang Xiu in the pavilion.



## History

醉翁亭位于当时的淮南滁州。欧阳修是北宋诗文革新运动的领袖。范仲淹的“庆历新政”失败后，欧阳修受牵连。欧阳修被以莫须有的“张甥案”贬知滁州。欧公居滁，是政治上的挫折，但他能坦然面对，怡然乐观，为政之余，陶醉于“环滁皆山”的景色，常偕僚属留连于琅琊山中，与州民同乐而成为历史佳话。山僧智仙敬重仰慕欧公的学术文章和道德人品，特于山中建亭为他的游山助兴。欧公以“醉翁”作为亭名，并由此创作出了《醉翁亭记》。

The Drunkard Pavilion is located in Chuzhou, Huainan at that time. Ouyang Xiu was the leader of the Poetry and Prose Reform Movement in the Northern Song Dynasty. After Fan Zhongyan's "Qingli New Deal" failed, Ouyang Xiu was implicated. Ouyang Xiu was demoted to Chuzhou for the trumped-up "Zhang nephew case". Ou Gong's residence in Chu is a political setback, but he can face it calmly and optimistically. In addition to his political affairs, he is intoxicated by the scenery of "mountains all around Chu". historical story. The mountain monk Zhixian respected and admired Ou Gong's academic articles and moral character, and built a pavilion in the middle of the mountain to add to his travels. Ou Gong used "Drunkard" as the name of the pavilion, and from this he created "The Drunkard Pavilion".

# Design Points

结构难点

$$F = G \frac{m_1 m_2}{d^2}$$

Physical operations

物理运算

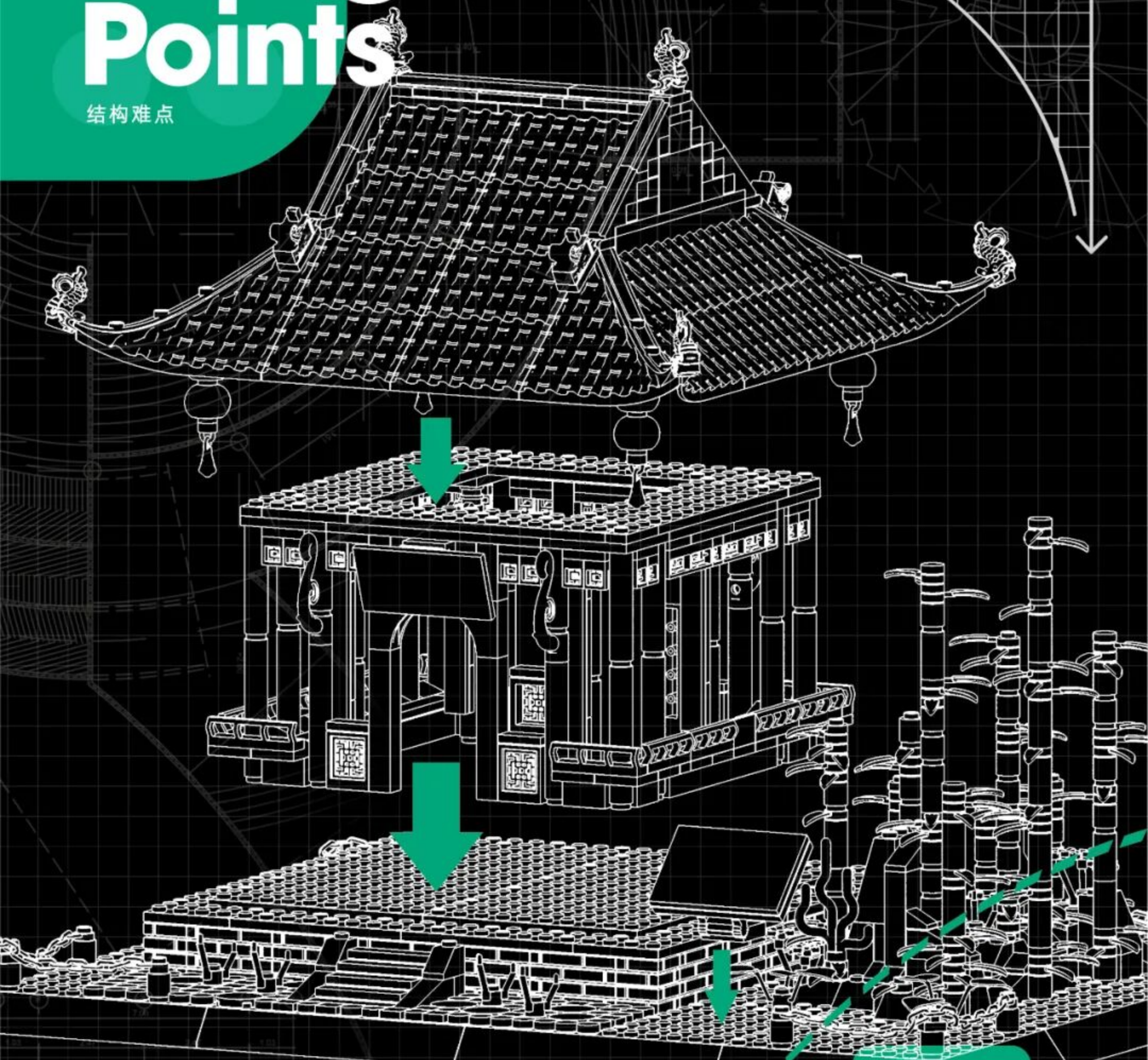

Creation and thinking

创作·思考

# Special parts

特殊零件的开发利用

$$S=4\pi \cdot r^2$$

$$a^2+b^2=c^2$$



**WG1392**  
鱼龙脊兽



**WG1284**  
2孔龙头砖



**WG1427**  
翘角瓦片



**WG534**  
直瓦片6孔

$$\sin^2 a + \cos^2 a = 1$$



features and functions

特点.功能

# Main Color Matching

配色方案



Pantone Cool Gray 6C

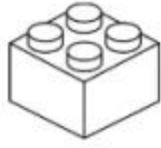

White



Pantone Black 6C



Pantone 7620C



Pantone 123C



Pantone 7500C



Pantone 2300C



Pantone 431C



Pantone 348C



Pantone 7509C



Pantone 7427C



## Color matching

Adopting 3 main colors, Black, Jujube red and dark green as the main color, the more reasonable and Beige color matching on the original building, making the product more atmospheric and the whole design is more reasonable.

# Zuiweng Pavilion

中国安徽醉翁亭



Front

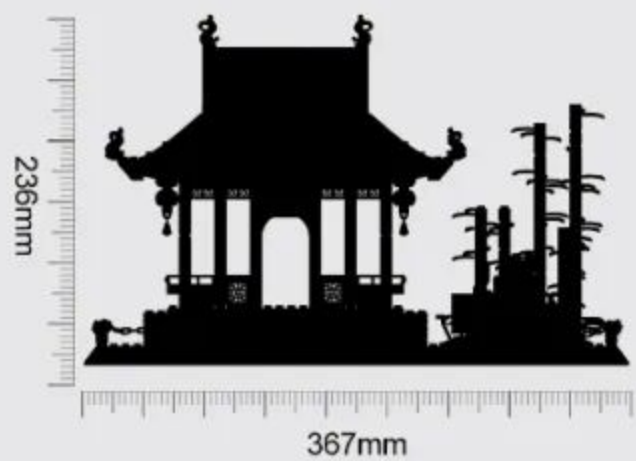

Left

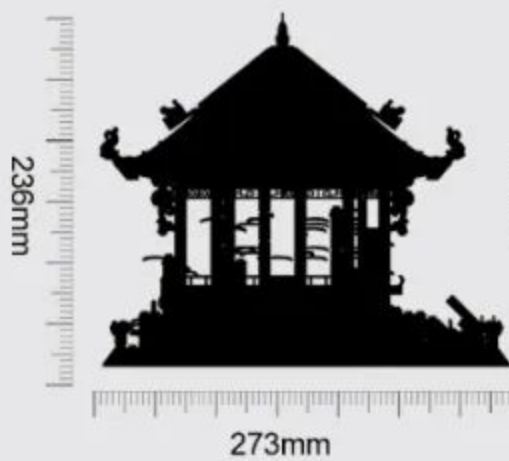

Back

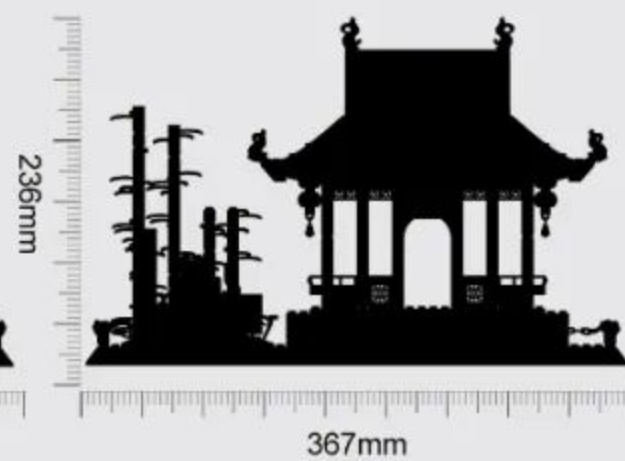

Product Size:367X273X236mm





■ First open the product packaging according to the instructions.

按指导用正确方式拆解产品外包装。



■ Summarize all parts to count the number of familiar accessories.

对照说明书清单确认积木包数量与积木数量。



■ Arranging all accessories by color helps to quickly install the product.

把确认好的积木以类型、颜色进行分类排好以便安装。



■ Carefully install the product and learn about building.

按说明书步骤拼装并完成你的积木模型。



# Instructions For Use

积木起件器使用说明  
Brickseparator

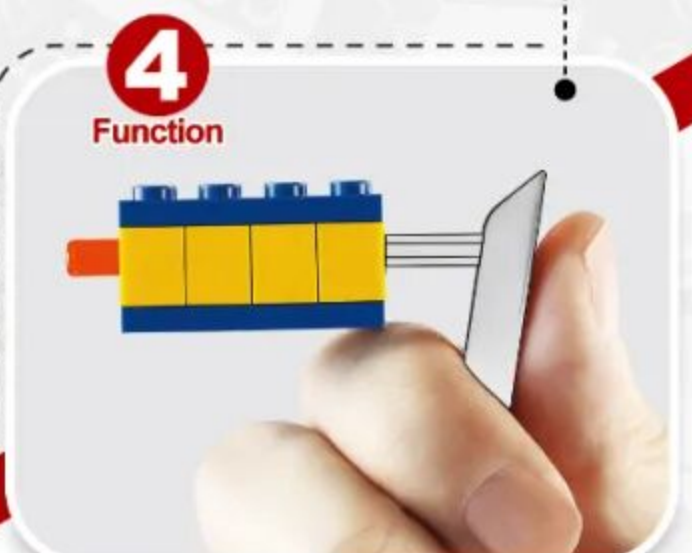
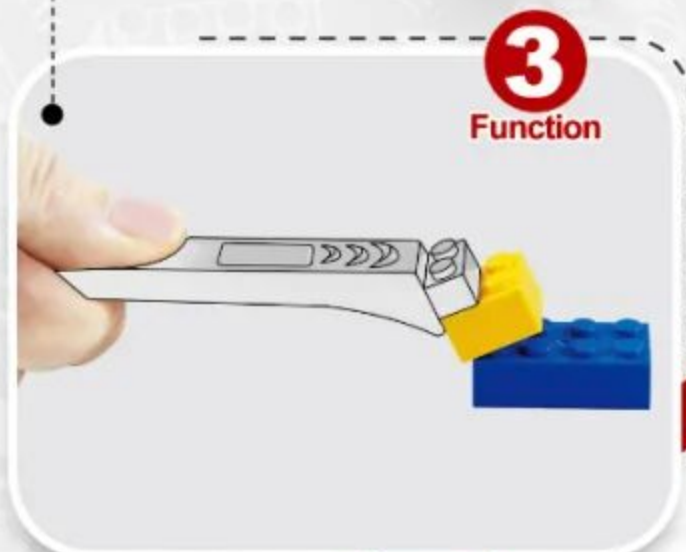
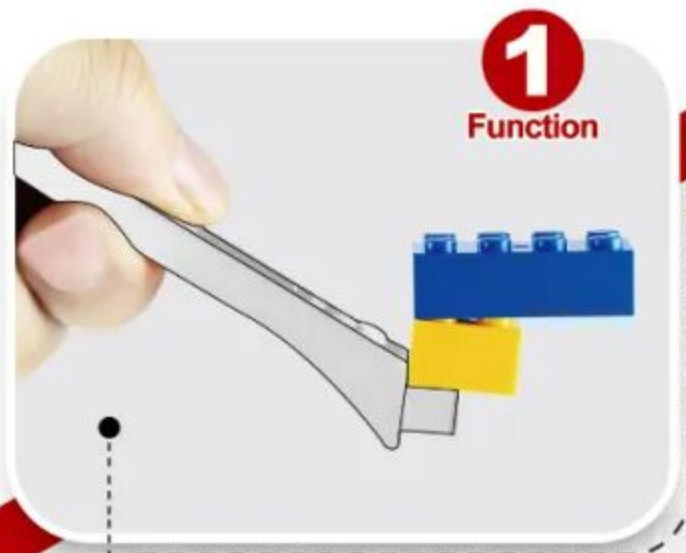

4 ways to make installation easier  
让安装更简单

# 1:1 Physical Reference Table

十字棒配件1:1尺寸参照表



Instructions For Use  
让安装更简单



**2**  $(1 \times 2) = 2$

**3**  $(1 \times 3) = 3$

**4**  $(1 \times 4) = 4$

**5**  $(1 \times 5) = 5$

**6**  $(1 \times 6) = 6$

**7**  $(1 \times 7) = 7$

**8**  $(1 \times 8) = 8$

**9**  $(1 \times 9) = 9$

**10**  $(1 \times 10) = 10$

**12**  $(1 \times 12) = 12$

**16**  $(1 \times 16) = 16$



# PARTS LIST

配件清单

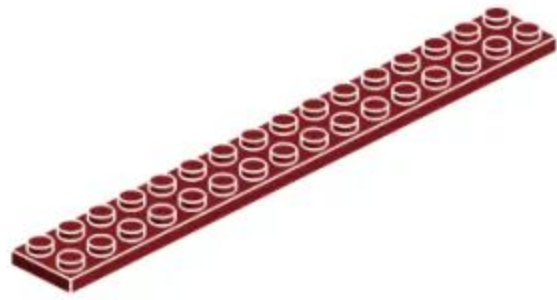

x2

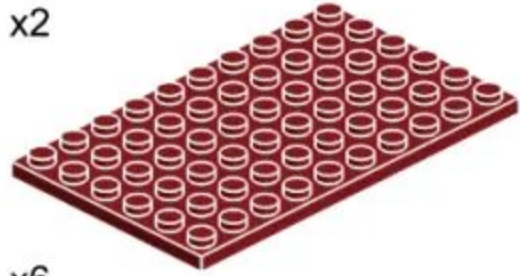

x6



x4



x8



x2



x6



x2



x4



x2



x1



x1



x3



x4



x4



x4



x4



x4



x12



x4



x12



x16



x4



x4



x8



x4

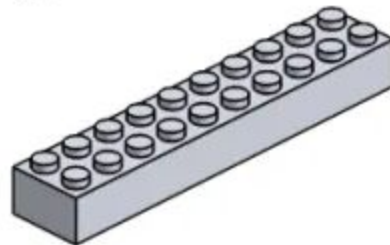

x1

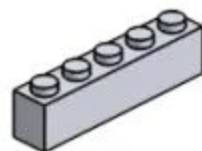

x2



x4



x7



x6

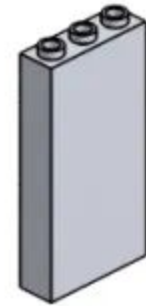

x1



x1



x2



x2



x1

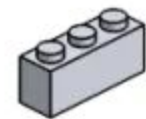

x1



x1

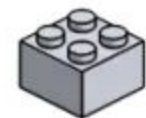

x1



x1



x2



x3



x4



x4



x11



x5













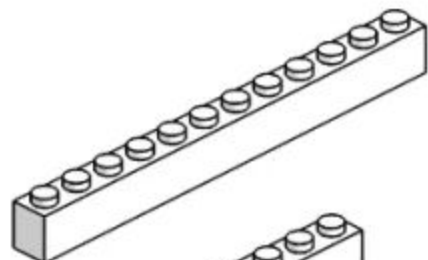



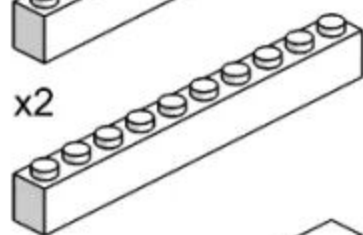





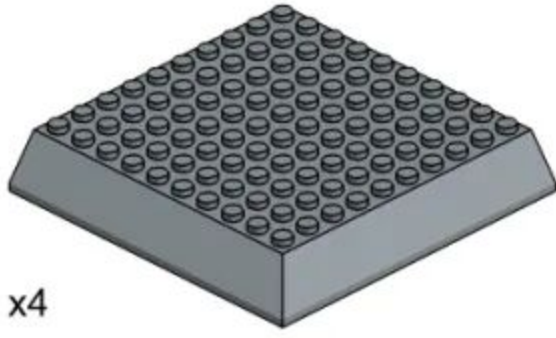



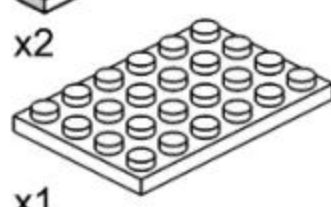

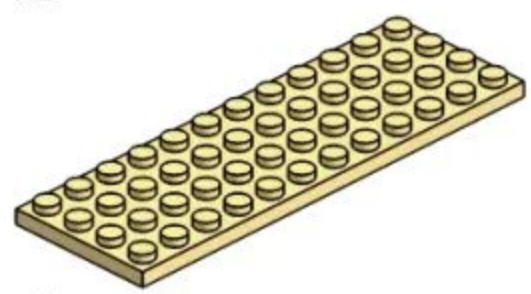

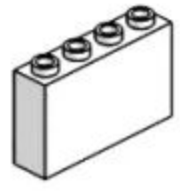

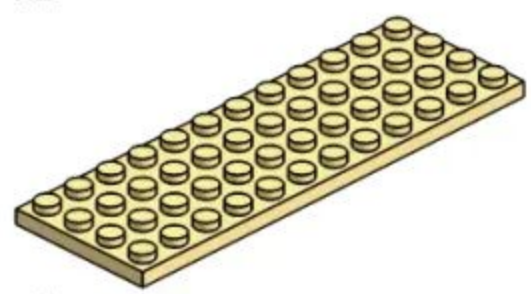
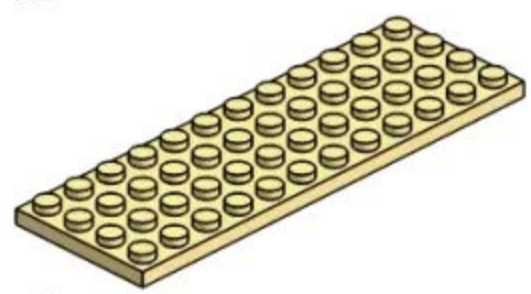

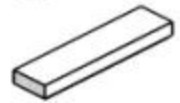



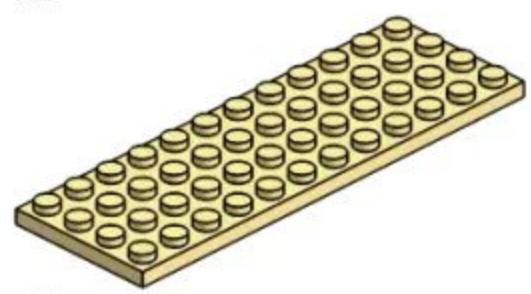
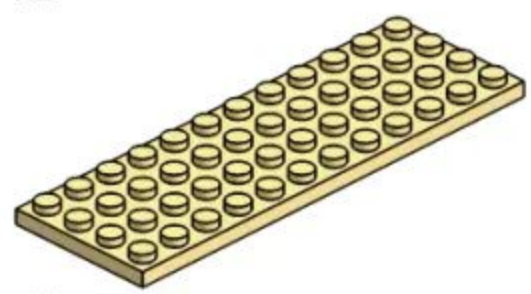
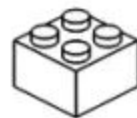

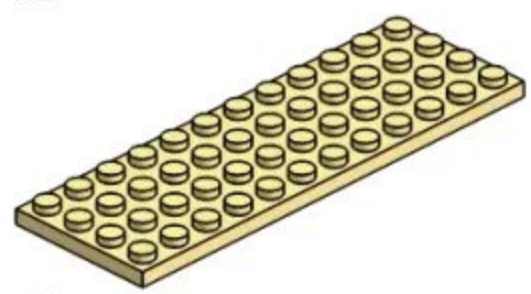

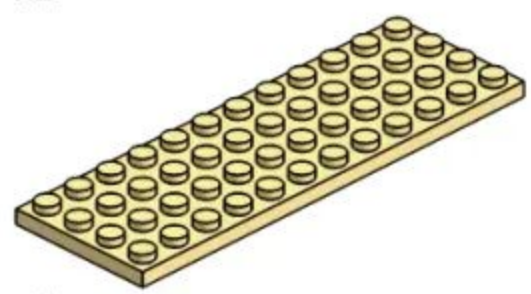
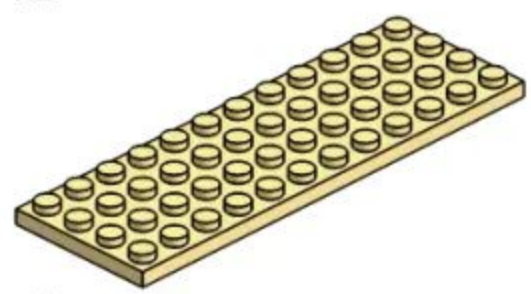

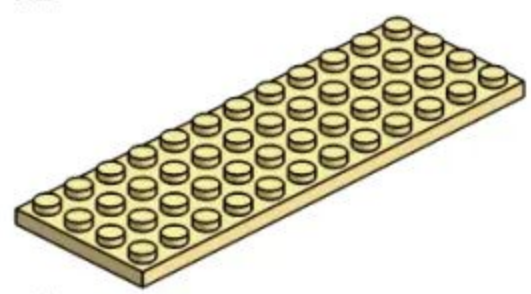
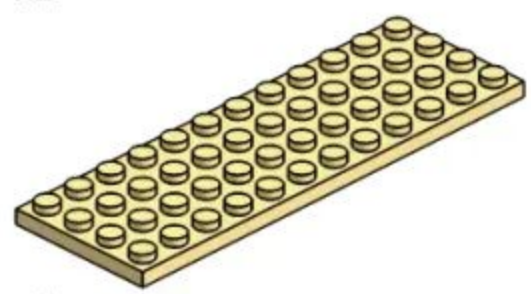

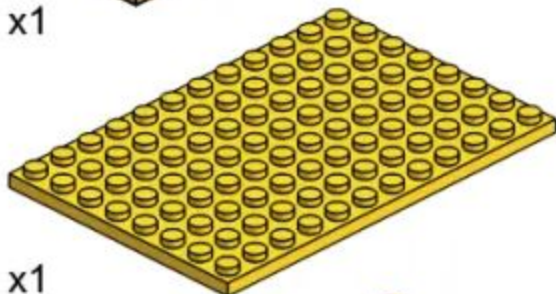
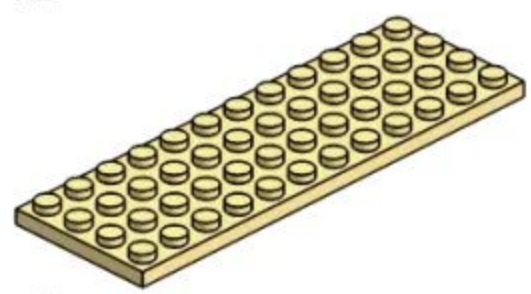
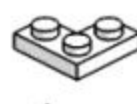
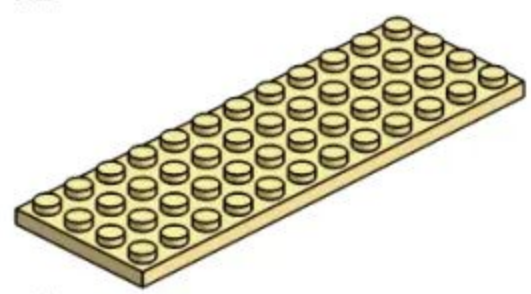
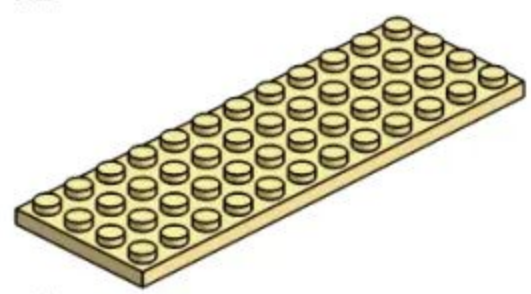

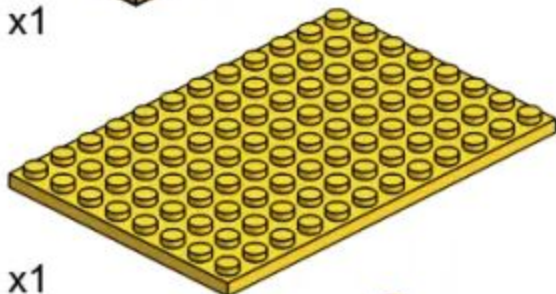
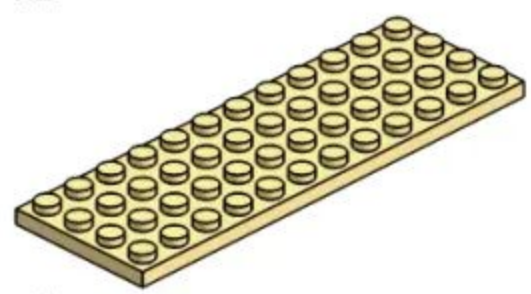
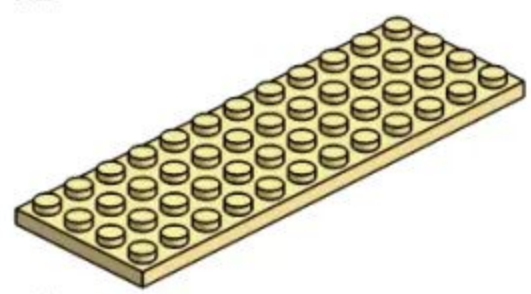

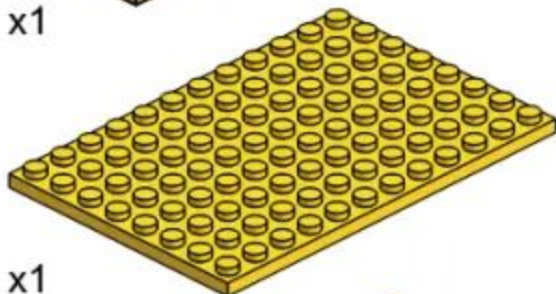
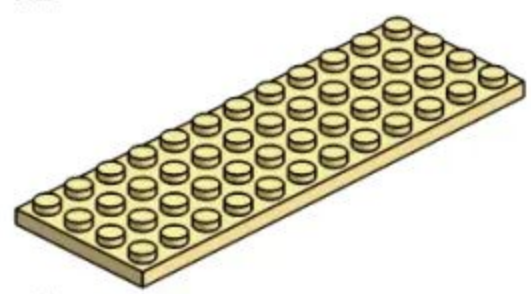
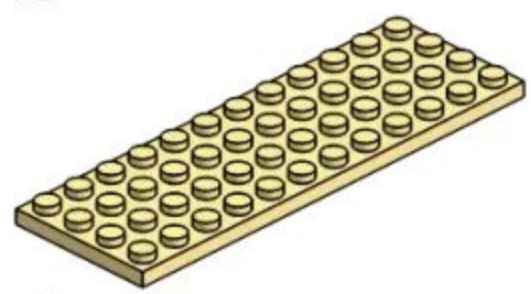

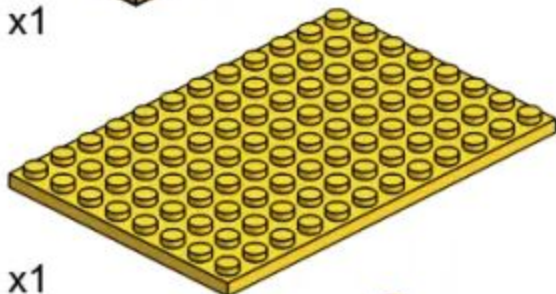
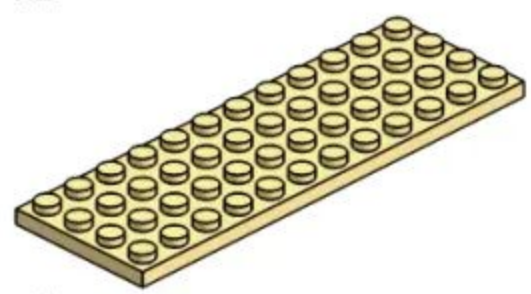
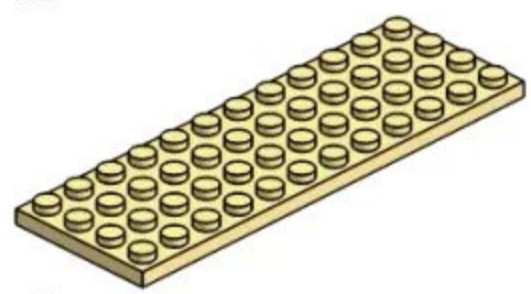
x12

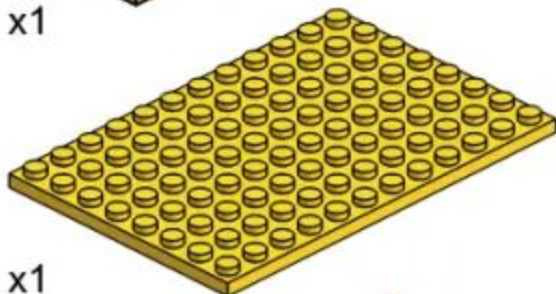
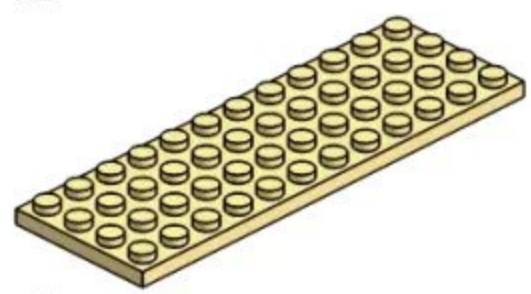
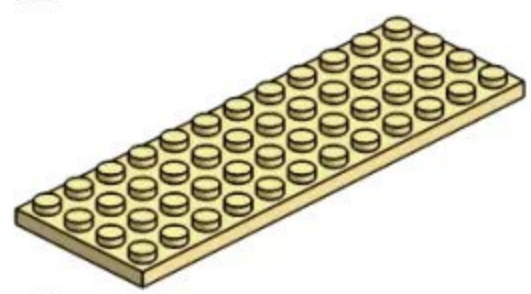
产品有增补件请以实物为准

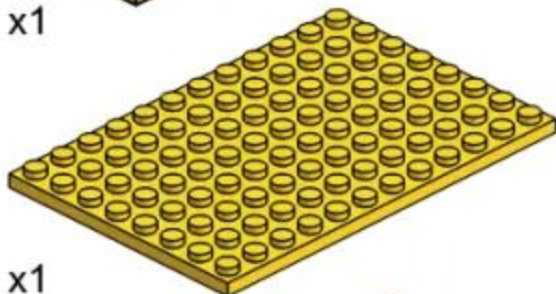
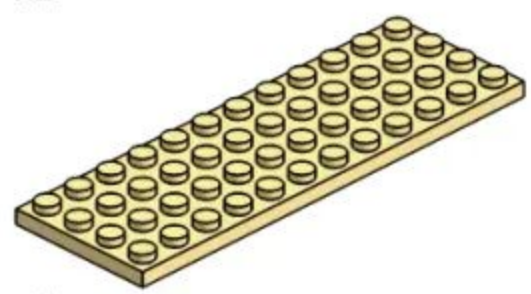
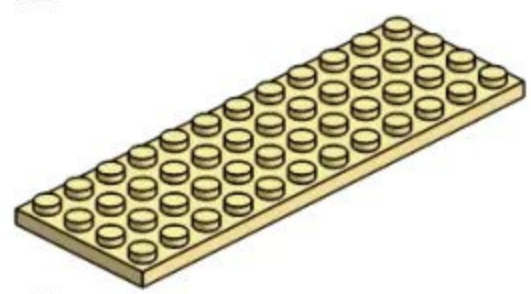
If product has additional parts, please in kind prevail.

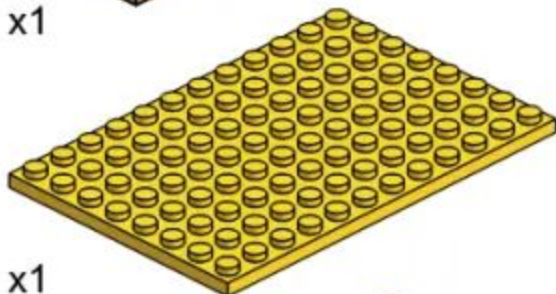
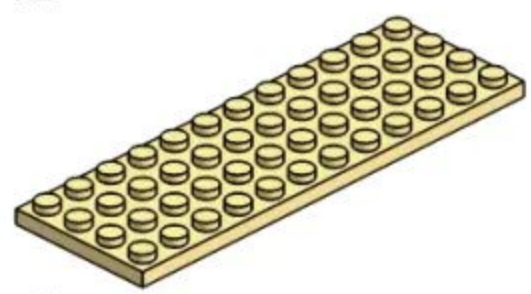
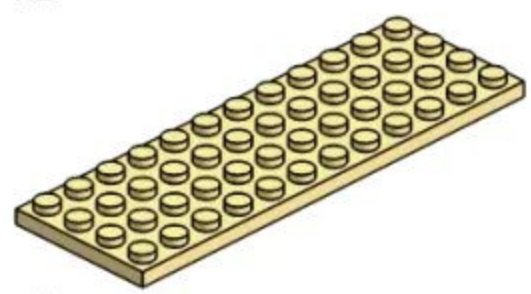
# PARTS LIST

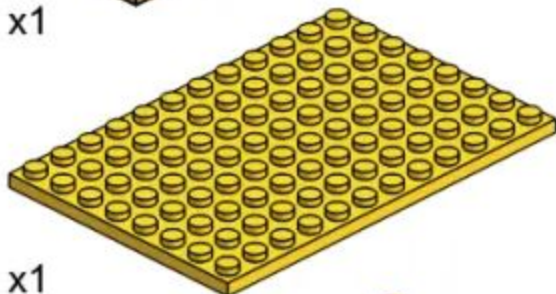
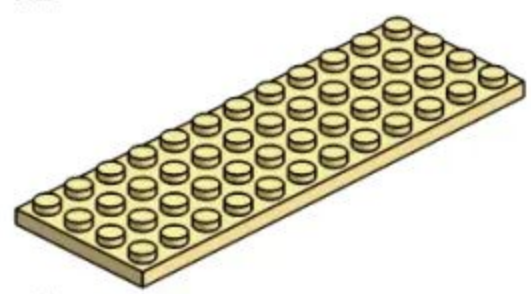
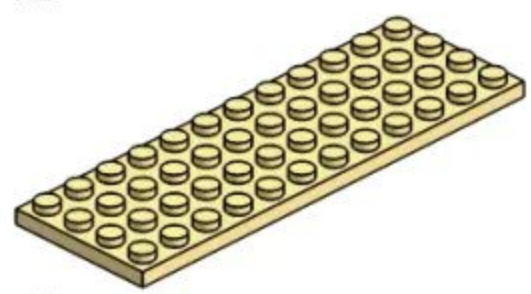
配件清单

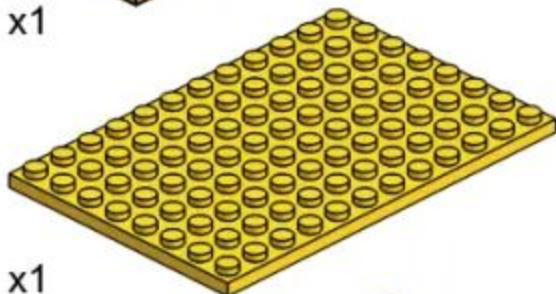
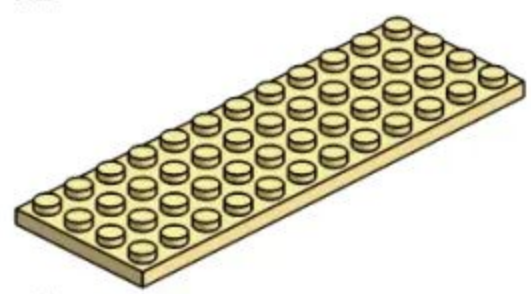
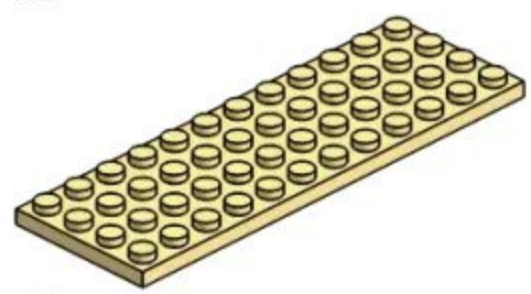
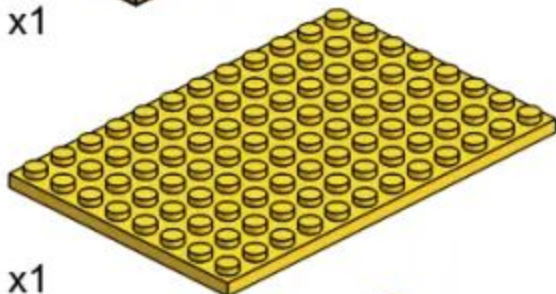
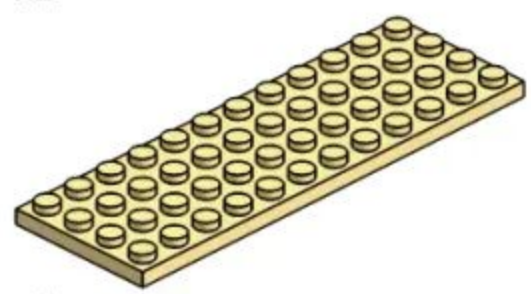
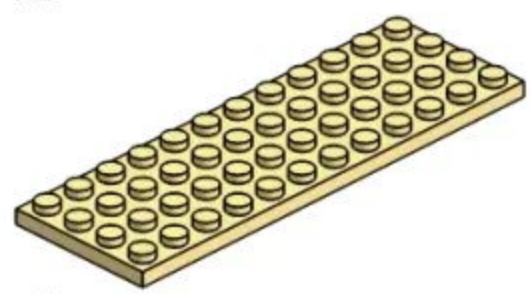
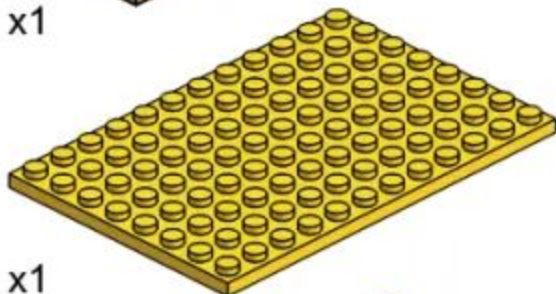
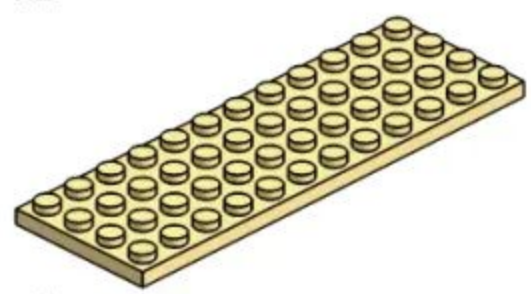
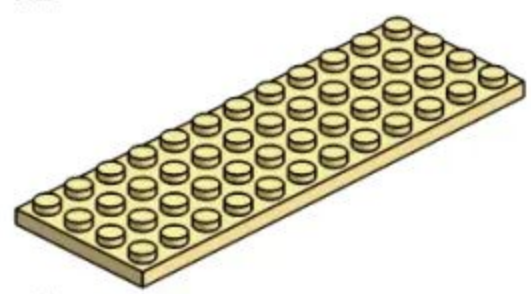
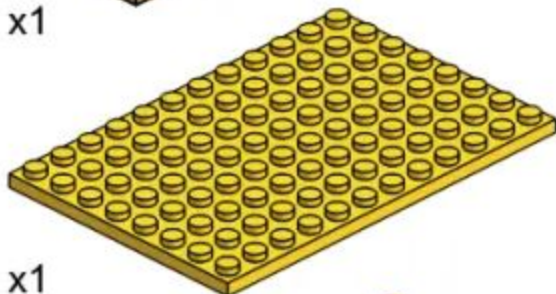
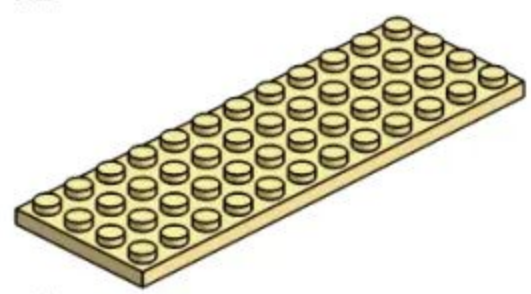
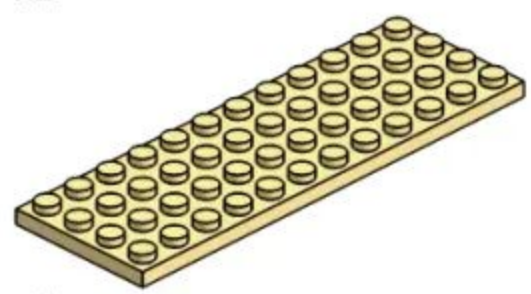
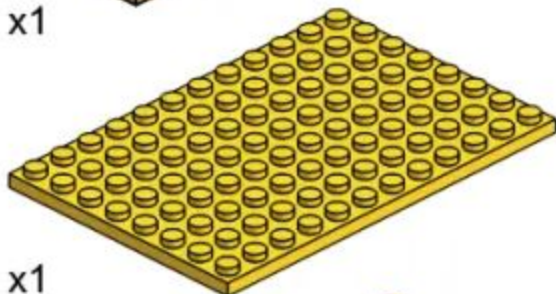
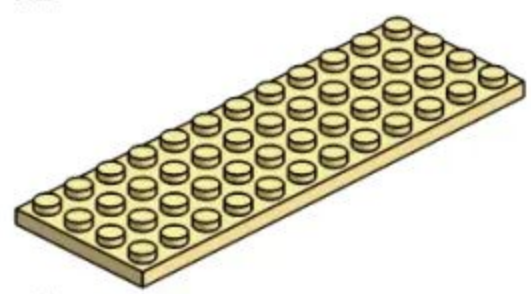
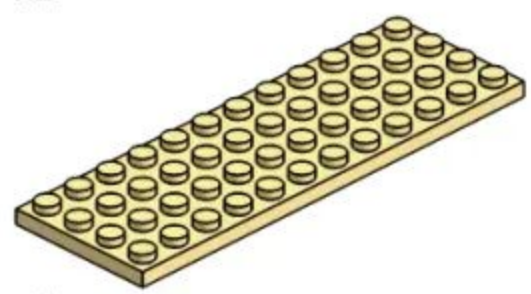
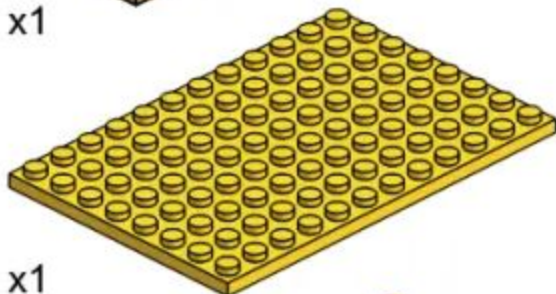
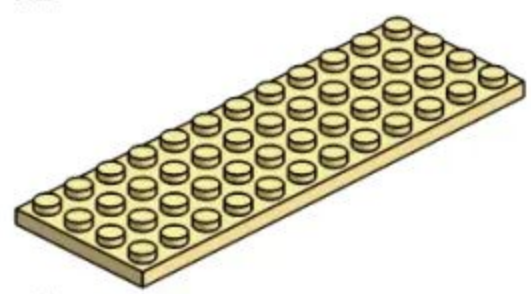
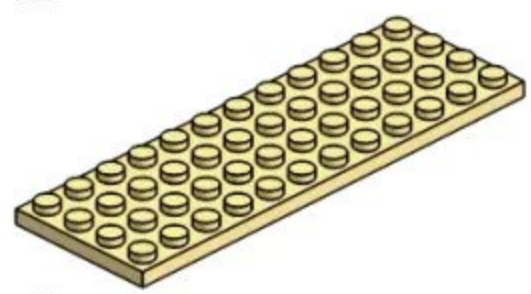
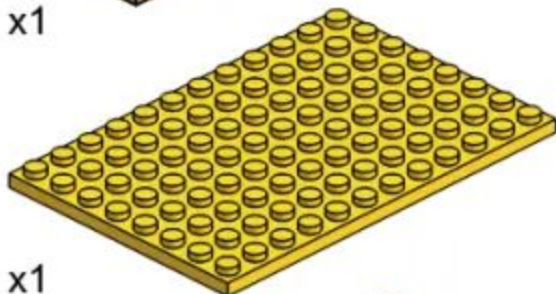
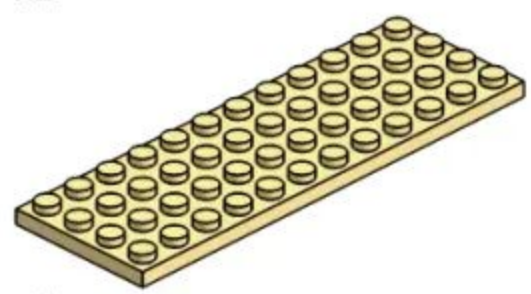
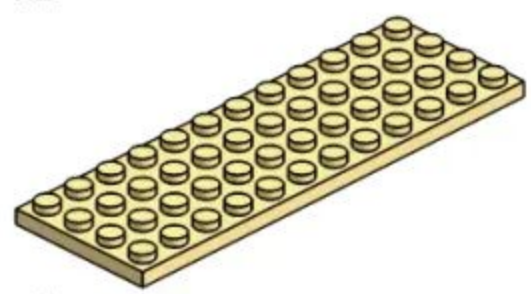
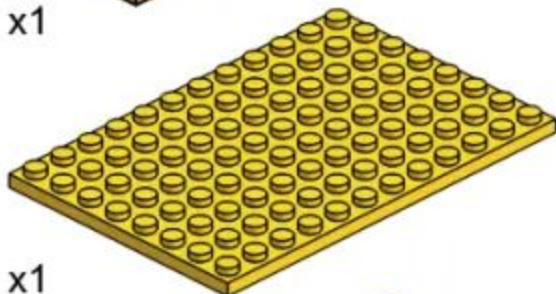
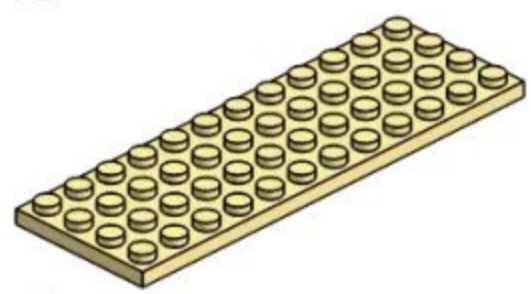
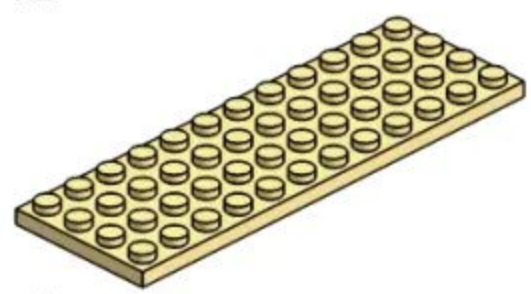
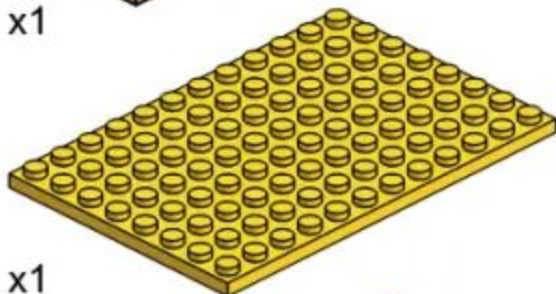
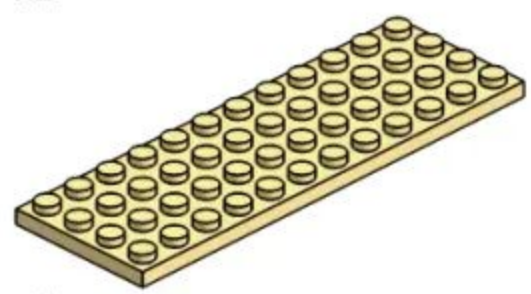
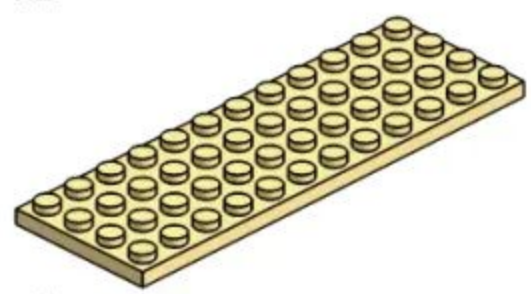
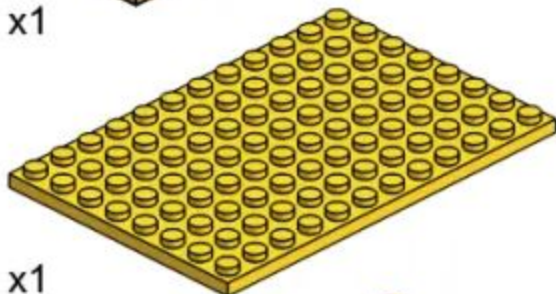
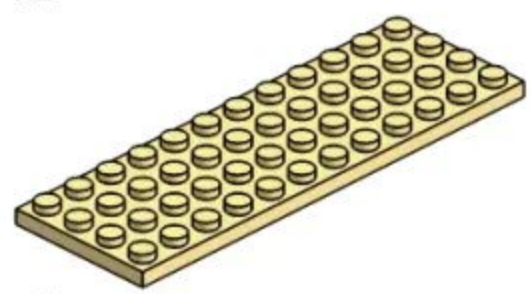
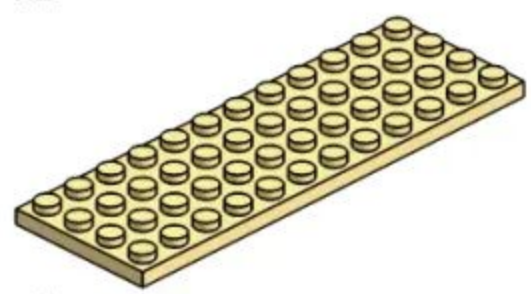
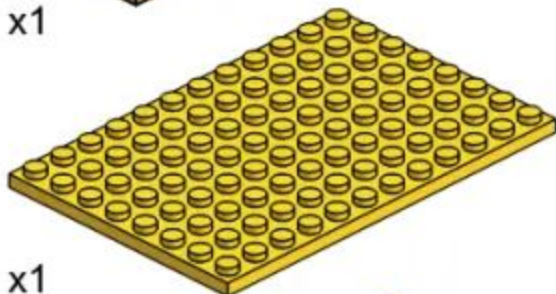
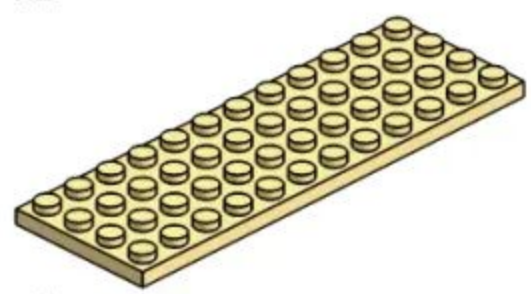
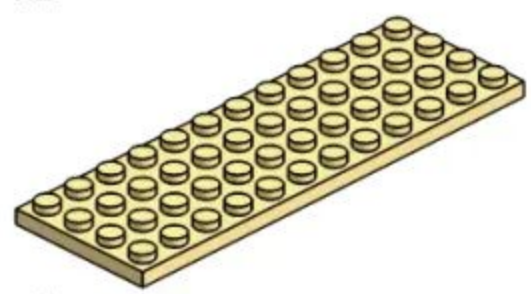
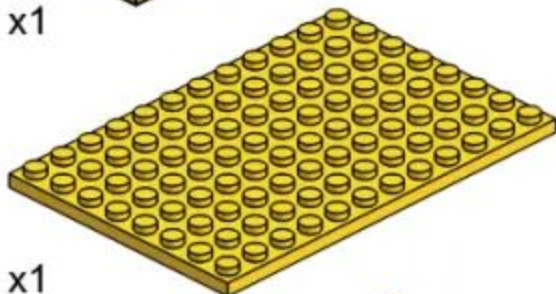
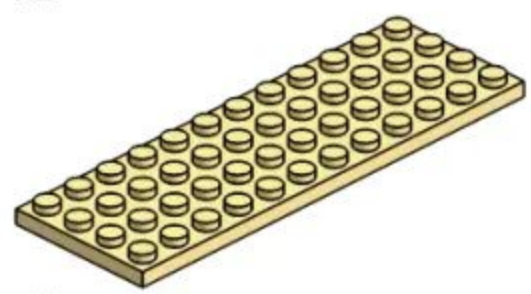
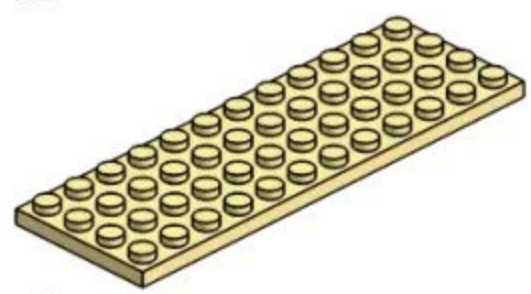
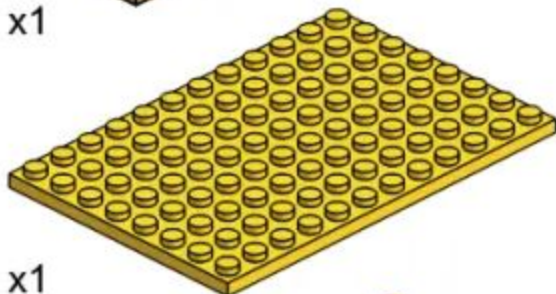
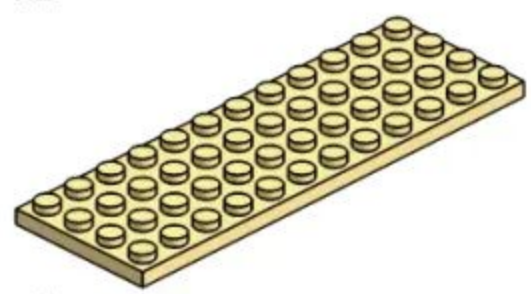
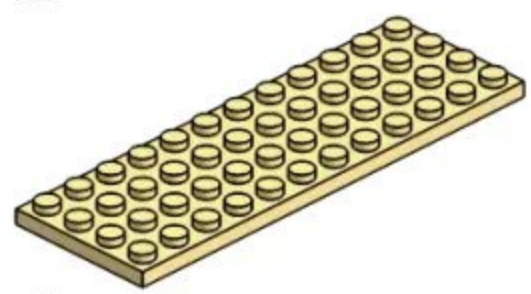
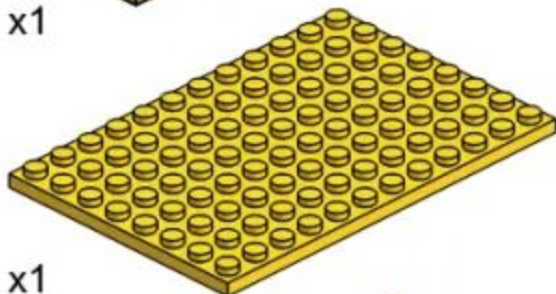
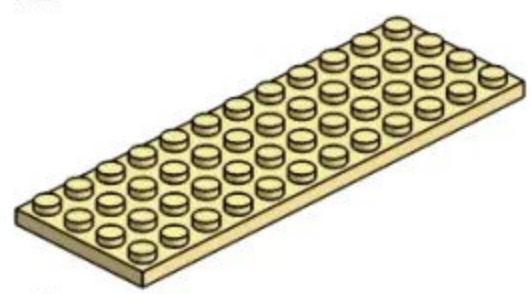
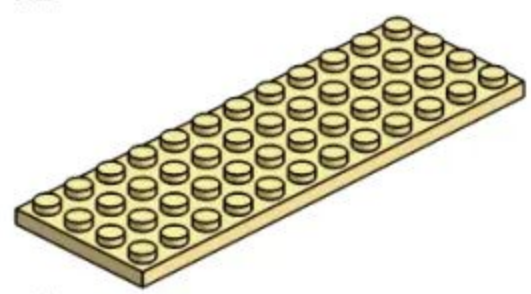
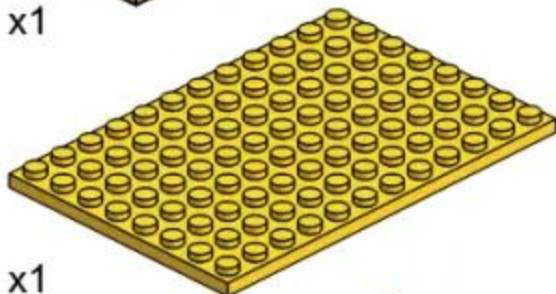
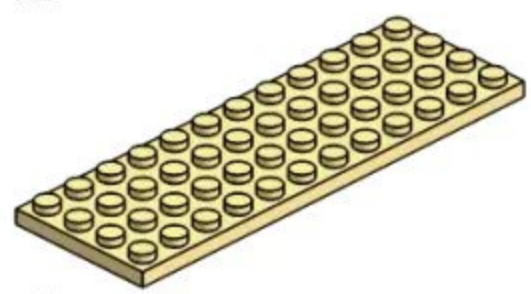
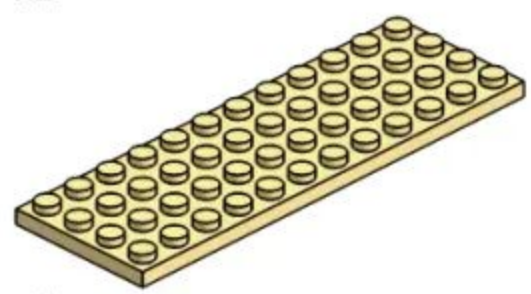
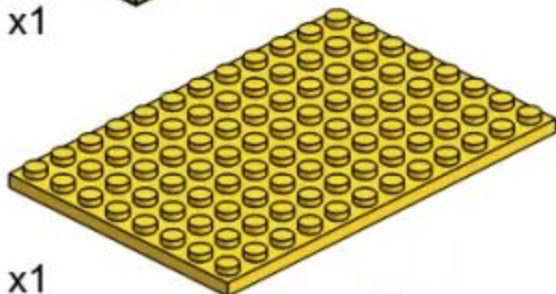
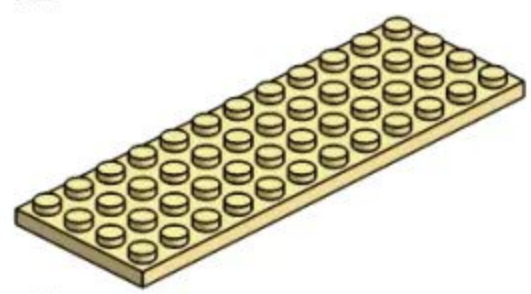
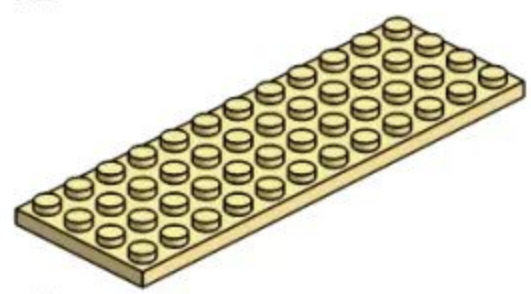
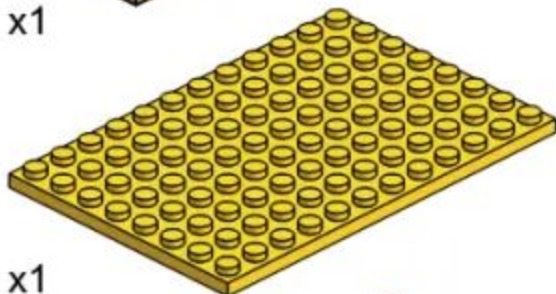
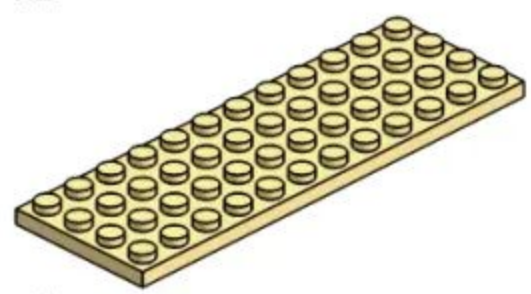
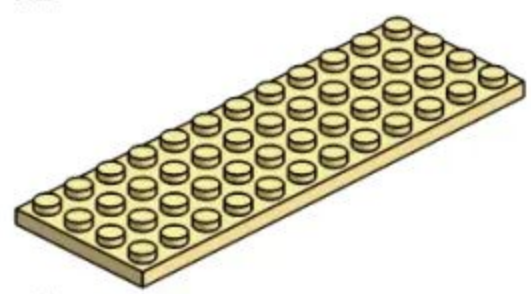
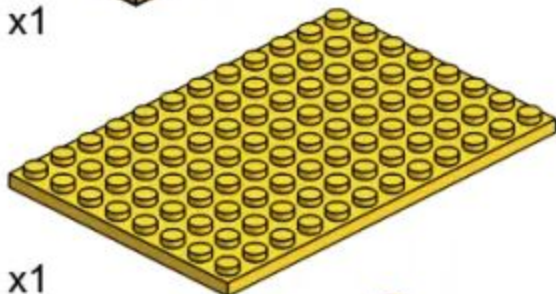
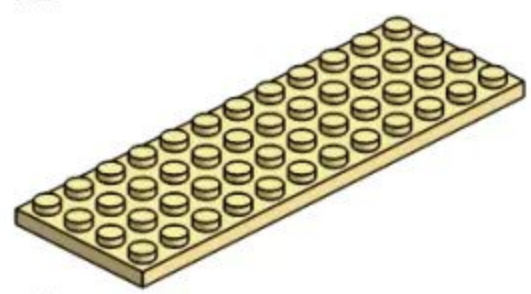
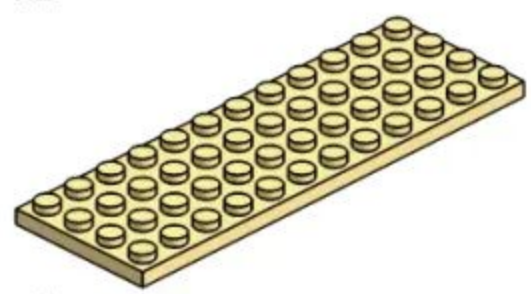
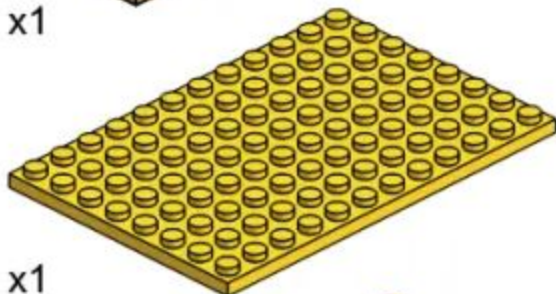
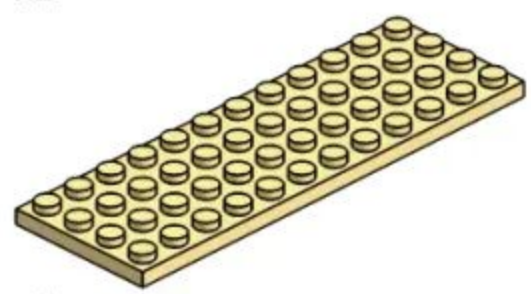
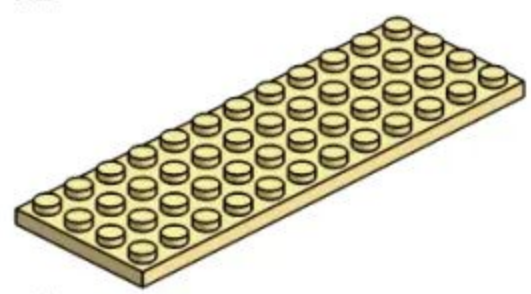
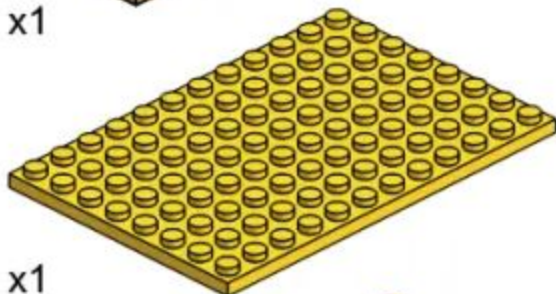
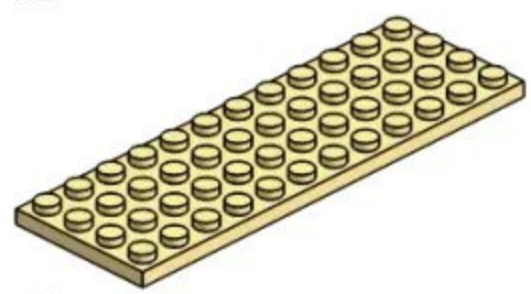
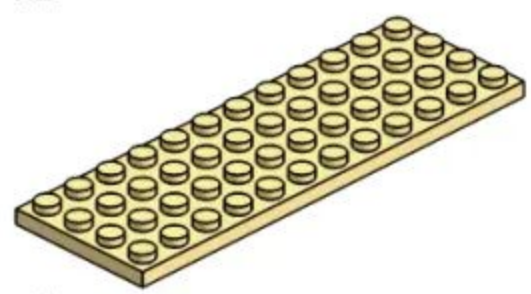
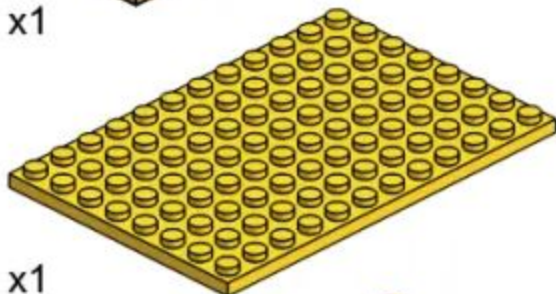
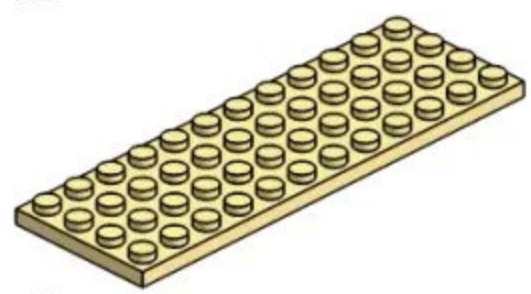
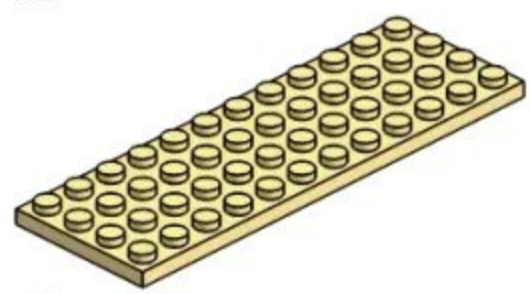
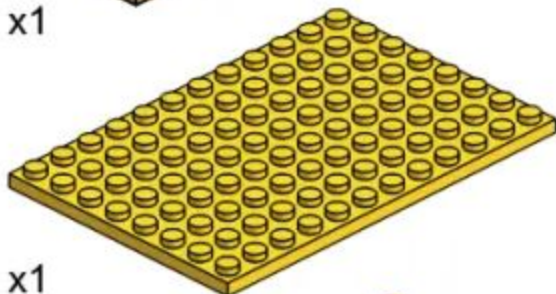
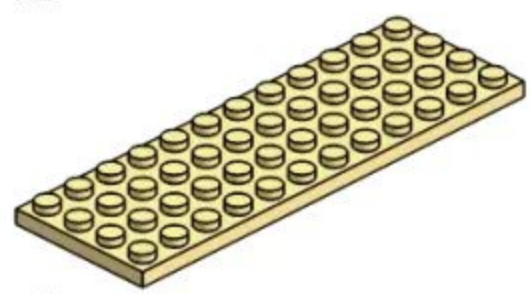
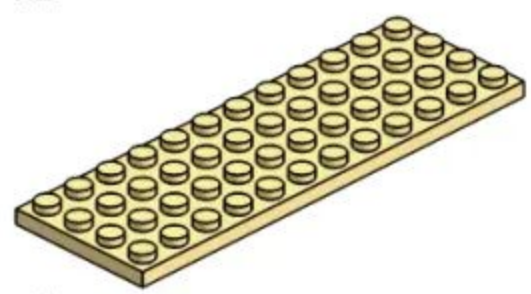
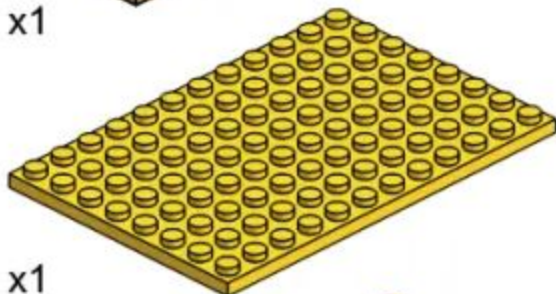
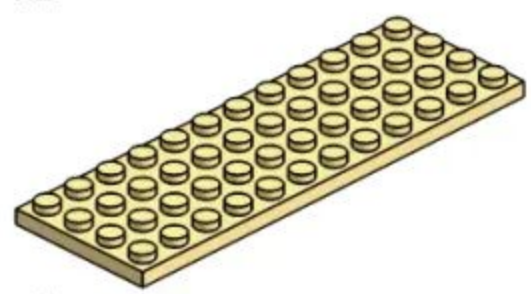
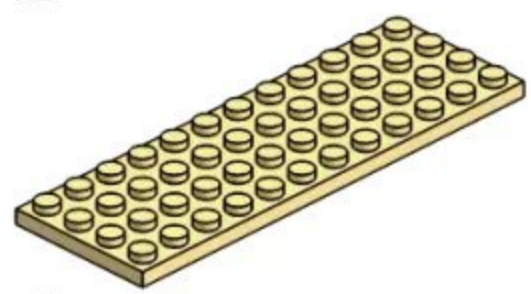
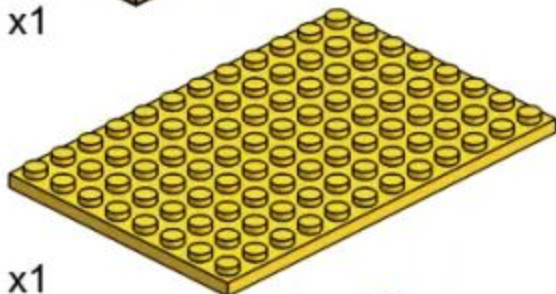
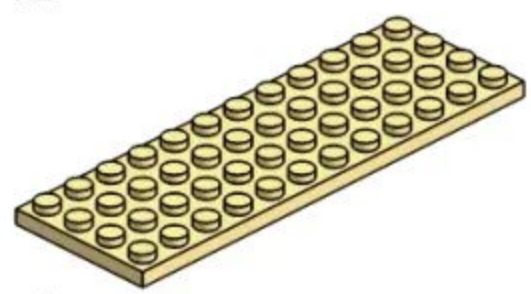
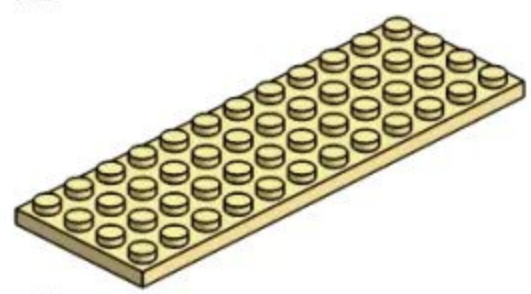
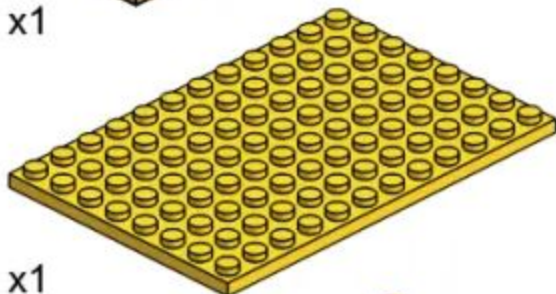
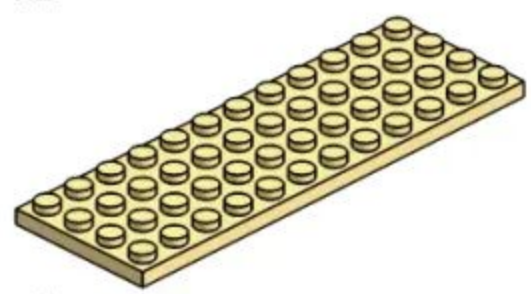
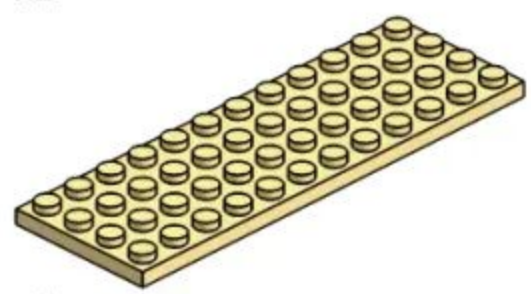
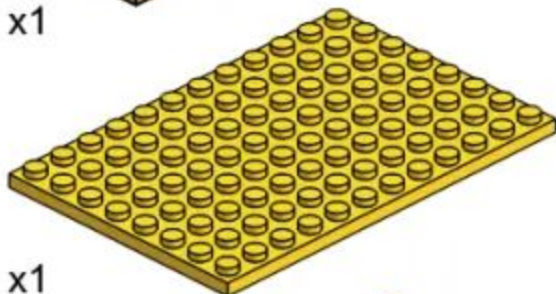
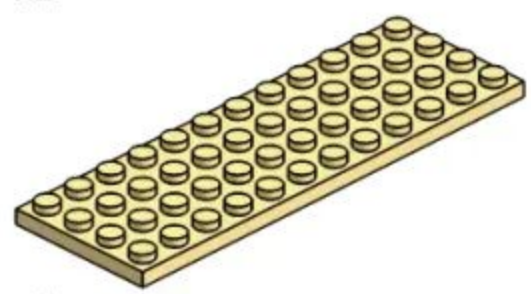
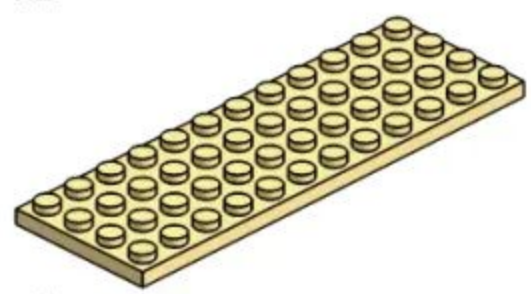
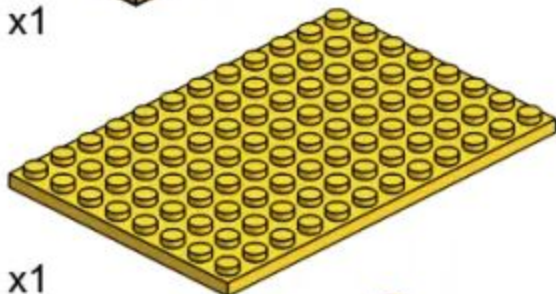
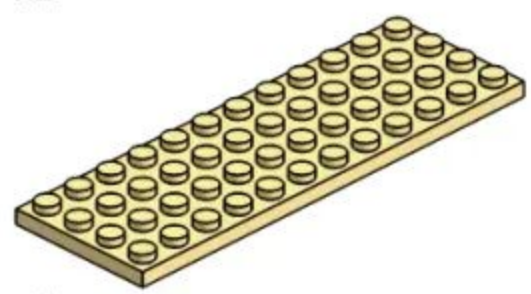
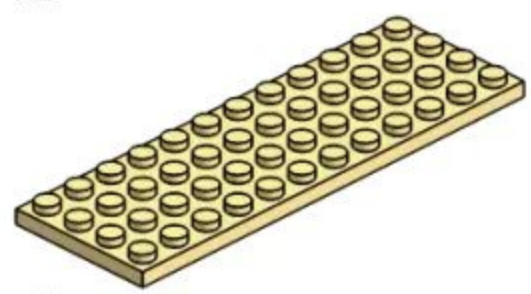
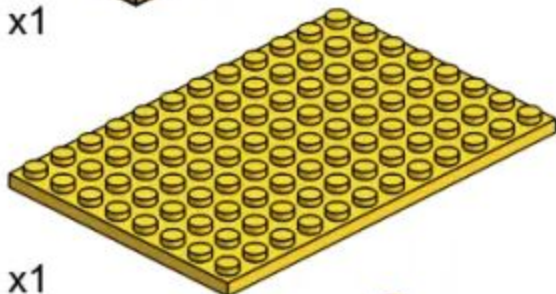
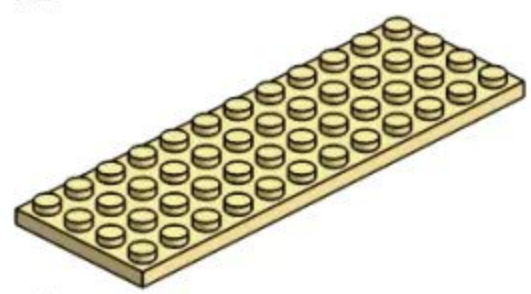
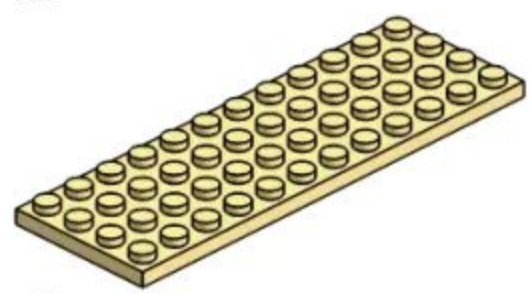
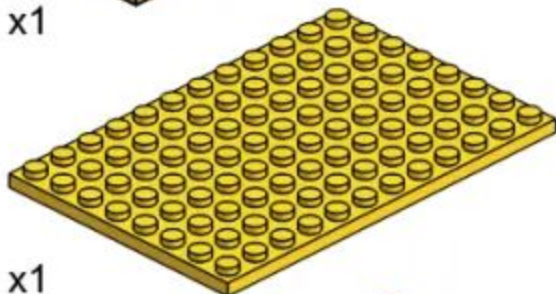
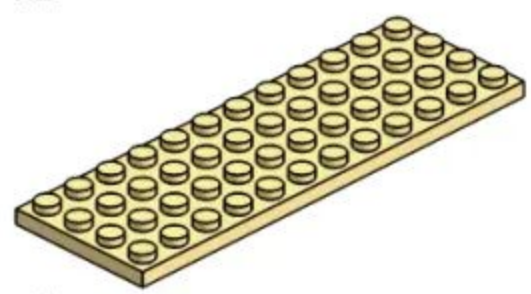
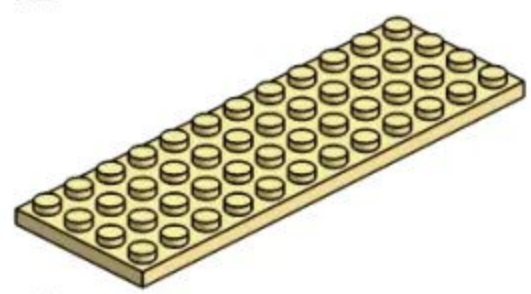
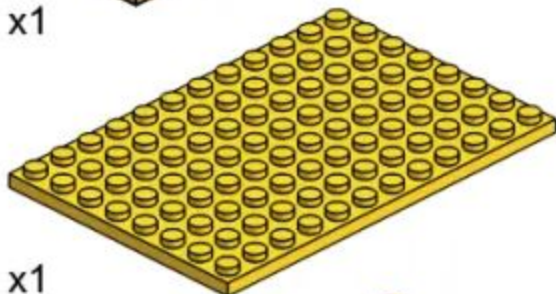
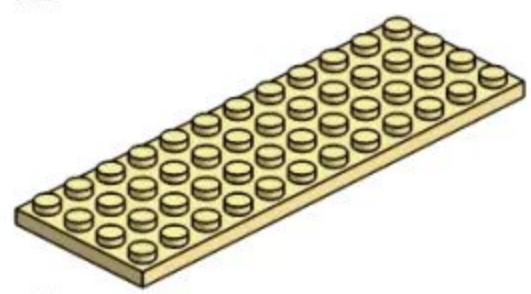
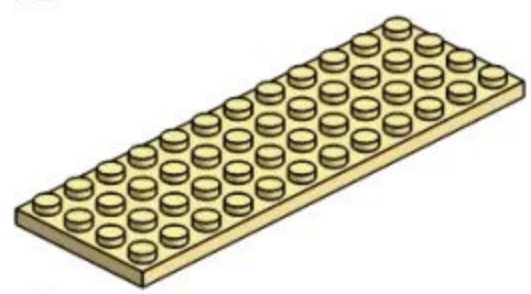
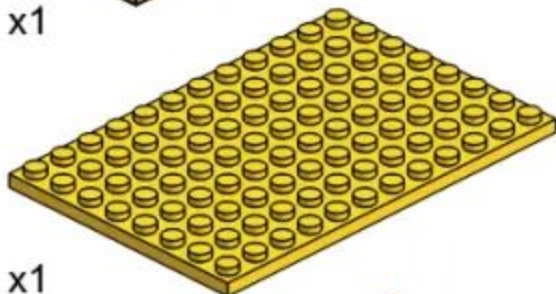
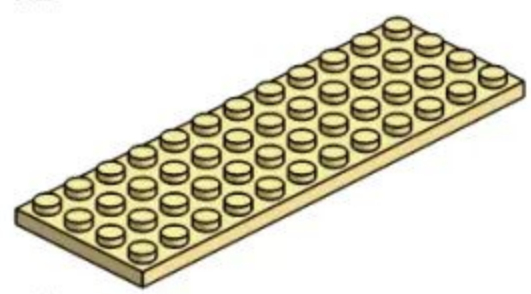
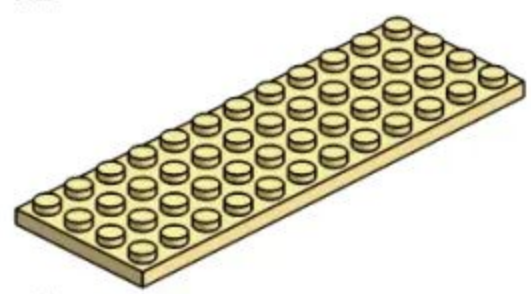
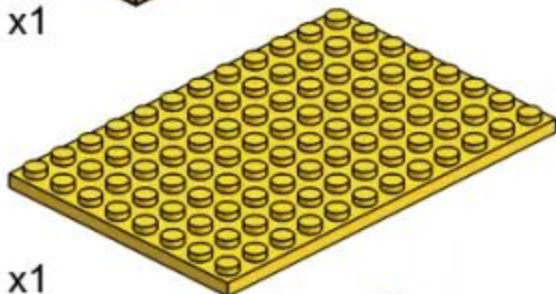
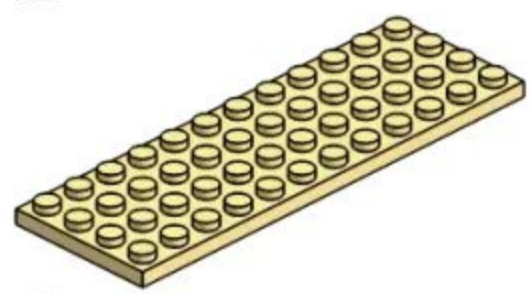
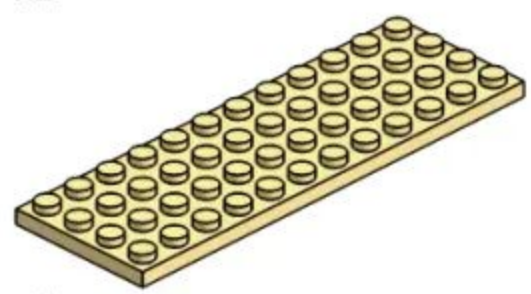
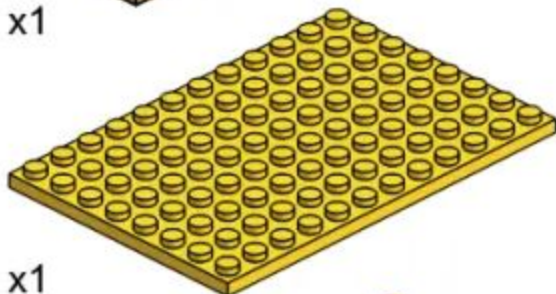
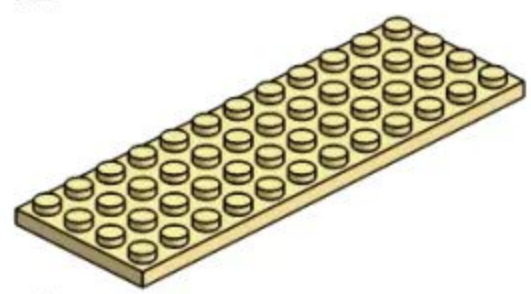
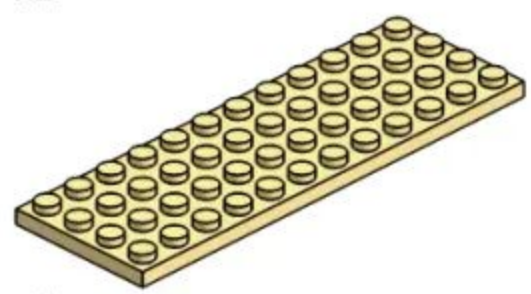
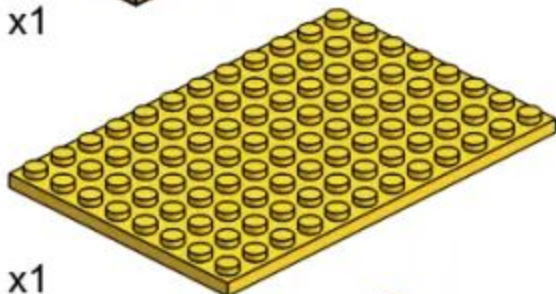
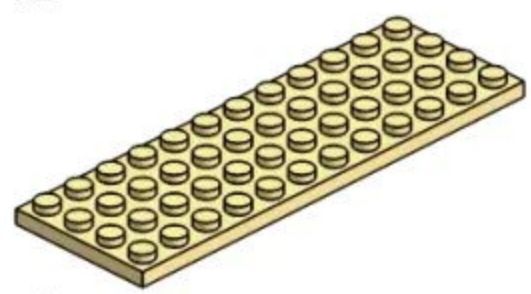
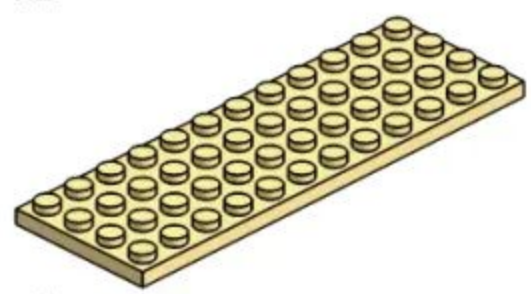
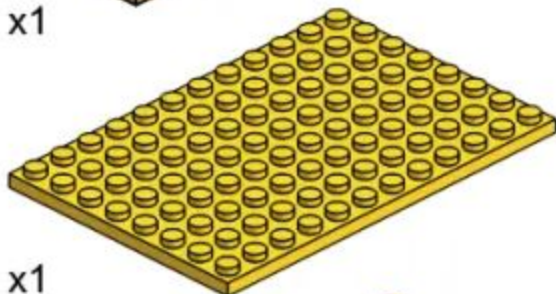
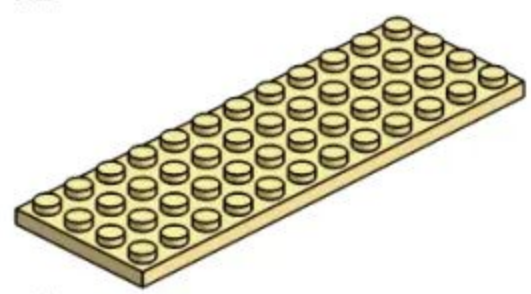
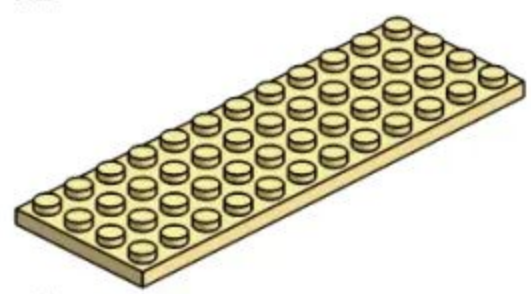
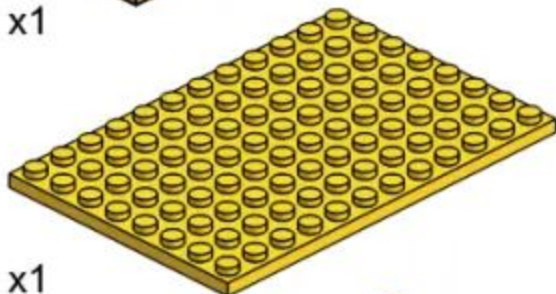
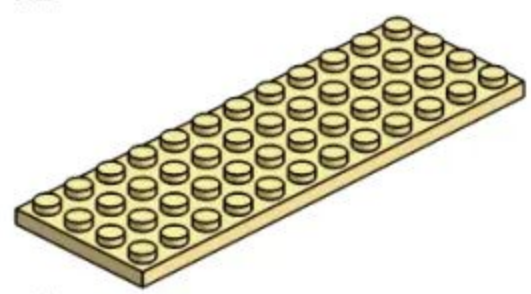
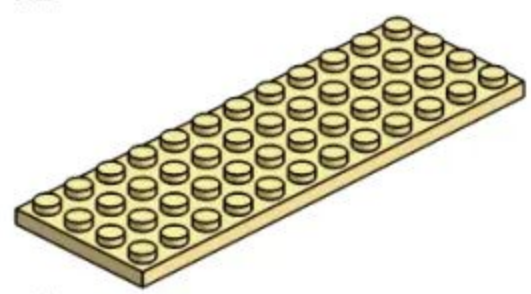
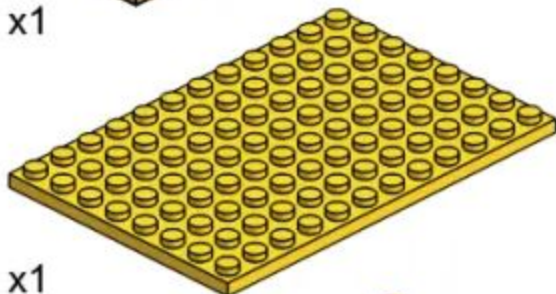
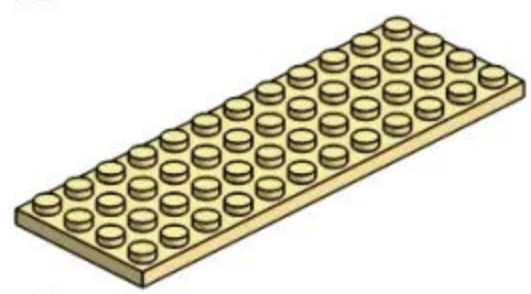
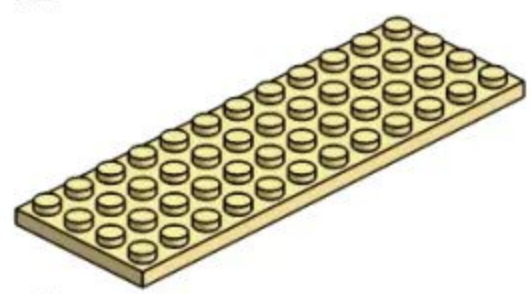
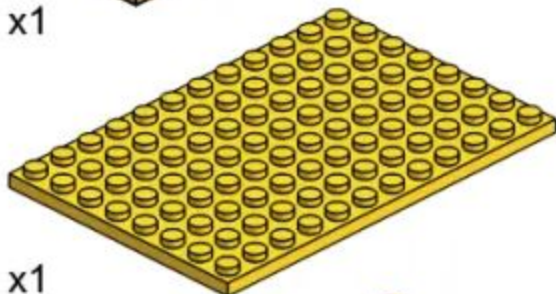
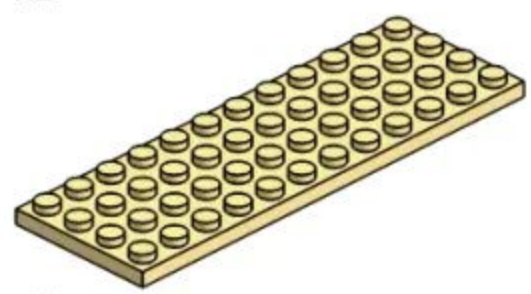
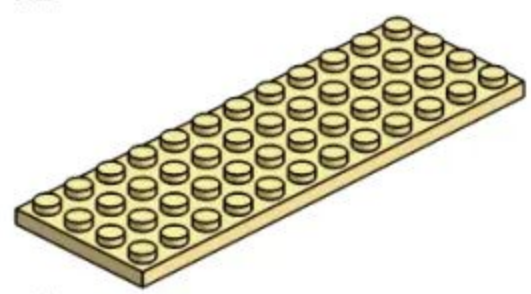
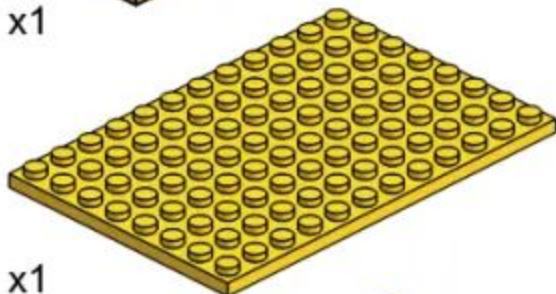
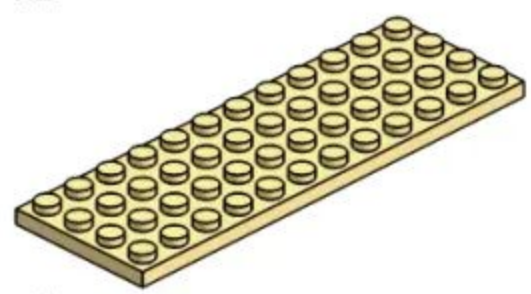
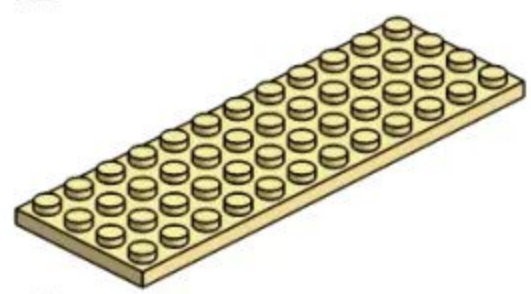
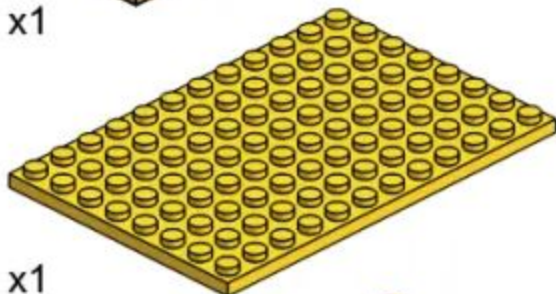
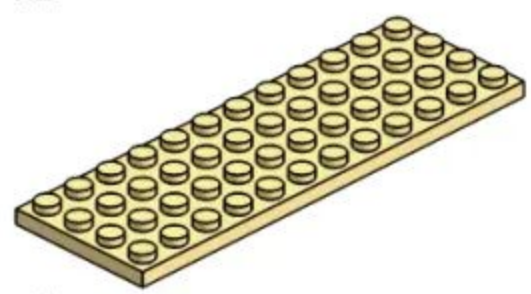
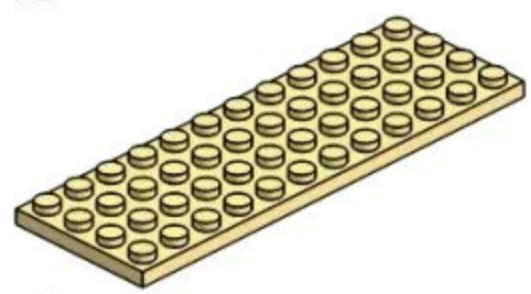
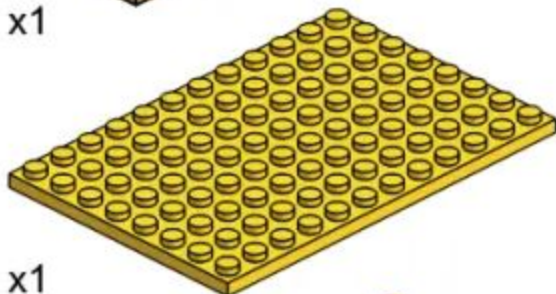
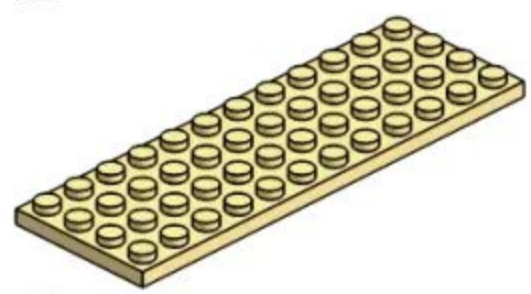
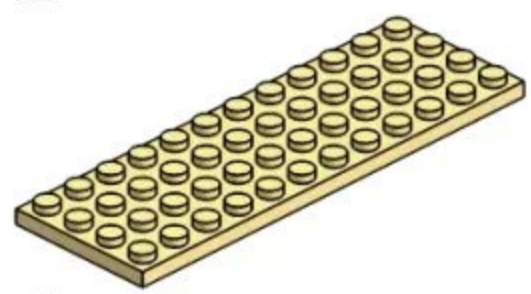
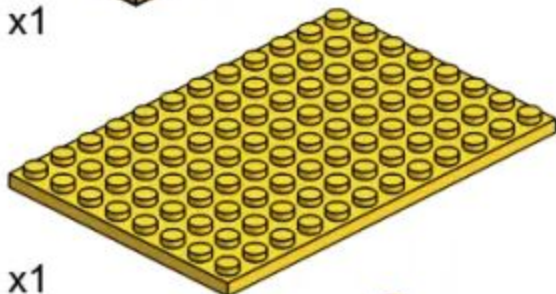
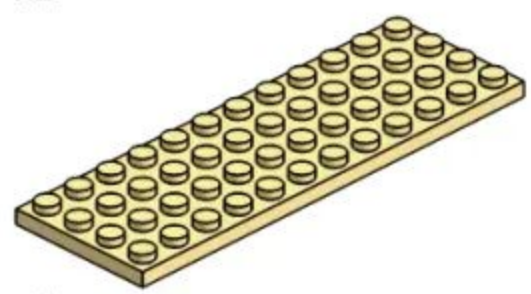
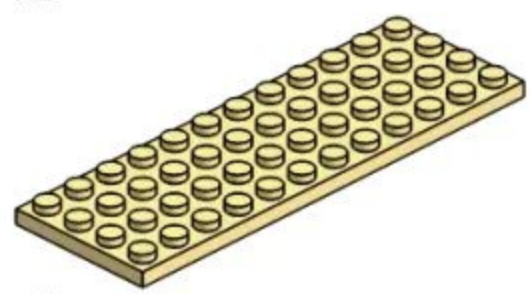
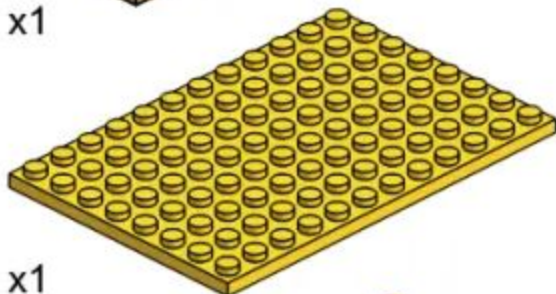
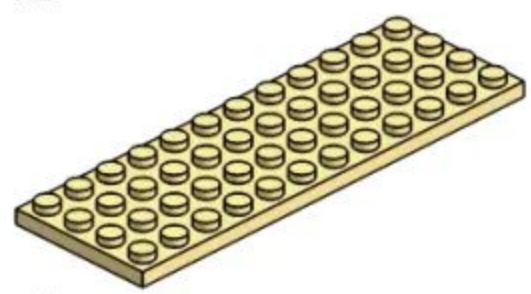
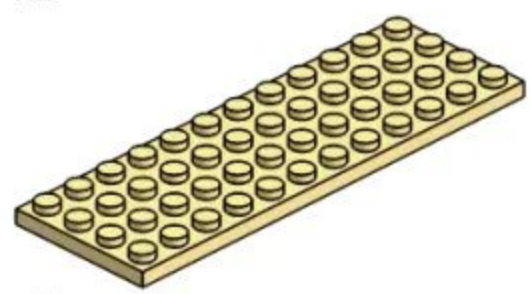
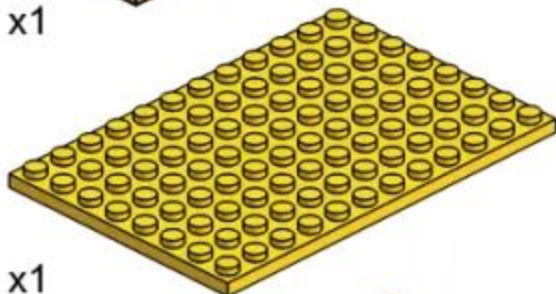
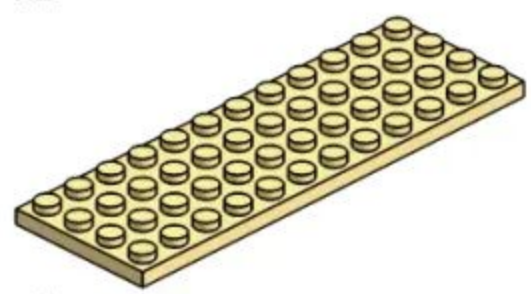
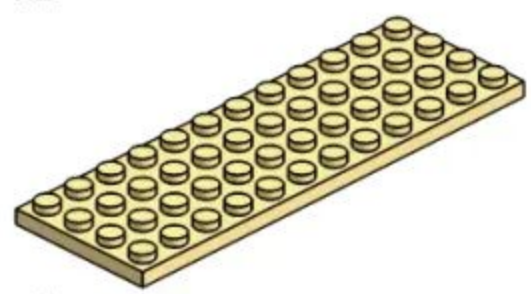
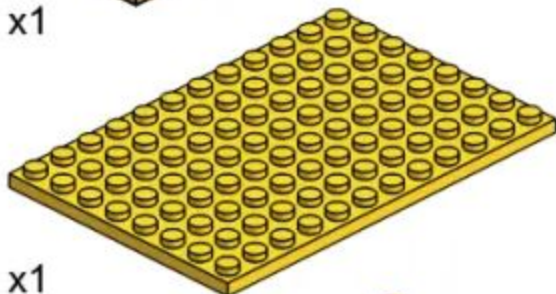
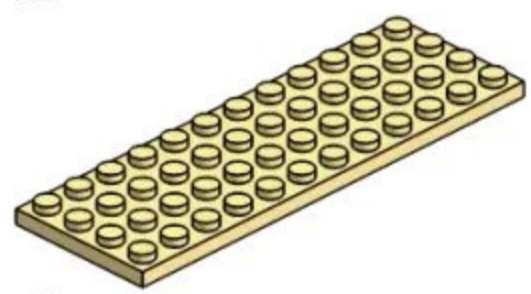
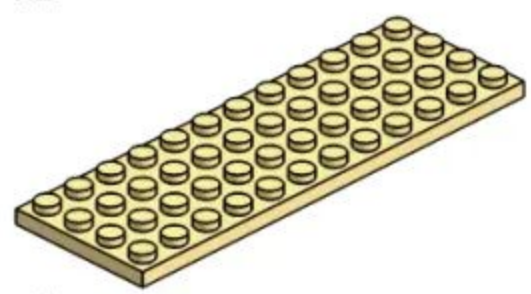
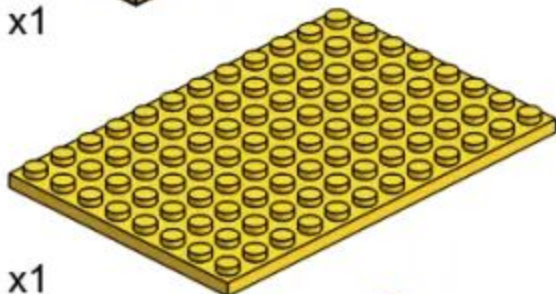
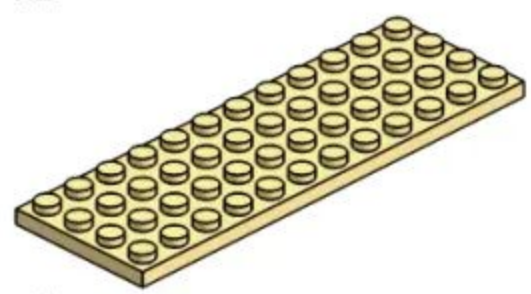
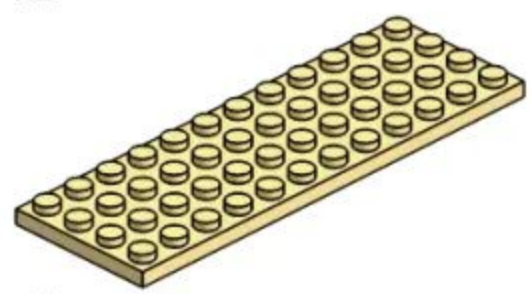
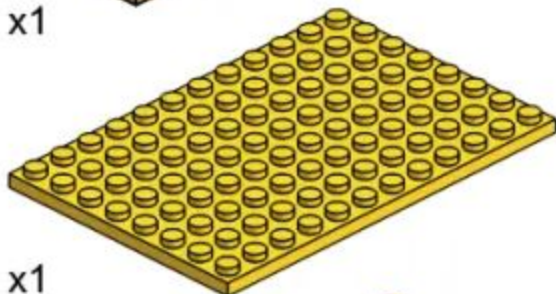
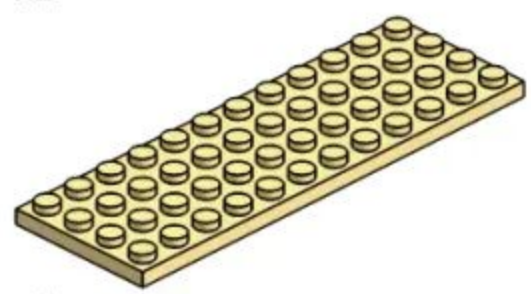
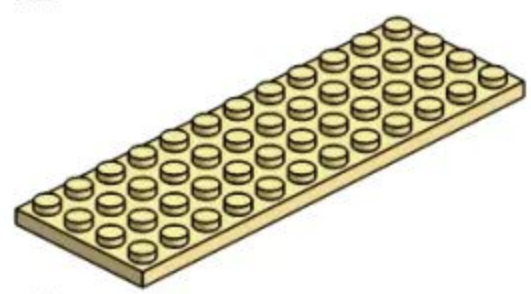
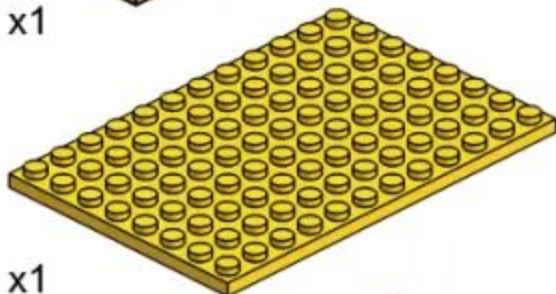
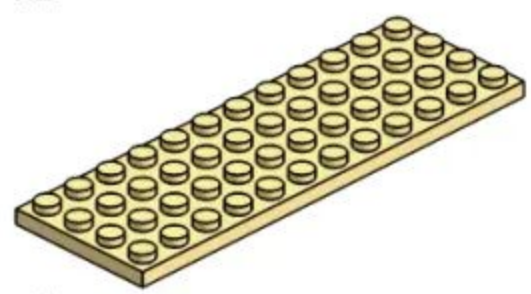
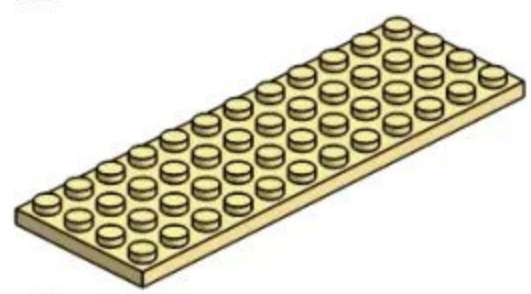
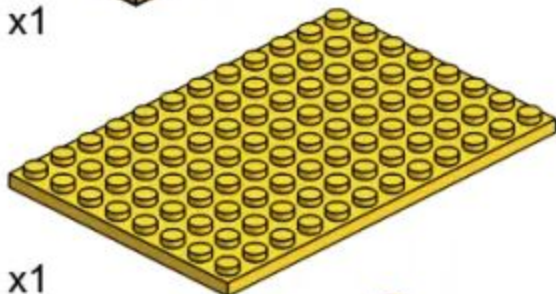
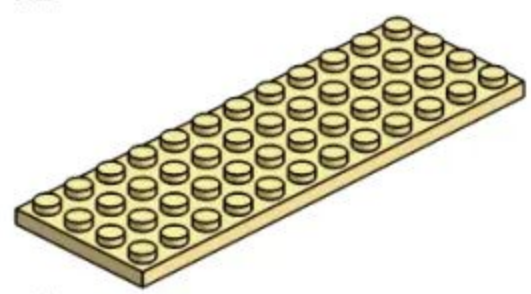
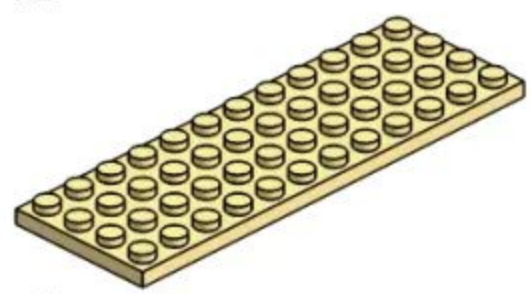
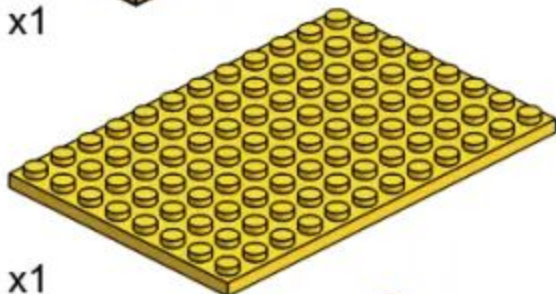
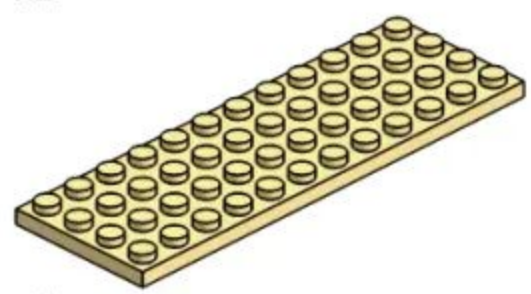
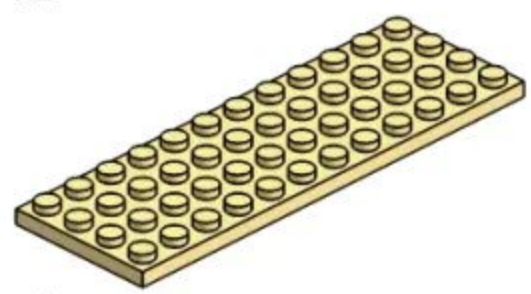
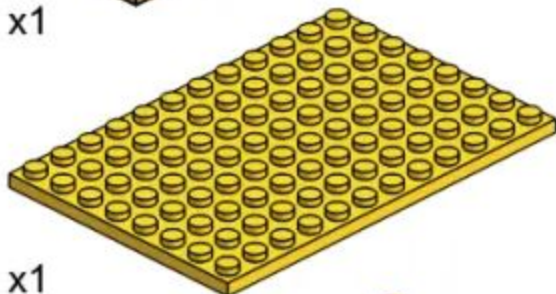
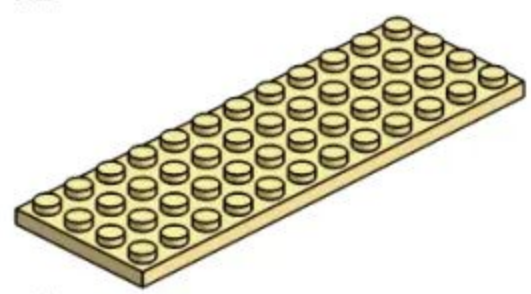
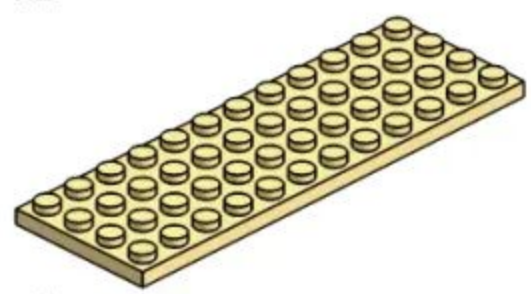
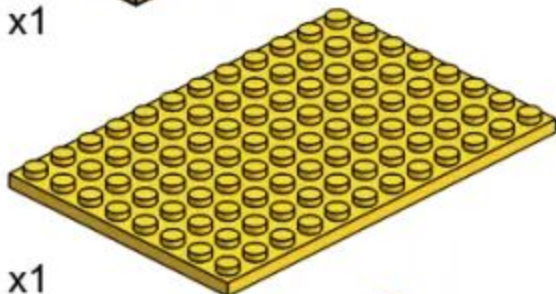
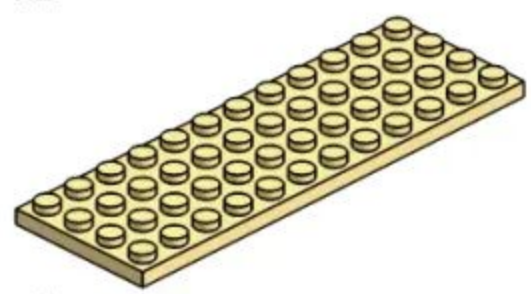
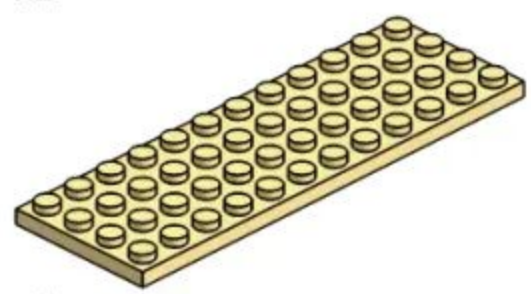
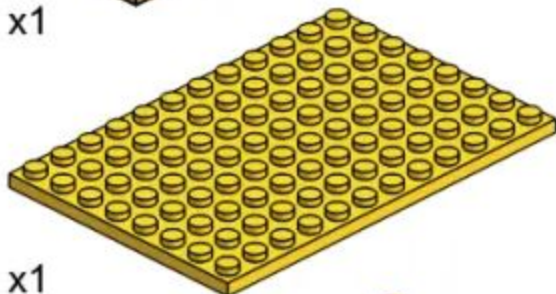
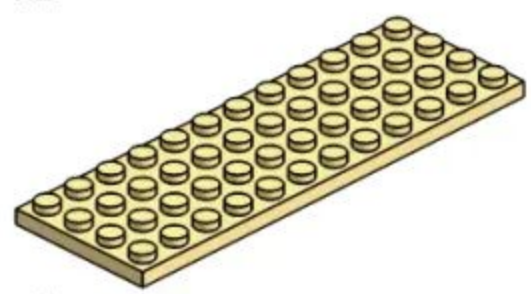
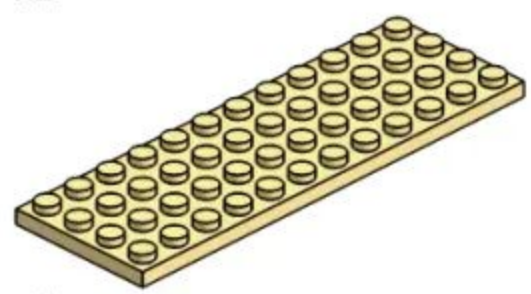
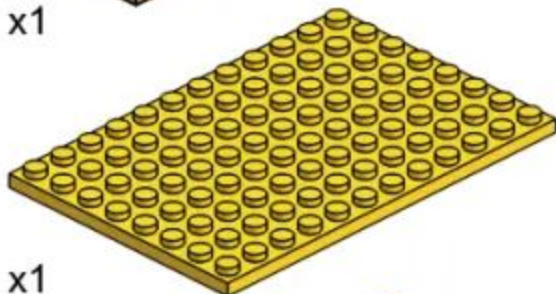
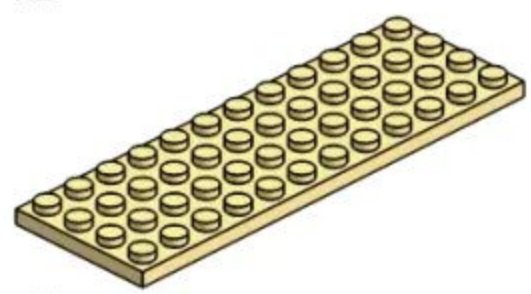
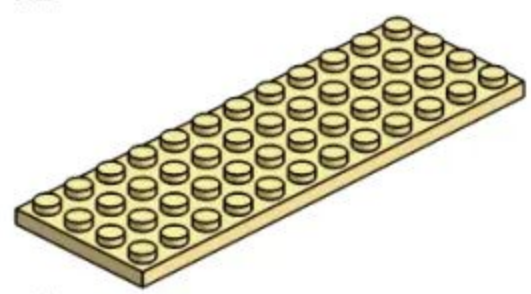
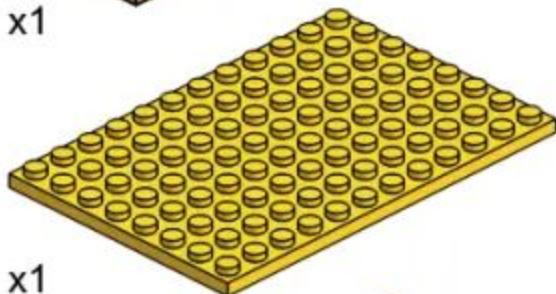
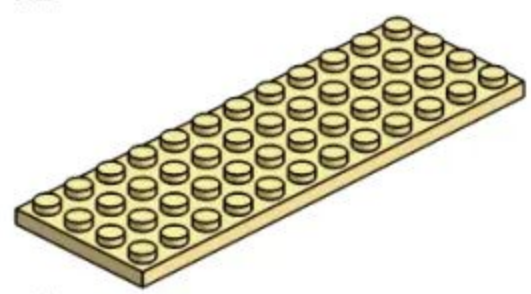
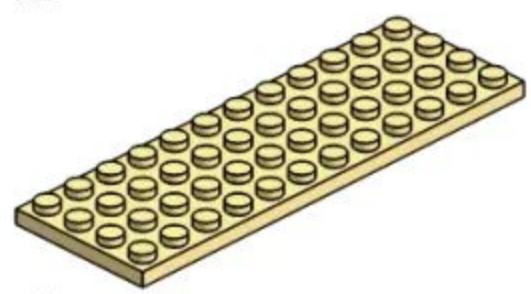
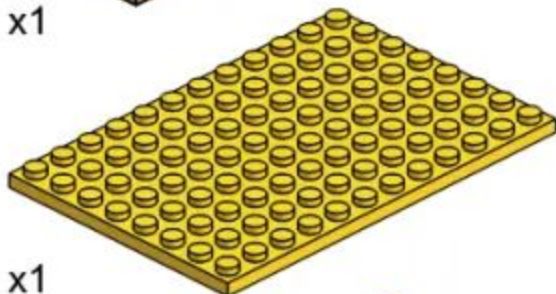
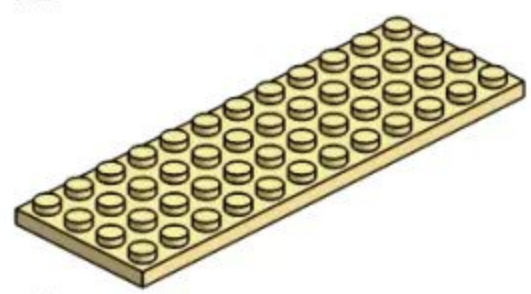
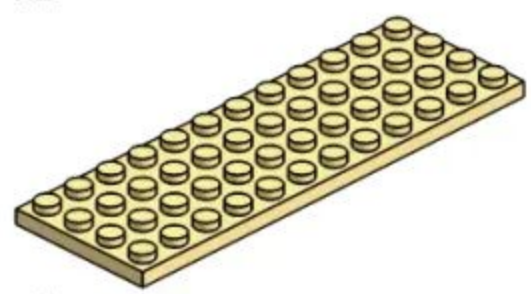
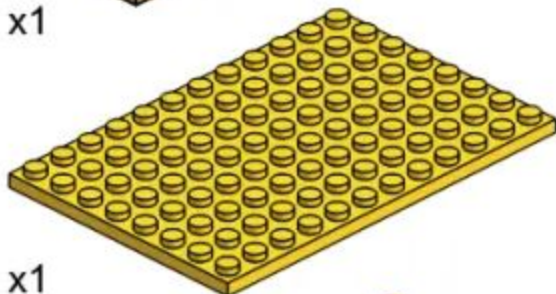
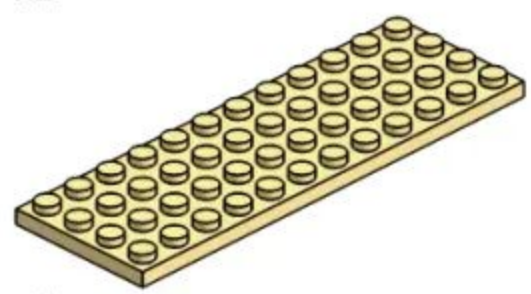
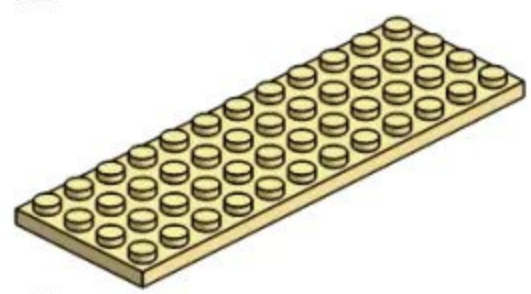
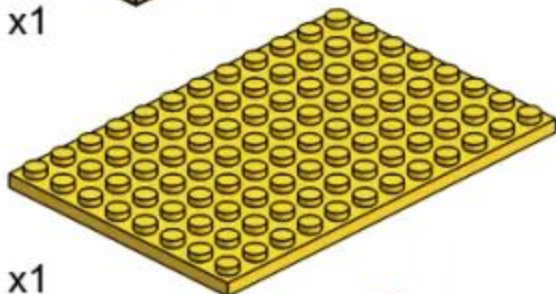
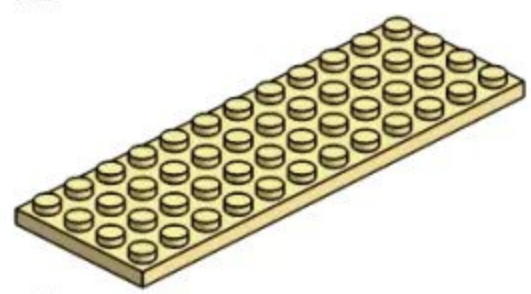
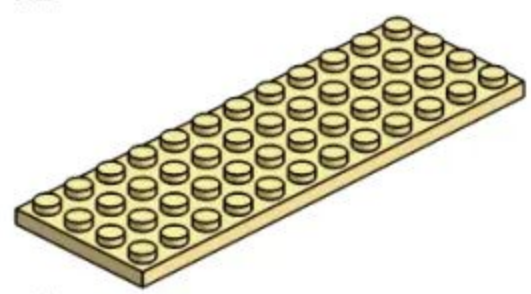
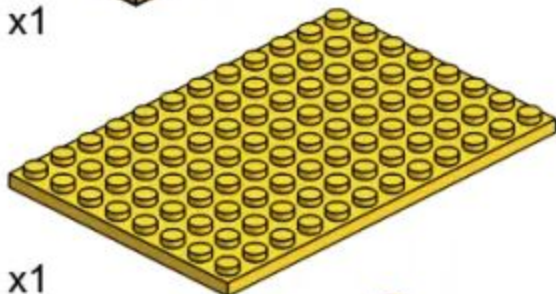
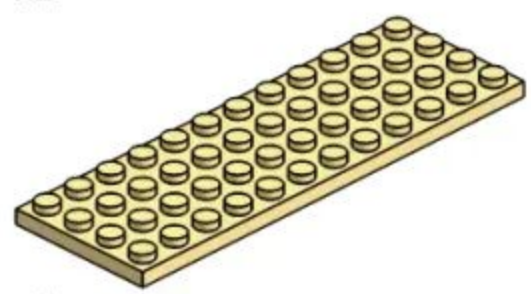
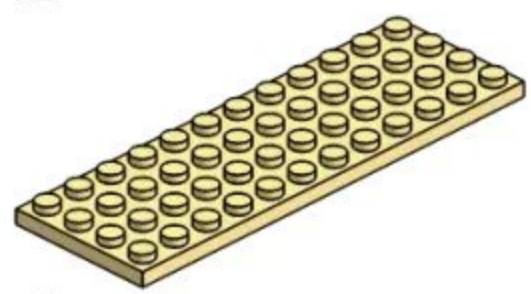
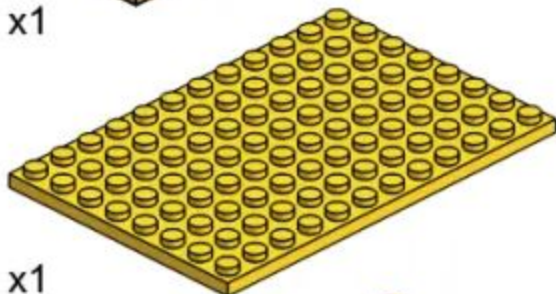
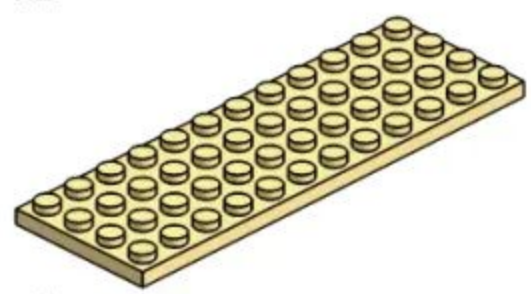
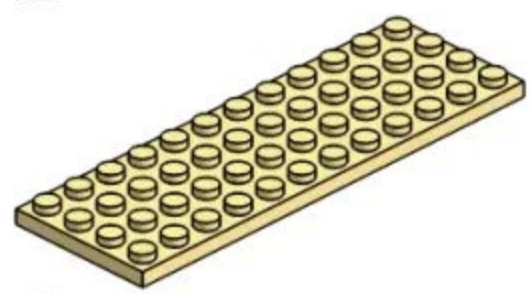
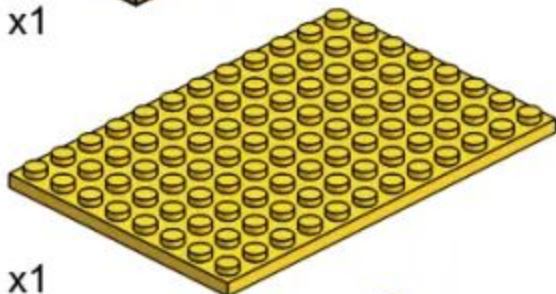
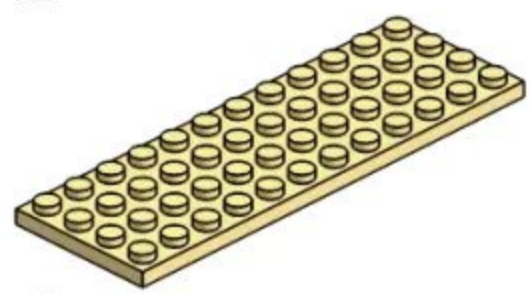
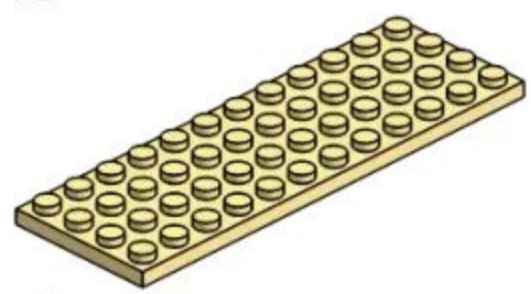
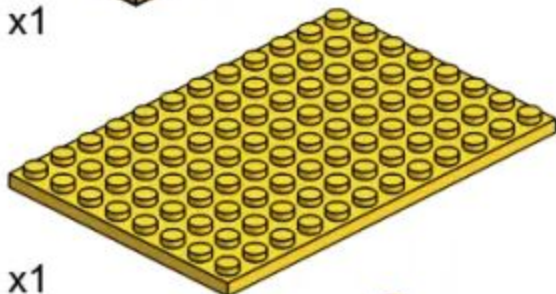
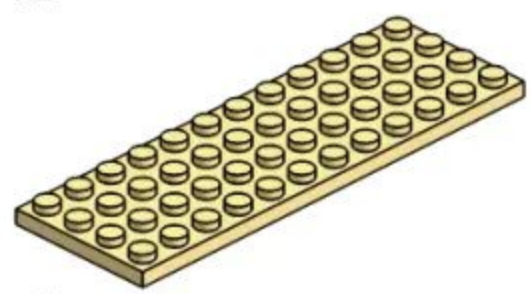
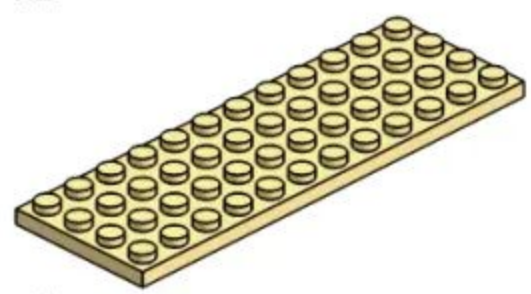
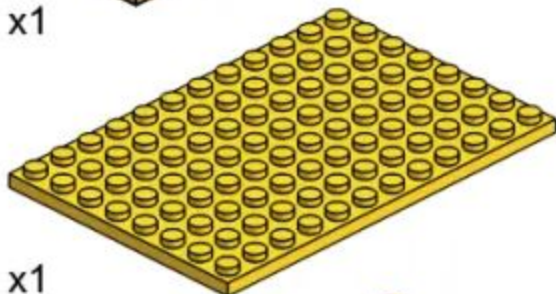
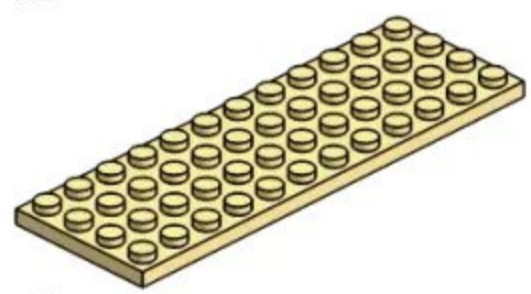
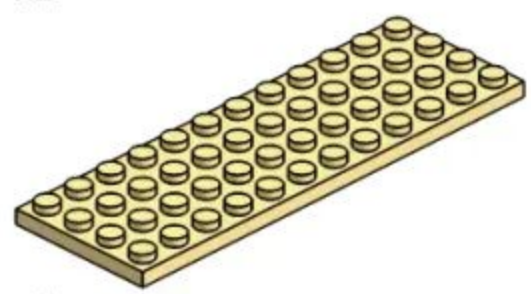
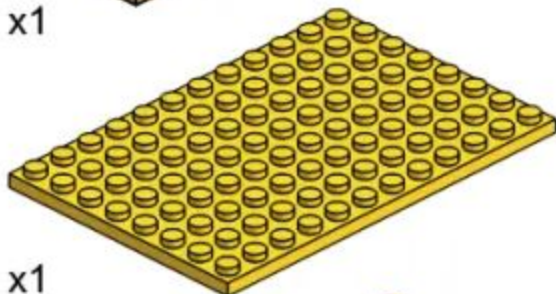
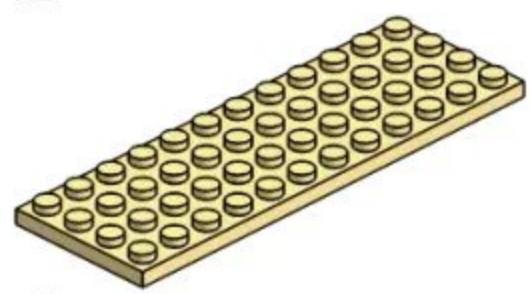
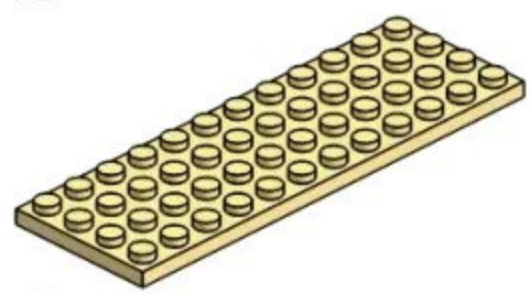
	x4			
	x6		x4	x5
x2				
	x19	x6	x8	x2
x2				
	x4	x2	x4	x1
x2				
	x3	x4	x4	x8
x2				
	x4		x2	x2
x2				
	x12		x4	
x4				
	x4	x1		
x18			x4	
	x12	x1		
x4				
	x4			
x8				
	x12			
x8				
	x4			
x4				
	x6			
				
				
				
				
				
				
				
				
				
				
				
				
				
				
				
				
				
				
				
				
				
				
				
				
				
				
				
				
				
				
				
				
				
				
				
				
				
				
				
				
				
				
				
				
				
				
				
				
				
				
				
				
				
				
				
				
				
				
				
				
				
				
				



223PCS

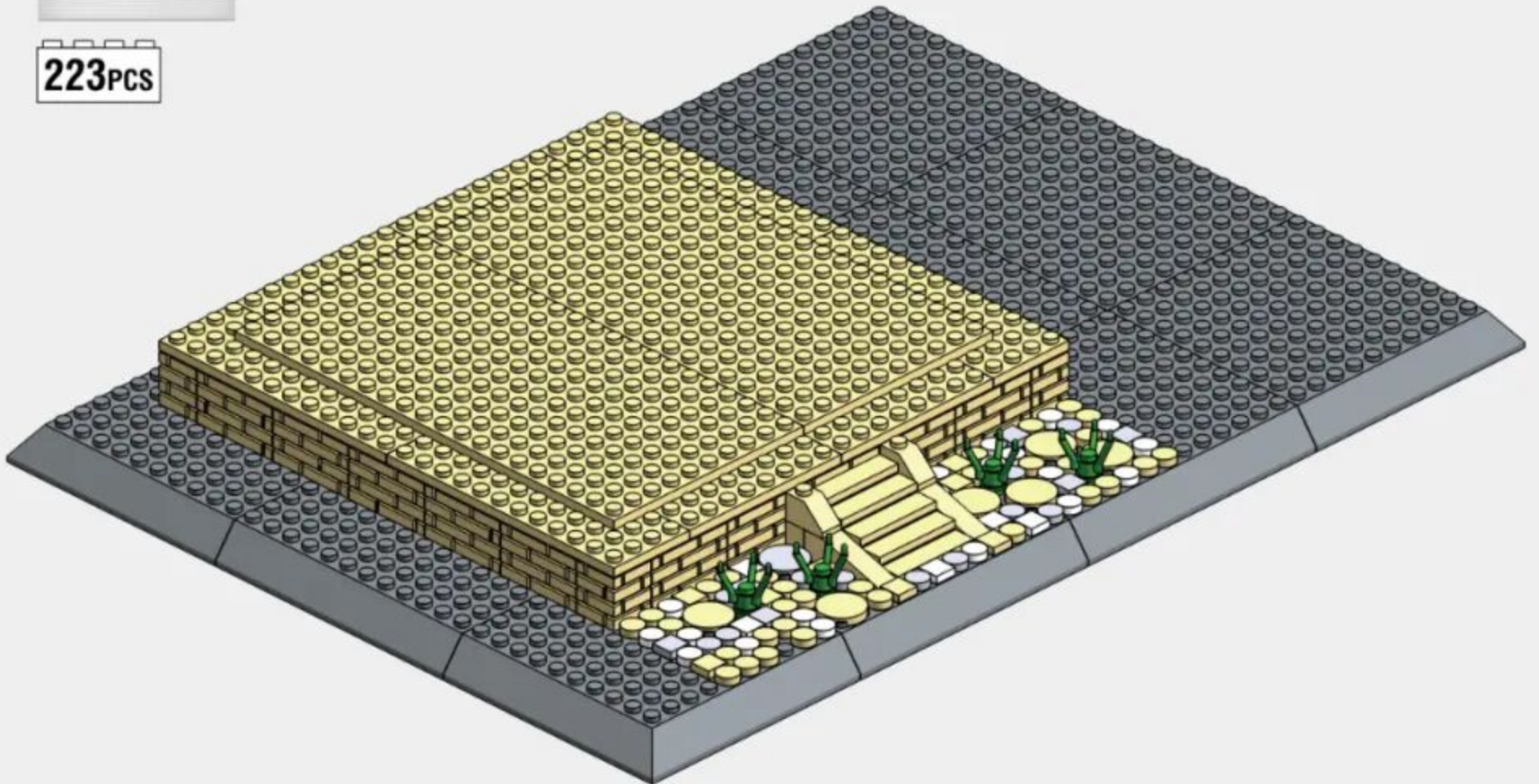

1-1

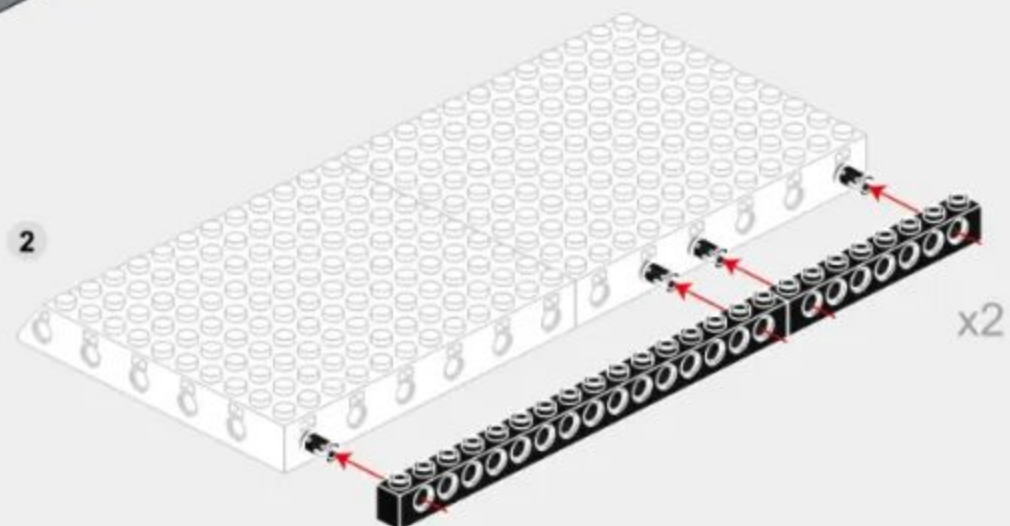
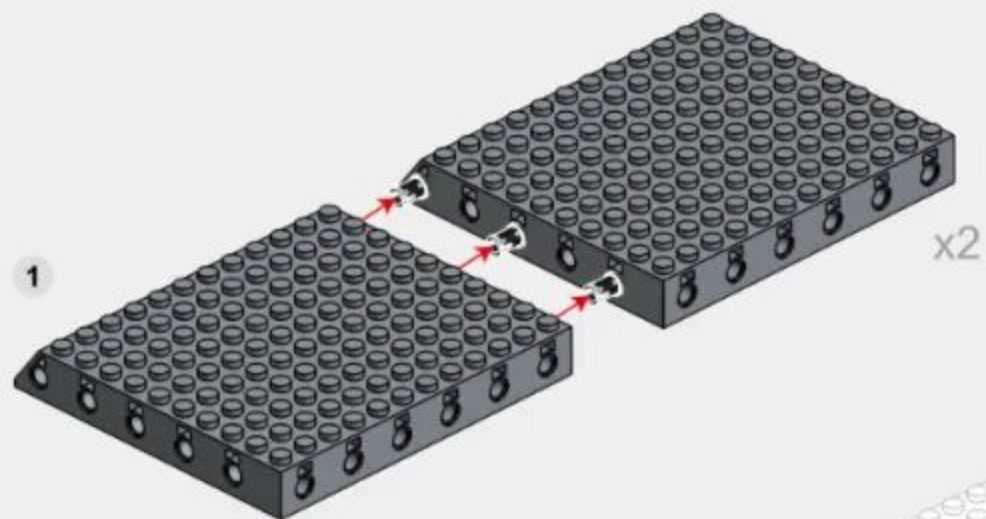
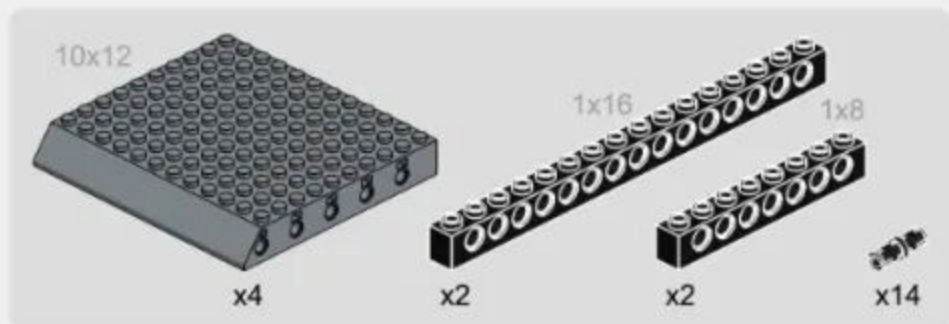

1-2

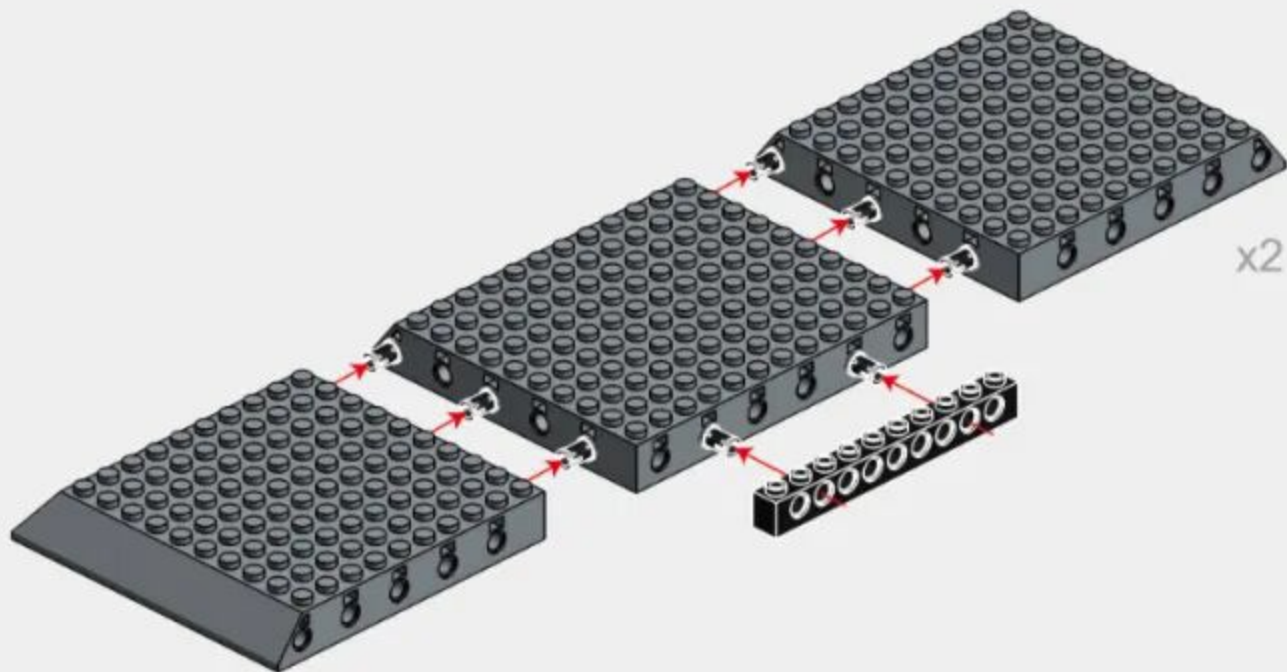
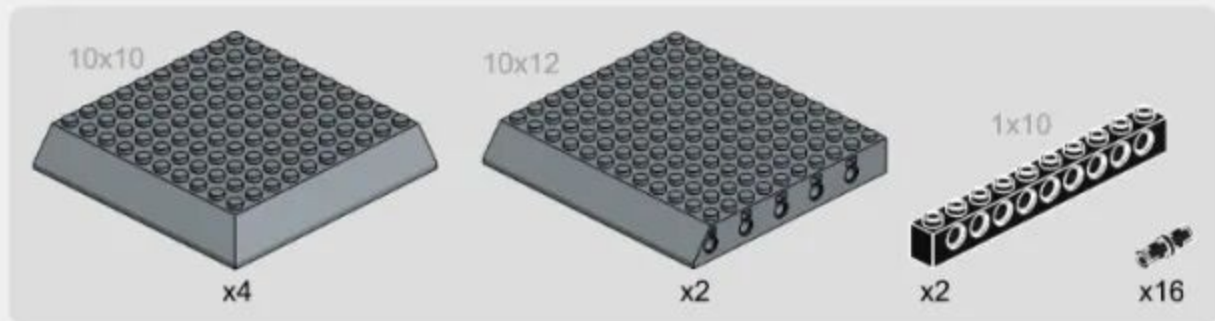

1-3

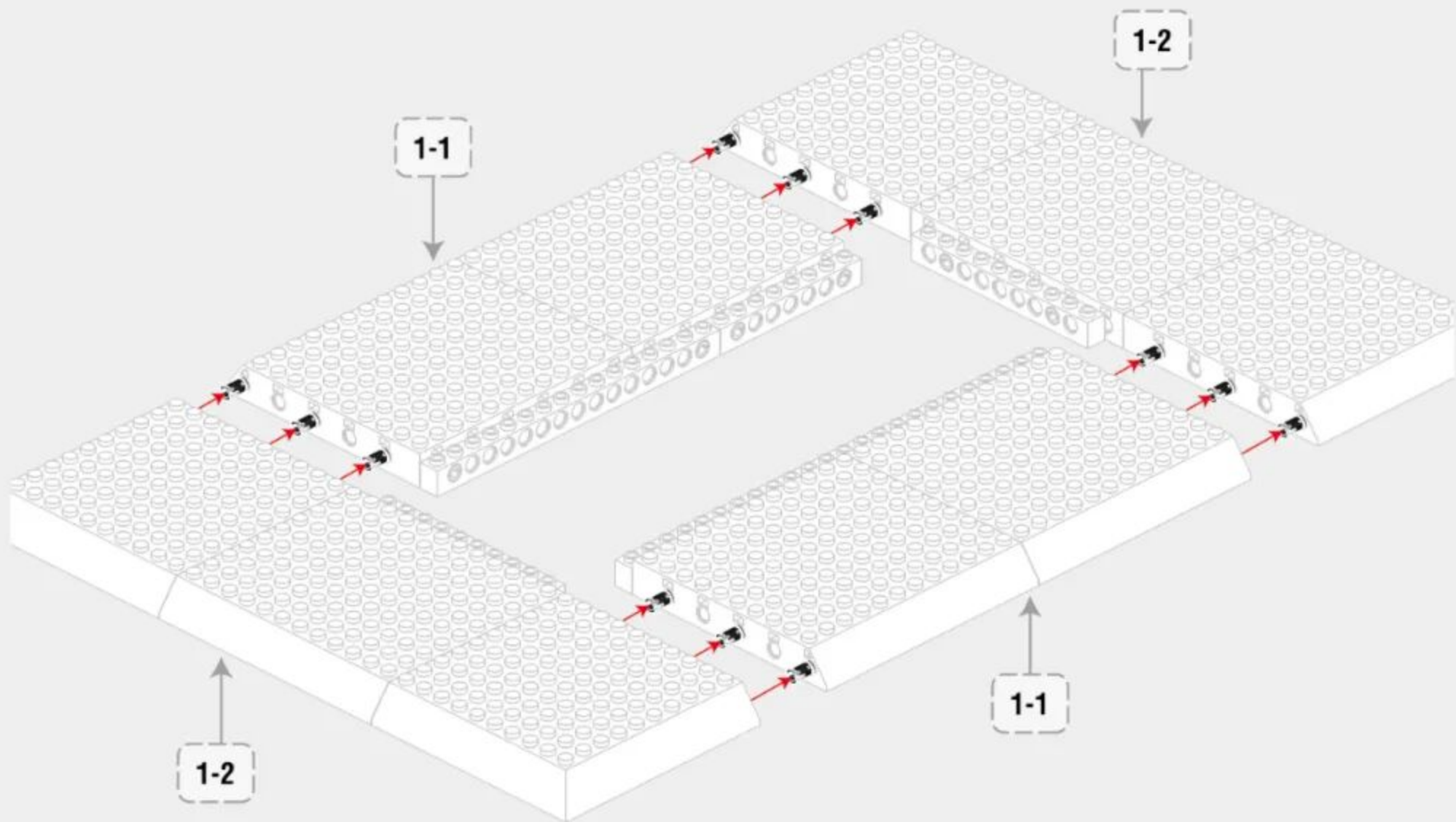

1-4

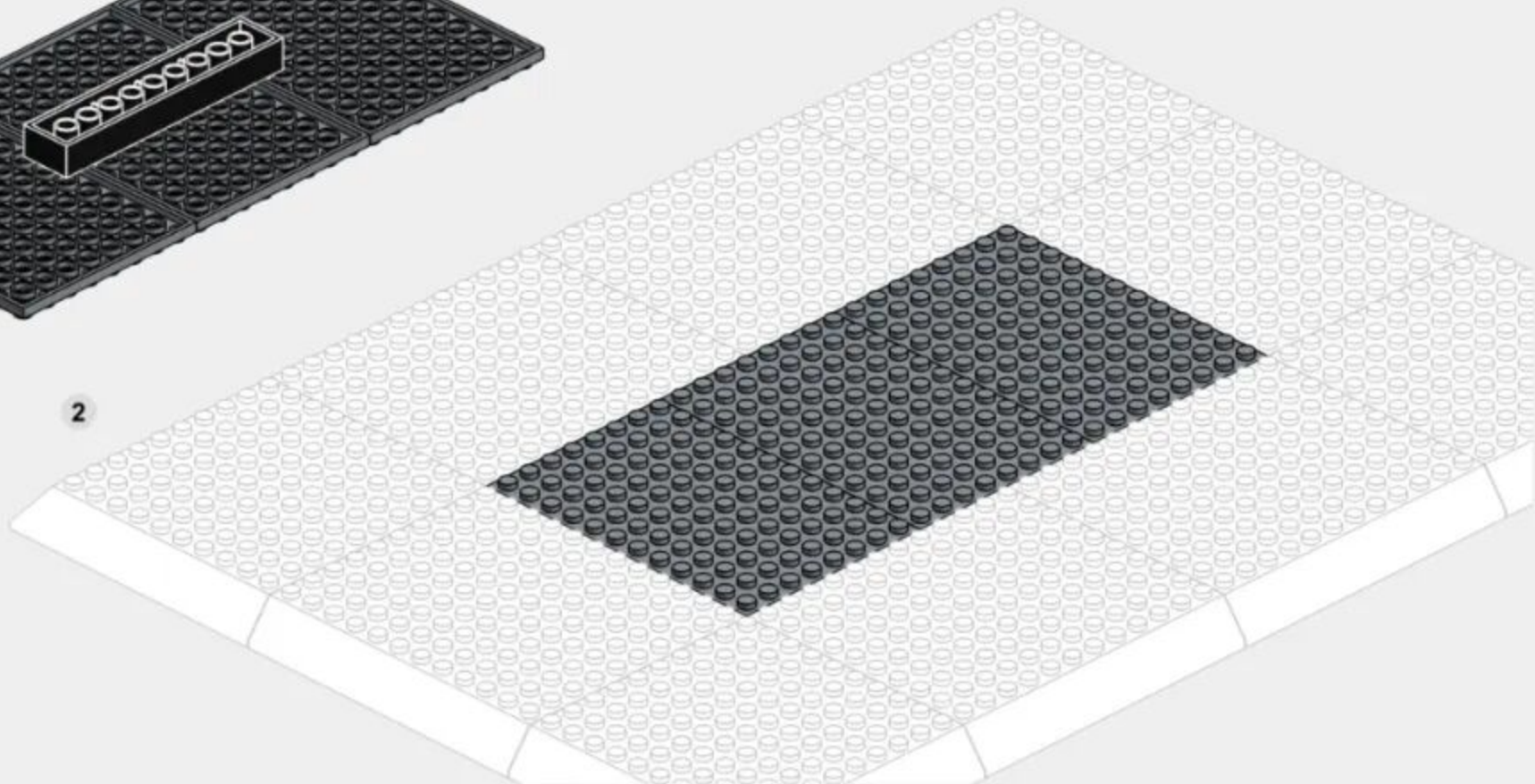
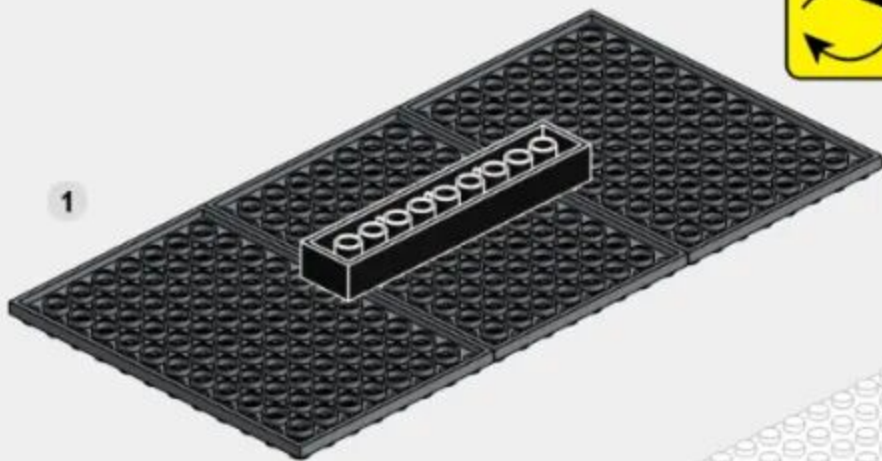
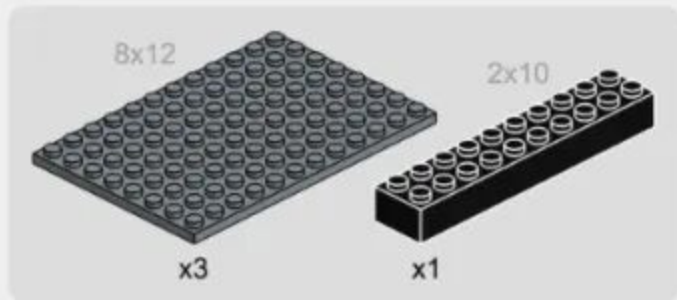

1-5

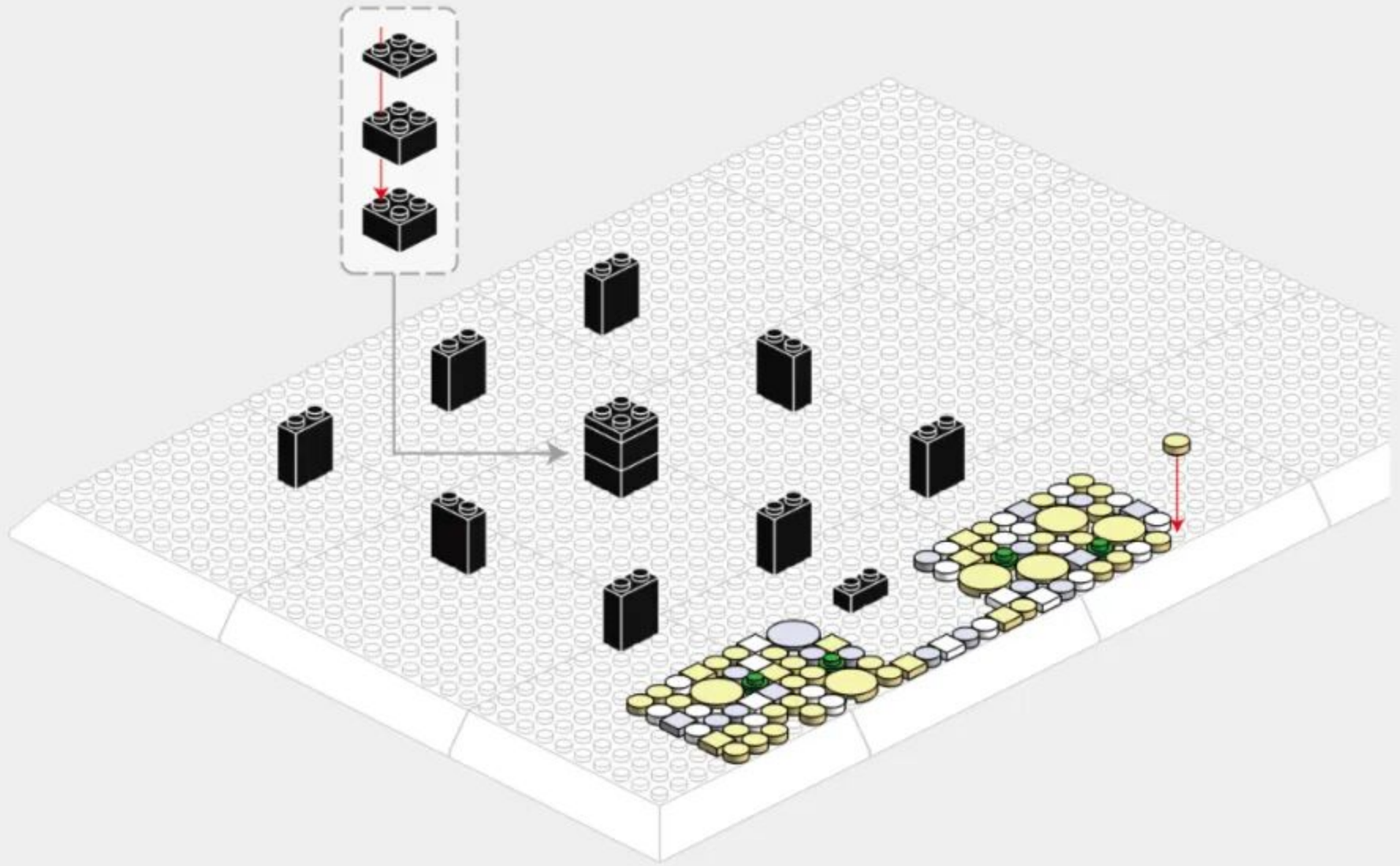
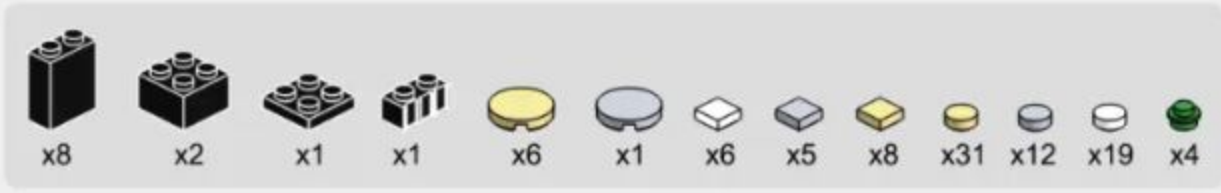

1-6

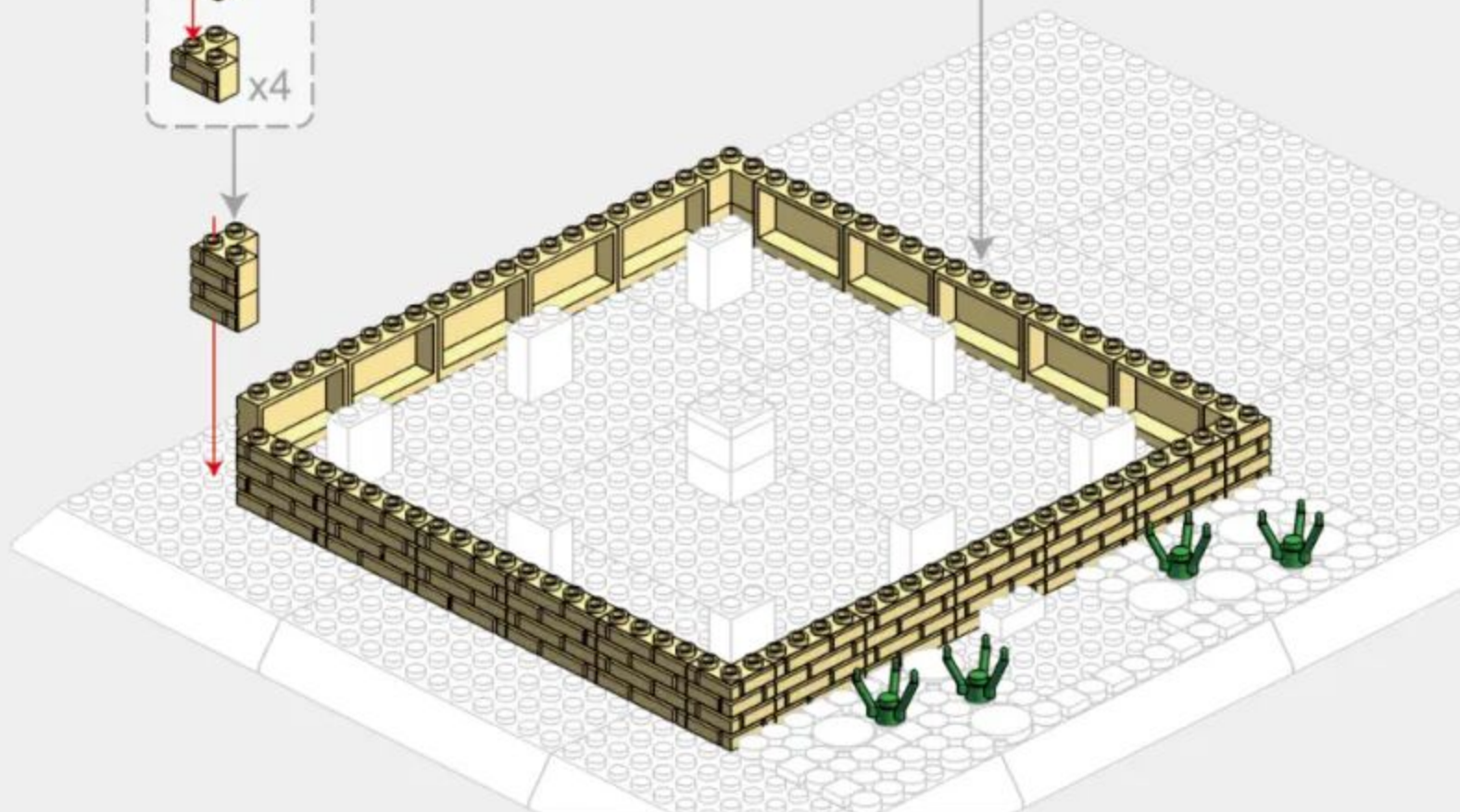
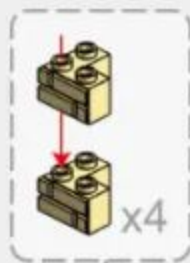
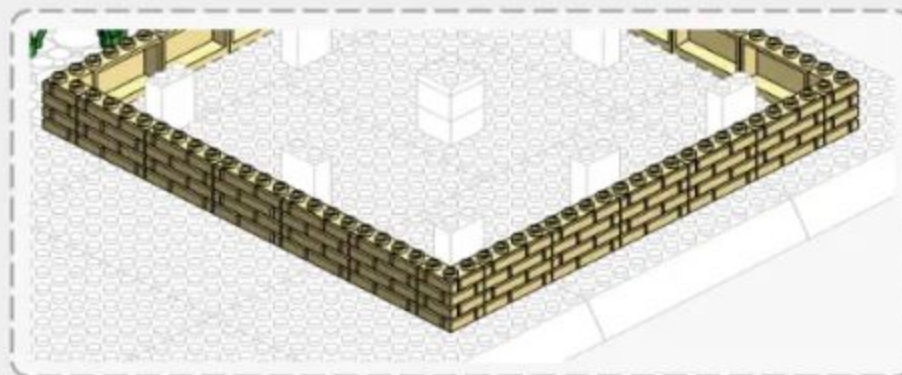

1-7

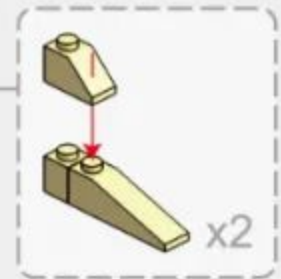
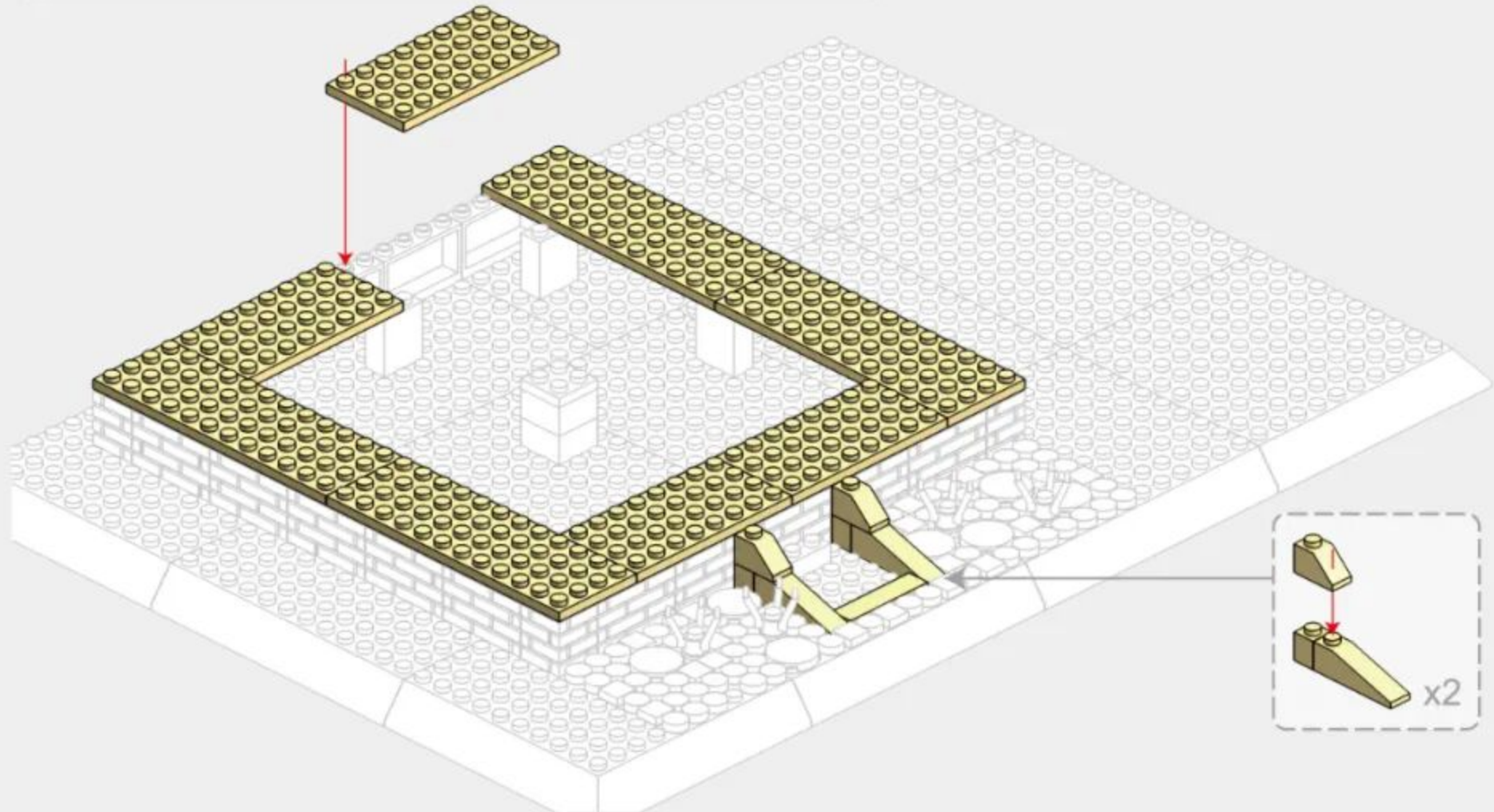
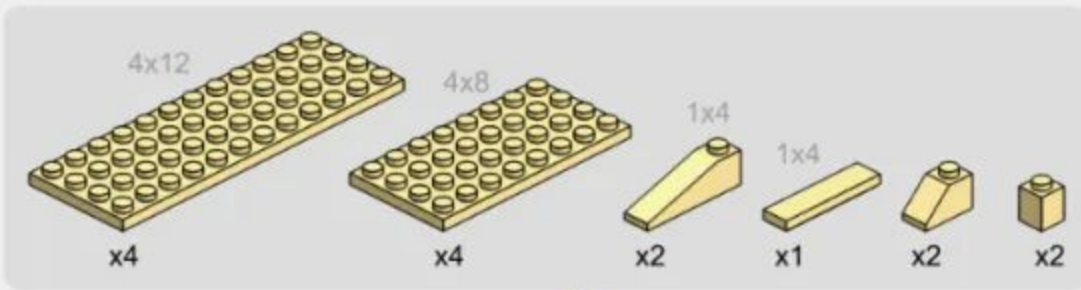





234PCS



2-1

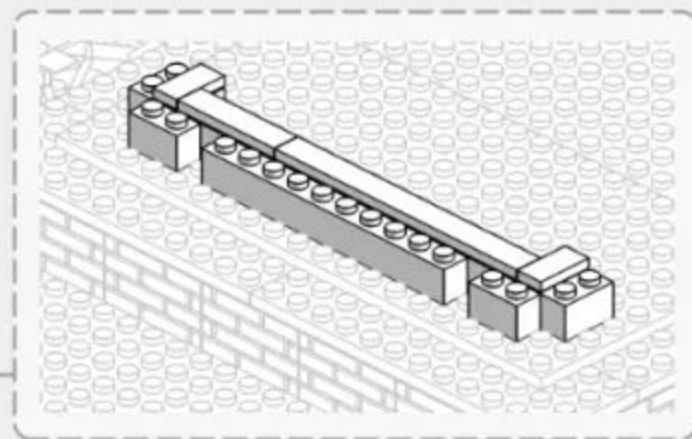
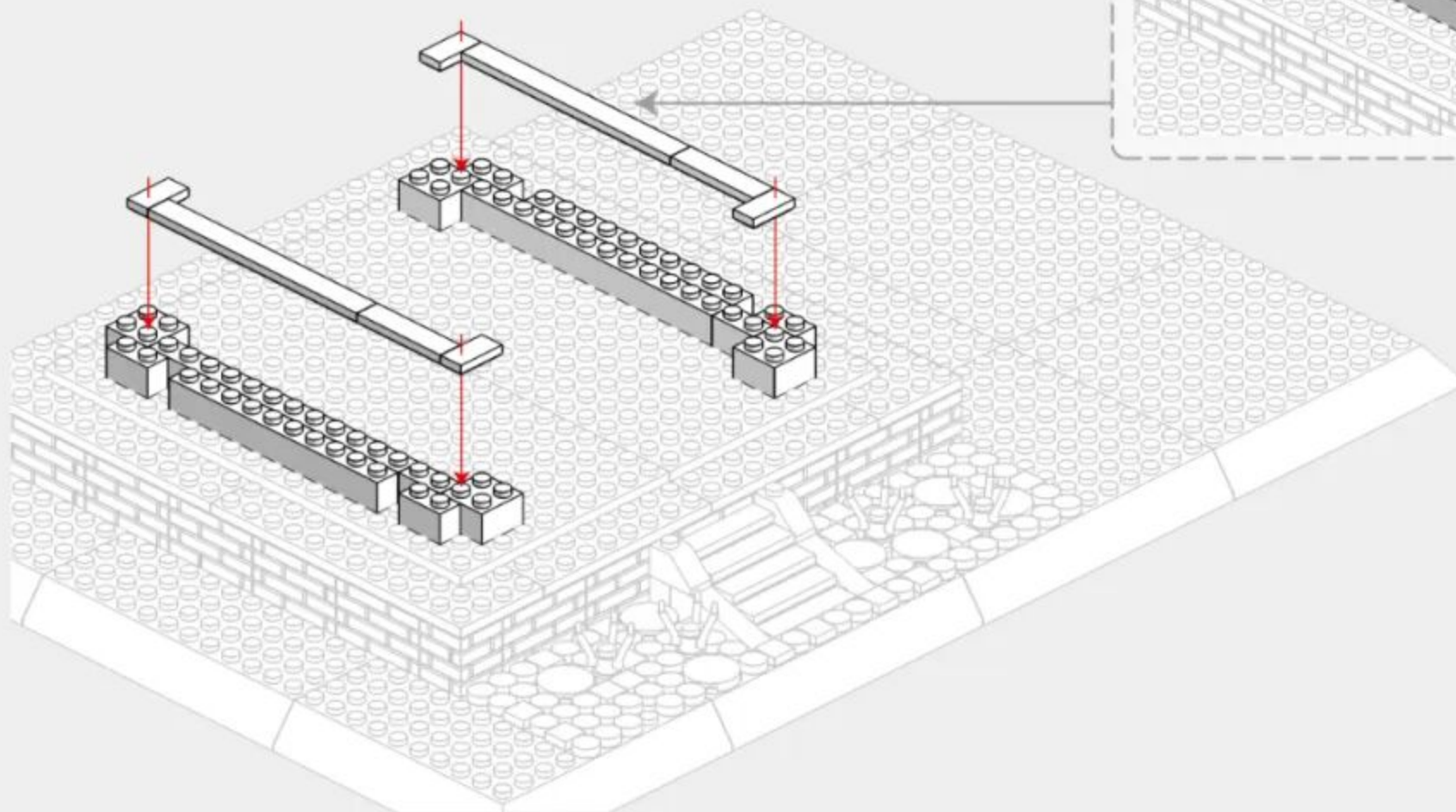
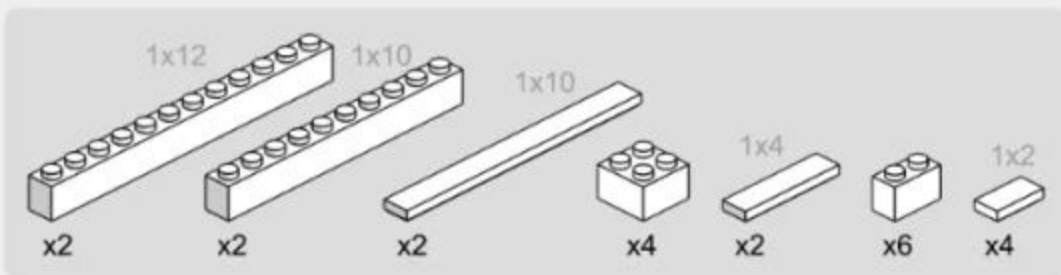

2-2

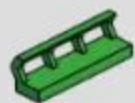

x12



x2



x4



x18



x4

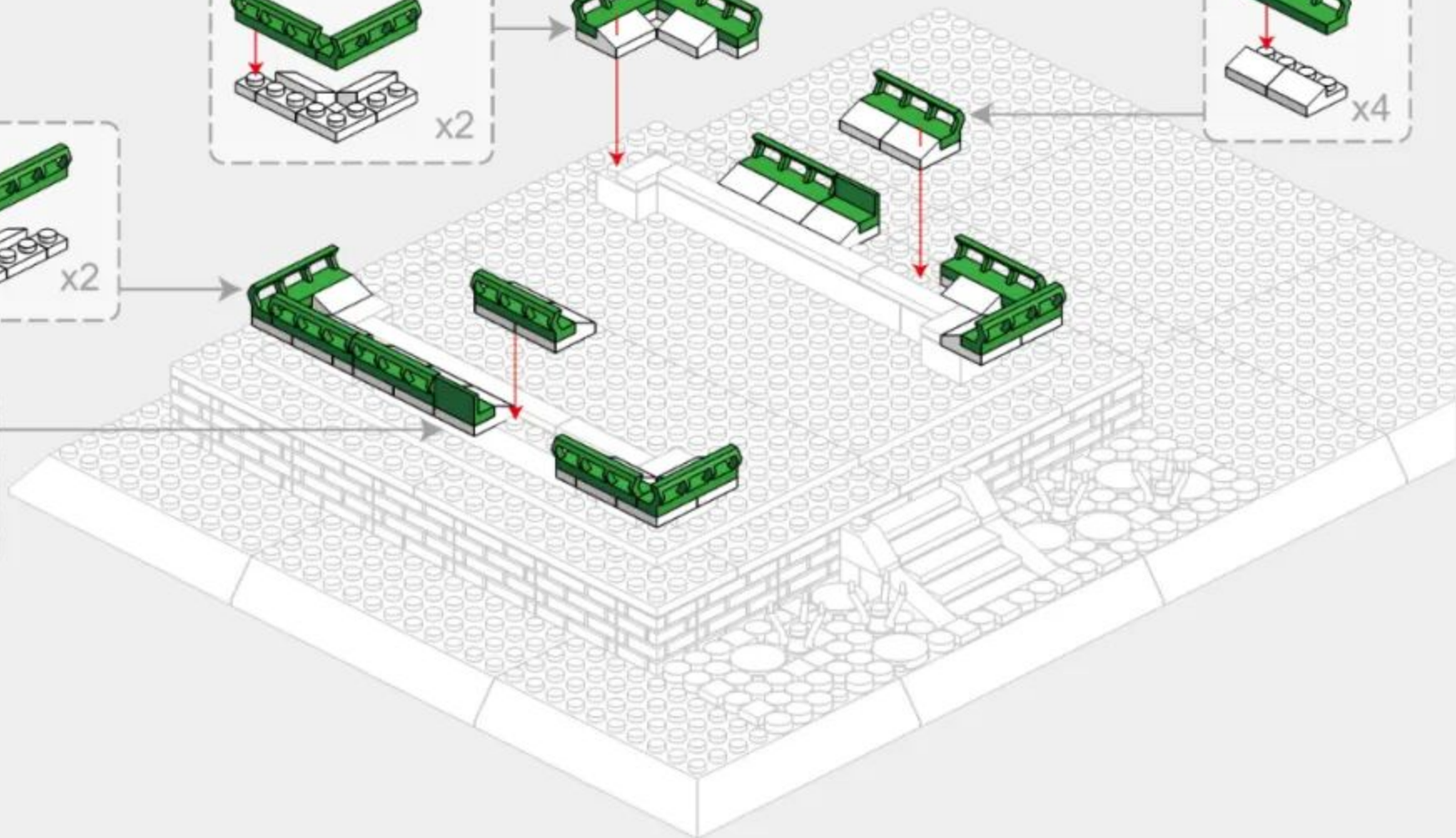
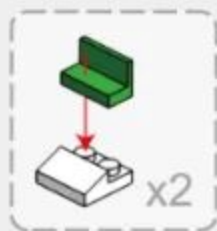
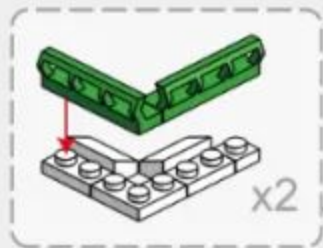
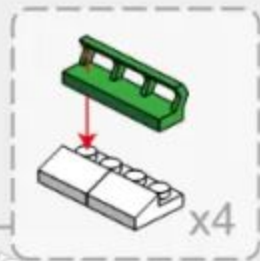
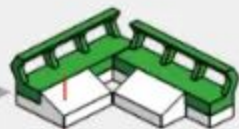
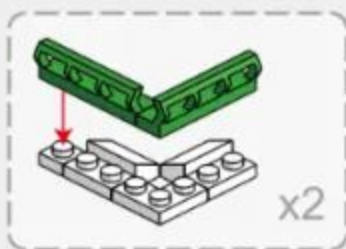

2-3

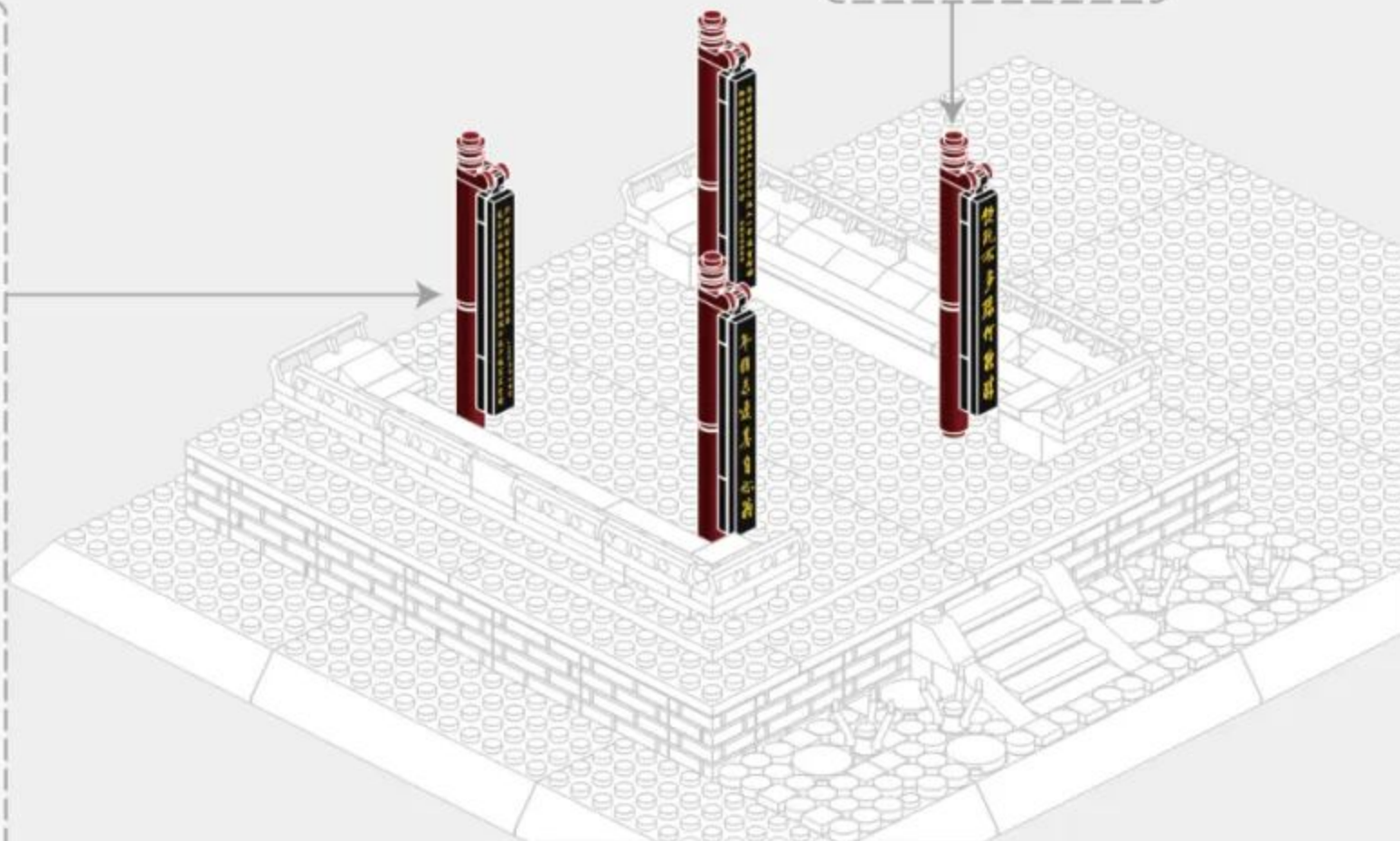
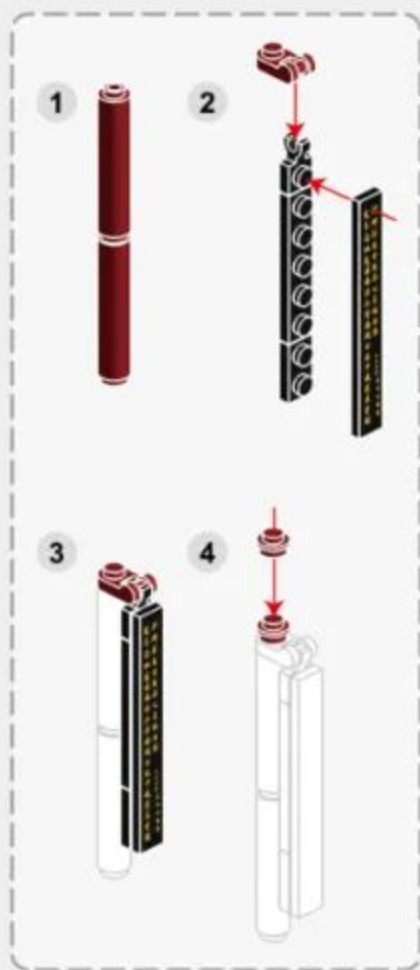
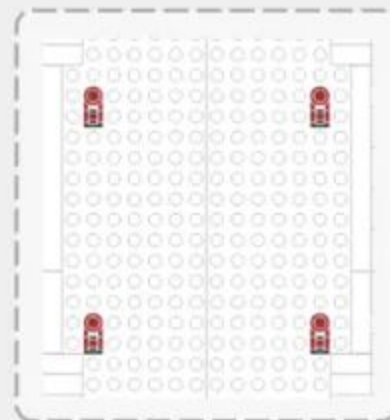



2-5

- 1x5 (red Technic pin) x2
- 1x5 (red Technic pin) x6
- 1x4 (red Technic pin) x4
- 1x4 (red Technic arch) x1
- 1x3 (red Technic pin) x2
- 1x2 (red Technic hole) x2
- 1x2 (red Technic pin) x2
- Grey Technic hook x2
- 1x4 (red Technic Technic pin) x1
- 1x4 (red Technic Technic pin) x1
- Red Technic Technic pin x2
- Red Technic Technic pin x2
- 1x2 (red Technic Technic pin) x2

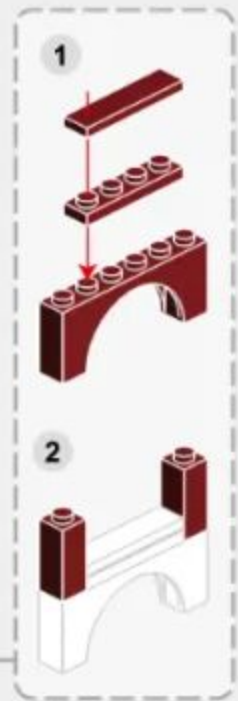
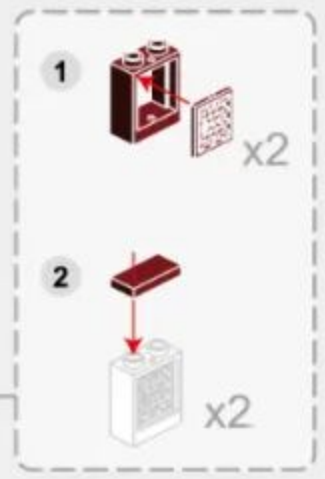
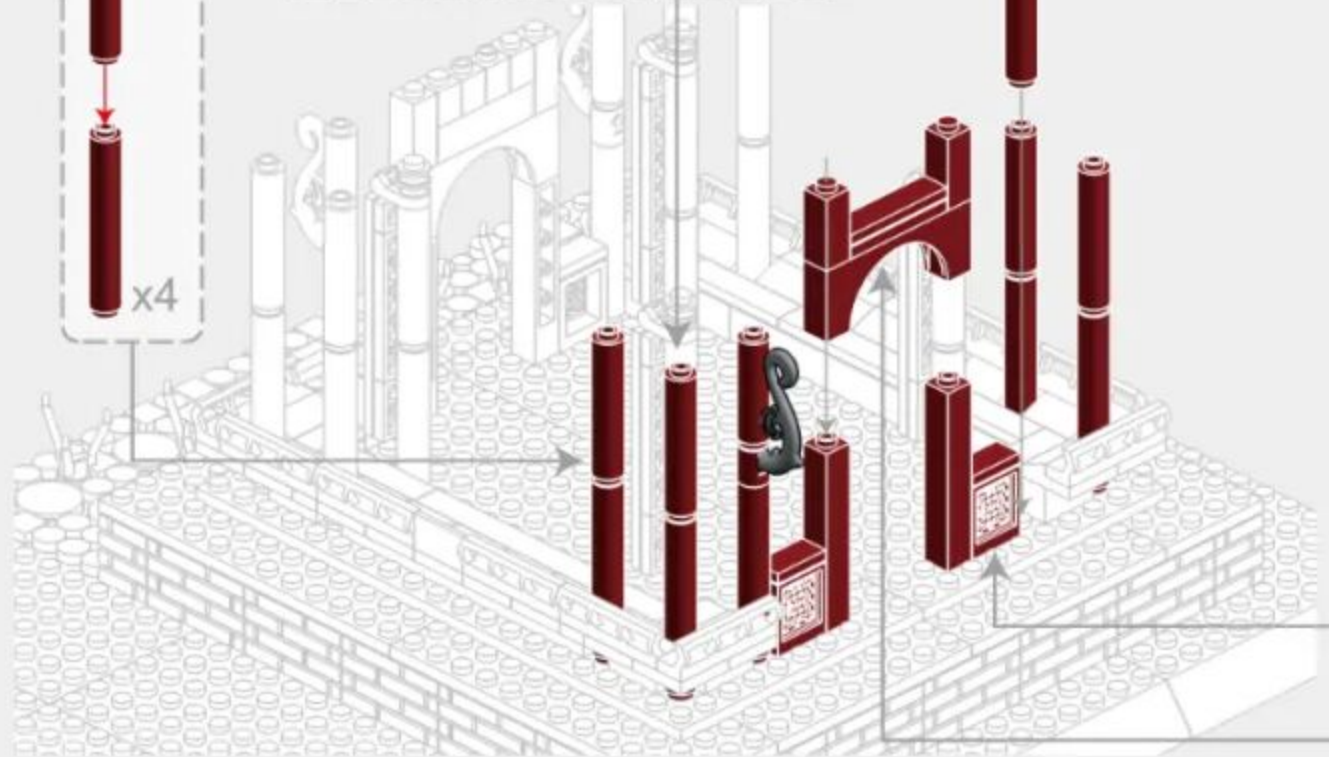
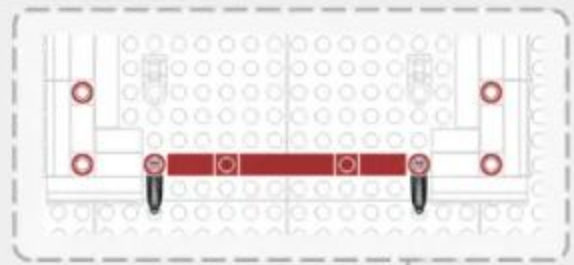

2-6

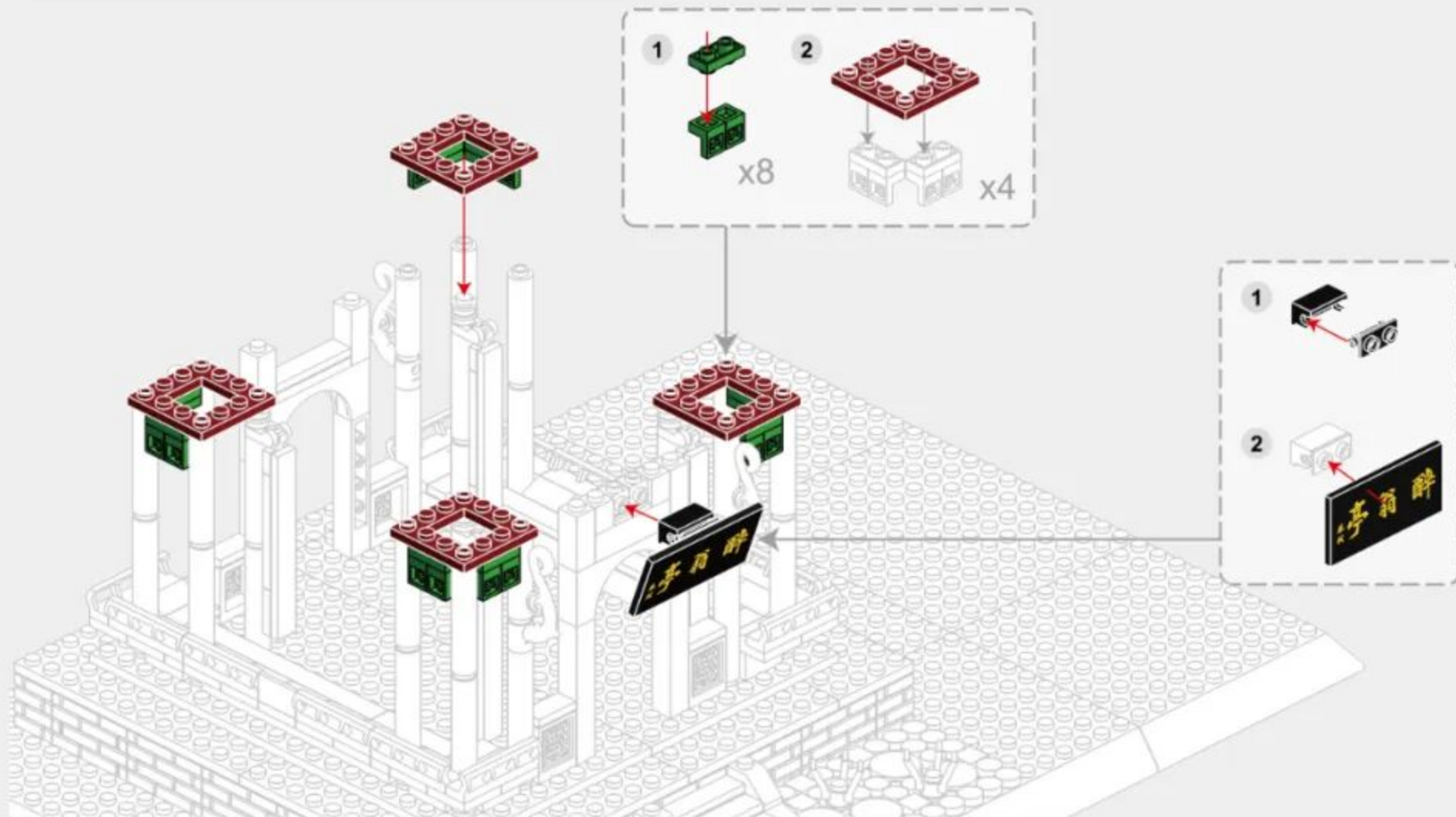
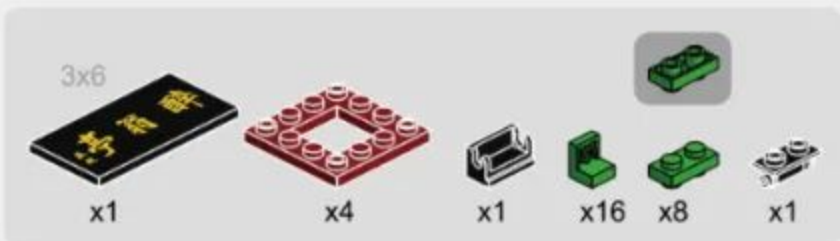

2-7

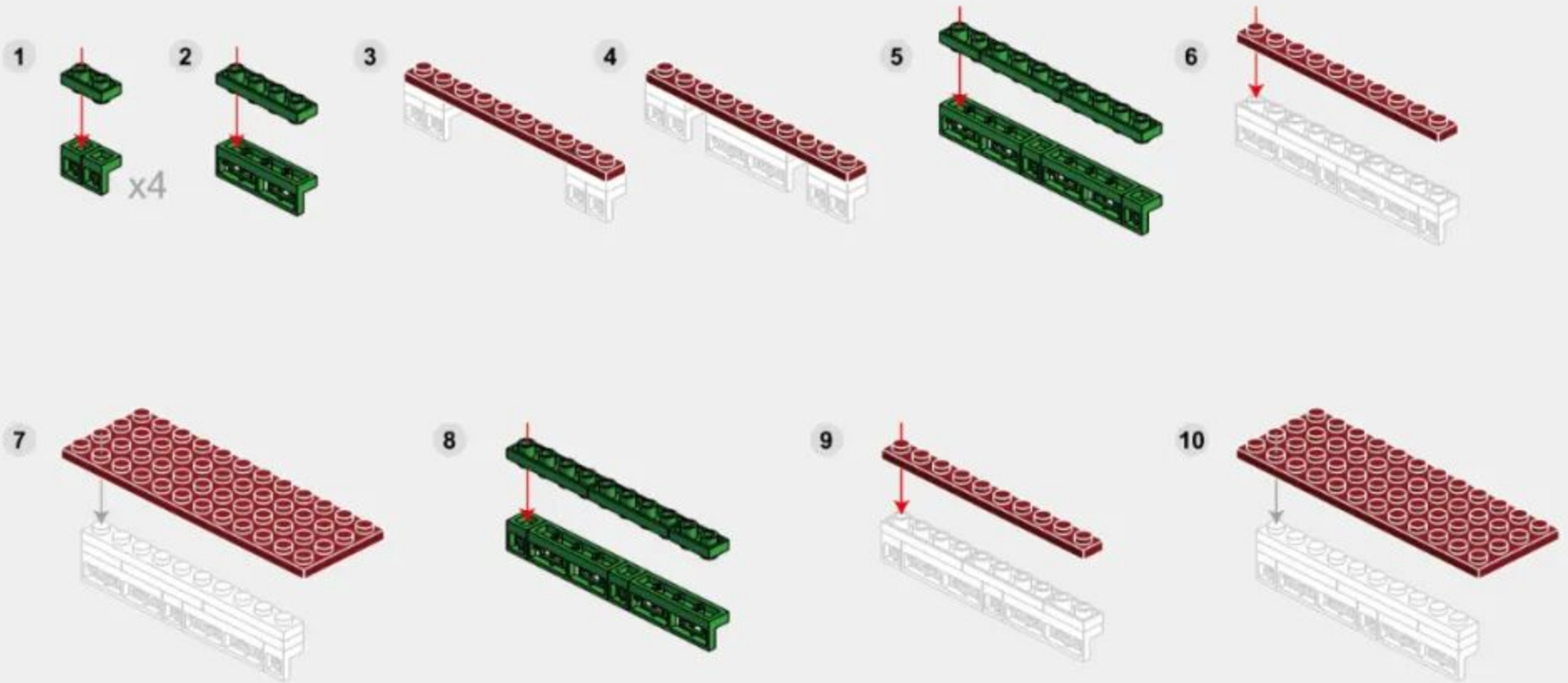
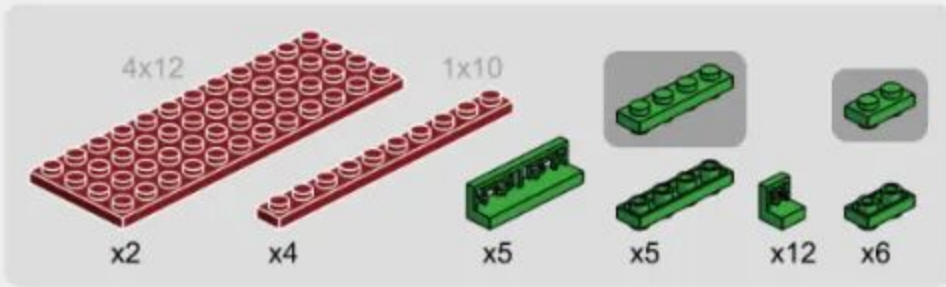

2-8

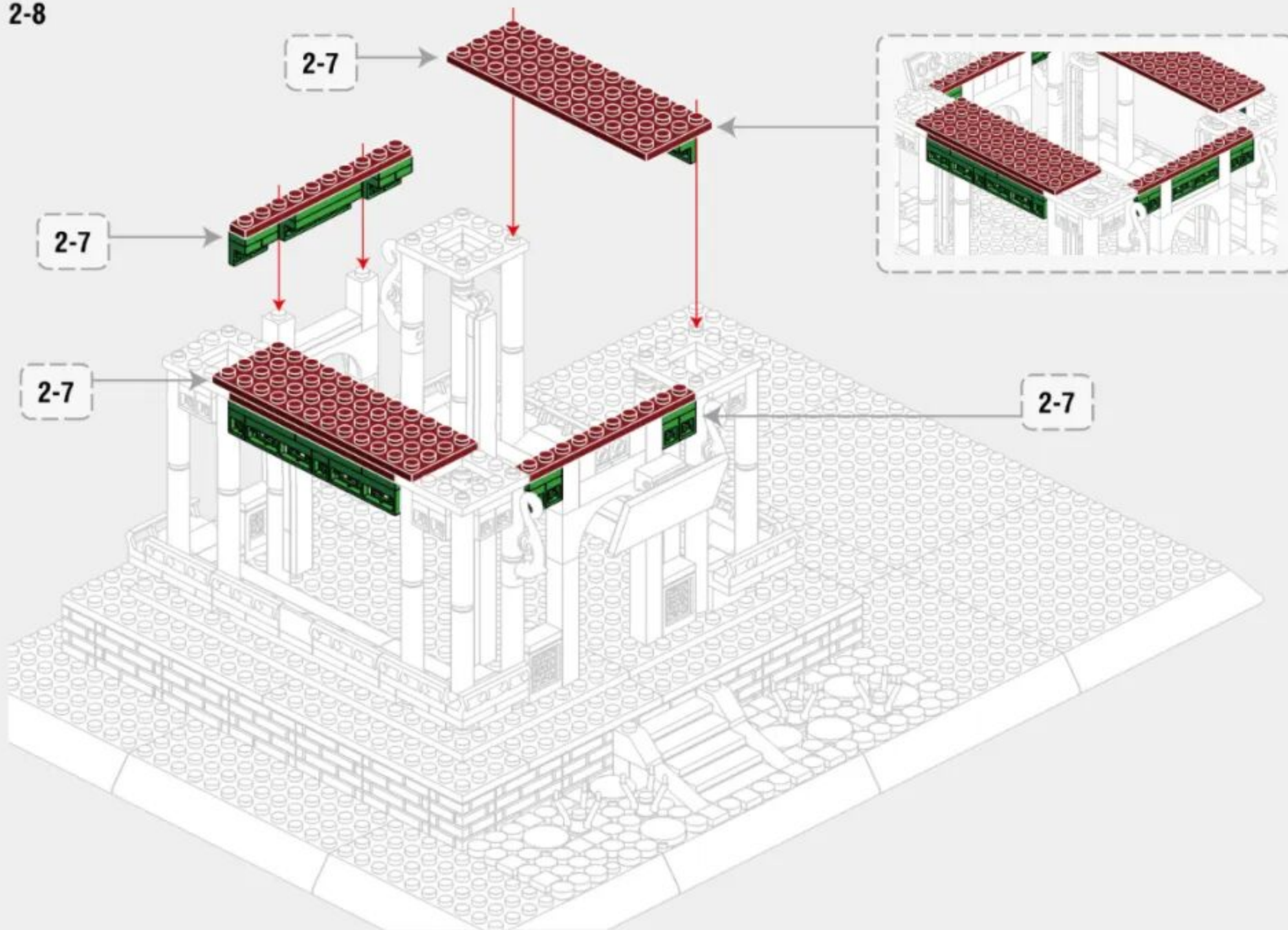

2-9

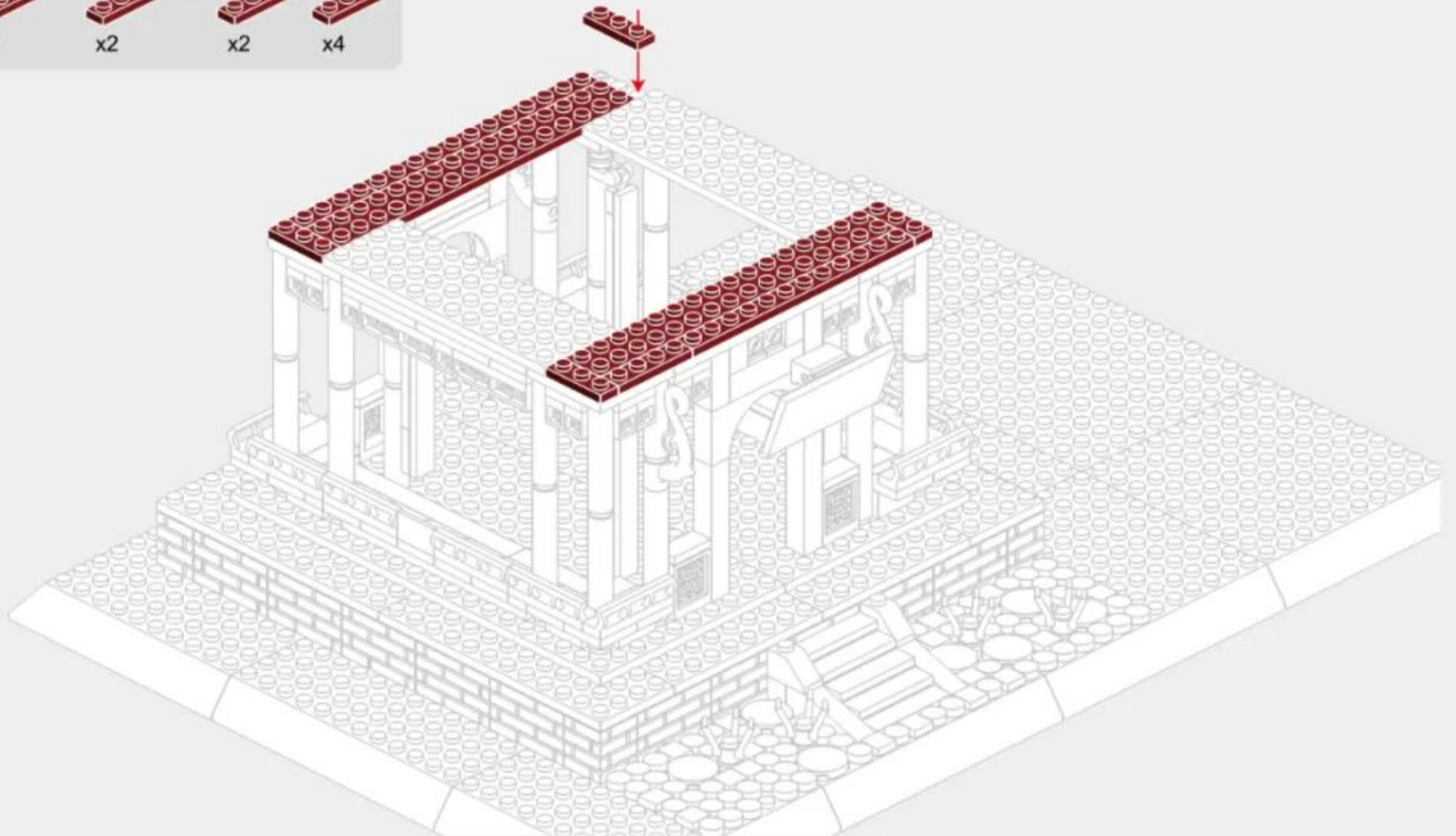
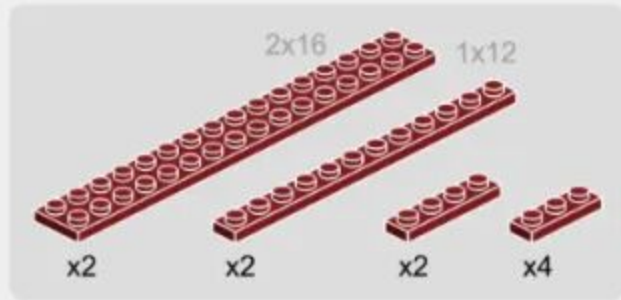

**3**  
**PACK**

**211 PCS**

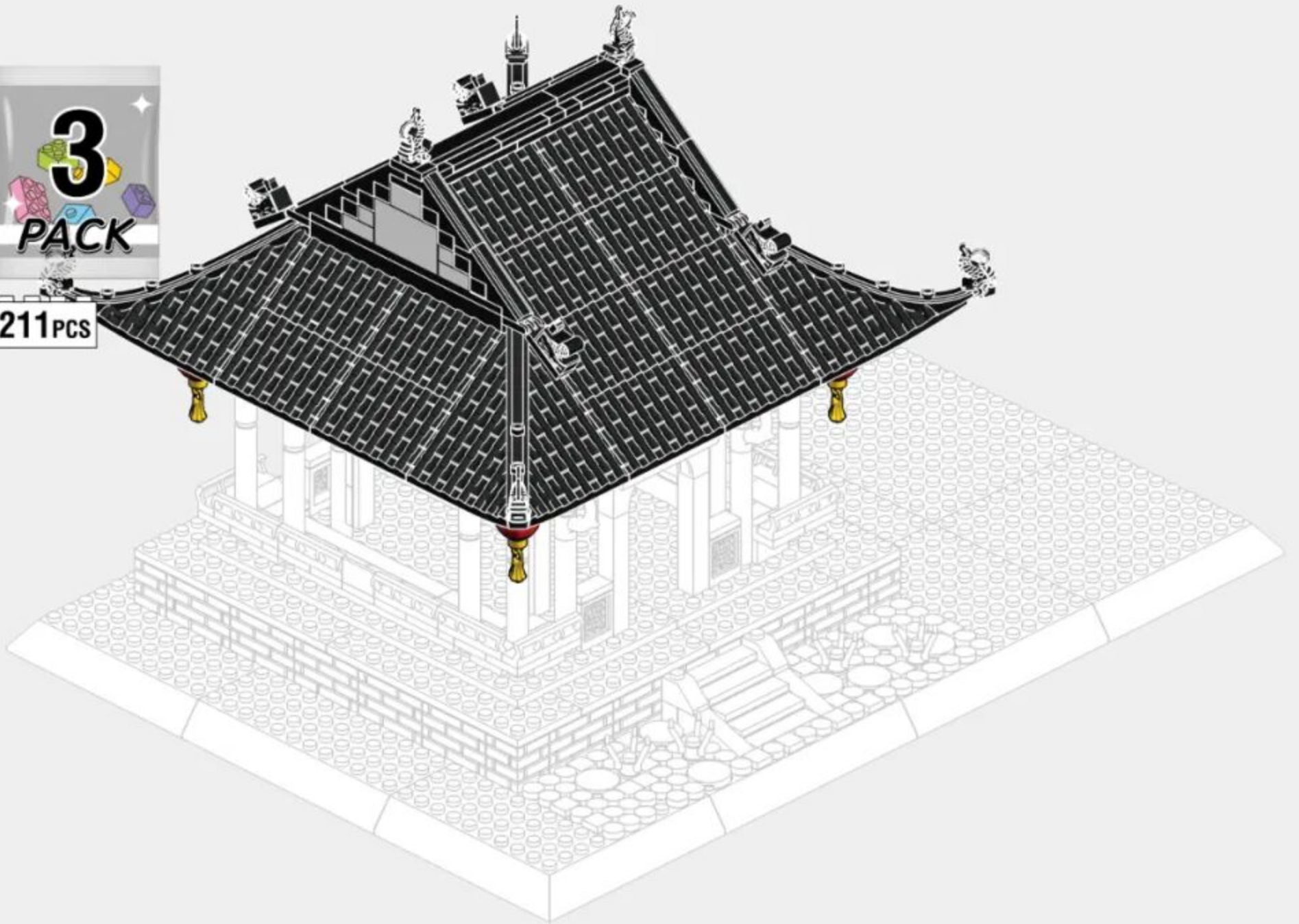

**37**

3-1

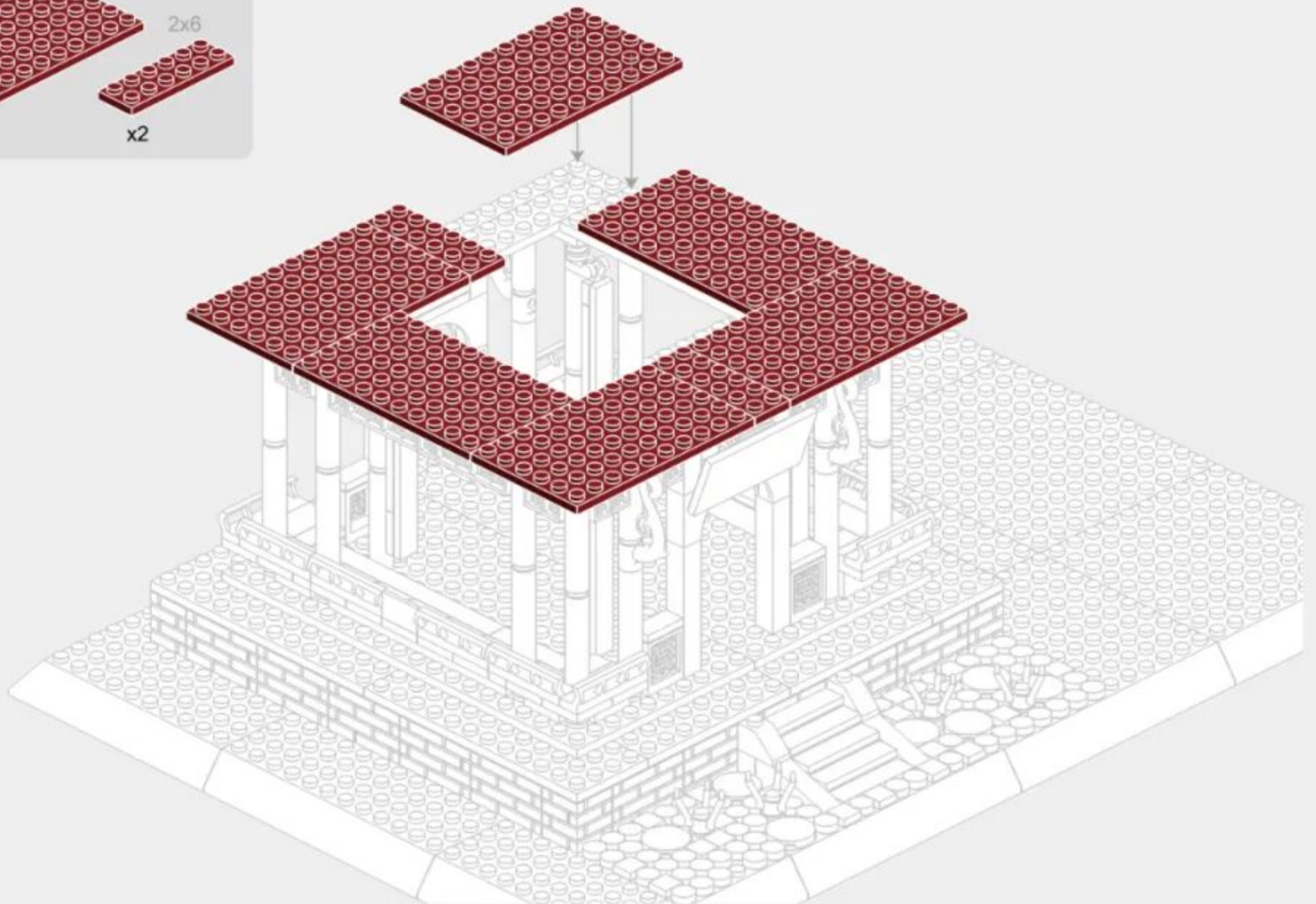
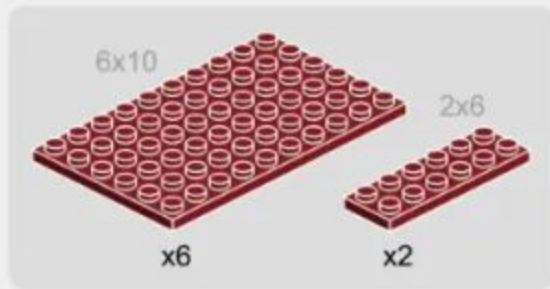

3-2

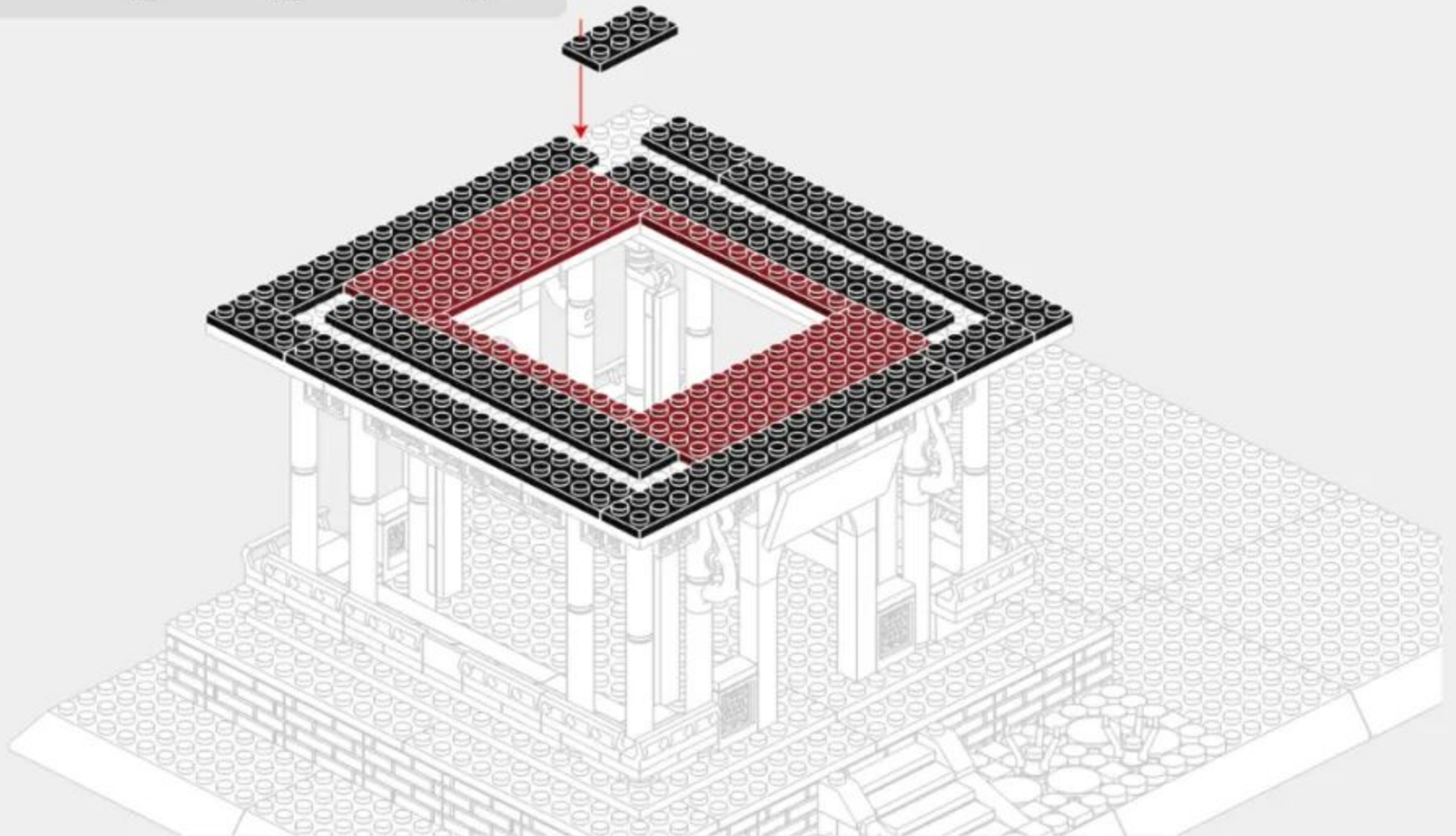
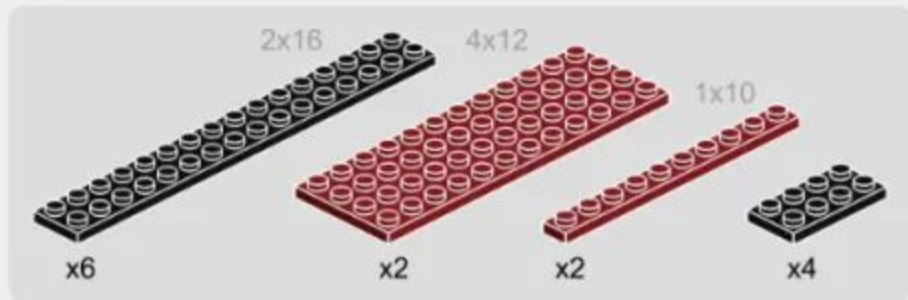

3-3

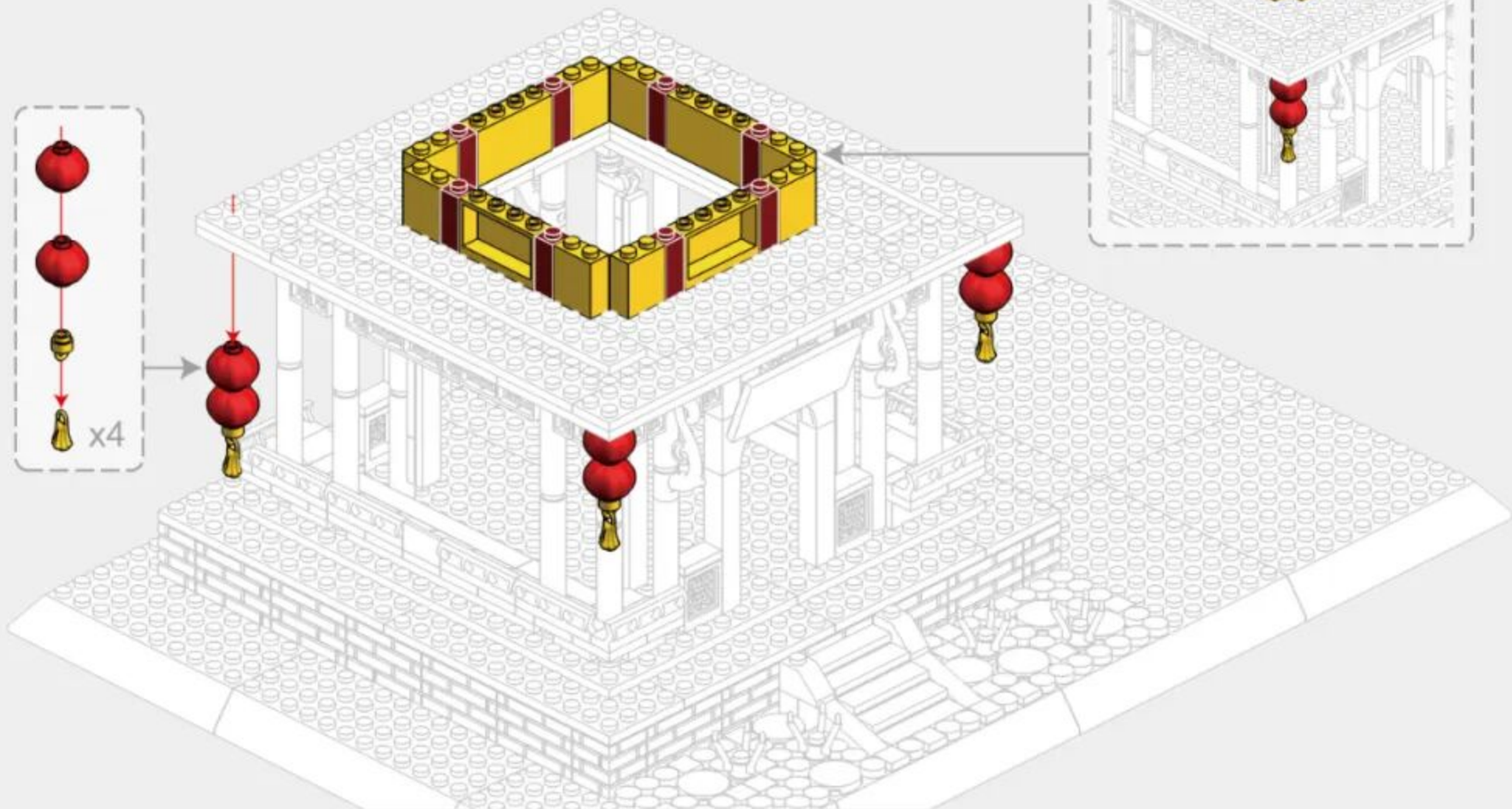
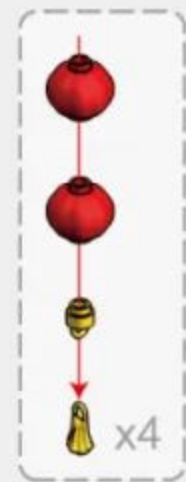

3-4

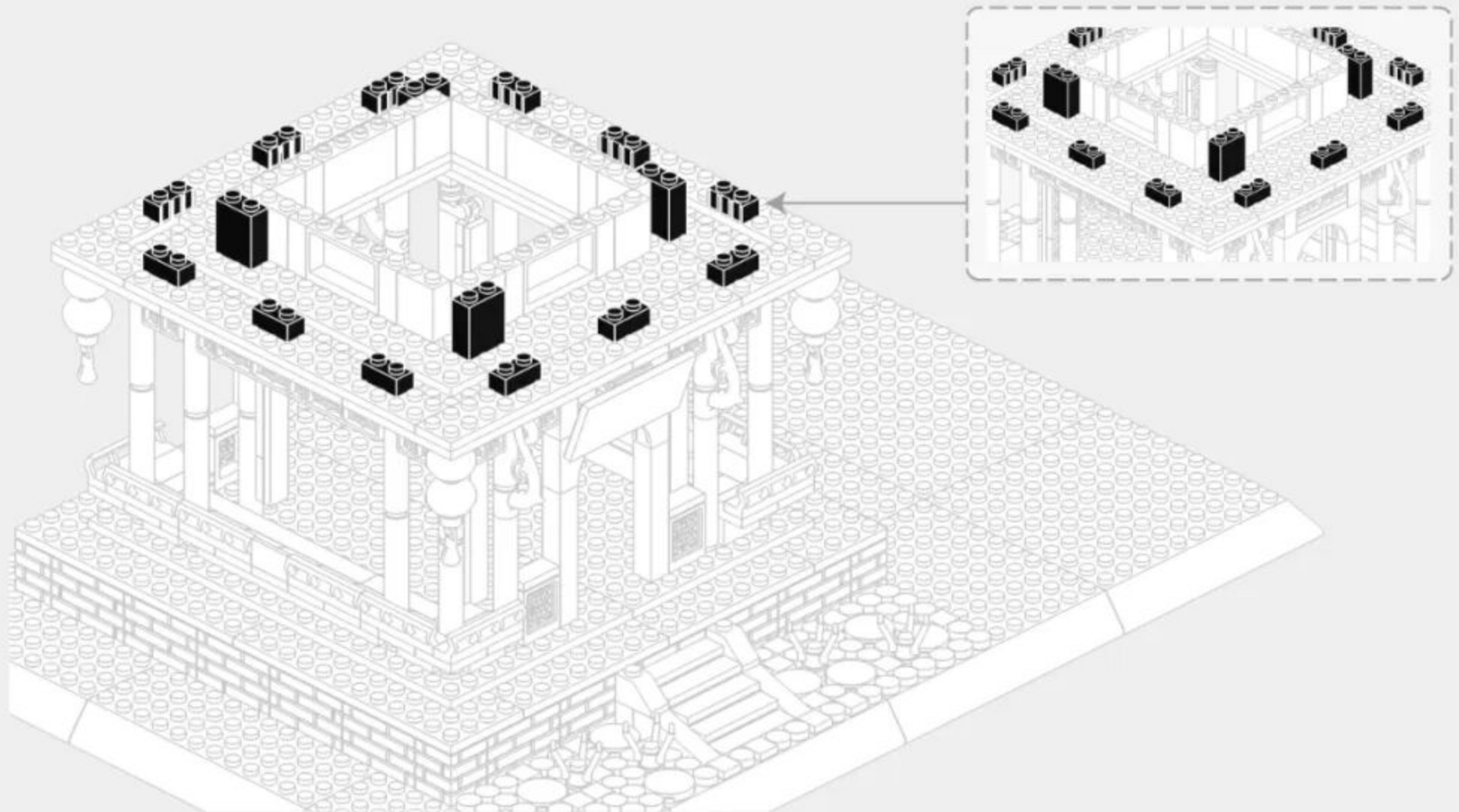

3-5

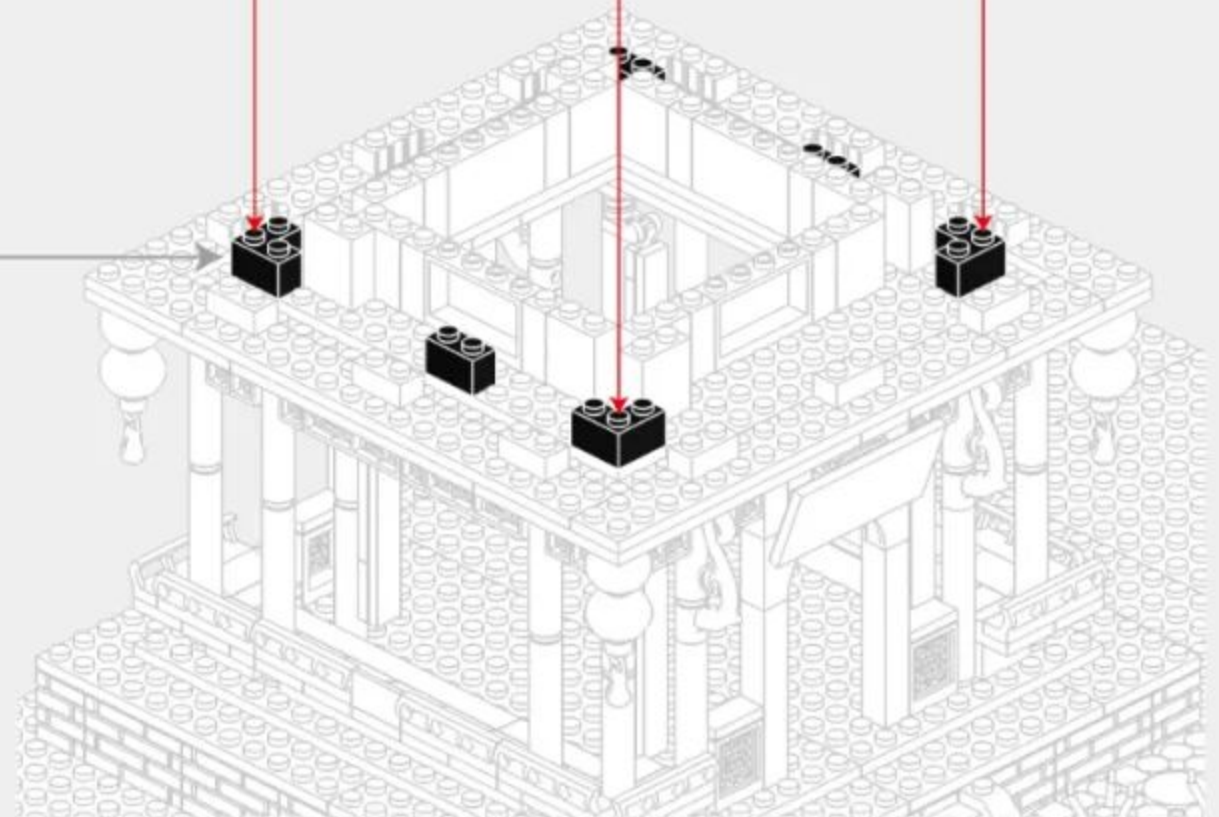
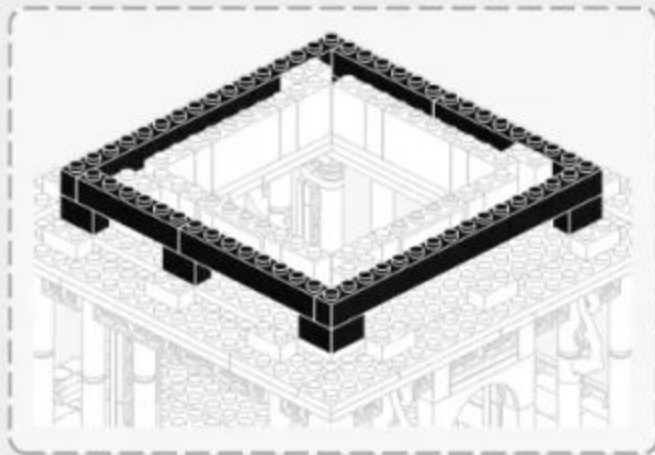
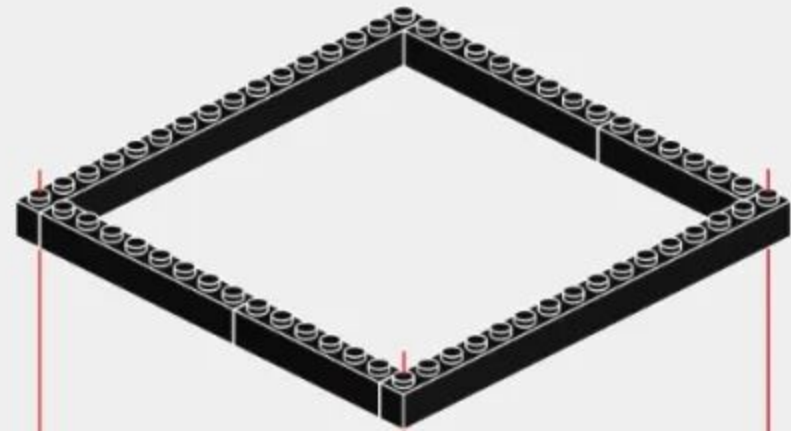
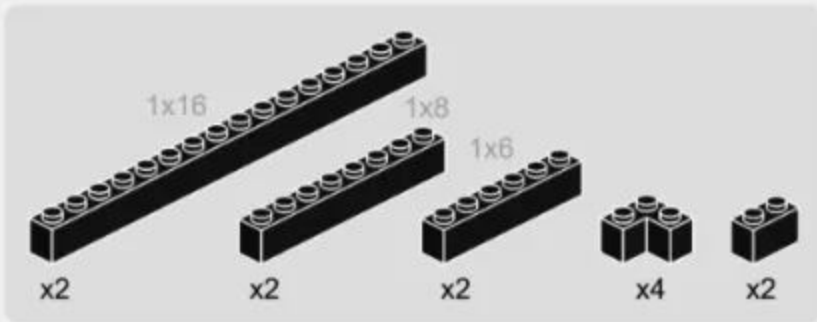

3-6

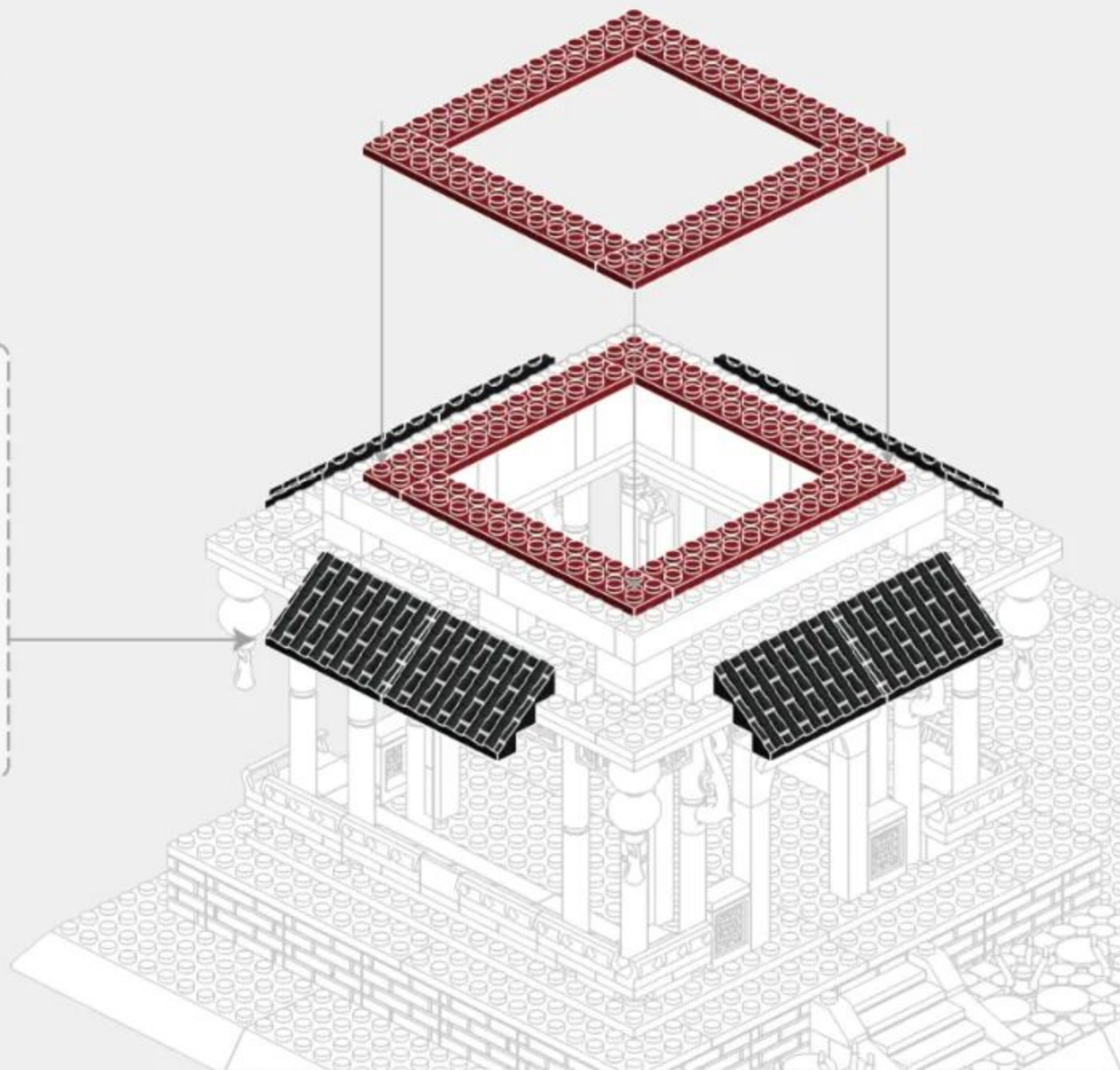
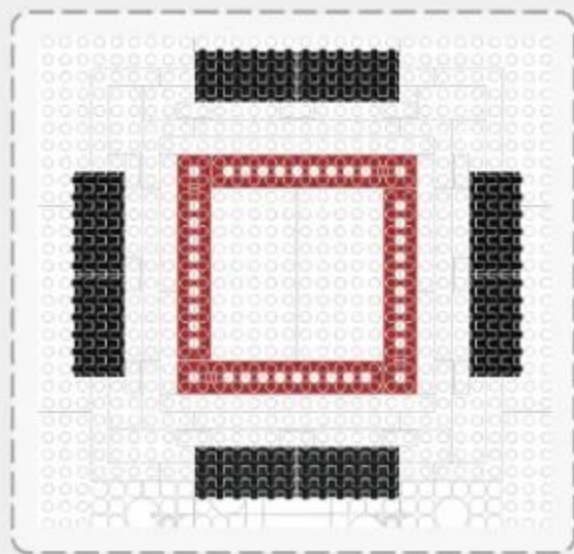
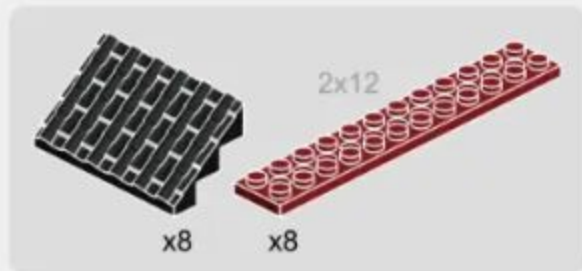

3-7

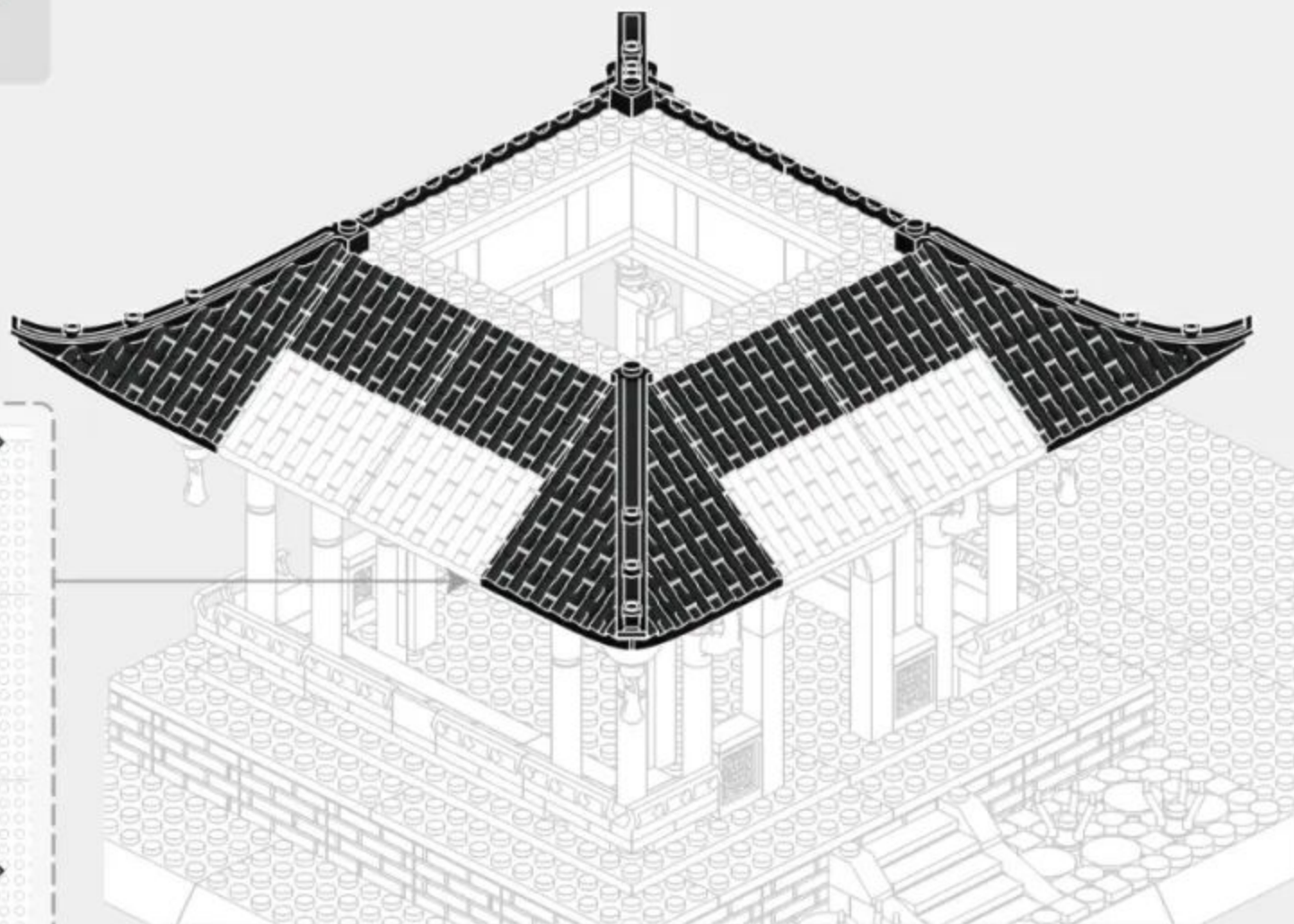
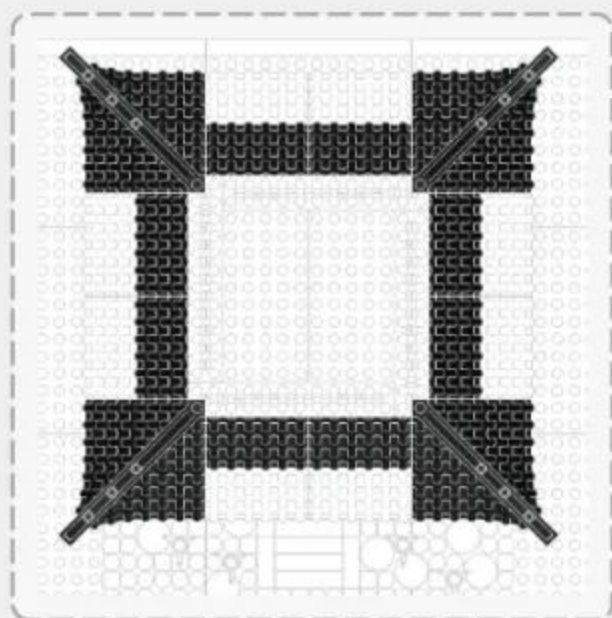
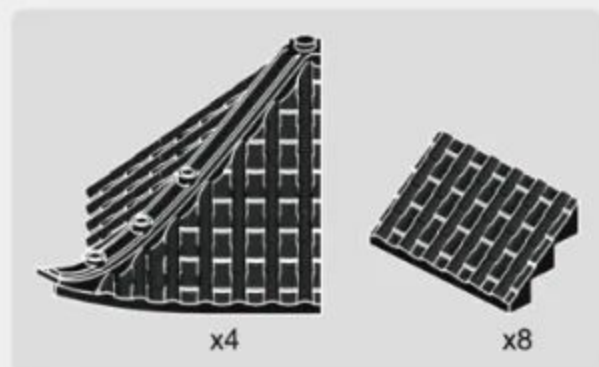

3-8

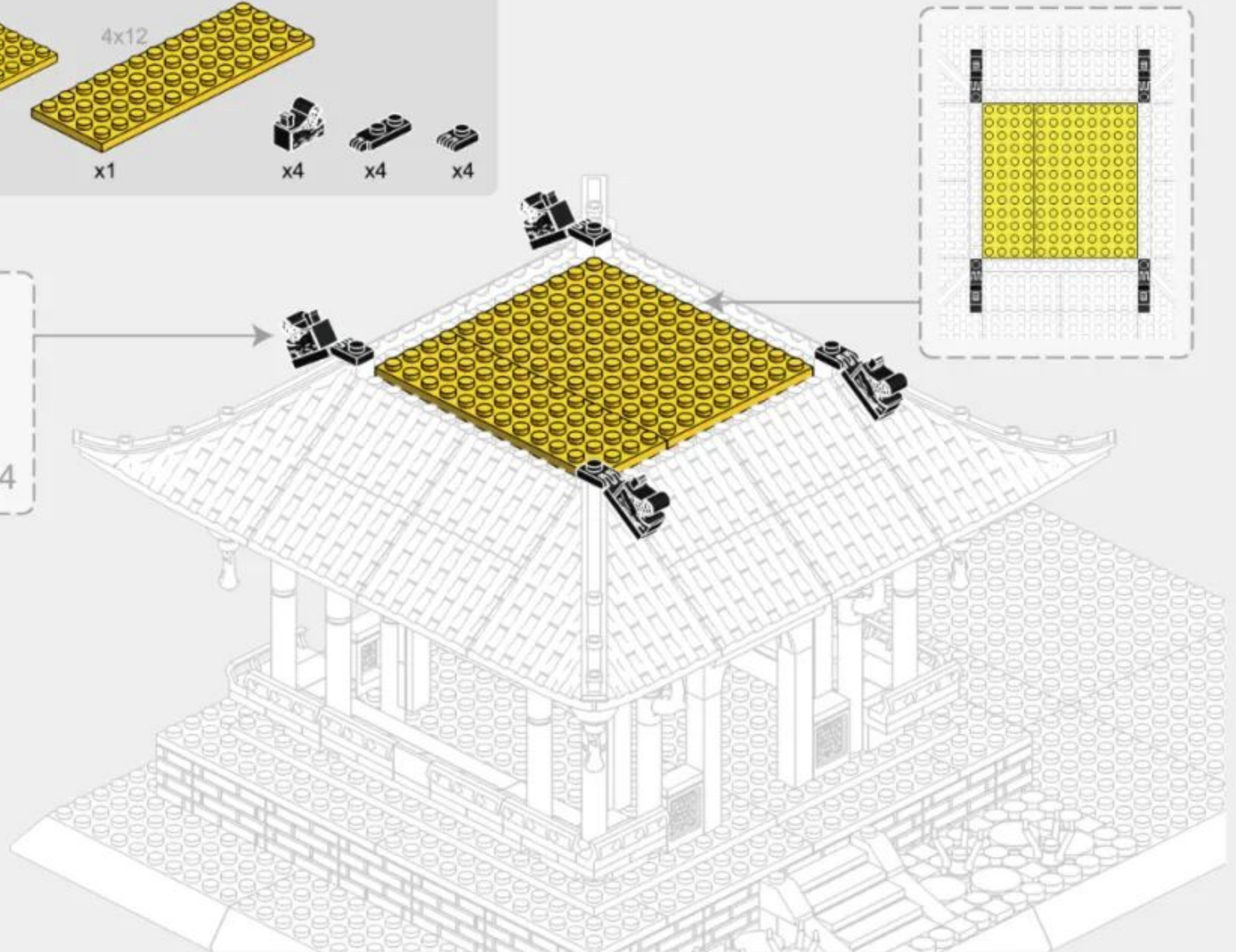
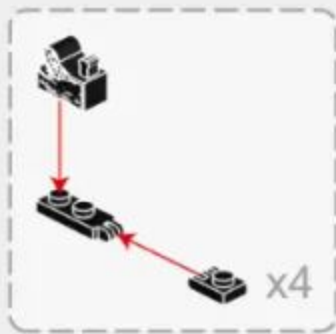
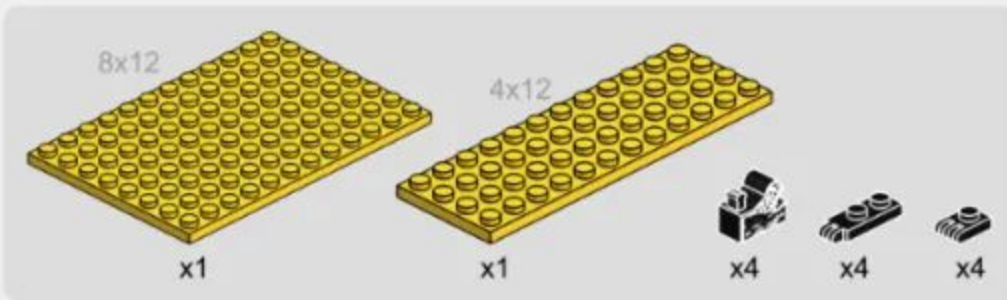

3-9

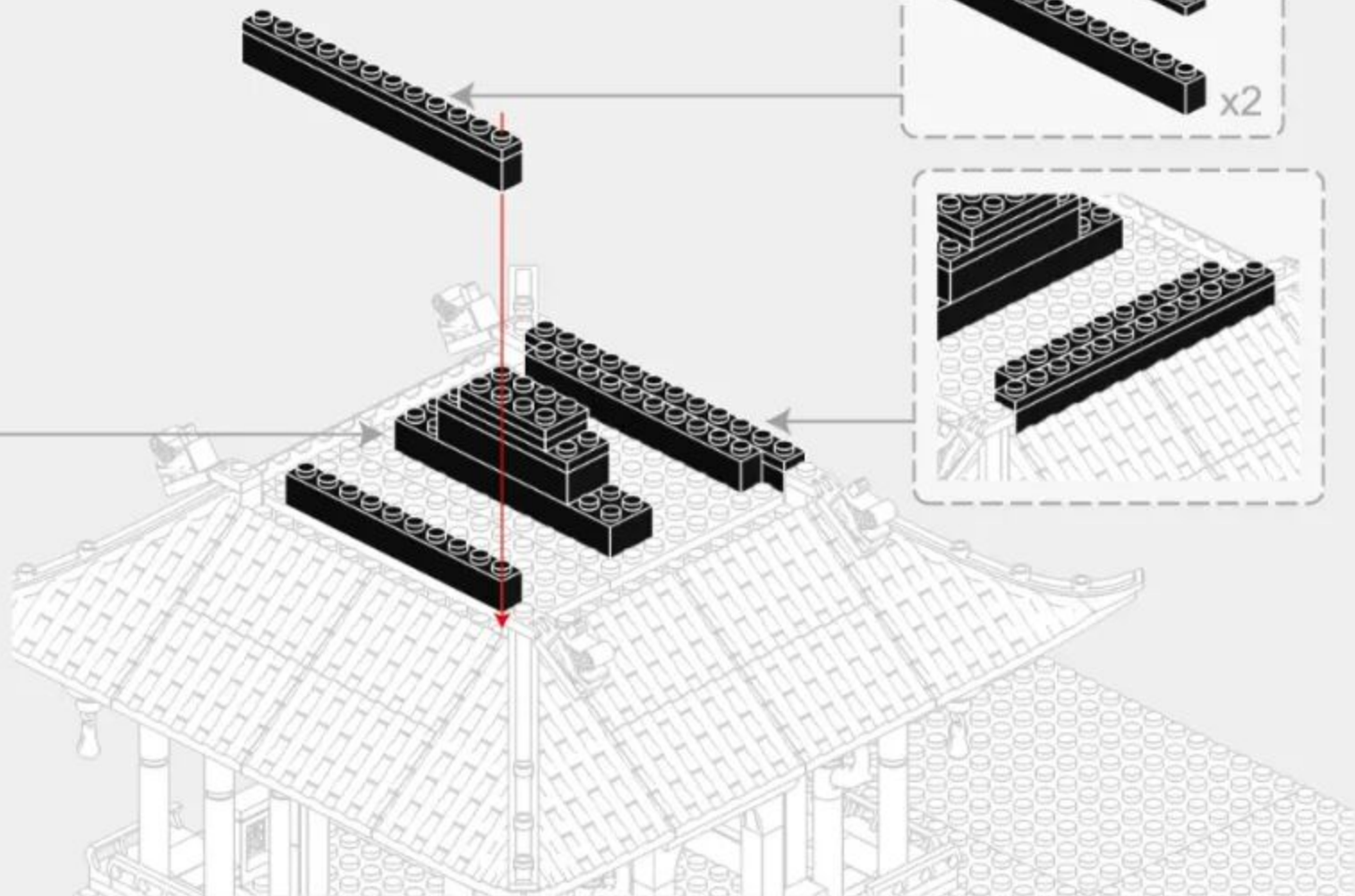
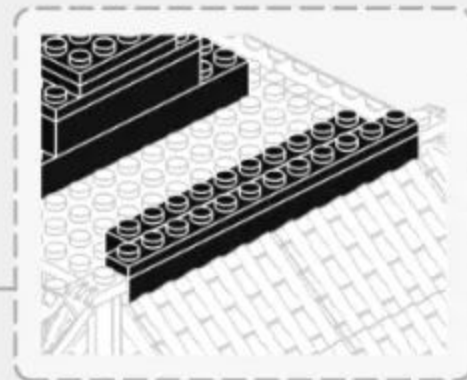
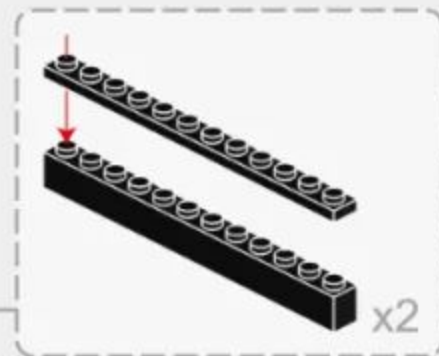
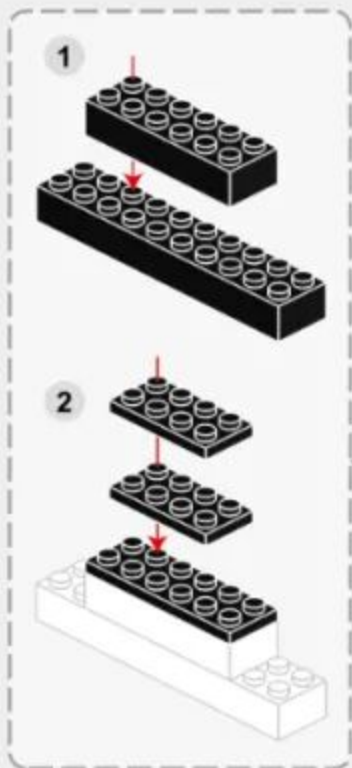
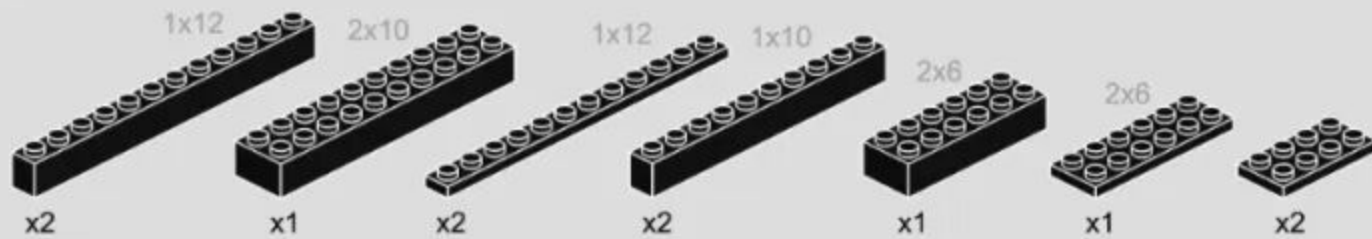

3-10

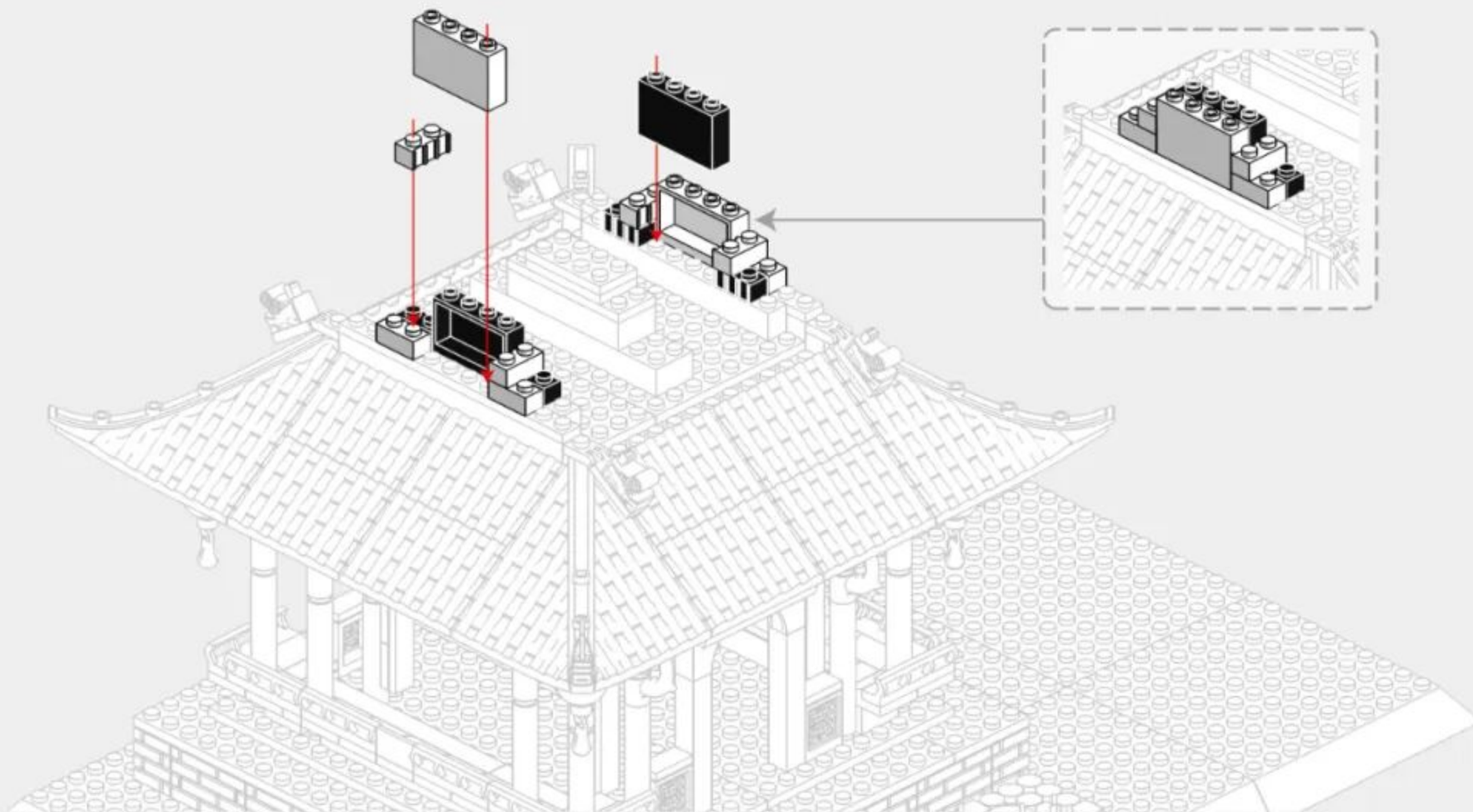
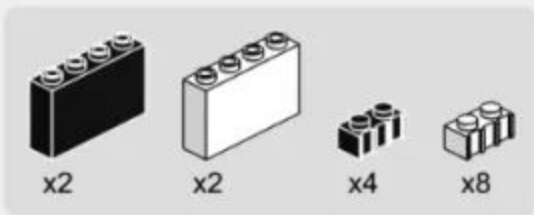

3-11

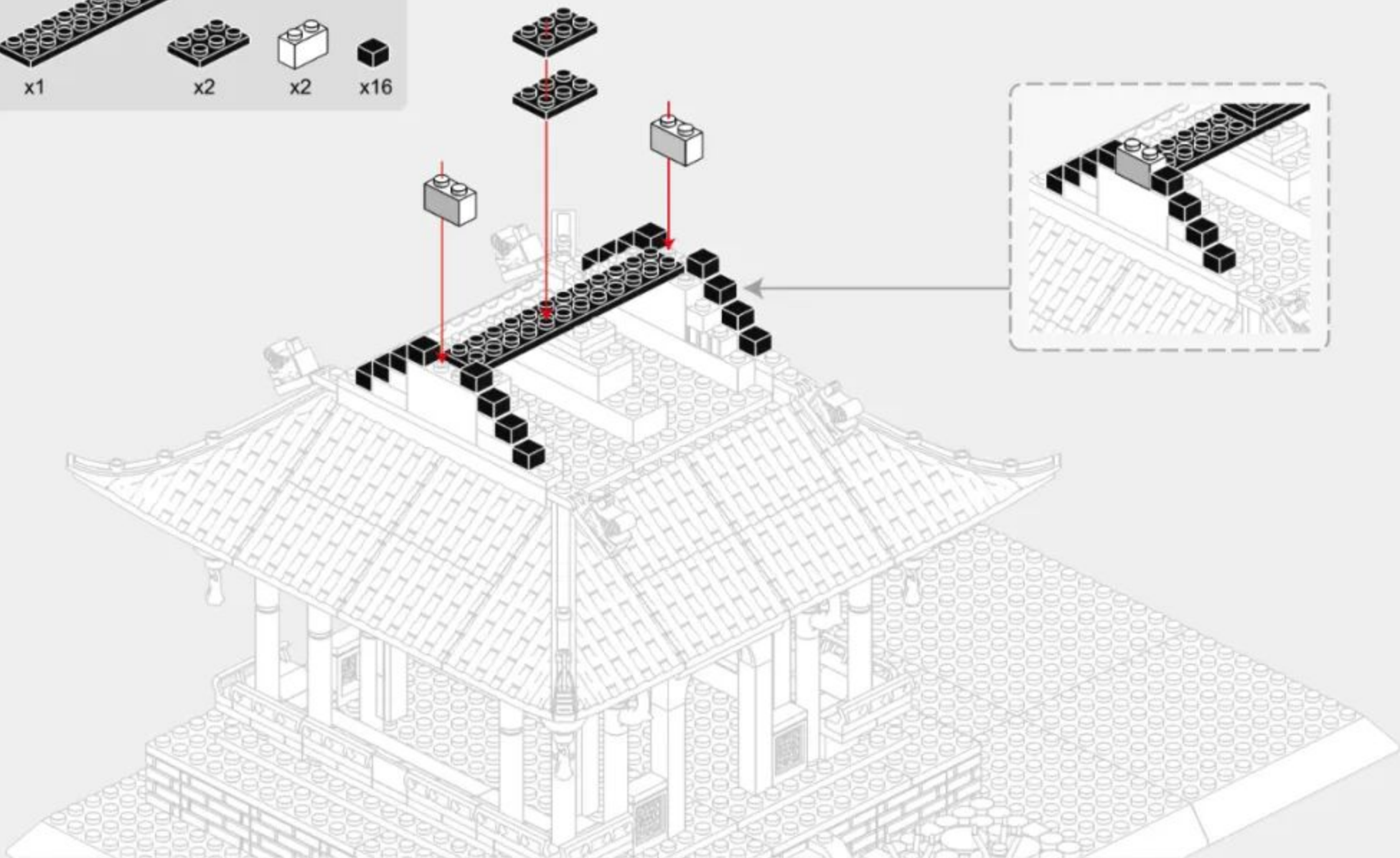
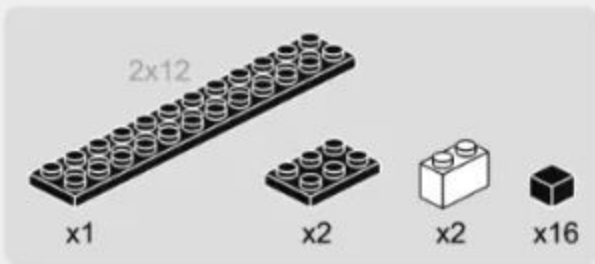

3-12

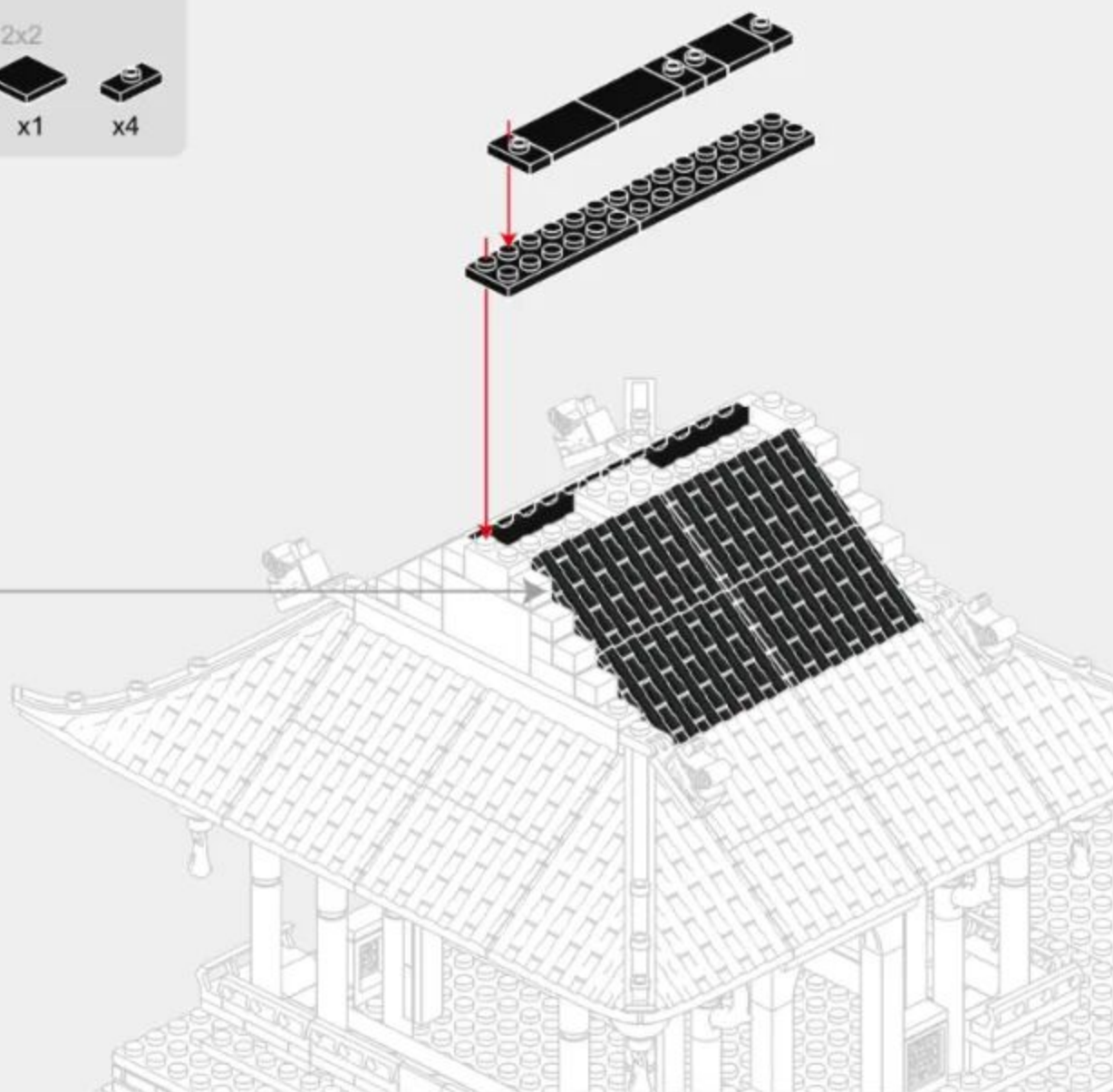
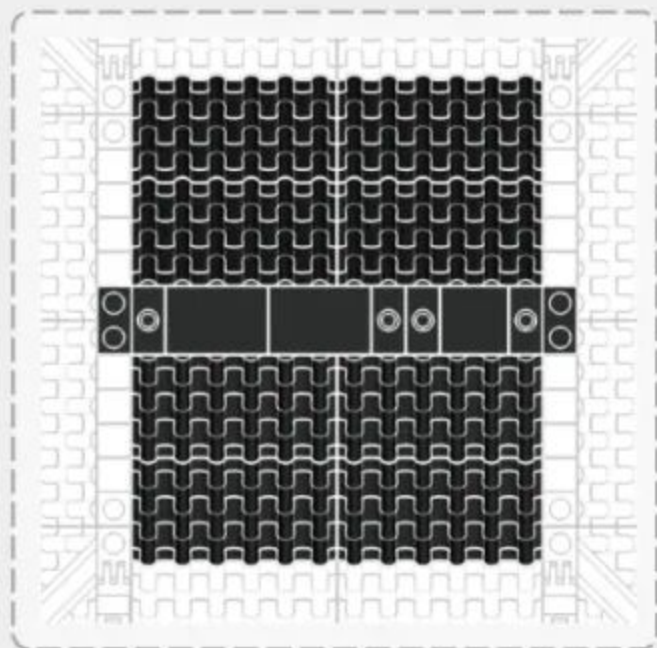
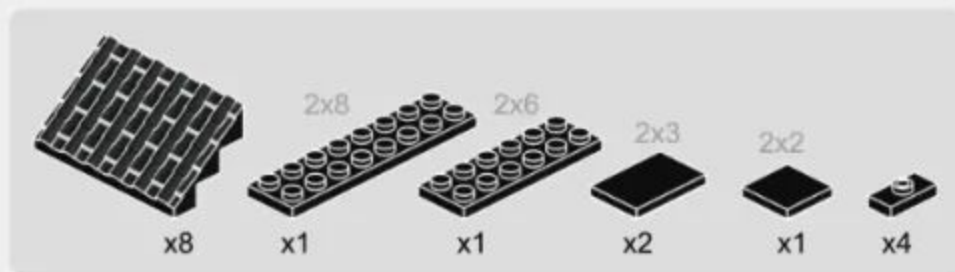



**4**  
**PACK**

**249PCS**

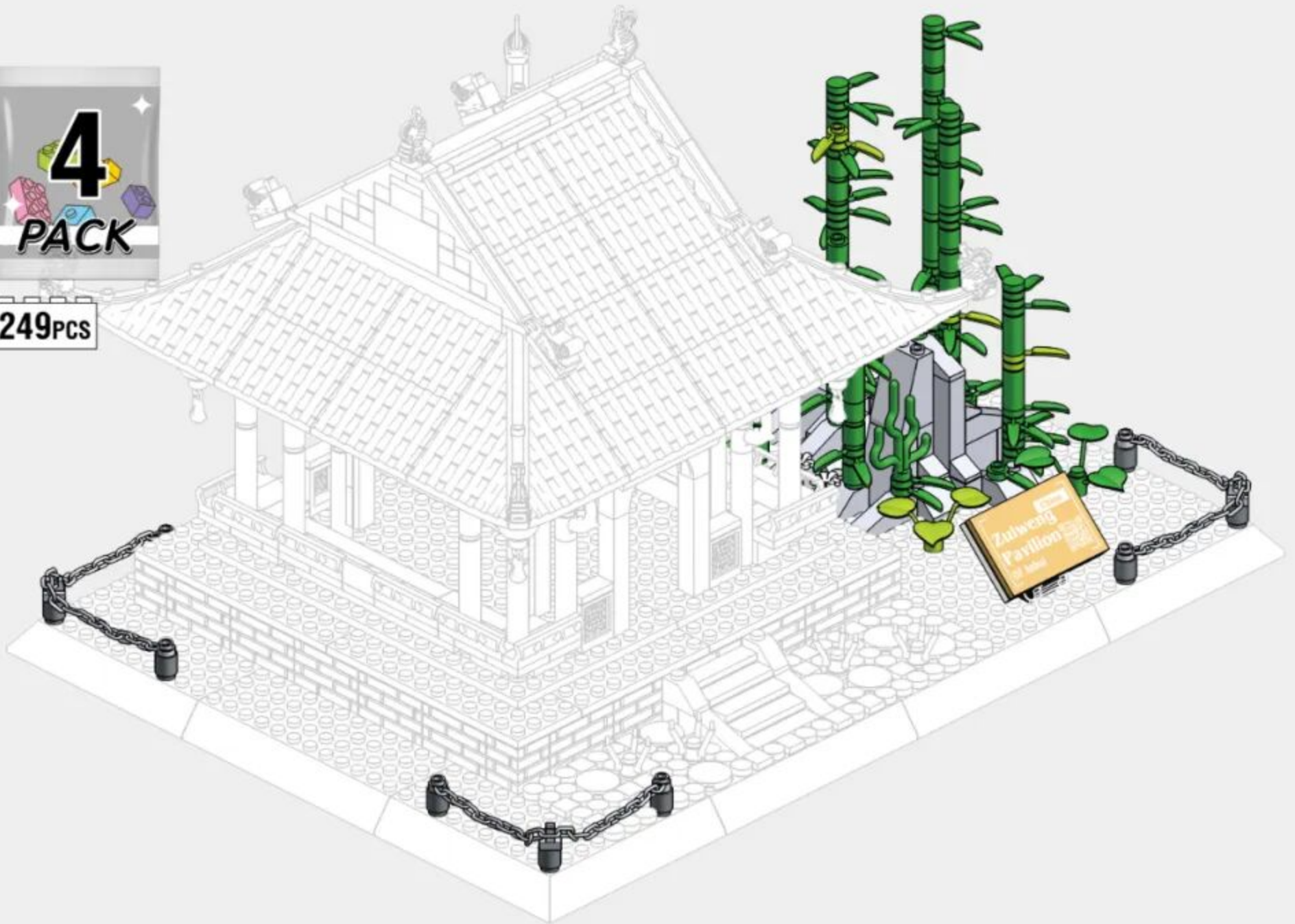

**51**

4-1

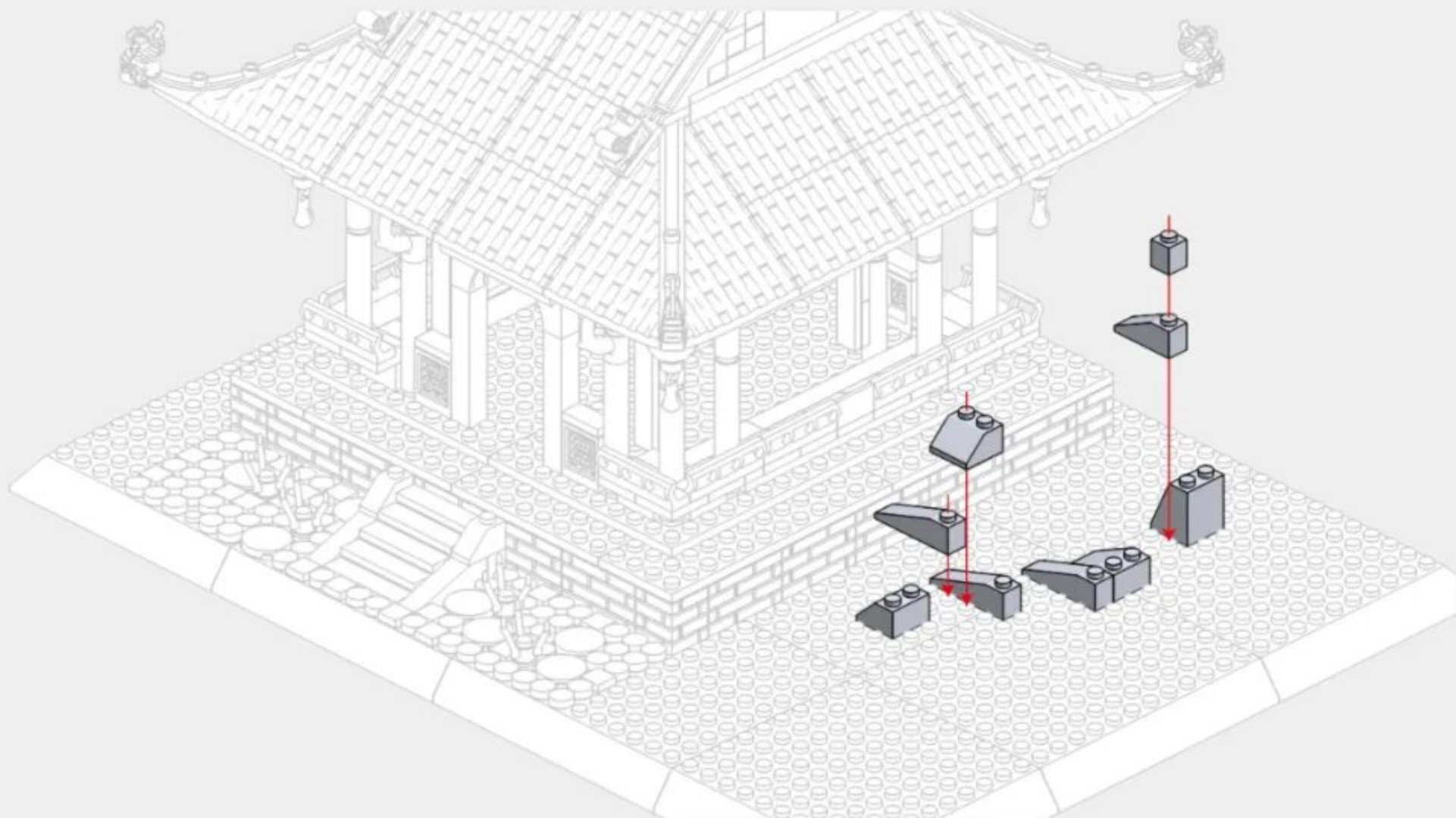
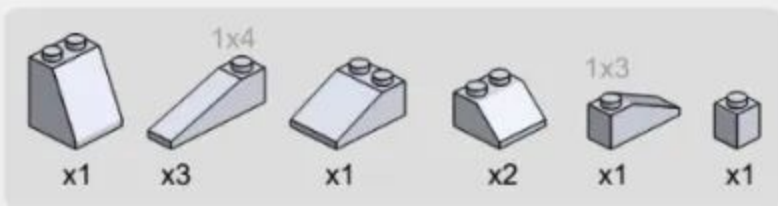

4-2

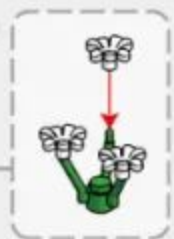
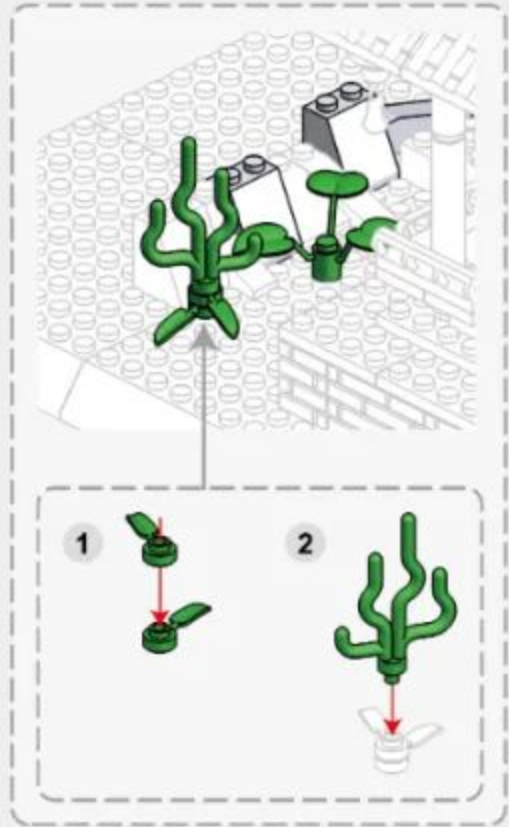
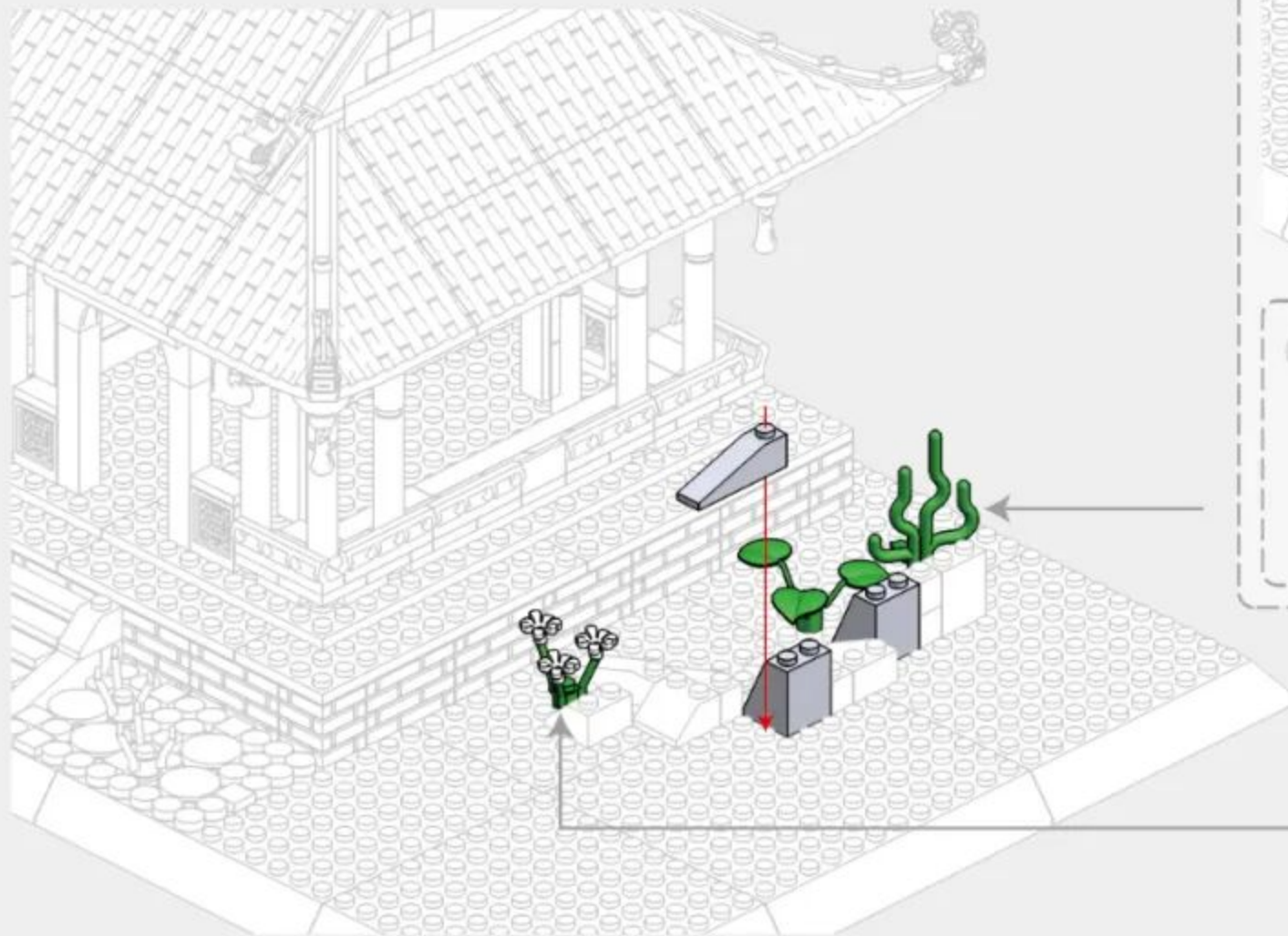
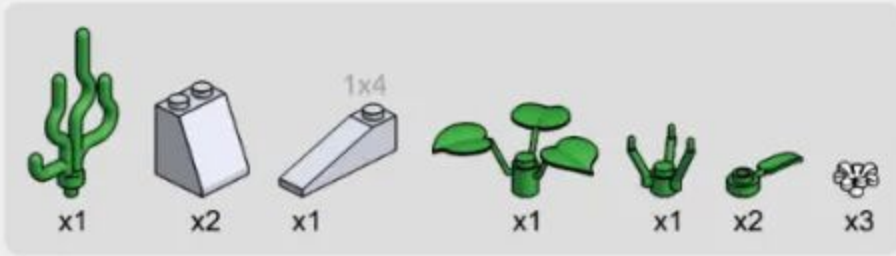



# 4-4

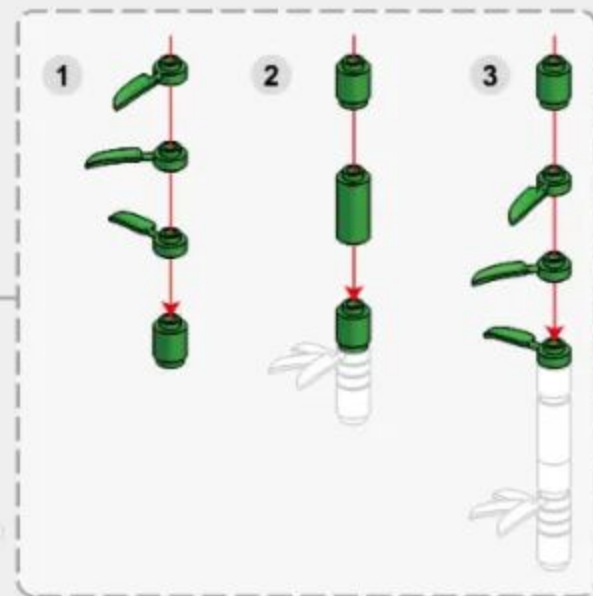
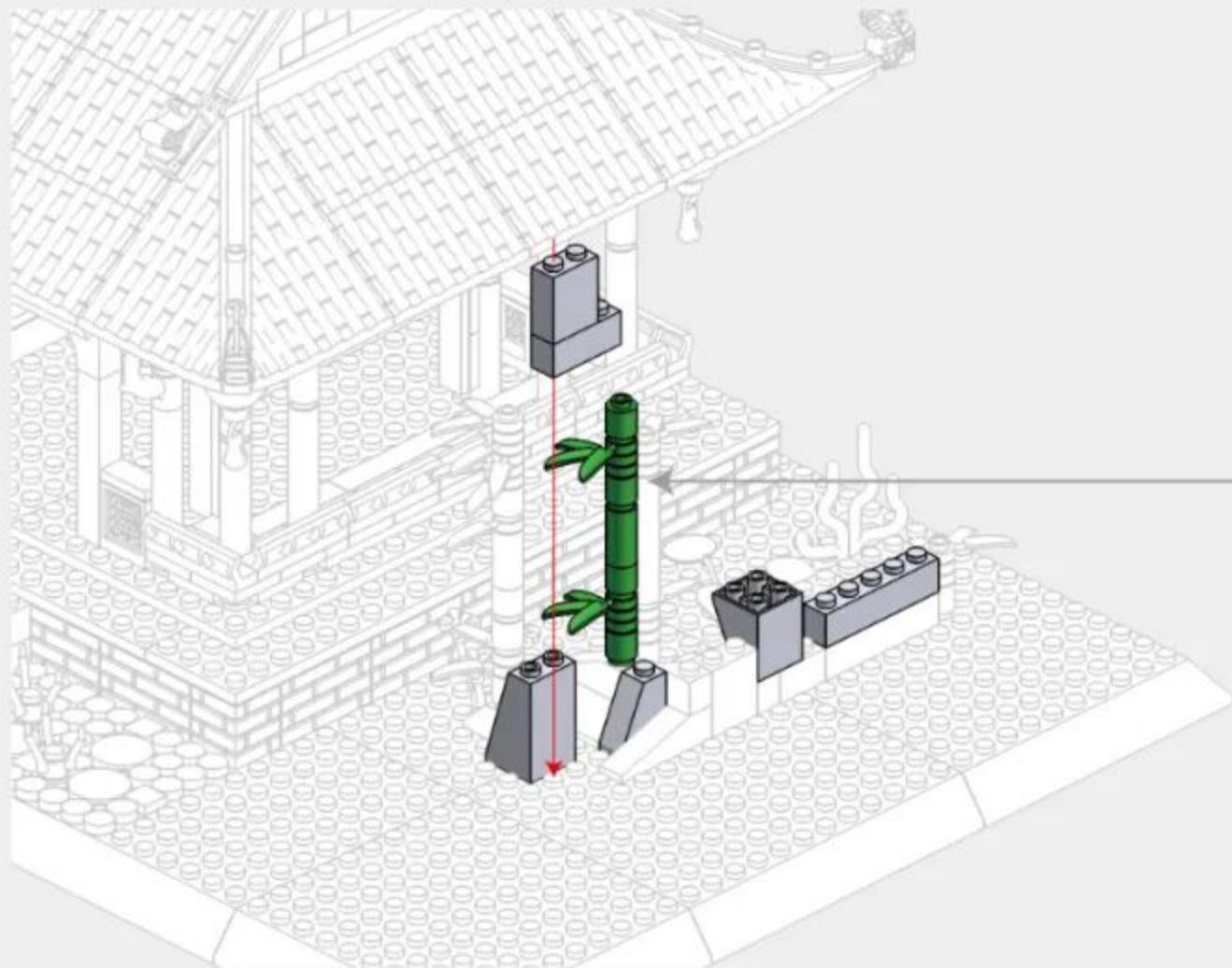
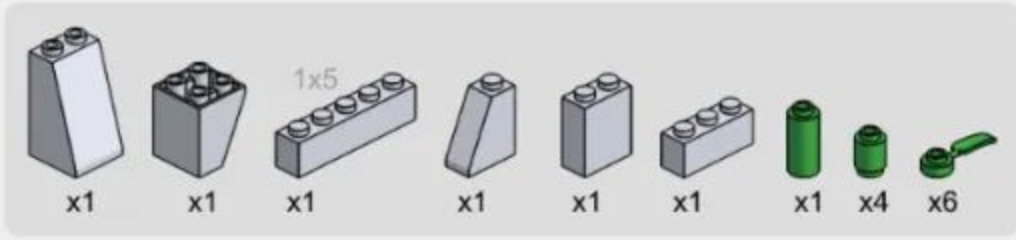

4-5

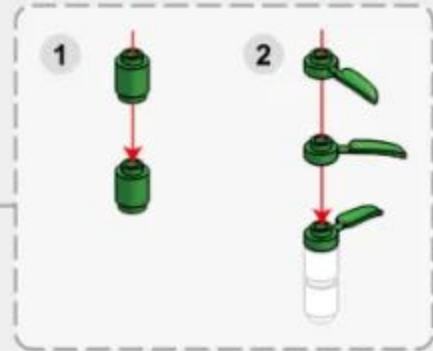
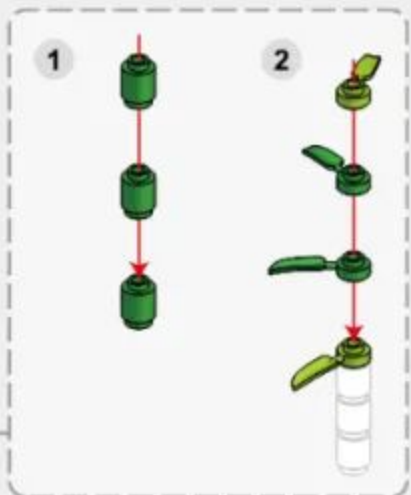
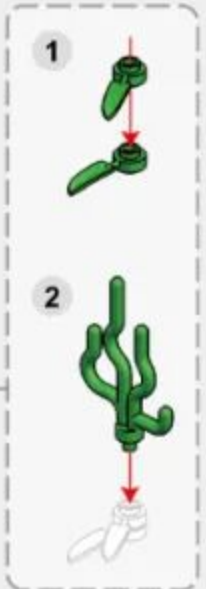
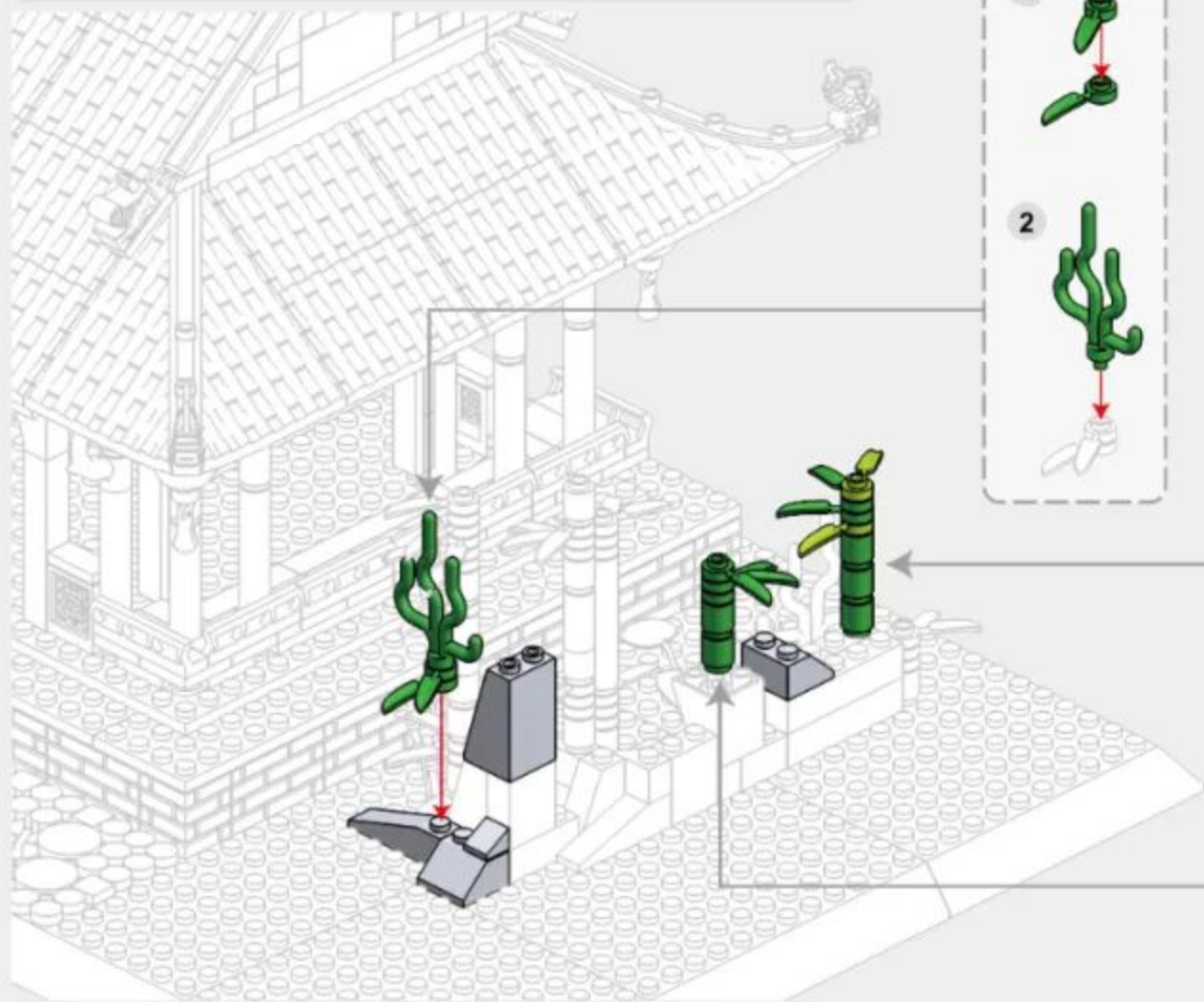
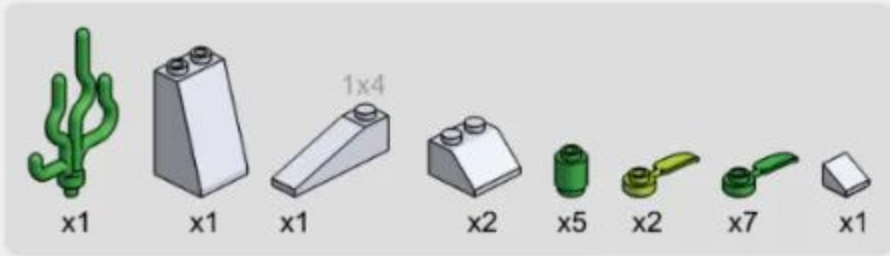

4-6

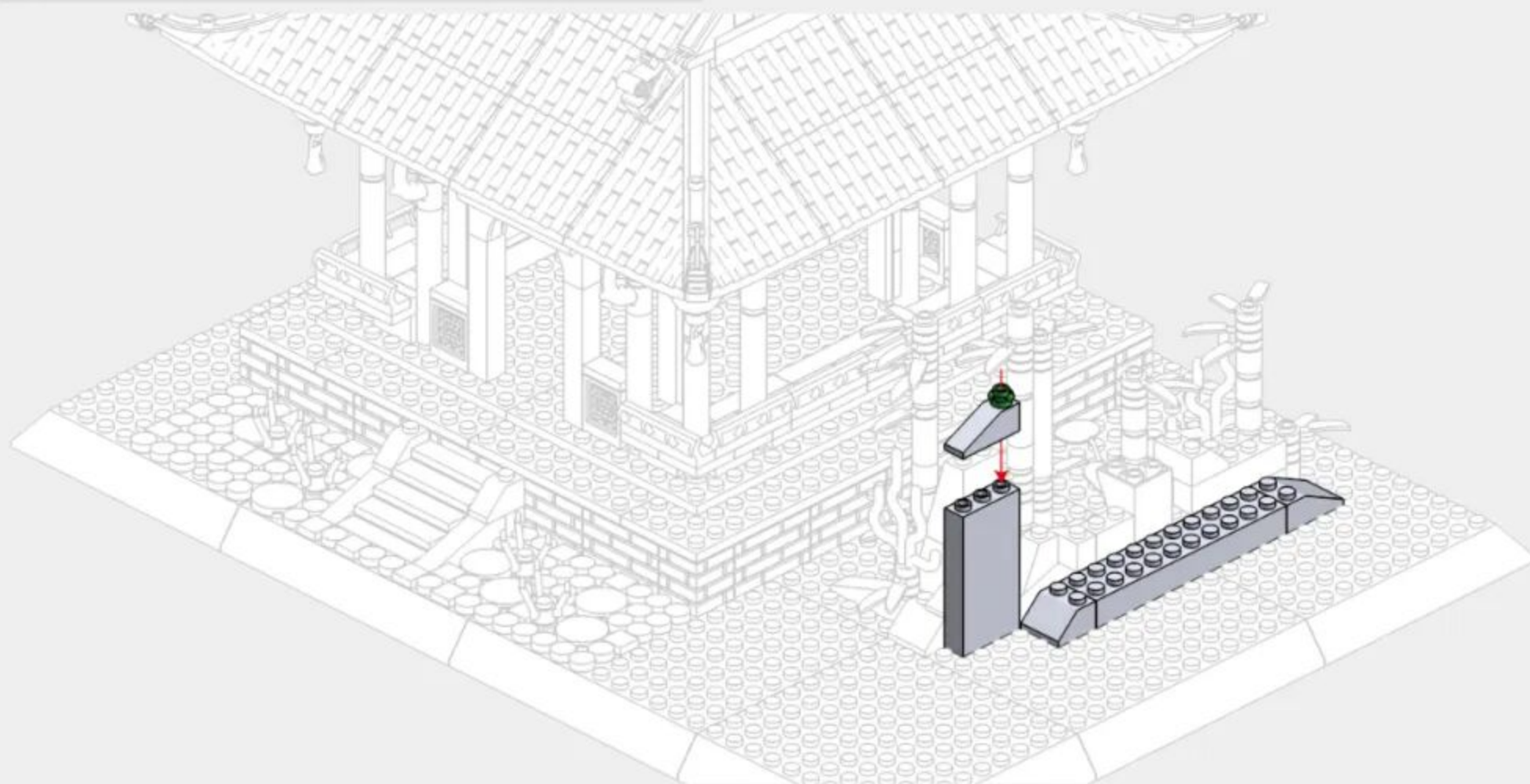
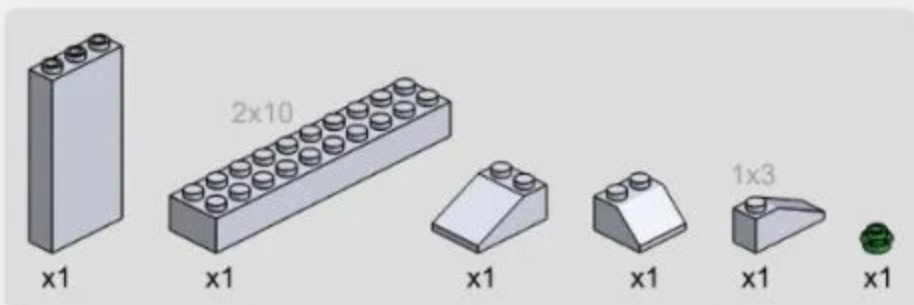

4-7

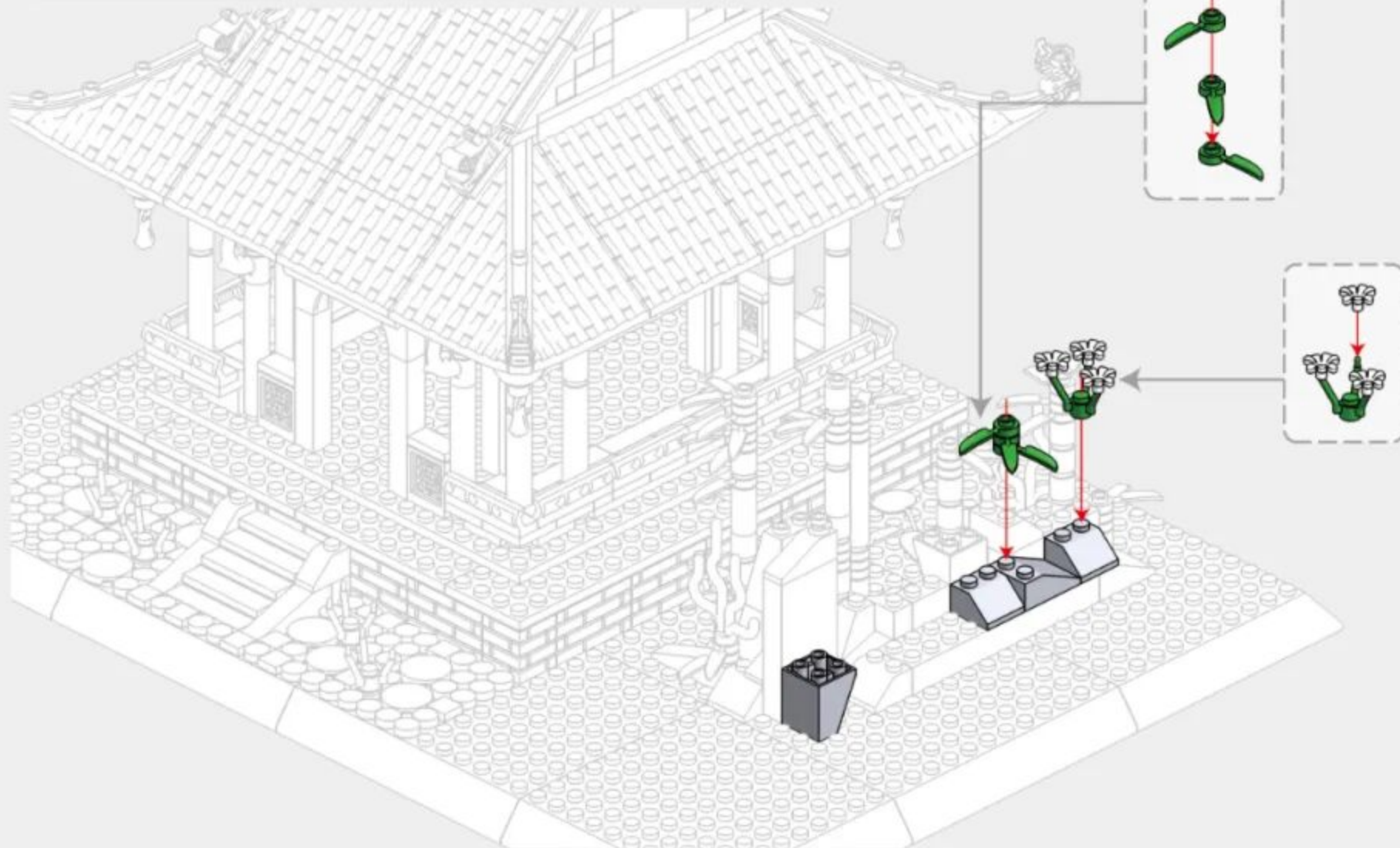

4-8





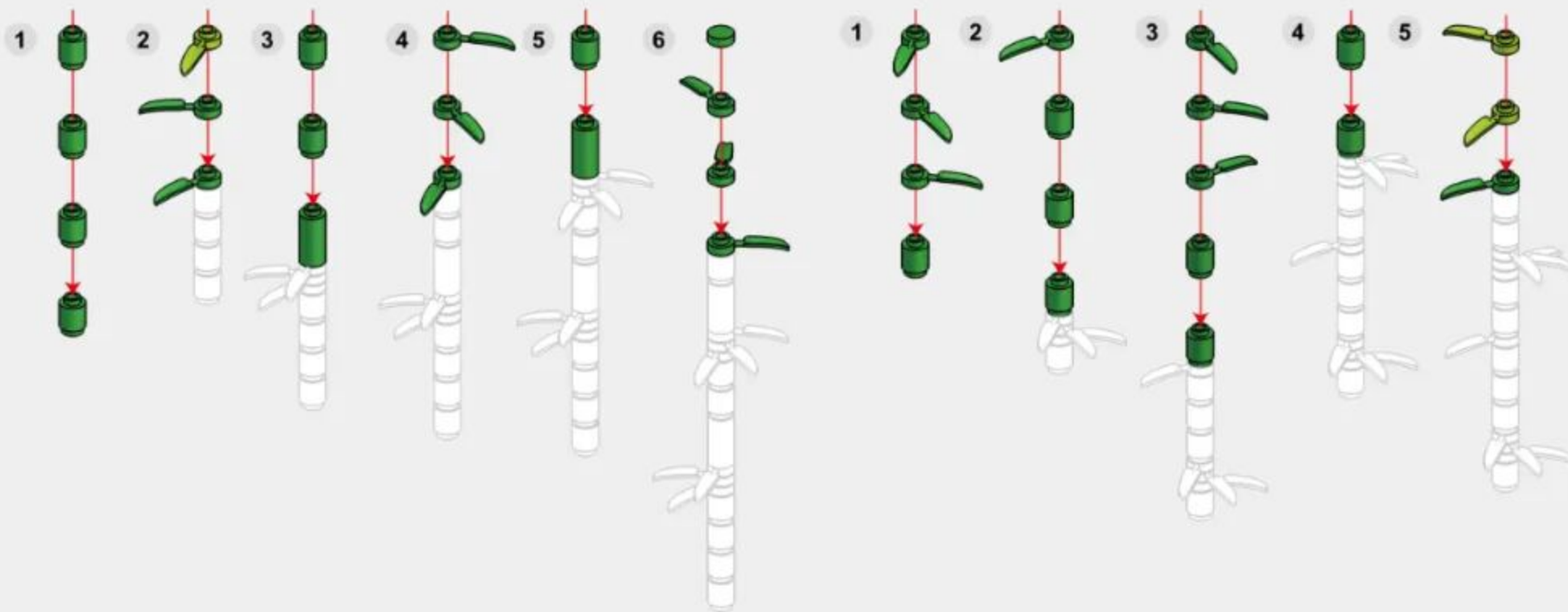



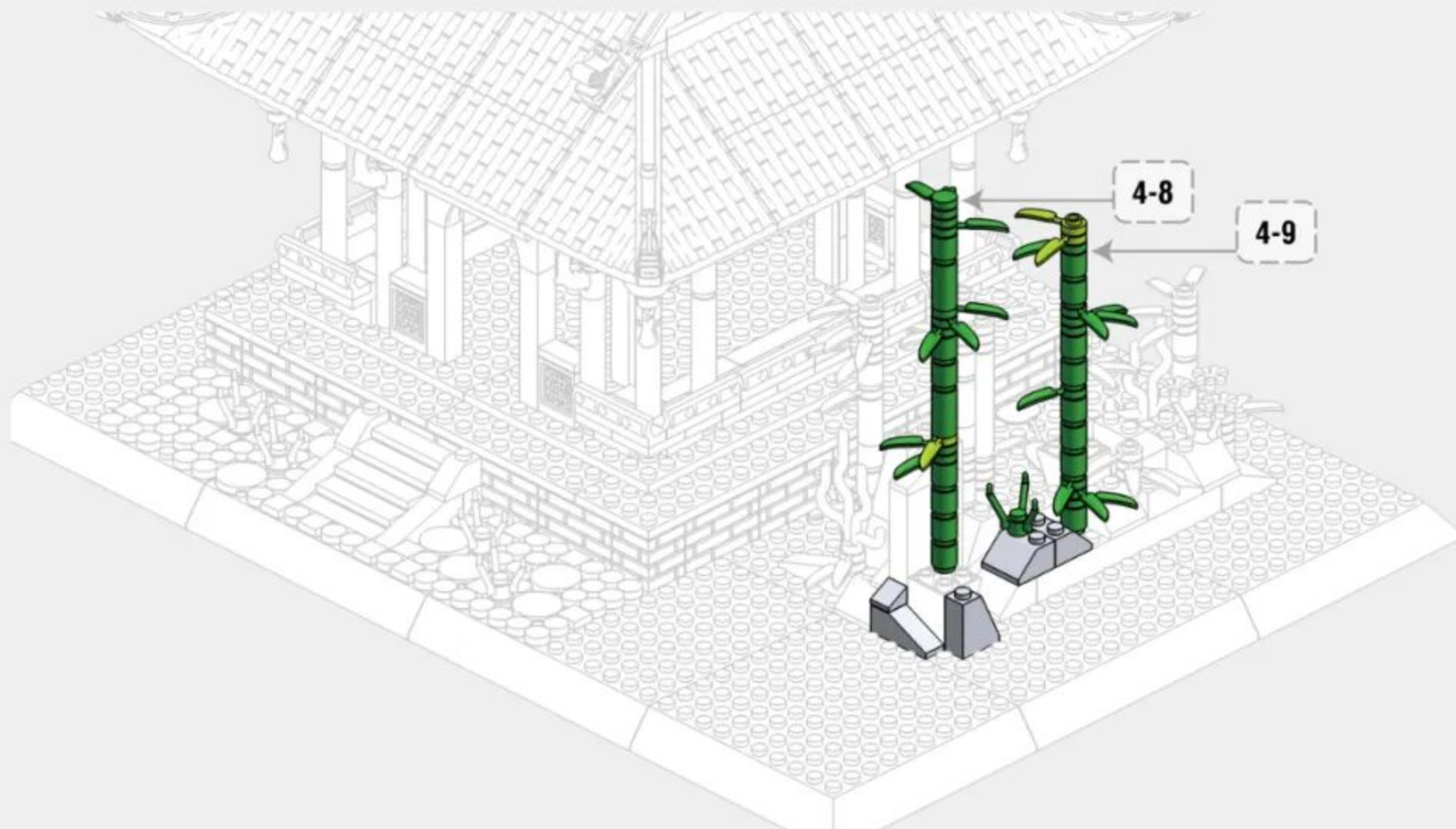



4-9



4-10



# 4-11

-  x1
-  x2
-  x1
-  x2
-  x1
-  x1
-  x3
-  x4
-  x1
-  x1
-  x1

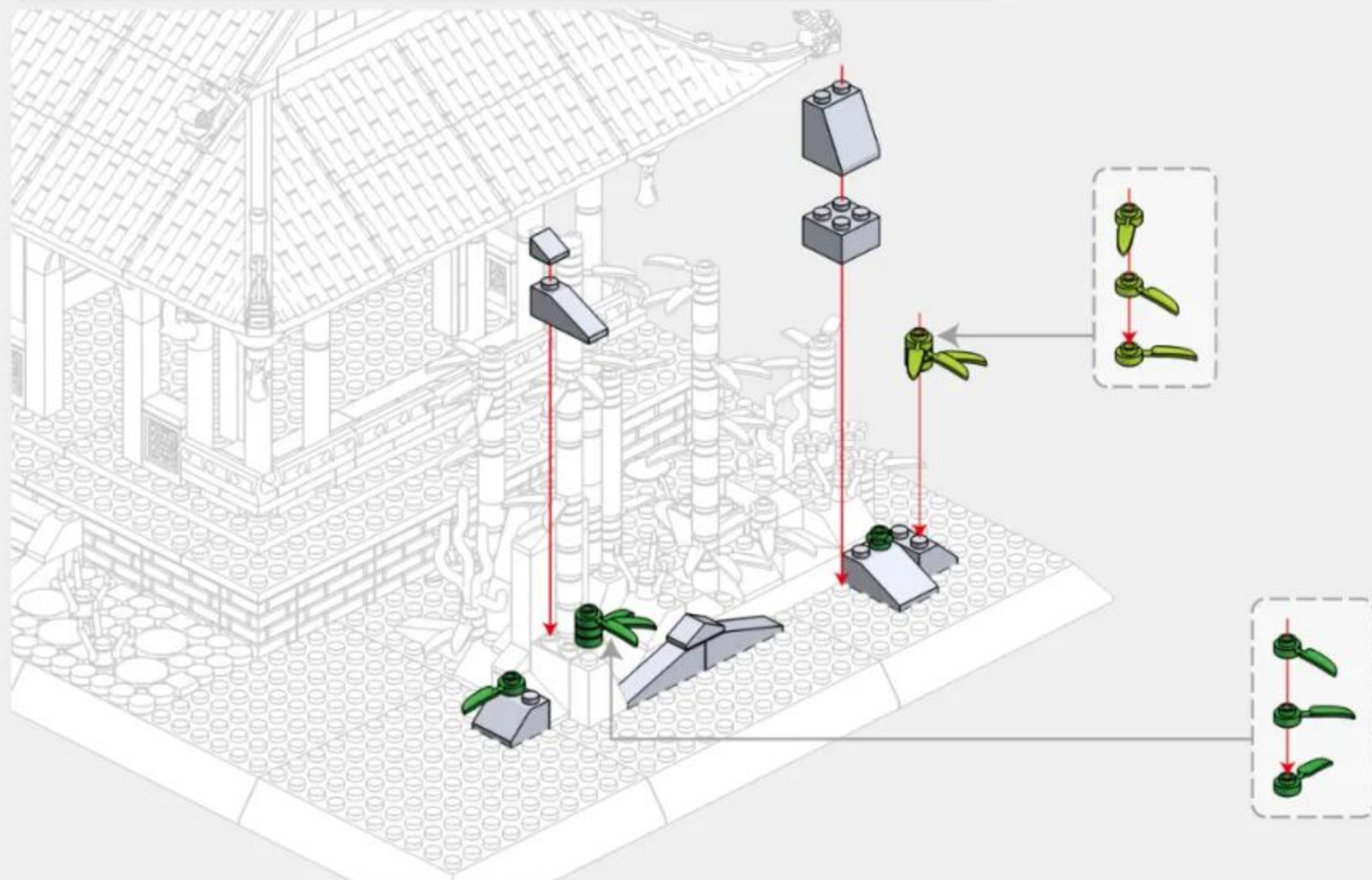

### 4-12

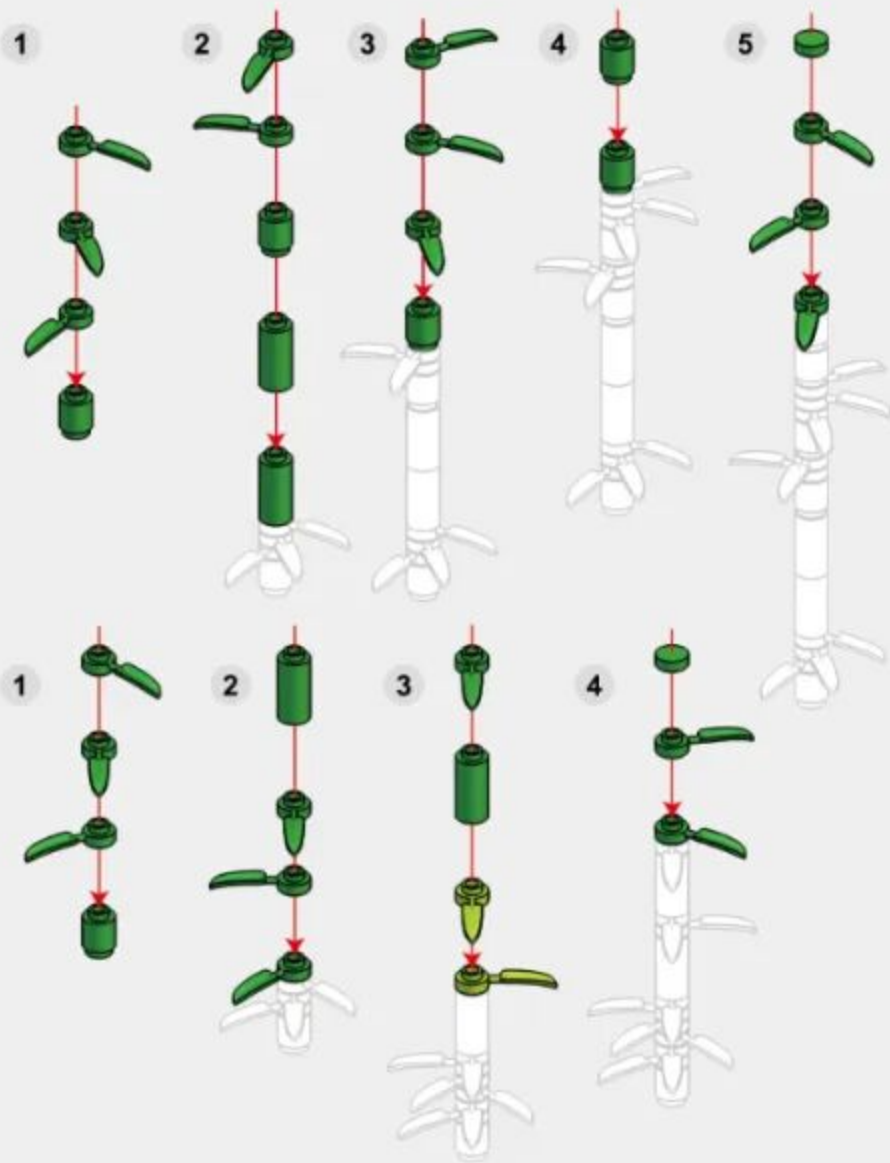

### 4-13

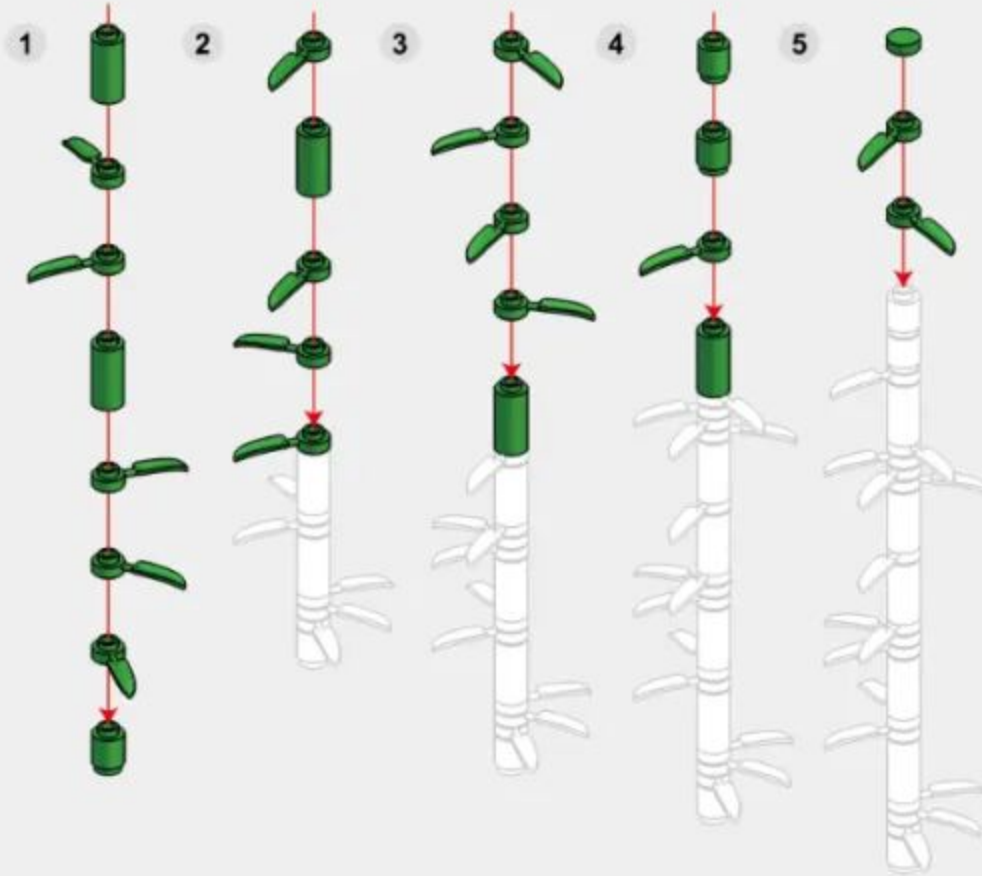

4-14



x1



x1

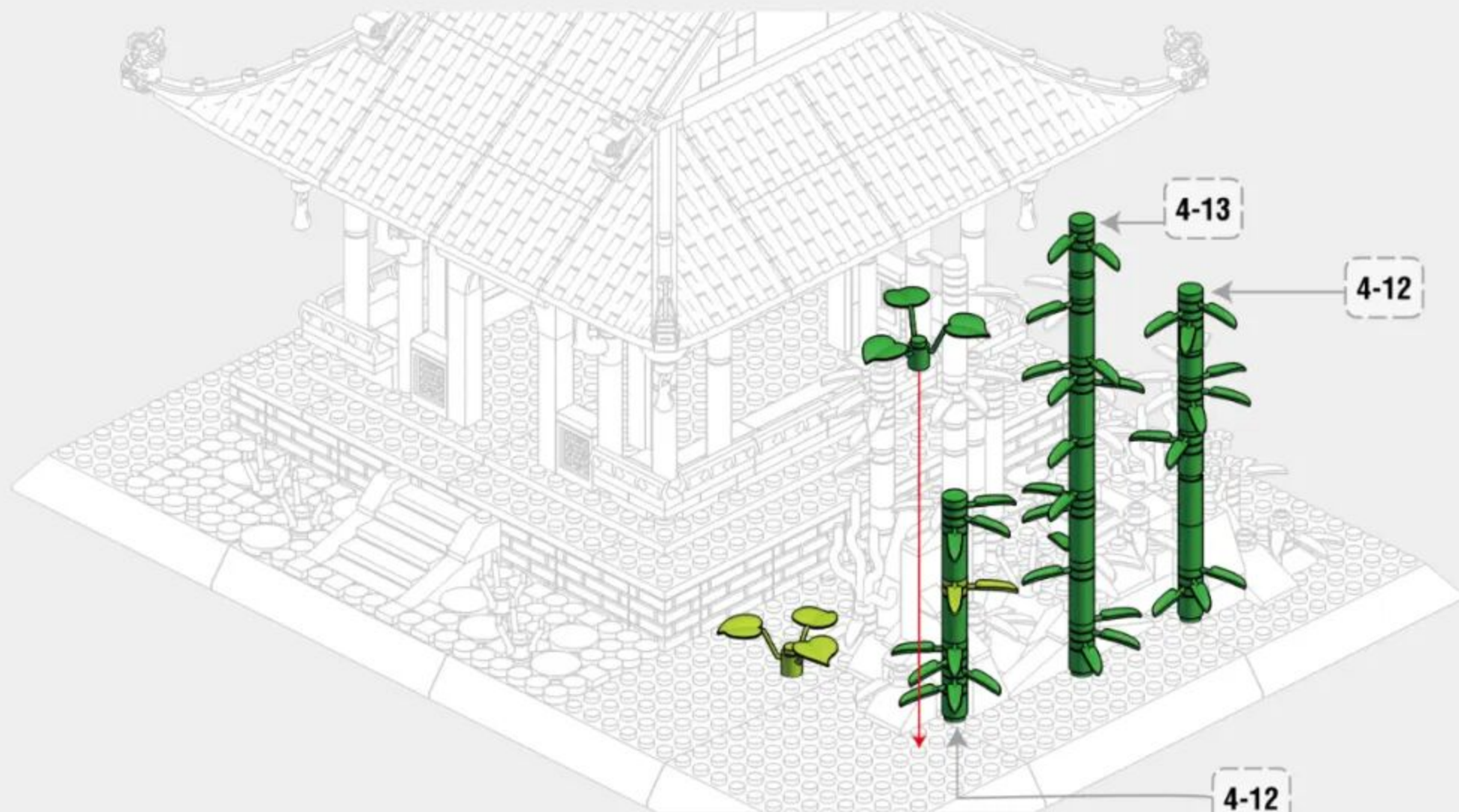

4-15

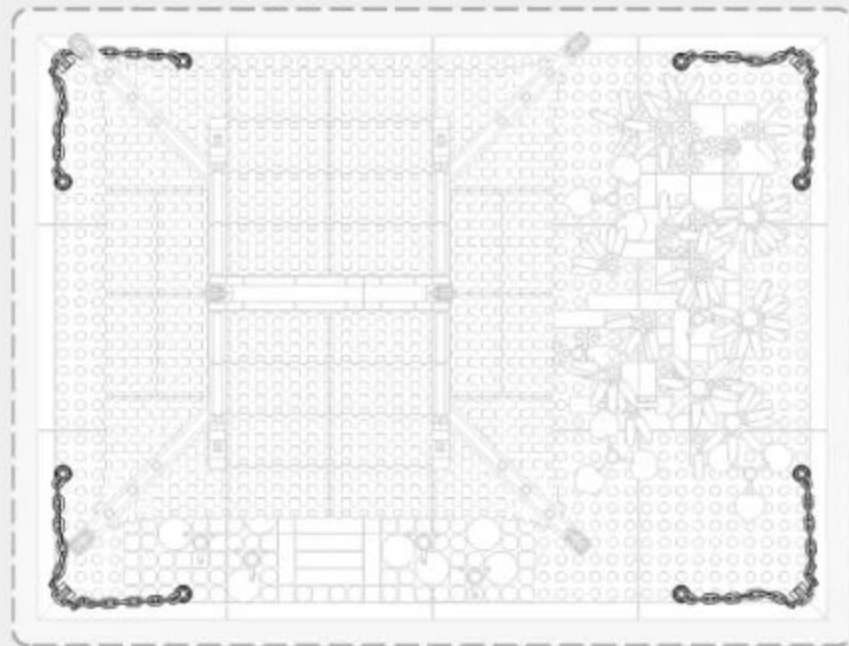
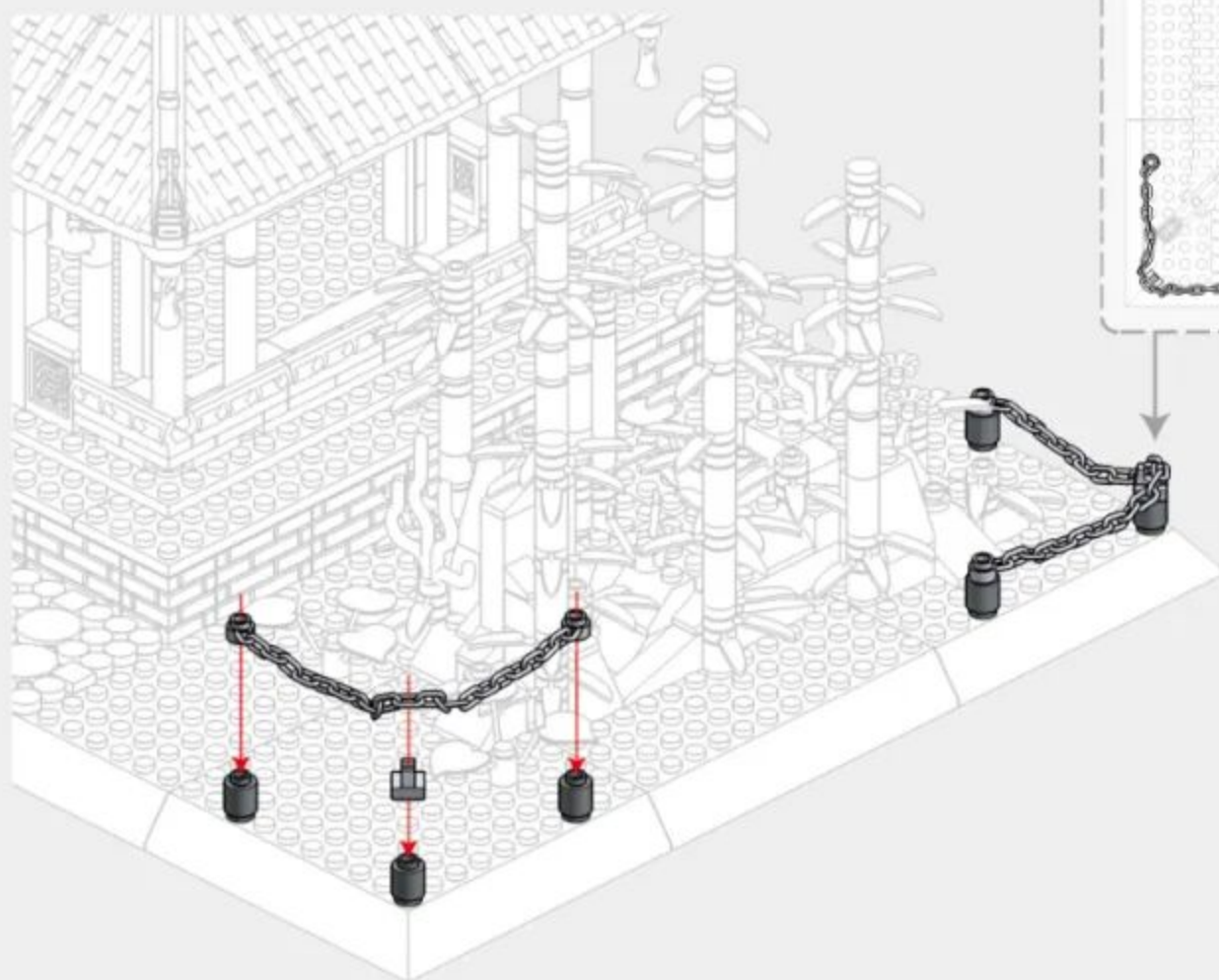

# 4-16

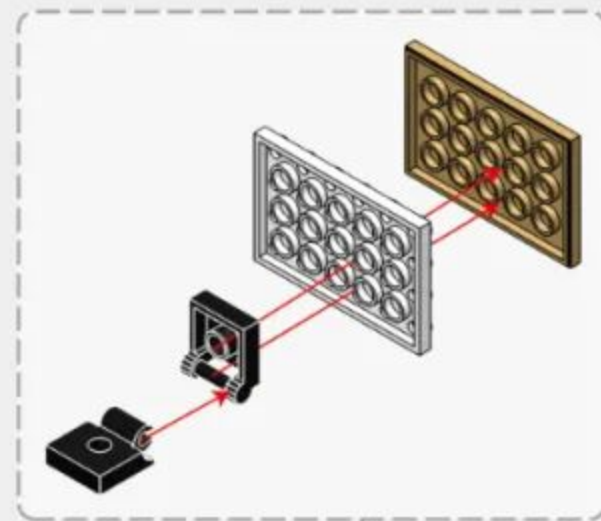
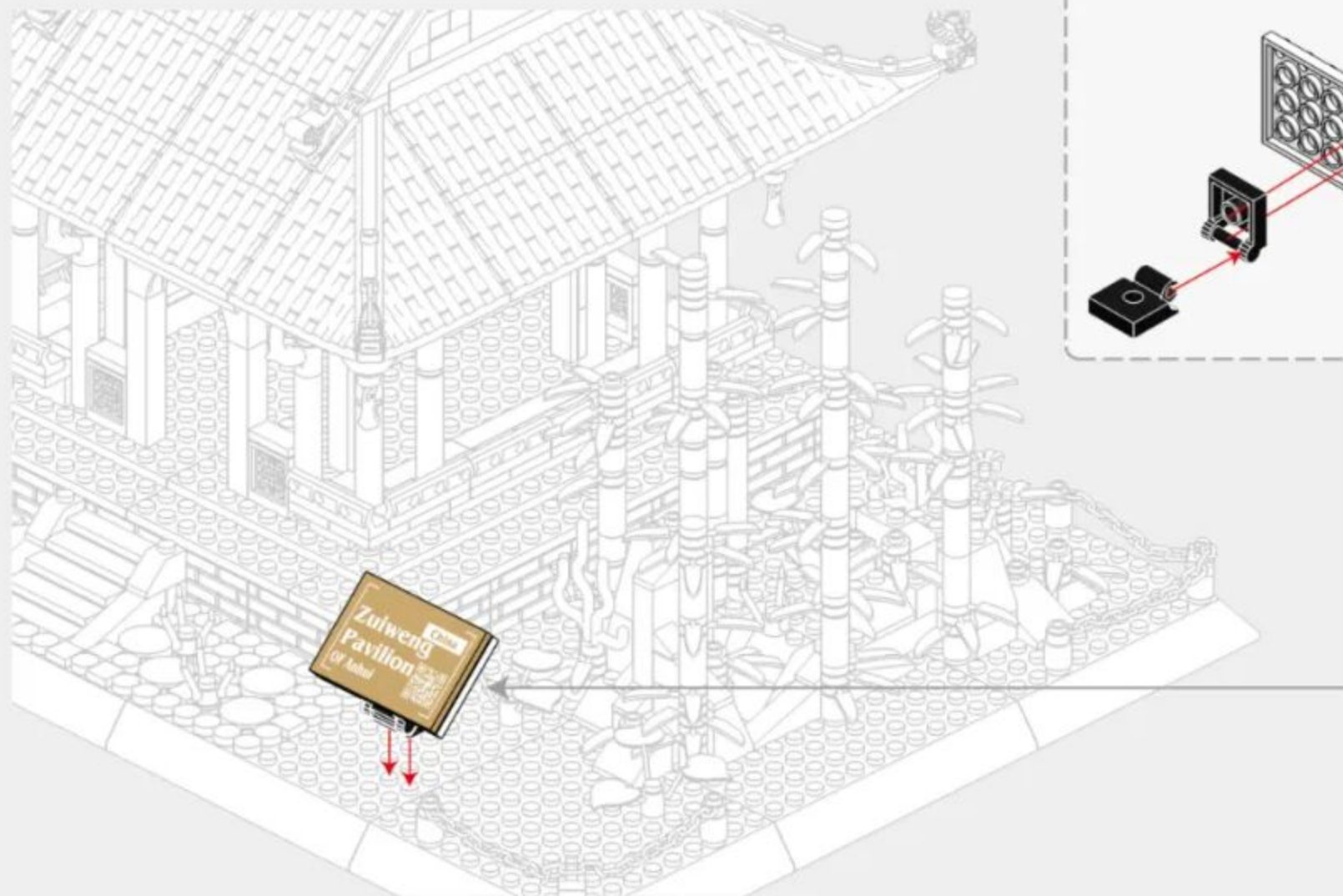
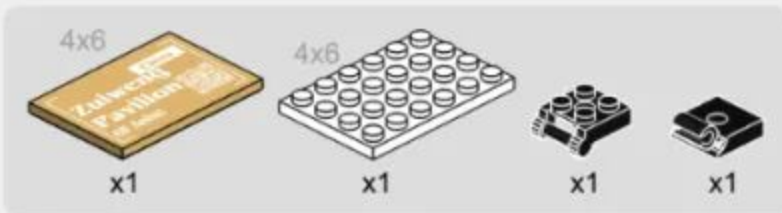



# ARCHITECTURE

The World's great architecture

Shaping Skills   Imagination & Curiosity   Mathematical   Self Discovery & Perception   Parent-Child Interaction   Problem Solving   Creativity



**6224 英国伦敦白金汉宫**  
BUCKINGHAM PALACE-LONDON,ENGLAND



**5225 意大利罗马斗兽场**  
COLOSSEUM-ROME,ITALY



**5226 日本东京帝国饭店**  
IMPERIAL HOTEL-TOKYO,JAPAN



**6211 德国柏林勃兰登堡门**  
BRANDENBURG GATE-BERLIN, GERMANY



**6222 中国甘肃长城-嘉峪关**  
JIAYU PASS-GANSU,CHINA



**6212 日本京都清水寺仁王门**  
NIOMON GATE OF KIYOMIZU-DERA-KYOTO,JAPAN



**6214 中国武汉黄鹤楼**  
YELLOW CRANE TOWER-WUHAN,CHINA



**6215 英国伦敦眼**  
LONDON EYE-LONDON,ENGLAND



**6221 中国北京故宫-太和殿**  
HALL OF SUPREME HARMONY-BEIJING,CHINA



**6213 俄罗斯莫斯科瓦西里大教堂**  
SAINT BASIL'S CATHEDRAL-MOSCOW,RUSSIA



**6220 沙特阿拉伯麦加大清真寺**  
GREAT MOSQUE OF MECCA,SAUDI ARABIA



**6219 美国纽约联合国大厦**  
UNITED NATIONS HEADQUARTERS-NEW YORK,AMERICA



**4214 美国华盛顿白宫**  
WHITE HOUSE-WASHINGTON D.C.,AMERICA



**4212 意大利罗马许愿池**  
TREVİ FOUNTAIN-ROME,ITALY



**4213 法国巴黎卢浮宫**  
MUSÉE DU LOUVRE-PARIS,FRANCE



**4218 新加坡-鱼尾狮**  
MERLION,SINGAPORE



**4210 埃及开罗吉萨金字塔**  
GREAT PYRAMID OF GIZA-CAIRO,EGYPT



**4219 英国伦敦双子塔桥**  
TOWER BRIDGE-LONDON,ENGLAND



**4216 美国华盛顿林肯纪念堂**  
LINCOLN MEMORIAL-WASHINGTON D.C.,AMERICA



**4217 新加坡-金沙酒店**  
MARINA BAY SANDS,SINGAPORE



**7210 中国上海世博会中国馆**  
CHINA PAVILION AT EXPO-SHANGHAI, CHINA



**4221 加拿大渥太华国会山庄**  
PARLIAMENT BUILDINGS-OTTAWA, CANADA



**4211 英国伦敦伊丽莎白塔**  
ELIZABETH TOWER-ENGLAND



**4220 美国纽约熨斗大厦**  
FLATIRON BUILDING-NEW YORK, AMERICA



**5227 美国纽约自由女神像**  
STATUE OF LIBERTY-NEW YORK, AMERICA



**4215 加拿大多伦多电视塔**  
THE CN TOWER-CANADA



**4222 阿联酋迪拜哈利法塔**  
THE BURJ KHALIFA TOWER-DUBAI, UAE



**5224 中国上海东方明珠广播电视塔**  
ORIENTAL PEARL TOWER-SHANGHAI, CHINA



**5212 美国纽约帝国大厦**  
EMPIRE STATE BUILDING-NEW YORK, AMERICA



**5213 马来西亚吉隆坡石油双塔**  
PETRONAS TWIN TOWERS-KUALA LUMPUR, MALAYSIA



**5214 意大利托斯卡纳比萨斜塔**  
LEANING TOWER OF PISA-TUSCANY, ITALY



**5216 英国伦敦伊丽莎白塔**  
ELIZABETH TOWER LONDON ENGLAND



**5219 俄罗斯莫斯科克里姆林宫钟楼**  
SPASSKAYA TOWER-MOSCOW, RUSSIA



**5220 阿联酋迪拜卓美亚帆船酒店**  
BURJ AL ARAB HOTEL-DUBAI, UAE



**5217 法国巴黎埃菲尔铁塔**  
EIFFEL TOWER-PARIS, FRANCE



**5221 中国台北101大楼**  
TAIPEI 101-TAIPEI, CHINA



**6223 中国武汉长江大桥**  
WUHAN YANGTZE RIVER BRIDGE



**5210 法国巴黎圣母院大教堂**  
CATHÉDRALE NOTRE DAME DE PARIS-PARIS,FRANCE



**5223 法国巴黎凯旋门**  
ARC DE TRIOMPHE-PARIS,FRANCE



**5211 印度阿格拉泰姬陵**  
TAJ MAHAL-AGRA,INDIA



**5215 英国伦敦双子塔桥**  
TOWER BRIDGE-LONDON,ENGLAND



**5222 中国北京天坛祈年殿**  
HALL OF PRAYER FOR GOOD HARVESTS-BEIJING,CHINA



**6210 美国旧金山金门大桥**  
GOLDEN GATE BRIDGE-SAN FRANCISCO,AMERICA



**6216 中国北京万里长城（八达岭）**  
THE GREAT WALL-BEIJING,CHINA



**5218 中国北京天安门**  
TIAN'ANMEN TOWER-BEIJING,CHINA



**6217 中国西藏布达拉宫**  
POTALA PALACE-TIBET,CHINA



**6218 芬兰罗瓦涅米圣诞老人办公室**  
SANTA CLAUS OFFICE-ROVANIEMI,FINLAND



**6225 墨西哥库库尔坎玛雅金字塔**  
EL CASTILLO-KUKULKAN,MEXICO



**6226 德国巴伐利亚新天鹅堡**  
SCHLOSS NEUSCHWANSTEIN, BAYERN, DEUTSCHLAND



**5228 美国芝加哥威利斯大厦**  
WILLIS TOWER-CHICAGO, AMERICA



**5229 土耳其伊斯坦布尔其少女塔**  
MAIDEN TOWER-ISTANBUL,TURKEY



**5230 中国湖南长沙爱晚亭**  
AIWAN TING PAVILION-HUNAN,CHINA



**5231** 巴西里约热内卢救世基督像  
CRISTO REDENTOR-RIO DE JANEIRO, BRASIL



**5232** 美国宾夕法尼亚州流水别墅  
FALLINGWATER-PENNSYLVANIA, AMERICA



**5233** 美国芝加哥范斯沃斯住宅  
FARNSWORTH HOUSE-CHICAGO, AMERICA



**5234** 美国华盛顿唐人街  
CHINA TOWN-WASHINGTON, D.C., AMERICA



**3210** 美国纽约自由女神像  
STATUE OF LIBERTY-NEW YORK, AMERICA



**4223** 中国北京清华园  
TSINGHUA CAMPUS-BEIJING, CHINA



**7211** 中国湖南岳阳楼  
YUEYANG TOWER-HUNAN, CHINA



**8210** 澳大利亚悉尼歌剧院  
SYDNEY OPERA HOUSE-BENNELONG POINT, AUSTRALIA



**7212** 中国江西滕王阁  
PAVILION OF PRINCE TENG-JIANGXI, CHINA



**6227** 中国河南少林寺  
SHAOLIN TEMPLE-HENAN, CHINA



**7213** 中国重庆洪崖洞  
HONGYADONG-CHONGQING, CHINA



**5235** 美国国会大厦  
UNITED STATES CAPITOL-WASHINGTON, D.C., AMERICA



**5236** 中国安徽醉翁亭  
ZUIWENG PAVILION-ANHUI, CHINA

# ZUIWENG PAVILION

COUNTRY: China  
CITY: Anhui



Ver.5236220528