

VILLA SAVOYE

VILLA SAVOYE

Paris, France

The world's great architecture



6+ / 5237 / 1226PCS
Suitable Age / Product Number / Parts Total



Architecture

It will be a city...

这将构成一座城市...

ABOUT THE PRODUCT

关于产品



ARCHITECTURE

WANGE The world's great architect since 1991

Villa Savoye



Villa Savoye is a modernist villa and gatelodge in Poissy, on the outskirts of Paris, France.



Villa Savoye



Geography and culture

地理.文化



As an exemplar of Le Corbusier's "five points" for new constructions, the villa is representative of the origins of modern architecture and is one of the most easily recognizable and renowned examples of the International style.





Villa Savoye

Villa Savoye

France

The contents of this chapter refer to the Wikipedia website.

本章内容参考维基百科网站，更多资讯可自行查阅。

The world's great architecture

Buildings and layout

■ 建筑物和布局



Villa Savoye is a modernist villa and gatelodge in Poissy, on the outskirts of Paris, France. It was designed by the Swiss architects Le Corbusier and his cousin Pierre Jeanneret, and built between 1928 and 1931 using reinforced concrete. As an exemplar of Le Corbusier's "five points" for new constructions, the villa is representative of the origins of modern architecture and is one of the most easily recognizable and renowned examples of the International style.

La Villa Savoye es un edificio situado en Poissy, a las afueras de París, que fue construido en 1929 y proyectado por Le Corbusier, uno de los arquitectos más influyentes del siglo XX. La Villa Savoye es considerada como el paradigma de la Arquitectura Internacional y de la nueva manera de construir edificios de viviendas del siglo XX (junto con la Casa Farnsworth de Ludwig Mies van der Rohe, la Casa de la Cascada de Frank Lloyd Wright, Casa Sobre el Arroyo de Amancio Willams y Delfina Gálvez y la Villa Mairea de Alvar Aalto y Aino Marsio), así como de los Cinco Puntos para una nueva Arquitectura desarrollados por el propio Le Corbusier, que consisten en: Edificio que descansa sobre pilotes (columnas) en la planta baja, dejando la superficie en su mayoría libre para permitir que el paisaje quede autónomo del edificio. Cubierta en terraza, sobre la que se sitúa un jardín.



Construction

The project was tendered in February, with contracts being awarded in March 1929. Changes made to the design while the project was being built, which included an amendment to the storey height and the removal and reinstatement of the chauffeur's accommodation, led to the costs rising to approximately 900,000 Francs. When the construction of the project started, no design work had been done on the lodge, and the final design was only presented to the client in June 1929.

La parte principal de la vivienda (salón, comedor, cocina, dormitorios y baños) se encuentra ubicada en la primera planta, mientras que la planta baja está ocupada por el hall y dependencias para el servicio, y cuenta con un garaje capaz de contener tres automóviles de la época, algo que fue un hito para la historia de la arquitectura y un gran adelanto para su tiempo. La cubierta es plana y en ella se encuentra un pequeño jardín.



History

Pierre and Eugénie Savoye approached Le Corbusier about building a country home in Poissy in the spring of 1928. The prospective site was a green field on an otherwise wooded plot of land, with a magnificent view of the landscape to the north west that matched the approach to the plot along the road. Other than an initial brief prepared by Emile for a summer house, space for cars, an extra bedroom and a caretaker's lodge, Le Corbusier had such freedom in executing the commission that he was limited only by his own architectural aesthetic. He began work on the project in September 1928. His initial ideas were ultimately manifested in the final building, though between Autumn 1928 and Spring 1929 he drew up a set of alternative designs that were governed primarily by the Savoye couple's concerns regarding cost. The eventual solution to the cost problem was to reduce the volume of the building by moving the master bedroom down to the first floor and reducing the grid spacing from 5 metres to 4.75 metres.

La vivienda fue habitada por sus dueños durante un corto espacio de tiempo. El edificio se terminó en 1929, pero tras la invasión alemana de Francia de 1940, fue abandonada y posteriormente bombardeada e incendiada durante la Segunda Guerra Mundial. En 1963 la Villa Savoye fue declarada patrimonio arquitectónico por parte del gobierno francés, y se procedió posteriormente a restaurarla, ya que se encontraba en un estado de ruina tras la dejadez y los ataques sufridos en la guerra.

Force Balance

受力平衡

$$F = G \frac{m_1 m_2}{d^2}$$

Physical operations

物理运算

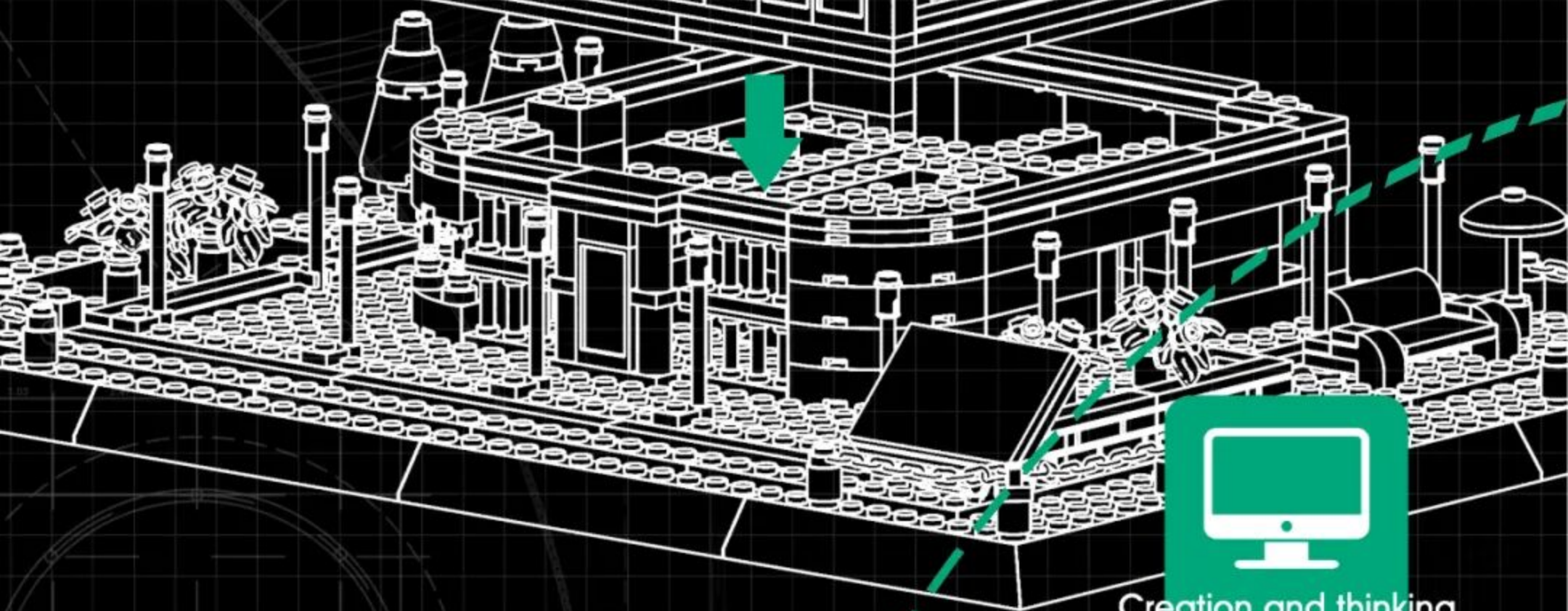
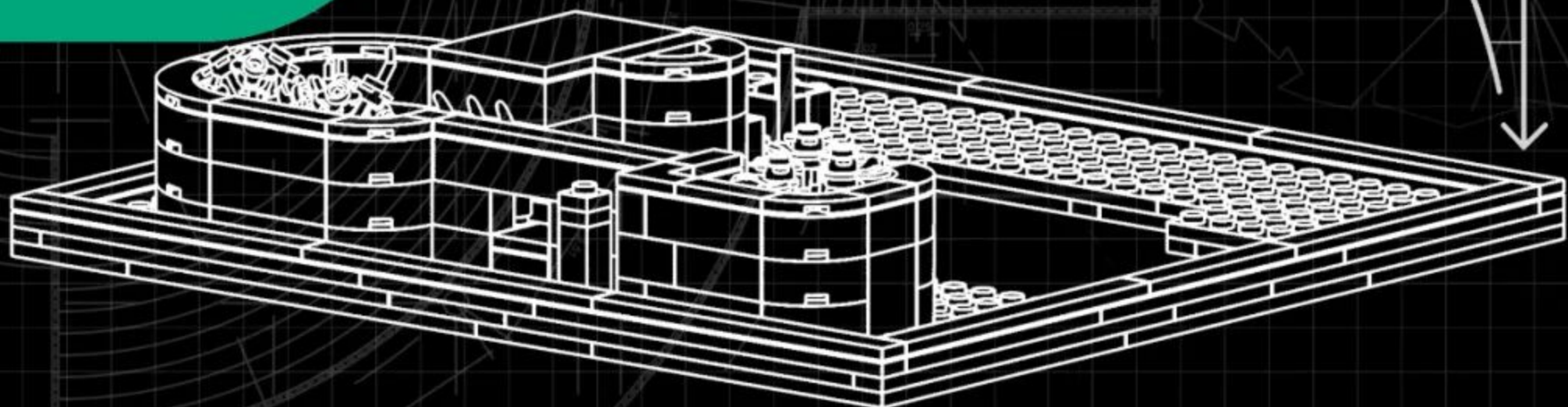

Creation and thinking

创作·思考

08

Special parts

特殊零件的开发利用

$$S=4\pi \cdot r^2$$

$$a^2+b^2=c^2$$



WG1280
四孔墙砖



WG0550
角底板



WG0422
四孔栏杆



WG1218
五倍圆棒

$$\sin^2 a + \cos^2 a = 1$$



features and functions

特点.功能

Main Color Matching

配色方案



Color matching

Adopting 3 main colors, White, light grey and Dark green as the main color, the more reasonable and Black color matching on the original building, making the product more atmospheric and the whole design is more reasonable.

Villa Savoye

法国巴黎普瓦西萨伏伊别墅



Front

Left

Back

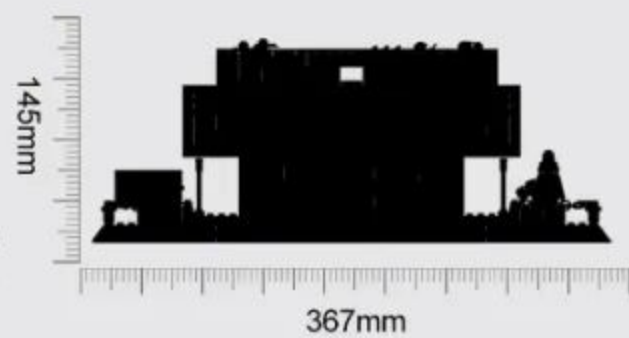
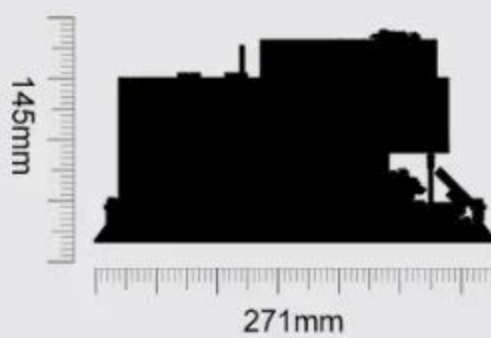
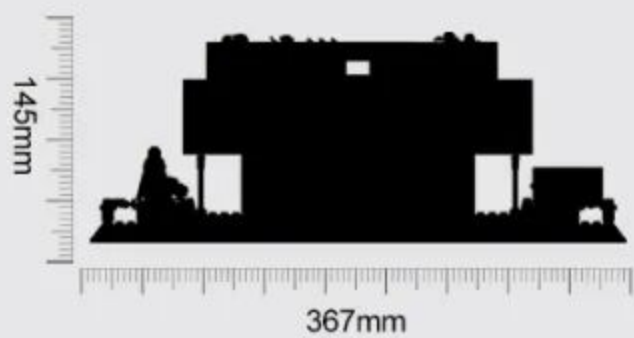

Product Size:367X271X145mm



Instructions For Use

积木起件器使用说明
Brickseparator

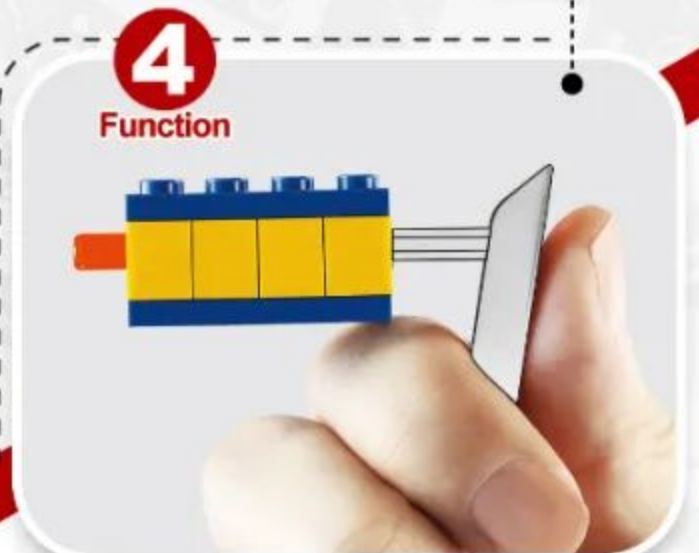
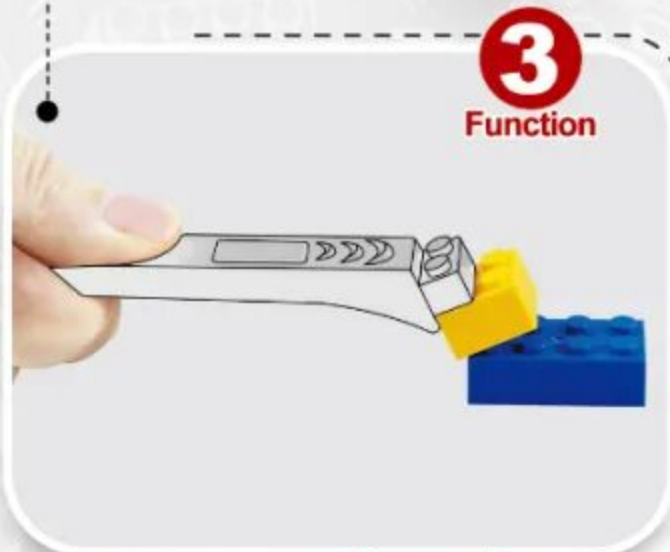
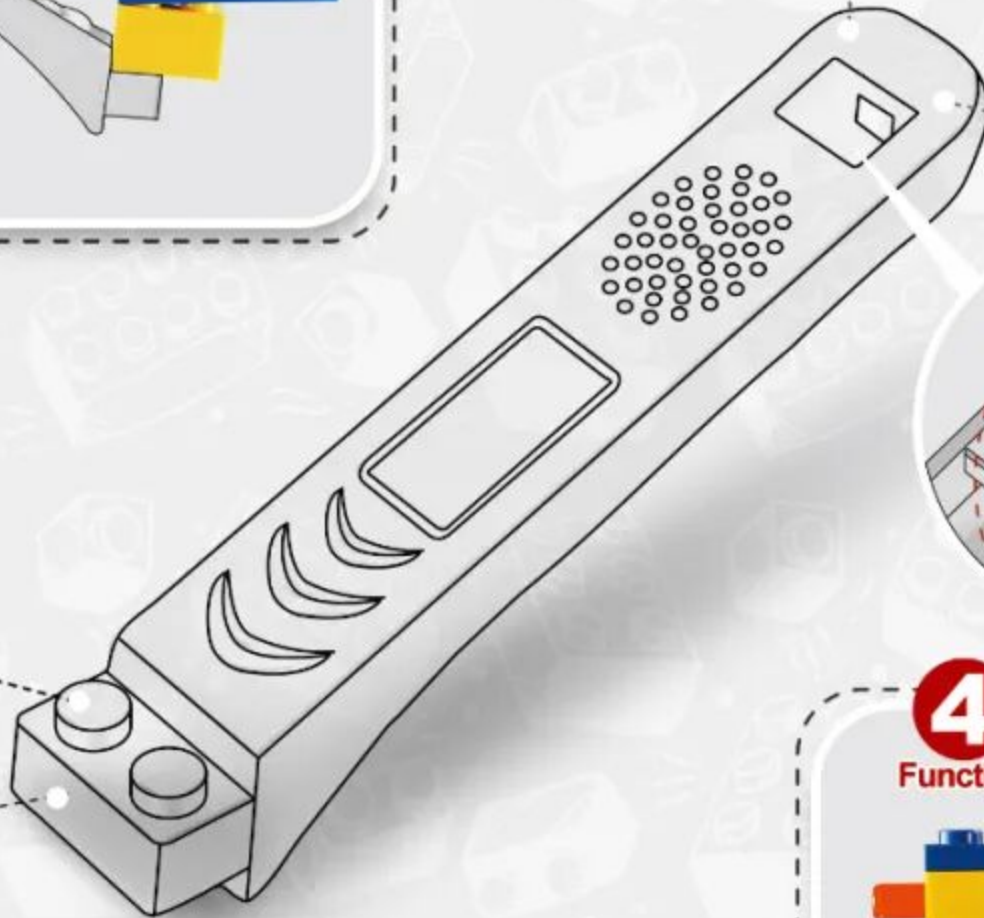
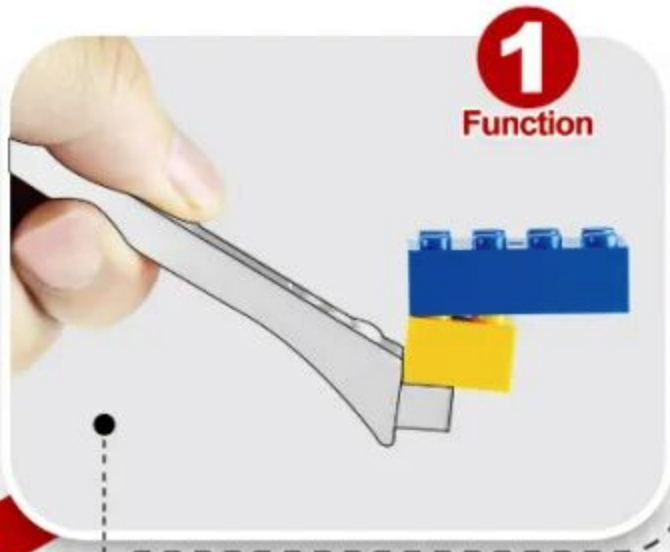

4 ways to make installation easier
让安装更简单



■ First open the product packaging according to the instructions.

按指导用正确方式拆解产品外包装。



■ Summarize all parts to count the number of familiar accessories.

对照说明书清单确认积木包数量与积木数量。



■ Arranging all accessories by color helps to quickly install the product.

把确认好的积木以类型、颜色进行分类排好以便安装。



■ Carefully install the product and learn about building.

按说明书步骤拼装并完成你的积木模型。



1:1 Physical Reference Table

十字棒配件1:1尺寸参照表



Instructions For Use
让安装更简单



2 $(1 \times 2) = 2$

3 $(1 \times 3) = 3$

4 $(1 \times 4) = 4$

5 $(1 \times 5) = 5$

6 $(1 \times 6) = 6$

7 $(1 \times 7) = 7$

8 $(1 \times 8) = 8$

9 $(1 \times 9) = 9$

10 $(1 \times 10) = 10$

12 $(1 \times 12) = 12$

16 $(1 \times 16) = 16$

PARTS LIST

配件清单

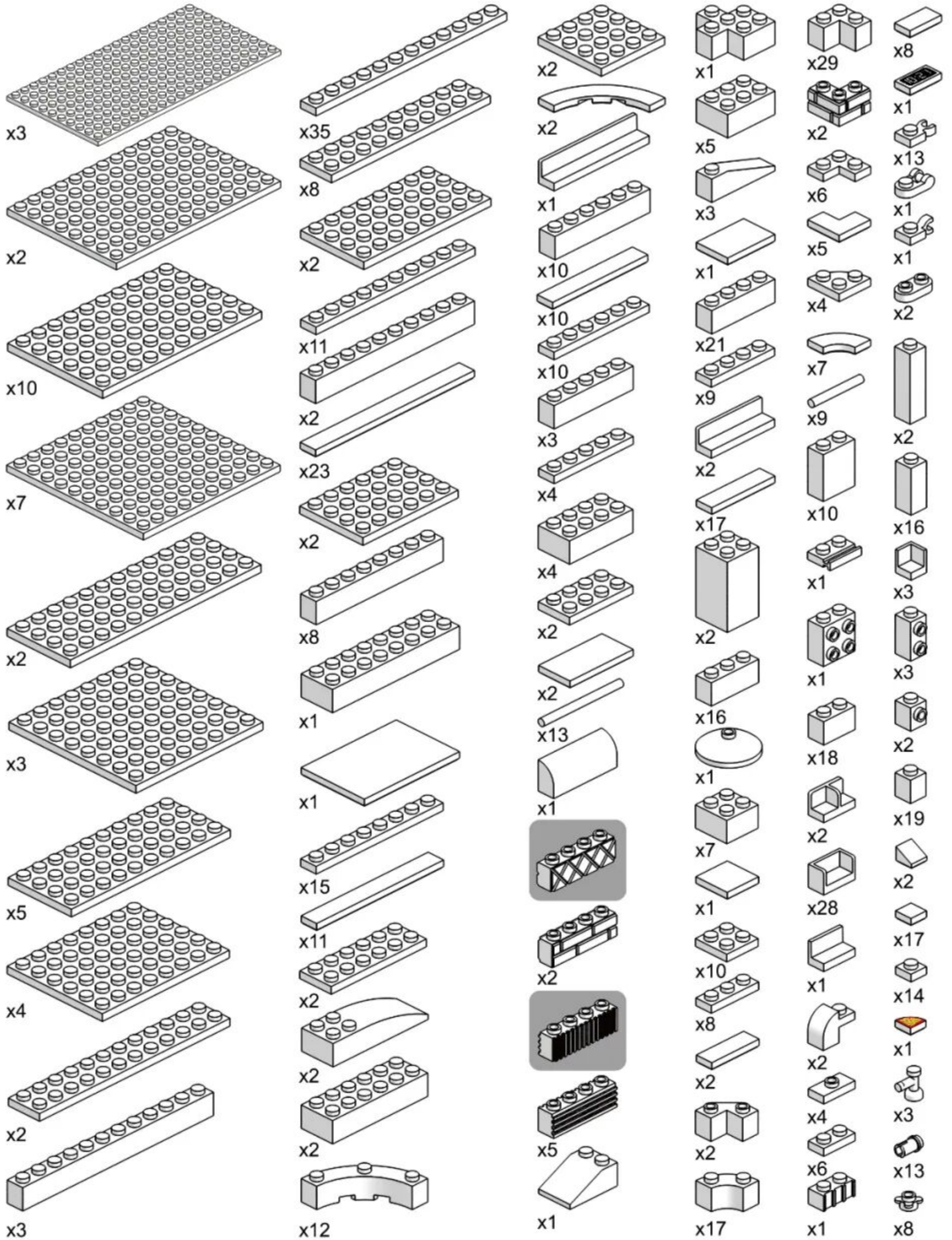







































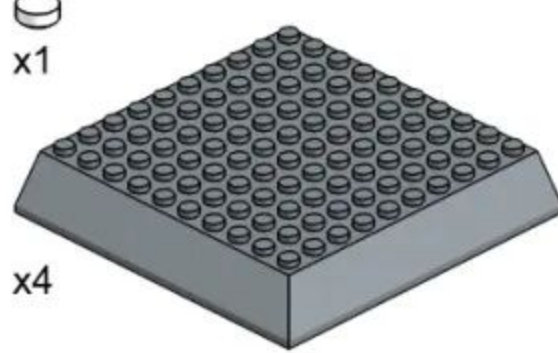







































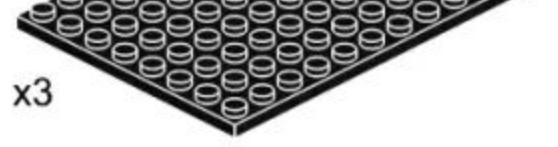





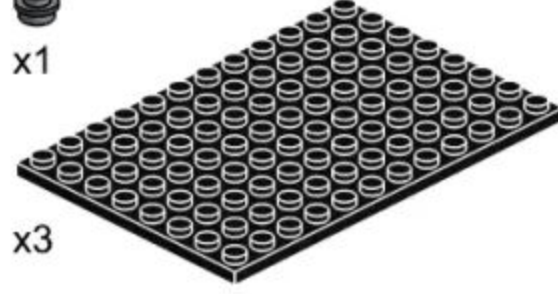





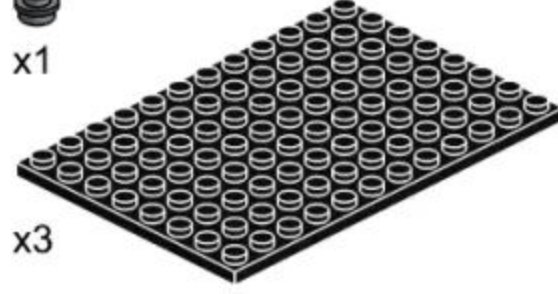



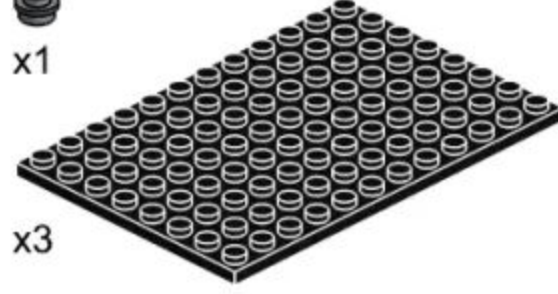

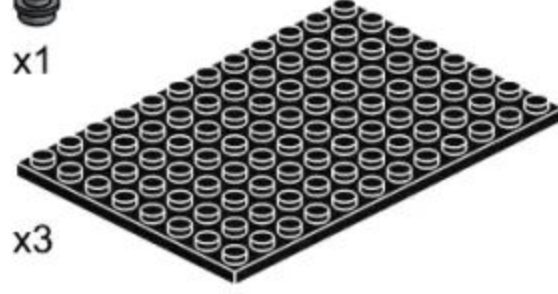



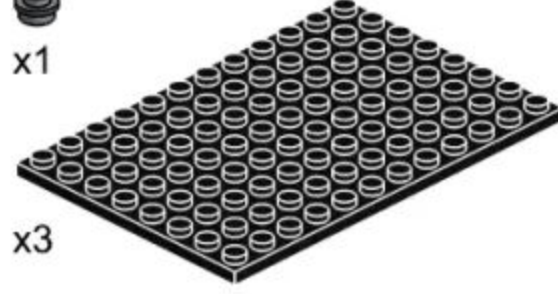

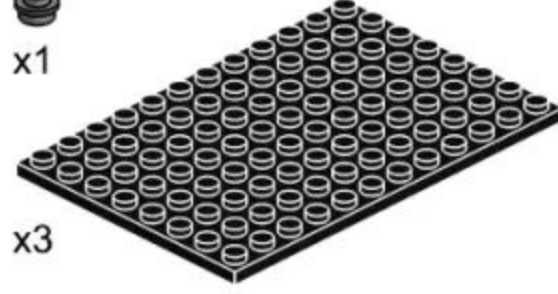

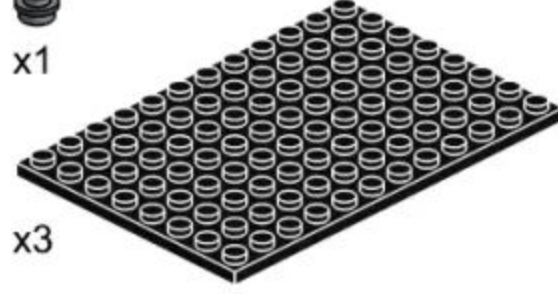

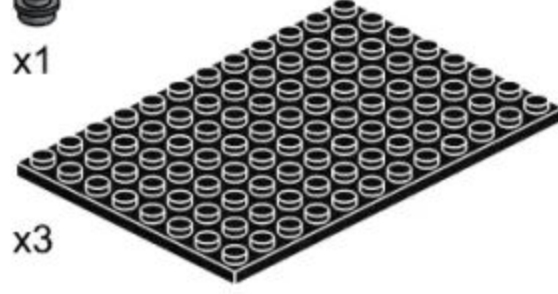

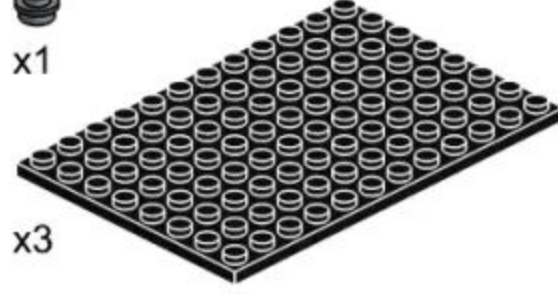

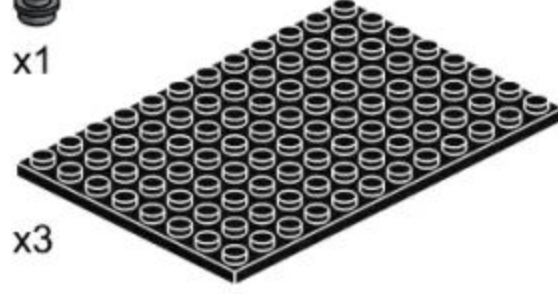

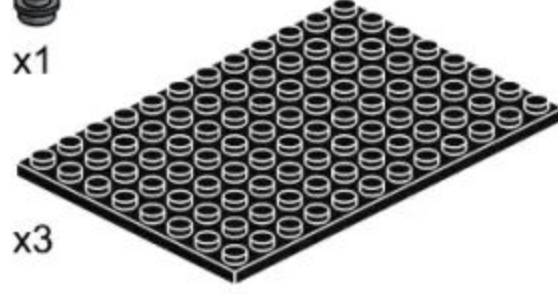

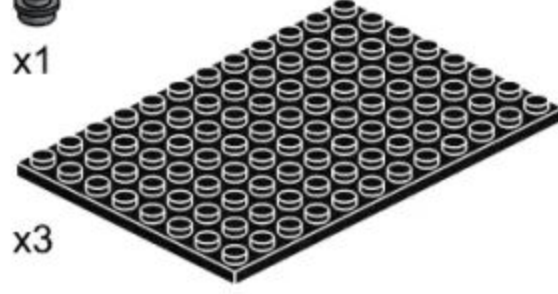

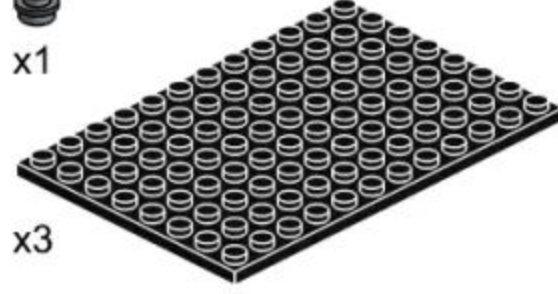

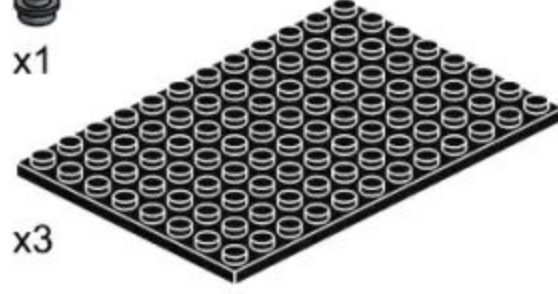

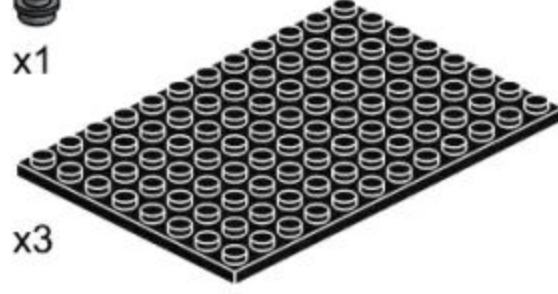

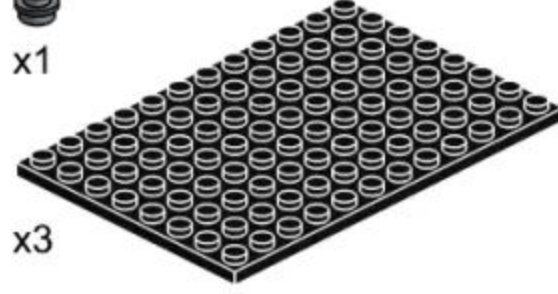

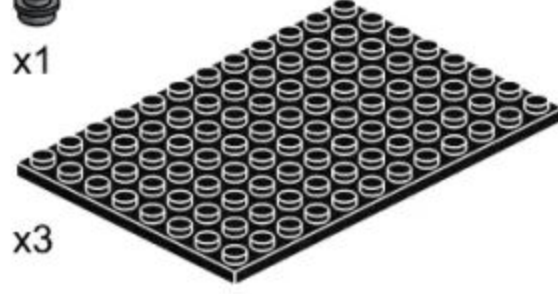

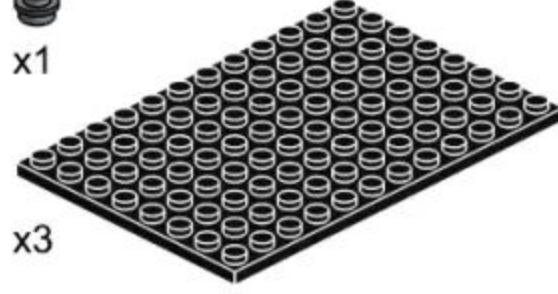

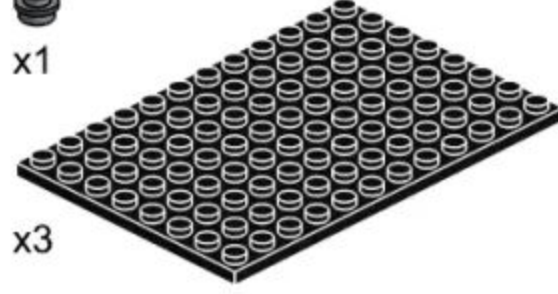

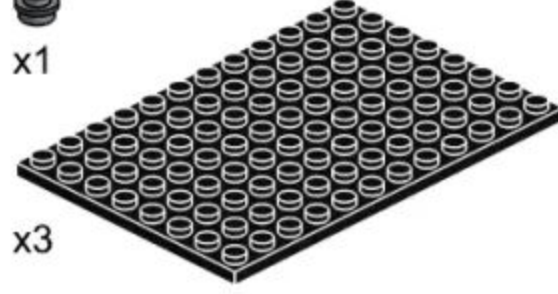

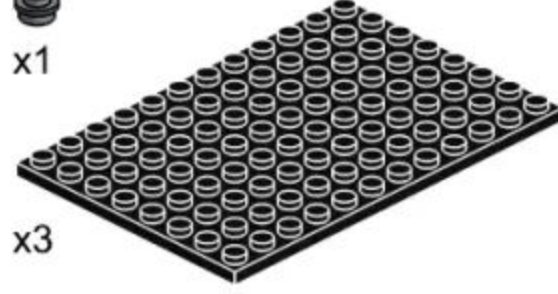

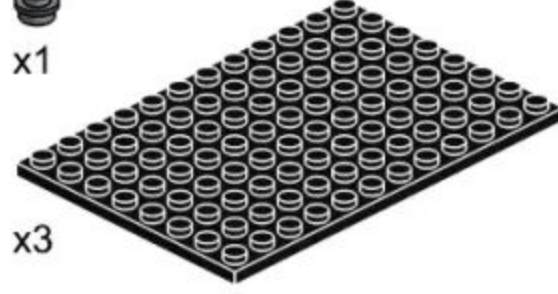

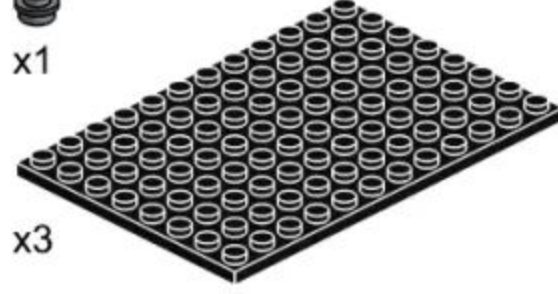

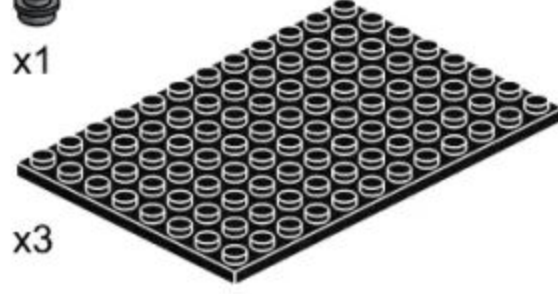

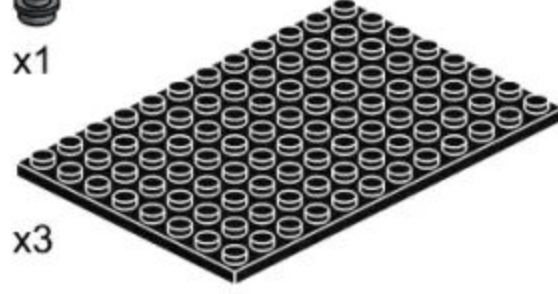

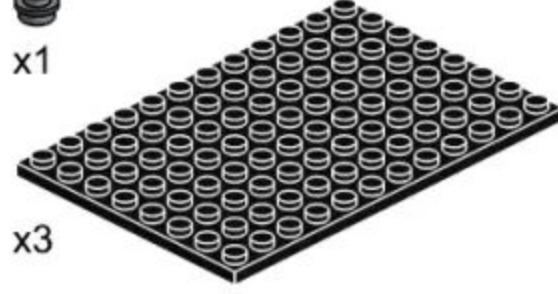

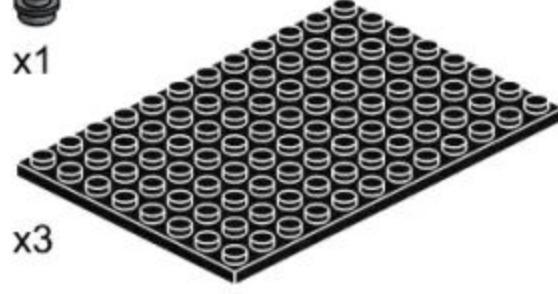

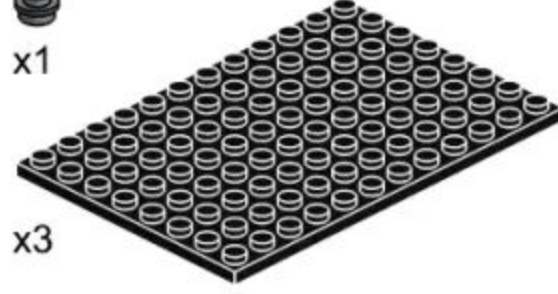

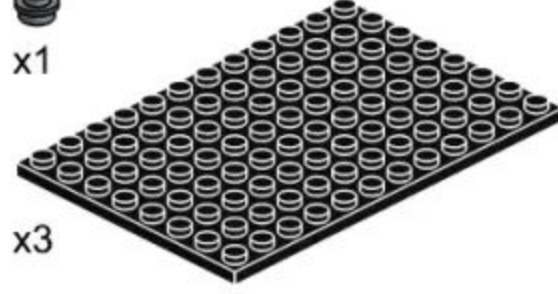

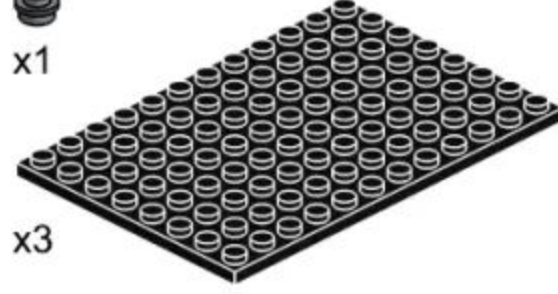

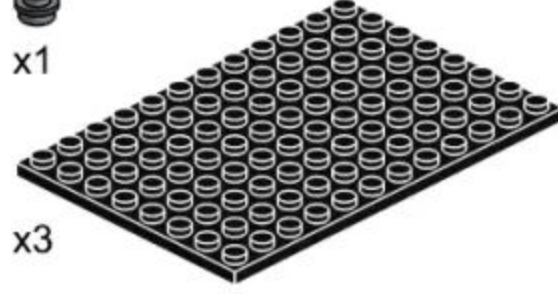

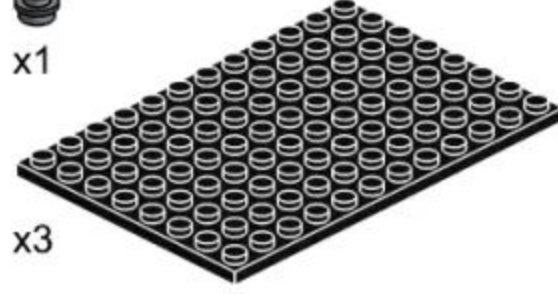

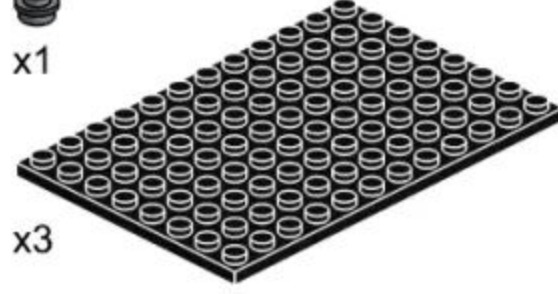

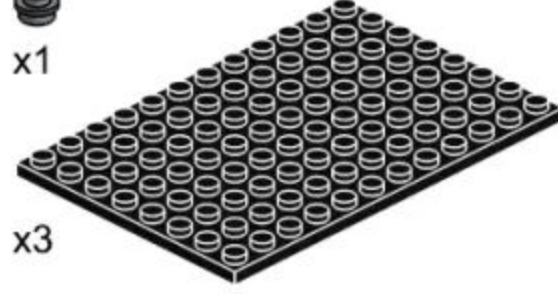

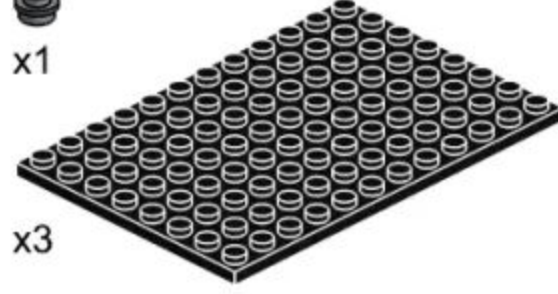

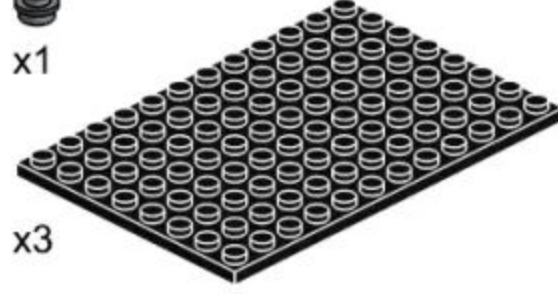

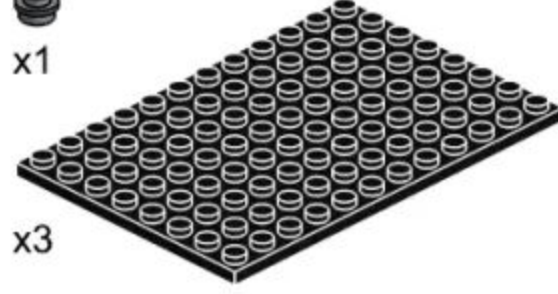

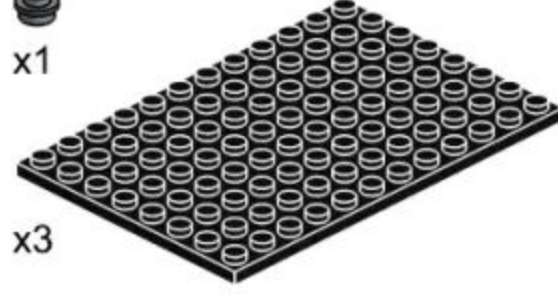

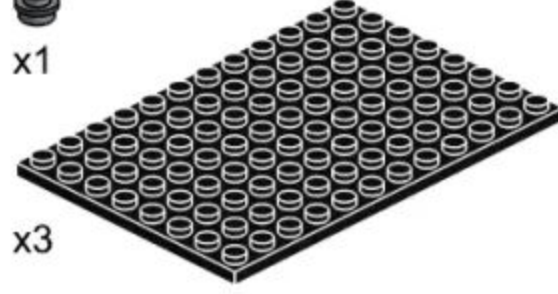

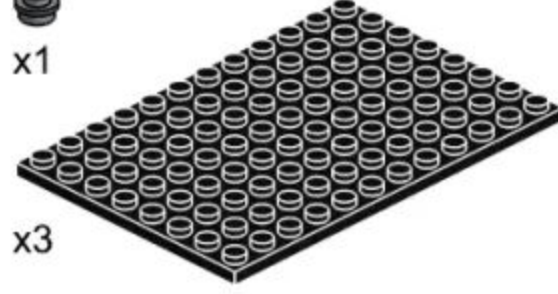

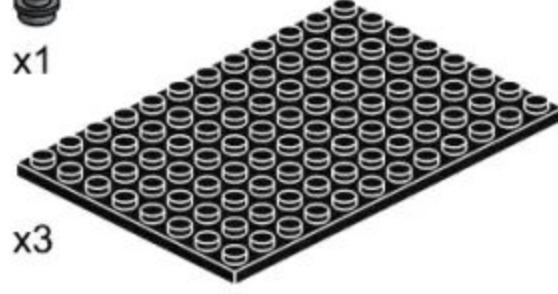

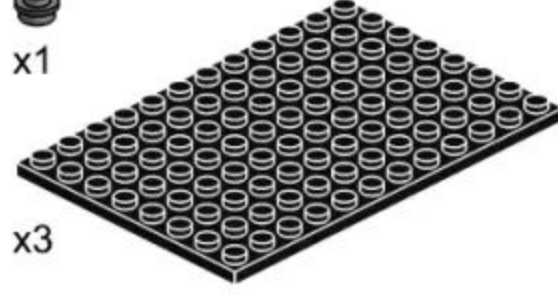

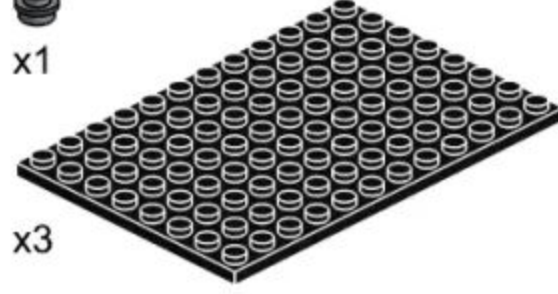

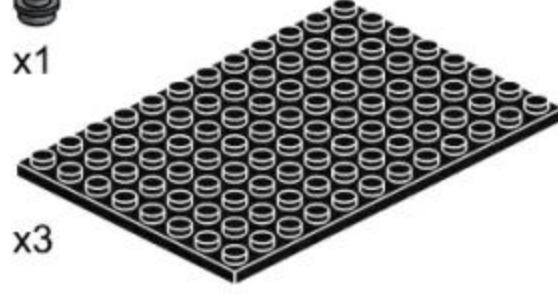

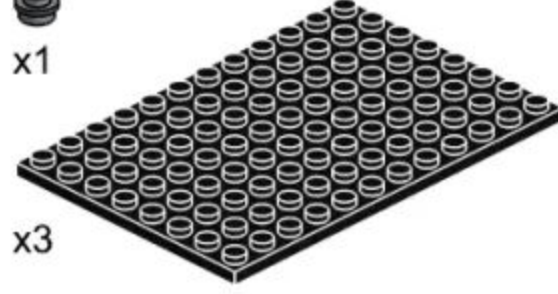

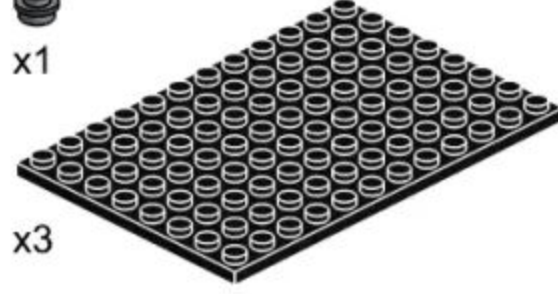

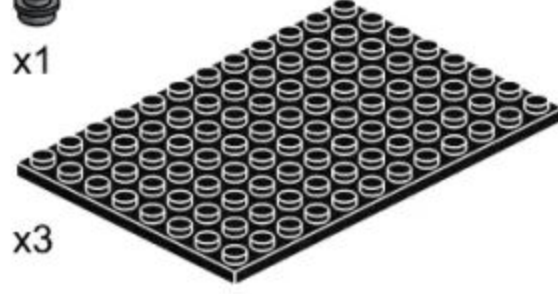

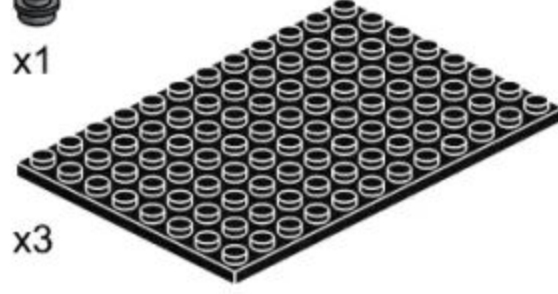

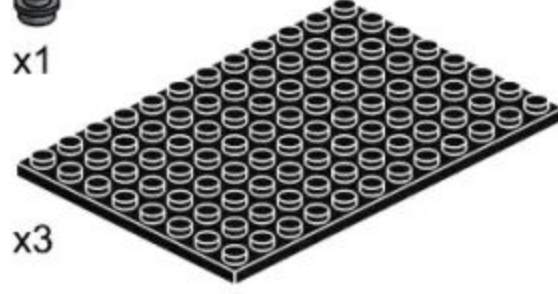

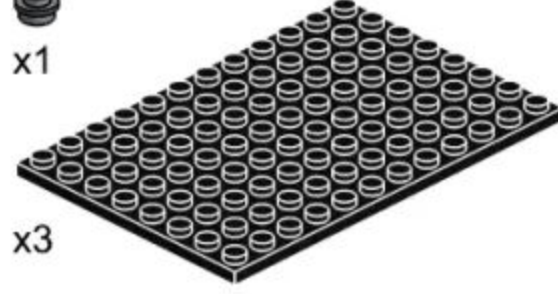

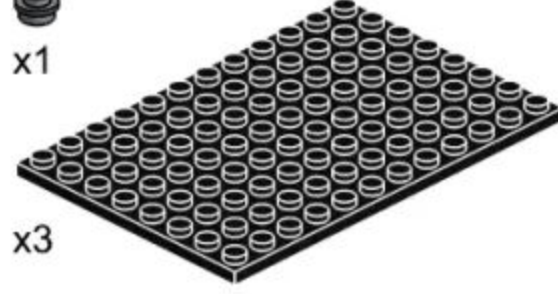

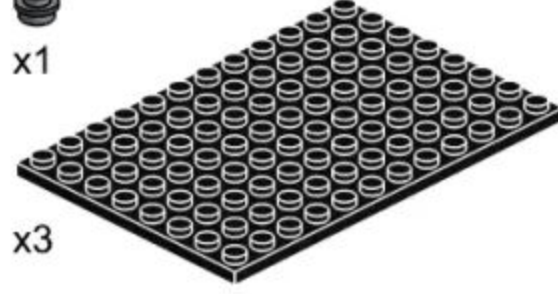

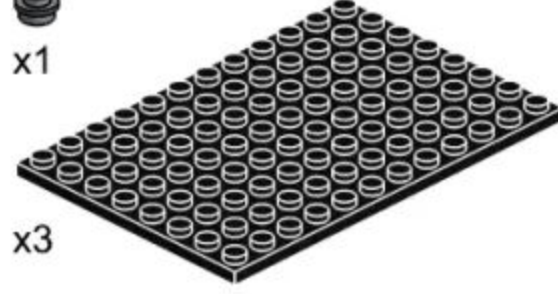

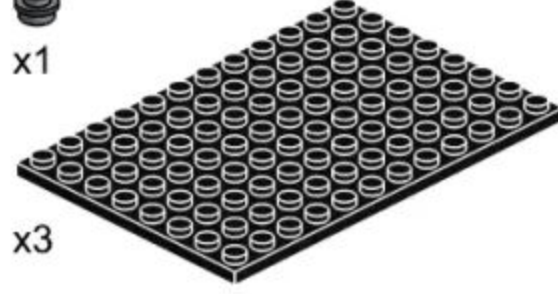

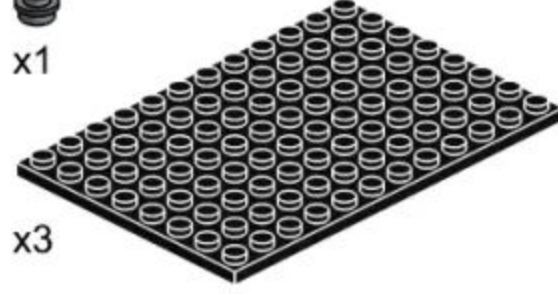

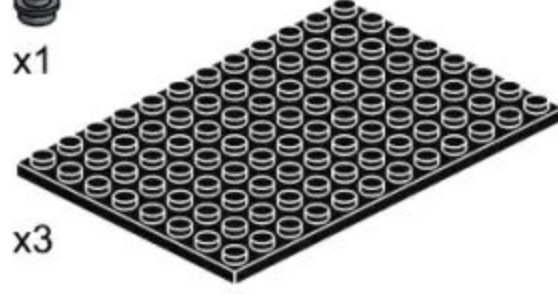
产品有增补件请以实物为准

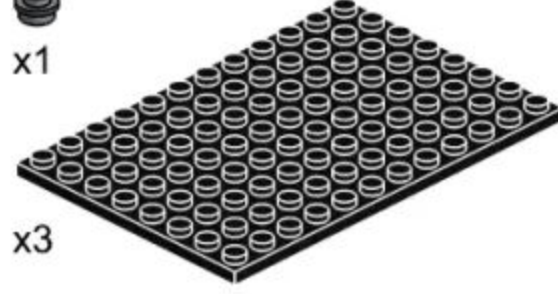
If product has additional parts, please in kind prevail.

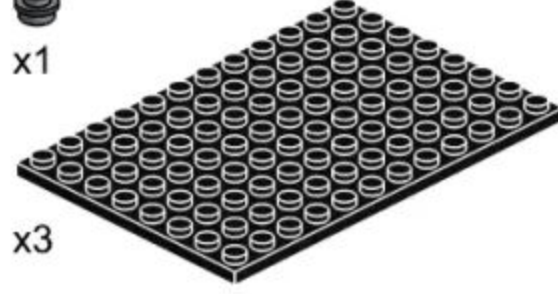
PARTS LIST

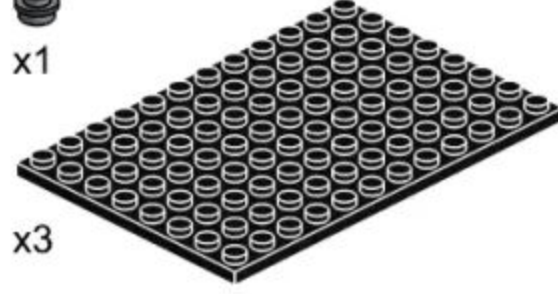
配件清单

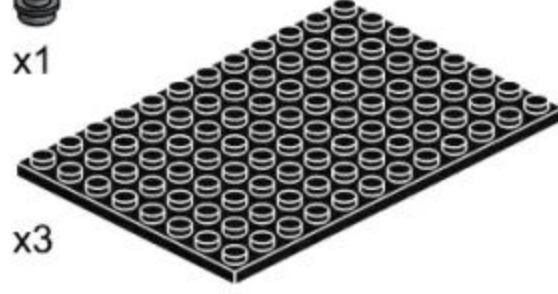
			
x2	x4	x8	x1
			
x8	x3	x1	x1
			
x5	x2	x3	x2
			
x3			
	x5		
x1			
	x1		
x1			
	x1		
x4			x2
	x1		
x6			x2
	x1		
x3			x3
	x40		
x1			x2
	x1		
x2			x8
	x1		
x3			x2
	x36		
	x3		x4
			x3
x12	x2		
			
x1	x3		
			
x3	x2		
			
	x2		
			
	x2		
			
	x2		
			
	x2		
			
	x2		
			
	x2		
			
	x2		
			
	x2		
			
	x2		
			
	x2		
			
	x2		
			
	x2		
			
	x2		
			
	x2		
			
	x2		
			
	x2		
			
	x2		
			
	x2		
			
	x2		
			
	x2		
			
	x2		
			
	x2		
			
	x2		
			
	x2		
			
	x2		
			
	x2		
			
	x2		
			
	x2		
			
	x2		
			



261 PCS

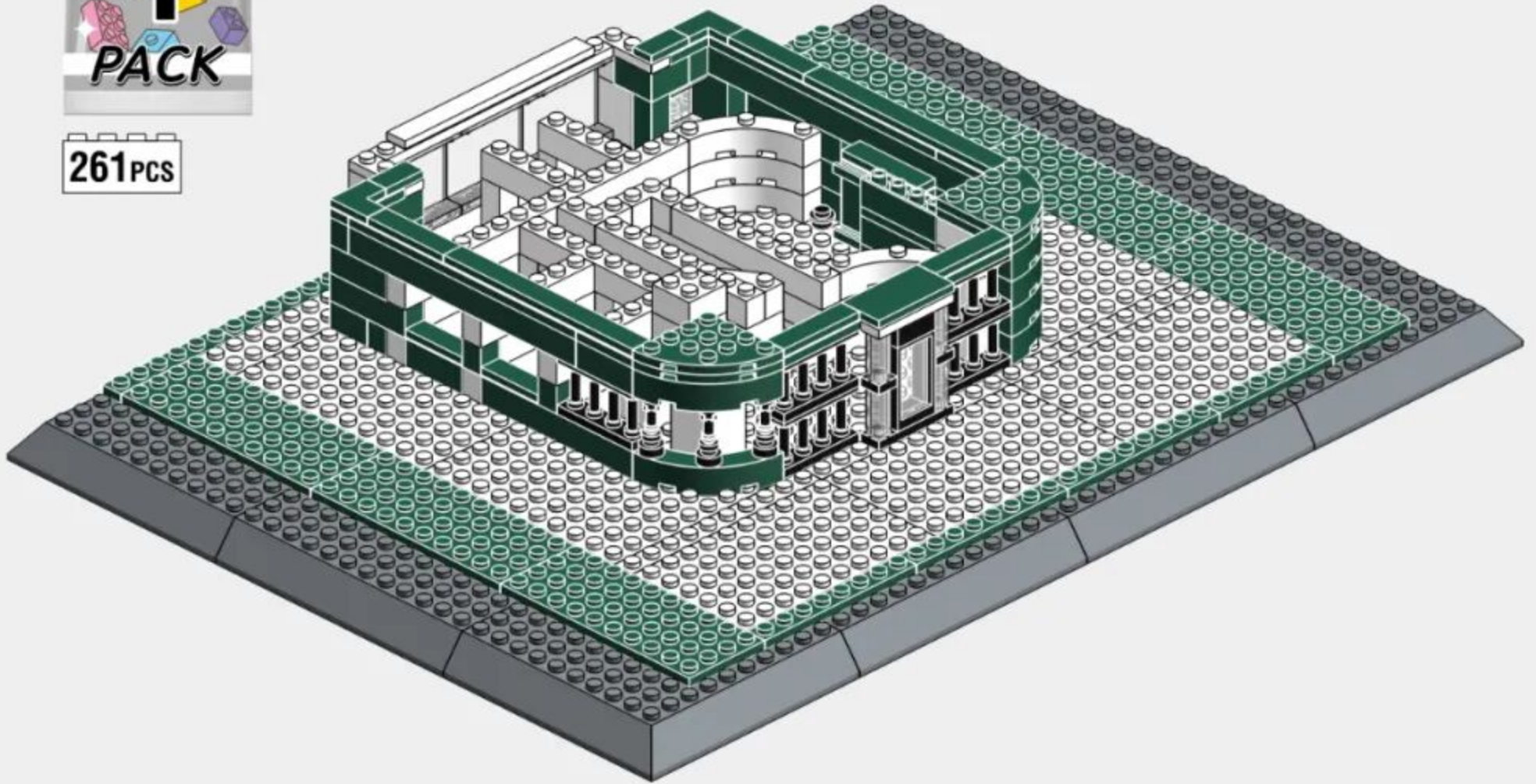

1-1

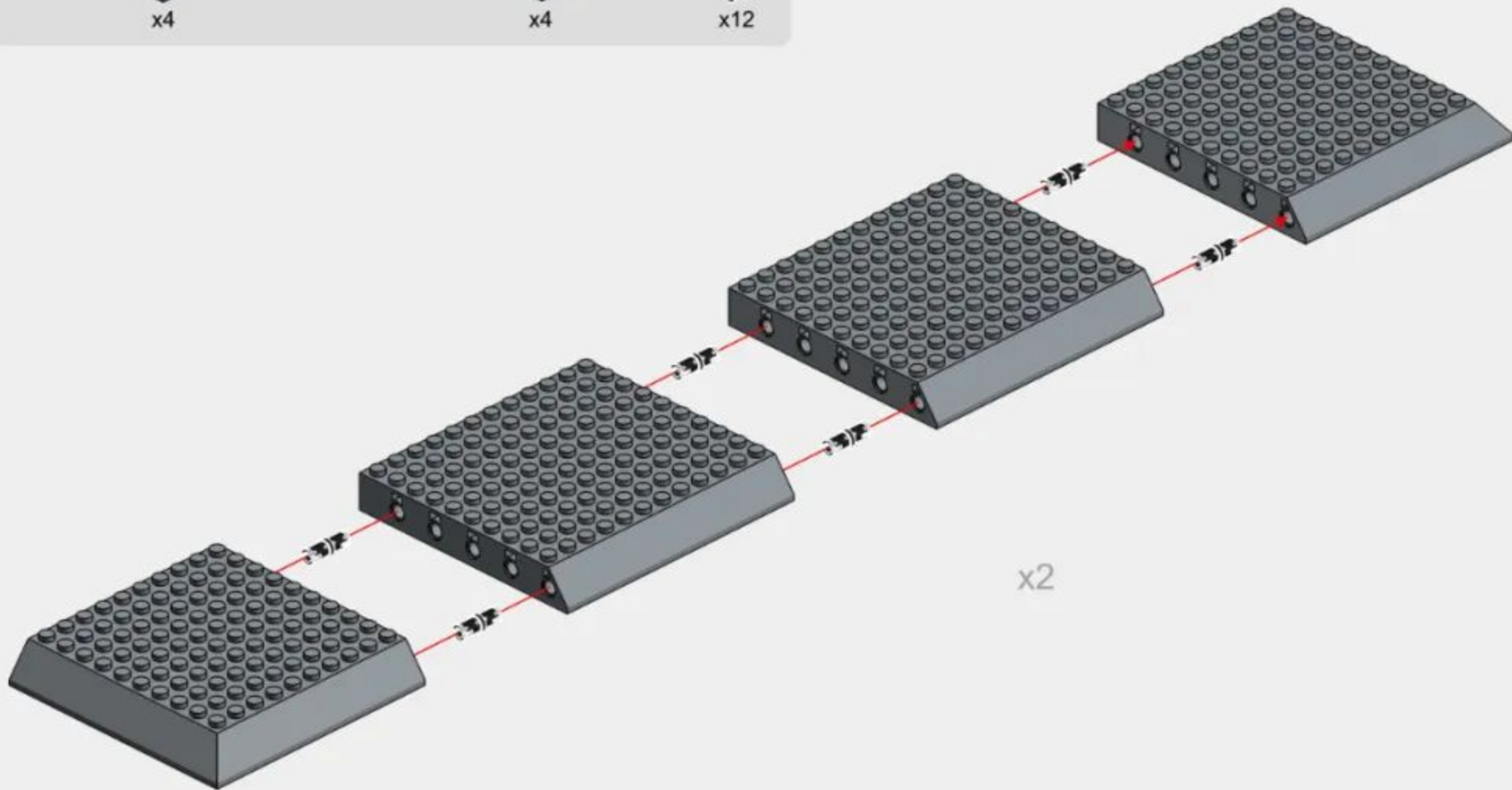
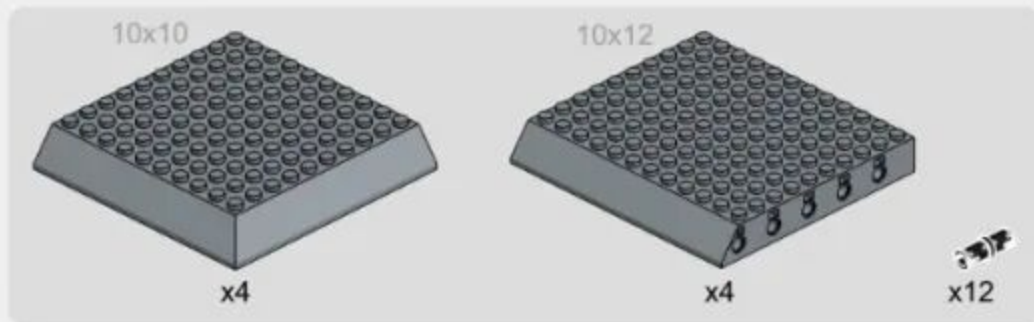

1-2

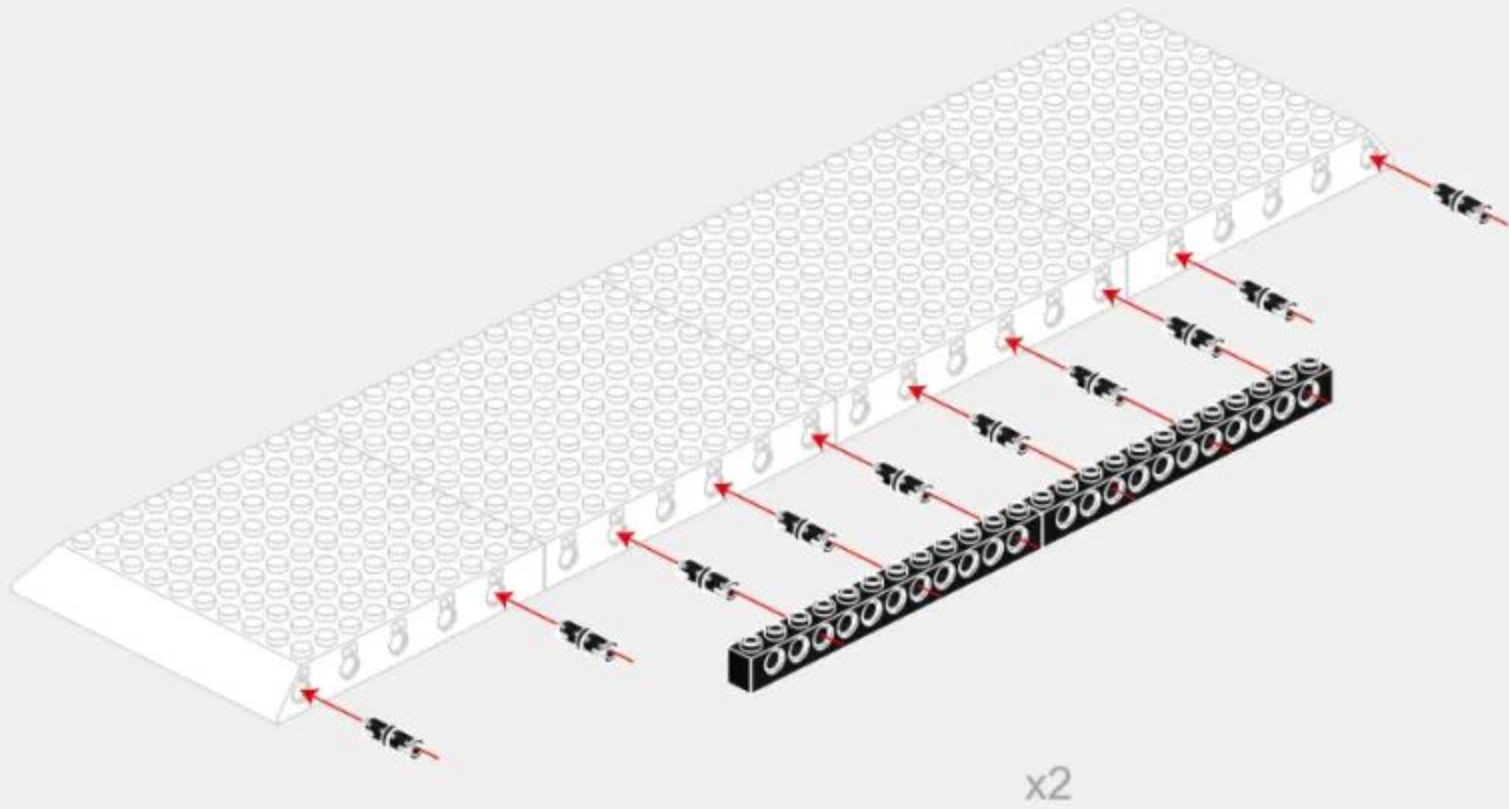
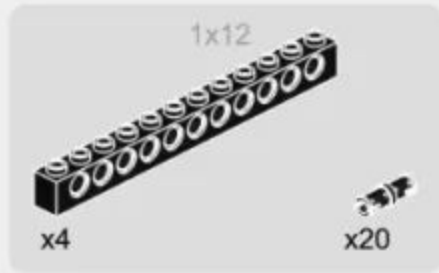

1-3

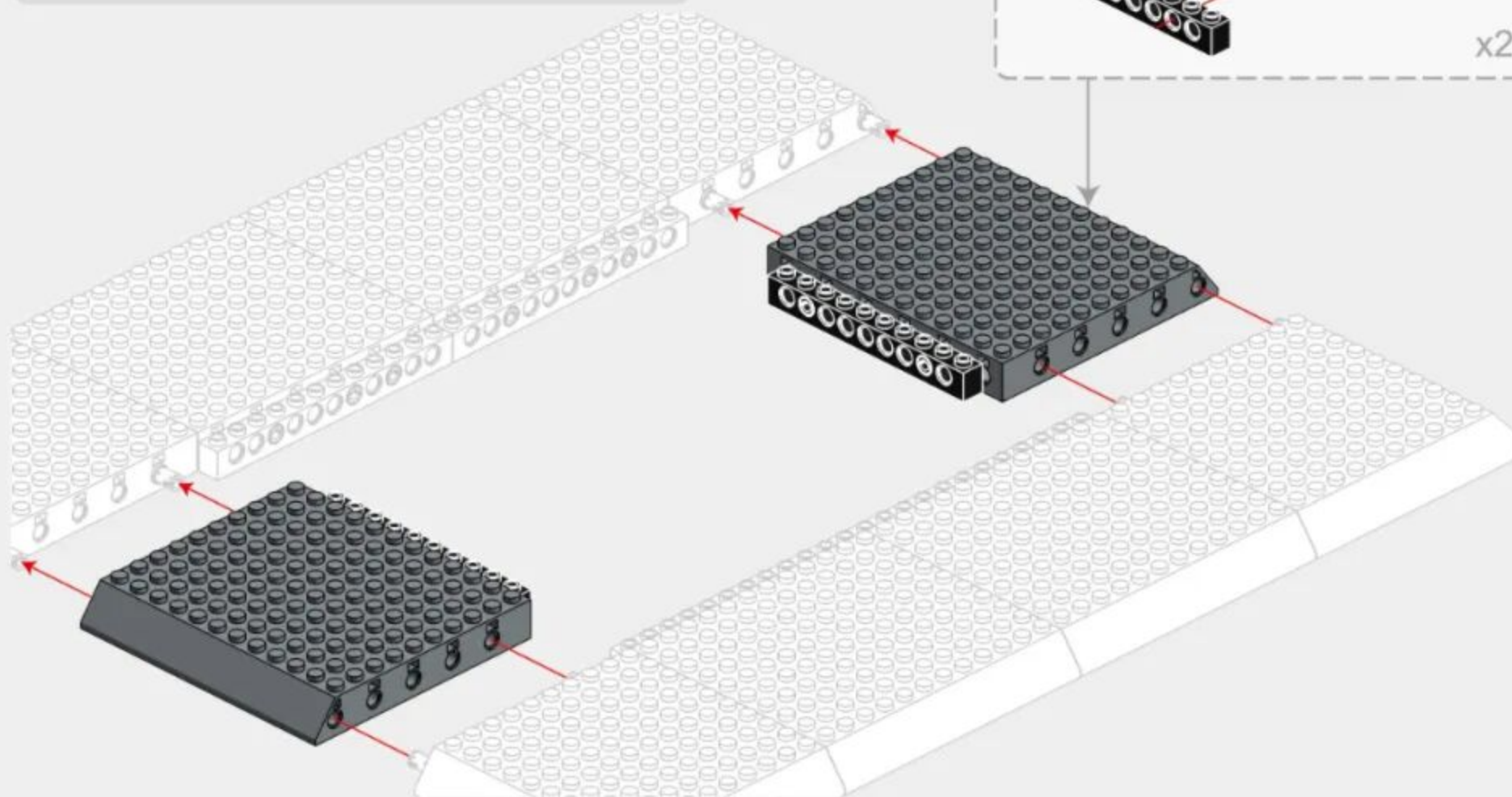
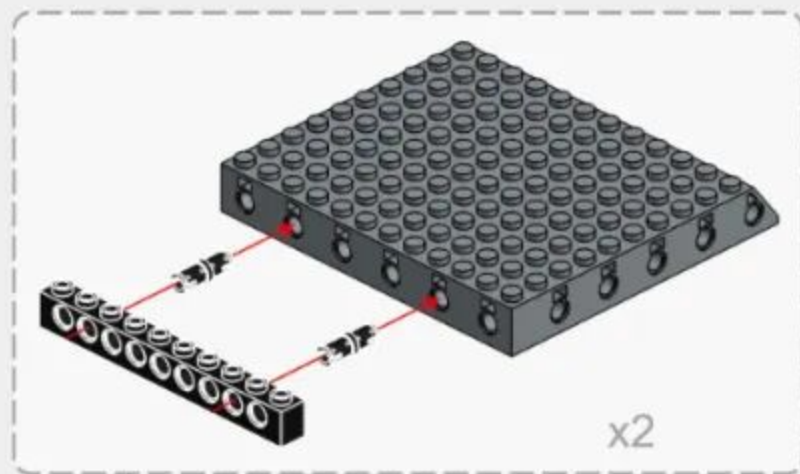
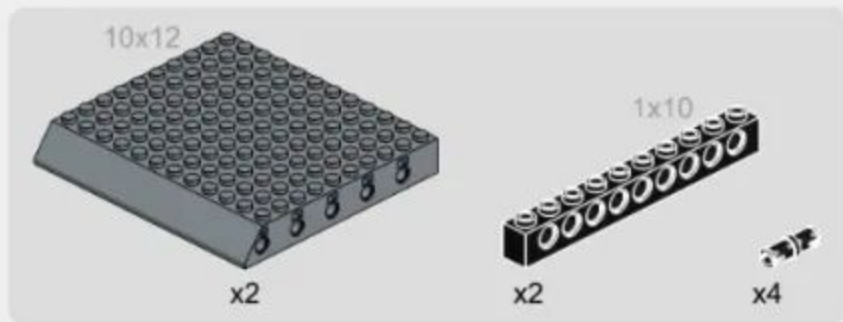

1-4

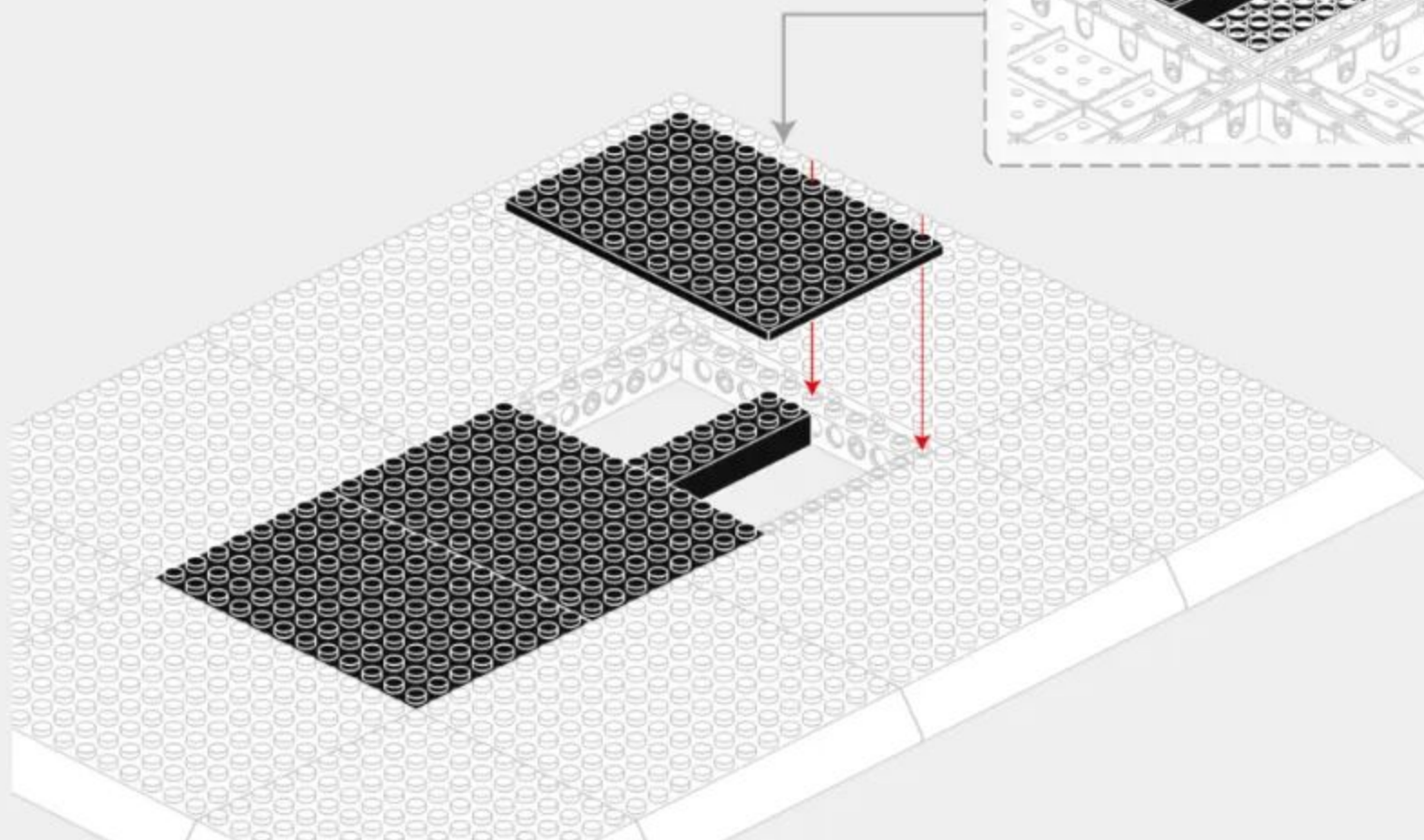
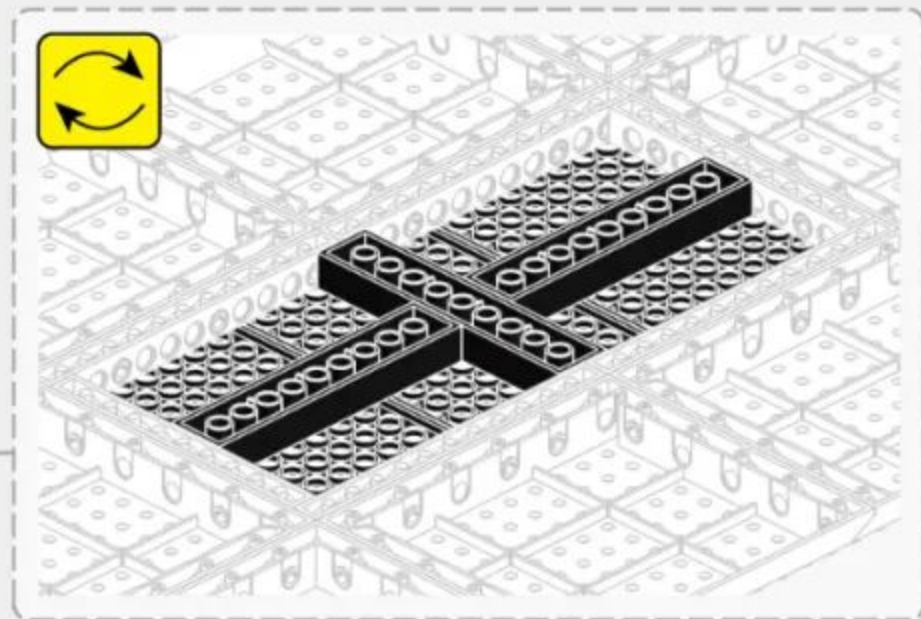
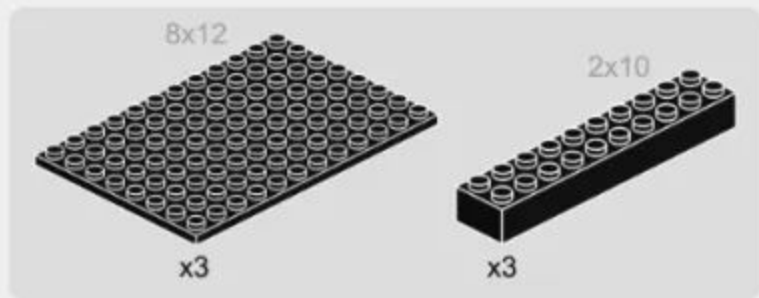

1-5

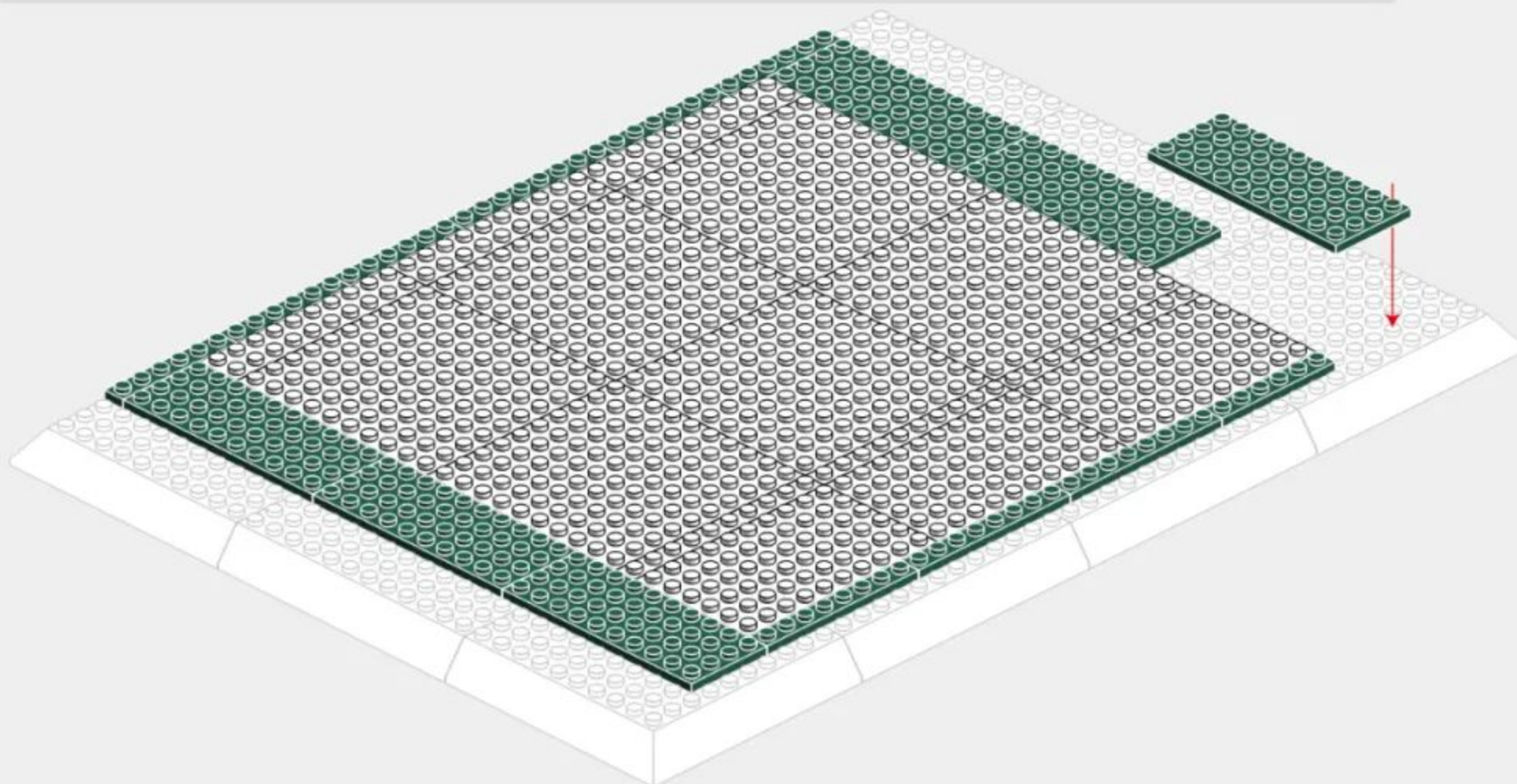
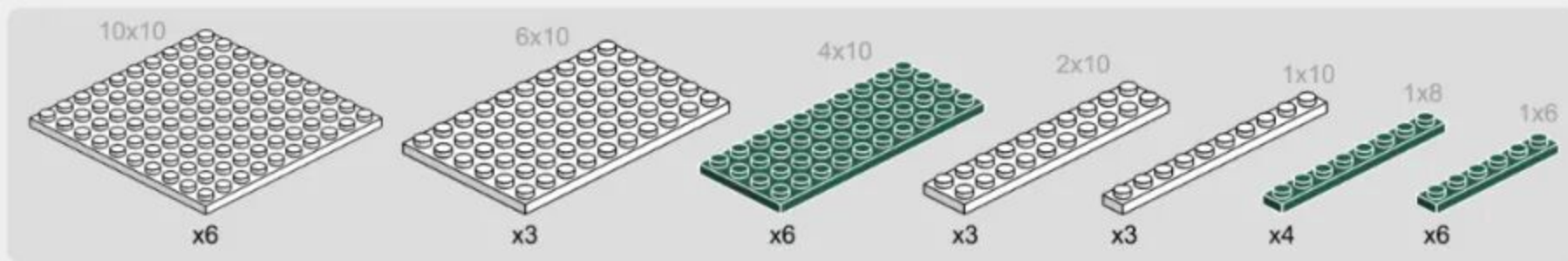

1-6

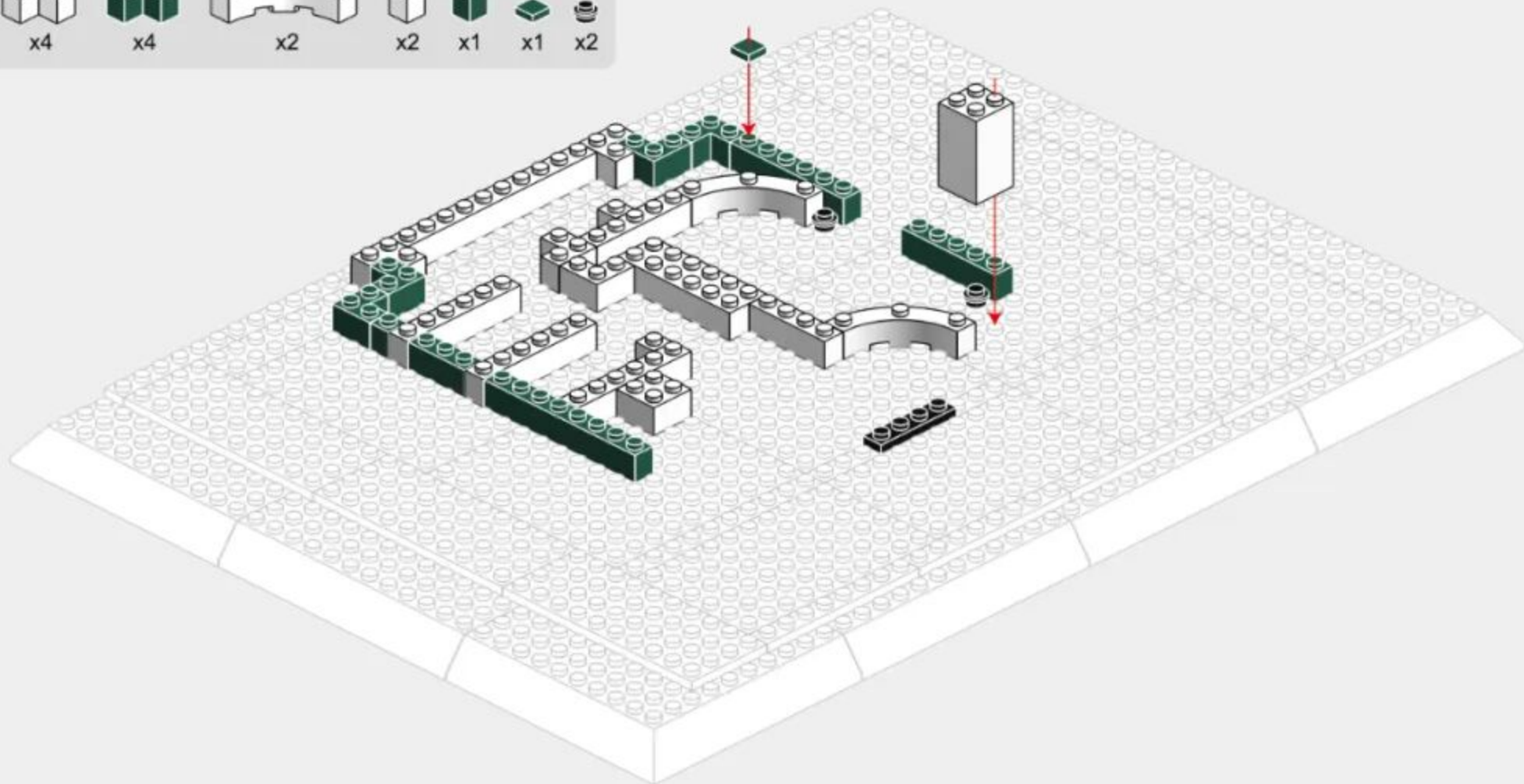
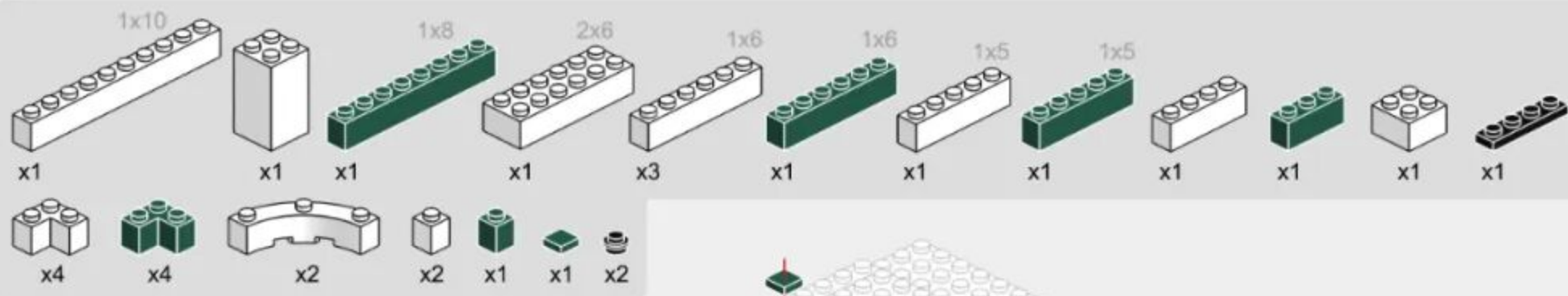

1-7

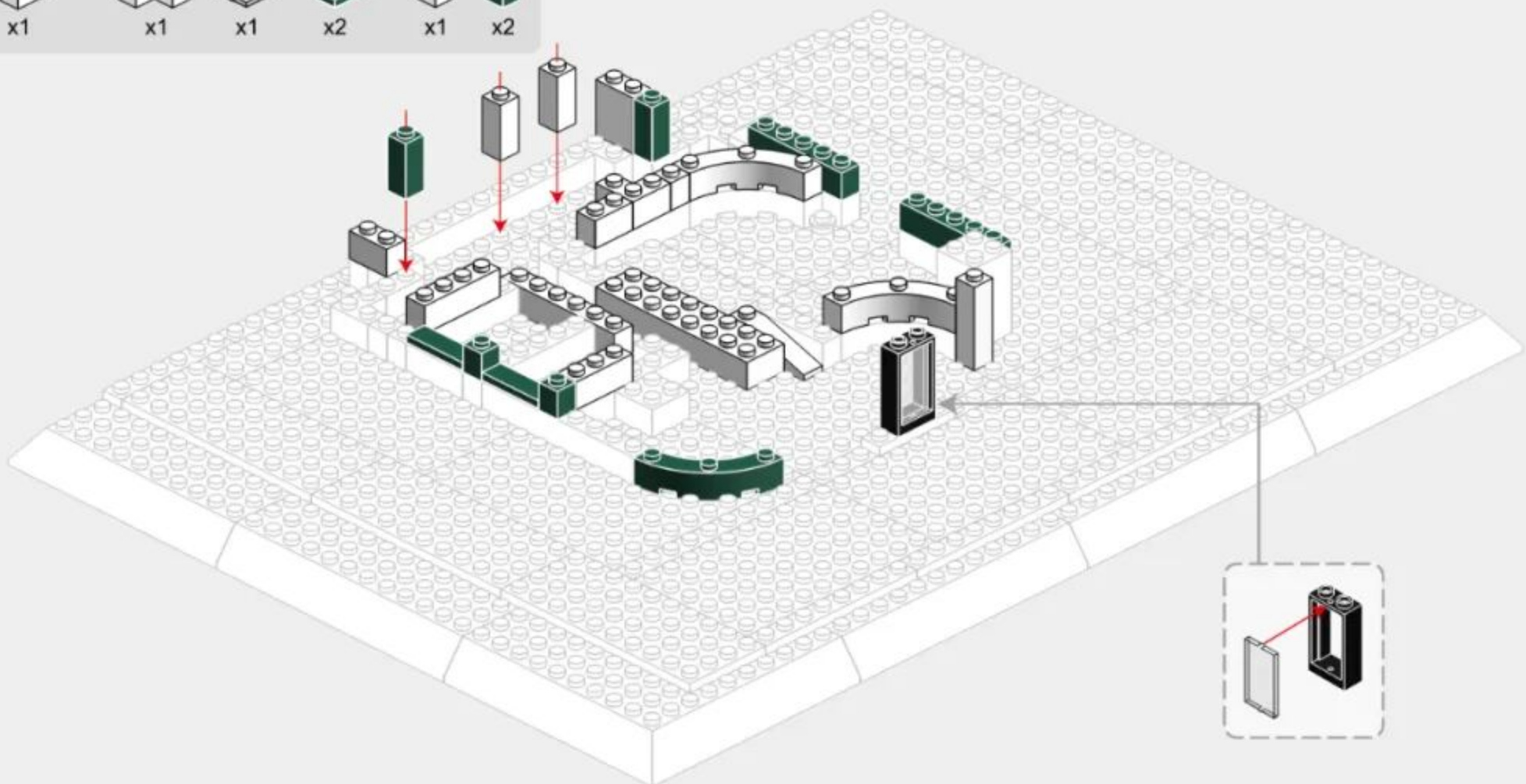

1-8

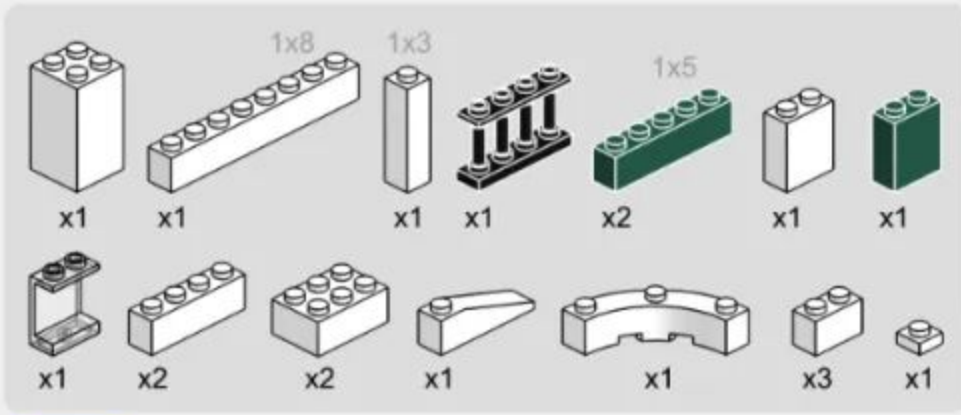

1-9

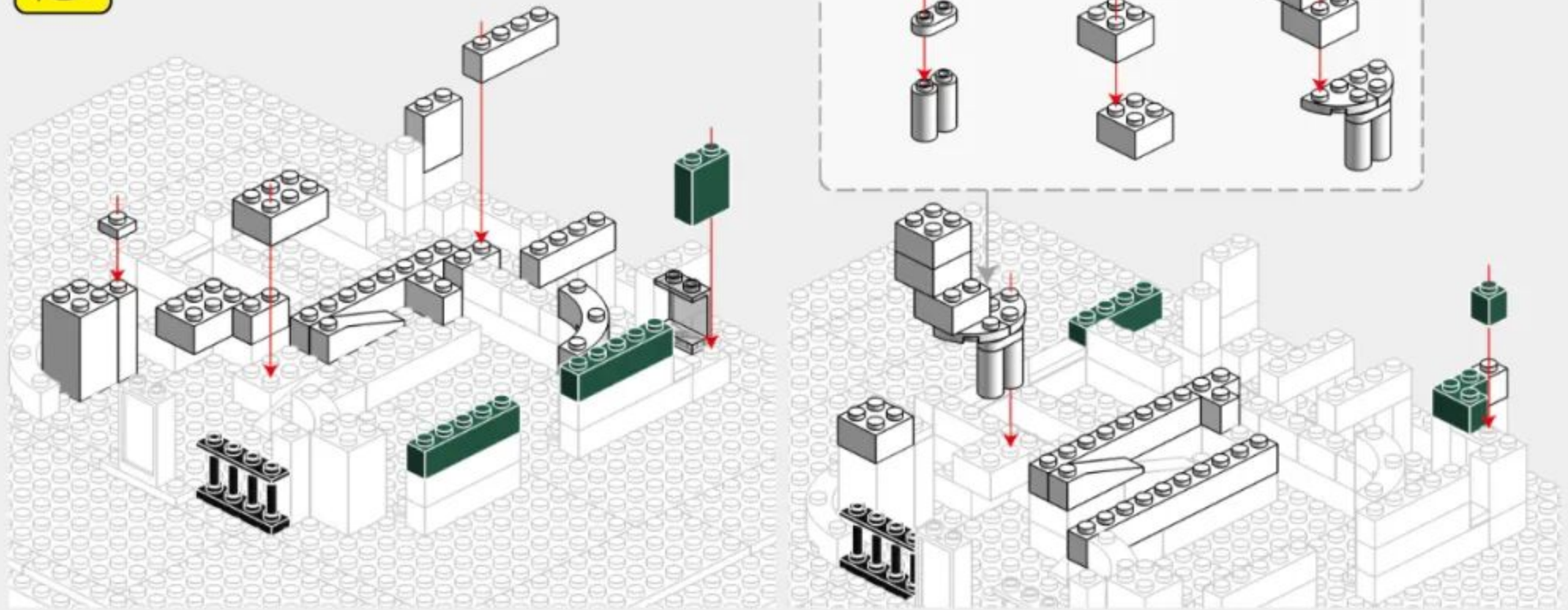
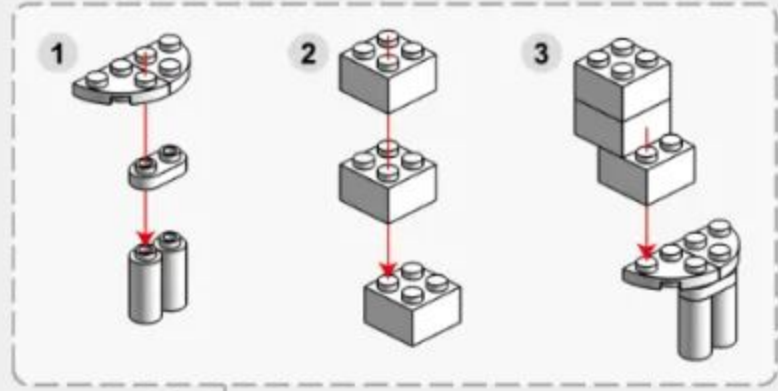
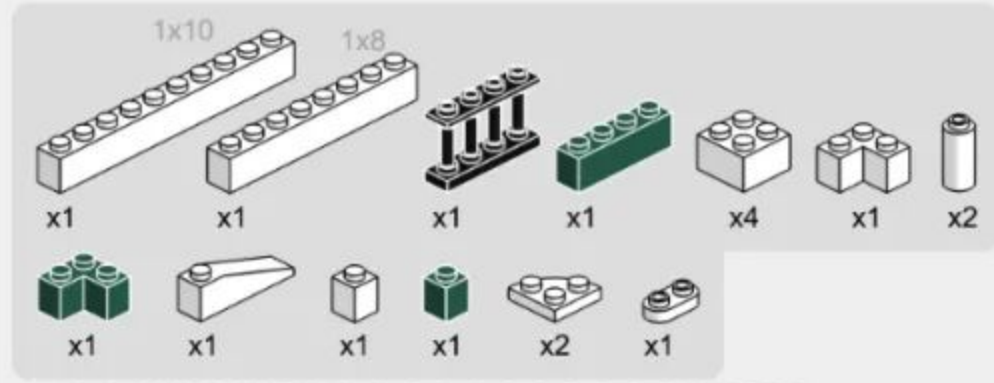

1-10

- 1x8
- x1
- x1
- x1
- x1
- x1
- x1
- x1
- x3
- x4
- x1
- x1
- x1
- x1
- x2

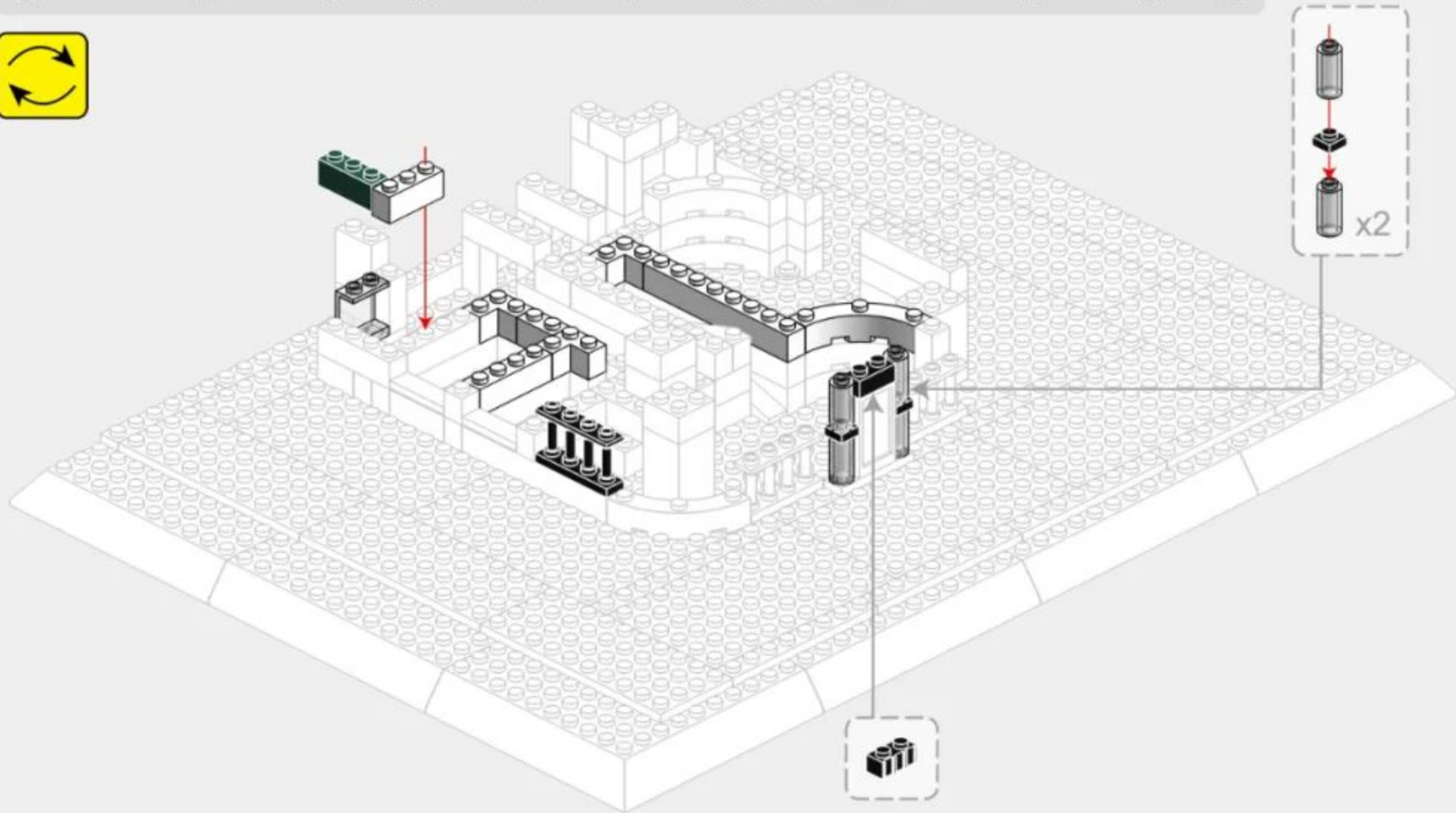

1-11

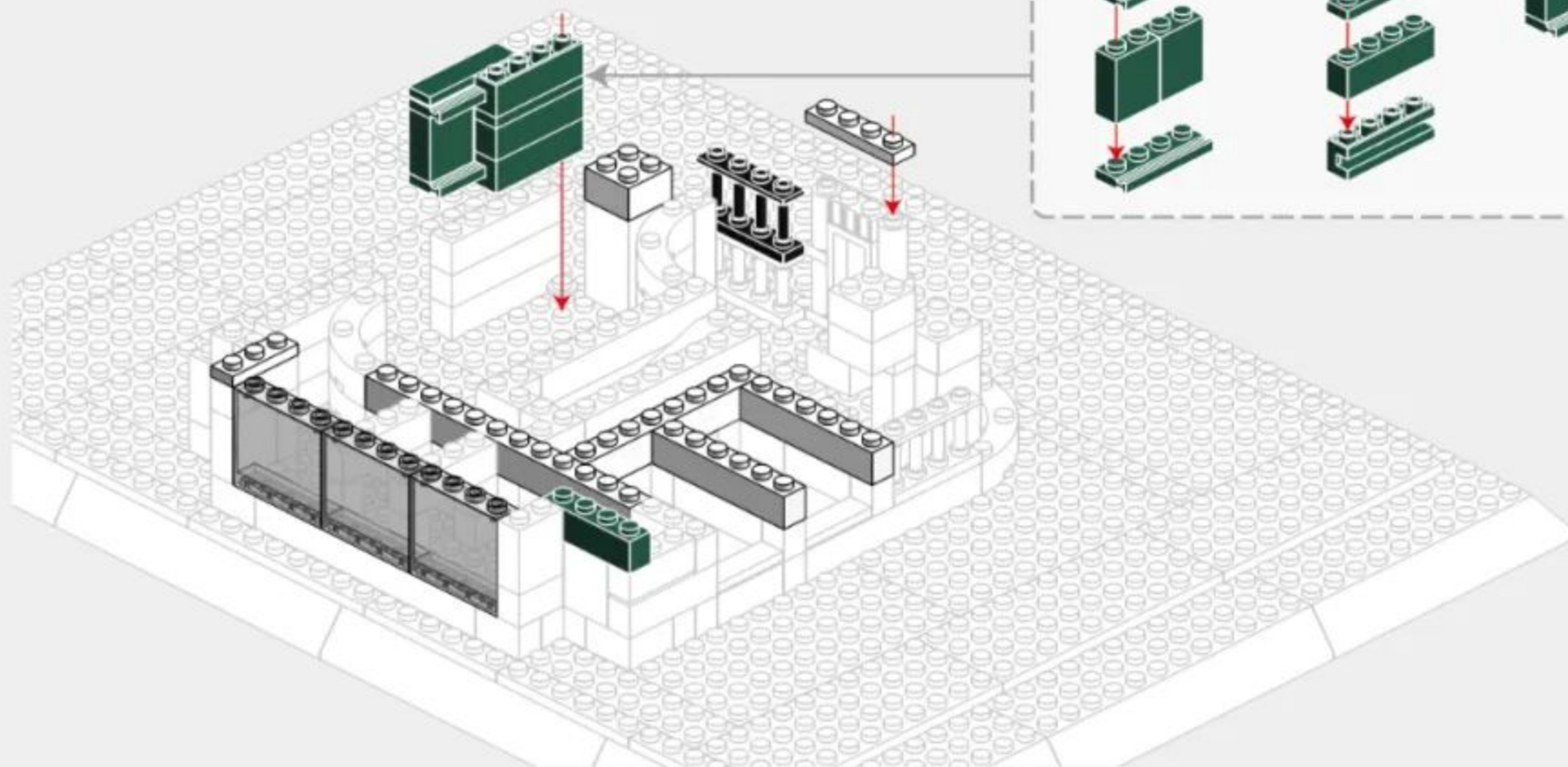
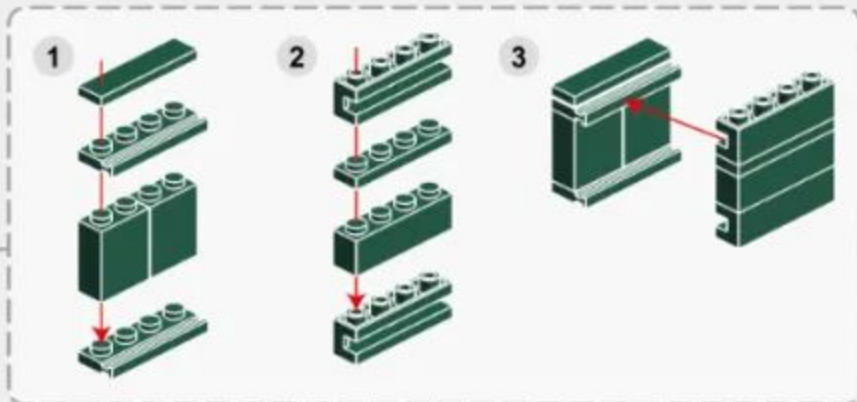
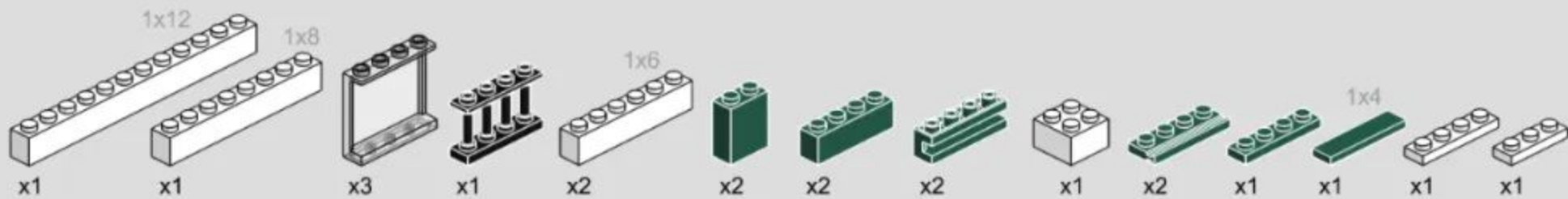

1-12

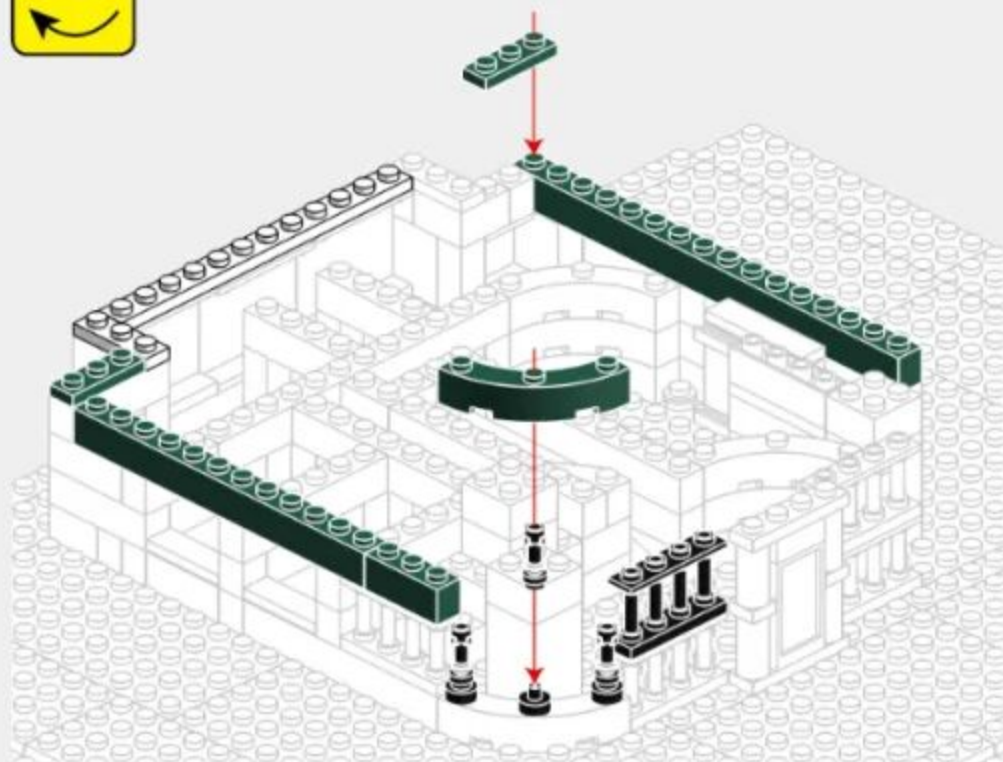
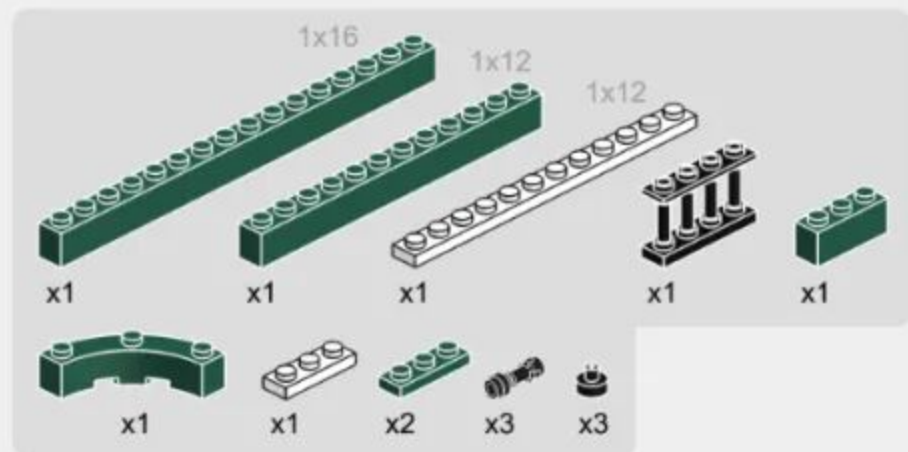

1-13

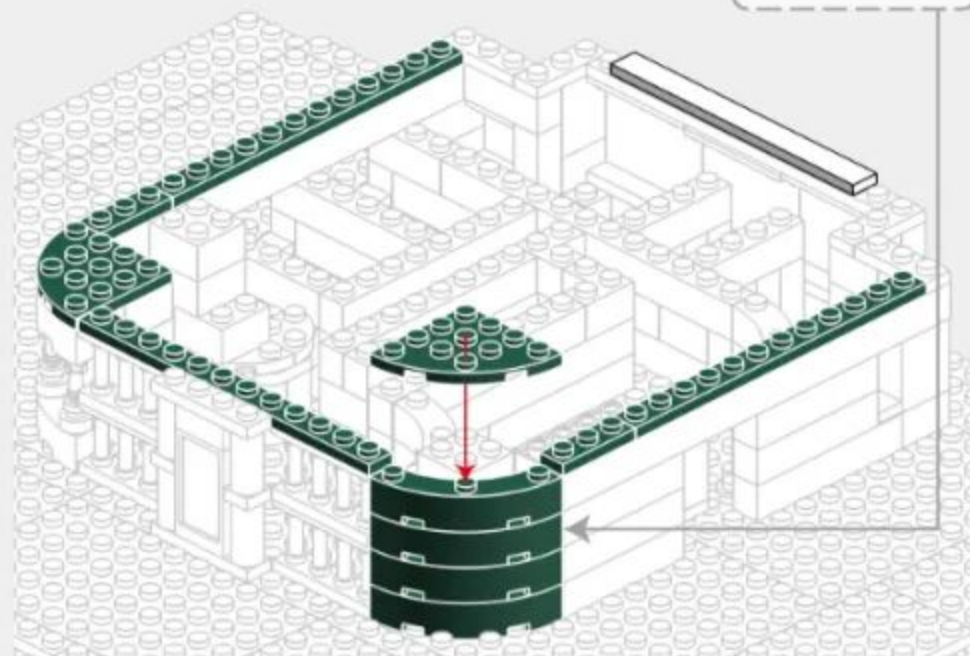
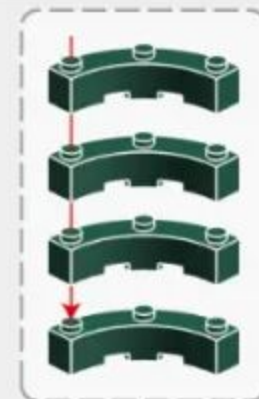
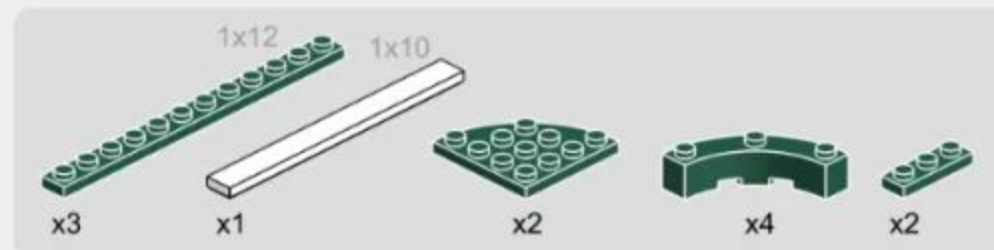



174PCS

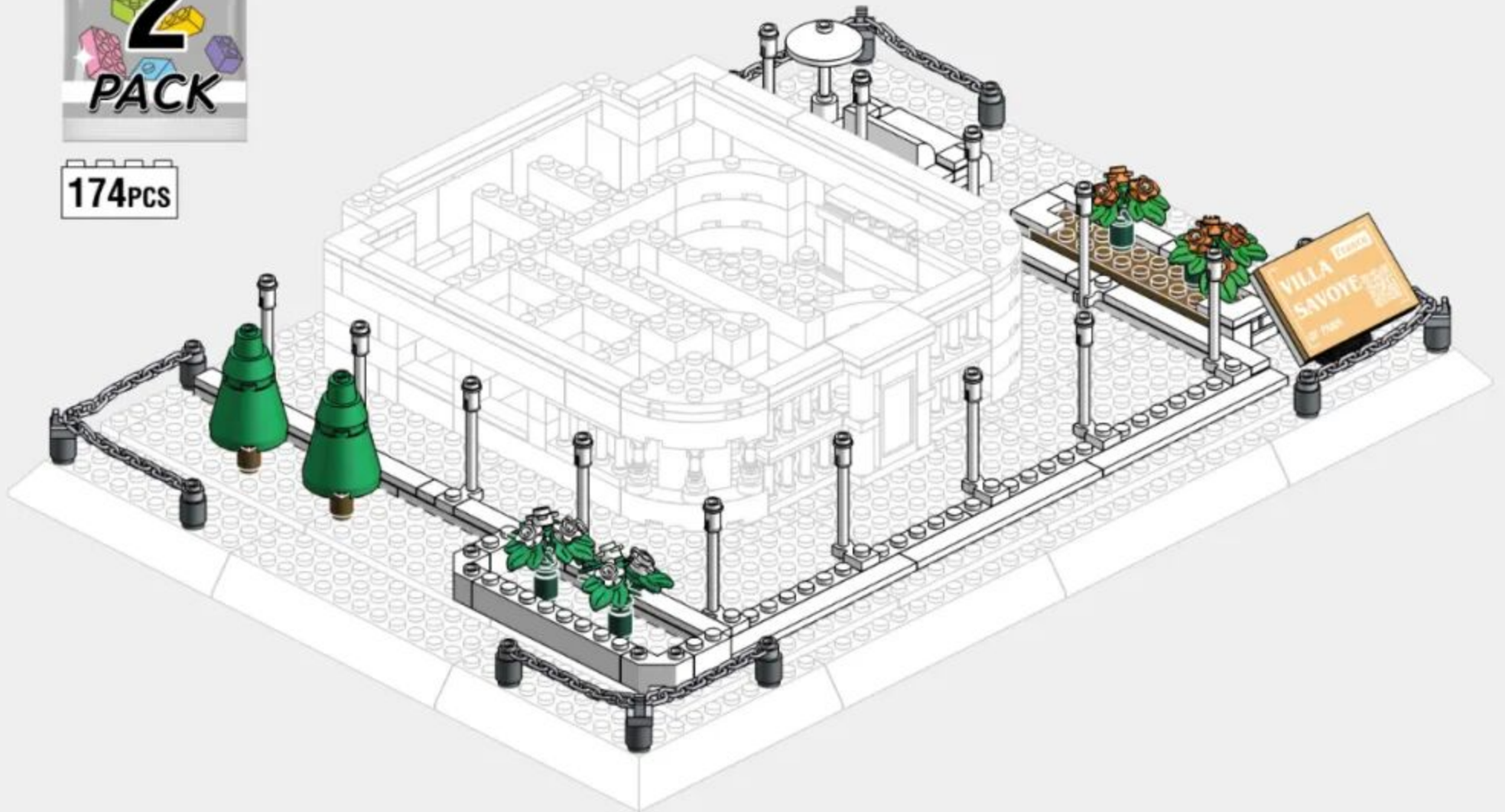

2-1

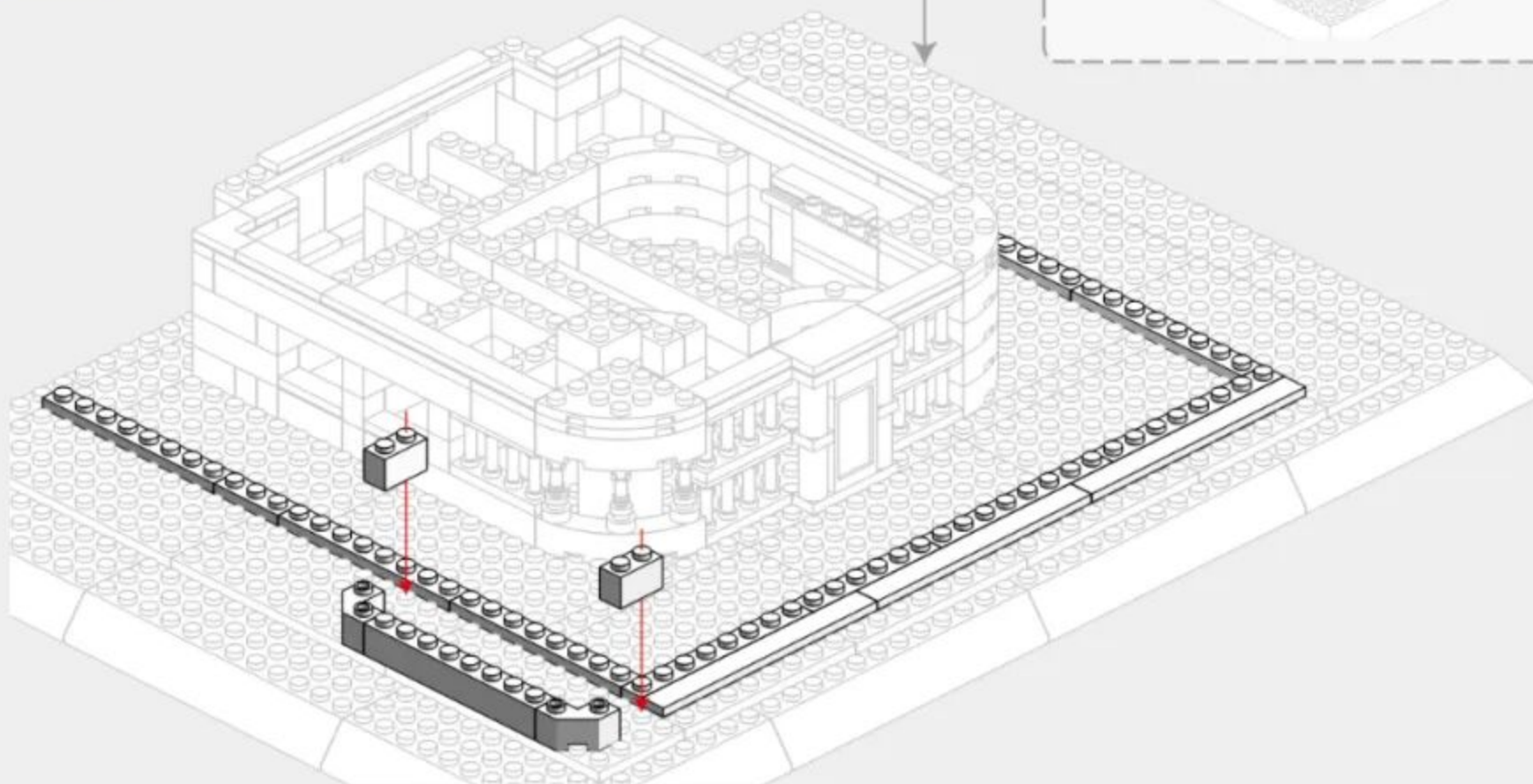
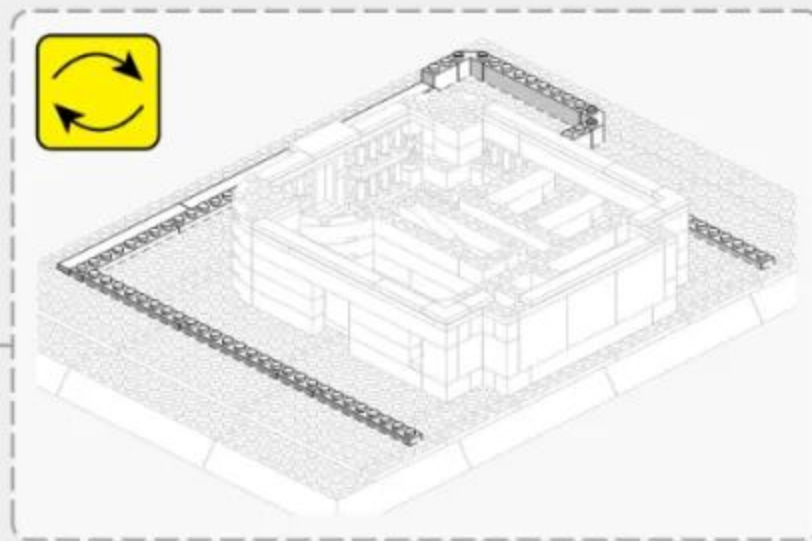
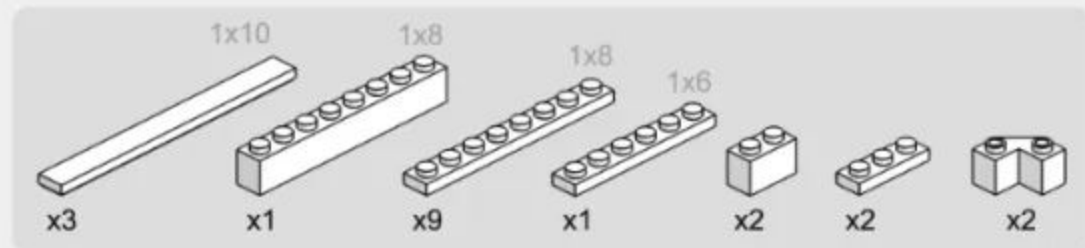

2-2

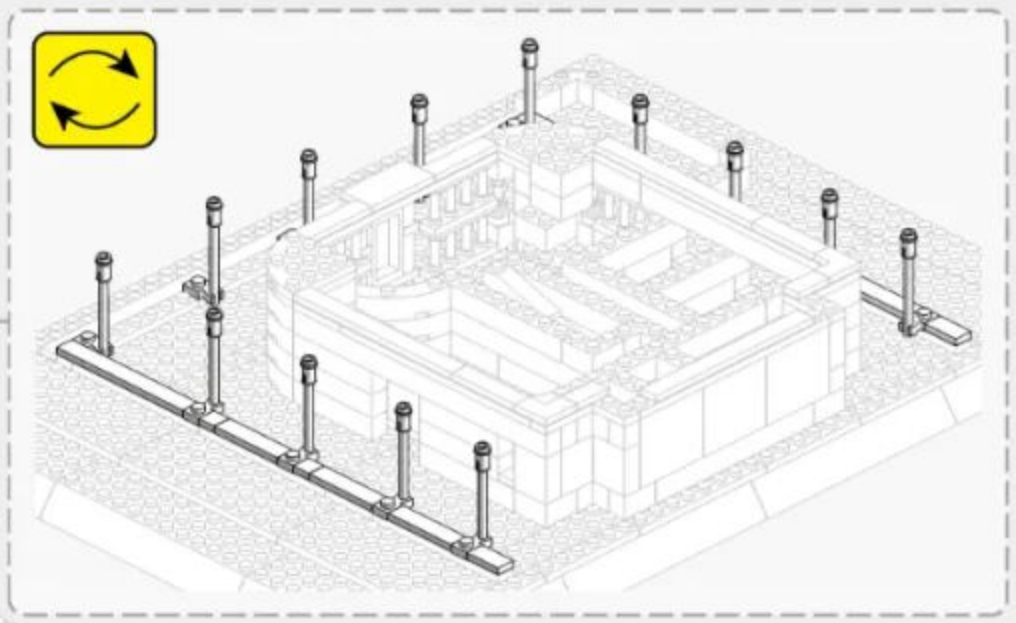
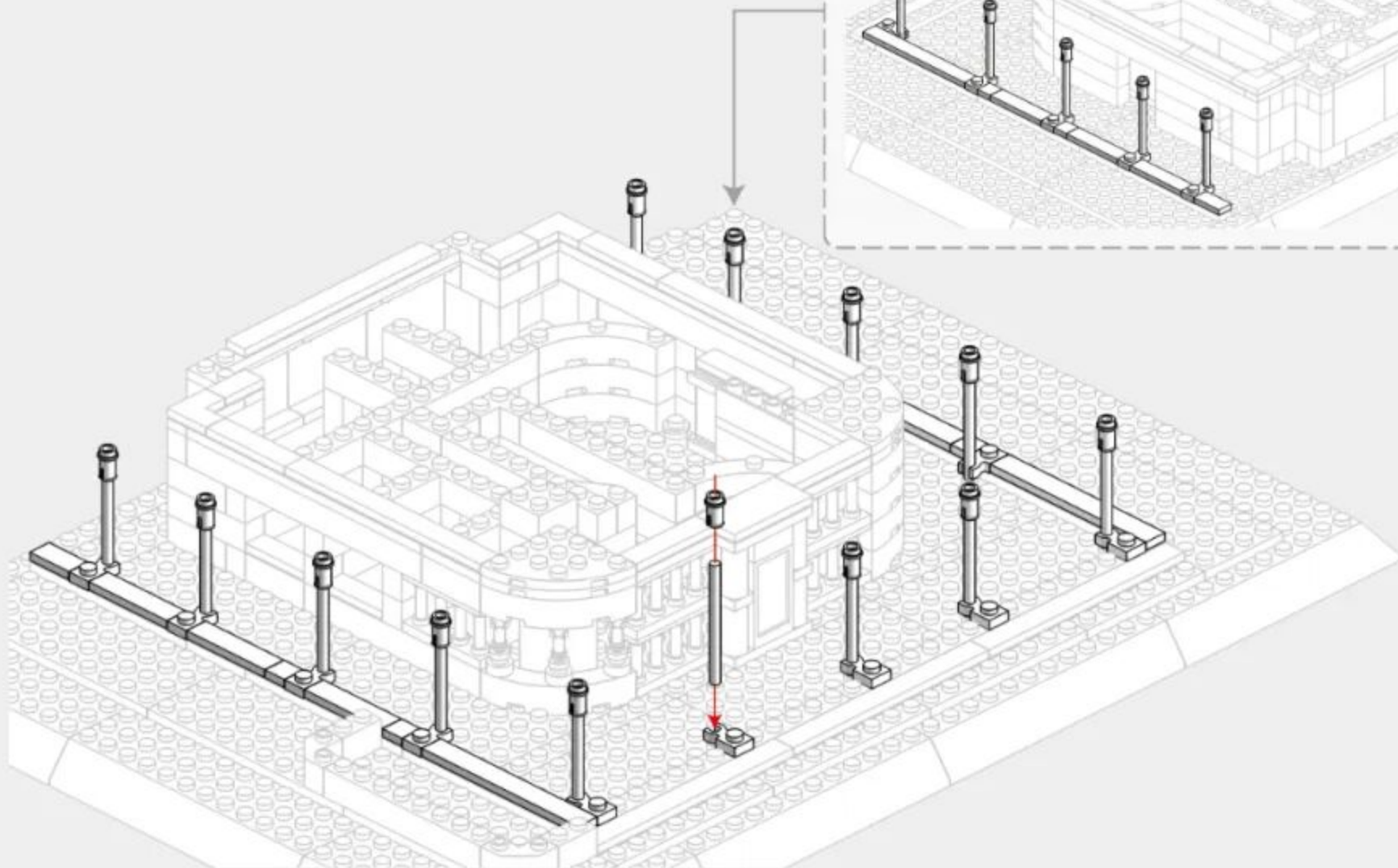
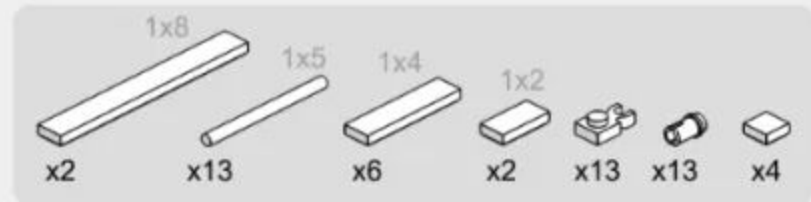

2-3

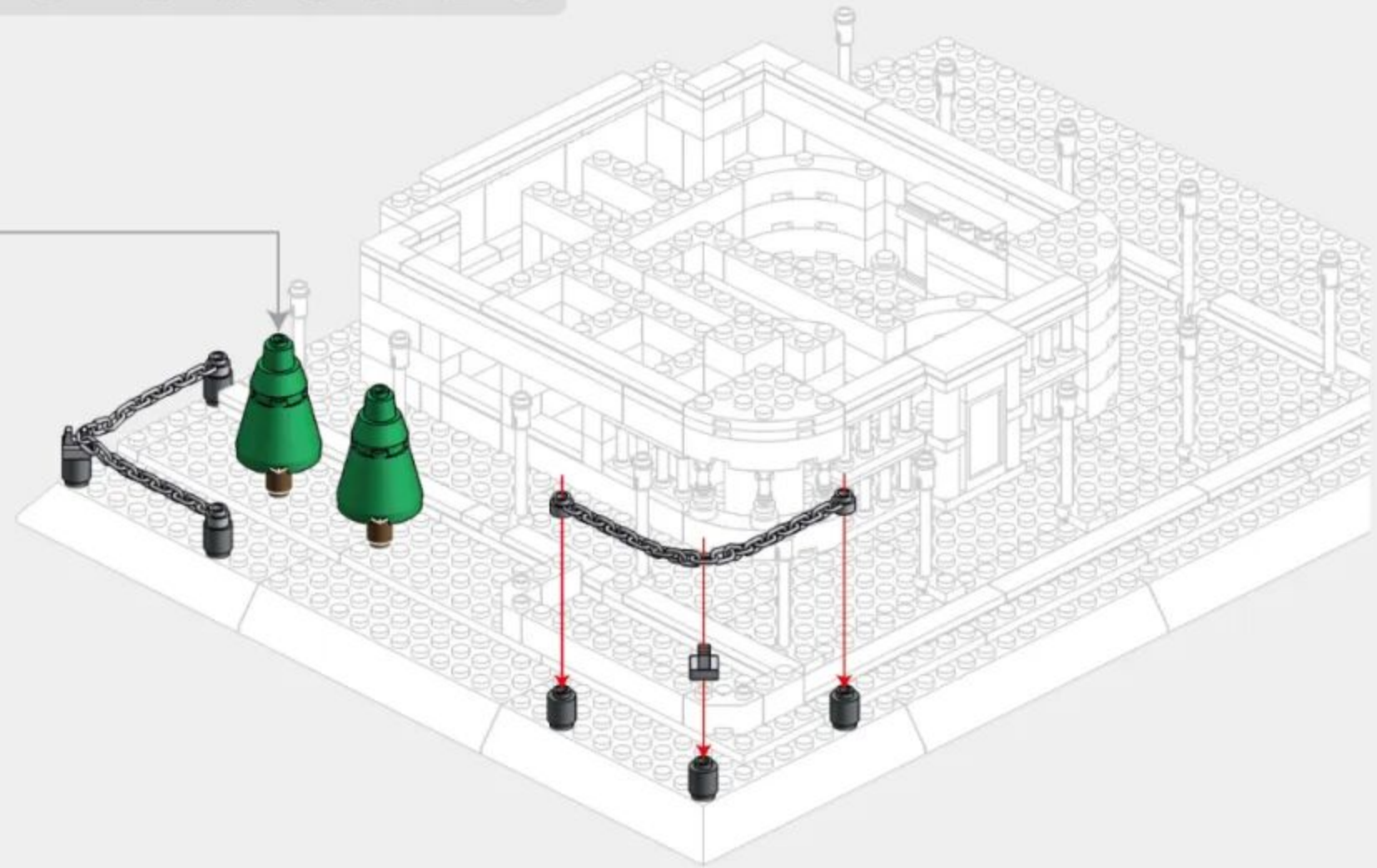
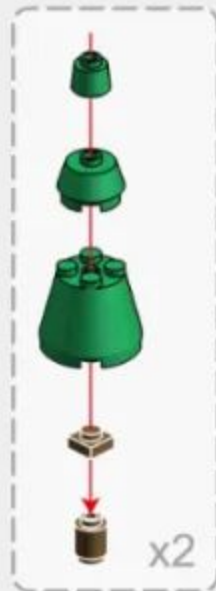
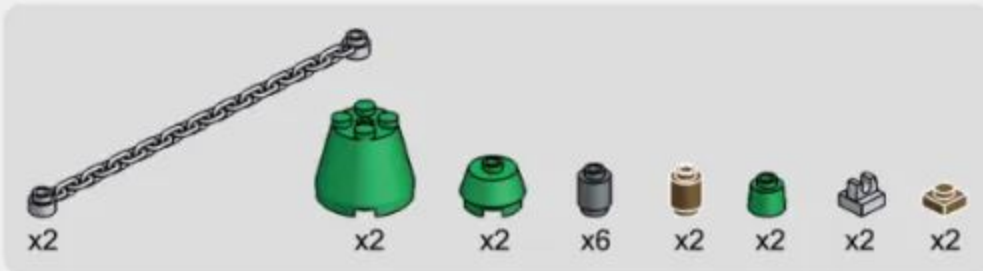

2-4

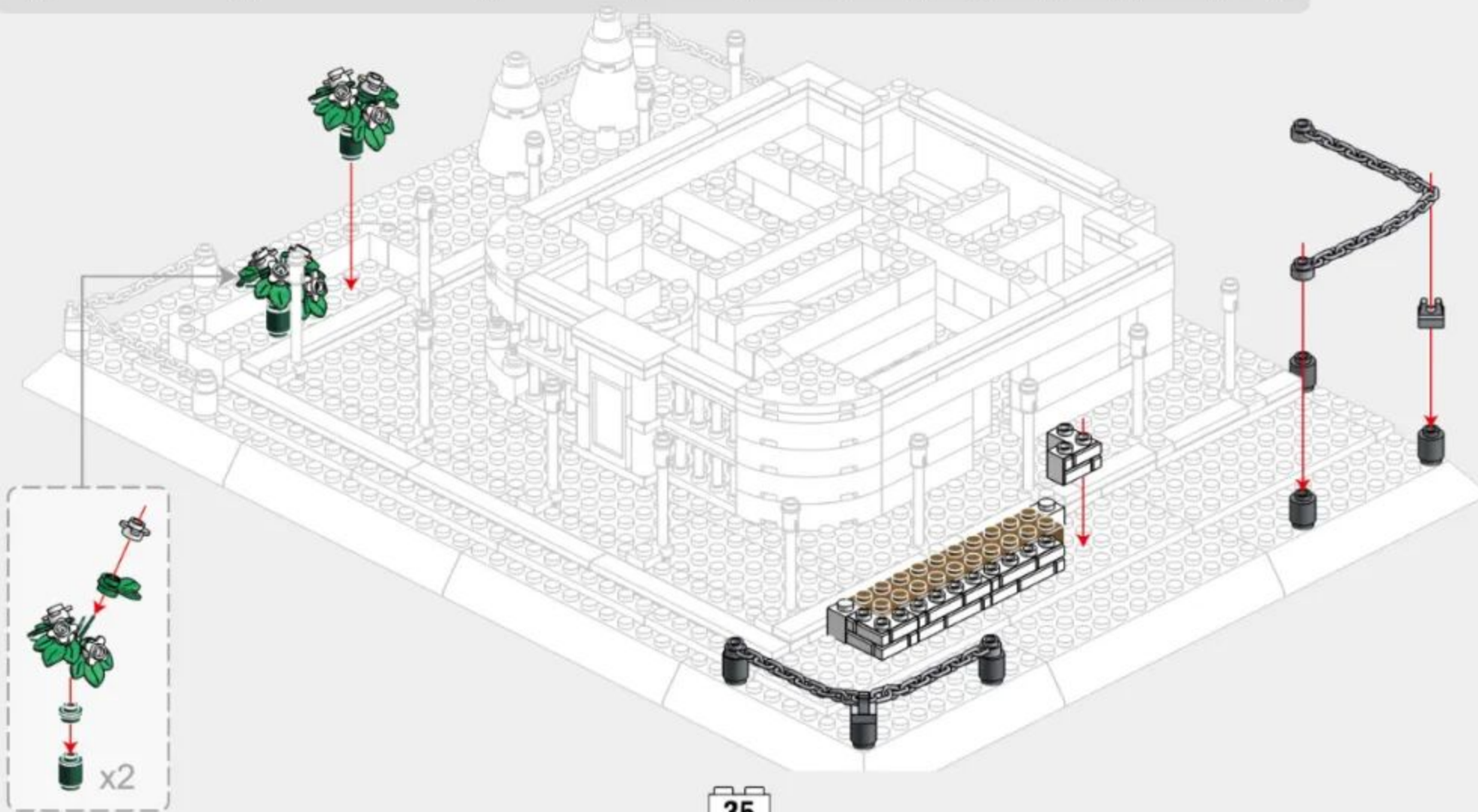

2-5

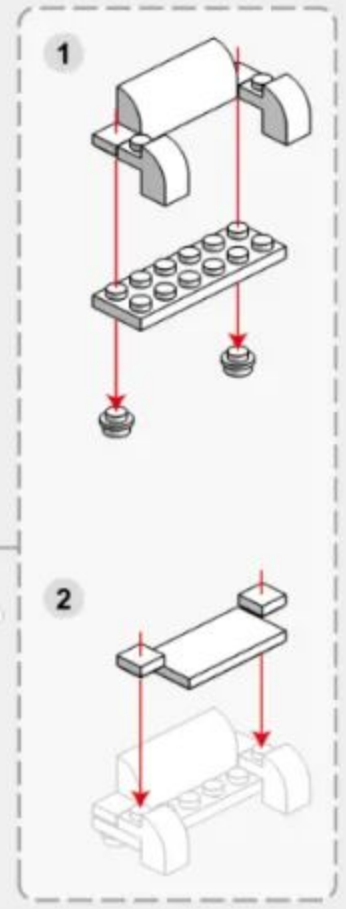
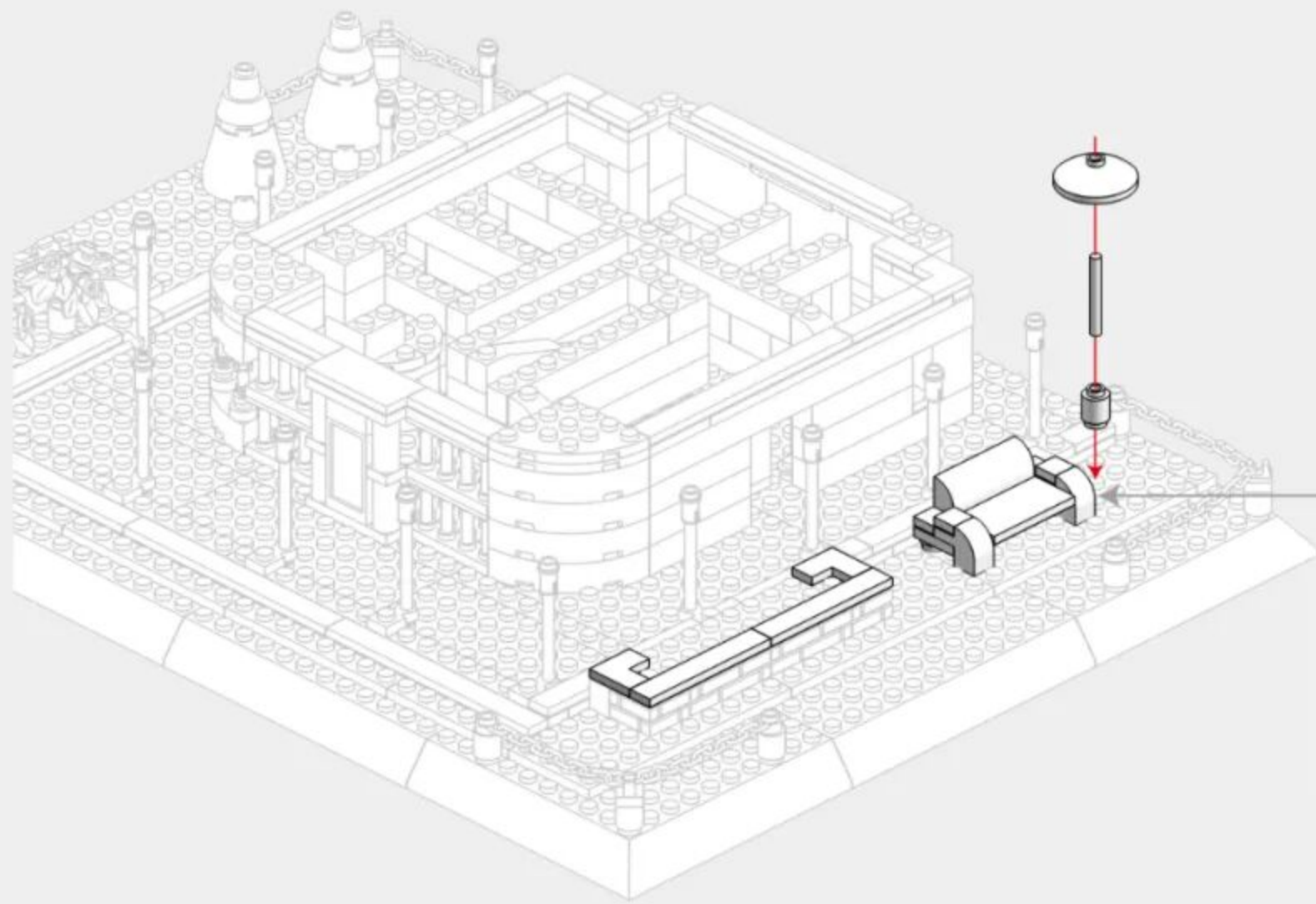
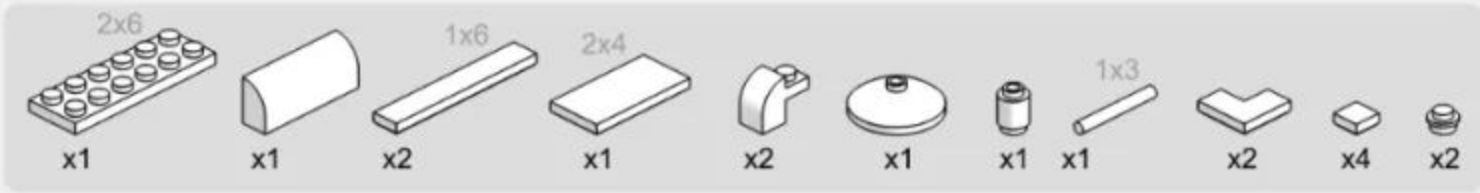

2-6

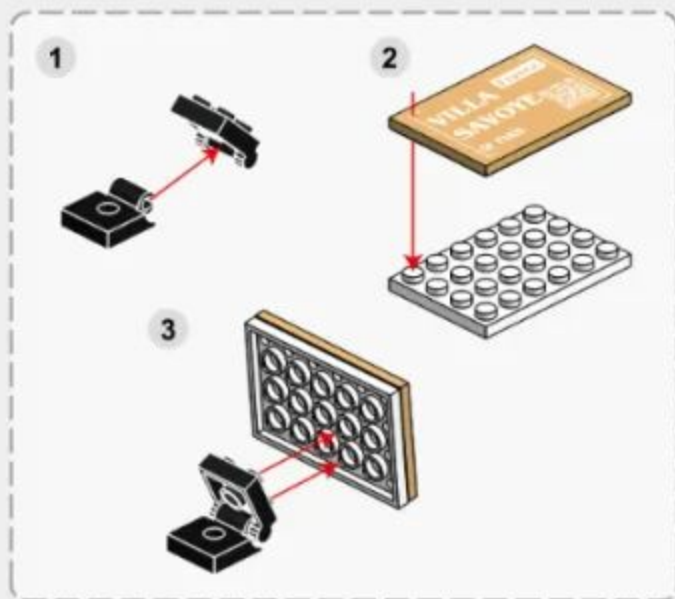
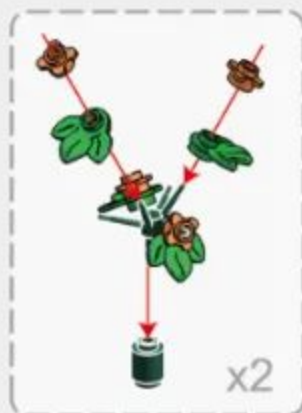



286PCS

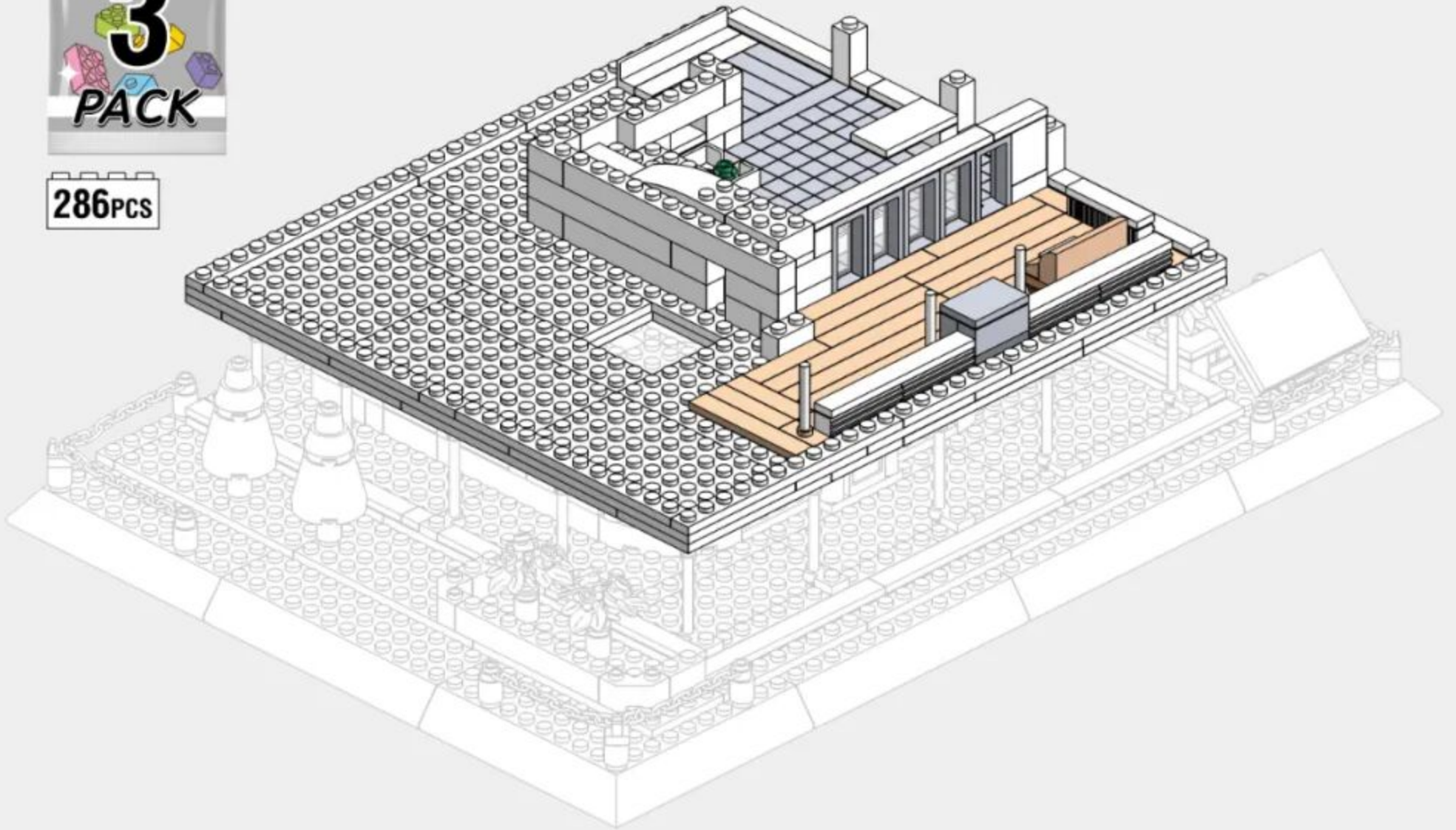

3-1

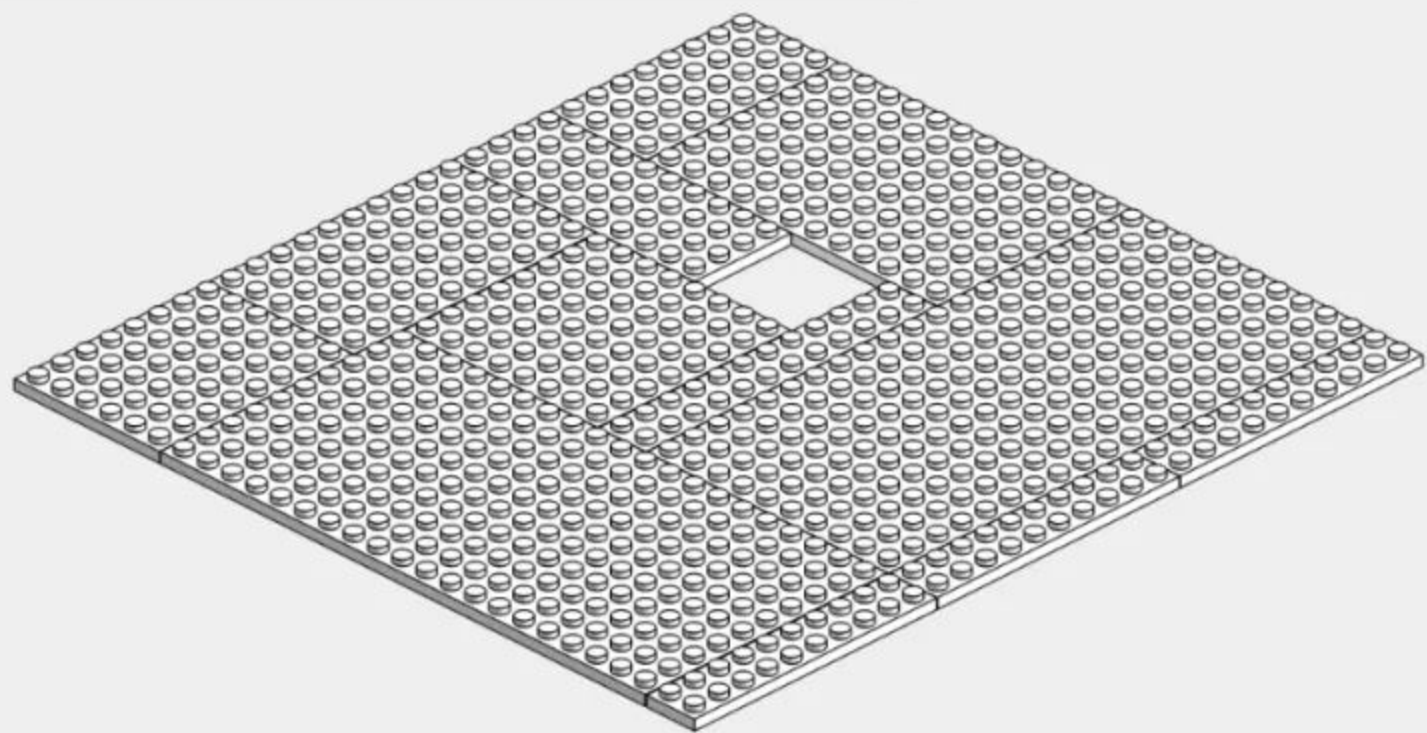
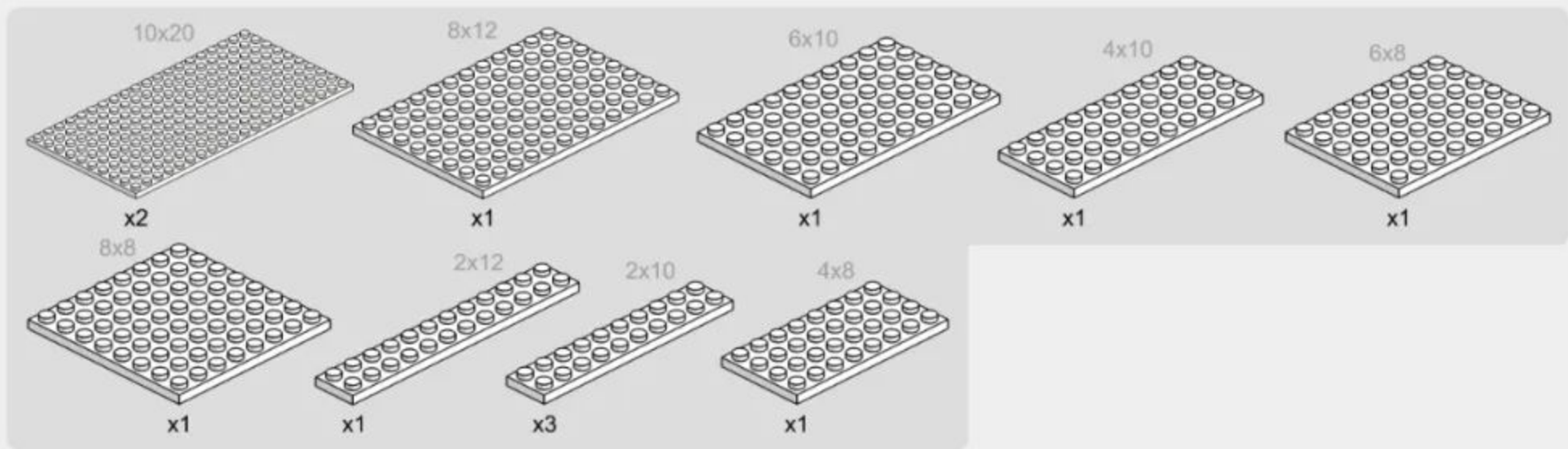

3-2

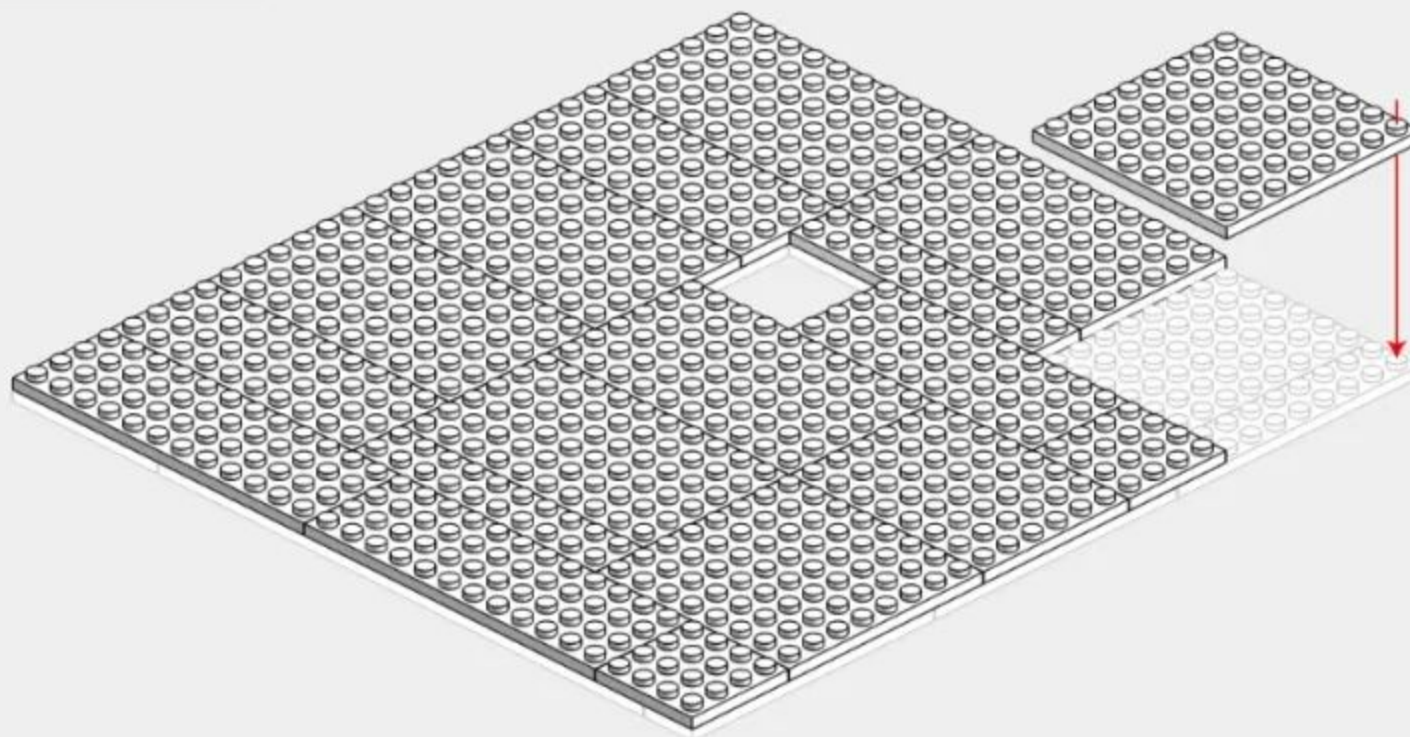
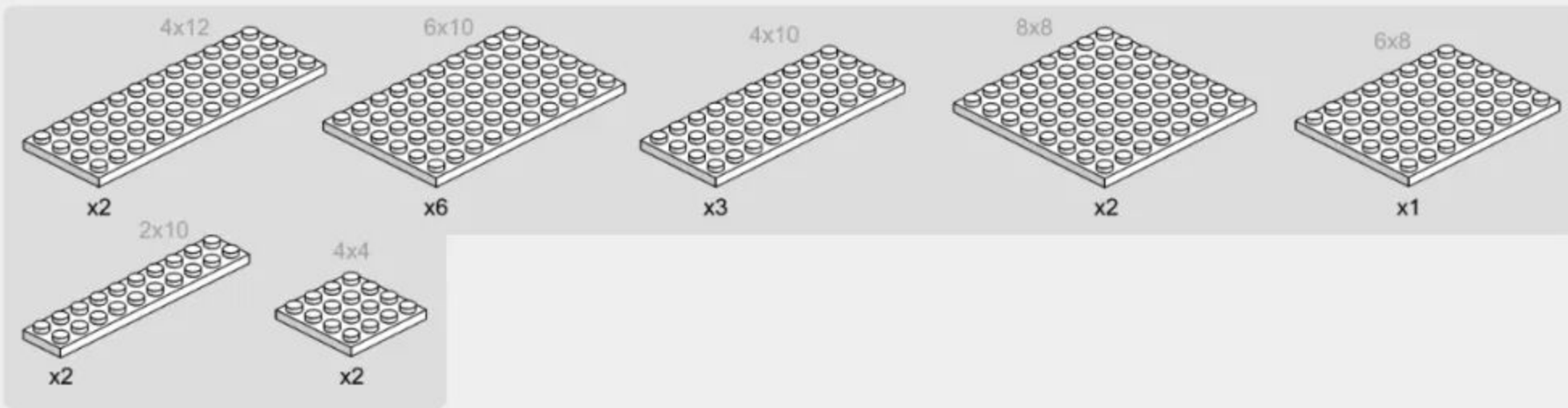

3-3

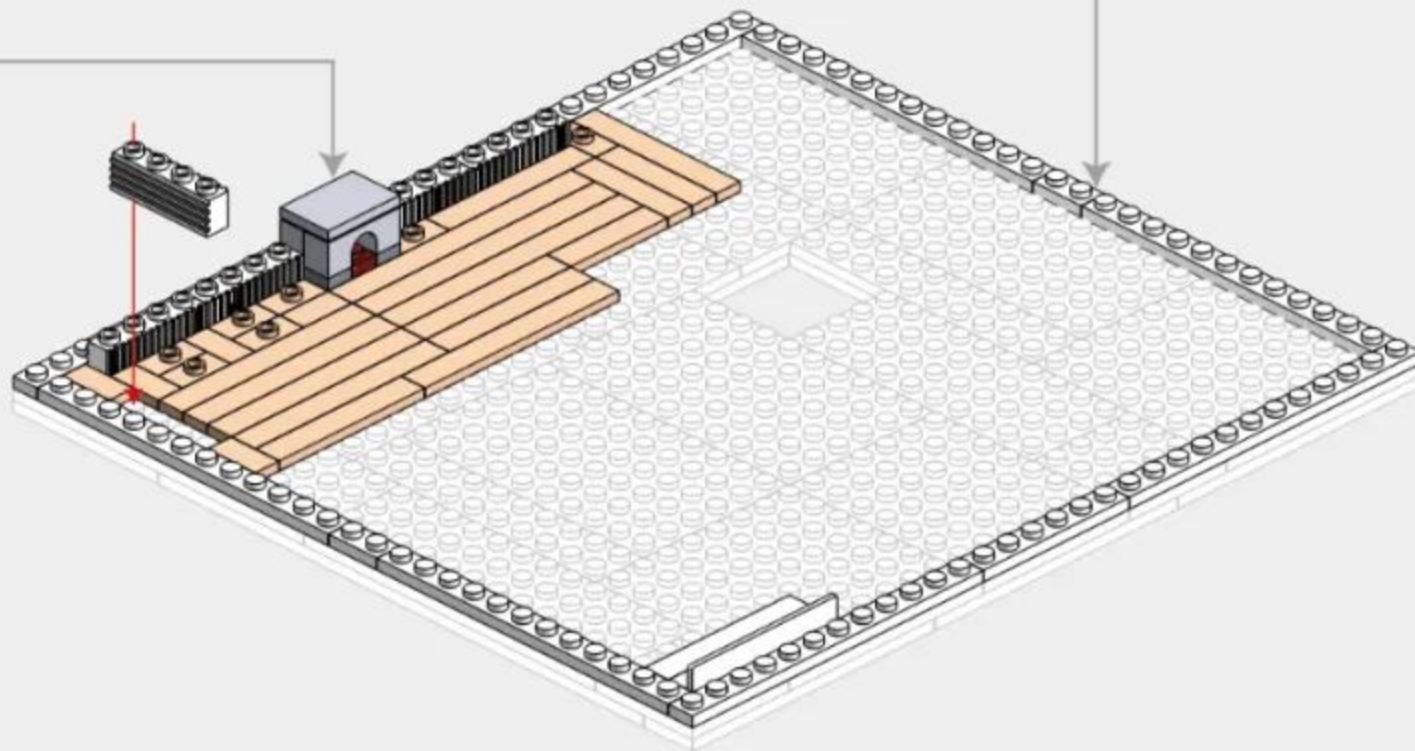
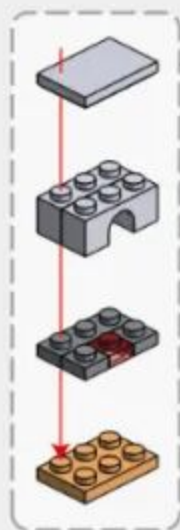
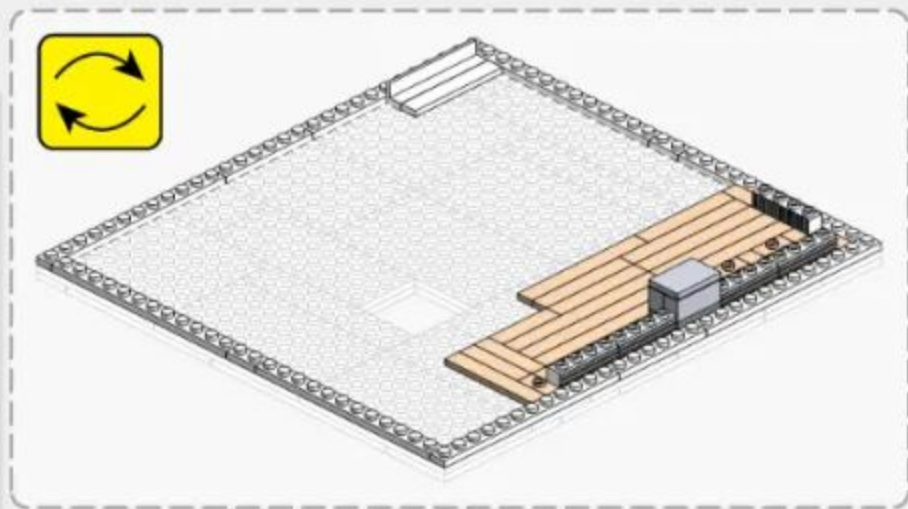
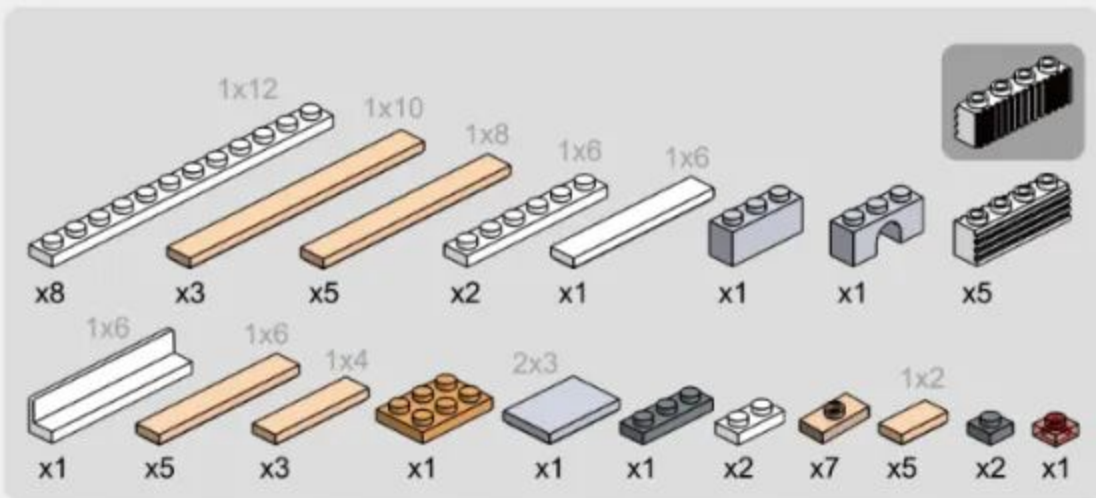



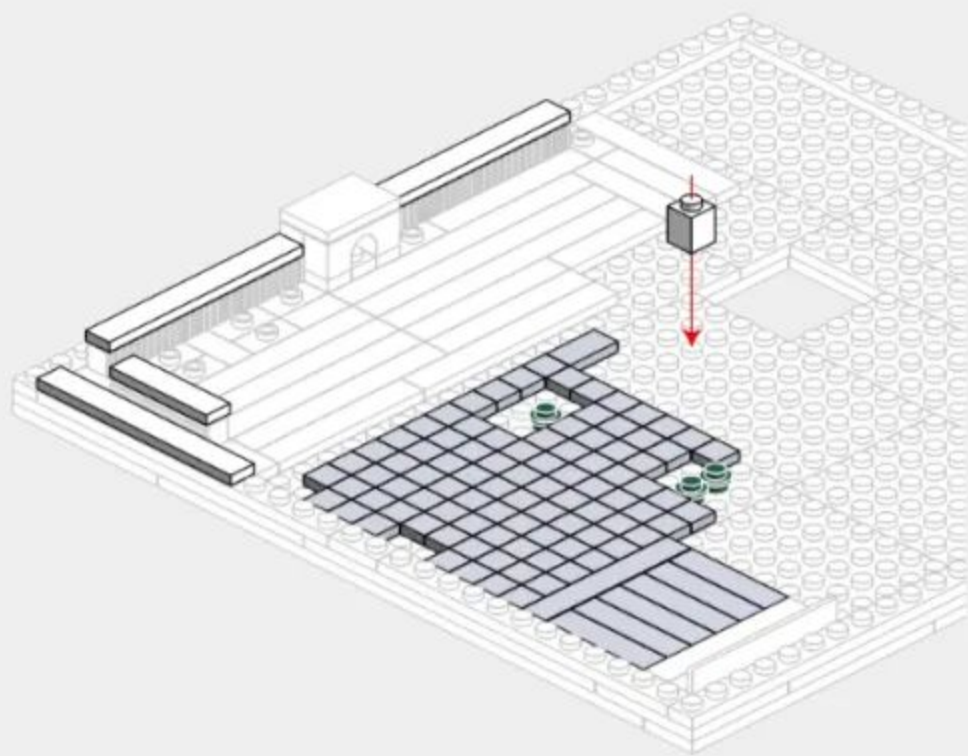
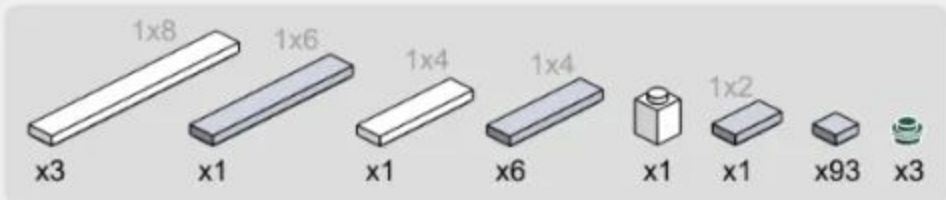

3-4

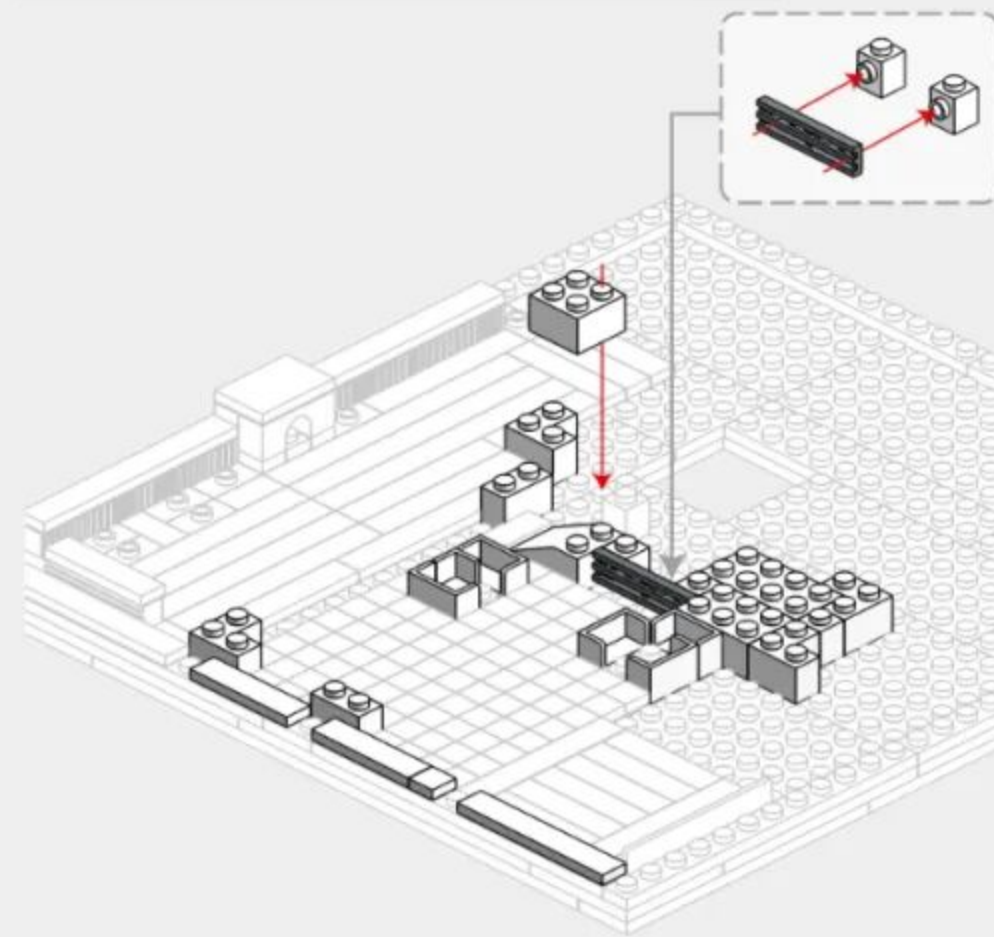
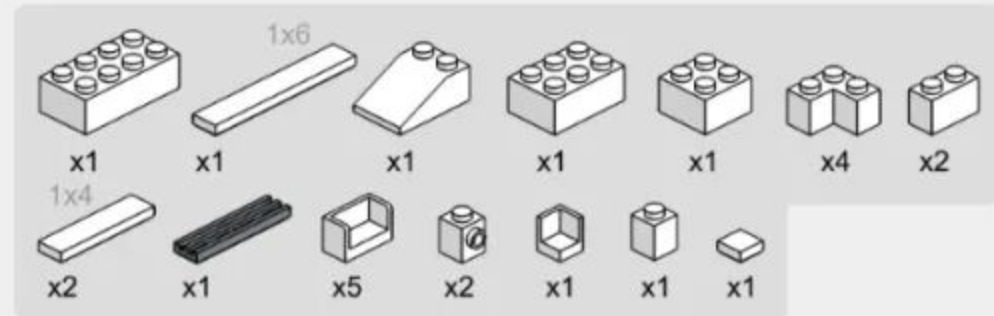

3-5



3-6

-  x5
 -  x1
 -  x1
 -  x1
 -  x2
 -  x3
 -  x3
 -  x2
 -  x2
 -  x2
 -  x4
 -  x1
 -  x3
 -  x1
-  x2
 -  x4
 -  x1
 -  x4
 -  x3

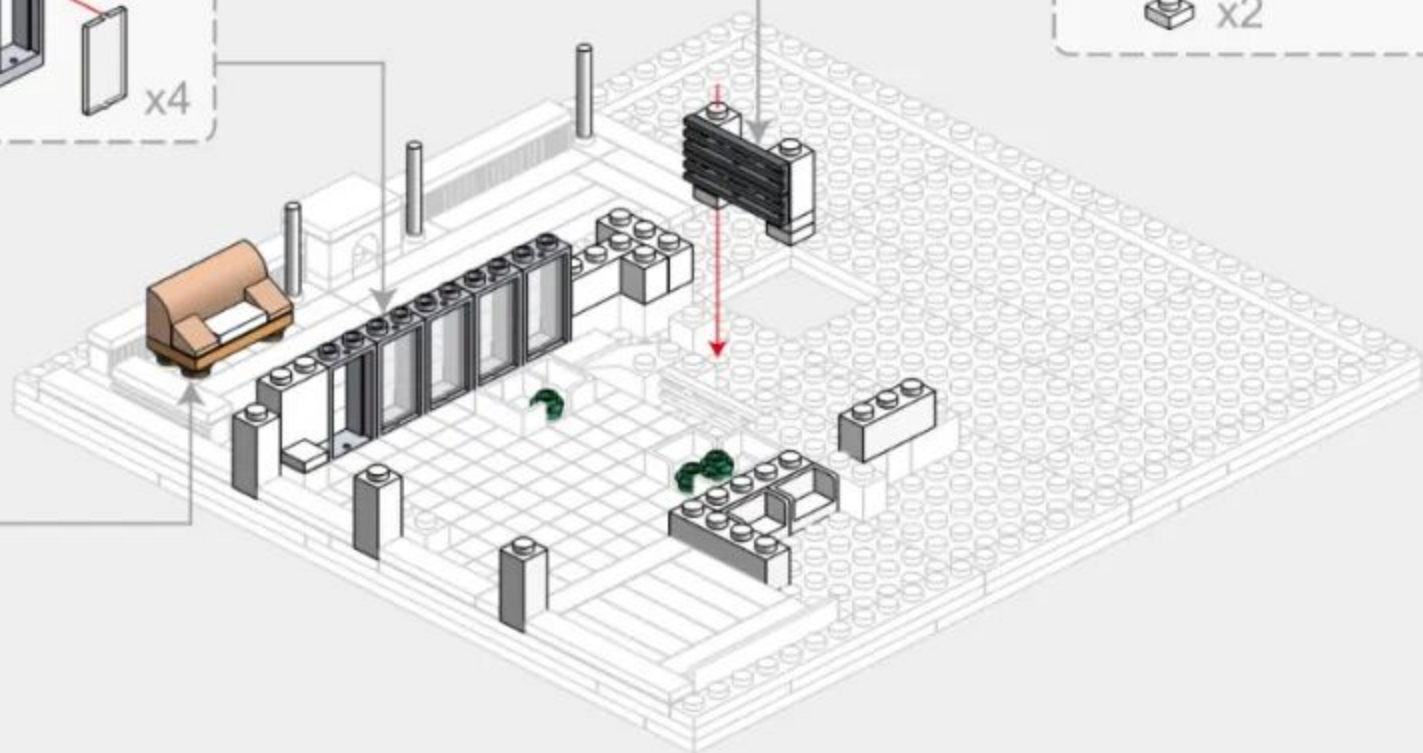
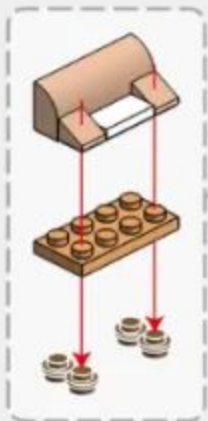
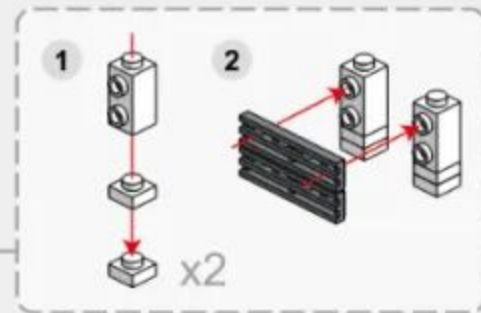
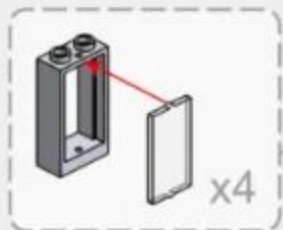

3-7

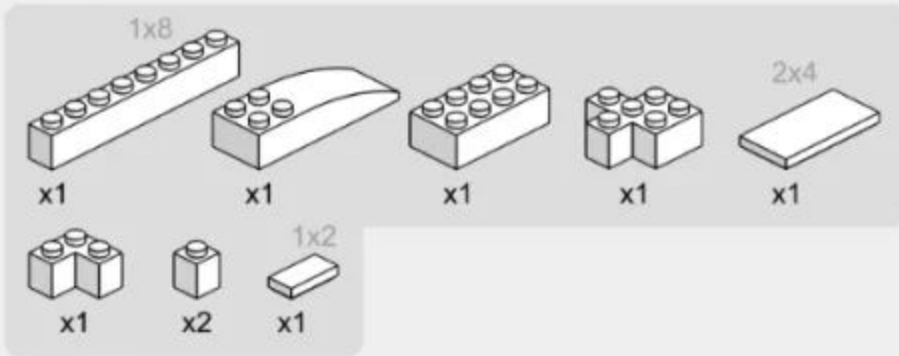

3-8

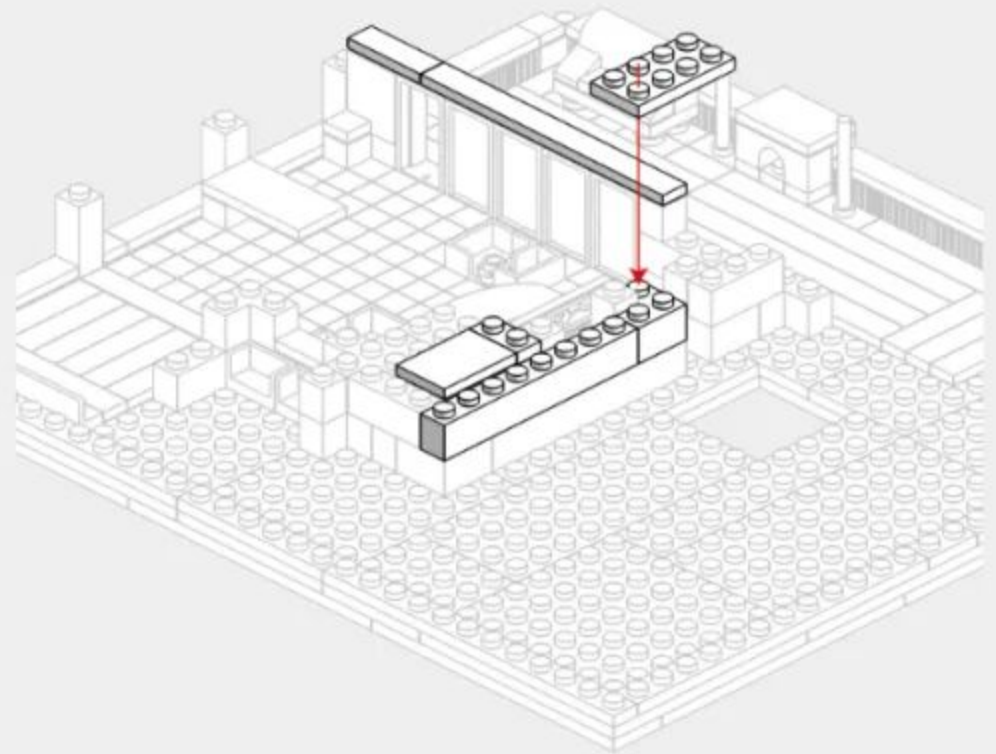
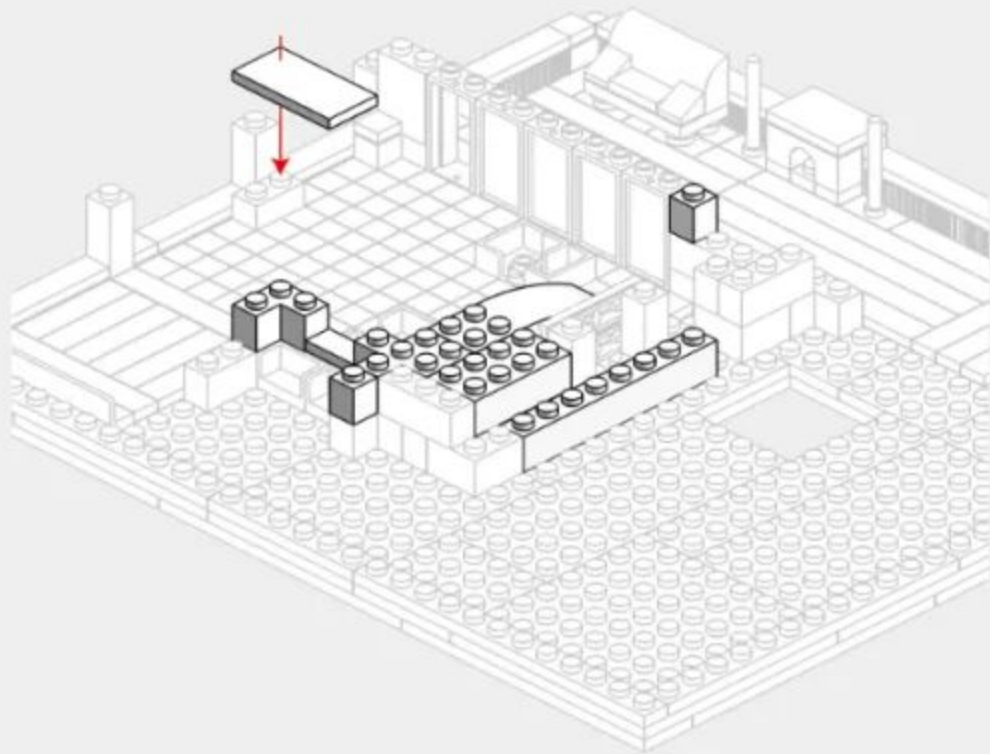
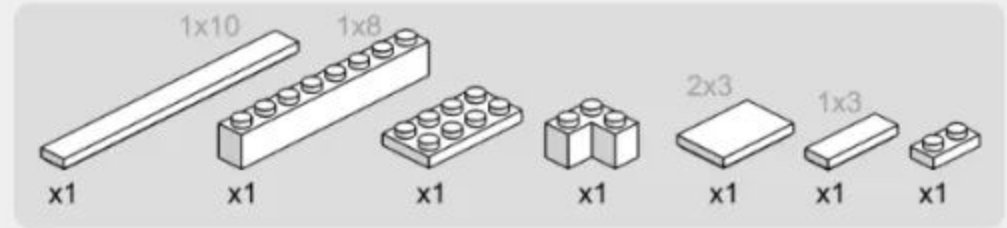

3-9

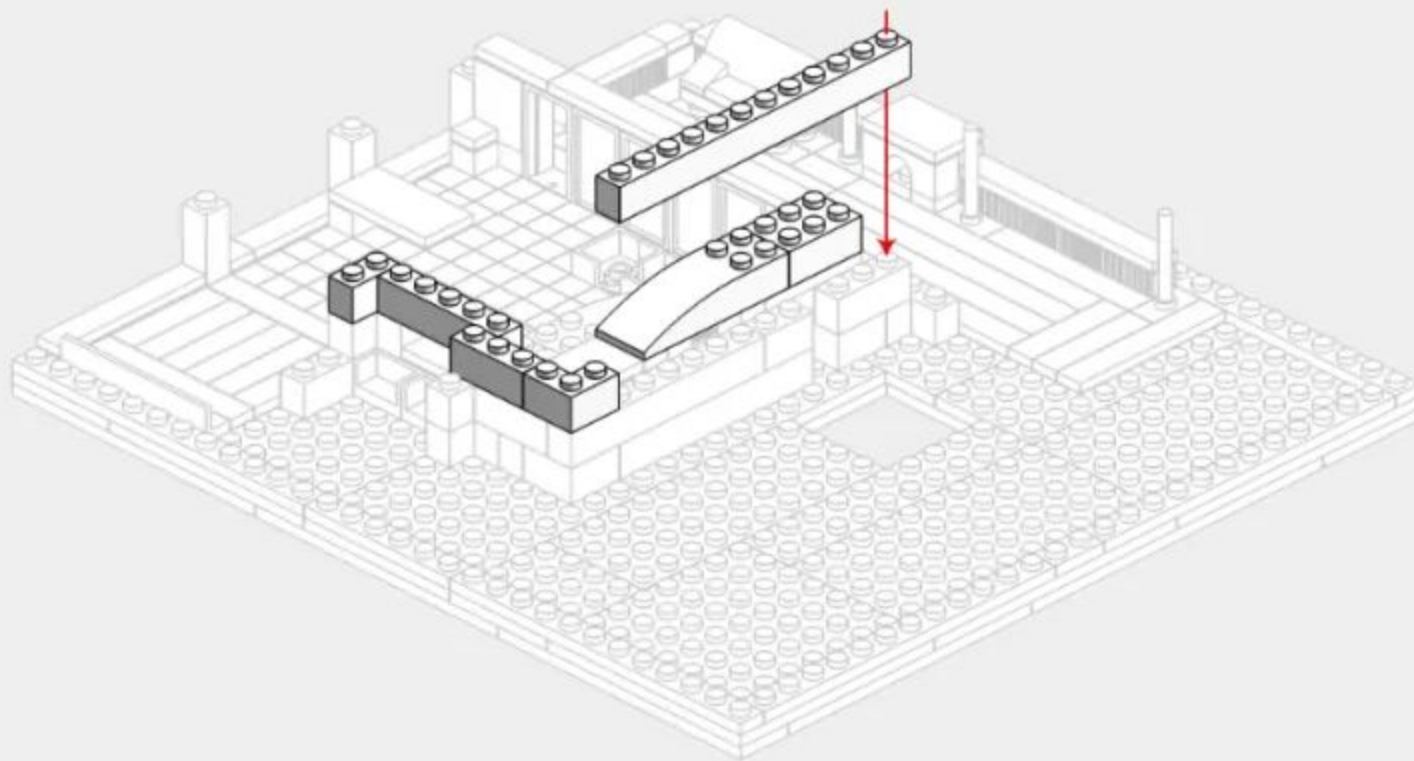
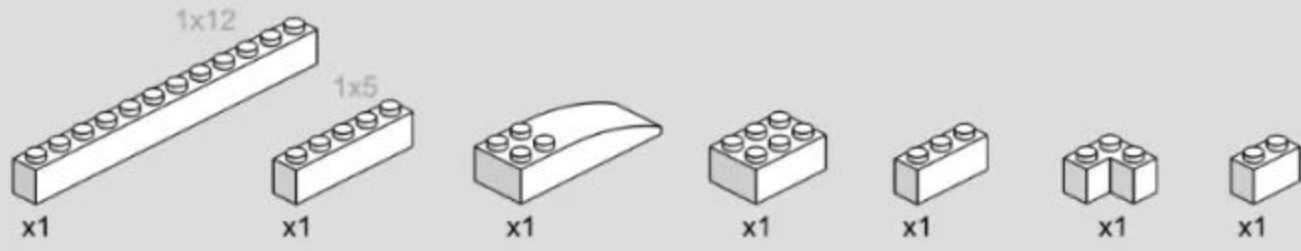



276PCS

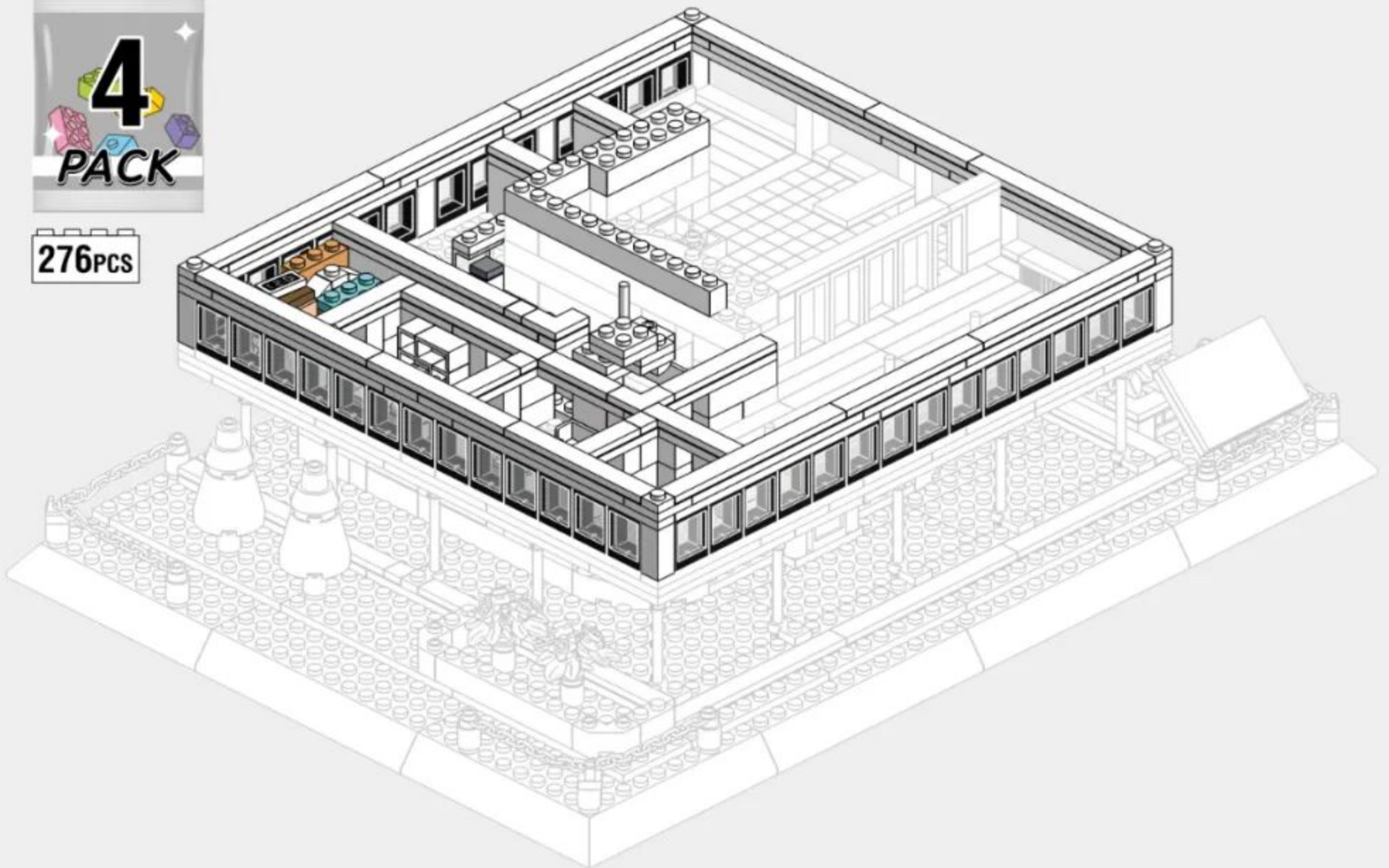

46

4-1

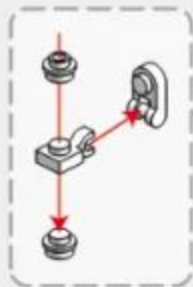
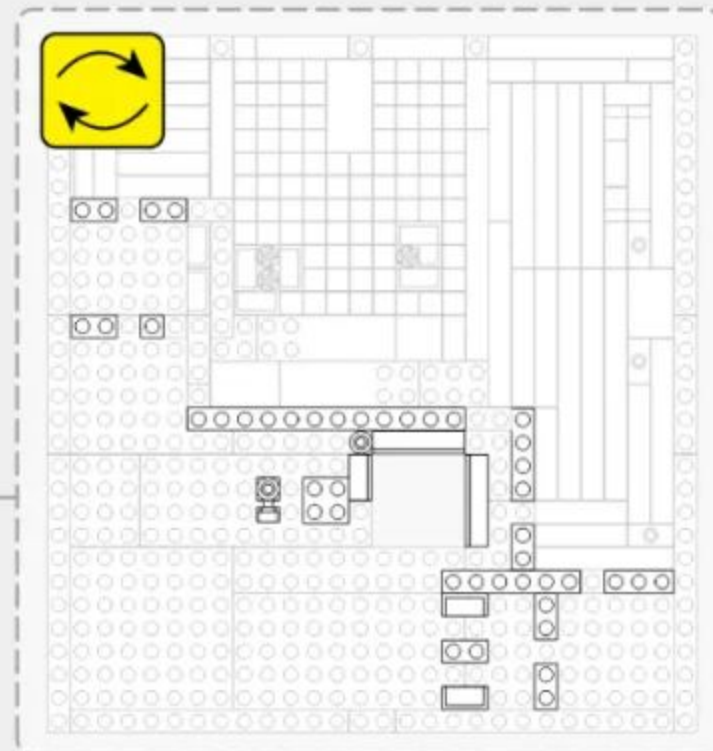
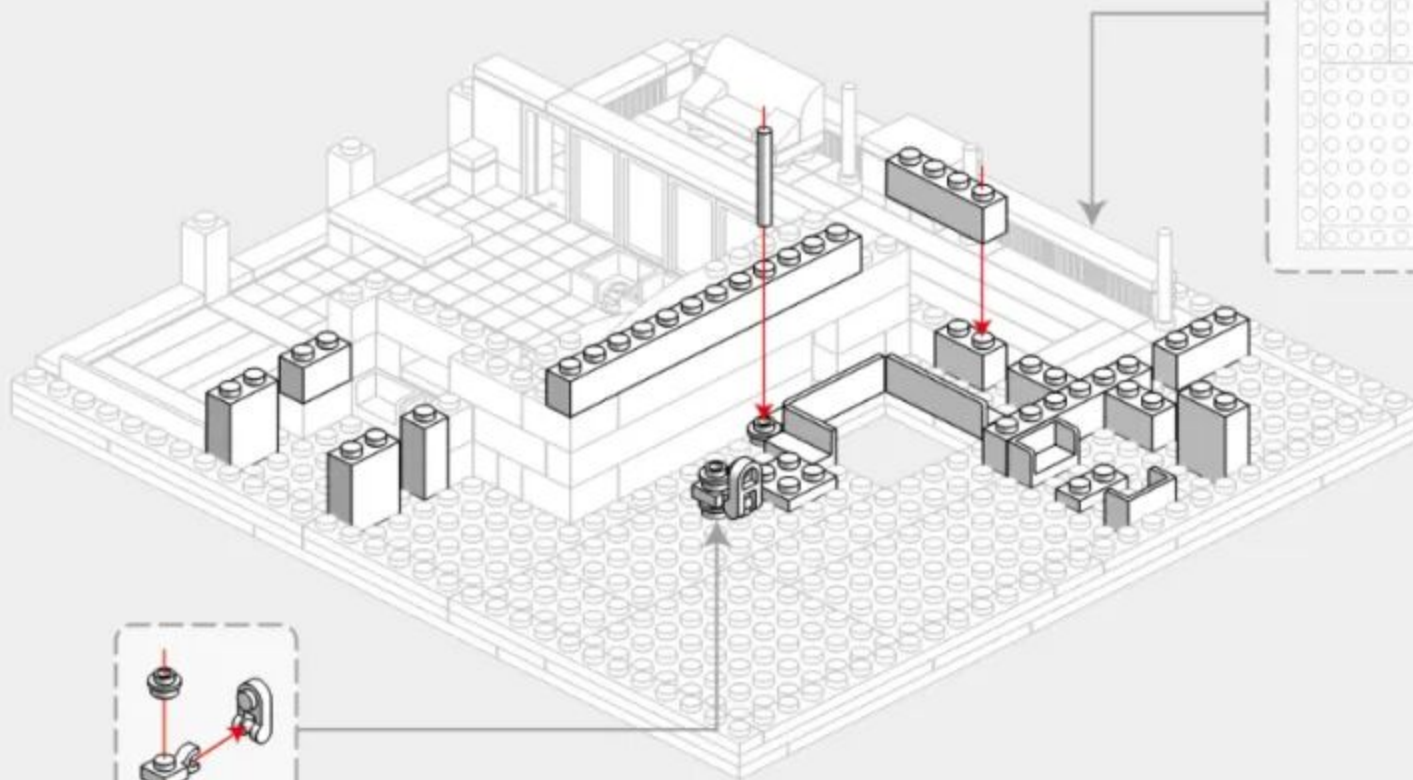
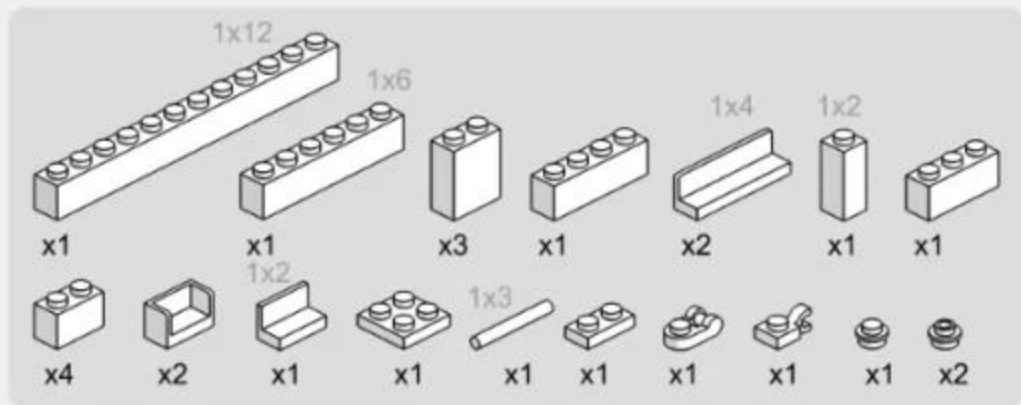

4-3

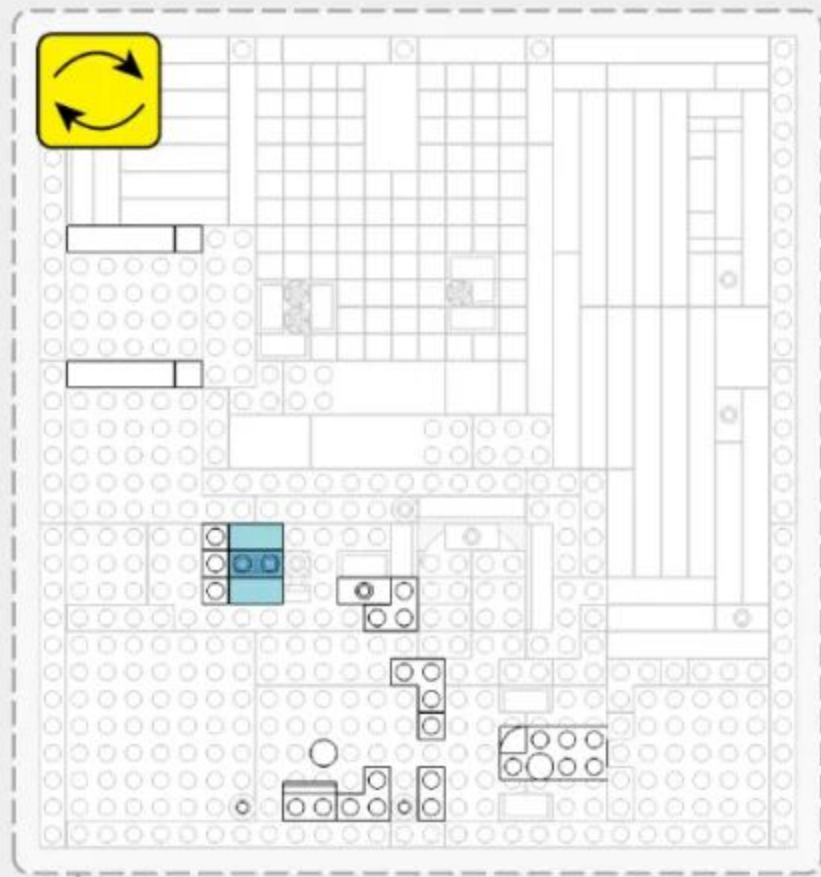
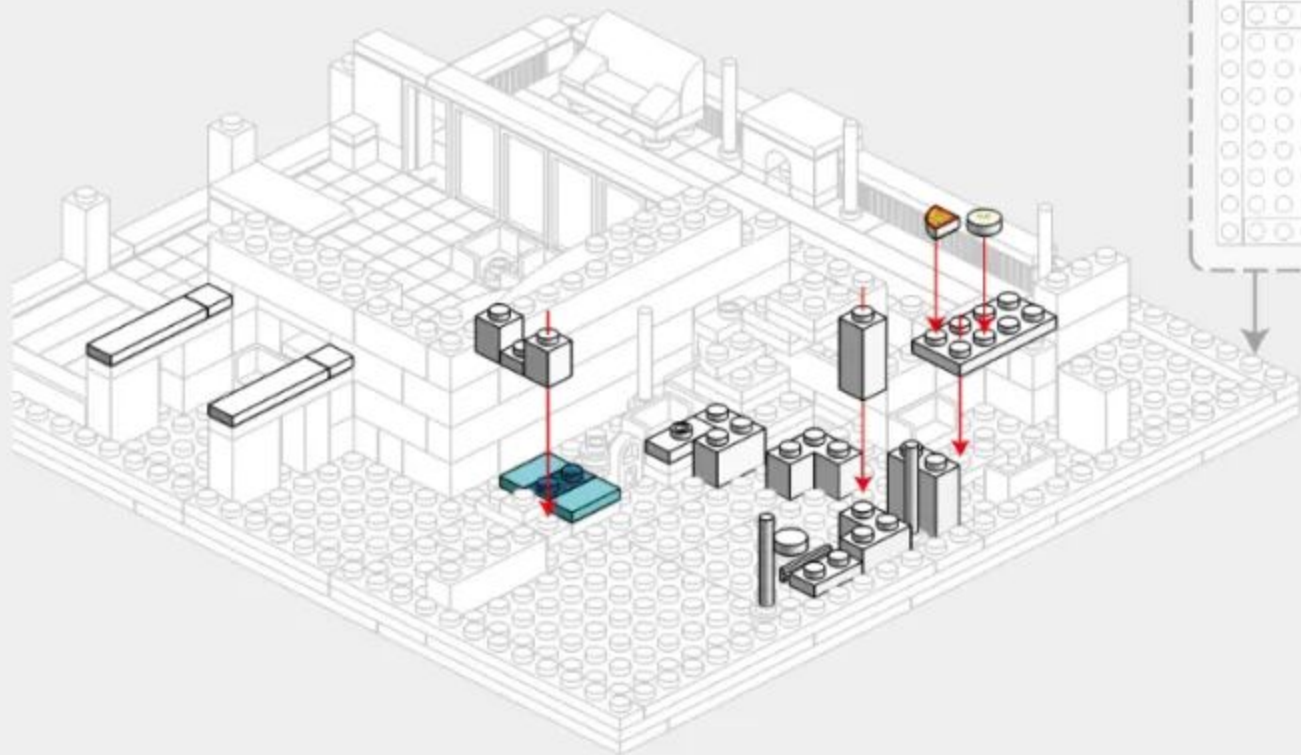
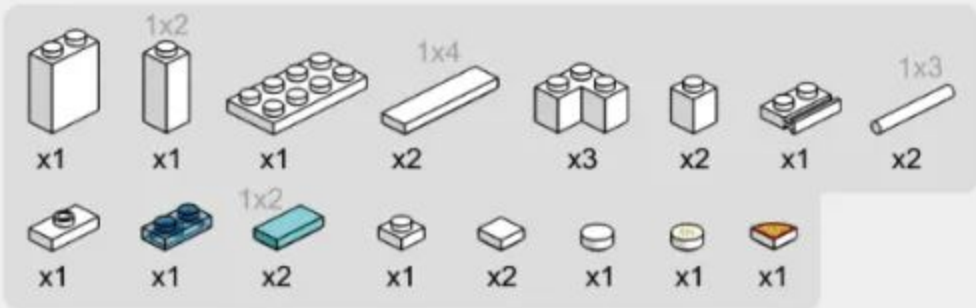

4-4

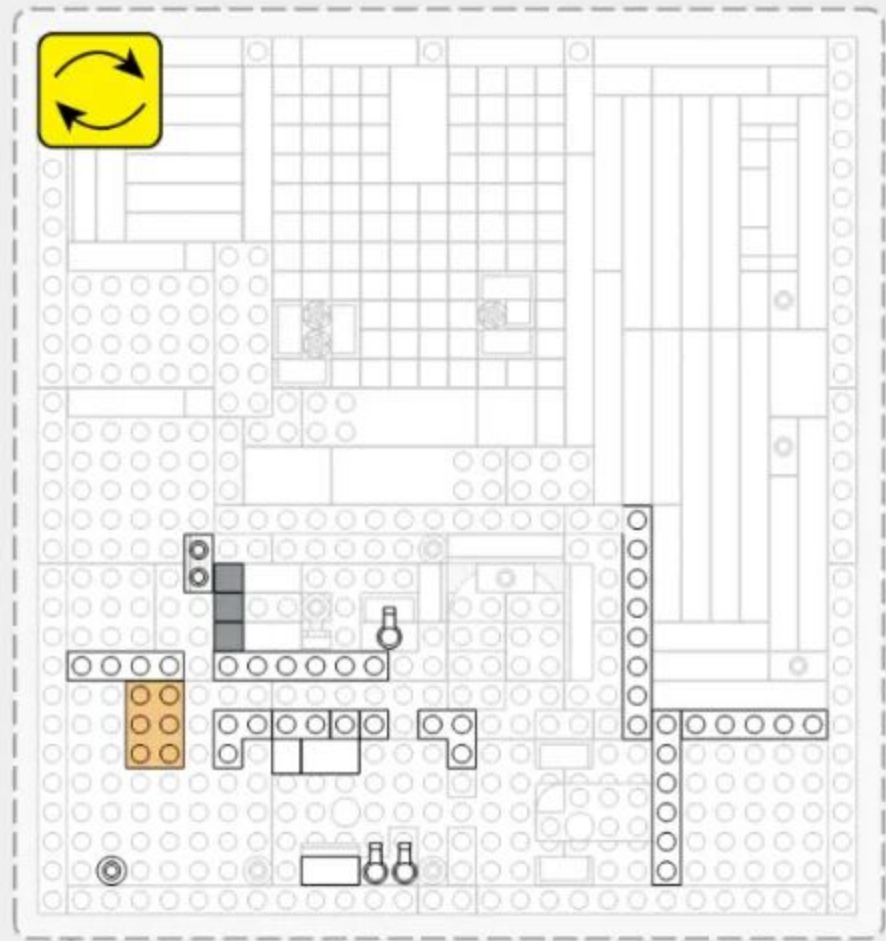
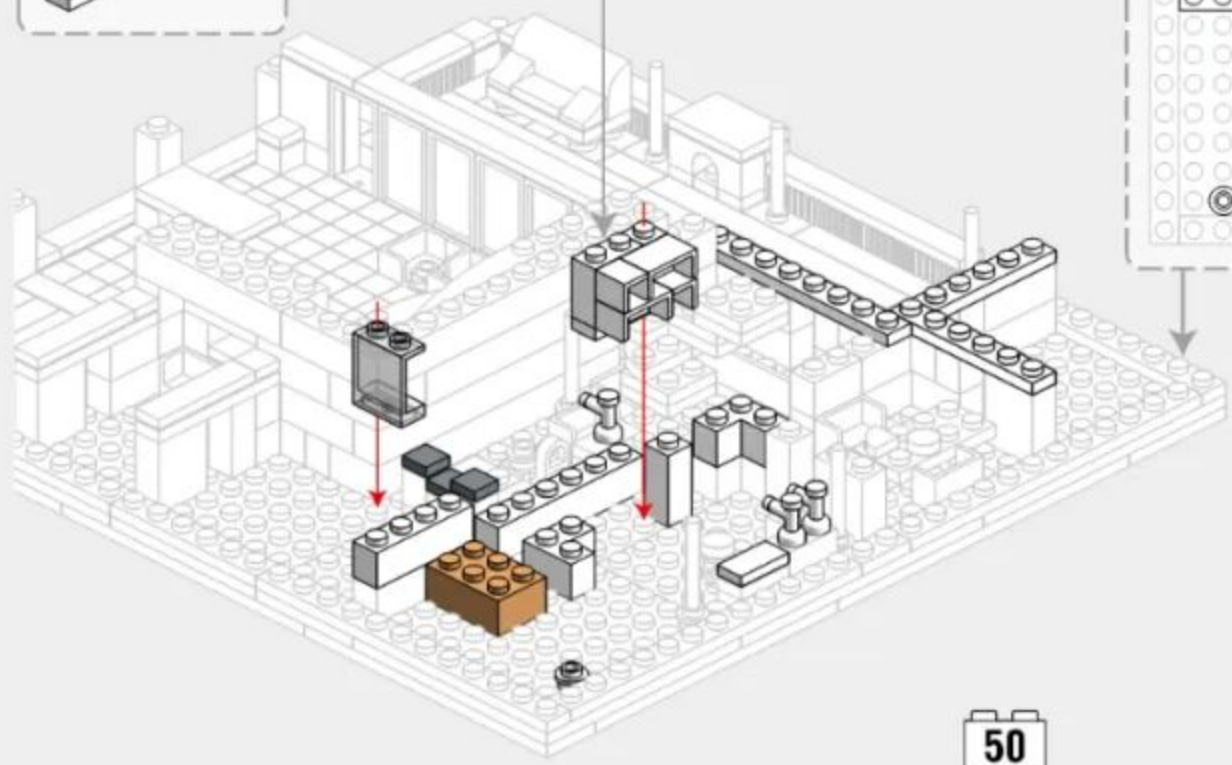
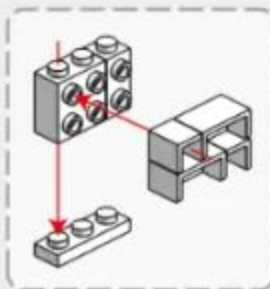
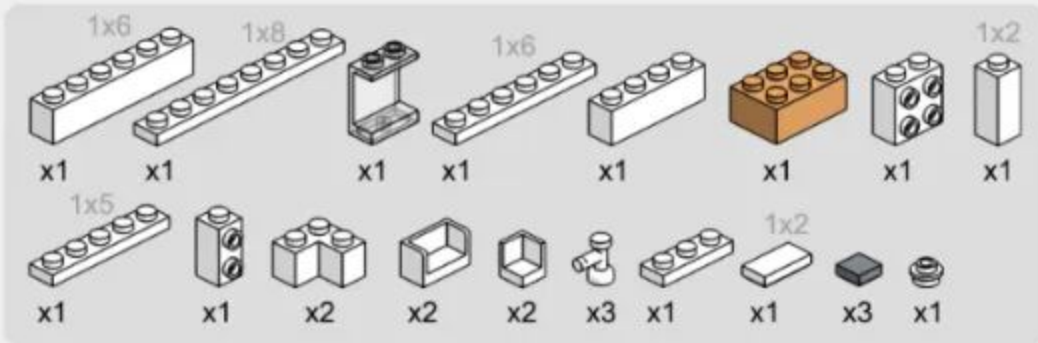

4-7

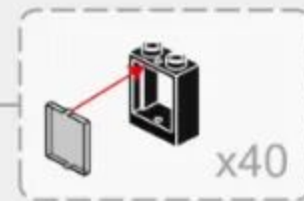
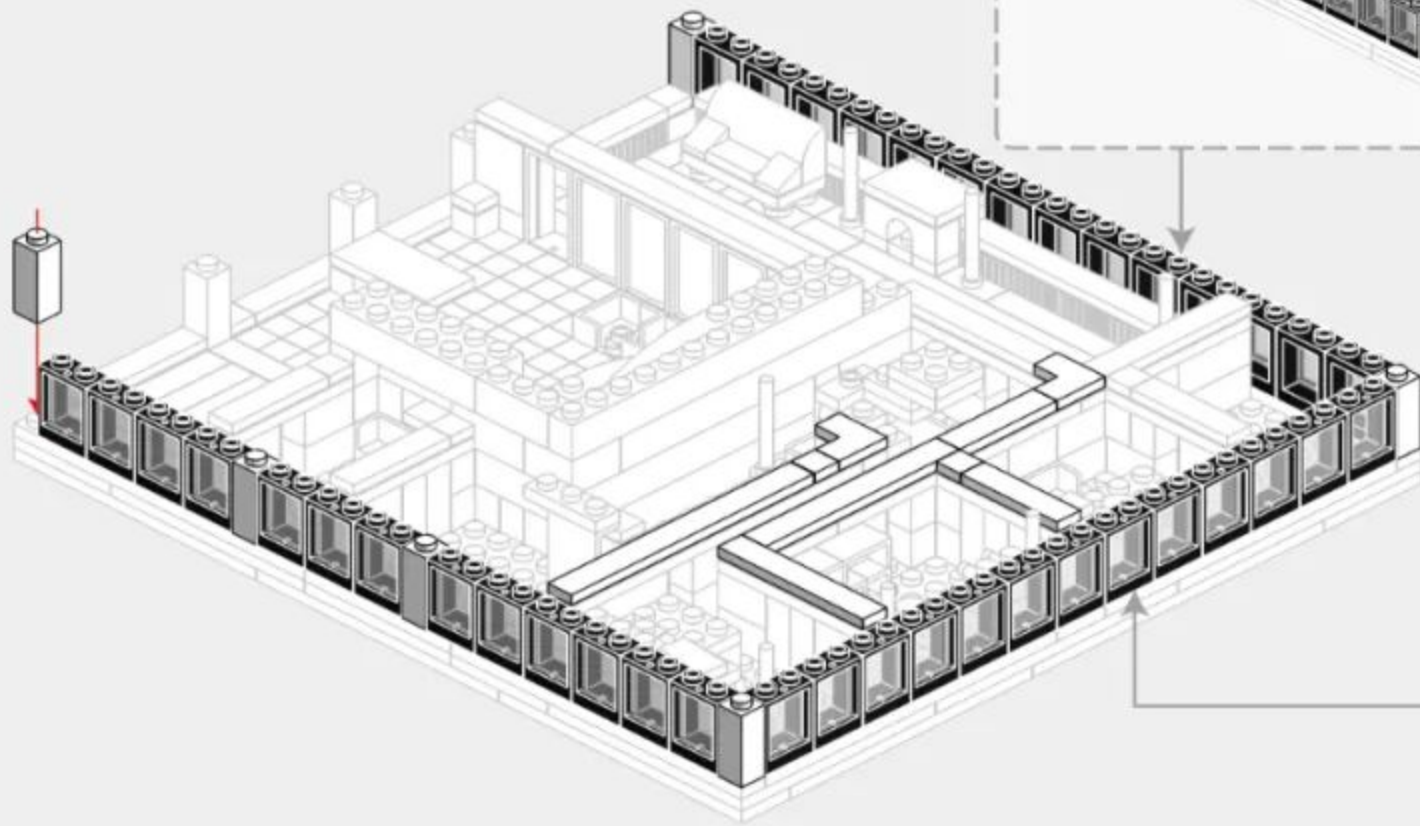
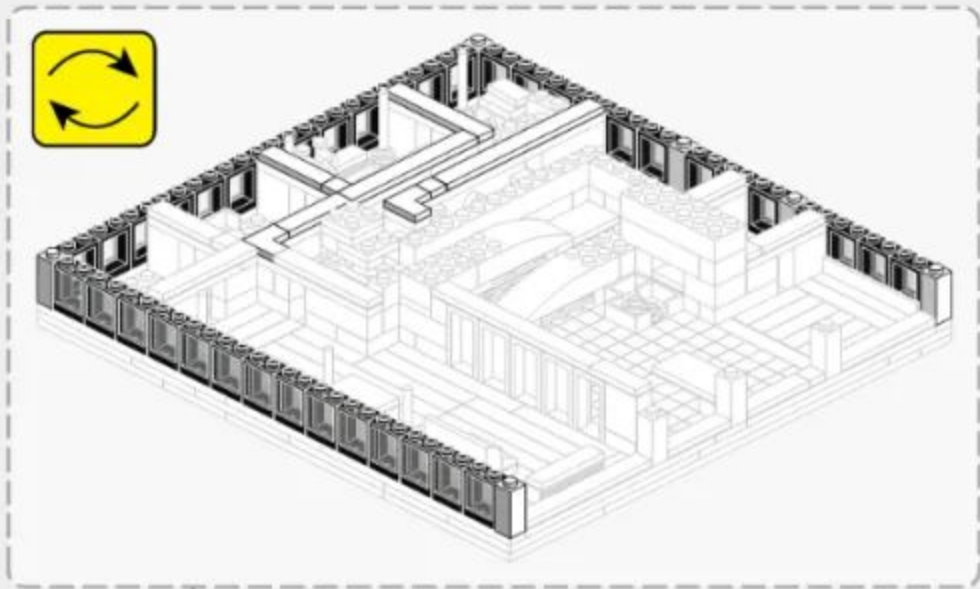
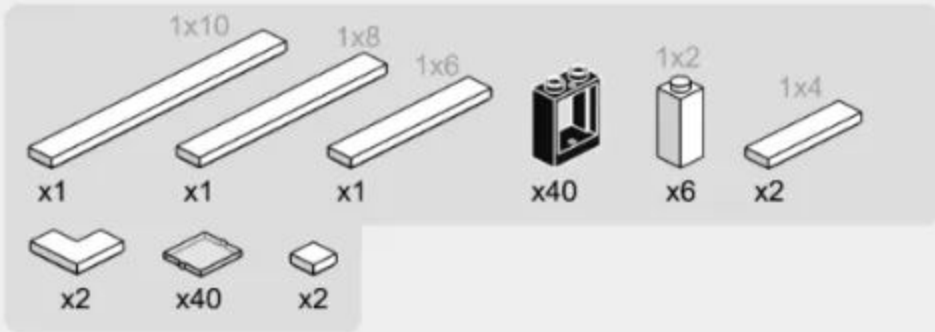

4-8

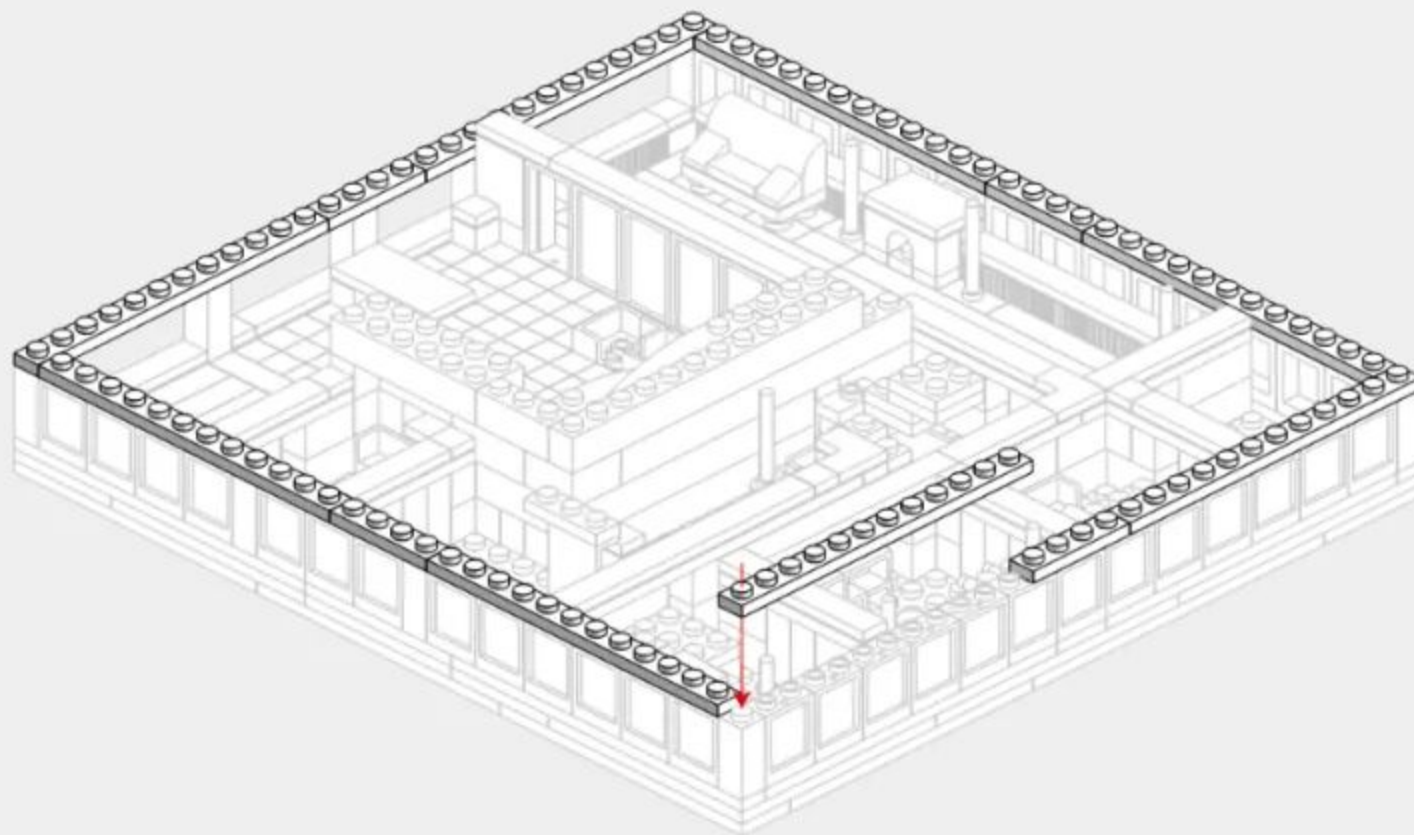
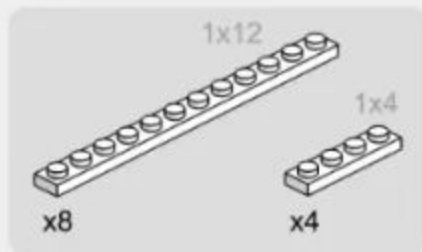

4-9

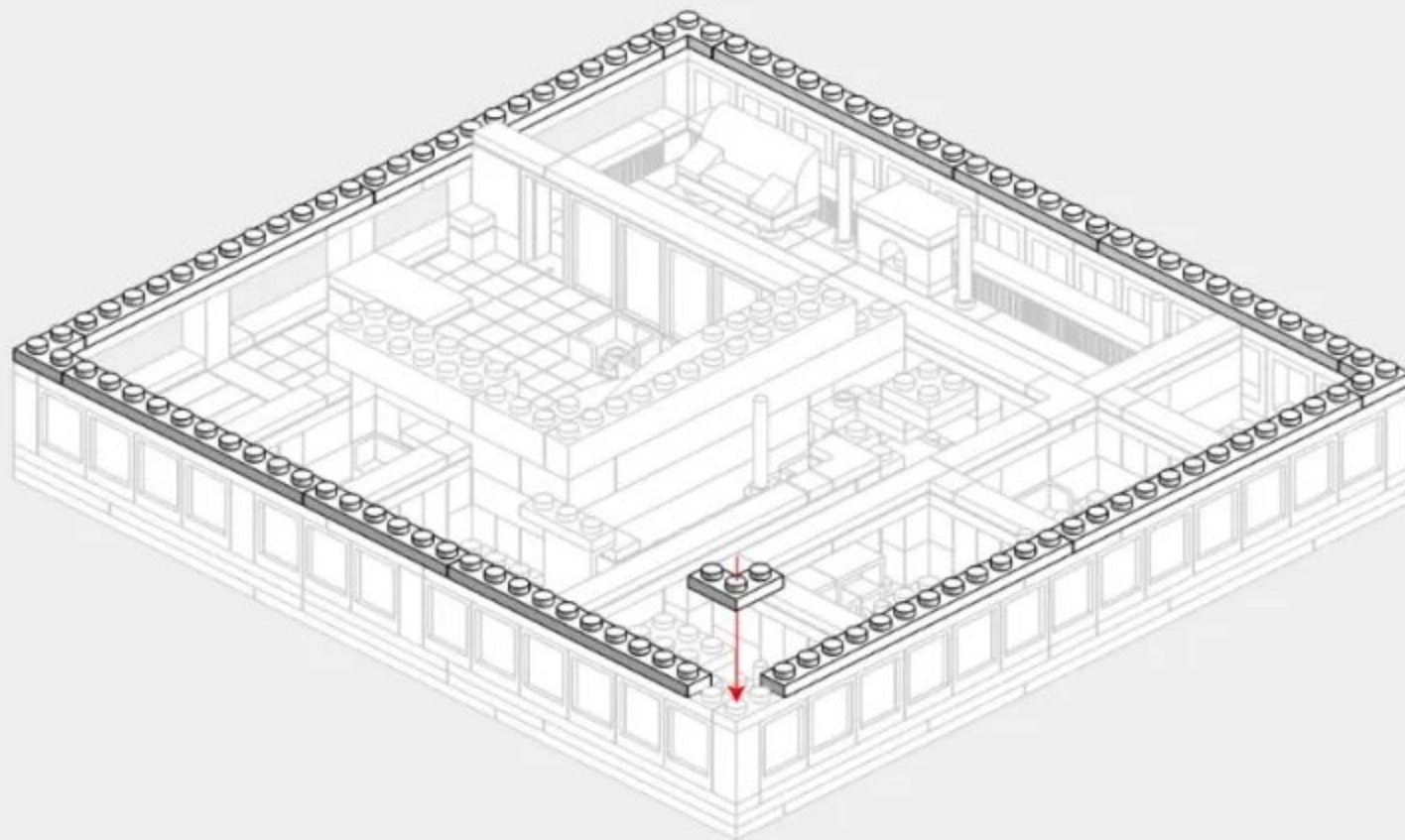
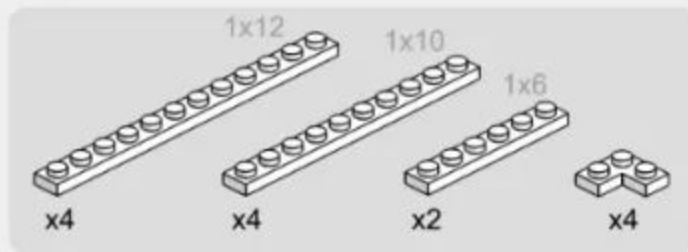

4-10

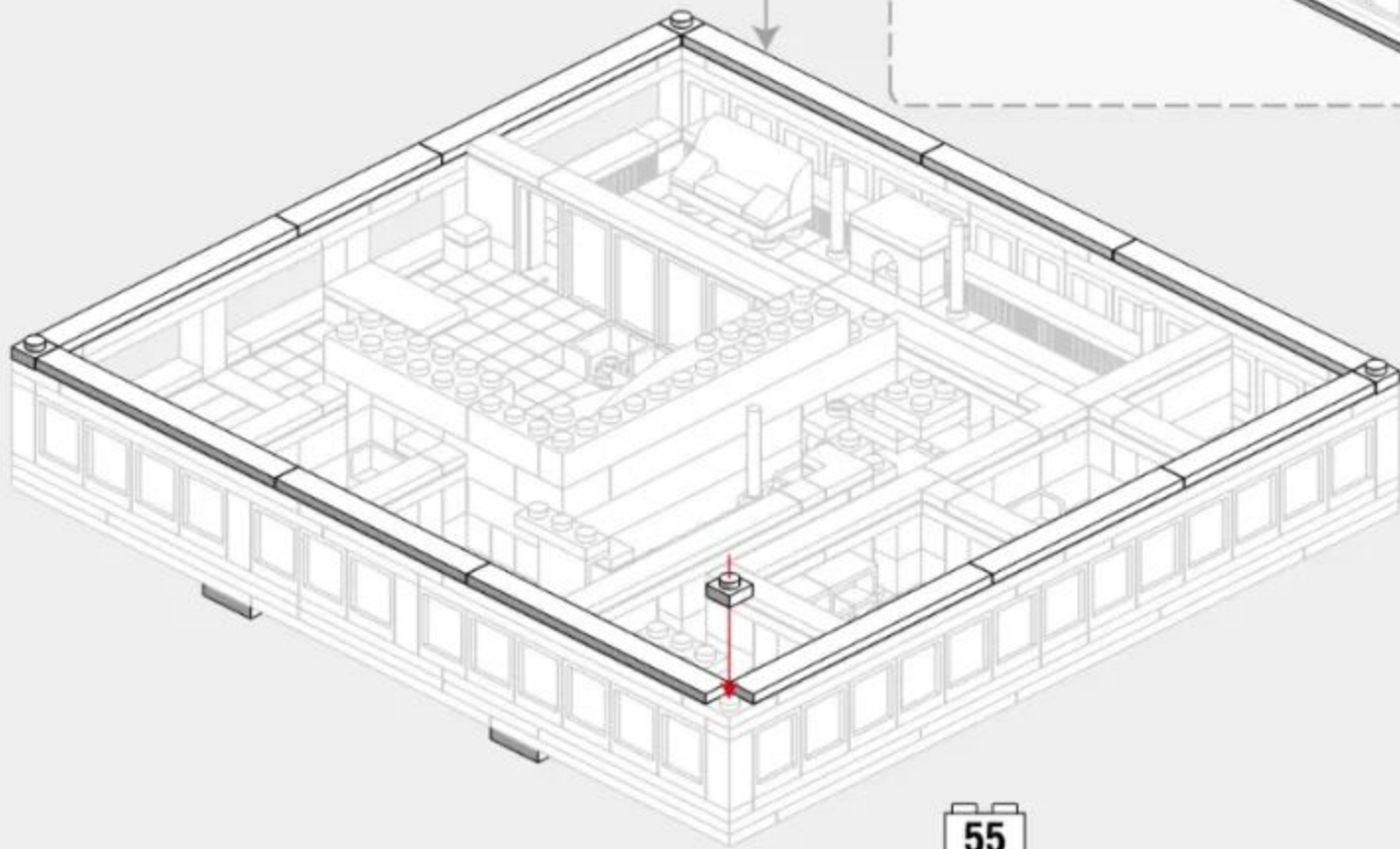
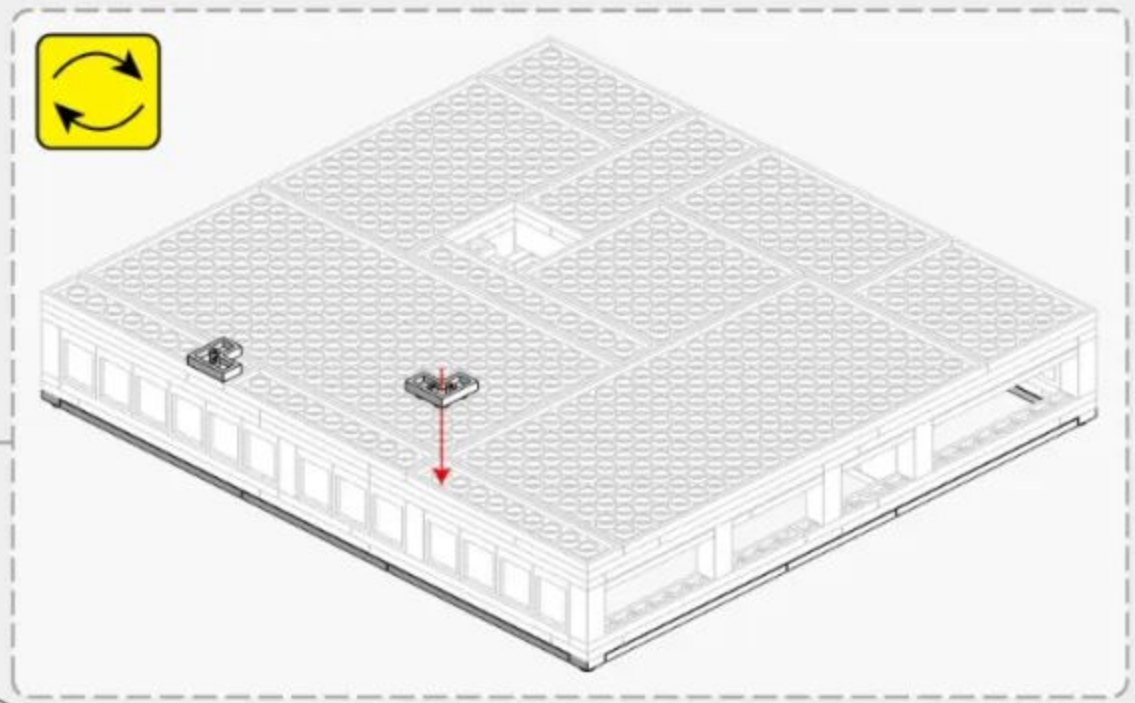
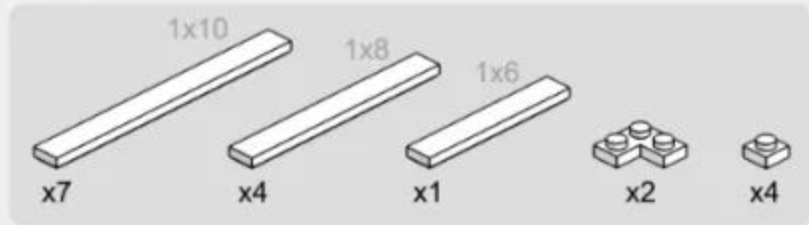

4-11

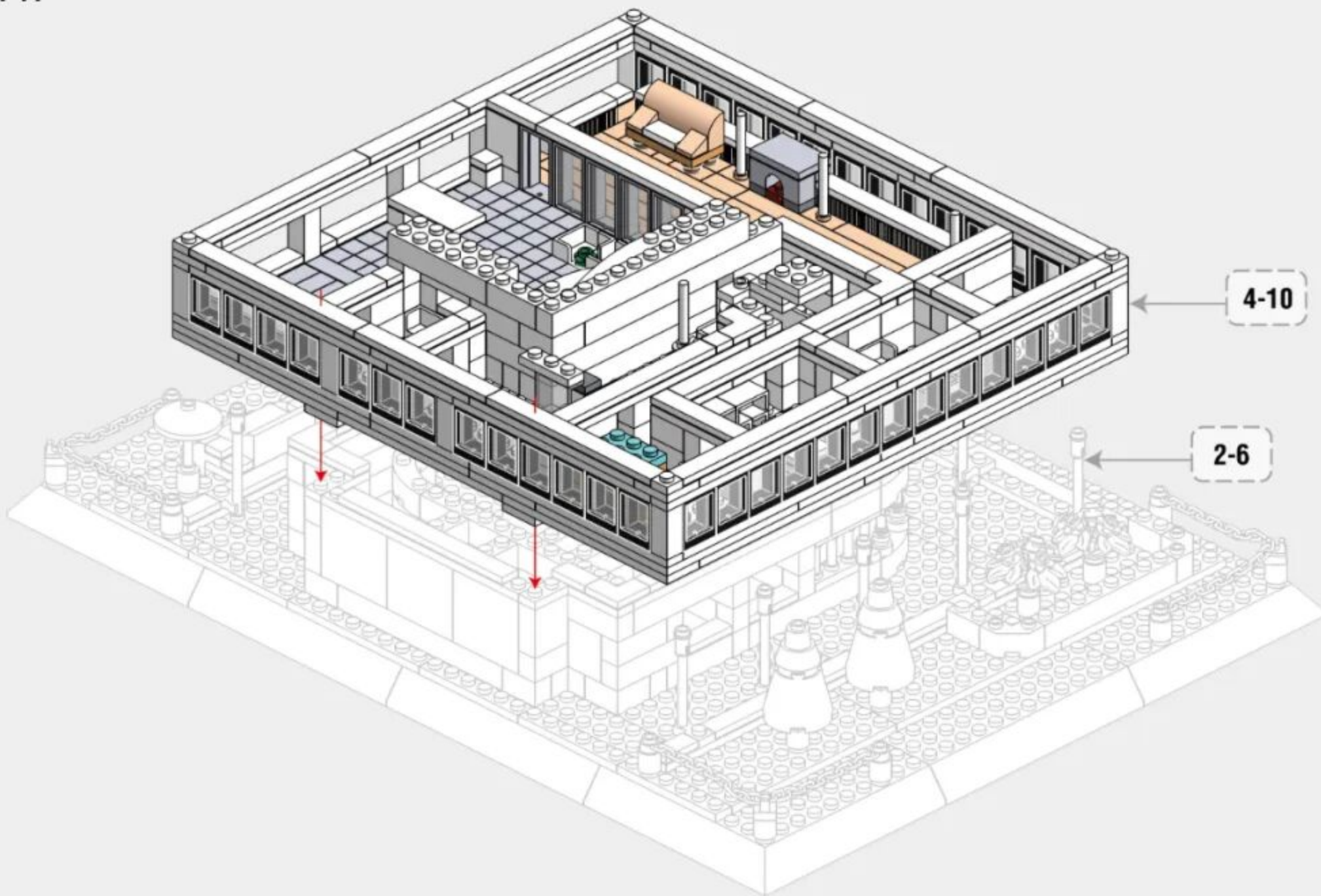

56



229PCS

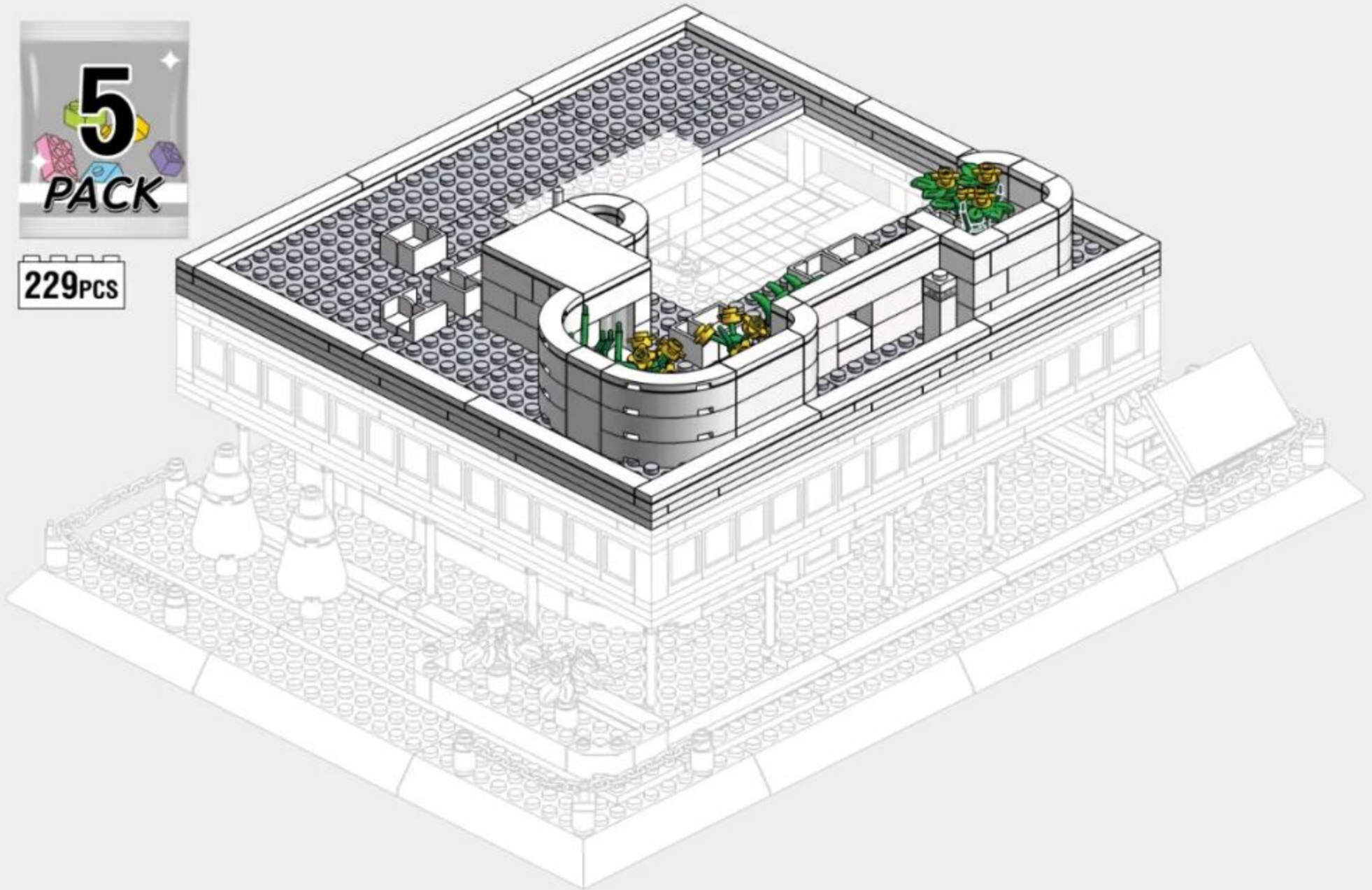

57

5-1

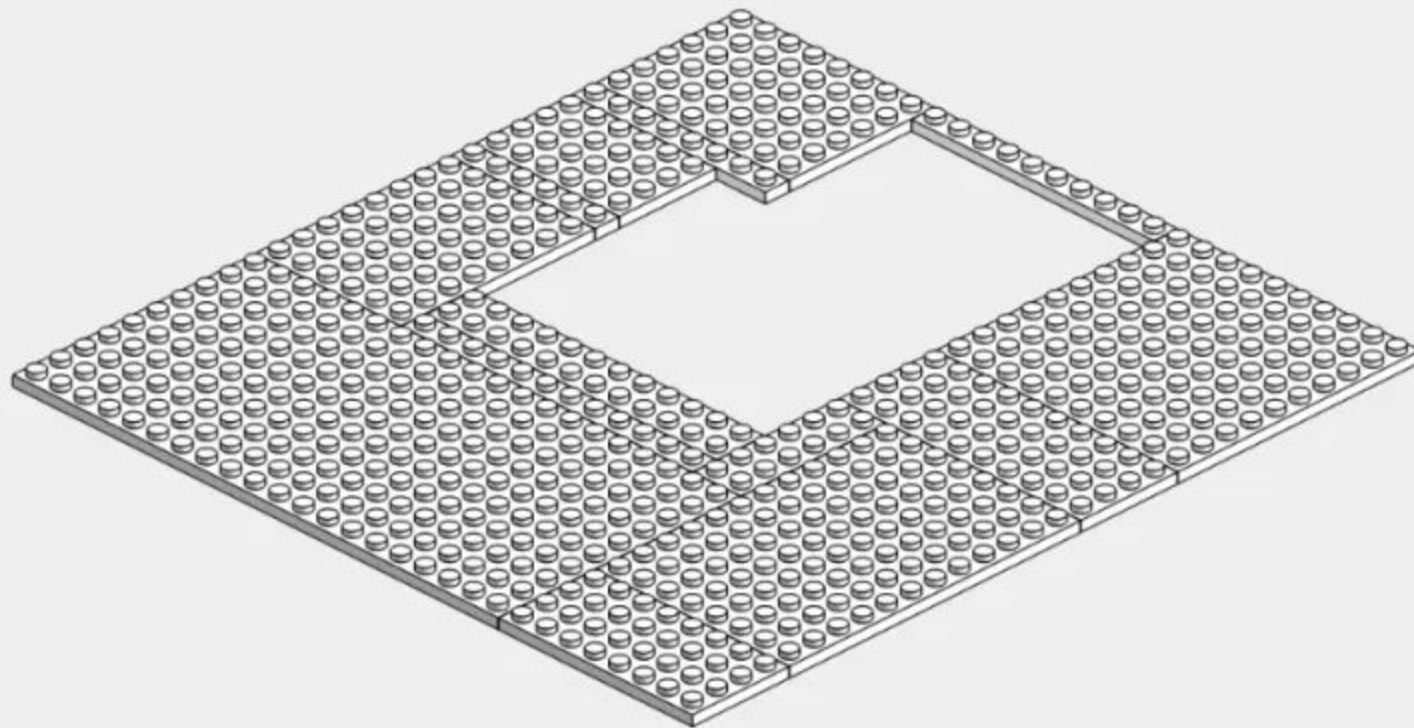
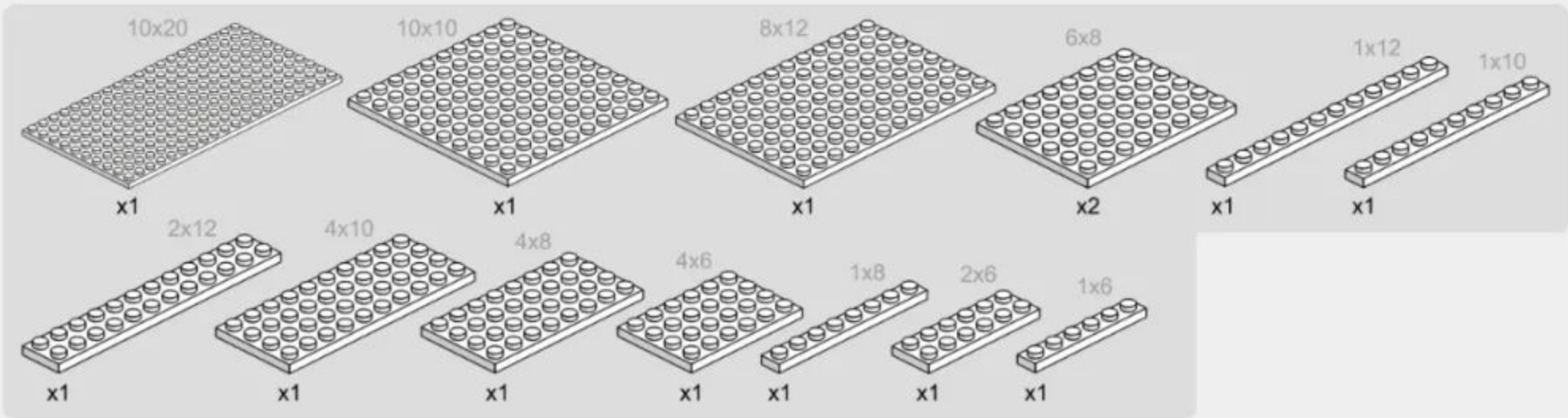

5-2

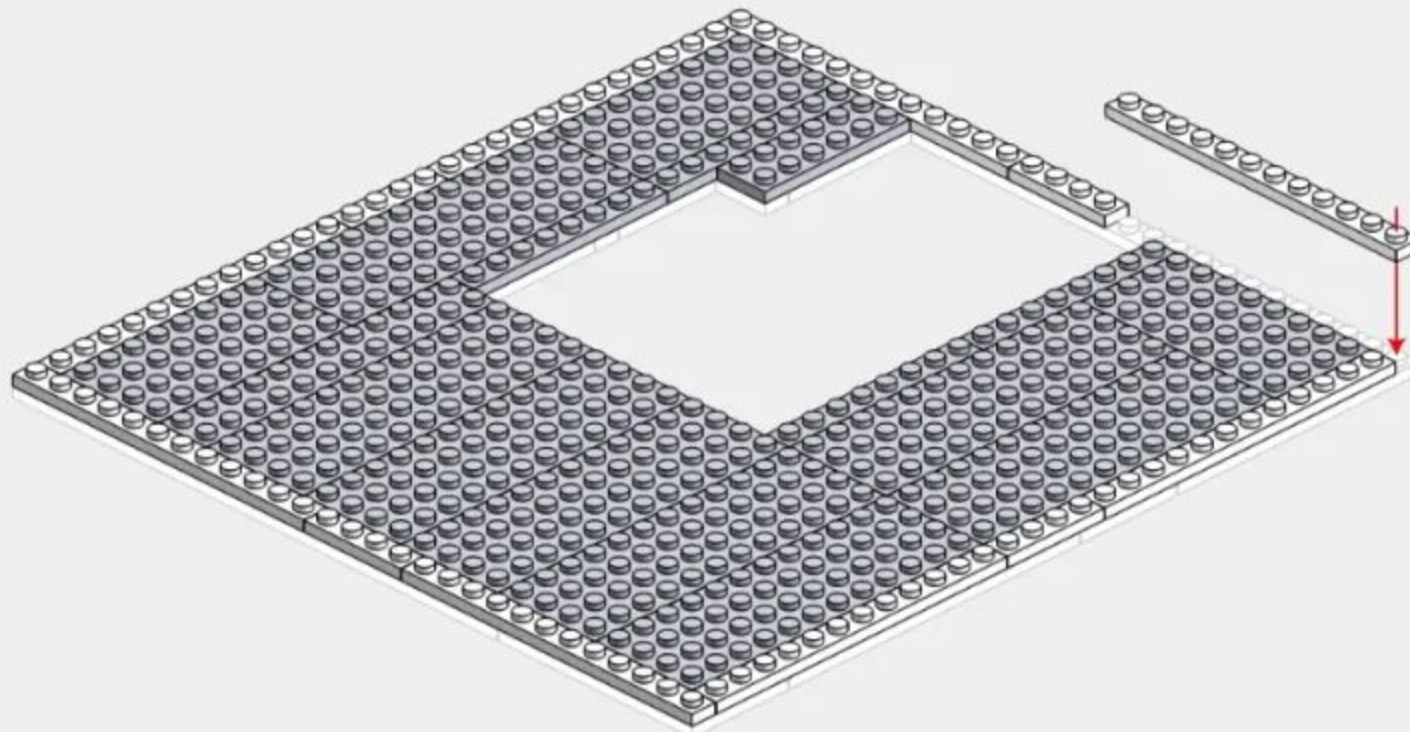
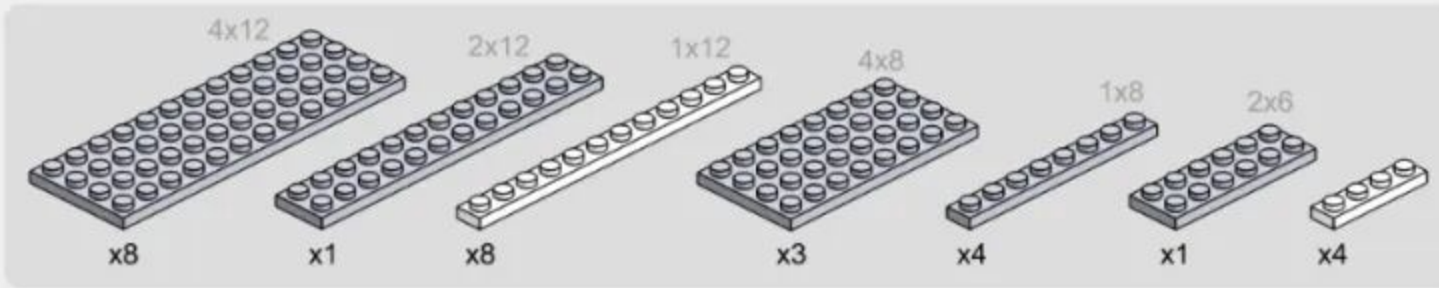

5-3

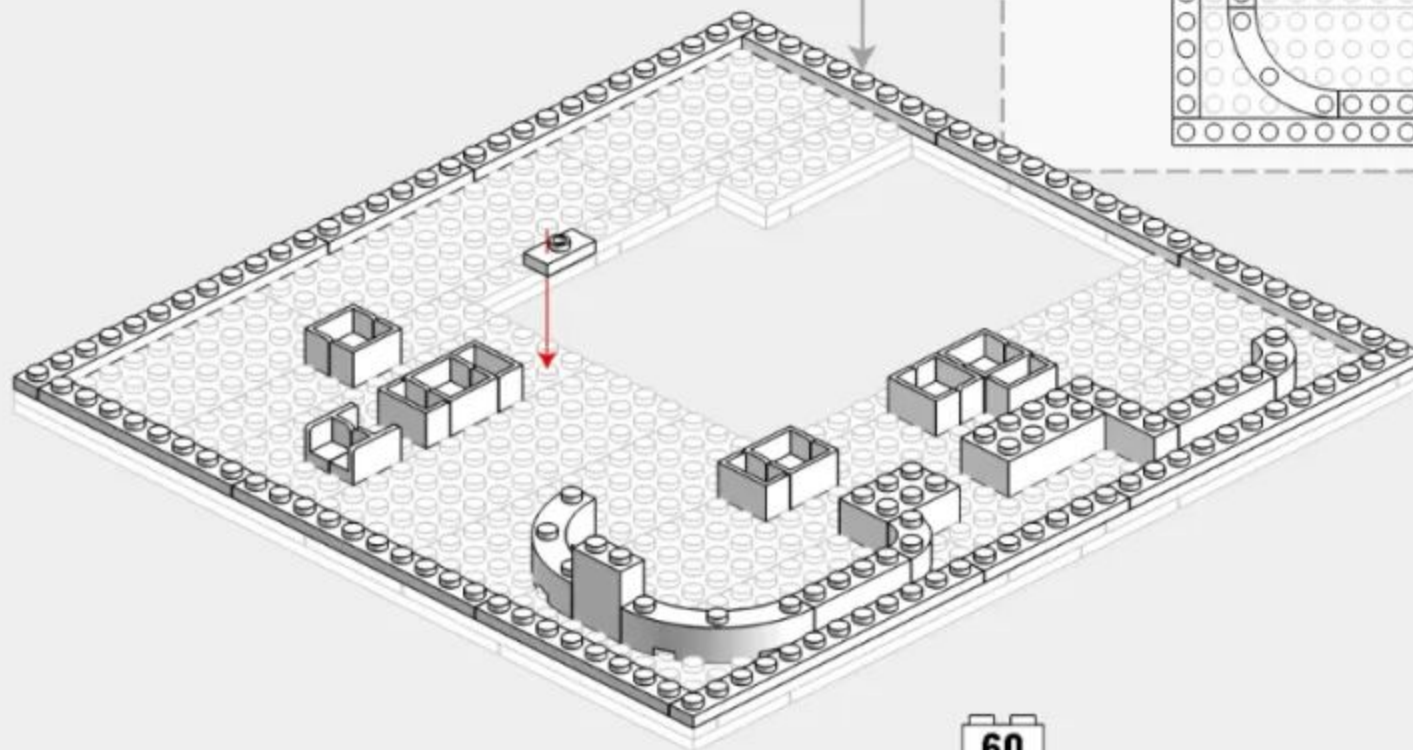
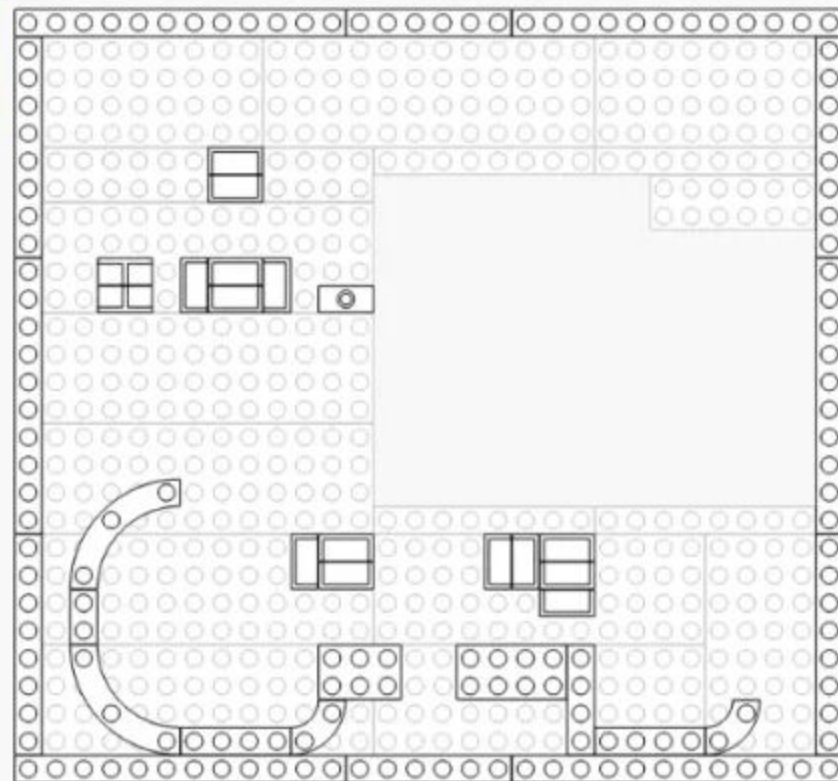
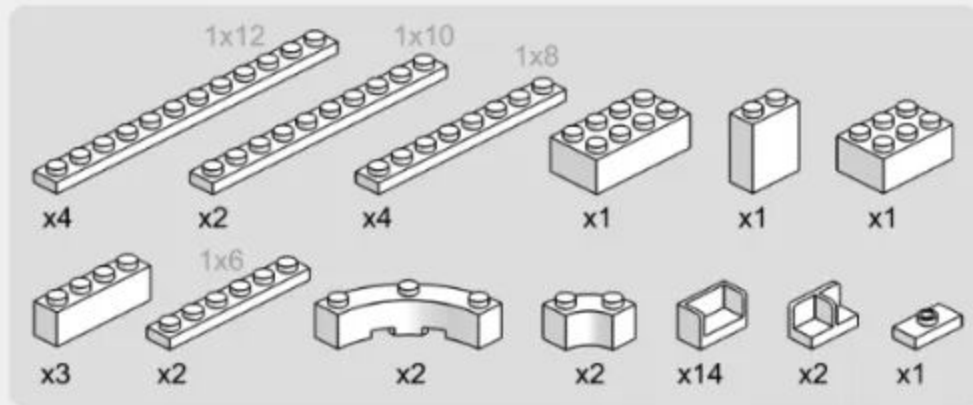

5-5

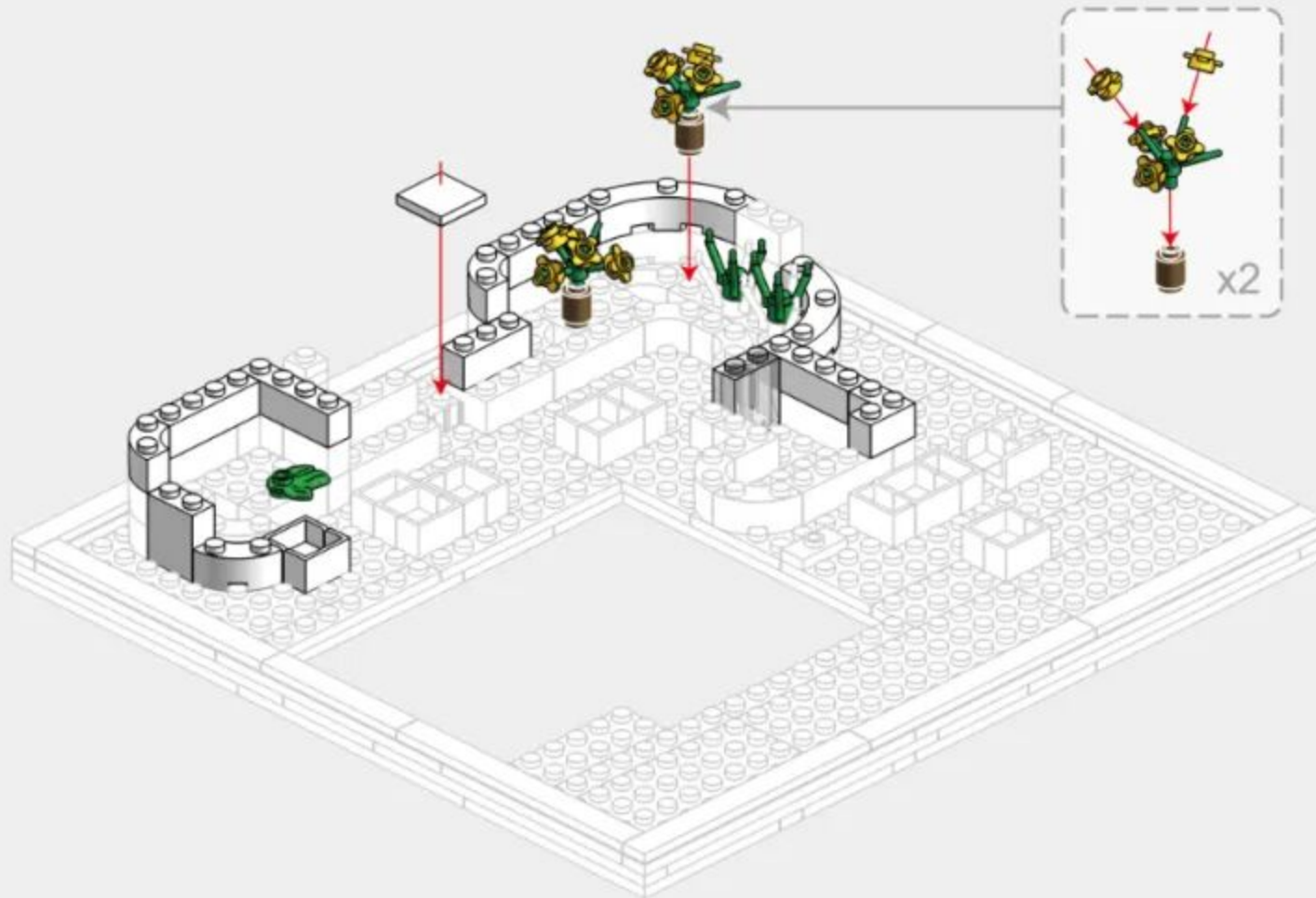
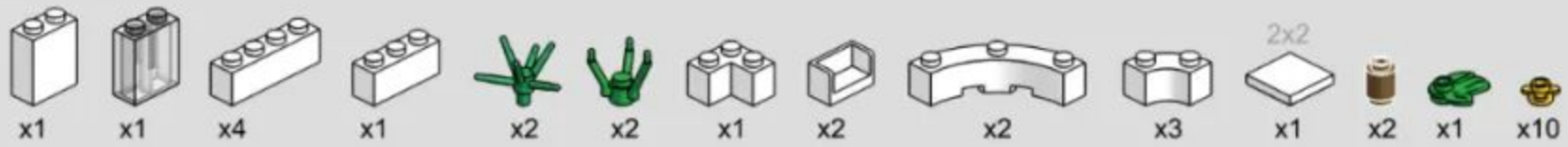

5-6

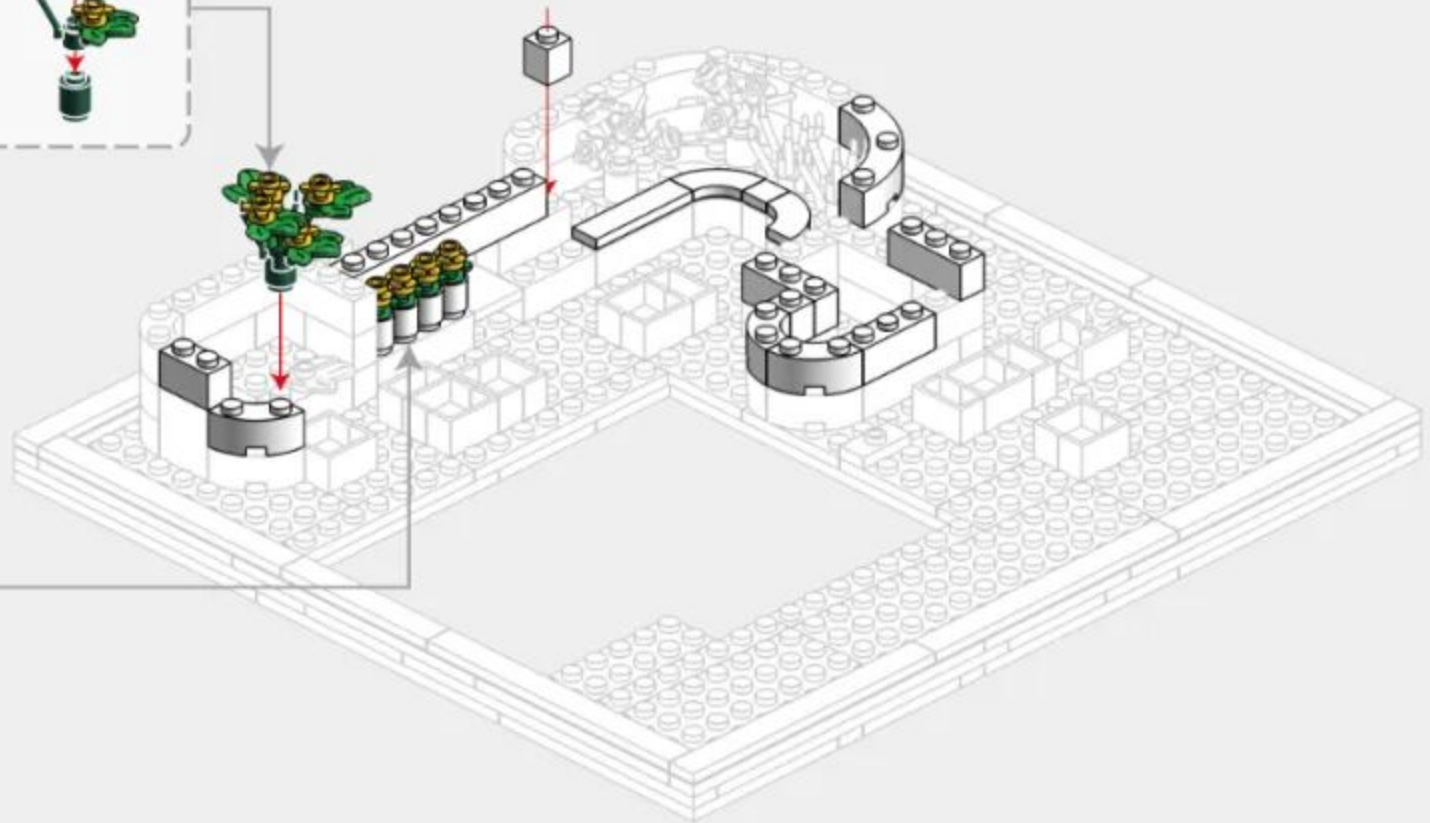
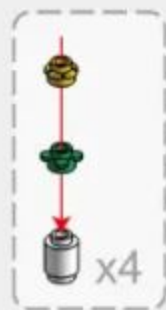
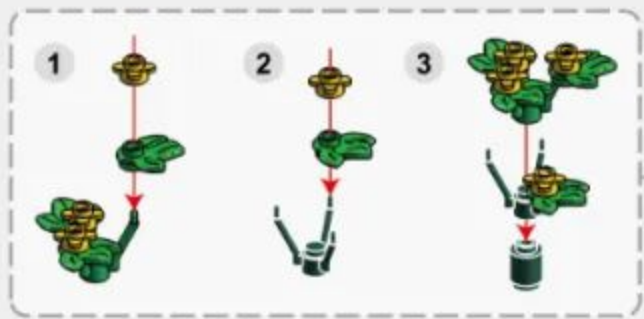
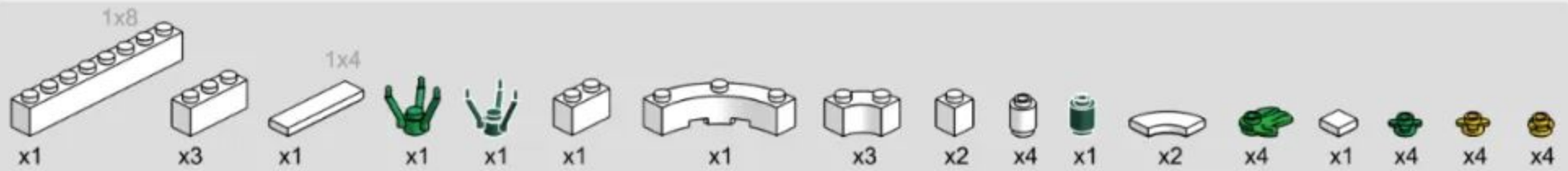

5-7

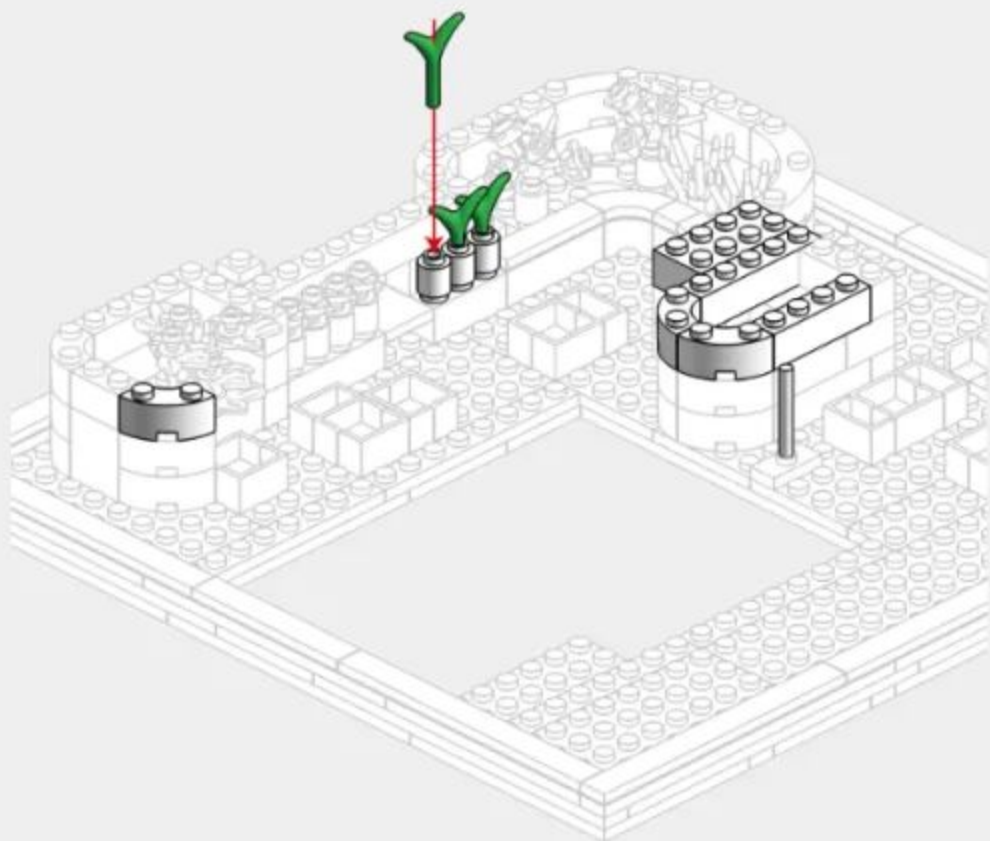
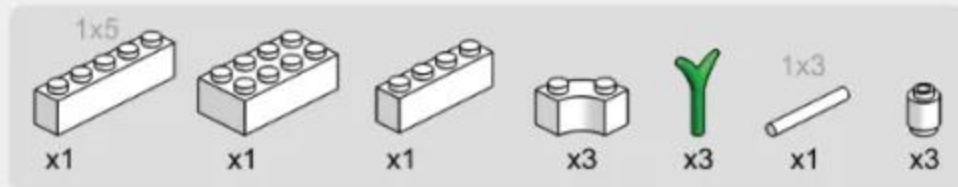

5-8

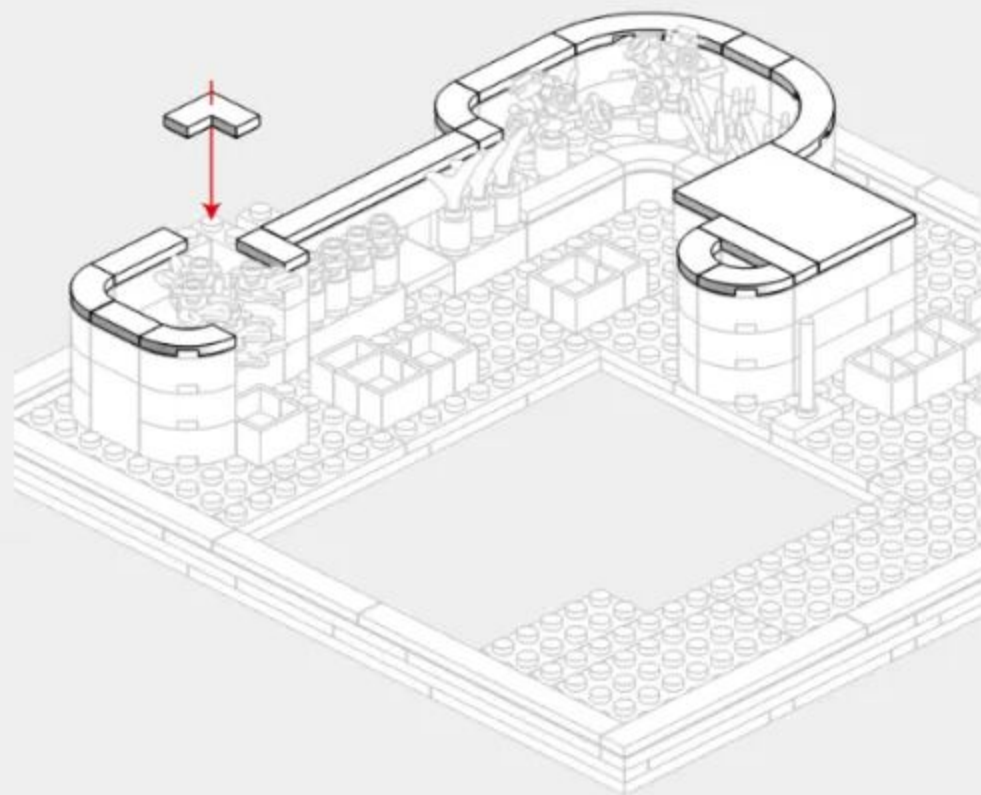
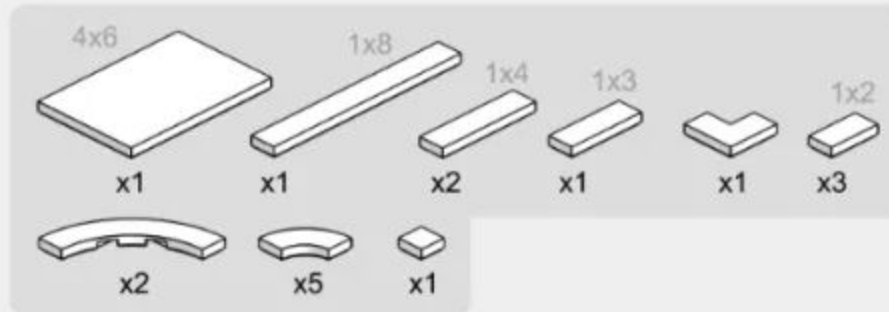

5-9

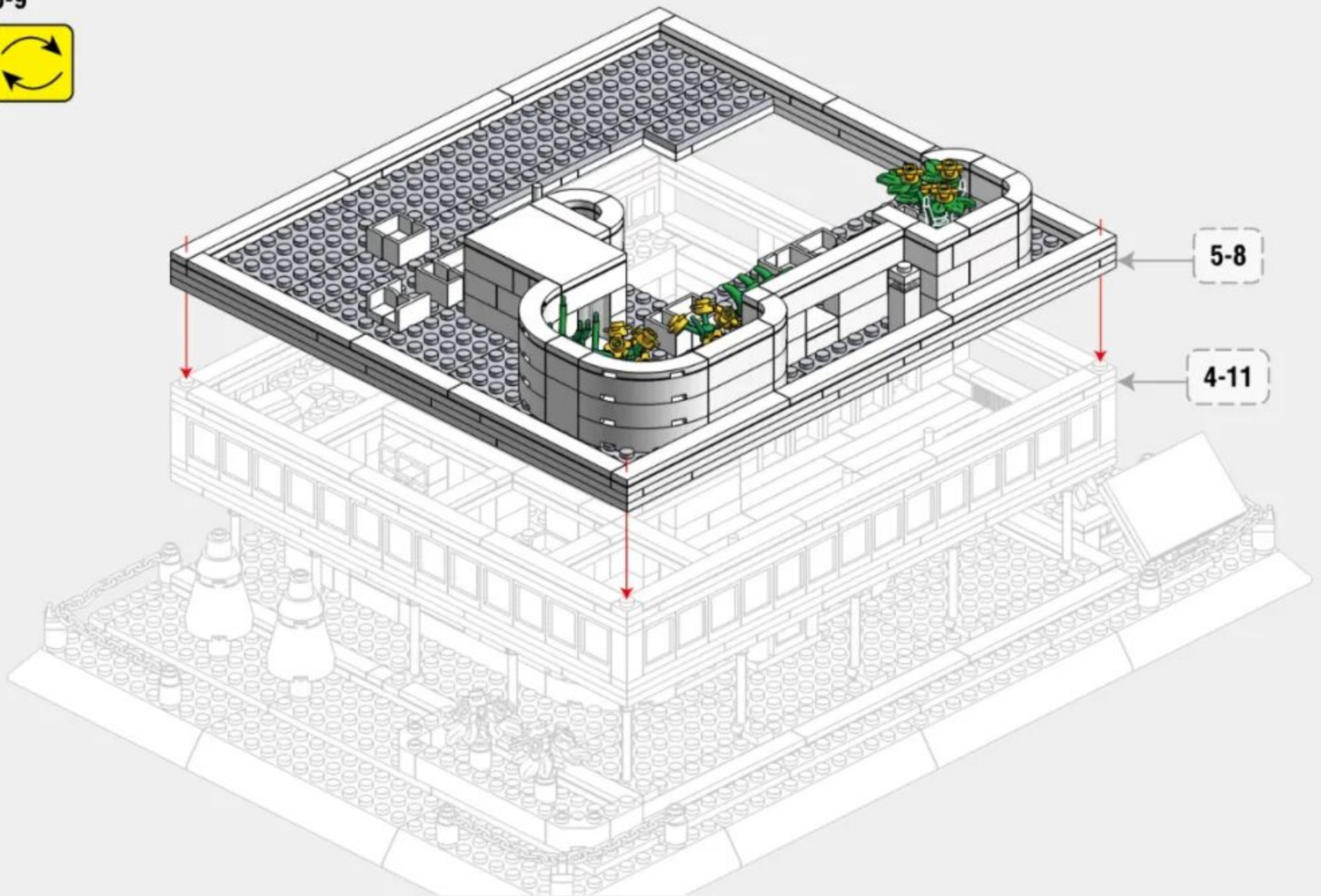

5-10



66

ARCHITECTURE

The World's great architecture



6224 英国伦敦白金汉宫
BUCKINGHAM PALACE-LONDON,ENGLAND



5225 意大利罗马斗兽场
COLOSSEUM-ROME,ITALY



5226 日本东京帝国饭店
IMPERIAL HOTEL-TOKYO,JAPAN



6211 德国柏林勃兰登堡门
BRANDENBURG GATE-BERLIN,GERMANY



6222 中国甘肃长城-嘉峪关
JIAYU PASS-GANSU,CHINA



6212 日本京都清水寺仁王门
NIOMON GATE OF KIYOMIZU-DERA-KYOTO,JAPAN



6214 中国武汉黄鹤楼
YELLOW CRANE TOWER-WUHAN,CHINA



6215 英国伦敦眼
LONDON EYE-LONDON,ENGLAND



6221 中国北京故宫-太和殿
HALL OF SUPREME HARMONY-BEIJING,CHINA



6213 俄罗斯莫斯科瓦西里大教堂
SAINT BASIL'S CATHEDRAL-MOSCOW,RUSSIA



6220 沙特阿拉伯麦加大清真寺
GREAT MOSQUE OF MECCA,SAUDI ARABIA



6219 美国纽约联合国大厦
UNITED NATIONS HEADQUARTERS-NEW YORK,AMERICA



4214 美国华盛顿白宫
WHITE HOUSE-WASHINGTON D.C.,AMERICA



4212 意大利罗马许愿池
TREVİ FOUNTAIN-ROME,ITALY



4213 法国巴黎卢浮宫
MUSÉE DU LOUVRE-PARIS,FRANCE



4218 新加坡-鱼尾狮
MERLION,SINGAPORE



4210 埃及开罗吉萨金字塔
GREAT PYRAMID OF GIZA-CAIRO,EGYPT



4219 英国伦敦双子塔桥
TOWER BRIDGE-LONDON,ENGLAND



4216 美国华盛顿林肯纪念堂
LINCOLN MEMORIAL-WASHINGTON D.C.,AMERICA



4217 新加坡-金沙酒店
MARINA BAY SANDS,SINGAPORE



7210 中国上海世博会中国馆
CHINA PAVILION AT EXPO-SHANGHAI, CHINA



4221 加拿大渥太华国会山庄
PARLIAMENT BUILDINGS-OTTAWA, CANADA



4211 英国伦敦伊丽莎白塔
ELIZABETH TOWER-ENGLAND



4220 美国纽约熨斗大厦
FLATIRON BUILDING-NEW YORK, AMERICA



5227 美国纽约自由女神像
STATUE OF LIBERTY-NEW YORK, AMERICA



4215 加拿大多伦多电视塔
THE CN TOWER-CANADA



4222 阿联酋迪拜哈利法塔
THE BURJ KHALIFA TOWER-DUBAI, UAE



5224 中国上海东方明珠广播电视塔
ORIENTAL PEARL TOWER-SHANGHAI, CHINA



5212 美国纽约帝国大厦
EMPIRE STATE BUILDING-NEW YORK, AMERICA



5213 马来西亚吉隆坡石油双塔
PETRONAS TWIN TOWERS-KUALA LUMPUR, MALAYSIA



5214 意大利托斯卡纳比萨斜塔
LEANING TOWER OF PISA-TUSCANY, ITALY



5216 英国伦敦伊丽莎白塔
ELIZABETH TOWER LONDON, ENGLAND



5219 俄罗斯莫斯科克里姆林宫钟楼
SPASSKAYA TOWER-MOSCOW, RUSSIA



5220 阿联酋迪拜卓美亚帆船酒店
BURJ AL ARAB HOTEL-DUBAI, UAE



5217 法国巴黎埃菲尔铁塔
EIFFEL TOWER-PARIS, FRANCE



5221 中国台北101大楼
TAIPEI 101-TAIPEI, CHINA



6223 中国武汉长江大桥
WUHAN YANGTZE RIVER BRIDGE



5210 法国巴黎圣母院大教堂
CATHÉDRALE NOTRE DAME DE PARIS-PARIS,FRANCE



5223 法国巴黎凯旋门
ARC DE TRIOMPHE-PARIS,FRANCE



5211 印度阿格拉泰姬陵
TAJ MAHAL-AGRA,INDIA



5215 英国伦敦双子塔桥
TOWER BRIDGE-LONDON,ENGLAND



5222 中国北京天坛祈年殿
HALL OF PRAYER FOR GOOD HARVESTS-BEIJING,CHINA



6210 美国旧金山金门大桥
GOLDEN GATE BRIDGE-SAN FRANCISCO,AMERICA



6216 中国北京万里长城（八达岭）
THE GREAT WALL-BEIJING,CHINA



5218 中国北京天安门
TIAN'ANMEN TOWER-BEIJING,CHINA



6217 中国西藏布达拉宫
POTALA PALACE-TIBET,CHINA



6218 芬兰罗瓦涅米圣诞老人办公室
SANTA CLAUS OFFICE-ROVANIEMI,FINLAND



6225 墨西哥库库尔坎玛雅金字塔
EL CASTILLO-KUKULKAN,MEXICO



6226 德国巴伐利亚新天鹅堡
SCHLOSS NEUSCHWANSTEIN, BAYERN, DEUTSCHLAND



5228 美国芝加哥威利斯大厦
WILLIS TOWER-CHICAGO, AMERICA



5229 土耳其伊斯坦布尔其少女塔
MAIDEN TOWER-ISTANBUL,TURKEY



5230 中国湖南长沙爱晚亭
AIWAN TING PAVILION-HUNAN,CHINA



5231 巴西里约热内卢救世基督像
CRISTO REDENTOR-RIO DE JANEIRO, BRASIL



5232 美国宾夕法尼亚州流水别墅
FALLINGWATER-PENNSYLVANIA, AMERICA



5233 美国芝加哥范斯沃斯住宅
FARNSWORTH HOUSE-CHICAGO, AMERICA



5234 美国华盛顿唐人街
CHINA TOWN-WASHINGTON, D.C., AMERICA



3210 美国纽约自由女神像
STATUE OF LIBERTY-NEW YORK, AMERICA



4223 中国北京清华园
TSINGHUA CAMPUS-BEIJING, CHINA



7211 中国湖南岳阳楼
YUEYANG TOWER-HUNAN, CHINA



8210 澳大利亚悉尼歌剧院
SYDNEY OPERA HOUSE-BENNELONG POINT, AUSTRALIA



7212 中国江西滕王阁
PAVILION OF PRINCE TENG-JIANGXI, CHINA



6227 中国河南少林寺
SHAOLIN TEMPLE-HENAN, CHINA



7213 中国重庆洪崖洞
HONGYADONG-CHONGQING, CHINA



5235 美国国会大厦
UNITED STATES CAPITOL-WASHINGTON, D.C., AMERICA



5236 中国安徽醉翁亭
ZUIWENG PAVILION-ANHUI, CHINA



6228 中国陕西西安钟楼
XI'AN BELL TOWER-SHAANXI, CHINA



5238 西雅图太空针塔
SPACE NEEDLE-SEATTLE, WASHINGTON, AMERICA



5237 法国巴黎萨伏伊别墅
VILLA SAVOYE-PARIS, FRANCE

VILLA SAVOYE

COUNTRY: France

CITY: Paris



微信扫一扫
补件更简单

