



LIZIBA STATION

中国重庆李子坝站

Chongqing, China

The world's great architecture

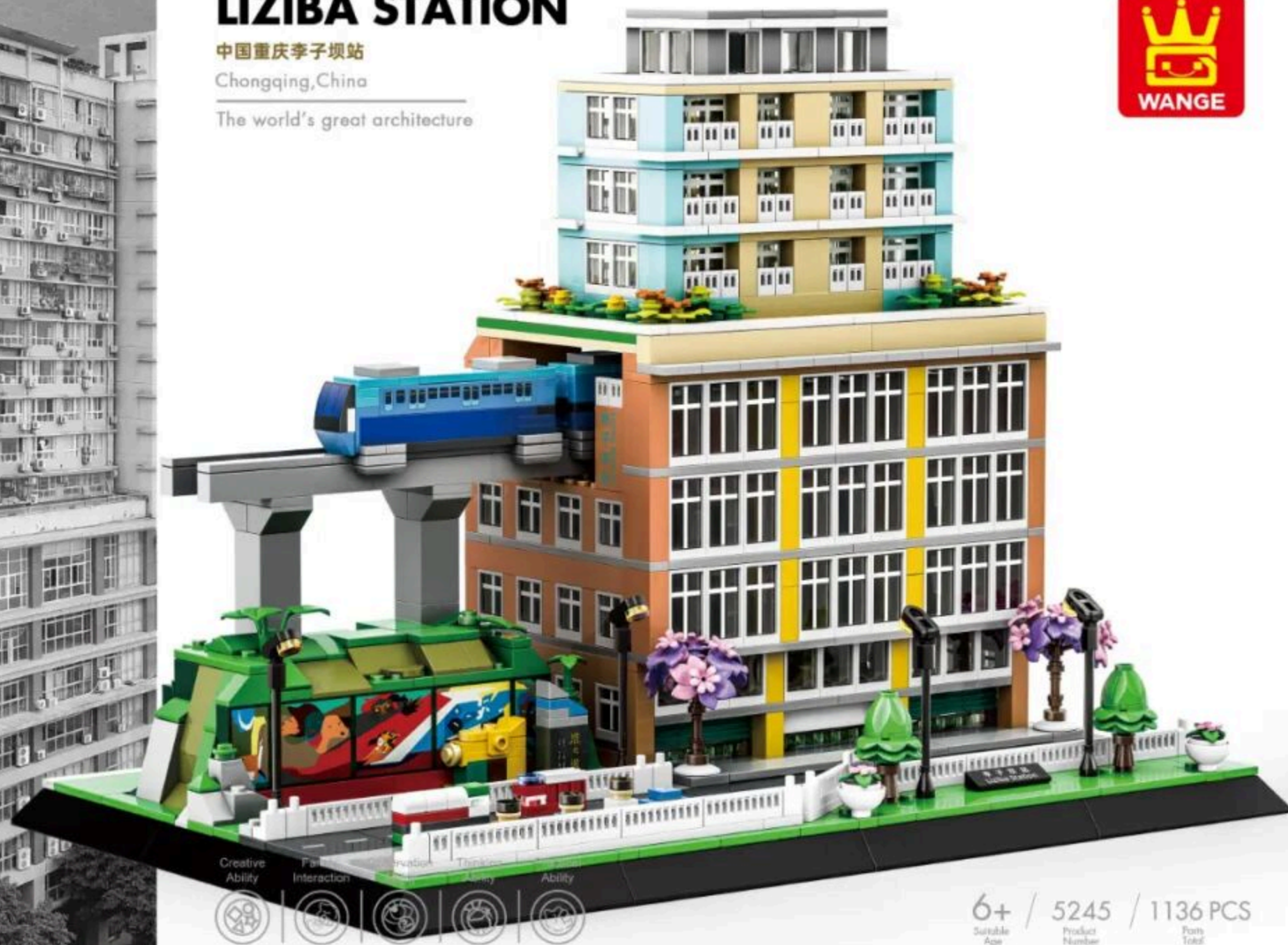

6+ / 5245 / 1136 PCS
Suitable Age / Product Number / Parts Total



Architecture

It will be a city...

这将构成一座城市...

ABOUT THE PRODUCT

关于产品

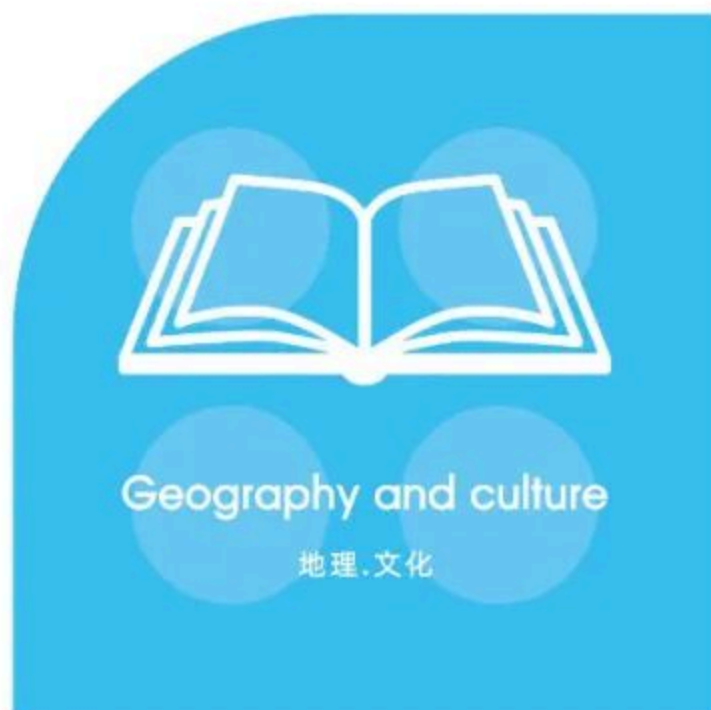

ARCHITECTURE

WANGE The world's great architect since 1991

Liziba Station

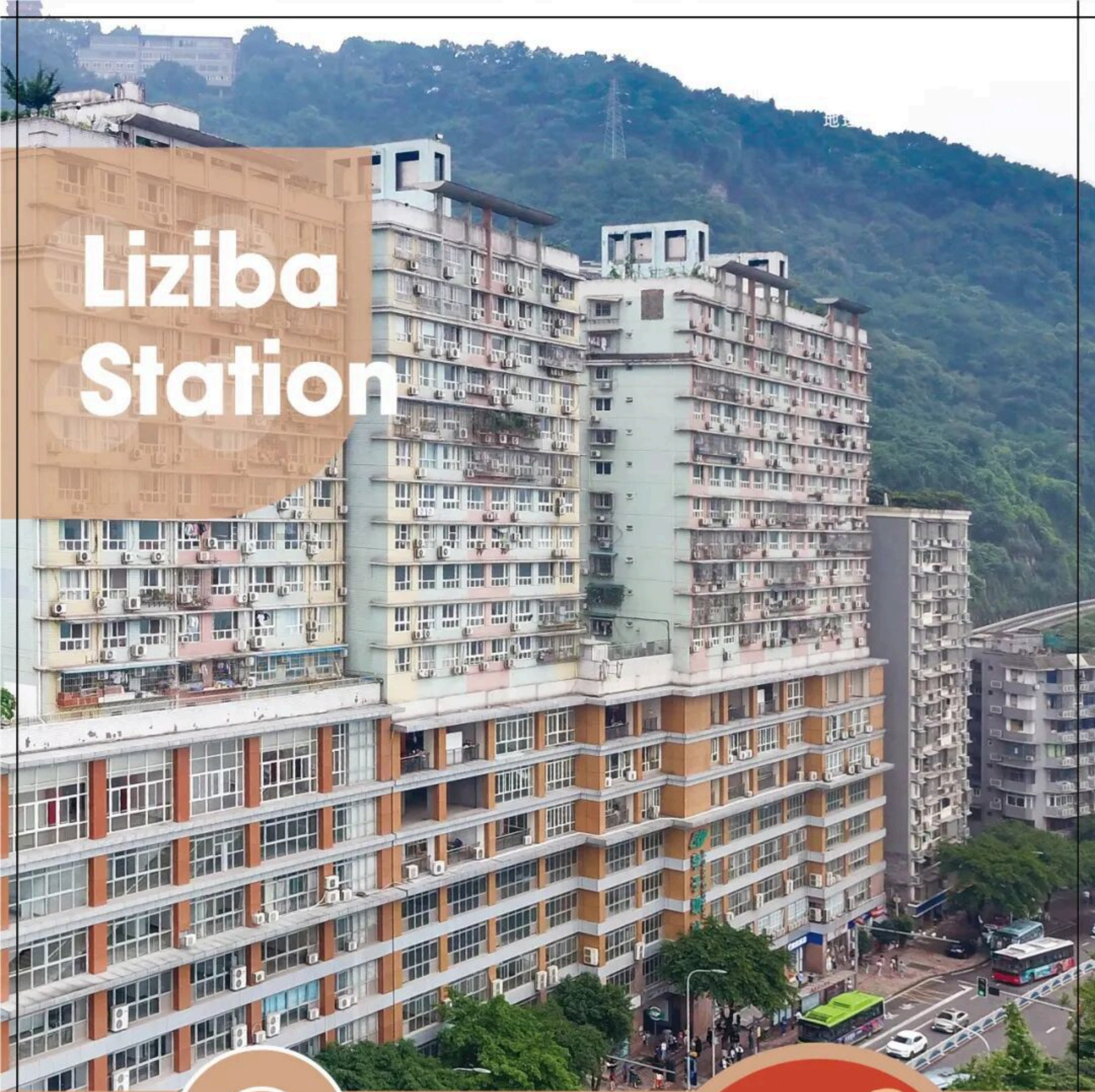

Liziba Station, station number 207, is located at No. 39, Liziba Main Street, Yuzhong District, Chongqing. It is the first straddle-type monorail elevated station in China that coexists with commercial and residential buildings.

Liziba Station



Geography and culture

地理·文化



Liziba Station was opened for trial operation on June 18, 2005. Liziba Station is located at No. 39, Liziba Main Street, Yuzhong District, Chongqing. It is the first straddle-type monorail elevated station in China that coexists with commercial and residential buildings.



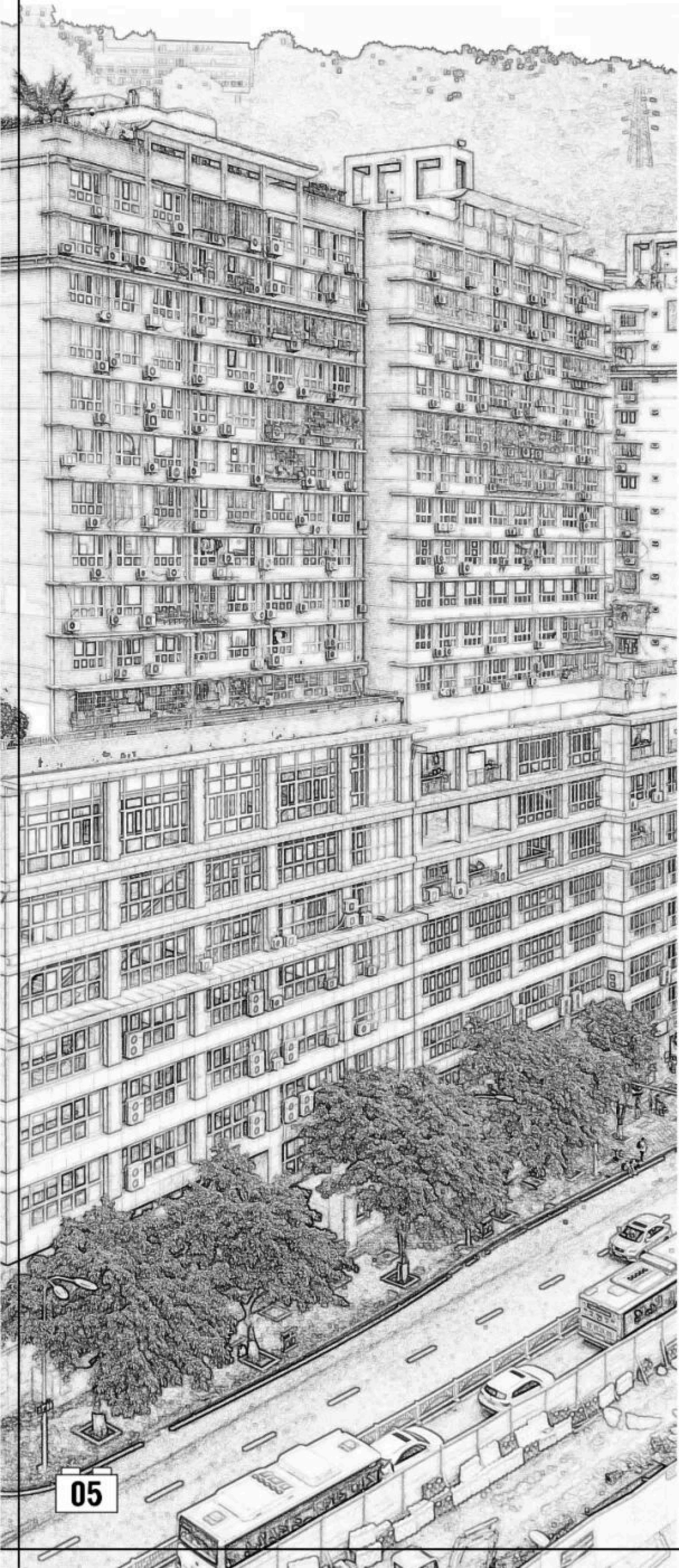

中国重庆李子坝站

Liziba ■ Station China

The contents of this chapter refer to the Wikipedia website.

本章内容参考维基百科网站，更多资讯可自行查阅。

The world's great architecture

Buildings and layout

■ 建筑物和布局



李子坝站 占地面积3100平方米，建筑面积6000平方米，每层面积约3500平方米，空高约3.6米，列车穿越的长度有132米。车站没有借用楼房的承重结构，支撑列车轨道梁的6根桩基均有38米高，直接打桩到地面地基中，而楼栋的桩基约有90多根，每根高度69米，在6根轨道梁桩基与楼房建筑之间，有20厘米的安全距离。

Liziba Station covers an area of 3,100 square meters, with a construction area of 6,000 square meters. Each floor is about 3,500 square meters, with a ceiling height of about 3.6 meters. The length of the train crossing is 132 meters. The station does not use the load-bearing structure of the building. The six piles supporting the train track beams are 38 meters high and are directly piled into the ground foundation. There are more than 90 piles of the building, each 69 meters high. There is a 20-centimeter safety distance between the six track beam piles and the building.



Symbolism

李子坝车站综合楼项目作为重庆轨道集团实施的第一个轨道交通上盖开发物业，开创了国内轨道交通高架车站上盖物业开发的先河。通过车站与商住楼同步设计、同步建设、同步投用，不仅节约了轨道交通结构工程费用约3000多万元，合理利用地形高差解决了桂花园路和李子坝正街的衔接，方便了区域市民；而且利用车站上部空间提供了约400户居民住房，较好地实现了低资源消耗、城市有限空间利用效益的最大化。

The Liziba Station Complex Project pioneered the development of property above elevated rail transit stations in China. Through the simultaneous design, construction and commissioning of the station and the commercial and residential building, the connection between Guihuayuan Road and Liziba Main Street was solved by making rational use of the terrain height difference, which facilitated the residents in the area; the upper space of the station was used to provide housing for about 400 households, which better achieved low resource consumption and maximized the benefits of limited urban space.

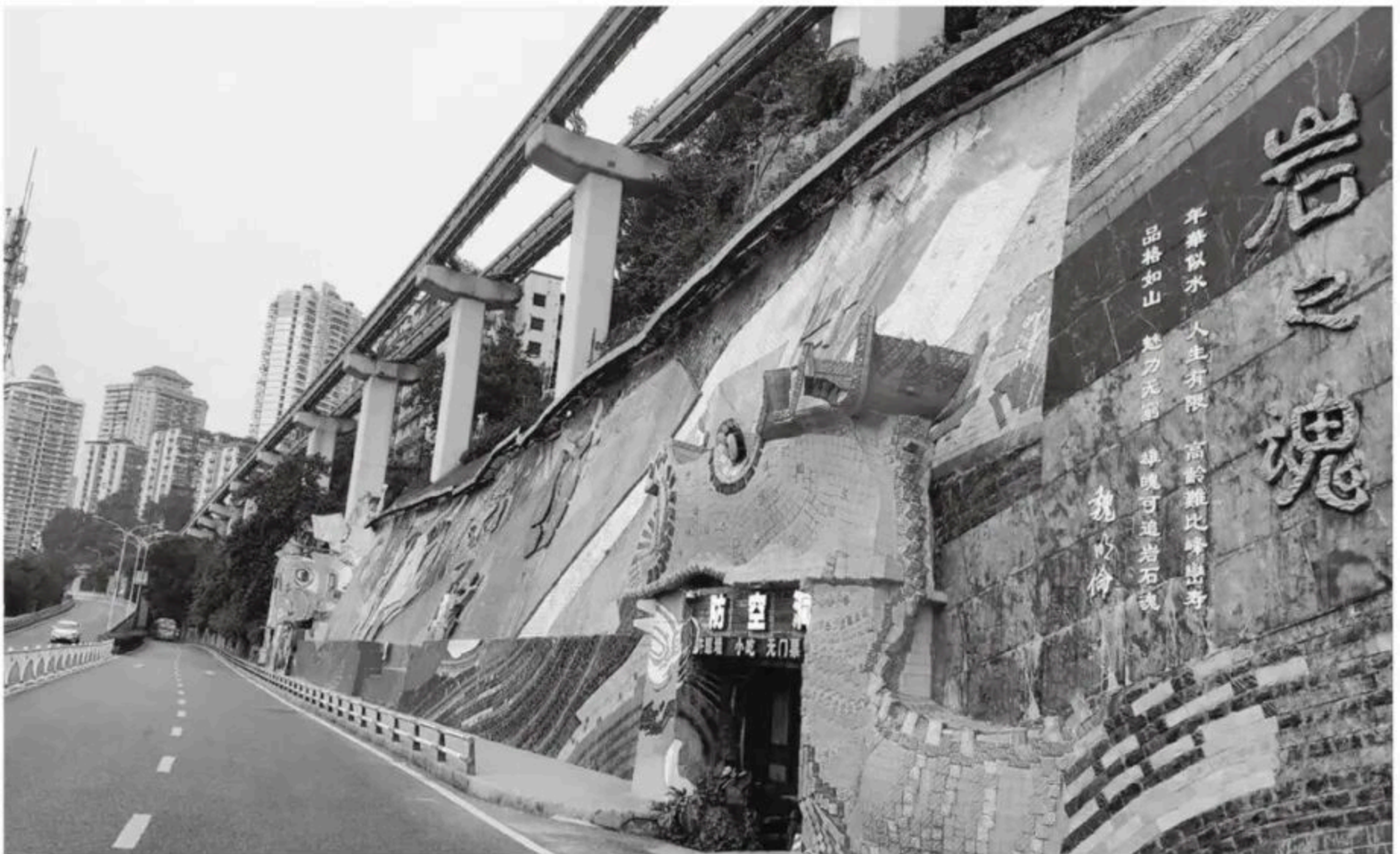

Design and construction

李子坝站于2000年开工建设；于2004年3月建成；于2004年12月11日开始观光运行；于2005年6月18日开通试运营。李子坝站体共分三层，上层为站台层，下层为站厅层，中间层为设备层，站点共有1、2两个出入口：1出入口位于建筑一层，李子坝正街南侧，通过六层电动扶梯及楼梯与6楼的站厅层相连；2出入口位于整栋建筑的8楼，与站台层同层，位于桂花园路北侧。1出入口附近设有公交站（轨道李子坝站），方便出站人群换乘；2出入口由于地形限制，便于站点周边的居民可以快捷地到达车站。由于站点的1、2出入口分别在整栋建筑的两侧，当通过该两个出口分别进入站体内部后，会分别位于轨道的两侧，如果乘坐反方向的列车，需要下到站厅层换行至轨道对面站台。

Liziba Station was put into trial operation on June 18, 2005. Liziba Station is divided into three floors, the upper floor is the platform floor, the lower floor is the station hall floor, and the middle floor is the equipment floor. The station has two entrances and exits: Entrance 1 is located on the first floor of the building, on the south side of Liziba Main Street, and is connected to the station hall on the 6th floor through a six-story escalator and stairs; Entrance 2 is located on the 8th floor of the entire building, on the same floor as the platform floor, and is located on the north side of Guihuayuan Road. There is a bus stop near Entrance 1 to facilitate the transfer of people leaving the station; Entrance 2 is restricted by the terrain, so that residents around the station can quickly reach the station.

Force Balance

受力平衡

Physical operations

物理运算

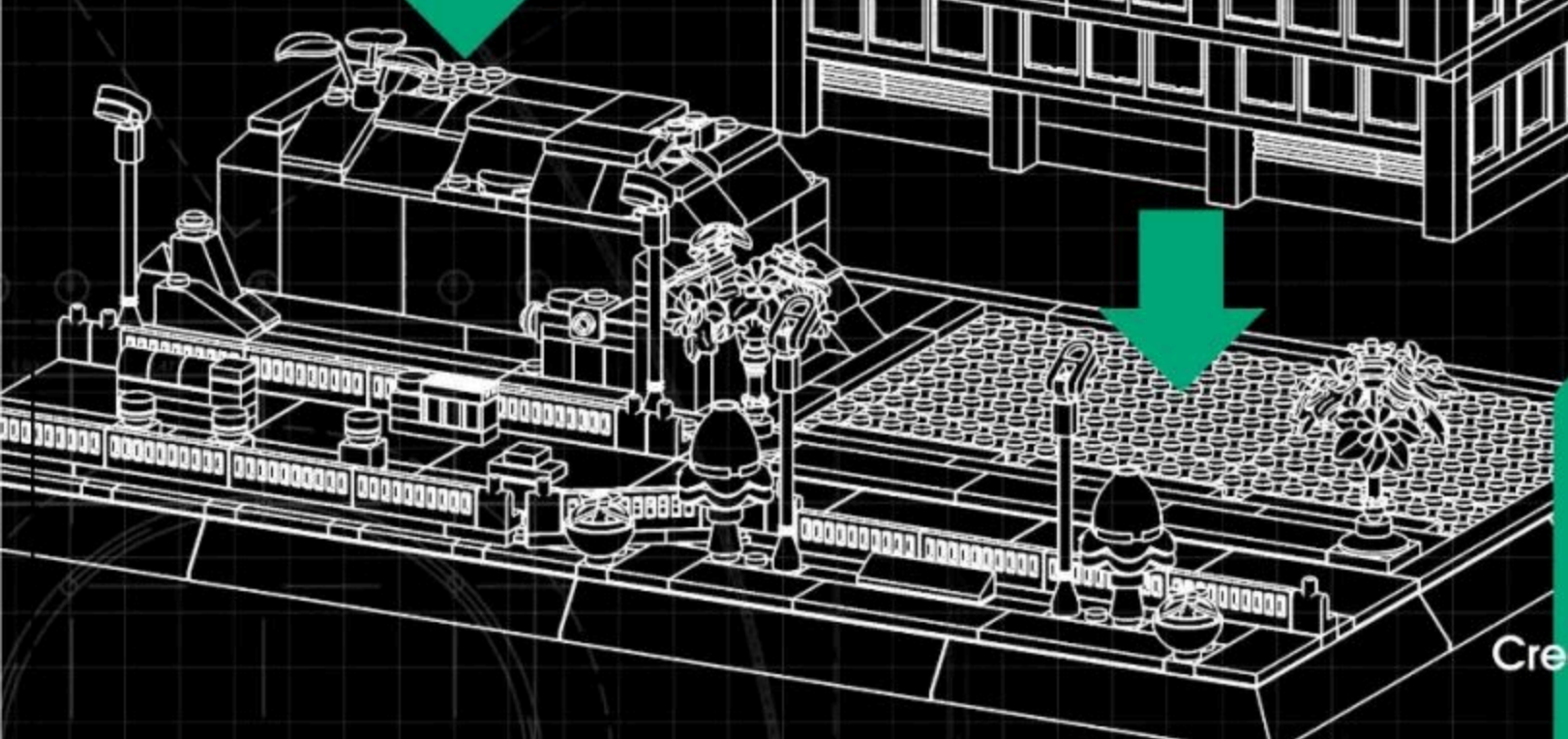
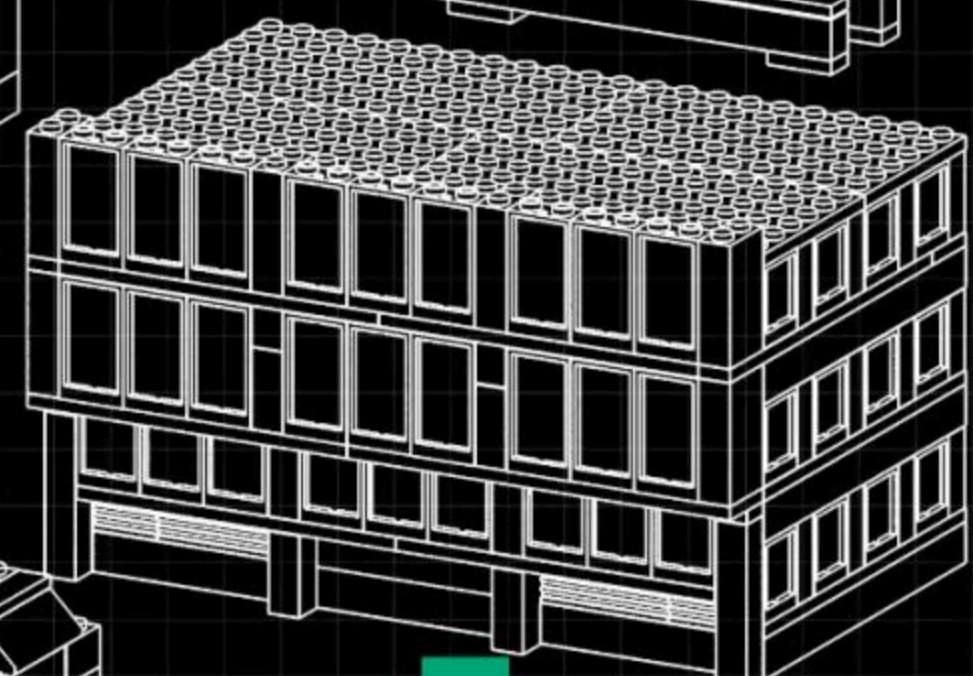
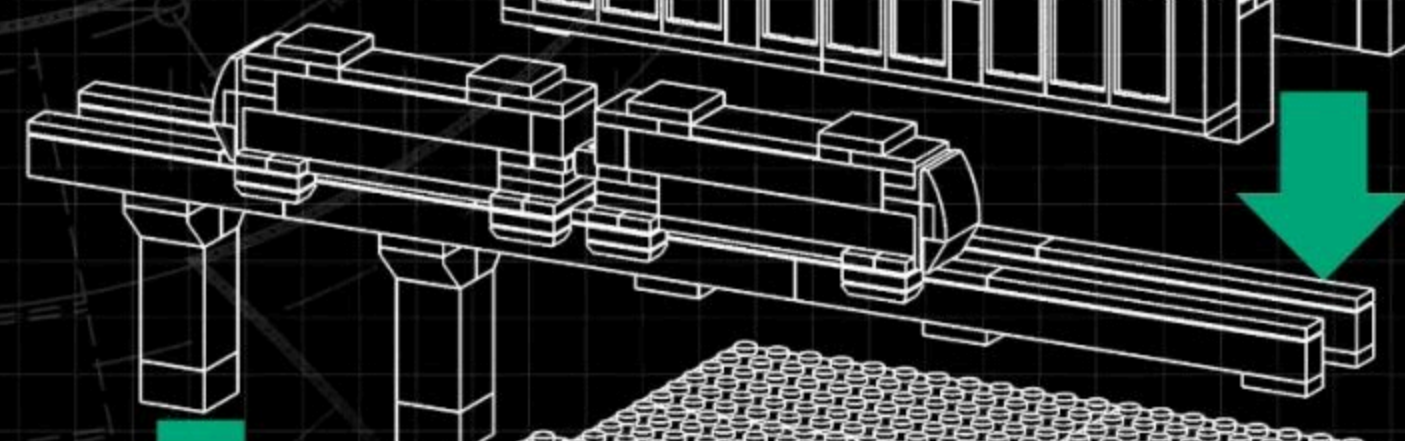
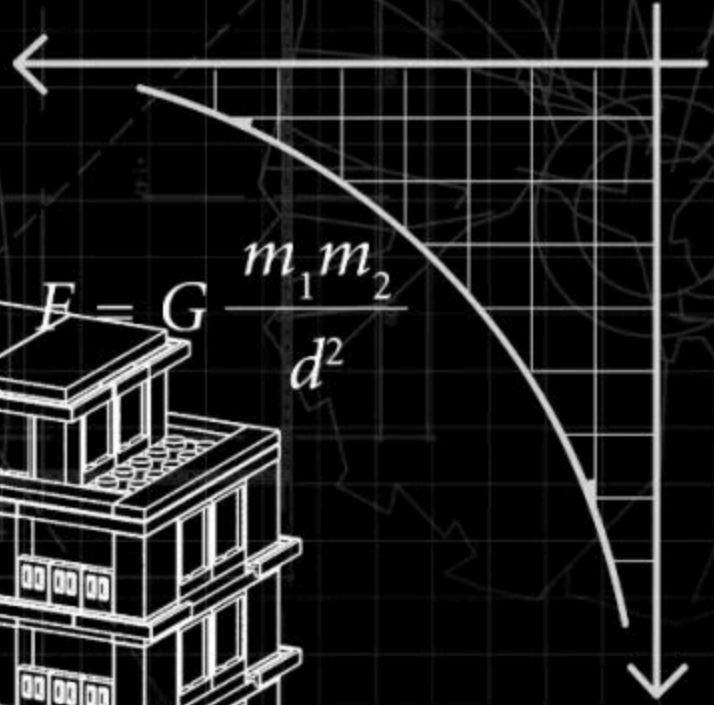

Creation and thinking

创作·思考

$$S=4\pi \cdot r^2$$

Special parts

特殊零件的开发利用

$$a^2+b^2=c^2$$



WG1274

1孔栏杆



WG1411

六瓣花4孔



WG1250

无孔2分圆



WG1506

1孔拱形栏杆



WG1345

竖纹2倍2孔

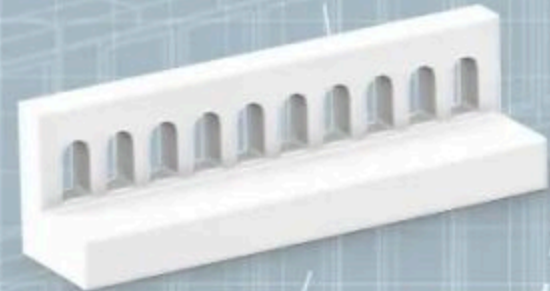

WG1342

4孔拱形栏杆



WG1026

竹子



WG1508

带槽直角矮3孔



WG1267

四倍窗

$$\sin^2 a + \cos^2 a = 1$$



features and functions

特点.功能

Main Color Matching

配色方案

						
Pantone 2704C	Pantone 7620C	Pantone 189C	Pantone 472C	Pantone 1575C	Pantone 123C	Pantone 7500C
						
Pantone Black 6C	Pantone 431C	Pantone Cool Gray 6C	White	Pantone 285C	Pantone 284C	Pantone 278C
						
Pantone 477C	Pantone 3435C	Pantone 383C	Pantone 2300C	Pantone 2422C	Pantone 7717C	Pantone 291C



Color matching

Adopting 3 main colors, dark meat color, light grey and beige as the main color, the more reasonable and bold color matching on the original building, making the product more atmospheric and the whole design is more reasonable.

Liziba Station

中国重庆李子坝站



Front

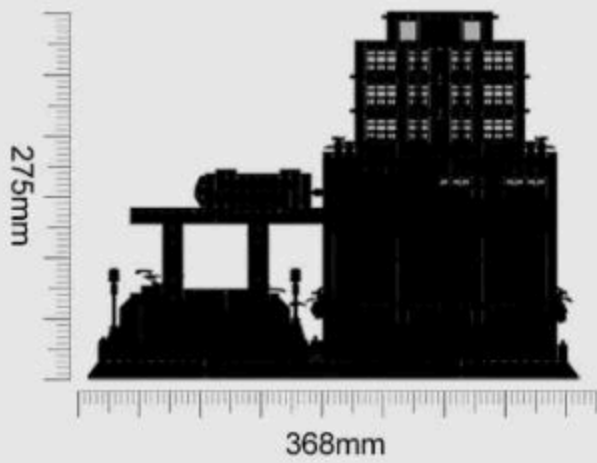

Left

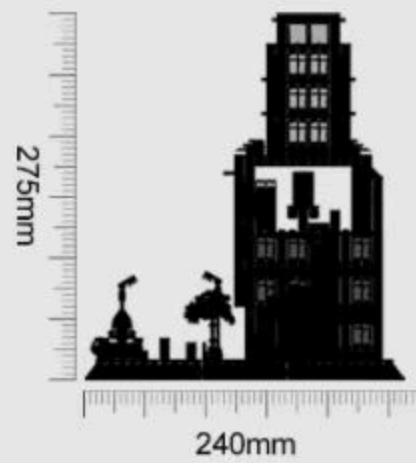

Back

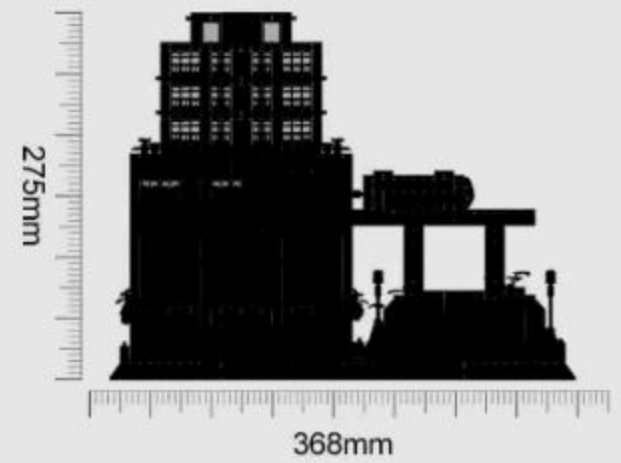

Product Size: 368X240X275mm





■ First open the product packaging according to the instructions.

按指导用正确方式拆解产品外包装。



■ Summarize all parts to count the number of familiar accessories.

对照说明书清单确认积木包数量与积木数量。



■ Arranging all accessories by color helps to quickly install the product.

把确认好的积木以类型、颜色进行分类排好以便安装。



■ Carefully install the product and learn about building.

按说明书步骤拼装并完成你的积木模型。



1:1 Physical Reference Table

十字棒配件1:1尺寸参照表



Instructions For Use

让安装更简单

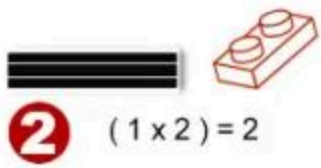

2 $(1 \times 2) = 2$

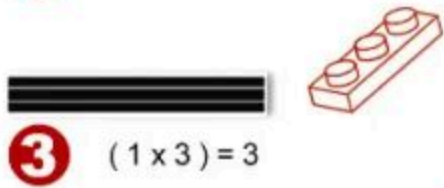

3 $(1 \times 3) = 3$

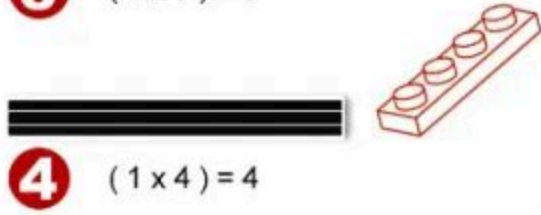

4 $(1 \times 4) = 4$



5 $(1 \times 5) = 5$



6 $(1 \times 6) = 6$



7 $(1 \times 7) = 7$



8 $(1 \times 8) = 8$



9 $(1 \times 9) = 9$



10 $(1 \times 10) = 10$



12 $(1 \times 12) = 12$



16 $(1 \times 16) = 16$



PARTS LIST

配件清单

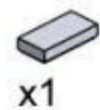
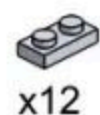
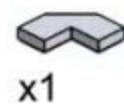
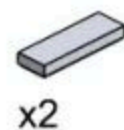
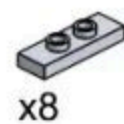
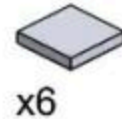
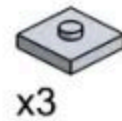
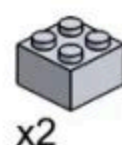
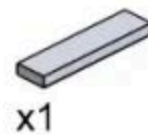
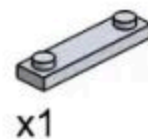
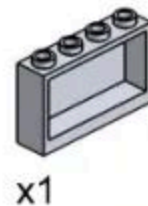
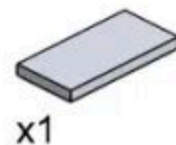
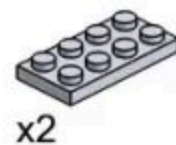
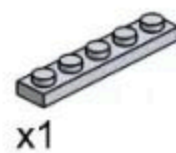
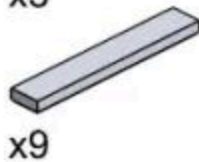
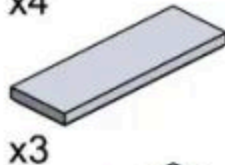
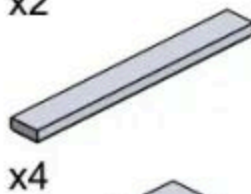
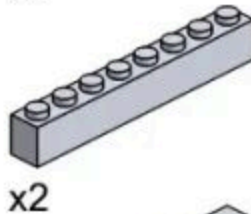
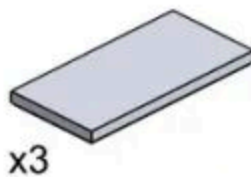
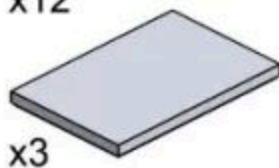
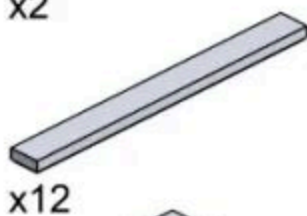
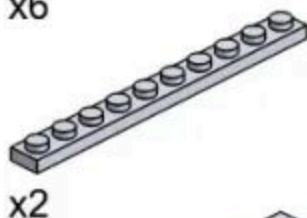
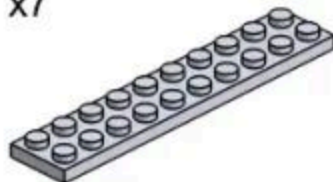
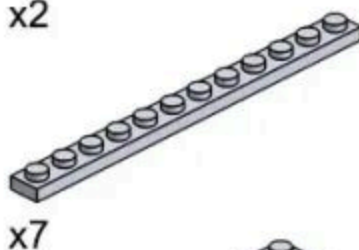
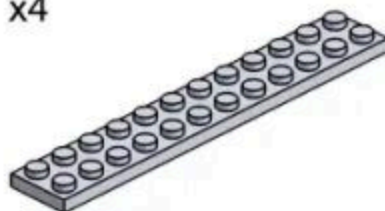
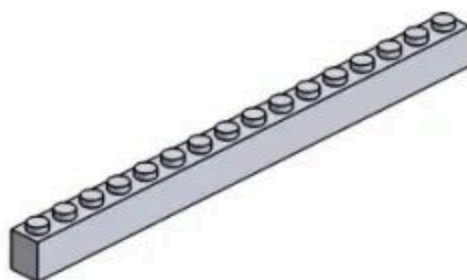
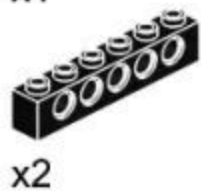
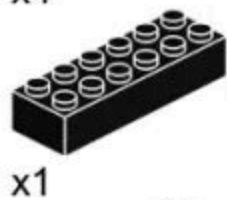
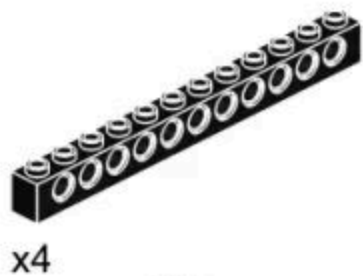
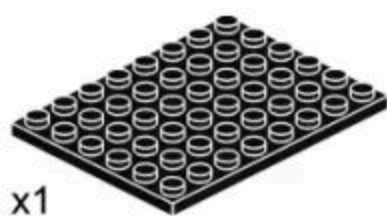
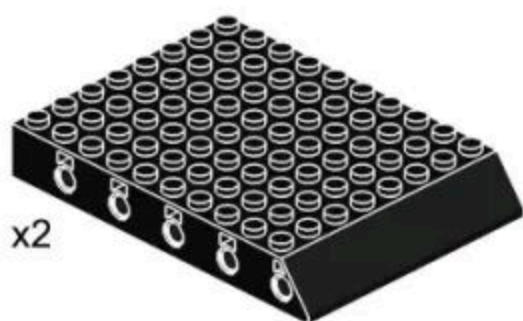
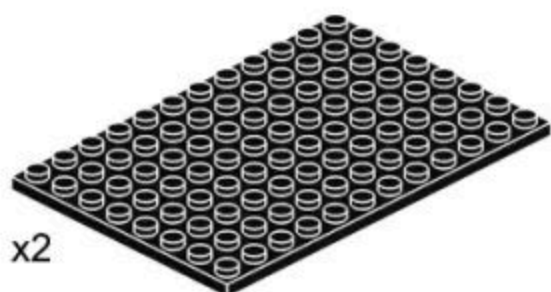
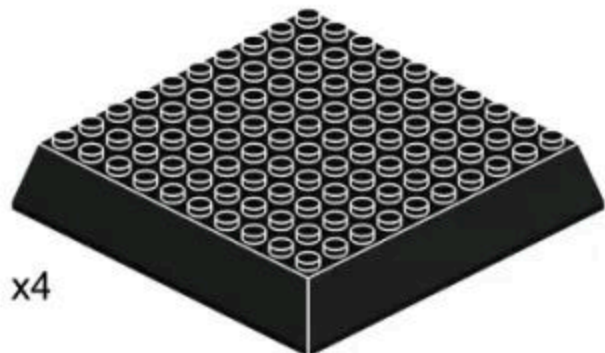

产品有增补件请以实物为准

If product has additional parts, please in kind prevail.

PARTS LIST

配件清单

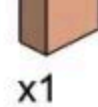
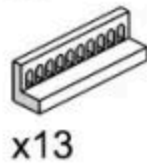
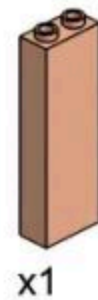
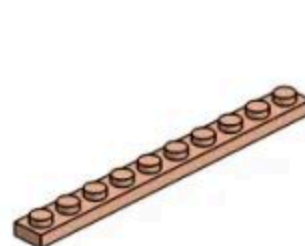
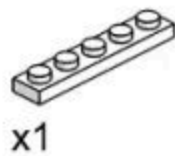
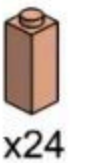
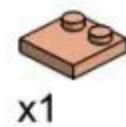
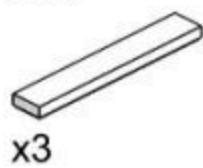
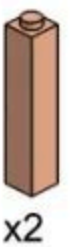
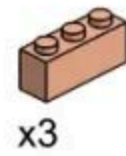
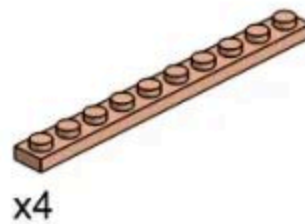
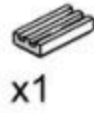
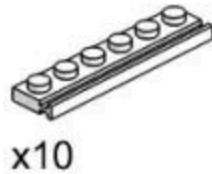
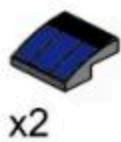
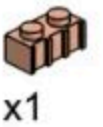
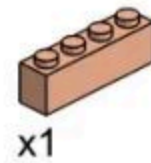
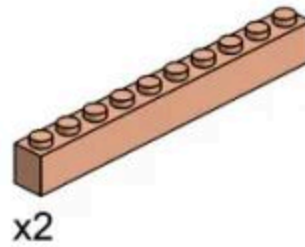
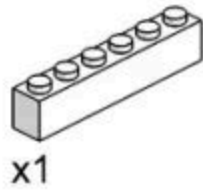
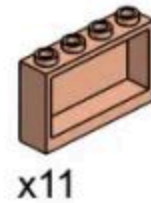
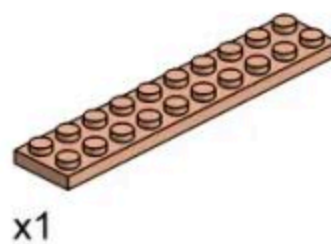
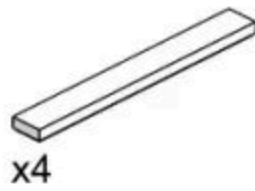
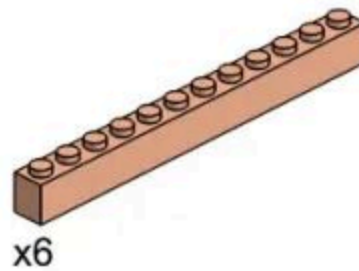
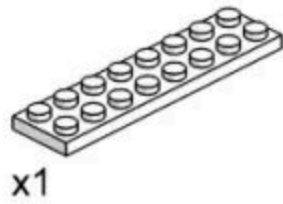
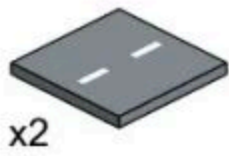
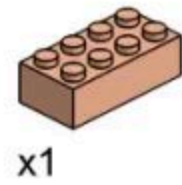
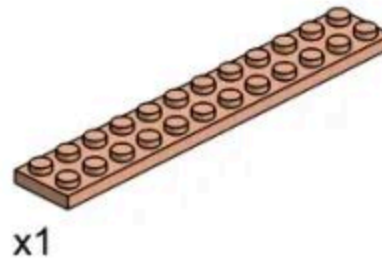
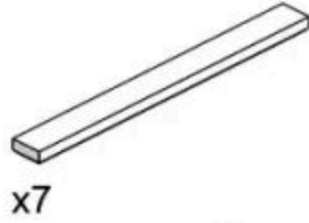
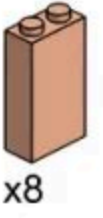
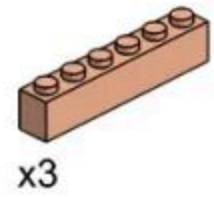
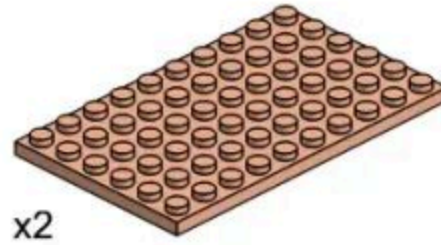
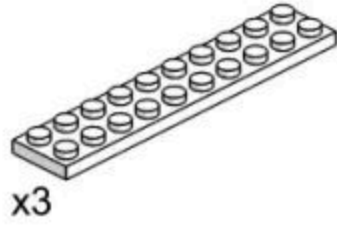
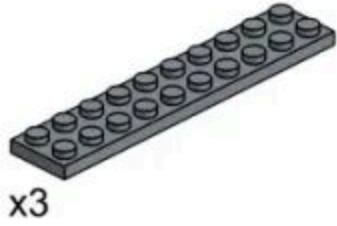
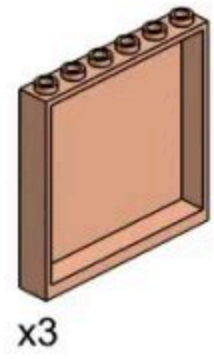
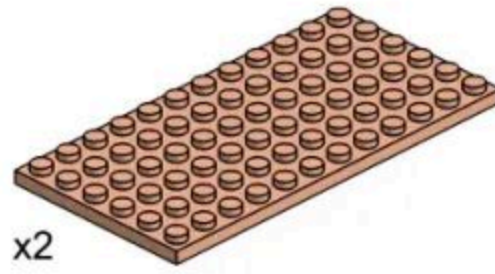
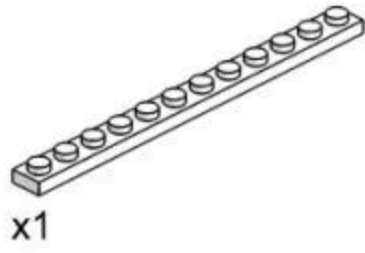
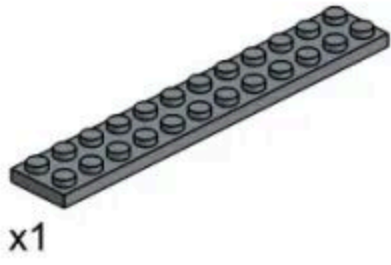

PARTS LIST

配件清单

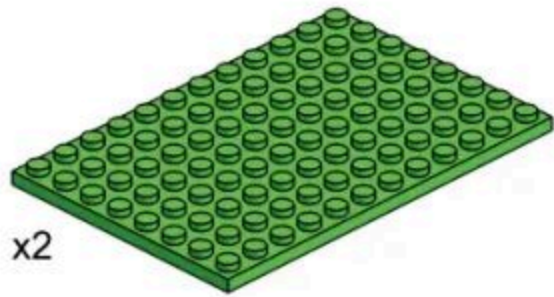

x2

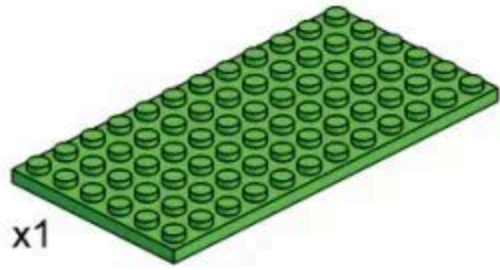

x1



x1

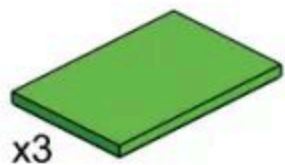

x3



x3



x1

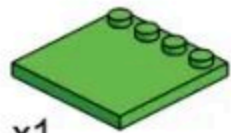

x1



x2



x7



x4

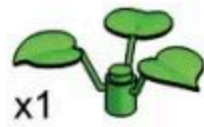

x1



x1



x1



x1

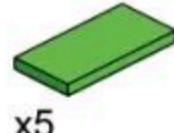

x5



x1

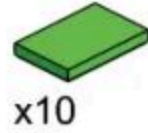

x10

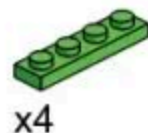

x4

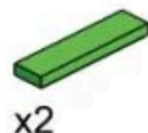

x2



x2



x1



x4

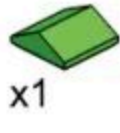

x1

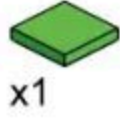

x1

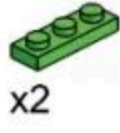

x2

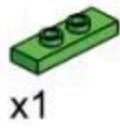

x1

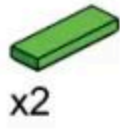

x2

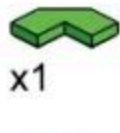

x1



x1

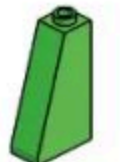

x1



x1



x1



x2

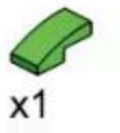

x1



x1



x2



x2



x5



x3



x2



x2



x10



x3



x1



x2



x2



x1



x13



x1



x3



x1



x1



x1



x3



x1



x2



x1



x1



x1



x1



x1



x1



x1



x1



x1

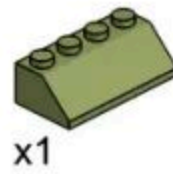

x1

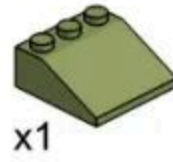

x1

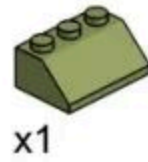

x1

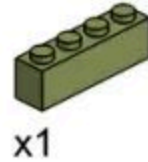

x1



x2



x2



x1

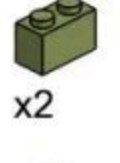

x2



x1



x9



x8



x4



x6











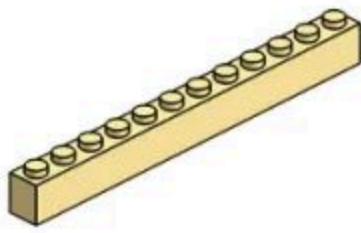
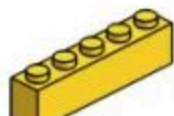

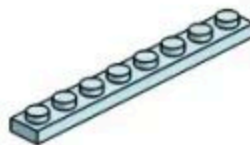
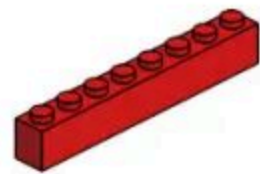
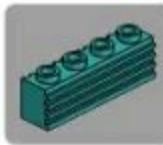

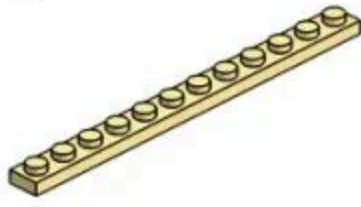

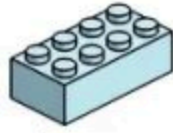



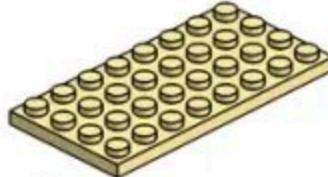

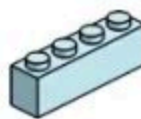



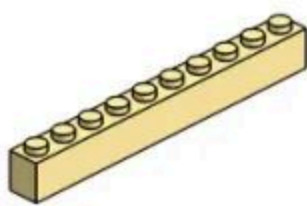

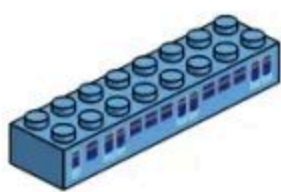
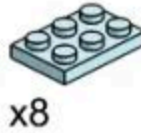



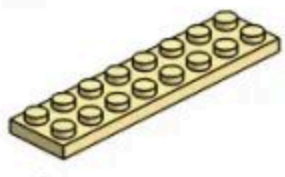

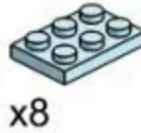

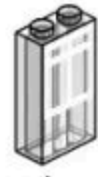
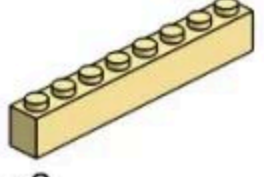

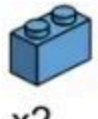







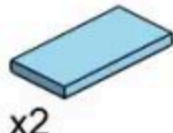





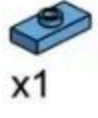





















x5

产品有增补件请以实物为准

If product has additional parts, please in kind prevail.

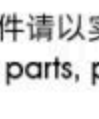
PARTS LIST

配件清单

						
x1	x2	x2	x4	x2	x2	x3
						
x2	x2	x4	x4	x2	x2	x8
						
x2	x1	x2	x2	x1	x2	x3
						
x1	x2	x2	x8	x1	x1	x12
						
x6	x4	x2	x12	x1	x1	x4
						
x2	x1	x2	x2	x4	x2	x8
						
x2	x2	x2	x2	x10	x1	x12
						
x6	x2	x2	x4	x2	x1	x9
						
x1	x1	x1	x2	x6	x1	x27
						
x12	x1	x1	x6	x10	x4	x25
						
x4	x4	x1	x1	x6	x2	x9
						
x4	x4	x1	x1	x1	x2	x4

产品有增补件请以实物为准

If product has additional parts, please in kind prevail.



253PCS

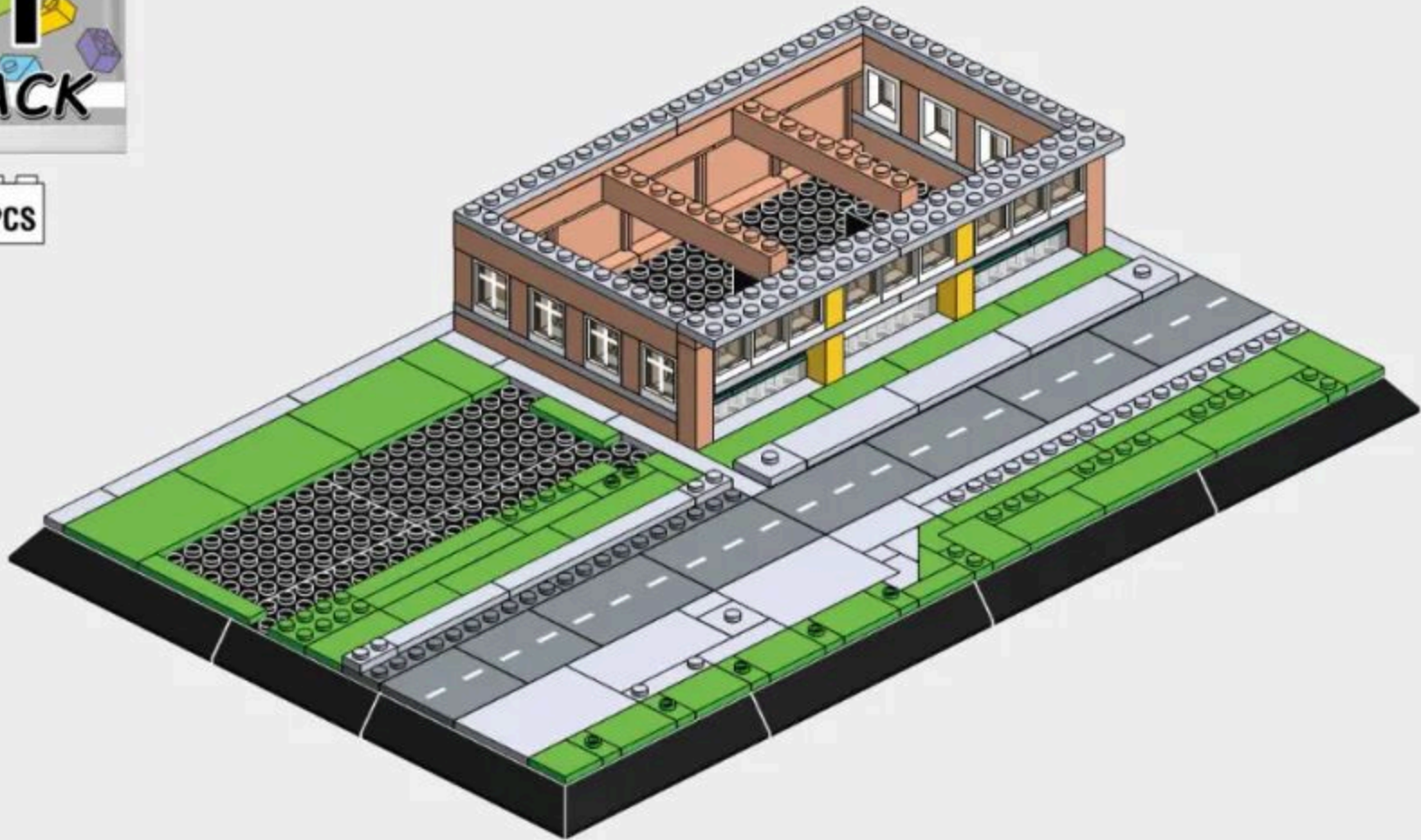

1-1



微信扫一扫
补件更简单

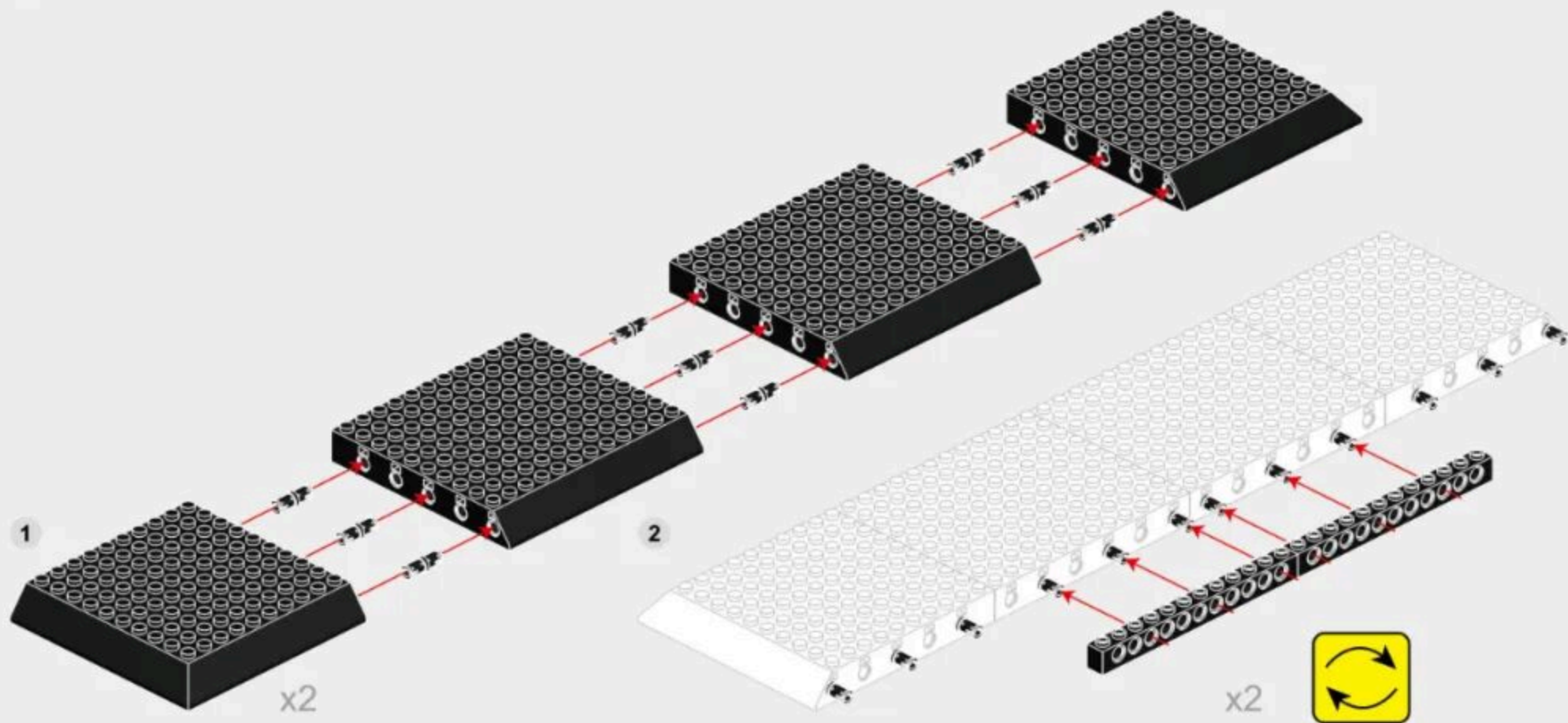
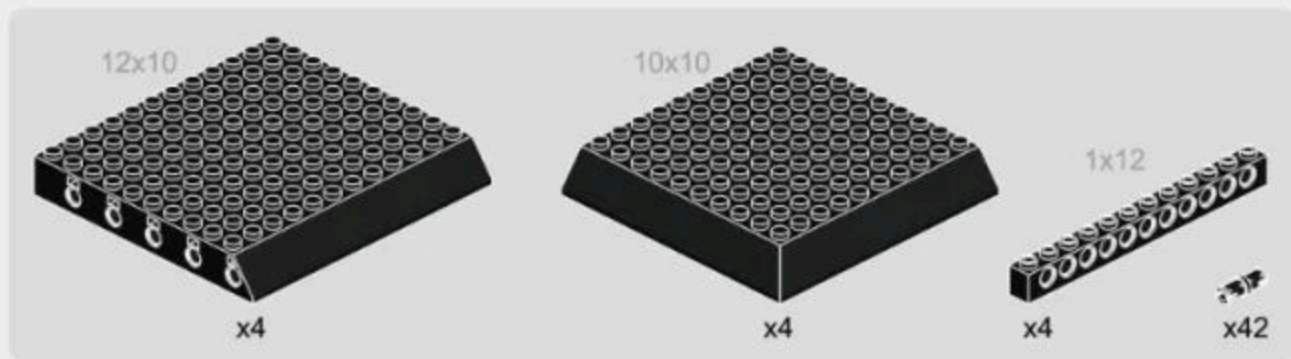

1-2

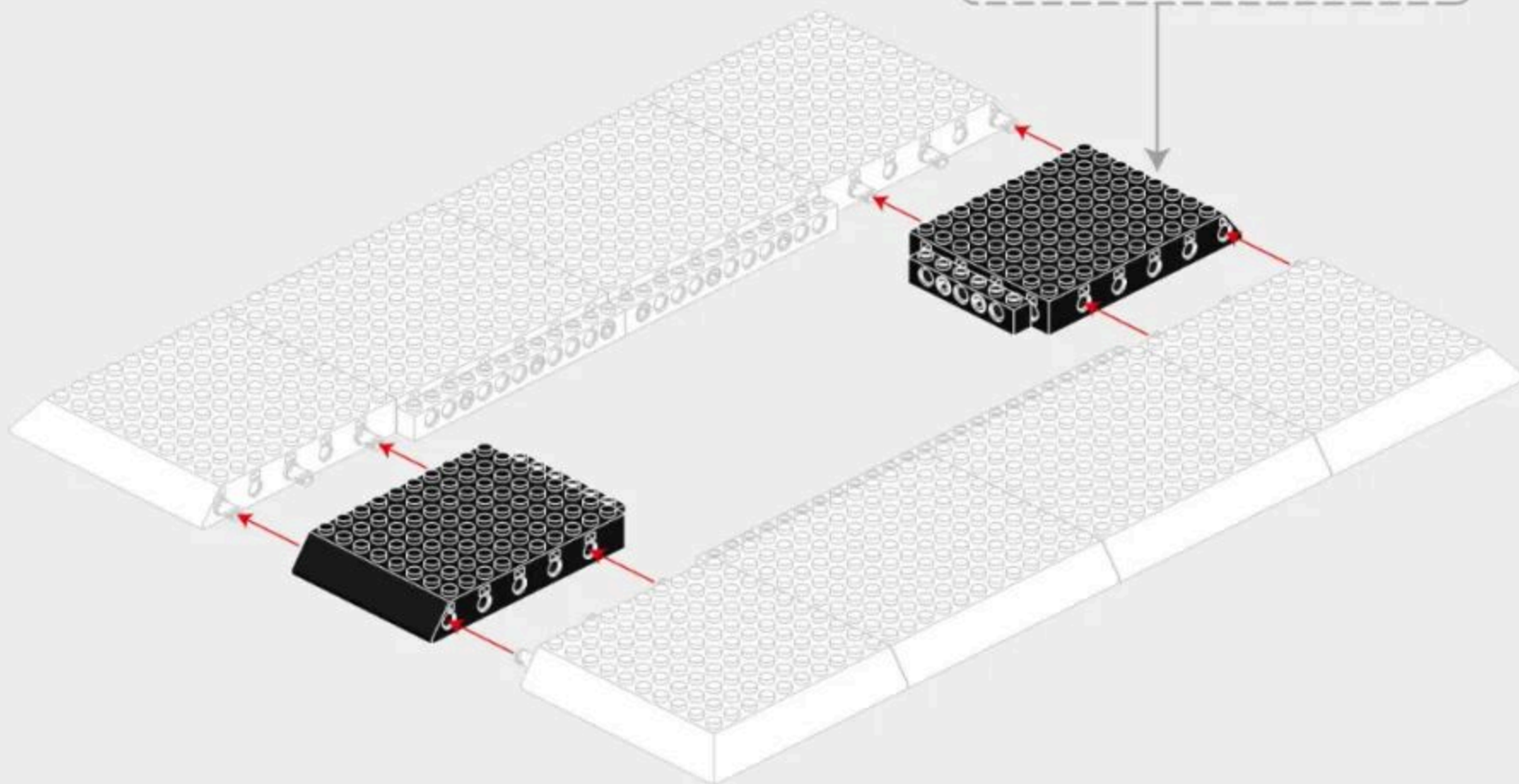
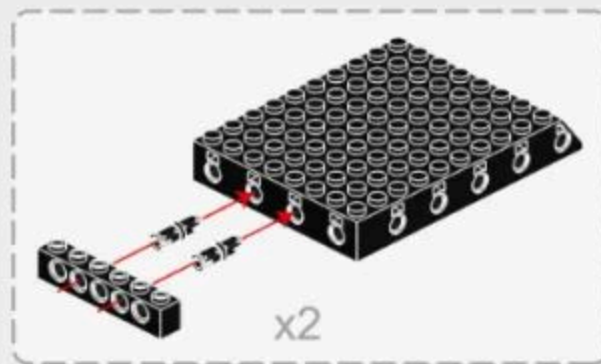
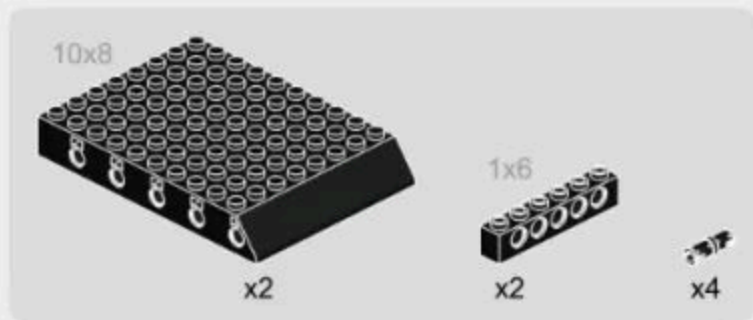

1-3

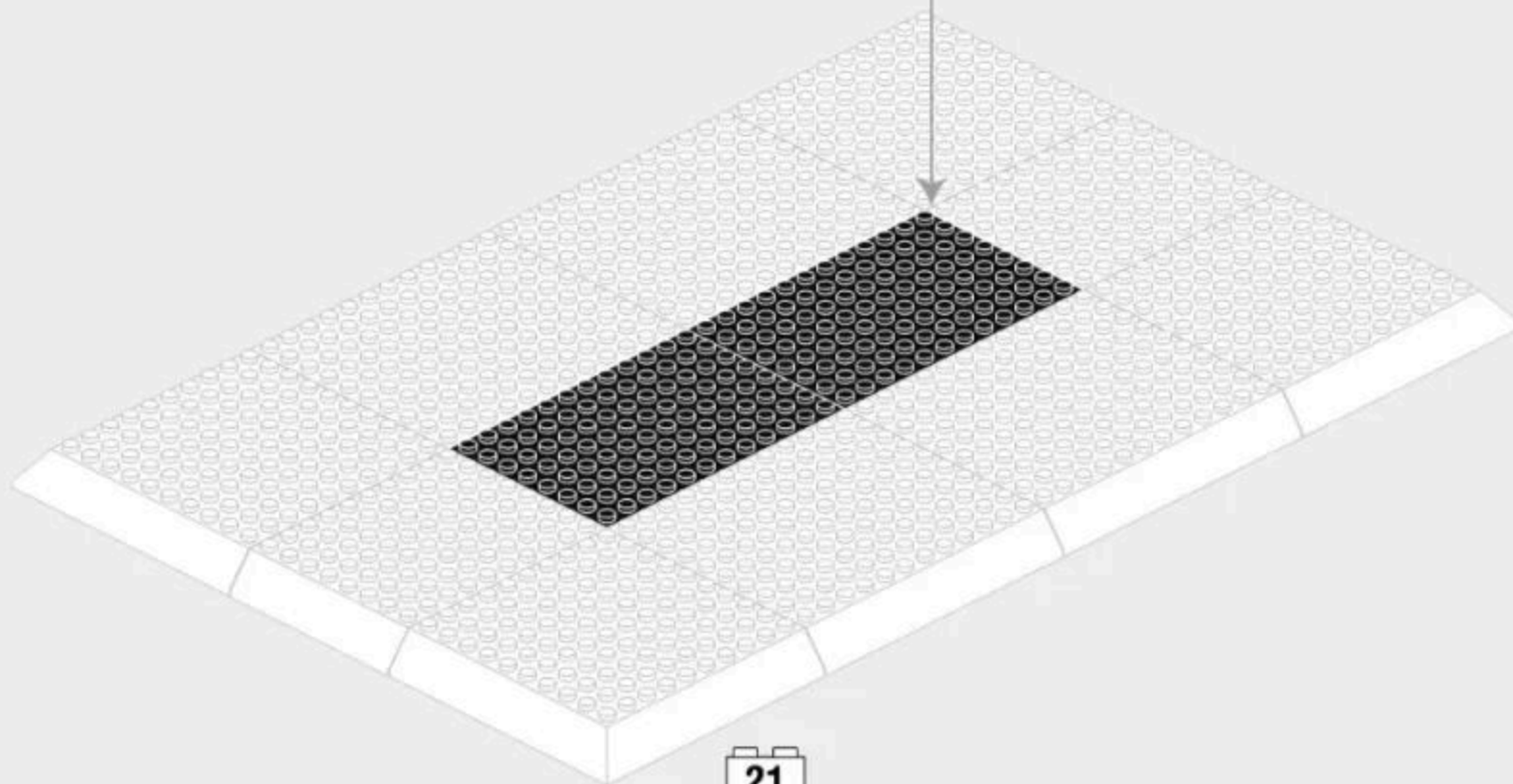
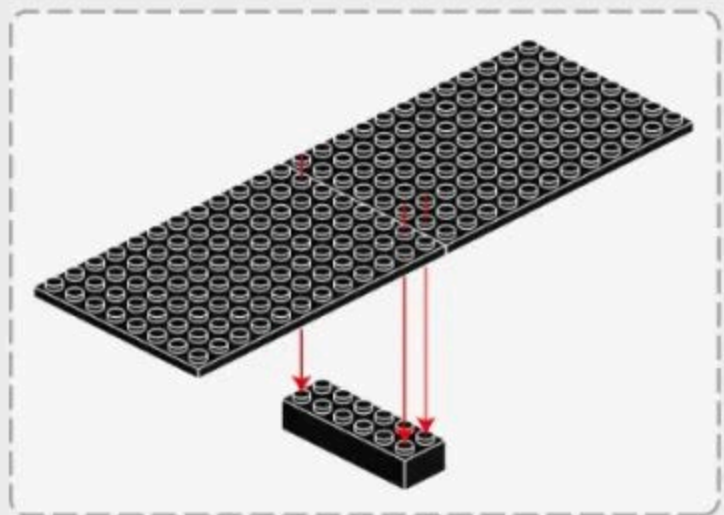
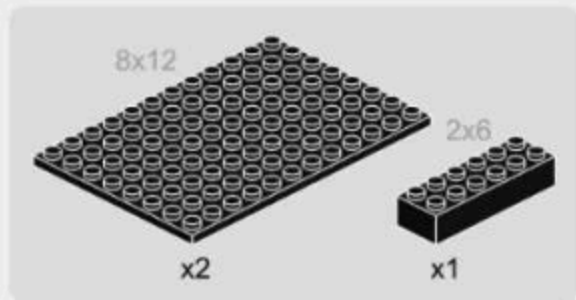

1-4

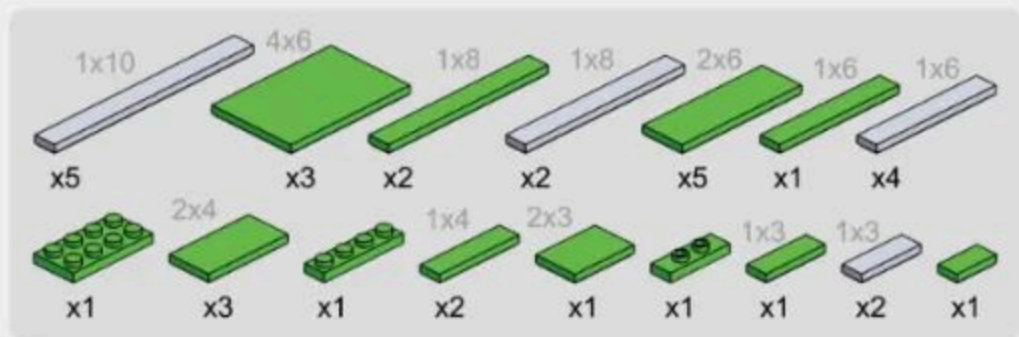

Vertical View of Installation Drawing

安装图顶面



1-5

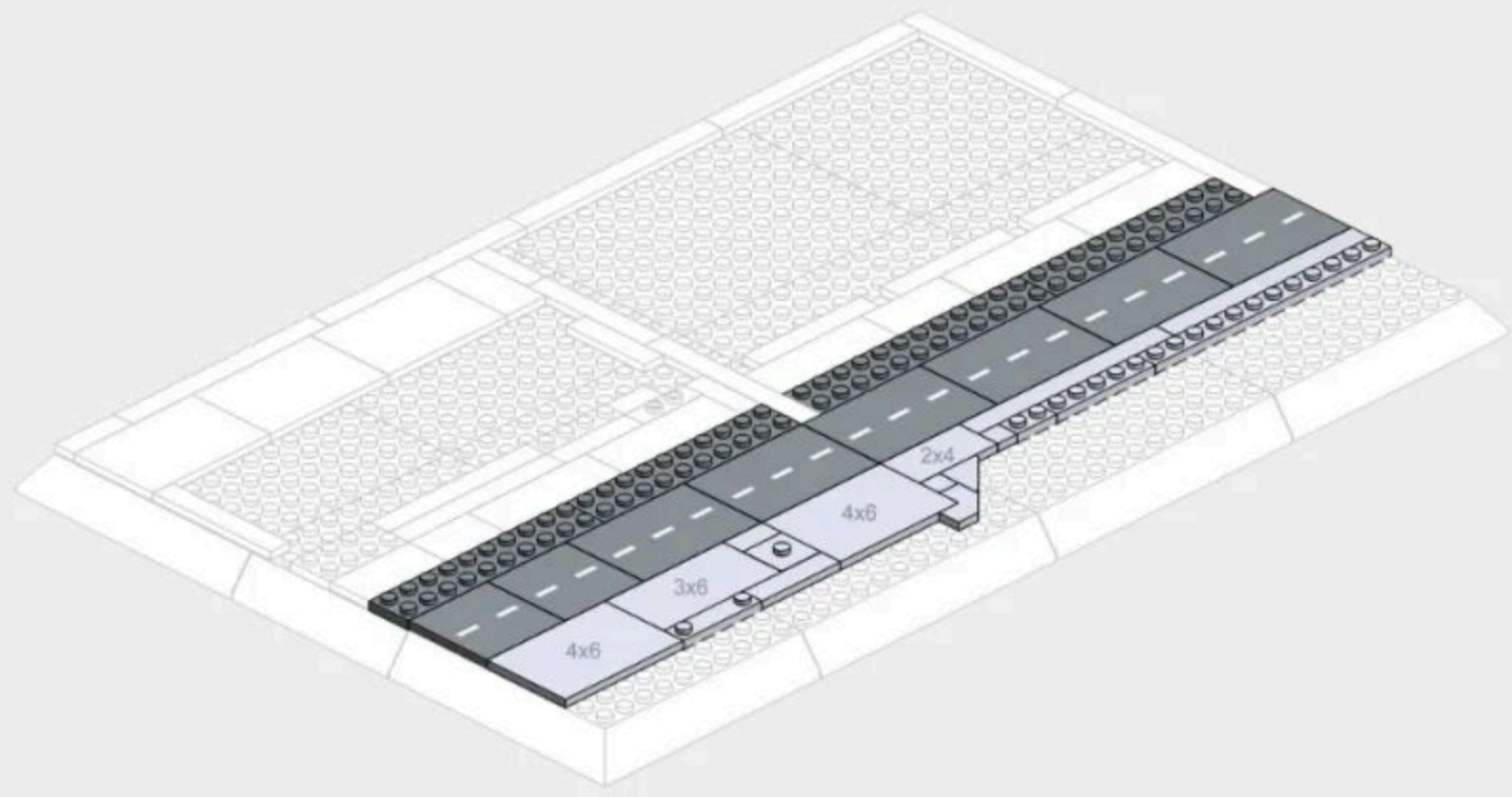
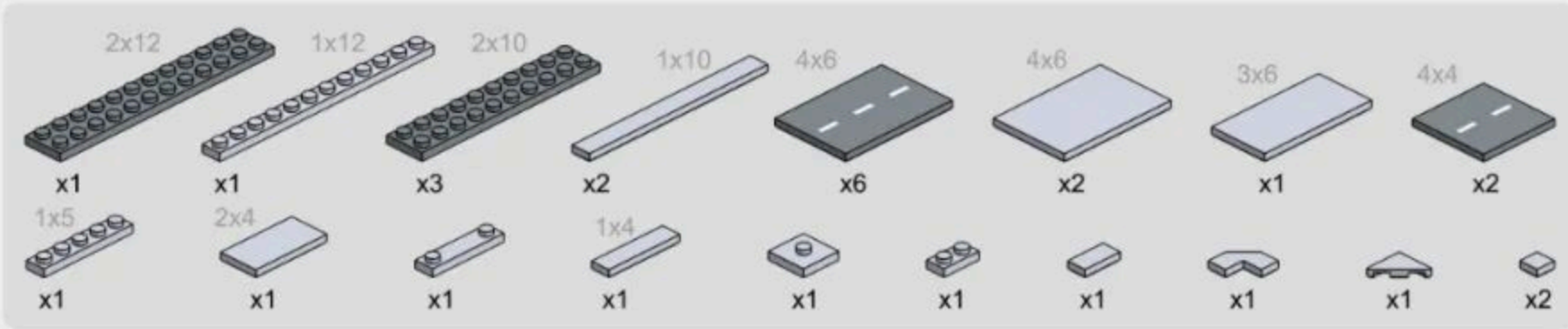

1-6

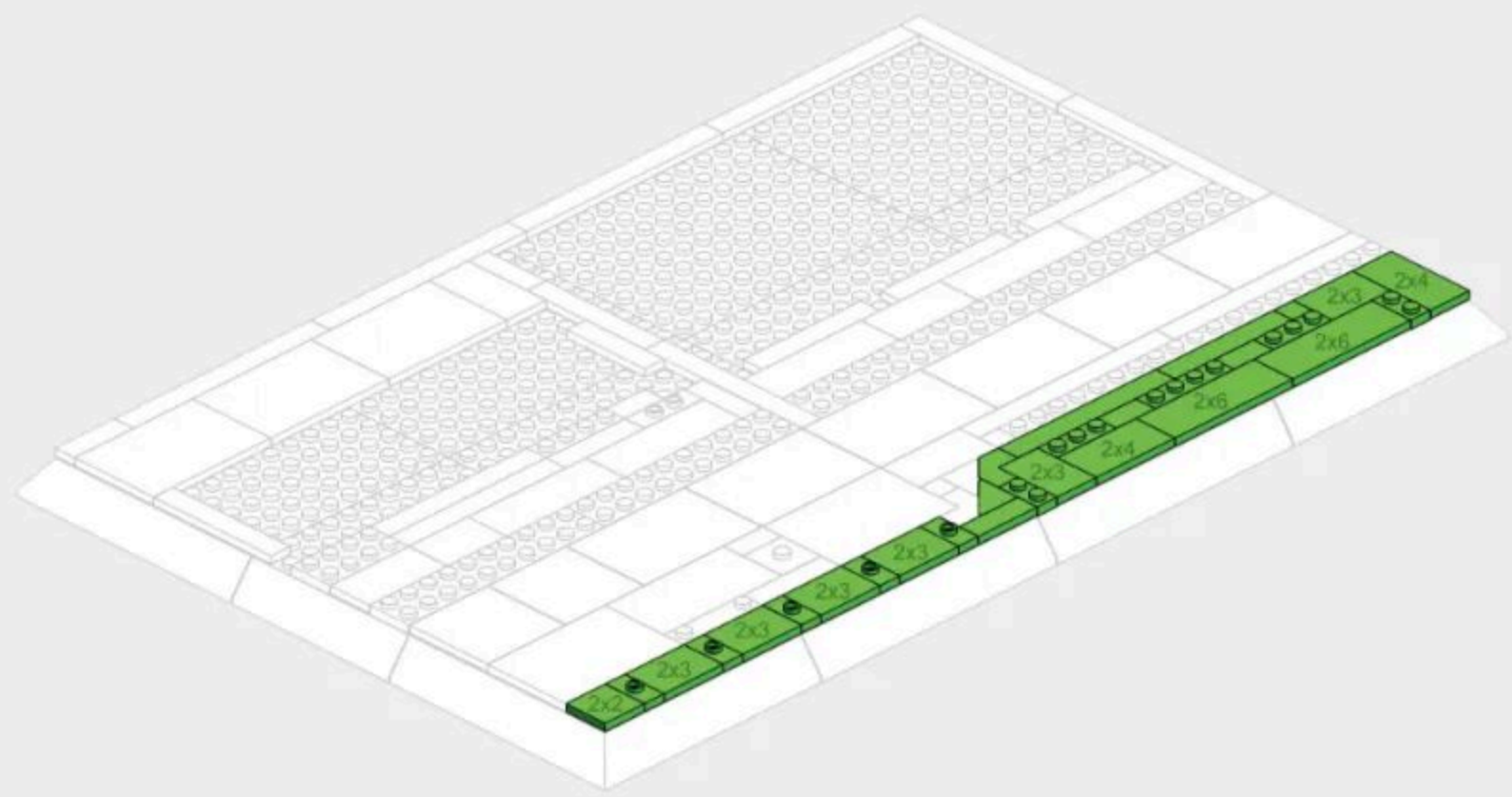

1-7

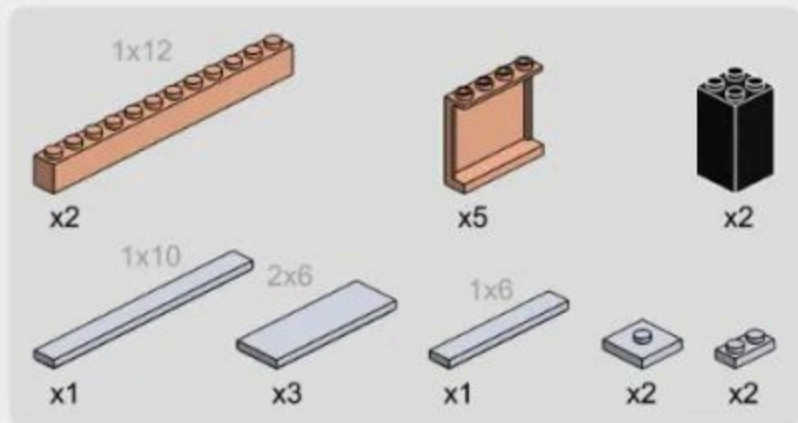

Vertical View of Installation Drawing
安装图顶面

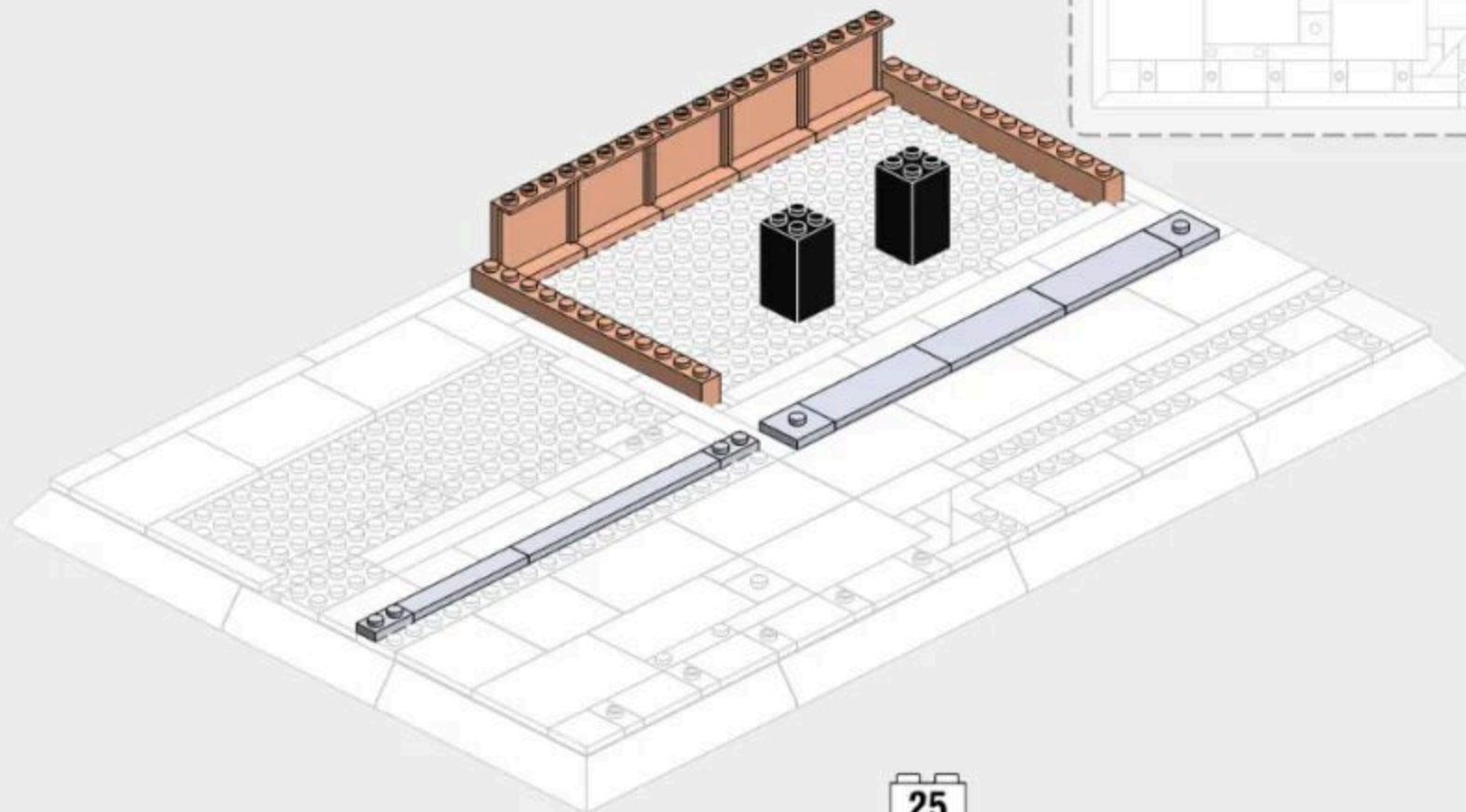
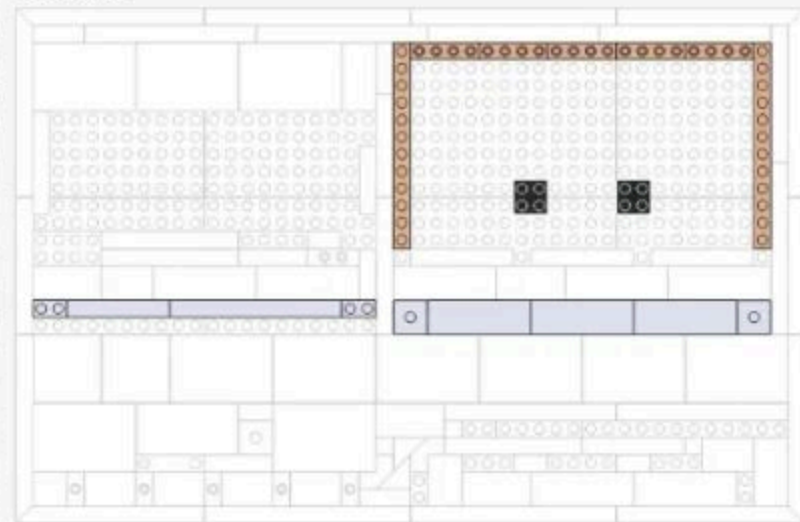

1-8

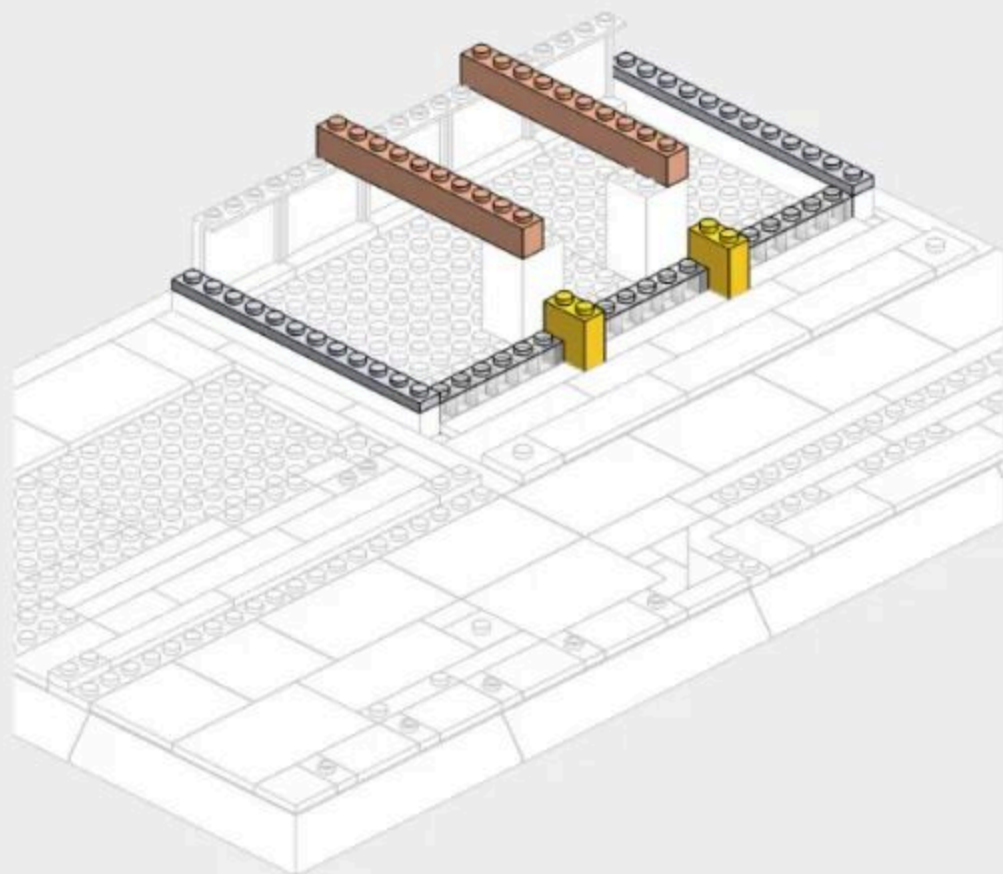
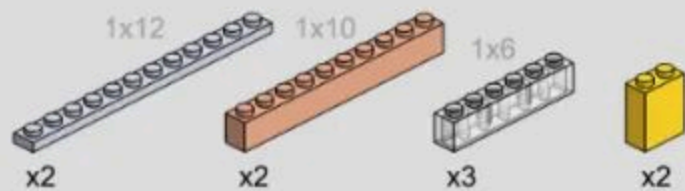

1-9

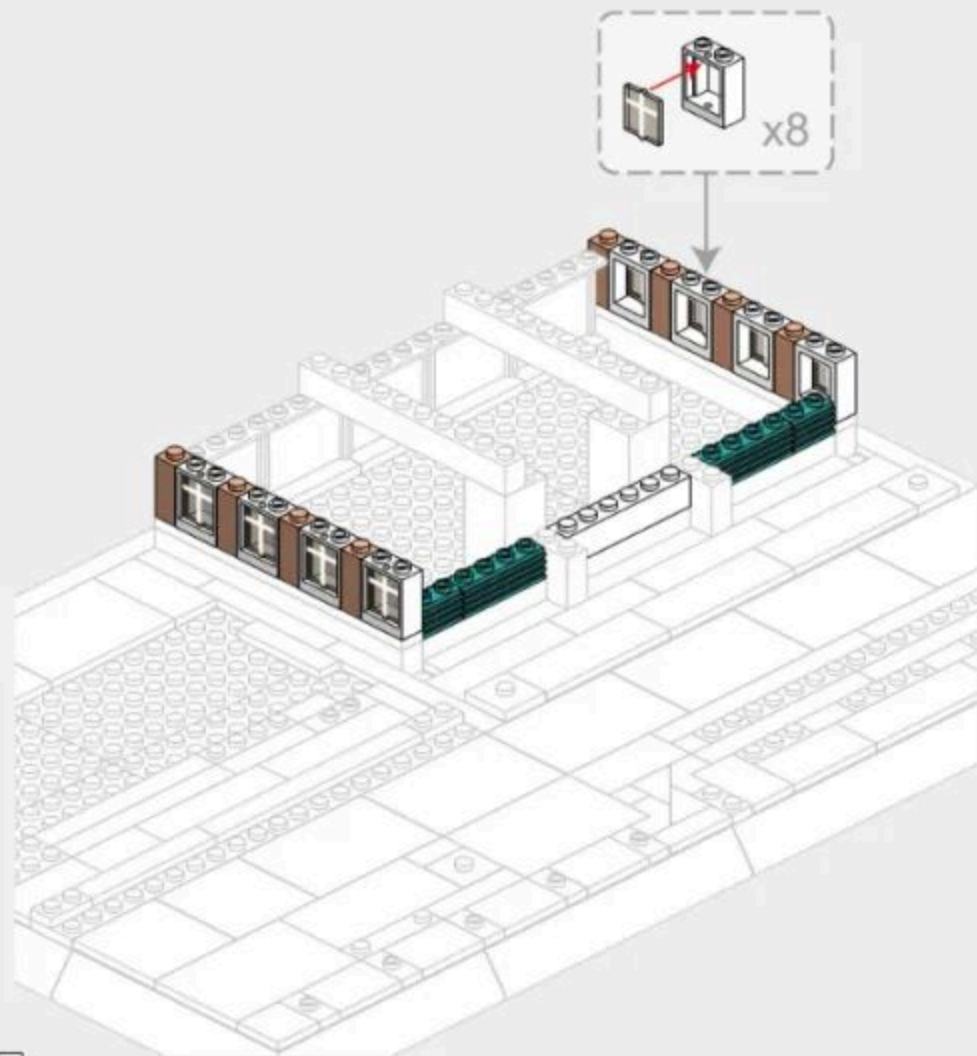

1-10

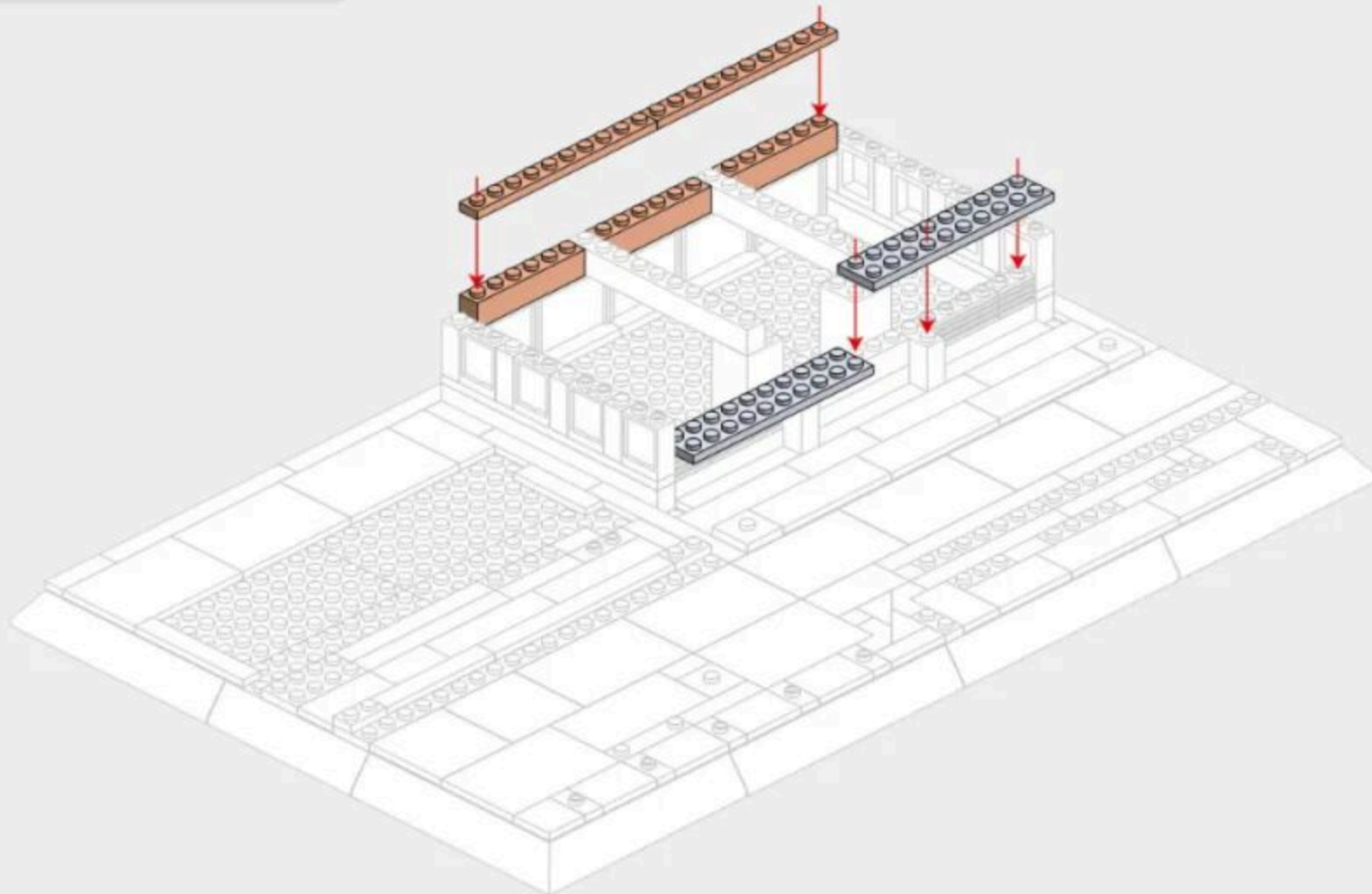
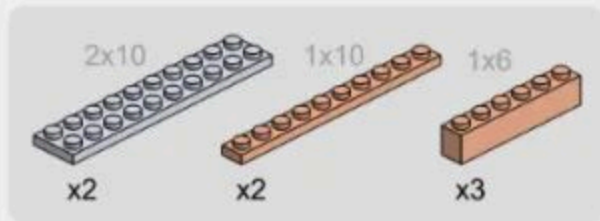

1-11

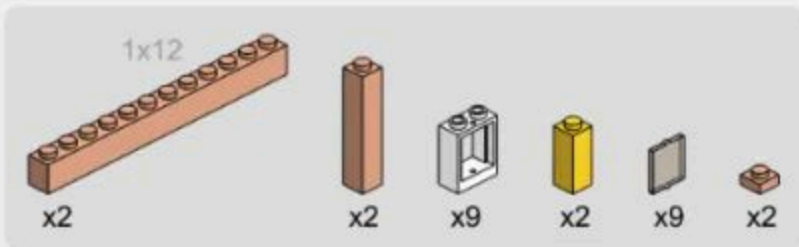

1-12

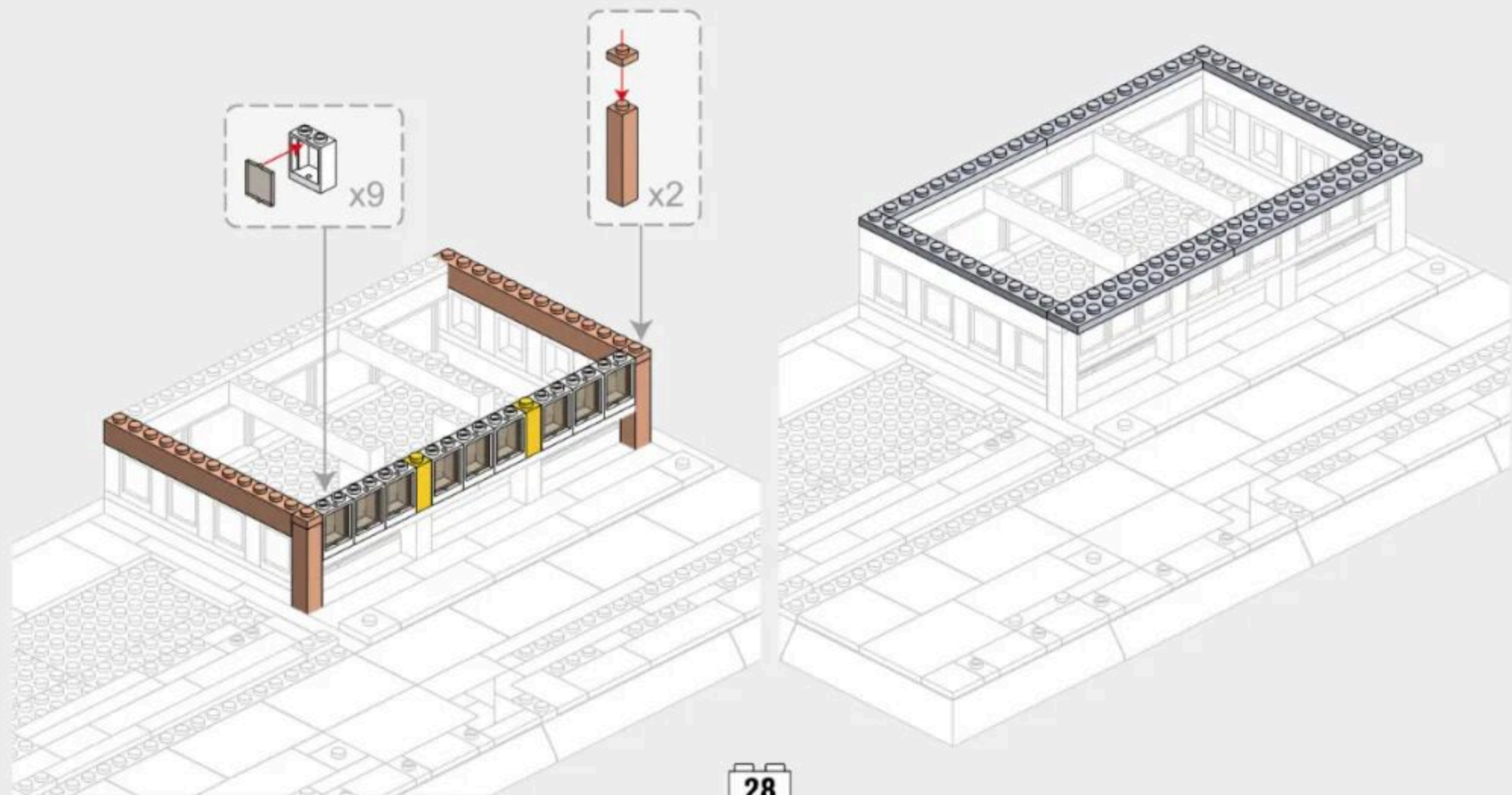
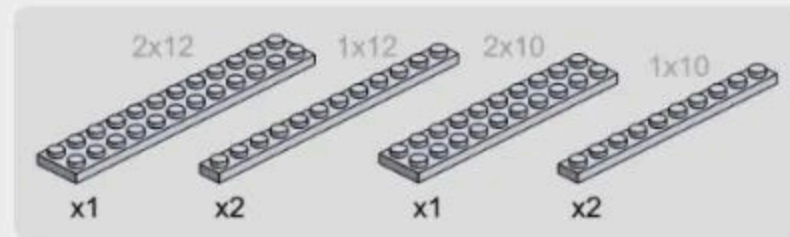



269PCS

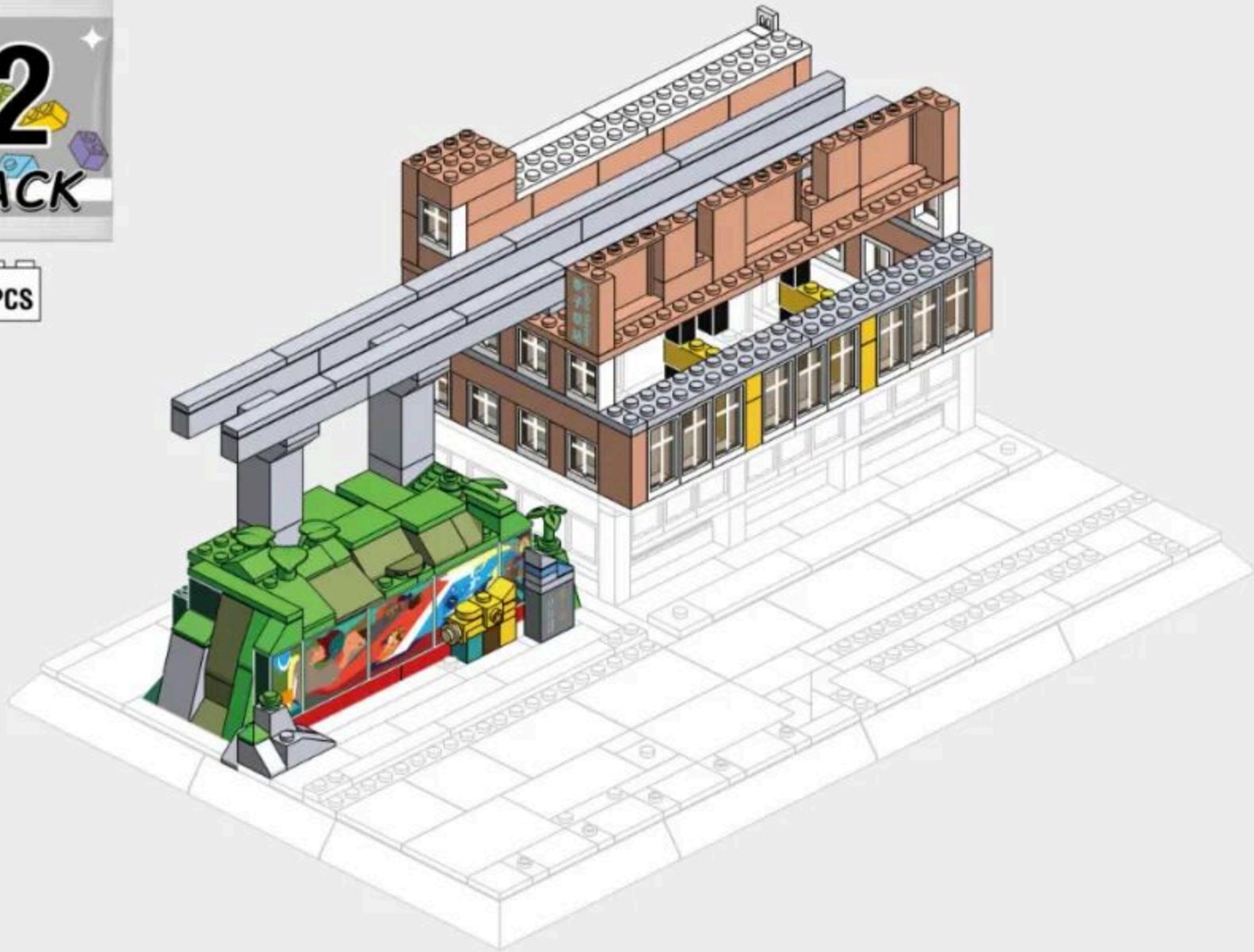

2-1

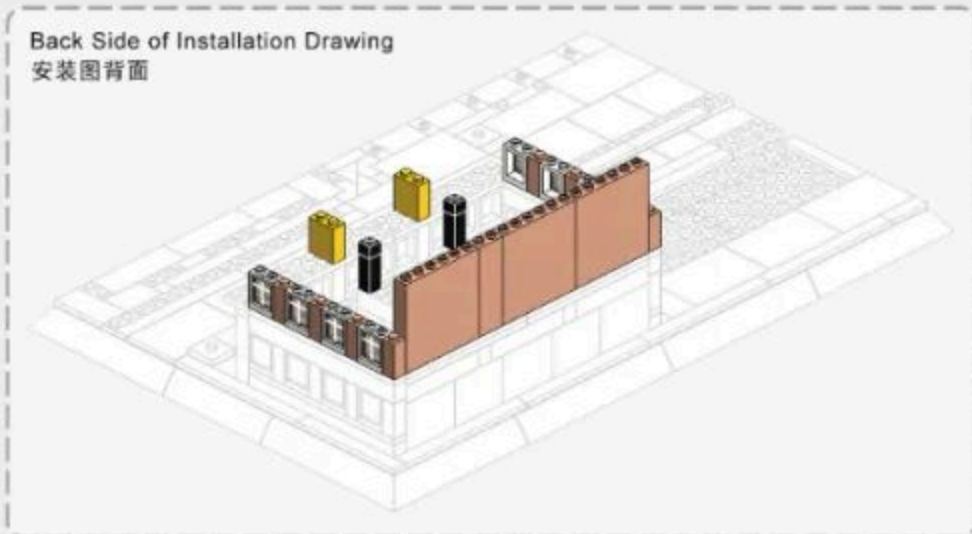

2-2

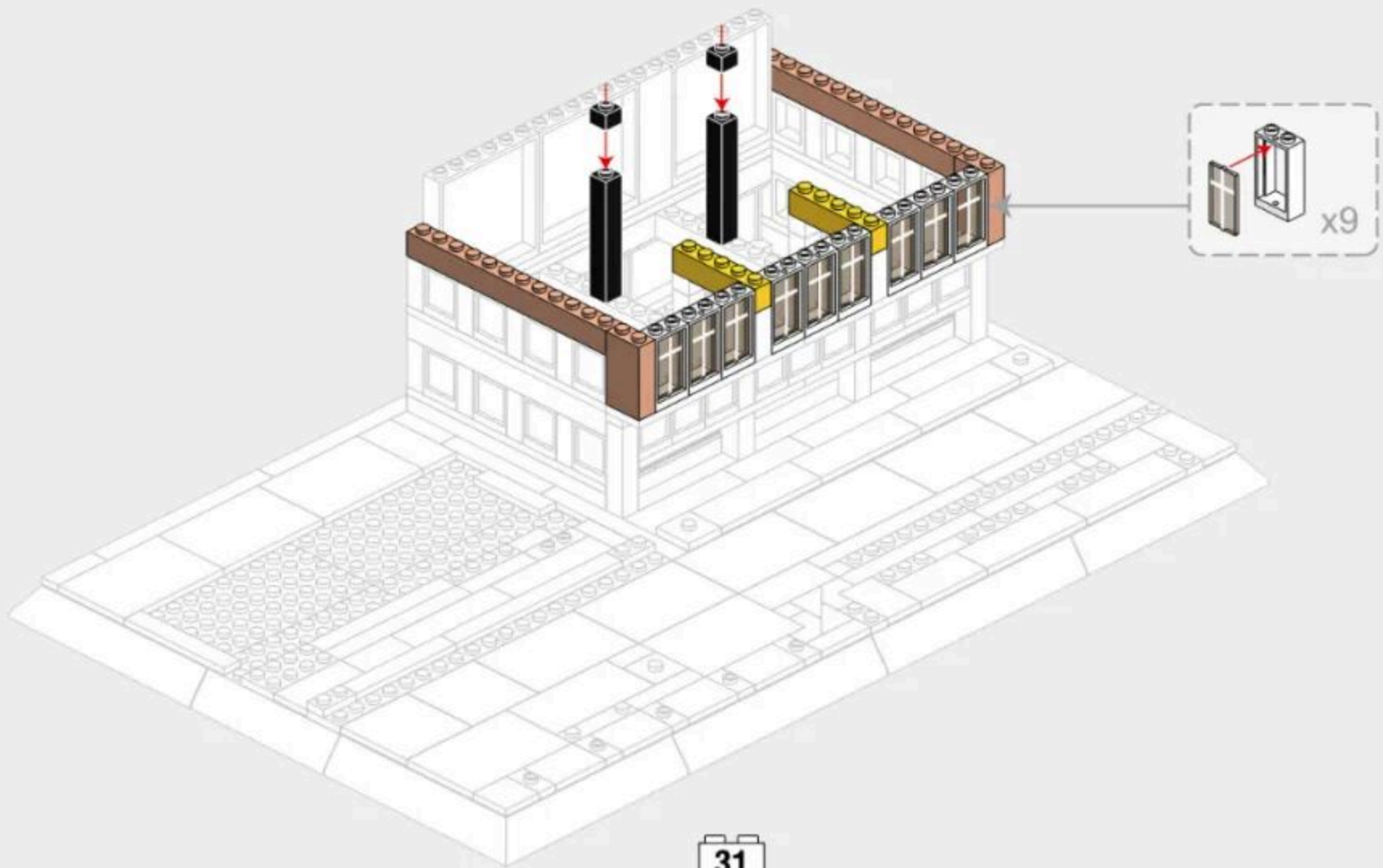
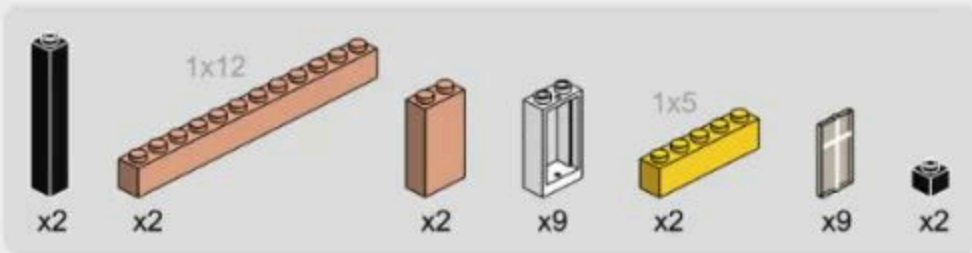

2-3

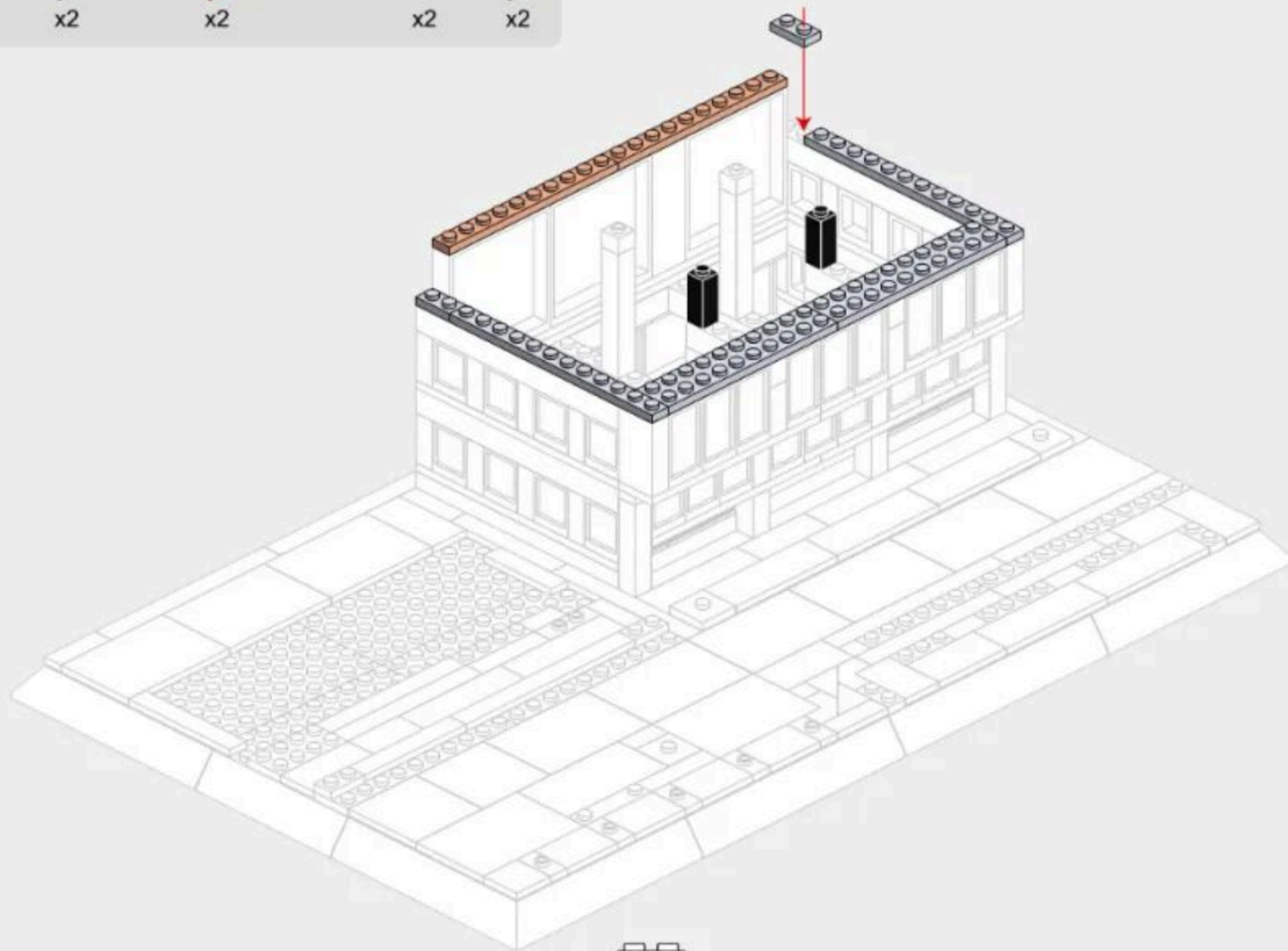
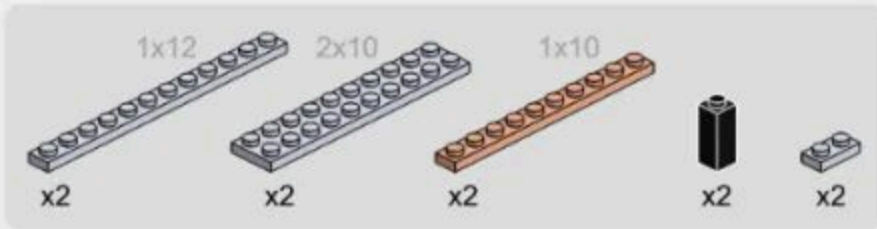

2-4

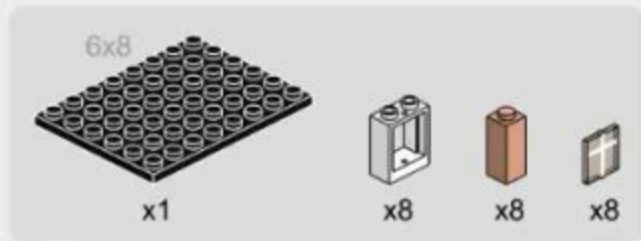

2-5

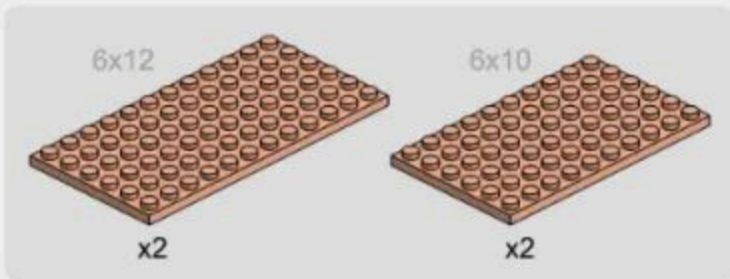

2-6

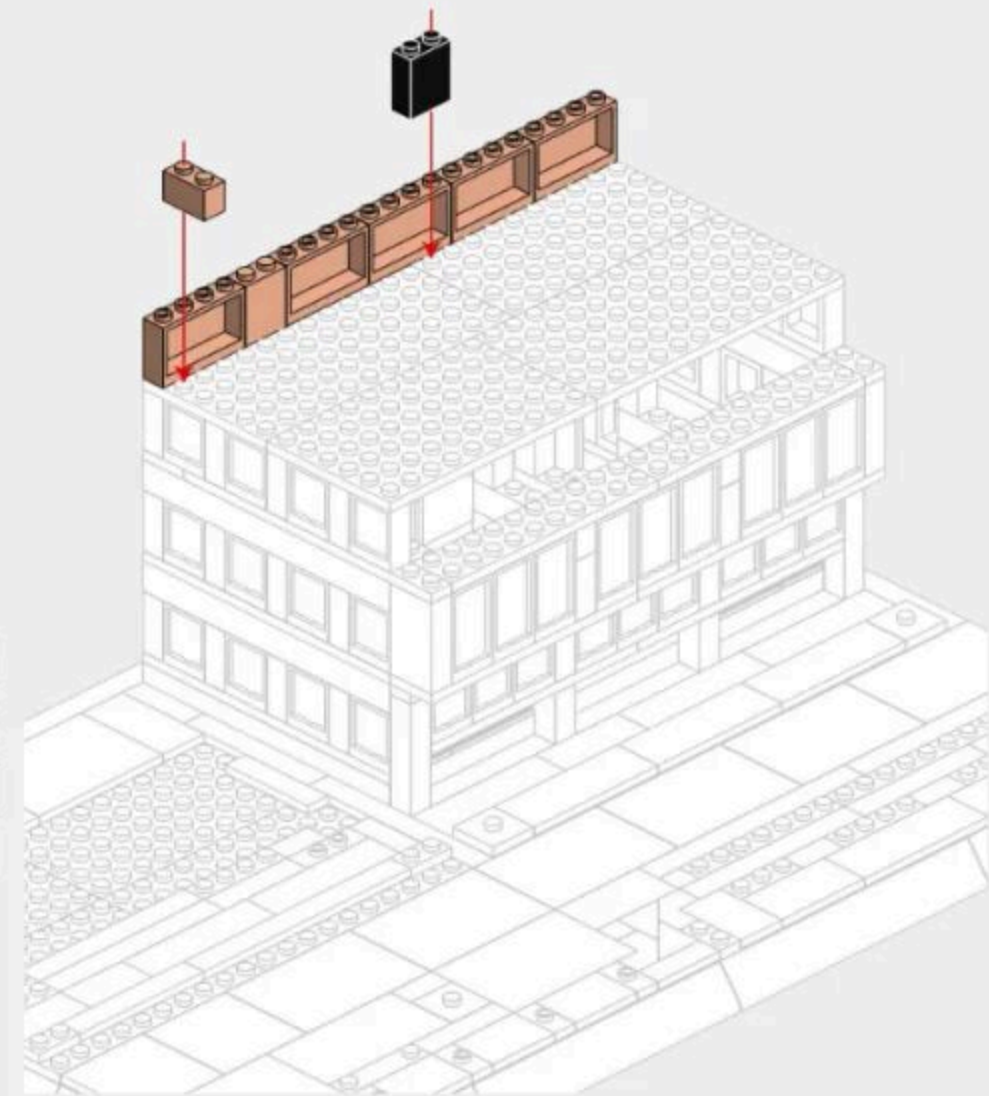

2-7

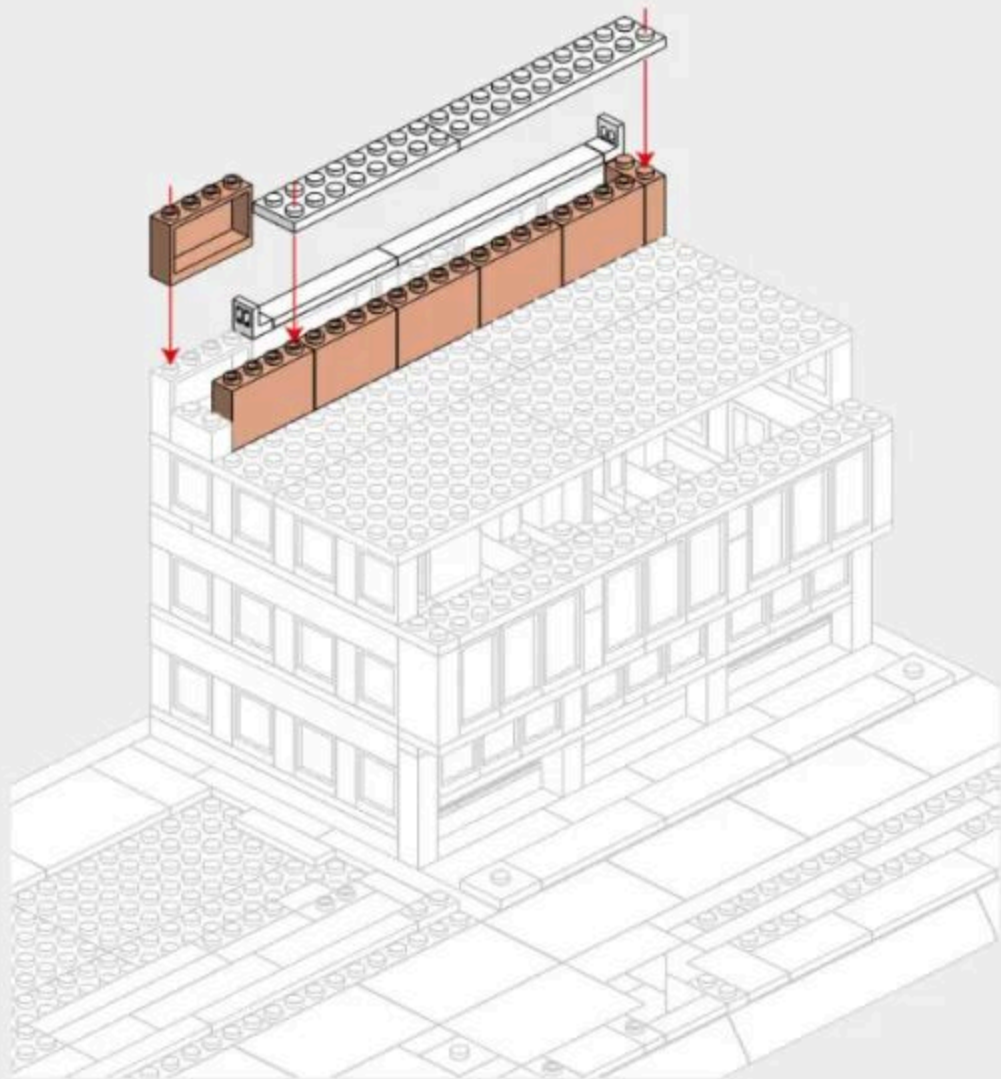
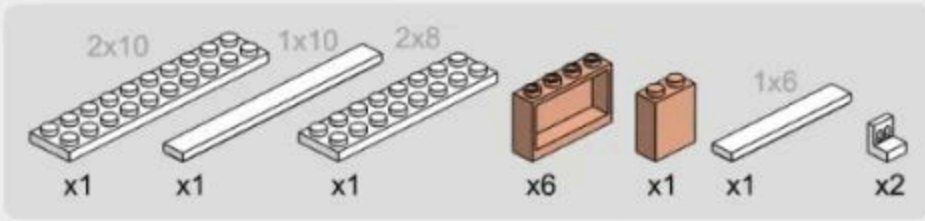

2-8

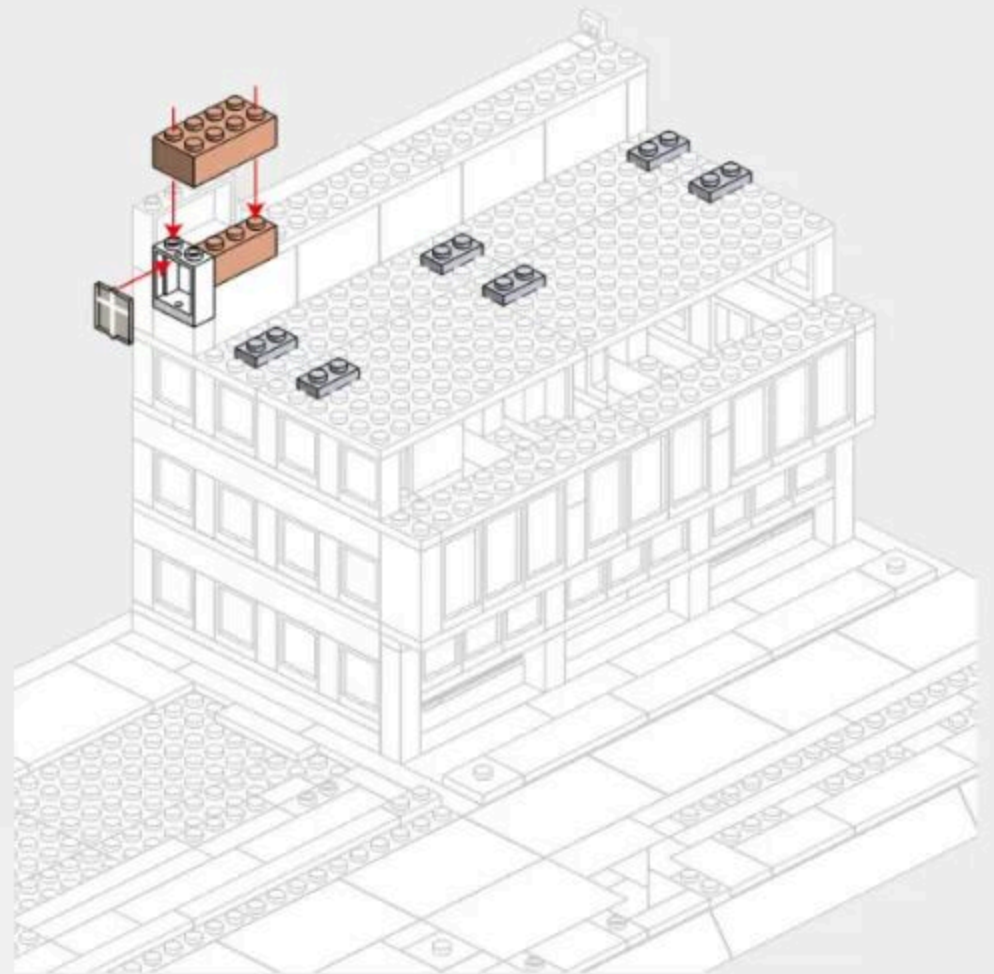
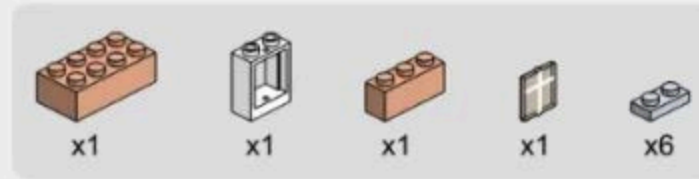

2-9

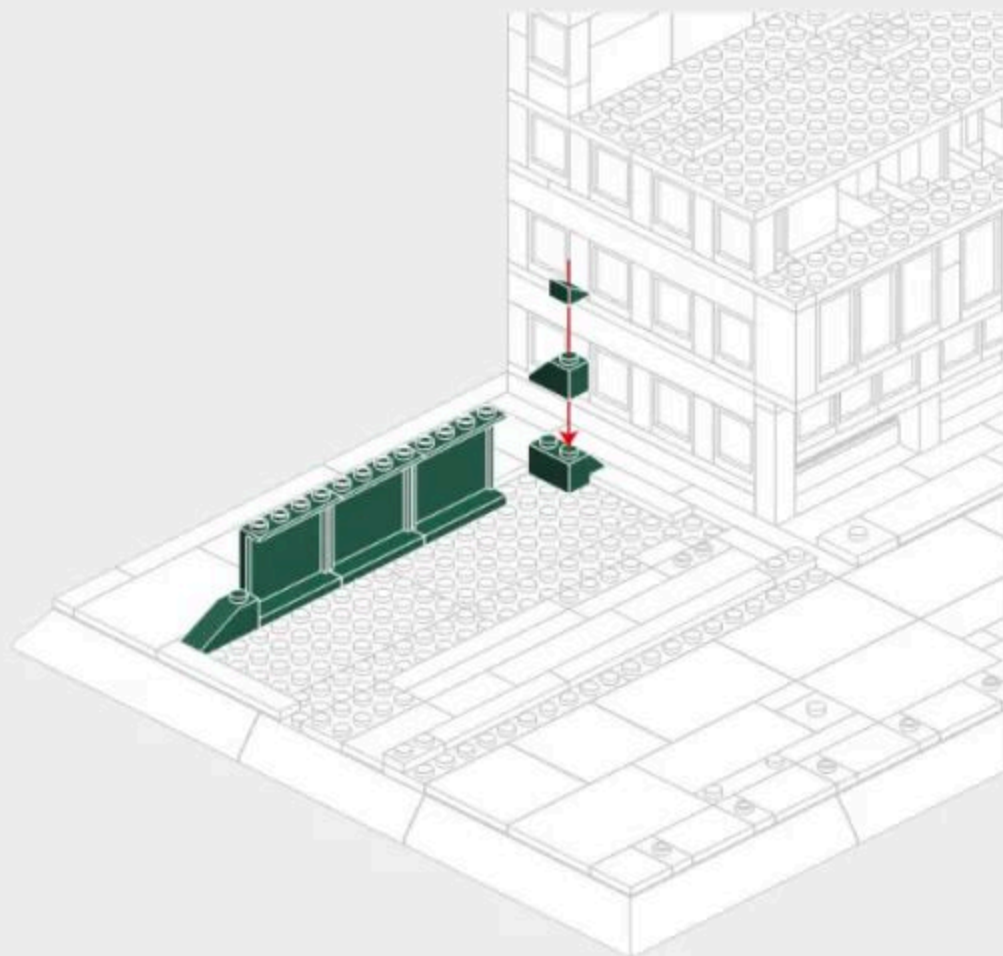

2-10

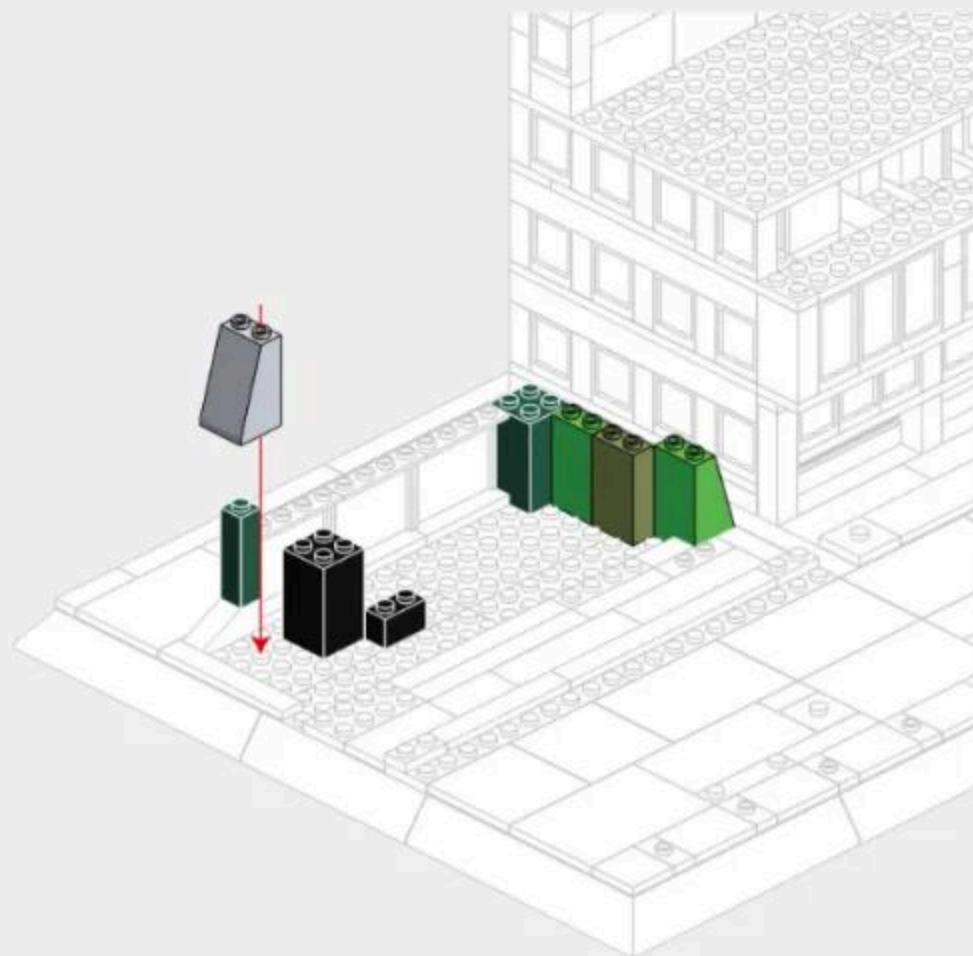
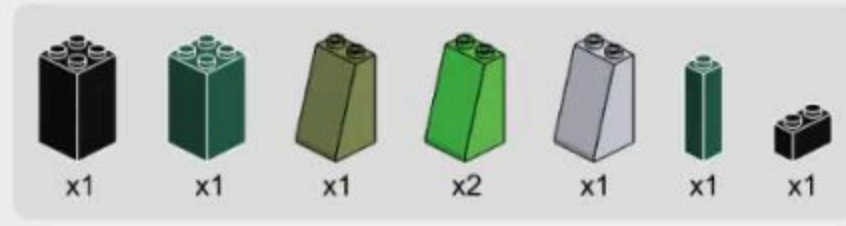

2-11

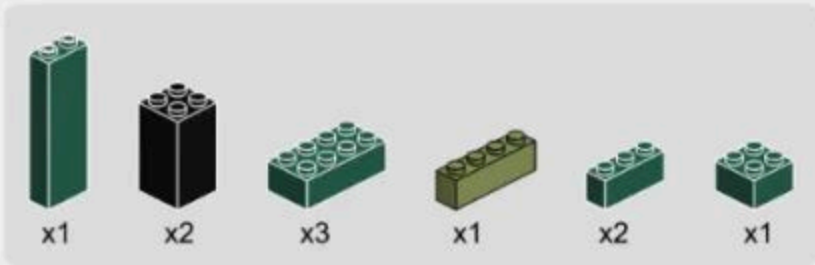

2-12

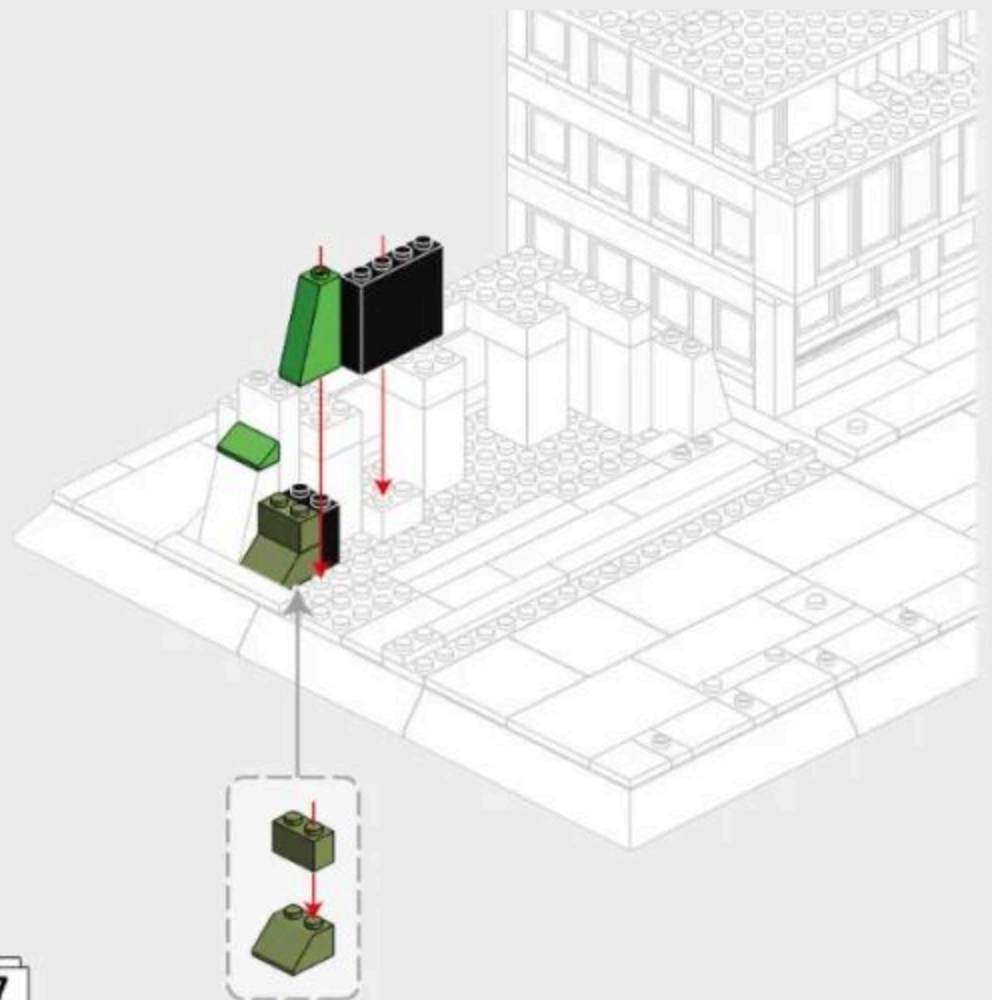
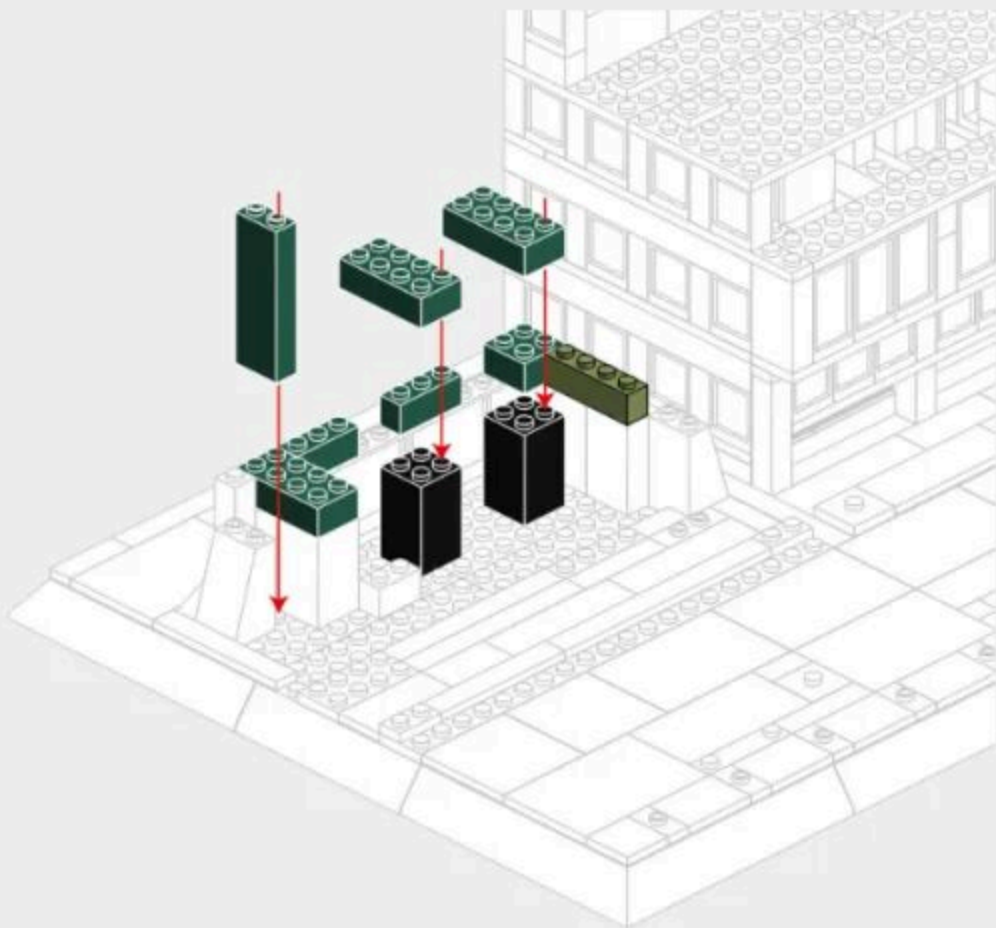
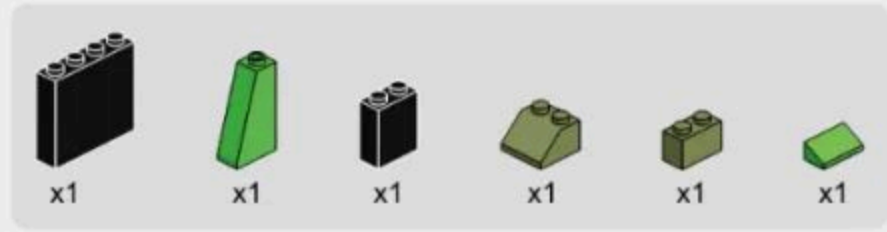

2-13

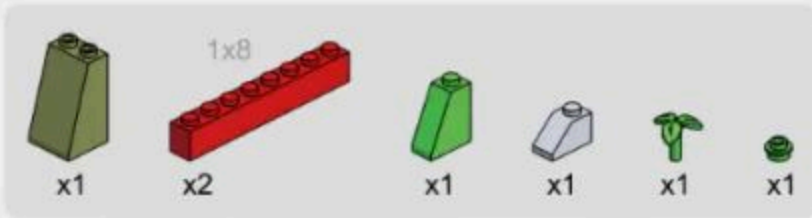

2-14

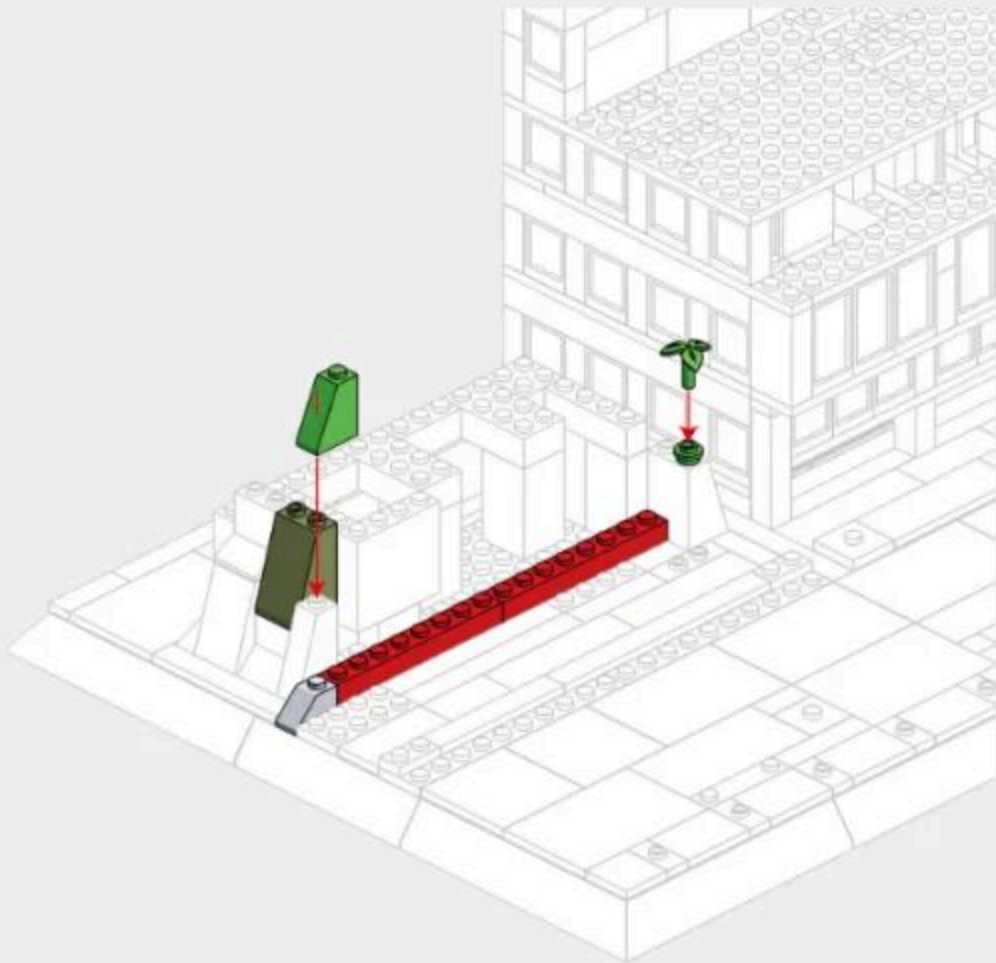

2-15

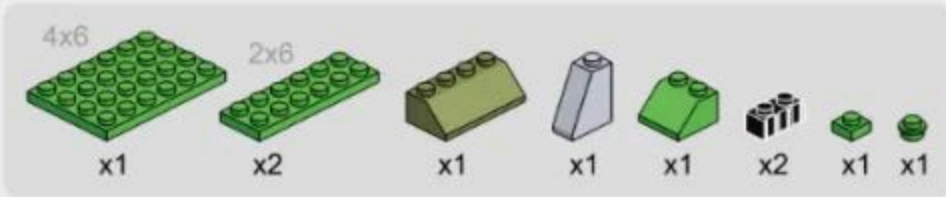

2-16

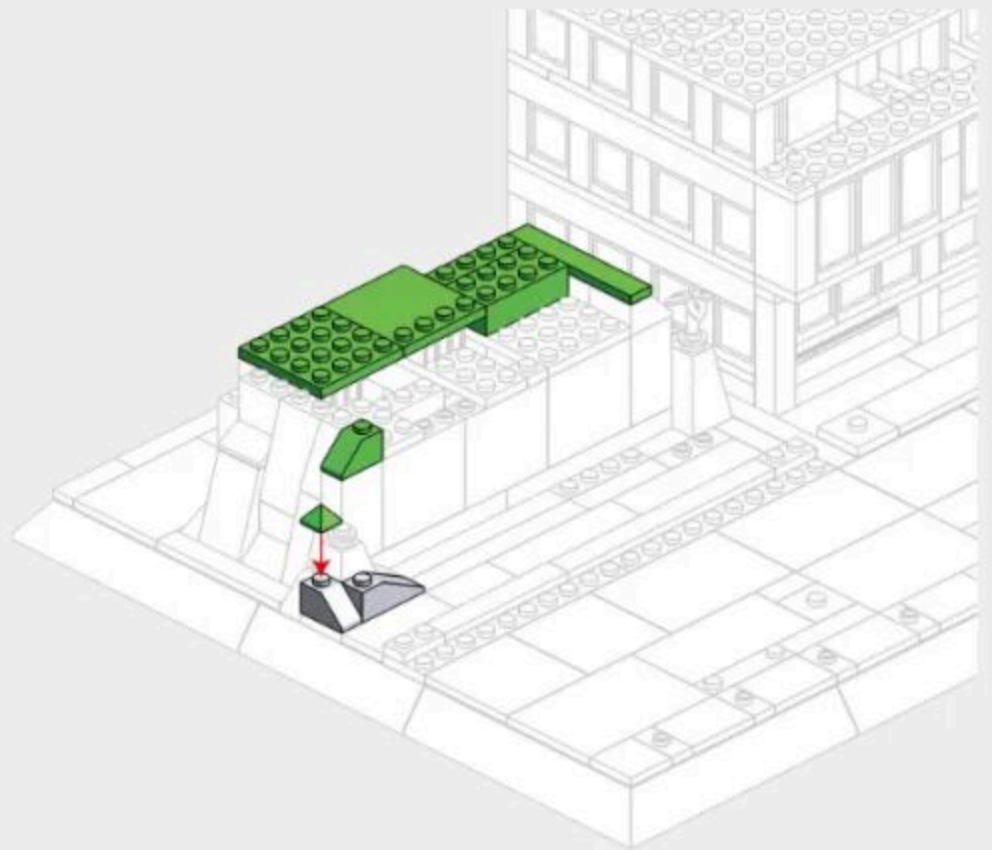
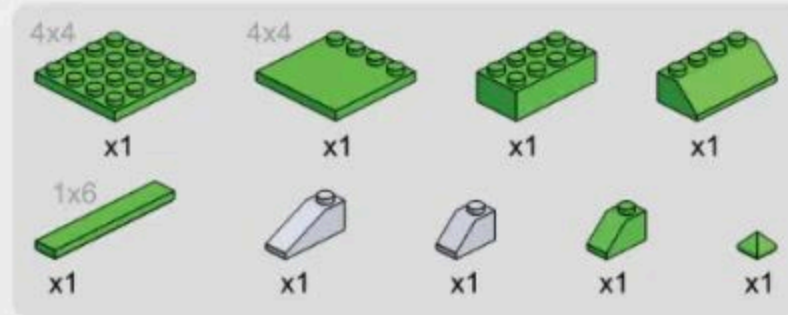

2-17



2-18

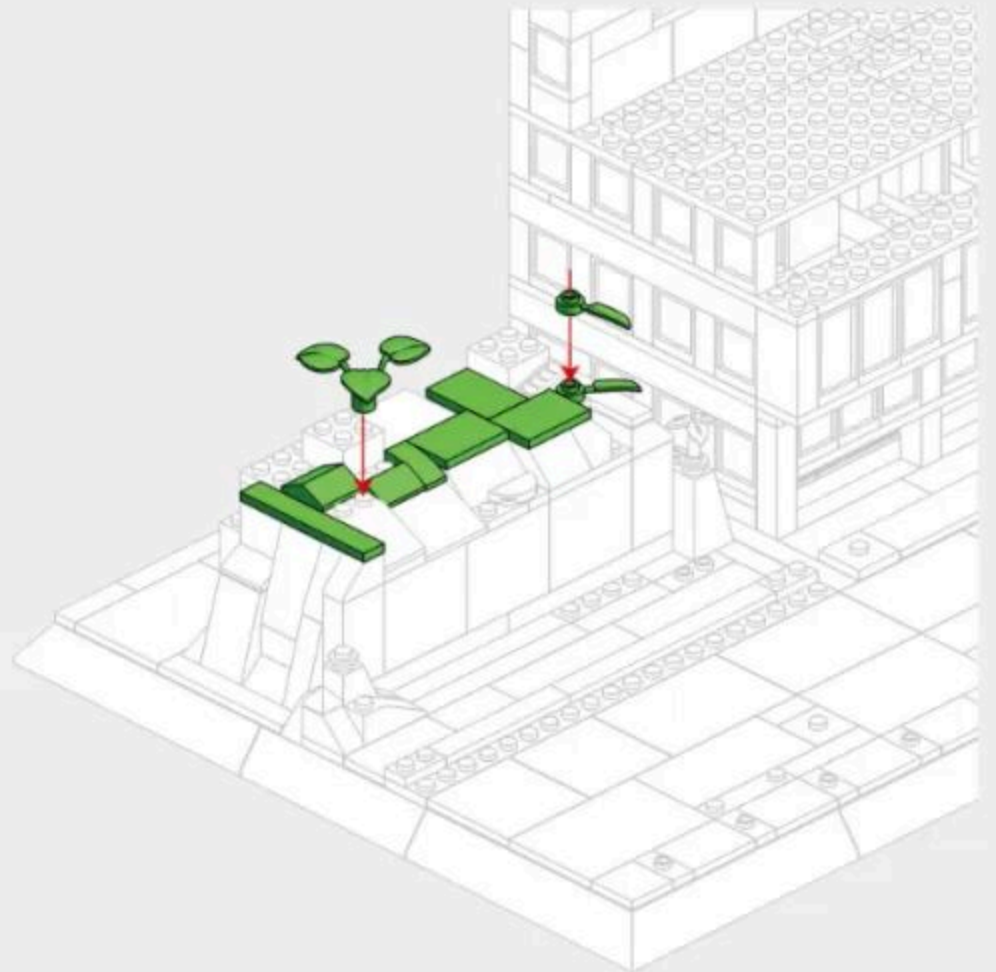
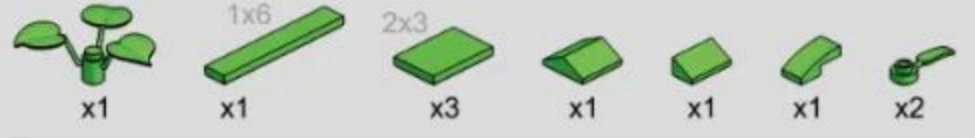

2-19

- x2 [Grey 1x4 Technic Brick]
- x1 [Grey 1x2 Technic Brick]
- x2 [Grey 1x6 Technic Brick]
- x4 [Grey 1x4 Technic Brick with Slope]
- x1 [Yellow 1x3 Technic Brick]
- x2 [Grey 2x2 Technic Plate]
- x1 [Yellow 1x2 Technic Brick]
- x1 [Brown 1x2 Technic Brick]
- x1 [Teal 1x2 Technic Brick]
- x2 [Yellow 1x2 Technic Brick with Pin Hole]
- x1 [Grey 1x2 Technic Brick]
- x1 [Yellow 1x2 Technic Brick]
- x1 [Yellow 1x2 Technic Brick]
- x1 [Blue 1x2 Technic Brick]
- x1 [Grey 1x2 Technic Brick]
- x1 [Grey 1x2 Technic Brick]
- x1 [Blue 1x2 Technic Brick]
- x1 [Grey 1x2 Technic Brick]
- x1 [Yellow 1x2 Technic Brick]
- x1 [Yellow 1x2 Technic Brick]

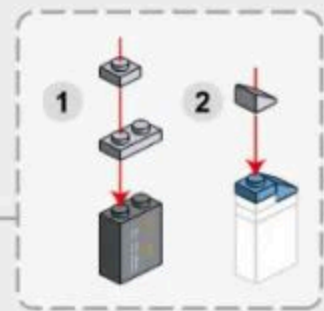
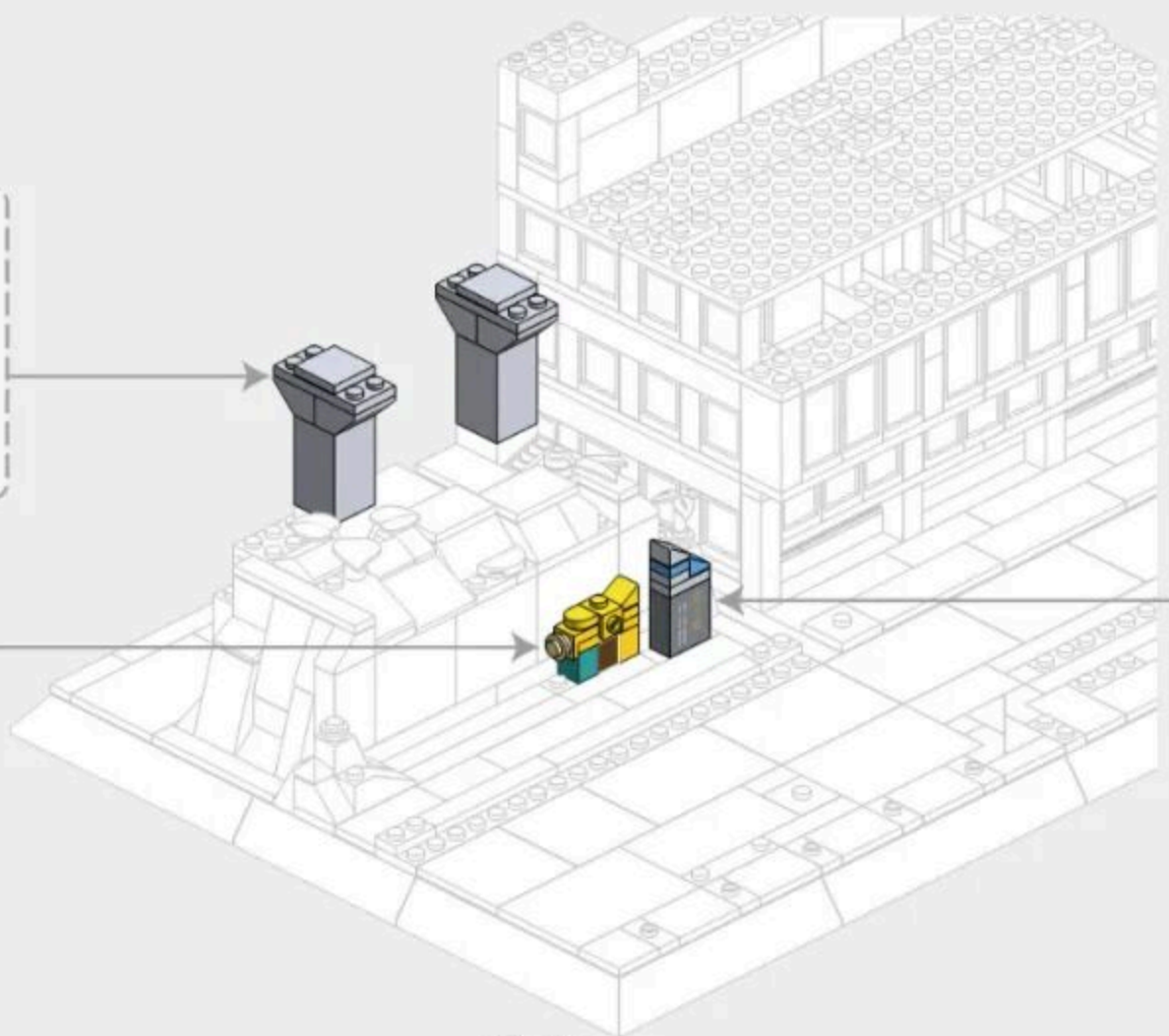
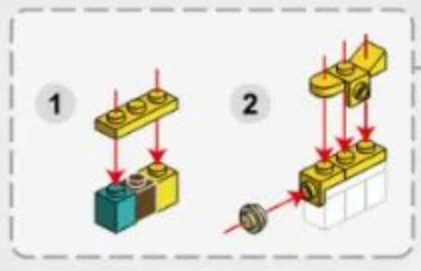
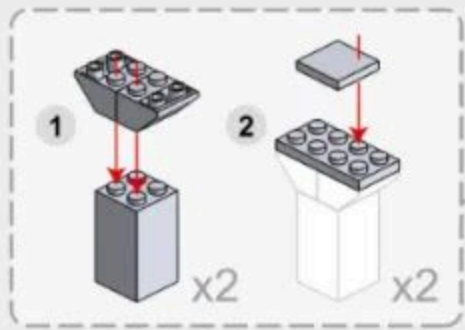

2-20

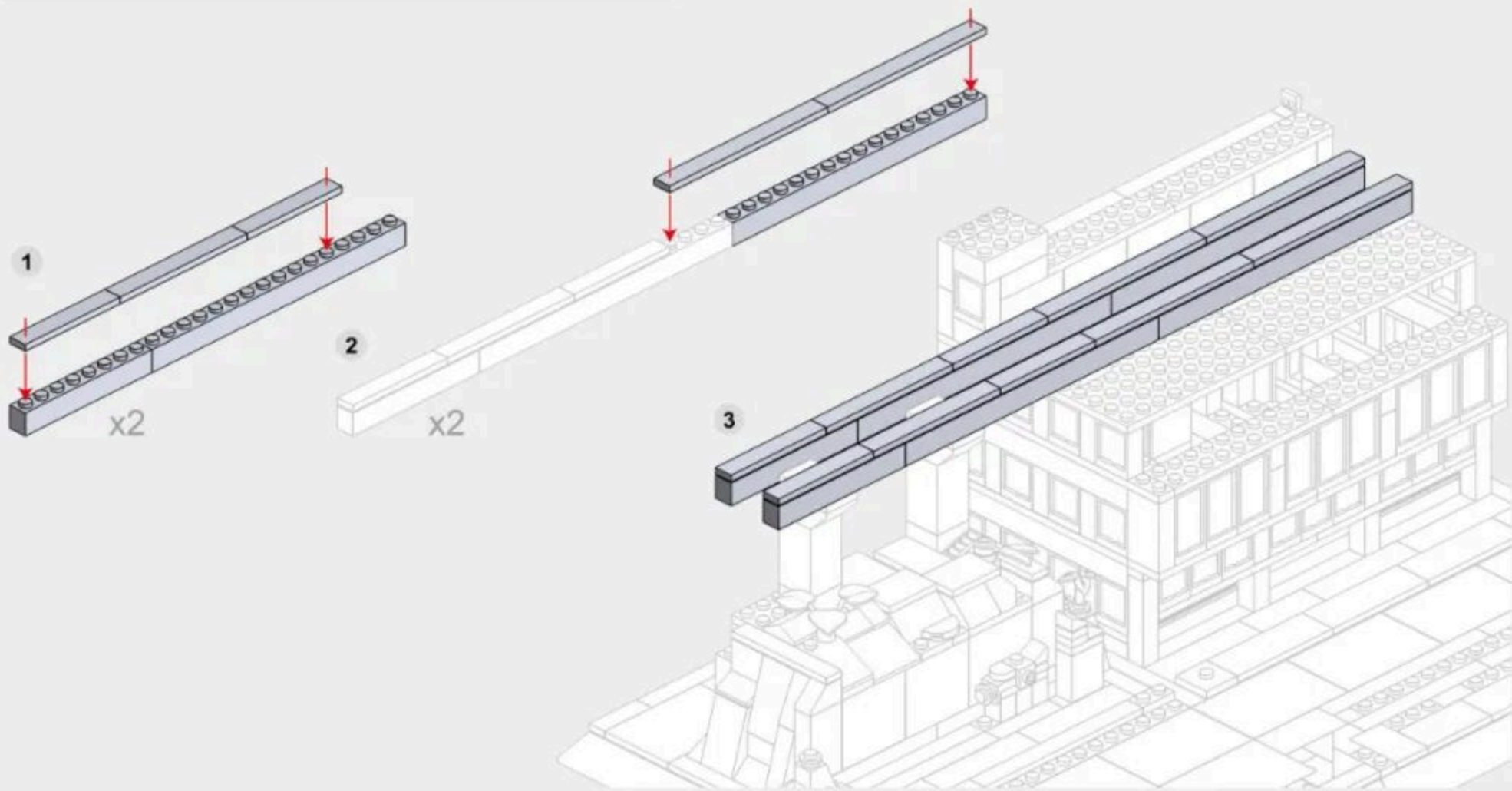
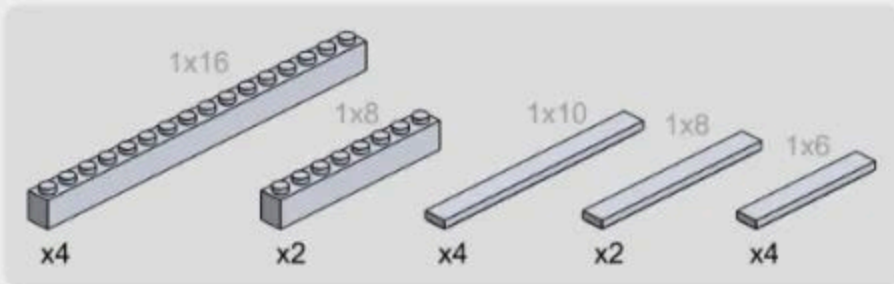

2-21

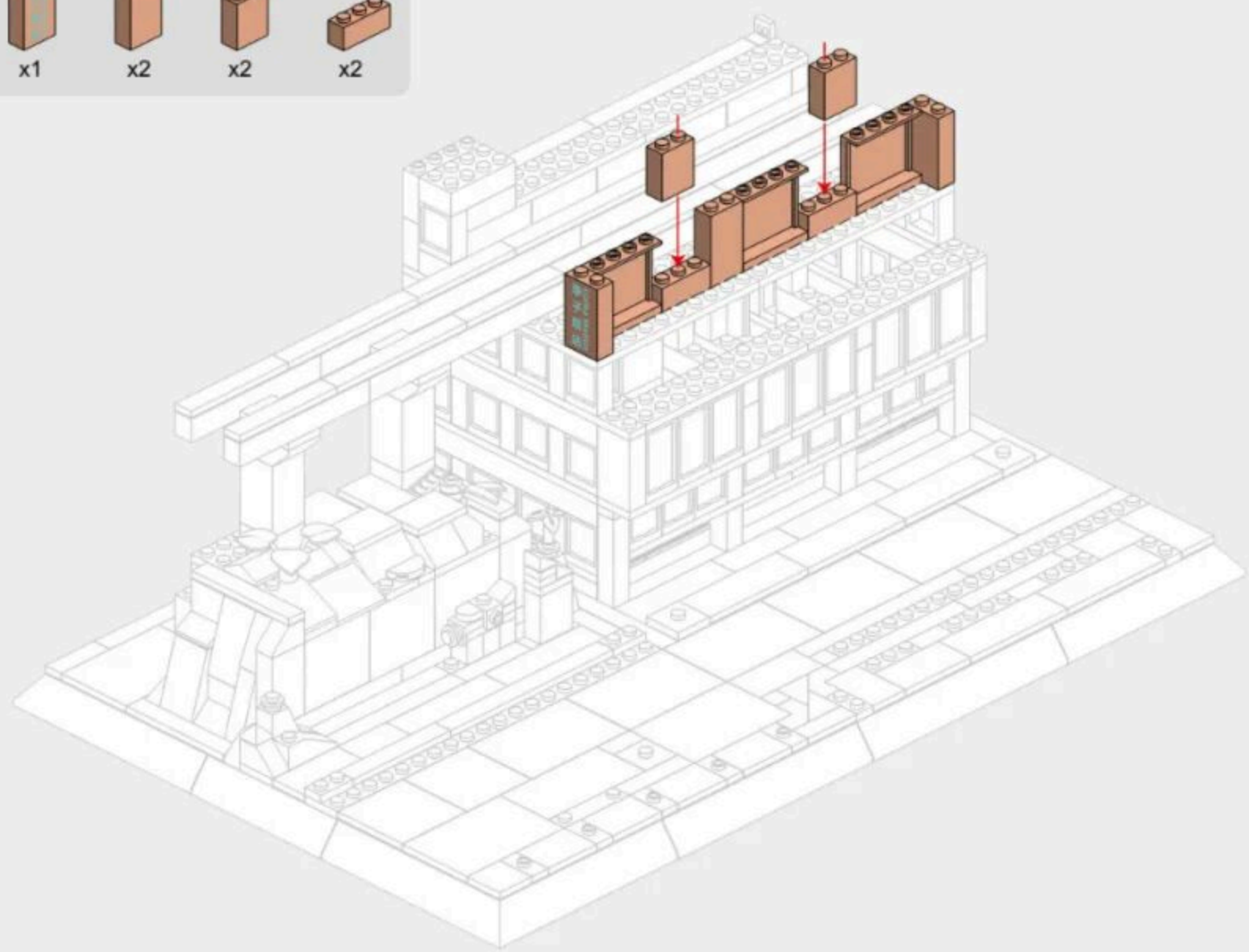
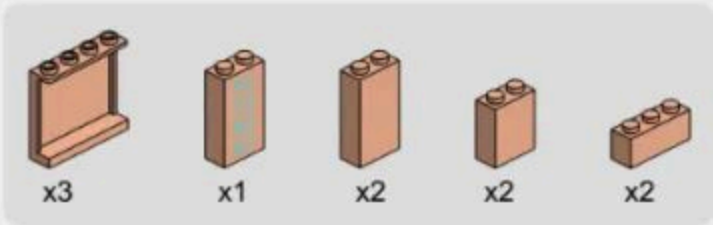



240PCS



3-1

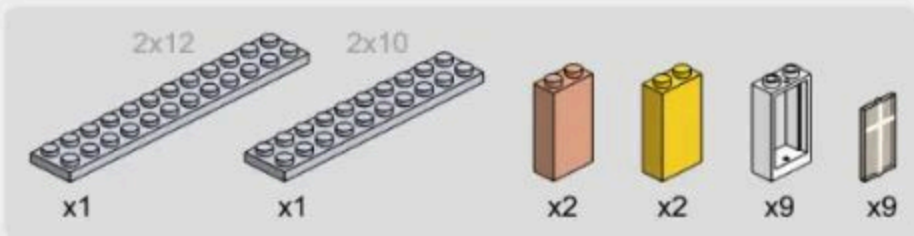

3-2

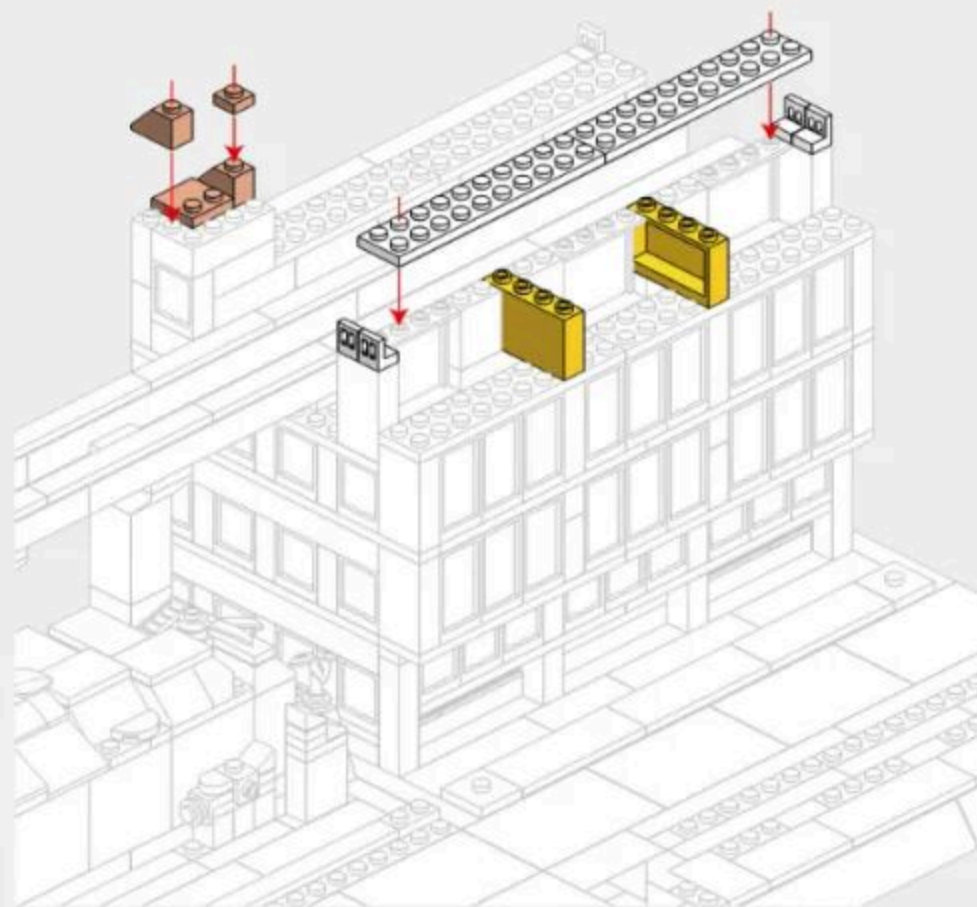
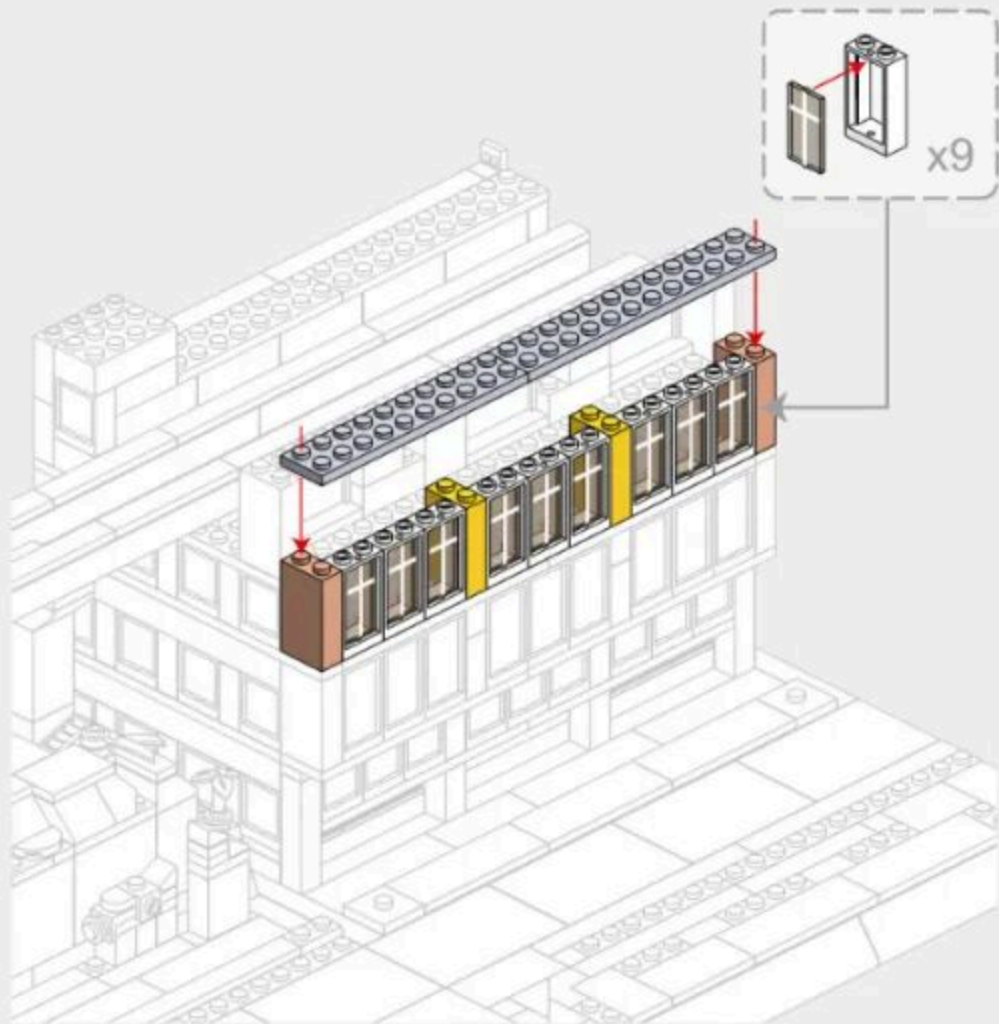

3-3

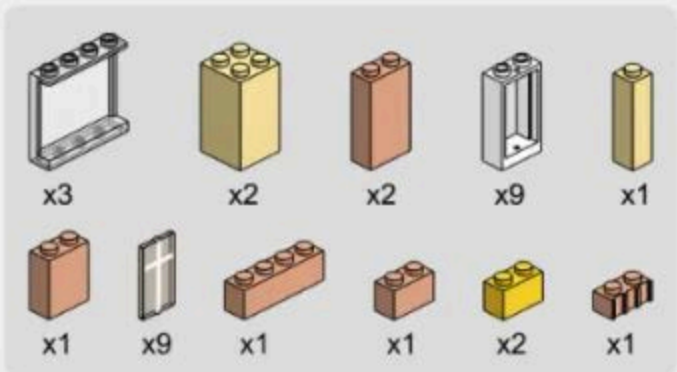

3-4

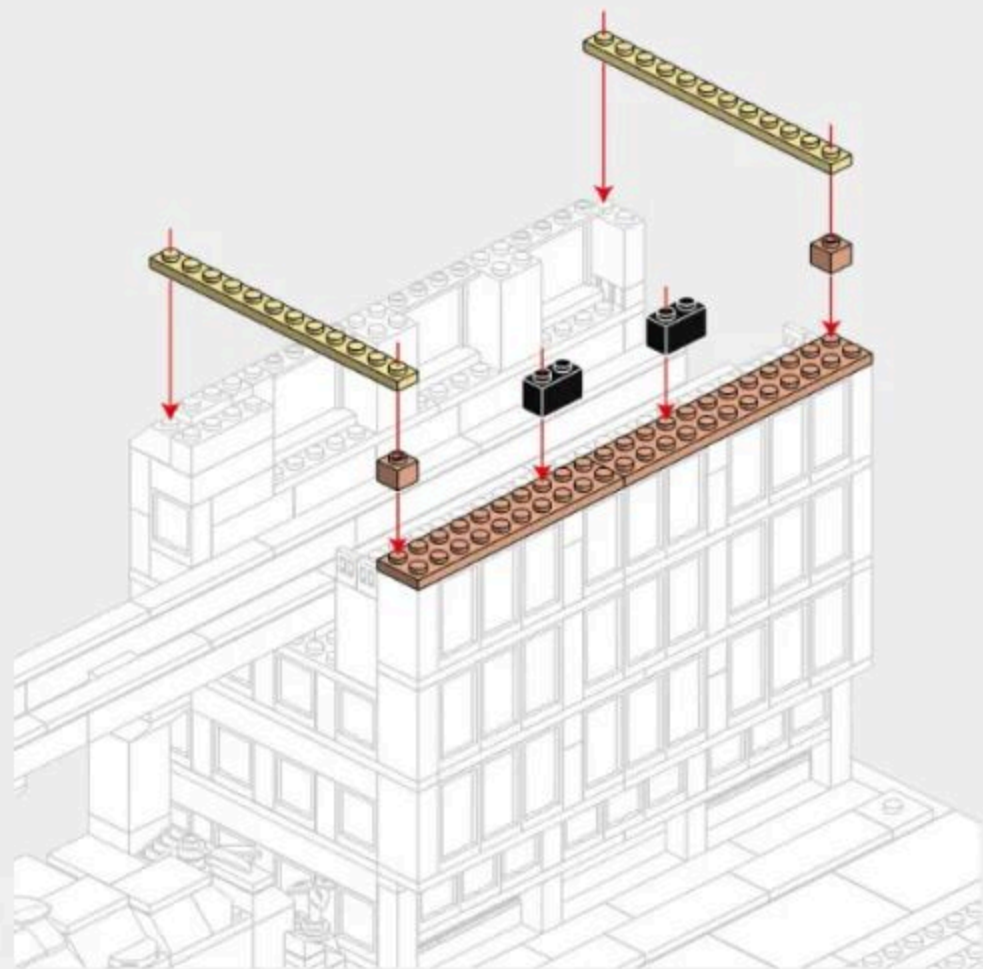
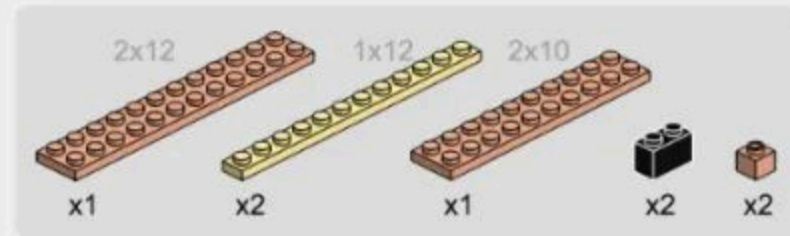



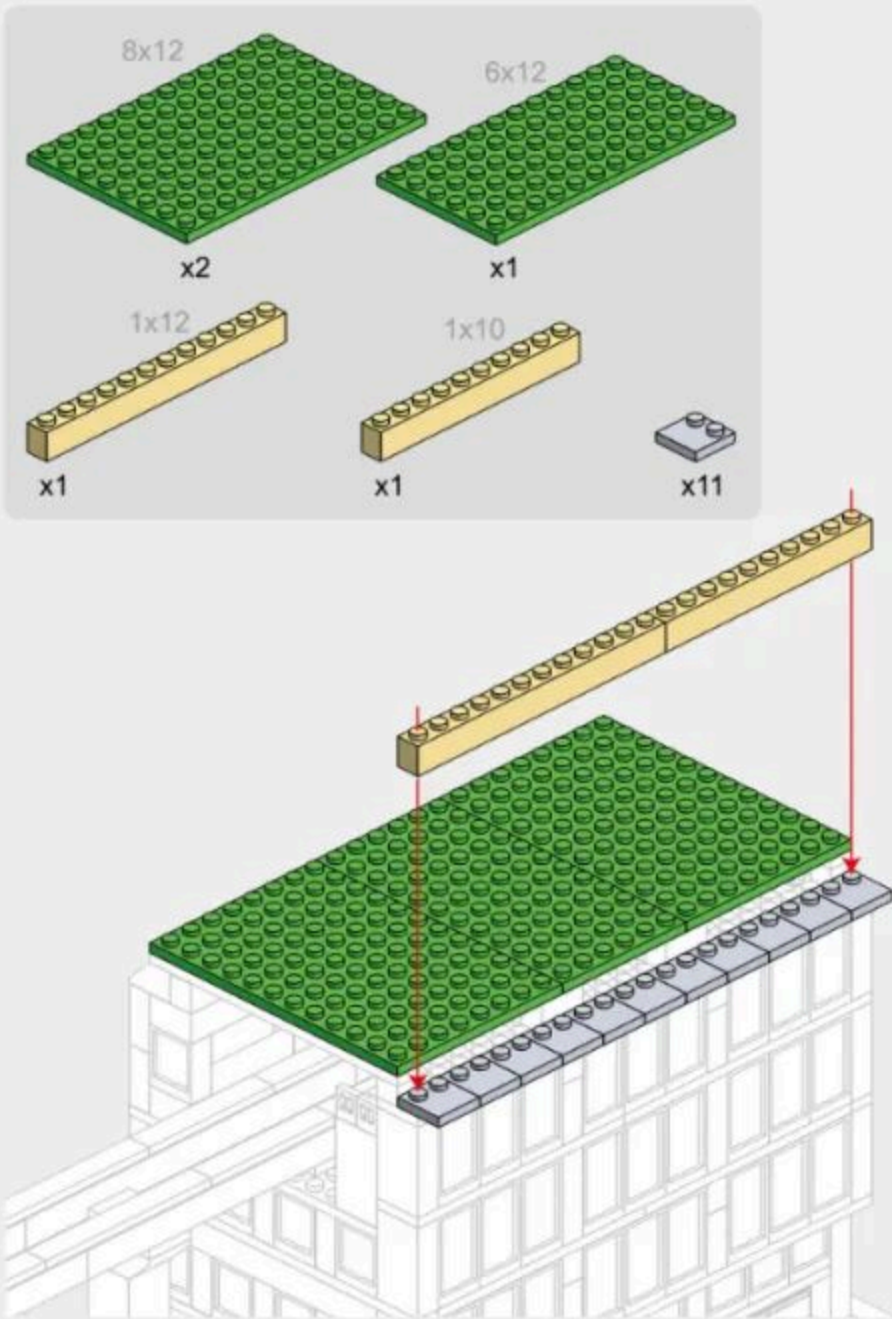

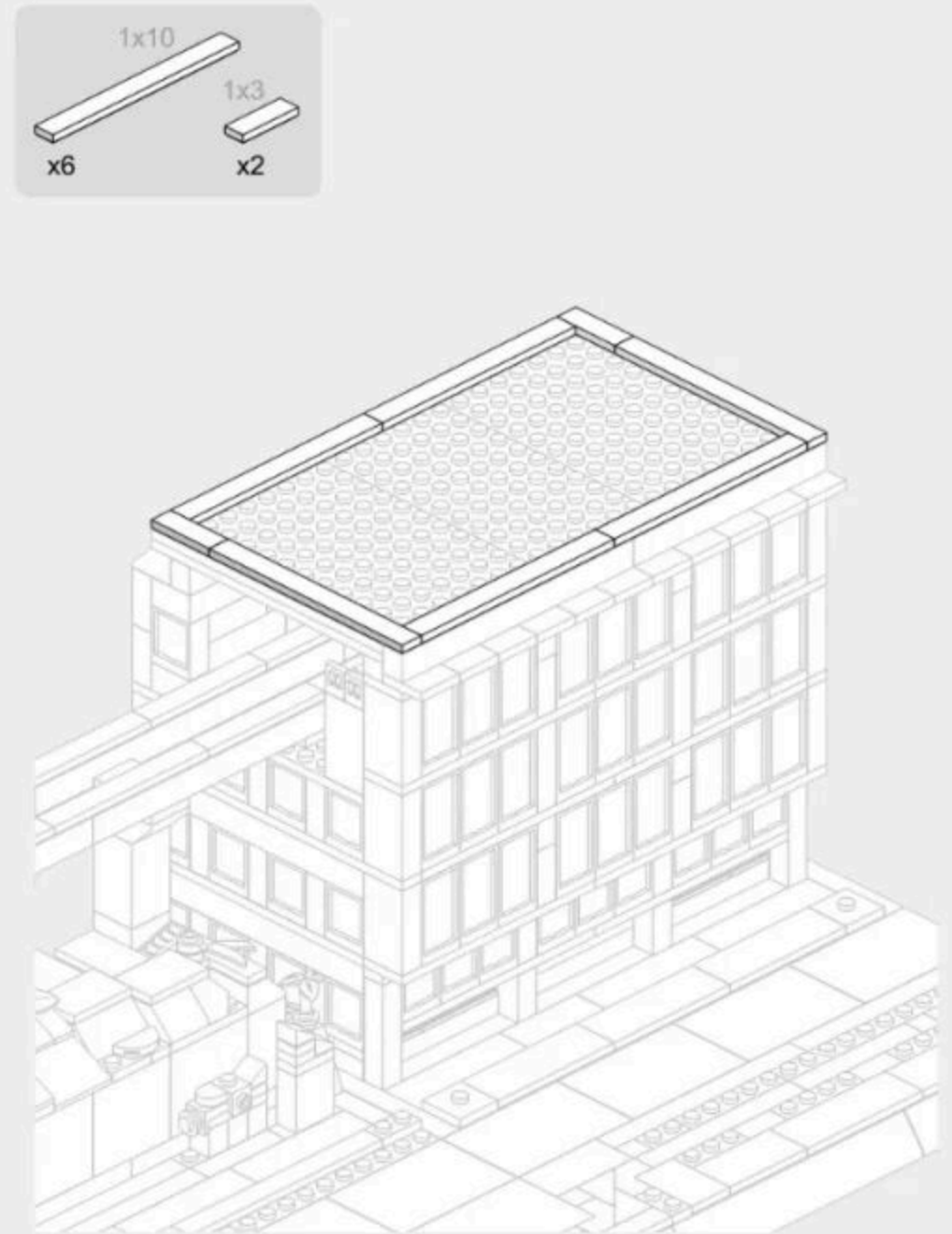

3-5



3-6







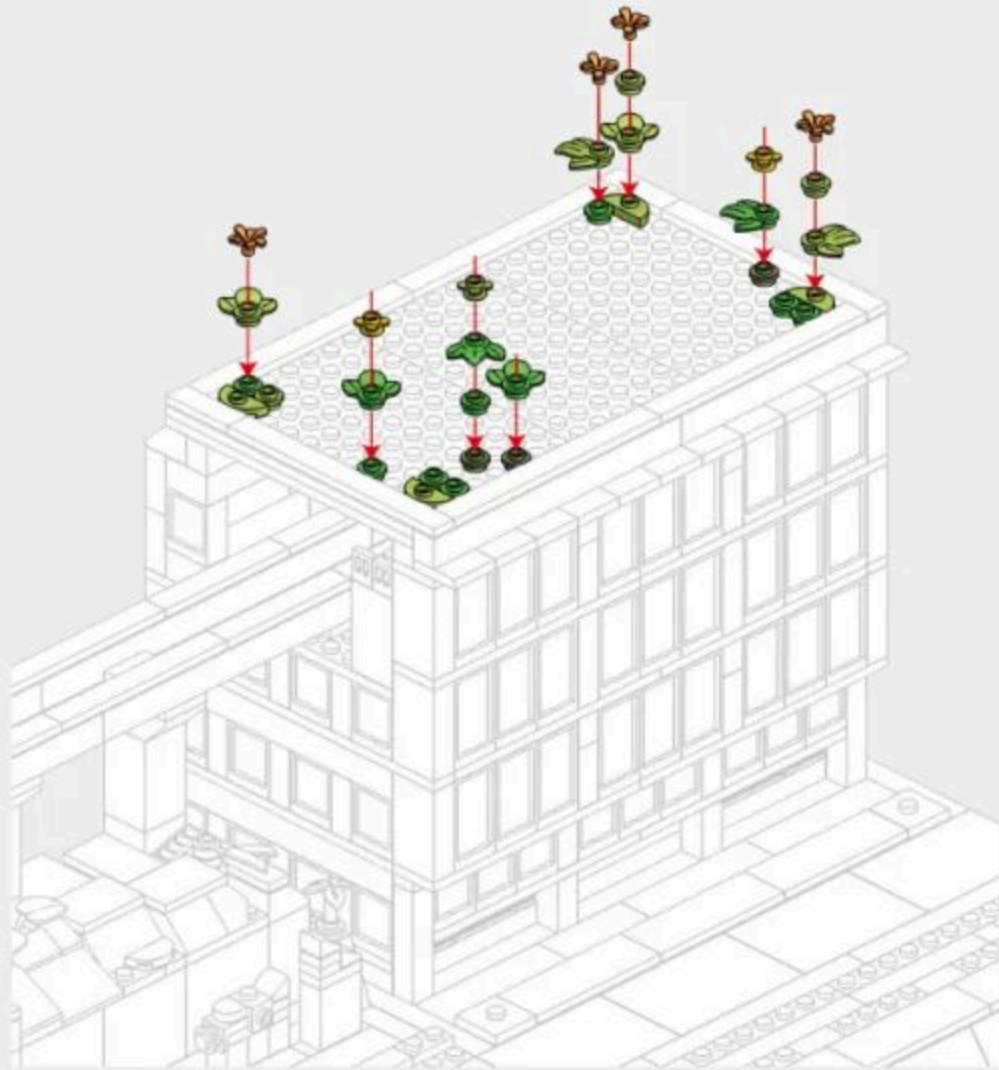



3-7

-  x4
-  x4
-  x4
-  x4
-  x1
-  x2
-  x3
-  x8
-  x3







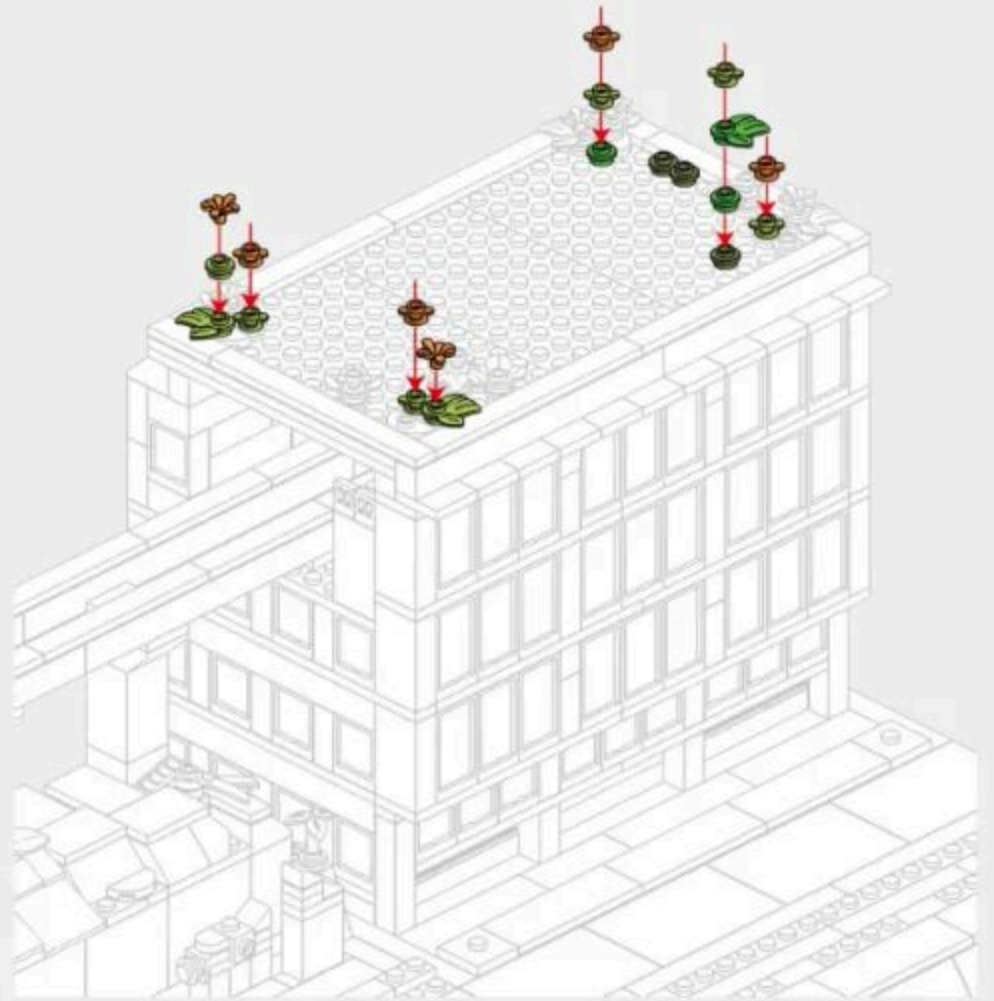

3-8

-  x2
-  x1
-  x2
-  x5
-  x4
-  x3
-  x2
-  x1



3-9

-  x5
-  x2
-  x2
-  x2
-  x3
-  x1



3-10

-  1x8 x2
-  x2
-  x4
-  x2

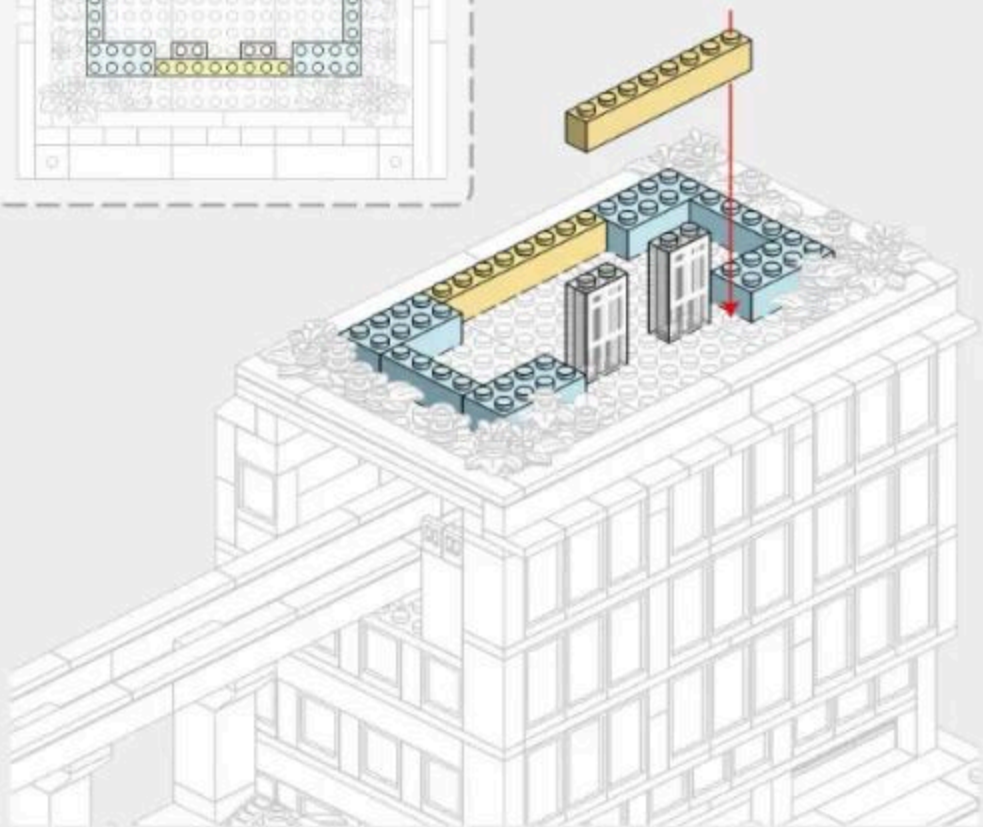

3-11

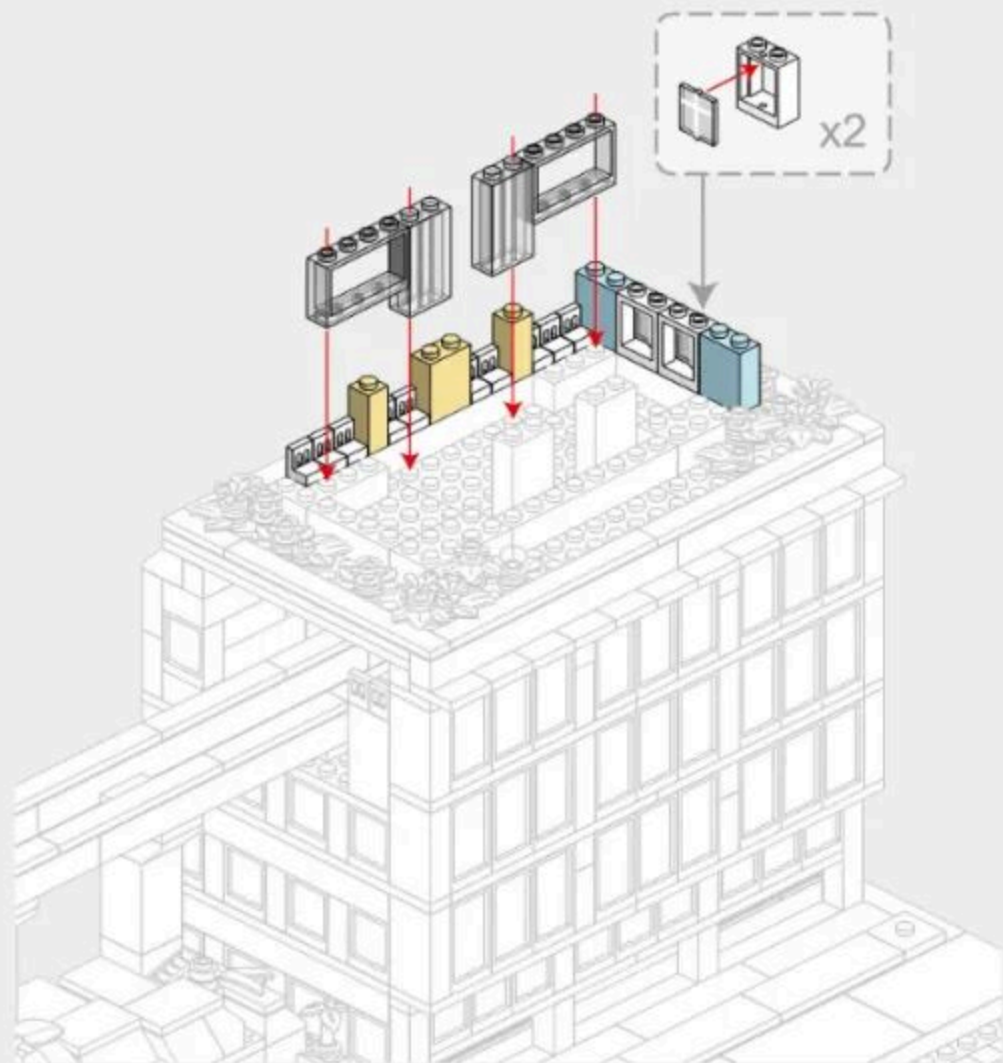

3-12

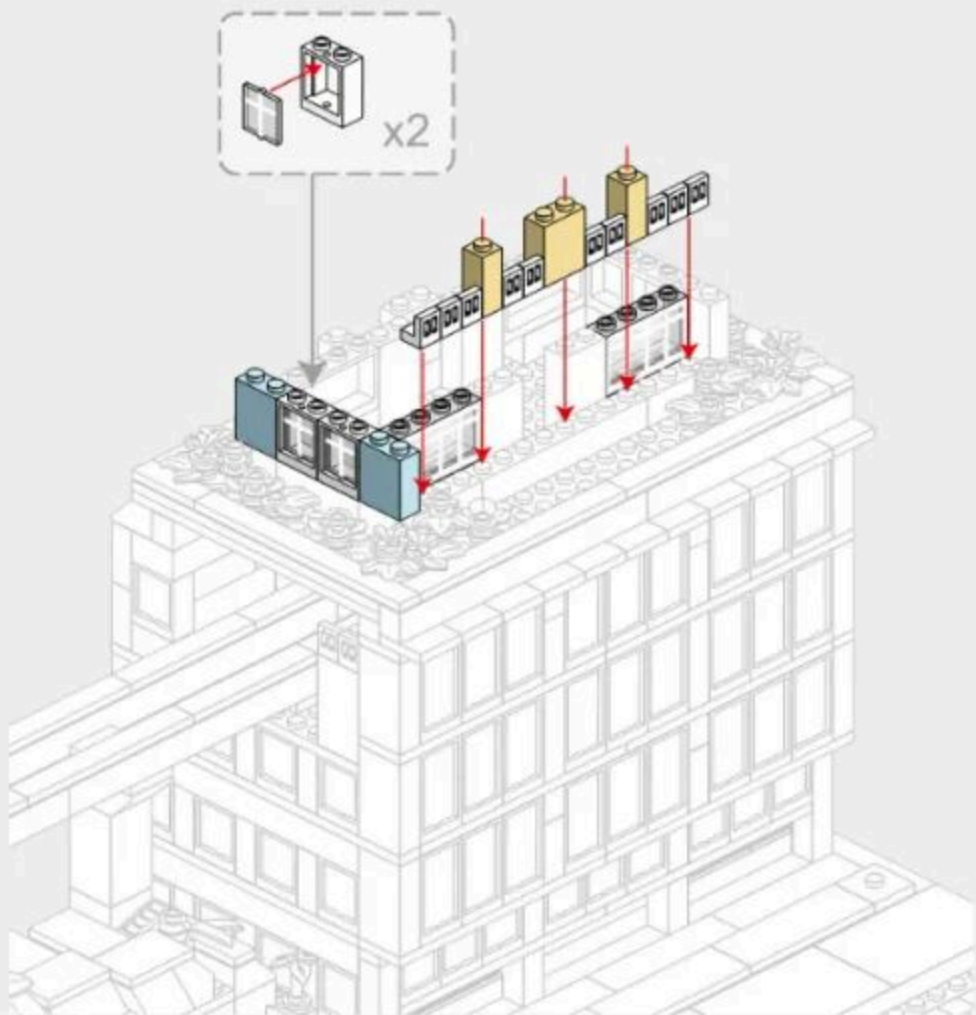

3-13

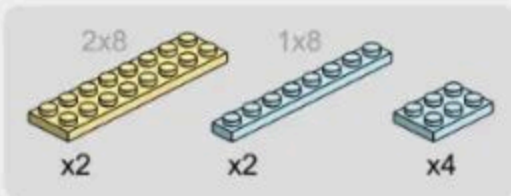

3-14

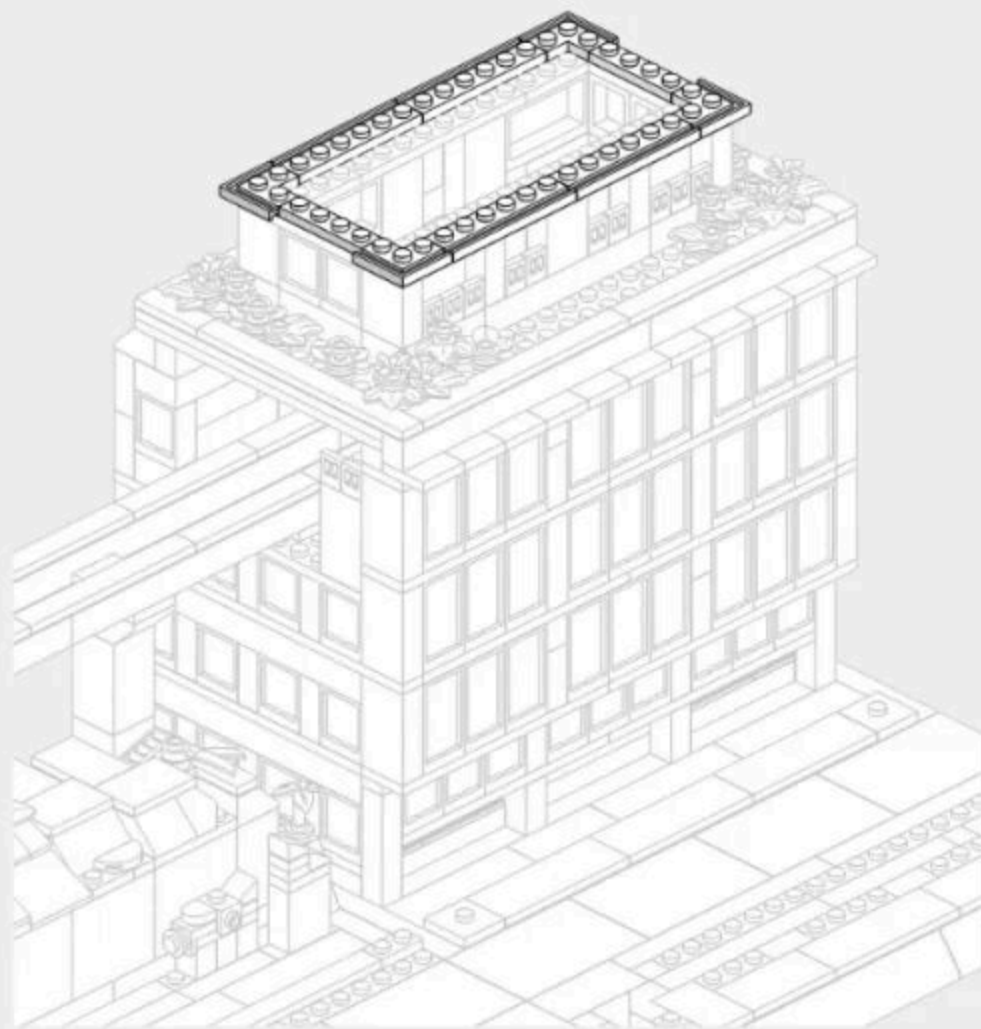



279PCS

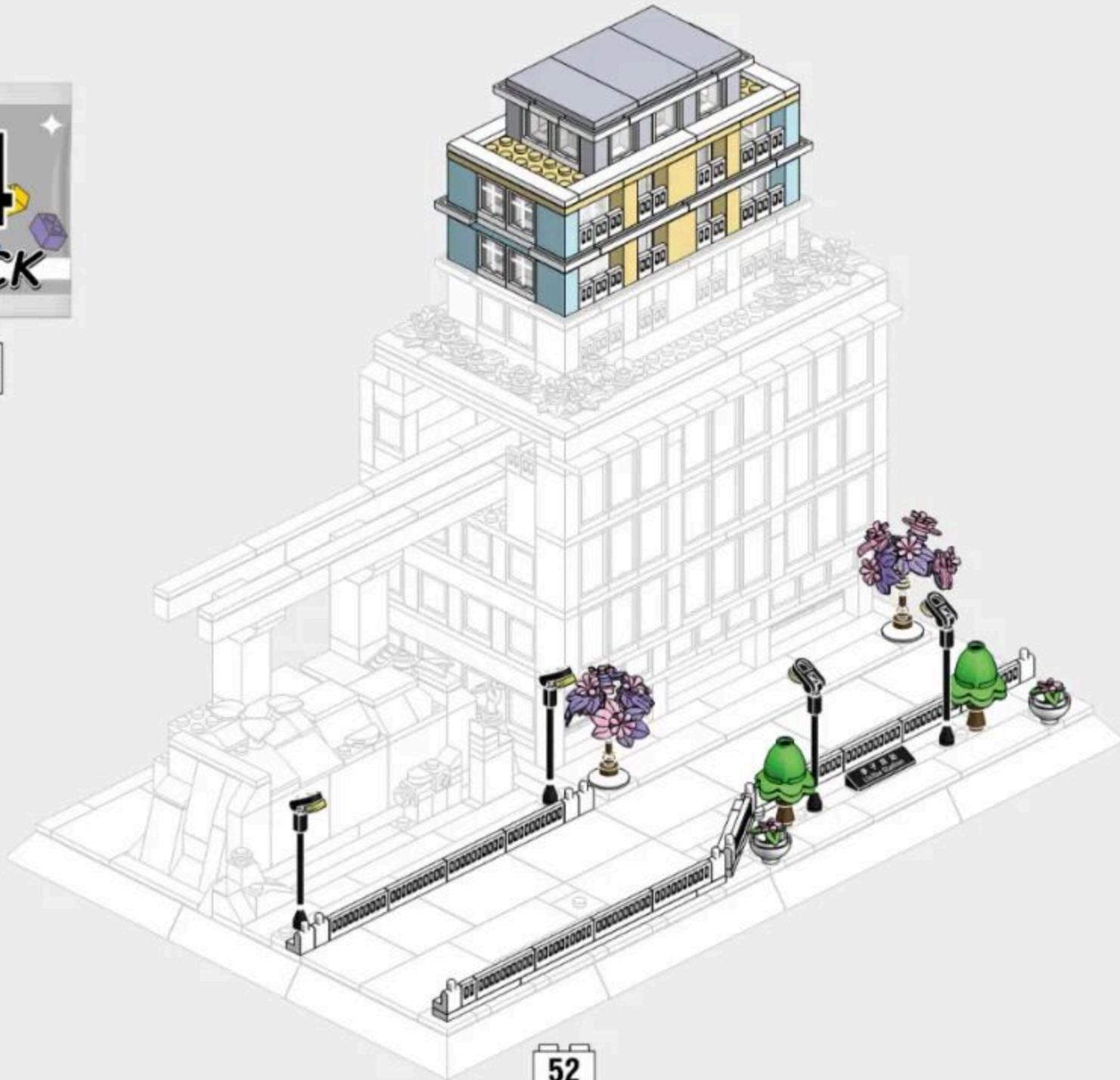

4-1

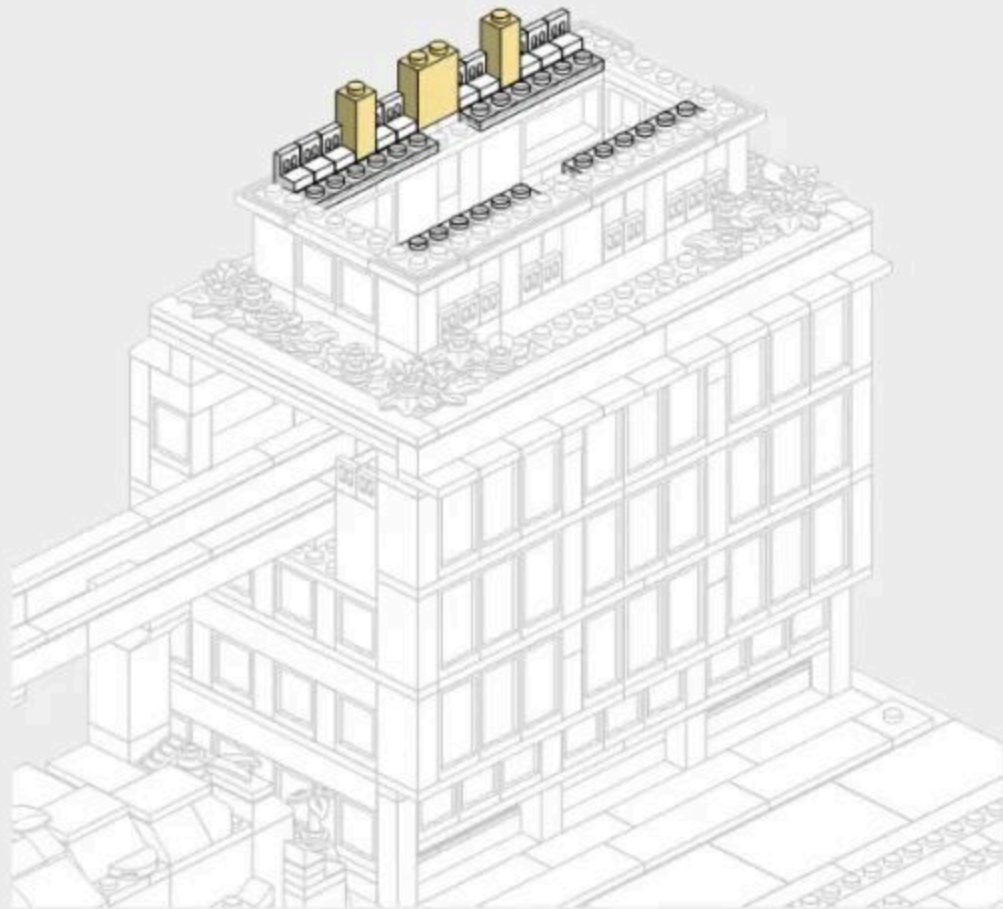

4-2

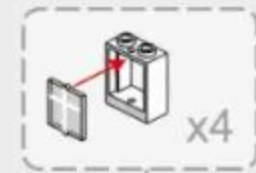

4-3



x1



x2



x10



4-4

2x8



x2

1x8



x2



x4

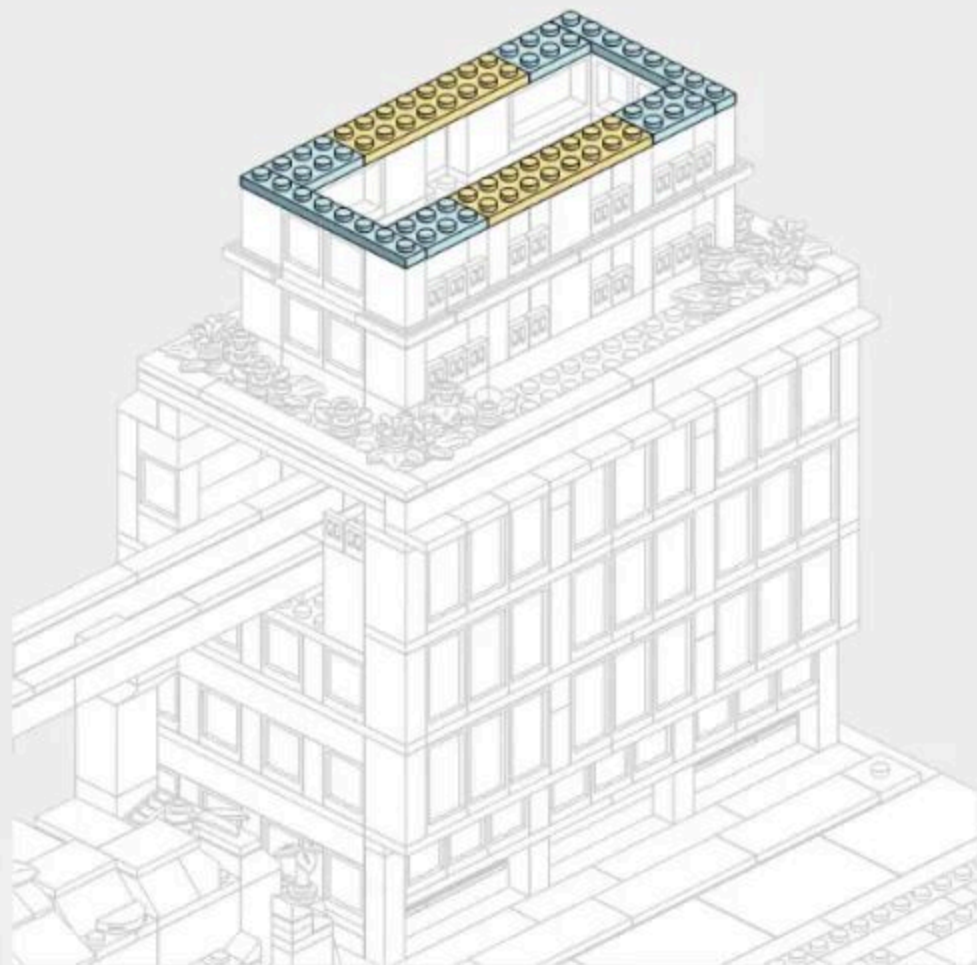

4-5

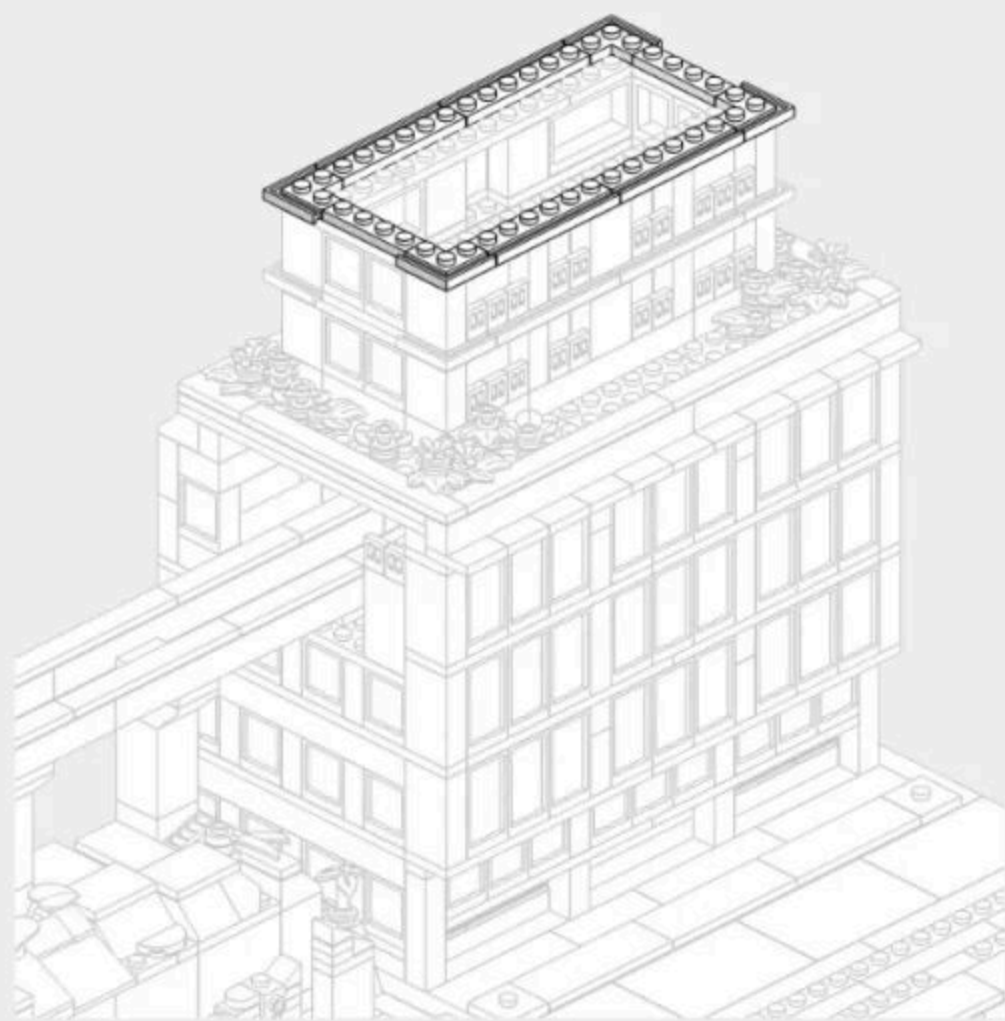
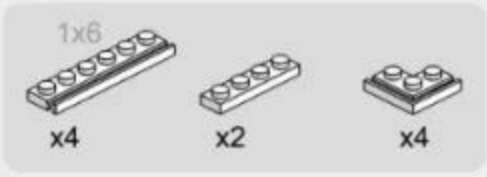

4-6

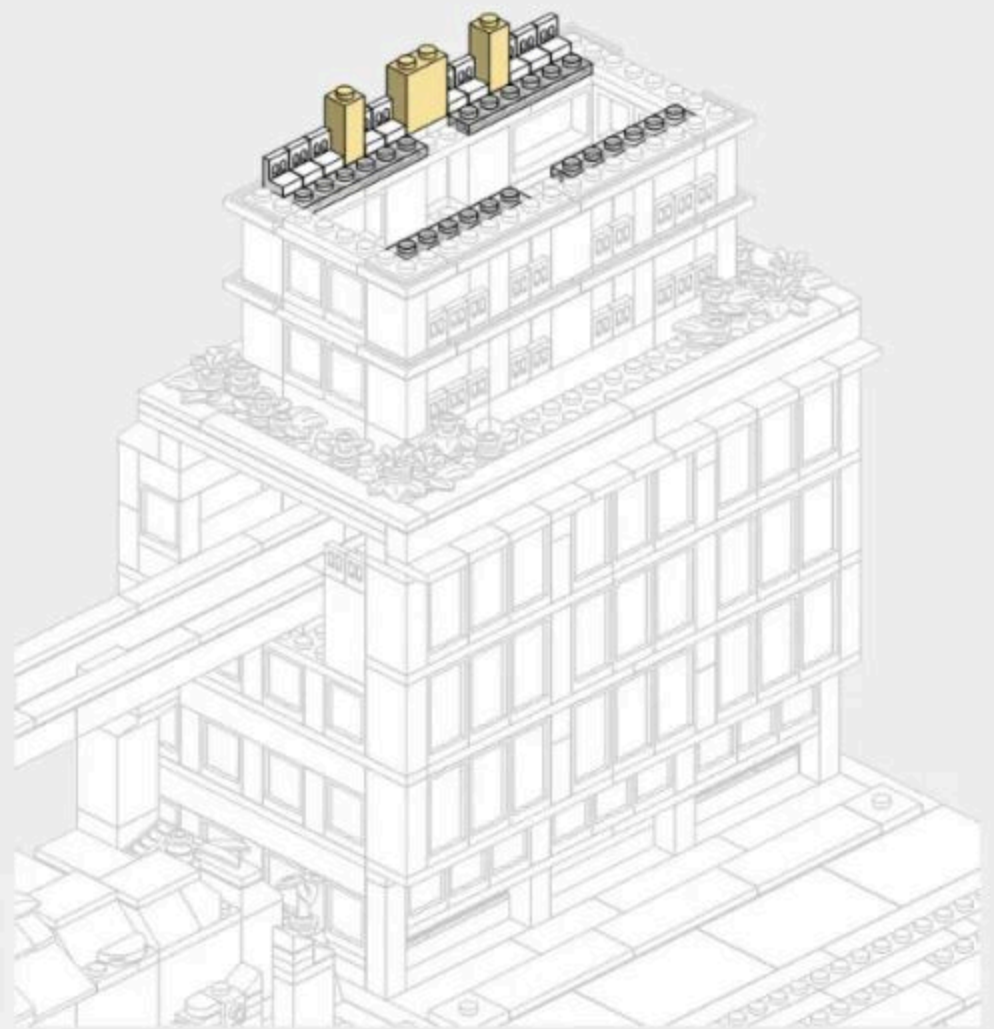

4-7



x4



x4



x4



x4



x4

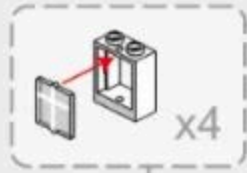

4-8



x1



x2



x10



4-9

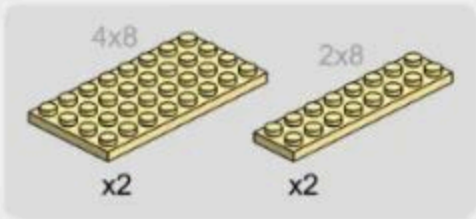

4-10

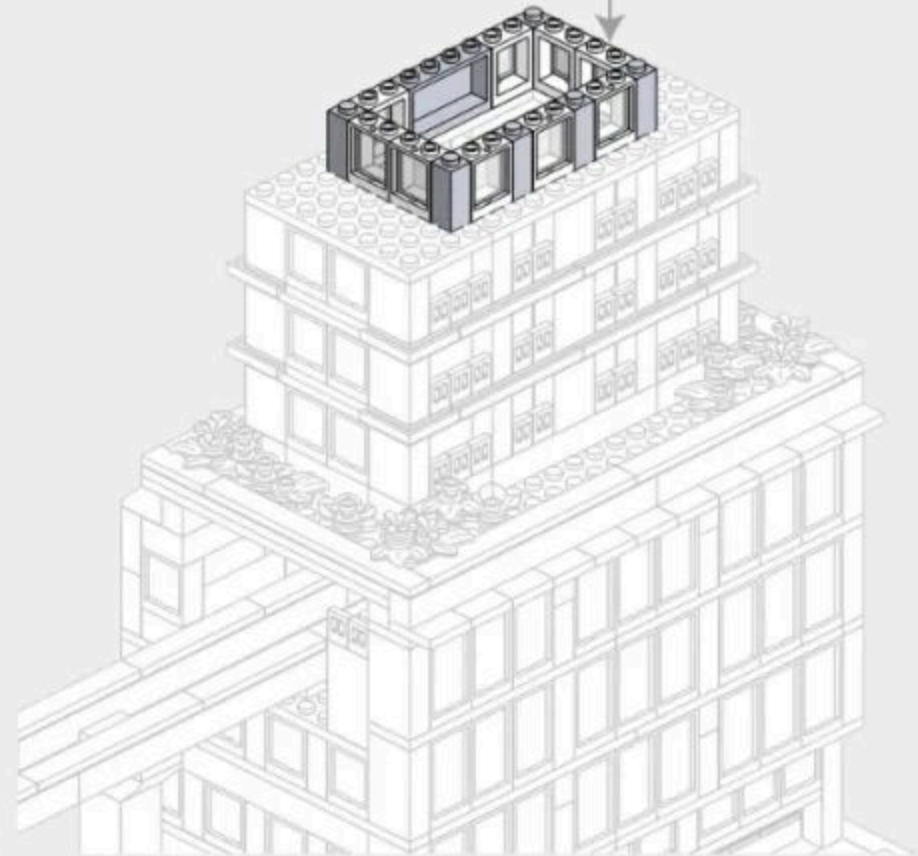
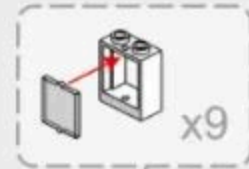

4-11

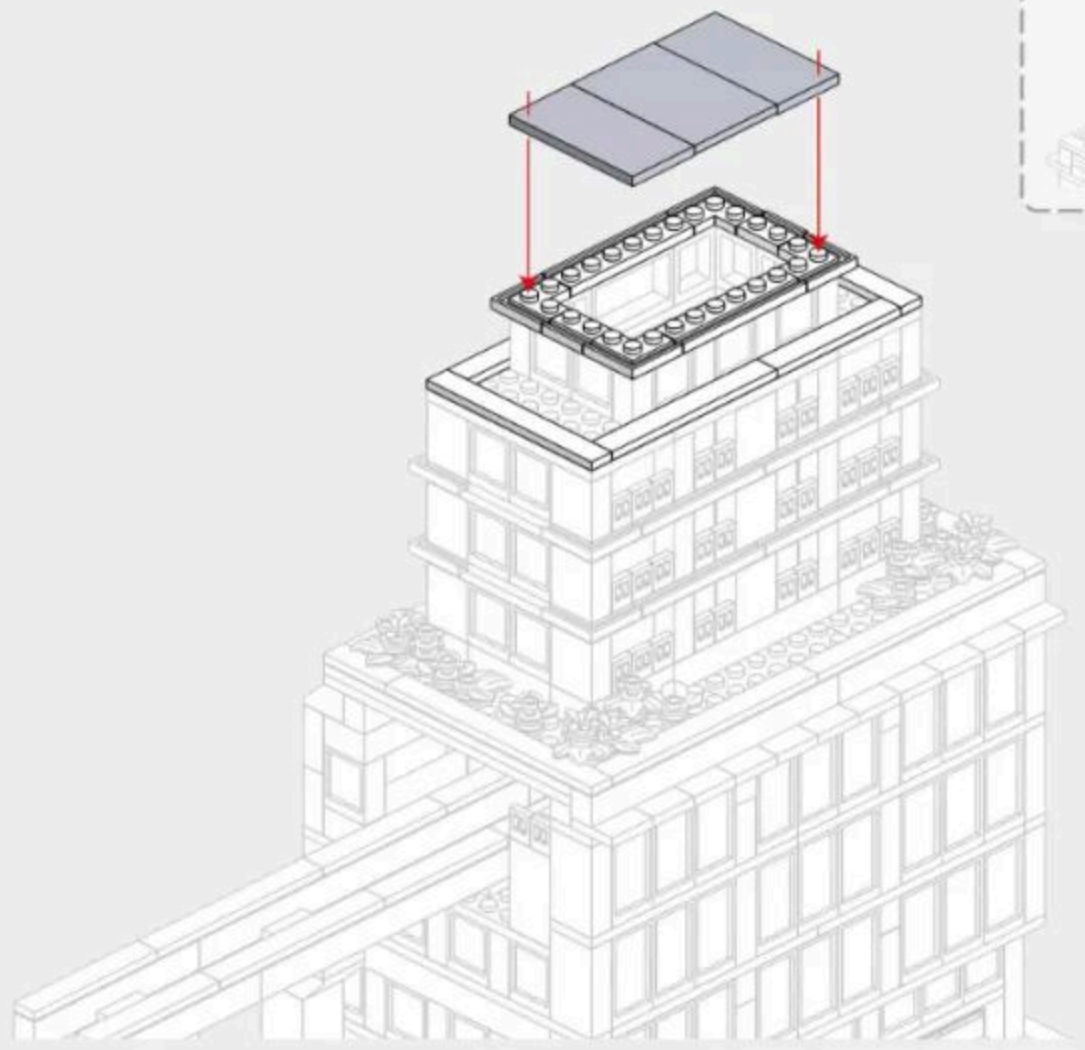
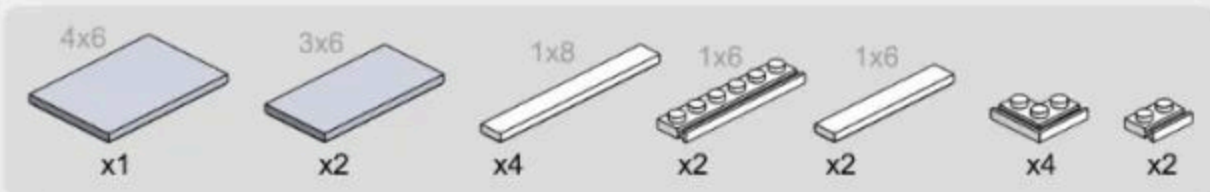

4-12

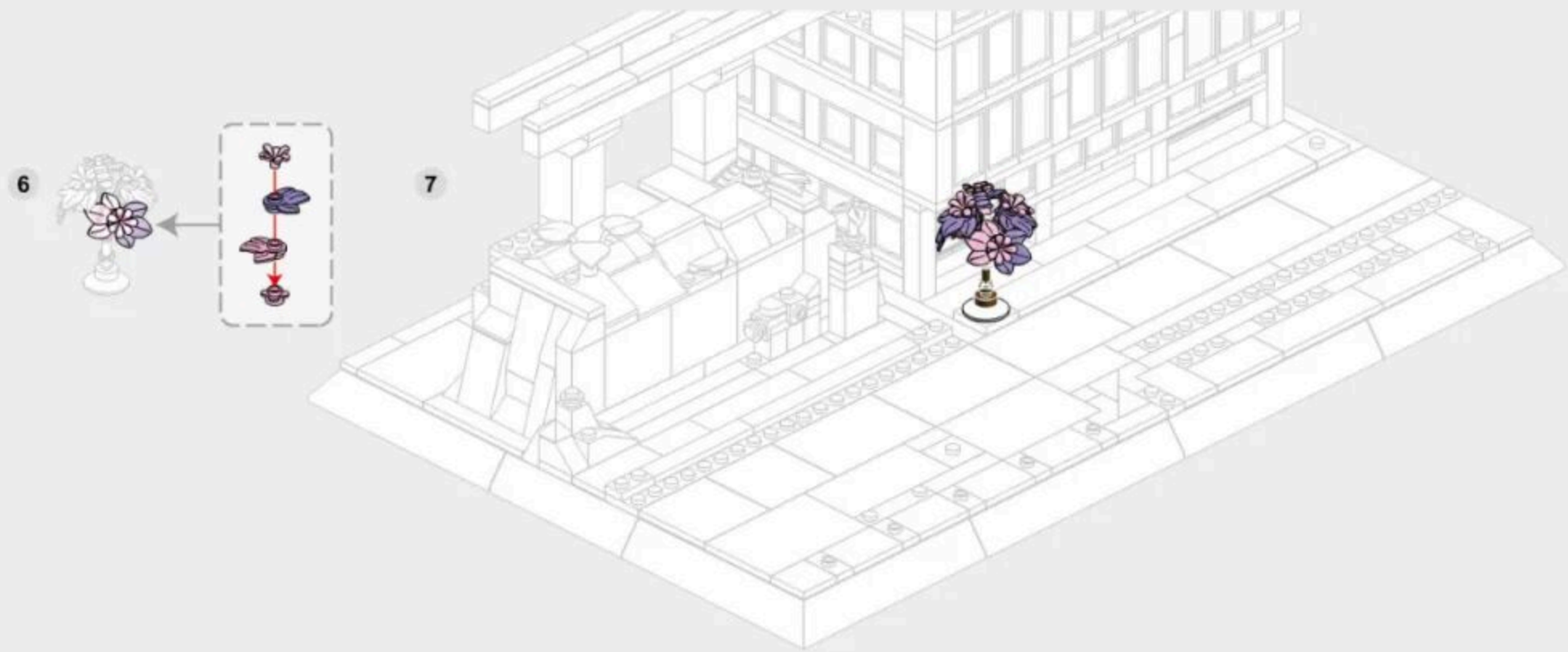

4-13

-  x1
-  x1
-  x1
-  x4
-  x3
-  x5
-  x1
-  x5
-  x1
-  x1

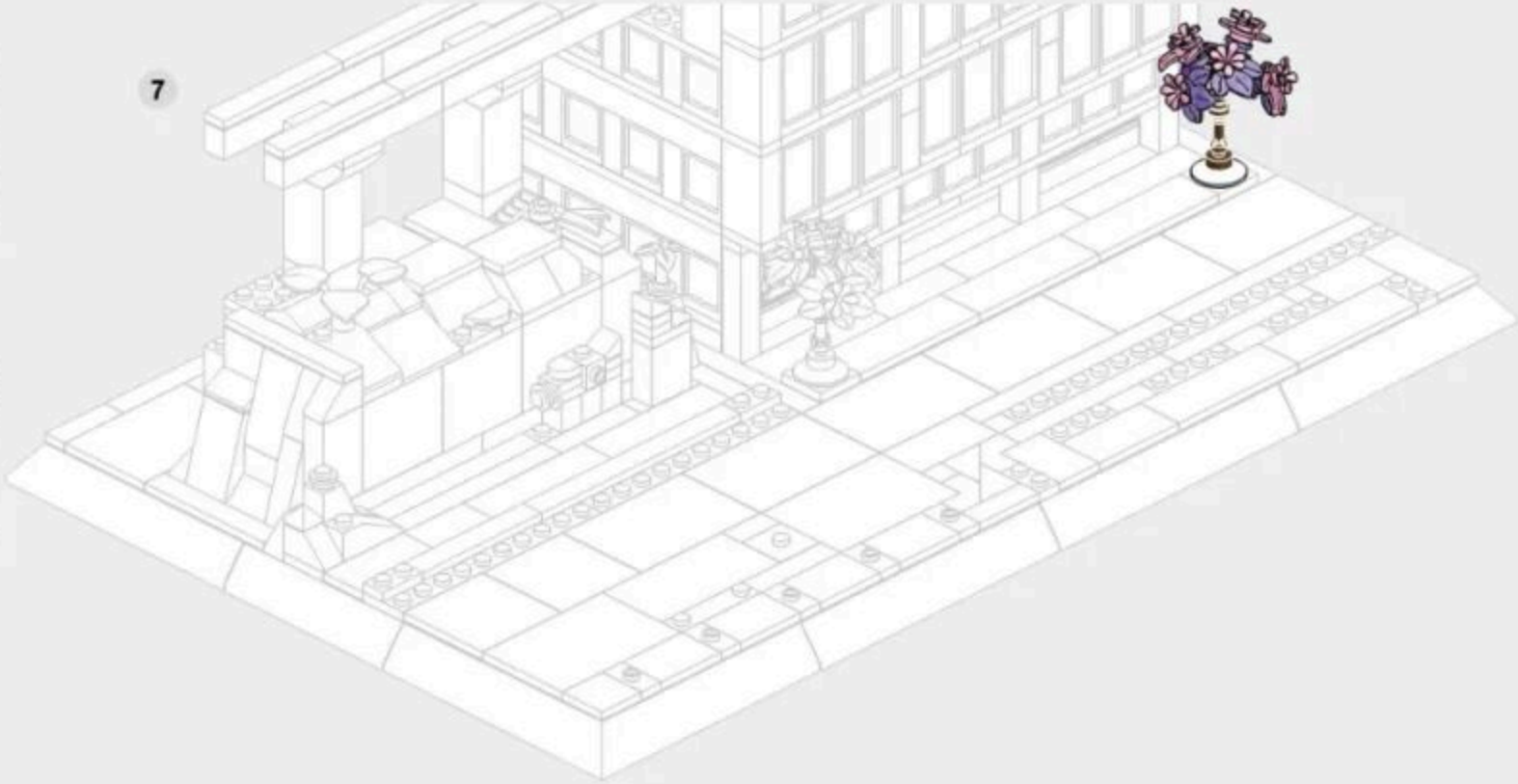
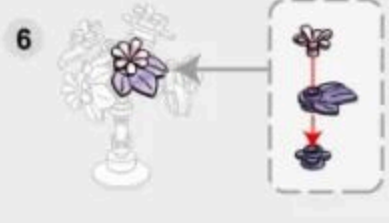
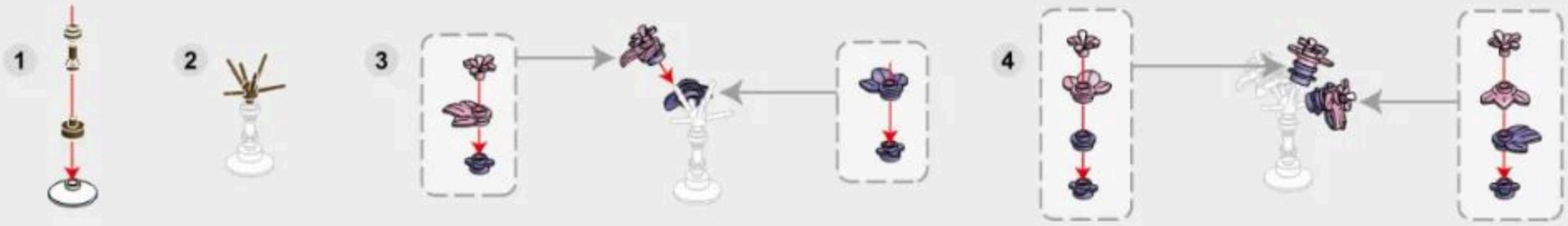

4-14

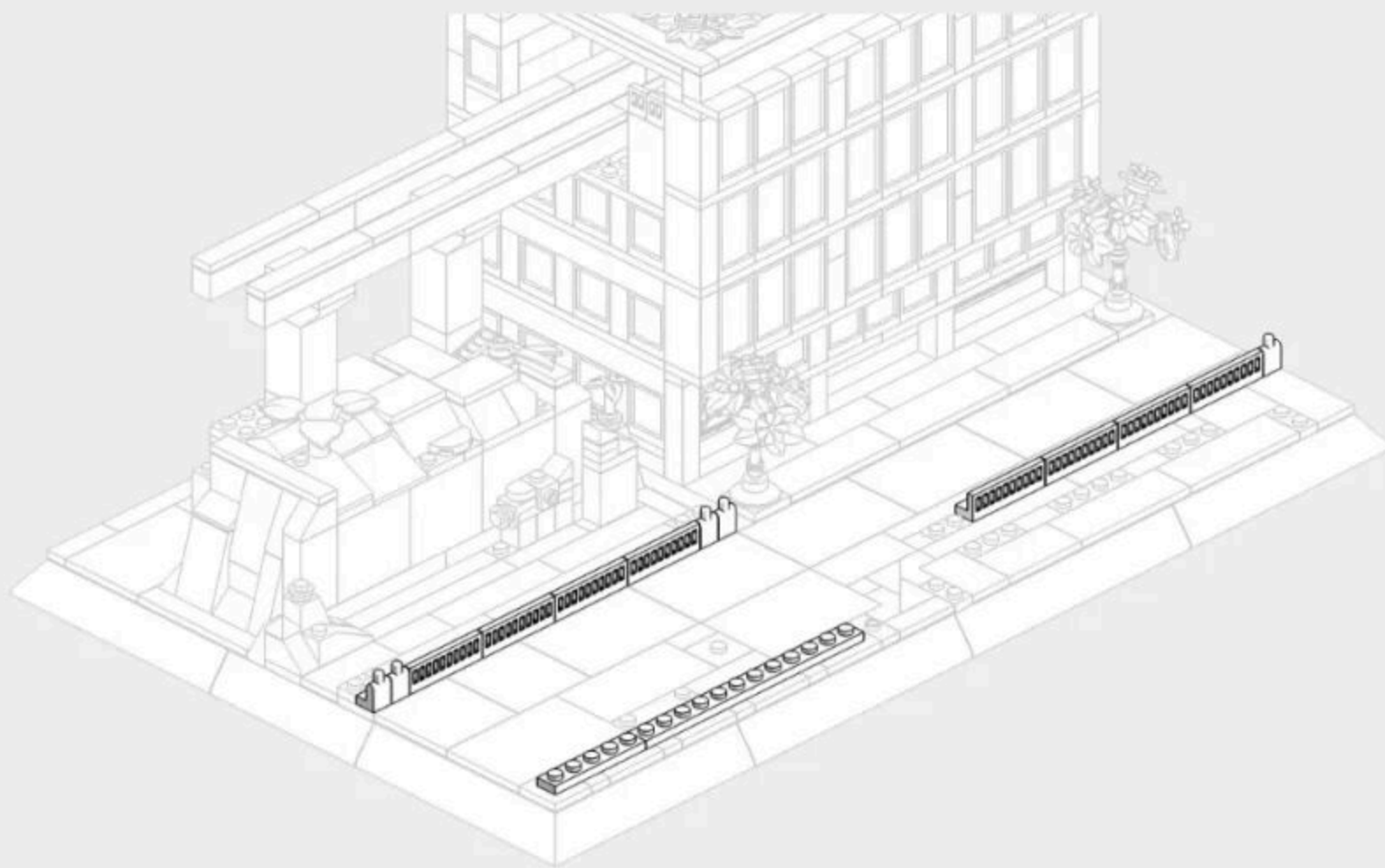

4-15

-  x5
-  x6
-  x1
-  x2
-  x2
-  x1

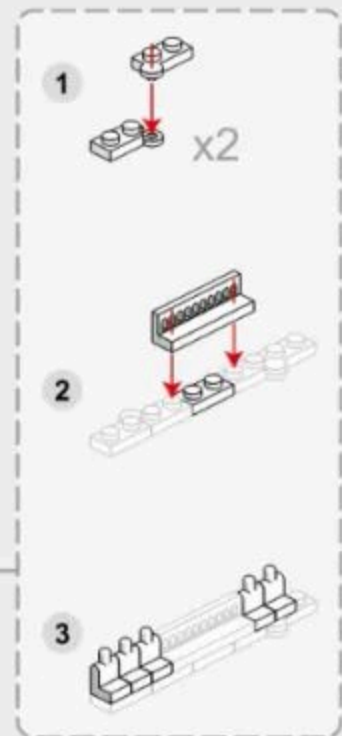
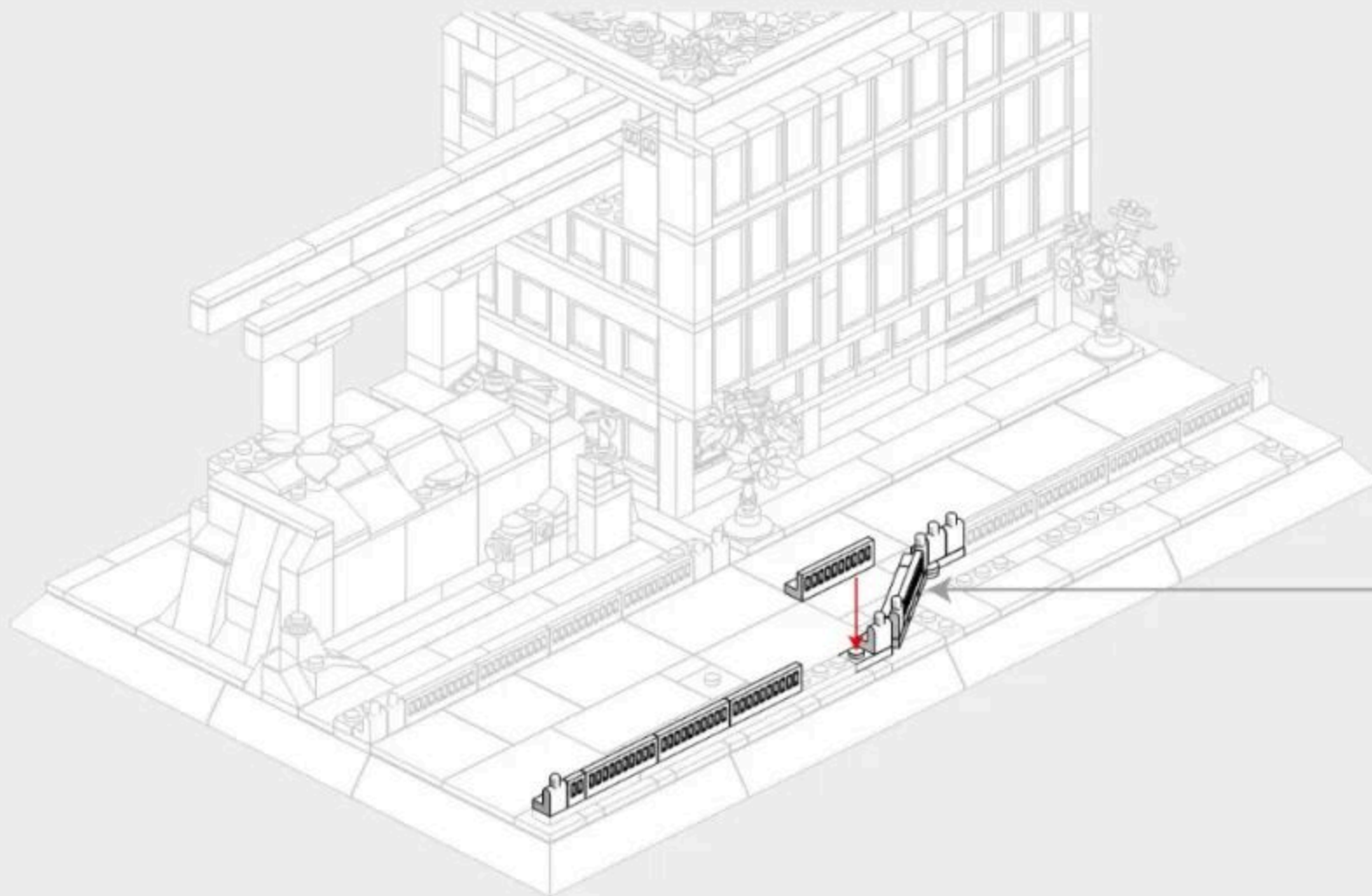

4-16



4-17

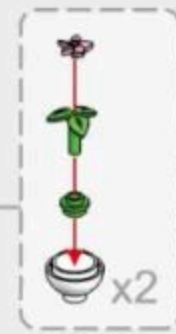
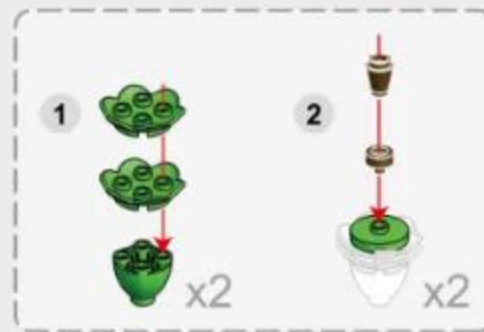





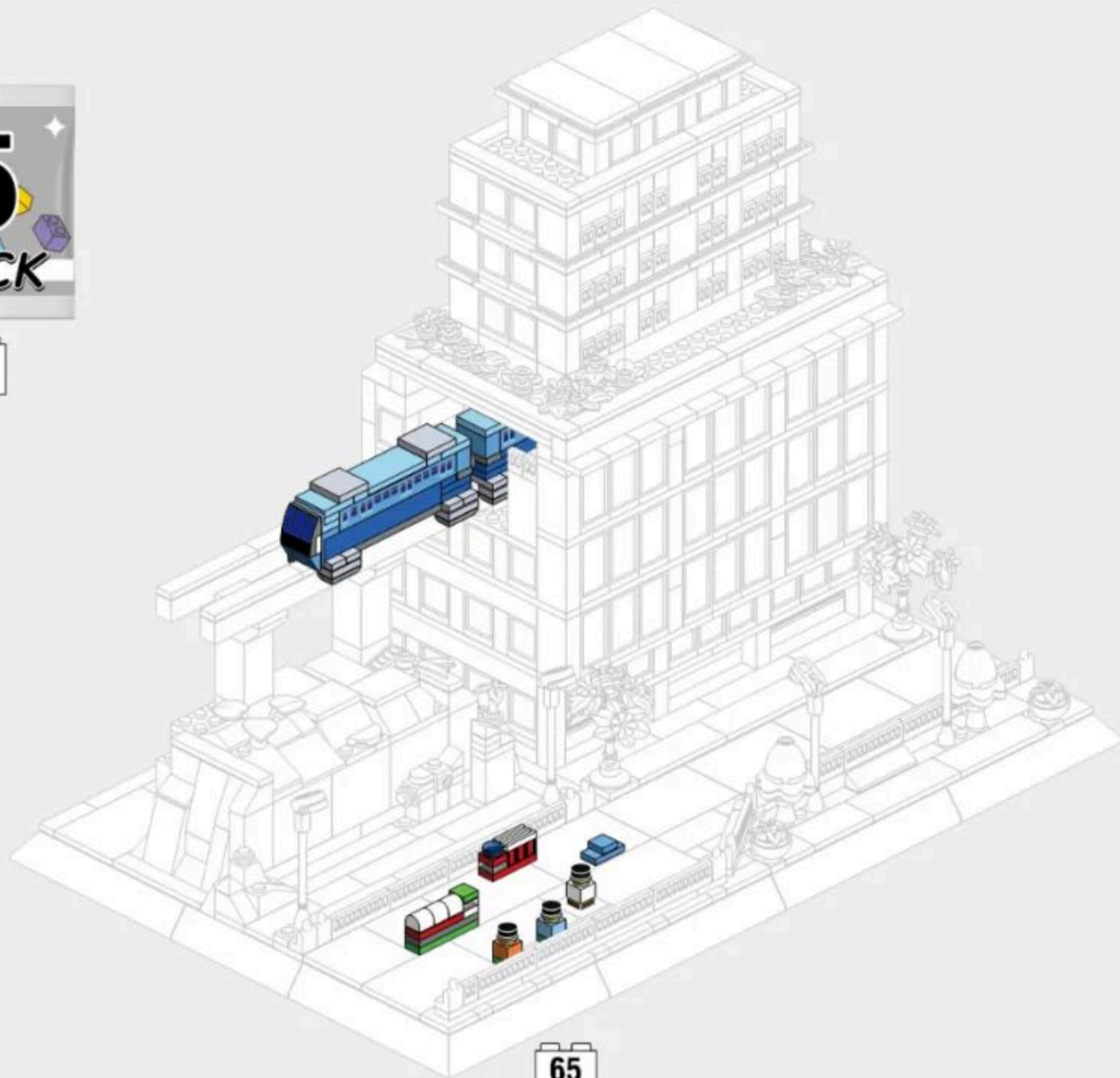



95PCS



65

5-1

-  x1
-  x1
-  x1
-  x1
-  x1
-  x1
-  x3
-  x3

Vertical View of Installation Drawing
安装图顶面

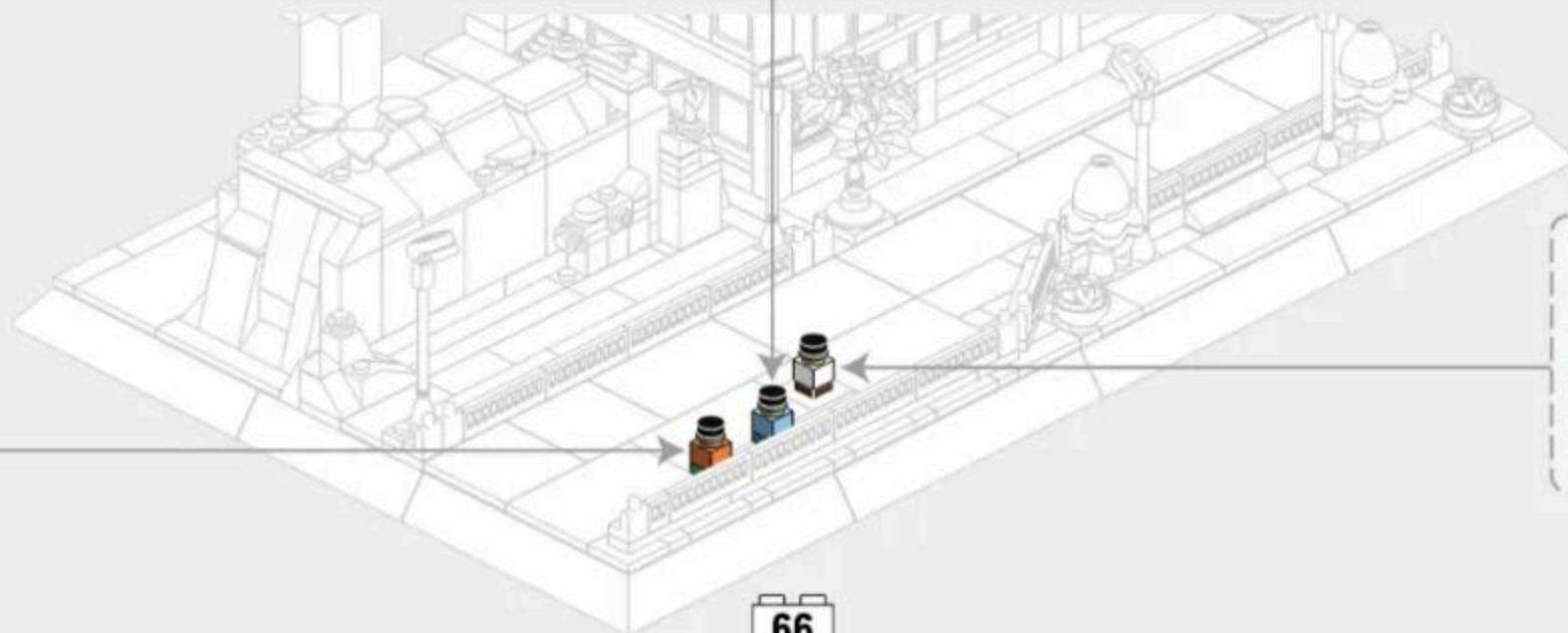
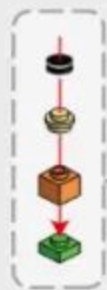
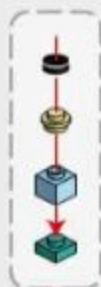
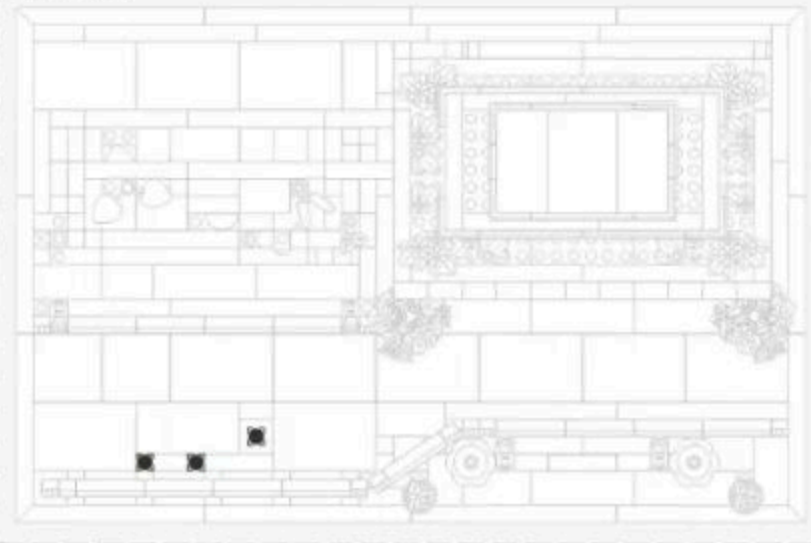

5-2

- x1
- x1
- x2
- x1
- x1
- x1
- x3
- x1
- x1
- x2
- x1
- x1
- x1

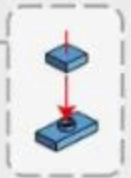
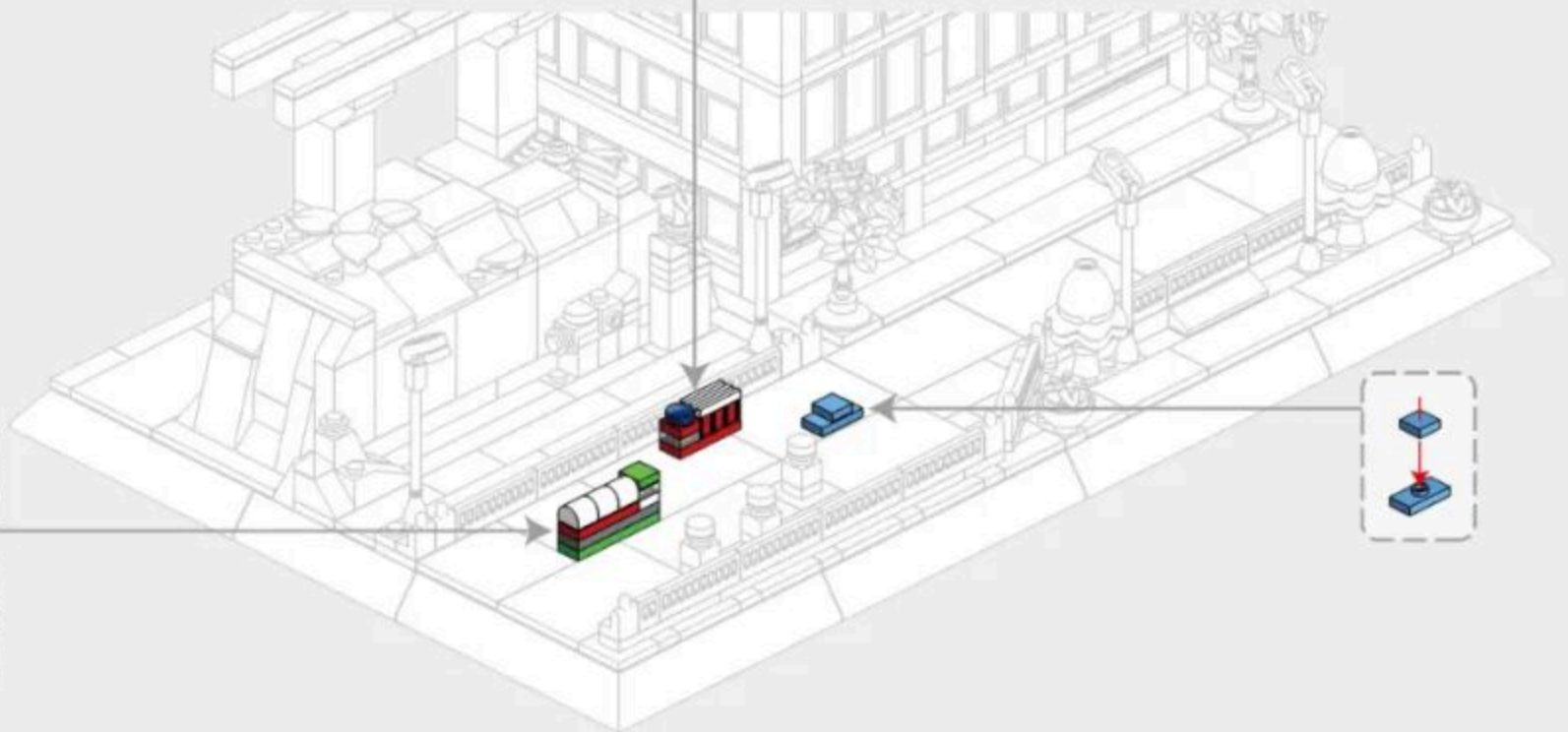
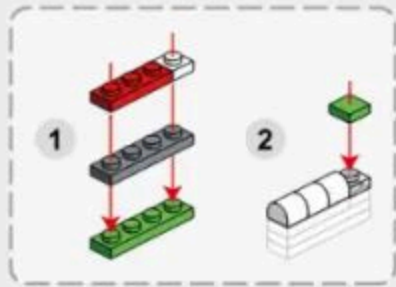
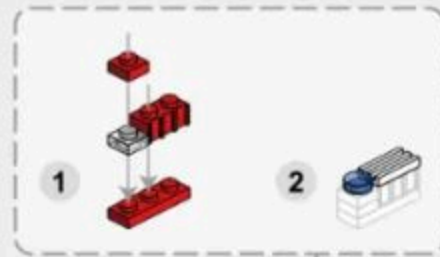

5-3

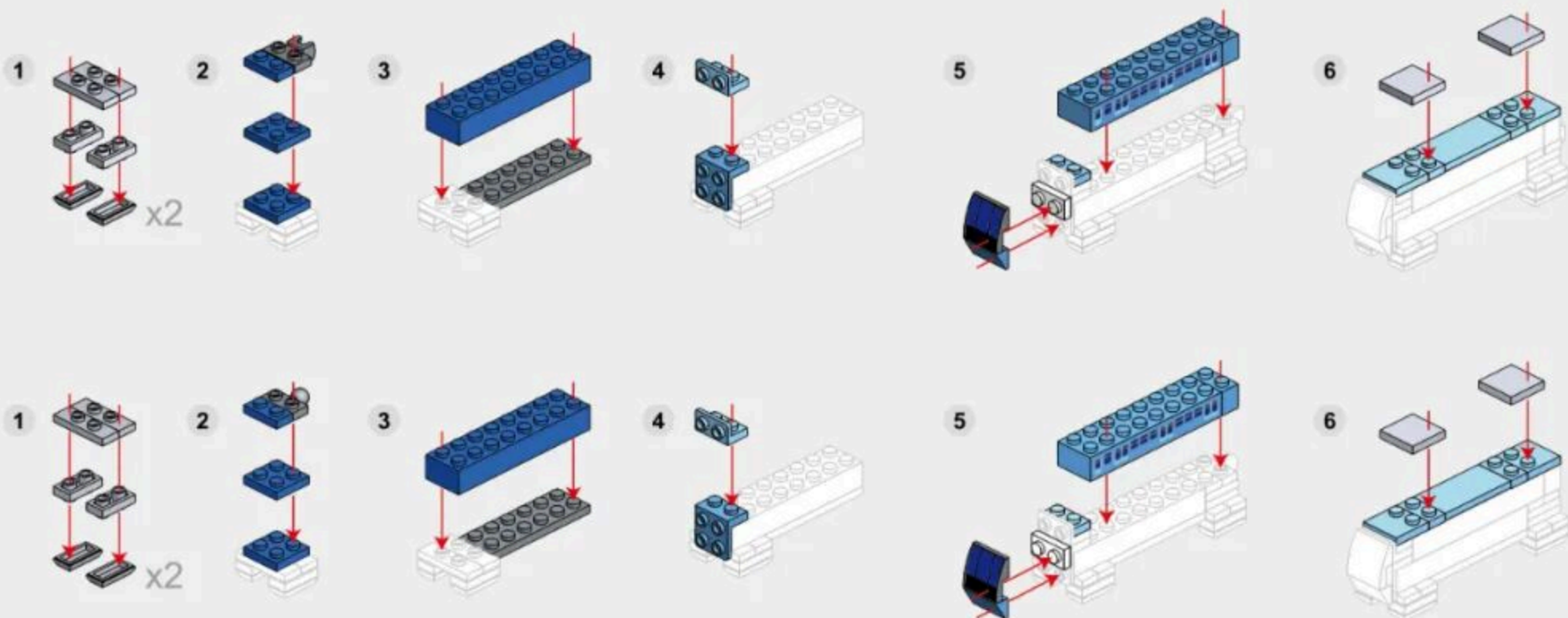

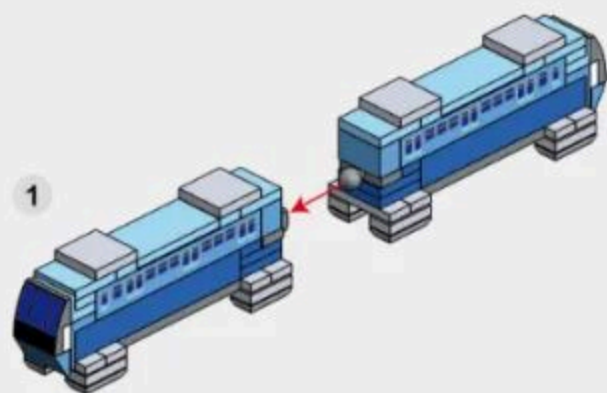

5-2

2

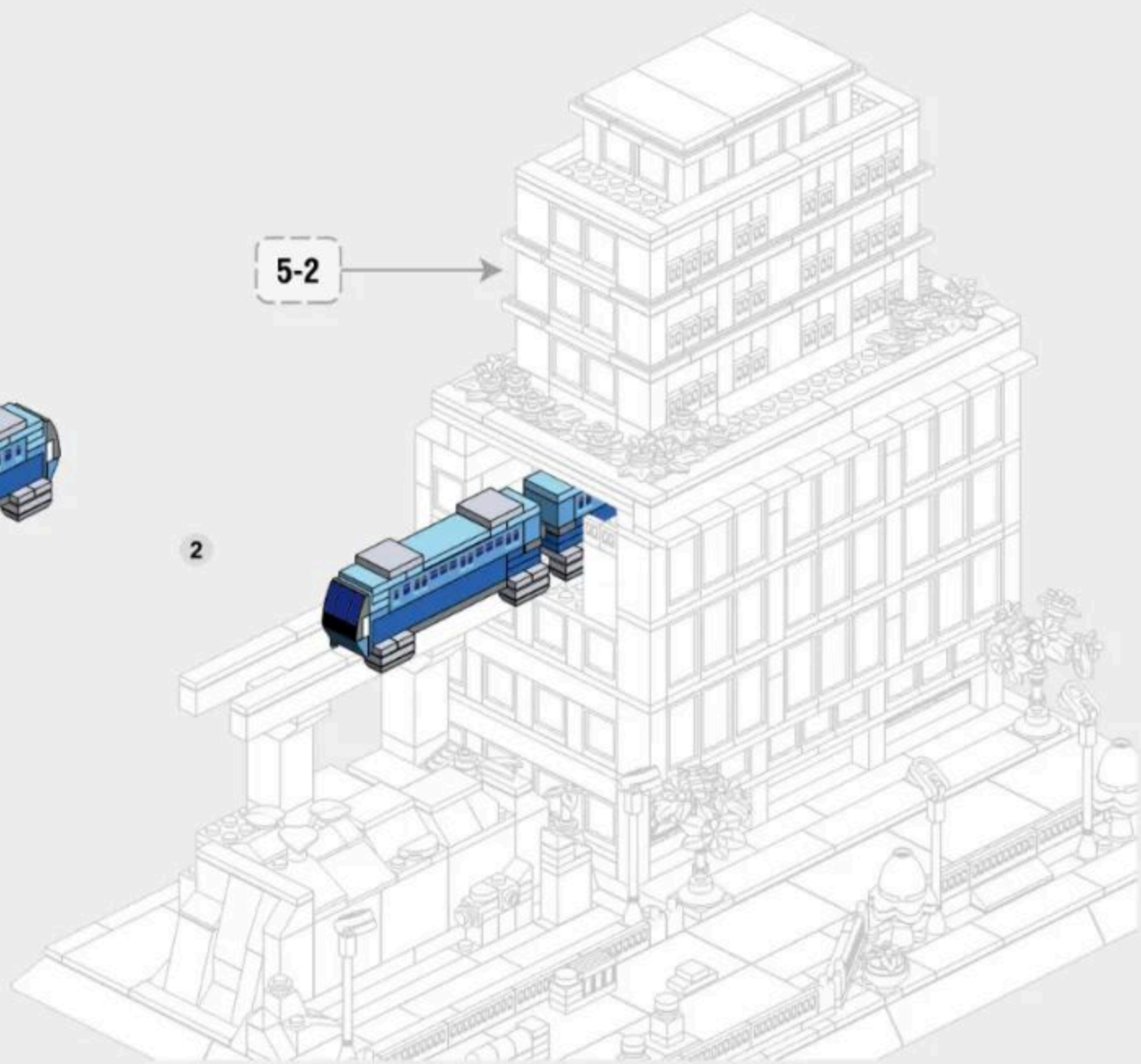



扫一扫
了解产品更多信息



ARCHITECTURE

The World's great architecture



Shaping Skills



Imagination & Curiosity



Mathematical



Self Discovery & Perception



Parent-Child Interaction



Problem Solving



Creativity



6224 英国伦敦白金汉宫
BUCKINGHAM PALACE-LONDON,ENGLAND



5225 意大利罗马斗兽场
COLOSSEUM-ROME,ITALY



5226 日本东京帝国饭店
IMPERIAL HOTEL-TOKYO,JAPAN



5227 美国纽约自由女神像
STATUE OF LIBERTY-NEW YORK,AMERICA



6211 德国柏林勃兰登堡门
BRANDENBURG GATE-BERLIN, GERMANY



6222 中国甘肃长城-嘉峪关
JIAYU PASS-GANSU, CHINA



6212 日本京都清水寺仁王门
NIMON GATE OF KITOMIZI-DERAI-TOTO,JAPAN



6213 俄罗斯莫斯科瓦西里大教堂
SAINT BASIL'S CATHEDRAL-MOSCOW,RUSSIA



6214 中国武汉黄鹤楼
YELLOW CRANE TOWER-WUHAN,CHINA



6215 英国伦敦眼
LONDON EYE-LONDON,ENGLAND



6221 中国北京故宫-太和殿
HALL OF SUPREME HARMONY-BEIJING,CHINA



6220 沙特阿拉伯麦加大清真寺
GREAT MOSQUE OF MECCA-SAUDI ARABIA



6219 美国纽约联合国大厦
UNITED NATIONS HEADQUARTERS-NEW YORK,AMERICA



4214 美国华盛顿白宫
WHITE HOUSE-WASHINGTON D.C.,AMERICA



4212 意大利罗马许愿池
TREVI FOUNTAIN-ROME,ITALY



4213 法国巴黎卢浮宫
MUSEE DU LOUVRE-PARIS,FRANCE



4218 新加坡-鱼尾狮
MERLION,SINGAPORE



4219 英国伦敦双子塔桥
TOWER BRIDGE-LONDON,ENGLAND



4216 美国华盛顿林肯纪念馆
LINCOLN MEMORIAL-WASHINGTON D.C.,AMERICA



4217 新加坡-金沙酒店
MARINA BAY SANDS,SINGAPORE



4210 埃及开罗吉萨金字塔
GREAT PYRAMID OF GIZA-CAIRO,EGYPT



4221 加拿大渥太华国会山庄
PARLIAMENT BUILDING-OTTAWA,CANADA



4211 英国伦敦伊丽莎白塔
ELIZABETH TOWER-ENGLAND



4215 加拿大多伦多电视塔
THE CN TOWER-CANADA



4220 美国纽约熨斗大厦
FLATIRON BUILDING-NEW YORK,AMERICA



4222 阿联酋哈利法塔
THE BURJ KHALIFA TOWER-DUBAI, U.A.E.



5224 中国上海东方明珠广播电视塔
ORIENTAL PEARL TOWER-SHANGHAI, CHINA



5212 美国纽约帝国大厦
EMPIRE STATE BLDG.-NEW YORK, AMERICA



5213 马来西亚吉隆坡石油双塔
PETRONAS TWIN TOWERS-KUALUMPUR, MALAYSIA



5214 意大利托斯卡纳比萨斜塔
LEANING TOWER OF PISA-TUSCANY, ITALY



5216 英国伦敦伊丽莎白塔
ELIZABETH TOWER-LONDON, ENGLAND



5219 俄罗斯莫斯科斯帕斯科塔
SPASSKAYA TOWER-MOSCOW, RUSSIA



5220 阿联酋迪拜阿拉伯塔酒店
BURJ AL ARAB HOTEL-DUBAI, U.A.E.

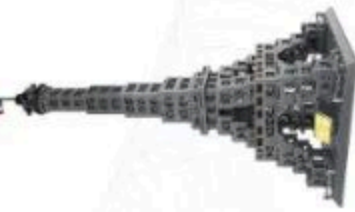

5217 法国巴黎埃菲尔铁塔
EIFFEL TOWER-PARIS, FRANCE



5221 中国台北101大楼
TAIPEI 101-TAIPEI, CHINA



5228 美国芝加哥威利斯大厦
WILLIS TOWER-CHICAGO, AMERICA



5231 巴西里约热内卢救世基督像
CRISTO REDENTOR-RIO DE JANEIRO, BRASIL



6223 中国武汉长江大桥
WUHAN YANGTZE RIVER BRIDGE



5210 法国巴黎圣母院大教堂
CATHEDRALE NOTRE DAME DE PARIS-PARIS, FRANCE



5211 印度阿格拉泰姬陵
TAJ MAHAL-AGRA, INDIA



5223 法国巴黎凯旋门
ARC DE TRIOMPHE-PARIS, FRANCE



5215 英国伦敦双子塔桥
TOWER BRIDGE-LONDON, ENGLAND



5222 中国北京天坛祈年殿
HALL OF PRAYER FOR GOOD HARVESTS-BEIJING, CHINA



6210 美国旧金山金门大桥
GOLDEN GATE BRIDGE-SAN FRANCISCO, AMERICA



6216 中国北京万里长城（八达岭）
THE GREAT WALL-BEIJING, CHINA



5218 中国北京天安门
TIANANMEN TOWER-BEIJING, CHINA



6217 中国西藏布达拉宫
POTALA PALACE-TIBET, CHINA



6218 芬兰罗瓦涅米圣诞老人办公室
SANTA CLAUS OFFICE-ROVANIEMI, FINLAND



6225 墨西哥库库尔坎玛雅金字塔
EL CASTILLO-KULKULKAN, MEXICO



6226 德国巴伐利亚新天鹅堡
SCHLOSS NEUSCHWANSTEIN-BAVARIA, GERMANY



5229 土耳其伊斯坦布尔少女塔
MAIDEN TOWER-ISTANBUL, TURKEY



5230 中国昆明南长街爱莲亭
AWANTING PAVILION-KUNMING, CHINA



7210 中国上海世博会中国馆
CHINA PAVILION AT EXPO-SHANGHAI/CHINA



5232 美国宾夕法尼亚州流水别墅
FALLING WATER-PENNSYLVANIA, AMERICA



5233 美国芝加哥范斯沃斯住宅
FARNSWORTH HOUSE-CHICAGO, AMERICA



5234 美国华盛顿唐人街
CHINA TOWN-WASHINGTON, D.C., AMERICA



3210 美国纽约自由女神像
STATUE OF LIBERTY-NEW YORK, AMERICA



4223 中国北京清华园
TSINGHUA CAMPUS-BEIJING, CHINA



7211 中国湖南岳阳楼
YUEYANG TOWER-HUNAN, CHINA



8210 澳大利亚悉尼歌剧院
SYDNEY OPERA HOUSE-BENNELONG POINT, AUSTRALIA



7212 中国江南吕蒙王阁
PAVILION OF PRINCE TENG-JIANGSU, CHINA



6227 中国河南郑州嵩山少林寺
SHAOLIN TEMPLE-HENAN, CHINA



5213 中国重庆洪崖洞
HONGKONG-CHONGQING, CHINA



5235 美国华盛顿国会大厦
UNITED STATES CAPITOL-WASHINGTON, D.C., AMERICA



5236 中国安徽潜州醉翁亭
ZHENFENG PAVILION-ANHUI, CHINA



6228 中国陕西西安钟楼
YAN BELL TOWER-SHAANXI, CHINA



5238 美国西雅图太空针塔
SPACE NEEDLE-SEATTLE, AMERICA



5237 法国巴黎萨伏伊别墅
VILLA SAVOYE-PARIS, FRANCE



6229 中国山西运城鹳雀楼
STORK TOWER-SHANXI, CHINA



6230 希腊爱琴海圣托里尼岛
SANTORINI-PIRA, GREECE



6231 中国上海海关大楼
SHANGHAI CUSTOMS HOUSE-SHANGHAI, CHINA



5239 中国北京紫禁城角楼
TOWER OF PALACE MUSEUM-BEIJING, CHINA



5240 韩国首尔崇礼门
NAMDANGJU TEMPLE-SEOUL, KOREA



5241 中国江苏南京夫子庙
CONFUCIUS TEMPLE-JIANGSU, CHINA



5242 美国纽约古根海姆博物馆
GUGGENHEIM MUSEUM-NEW YORK, AMERICA



6232 中国江苏秦淮河画舫
QINHUAI RIVER PAINTED BOAT-JIANGSU, CHINA



6233 法国圣米歇尔山
SAINT MICHAELS MOUNT-NORMANDY, FRANCE



6234 中国河南洛阳栾川老君山
THE LAOJUN MOUNTAIN-HENAN, CHINA



5243 耶路撒冷岩石圆顶
DOME OF THE ROCK-JERUSALEM



6235 中国江苏苏州寒山寺 (普明宝塔)
HANSHAN TEMPLE-JIANGSU, CHINA



4224 英国威尔特郡巨石阵
STONEHENGE-WILTSHIRE, ENGLAND



4225 中国内蒙古自治区蒙古包
MONGOLIAN YURT-INNER MONGOLIA, CHINA



8211 中国福建土楼(承启楼)
CHENGQI EARTH BUILDING-FUJIAN, CHINA



4226 沙特阿拉伯麦加大清真寺(克尔白)
KERBAL GREAT MOSQUE OF MECCA, SAUDI ARABIA

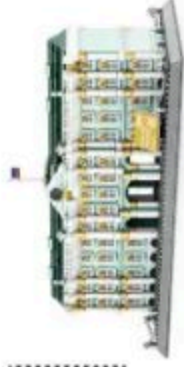

5244 俄罗斯圣彼得堡冬宫
WINTER PALACE-ST.PETERSBURG, RUSSIA



7214 中国陕西西安鼓楼
MIAN DRUM TOWER-SHAANXI, CHINA



5245 中国重庆李子坝站
LIZIBA STATION-CHONGQING, CHINA



LIZIBA STATION

COUNTRY: China

CITY: Chongqing

