



THE SAINT BASIL'S CATHEDRAL

OF MOSCOW СОБОР ВАСИЛИЯ БЛАЖЕННОГО

Russia
The world's great architecture

Ages
6+



NO.6213
1373 PCS

Perseverance

积木匠心. 颗粒匠者



The White House



The Burj Al-Arab Hotel



The Leaning Tower Of Pisa



The Spasskaya Tower



The Taj Mahal



The CN Tower



The Eiffel Tower



The Temple of Heaven



The Golden Gate Bridge



The Brandenburg Gate



The Triumphal Arch



The Big Ben

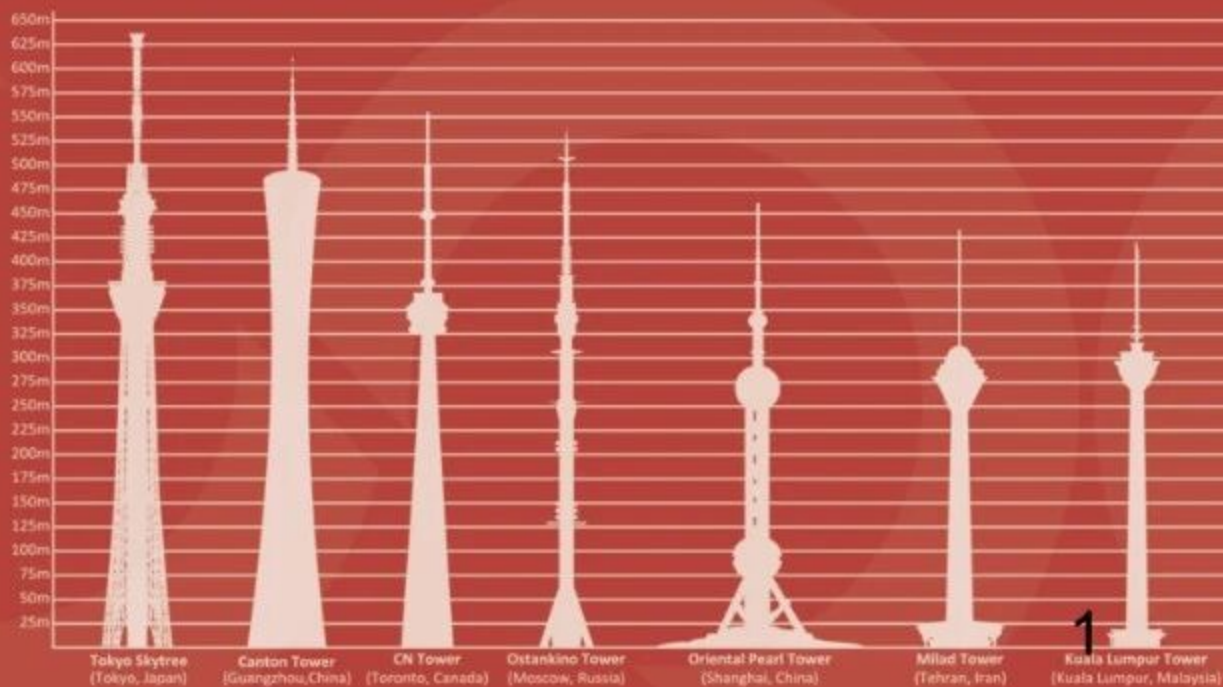

It will be a city...

这将构成一座城市...

Architecture



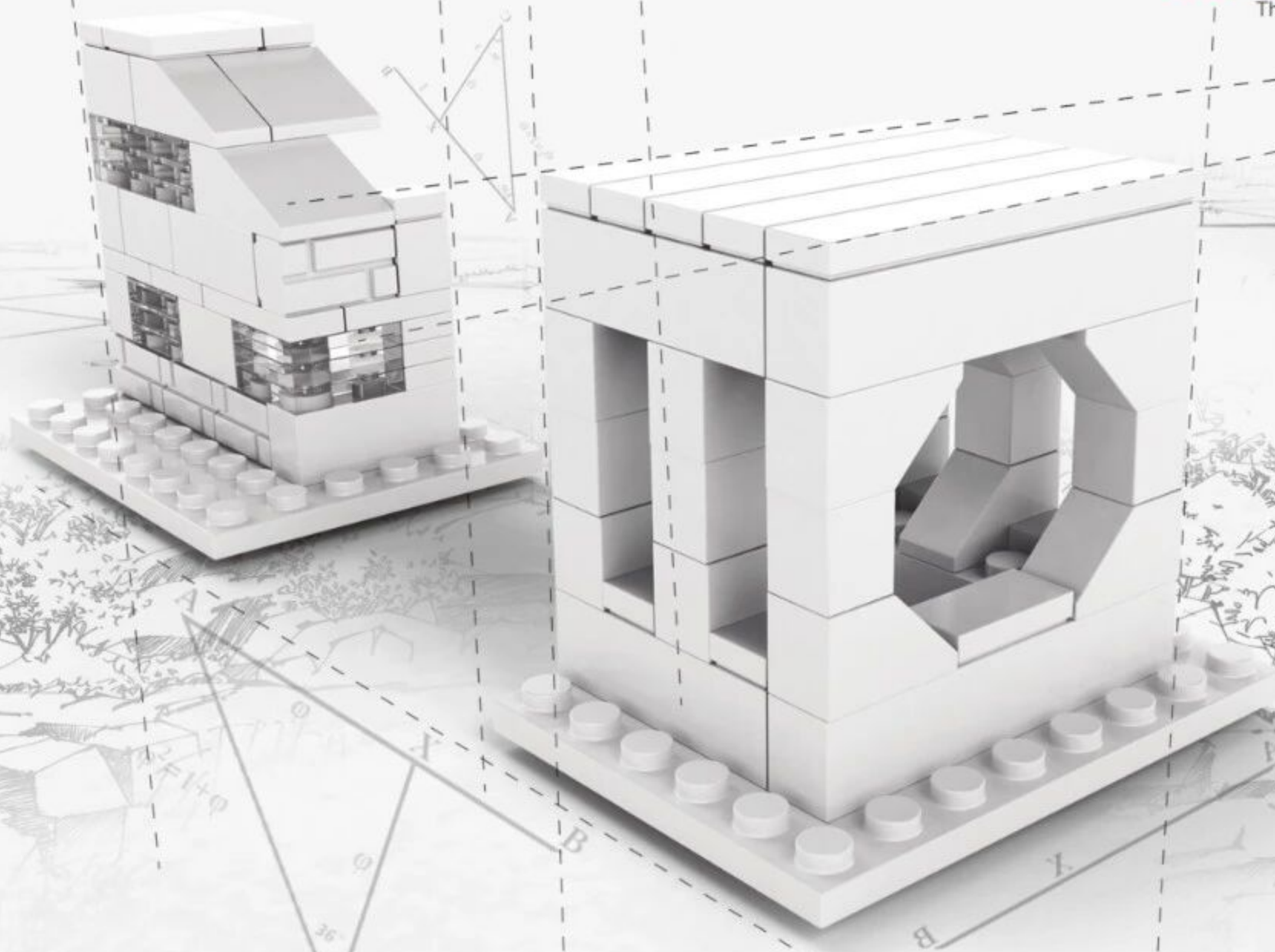

proportion

对产品精确分析运用3维技术最大限度还原实物比例

Accurate analysis of the product, using 3D technology to maximize the reduction of physical objects.

Structure

剖析结构与实物数据比例

Analyze the ratio of product structure to physical data

Anatomy

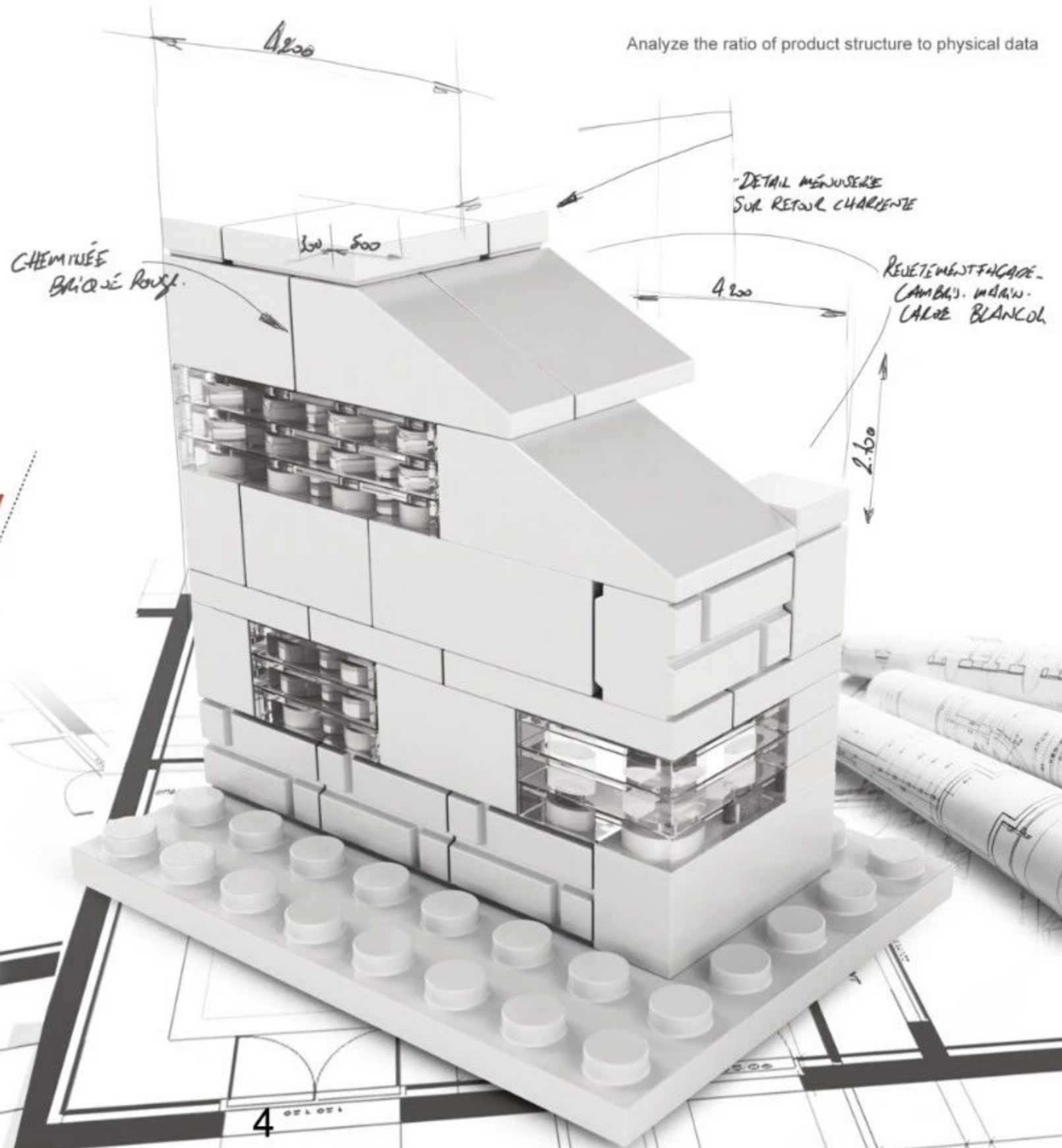

Creativity

外观设计结合黄金比例更好展现美感

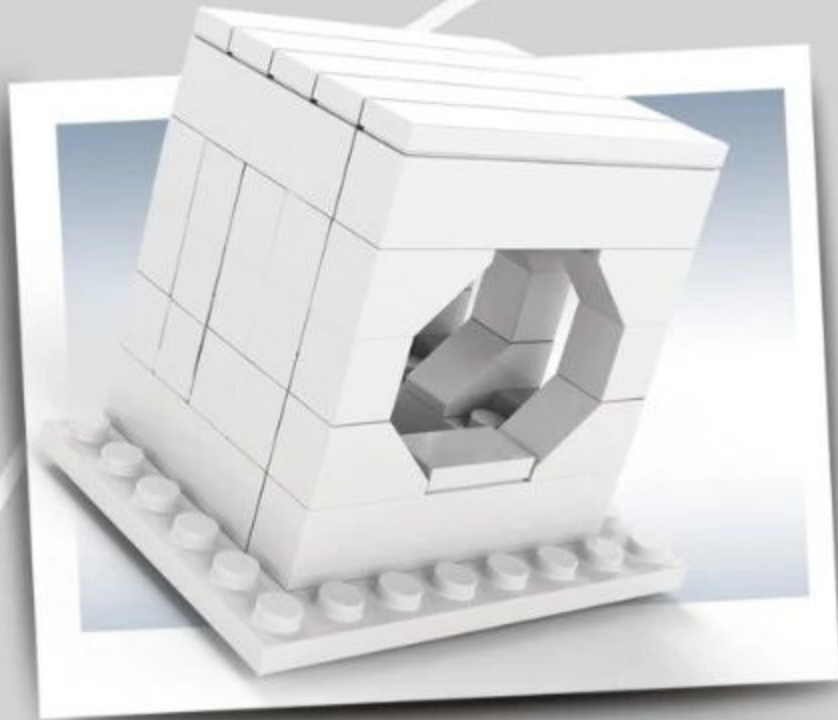

DETAIL MENUSÈRE
SUR RETOUR CHARENTE

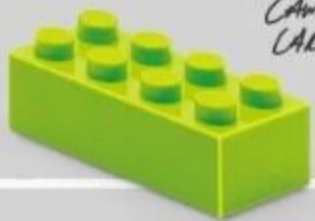

REVÊTEMENT FACÈDE -
CARRÉS. MARRON.
CARRÉS BLANCS.

$$\varphi = \frac{a+b}{a} = \frac{a}{b} = 1,61803398875$$

CHÈMINEE
Brique de Rouge.

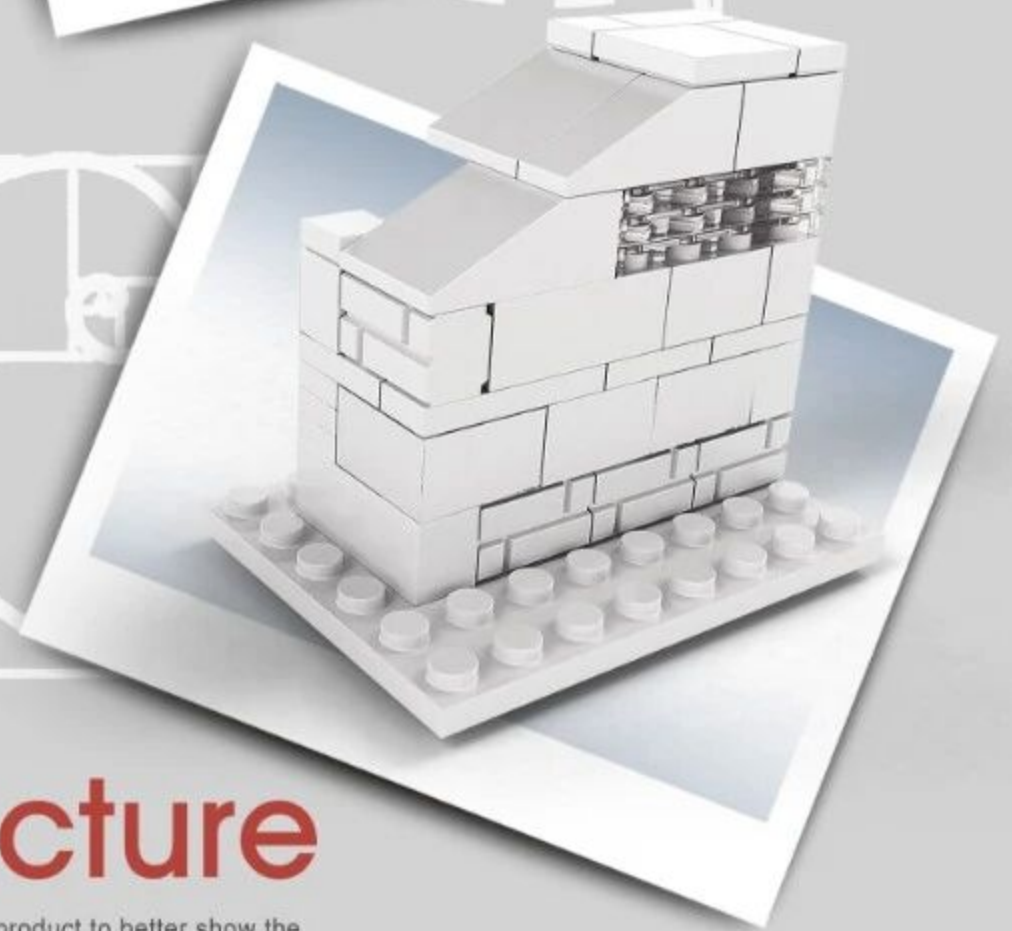

Architecture

Use the golden ratio in the design and development of the product to better show the beauty of the product.

Instructions For Use

Brickseparator

积木起件器使用说明

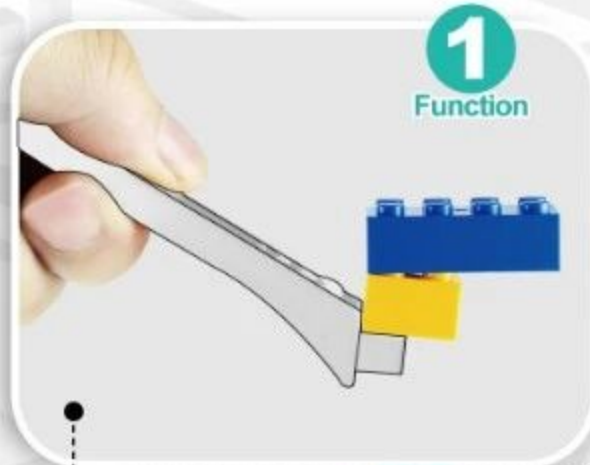

1
Function

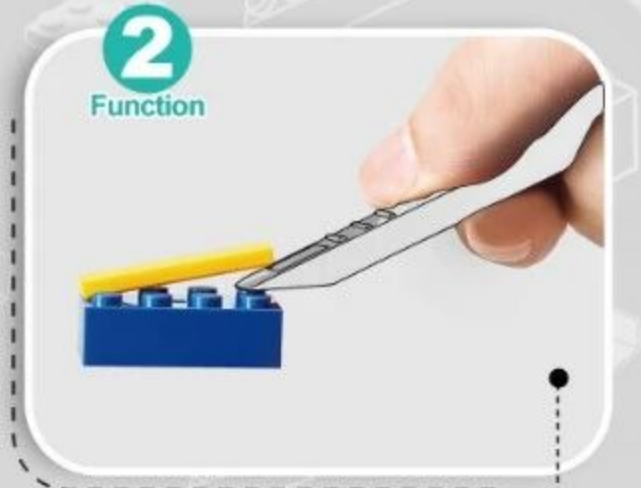

2
Function

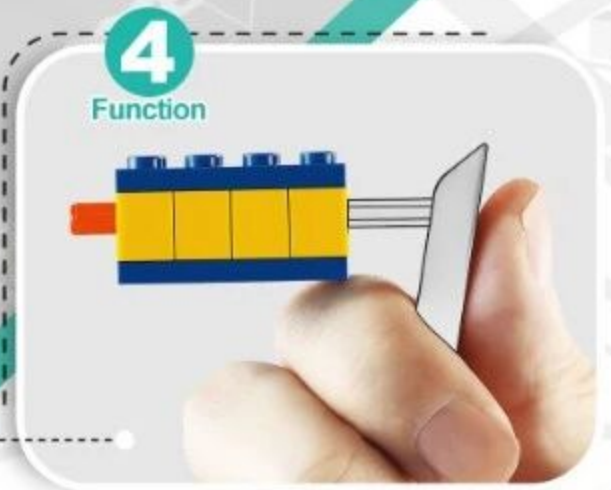

4
Function













3
Function

4 ways to make installation easier
让安装更简单



1:1 Physical Reference Table

十字棒配件1:1尺寸参照表

2	$(1 \times 2) = 2$	
3	$(1 \times 3) = 3$	
4	$(1 \times 4) = 4$	
5	$(1 \times 5) = 5$	
6	$(1 \times 6) = 6$	
7	$(1 \times 7) = 7$	
8	$(1 \times 8) = 8$	
9	$(1 \times 9) = 9$	
10	$(1 \times 10) = 10$	
12	$(1 \times 12) = 12$	
16	$(1 \times 16) = 16$	



1:1

Instructions For Use

让安装更简单



Building Blocks

拼装小技巧



1

- First open the product packaging according to the instructions.

按指导用正确方式拆解产品外包装。



2

- Summarize all parts to count the number of familiar accessories.

拆开积木包装对照说明书清单确认积木数量。



3

- Arranging all accessories by color helps to quickly install the product.

把确认好的积木以颜色进行分类排好以便安装。



4

- Carefully install the product and learn about building.

按说明书步骤拼装并完成你的积木模型。

INSTALLATION
. TIPS .

PARTS LIST 配件清单

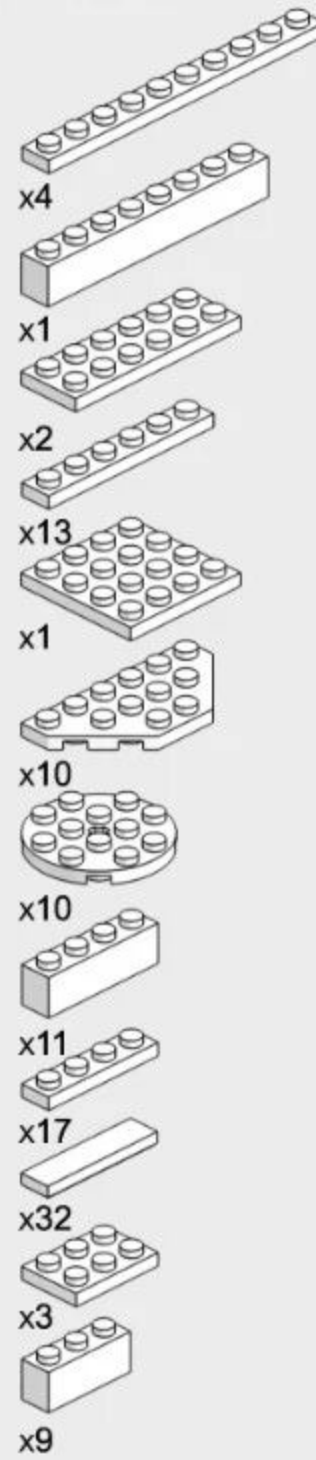
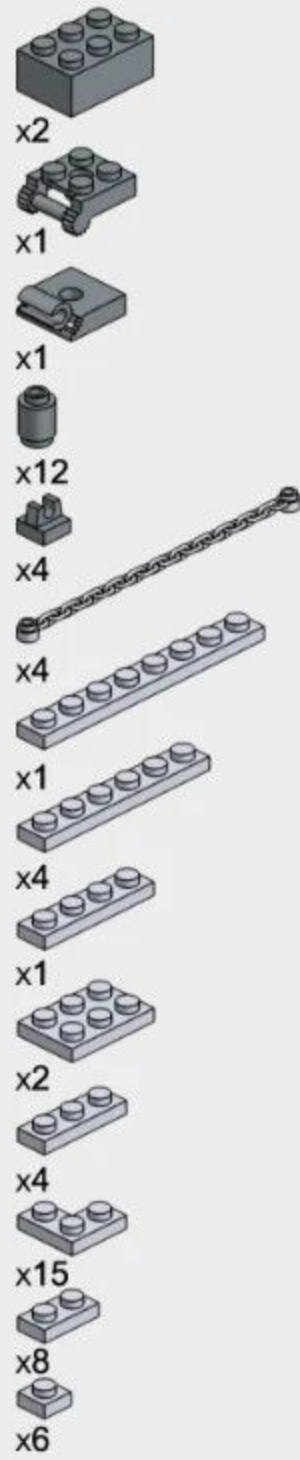
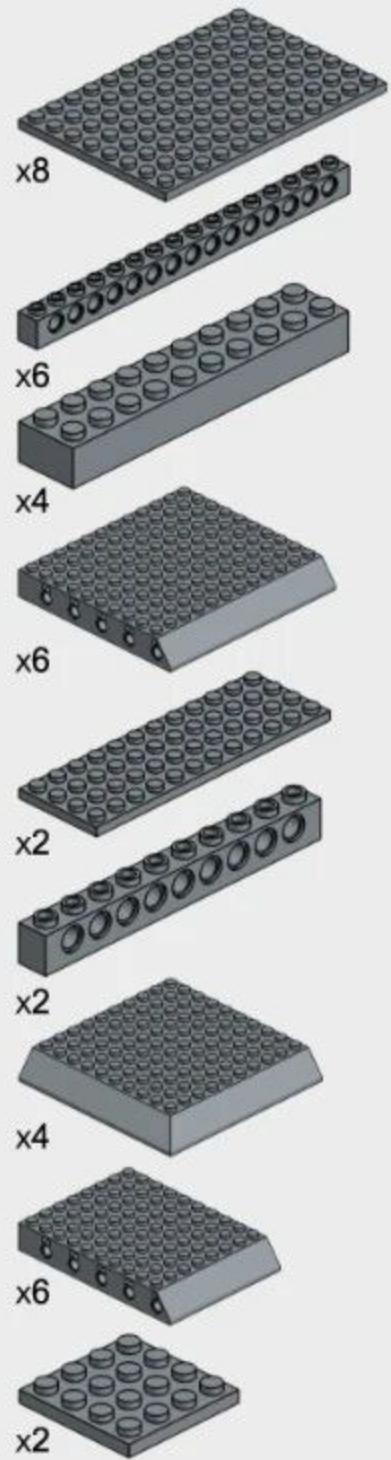

产品有增补件请以实物为准 Product has additional parts, please prevail in kind.

PARTS LIST 配件清单

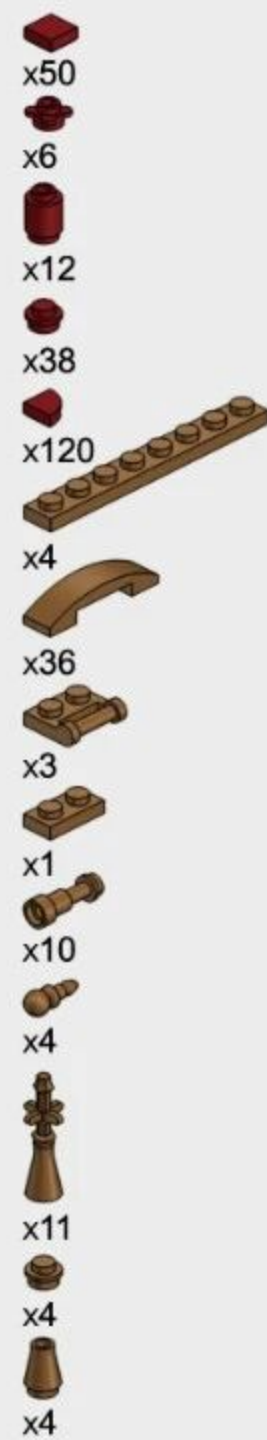
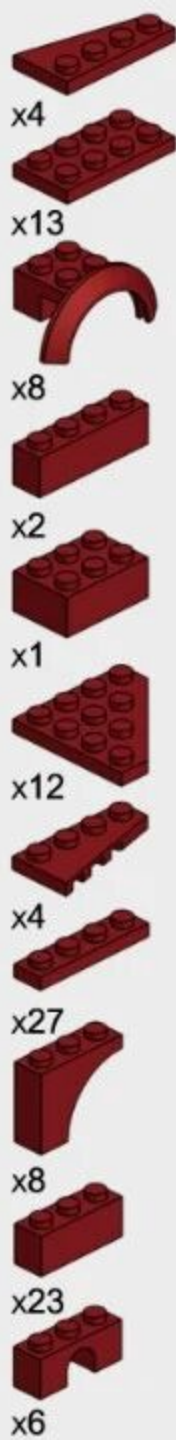
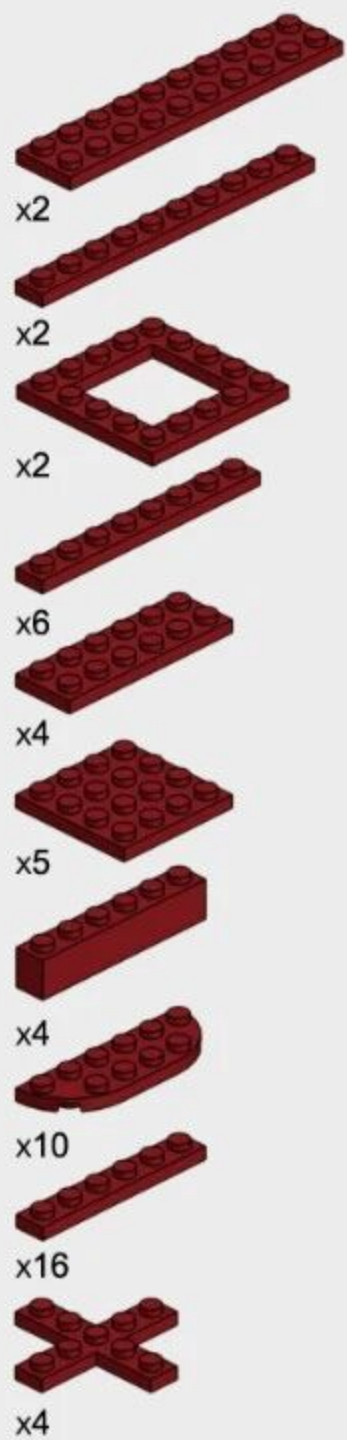

产品有增补件请以实物为准 Product has additional parts, please prevail in kind.

The Saint Basil's Cathedral
Russia

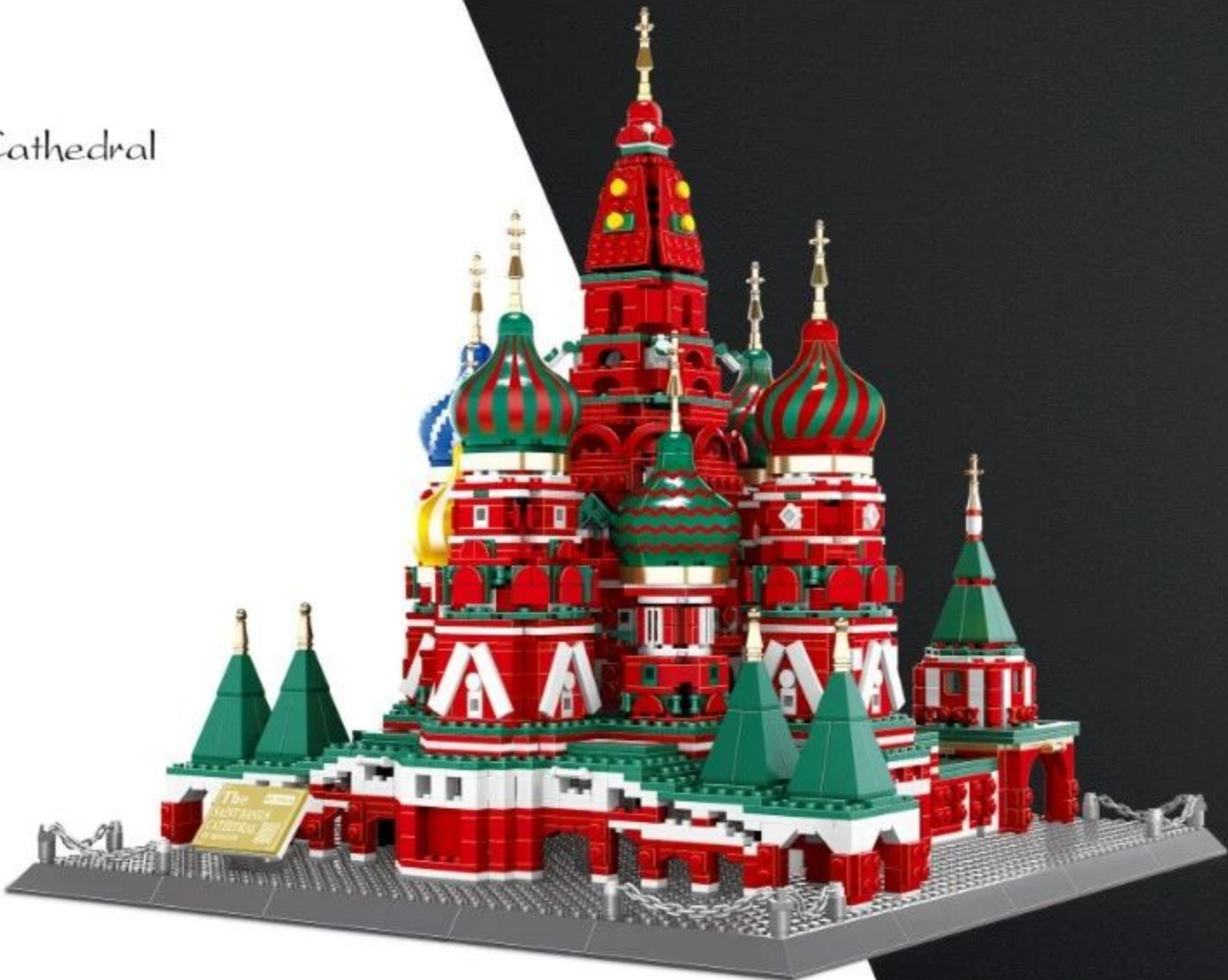

Product Size: 430X410X390mm

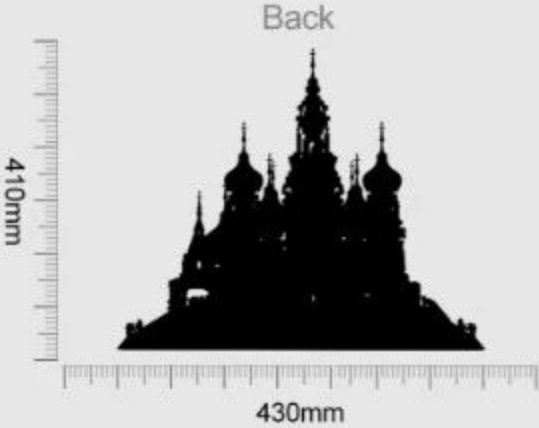
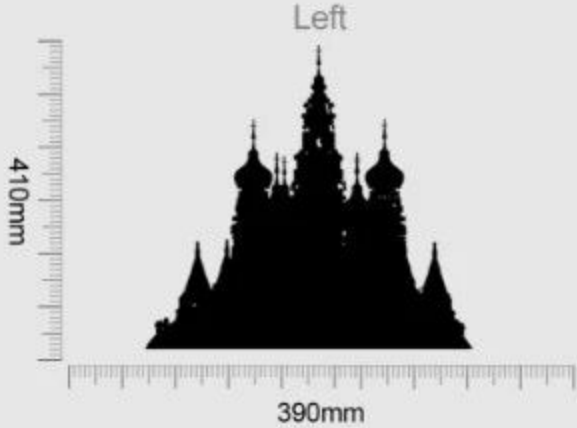
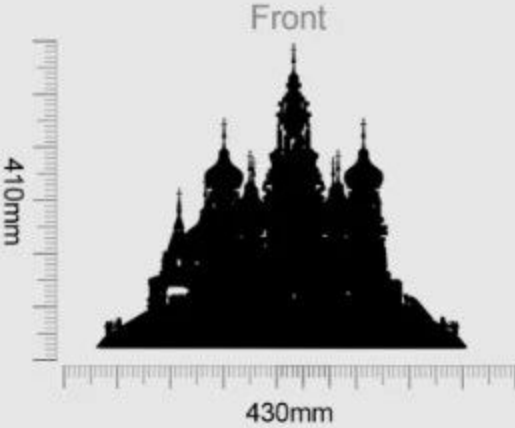



瓦西里大教堂

THE Saint Basil's Cathedral ■

Russia

The contents of this chapter refer to the Wikipedia website.

本章内容参考维基百科网站，更多资讯可自行查阅。

The world's great architecture

About The Building



THE CATHEDRAL OF VASILY THE BLESSED, commonly known as Saint Basil's Cathedral, is a Christian church in Red Square in Moscow, Russia and is regarded as a symbol of the country. The building, now a museum, is officially known as the Cathedral of the Intercession of the Most Holy Theotokos on the Moat. It was built from 1555 to 1561 on orders from Ivan the Terrible and commemorates the capture of Kazan and Astrakhan. It was the city's tallest building until the completion of the Ivan the Great Bell Tower in 1600.

The original building, known as Trinity Church and later Trinity Cathedral, contained eight churches arranged around a ninth, central church of Intercession; a tenth church was erected in 1588 over the grave of venerated local saint Vasily (Basil). In the 16th and 17th centuries, the church, perceived (as with all churches in Byzantine Christianity) as the earthly symbol of the Heavenly City, was popularly known as the "Jerusalem" and served as an allegory of the Jerusalem Temple in the annual Palm Sunday parade attended by the Patriarch of Moscow and the Tsar.



Design and construction

The building is shaped like the flame of a bonfire rising into the sky, a design that has no parallel in Russian architecture. Dmitry Shvidkovsky, in his book *Russian Architecture and the West*, states that "it is like no other Russian building. Nothing similar can be found in the entire millennium of Byzantine tradition from the fifth to the fifteenth century ... a strangeness that astonishes by its unexpectedness, complexity and dazzling interleaving of the manifold details of its design." The cathedral foreshadowed the climax of Russian national architecture in the 17th century

Construction under Ivan IV

The site of the church had been, historically, a busy marketplace between the St. Frol's Gate of the Moscow Kremlin and the outlying posad. The centre of the marketplace was marked by the Trinity Church, built of the same white stone as the Kremlin of Dmitry Donskoy (1366–68) and its cathedrals. Tsar Ivan IV marked every victory of the Russo-Kazan War by erecting a wooden memorial church next to the walls of Trinity Church; by the end of his Astrakhan campaign, it was shrouded within a cluster of seven wooden churches. According to the report in Nikon's Chronicle, in the autumn of 1554 Ivan ordered the construction of the wooden Church of Intercession on the same site, "on the moat". One year later, Ivan ordered the construction of a new stone cathedral on the site of Trinity Church to commemorate his campaigns. Dedication of a church to a military victory was "a major innovation" for Muscovy.



Architectural style and Layout

Because the church has no analogue—in preceding, contemporary, or later architecture of Muscovy and Byzantine cultural tradition in general—the sources that inspired Barma and Postnik are disputed. Eugène Viollet-le-Duc rejected European roots for the cathedral, opining that its corbel arches were Byzantine and ultimately Asian. A modern "Asian" hypothesis considers the cathedral a recreation of Qolşärif Mosque, which was destroyed by Russian troops after the siege of Kazan.



Instead of following the original ad hoc layout (seven churches around the central core), Ivan's architects opted for a more symmetrical floor plan with eight side churches around the core, producing "a thoroughly coherent, logical plan" despite the erroneous latter "notion of a structure devoid of restraint or reason" influenced by the memory of Ivan's irrational atrocities.

Main Color Matching

配色方案



Pantone 457C



Pantone 3435 C



Pantone 7620C



Pantone 123 C



Pantone 285C



Pantone cool gray2C



Pantone cool gray9C



Pantone Black 6C



Color matching

Adopting 8 main colors, beige, brown and gray as the main color, the more reasonable and bold color matching on the original building, making the product more atmospheric and the whole design is more reasonable.

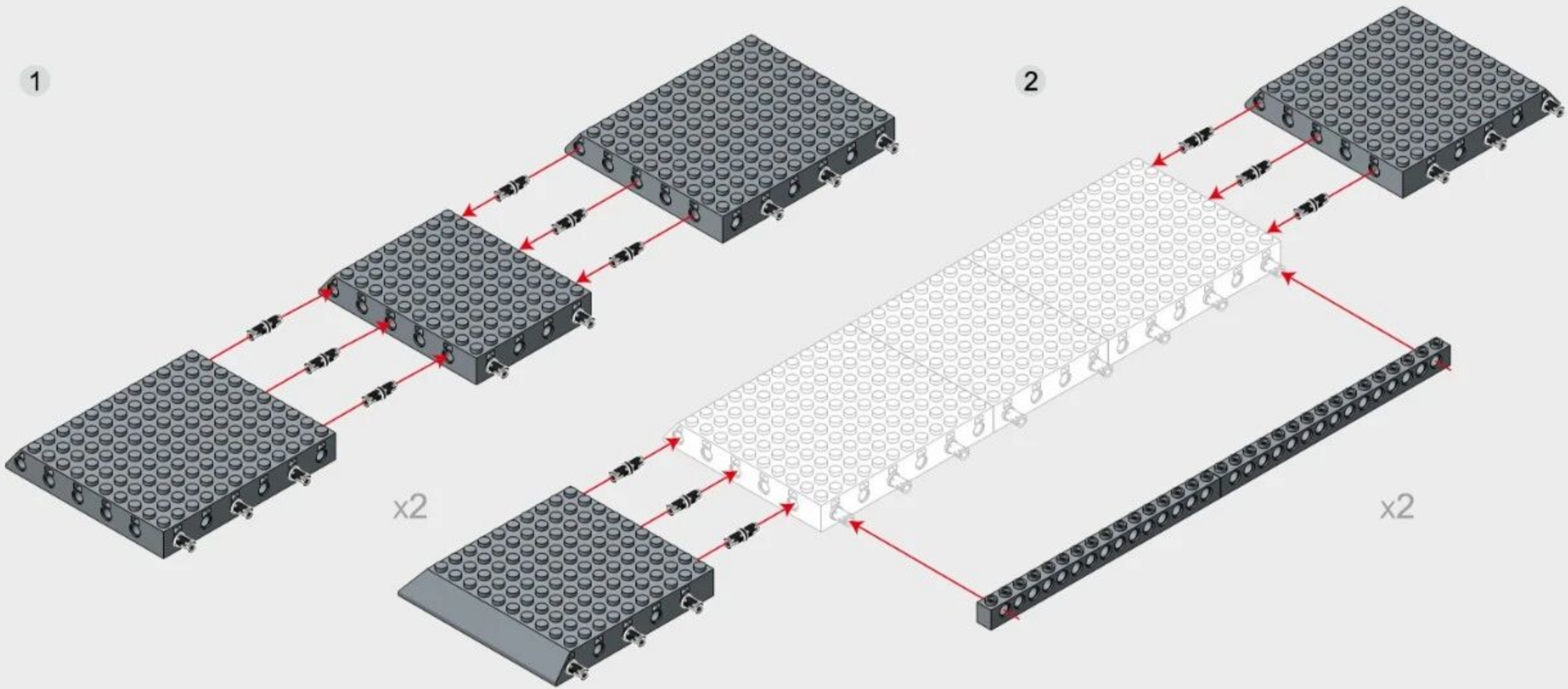
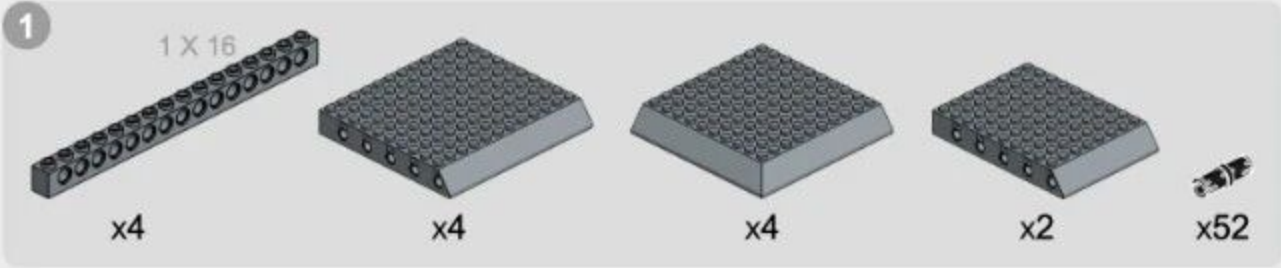

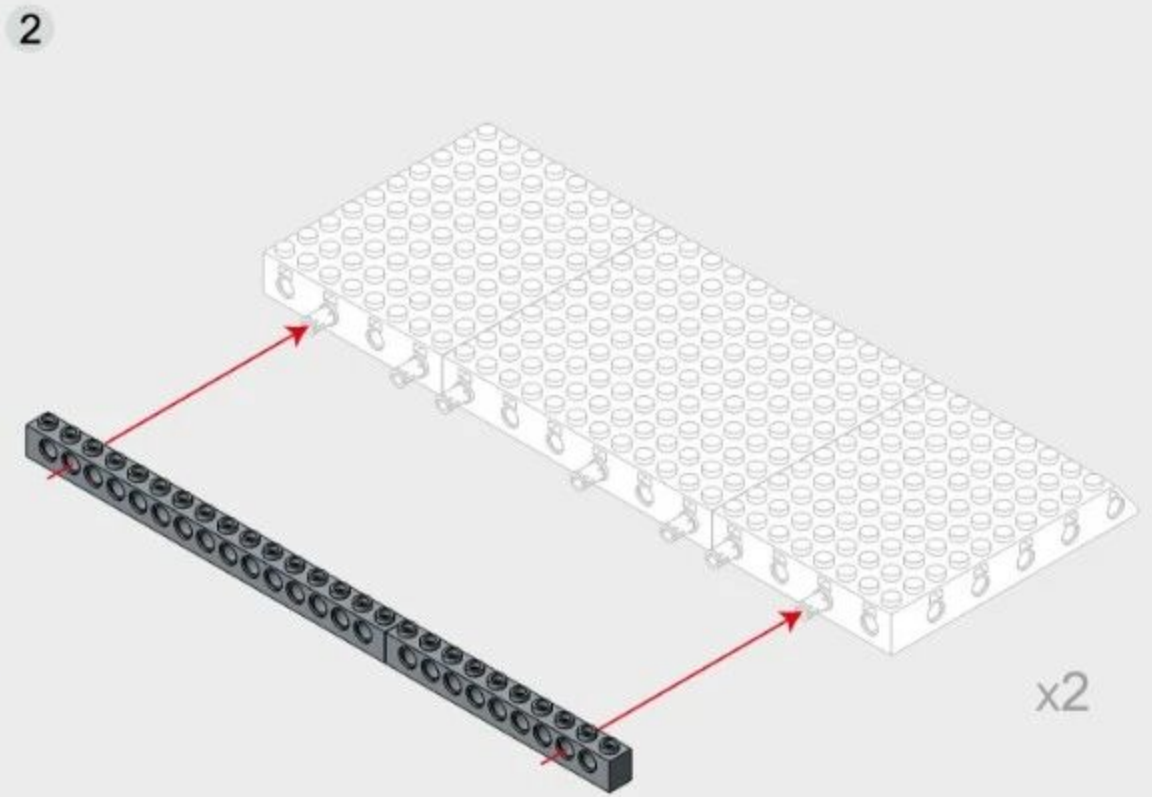
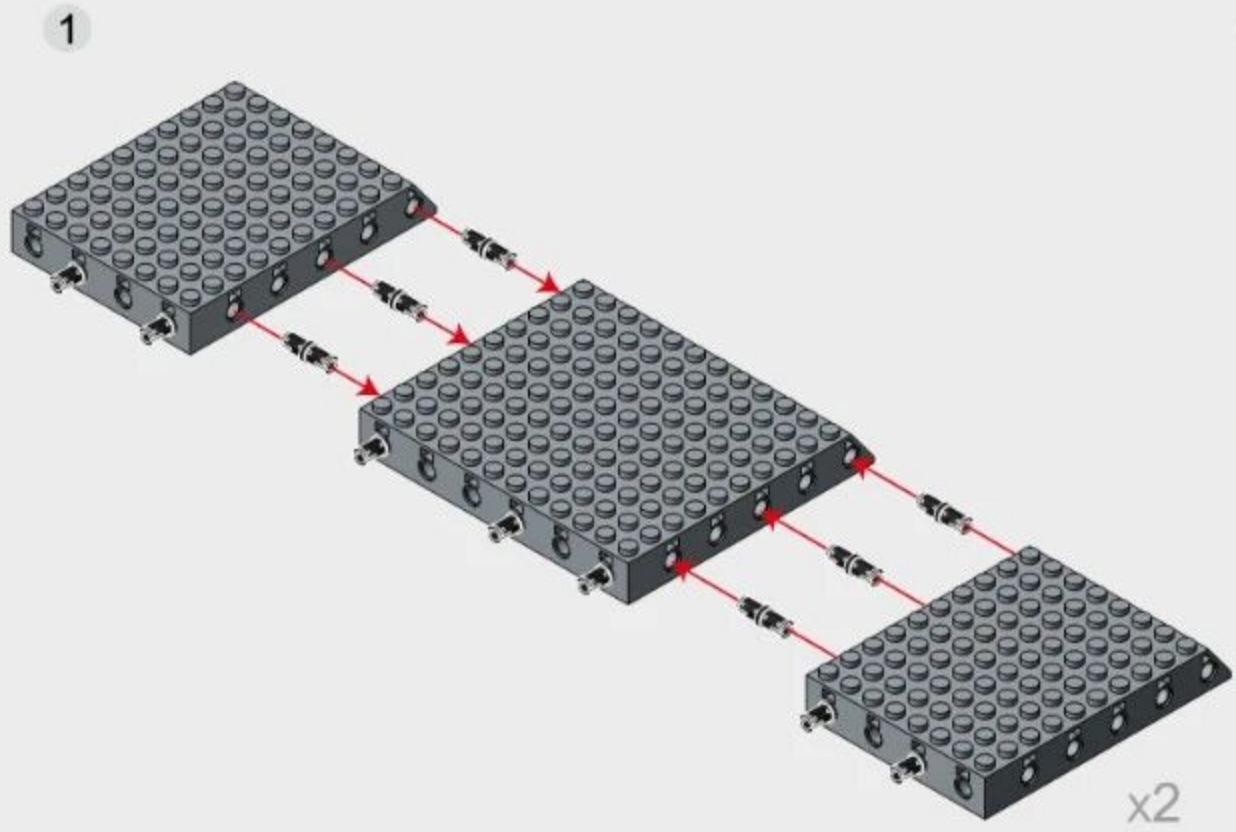
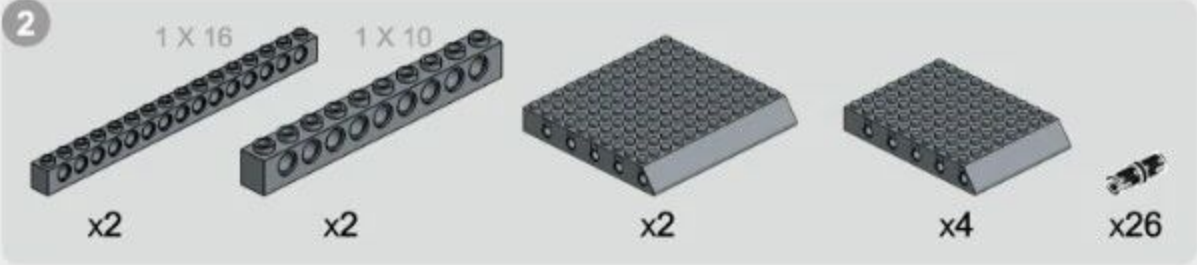

3
1 + 2

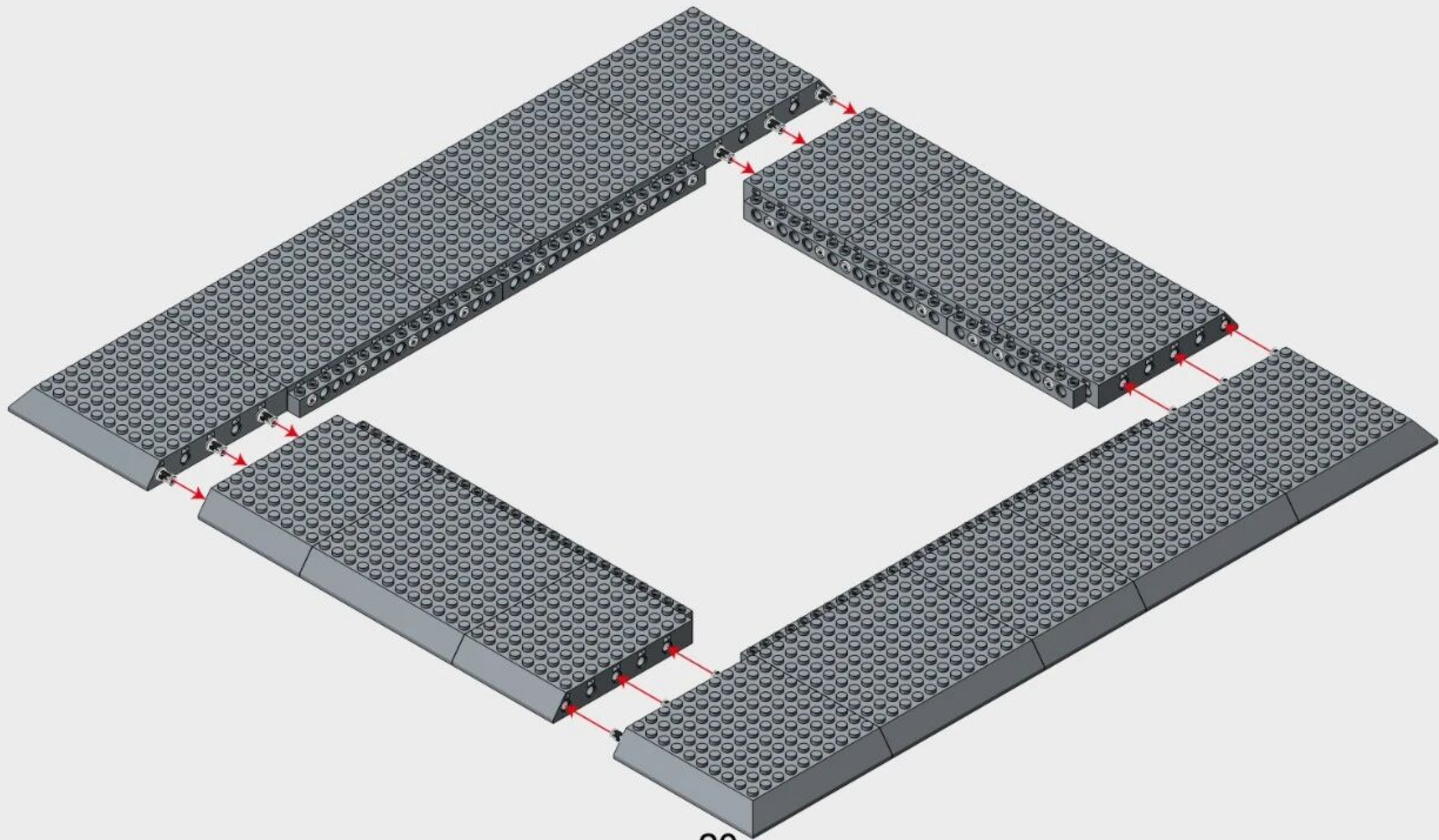

20

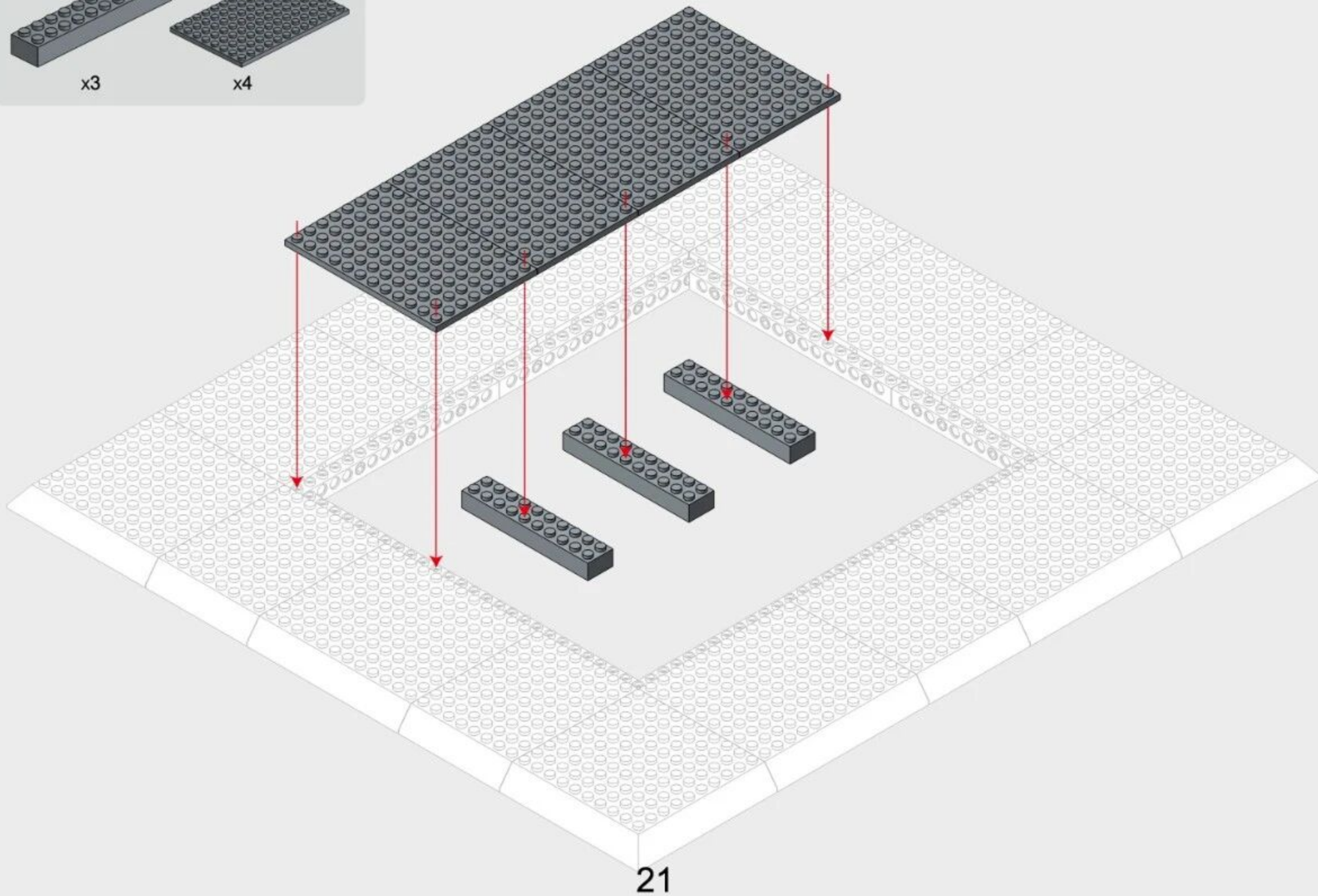
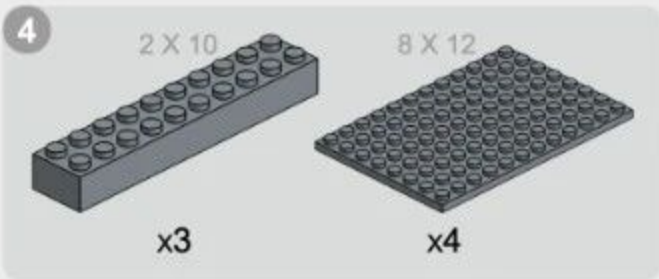

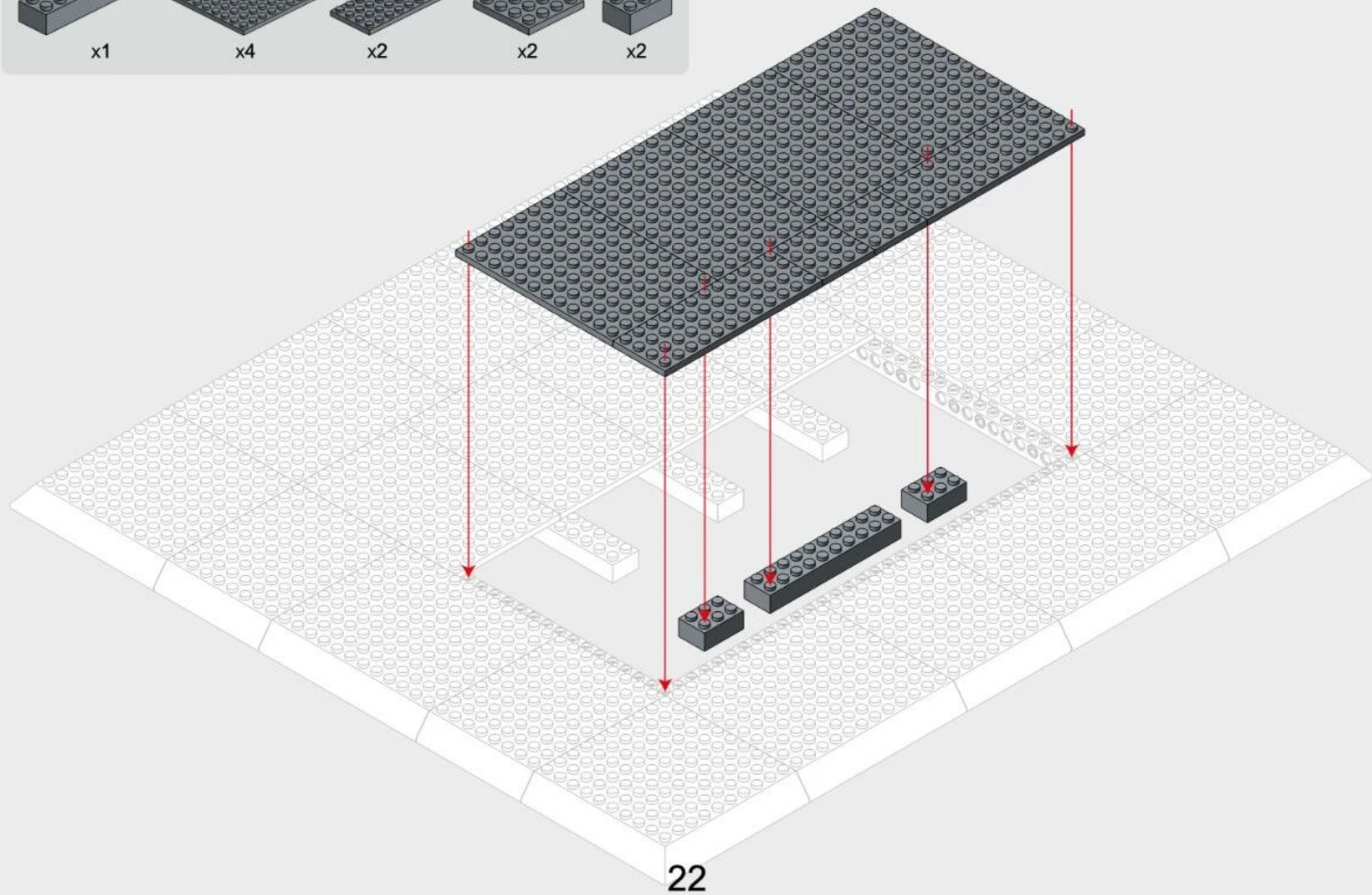
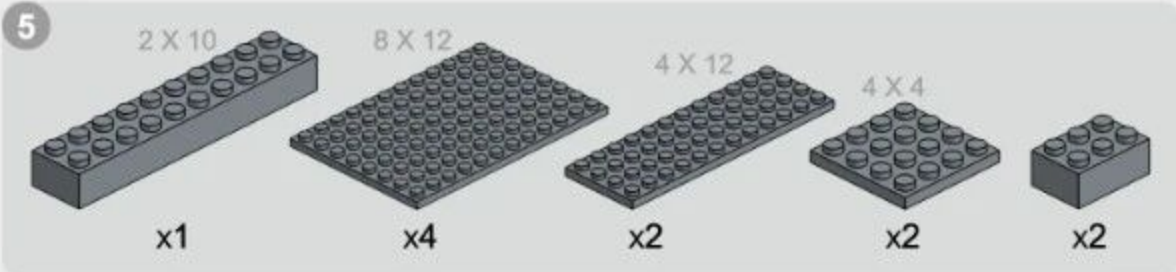





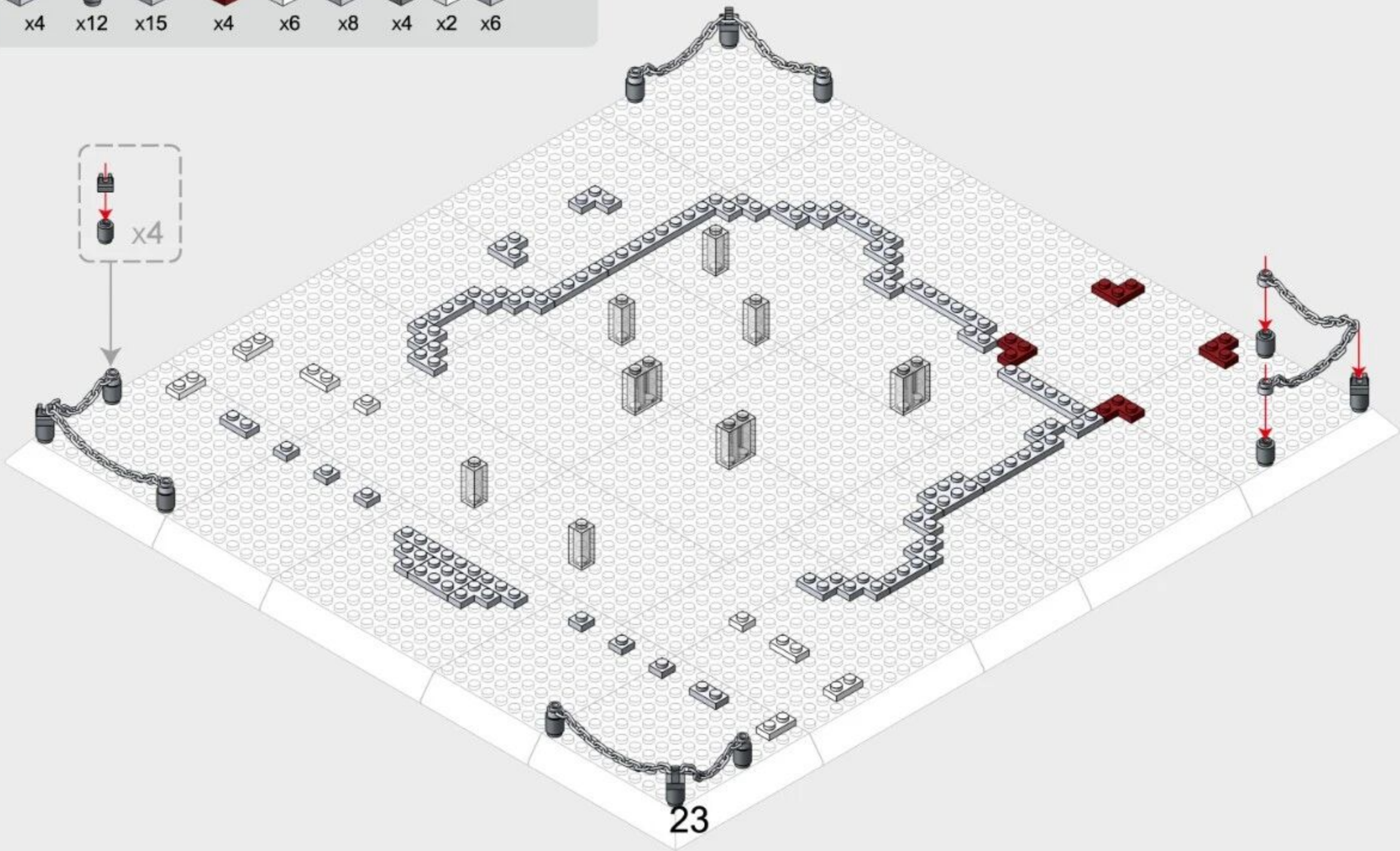

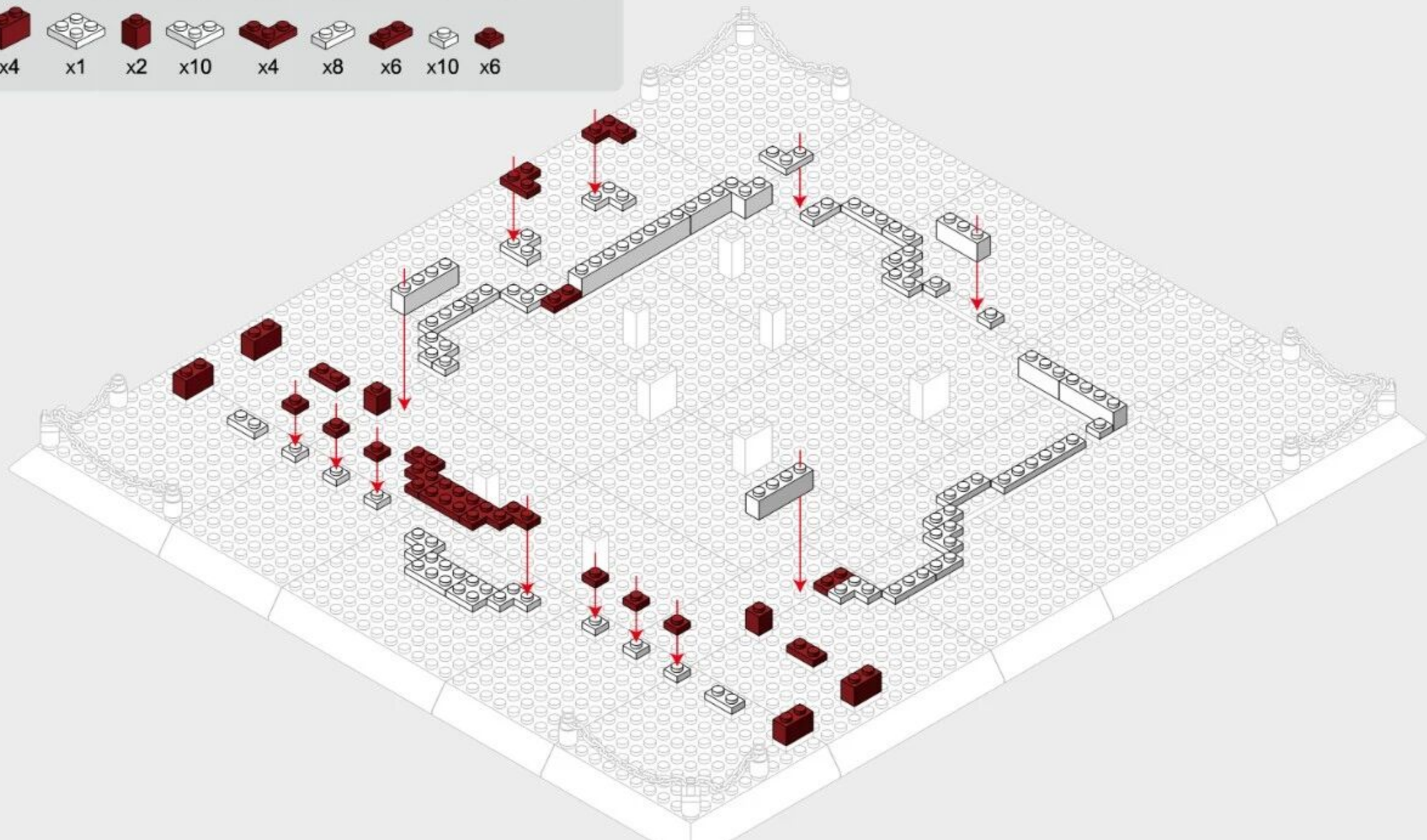
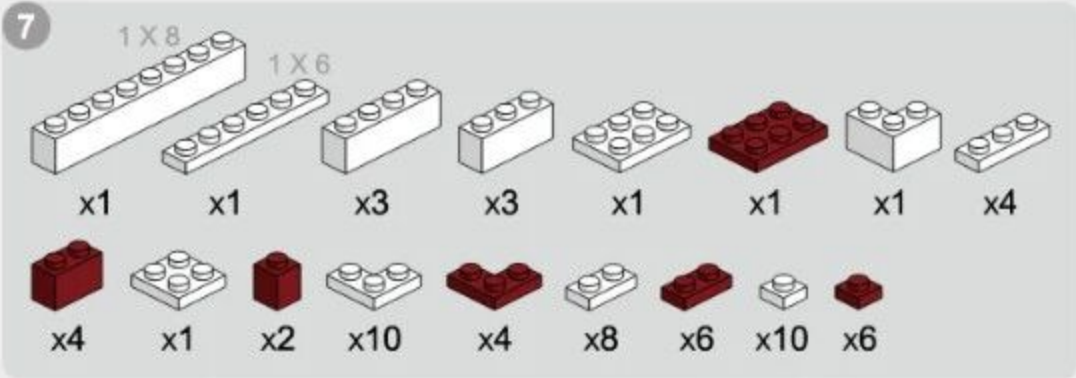







6

- 1 X 8
- x4
- x1
- x3
- x5
- 1 X 6
- x4
- x1
- x2
- x4
- x12
- x15
- x4
- x6
- x8
- x4
- x2
- x6





8

-  x2
-  x1
-  x2
-  x1
-  x3
-  x3
-  x10
-  x10
-  x12
-  x2
-  x4
-  x1
-  x2
-  x12

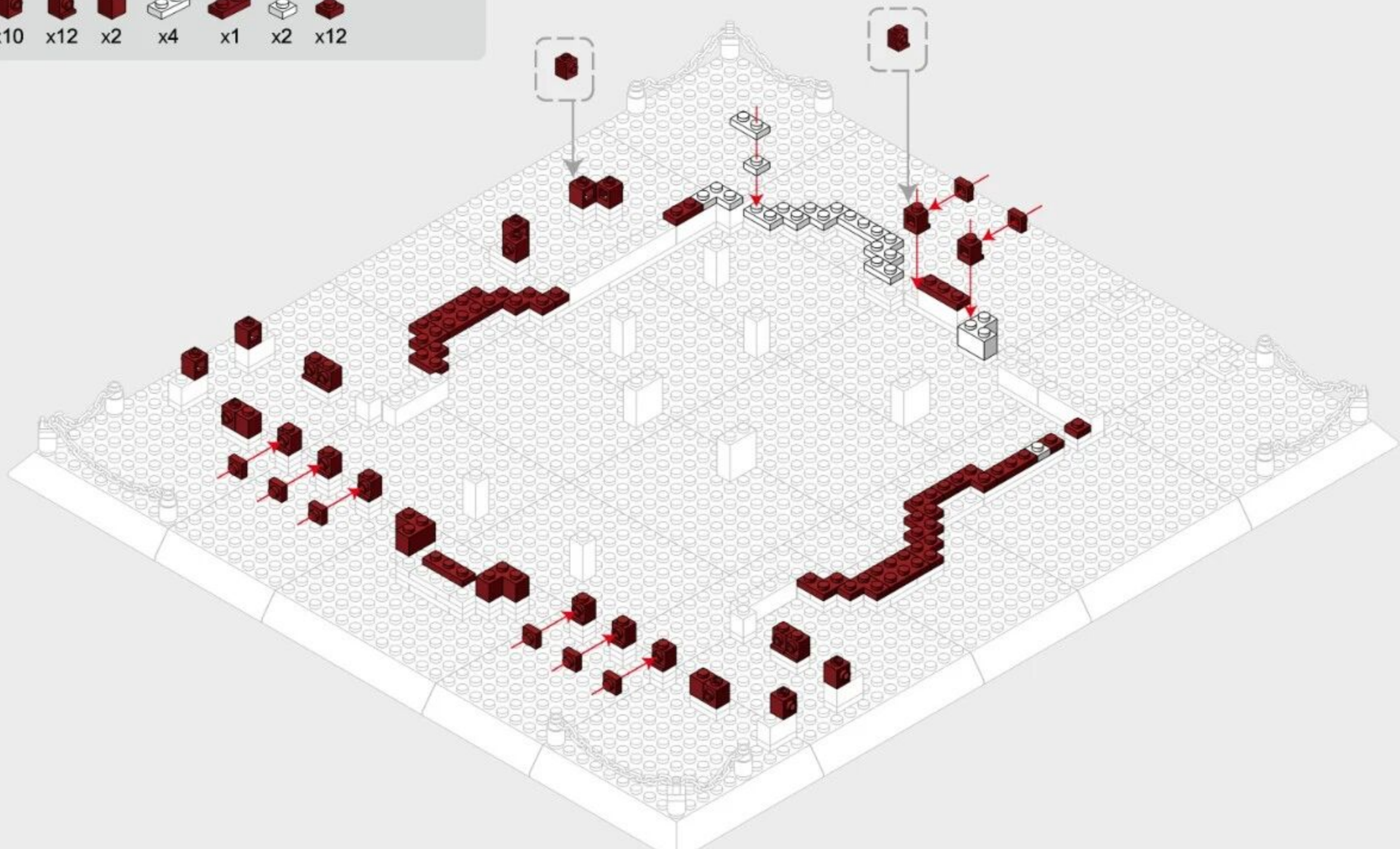





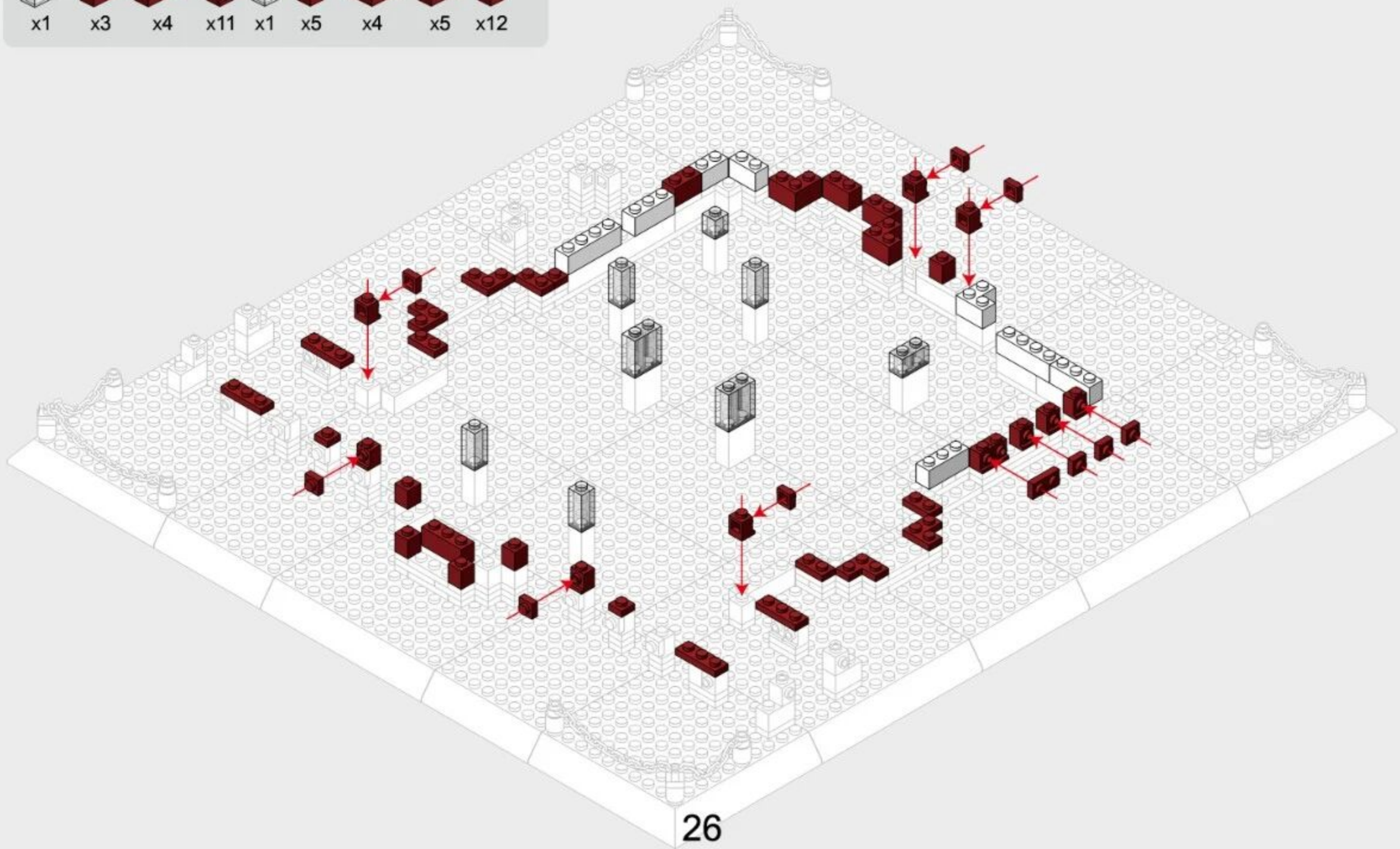











9

- | | | | | | | | | |
|----|----|----|-----|----|----|----|----|-----|
| | | | | | | | | |
| x2 | x4 | x2 | x3 | x1 | x1 | x2 | x2 | |
| | | | | | | | | |
| x1 | x3 | x4 | x11 | x1 | x5 | x4 | x5 | x12 |



10

- | | | | | | | | |
|---|---|---|---|---|---|---|---|
|  |  |  |  |  |  |  |  |
| x2 | x1 | x1 | x1 | x1 | x3 | x1 | x2 |
|  |  |  |  |  |  |  |  |
| x4 | x6 | x8 | x3 | x4 | x8 | x4 | x4 |

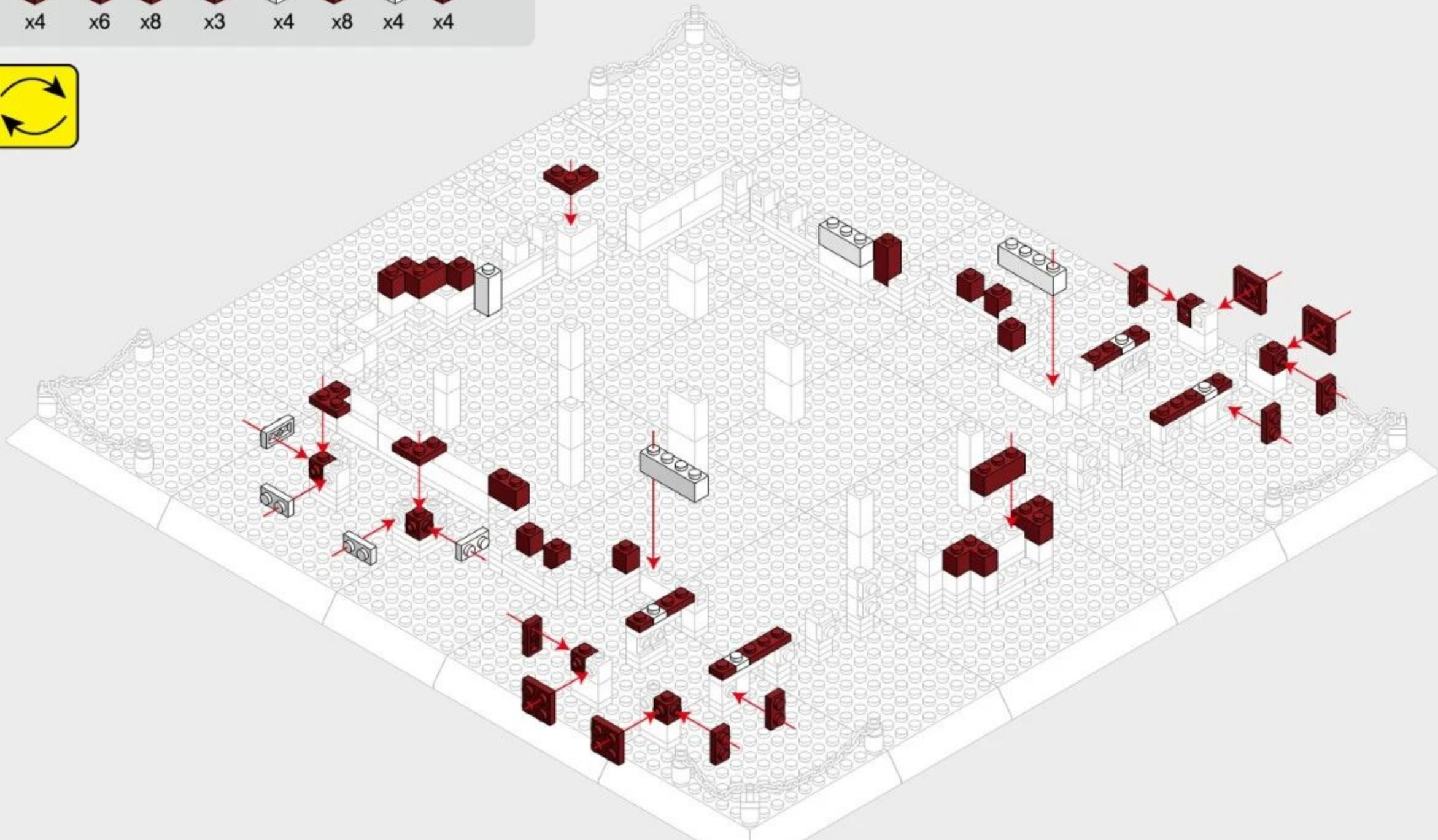

- 11
- x2 (1x6 white Technic beam)
 - x2 (1x6 dark red Technic beam)
 - x1 (1x6 dark red Technic beam)
 - x2 (1x6 white Technic beam)
 - x1 (1x6 white Technic beam)
 - x1 (1x6 dark red Technic beam)
 - x1 (1x6 white Technic beam)
 - x2 (1x6 white Technic beam)
 - x2 (1x6 dark red Technic beam)
 - x5 (1x6 dark red Technic beam)
 - x2 (1x6 white Technic beam)
 - x1 (1x6 dark red Technic beam)
 - x5 (1x6 dark red Technic beam)
 - x1 (1x6 white Technic beam)
 - x7 (1x6 dark red Technic beam)
 - x1 (1x6 dark red Technic beam)
 - x2 (1x6 dark red Technic beam)
 - x2 (1x6 white Technic beam)
 - x1 (1x6 dark red Technic beam)
 - x4 (1x6 dark red Technic beam)
 - x4 (1x6 white Technic beam)
 - x6 (1x6 dark red Technic beam)

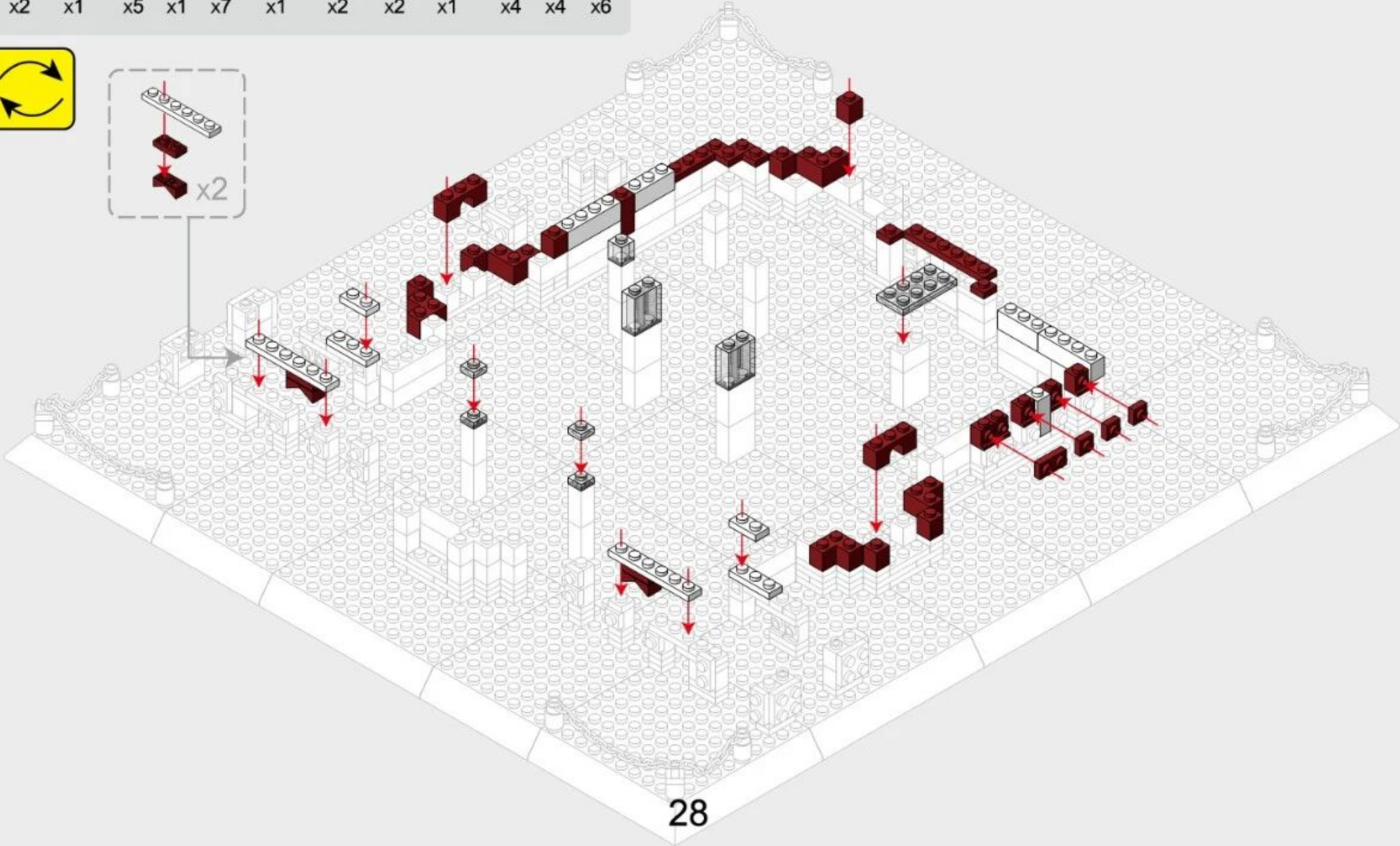
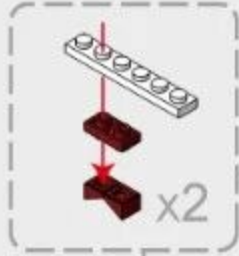

12

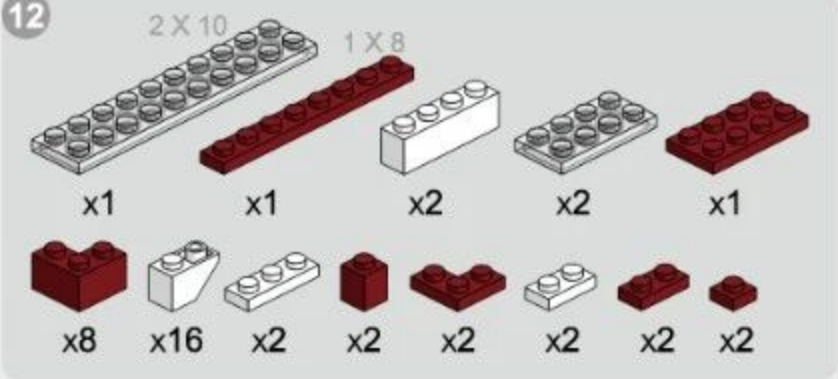

13

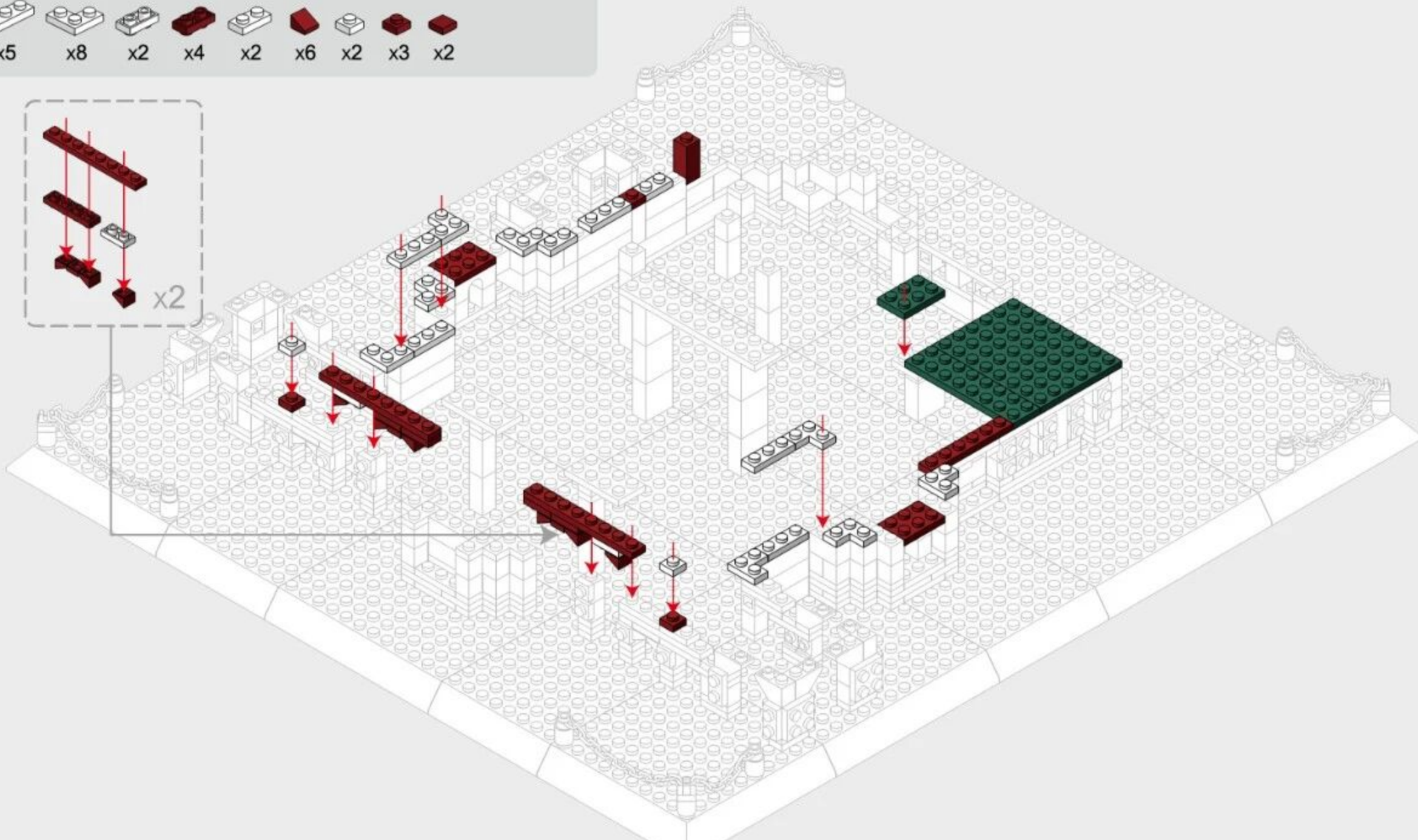
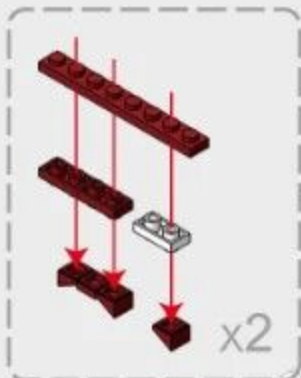
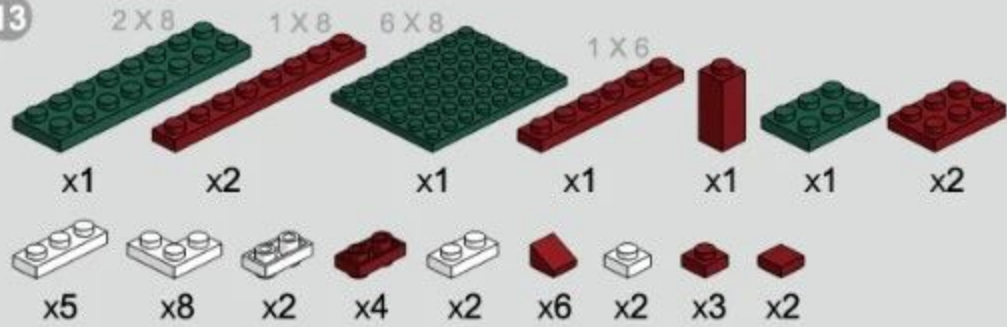

14

2 X 6

1 X 6

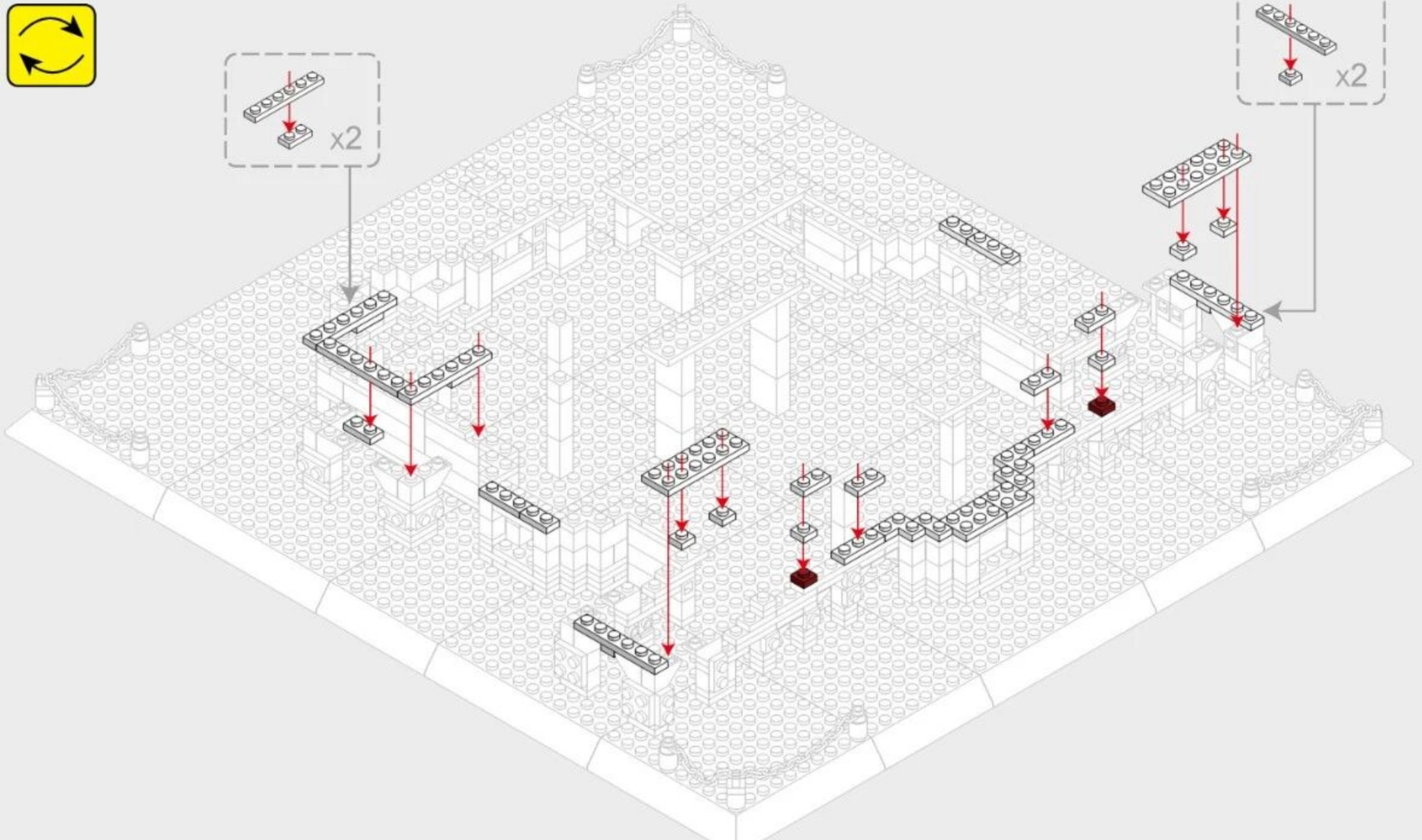
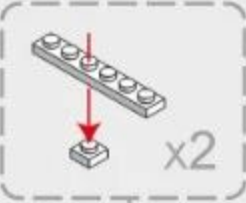
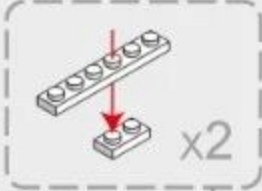
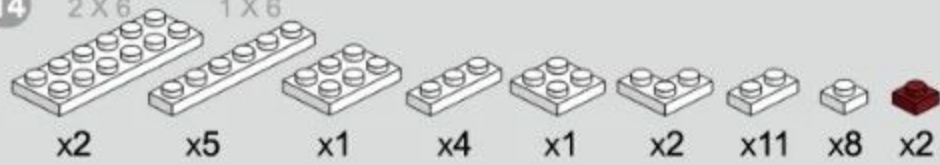

15

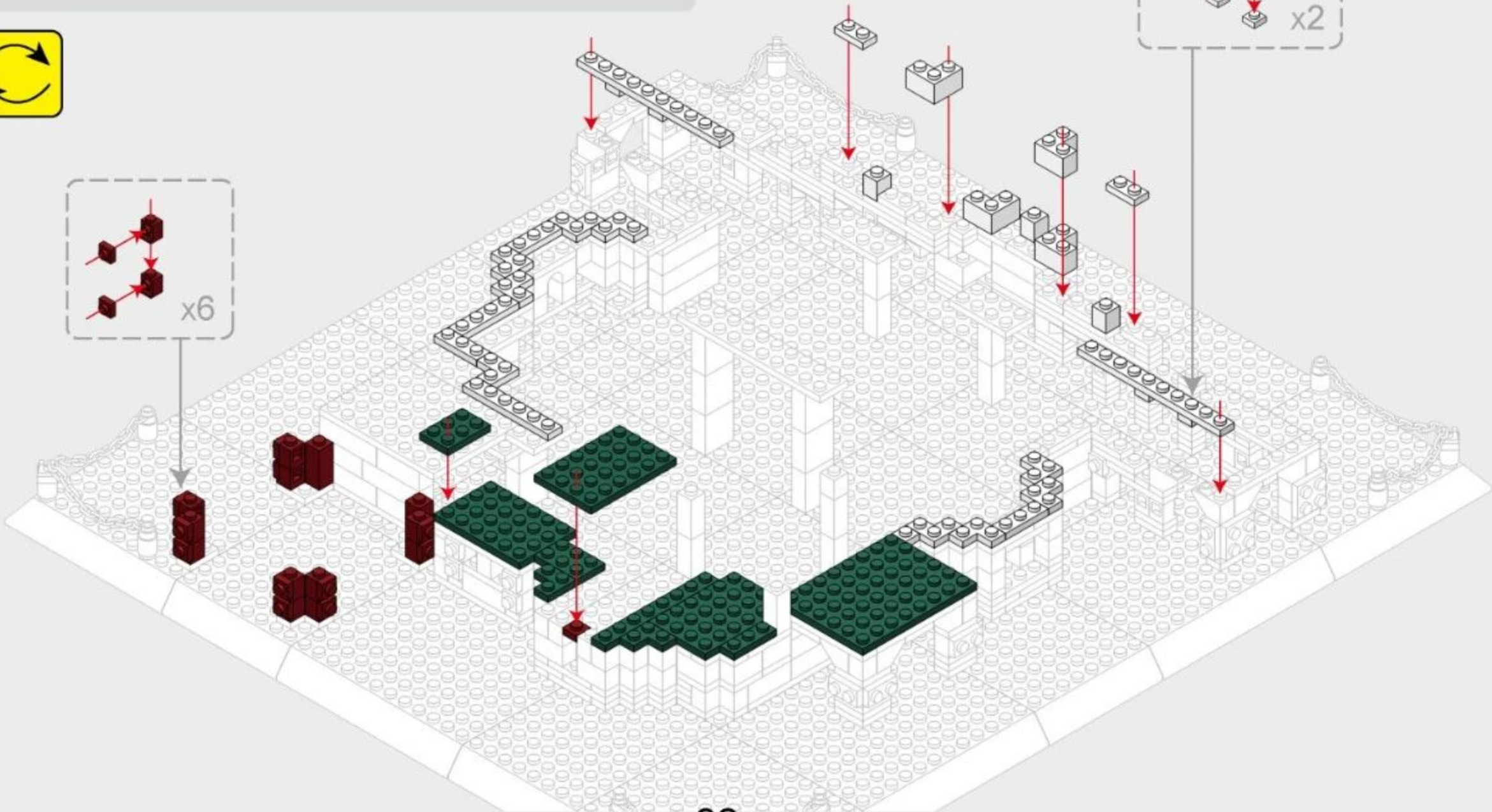
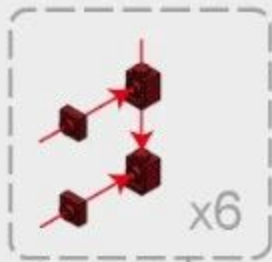
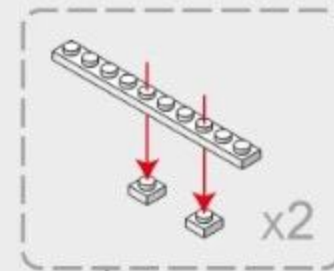
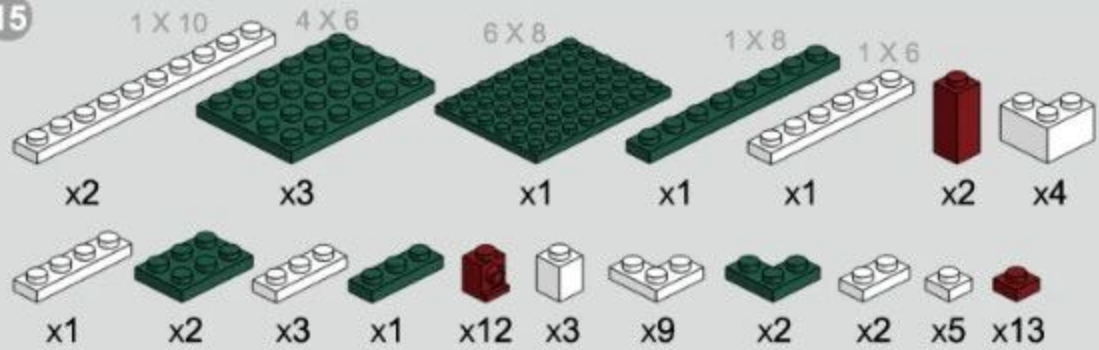

16

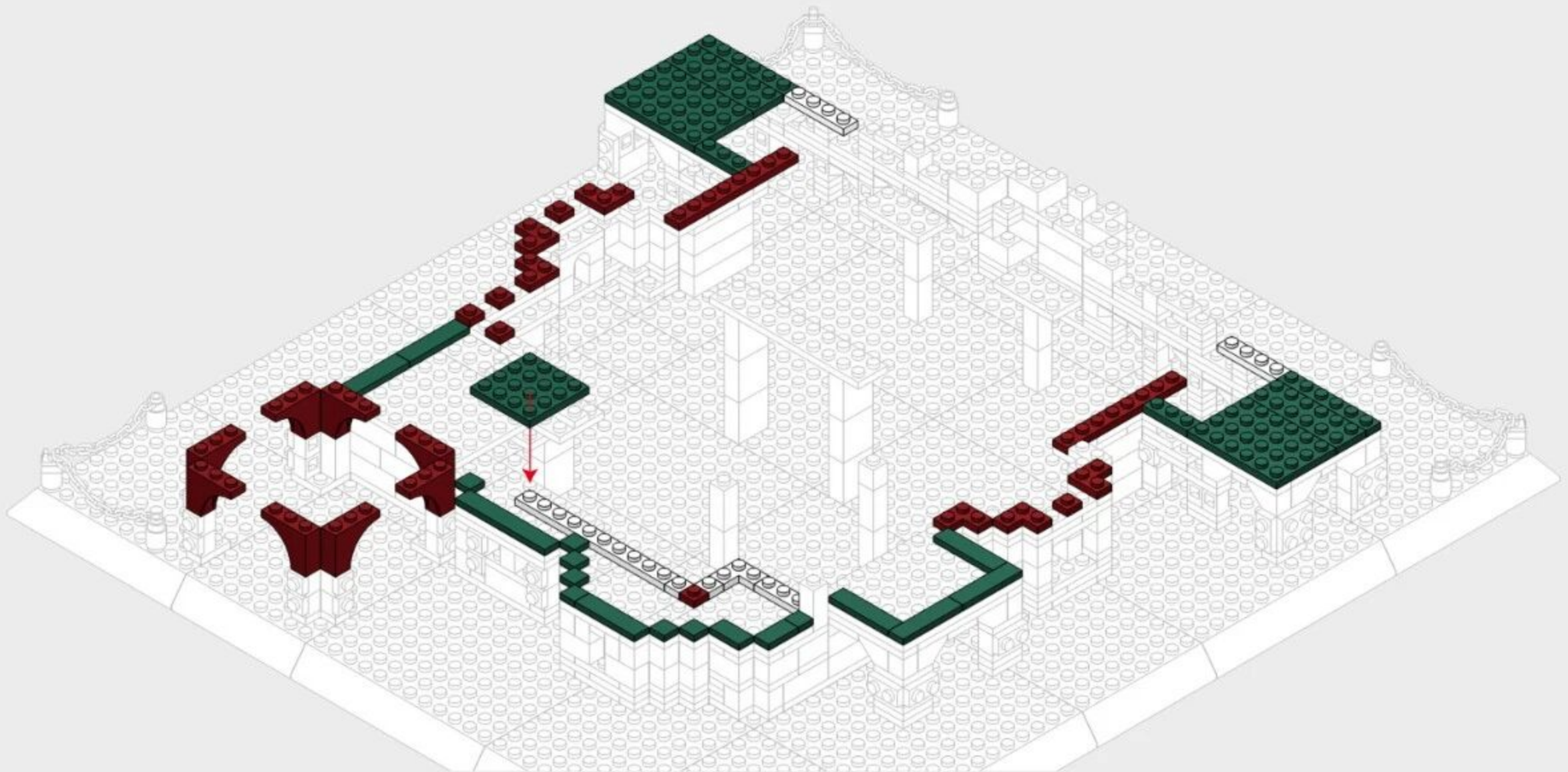
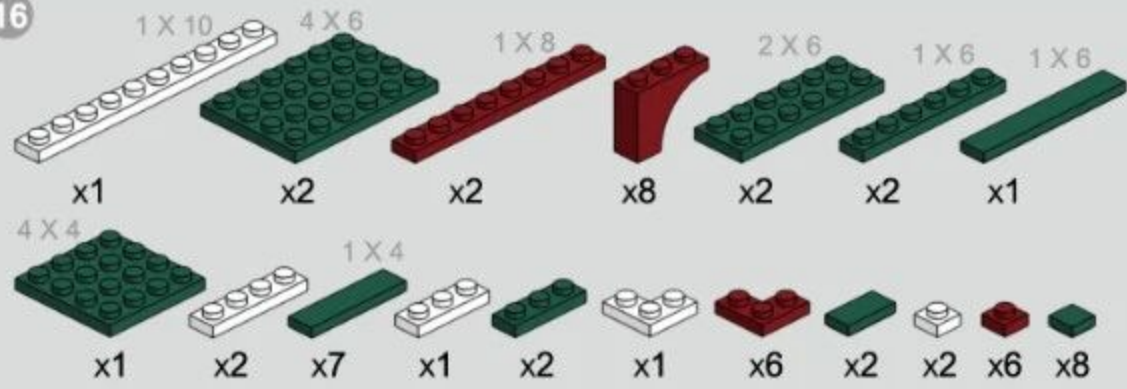

17

- 1 X 10
- 4 X 6
- 1 X 8
- 2 X 6
- x1
- x2
- x4
- x2
- x2
- x1
- x3
- x3
- x2
- x3
- x1
- x3
- x1
- x2
- x1
- x14

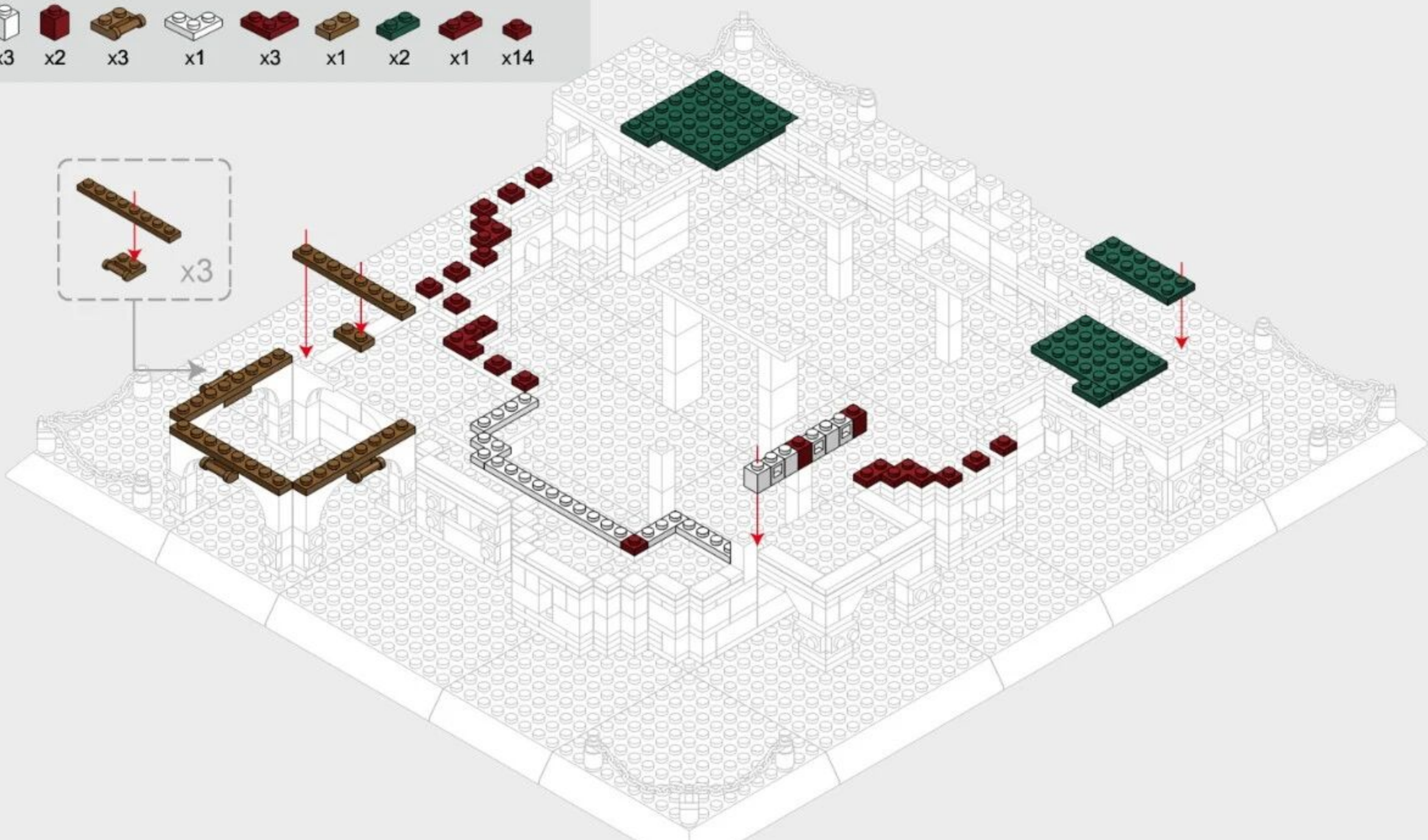

18

- 2 X 10 (dark green) x2
- 6 X 10 (dark green) x1
- 6 X 8 (dark green) x1
- 1 X 6 (dark green) x2
- 1 X 4 (dark green) x6
- 1 X 4 (white) x3
- 1 X 2 (dark green) x1
- 1 X 2 (dark red) x2
- 1 X 2 (white) x2
- 1 X 2 (white) x2
- 1 X 2 (white) x2
- 1 X 2 (dark red) x5
- 1 X 2 (dark red) x4
- 1 X 2 (white) x2
- 1 X 2 (dark red) x2
- 1 X 2 (dark red) x2
- 1 X 2 (dark red) x4
- 1 X 2 (white) x2
- 1 X 2 (dark red) x6



19

- 2x6 (dark green) x2
- 1x6 (white) x2
- 1x6 (dark green) x2
- 1x6 (dark red) x1
- 1x6 (white) x2
- 1x6 (white) x1
- 1x6 (dark red) x2
- 1x3 (white) x1
- 1x2 (dark green) x16
- 1x2 (white) x4
- 1x2 (dark red) x4
- 1x2 (white) x5
- 1x2 (white) x4
- 1x2 (dark red) x4
- 1x2 (dark green) x16



20

1 X 8

2 X 6

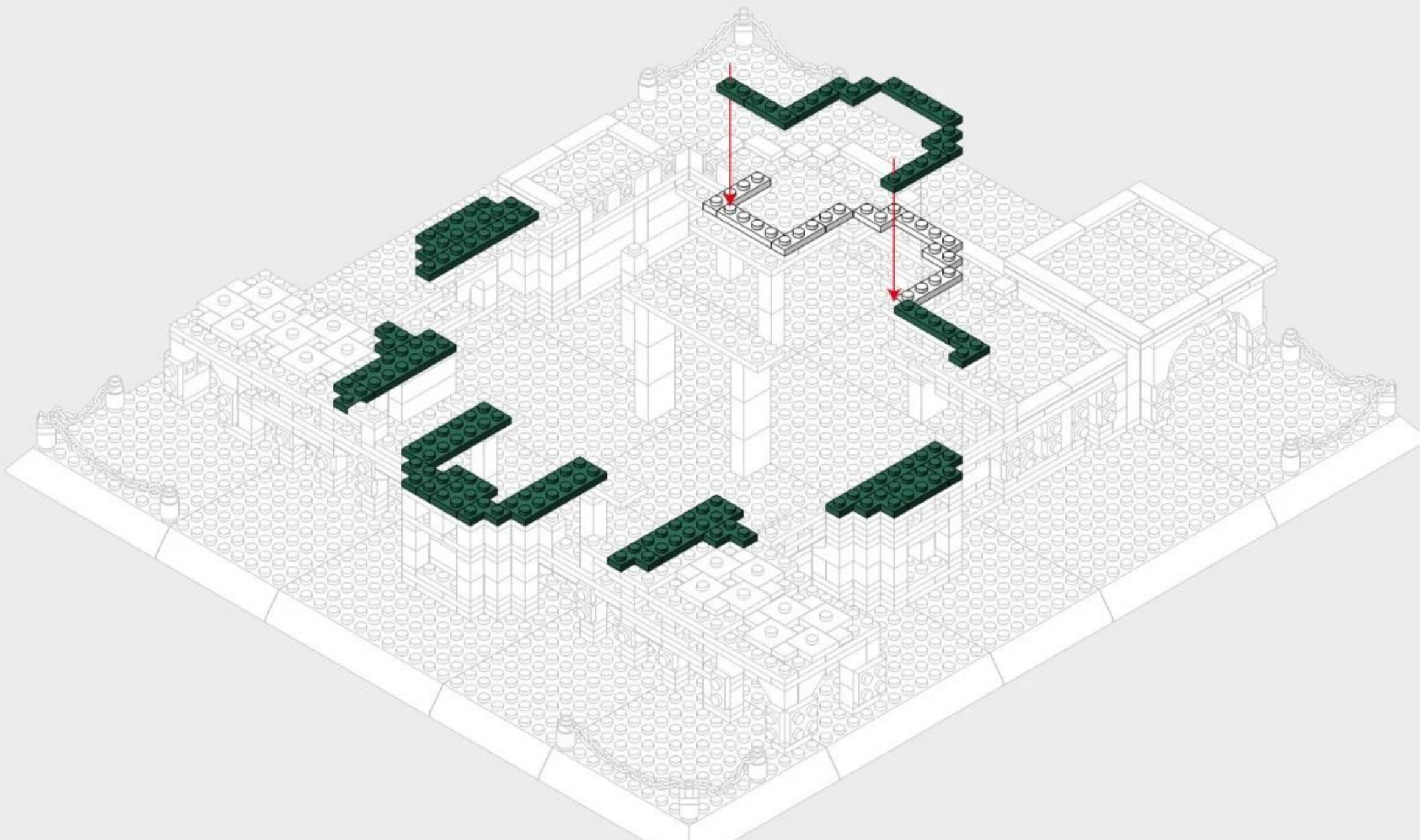
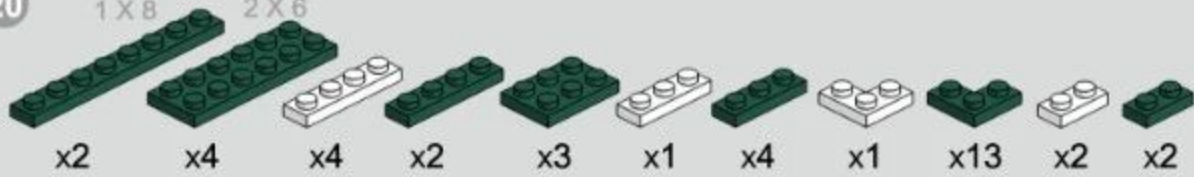

21

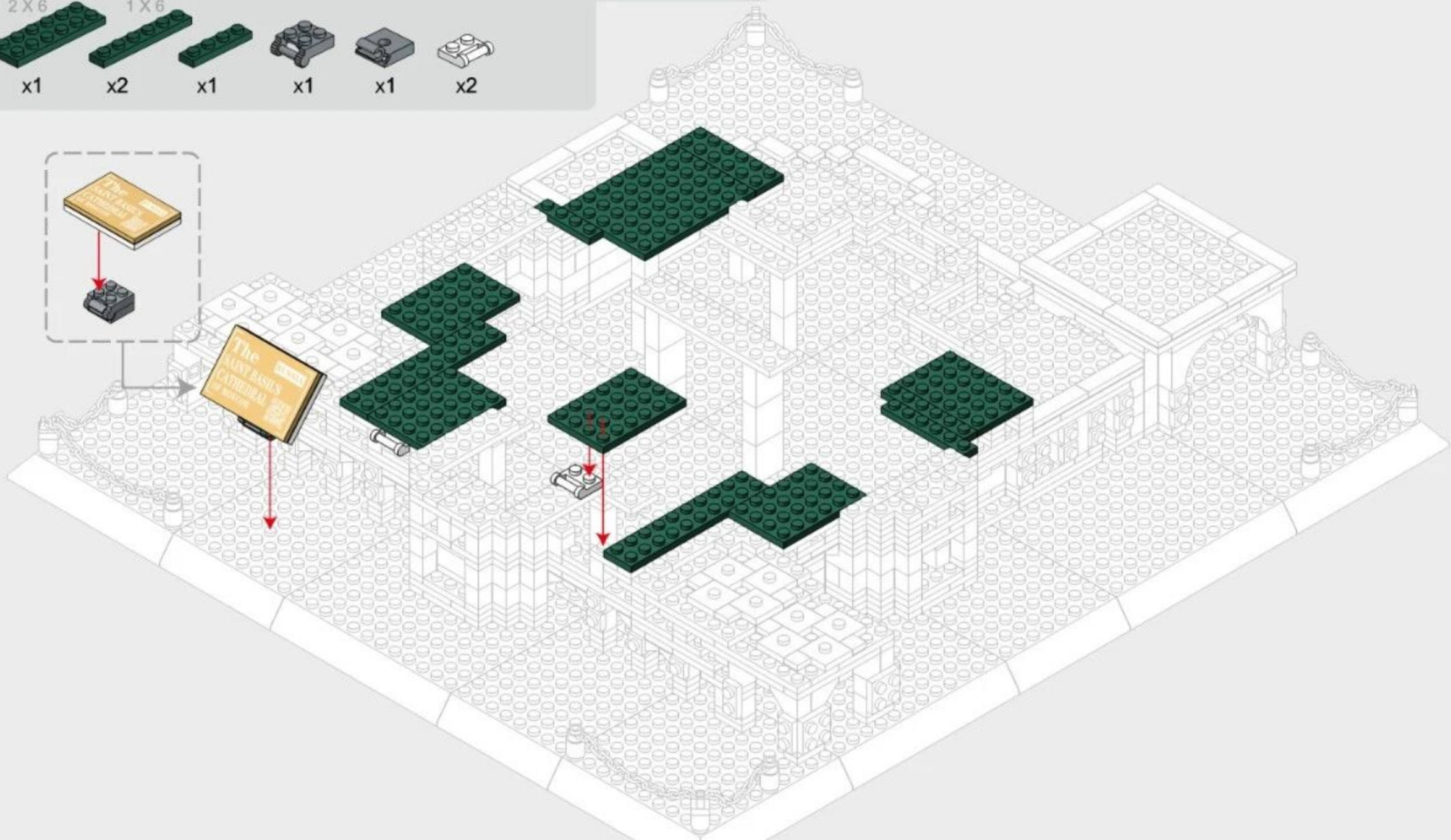
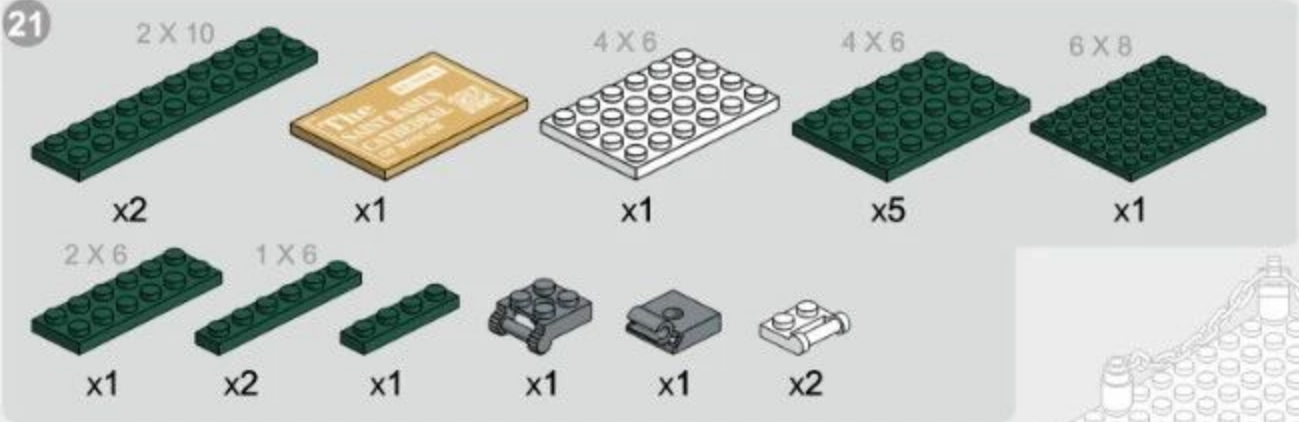

22

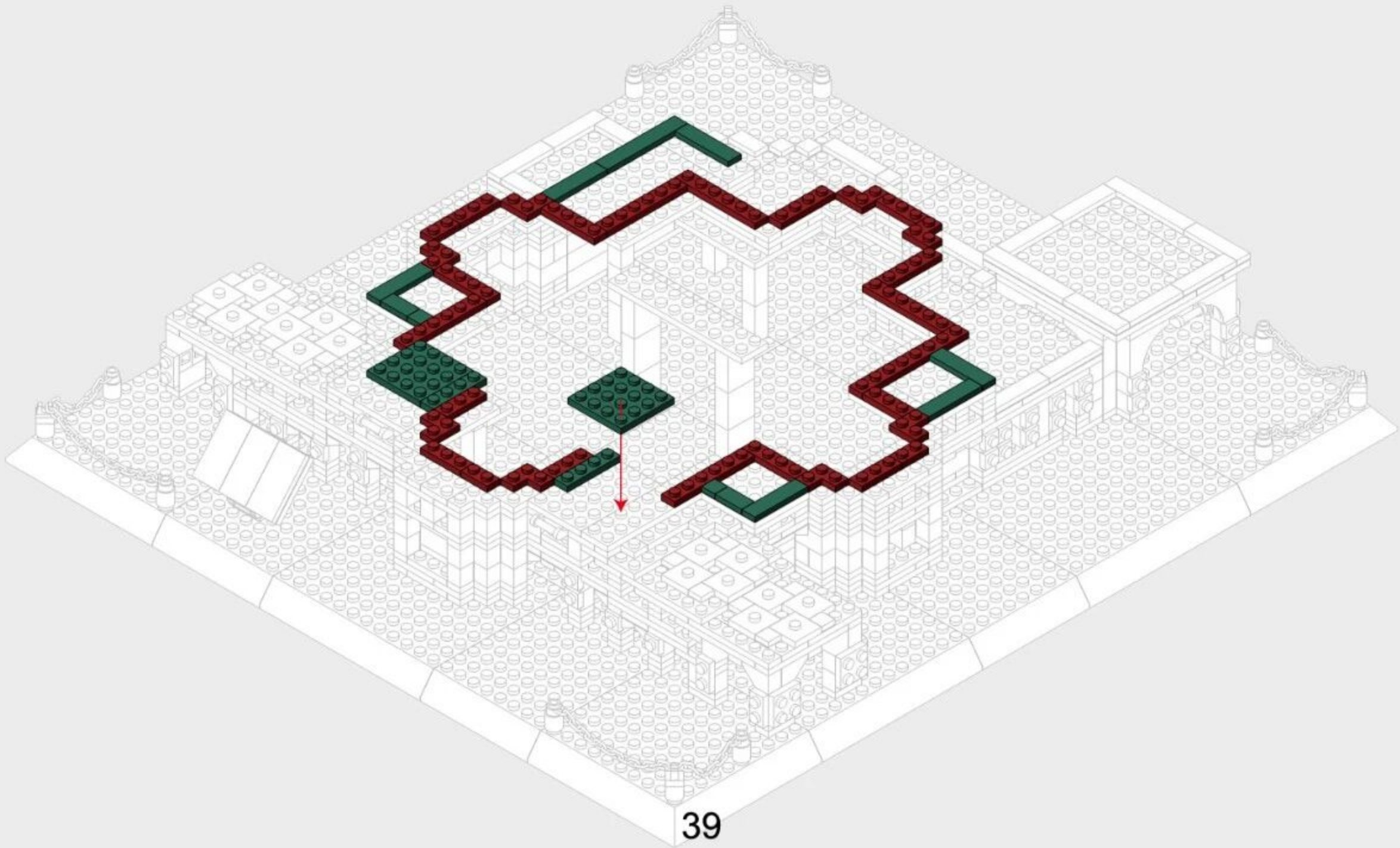
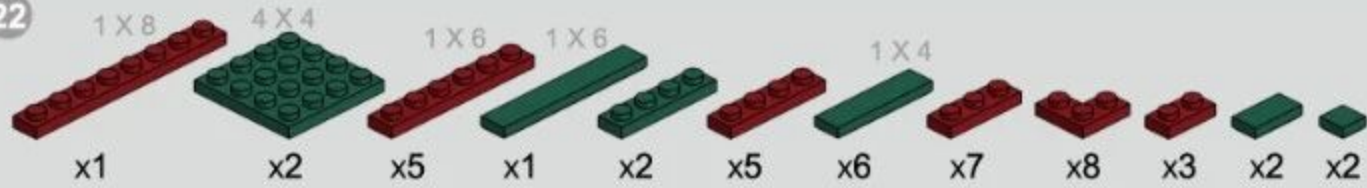

23

- 1 x 4
- x4
- x2
- x15
- x19
- x2
- x2
- x2

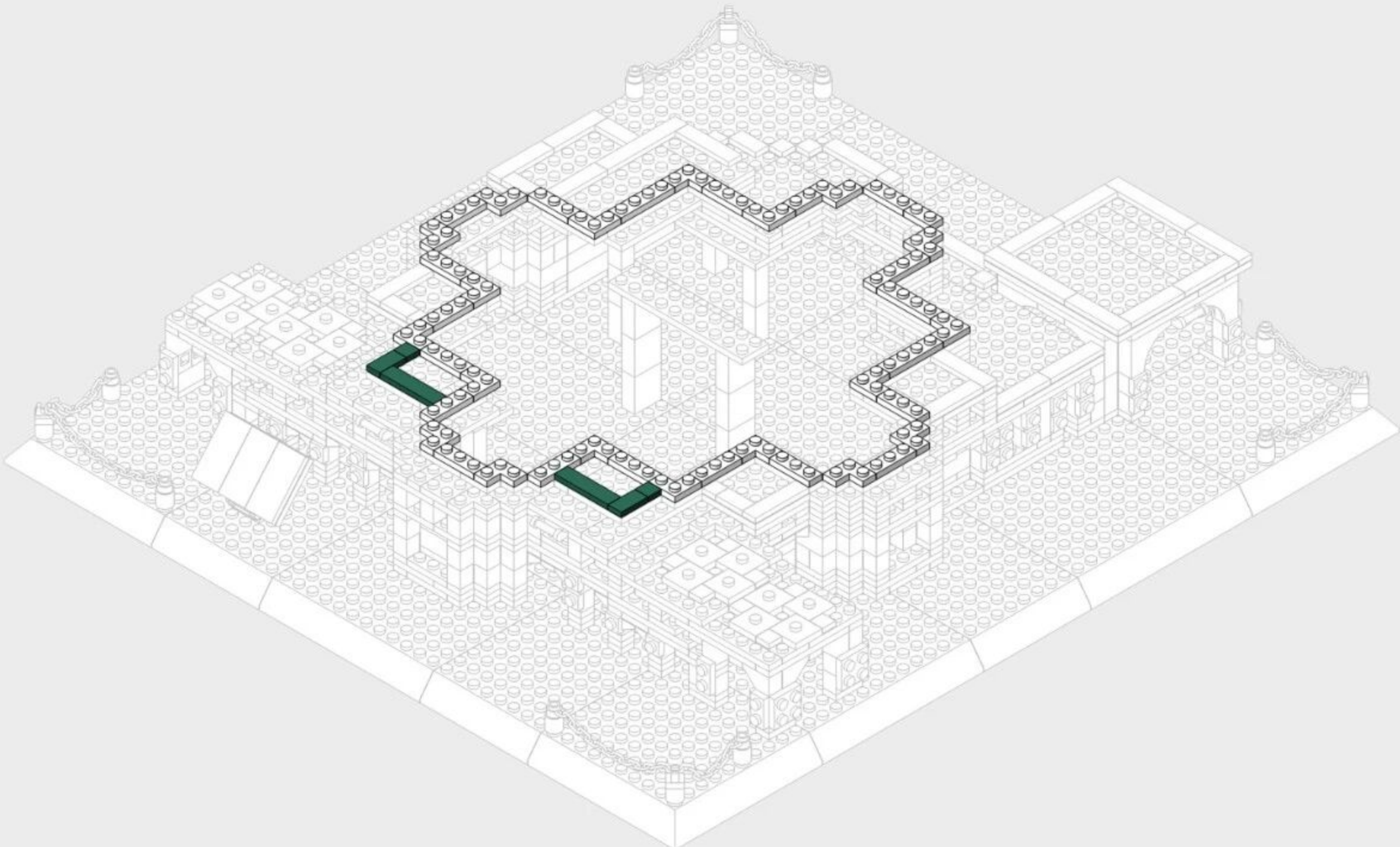

24

2 X 10

1 X 10

2 X 6



x2

x2

x4

x2

x2

x6

x6

x8

x3

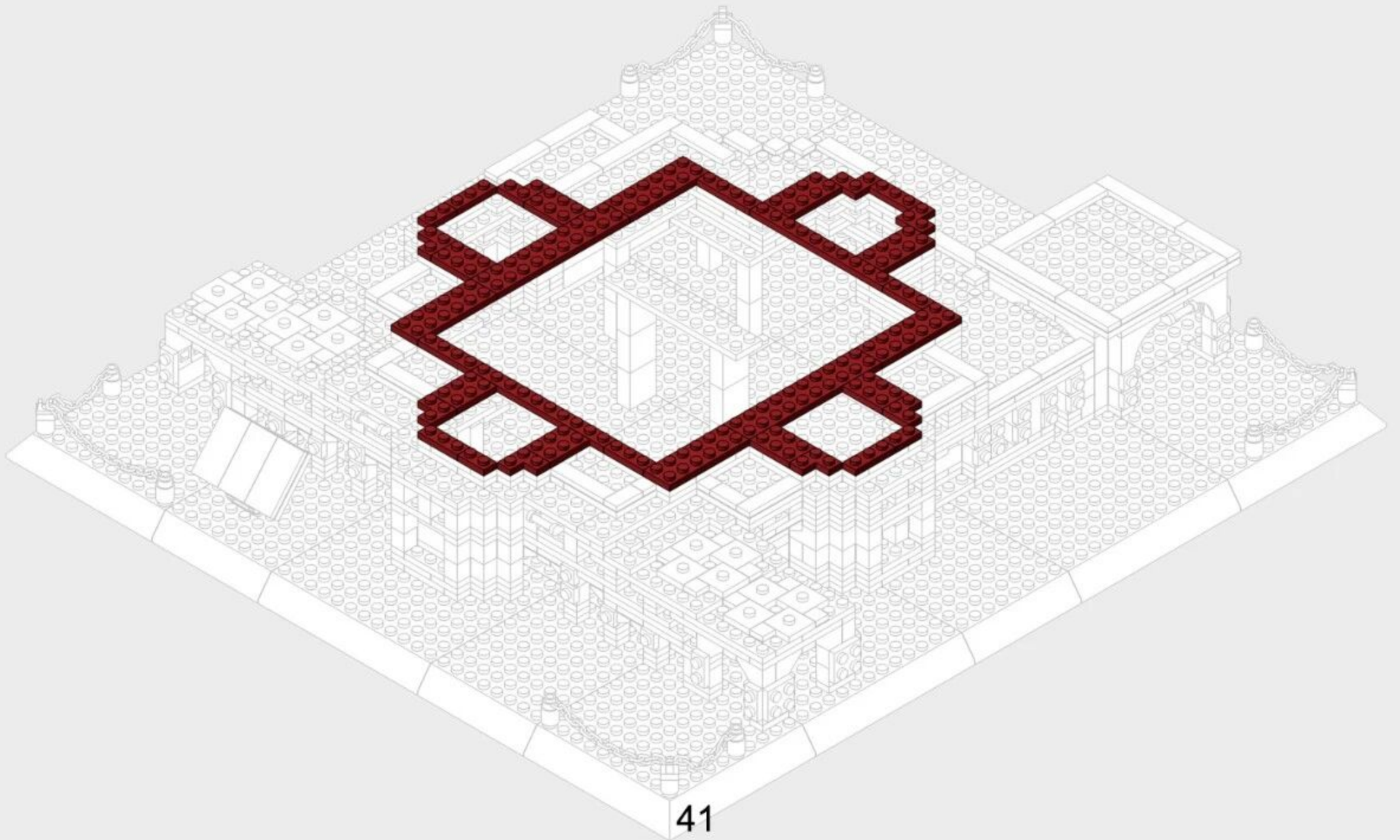

25

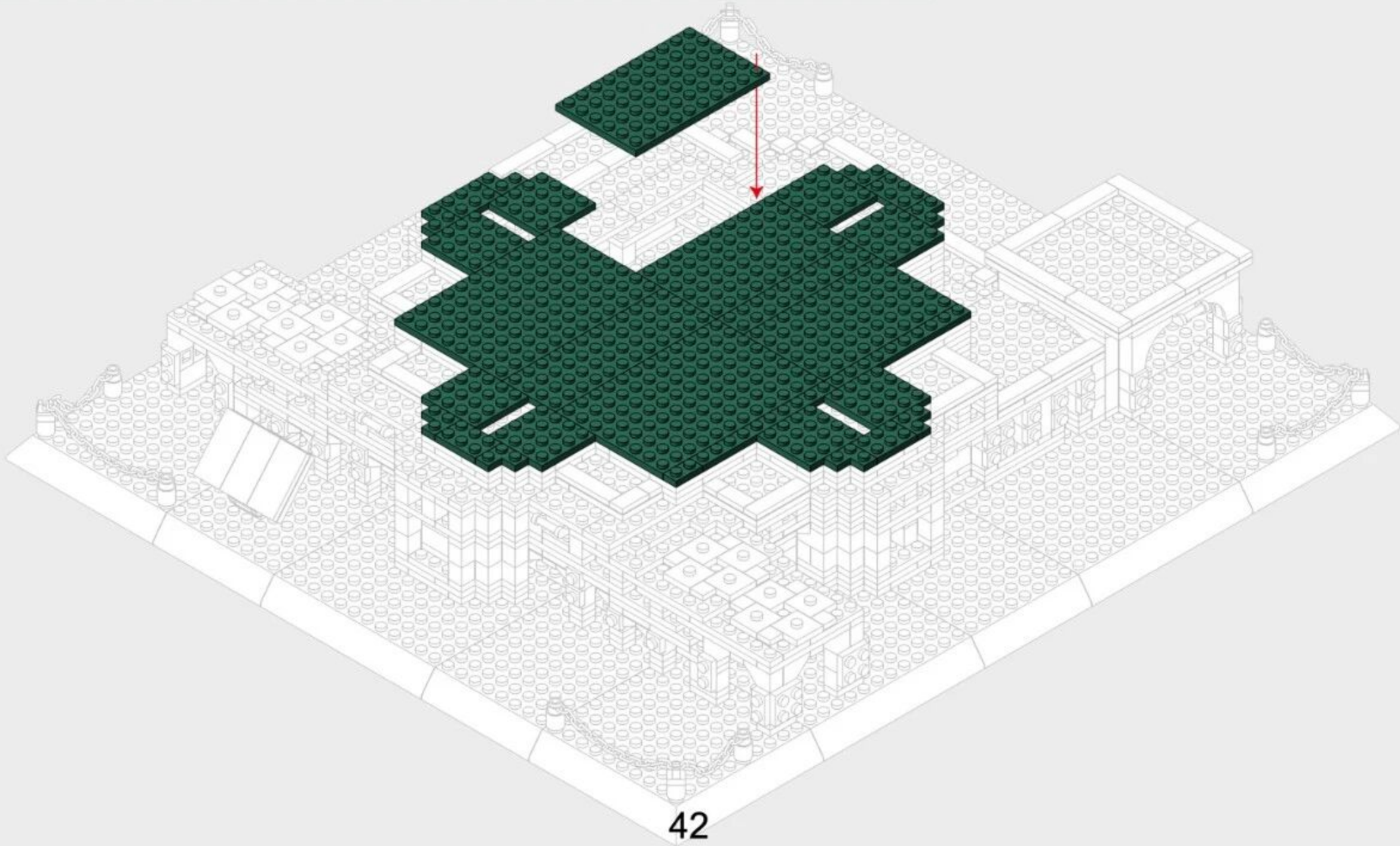
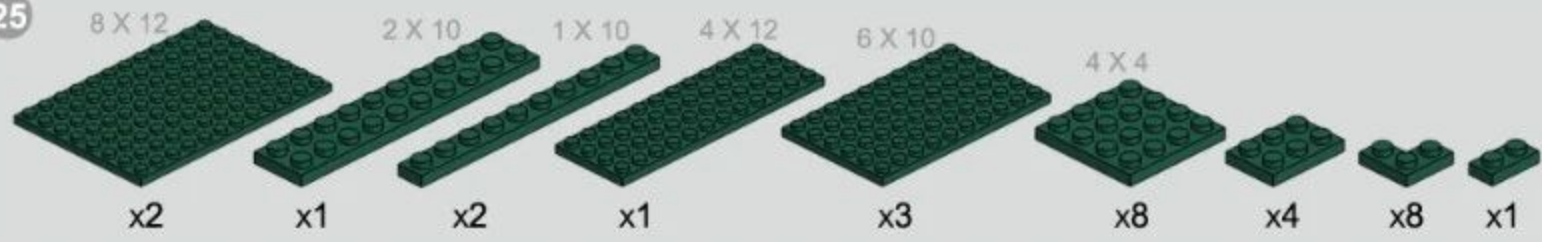

26



x16



x4



x4



x16



x4



x4



x4

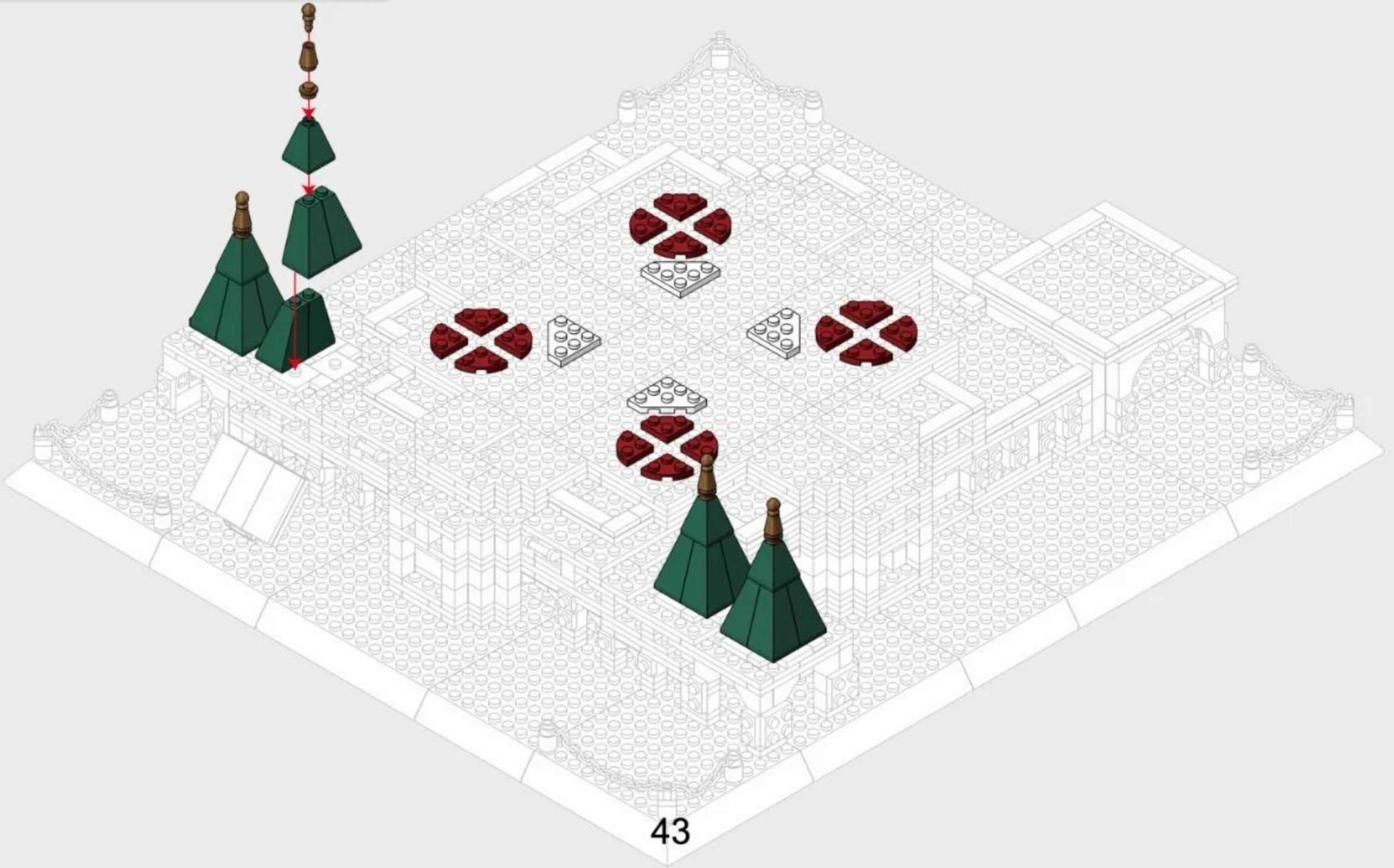

43

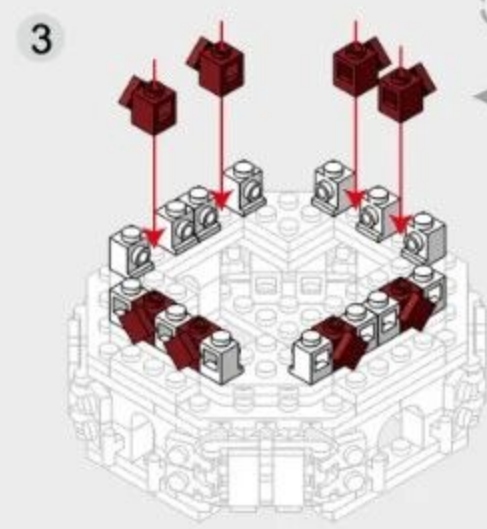
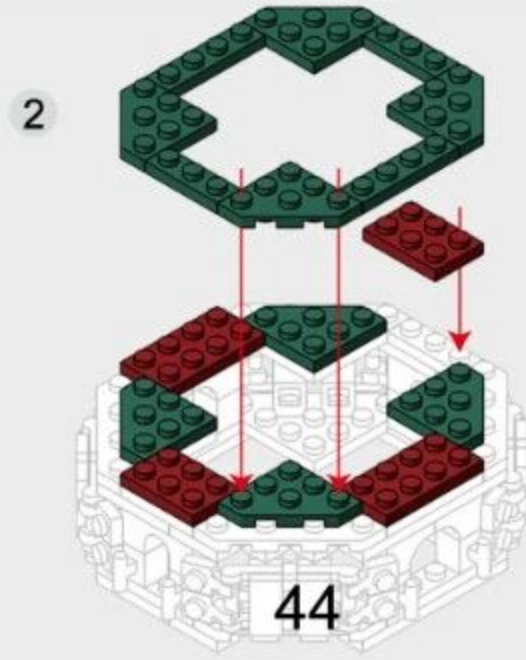
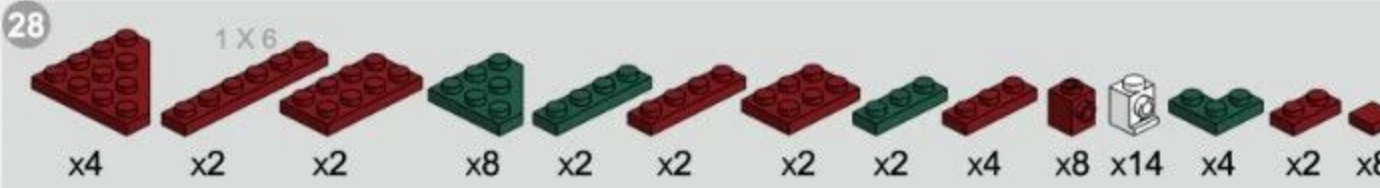
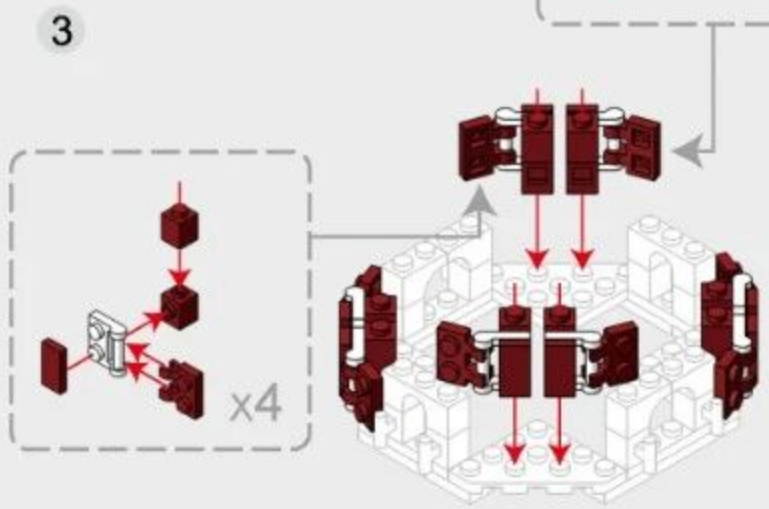
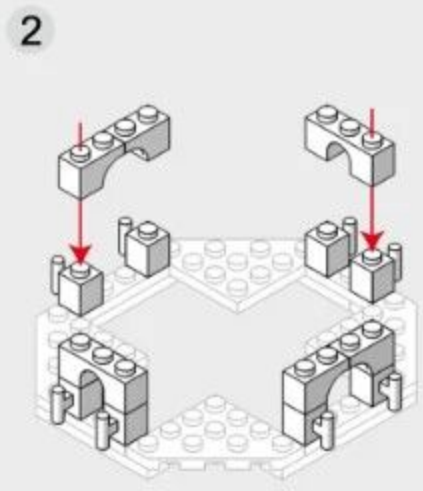
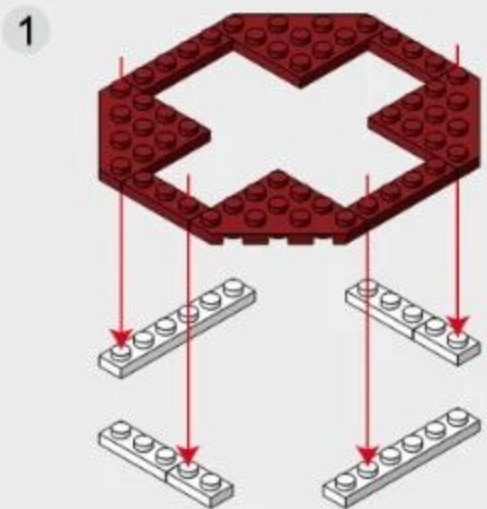
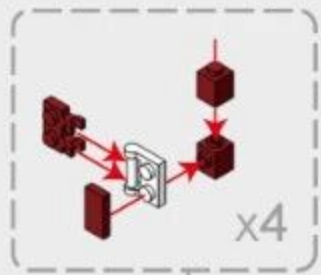
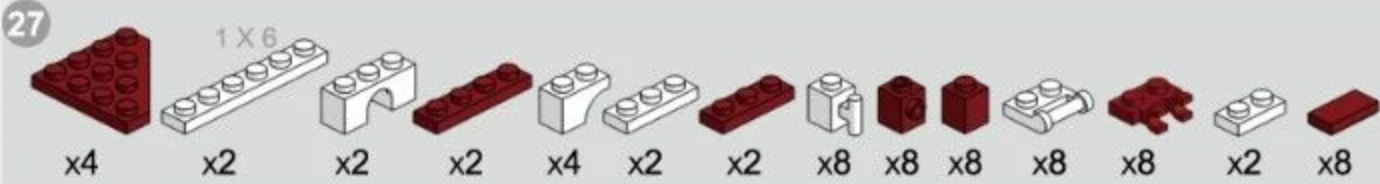

29

1 X 6

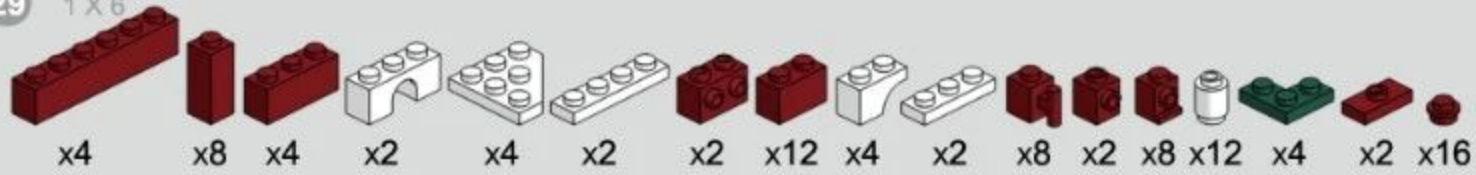

1

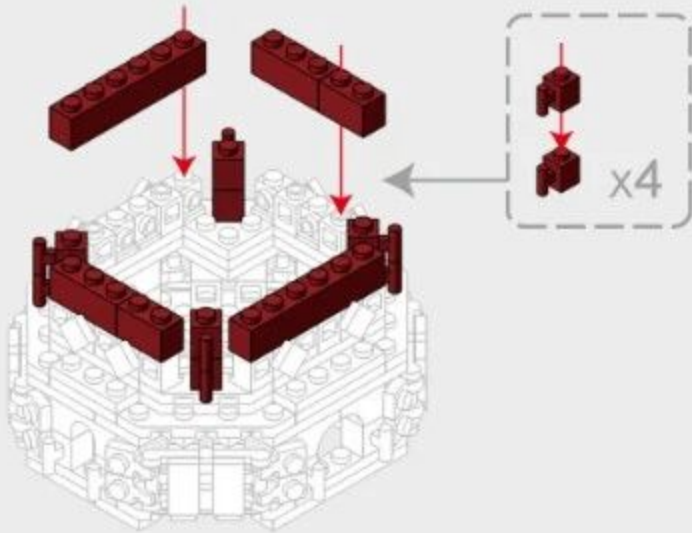

2

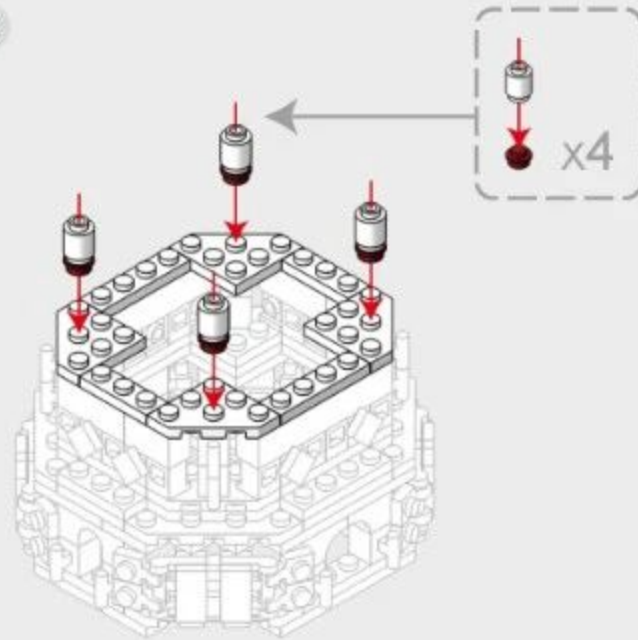

3

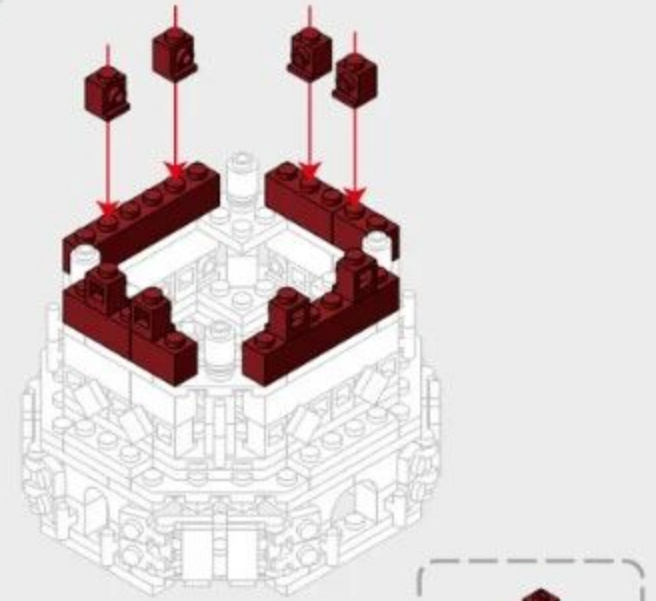

4

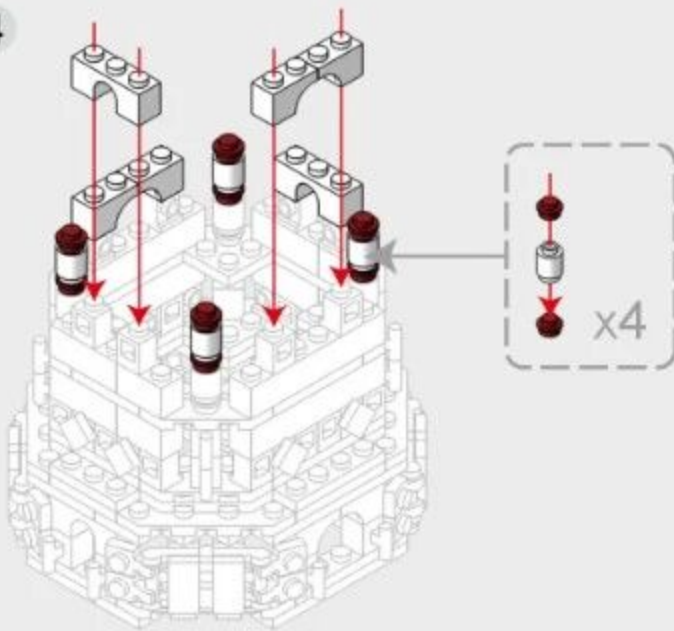

5

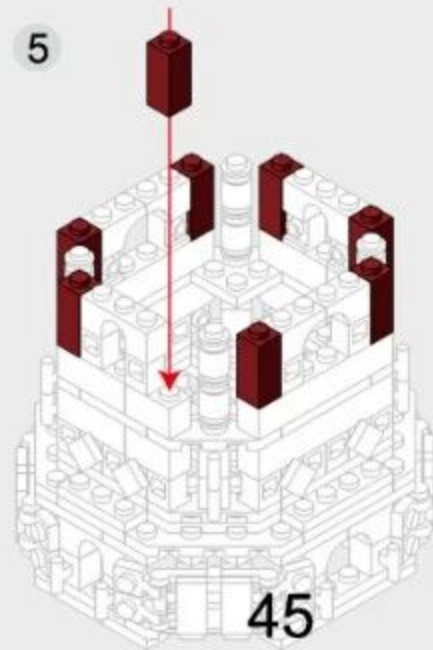

6

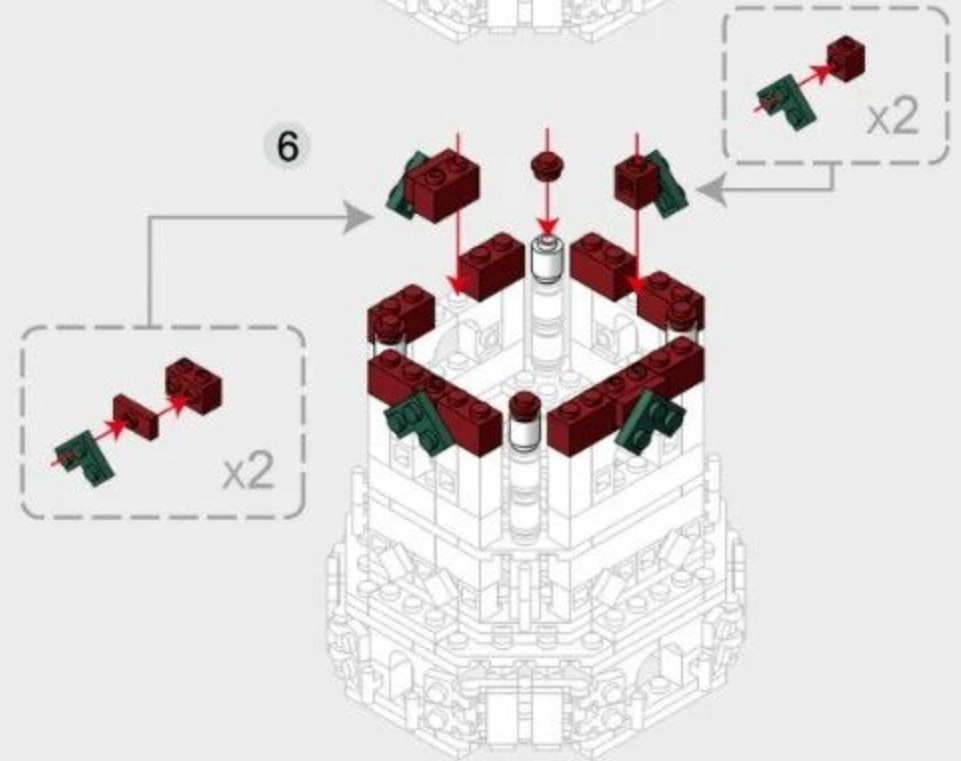

- 30
- x8
 - 1 x 6
 - x6
 - x2
 - x2
 - x4
 - x2
 - x4
 - x6
 - x4
 - x2
 - x4
 - x8
 - x6
 - x4
 - x6

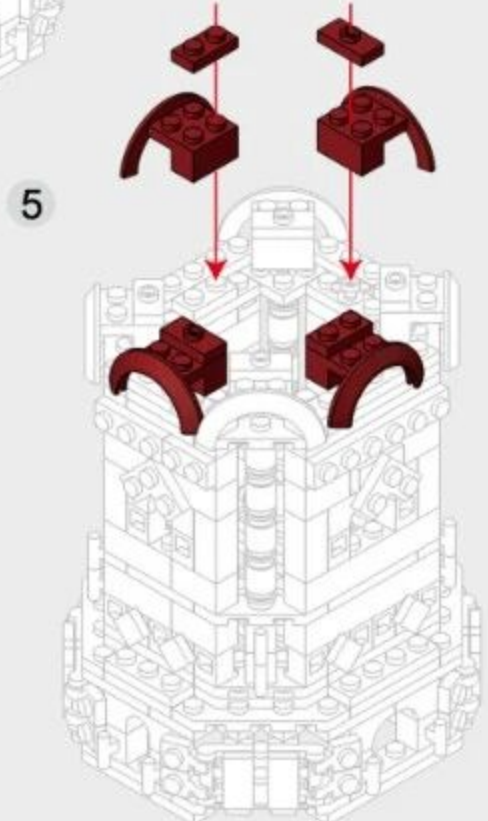
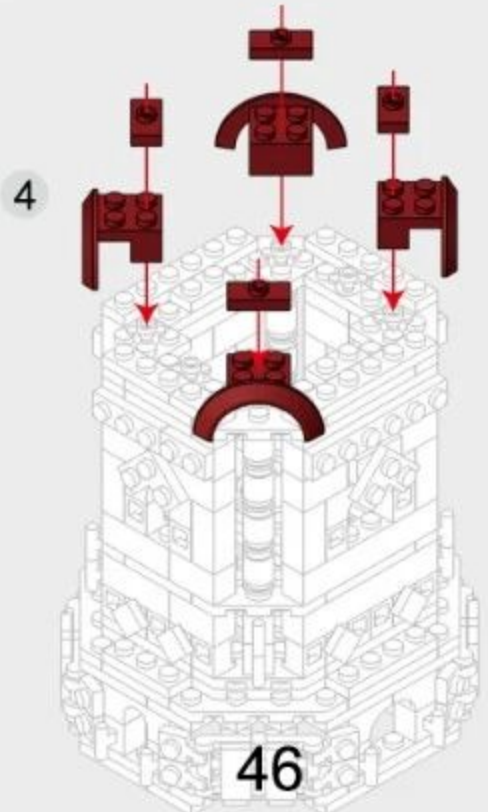
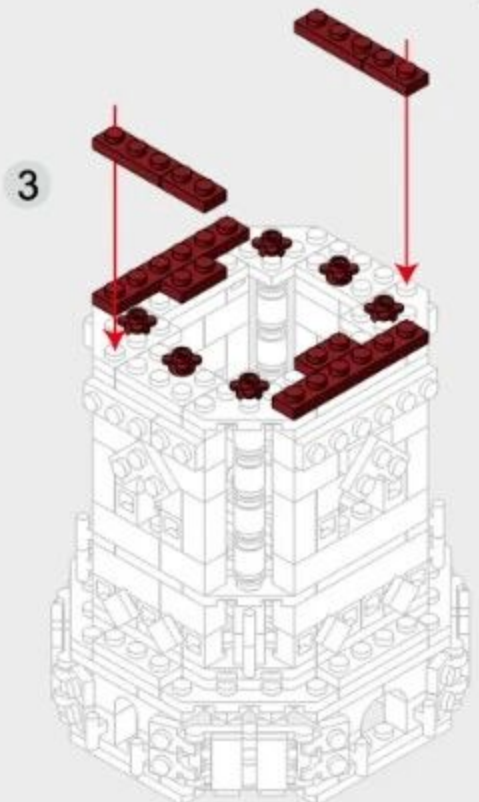
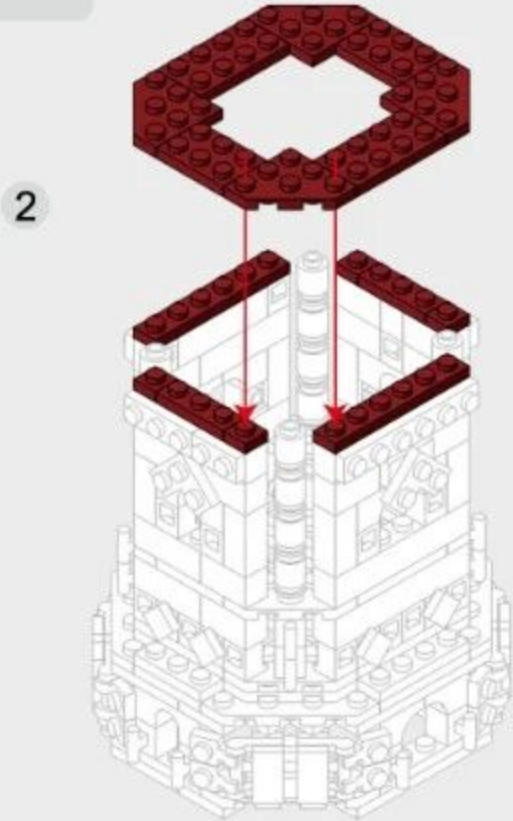
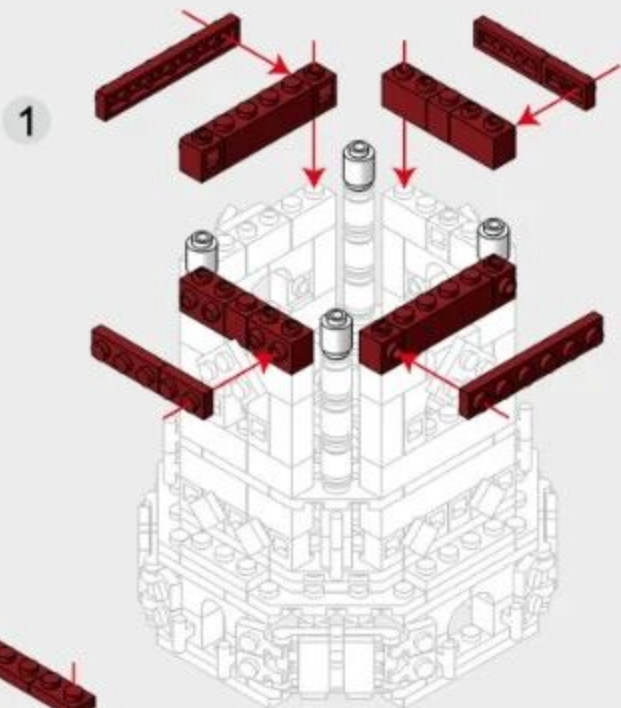

31

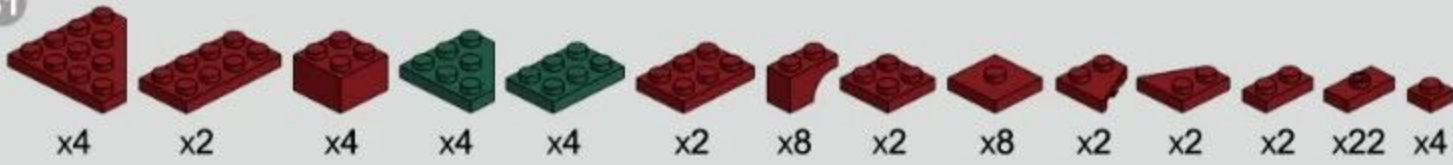

1

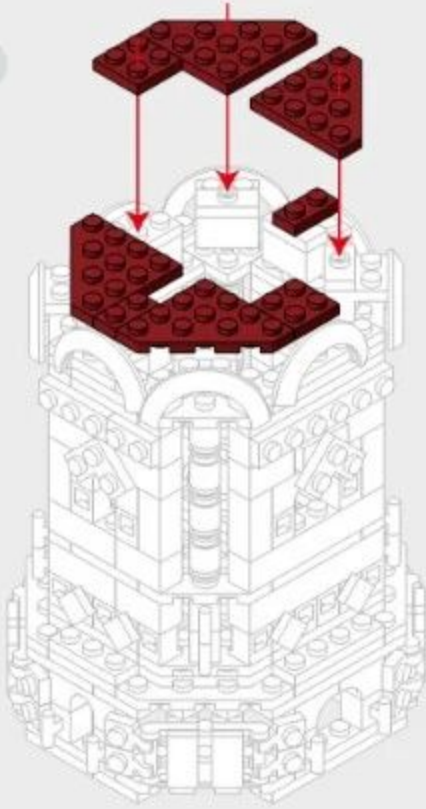

2

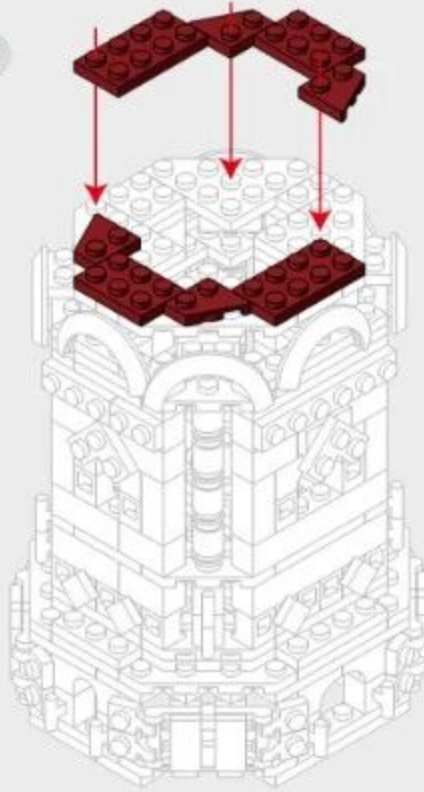

3

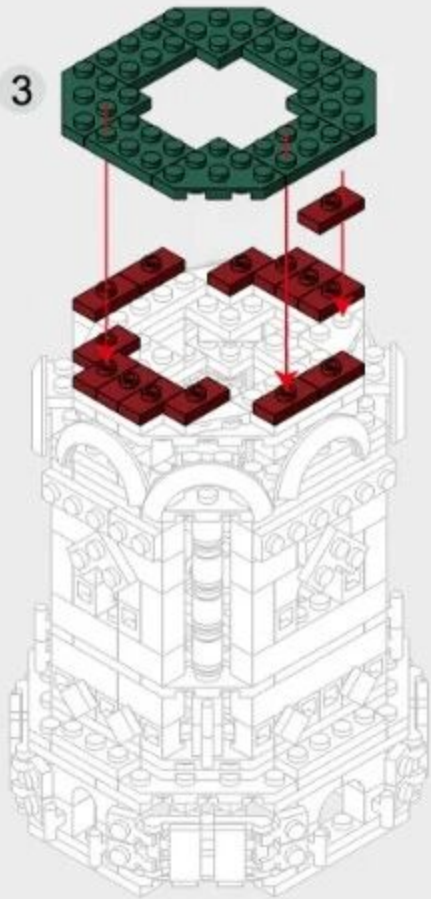

4

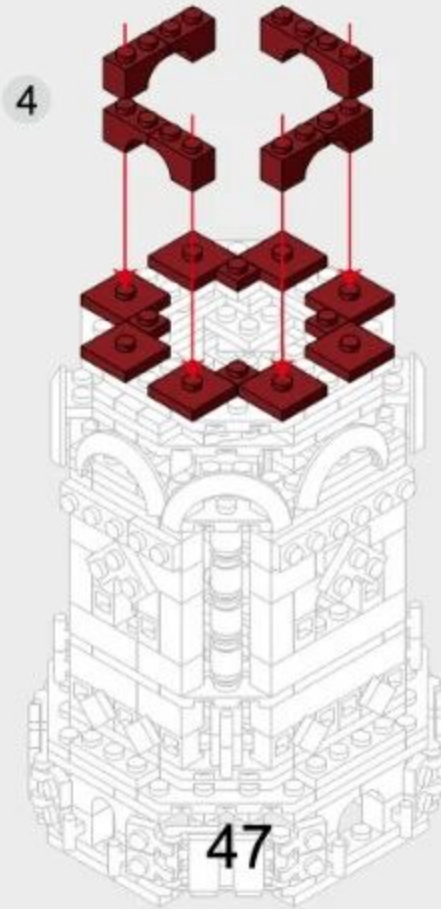

5

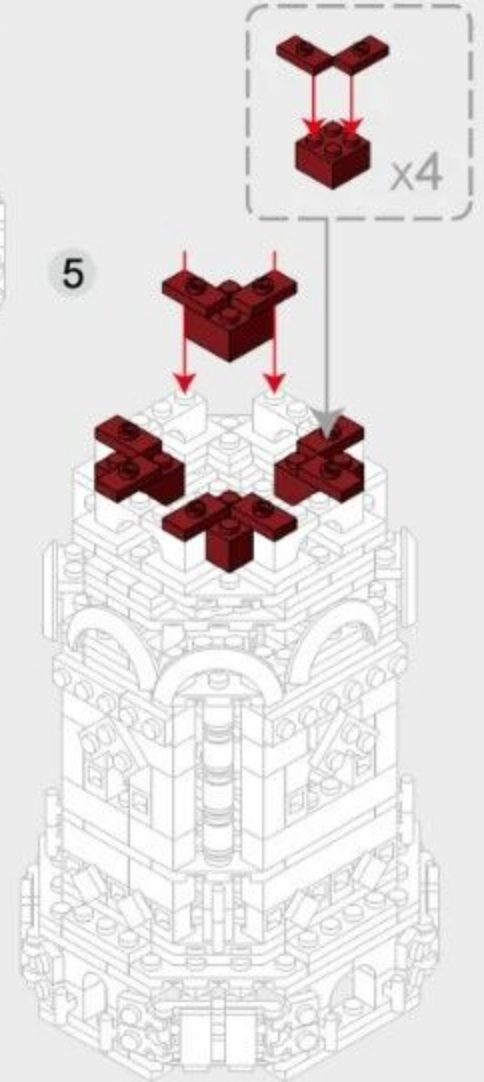

32

4 X 4

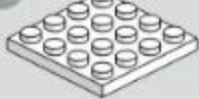

x1



x4



x2



x8



x4



x8



x8



x8



x8



x4



x4



x4



x4

1

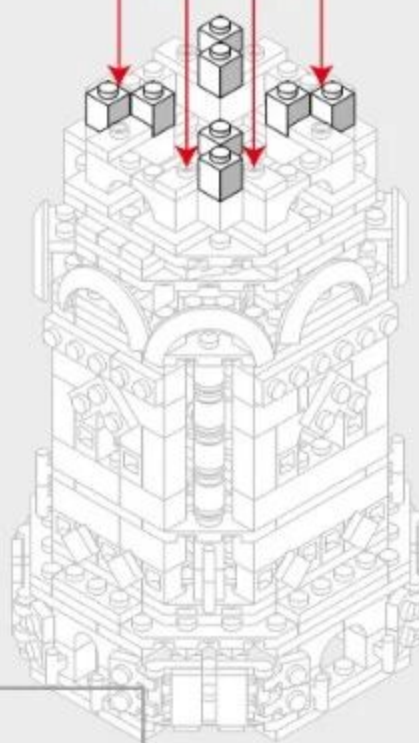

2

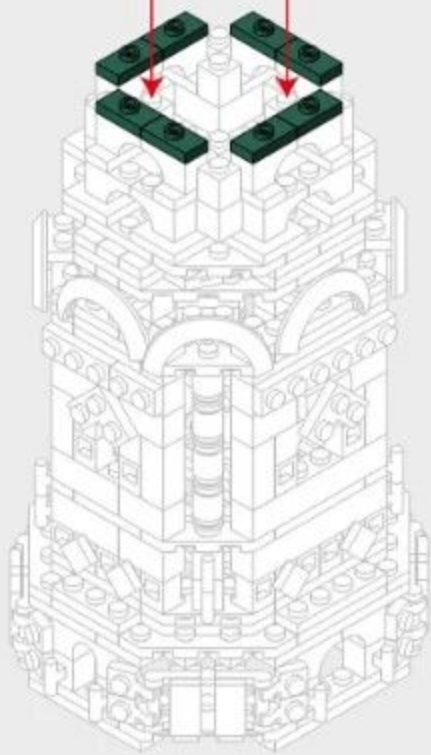
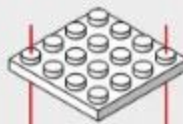

3

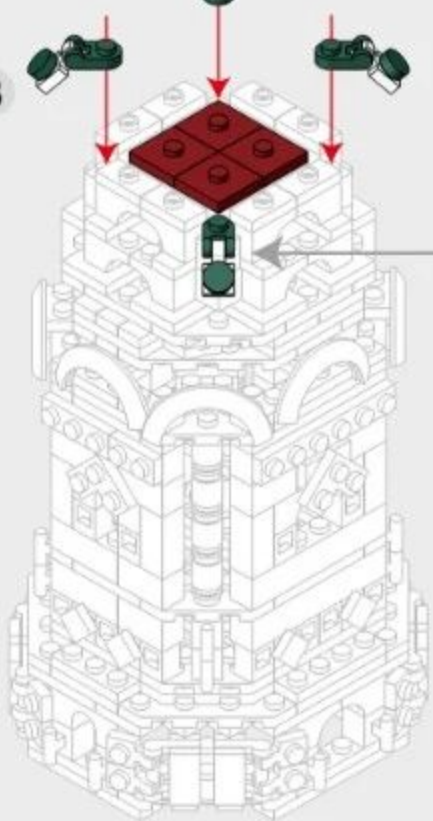

4

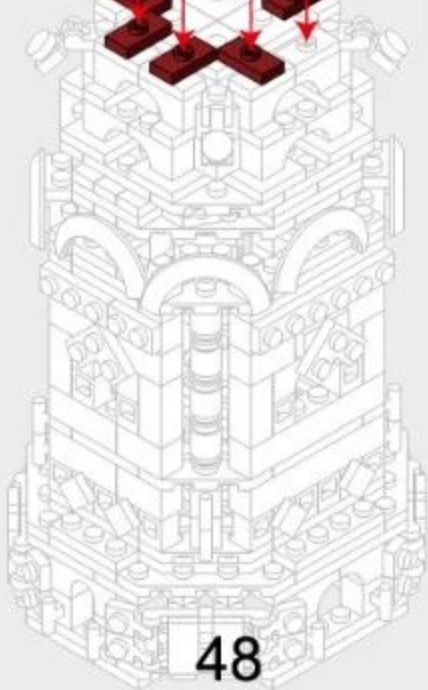
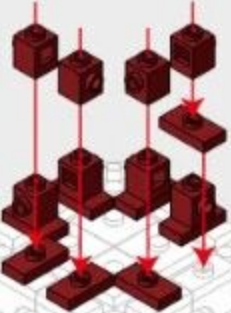

5

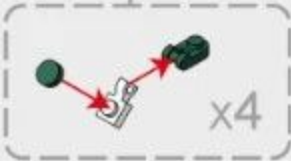
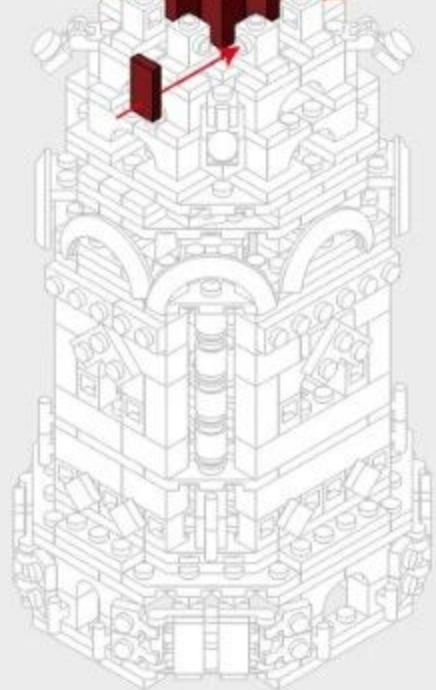
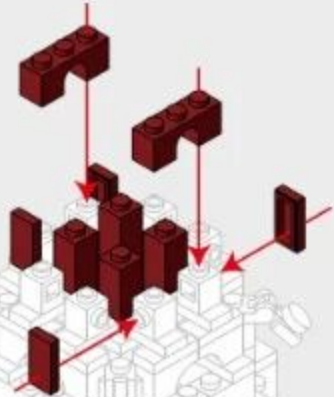

x4

33

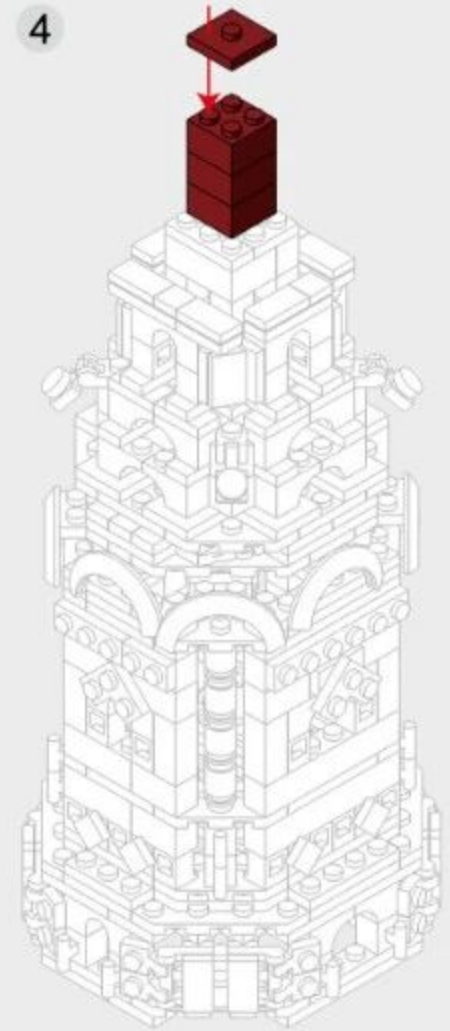
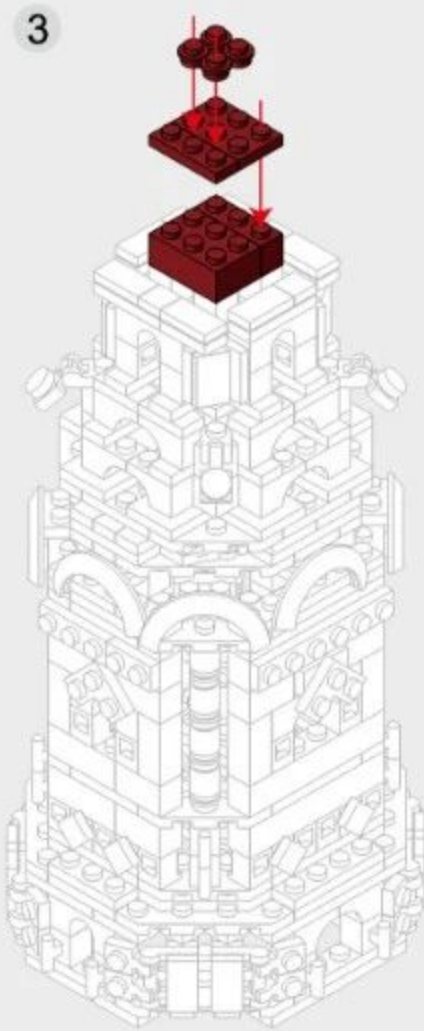
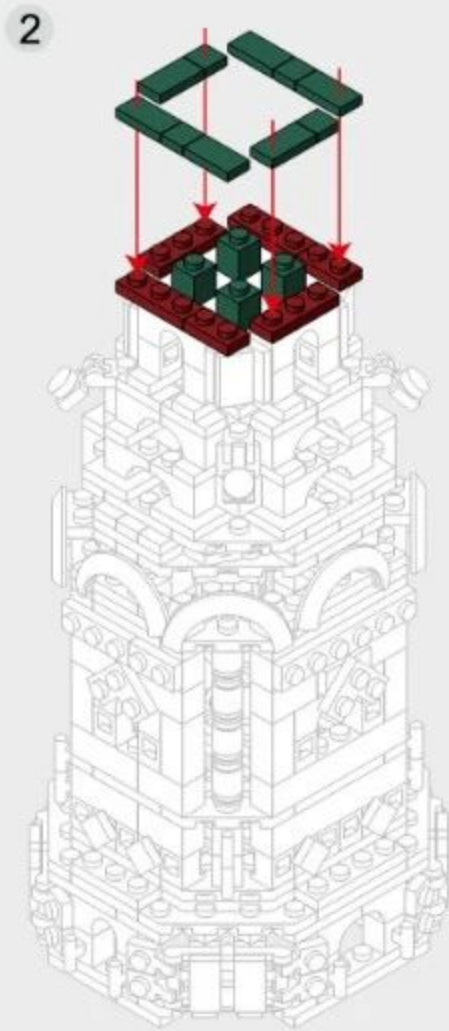
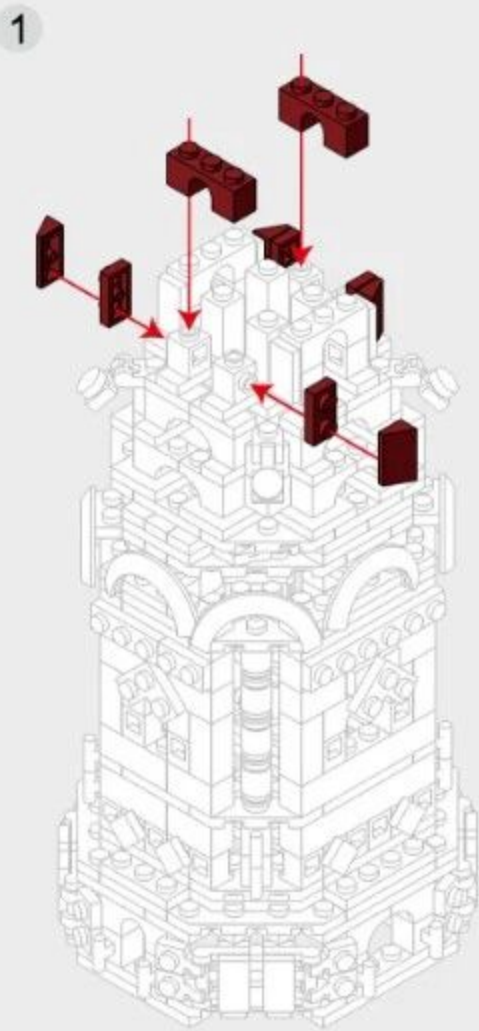
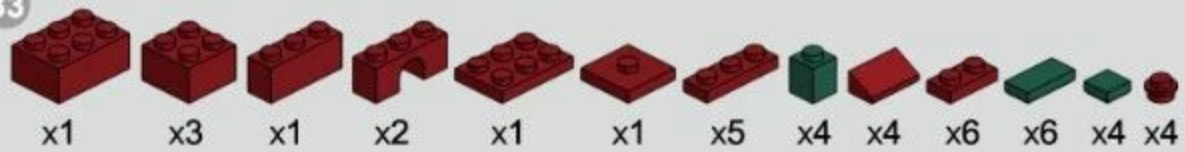

34

- x1
- x4
- x4
- x4
- x1
- x1
- x4
- x1
- x4
- x1
- x1
- x4
- x4
- x4
- x4
- x8
- x8

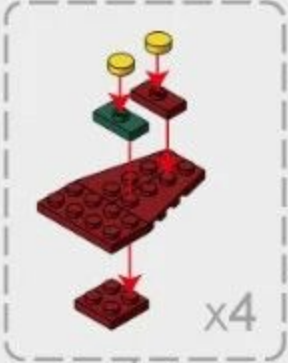
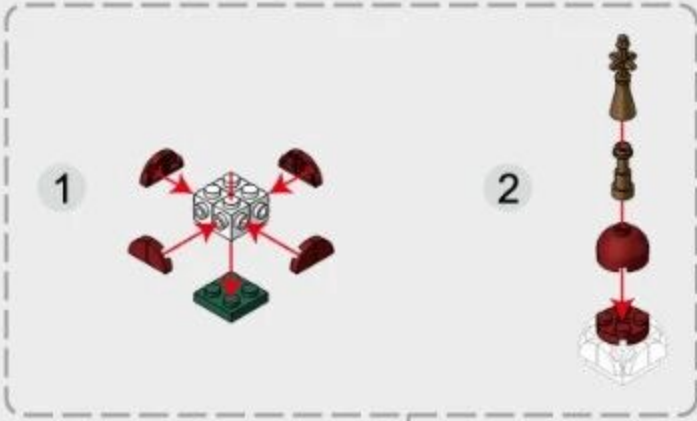

1

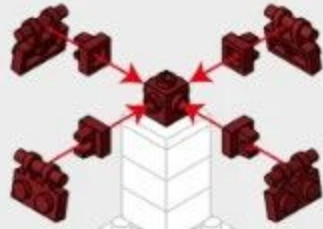

2

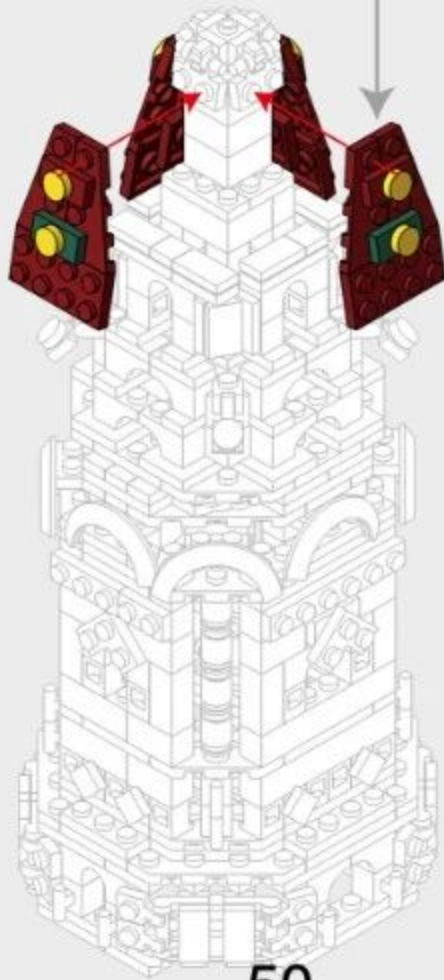

3

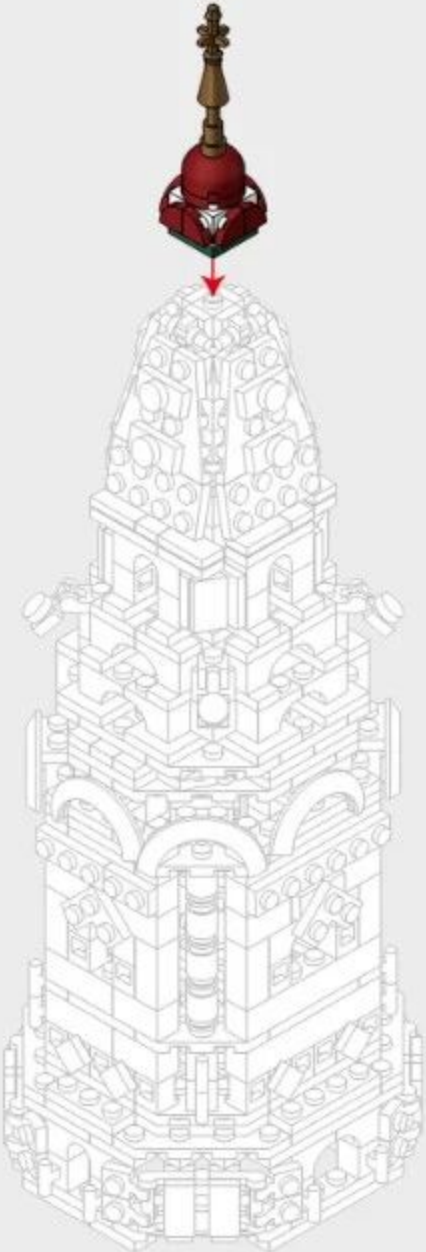

35

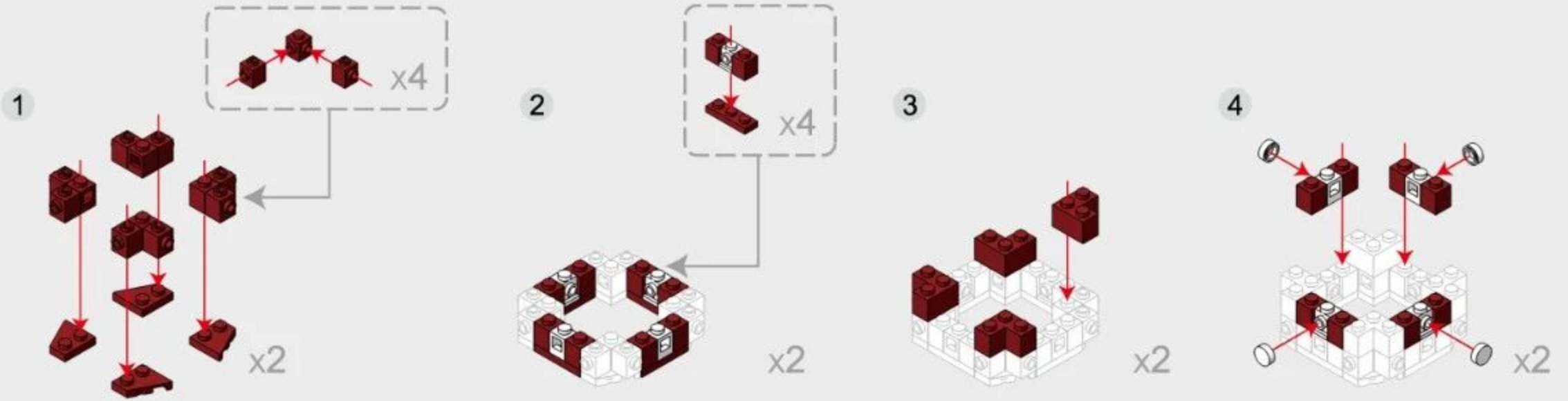

36

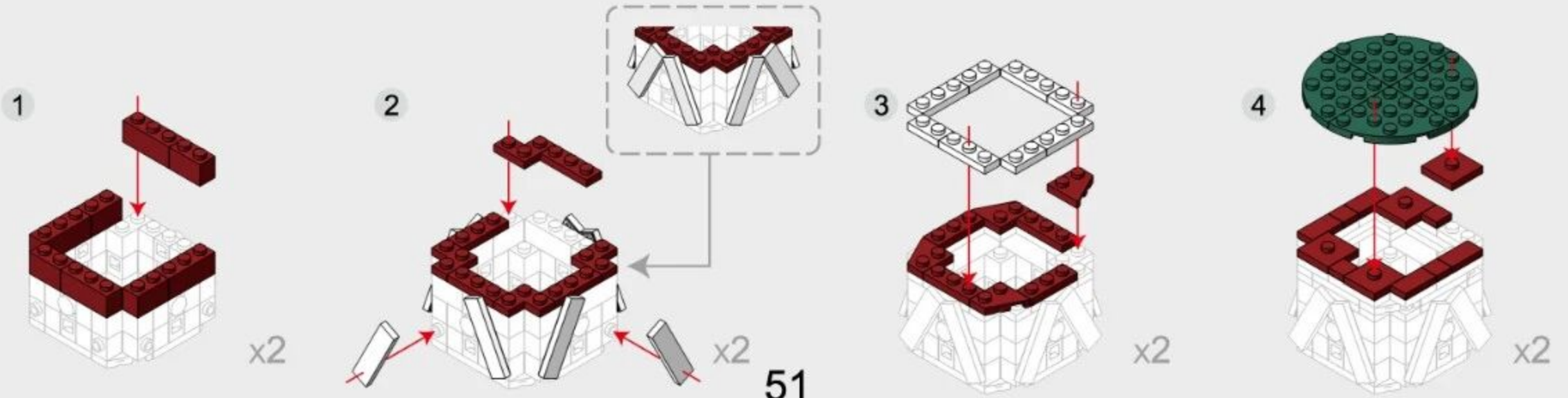
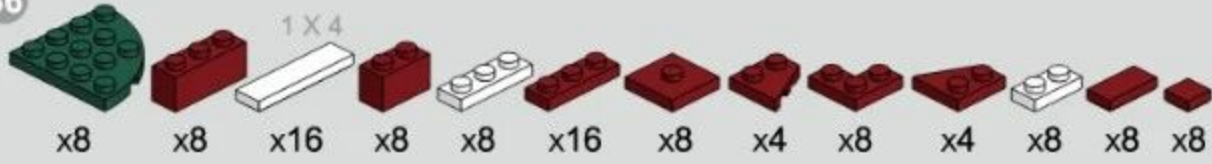

37

- x8 [Red 1x4 Technic Brick]
- x8 [Red 1x3 Technic Brick]
- x8 [Red 1x2 Technic Brick]
- x8 [White 1x2 Technic Brick]
- x8 [Red 1x2 Technic Brick]
- x16 [Green 1x2 Technic Brick]
- x8 [Green 1x2 Technic Brick]
- x8 [Red 1x2 Technic Brick]
- x8 [Red 1x2 Technic Brick]
- x8 [Green 1x2 Technic Brick]
- x8 [Green 1x2 Technic Brick]
- x16 [White 1x2 Technic Brick]
- x16 [Red 1x2 Technic Brick]
- x8 [Green 1x2 Technic Brick]
- x48 [Red 1x2 Technic Brick]

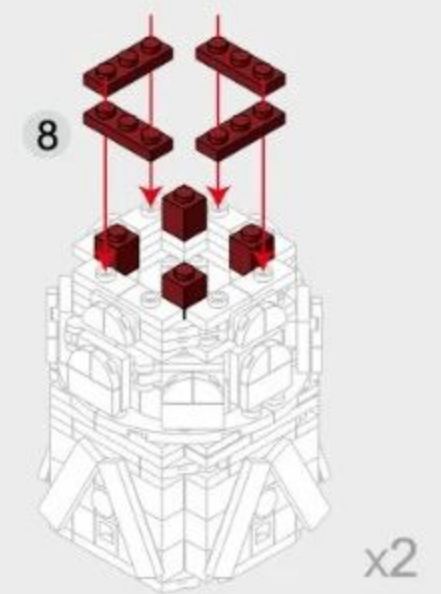
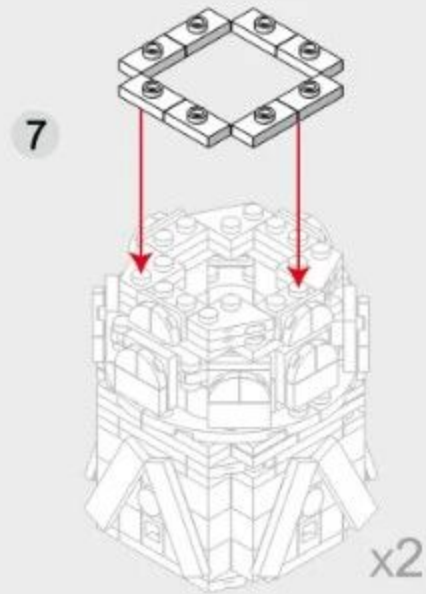
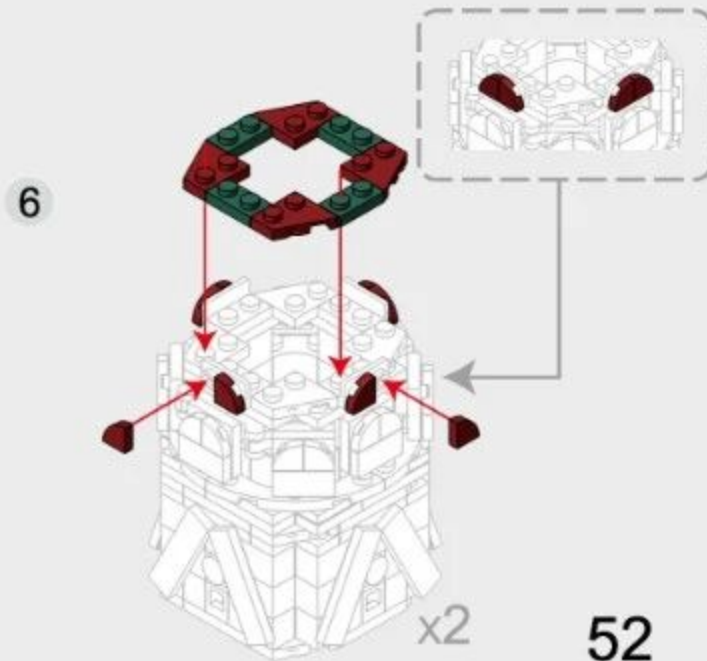
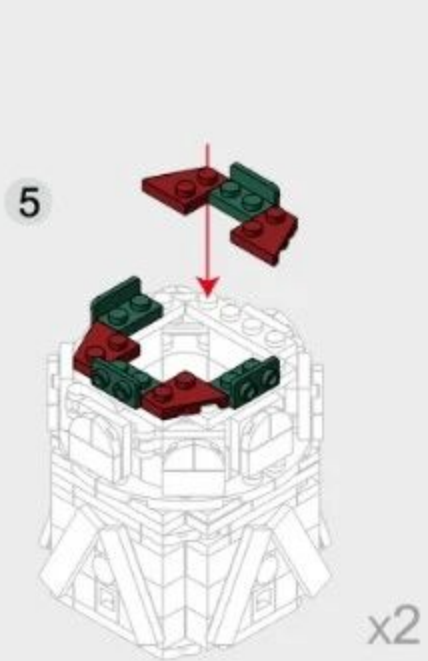
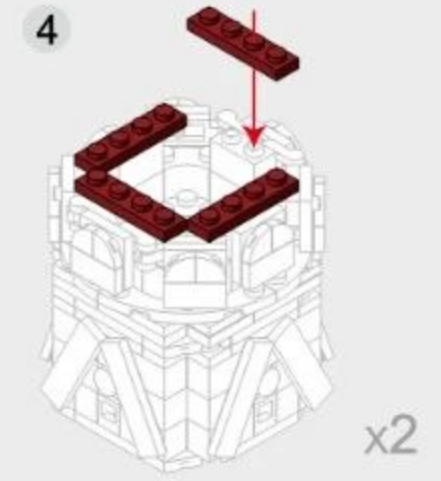
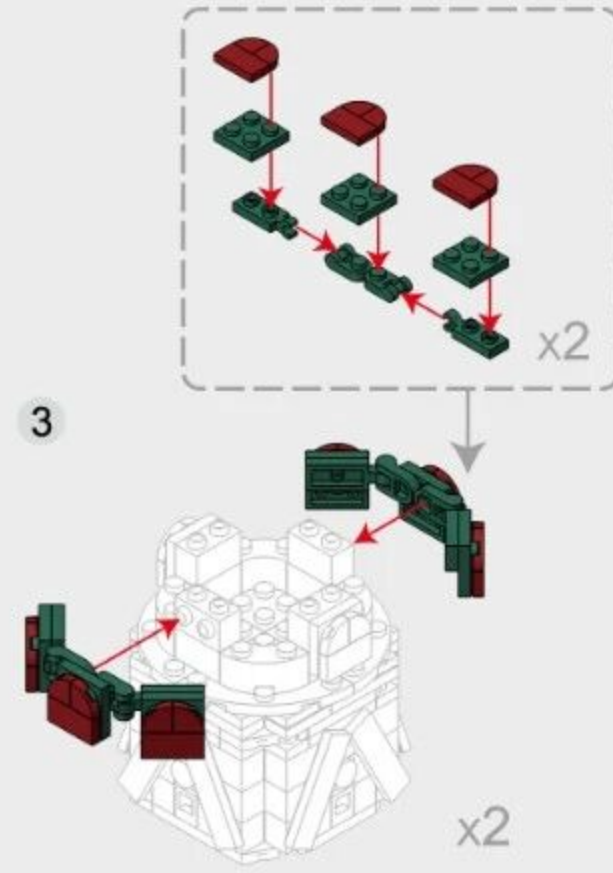
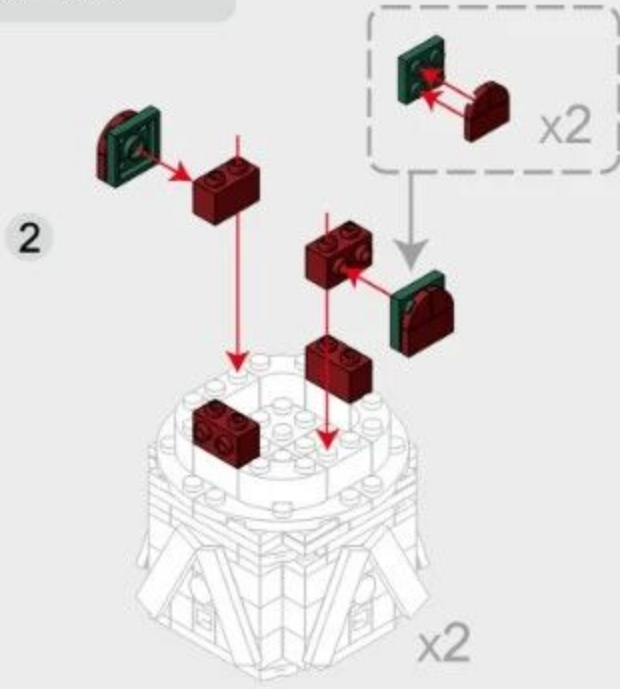
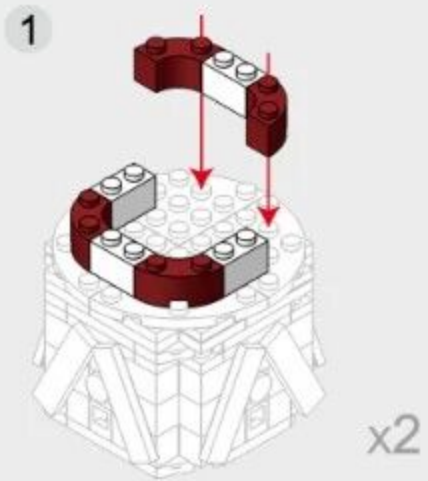

38

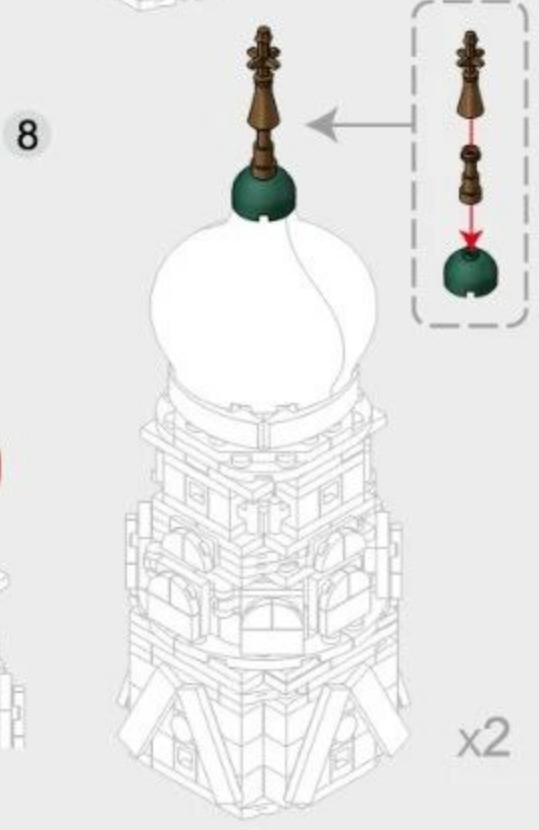
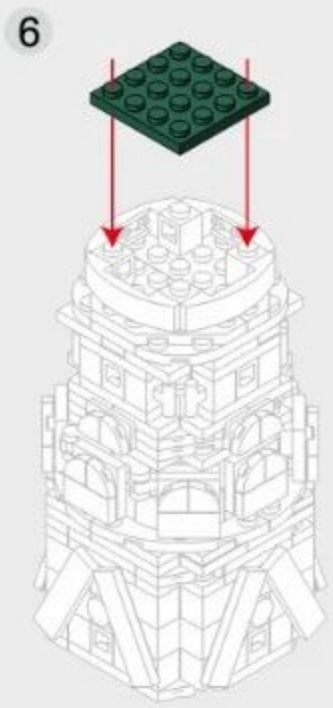
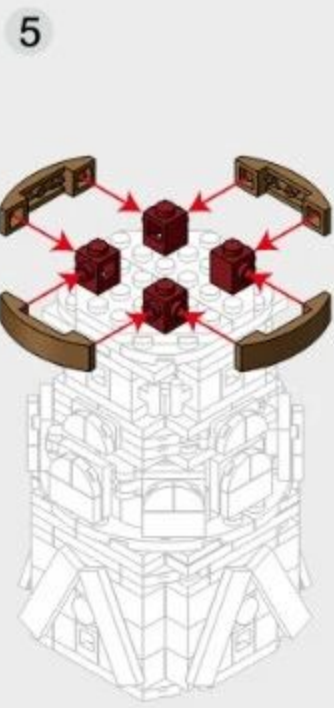
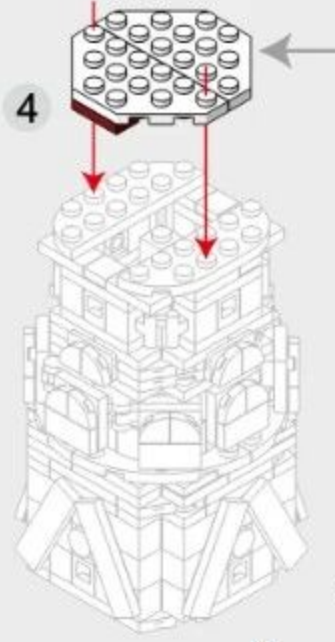
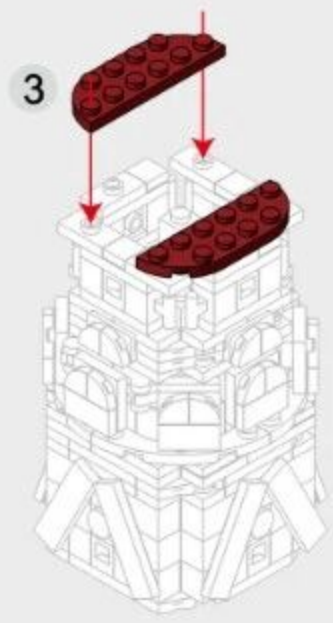
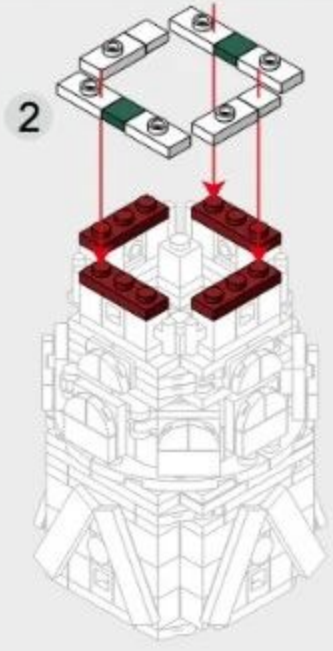
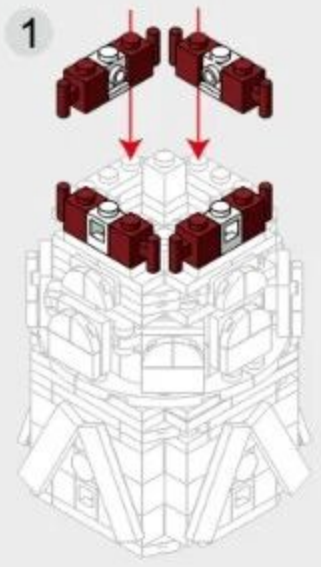
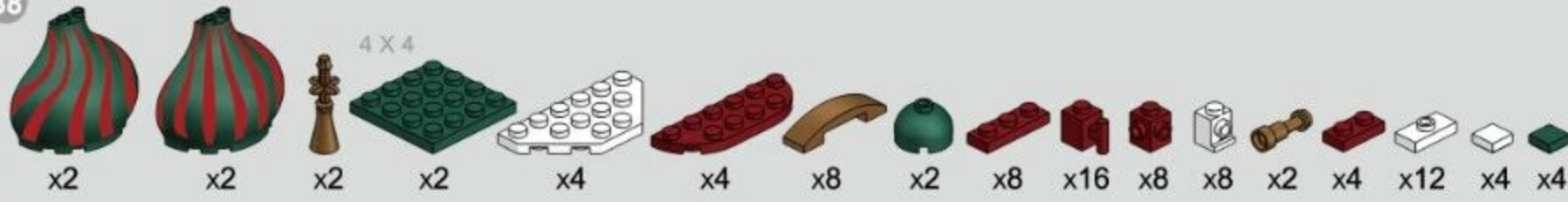

39

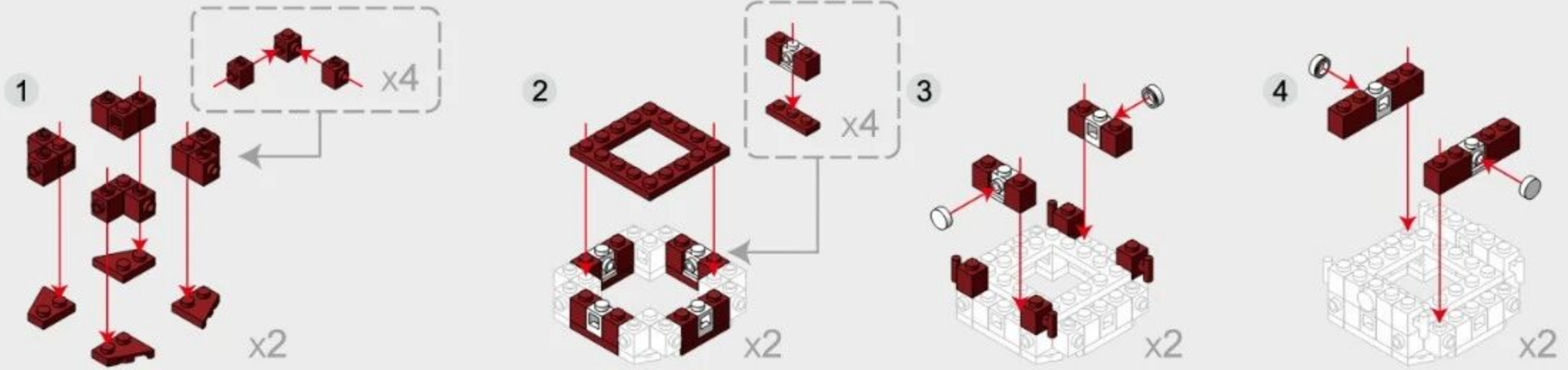

40

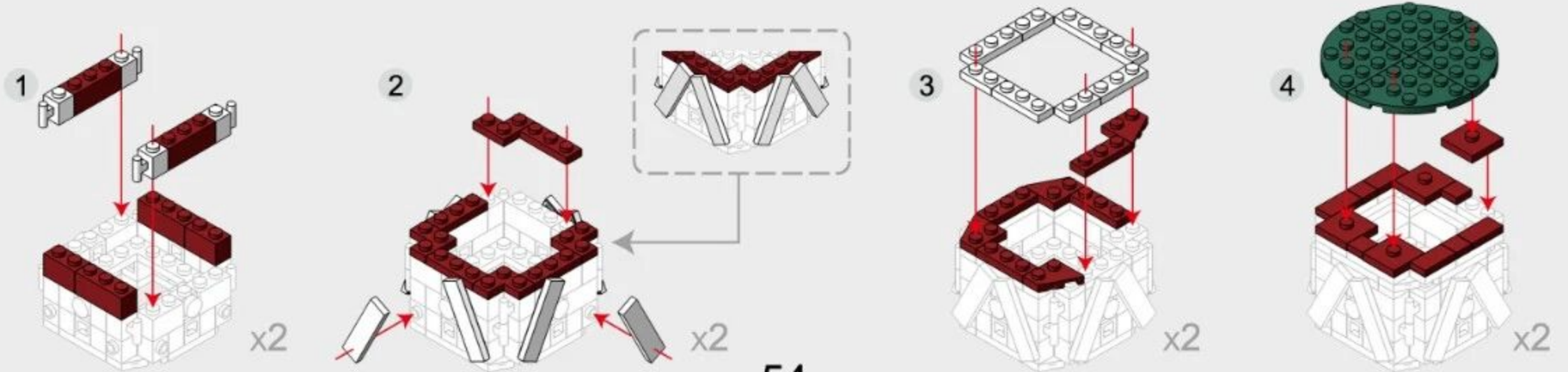

41

-  x8
-  x8
-  x8
-  x16
-  x8
-  x16
-  x8
-  x32

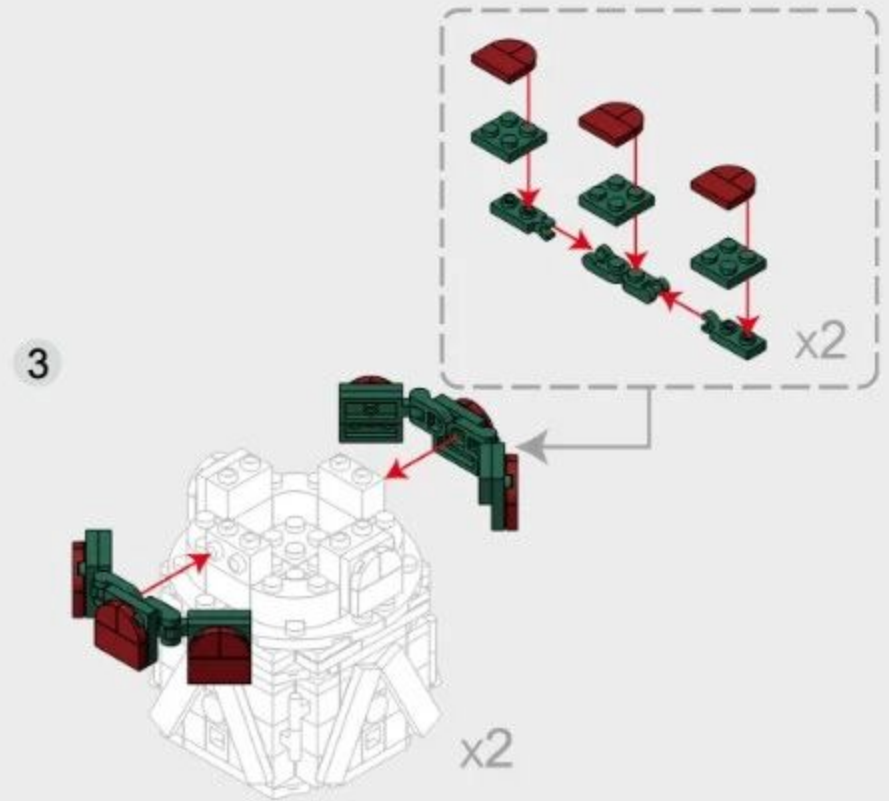
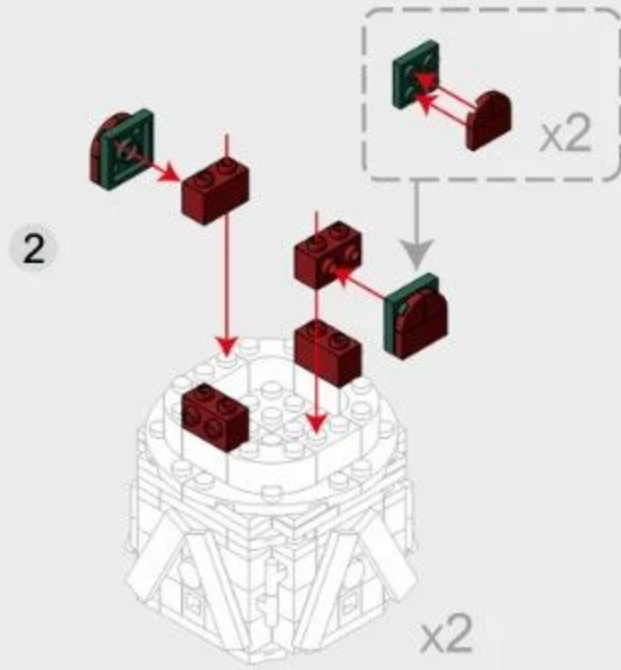
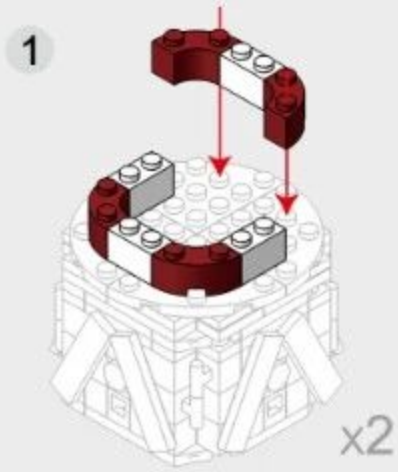

42

-  x8
-  x8
-  x8
-  x8
-  x8
-  x16
-  x16

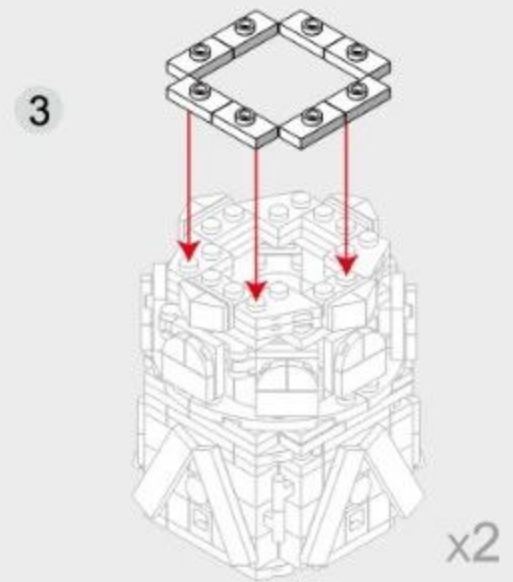
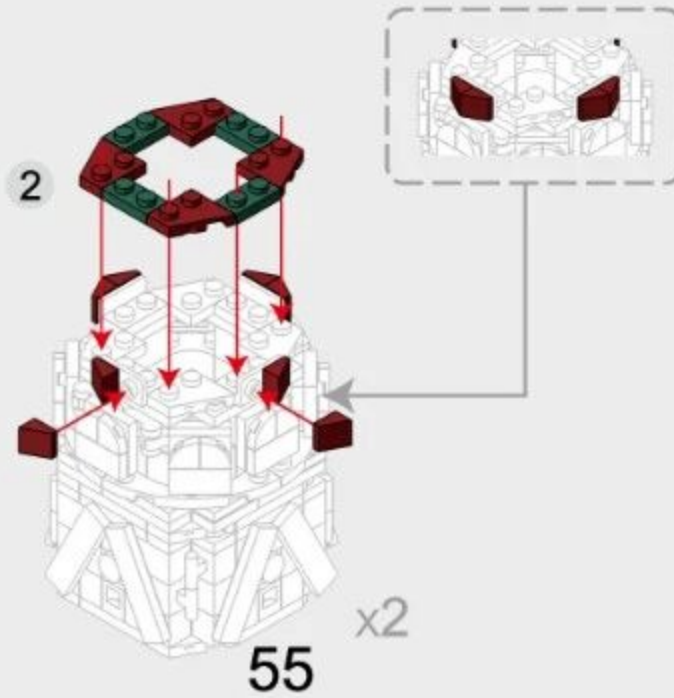
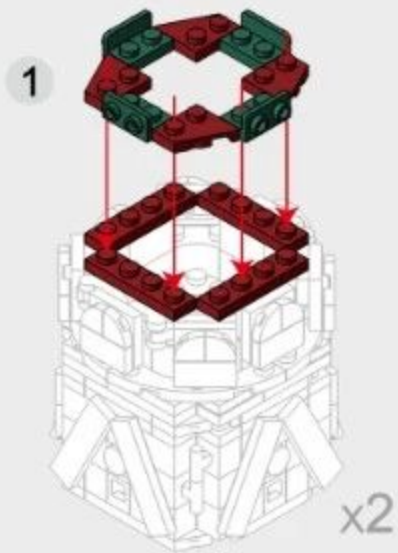

44



x2

4 X 4



x1



x1



x1



x1

1

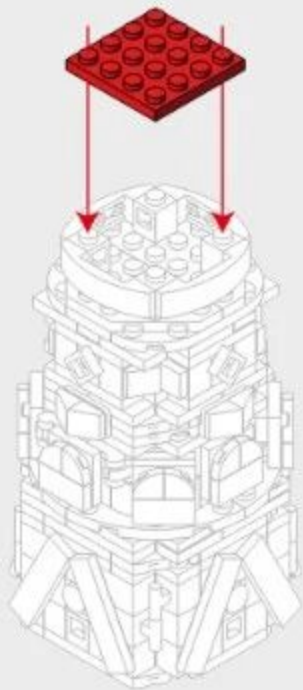

2



3

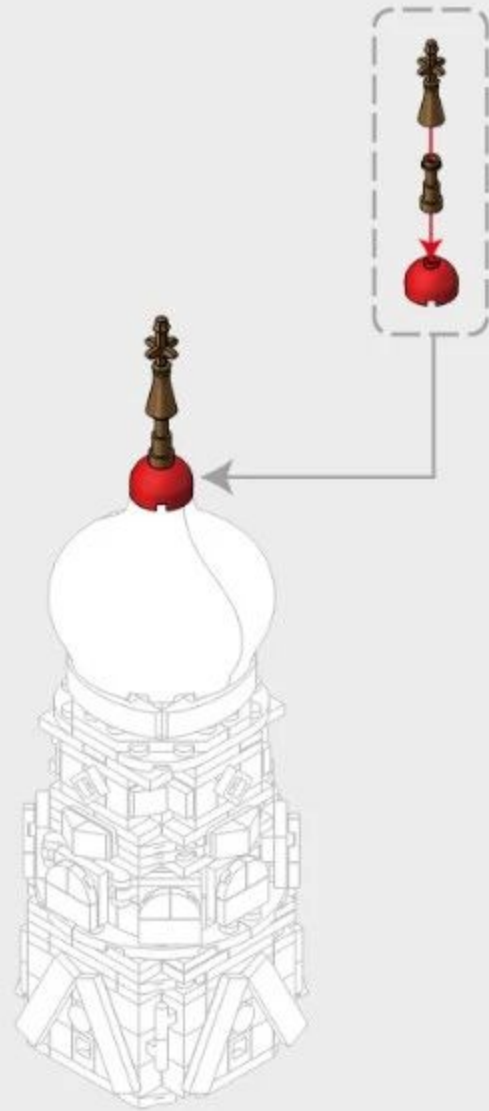

45



x2

4 X 4



x1



x1



x1



x1

1

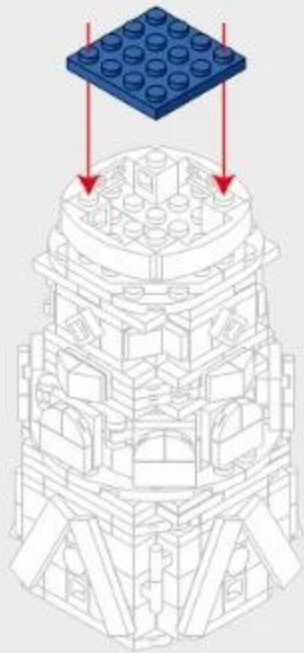

2



3

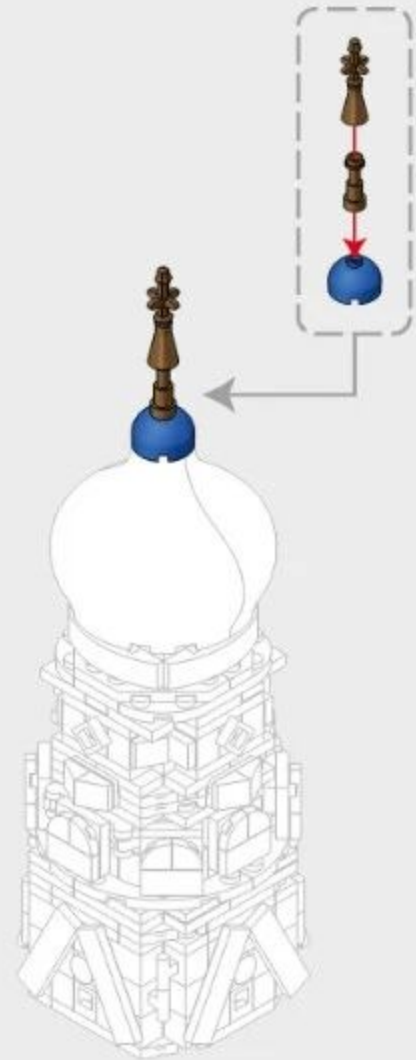

46

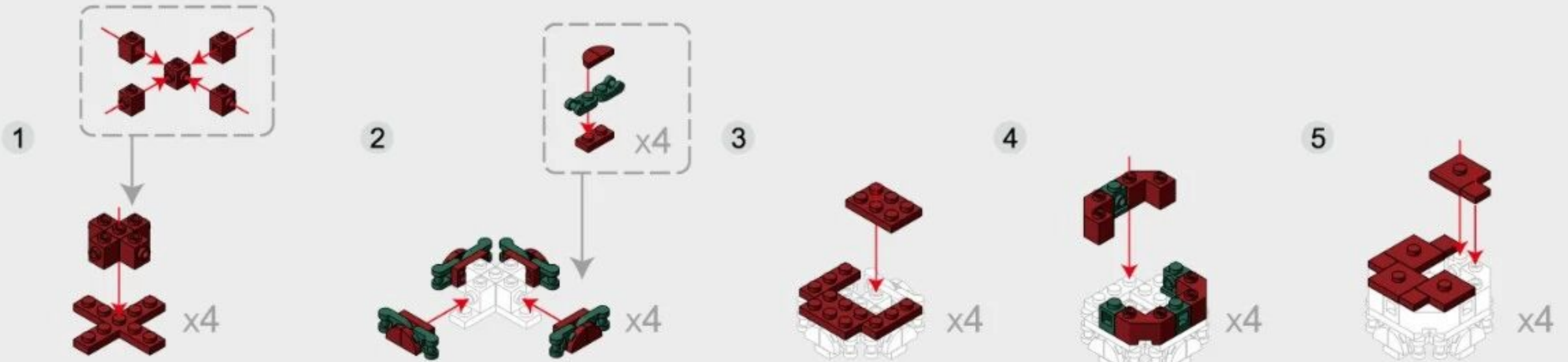

47

4x4

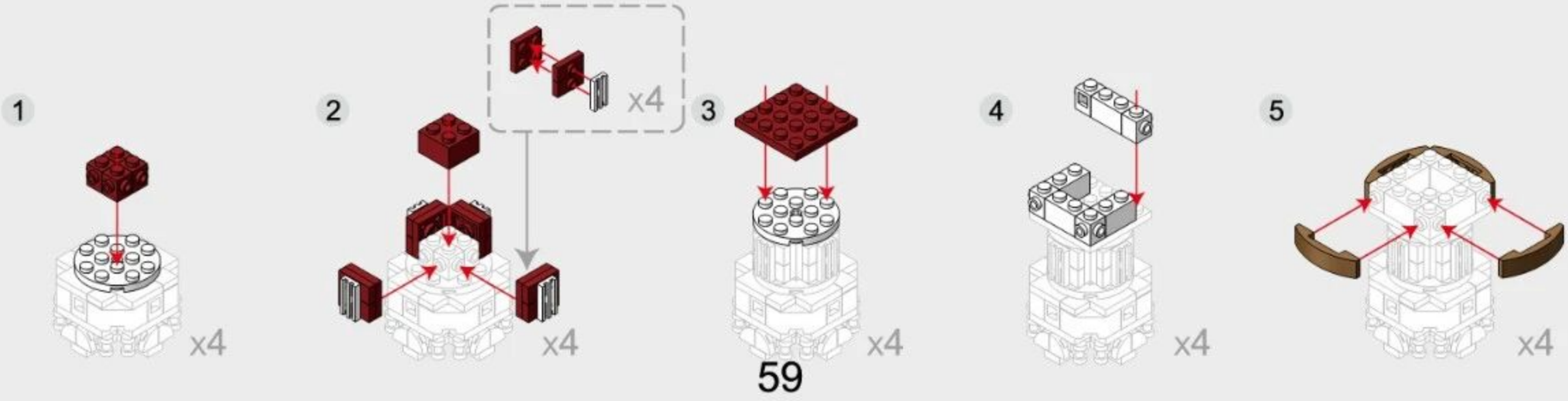

48



1

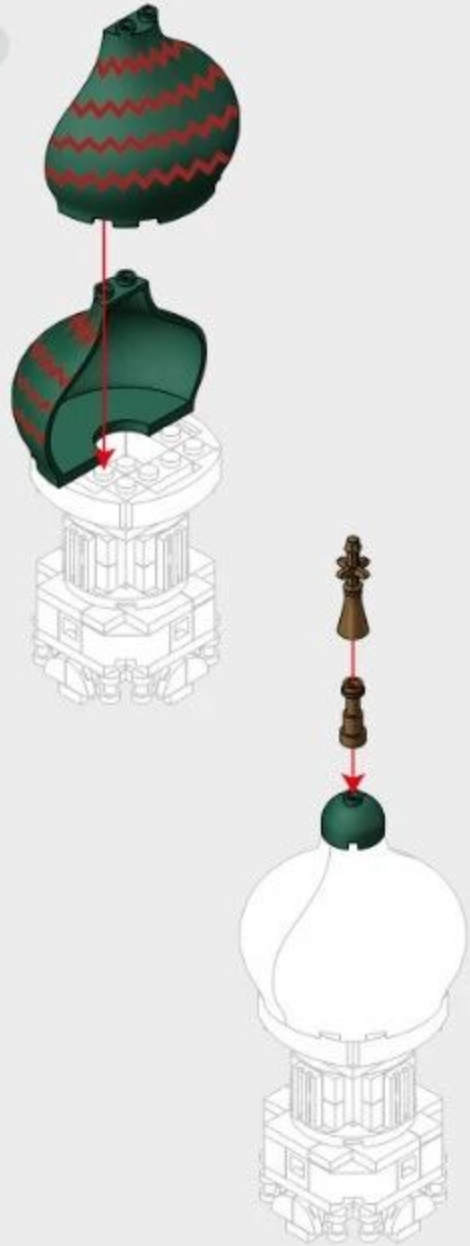

2

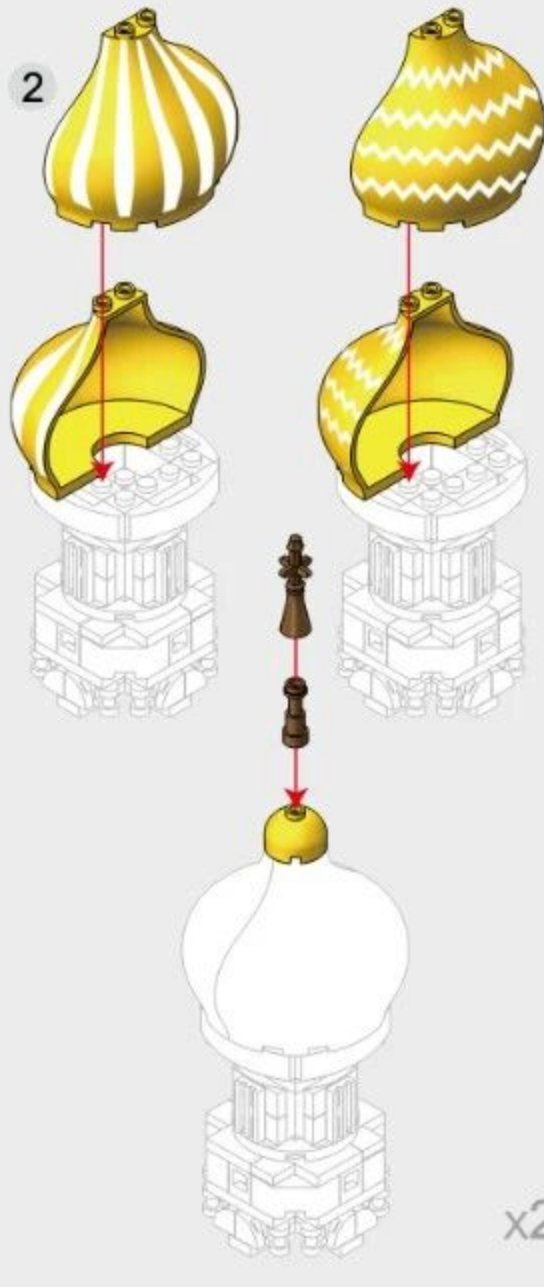

3

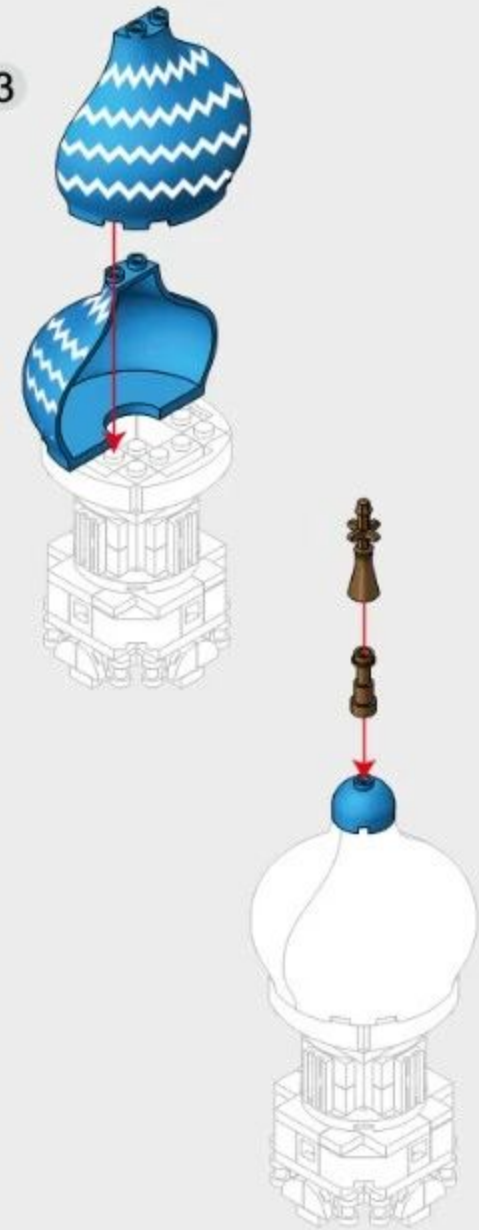

60

49

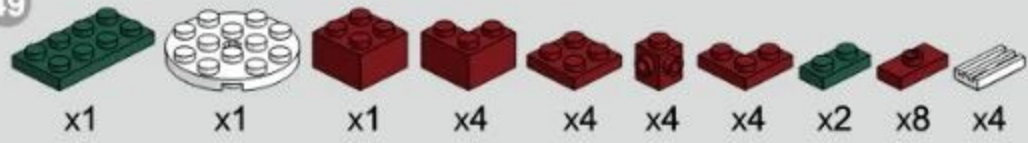

1

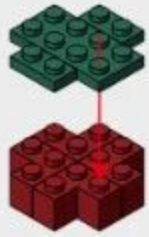

2



3



4

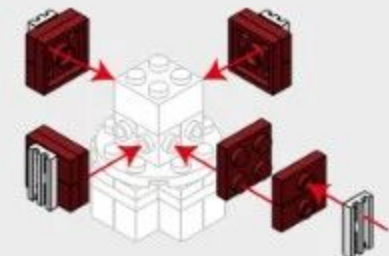

50

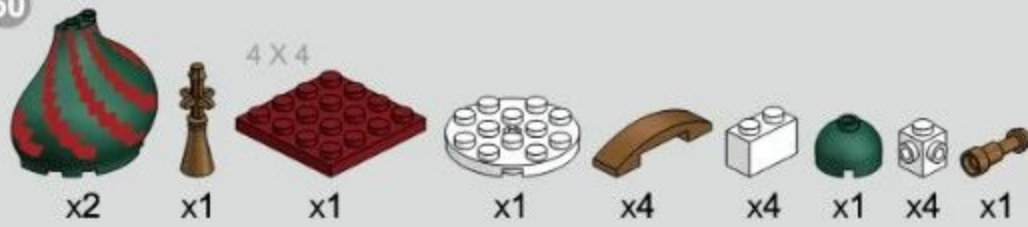

1



2

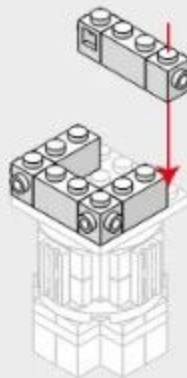

3

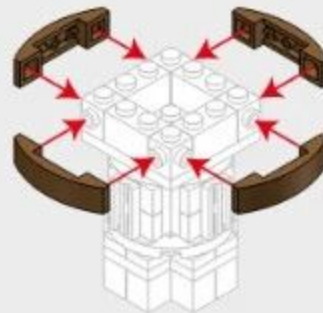

4



5



51

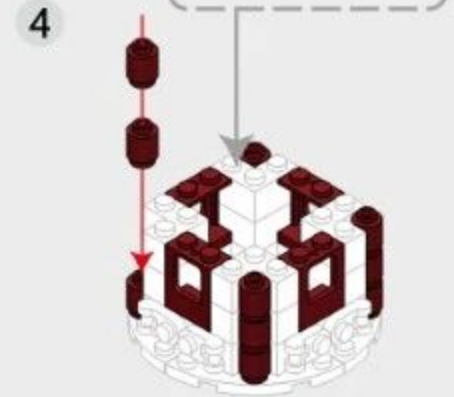
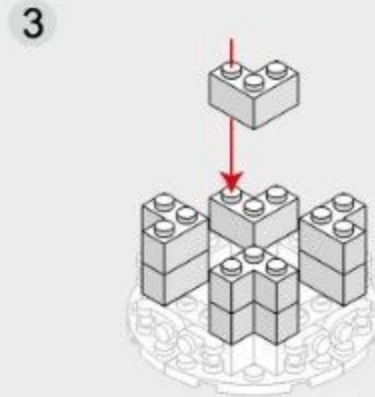
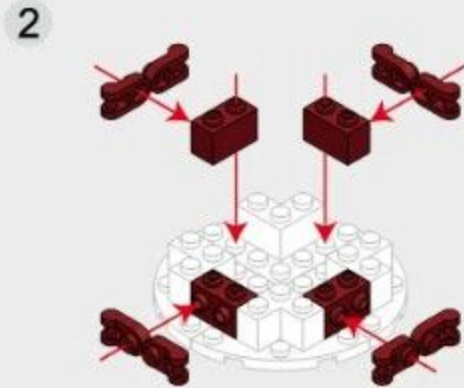
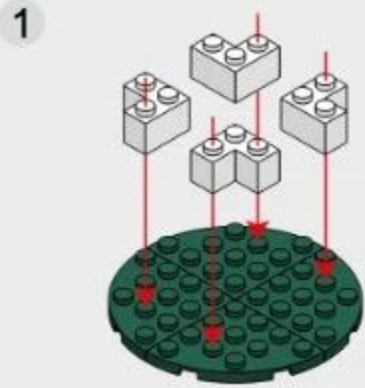

52

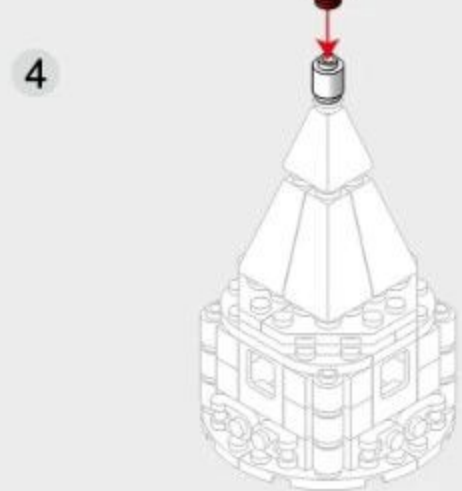
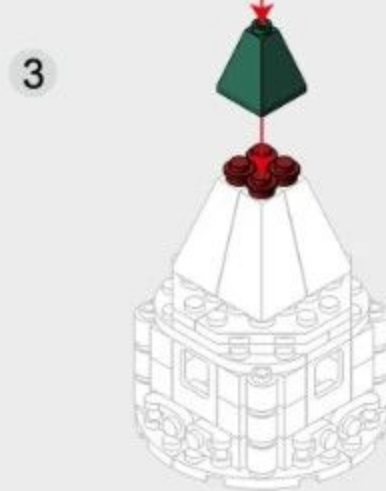
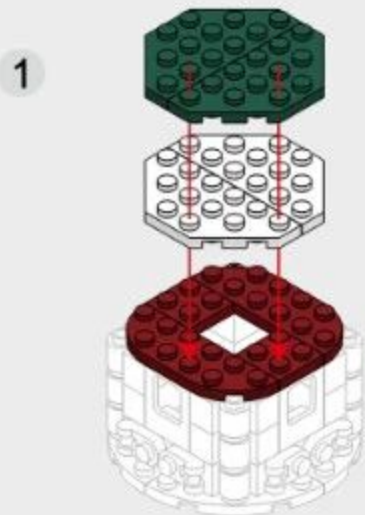
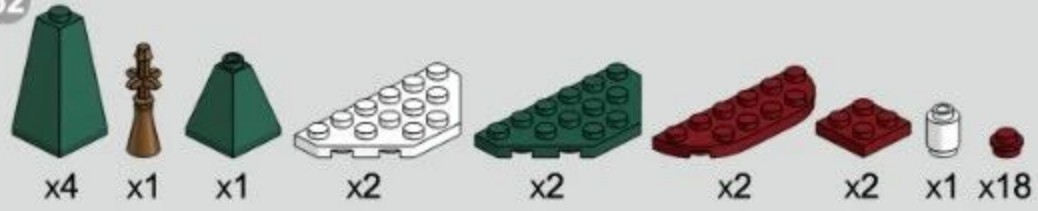

53

26 + 34



54

53 + 38 + 44 + 48

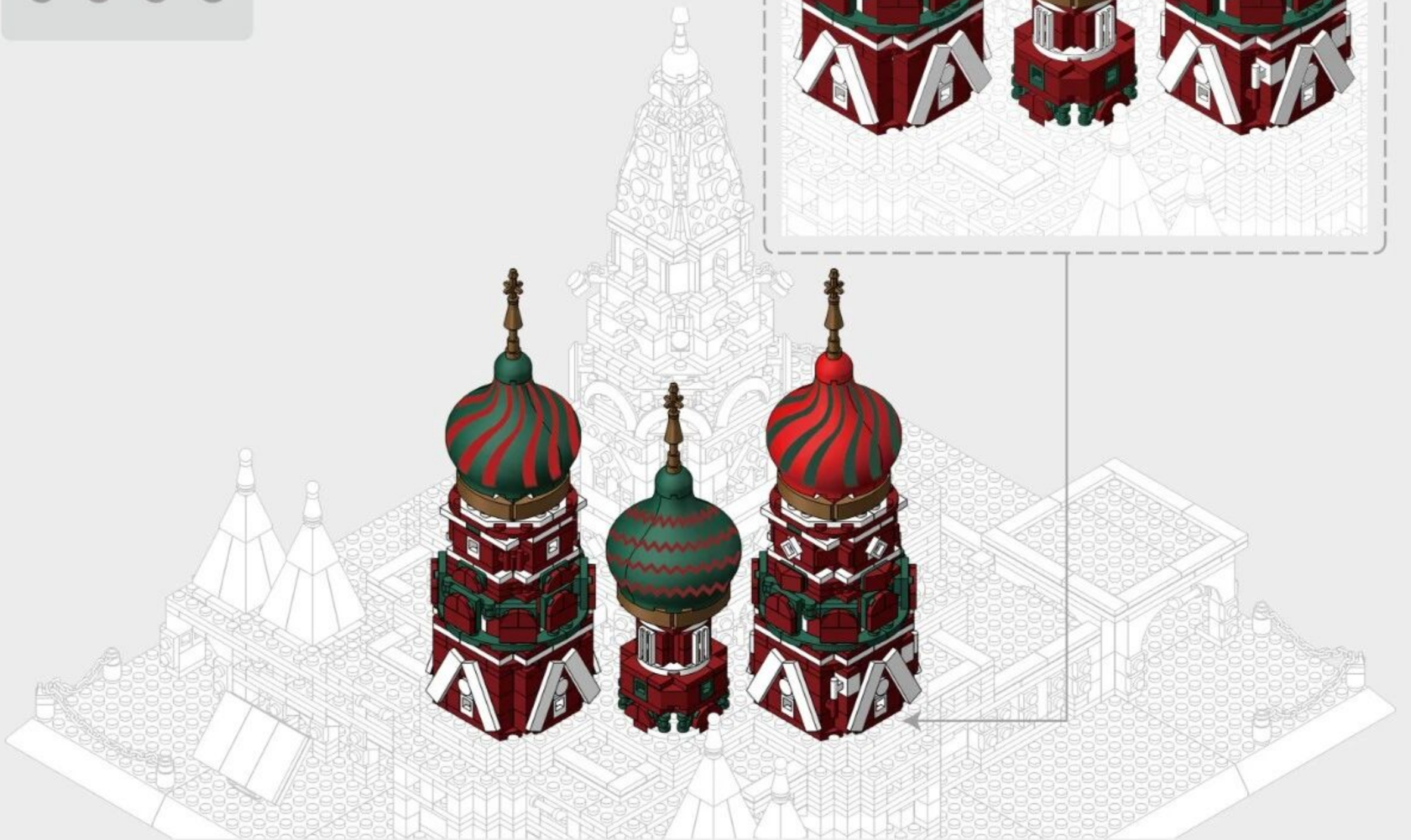

55

54 + 45 + 48

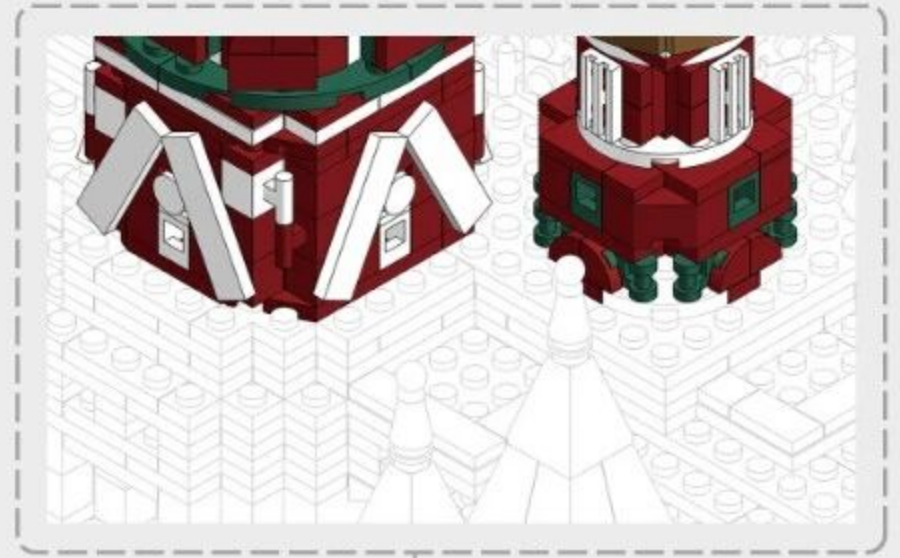
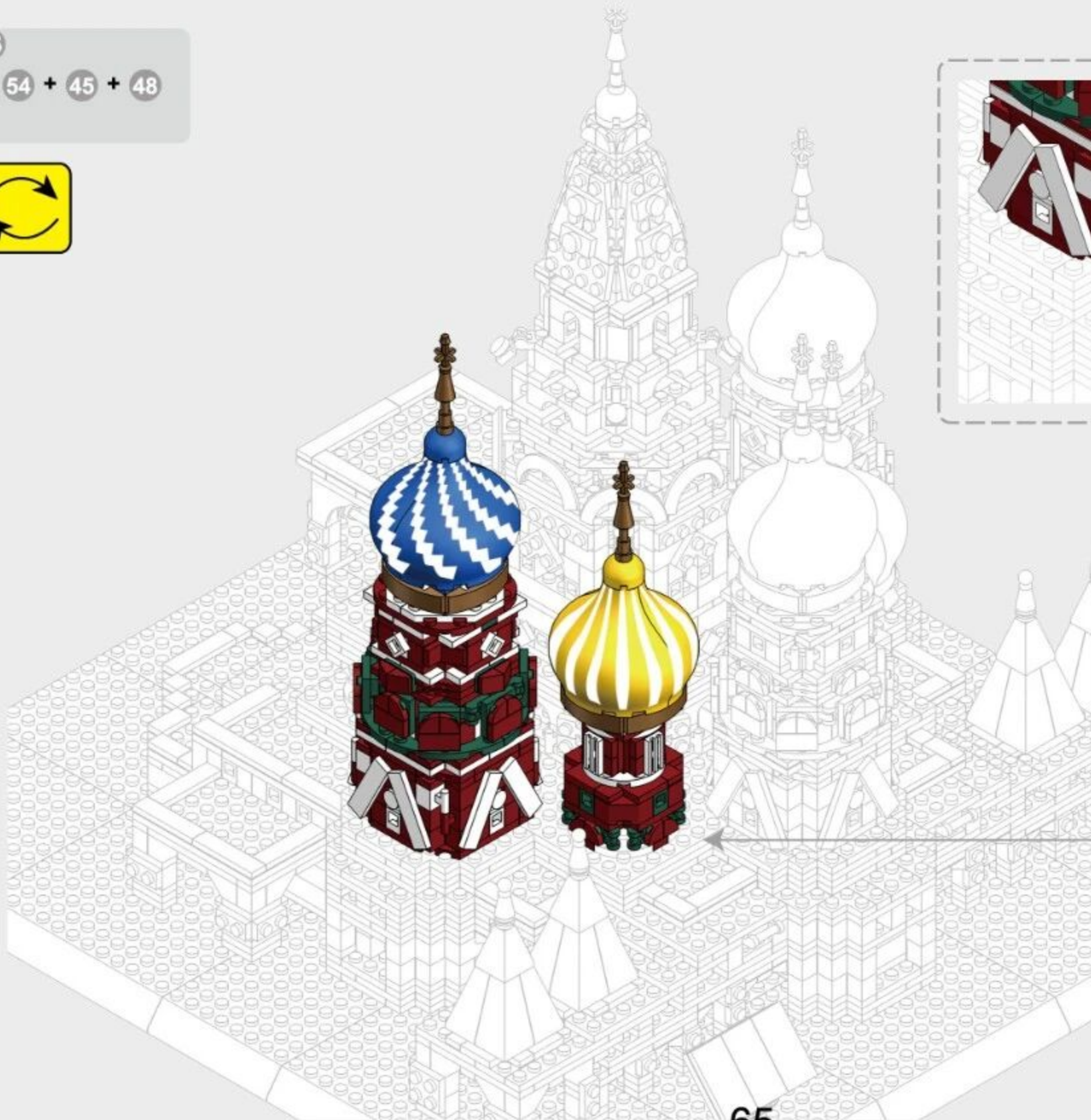

56

55 + 38 + 48 + 52

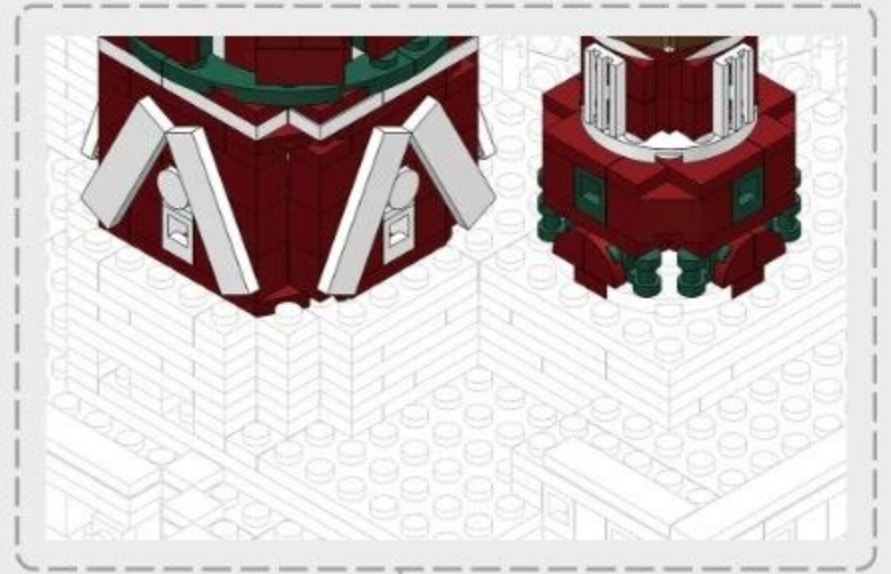
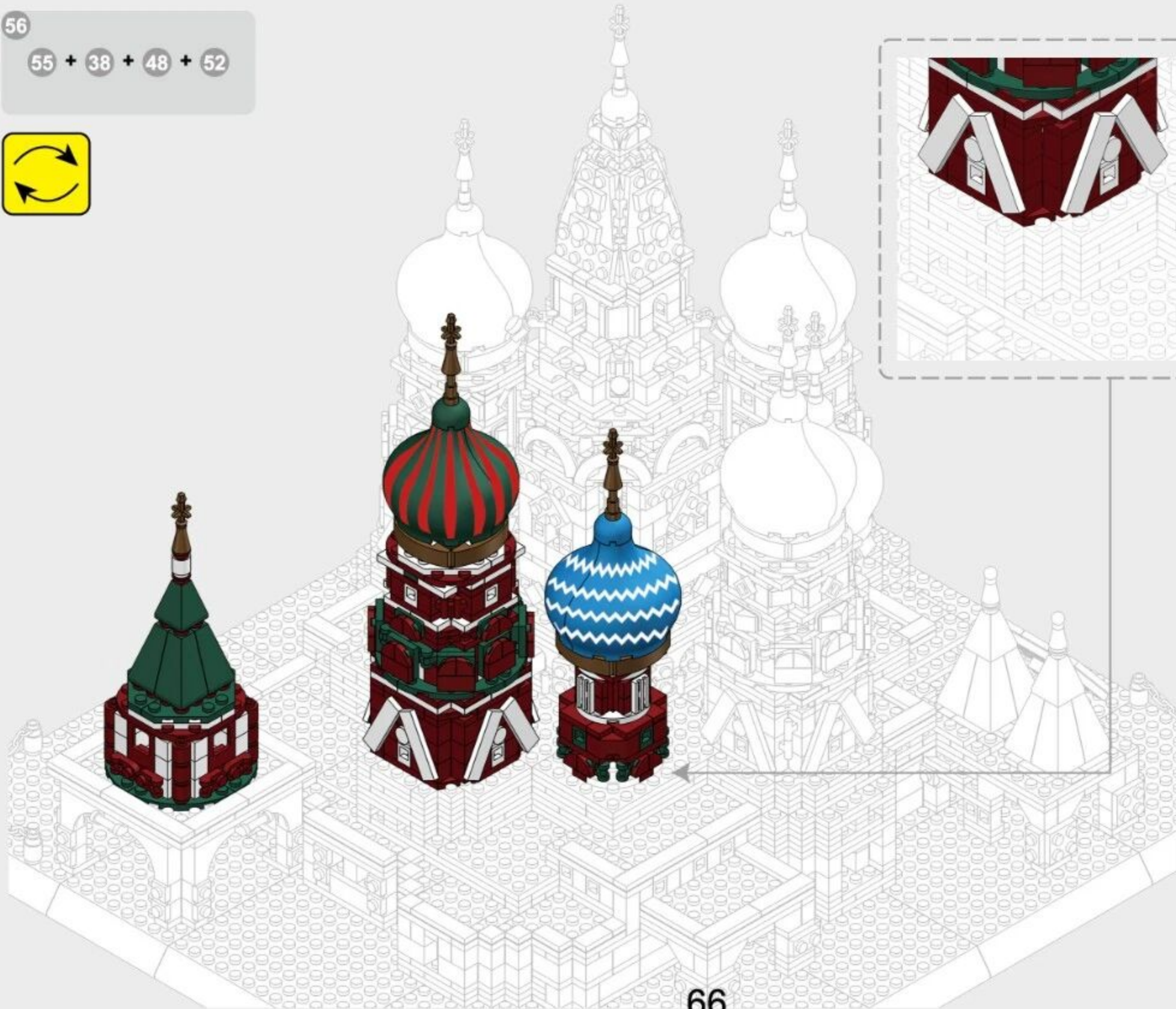

57

56 + 48 + 50

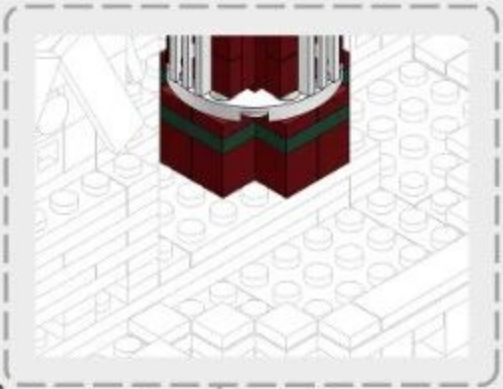
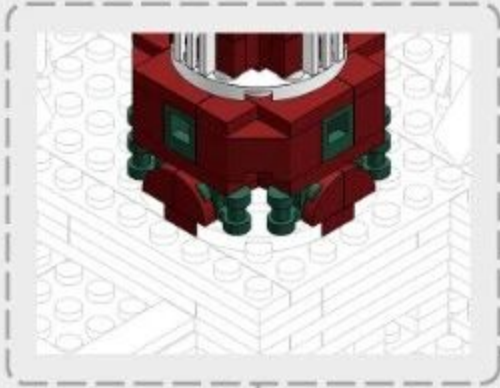

67

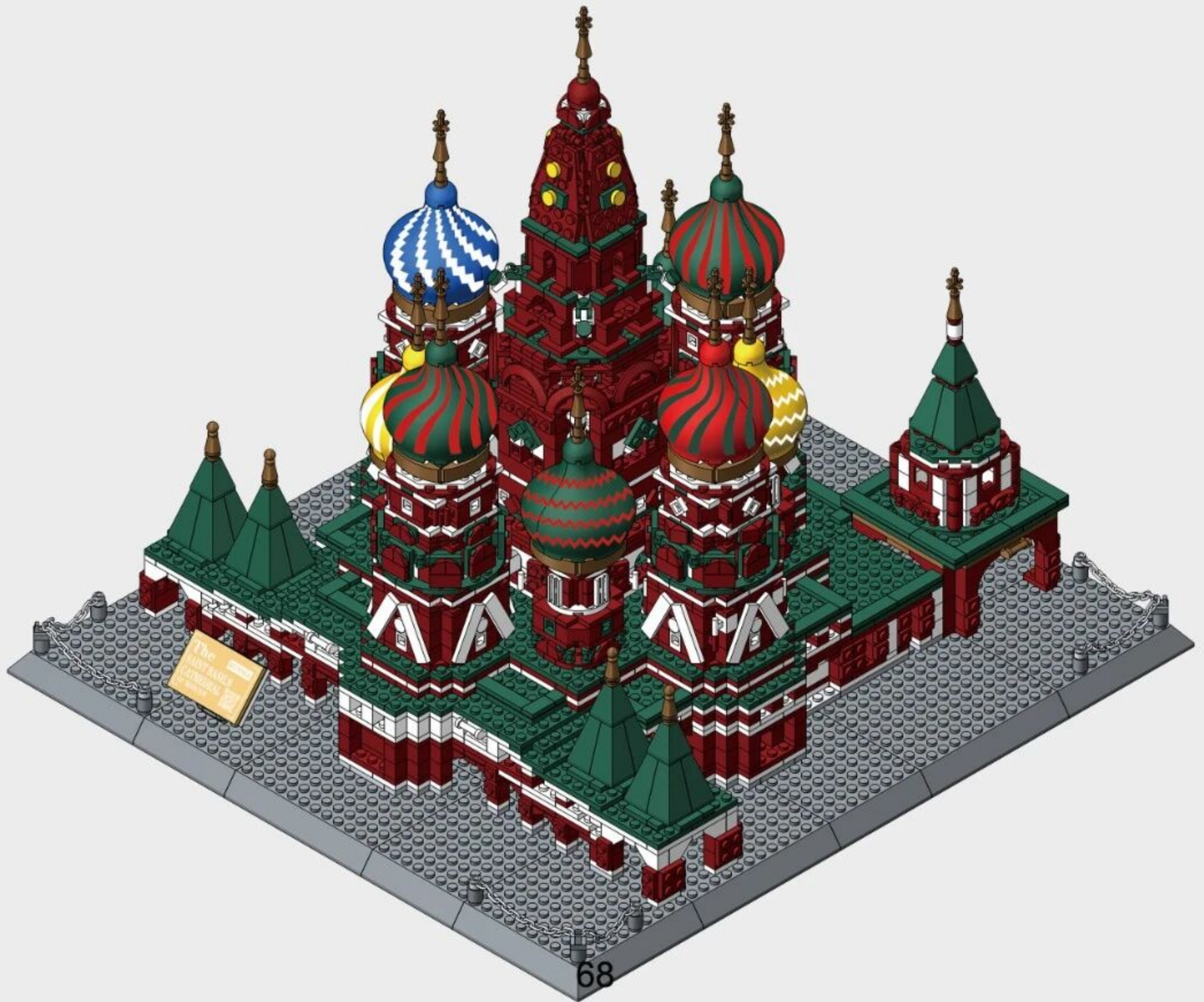

The
MAYNARD
FRANKLIN

ARCHITECTURE

The World's great architecture

- Shaping Skills
- Imagination & Curiosity
- Mathematical
- Self Discovery & Perception
- Parent-Child Interaction
- Problem Solving
- Creativity



✦ **THE NIOMON OF KYOTO**
Item NO.6212 50X40X11.6MM 2409PCS
京都仁王门



✦ **THE COLOSSEUM OF ROME**
Item NO.5225 45X30X9MM 1758PCS
罗马斗兽场



✦ **THE STATUE OF LIBERTY**
Item NO.5227 50X35X8MM 1686PCS
纽约自由女神



✦ **THE YELLOW CRANE TOWER OF WUHAN**
Item NO.6214 50X40X11.6MM 2912PCS
黄鹤楼



✦ **GREAT PYRAMIDS OF GIZA**
Item NO.4210 30X40X7MM 643PCS
埃及吉萨金字塔



✦ **ELIZABETH TOWER**
Item NO.4211 30X40X7MM 910PCS
英国伦敦伊丽莎白塔



✦ **FONTANA DI TREVI**
Item NO.4212 30X40X7MM 688PCS
罗马许愿池



✦ **THE LOUVRE**
Item NO.4213 30X40X7MM 821PCS
法国巴黎卢浮宫



✦ **THE WHITE HOUSE**
Item NO.4214 30X40X7MM 979PCS
美国华盛顿白宫



✦ **THE CN TOWER-CANADA**
Item NO.4215 30X40X7MM 400PCS
加拿大多伦多电视塔



✦ **LINCOLN MEMORIAL**
Item NO.4216 30X40X7MM 979PCS
美国林肯纪念馆



✦ **MARINA BAY SANDS**
Item NO.4217 30X40X7MM 881PCS
新加坡金沙酒店



✦ **MERLION STATUE-SINGAPORE**
Item NO.4218 30X40X7MM 503PCS
新加坡鱼尾狮雕像



✦ **THE TOWER BRIDGE OF LODON**
Item NO.4219 30X40X7MM 969PCS
伦敦塔桥



✦ **FLATIRON BUILDING**
Item NO.4220 30X40X7MM 838PCS
美国熨斗大厦



✦ **NOTRE-DAME DE PARIS**
Item NO.5210 45X30X9MM 1380PCS
法国巴黎圣母院大教堂



✦ **TAJ MAHAL OF AGRA**
Item NO.5211 45X30X9MM 1505PCS
印度阿格拉泰姬陵



✦ **EMPIRE STATE BUILDING**
Item NO.5212 45X30X9MM 1995PCS
美国纽约帝国大厦



✦ **PETRONAS TOWERS**
Item NO.5213 45X30X9MM 1160PCS
马来西亚吉隆坡国油双峰塔



✦ **THE LEANING TOWER**
Item NO.5214 45X30X9MM 1392PCS
意大利比萨斜塔



✦ **THE TOWER BRIDGE**
Item NO.5215 45X30X9MM 1033PCS
英国伦敦双子桥



✦ **THE BIG BEN**
Item NO.5216 45X30X9MM 1642PCS
英国伦敦大笨钟



✦ **THE EIFFEL TOWER**
Item NO.5217 45X30X9MM 978PCS
法国巴黎埃菲尔铁塔



✦ **THE ORIENTAL PEARL TOWER**
Item NO.5224 45X30X9MM 1109PCS
中国上海东方明珠



✦ **THE TIAN AN MEN**
Item NO.5218 45X30X9MM 758PCS
中国北京天安门



✦ **THE SPASSKAYA TOWER**
Item NO.5219 45X30X9MM 1044PCS
俄罗斯克里姆林宫



✦ **THE BURJAL ARAB HOTEL**
Item NO.5220 45X30X9MM 1307PCS
迪拜帆船酒店



✦ **THE TAIPEL 101**
Item NO.5221 45X30X9MM 1511PCS
中国台北101大楼



✦ **THE TEMPLE OF HEAVEN**
Item NO.5222 45X30X9MM 1052PCS
中国北京故宫天坛



✦ **THE GOLDEN GATE BRIDGE**
Item NO.6210 54X42X10MM 1977PCS
美国旧金山金门大桥



✦ **THE BRANDENBURG**
Item NO.6211 54X42X10MM 1552PCS
德国勃兰登堡门



✦ **THE IMPERIAL HOTEL**
Item NO.5226 500X350X80MM 1375PCS
东京帝国饭店



✦ **THE TRIUMPHAL ARCH**
Item NO.5223 45X30X9MM 1401PCS
法国巴黎凯旋门

THE SAINT BASIL'S CATHEDRAL OF MOSCOW



Russia
The world's great architecture

COUNTRY: Russia
CITY: Moscow

INTRODUCTION

The Cathedral of Vasily the Blessed (Russian: собор Василия Блаженного, Sobor Vasiliya Blazhennogo, commonly known as Saint Basil's Cathedral, is a church in Red Square in Moscow, Russia and is regarded as a symbol of the country. The building, now a museum, is officially known as the Cathedral of the Intercession of the Most Holy Theotokos on the Moat (Собор Покрова Пресвятой Богородицы, что на Рву, Sobor Pokrova Præsvyatoy Bogoroditsy, što na Rvu) or Pokrovsky Cathedral (Покровский собор). It was built from 1555 to 1561 on orders from Ivan the Terrible and commemorates the capture of Kazan and Astrakhan. It was the city's tallest building until the completion of the Ivan the Great Bell Tower in 1600.

The original building, known as Trinity Church and later Trinity Cathedral, contained eight churches arranged around a ninth, central church of Intercession; a tenth church was erected in 1588 over the grave of venerated local saint Vasily (Basil). In the 16th and 17th centuries, the church, perceived (as with all churches in Byzantine Christianity) as the earthly symbol of the Heavenly City, was popularly known as the "Jerusalem" and served as an allegory of the Jerusalem Temple in the annual Palm Sunday parade attended by the Patriarch of Moscow and the Tsar.

The building is shaped like the flame of a bonfire rising into the sky, a design that has no parallel in Russian architecture. Dmitry Shvidkovsky, in his book *Russian Architecture and the West*, states that "It is like no other Russian building. Nothing similar can be found in the entire millennium of Byzantine tradition from the fifth to the fifteenth century ... a strangeness that astonishes by its unexpectedness, complexity and dazzling interleaving of the manifold details of its design." The cathedral foreshadowed the climax of Russian national architecture in the 17th century.

As part of the program of state atheism, the church was confiscated from the Russian Orthodox community as part of the Soviet Union's anti-faith campaigns and has operated as a division of the State Historical Museum since 1928. It was completely secularized in 1929 and remains a federal property of the Russian Federation. The church has been part of the Moscow Kremlin and Red Square UNESCO World Heritage Site since 1990. It is not actually within the Kremlin, but often served as a visual metonym for Russia and the USSR in western media throughout the Cold War and to the modern day, to the point of being confused at times with the Kremlin itself by foreigners. Since 1997 weekly Orthodox Christian services with prayer to St. Basil have been restored.

Собор Покрова Пресвятой Богородицы, что на Рву — православный храм на Красной площади в Москве, памятник русской архитектуры. Строительство собора велось с 1555 по 1561 год. Собор объединяет одиннадцать церквей, часть из которых посвящена в честь святой, для памяти которой призывали на решающие бои за Казань. Центральная церковь освящена в честь Покрова Богородицы, вокруг которой группируются отдельные церкви в честь Святой Троицы, Входа Господня в Иерусалим, Николы Великого, Трёх Патриархов, Александра, Иоанна и Павла Нового, Григория Армянского, Ксении и др.

