

# SYDNEY OPERA HOUSE

ÓPERA DE SÍDNEY

Sydney, Australia

The world's great architecture



6+ / 8210 / 2937PCS  
Suitable Age    Product Number    Parts Total



# Architecture

It will be a city...

这将构成一座城市...

# ABOUT THE PRODUCT

关于产品

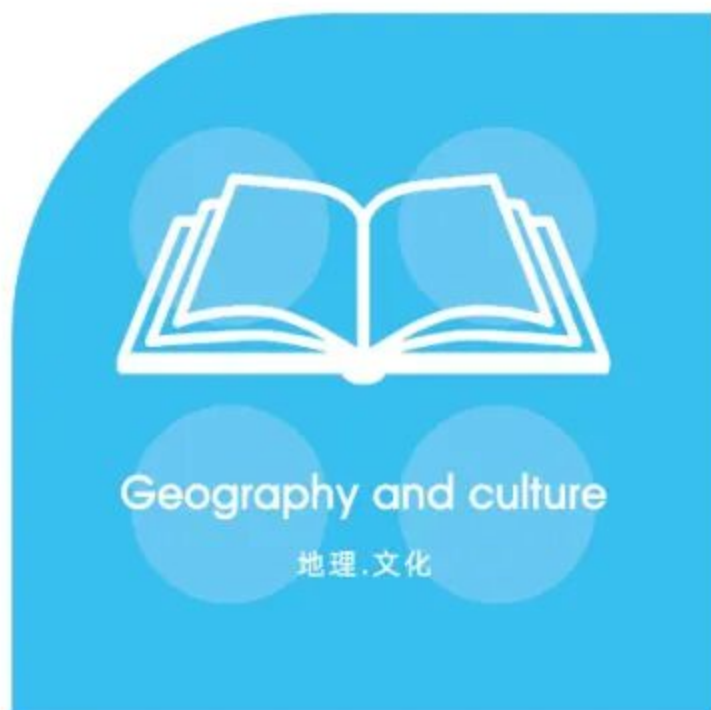

## ARCHITECTURE

WANGE The world's great architect since 1991

# Sydney Opera House



Convenient Bennelong Point  
(Bennelong Point) in Sydney Har-  
bour, north of Sydney City, New  
South Wales, Australia



# Sydney Opera House

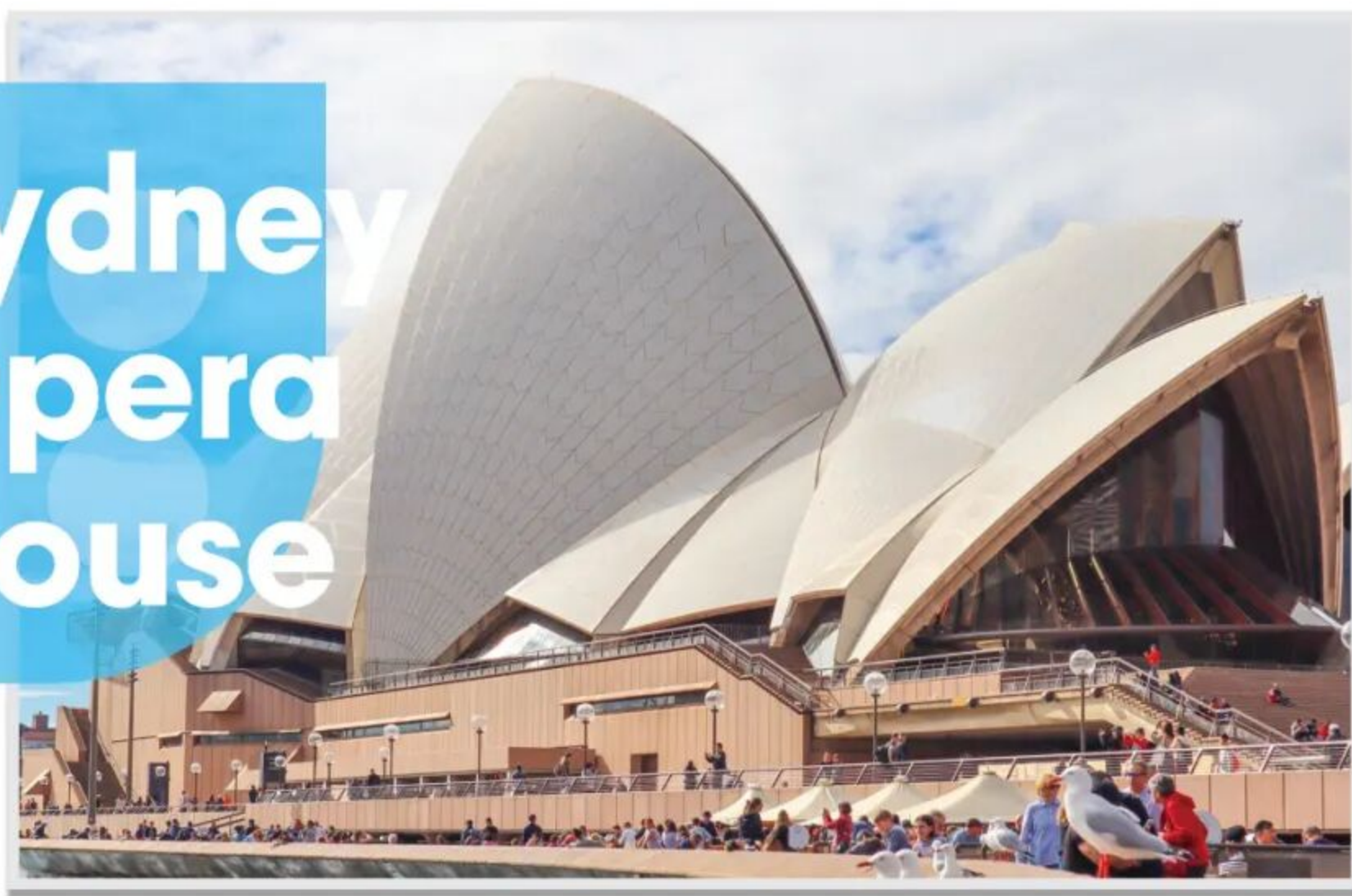

## Geography and culture

地理·文化



The Sydney Opera House is a multi-venue performing arts centre in Sydney. Located on the banks of the Sydney Harbour, it is often regarded as one of the world's most famous and distinctive buildings and a masterpiece of 20th century architecture.





Ópera de Sídney

**Sydney Opera** ■

**House**

Australia

The contents of this chapter refer to the Wikipedia website.

本章内容参考维基百科网站，更多资讯可自行查阅。

The world's great architecture

# Buildings and layout

■ 建筑物和布局



The Sydney Opera House is a multi-venue performing arts centre in Sydney. Located on the banks of the Sydney Harbour, it is often regarded as one of the world's most famous and distinctive buildings and a masterpiece of 20th century architecture. Designed by Danish architect Jørn Utzon, but completed by an Australian architectural team headed by Peter Hall, the building was formally opened on 20 October 1973[5] after a gestation beginning with Utzon's 1957 selection as winner of an international design competition. The Government of New South Wales, led by the premier, Joseph Cahill, authorised work to begin in 1958 with Utzon directing construction. The government's decision to build Utzon's design is often overshadowed by circumstances that followed, including cost and scheduling overruns as well as the architect's ultimate resignation.

La Ópera de Sídney, situada en la ciudad de Sídney, estado de Nueva Gales del Sur, Australia, es uno de los edificios más famosos y distintivos del siglo xx. Declarado en 2007 Patrimonio de la Humanidad, fue diseñado por el arquitecto danés Jørn Utzon en 1957 e inaugurado el 20 de octubre de 1973. En el edificio se realizan obras de teatro, ballet, ópera o producciones musicales. Es sede de la compañía de Ópera de Australia, la Compañía de Teatro de Sídney y la Orquesta Sinfónica de Sídney. Está administrada por la Opera House Trust, un organismo público del gobierno estatal de Nueva Gales del Sur.



## Description

The facility features a modern expressionist design, with a series of large precast concrete "shells", each composed of sections of a sphere of 75.2 metres radius, forming the roofs of the structure, set on a monumental podium. The building covers 1.8 hectares of land and is 183 m long and 120 m wide at its widest point. It is supported on 588 concrete piers sunk as much as 25 m below sea level. The highest roof point is 67 metres above sea-level which is the same height as that of a 22-storey building. The roof is made of 2,194 pre-cast concrete sections, which weigh up to 15 tonnes each.

La Casa de la Ópera de Sídney es una construcción expresionista y con un diseño radicalmente innovador, conformado por una serie de grandes conchas prefabricadas, cada una tomada de la misma semiesfera, que forman los tejados de la estructura. El Teatro de la Ópera cubre 1,8 hectárea. Tiene 185 metros de largo y alrededor de 120 metros de anchura máxima. Se apoya en 580 pilares hundidos hasta una profundidad de 25 metros bajo el nivel del mar. Su fuente de alimentación tiene una capacidad equivalente al consumo eléctrico de una ciudad de 25 000 personas. La energía es distribuida por 645 kilómetros de cable.



## History

Planning began in the late 1940s when Eugene Goossens, the Director of the New South Wales State Conservatorium of Music, lobbied for a suitable venue for large theatrical productions. The normal venue for such productions, the Sydney Town Hall, was not considered large enough. By 1954, Goossens succeeded in gaining the support of New South Wales Premier Joseph Cahill, who called for designs for a dedicated opera house. It was also Goossens who insisted that Bennelong Point be the site: Cahill had wanted it to be on or near Wynyard Railway Station in the northwest of the central business district. An international design competition was launched by Cahill on 13 September 1955 and received 233 entries, representing architects from 32 countries. The criteria specified a large hall seating 3,000 and a small hall for 1,200 people, each to be designed for different uses, including full-scale operas, orchestral and choral concerts, mass meetings, lectures, ballet performances, and other presentations.

La idea de construir un teatro de ópera en Sídney comenzó a concretarse en los últimos años de la década de los 40 cuando Eugene Goossens, director del Conservatorio de Música de Sídney del estado de Nueva Gales del Sur sostuvo que la ciudad necesitaba contar con un lugar conveniente para las grandes producciones de teatro. En esa época las producciones teatrales se efectuaban en el edificio del Ayuntamiento de Sídney, un espacio considerado insuficiente para este tipo de producciones. En 1954, Goossens tuvo un gran éxito al obtener el apoyo del primer ministro del estado, Joseph Cahill, quien solicitó diseños para la construcción de un nuevo edificio dedicado expresamente para albergar el teatro de la ópera.

# Design Points

结构难点

Angle calculation

角度的计算

$$a^2 + b^2 = c^2$$

$$S = 4\pi \cdot r^2$$

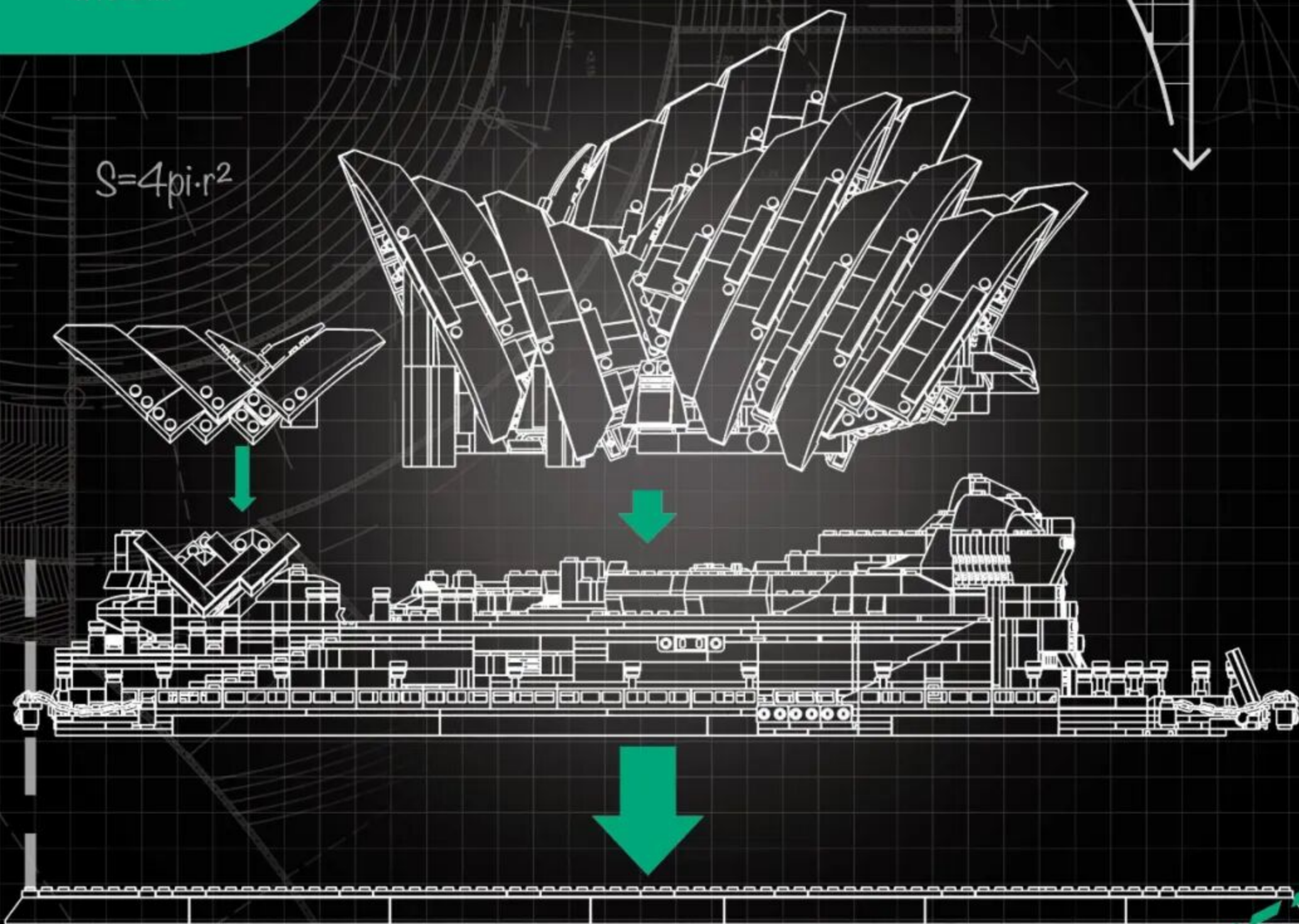

$$\sin^2 a + \cos^2 a = 1$$



Creation and thinking

创作·思考

08

# Special parts

特殊零件的开发利用

$$S=4\pi \cdot r^2$$



**WG1436**  
反斜2X4孔



**WG1242**  
弧栏杆



**WG1437**  
反斜箭2X3孔



**WG1377**  
矮3X4孔



features and functions

特点.功能

# Main Color Matching

配色方案



Pantone Black 6C

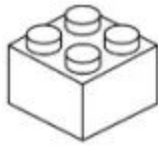

White



Pantone 655C



Pantone 431C



Pantone 123C



Pantone 7427C



Pantone 2310C



Pantone 7509C



Pantone 3435C



Pantone 285C



Pantone Cool Gray 6C



Pantone 7500C



## Color matching

Adopting 3 main colors, white, black and desert yellow as the main color, the more reasonable and blue color matching on the original building, making the product more atmospheric and the whole design is more reasonable.

# Sydney Opera House

悉尼歌剧院



Front

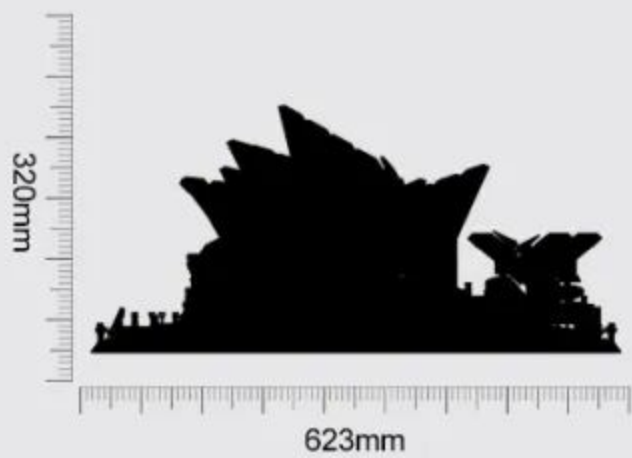

Left

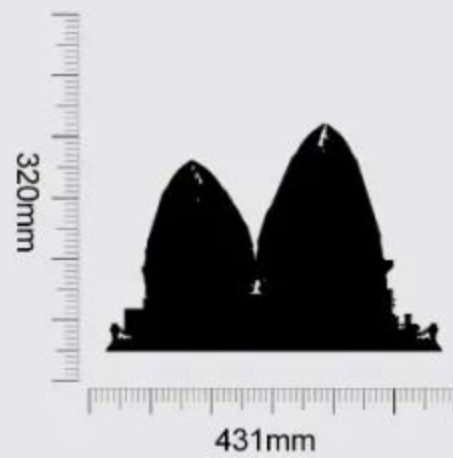

Back

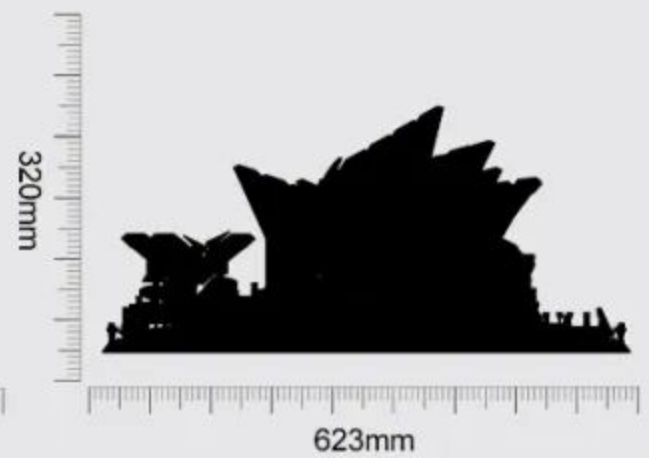

Product Size:623X431X320mm





■ First open the product packaging according to the instructions.

按指导用正确方式拆解产品外包装。



■ Summarize all parts to count the number of familiar accessories.

对照说明书清单确认积木包数量与积木数量。



■ Arranging all accessories by color helps to quickly install the product.

把确认好的积木以类型、颜色进行分类排好以便安装。



■ Carefully install the product and learn about building.

按说明书步骤拼装并完成你的积木模型。



# Instructions For Use

积木起件器使用说明  
Brickseparator

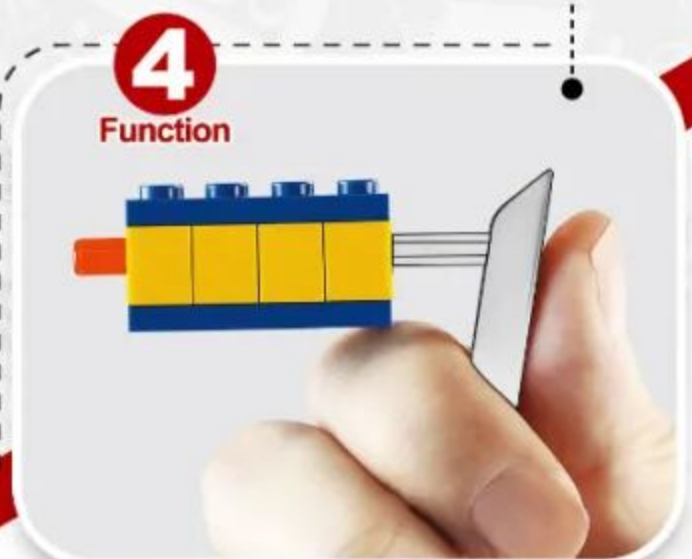
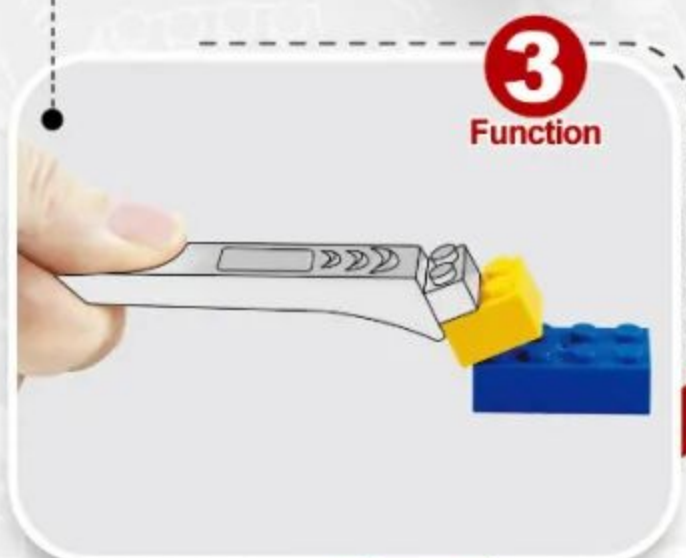
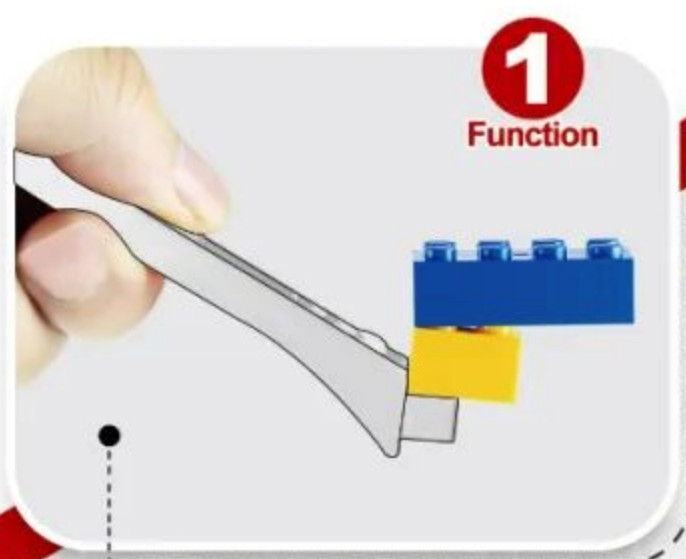

4 ways to make installation easier  
让安装更简单

# 1:1 Physical Reference Table

十字棒配件1:1尺寸参照表



Instructions For Use

让安装更简单

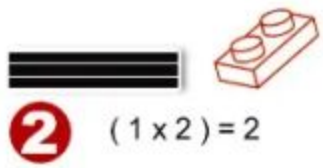

**2**  $(1 \times 2) = 2$

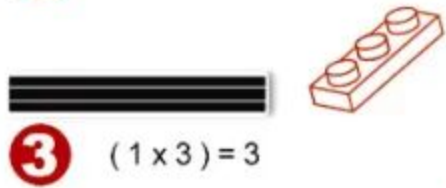

**3**  $(1 \times 3) = 3$

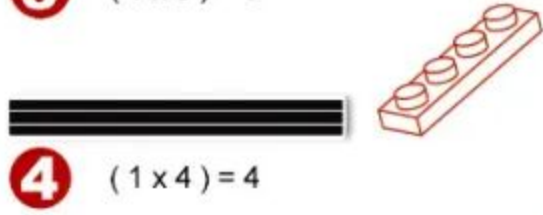

**4**  $(1 \times 4) = 4$



**5**  $(1 \times 5) = 5$



**6**  $(1 \times 6) = 6$



**7**  $(1 \times 7) = 7$



**8**  $(1 \times 8) = 8$



**9**  $(1 \times 9) = 9$



**10**  $(1 \times 10) = 10$



**12**  $(1 \times 12) = 12$



**16**  $(1 \times 16) = 16$



# PARTS LIST

配件清单

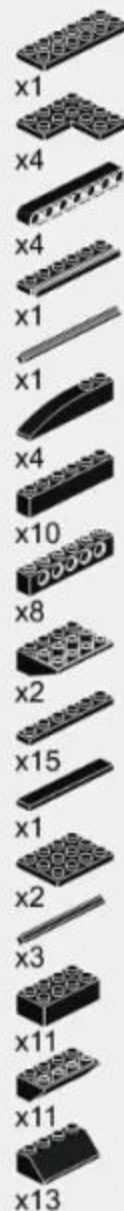
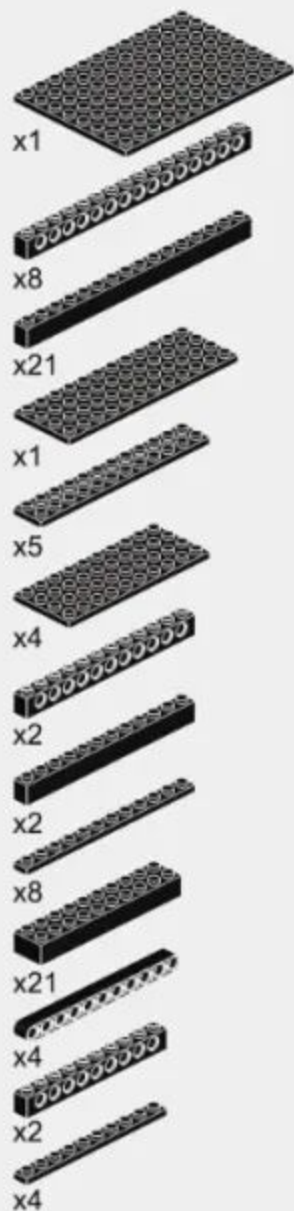

112.5°



135°



产品有增补件请以实物为准

If product has additional parts, please in kind prevail.

# PARTS LIST

配件清单

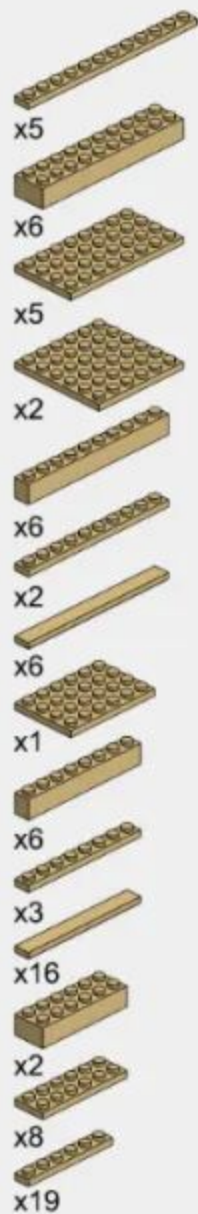
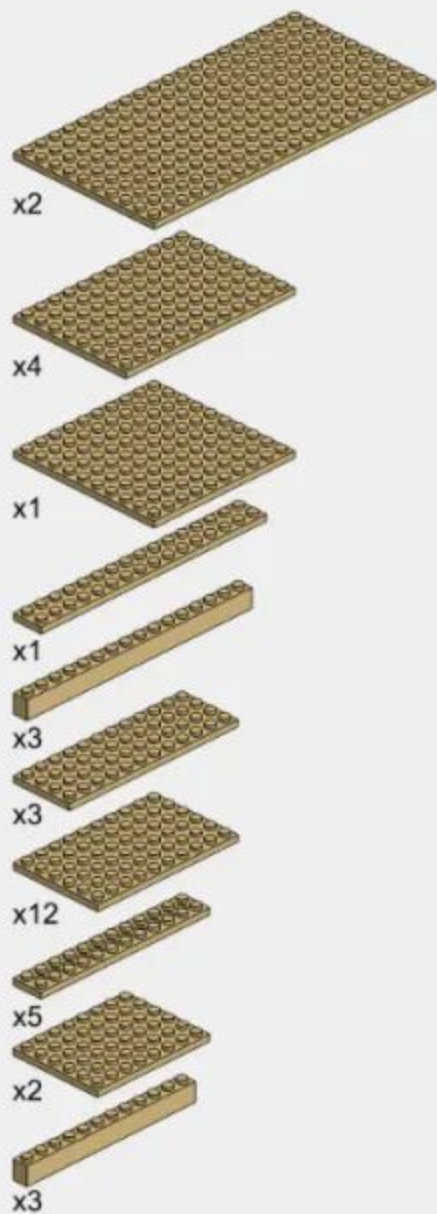

产品有增补件请以实物为准

If product has additional parts, please in kind prevail.







281 PCS

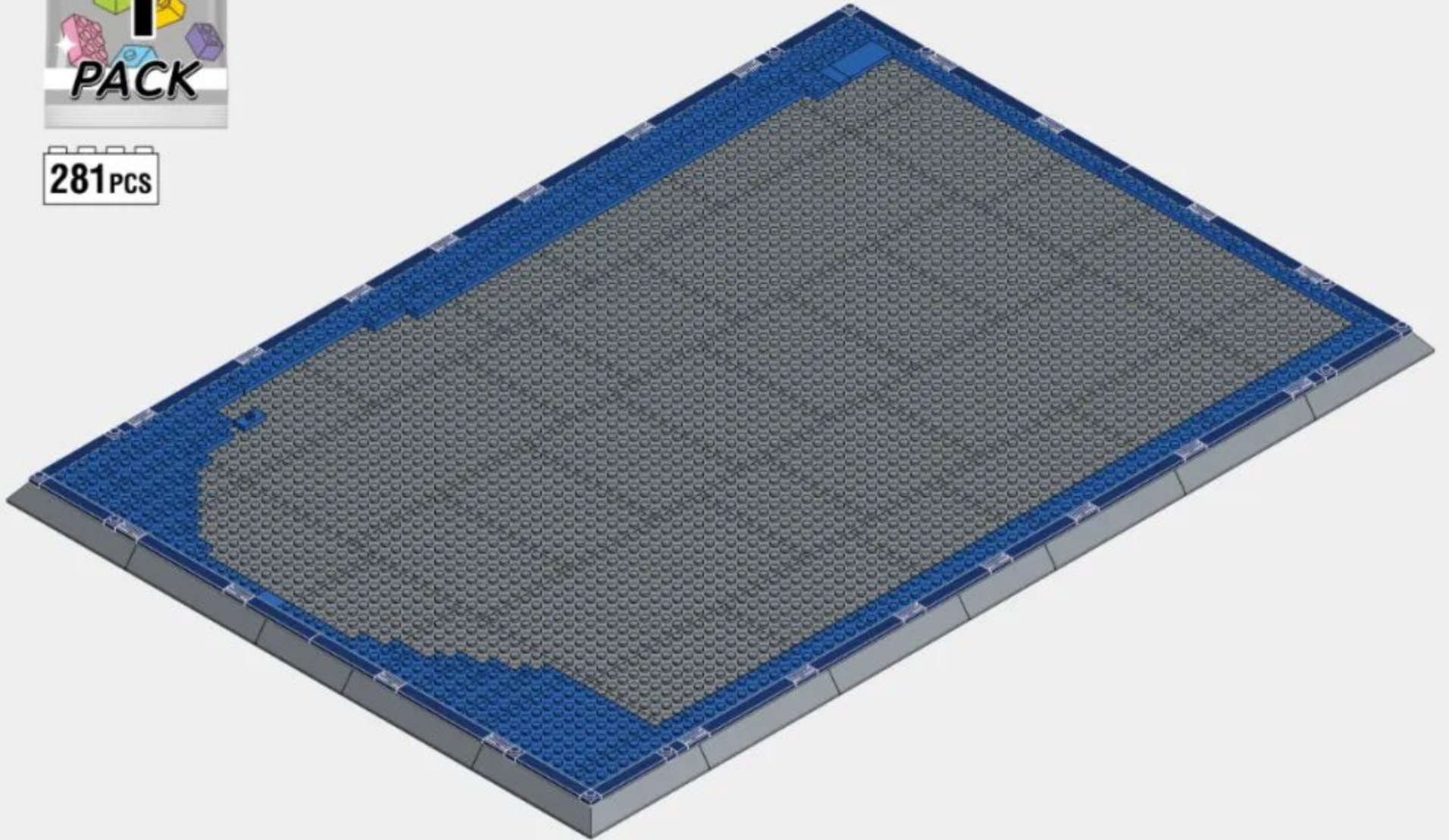

1-1

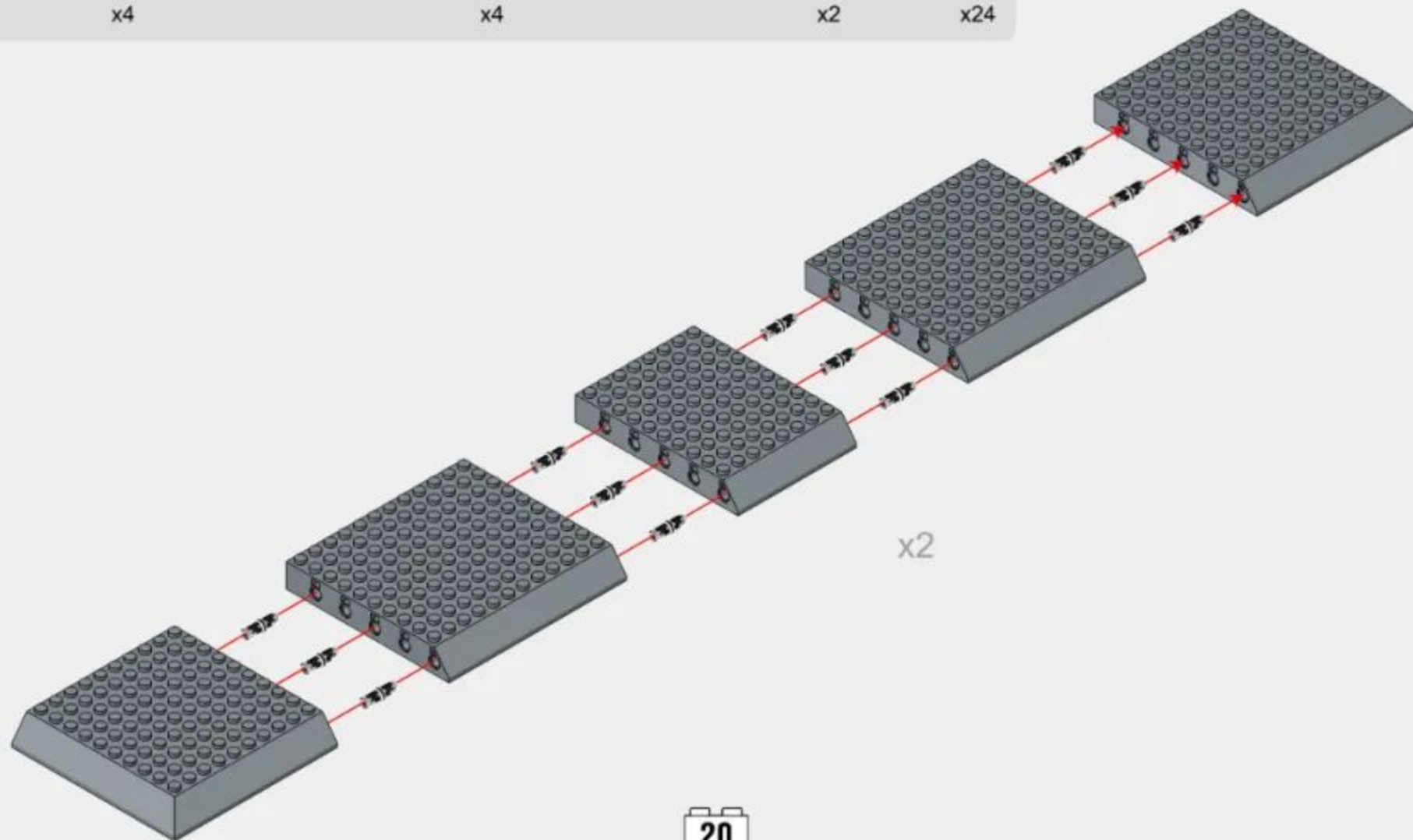
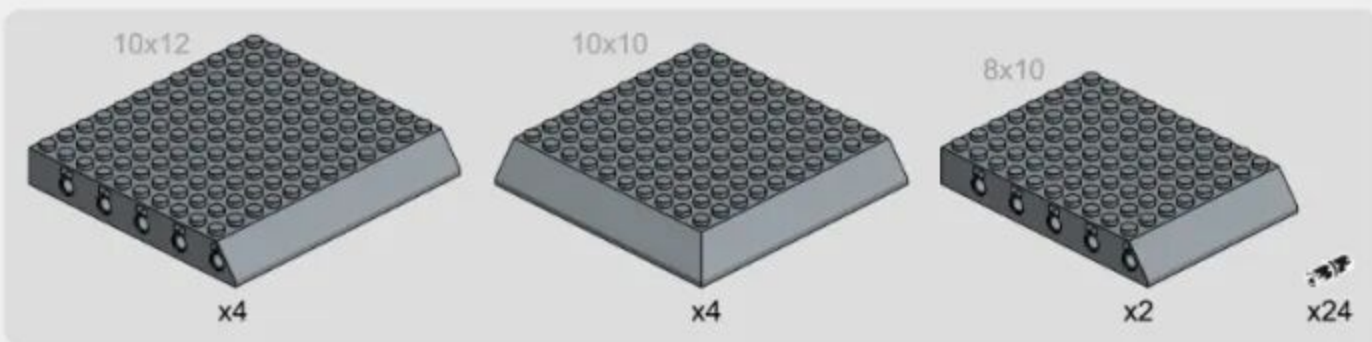

1-2

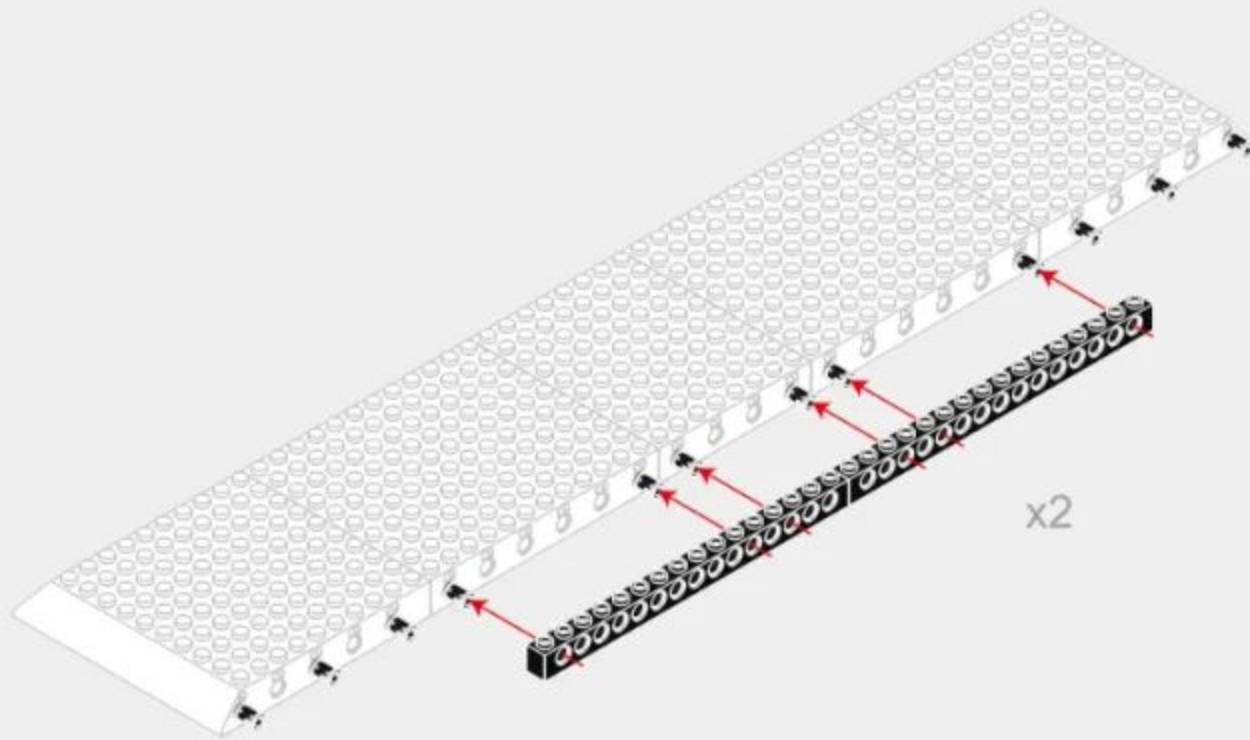
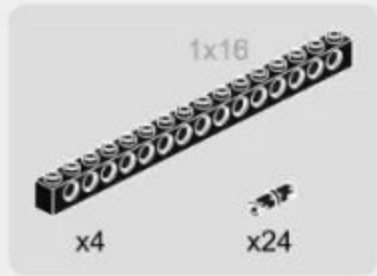

1-3

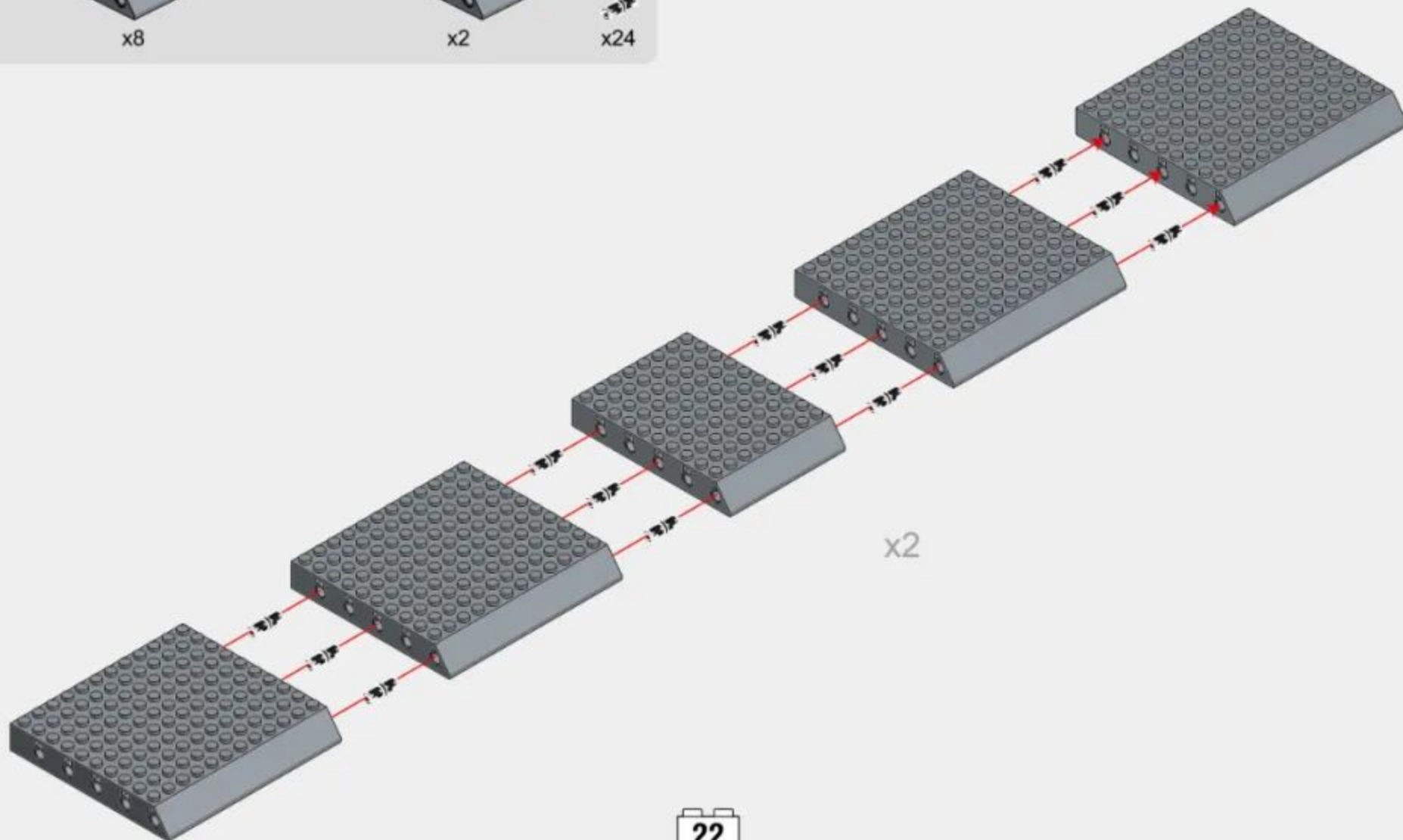
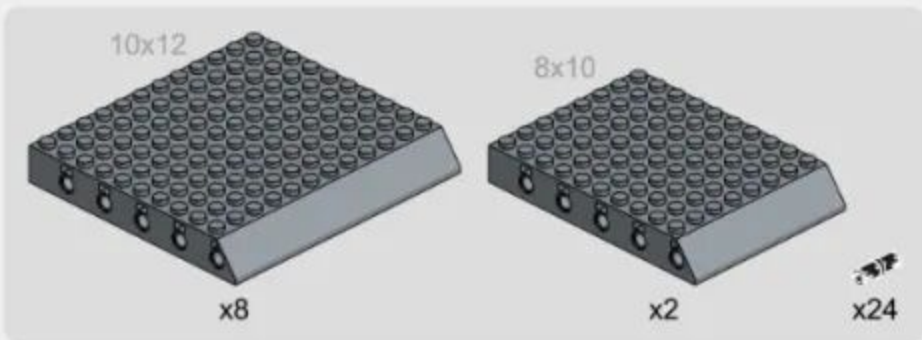

1-4

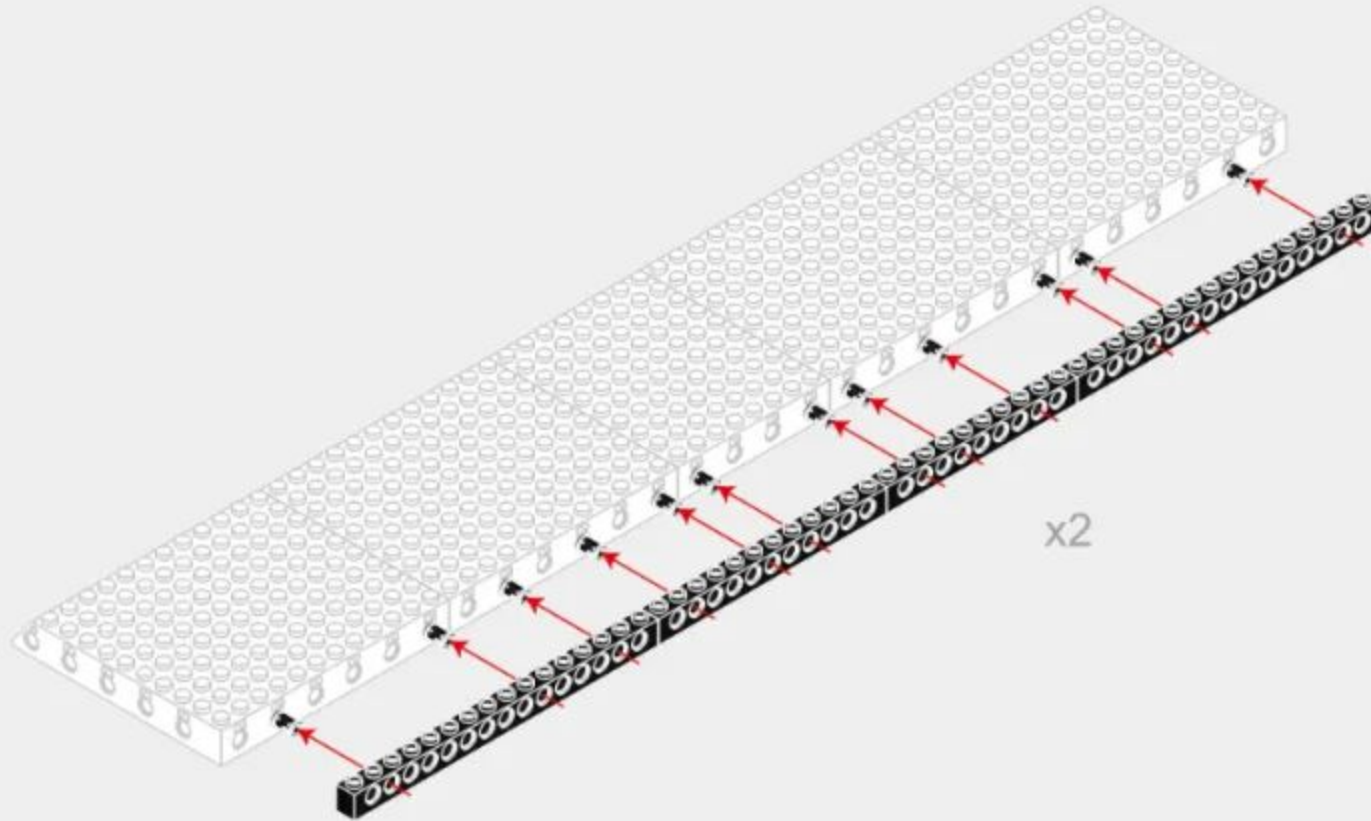
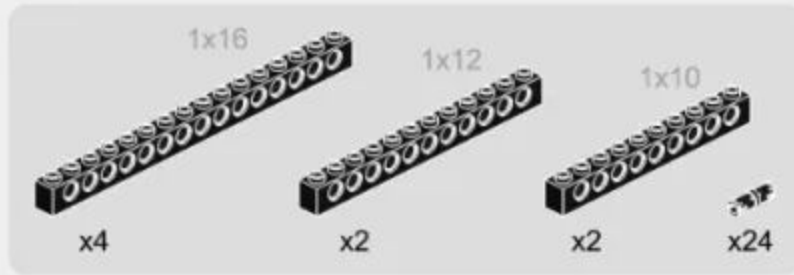

1-5

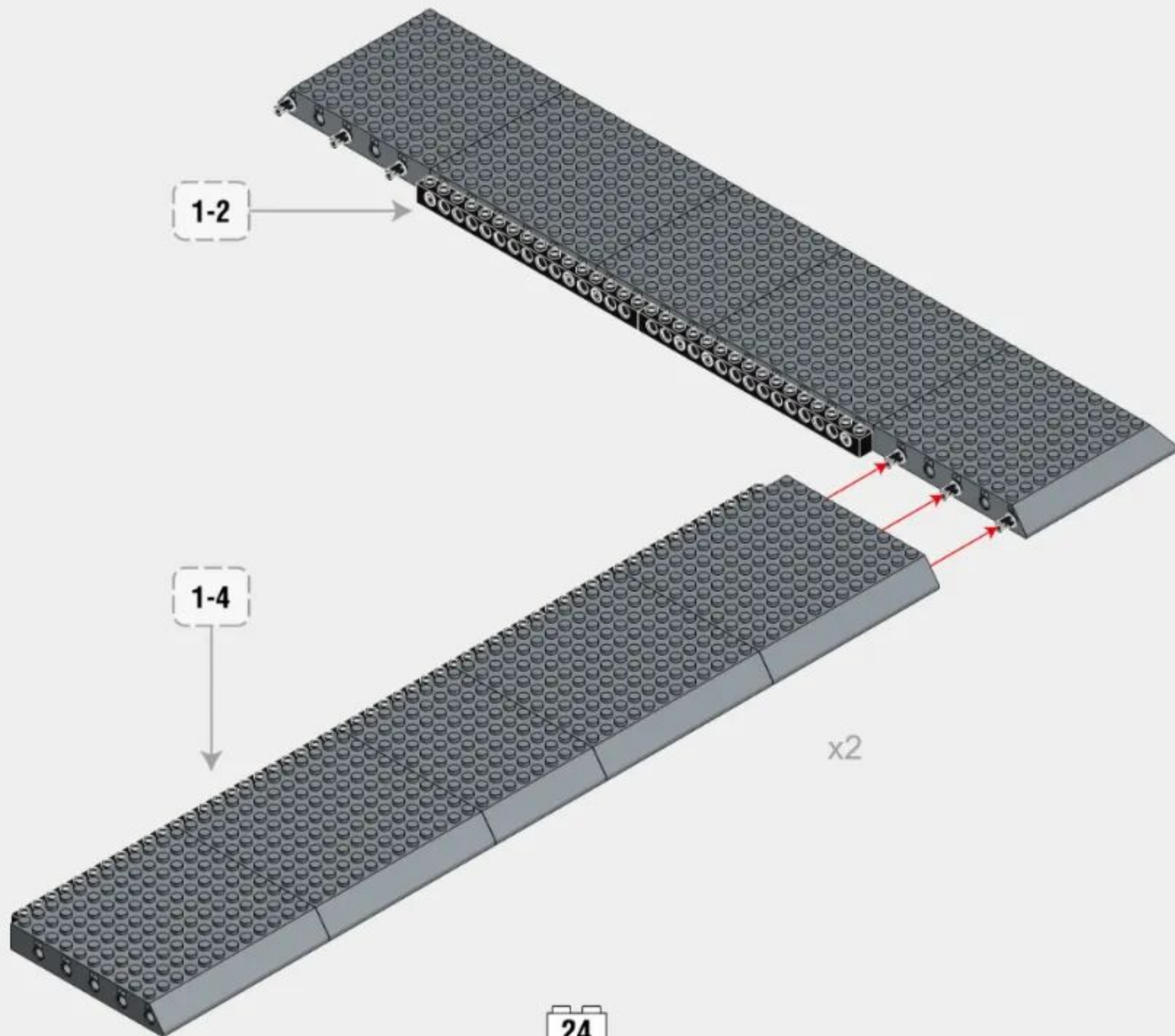

1-6

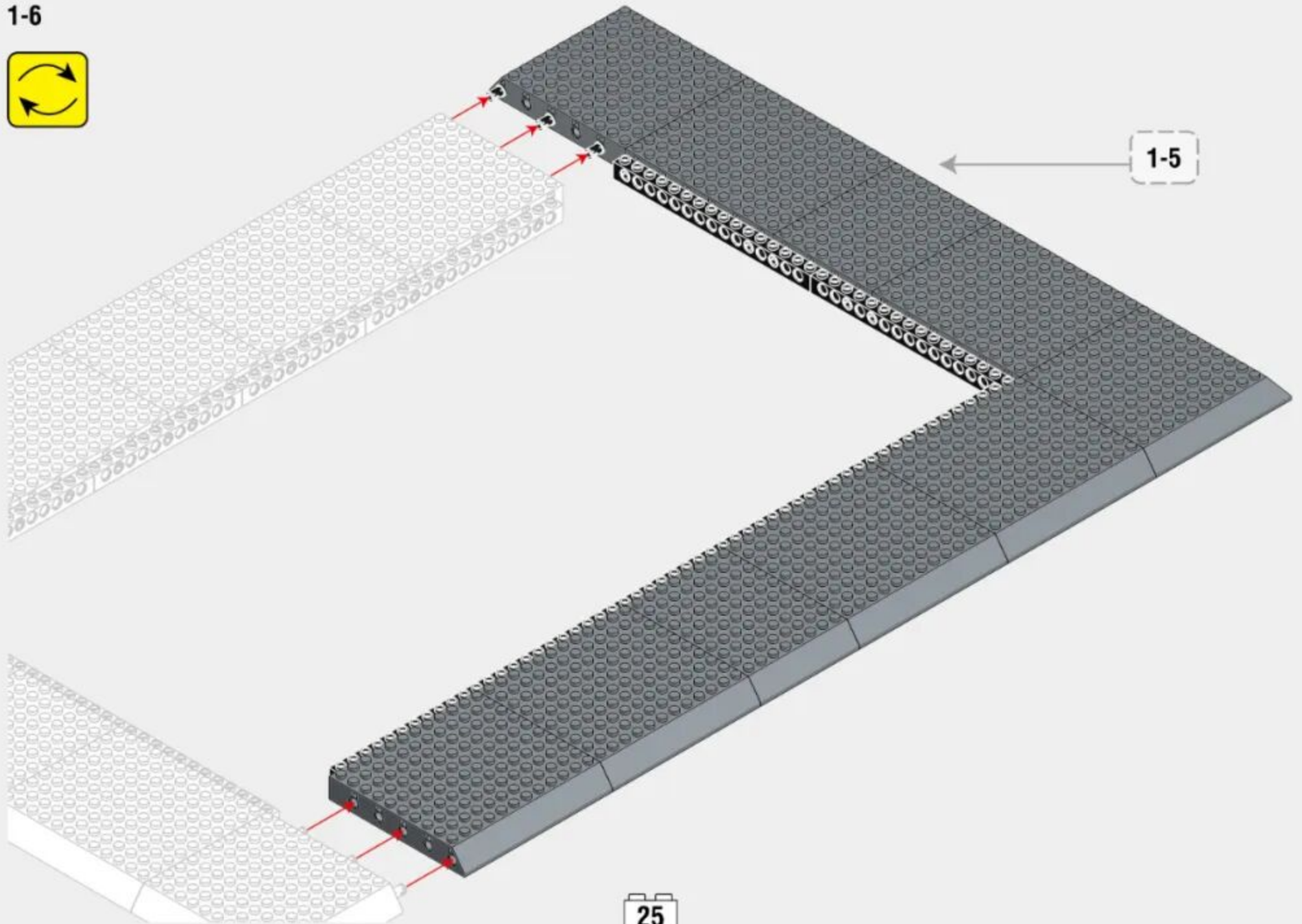

1-7

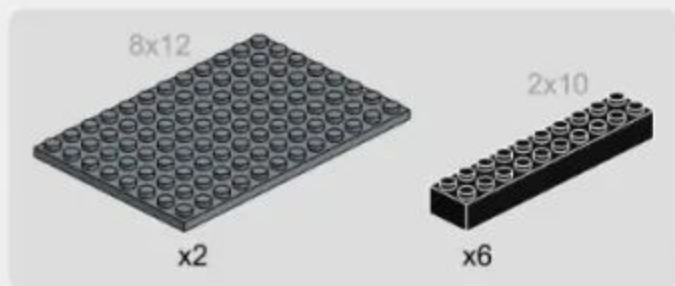

1-8

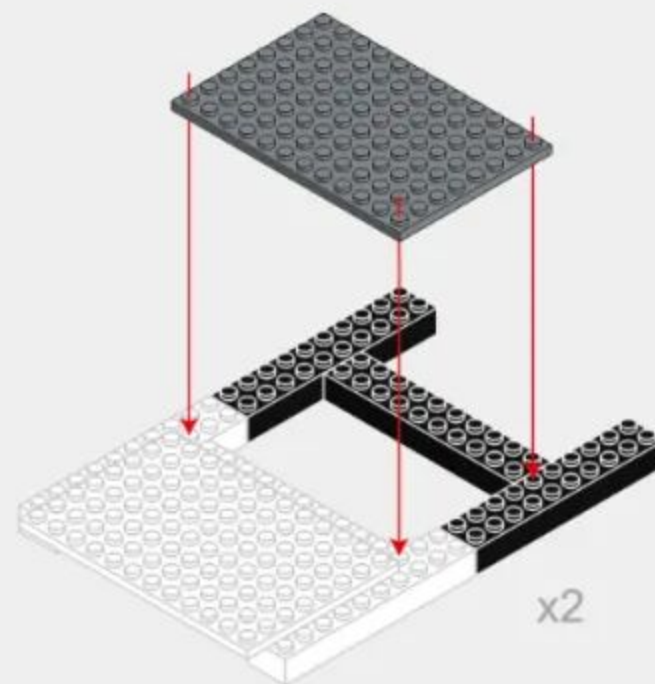
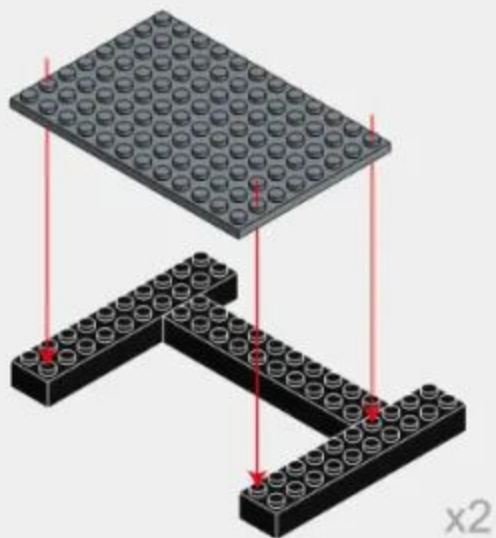
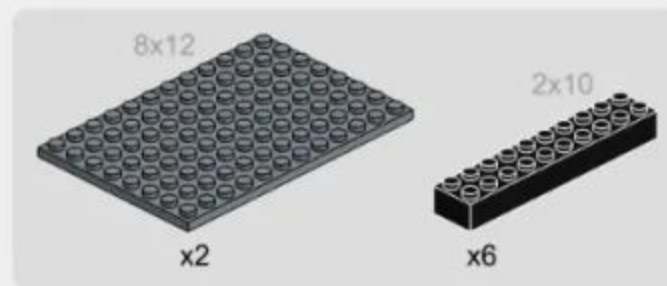

1-9

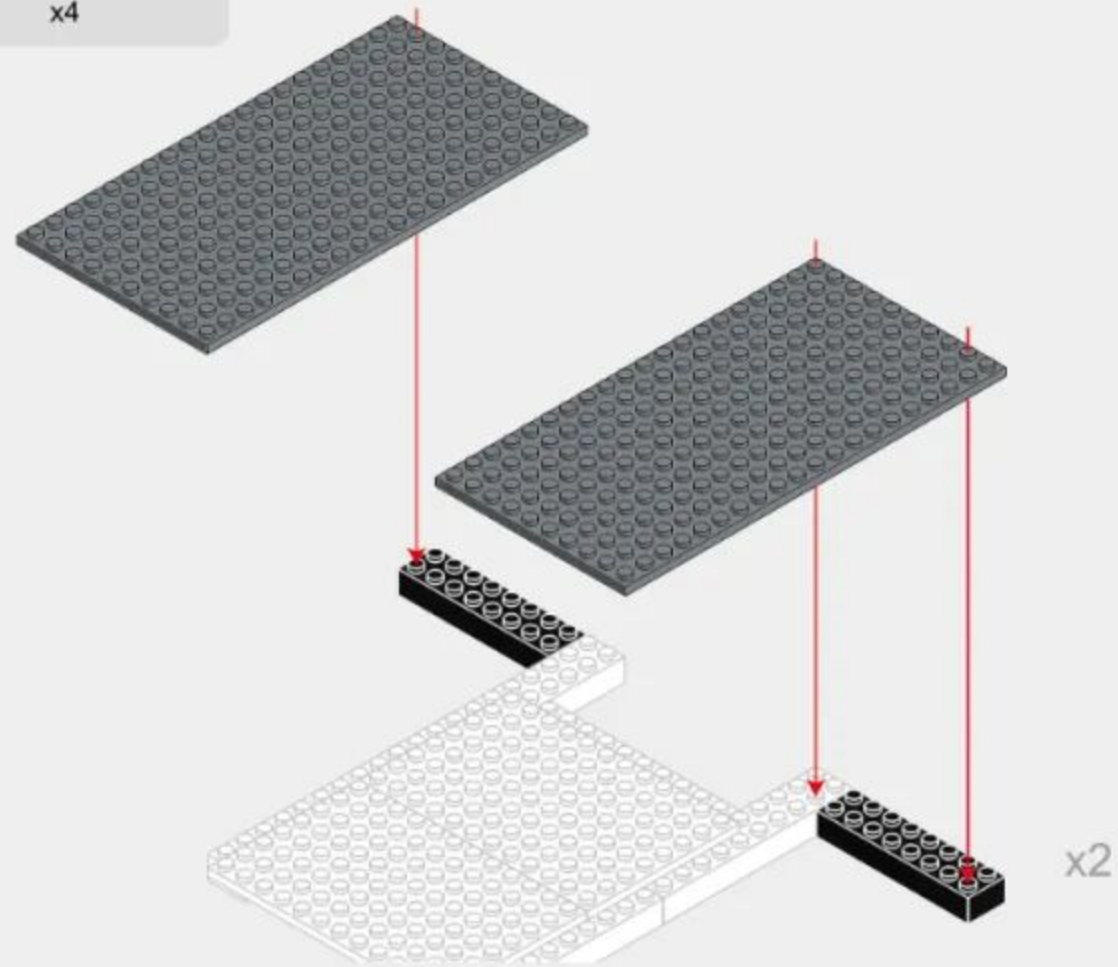
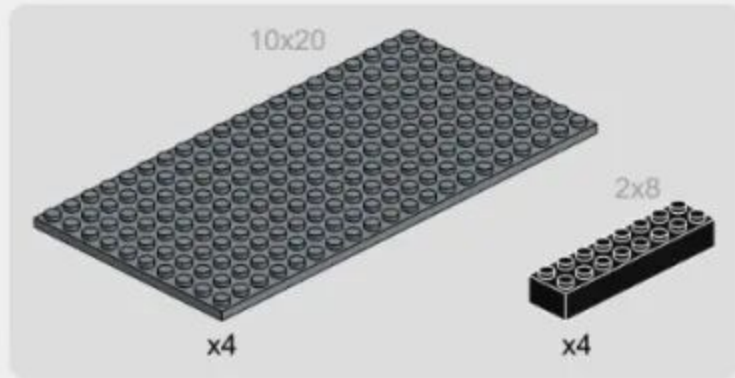

27

1-10

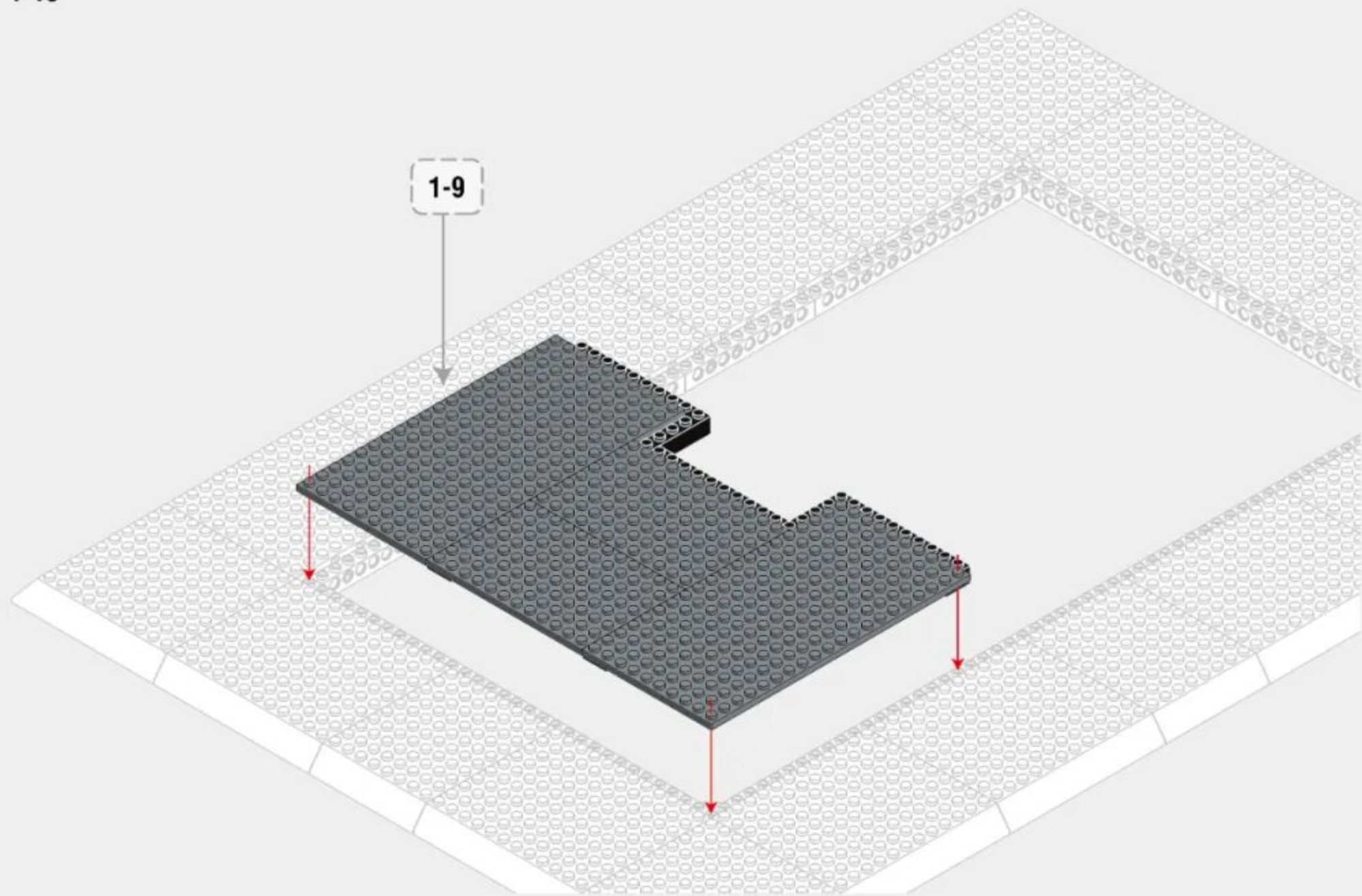

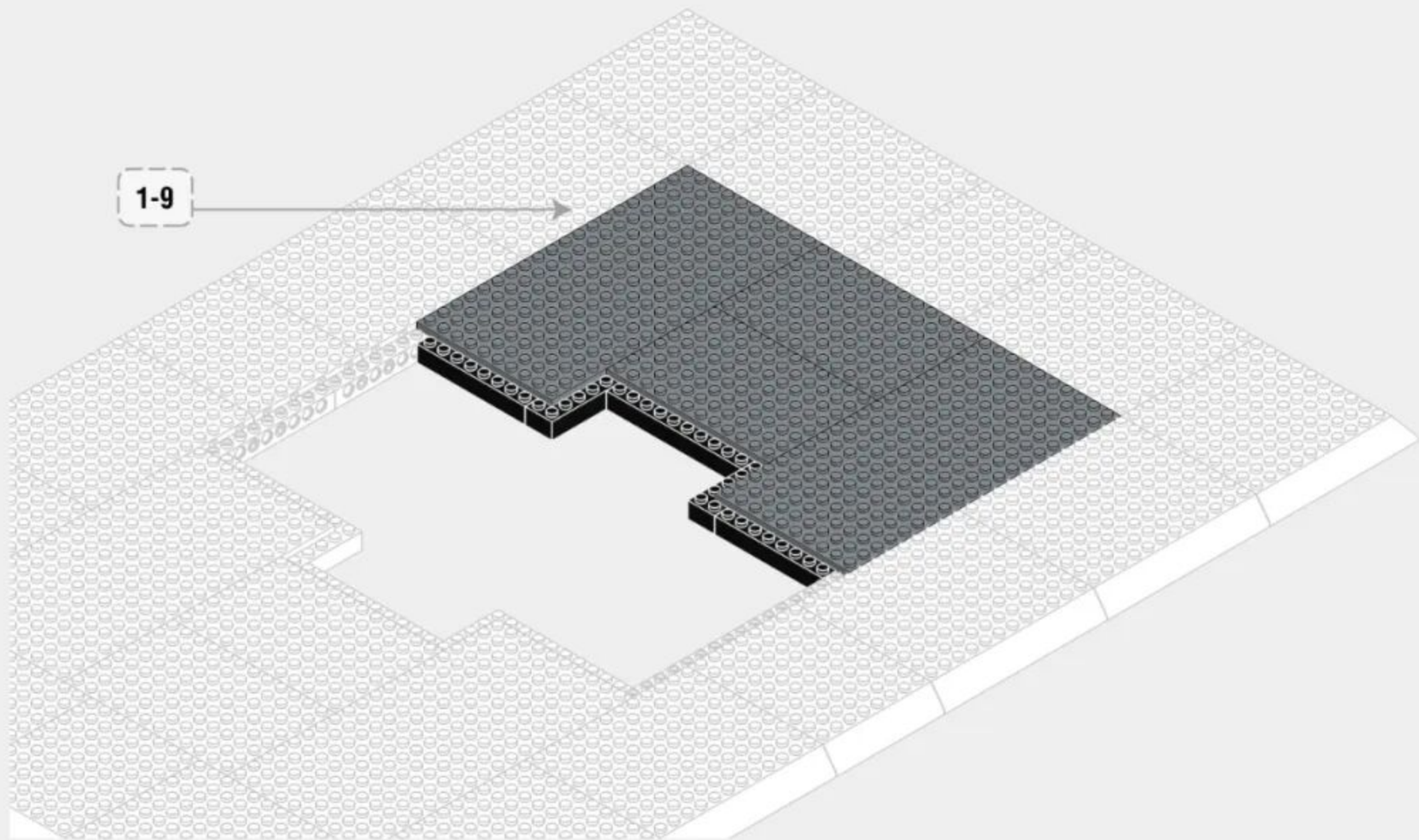

1-9

1-12

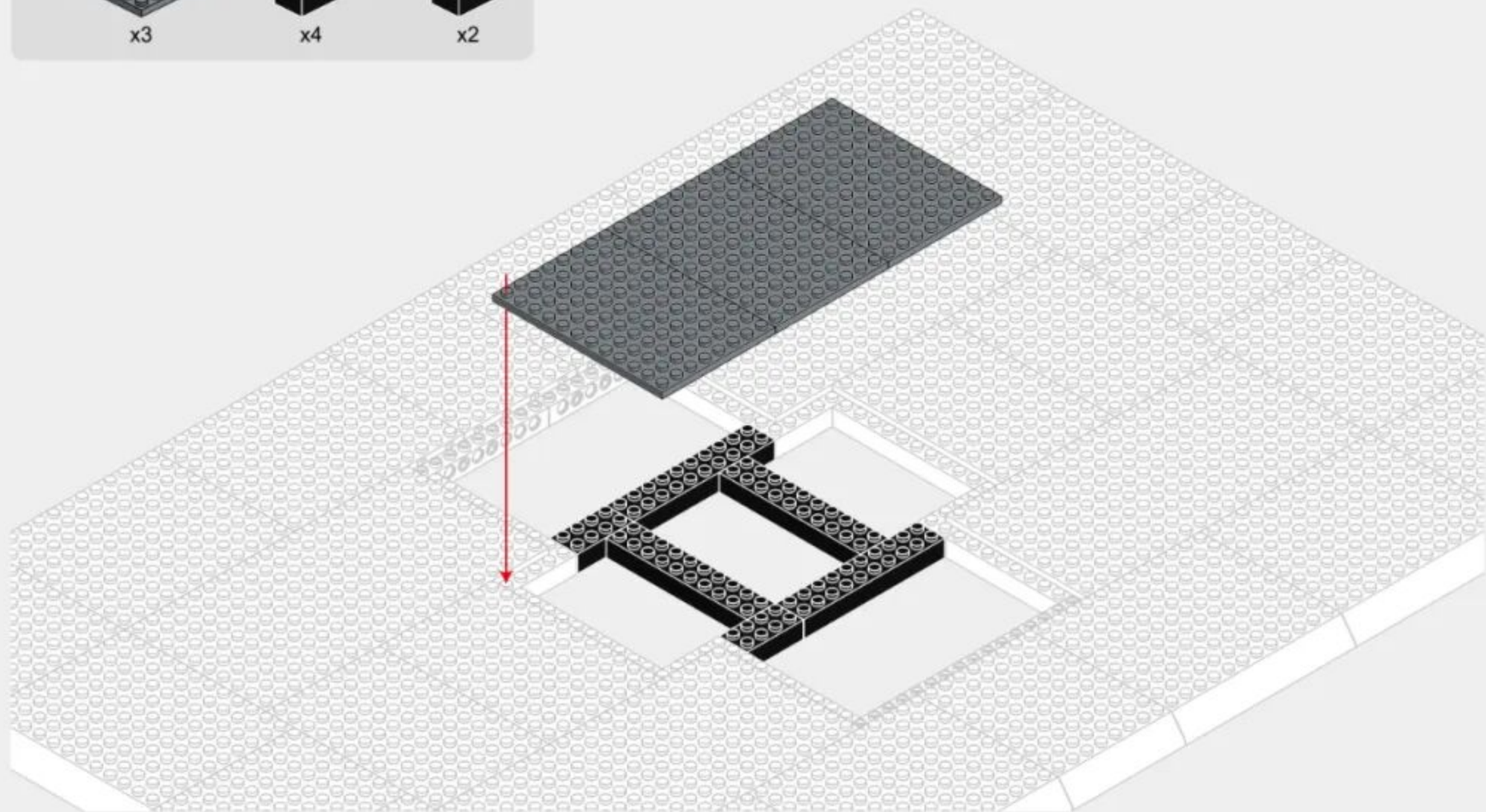
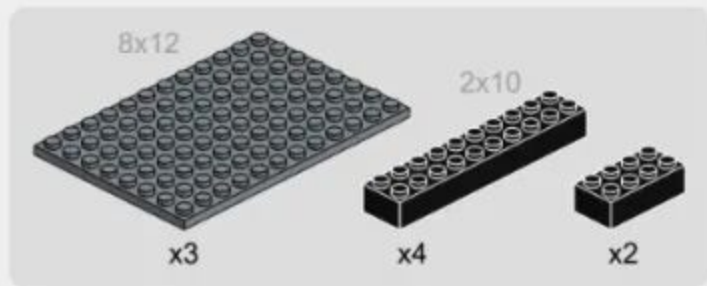

1-13

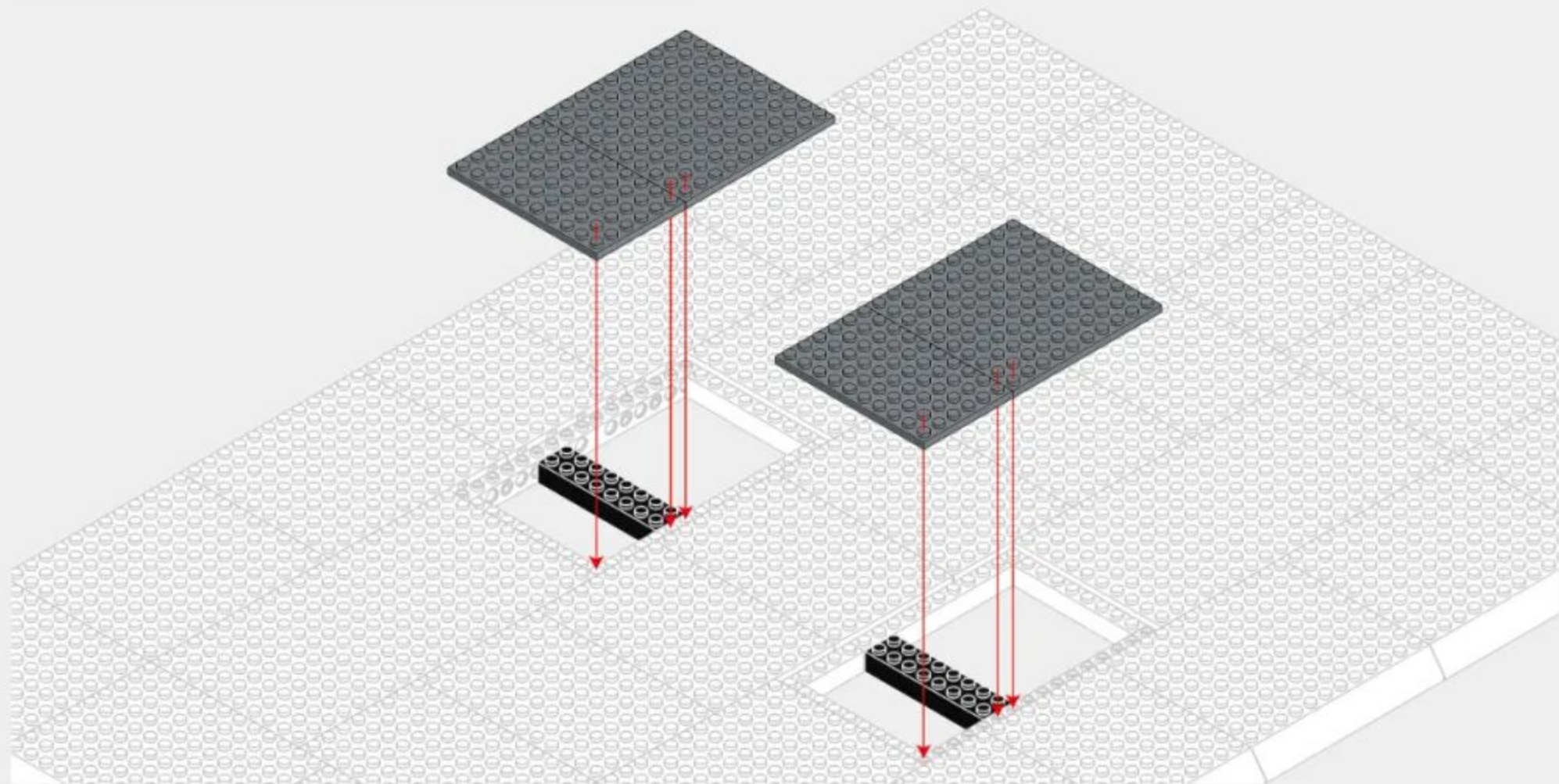
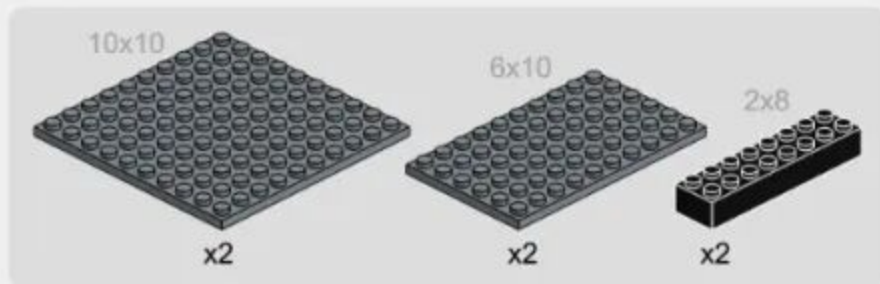

1-14

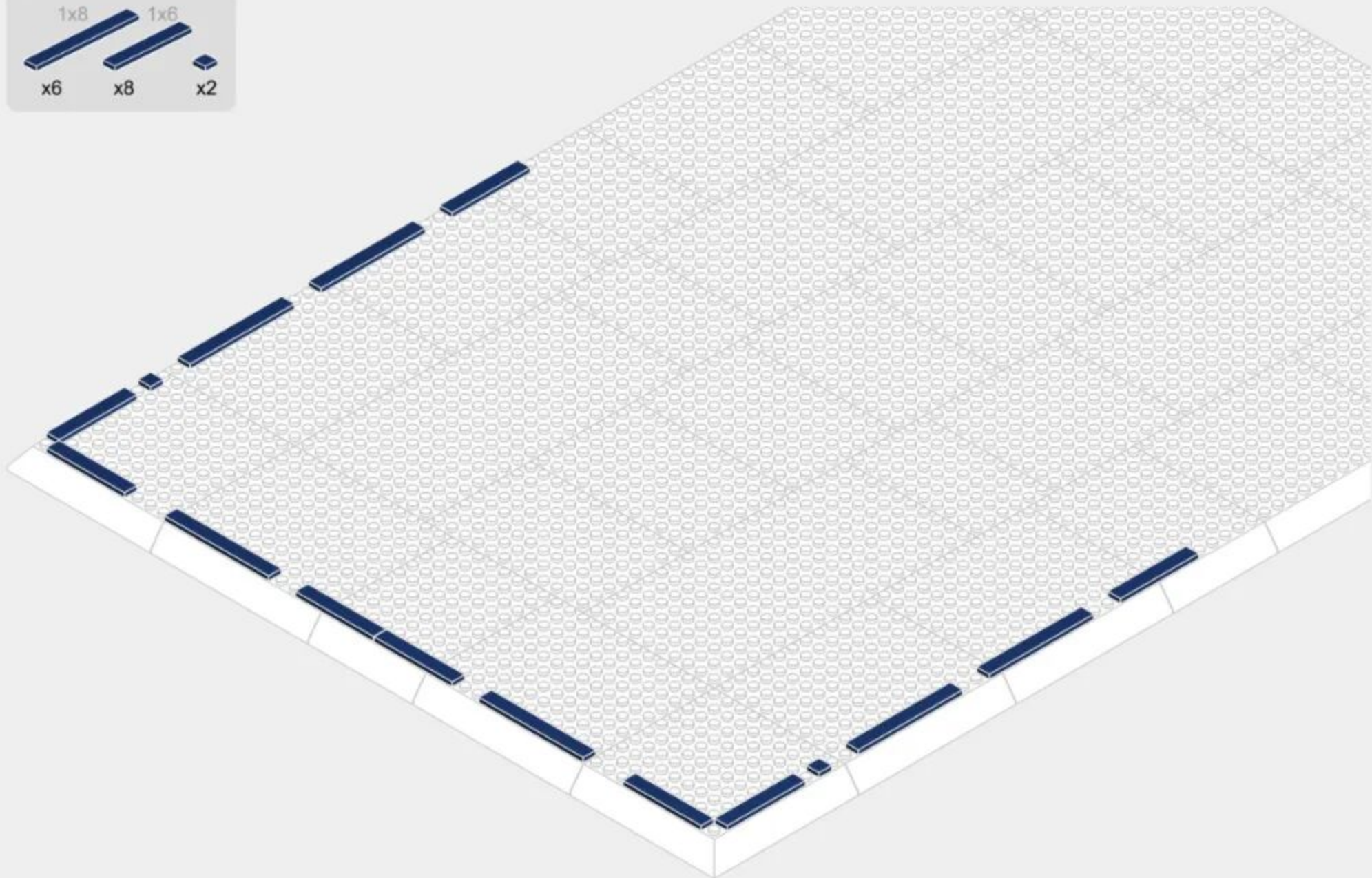

1-15

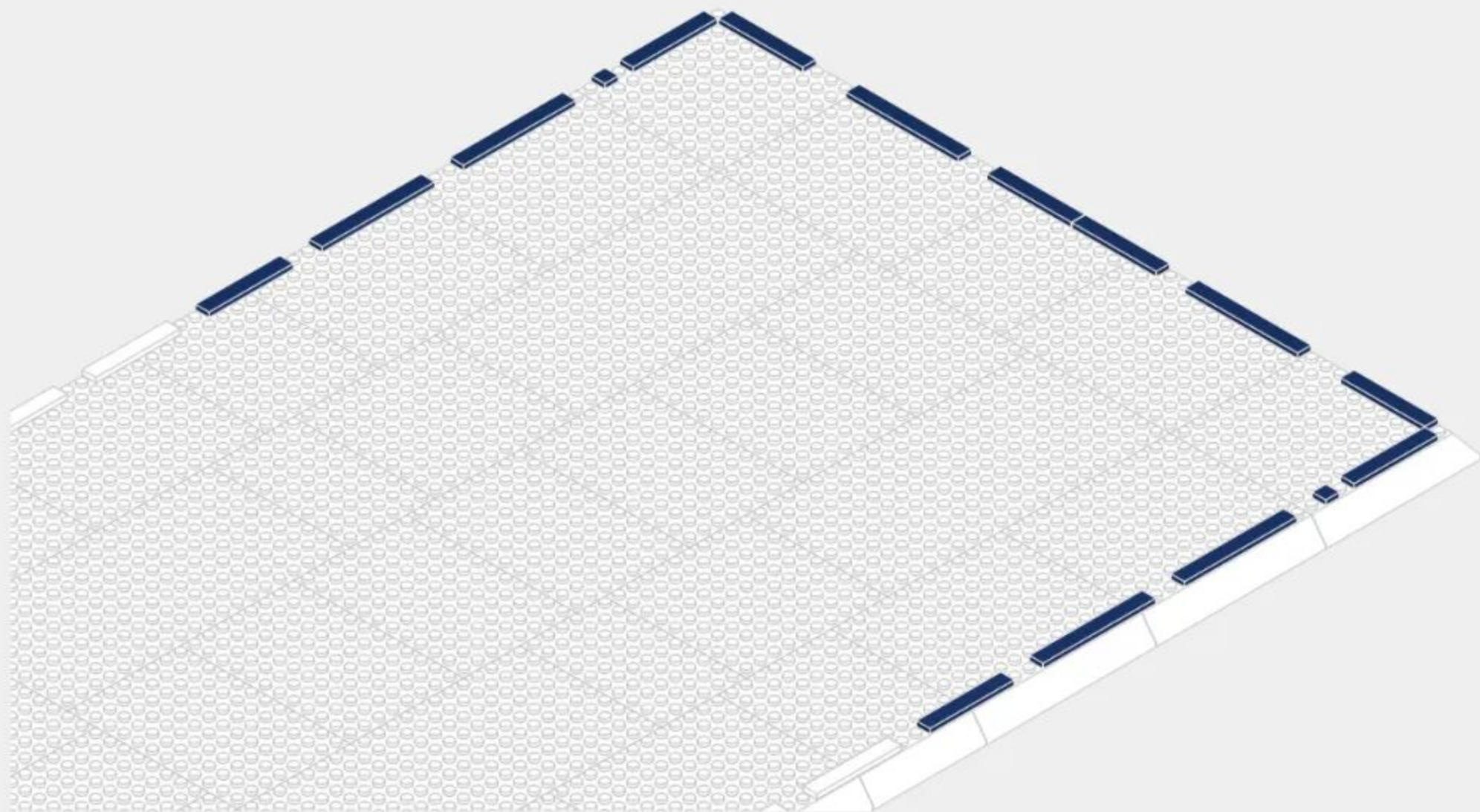

1-16

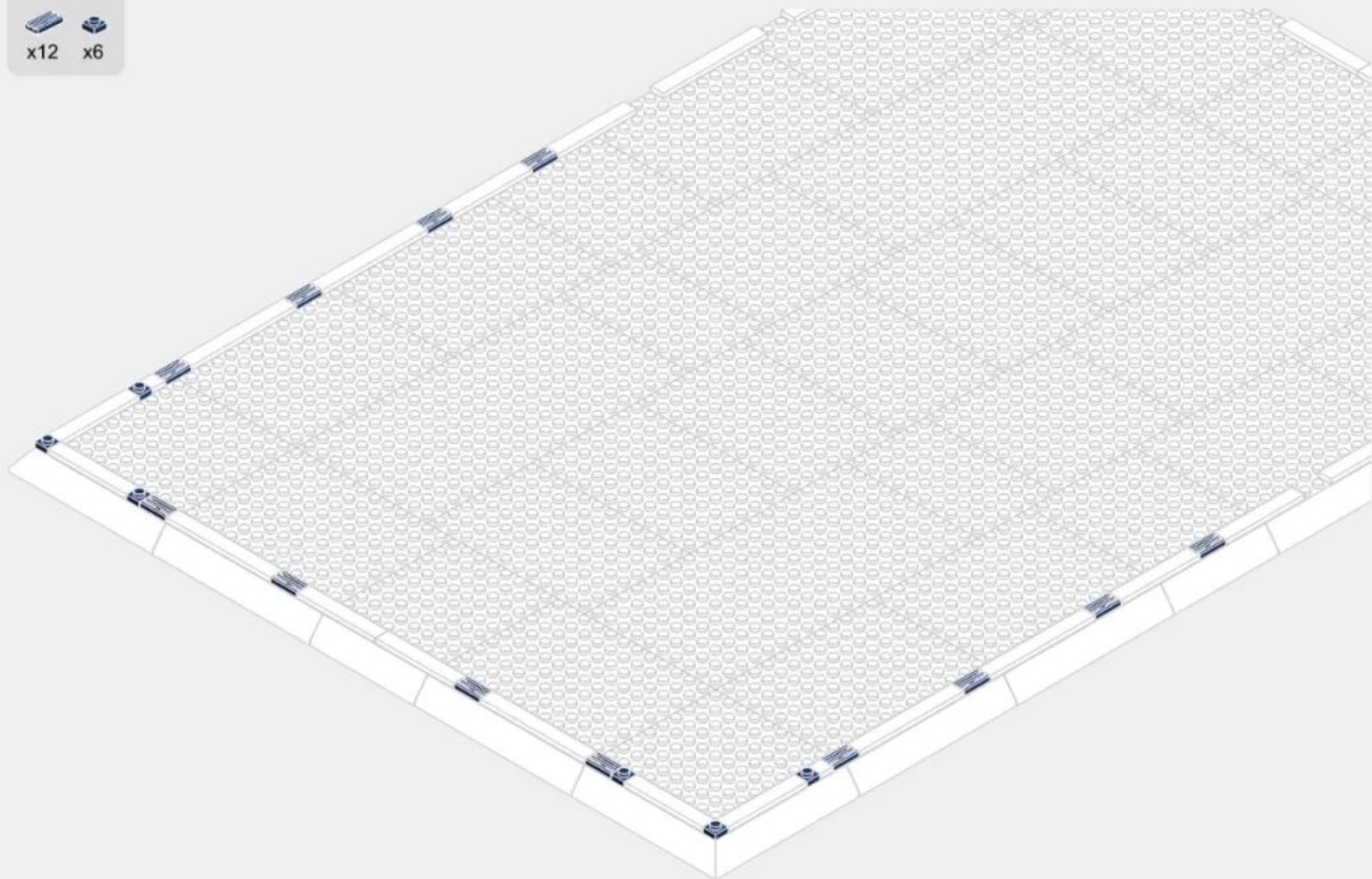

34

1-17

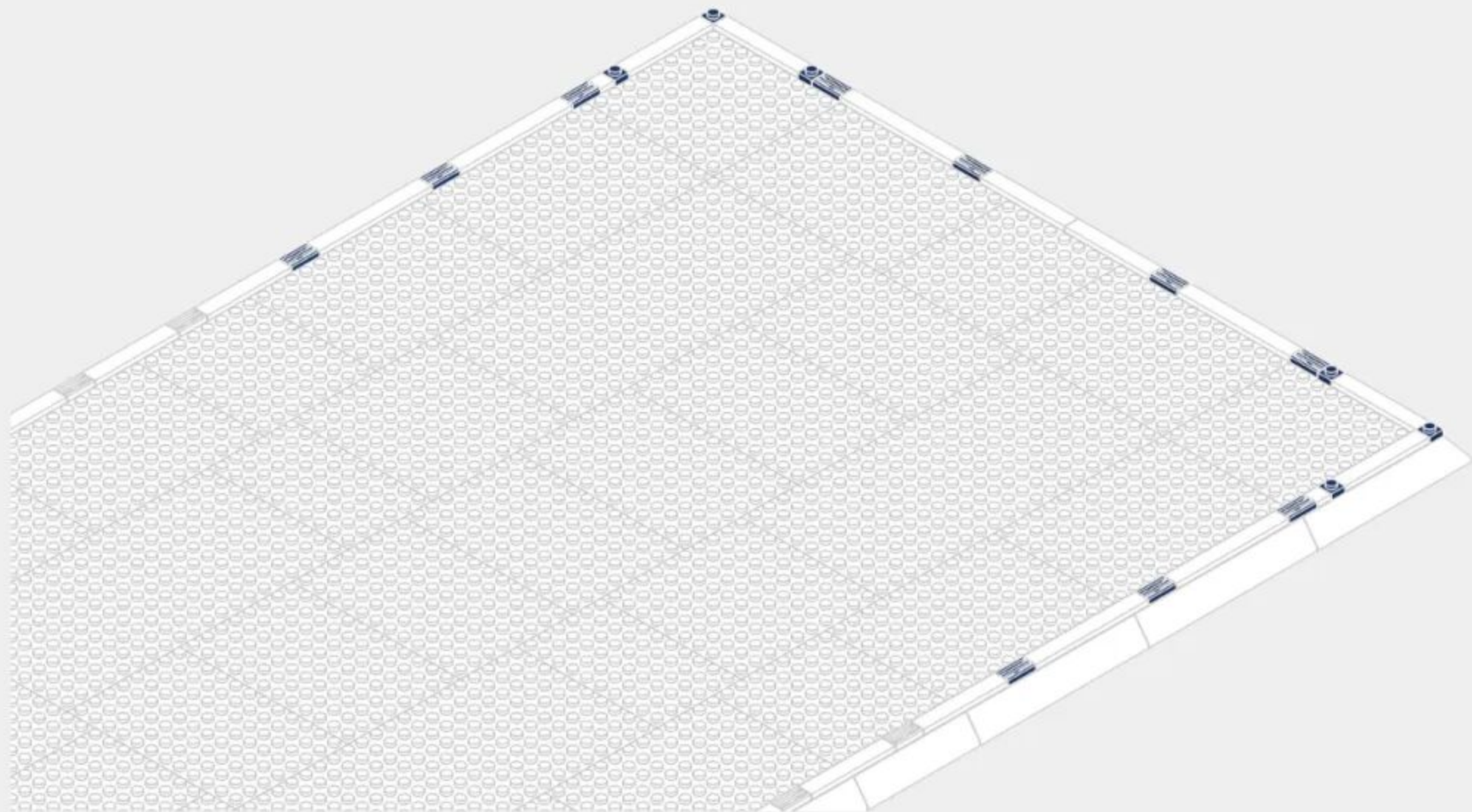

1-18

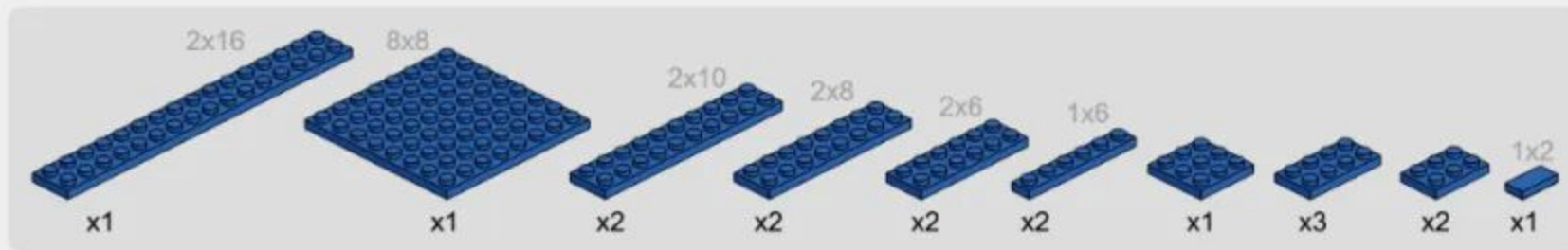

1-19

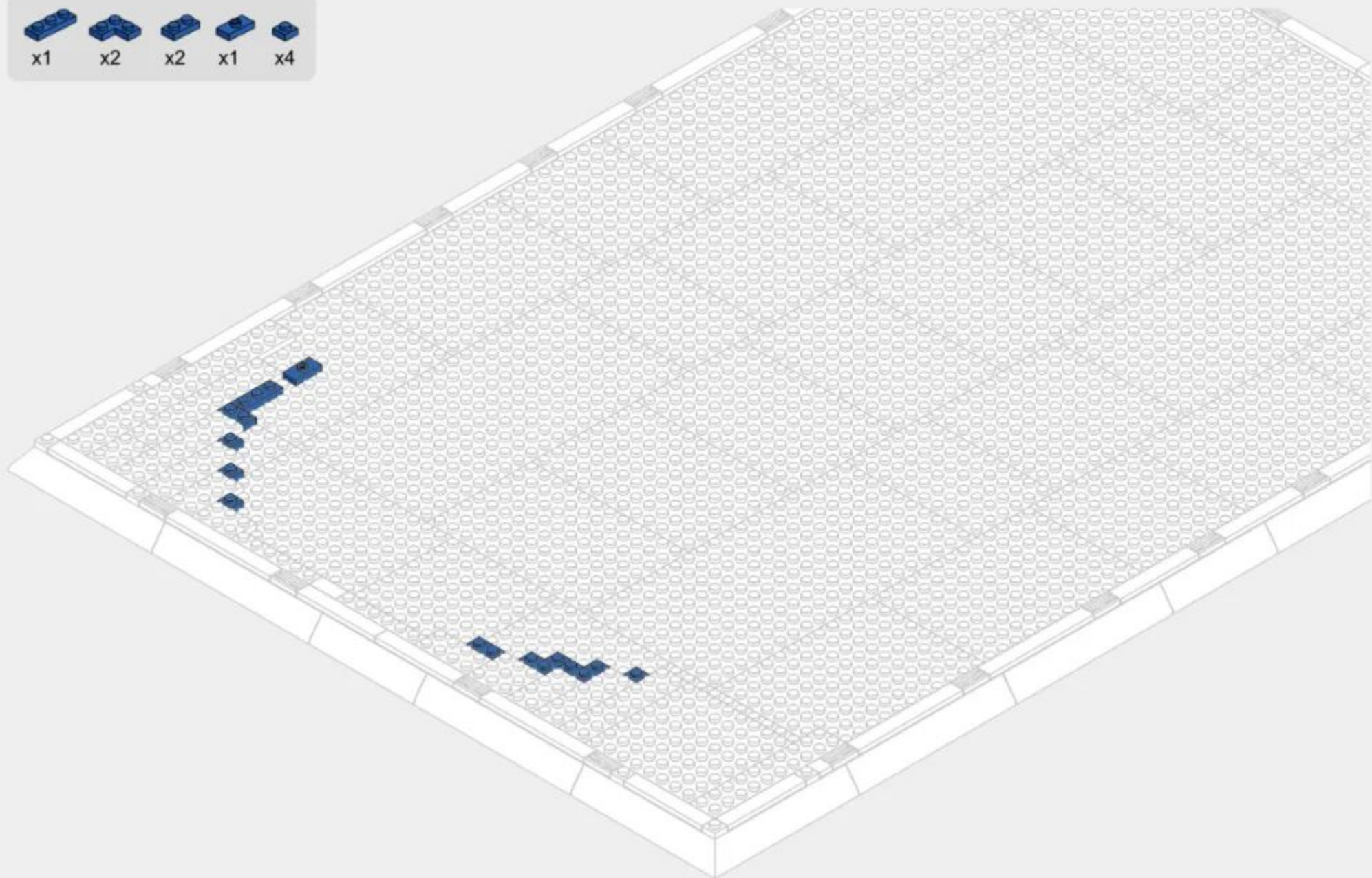

1-20

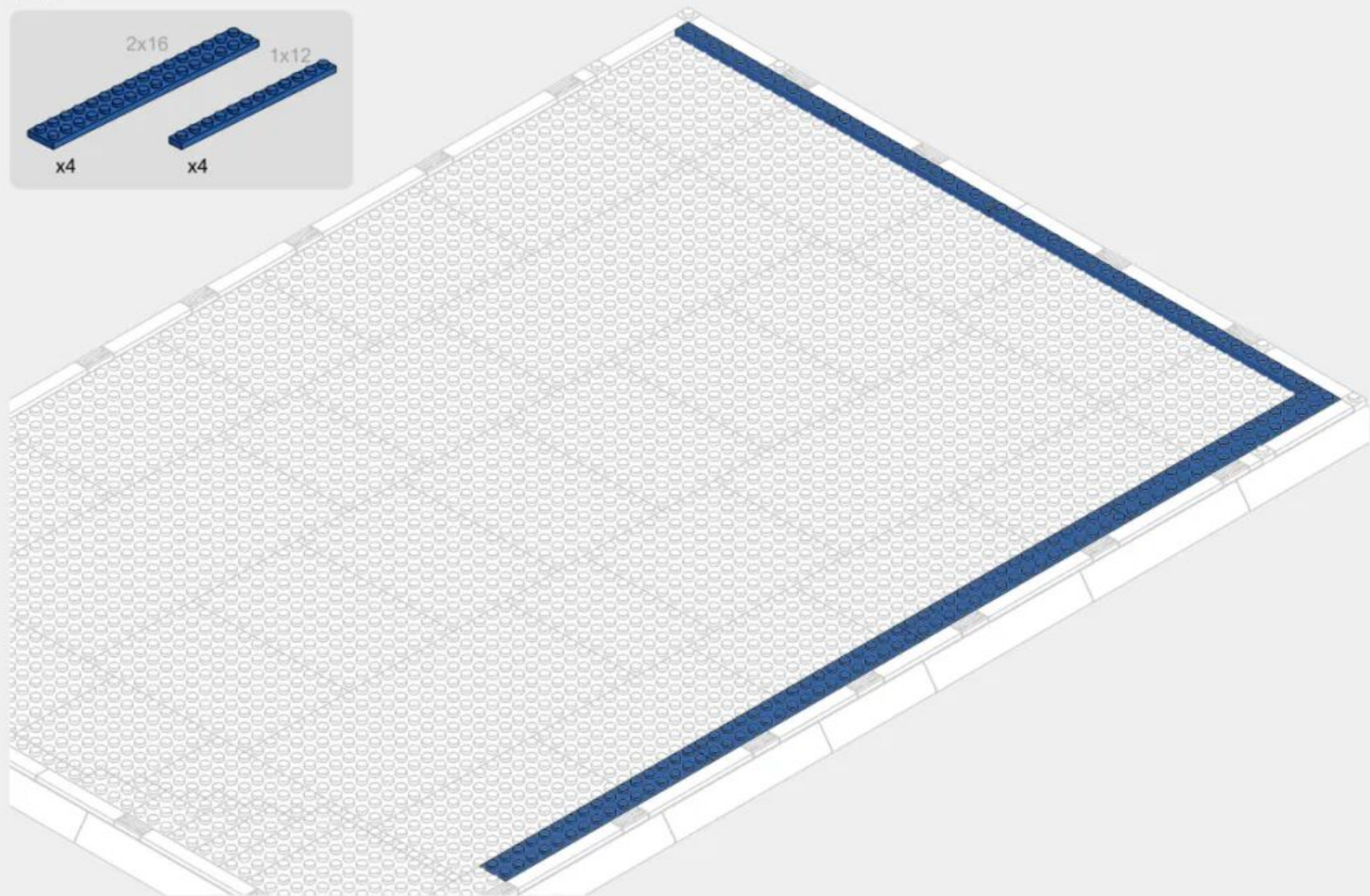
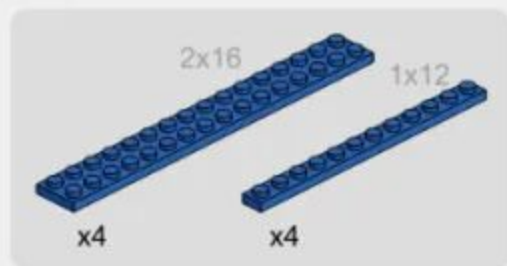

1-21

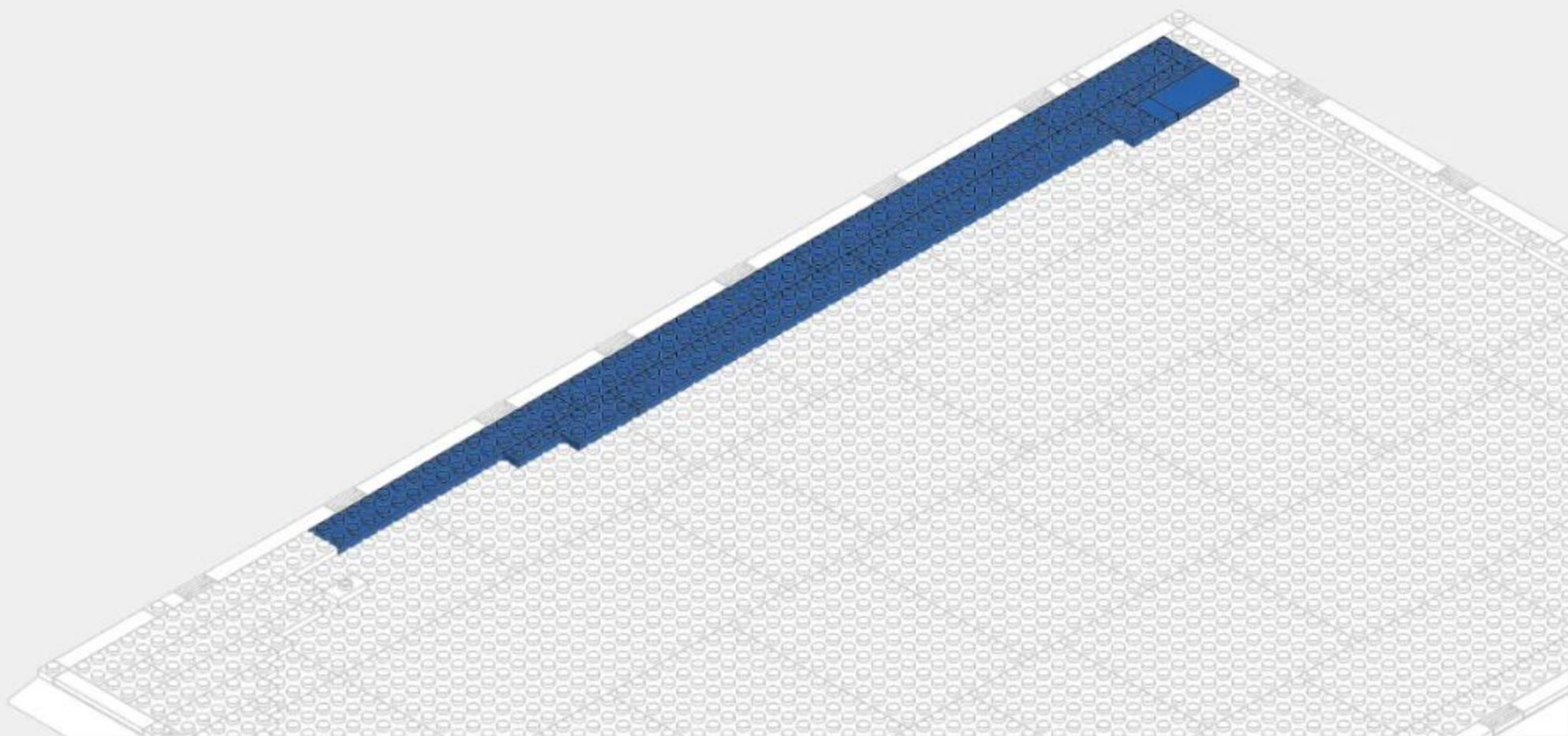
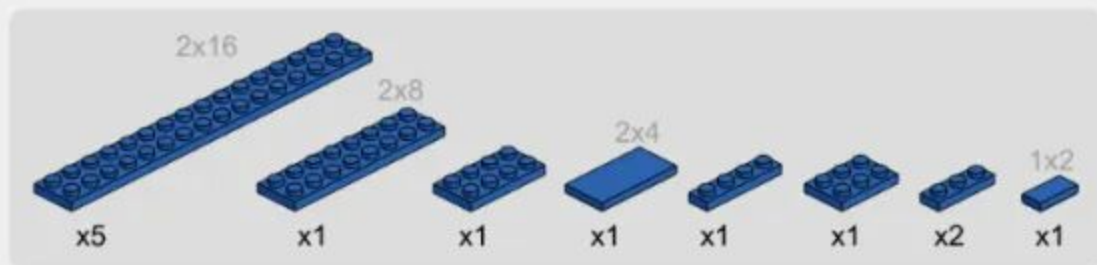



285PCS



40

2-1

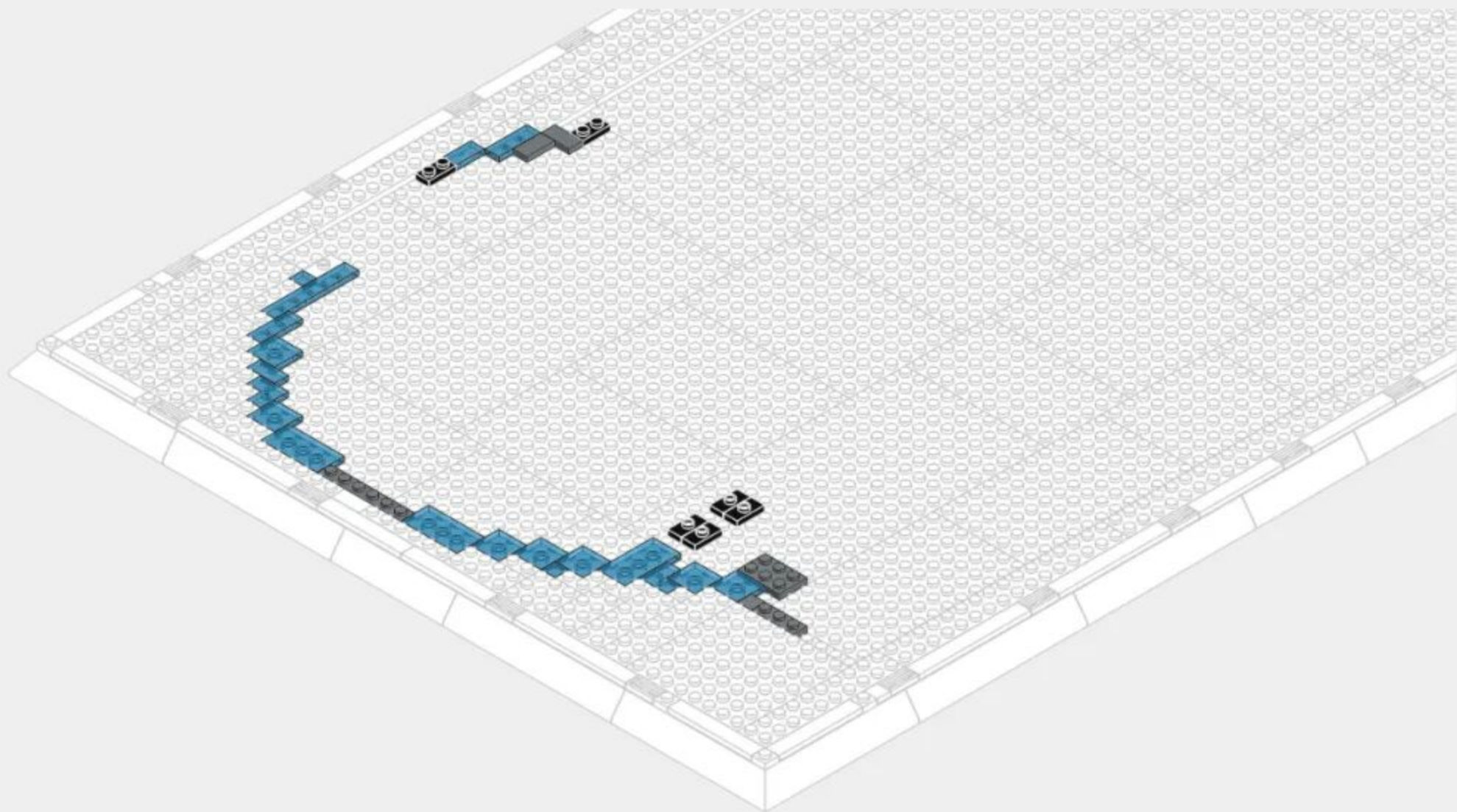

2-2

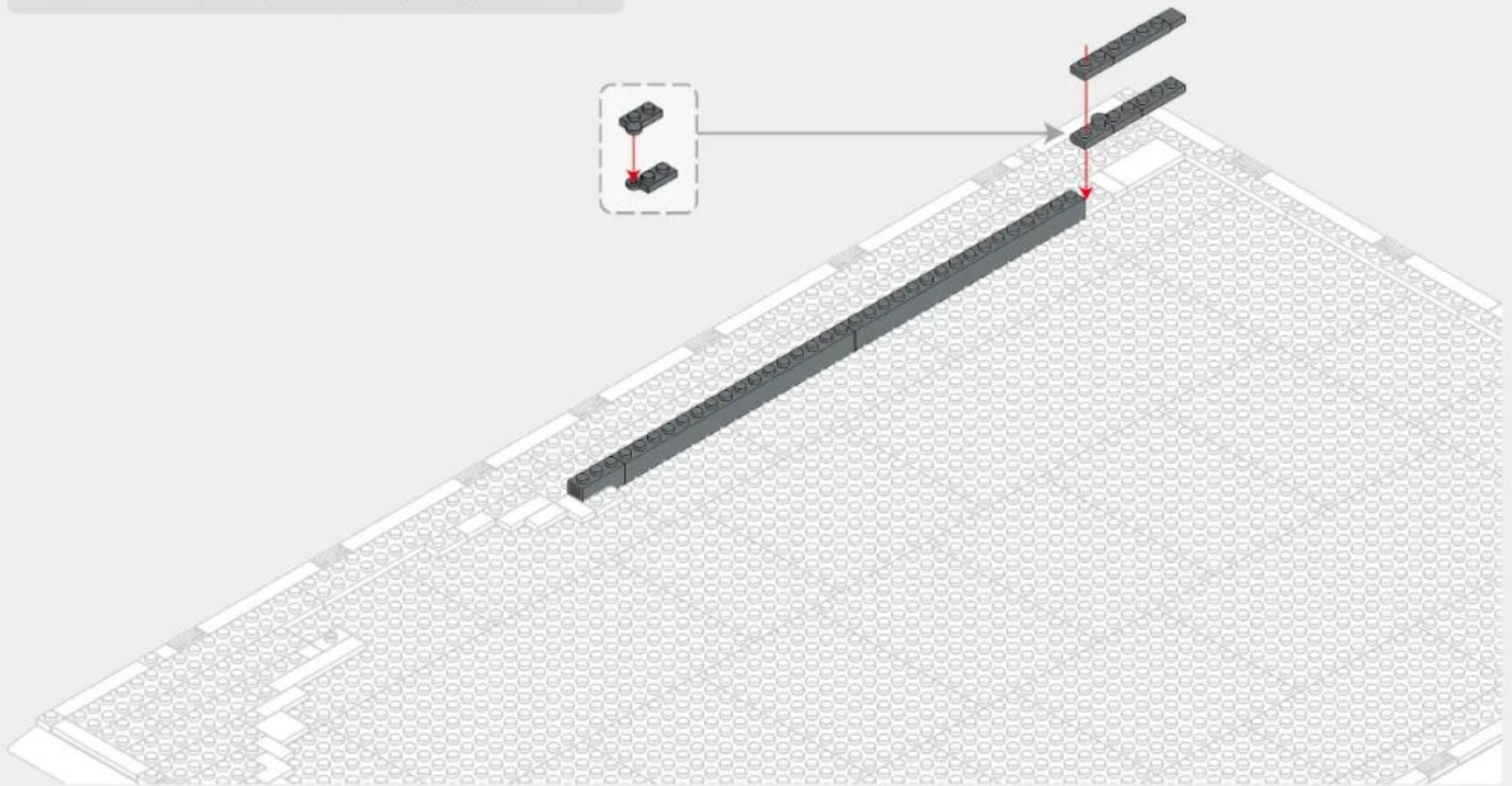
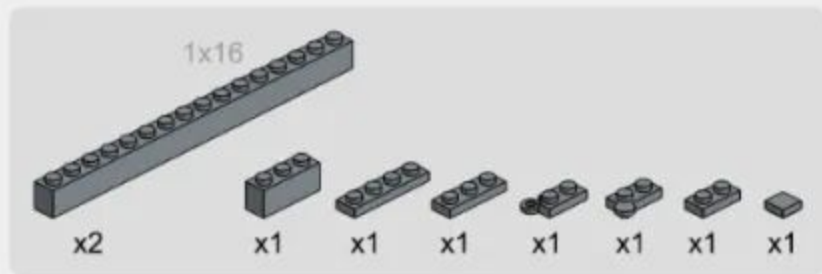

2-3

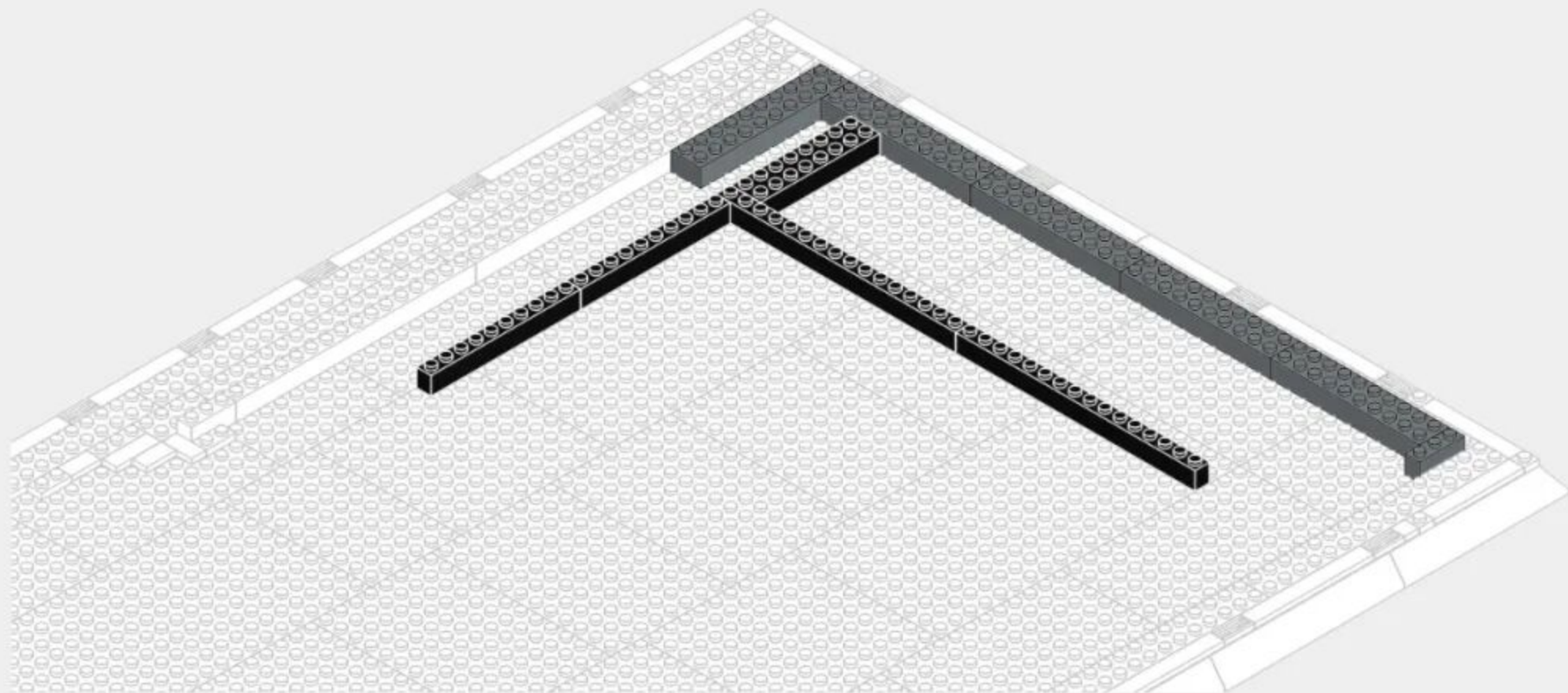
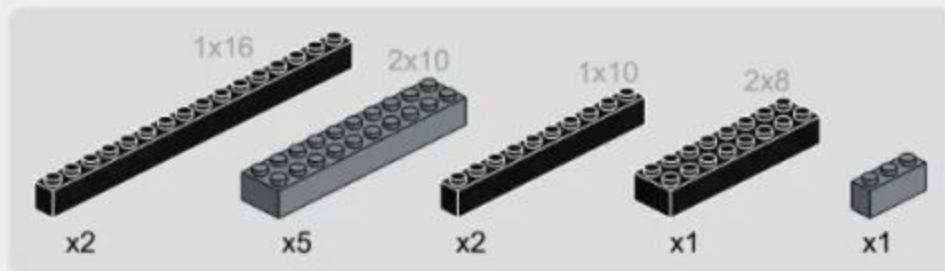

2-4

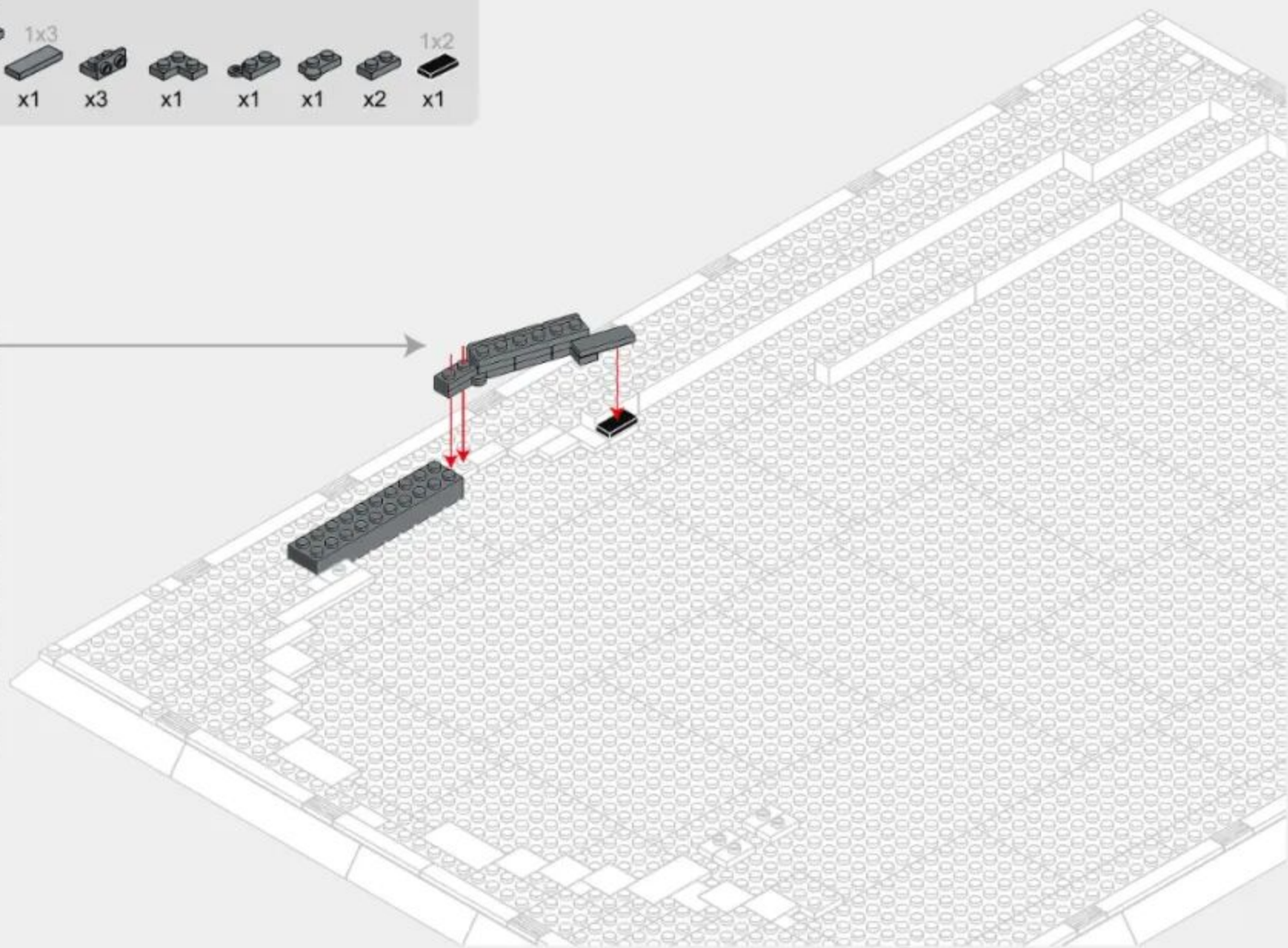
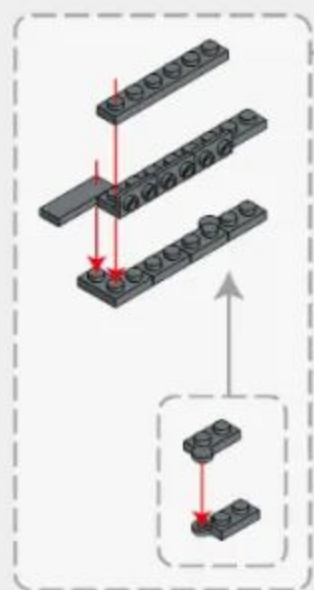
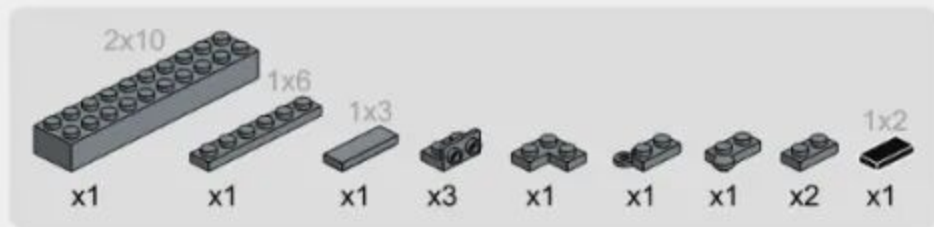

2-5

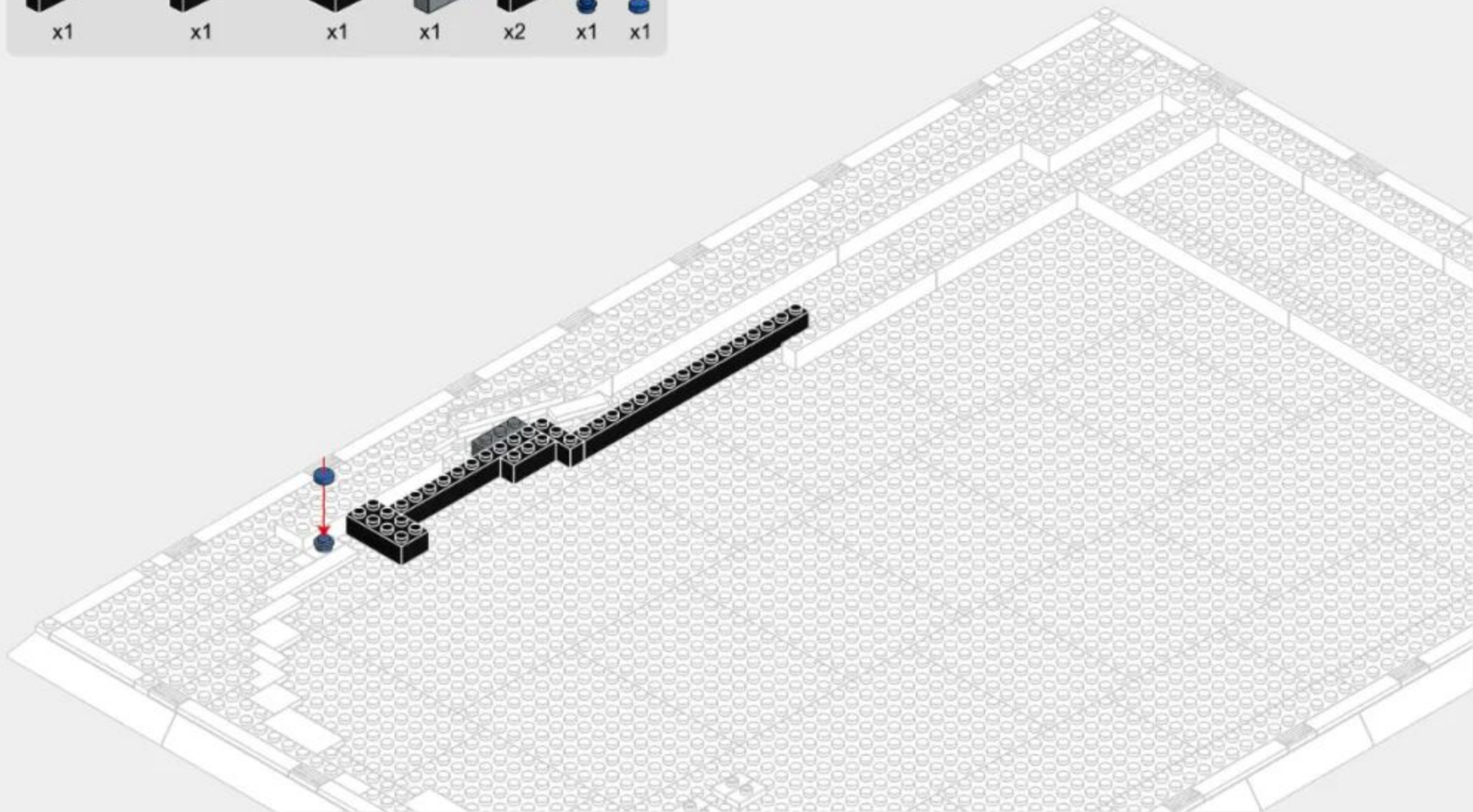
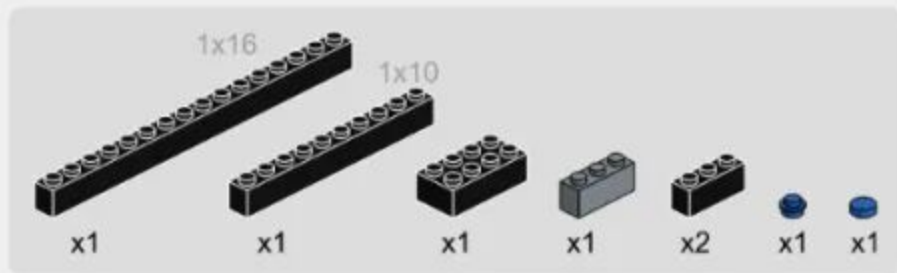

2-6

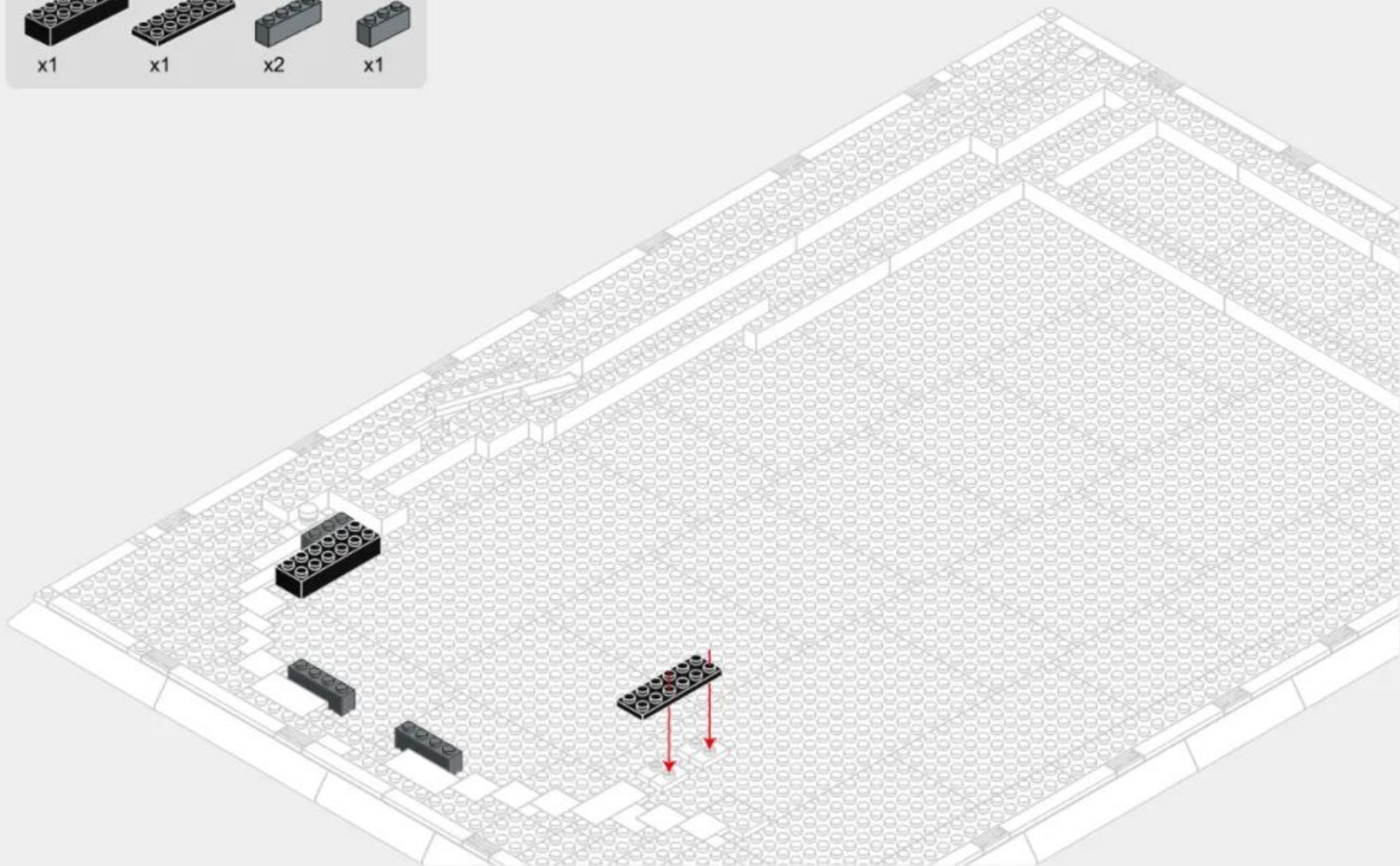
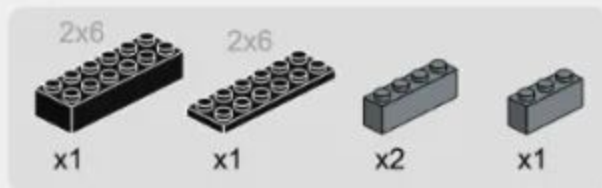

2-7

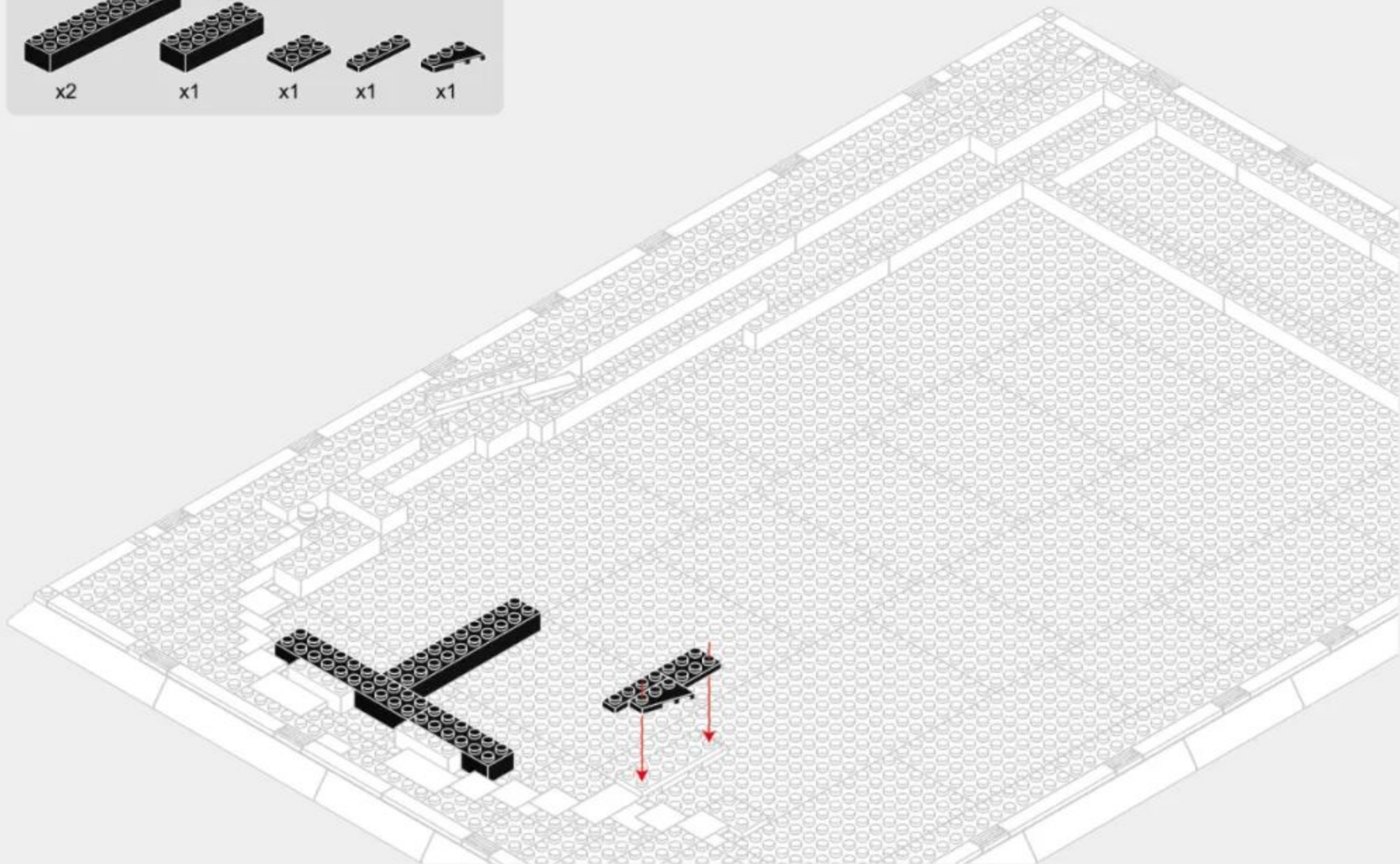
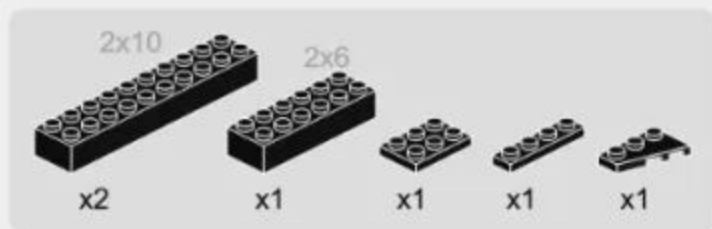

2-8

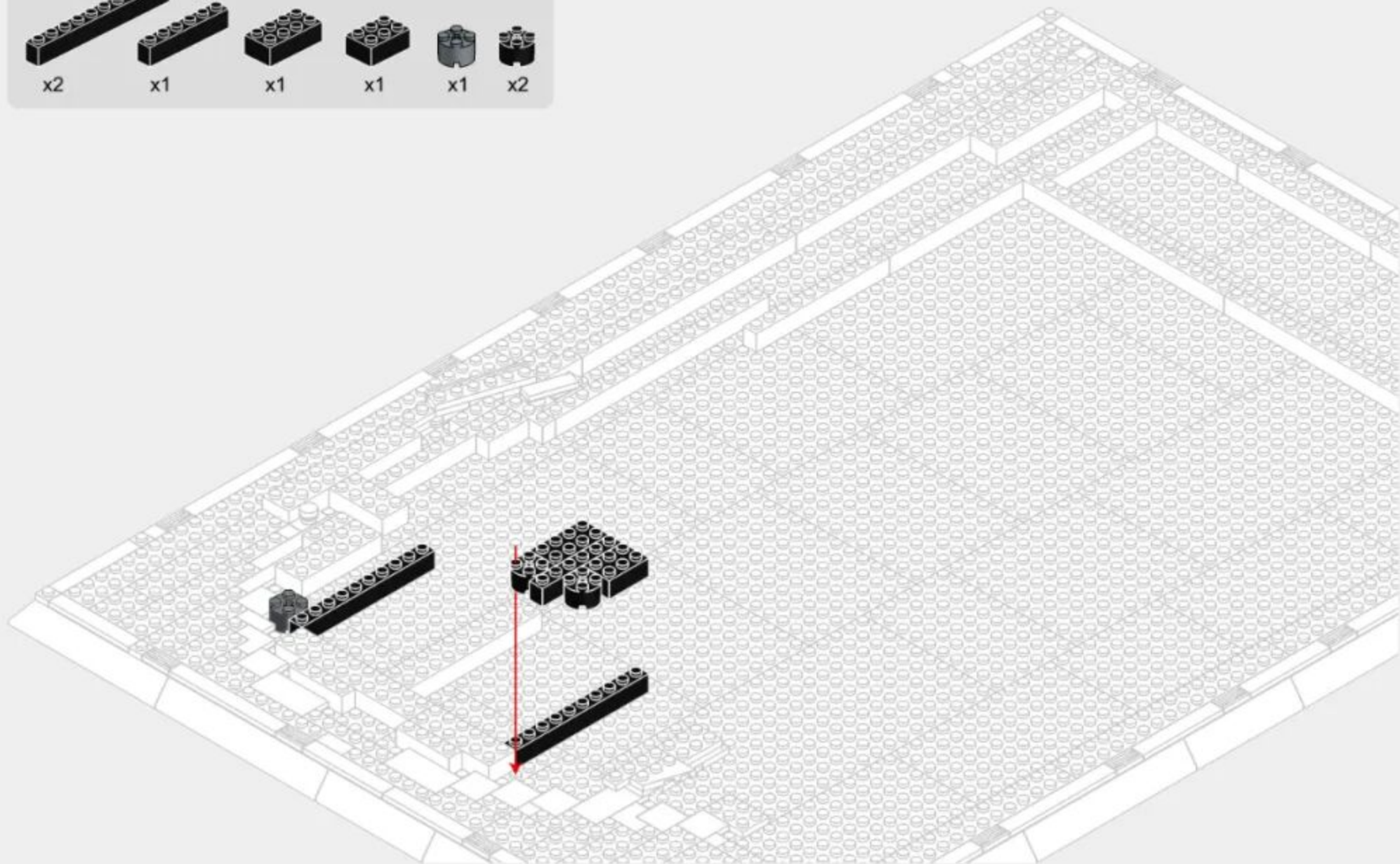
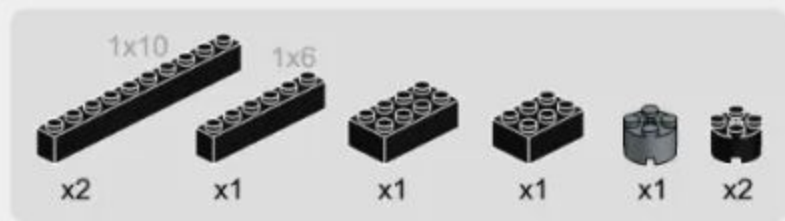

2-9

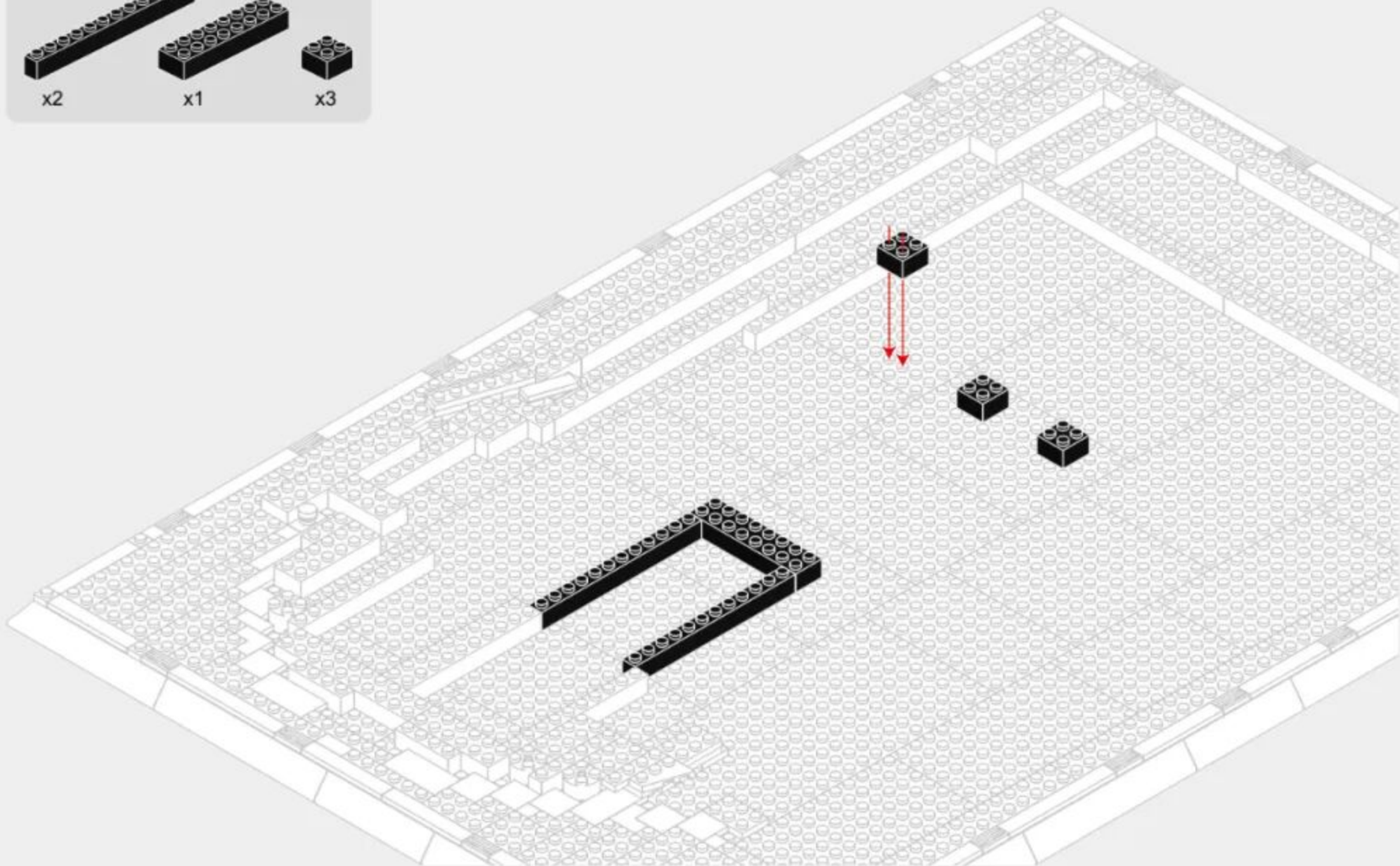
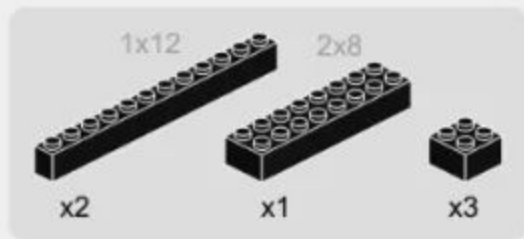

2-10

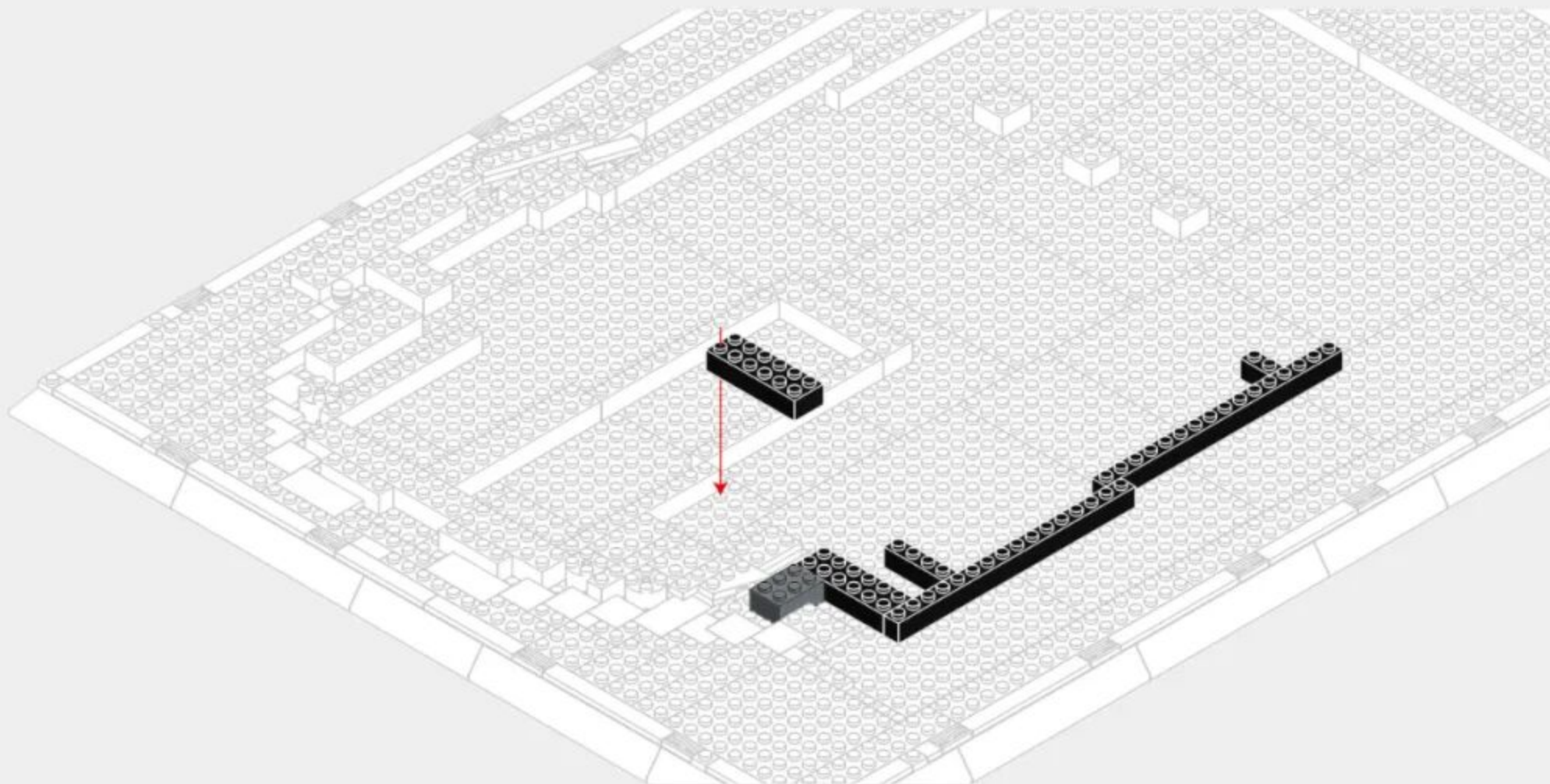
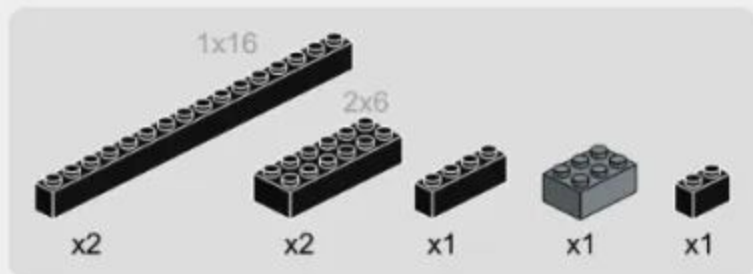

2-11

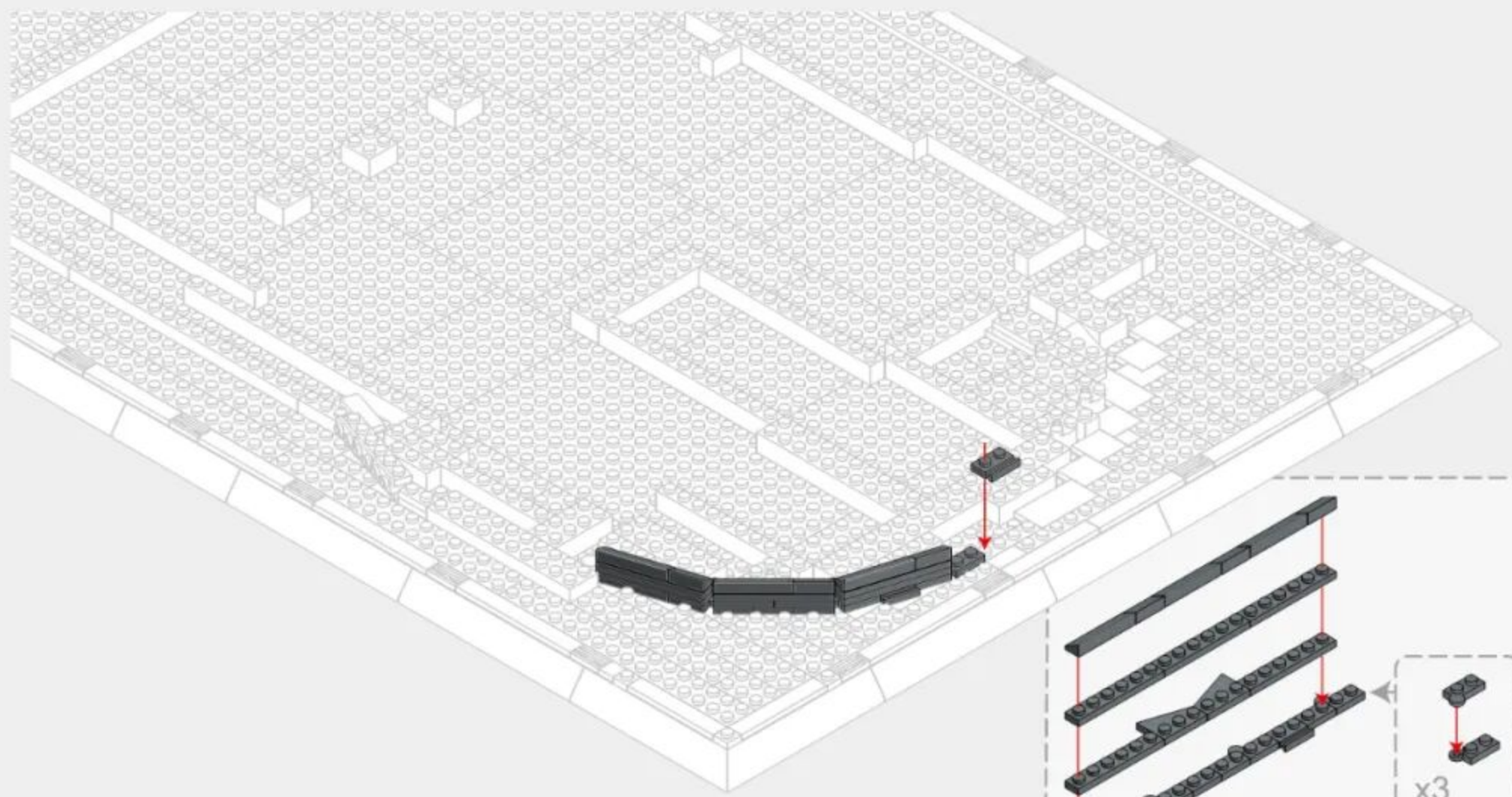
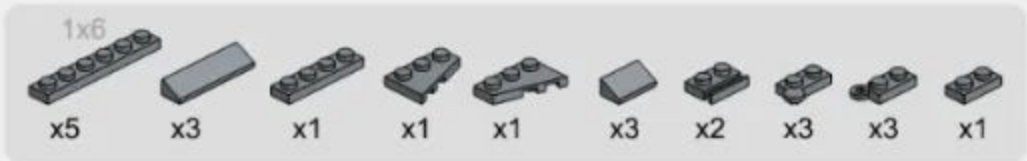

51

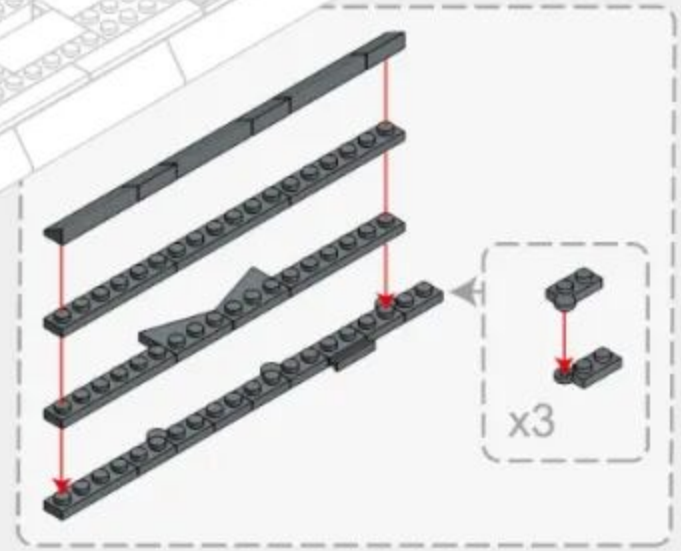

x3

2-12

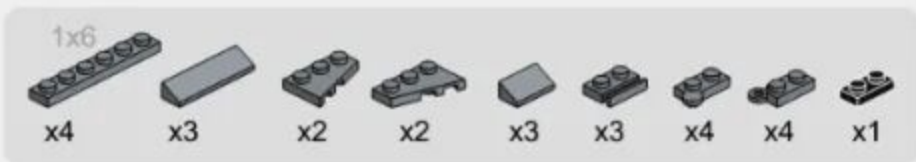

52

2-13

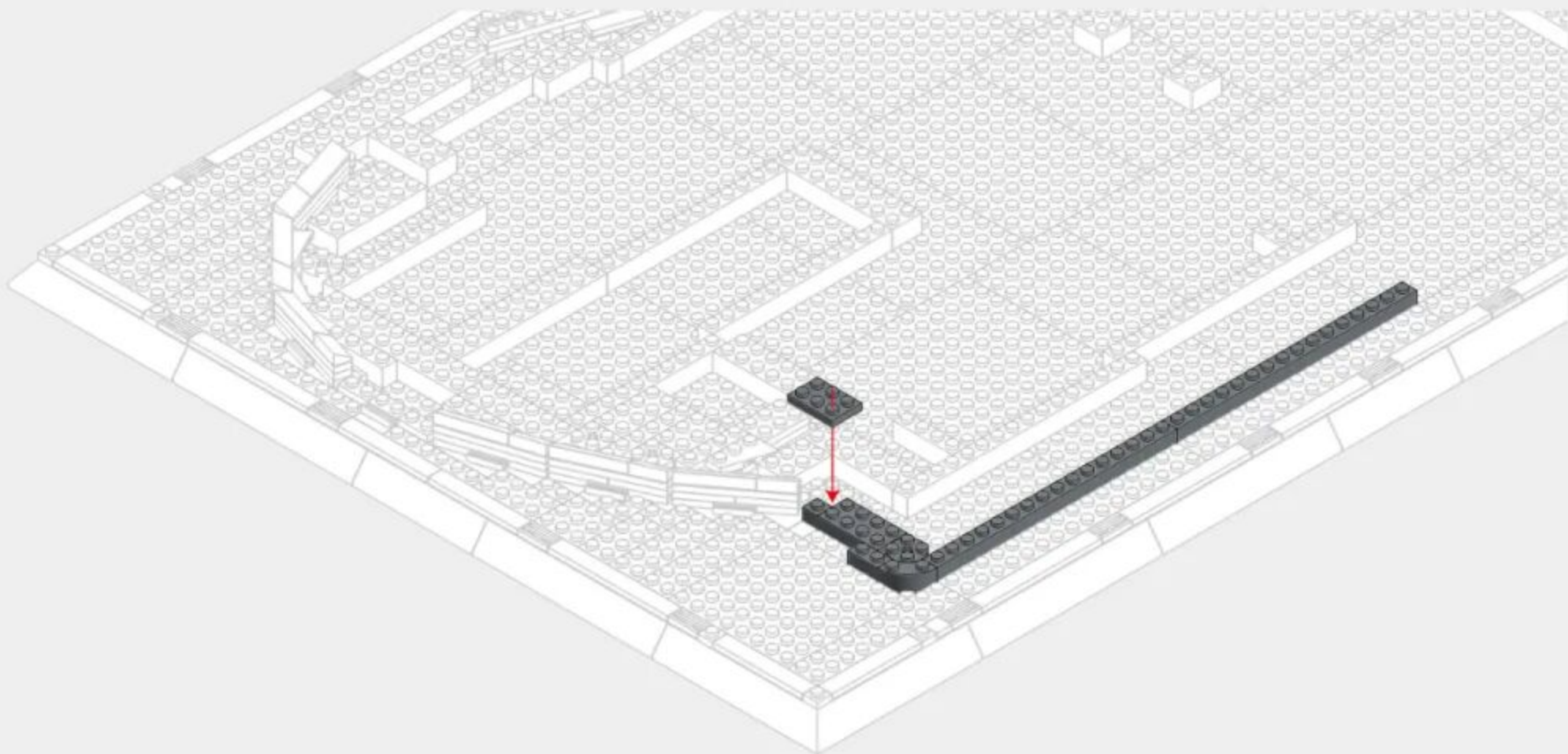
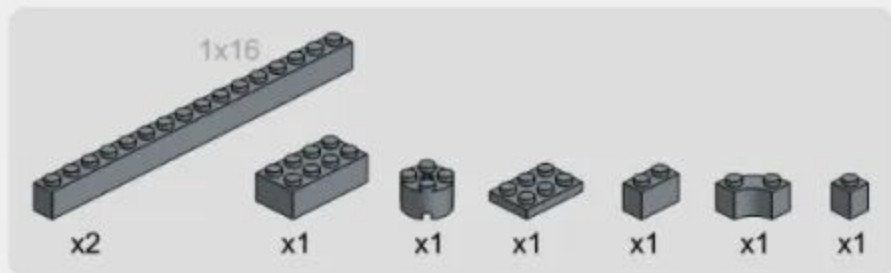

2-14

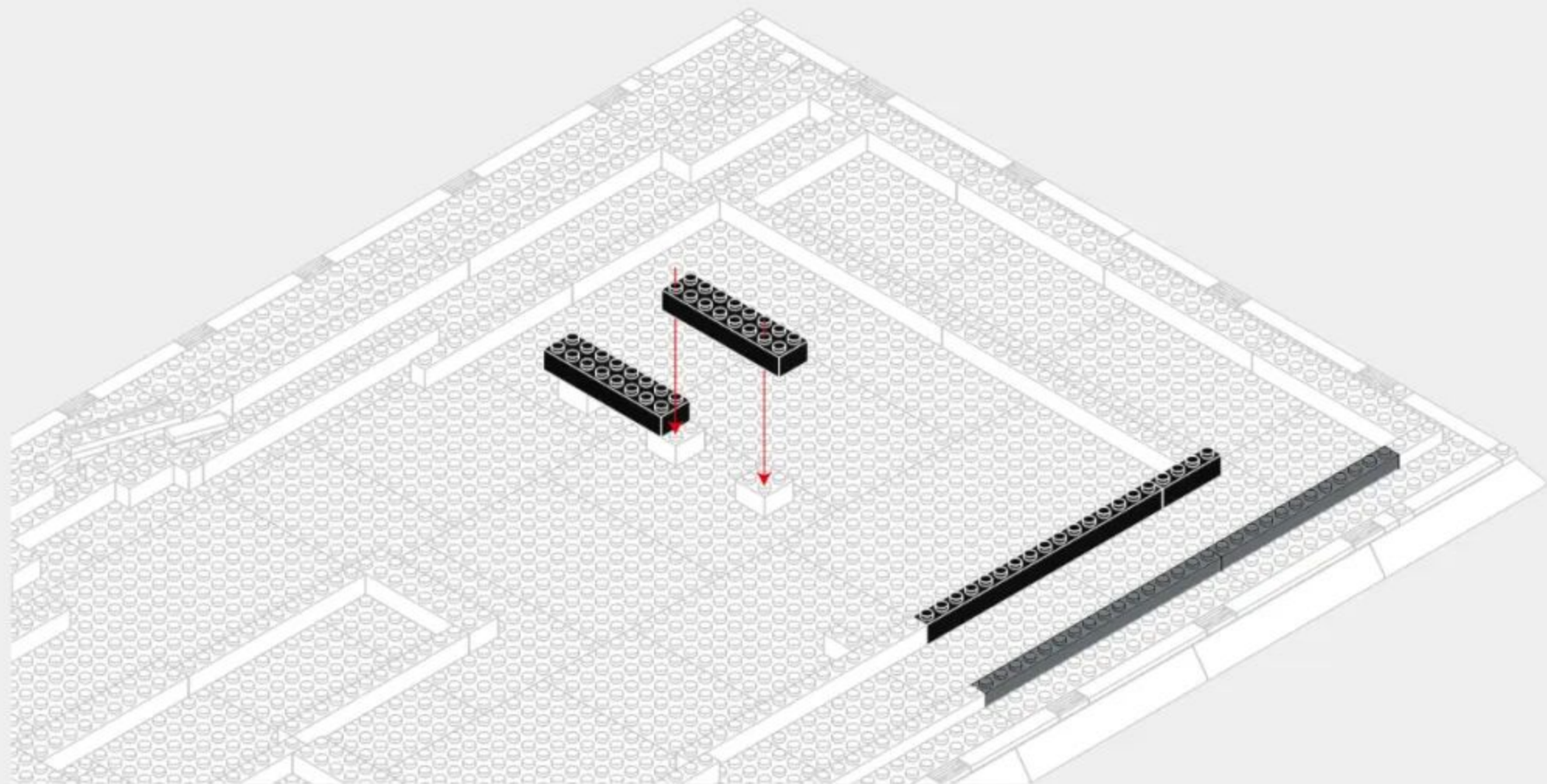
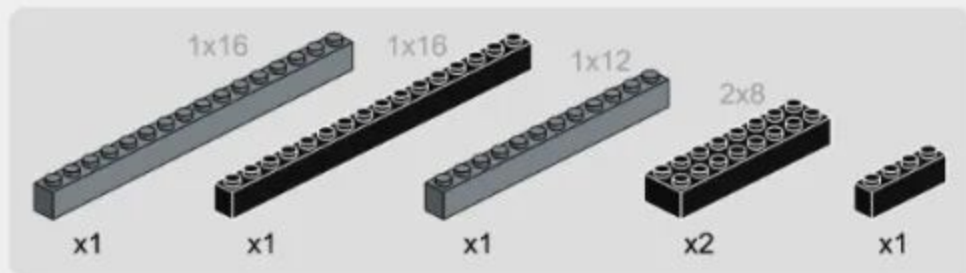

2-15

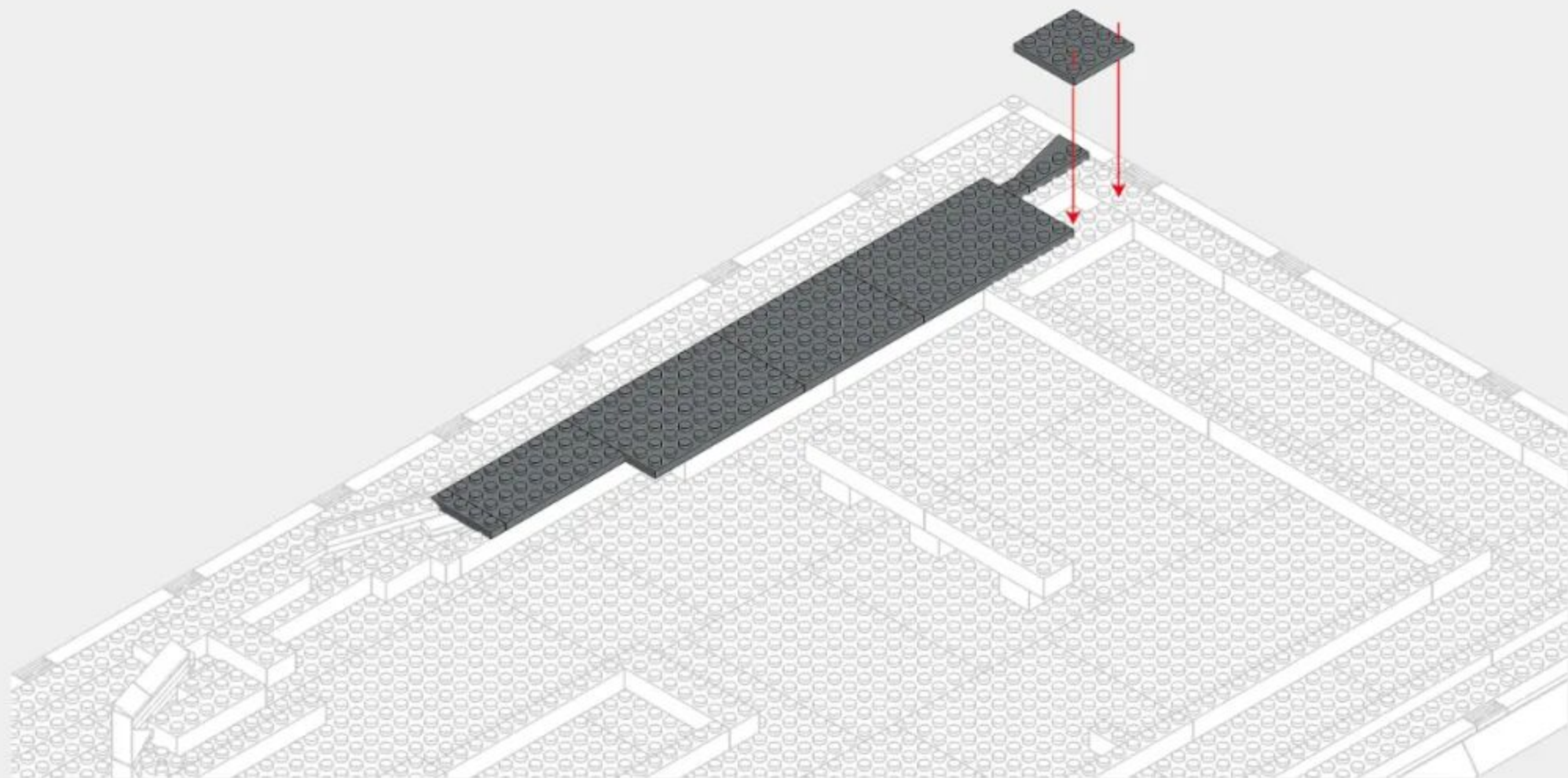
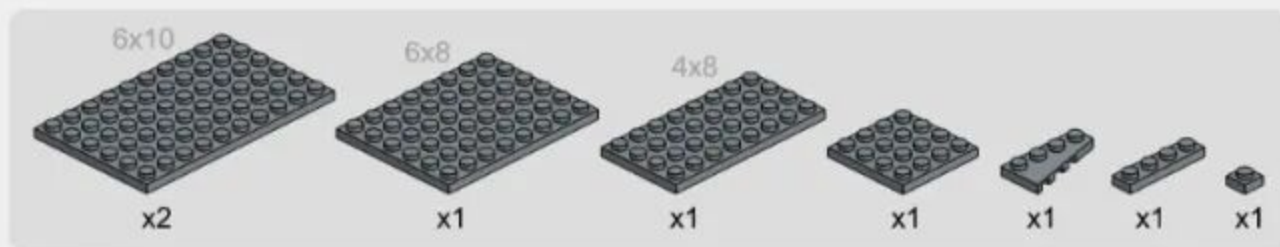

2-16

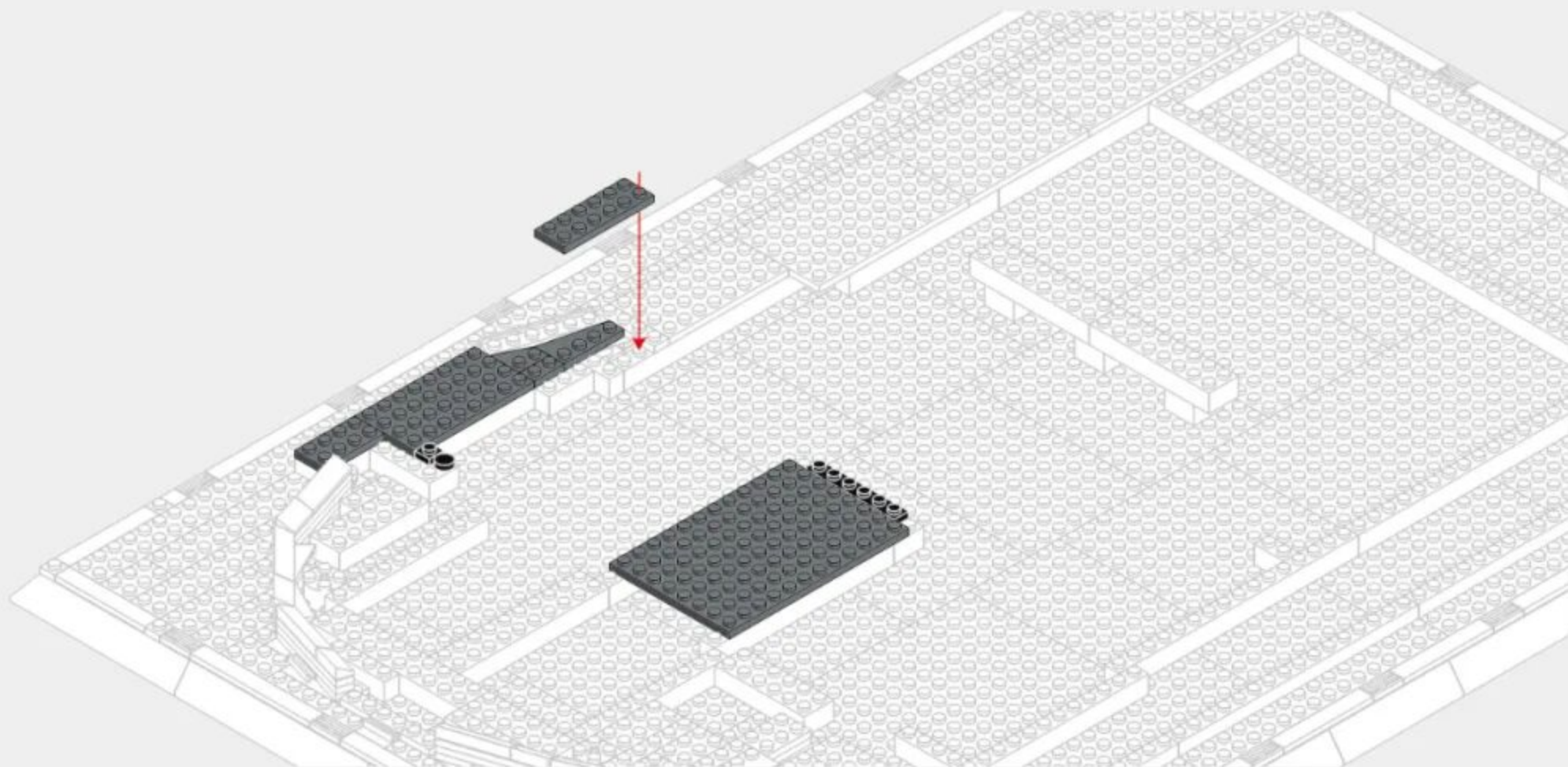
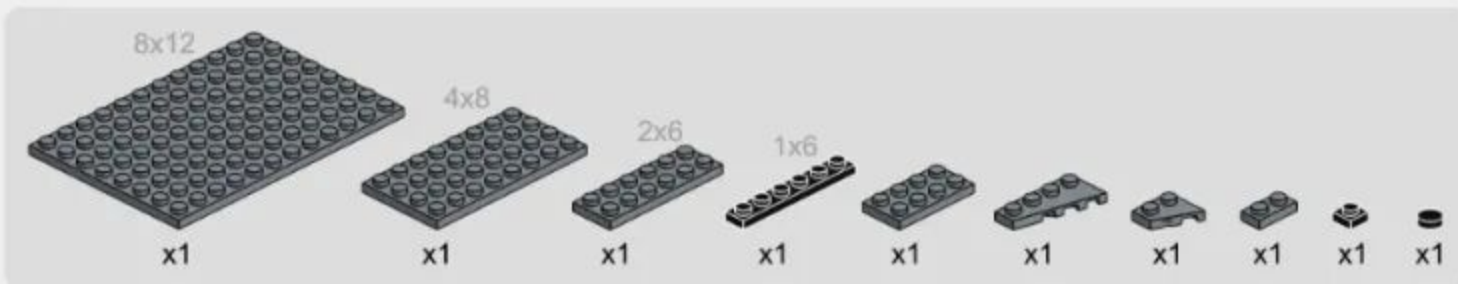

2-17

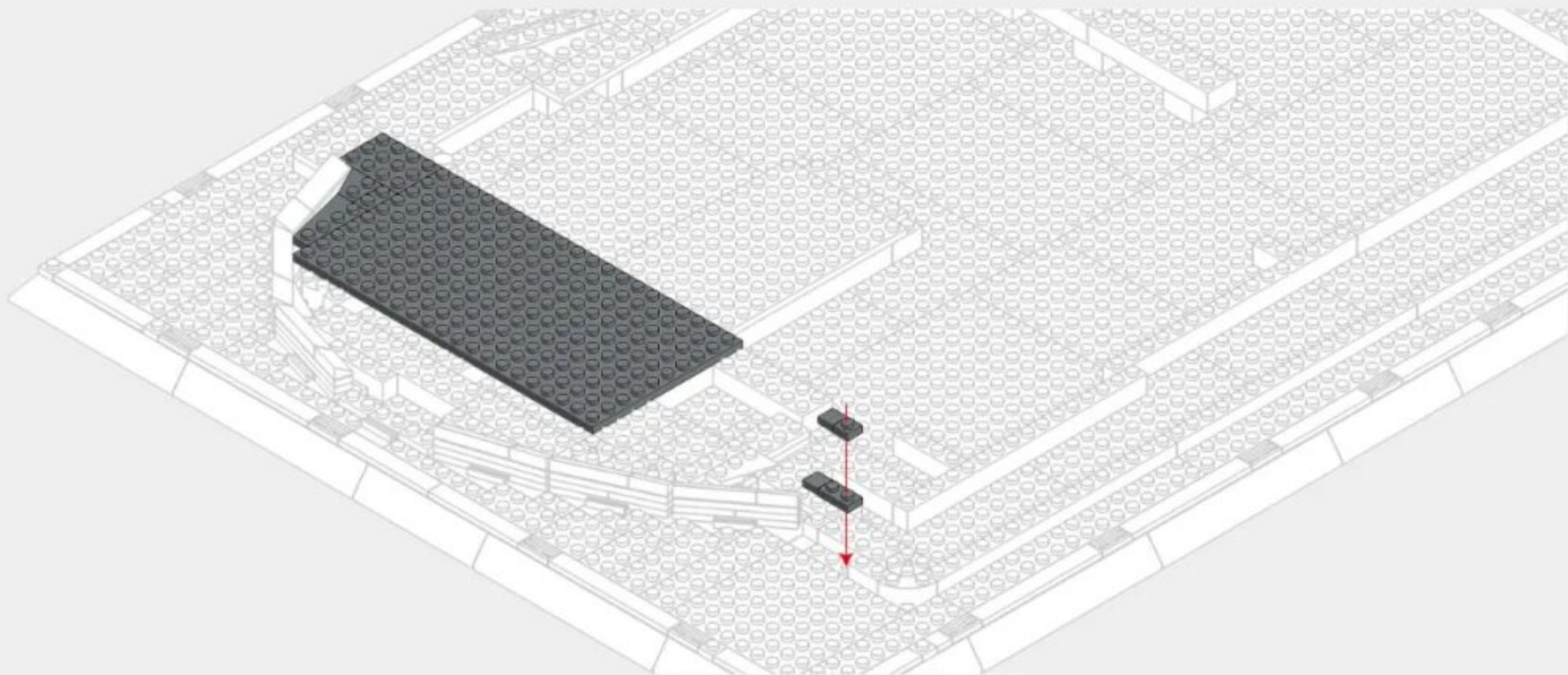
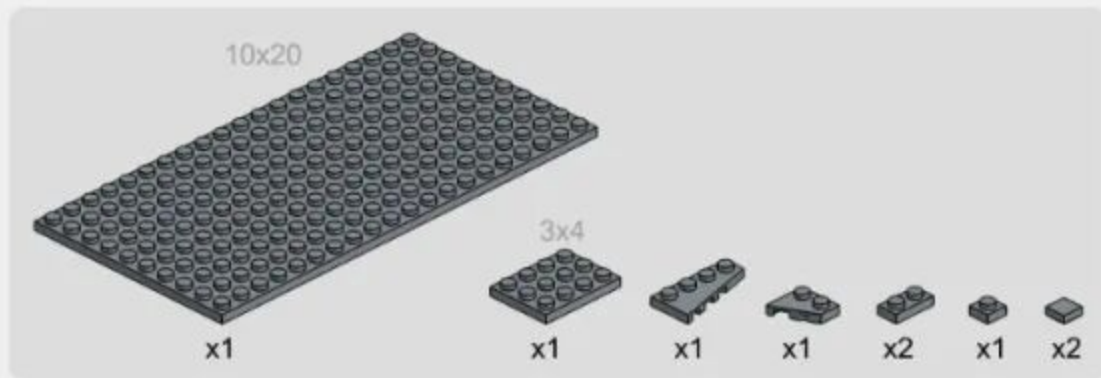

## 2-18

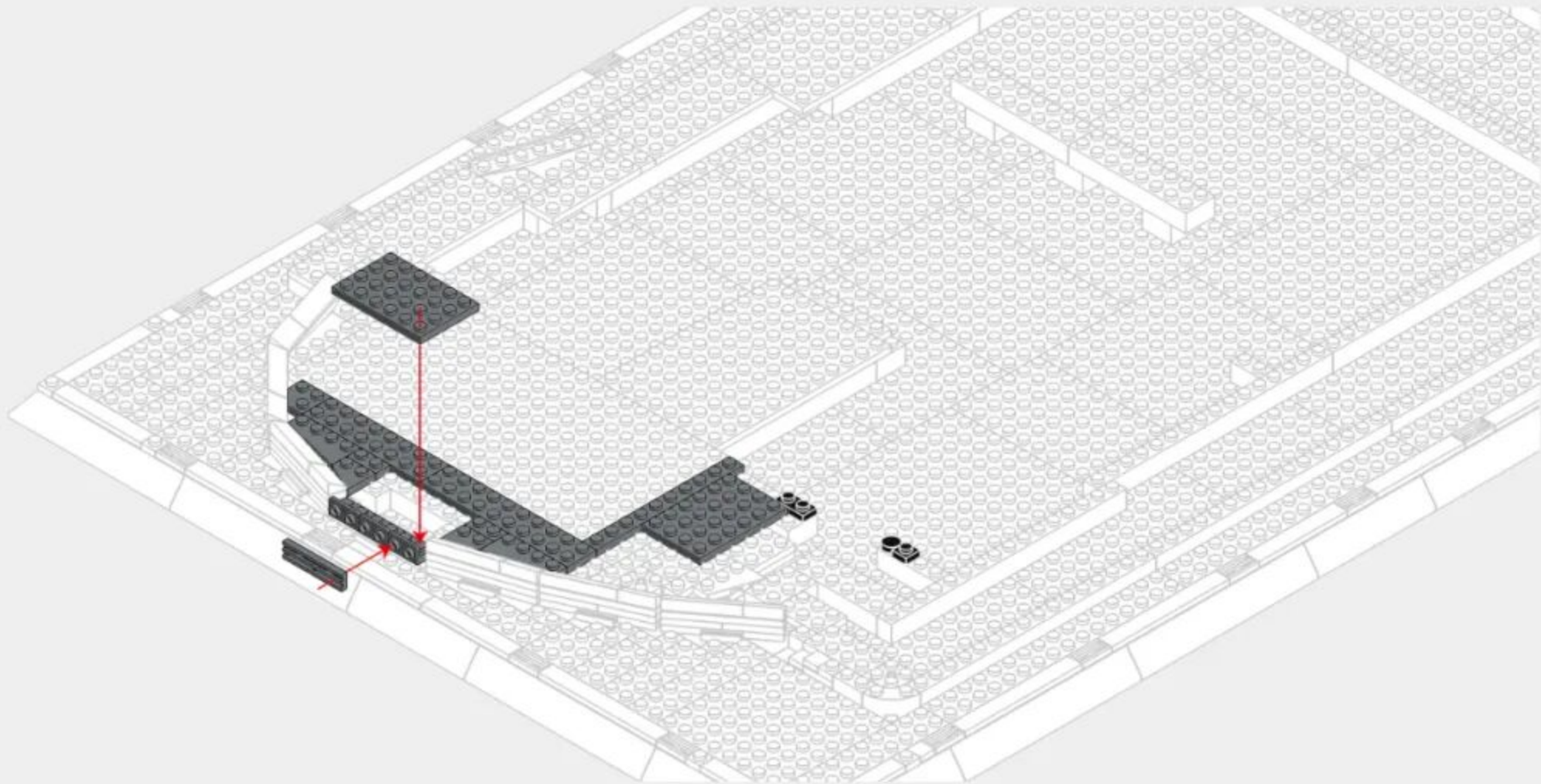
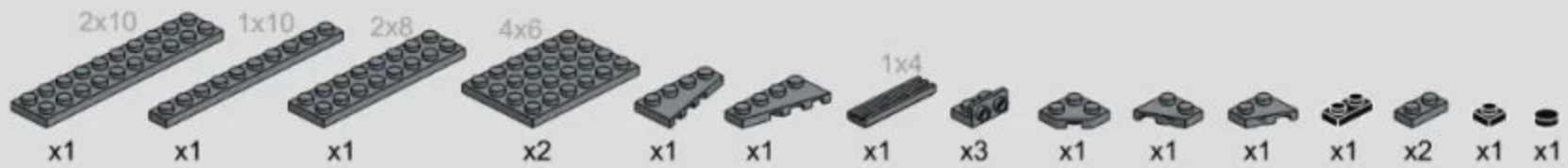

2-19

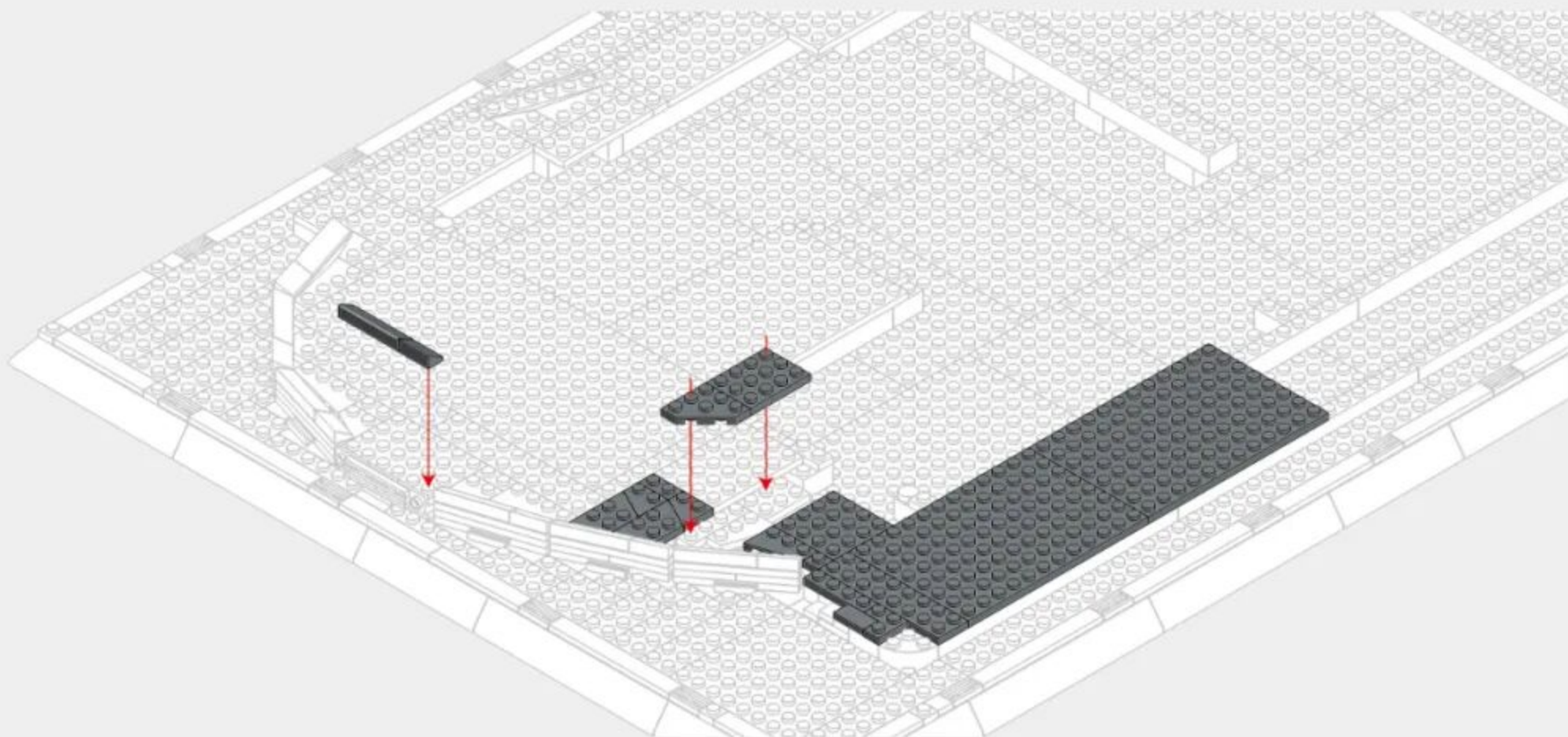
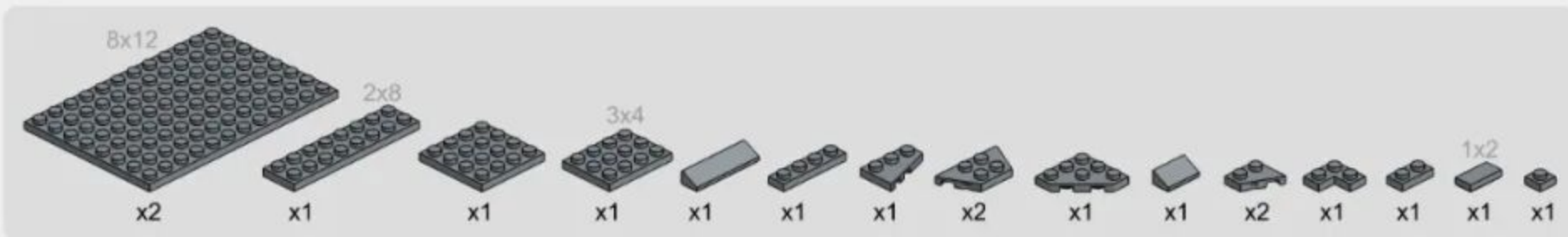

# 2-20

- 1x8 x2
- 1x6 x1
- 1x6 x5
- 2x4 x1
- Grey Technic Brick x1
- 1x6 with 4 holes x1
- 1x6 with 3 holes x2
- 1x6 with 2 holes x2
- 1x6 with 1 hole x1
- 1x3 x8
- 2x2 x2
- 1x2 with 2 holes x3
- Black Technic Brick x2
- 1x2 with 1 hole x4
- Black Technic Brick x2
- 1x2 x7
- 1x2 with 2 holes x2

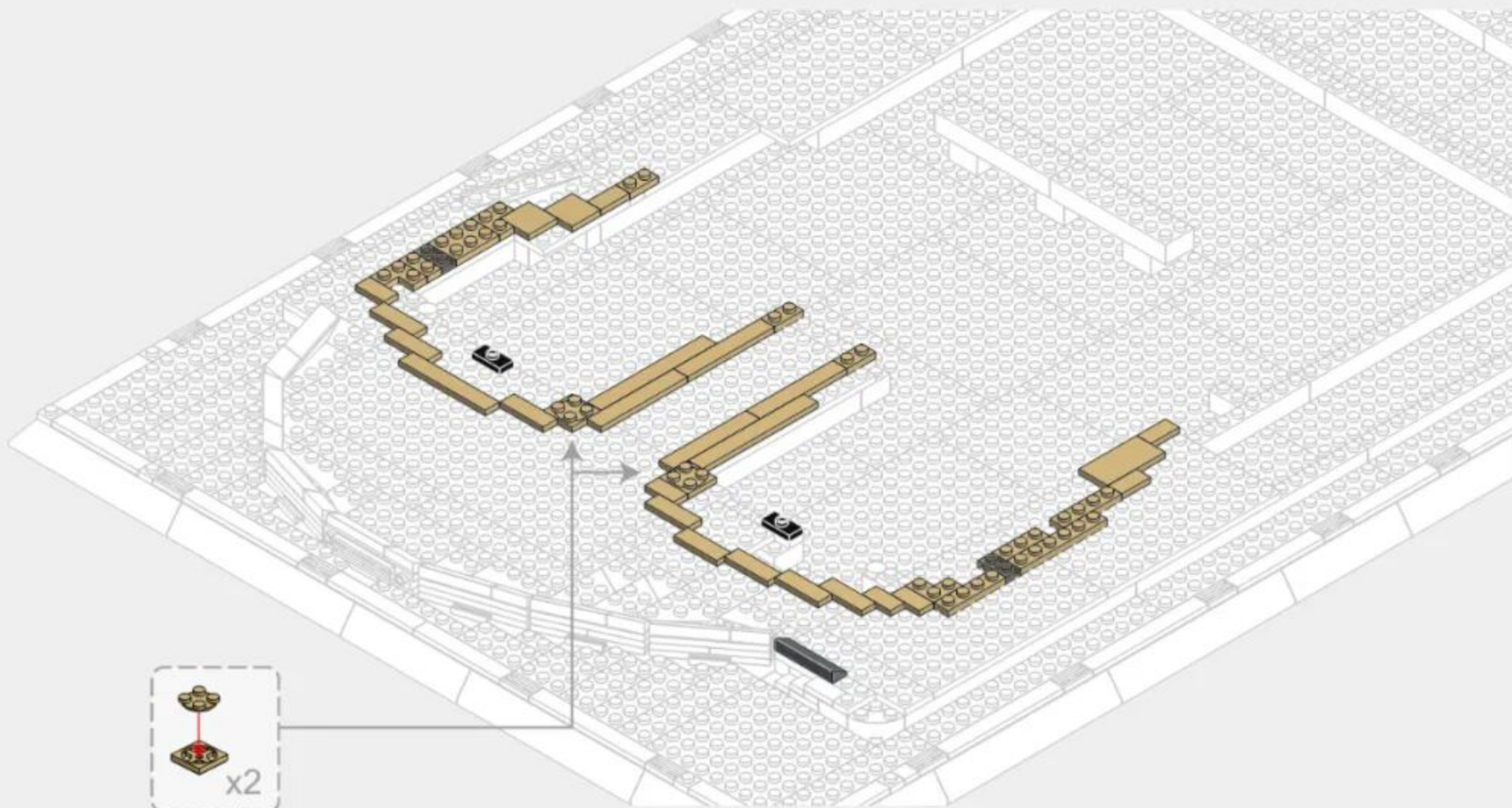

2-21

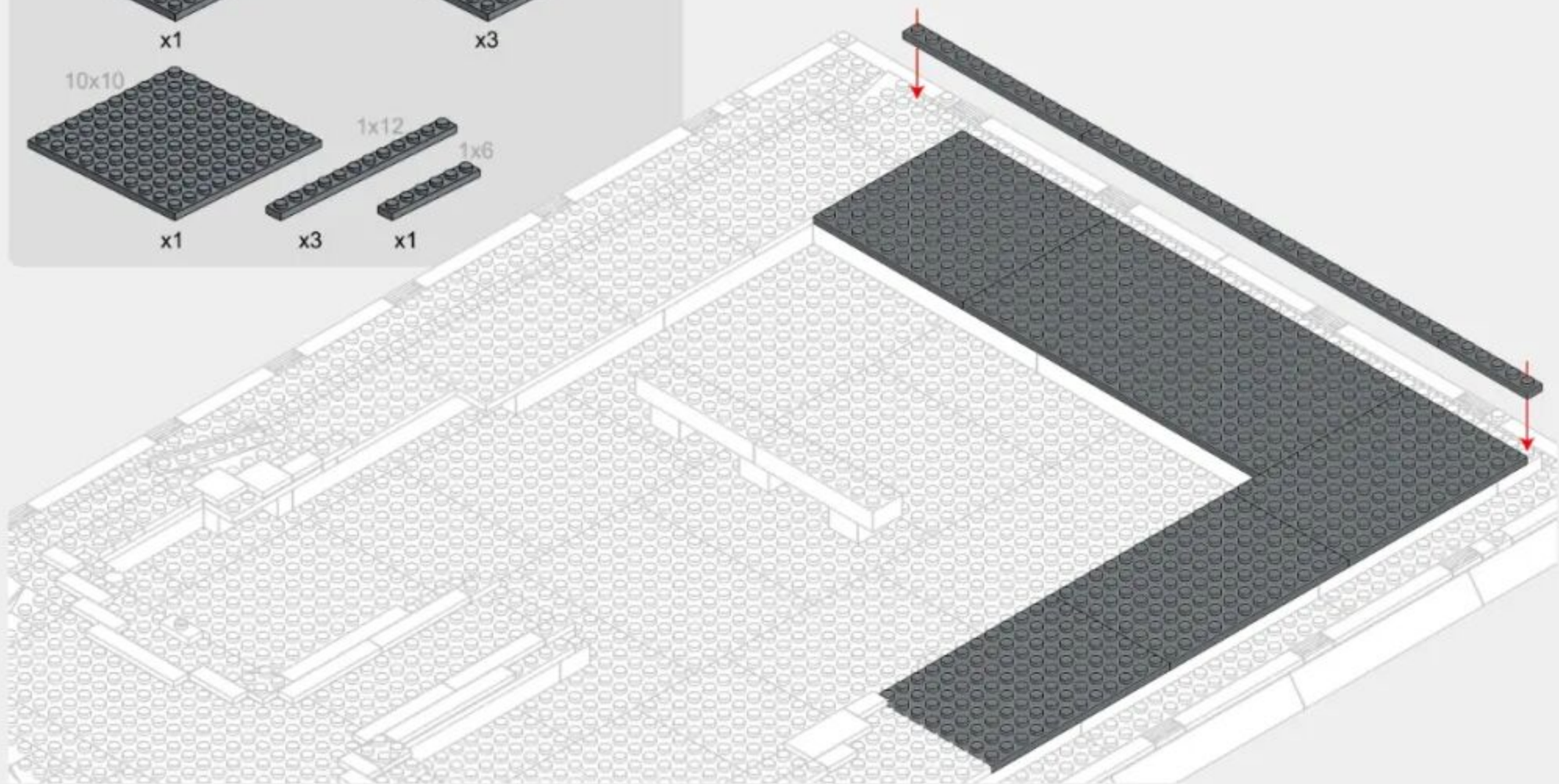
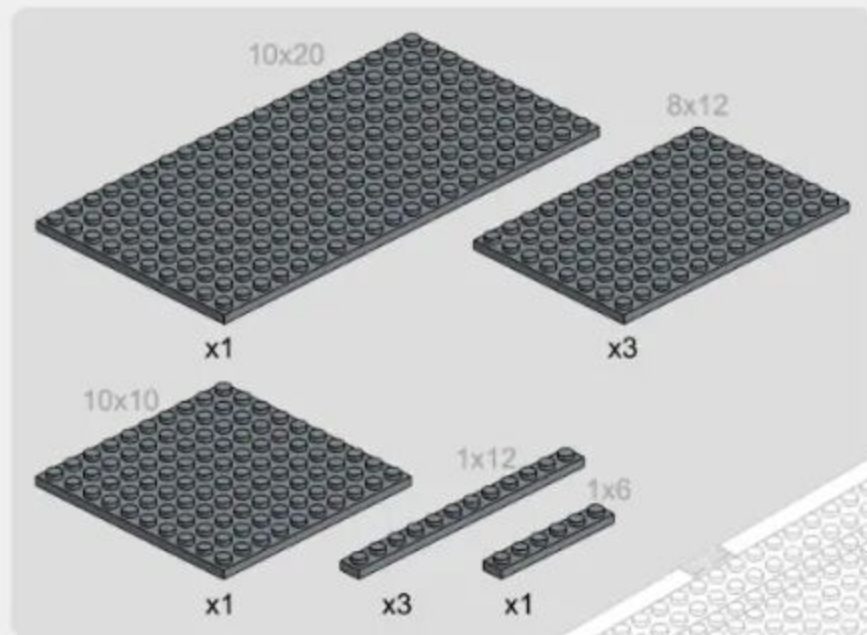



286PCS

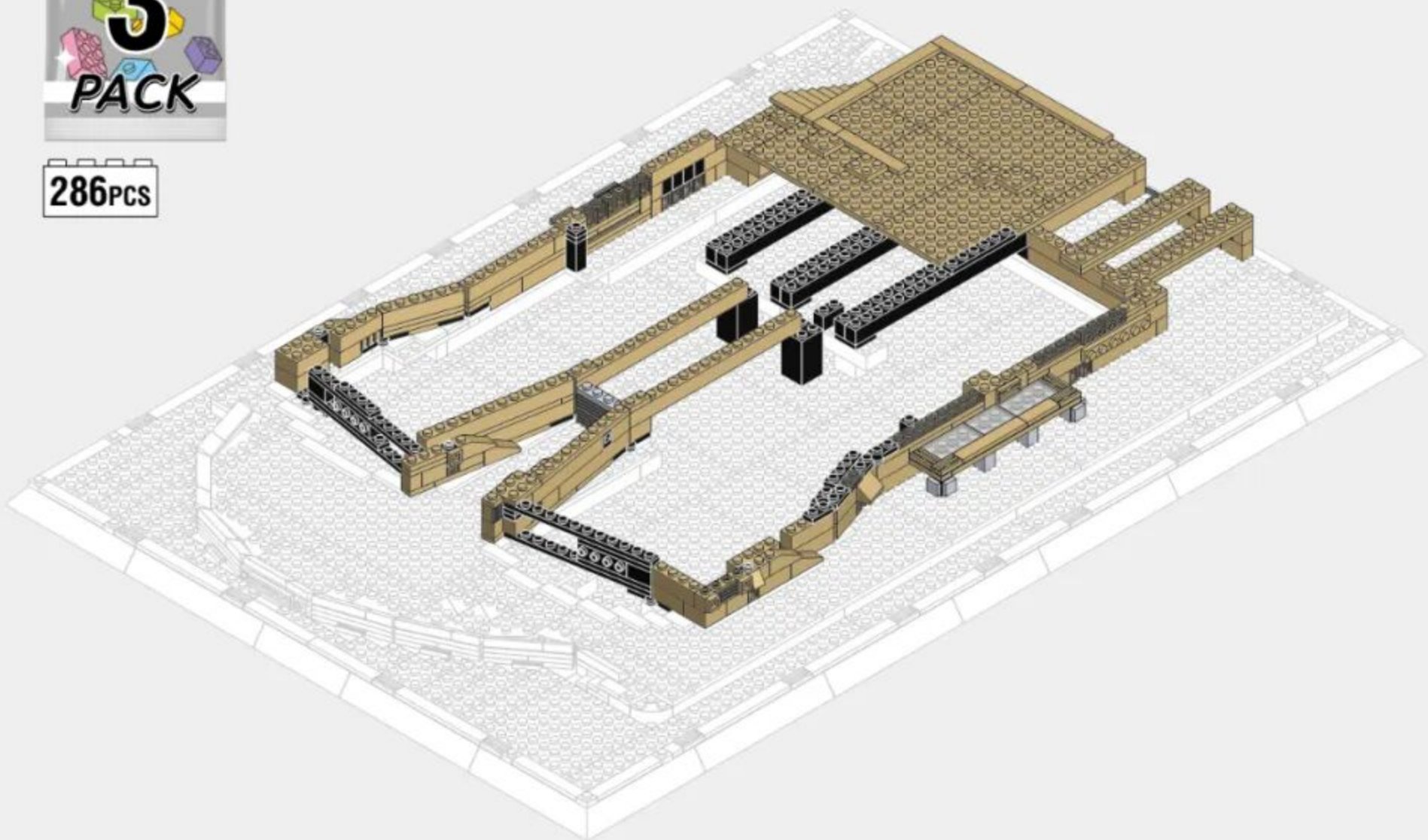

62

3-1

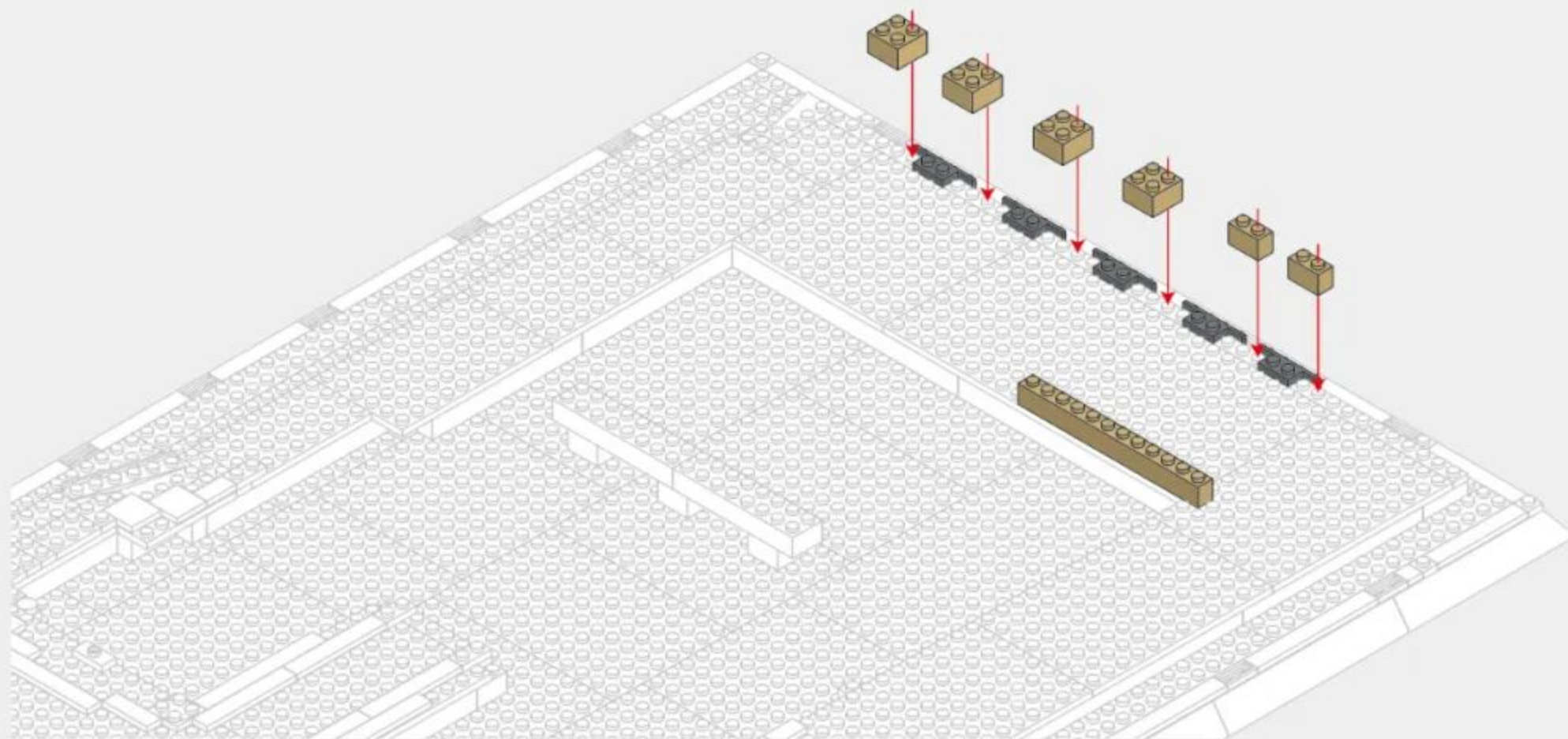
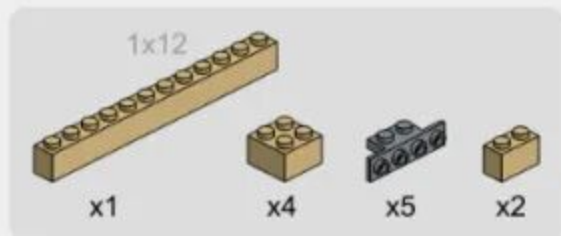

3-2

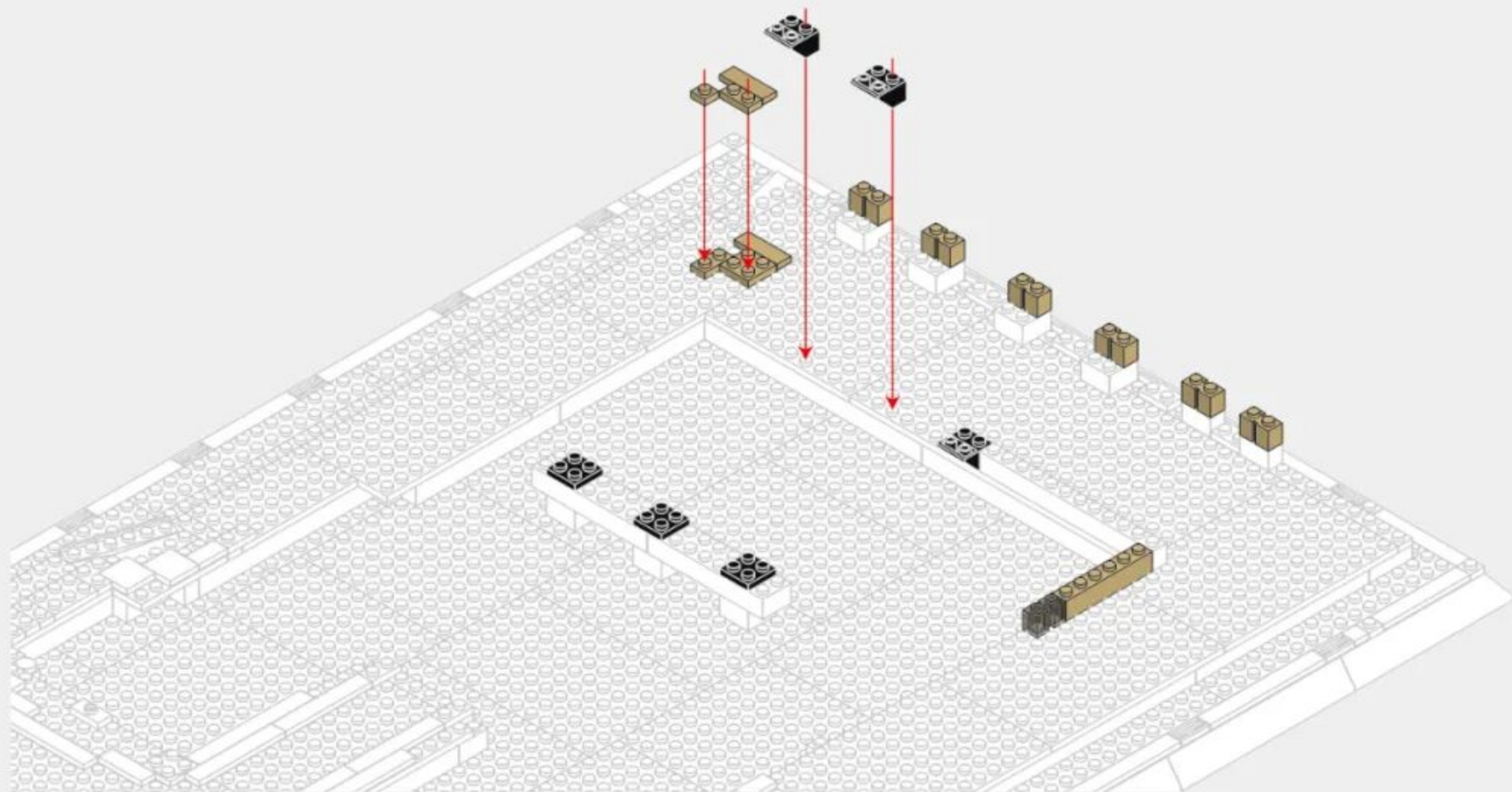

### 3-3

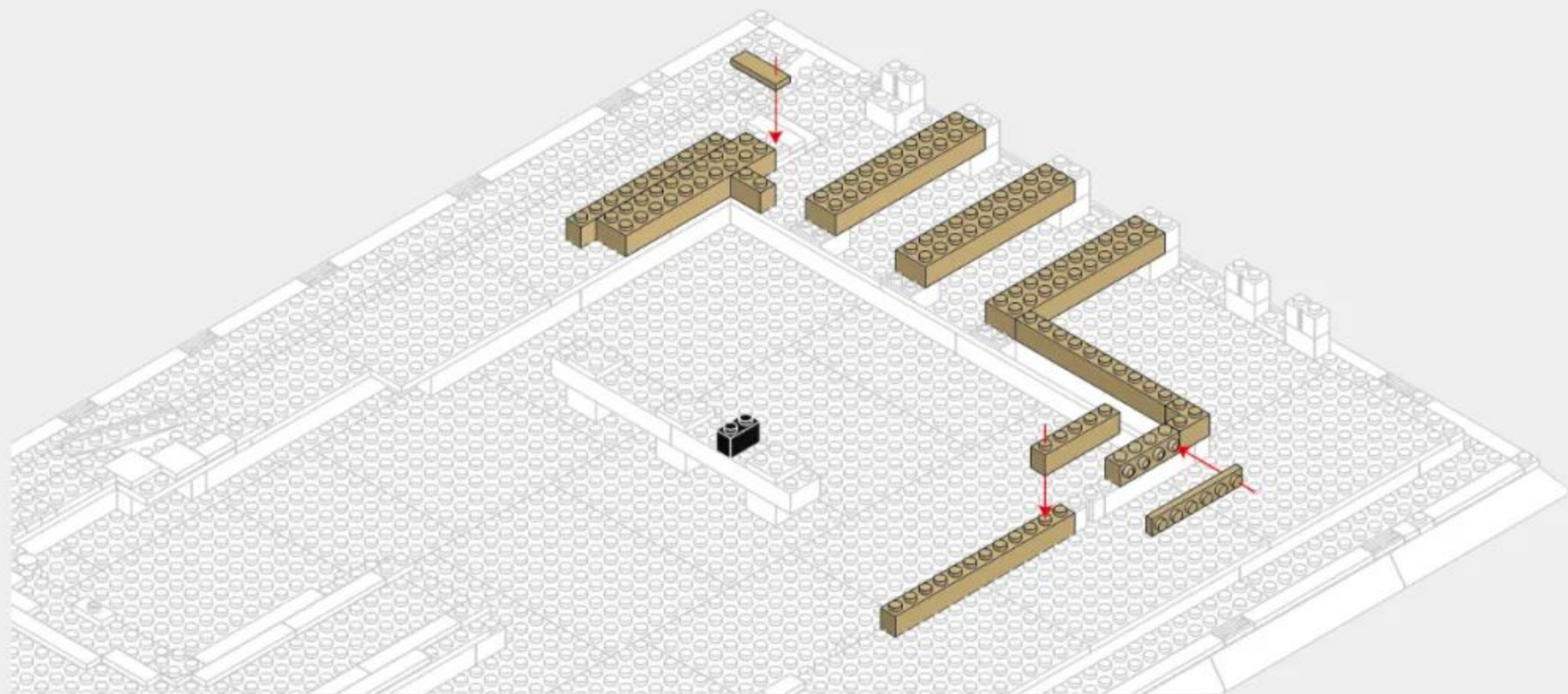
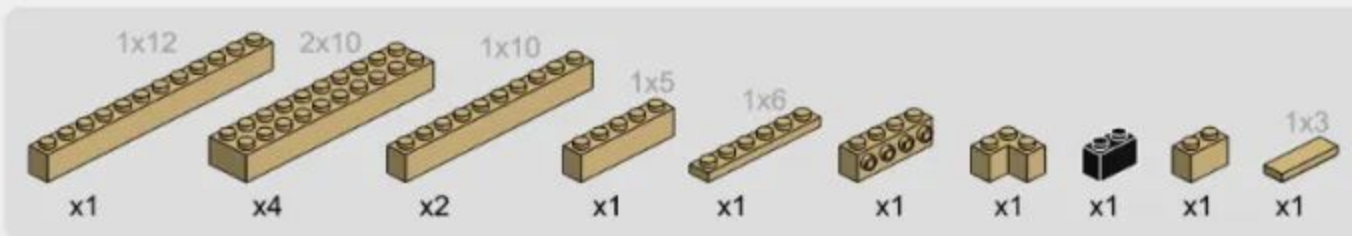

3-4

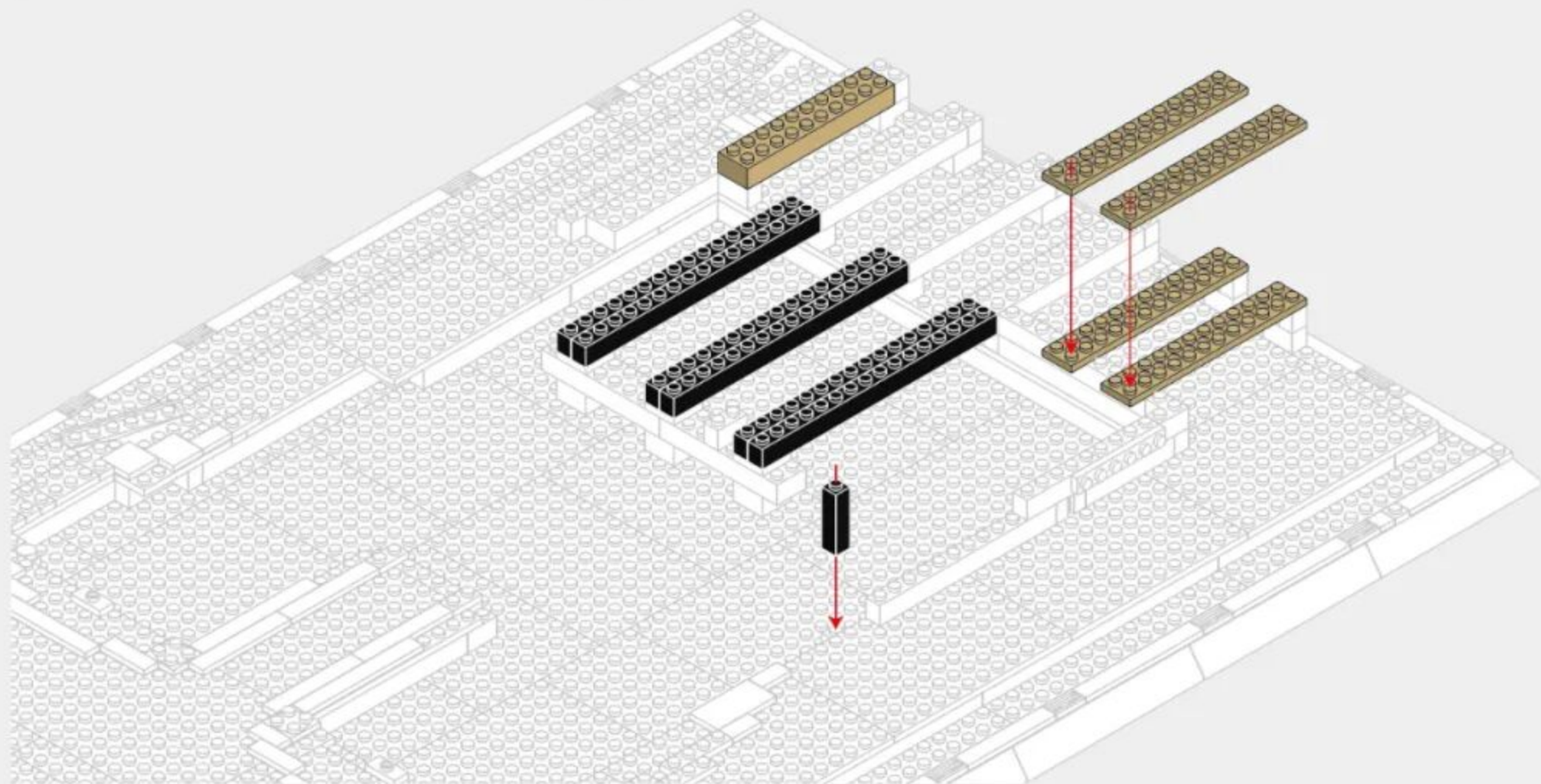
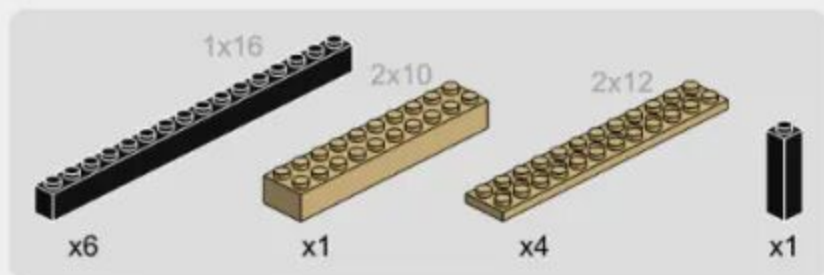

3-5

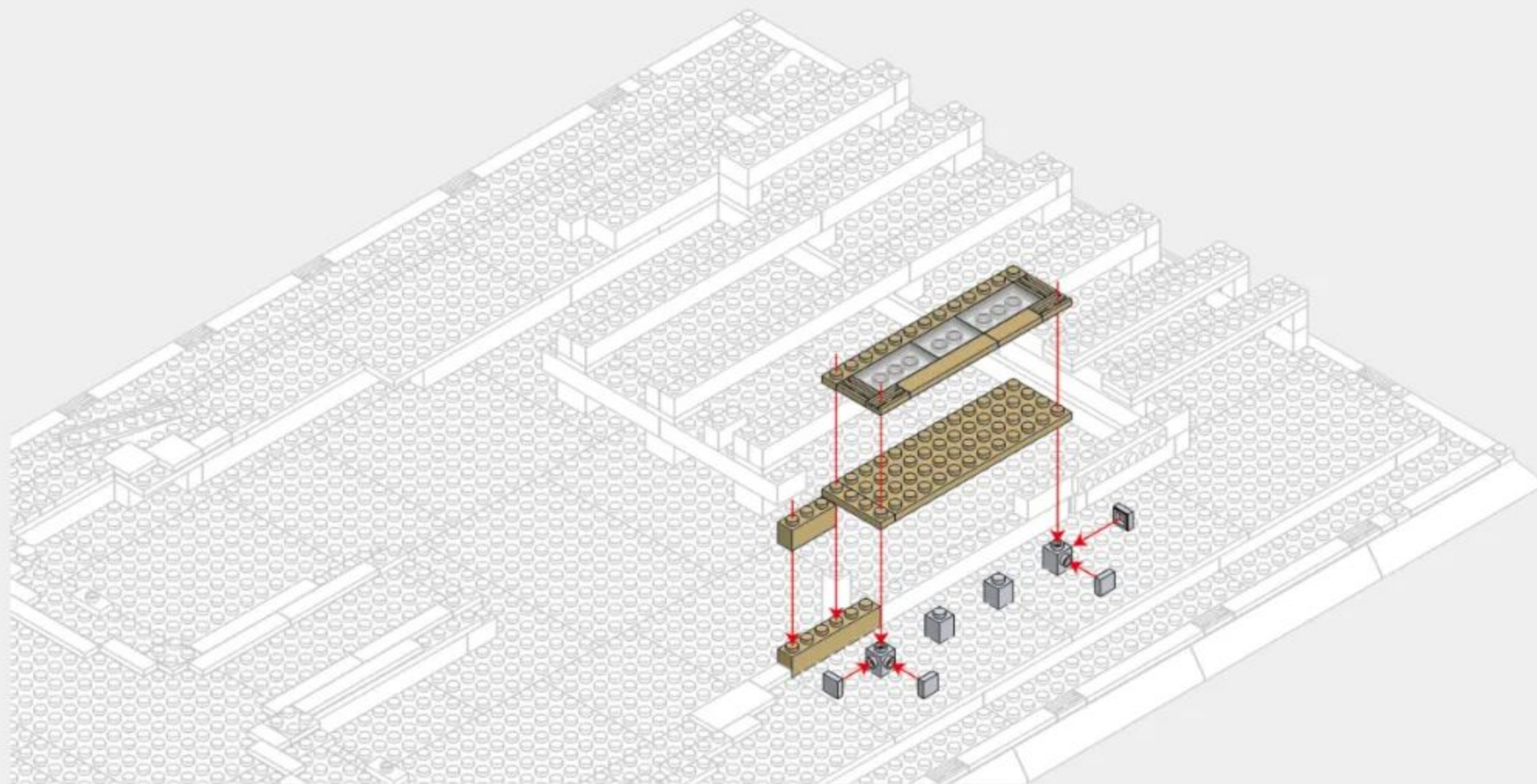
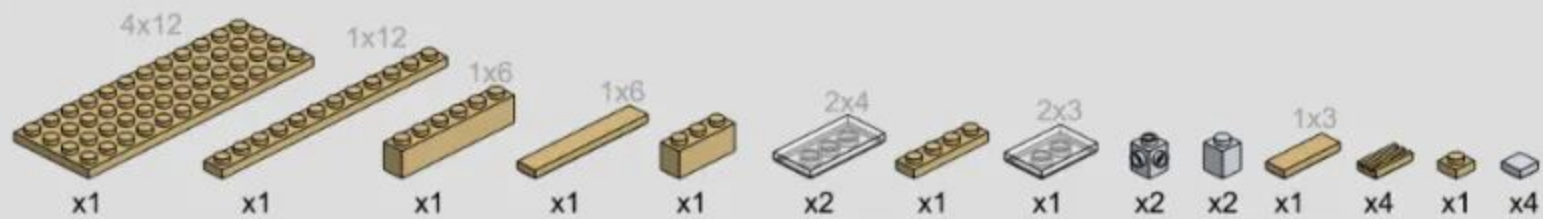

3-6

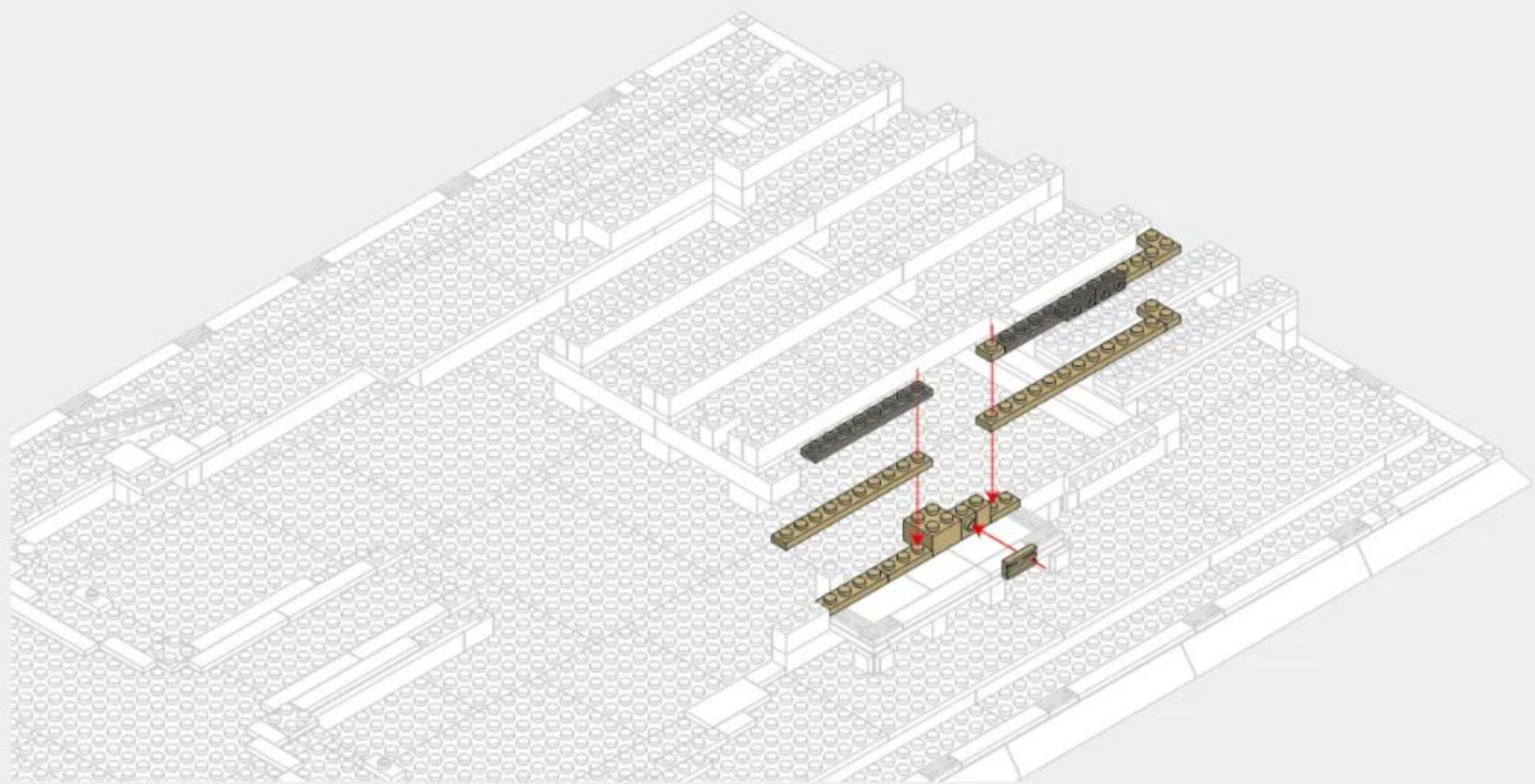
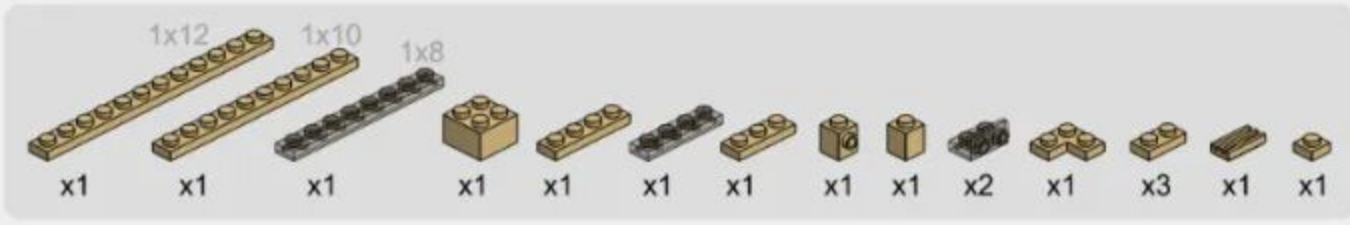

3-7

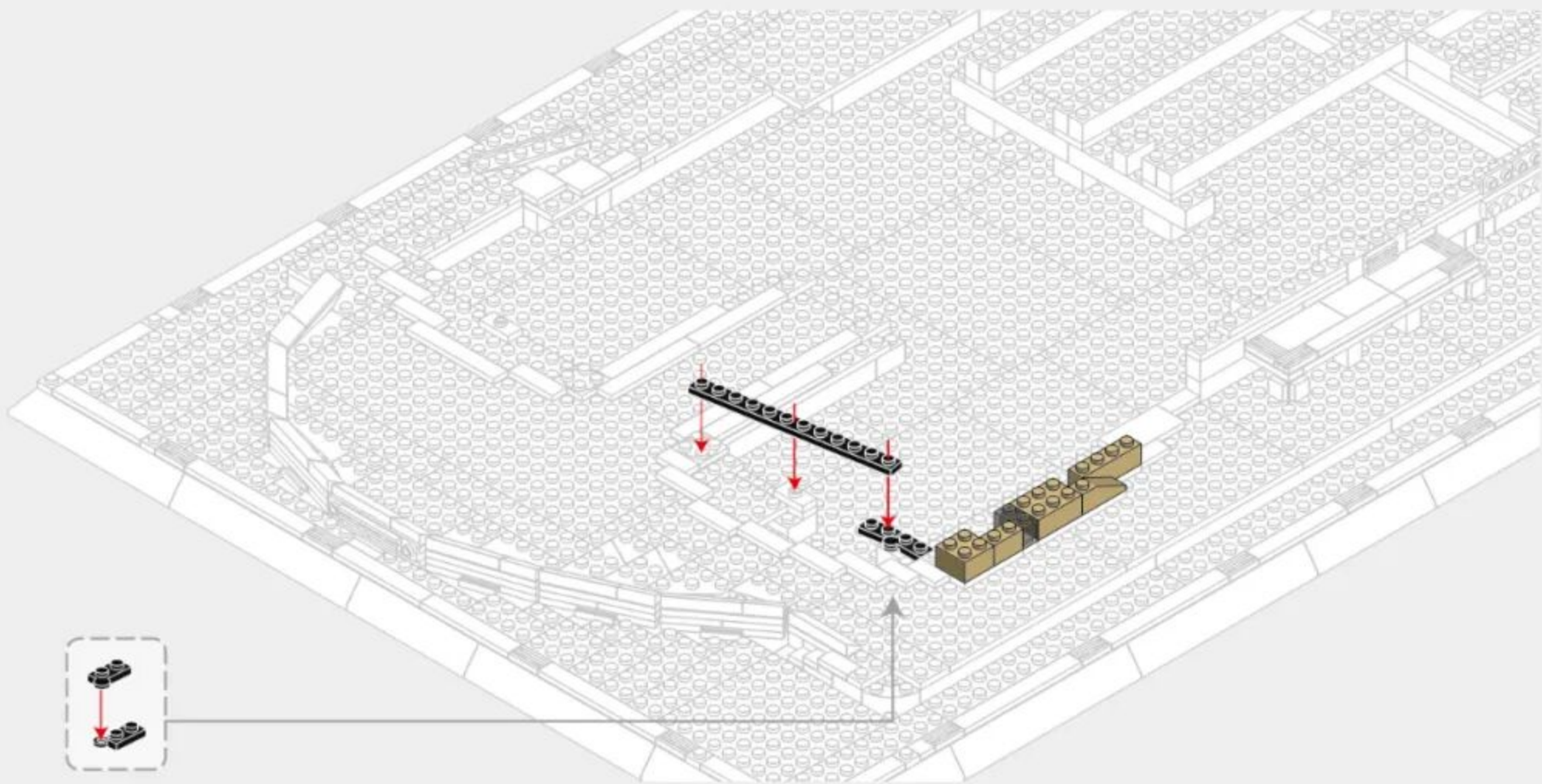
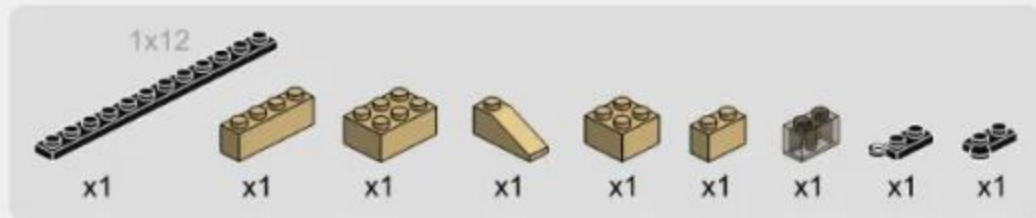

3-8

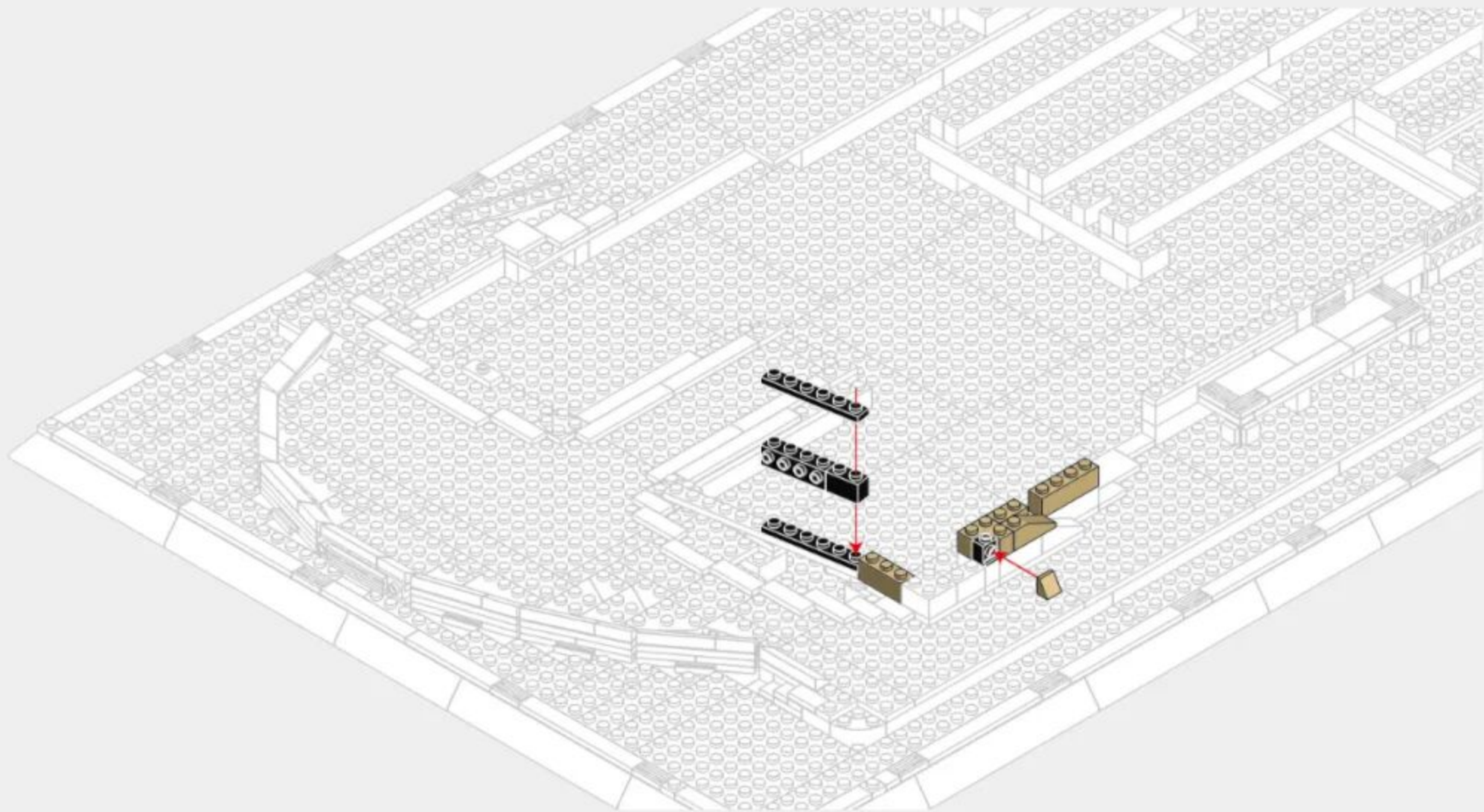



3-10

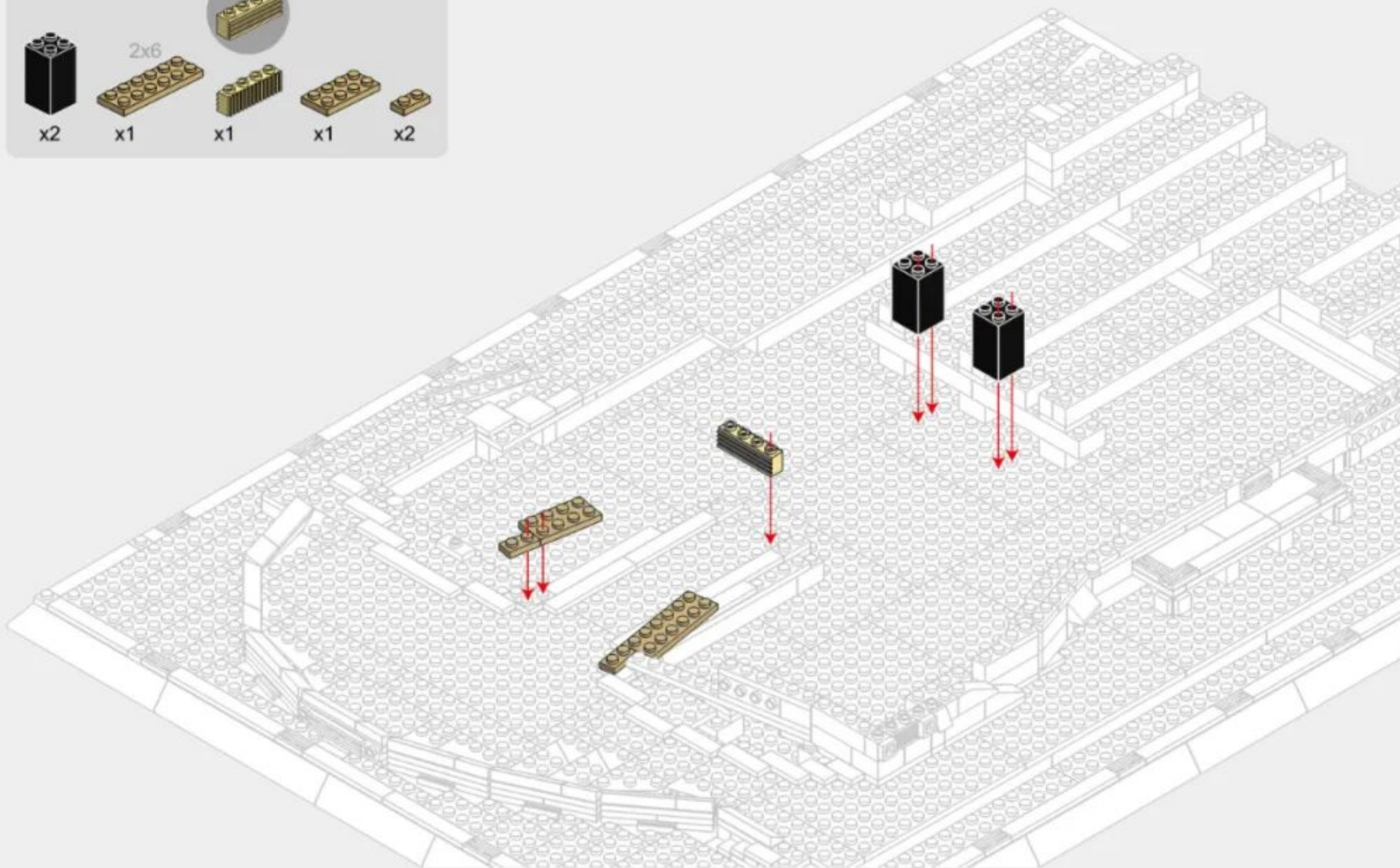
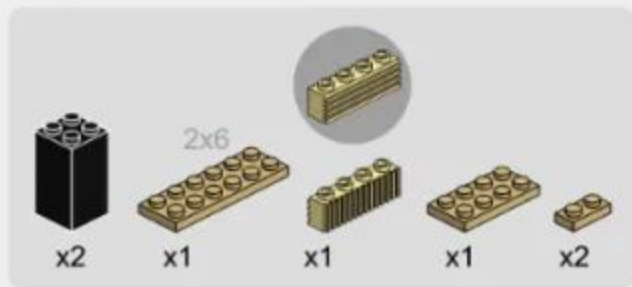

# 3-11

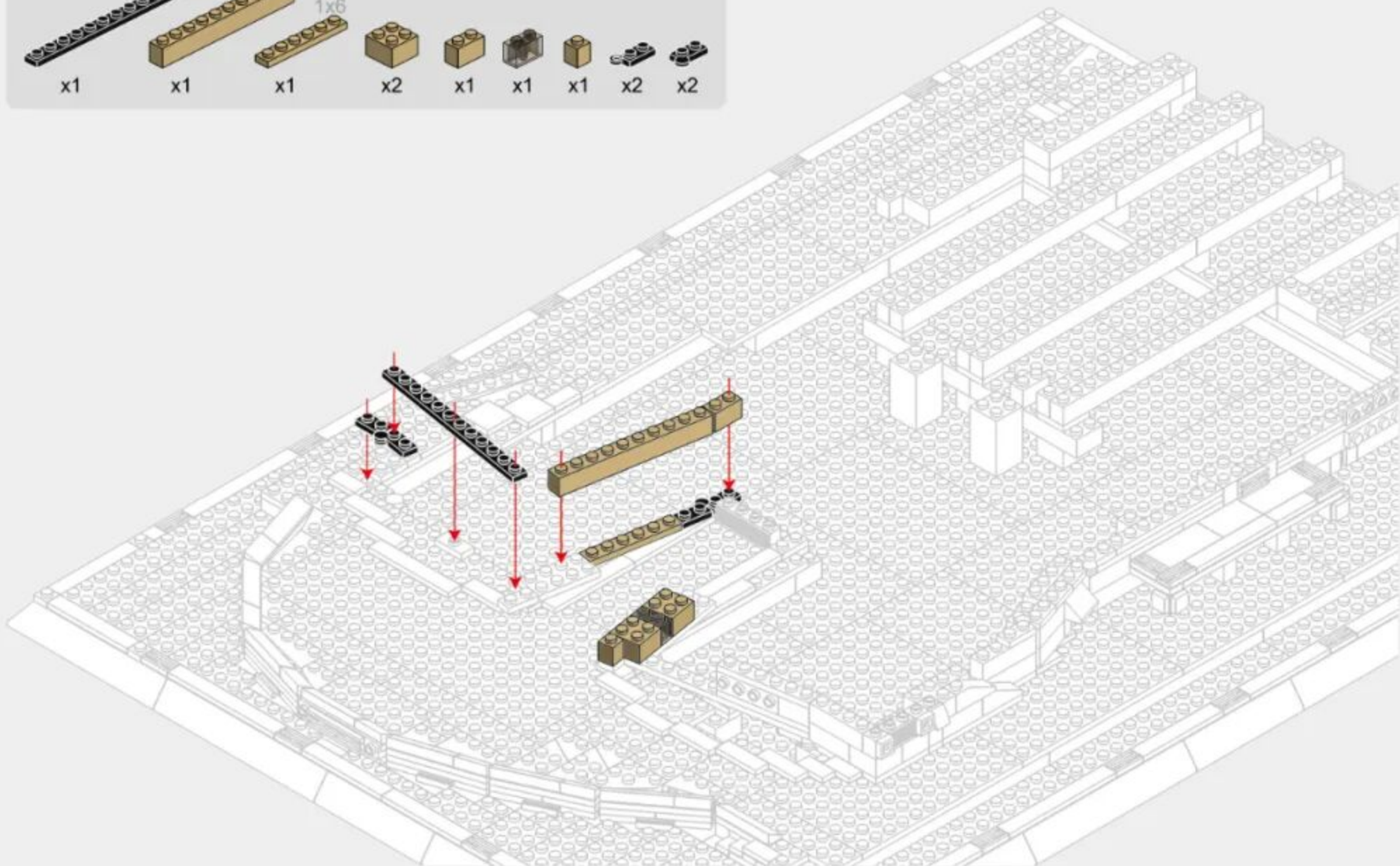
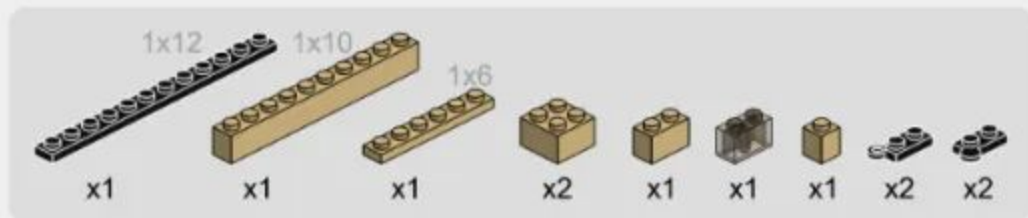

3-12

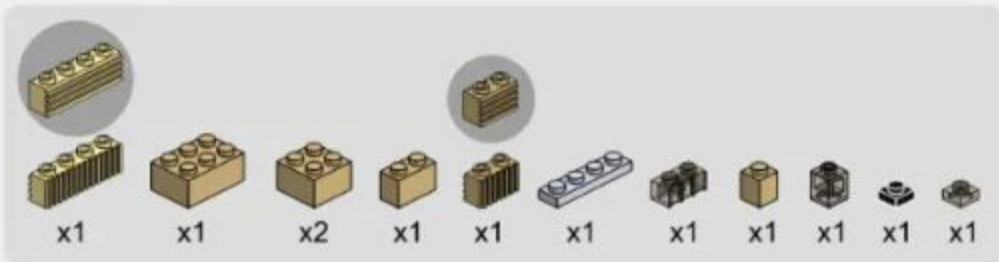

### 3-13

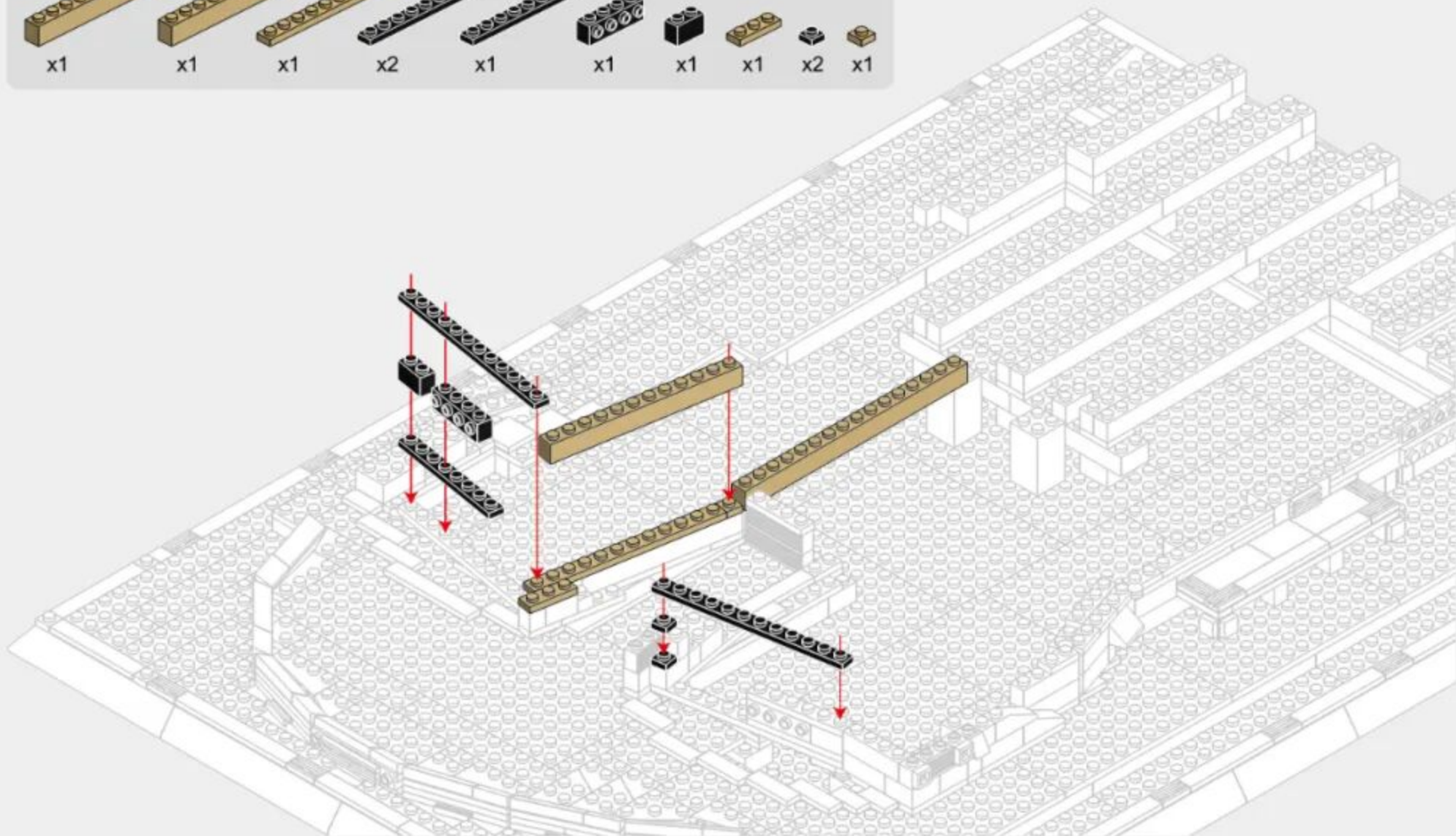
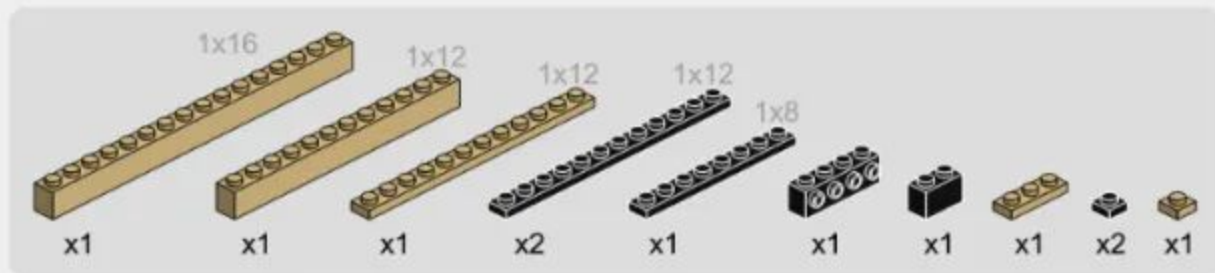

3-14

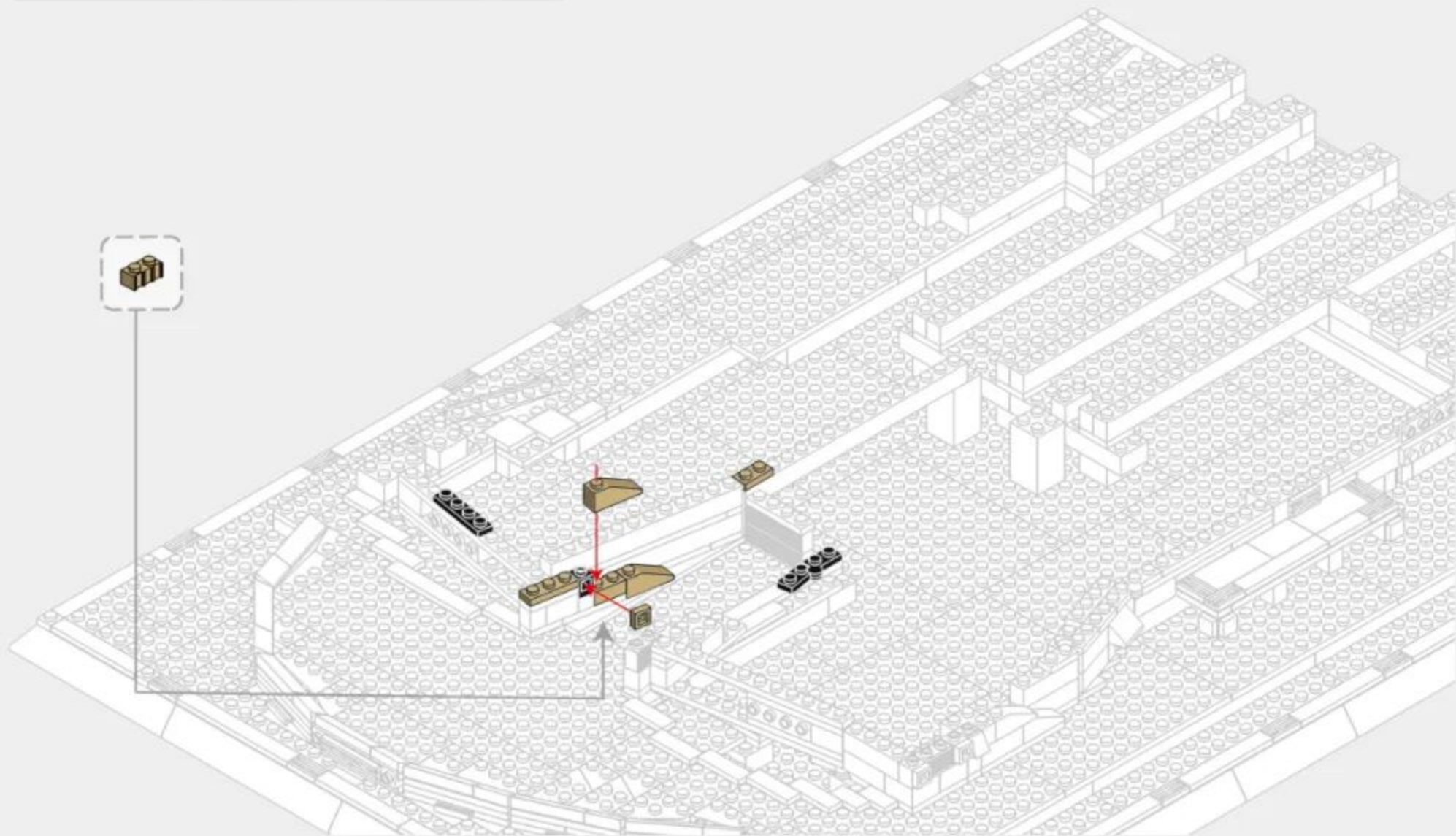

3-15

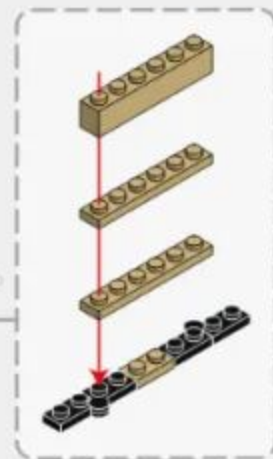
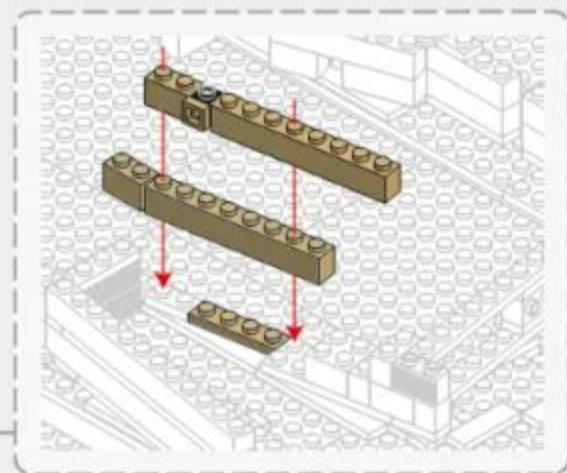
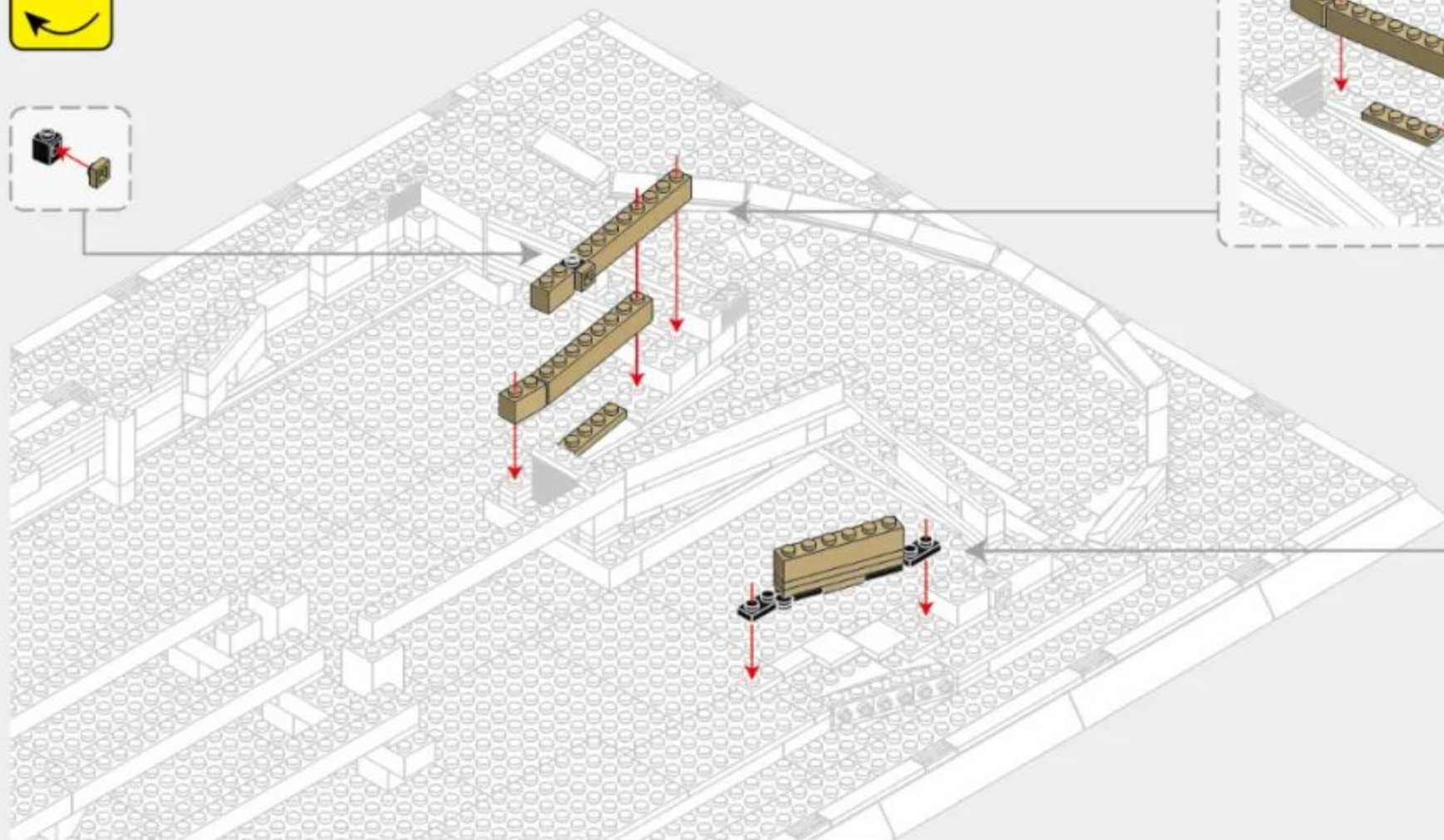
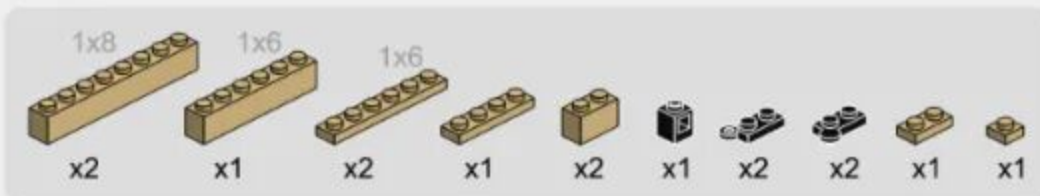

# 3-16

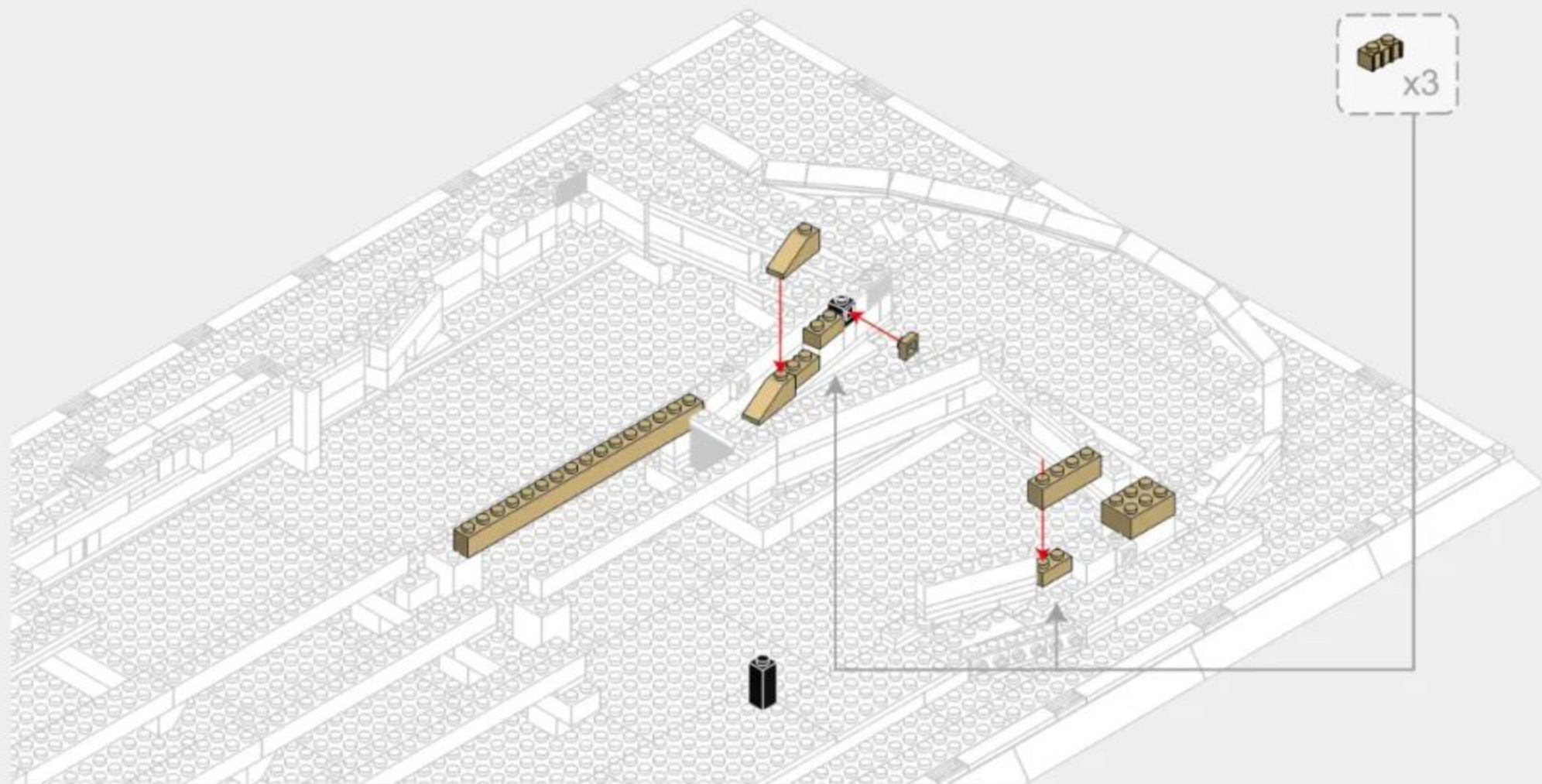
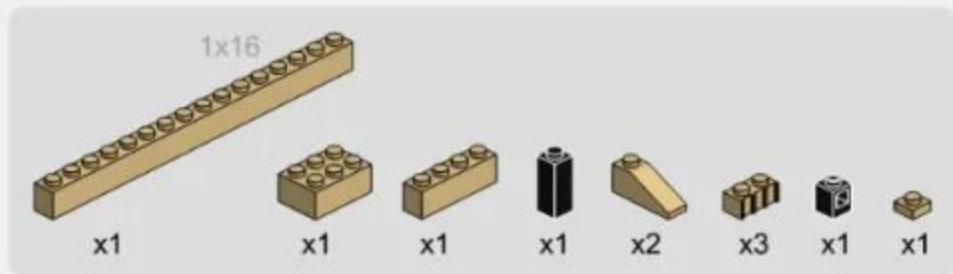

# 3-17

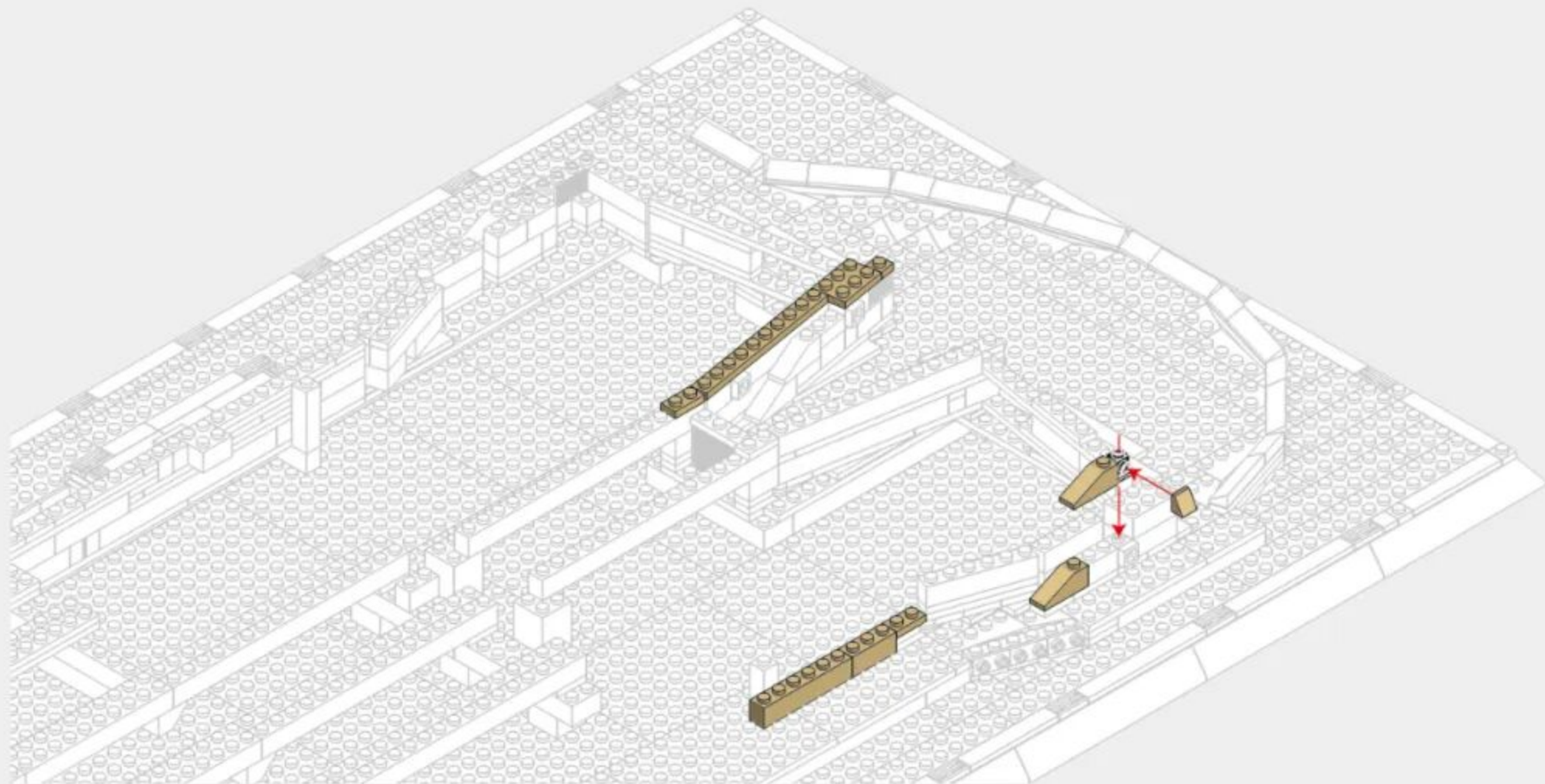

3-18

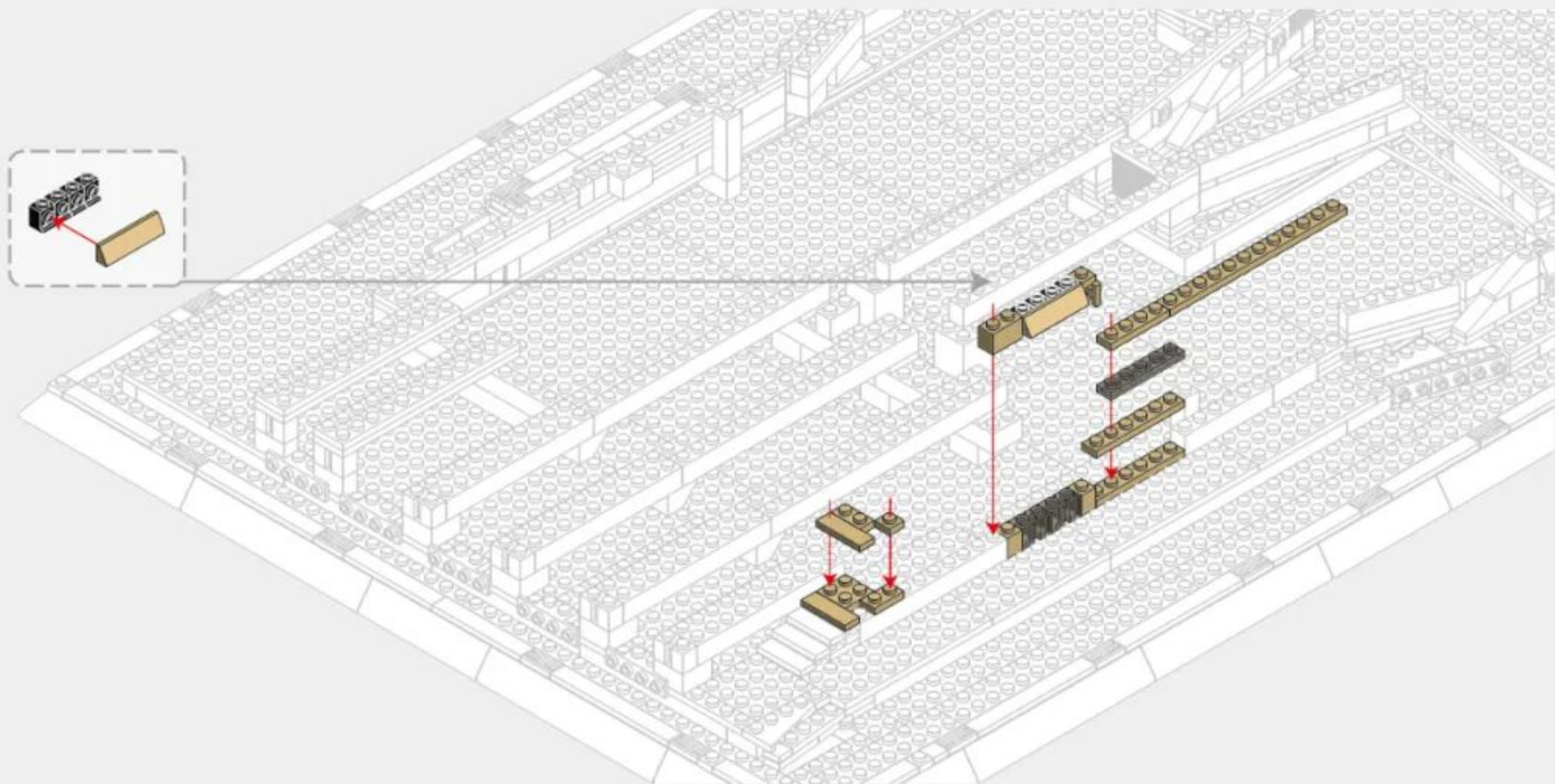

# 3-19

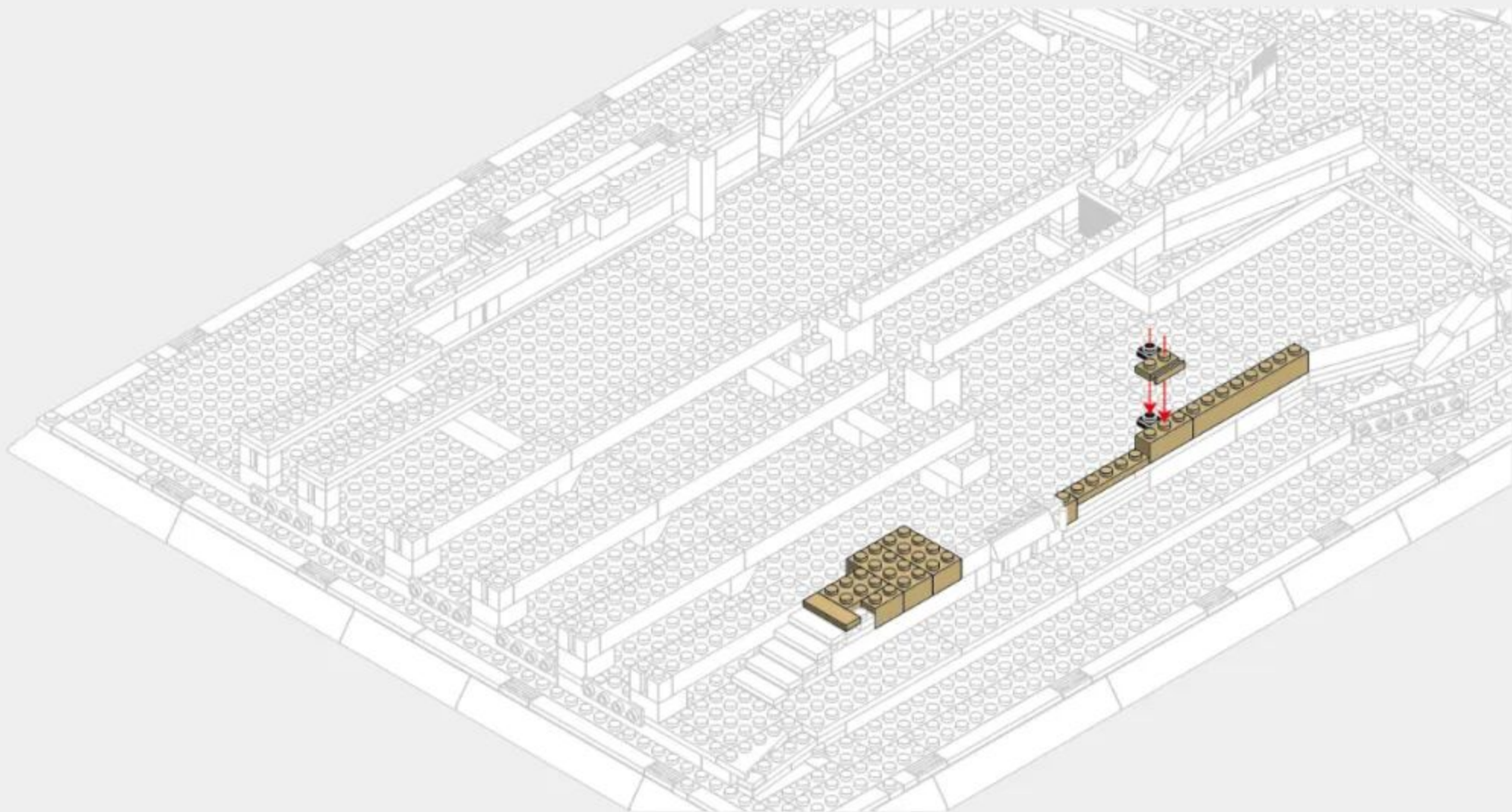
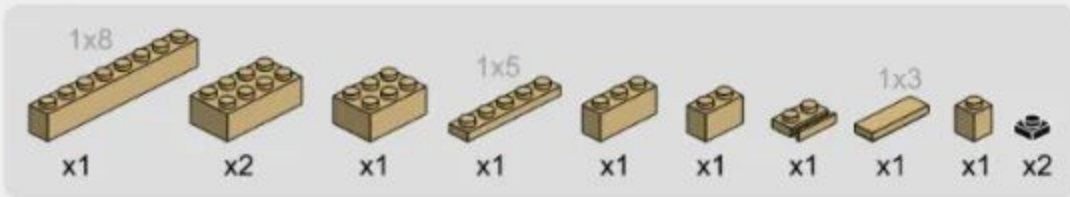

# 3-20

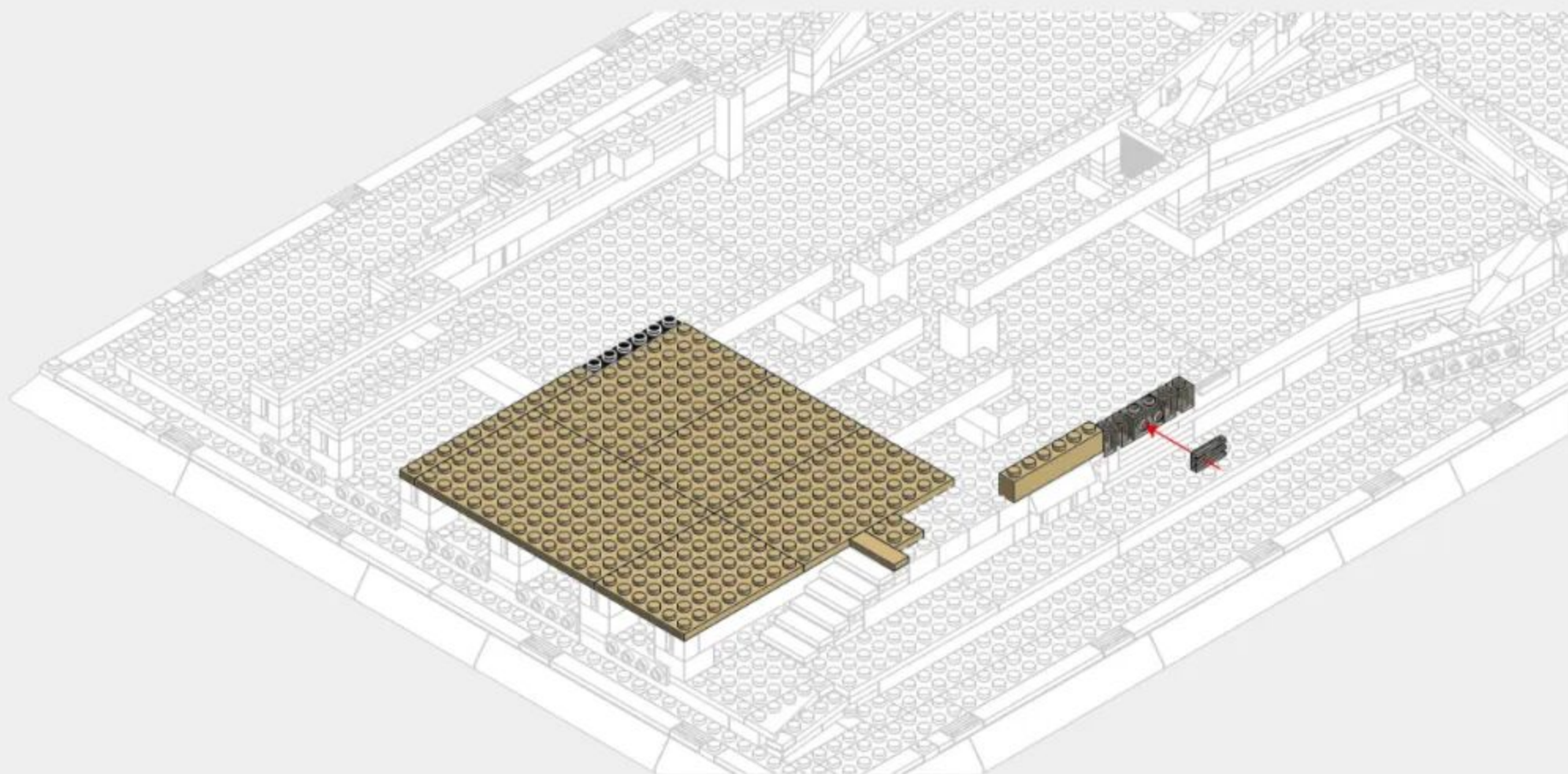
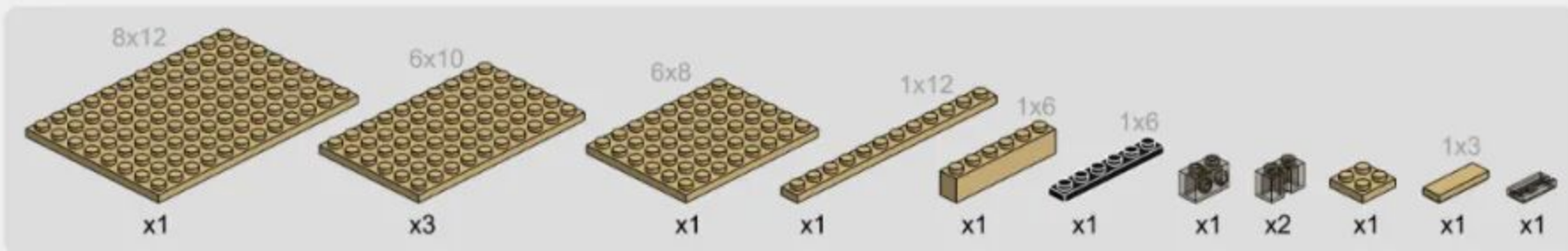

3-21

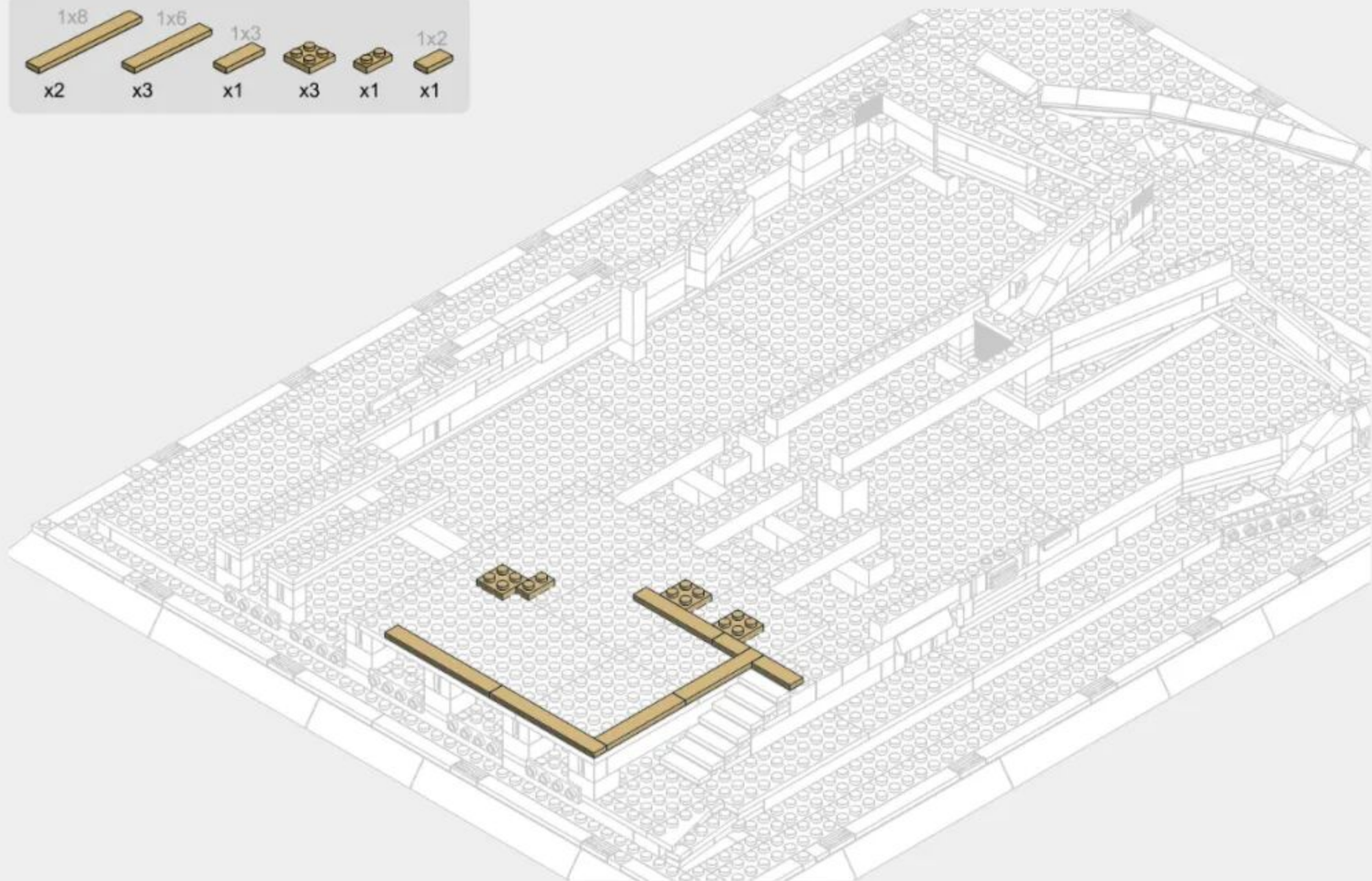
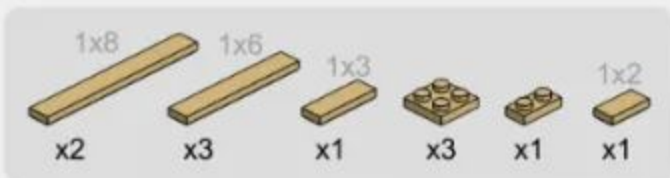



287 PCS

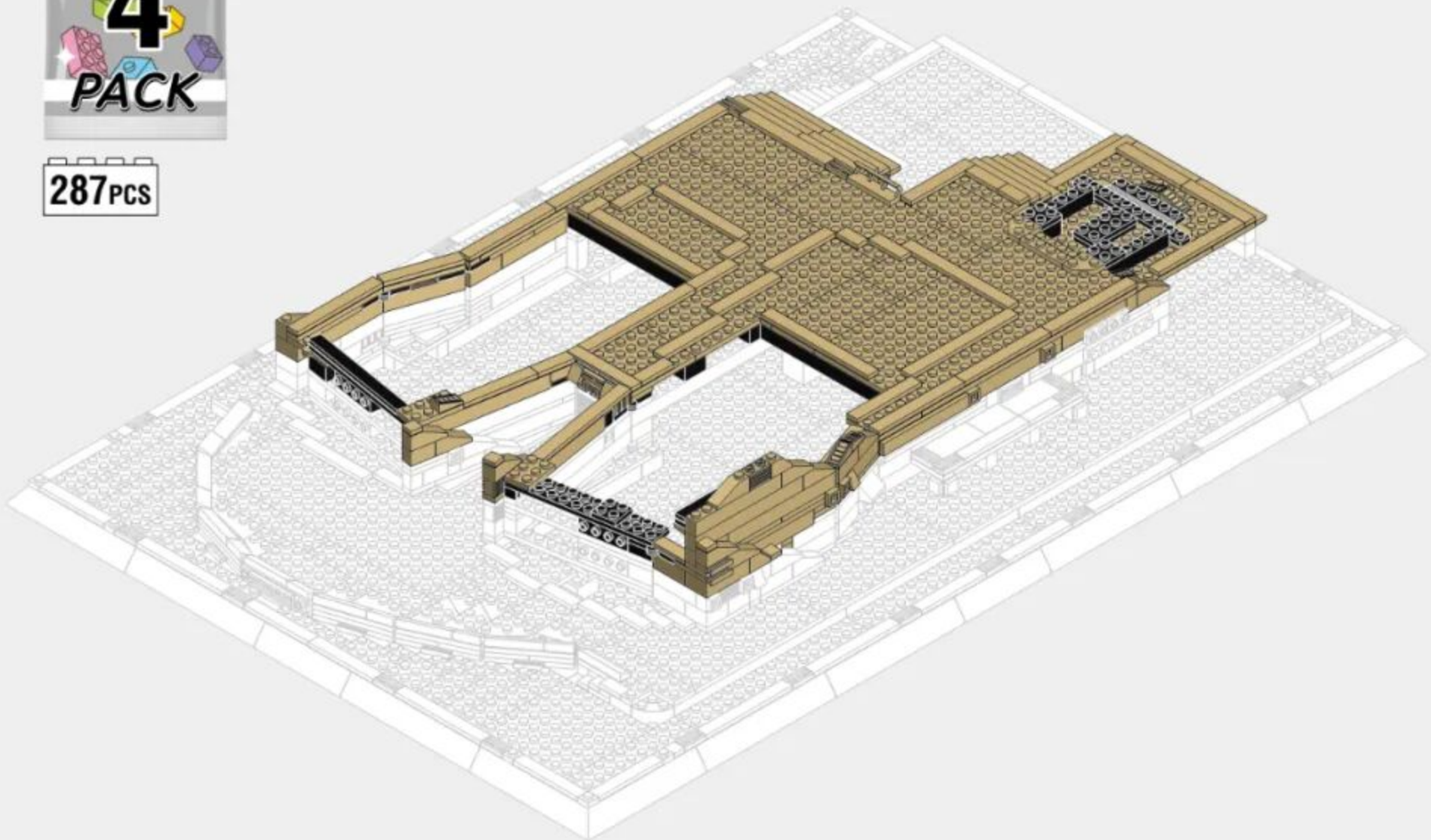

4-1

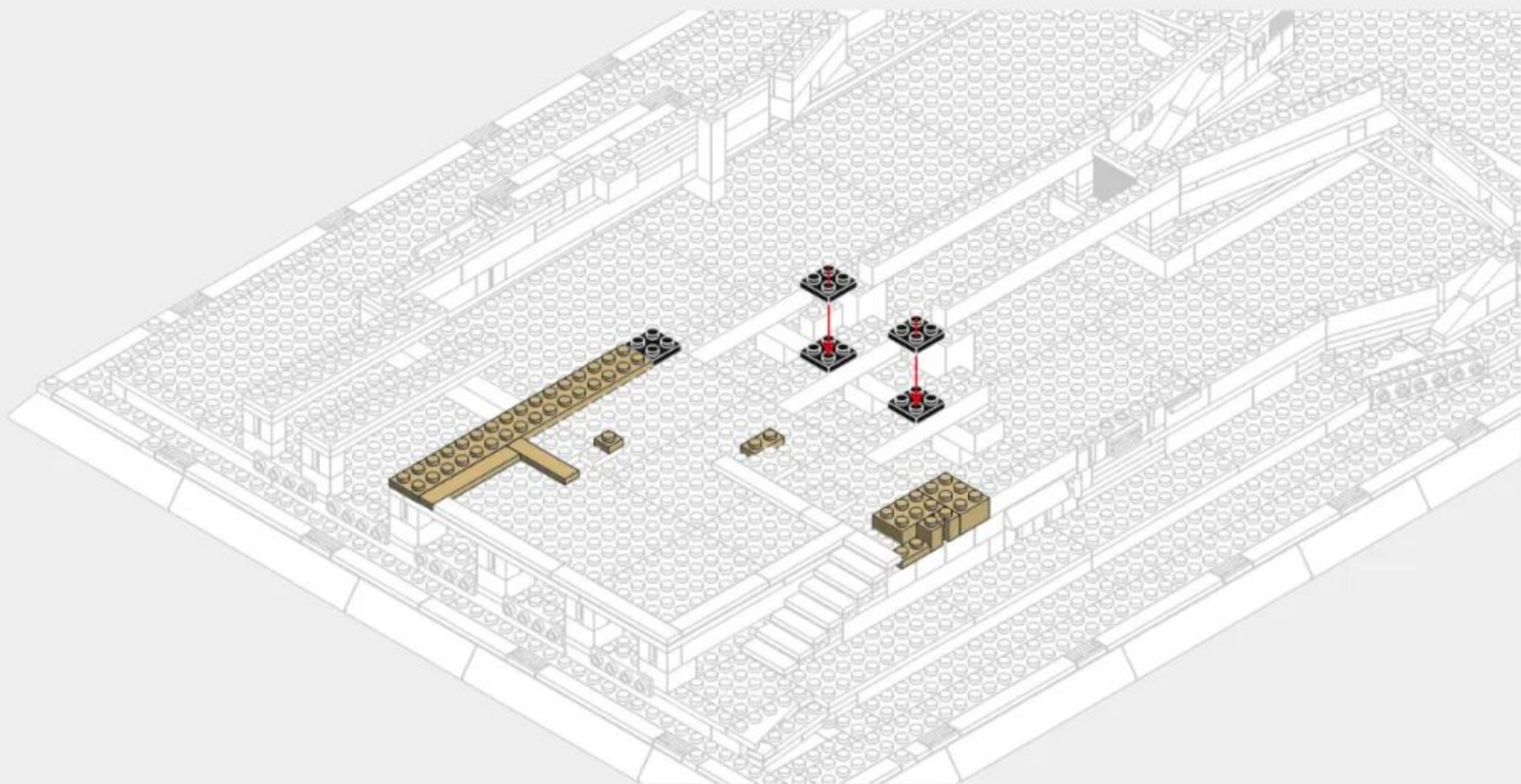
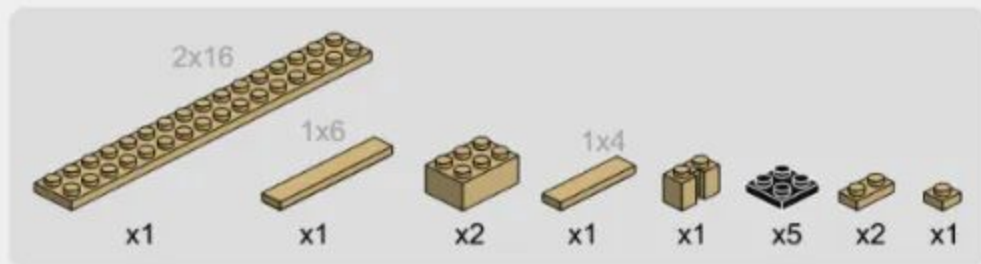

4-2

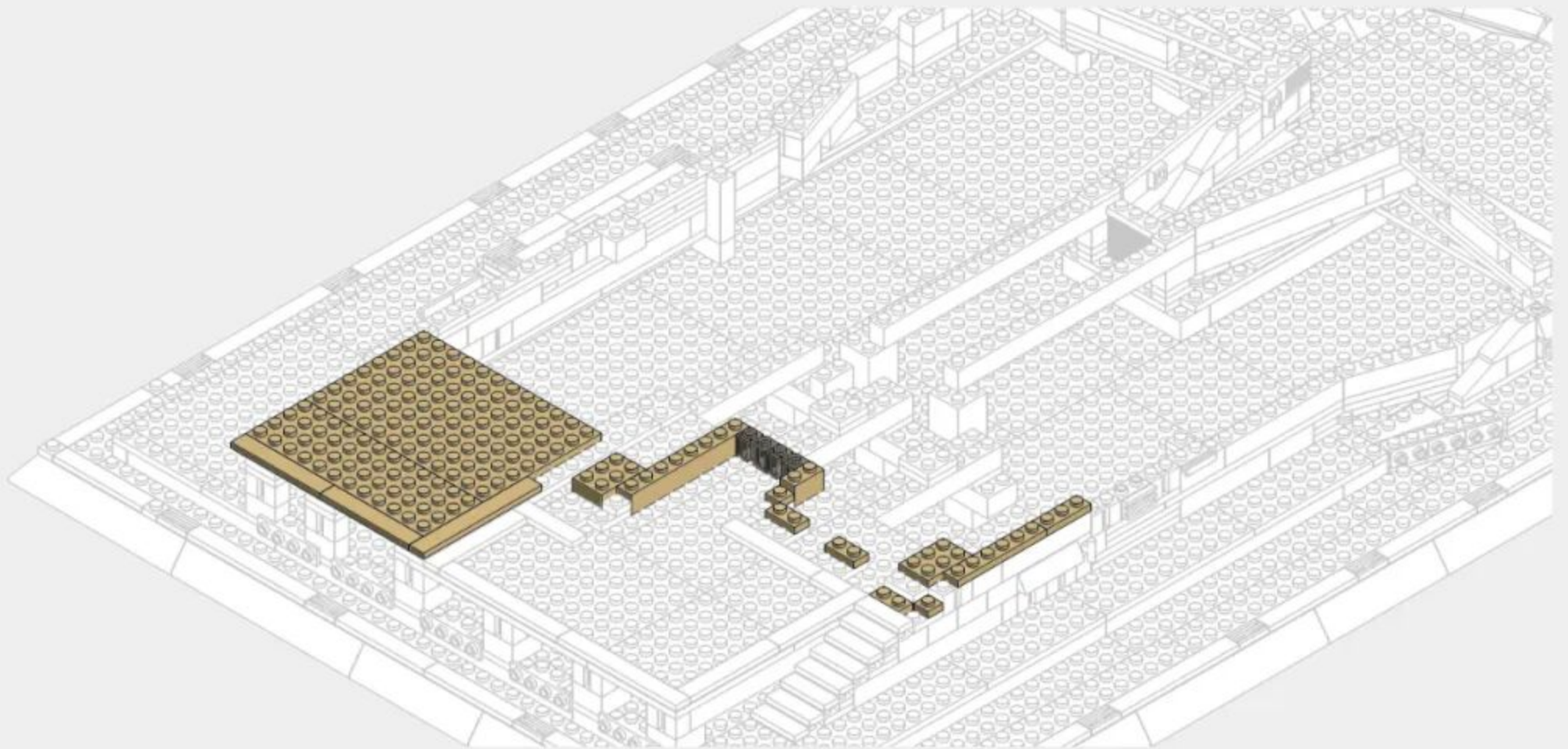
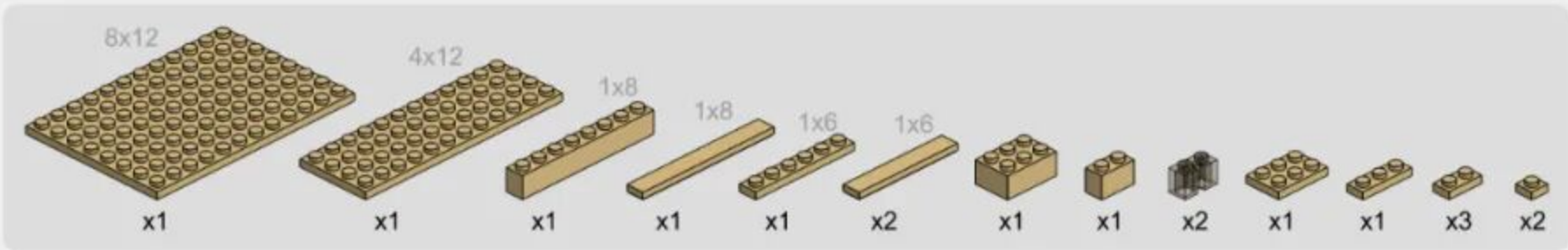

4-3

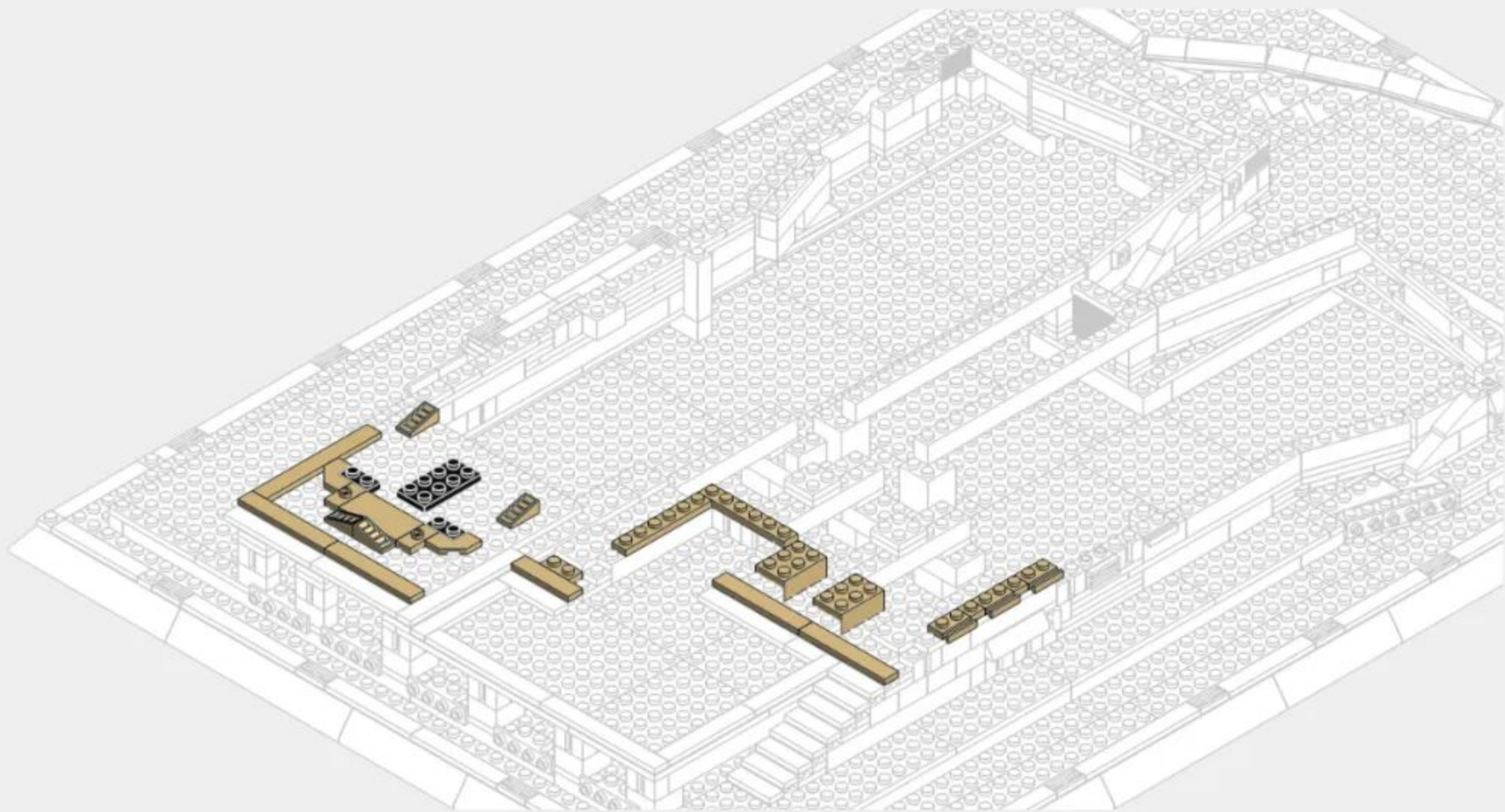
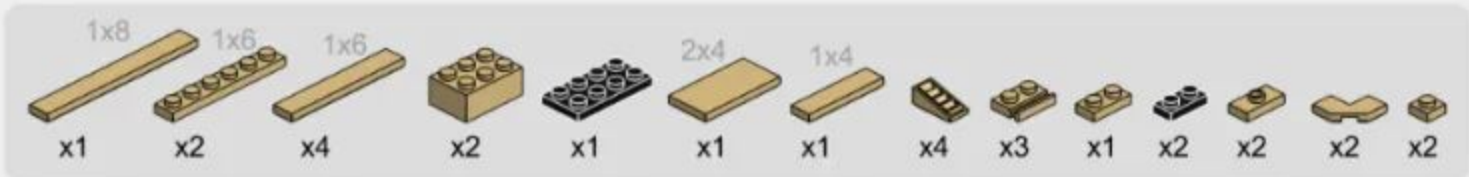

4-4

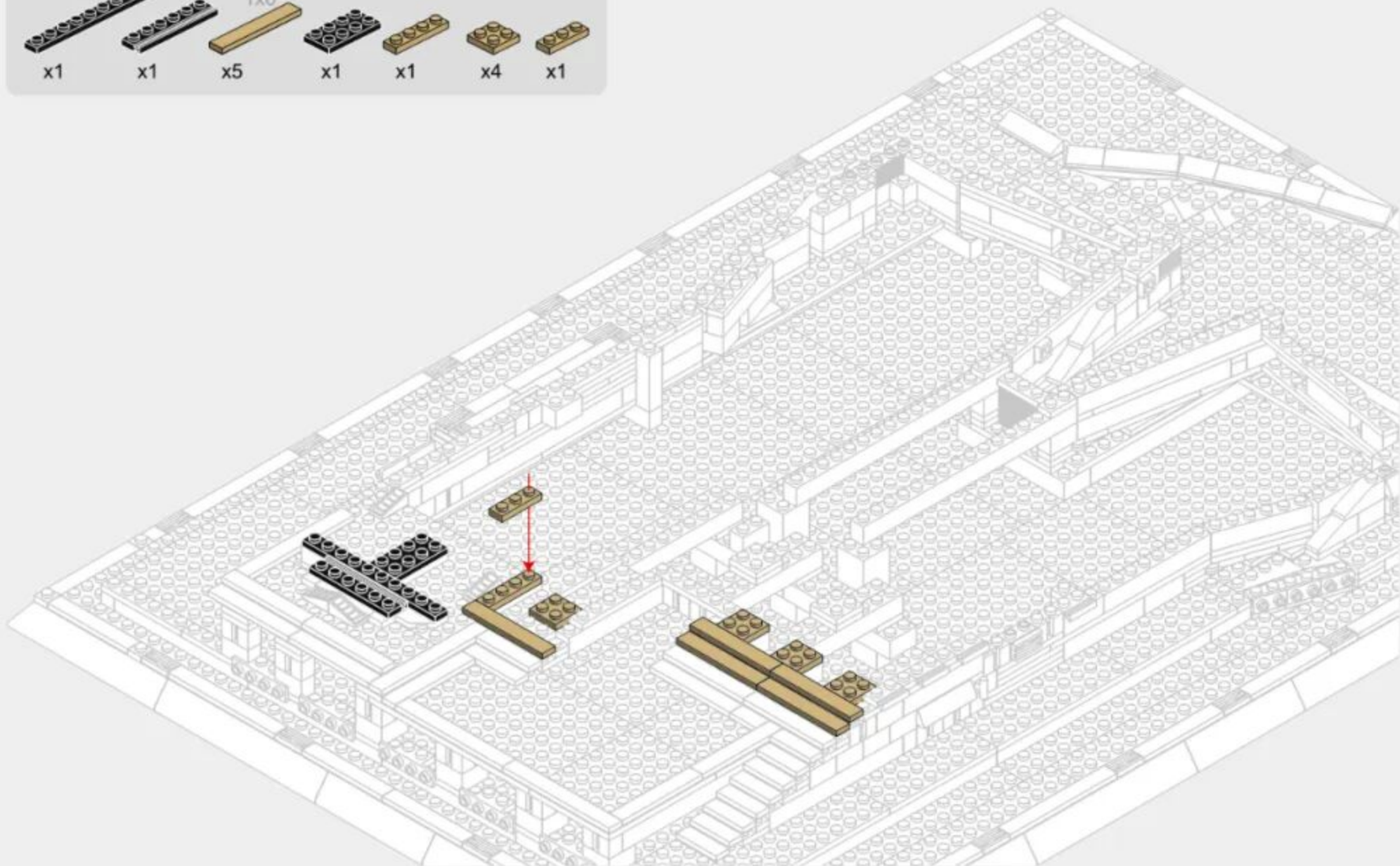
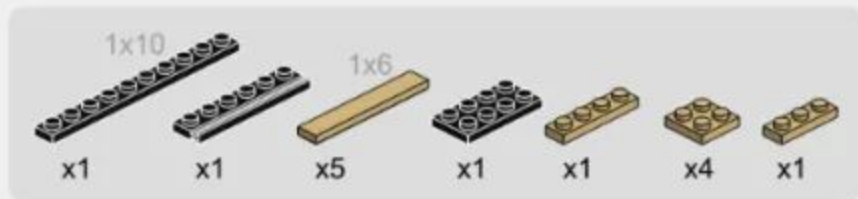

4-5

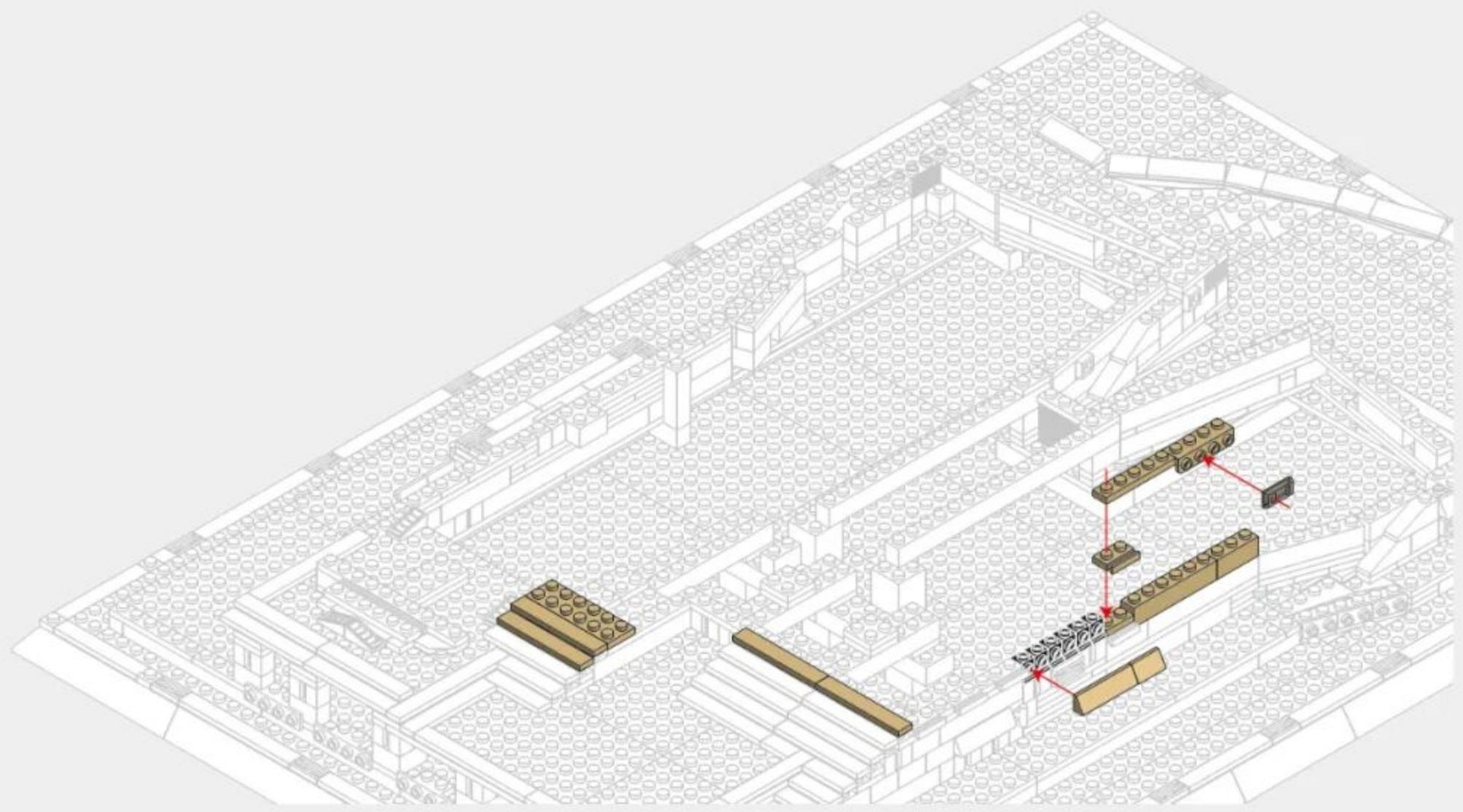
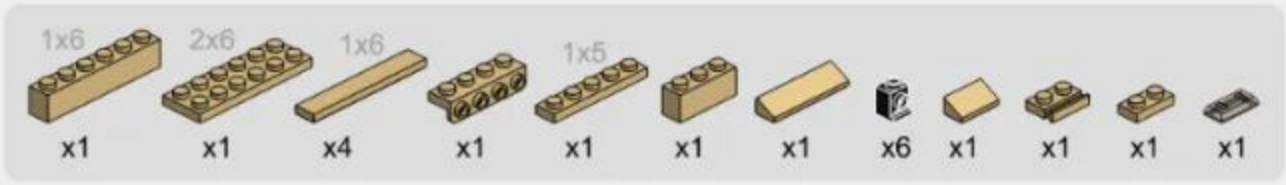

4-6

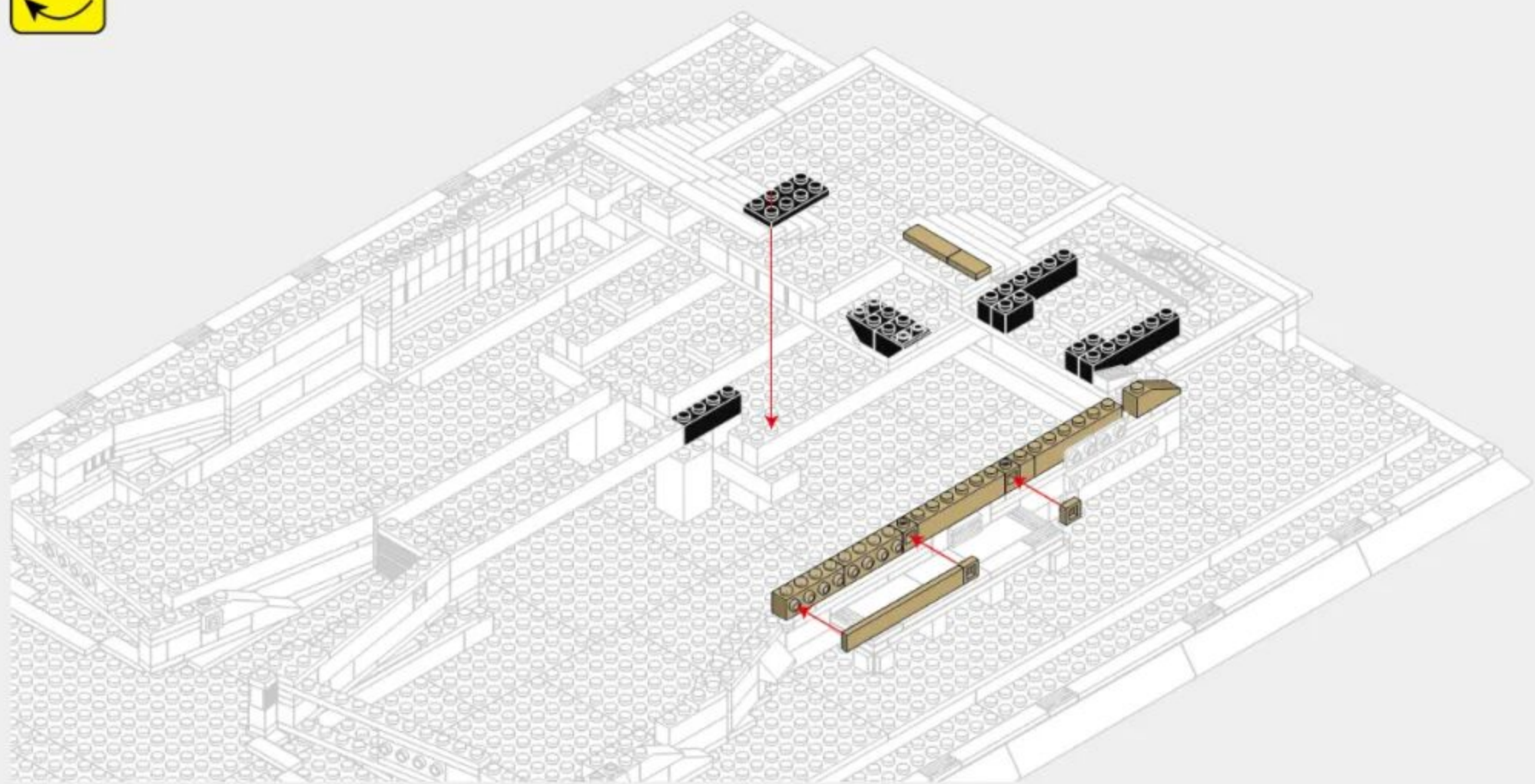

4-7

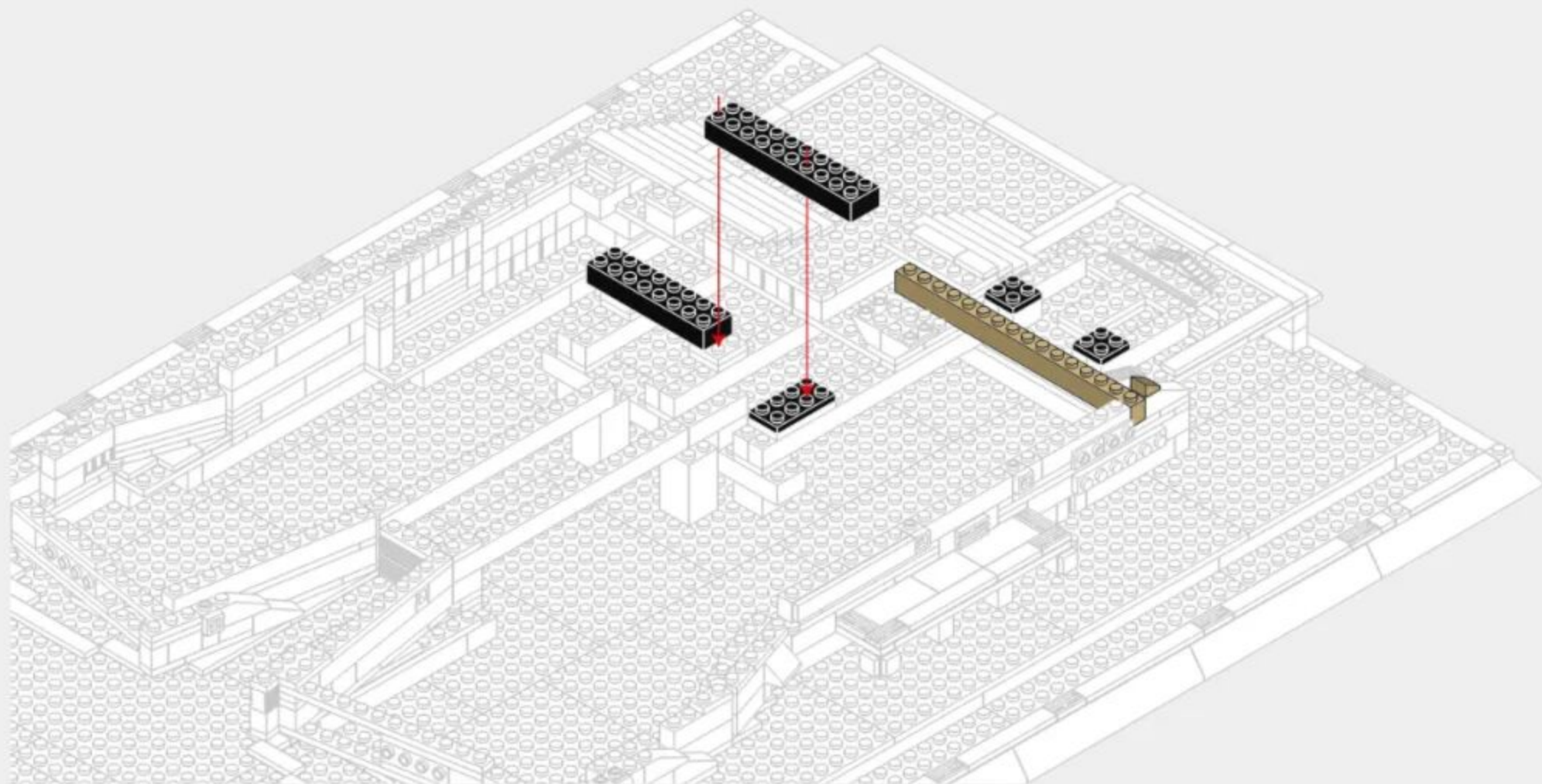
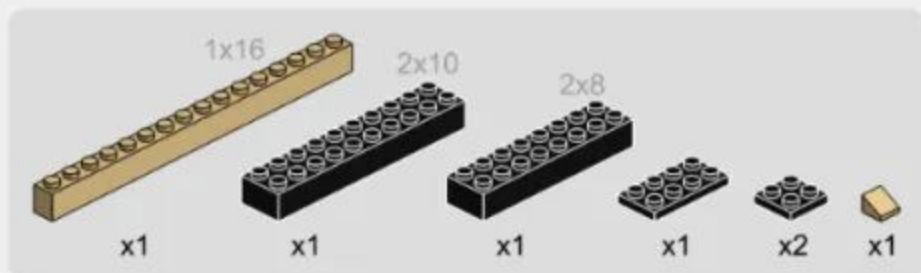

4-8

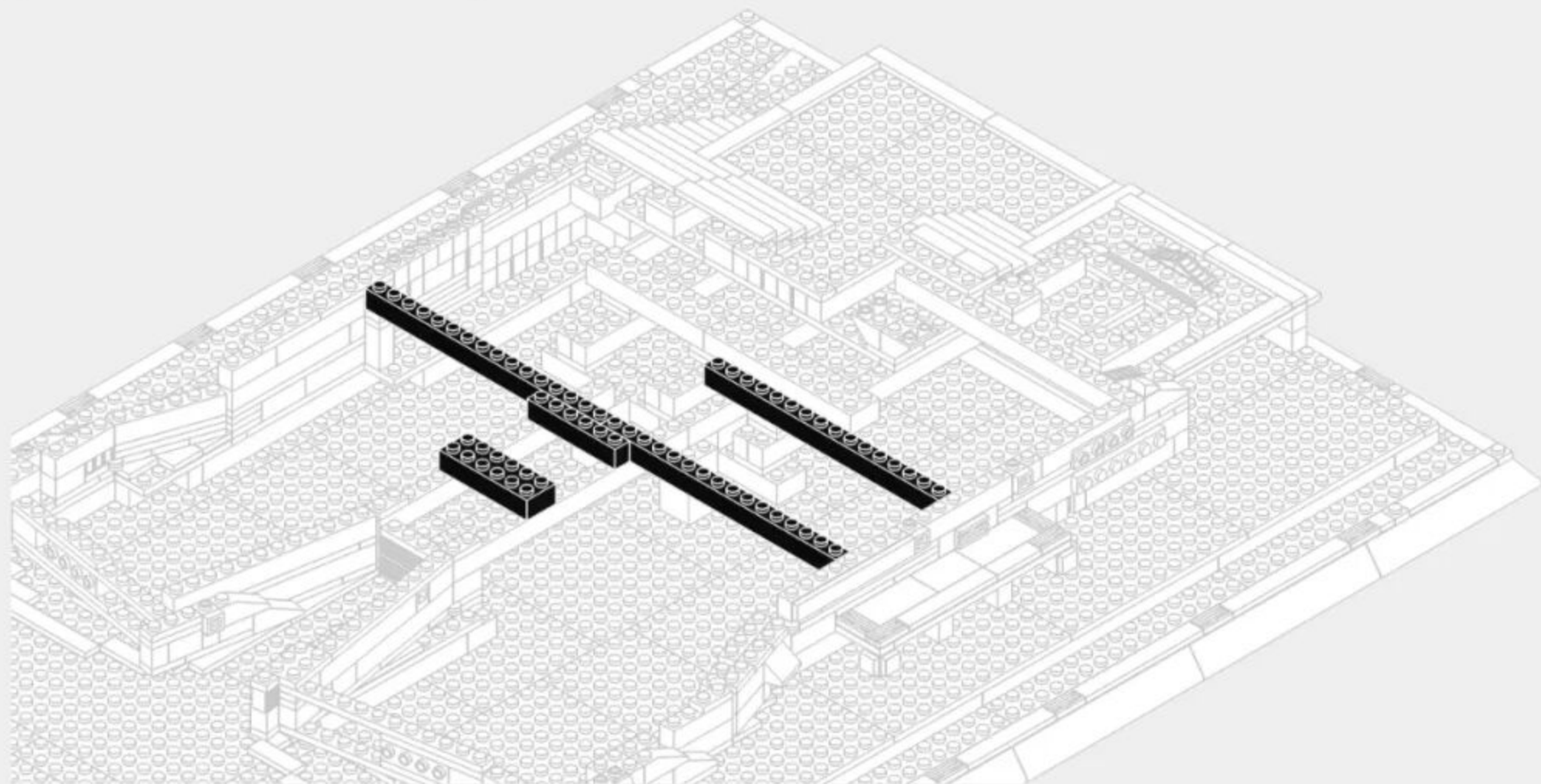
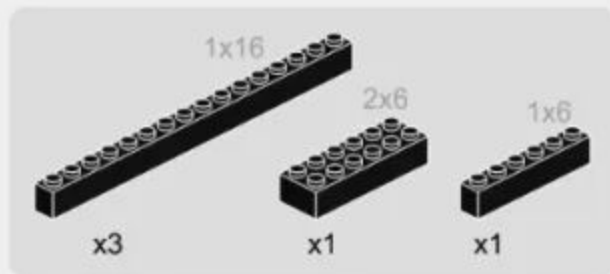

4-9

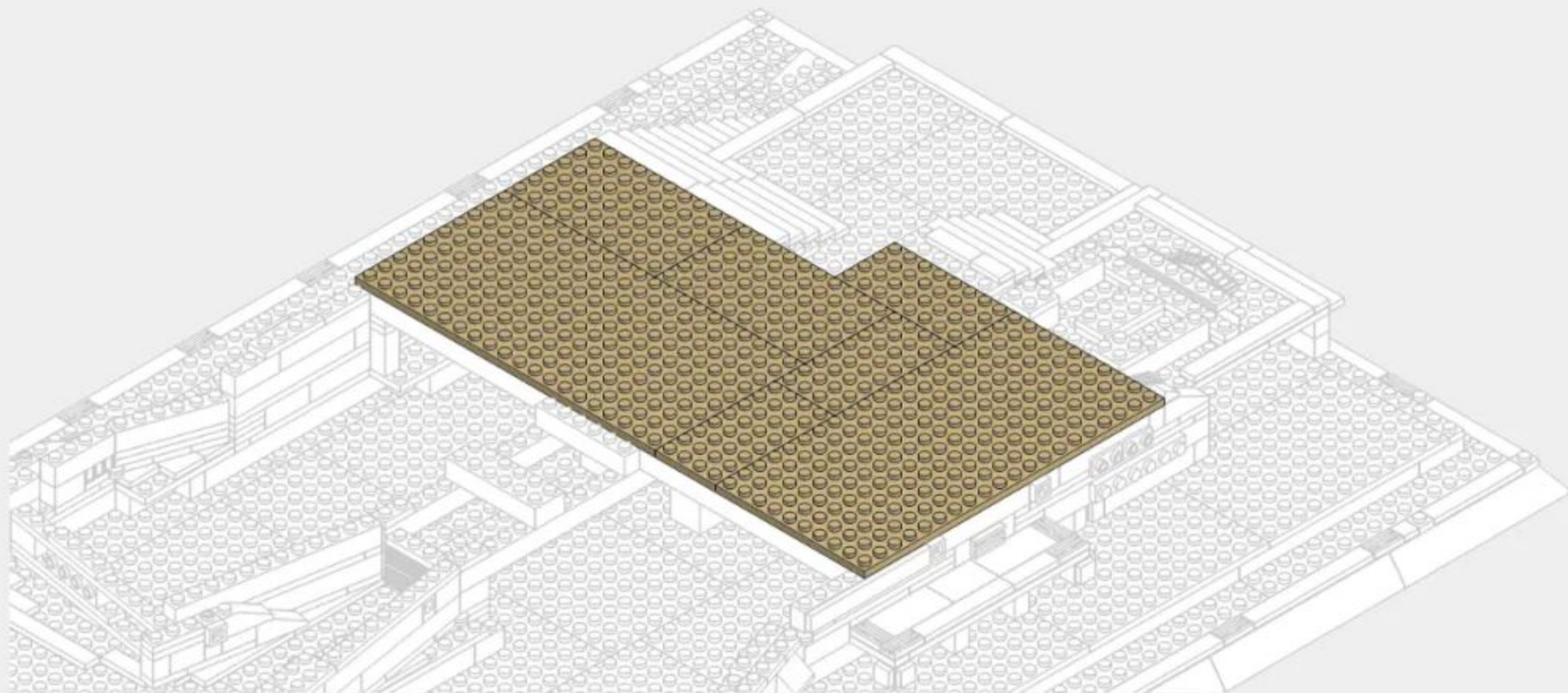
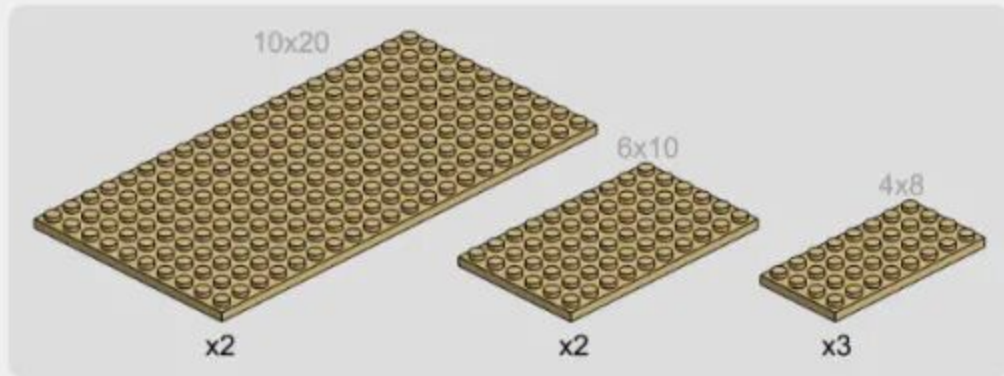

# 4-10

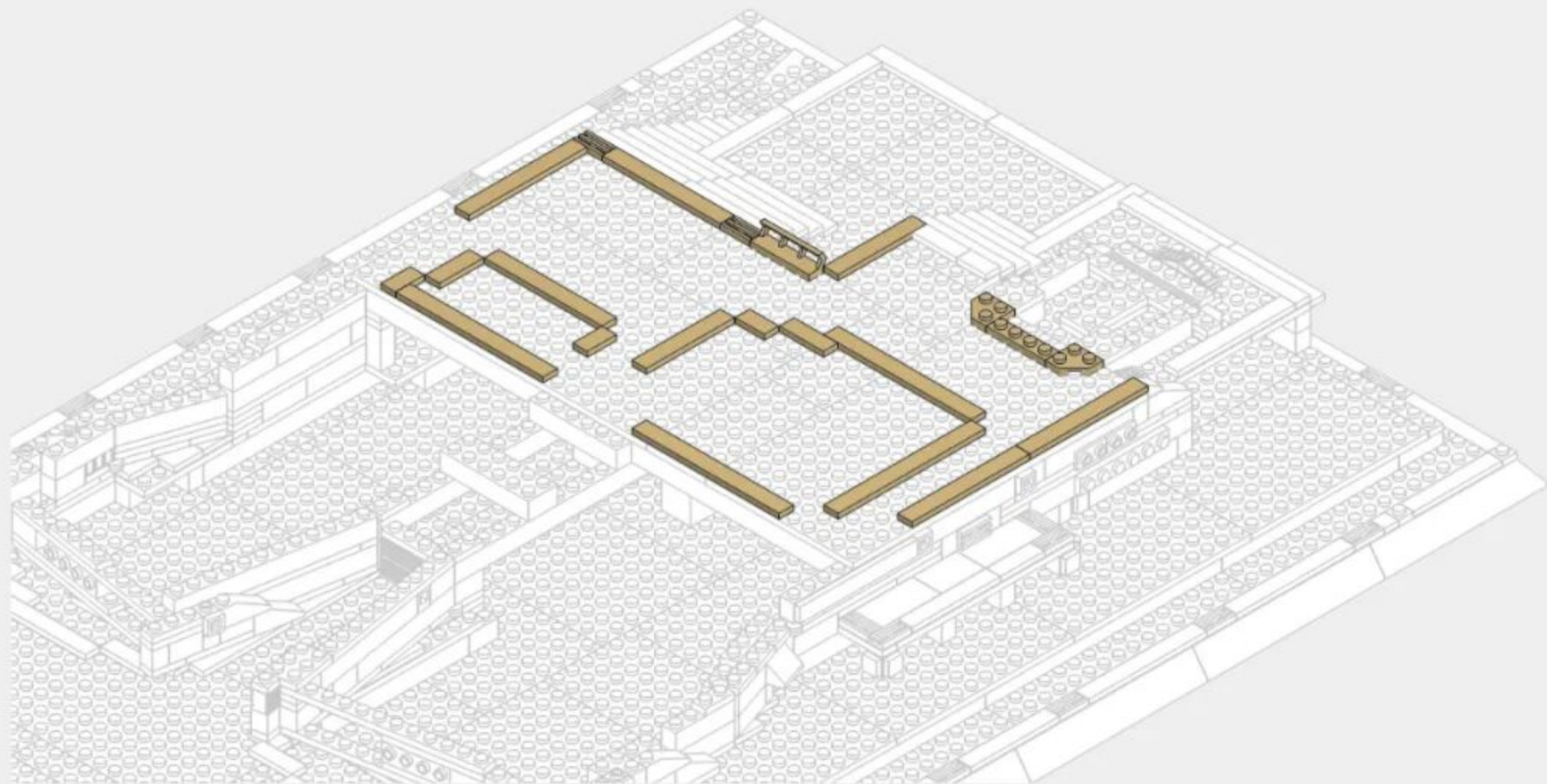
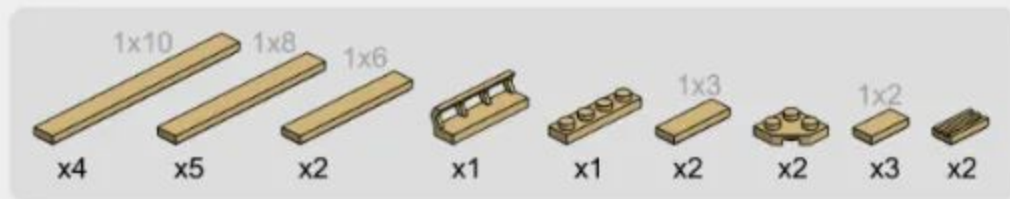

4-11

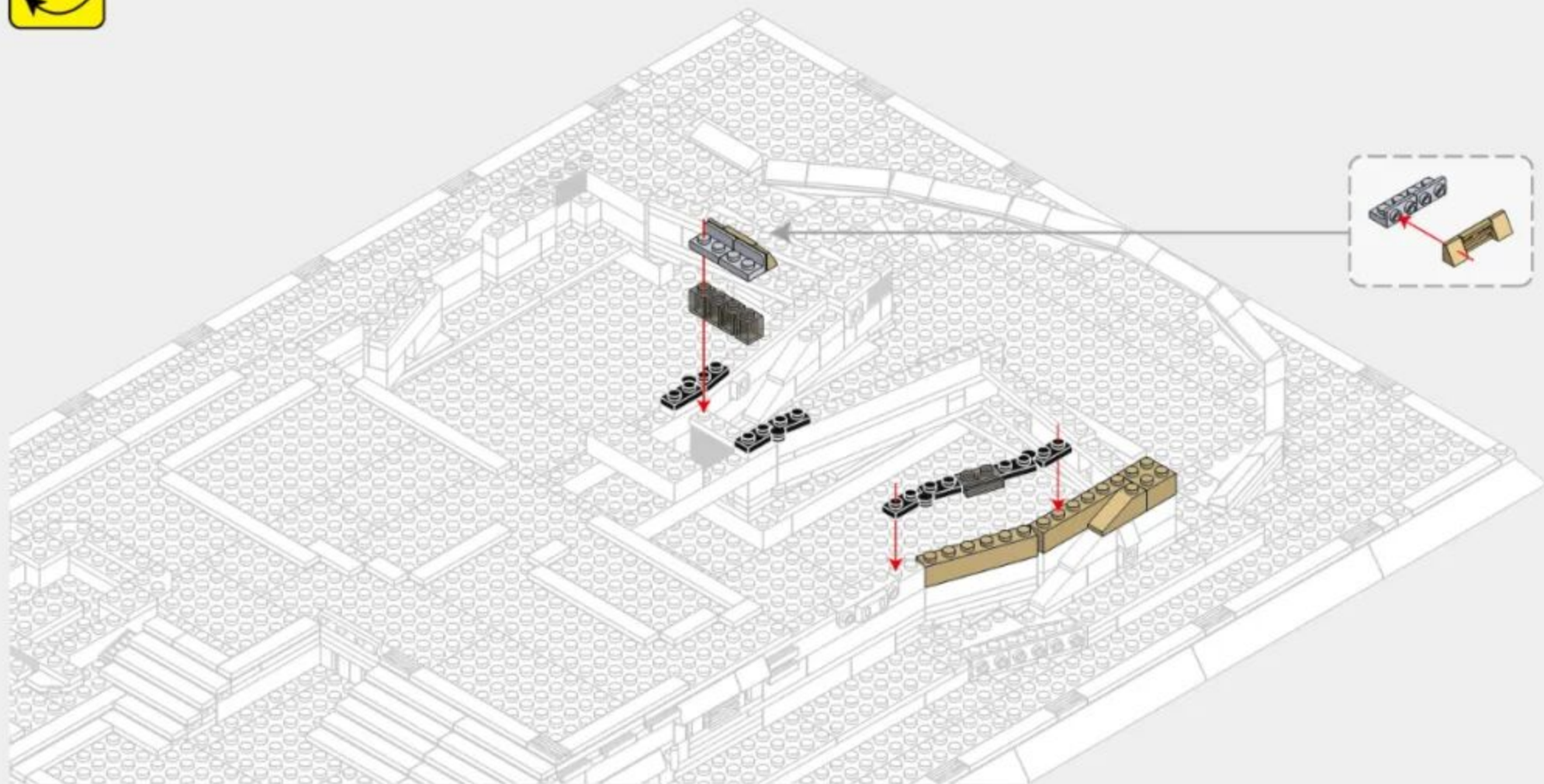

4-12

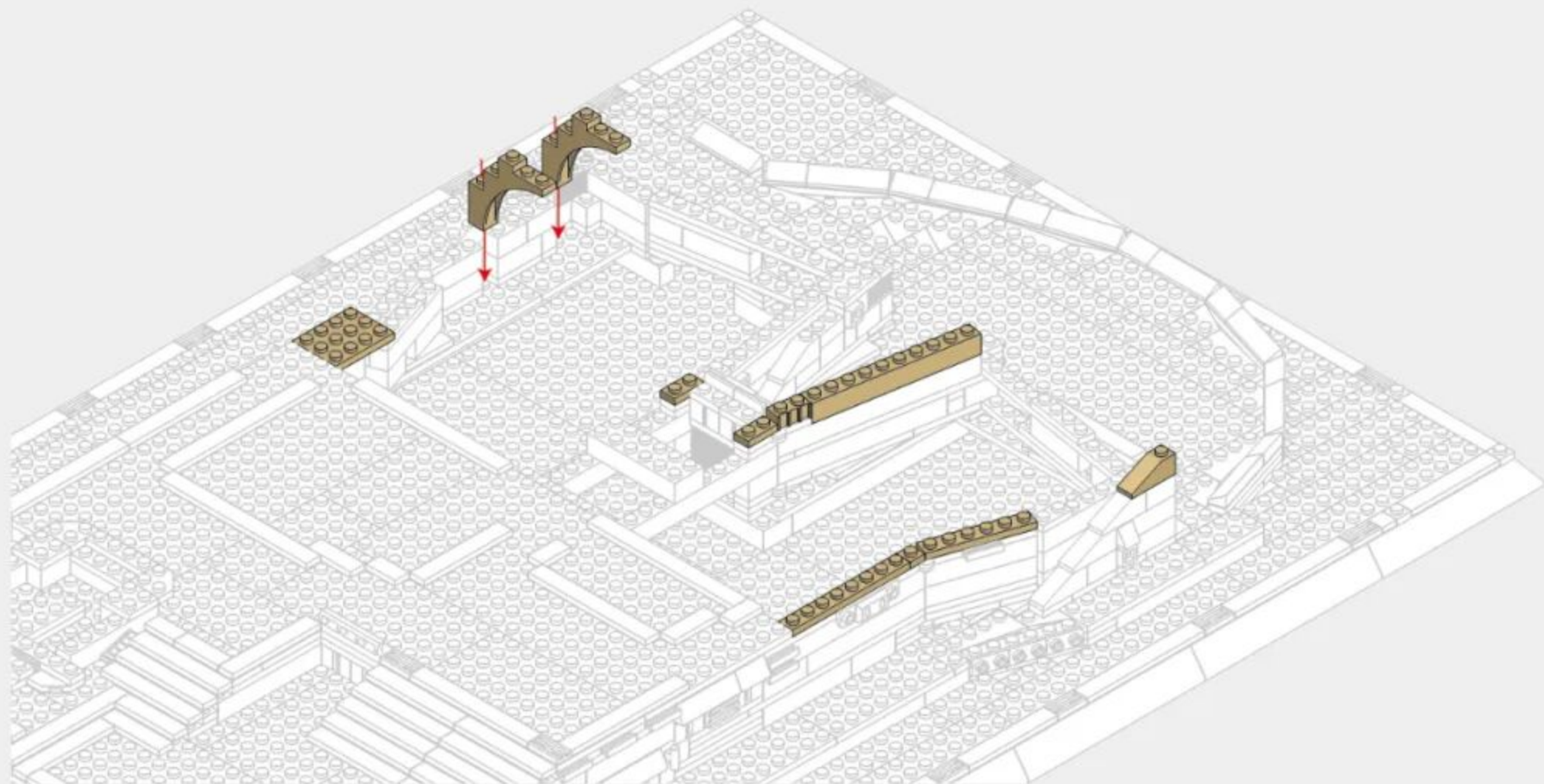
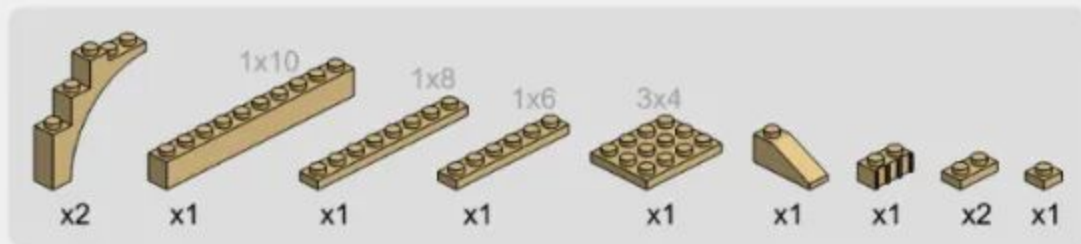

4-13

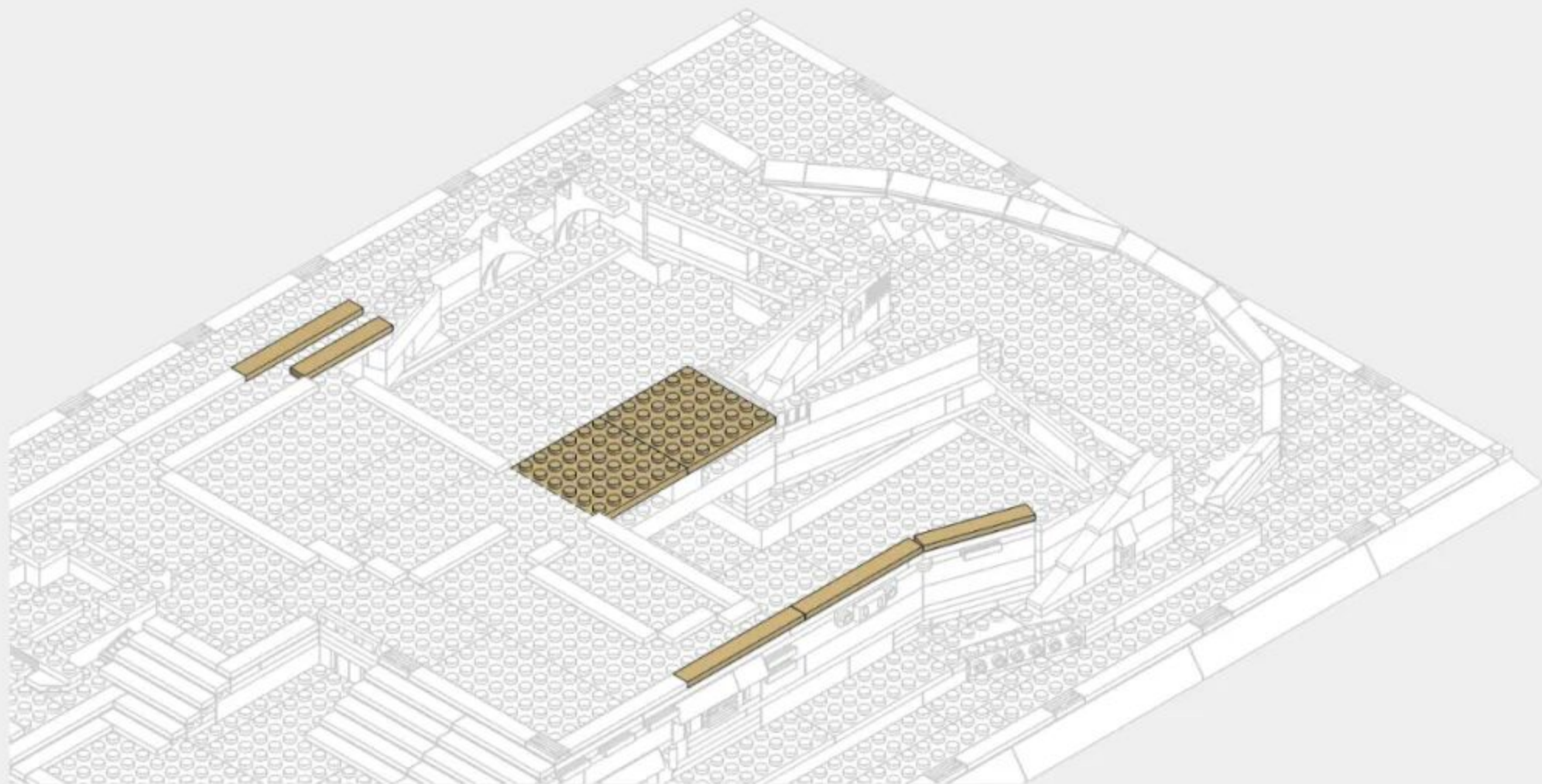
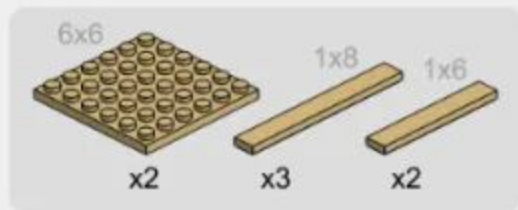

# 4-14

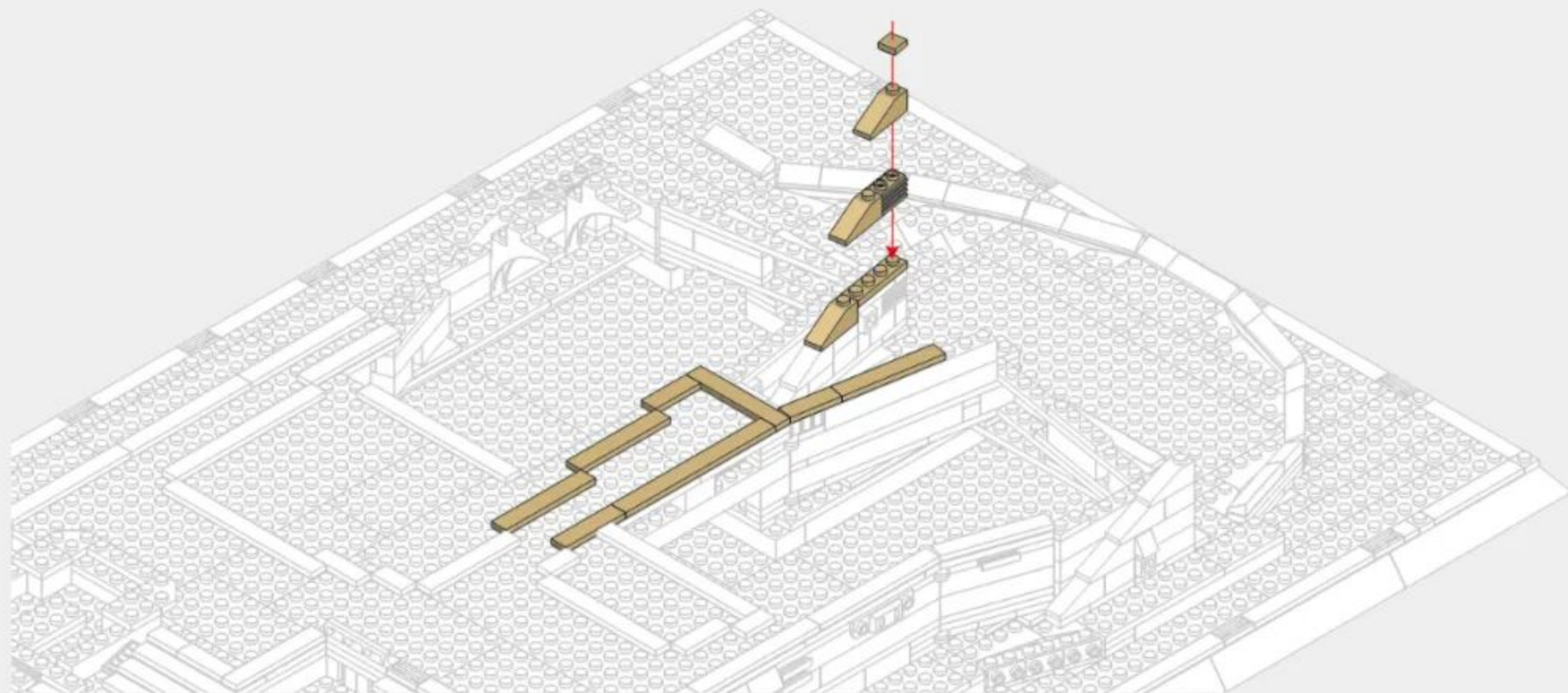
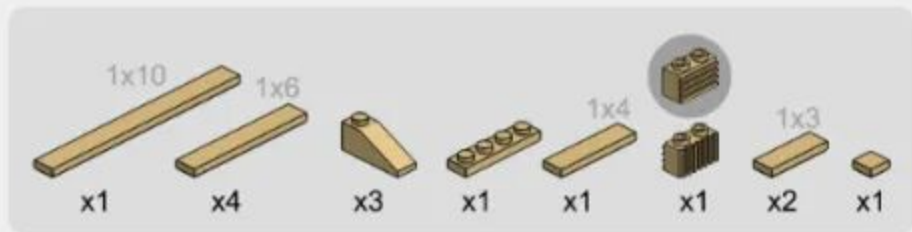

# 4-15

- 1x8 (tan) x1
- 1x8 (tan) x1
- 1x8 (tan) x1
- Black 1x4 with holes x1
- Tan wedge x1
- 1x5 (tan) x1
- Tan 1x2 x1
- Tan 1x2 x1
- Black 1x2 x1
- Tan 1x2 x1
- Black 1x2 x2
- Black 1x2 x1
- Tan 1x2 x1
- Tan 1x2 x1
- Tan 1x2 x1
- Black 1x2 x3
- Tan 1x2 x1

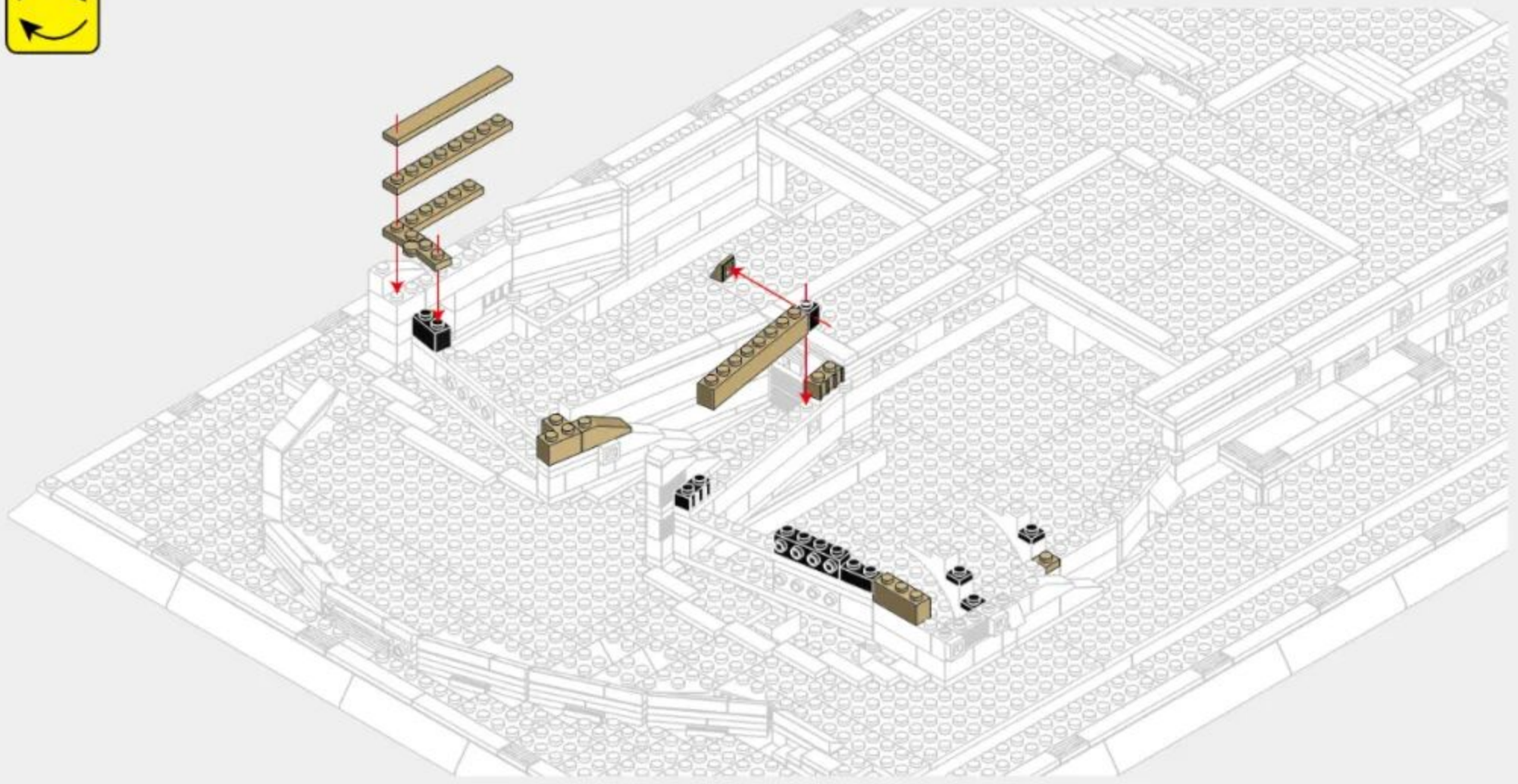

# 4-16

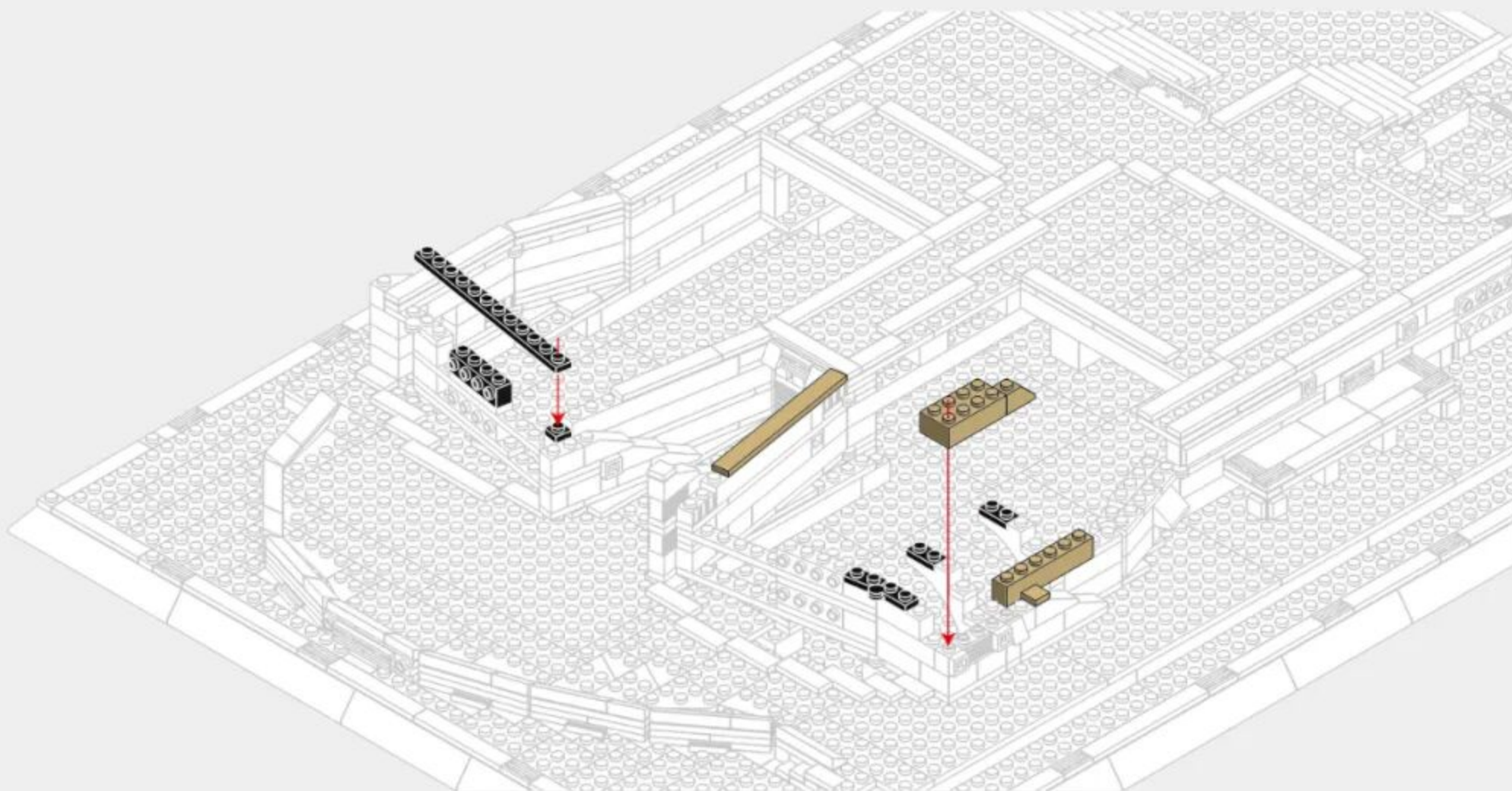
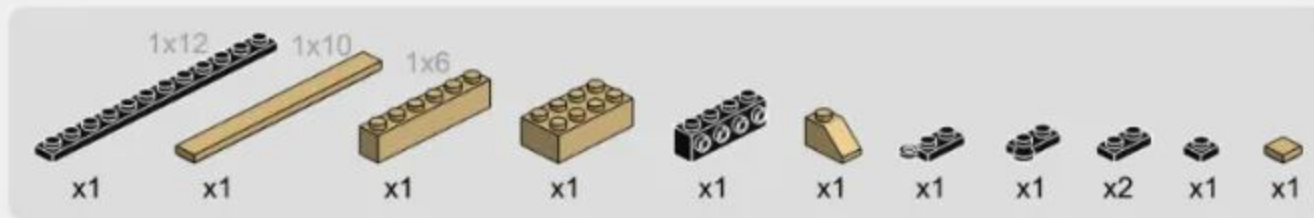



4-18

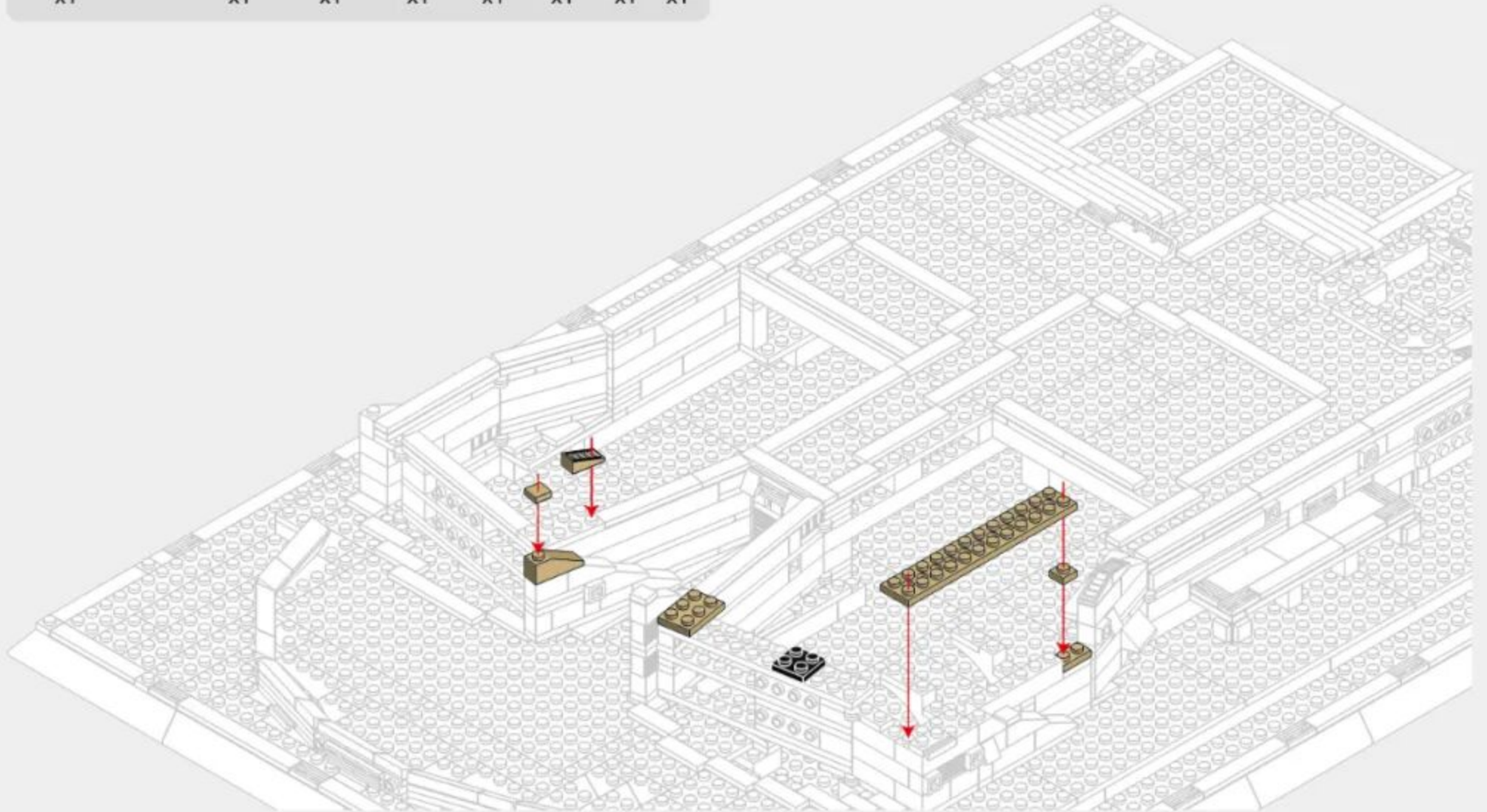

4-19

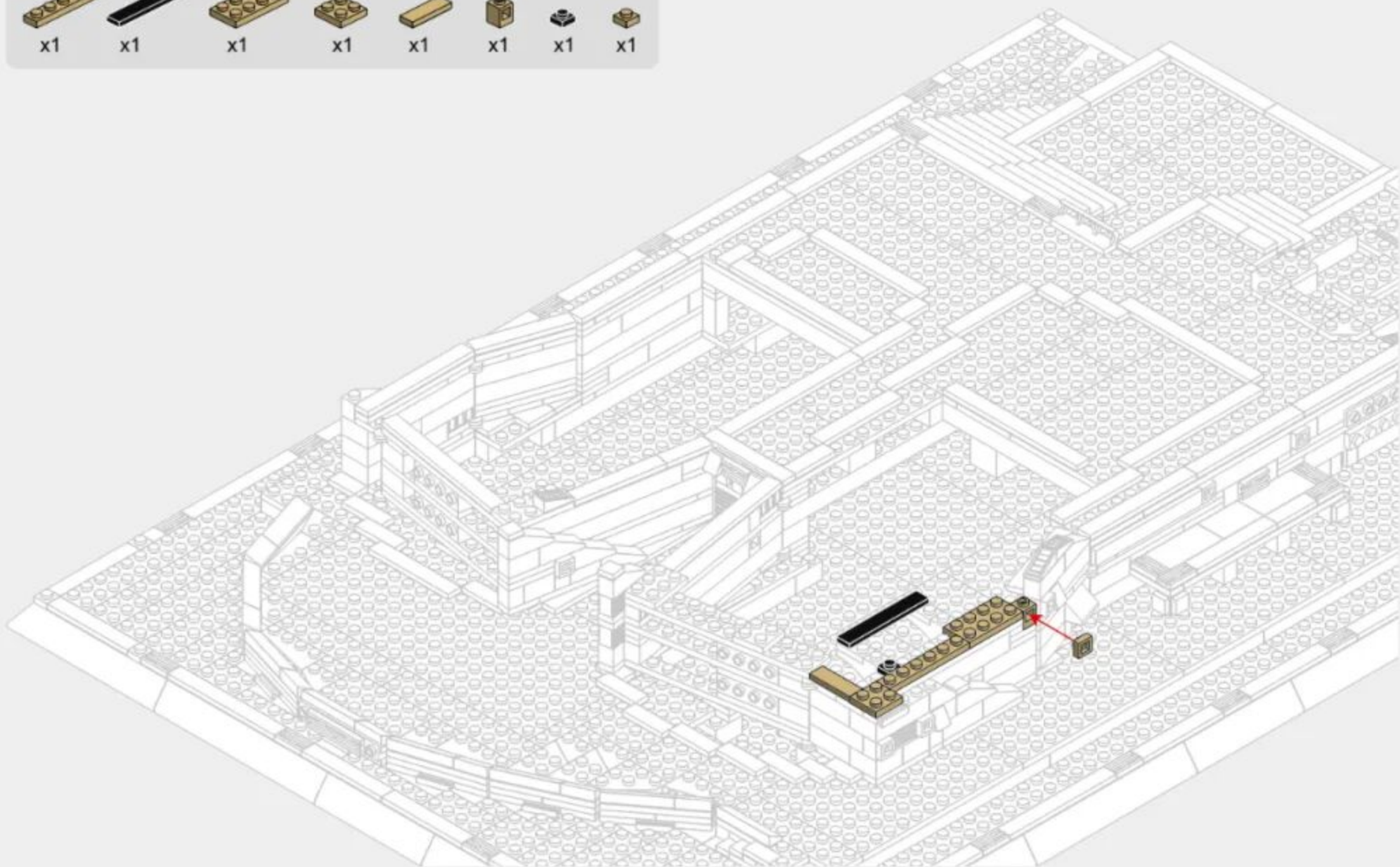

4-20

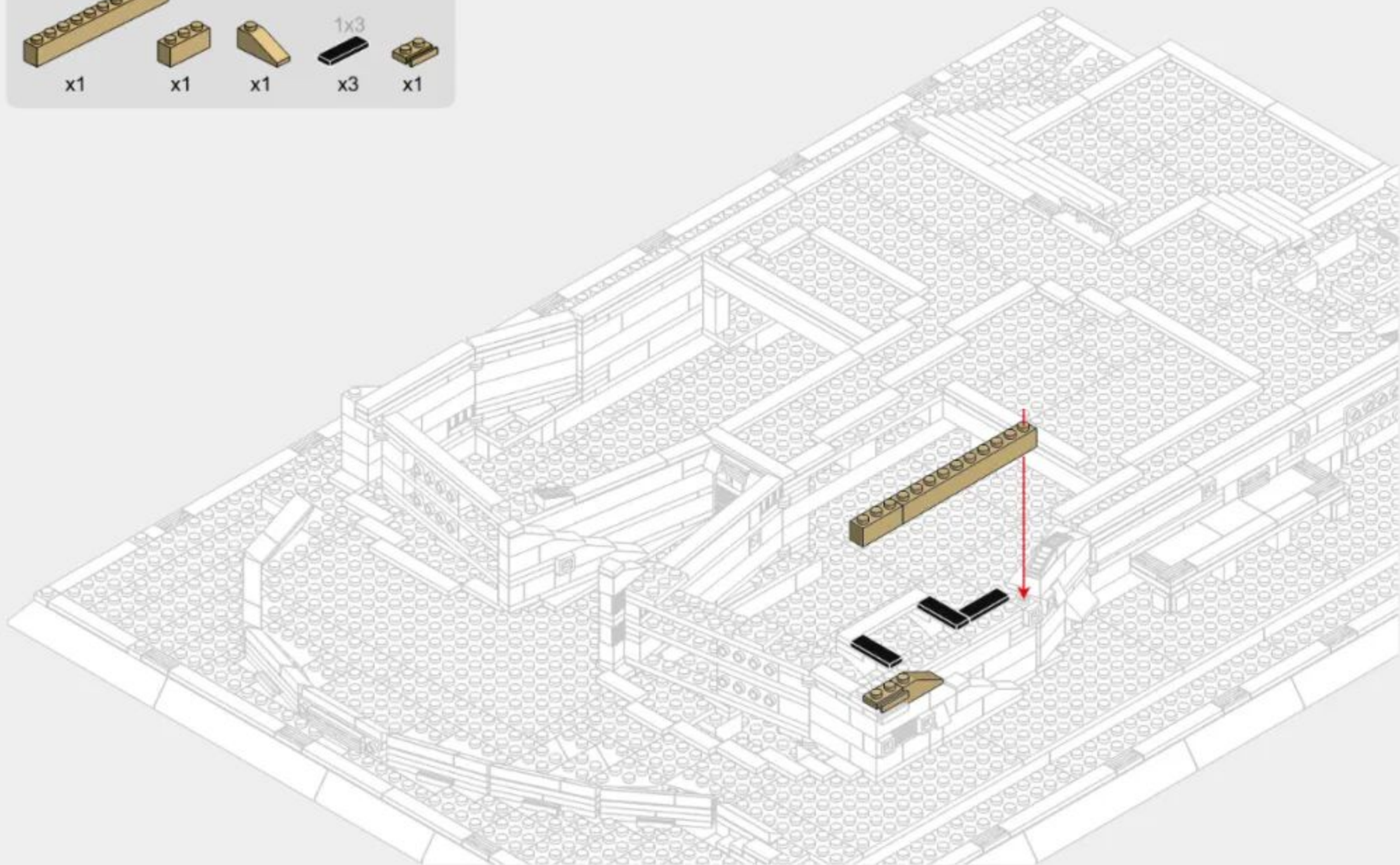
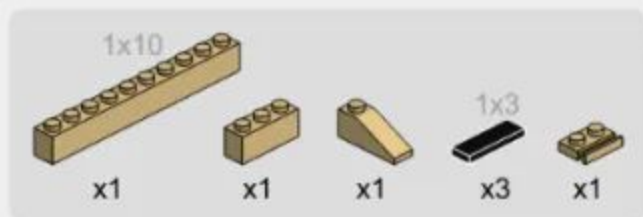

4-21

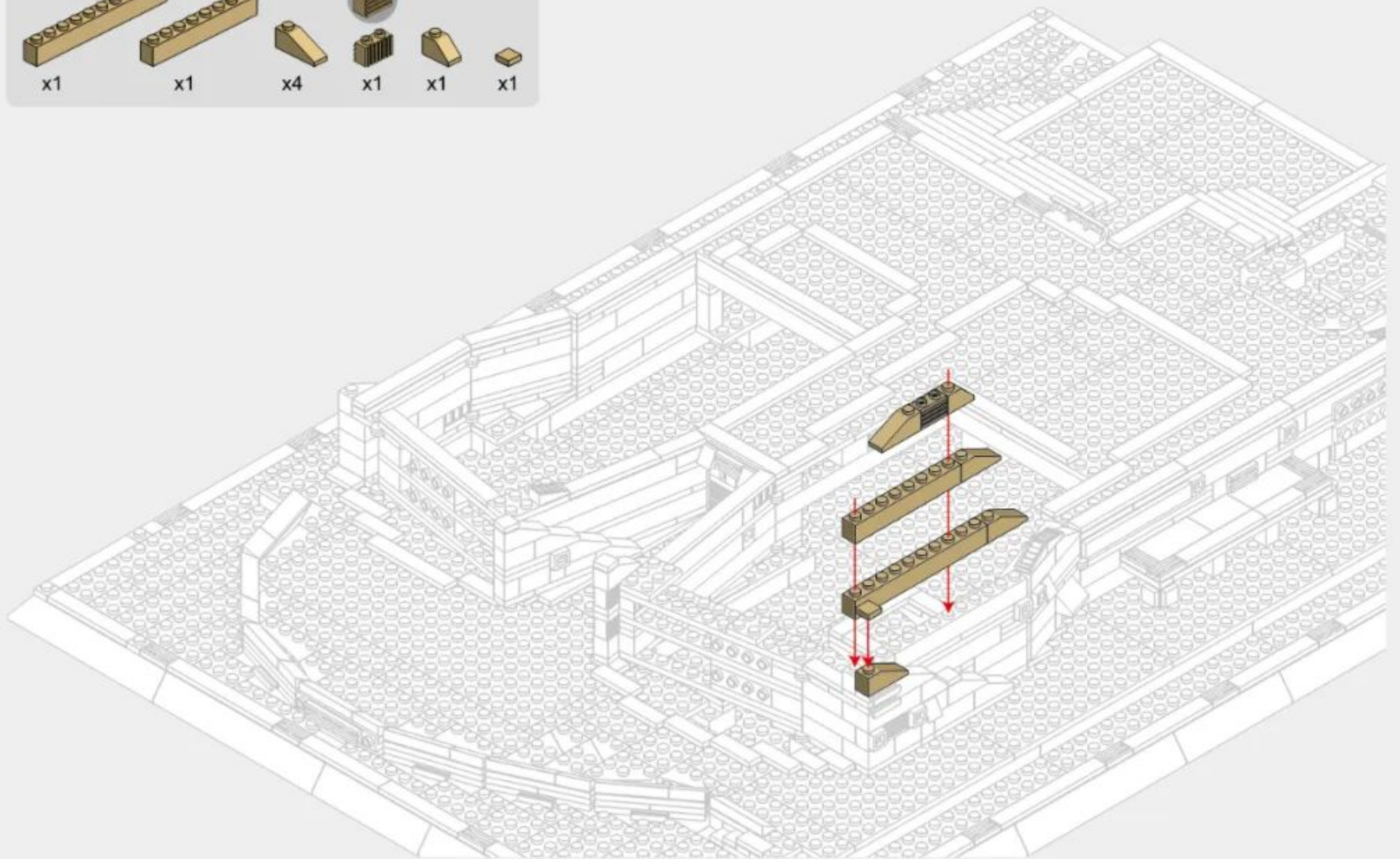
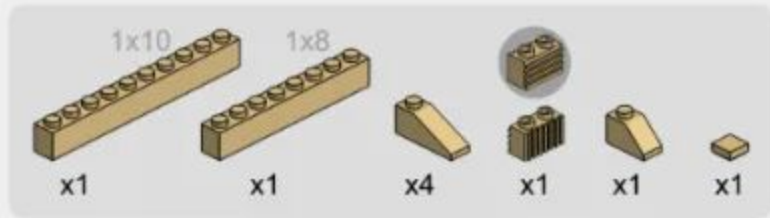



282 PCS

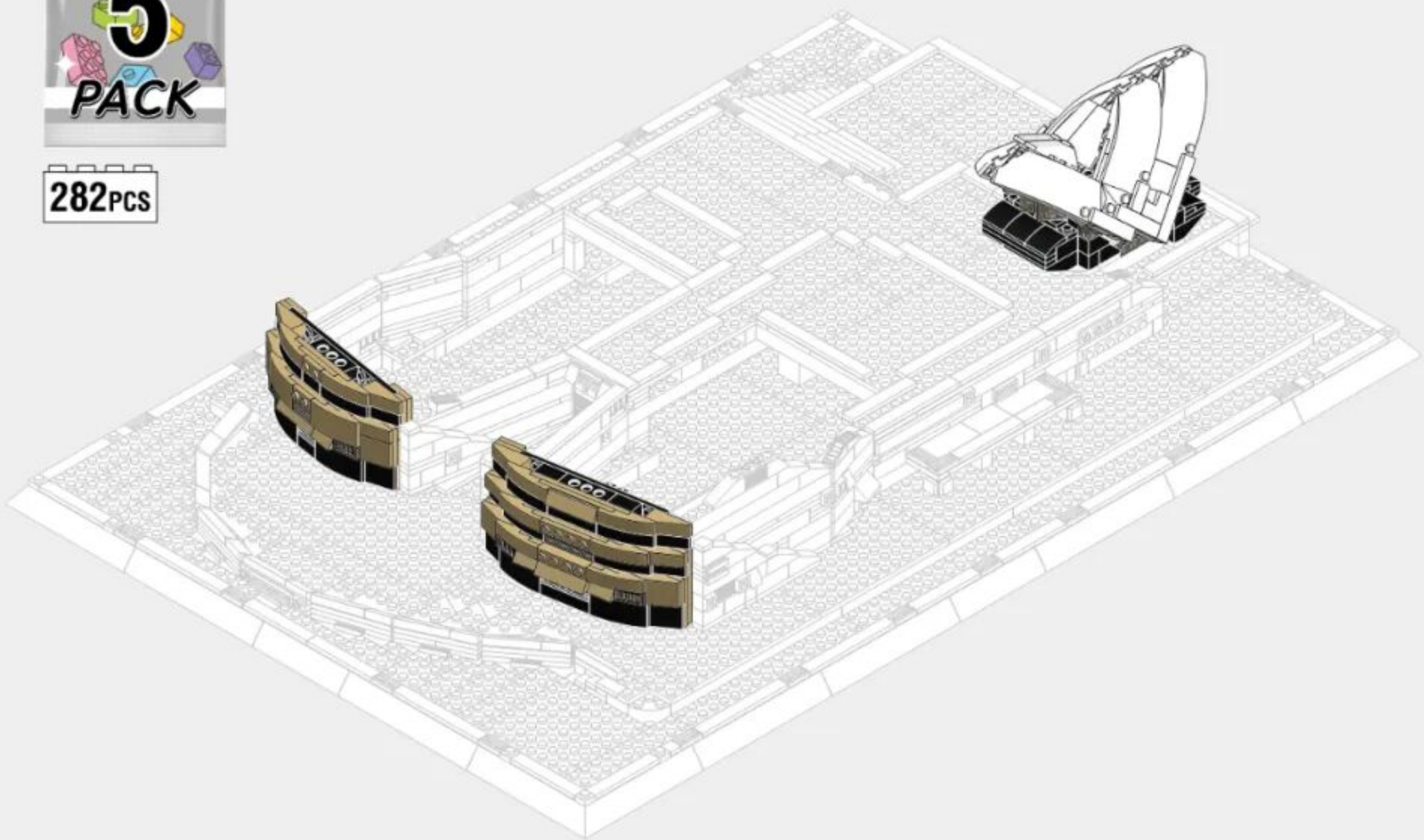

106

# 5-1

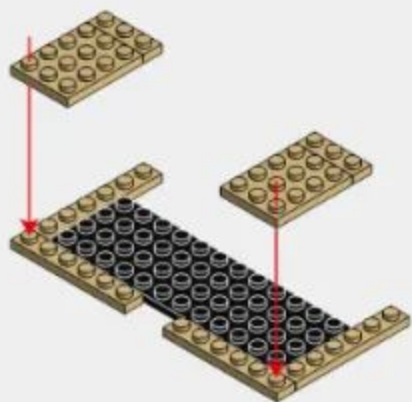
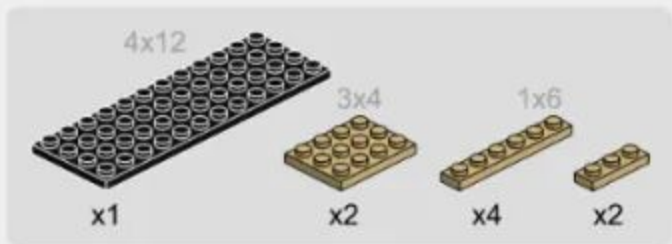

# 5-2

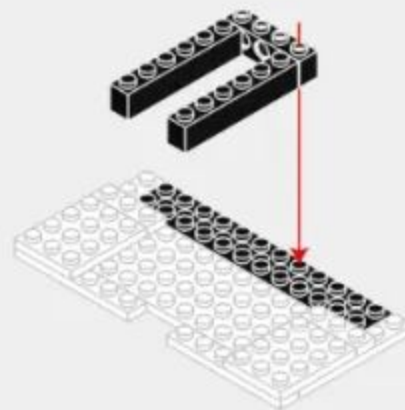
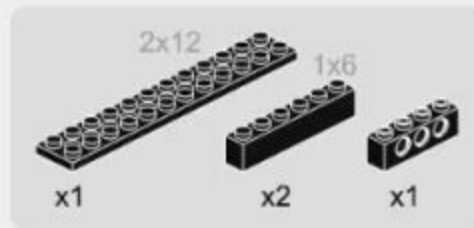

5-3

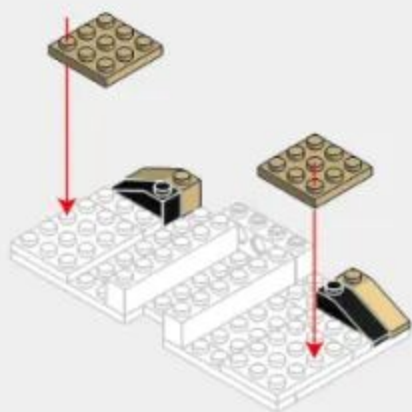

5-4

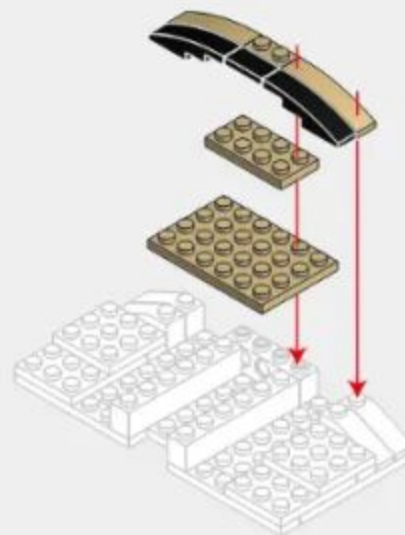

5-5

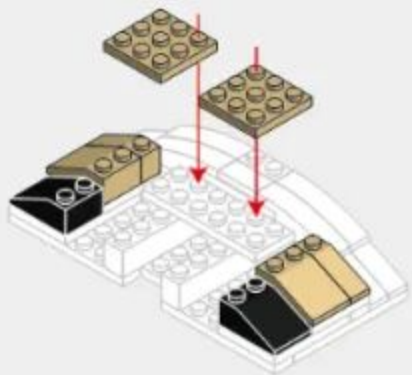

5-6

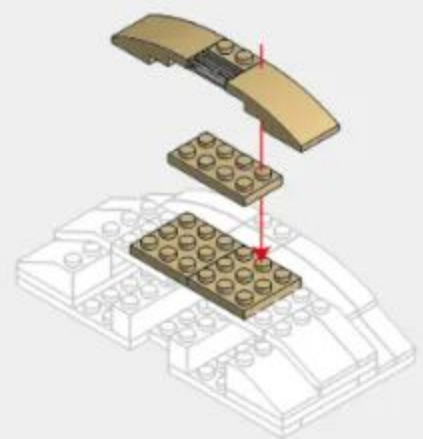

5-7

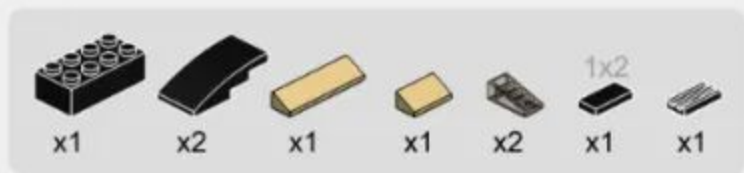

5-8

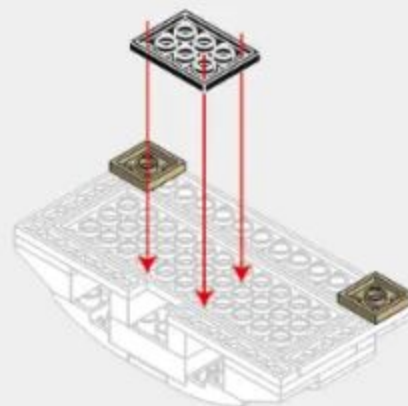
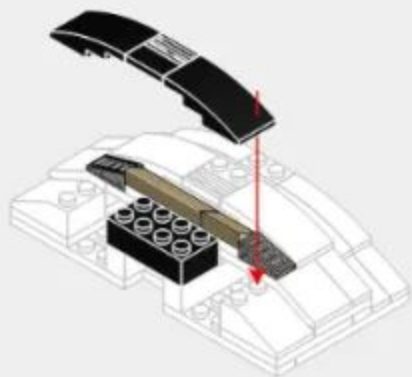

5-9

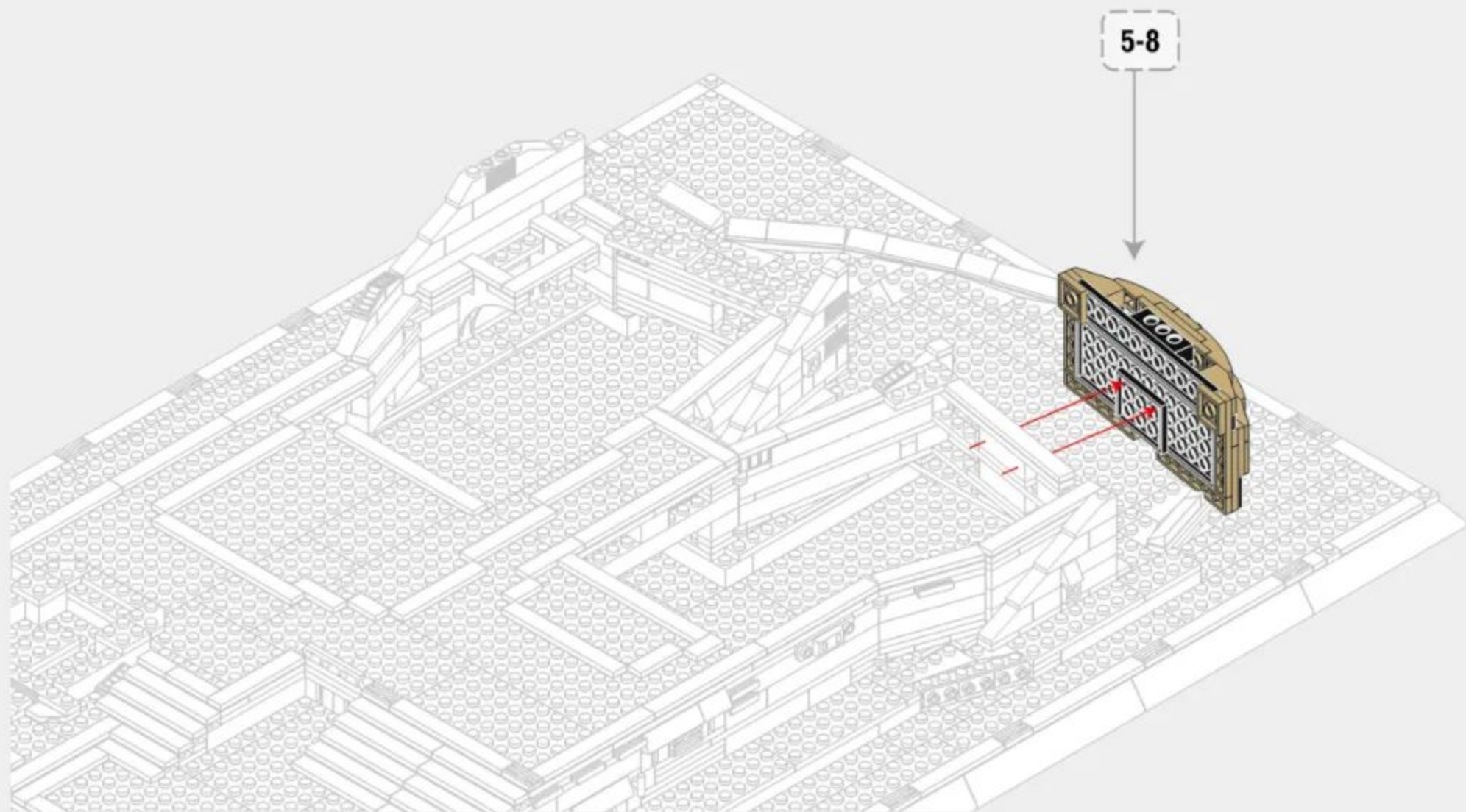

# 5-10

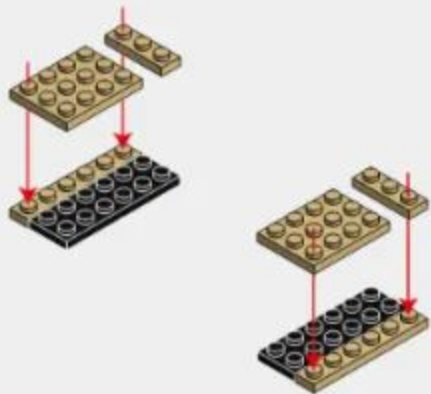

# 5-11

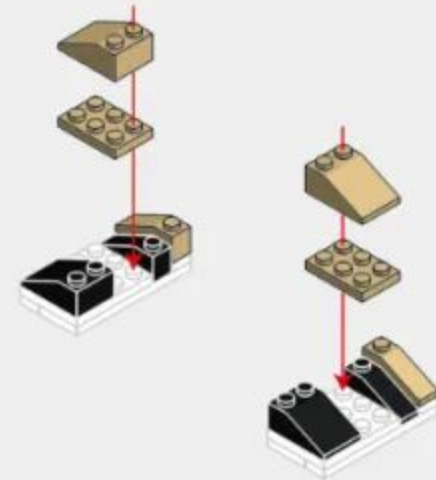

5-12

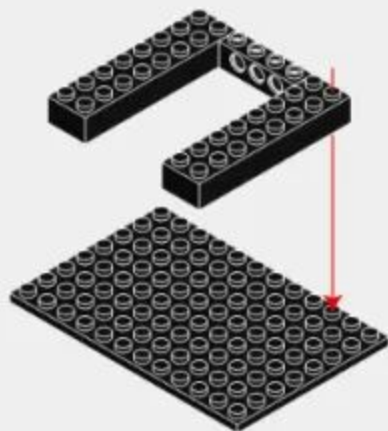
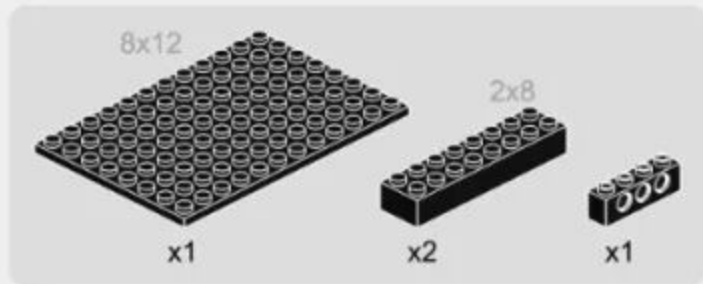

5-13

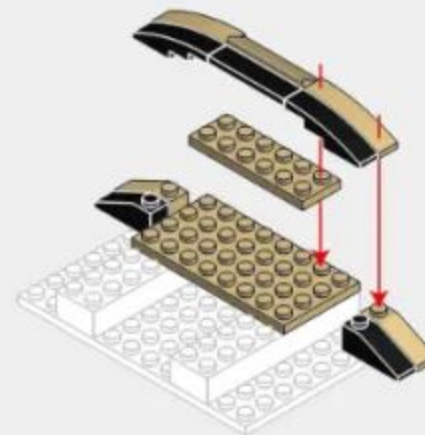

5-14

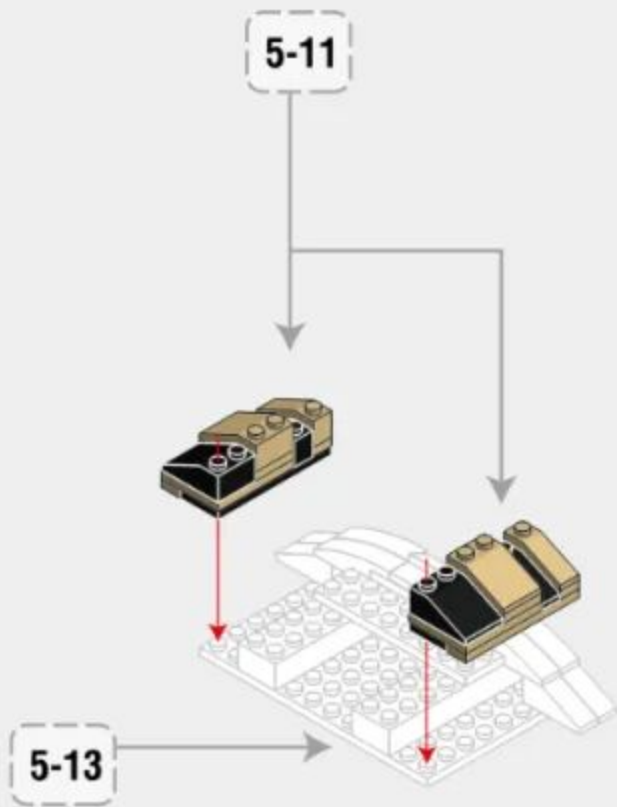

5-15

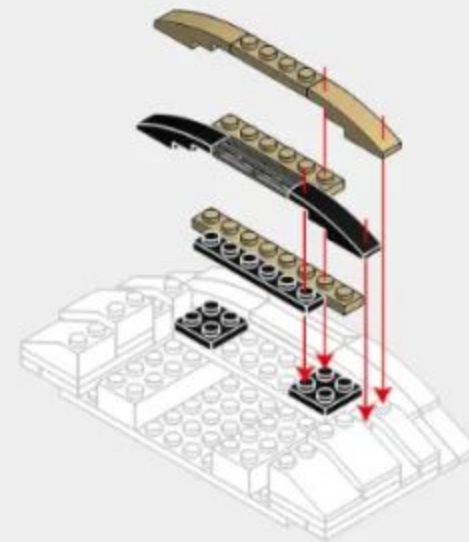

### 5-16

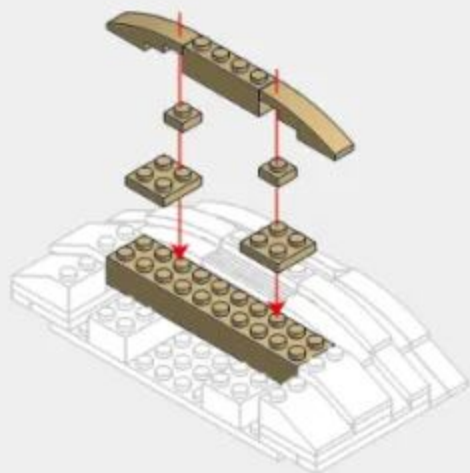
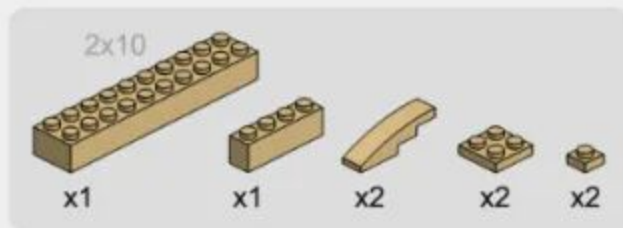

### 5-17

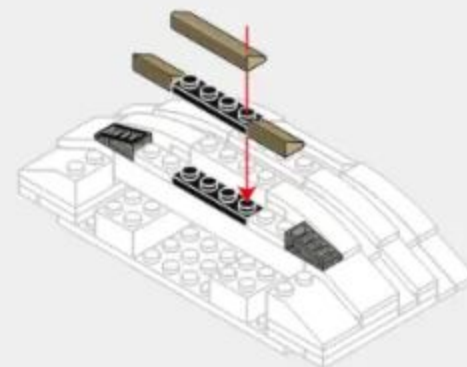

5-18

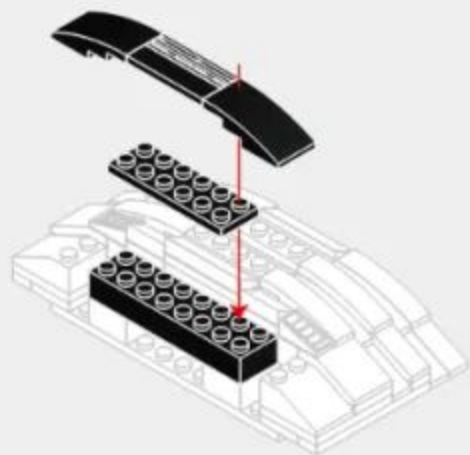

5-19

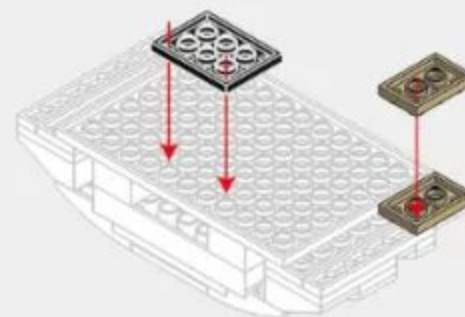

5-20



5-19

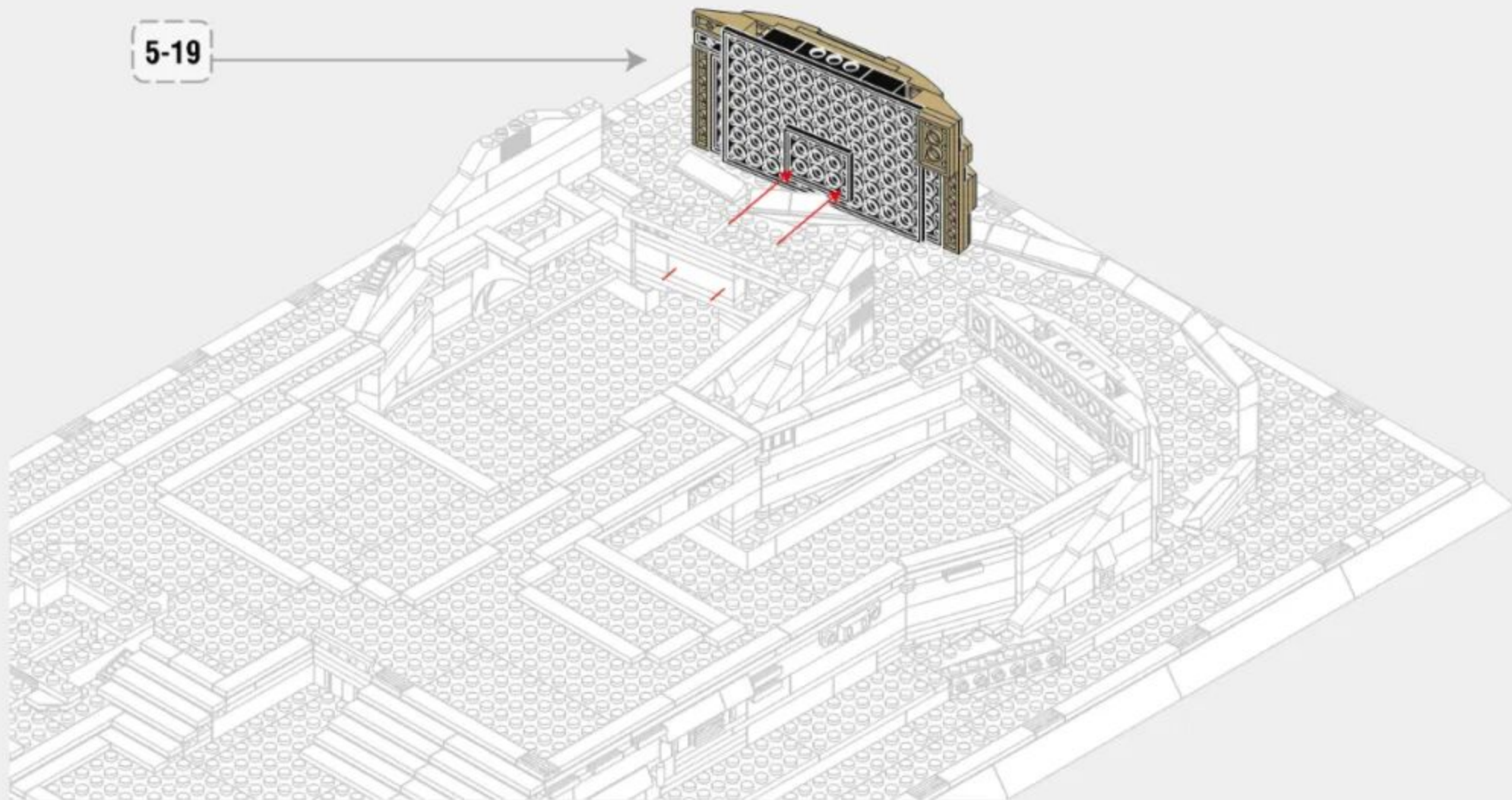

5-21

-  x1
-  x2
-  x1
-  x1

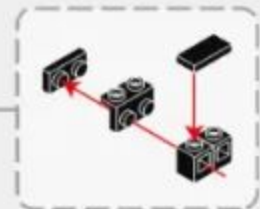
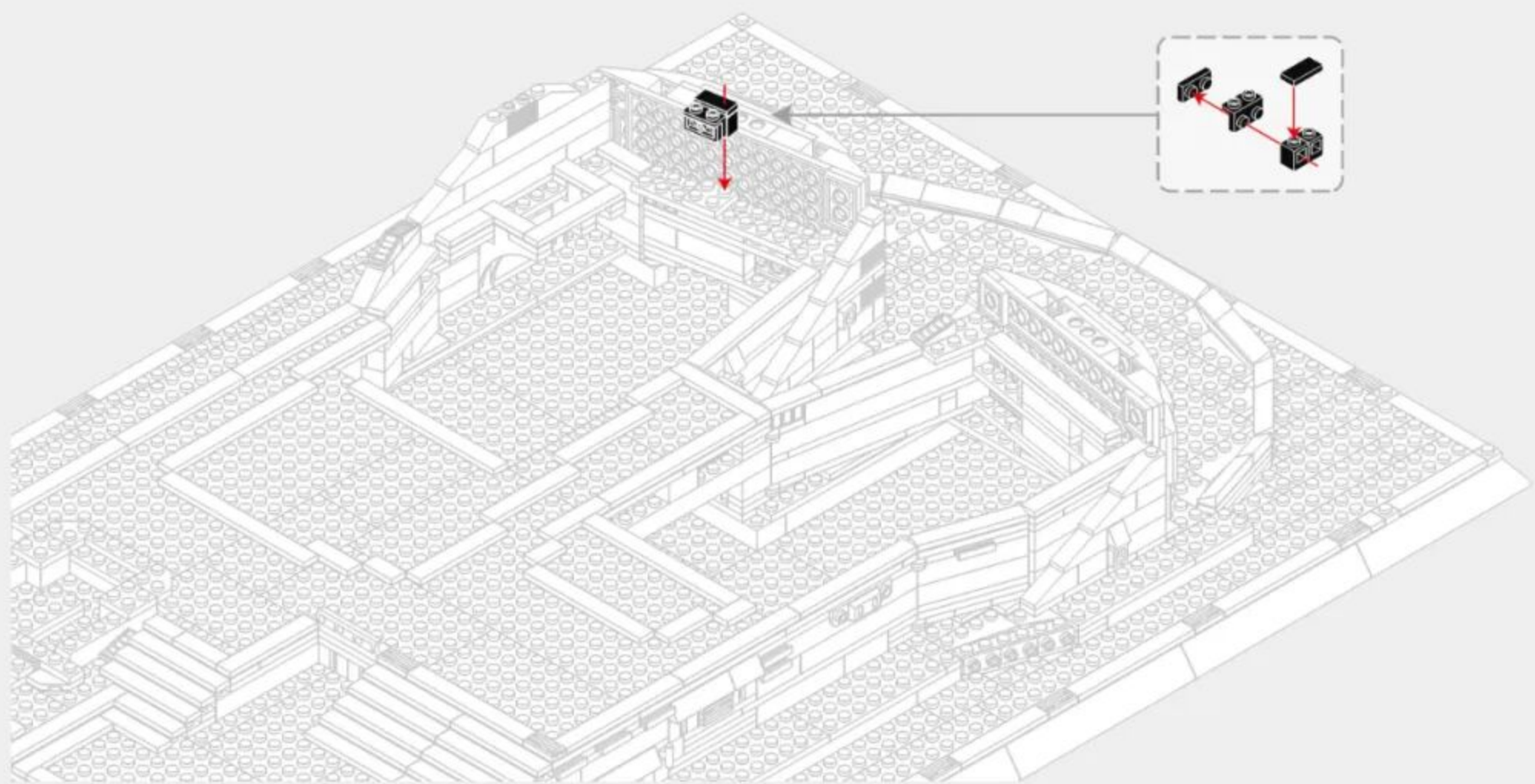

5-22

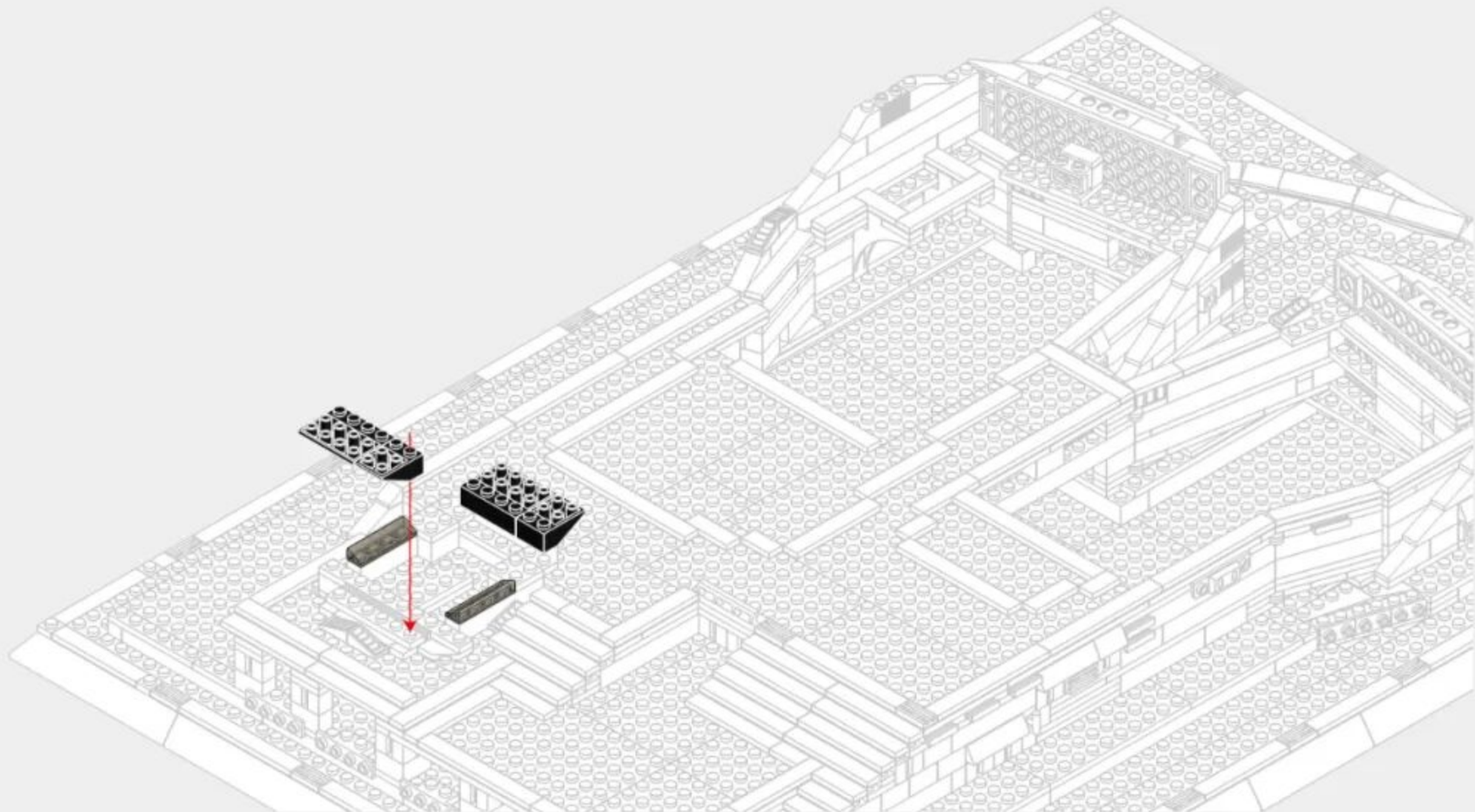

5-23

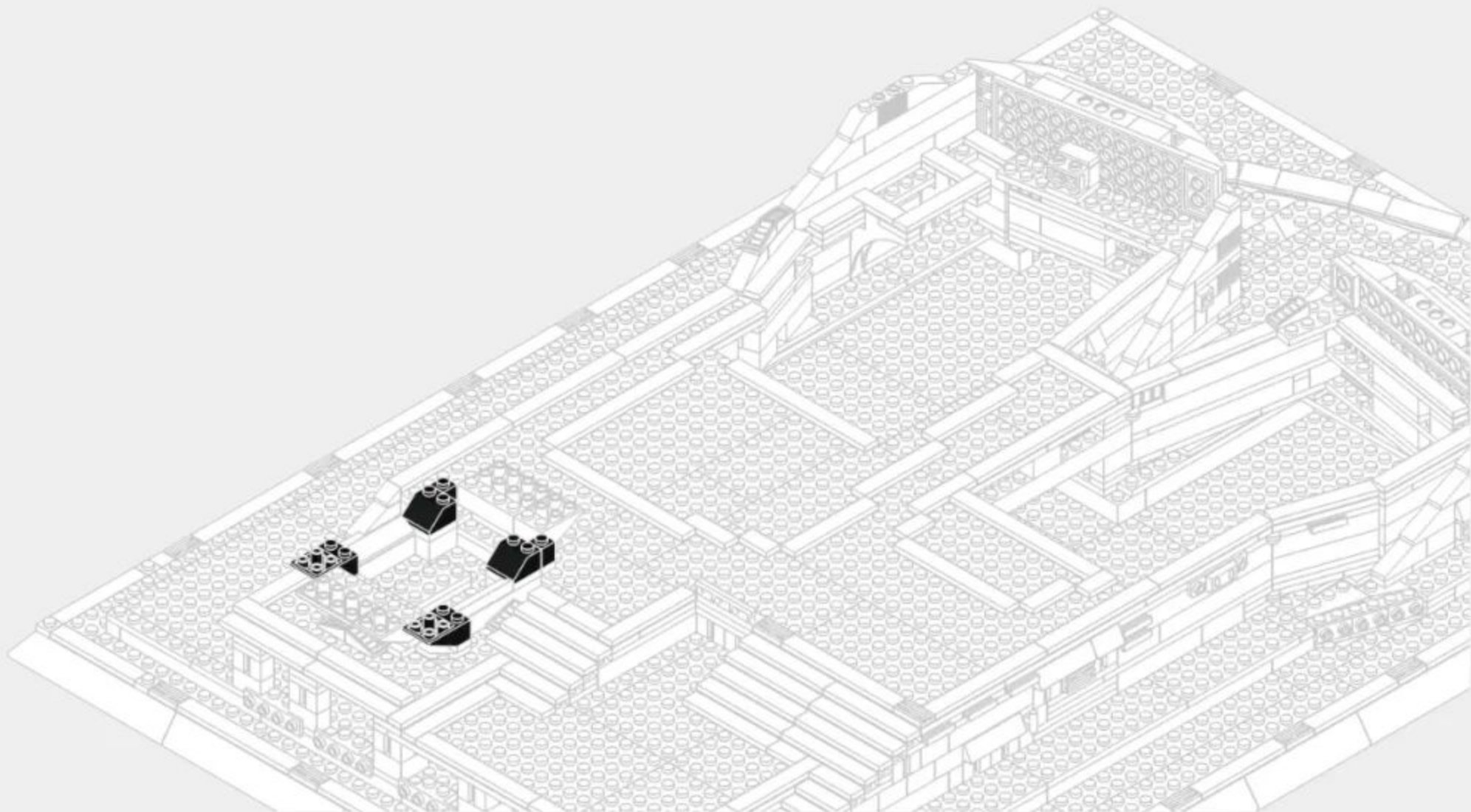

5-24

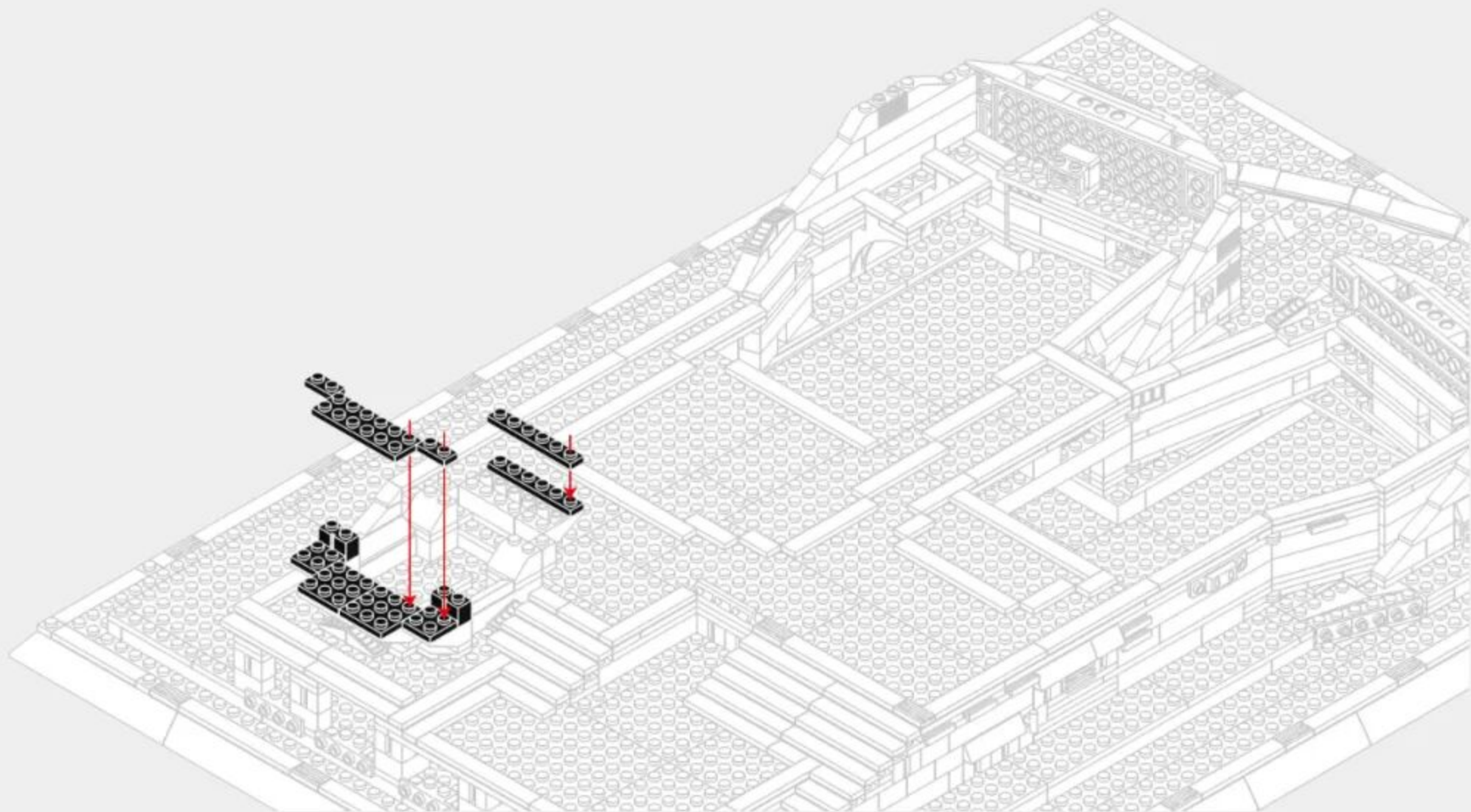

5-25

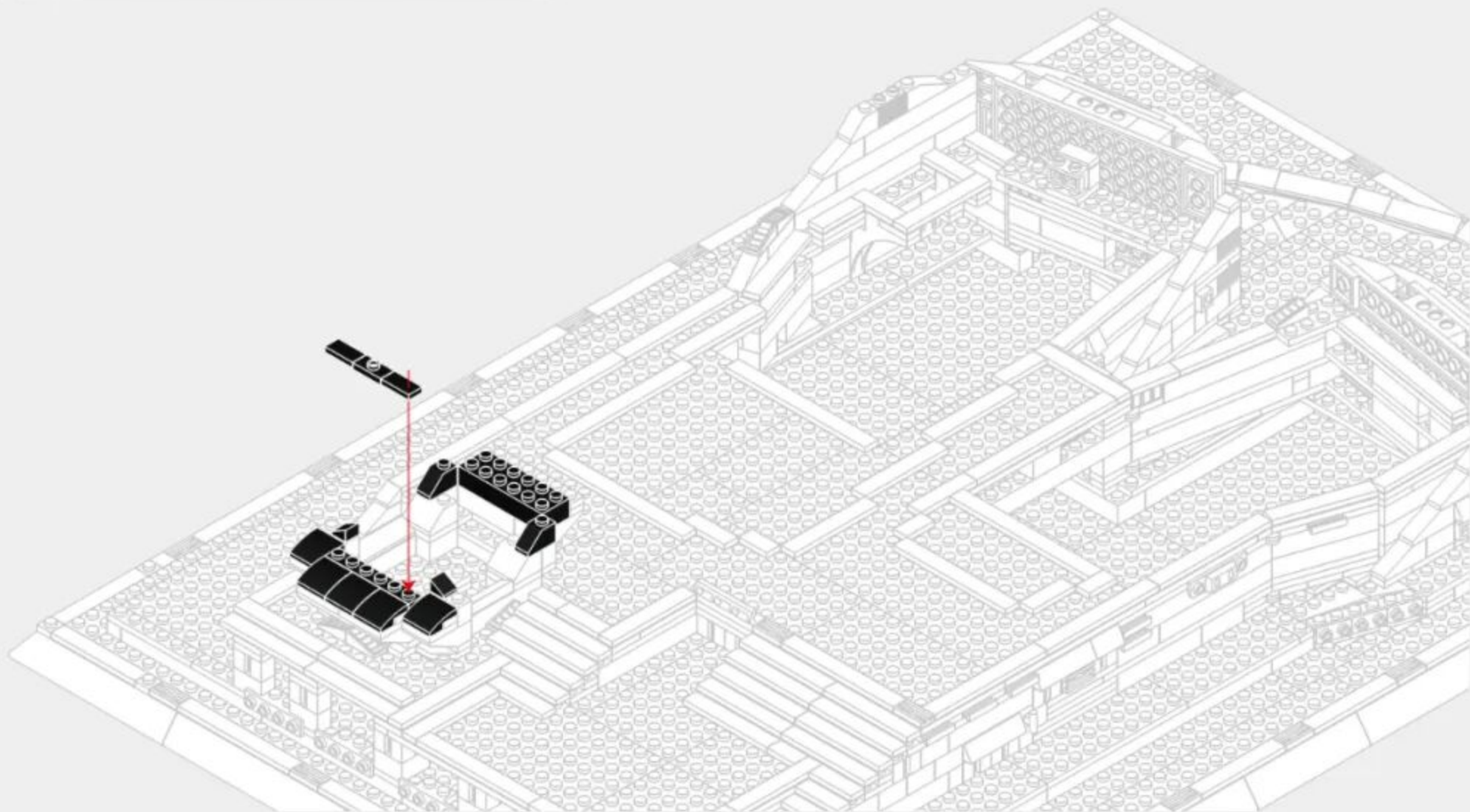

5-26

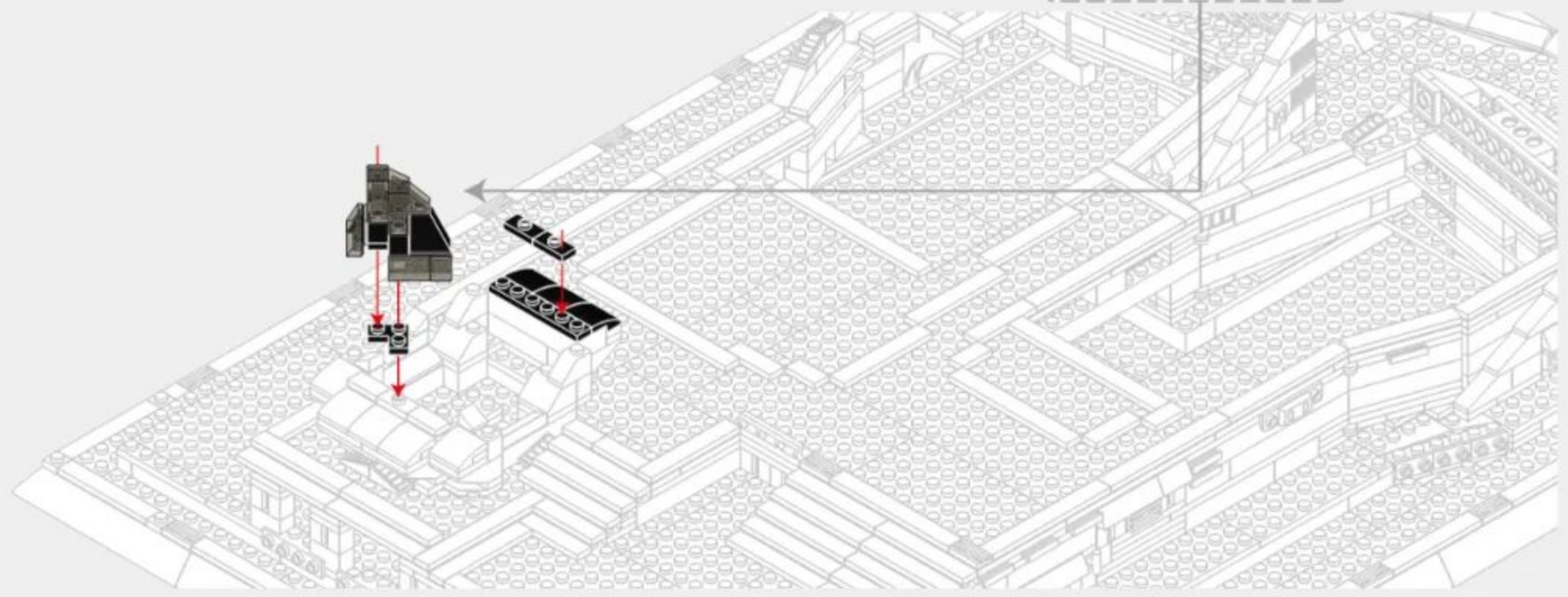

5-27

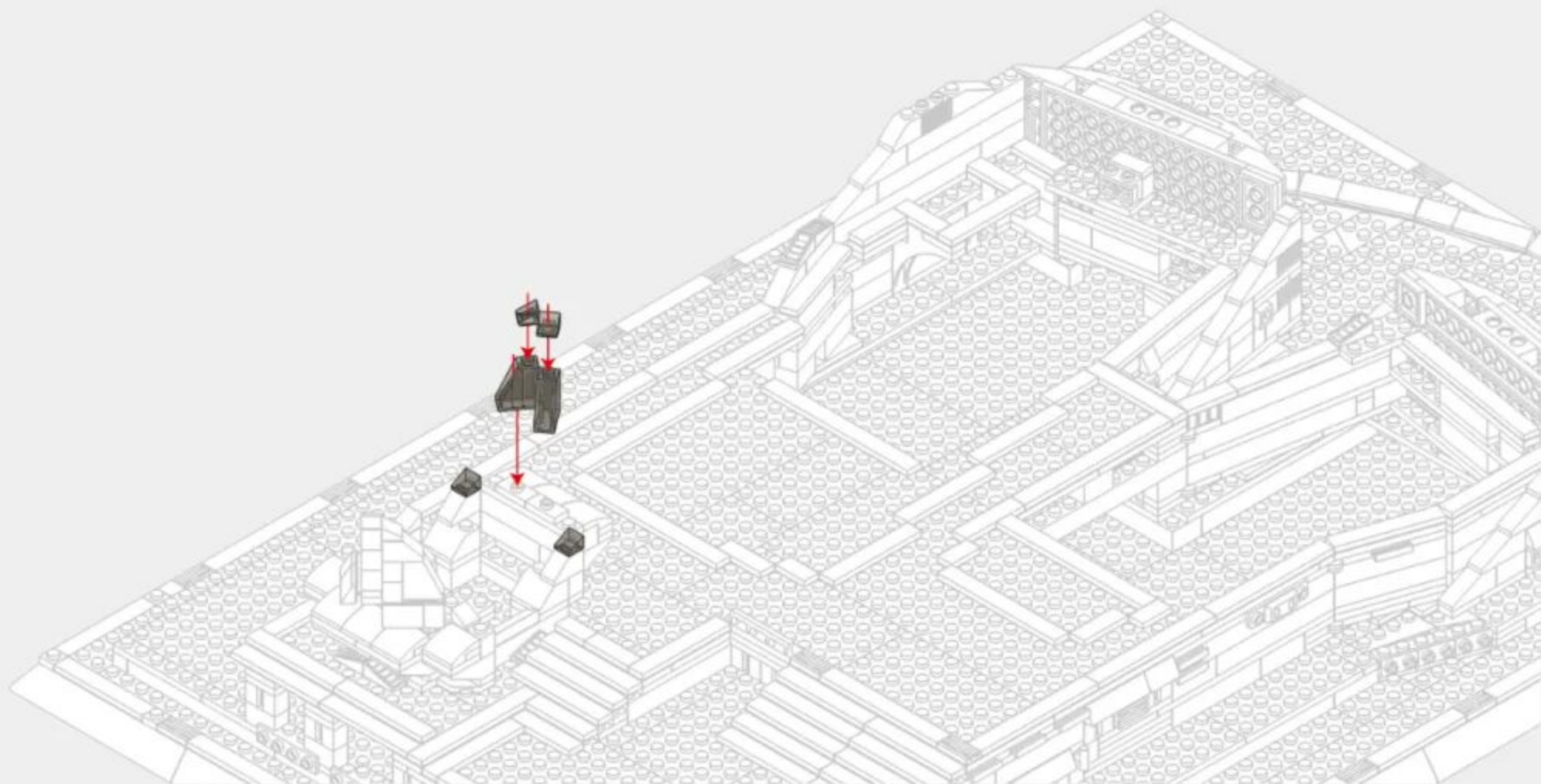

5-28

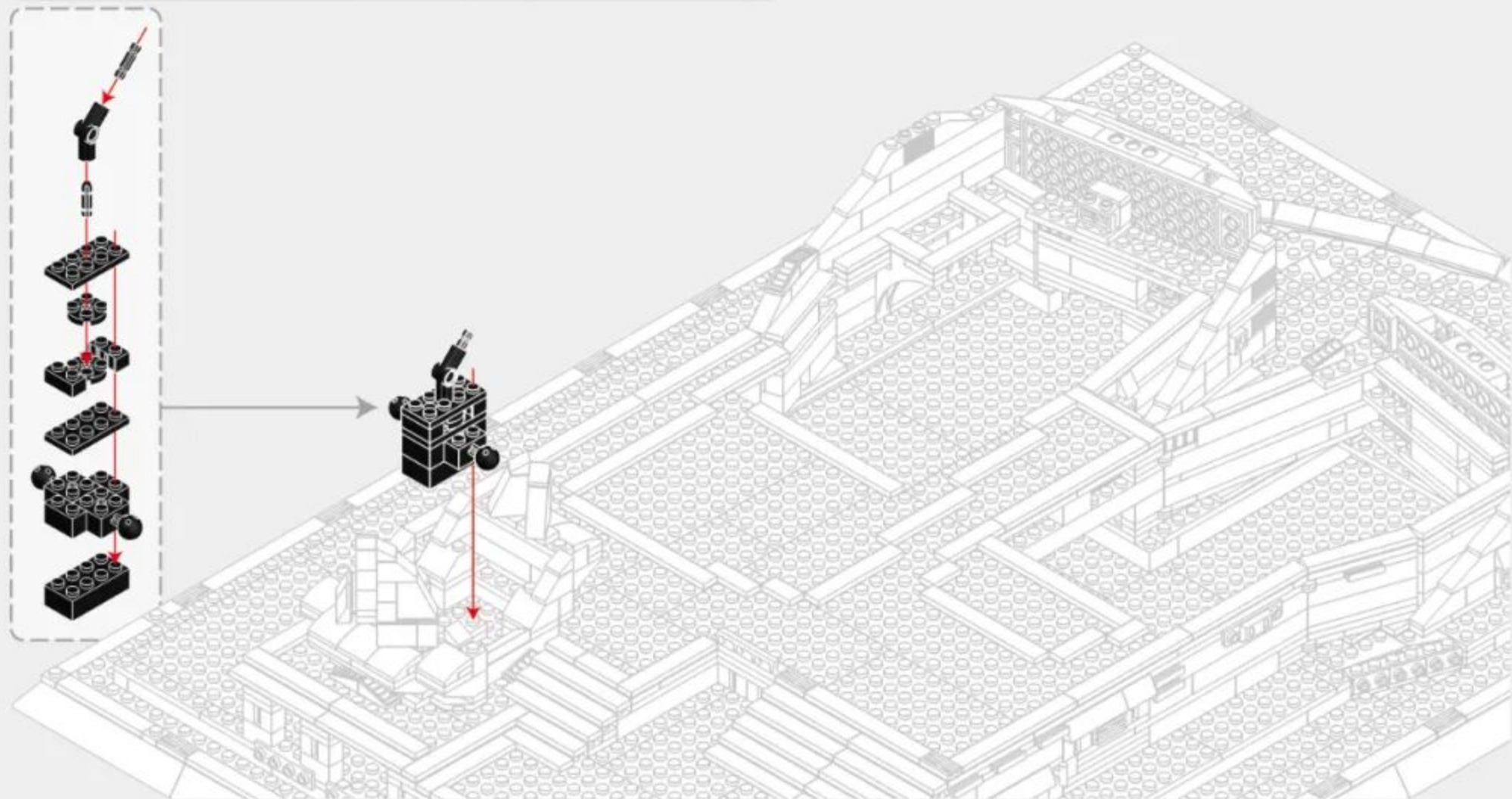

5-29

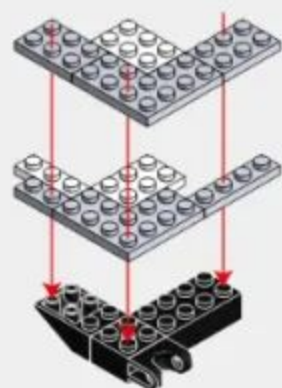
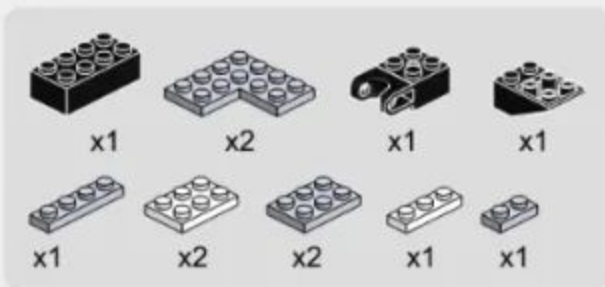

5-30

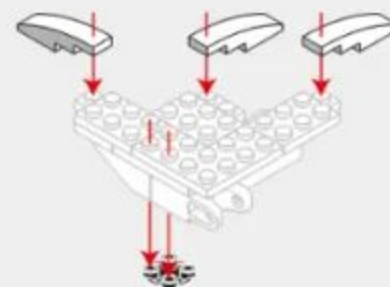

### 5-31

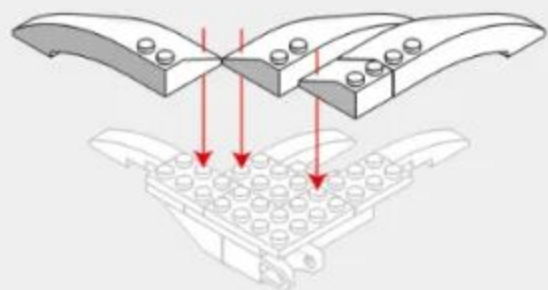
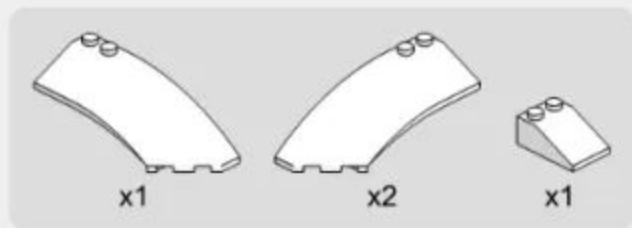

### 5-32

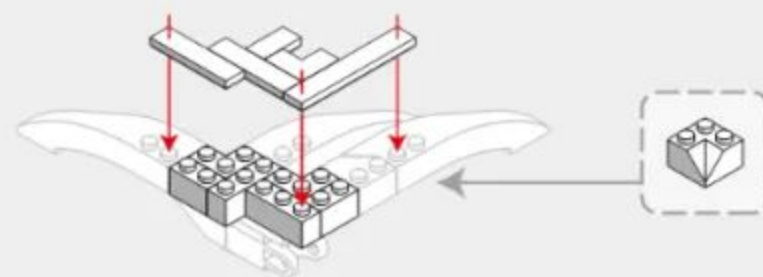
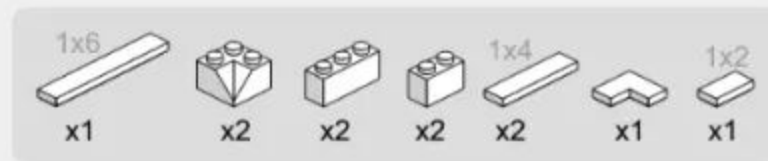

5-33

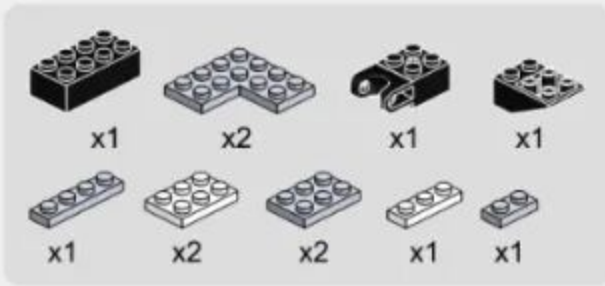

5-34

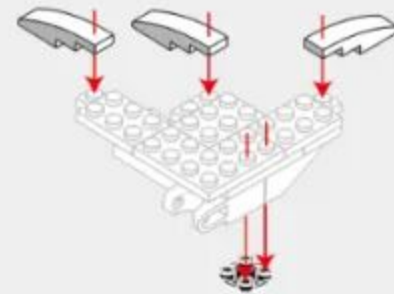
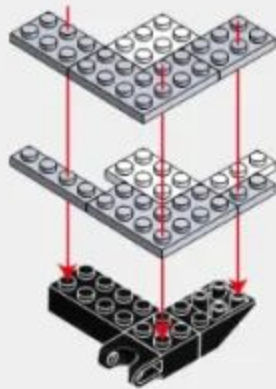

5-35

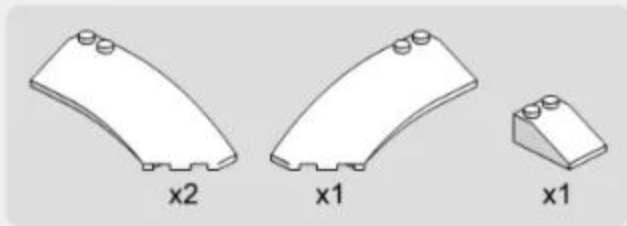

5-36

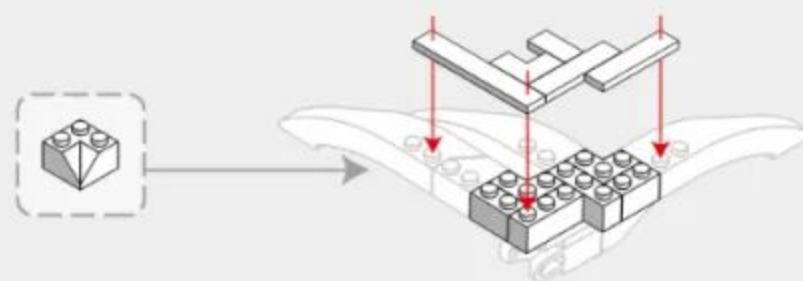
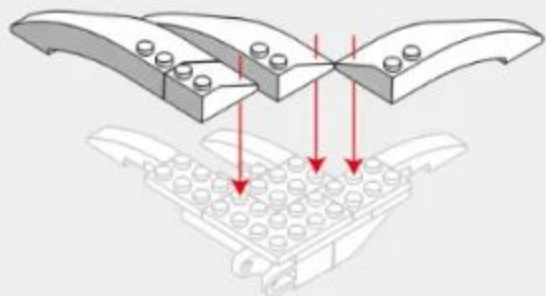
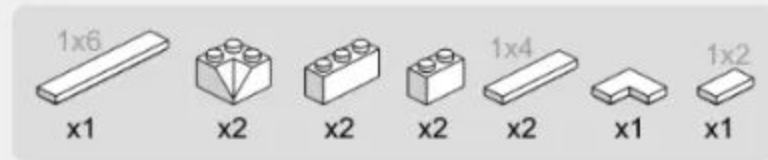

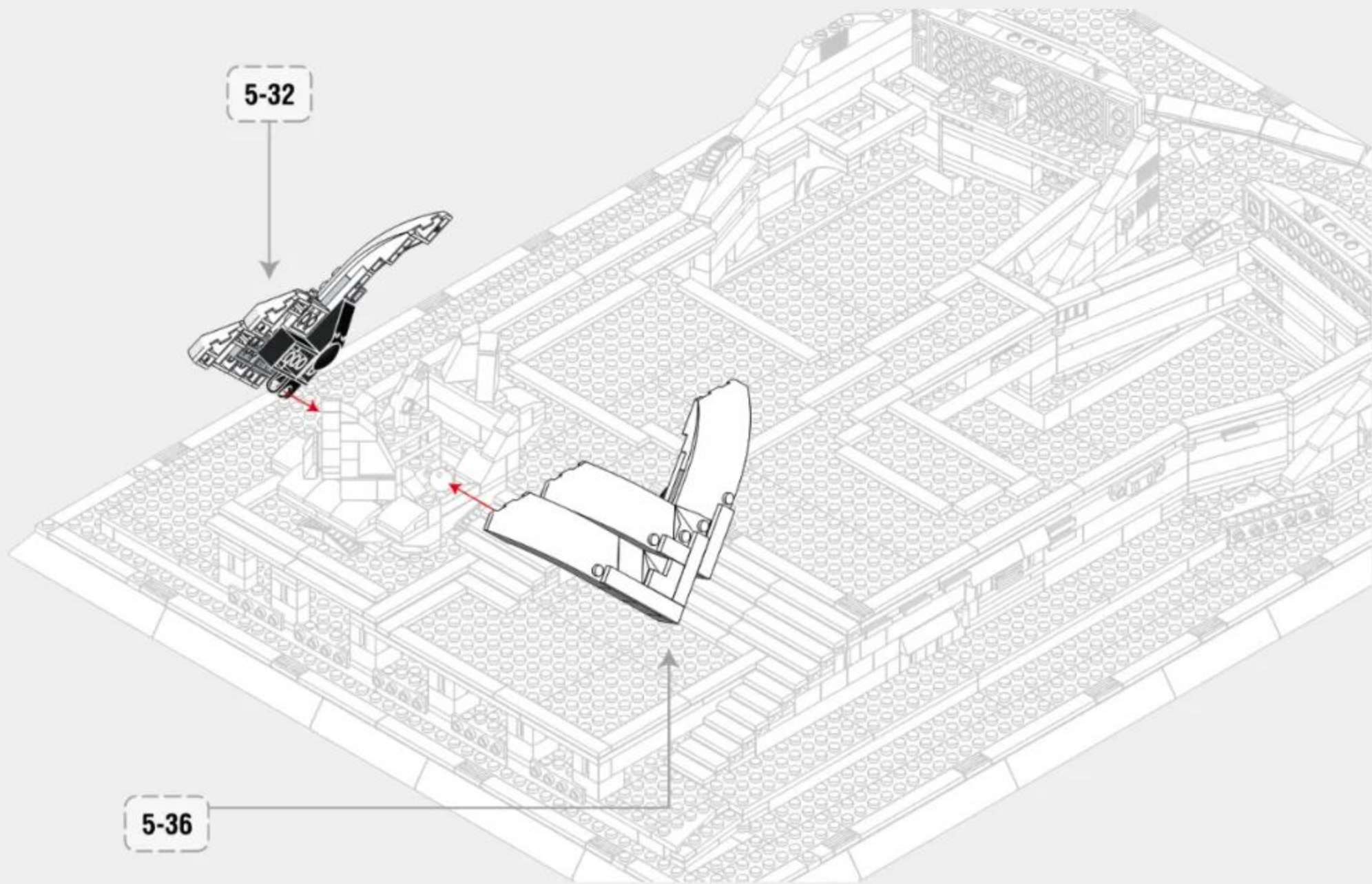

5-36

5-38

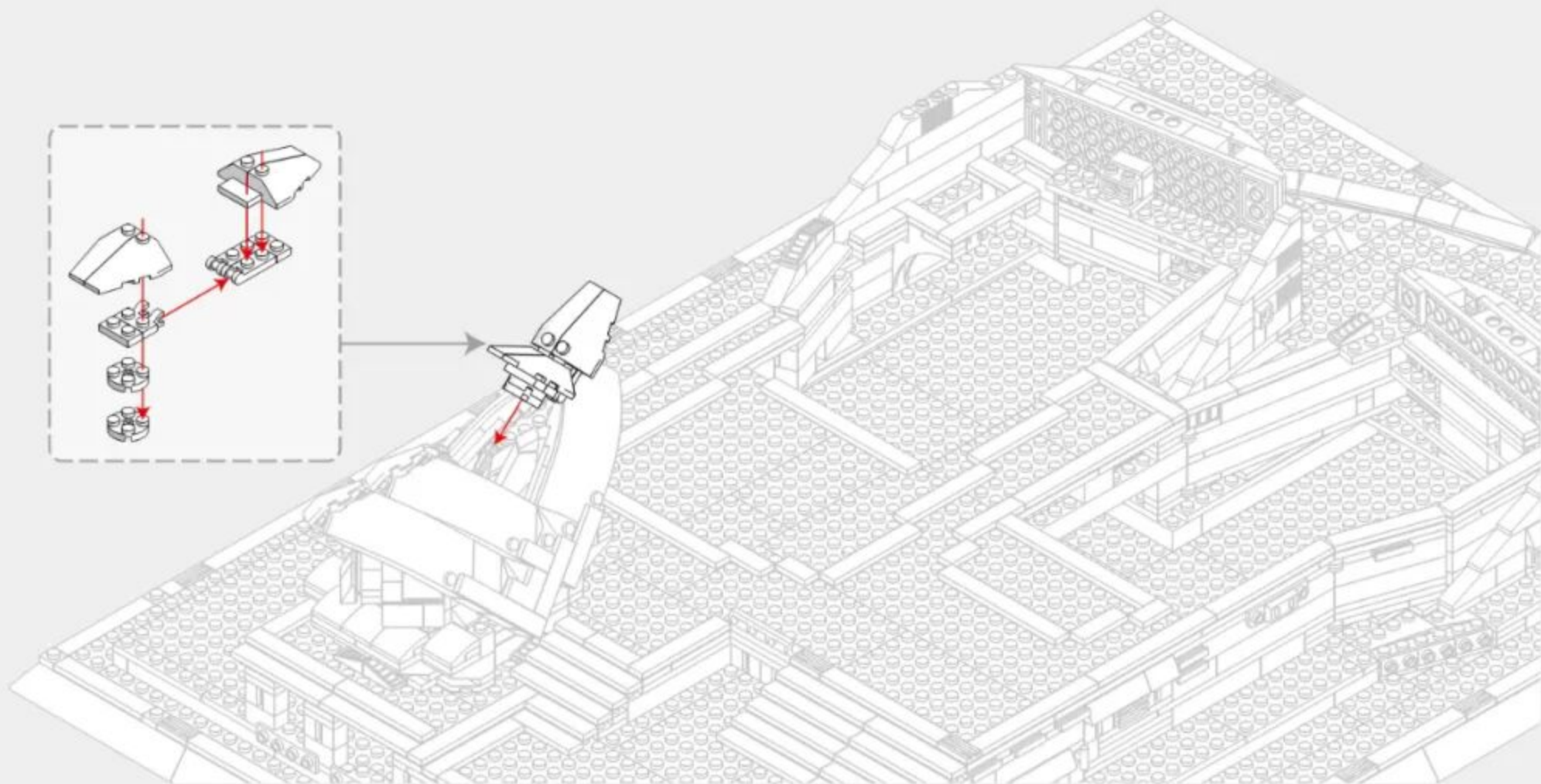



250PCS

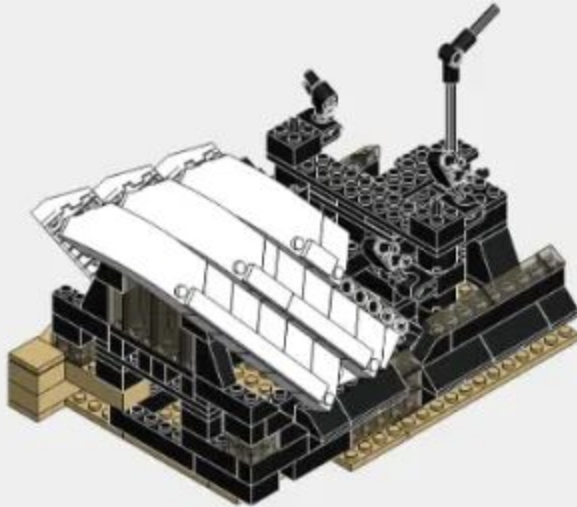

132

# 6-1

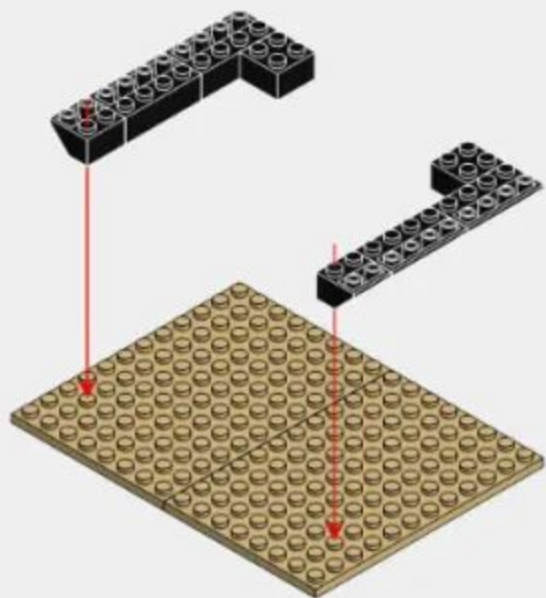
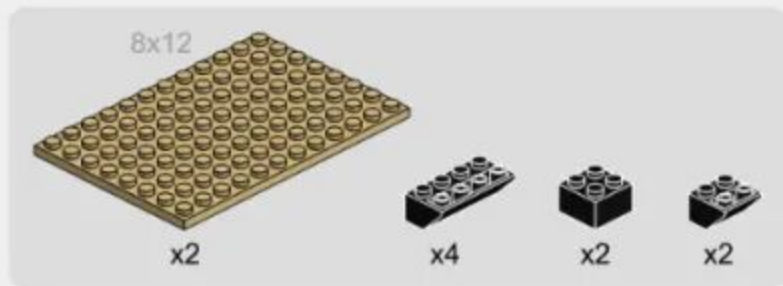

# 6-2

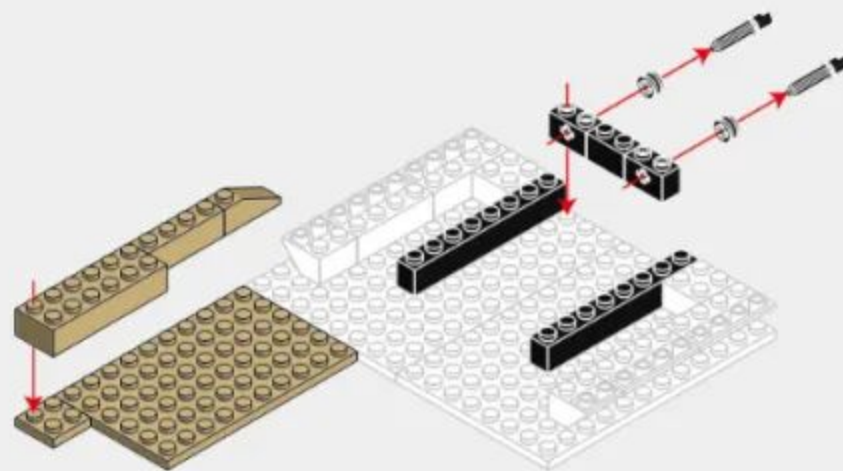
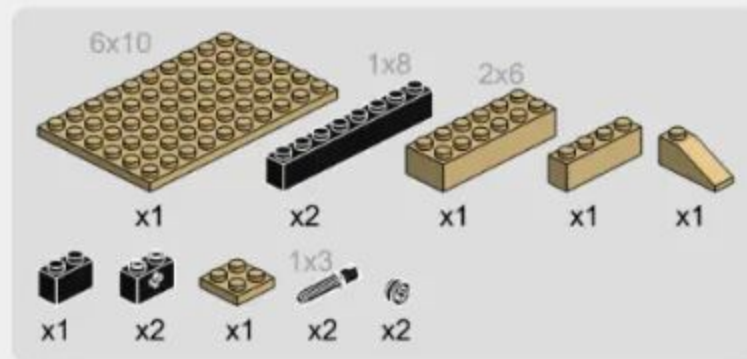

6-3

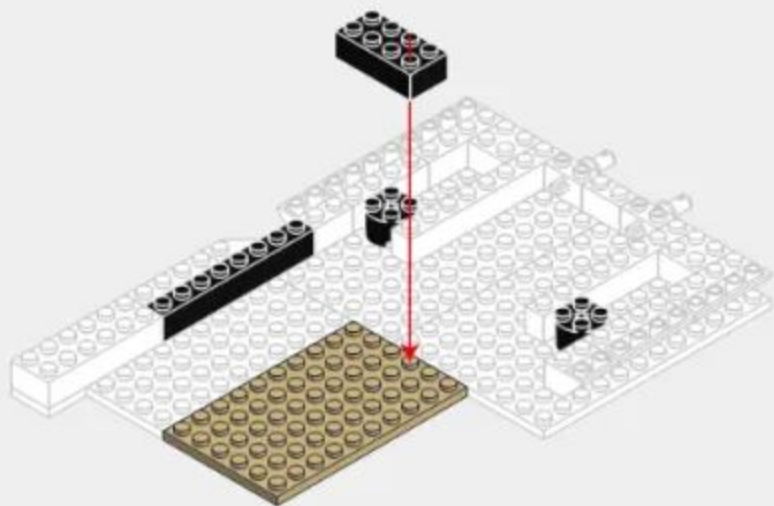
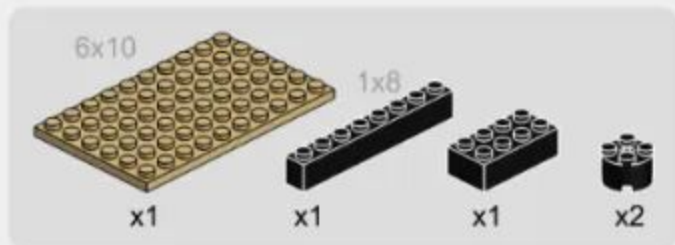

6-4

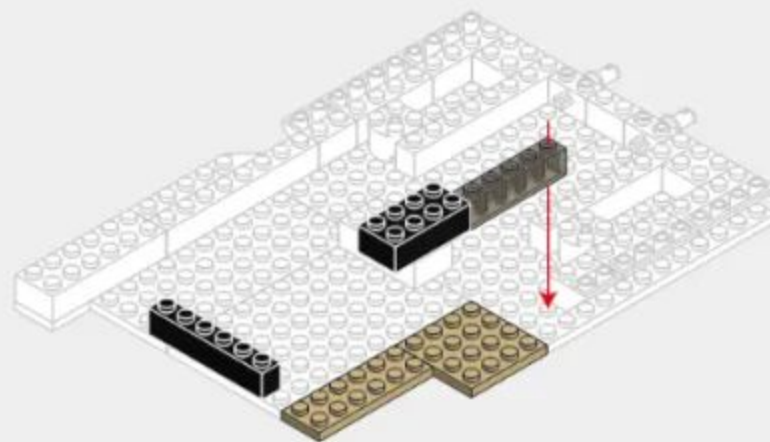

6-5

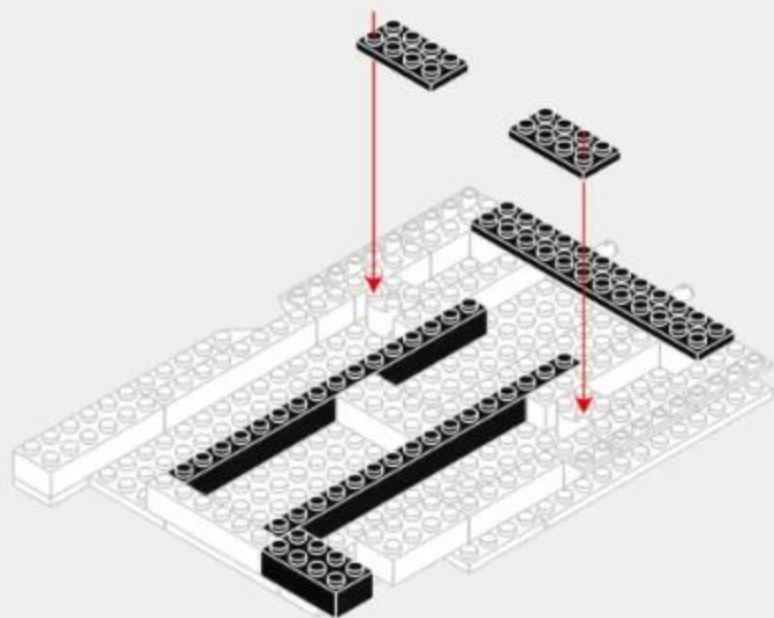
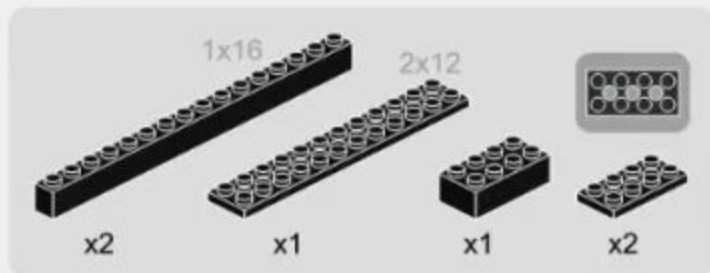

6-6

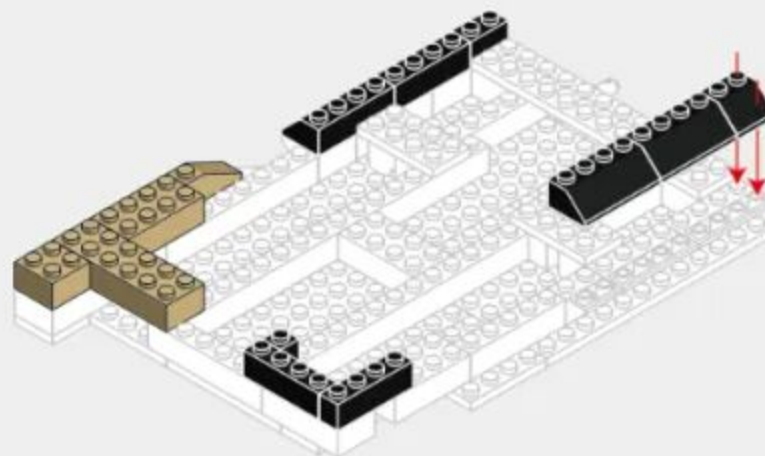
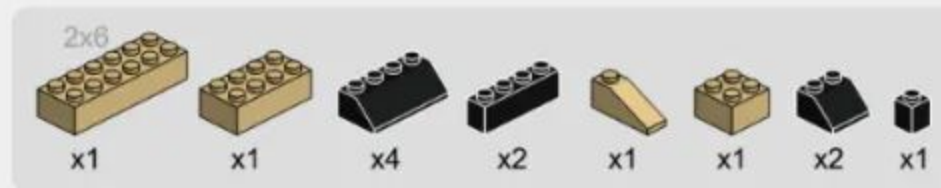

6-7

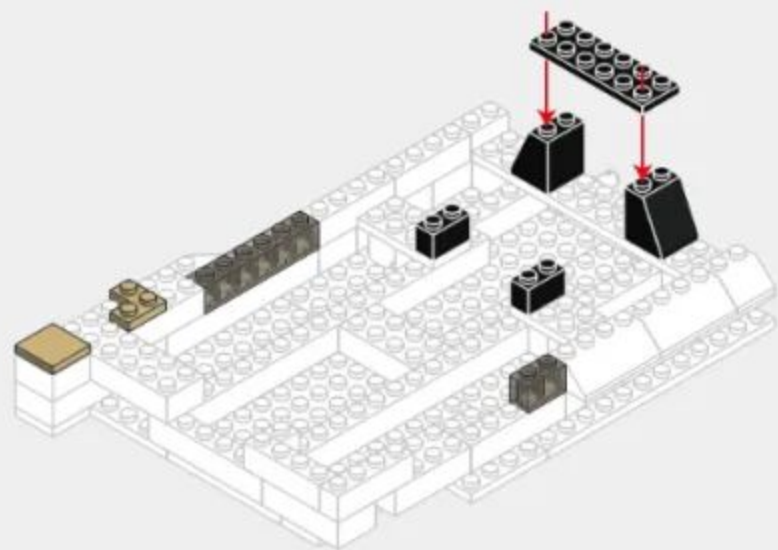

6-8

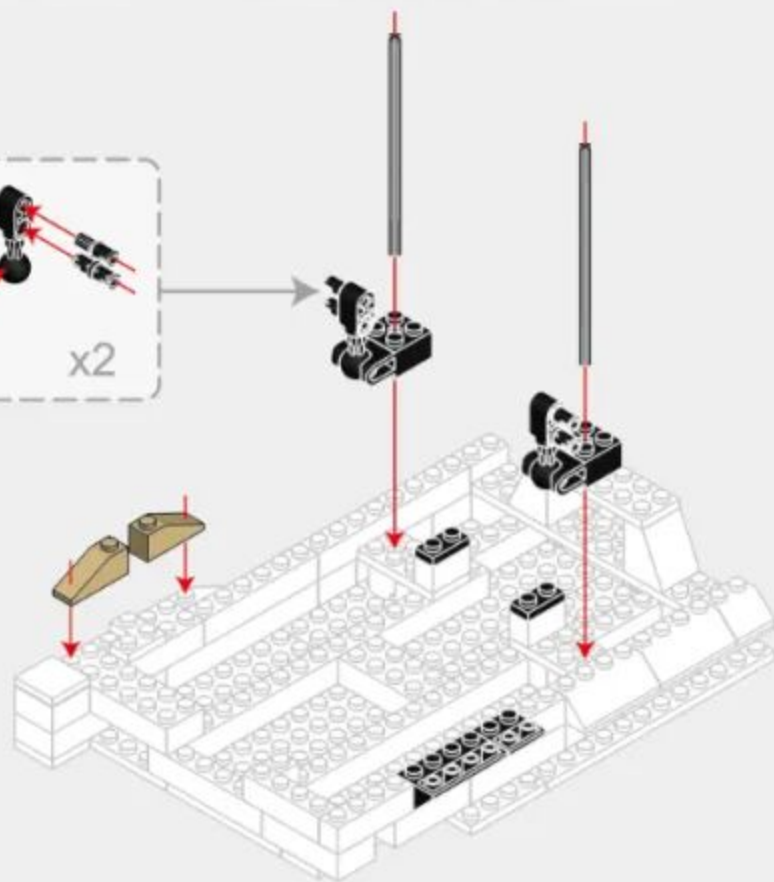
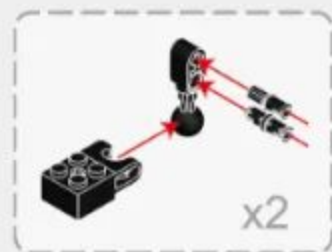

6-9

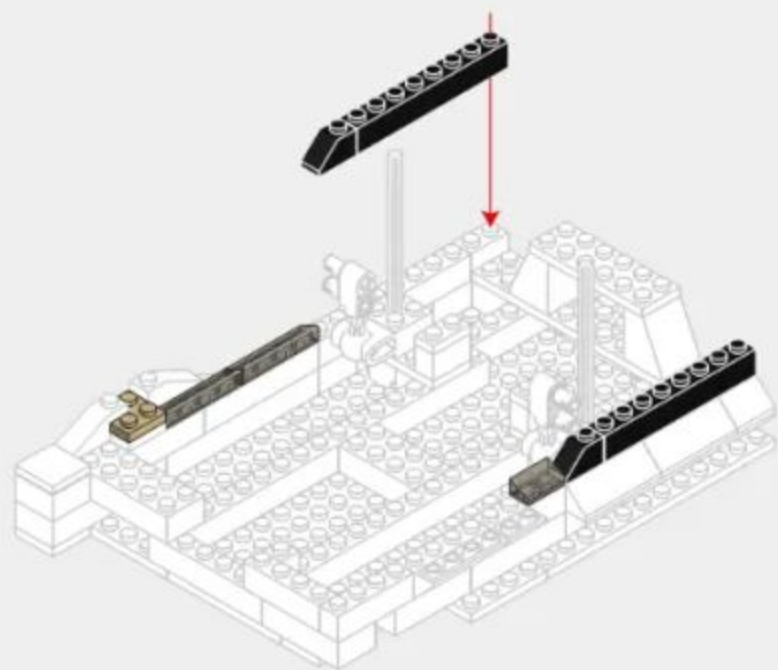

6-10

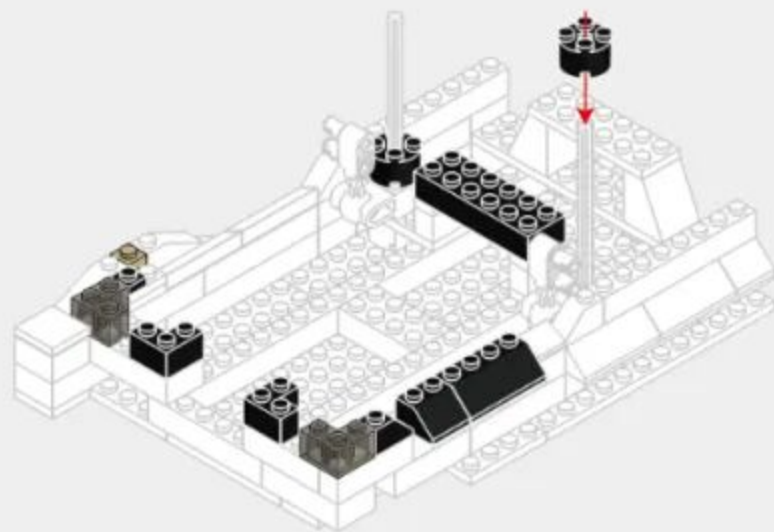

### 6-11

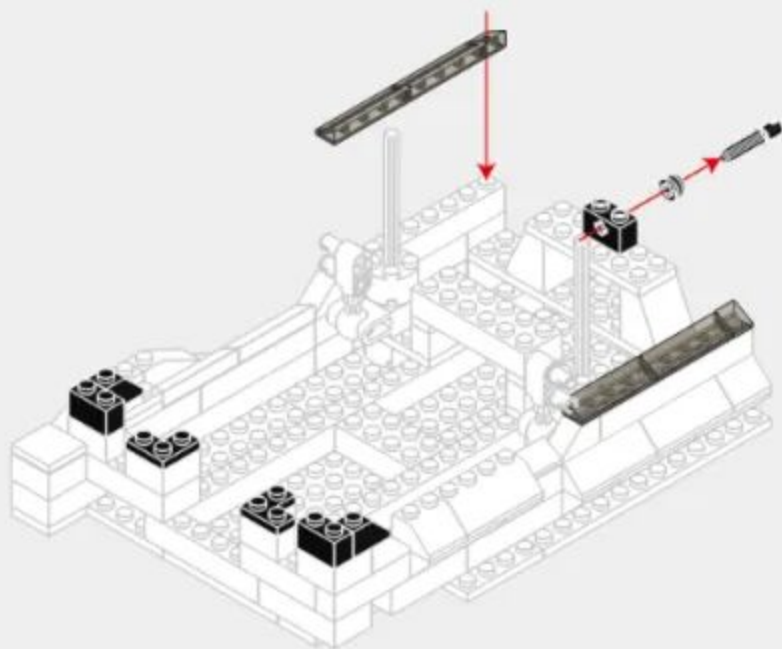

### 6-12

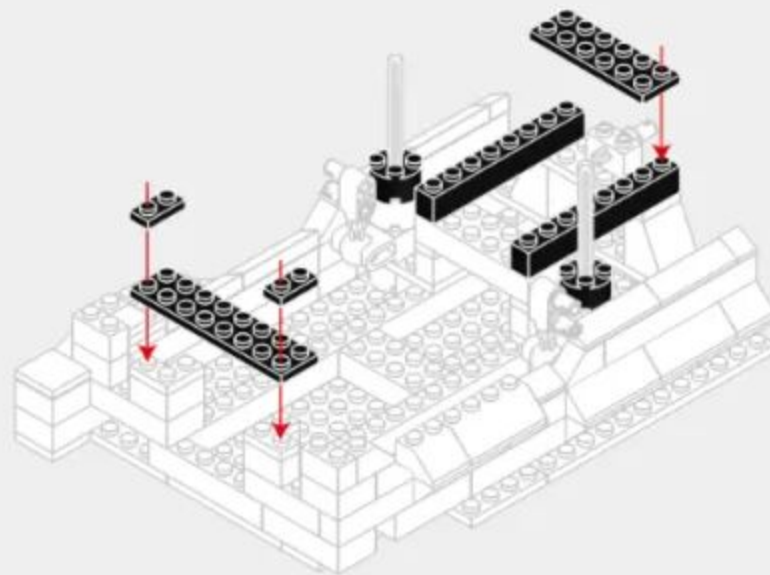
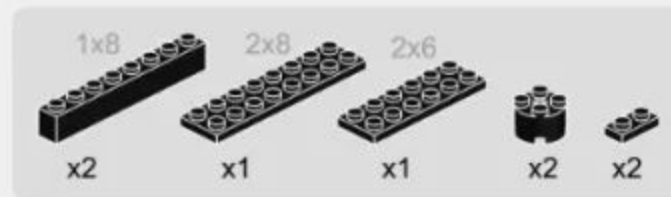

6-13

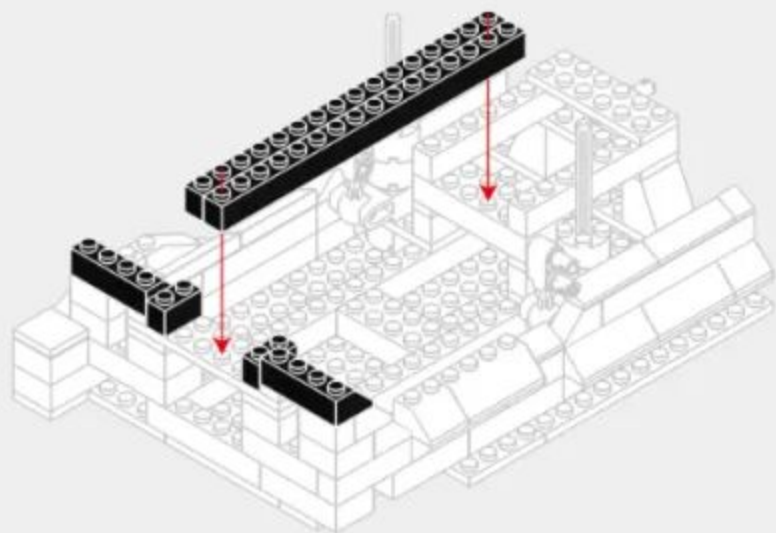
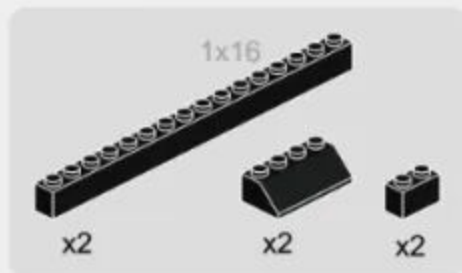

6-14

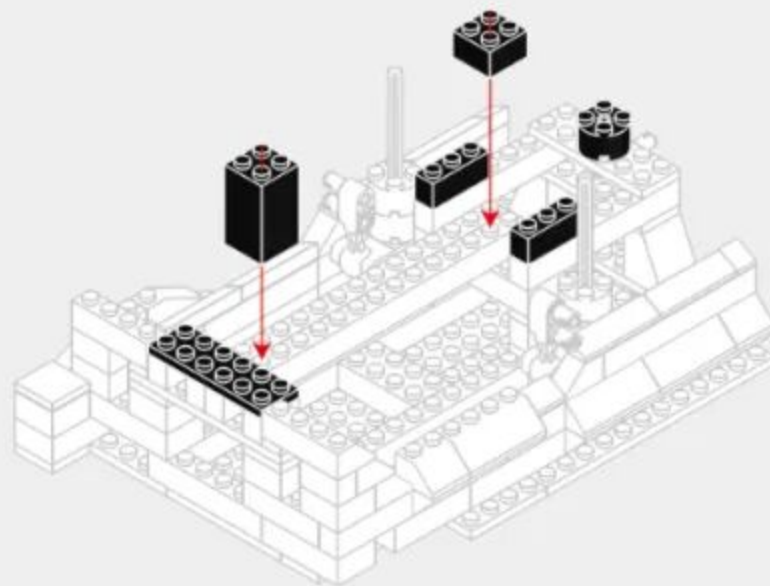
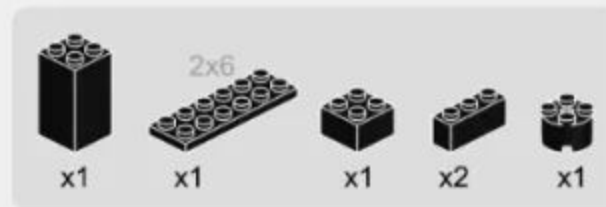

# 6-15

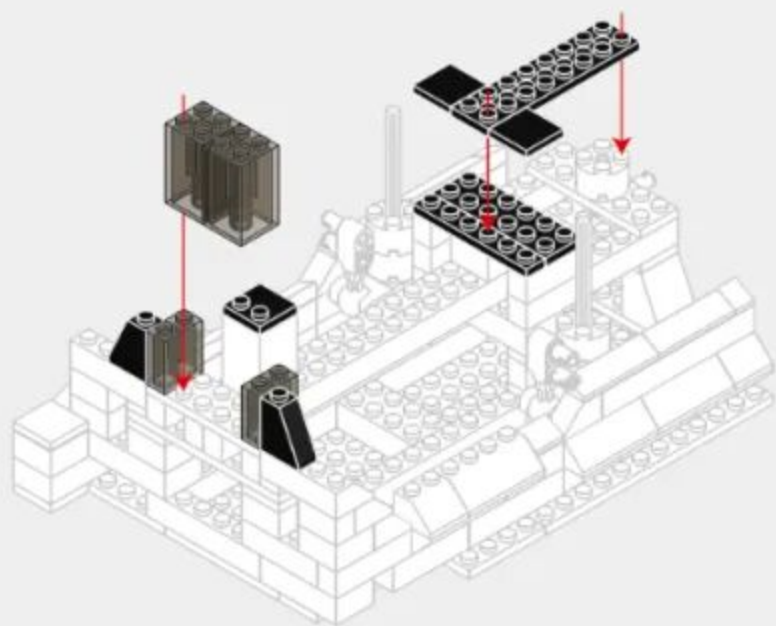
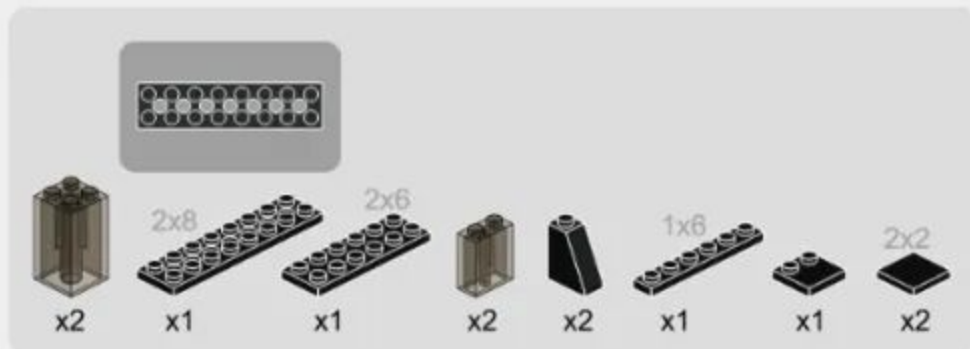

# 6-16

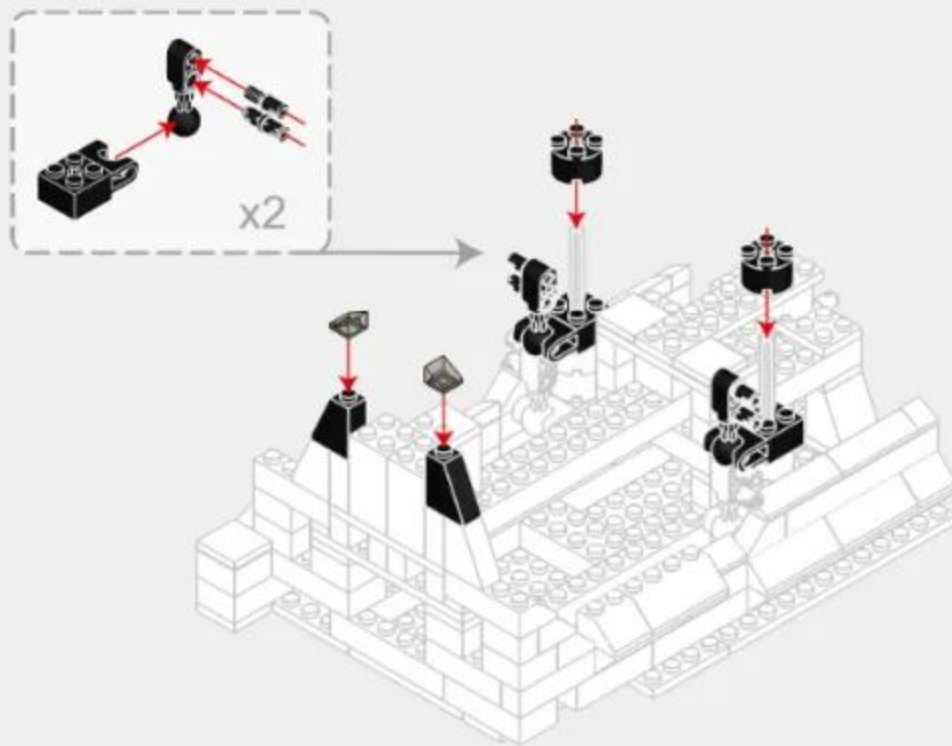

# 6-17

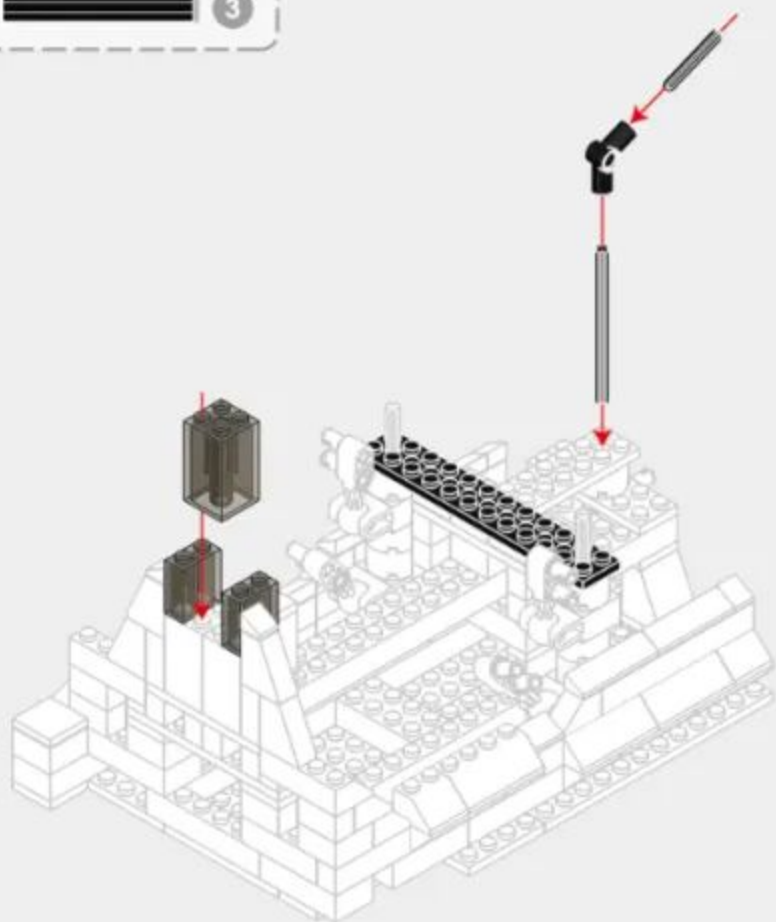

# 6-18

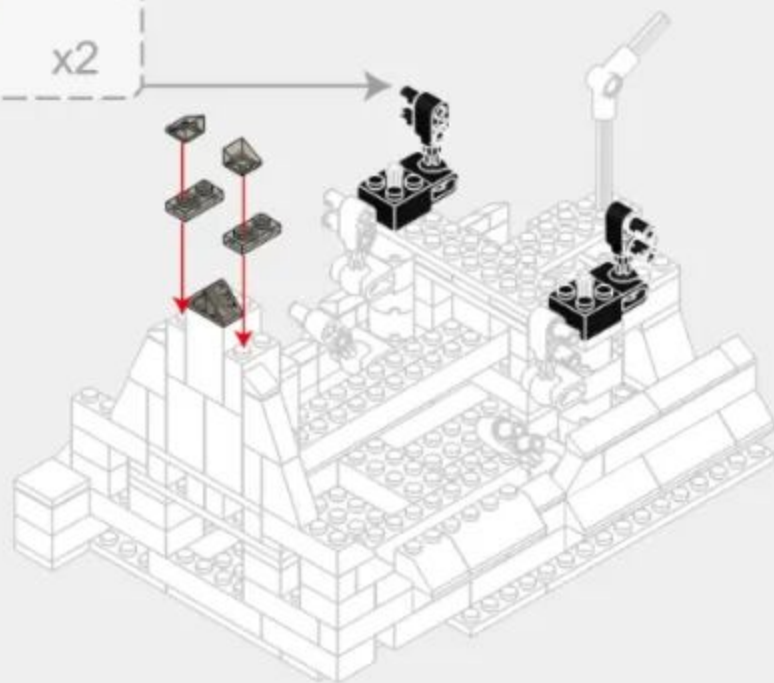

# 6-19

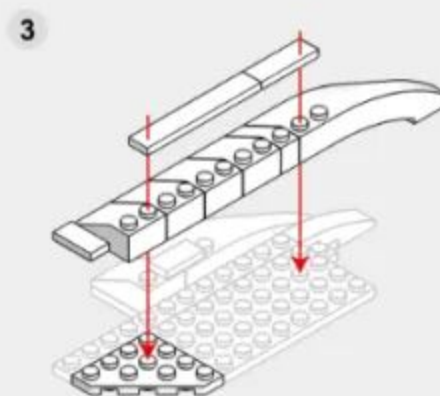
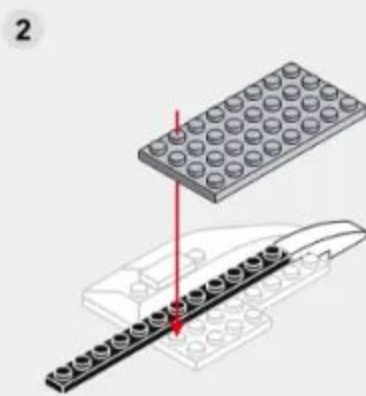
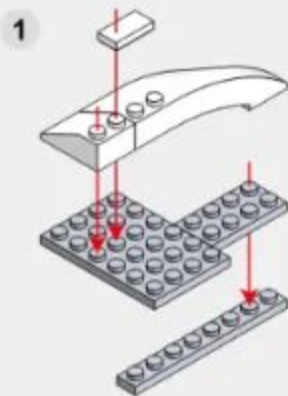
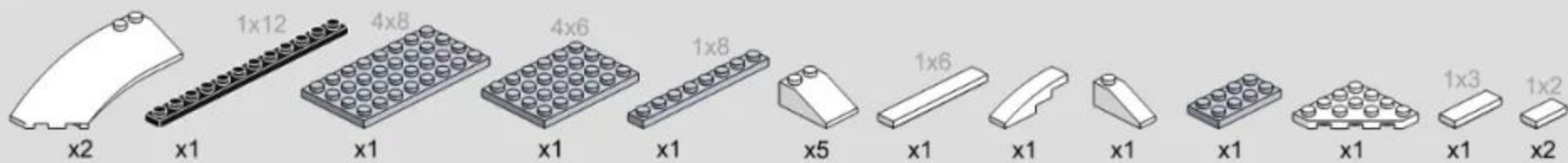

# 6-20

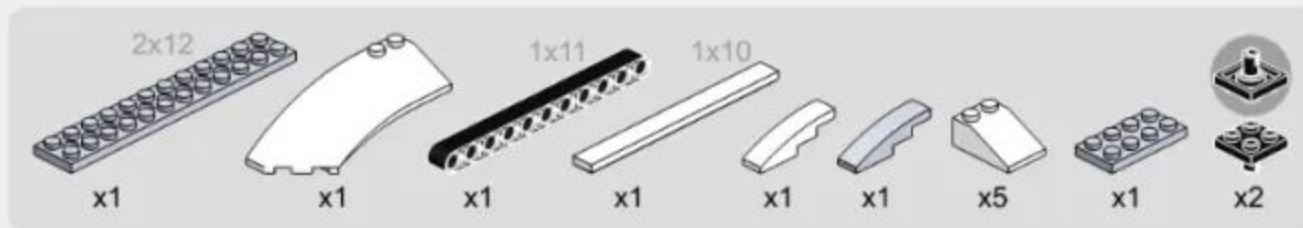

4

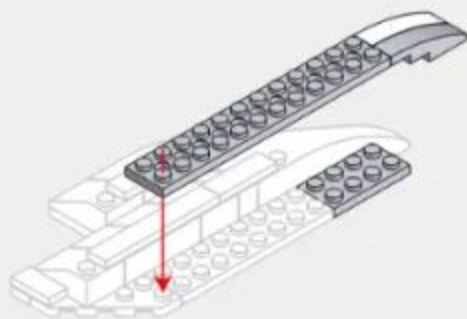

5

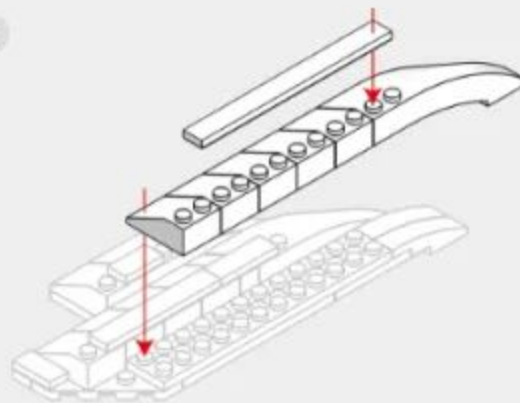

6

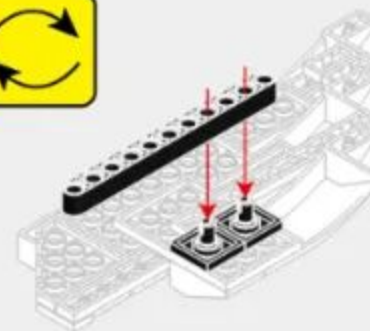

# 6-21

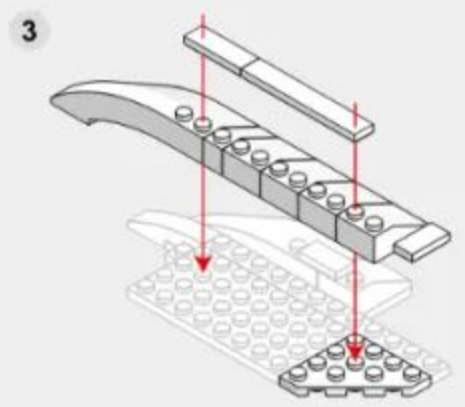
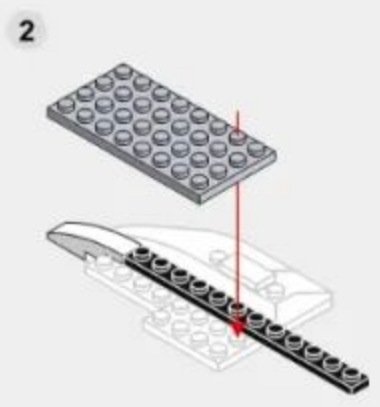
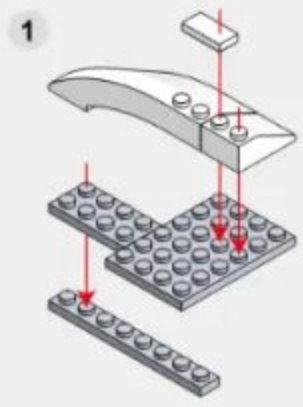
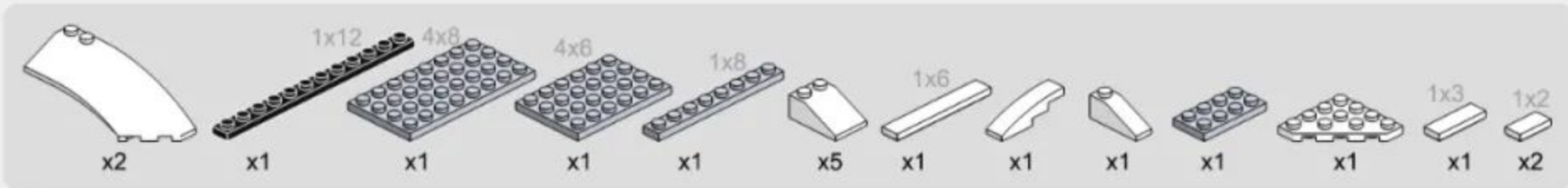

# 6-22

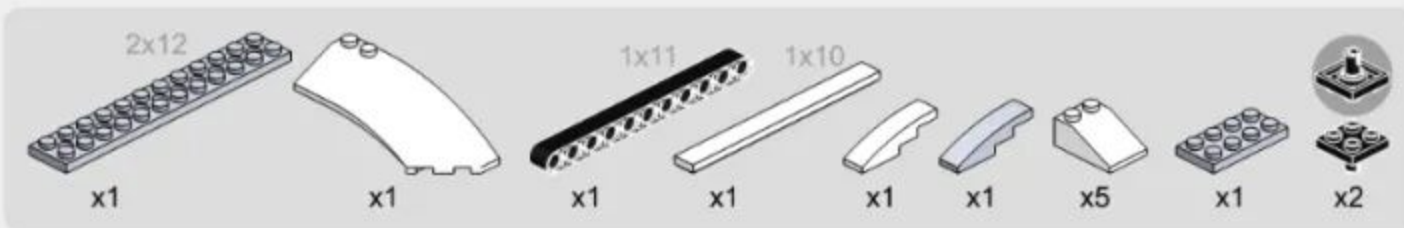

4

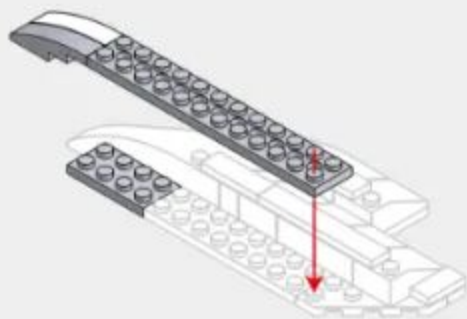

5

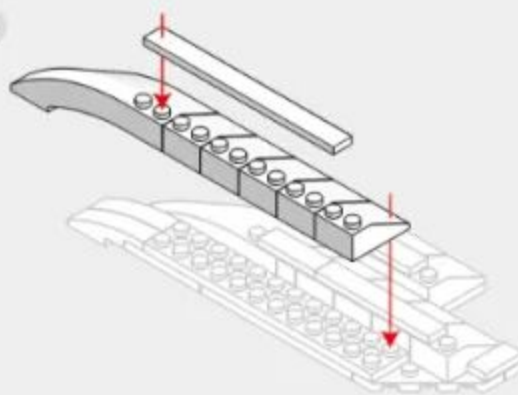

6

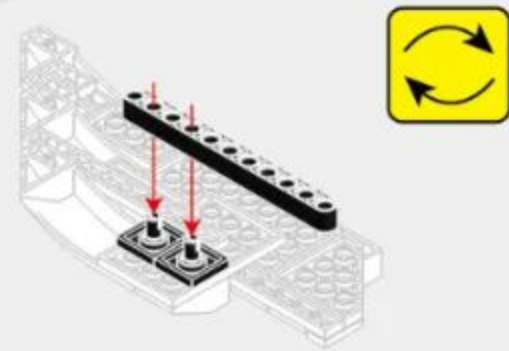

6-23



6-20

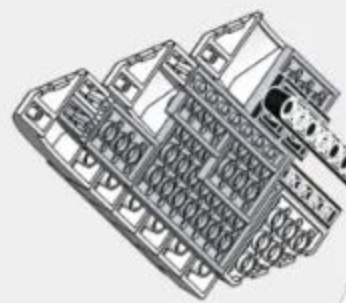

6-18

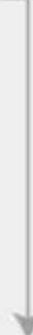

6-24

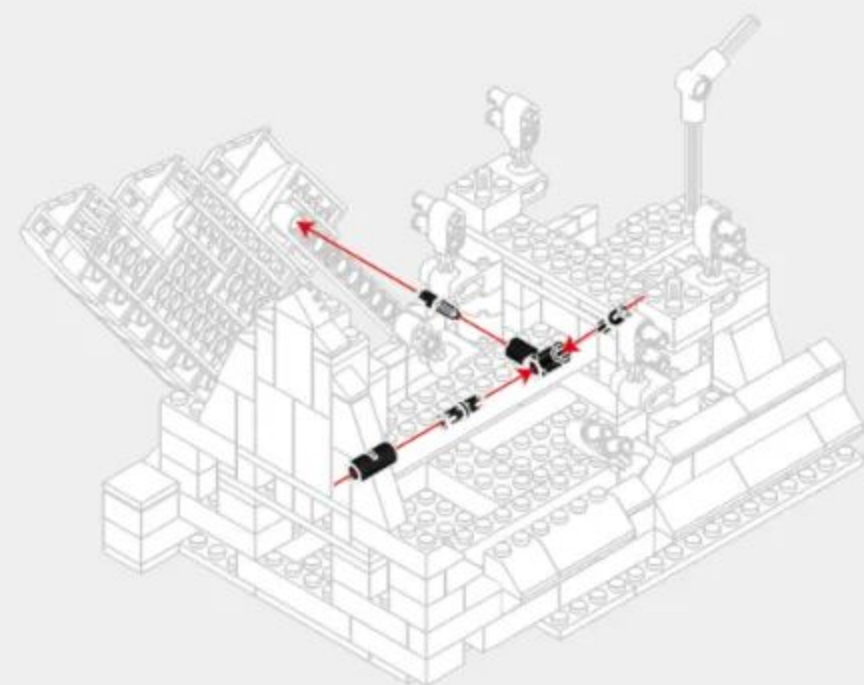

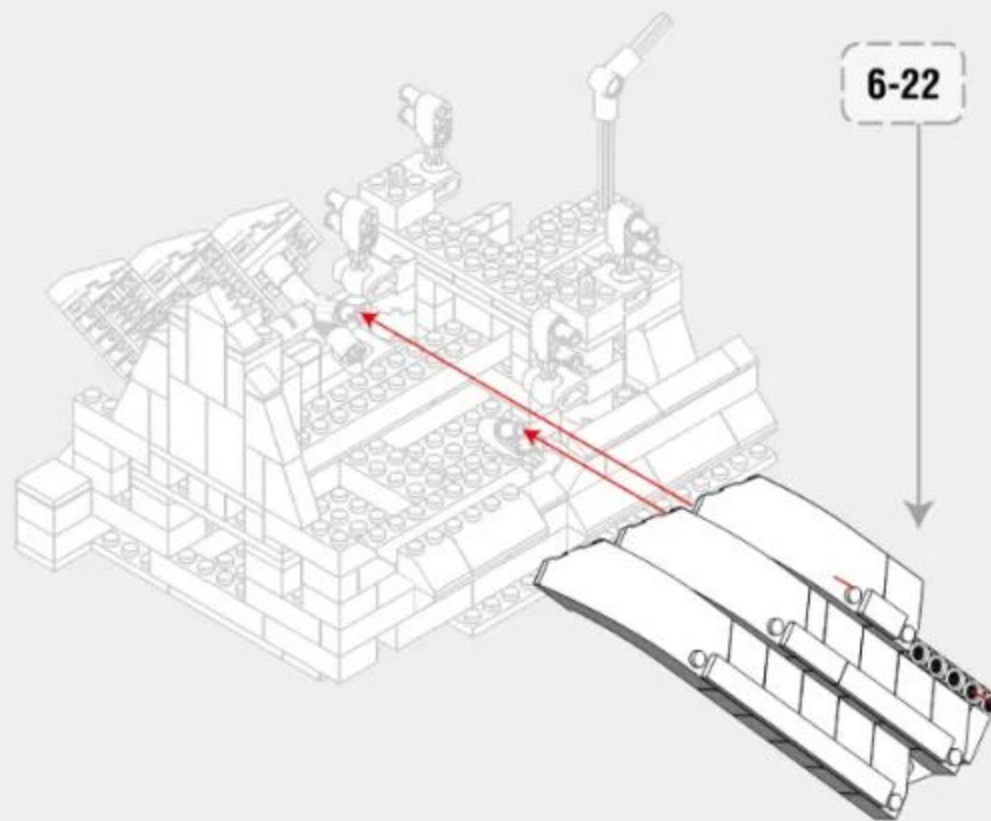



236PCS

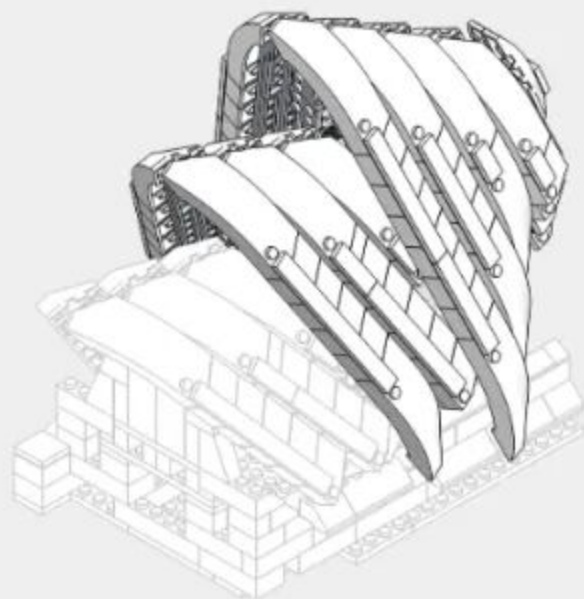

# 7-1

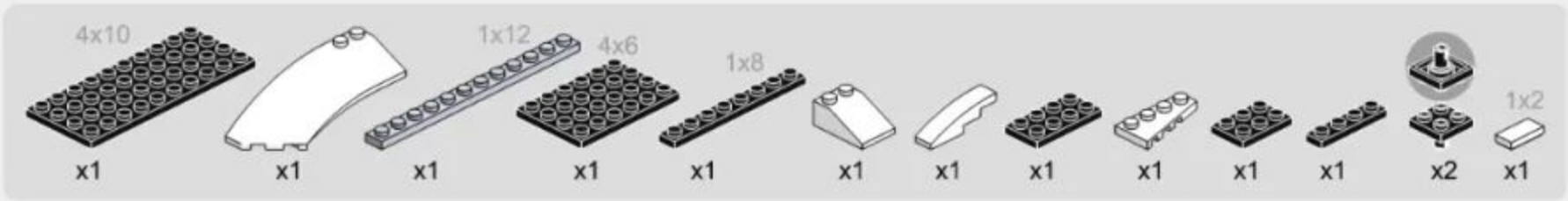

1

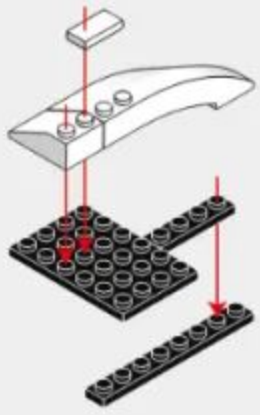

2

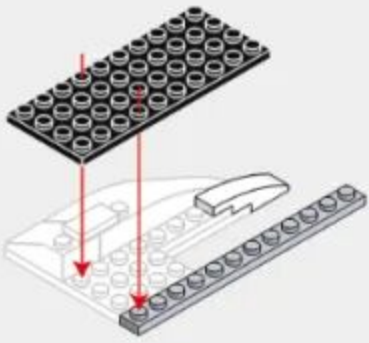

3

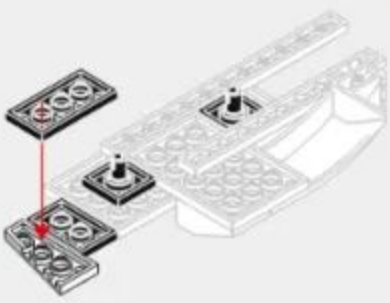

# 7-2

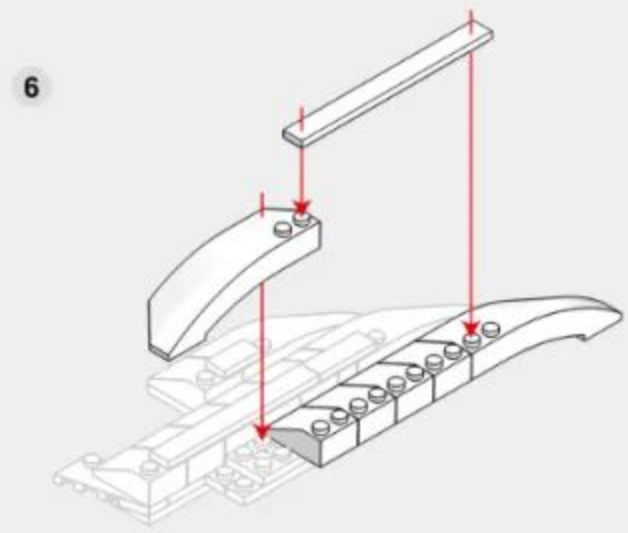
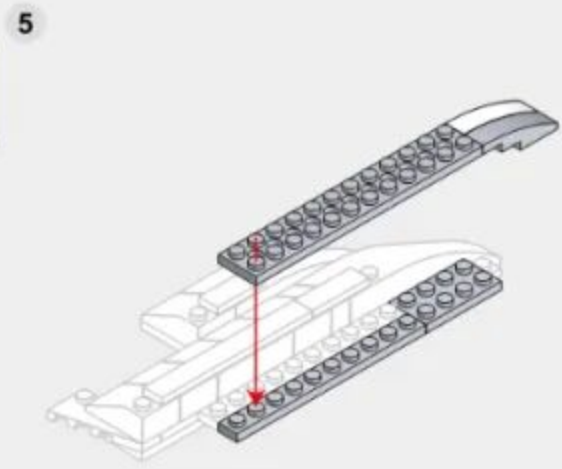
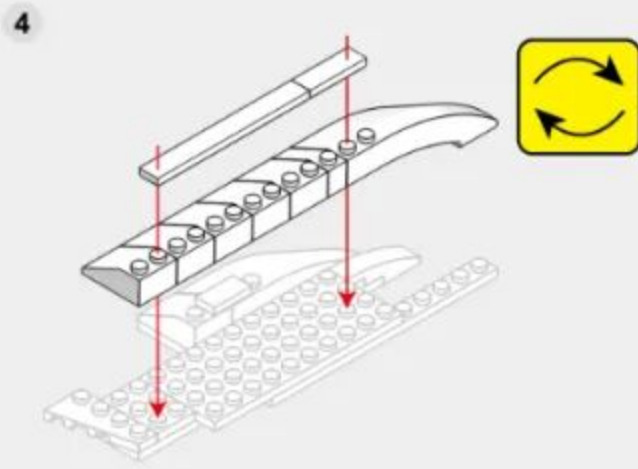
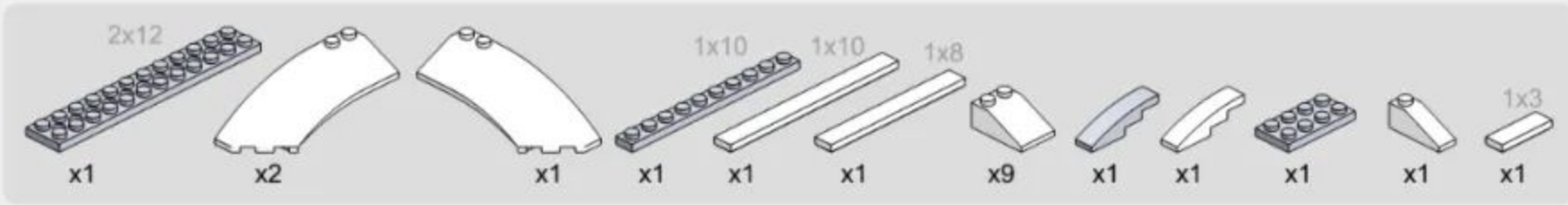

7-3

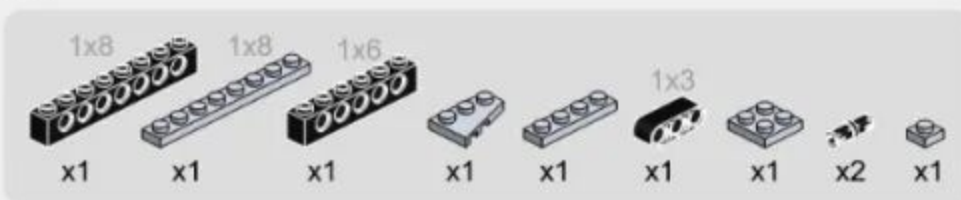

7

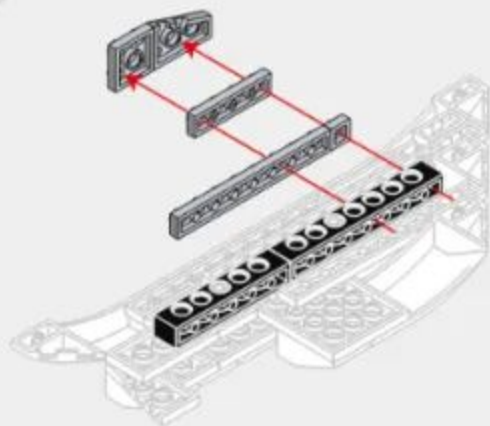

8

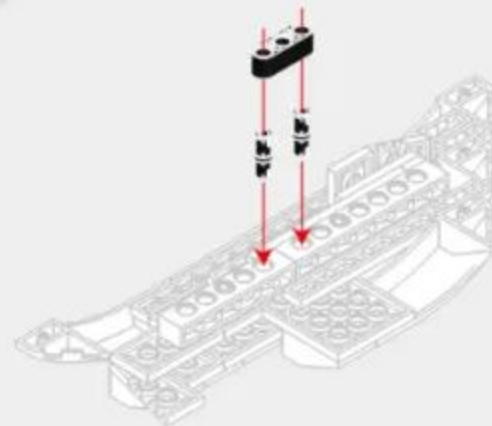

# 7-4

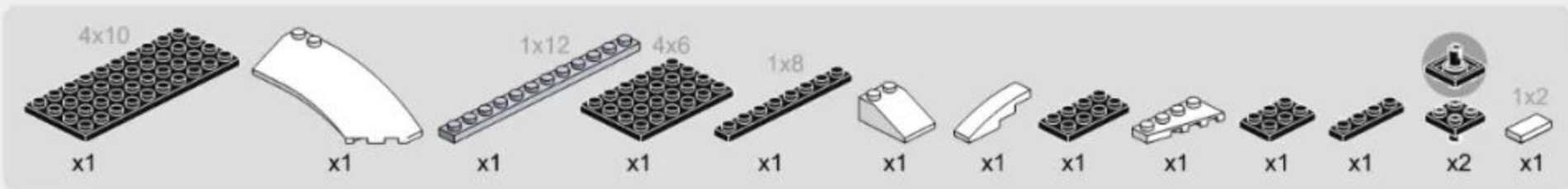

1

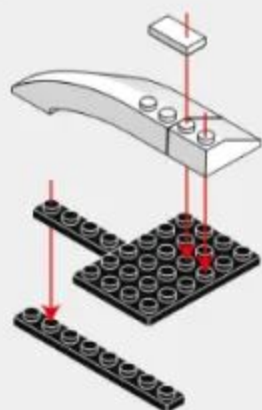

2

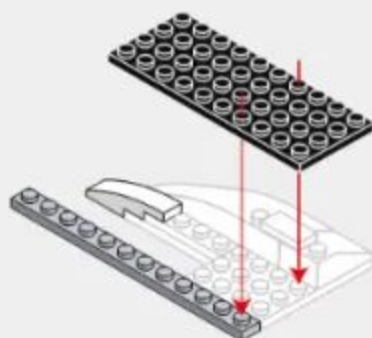

3

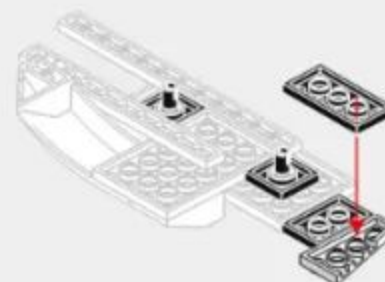

# 7-5

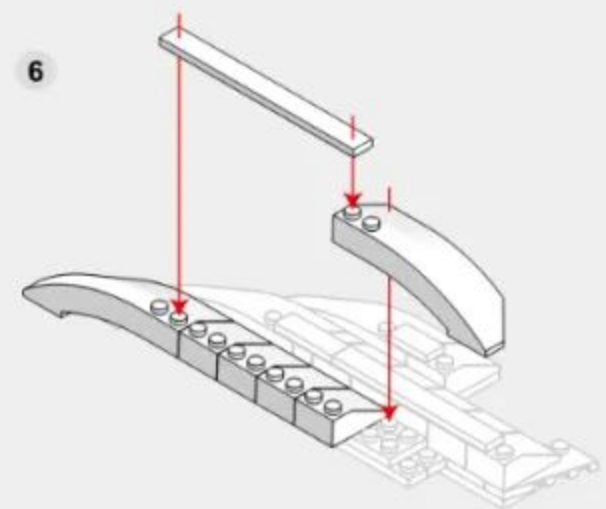
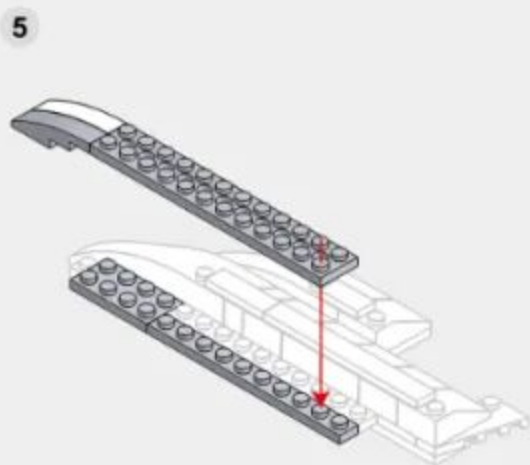
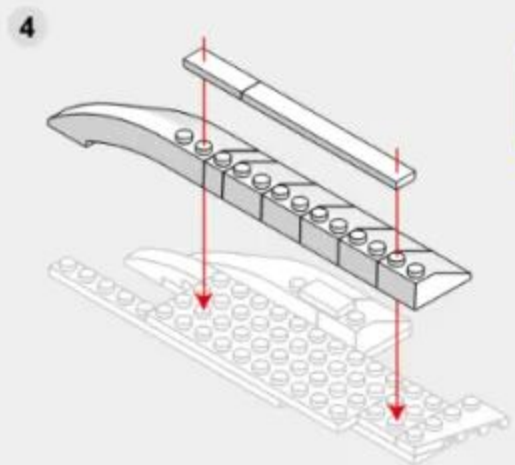
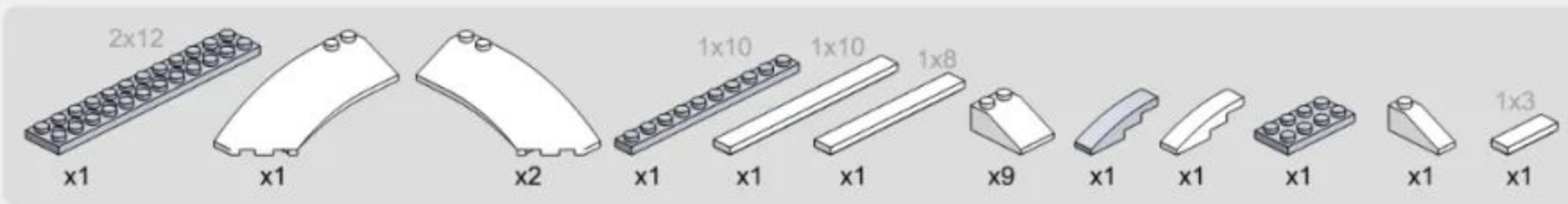

7-6



7

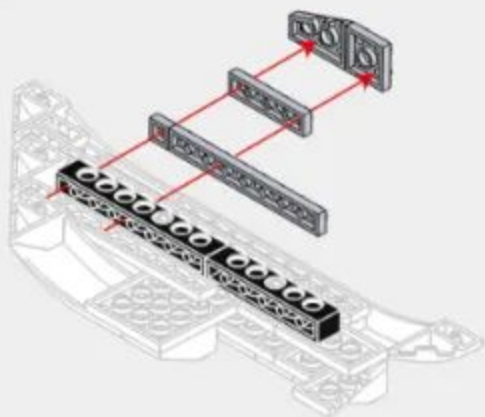

8

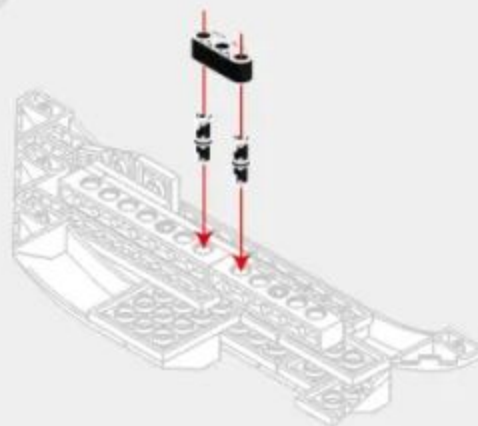

7-7

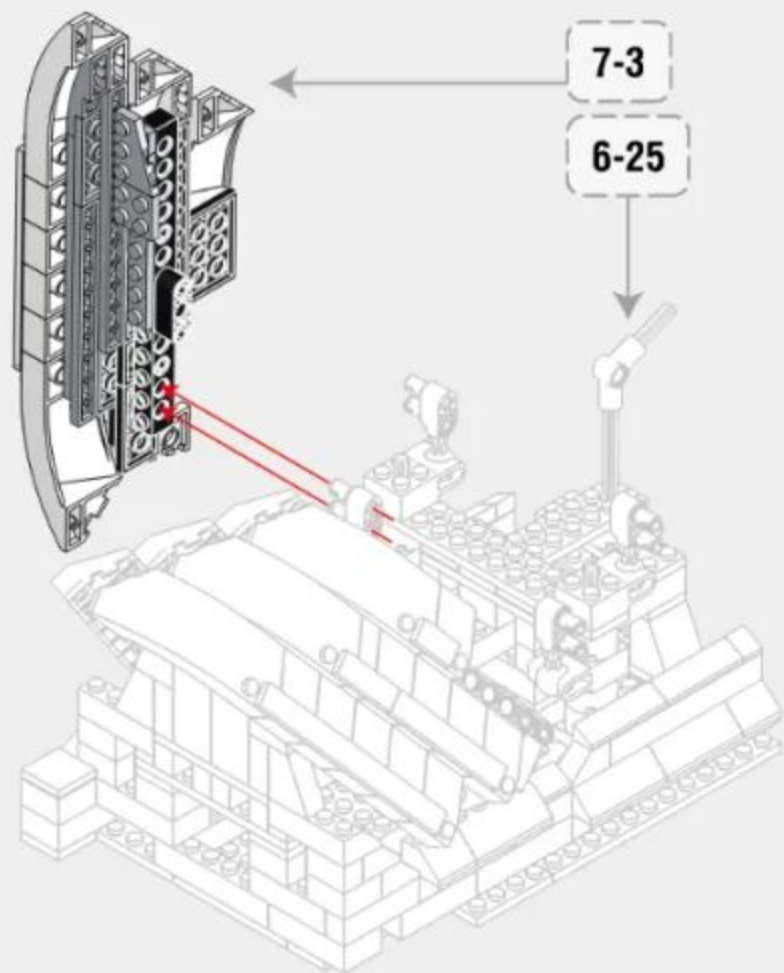

7-8

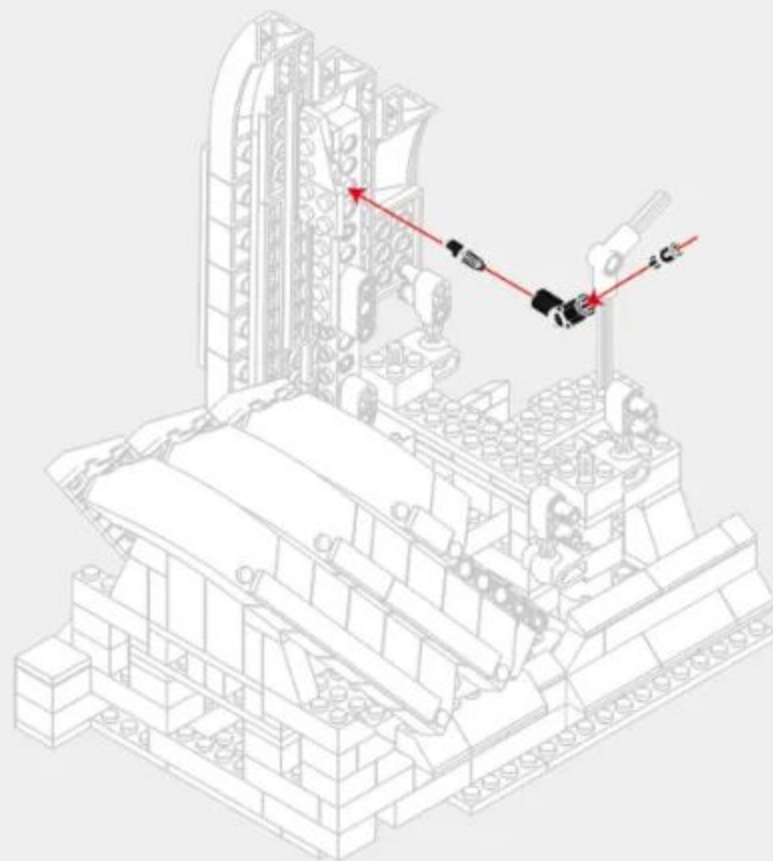

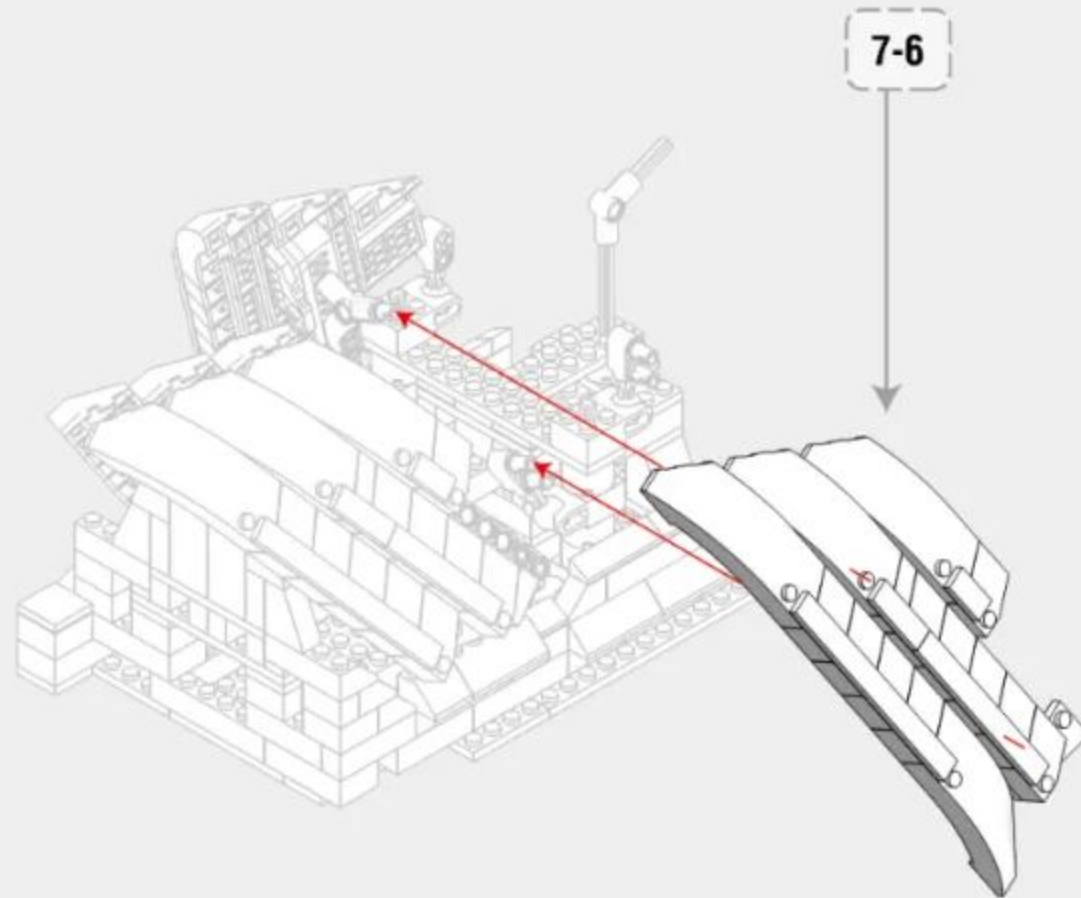

7-10

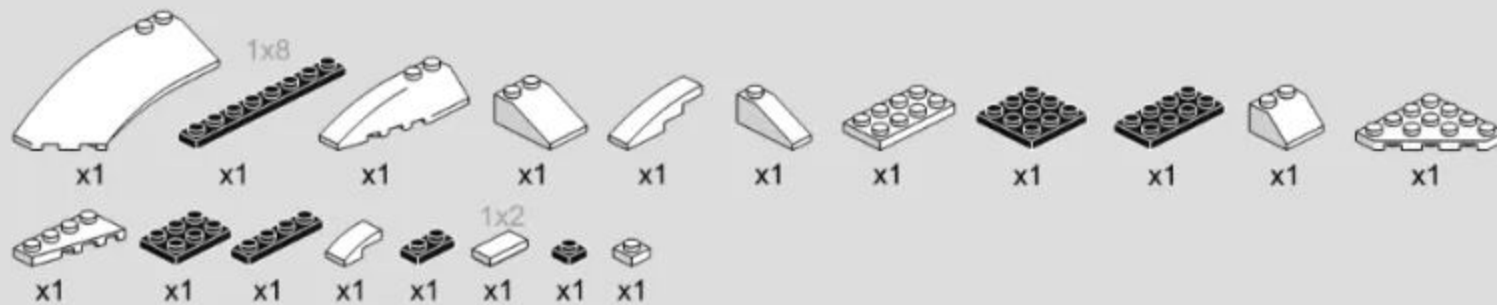

1

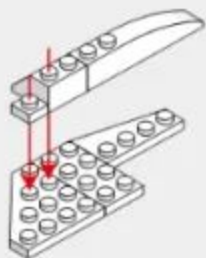

2

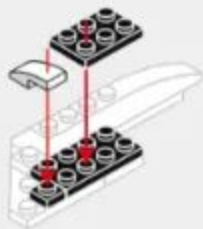

3

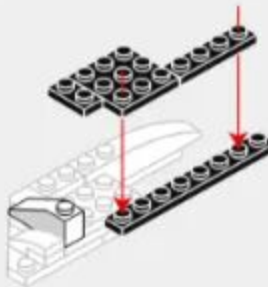

4

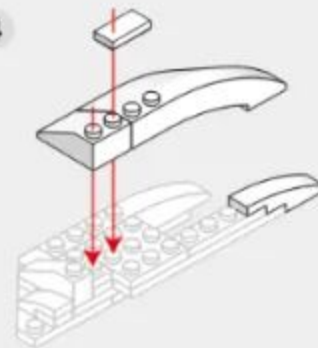

# 7-11

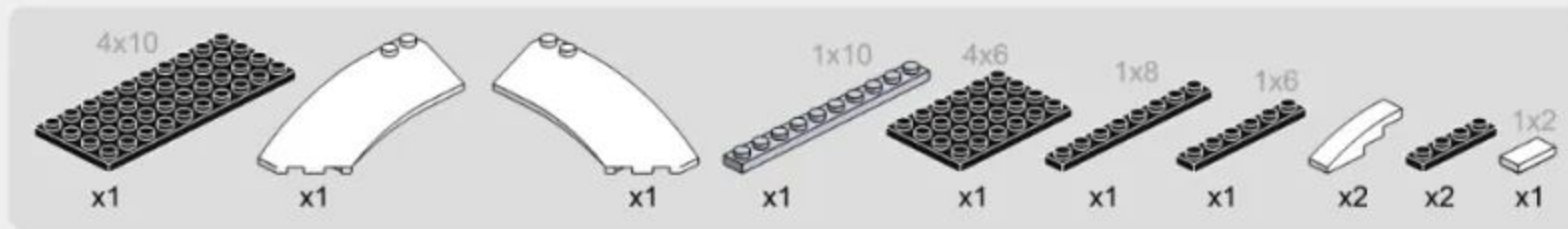

5

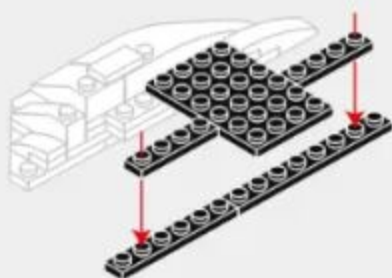

6

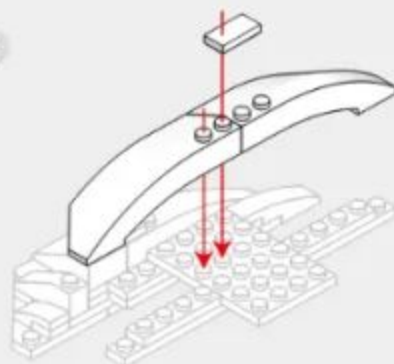

7

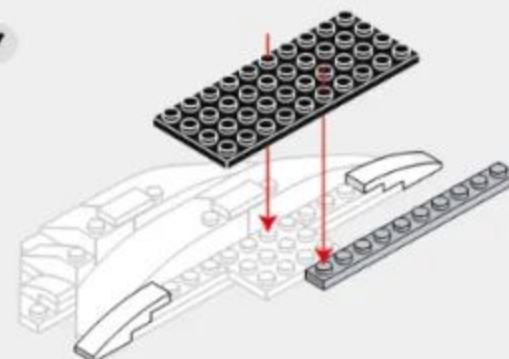

# 7-12

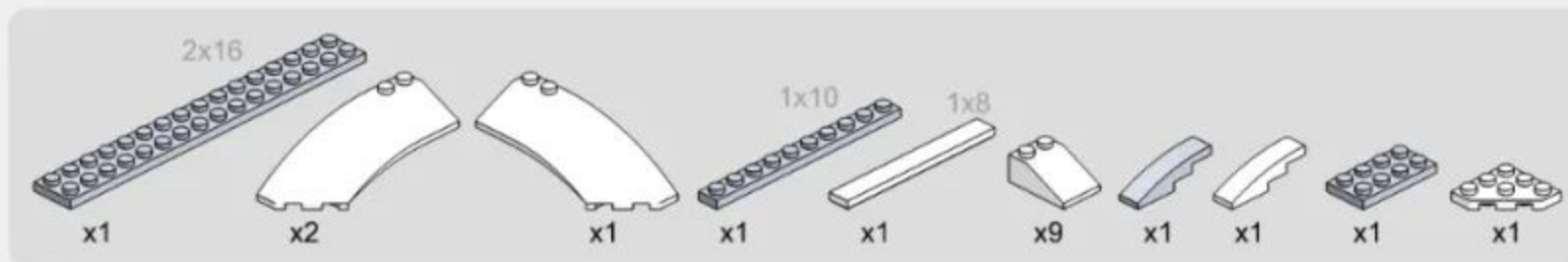

8

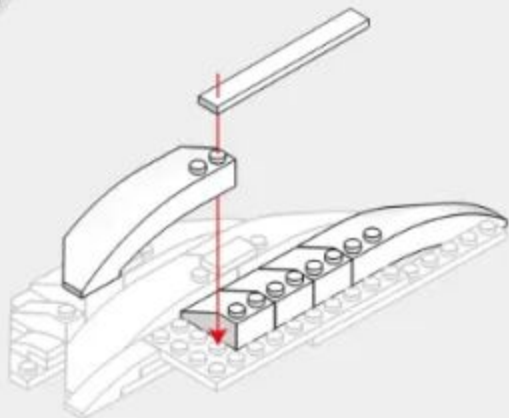

9

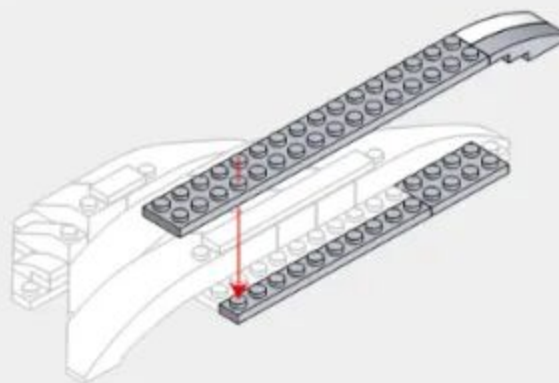

10

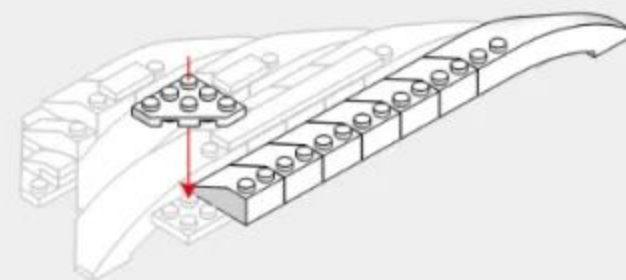

# 7-13

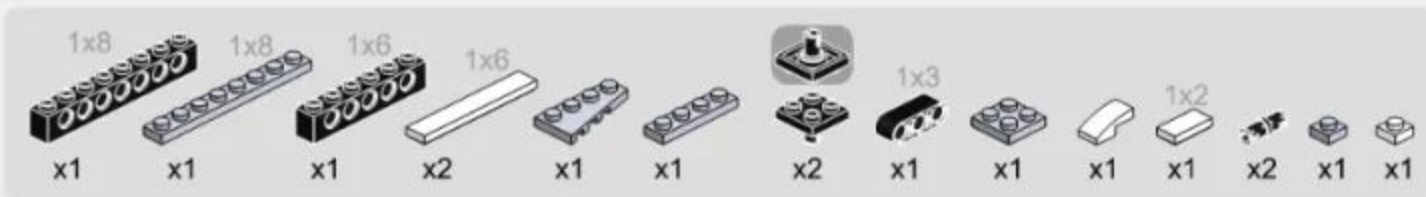

11

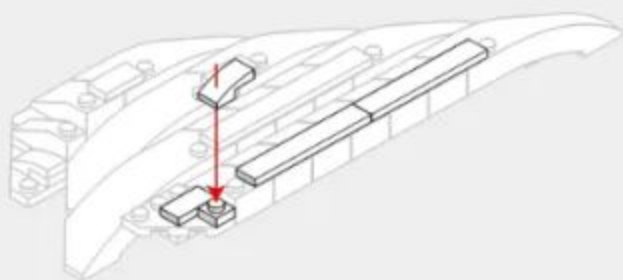

12

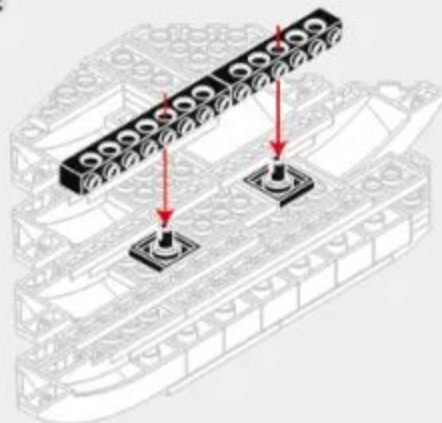

13

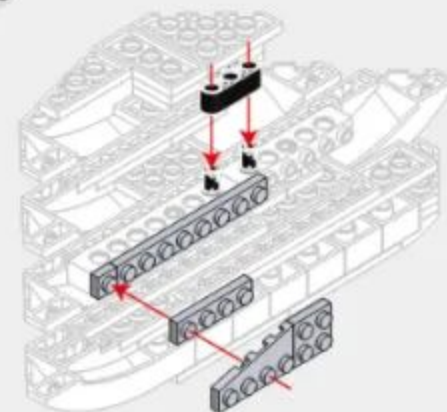

# 7-14

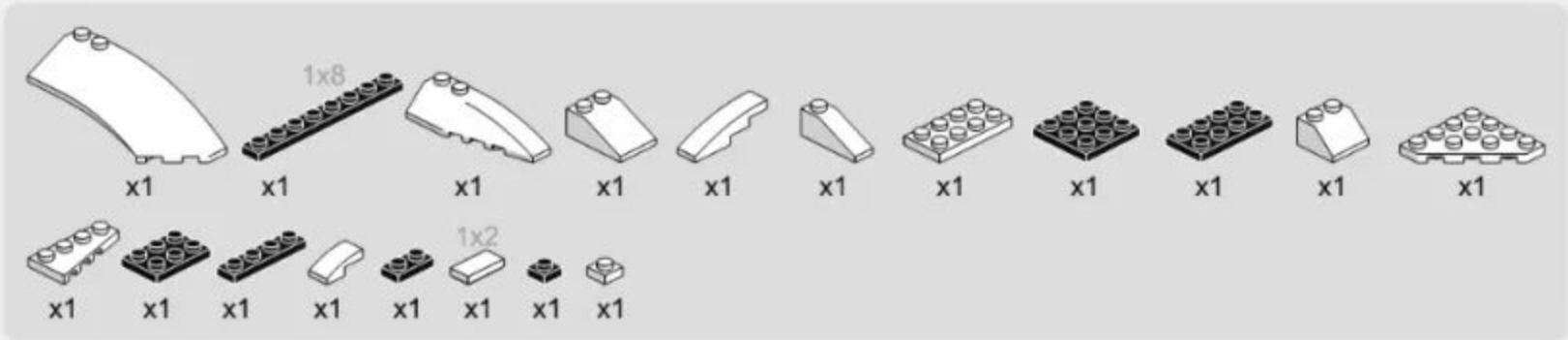

1

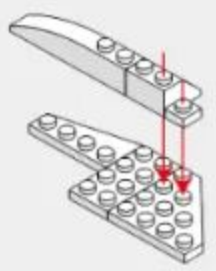

2



3

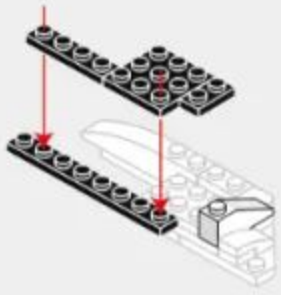

4

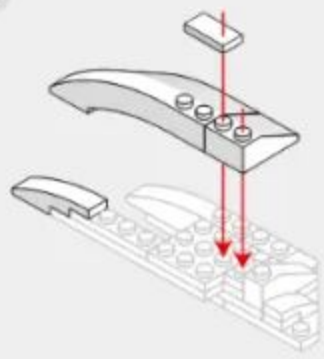

# 7-15

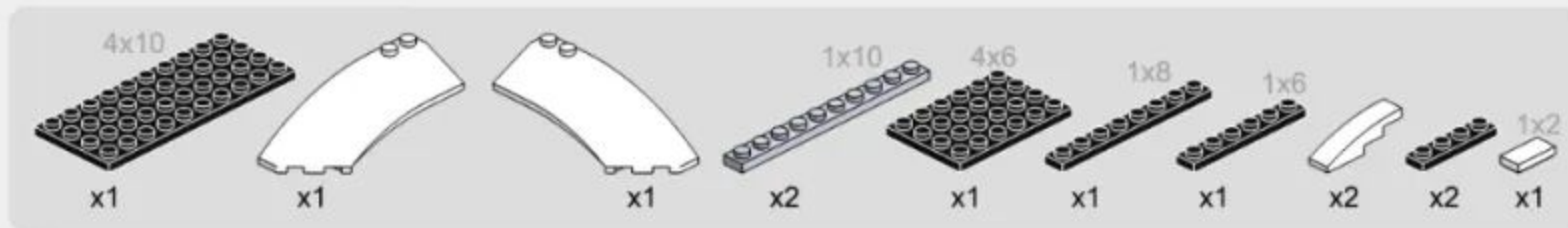

5

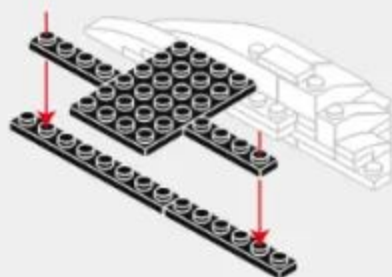

6

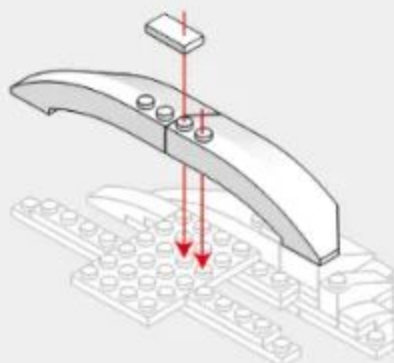

7

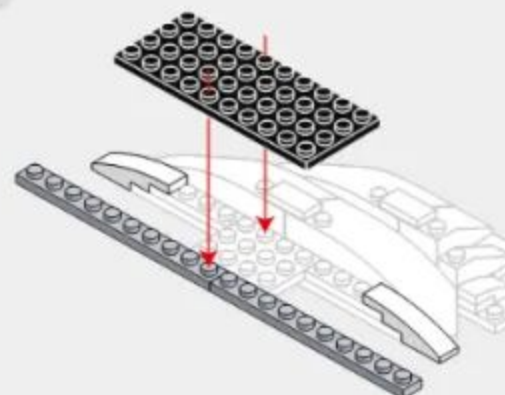

# 7-16

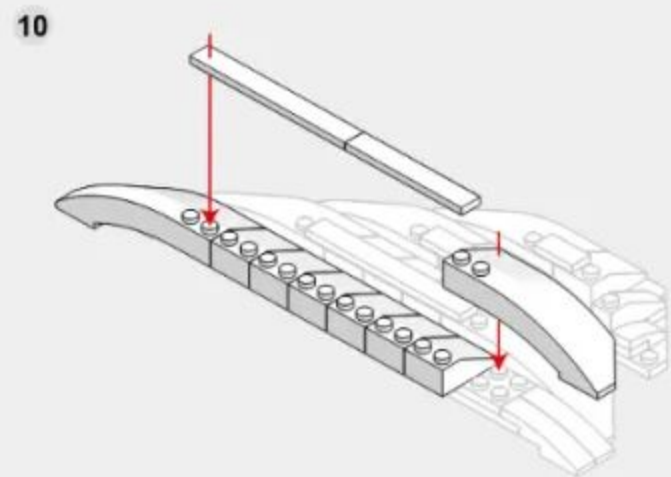
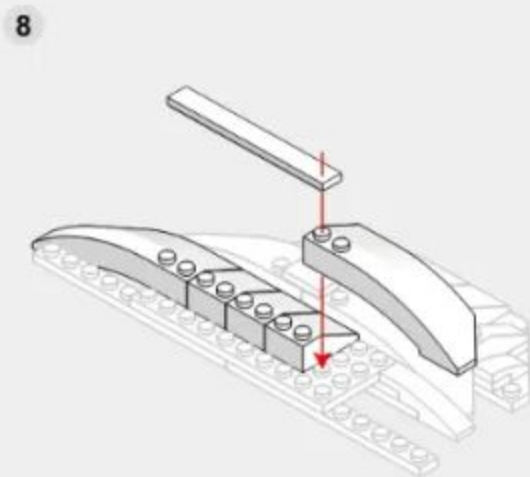
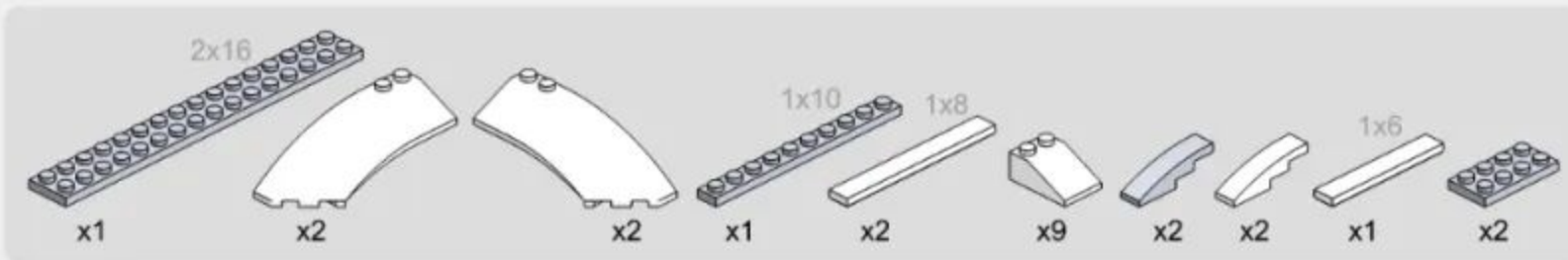

7-17

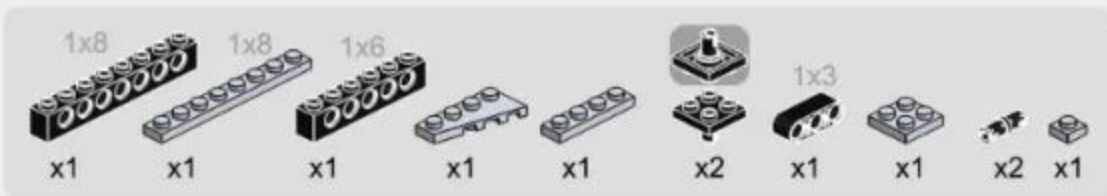

11

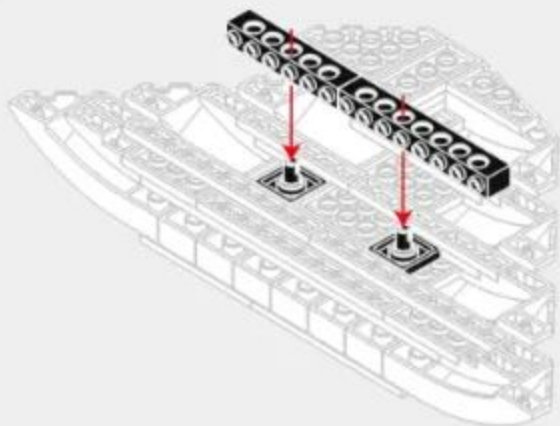

12

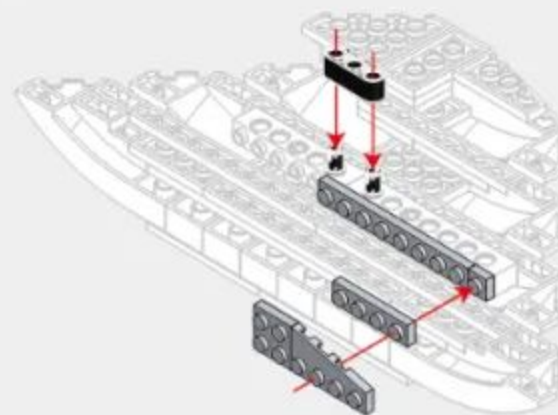

7-18

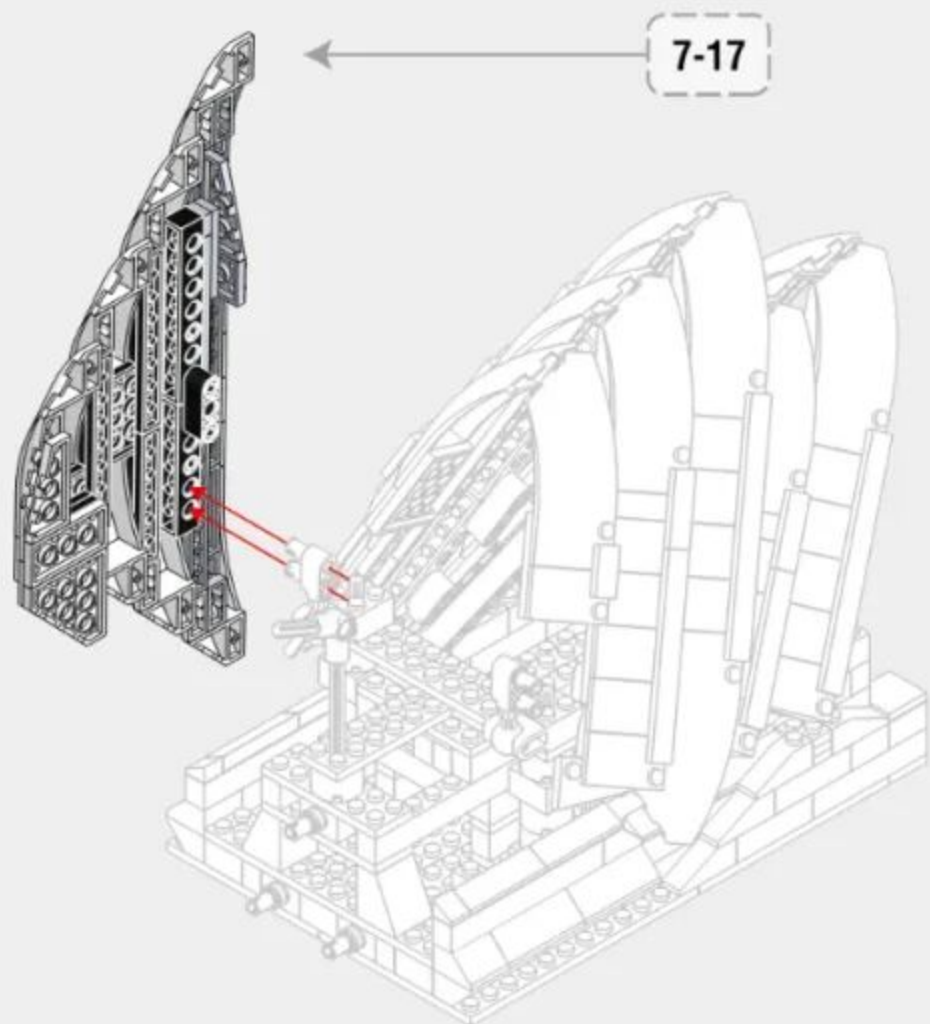

7-19

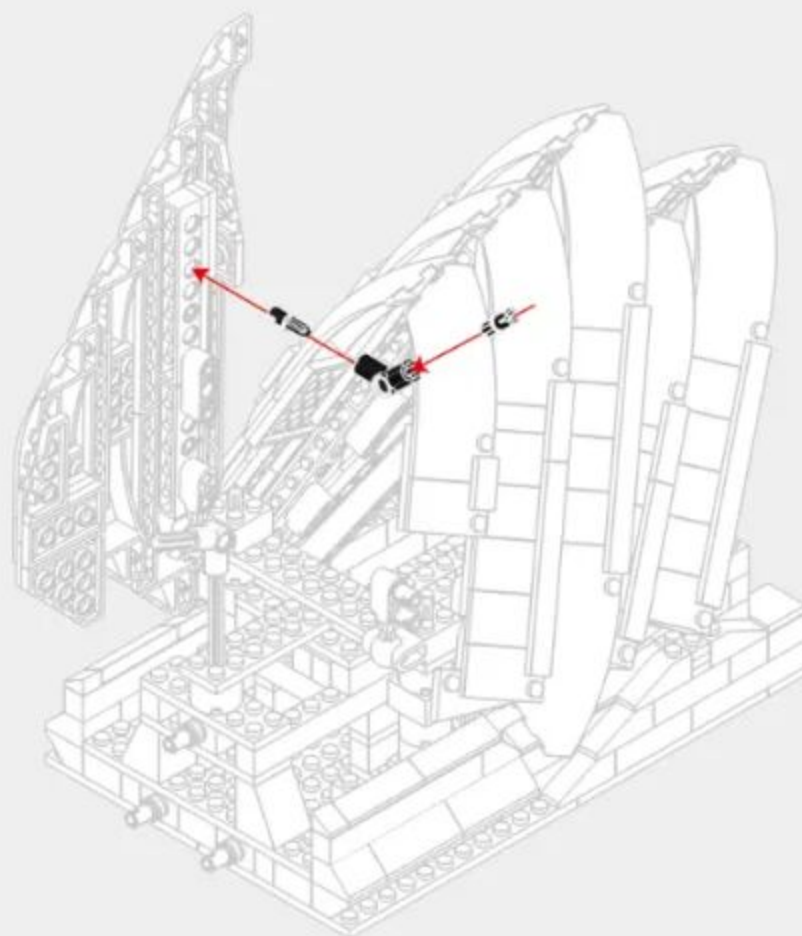

7-20

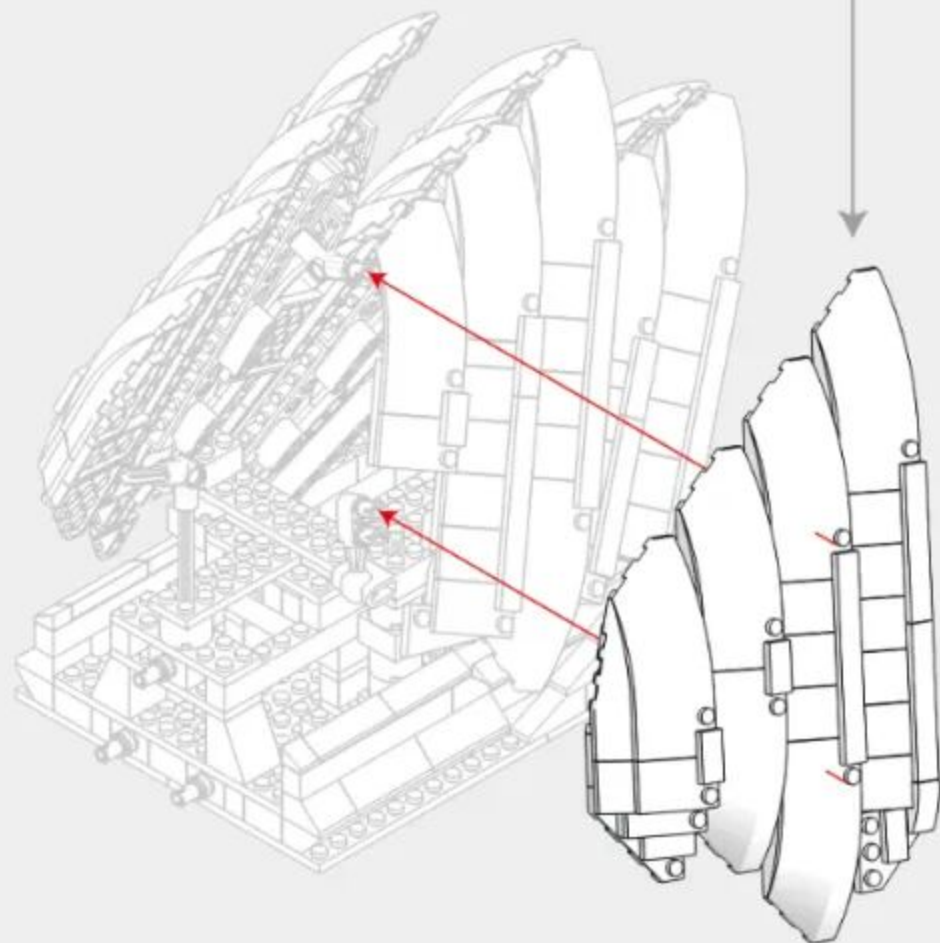

7-21

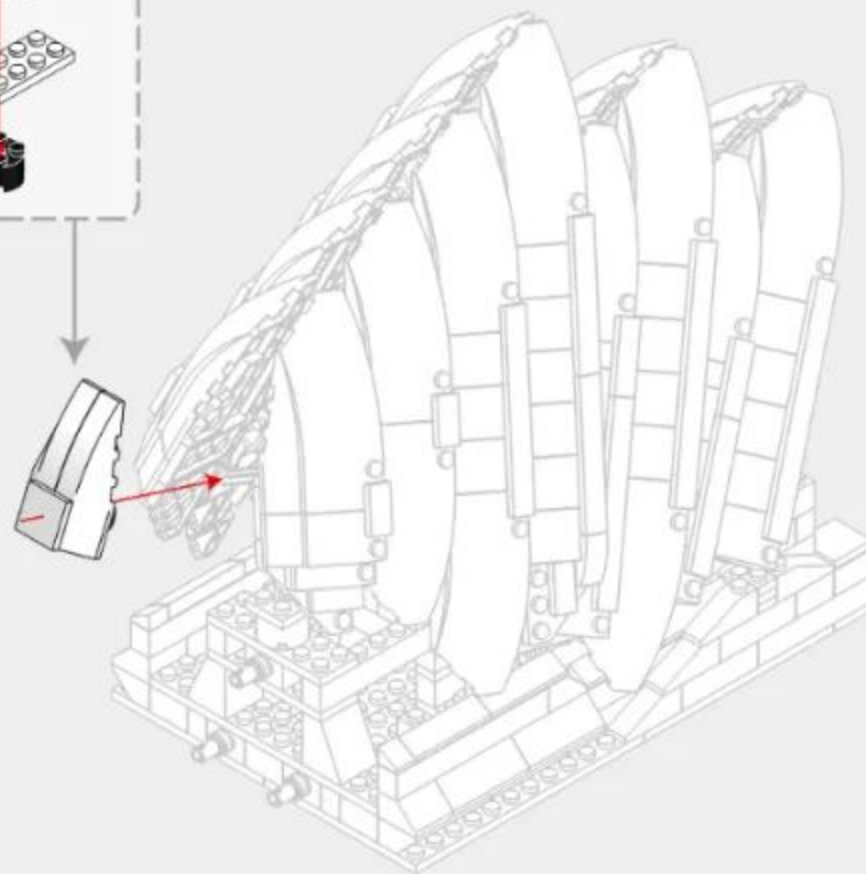
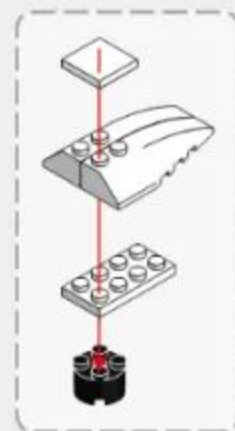
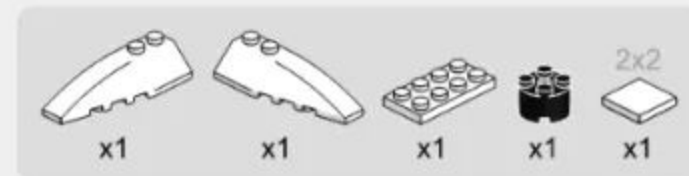



251 PCS

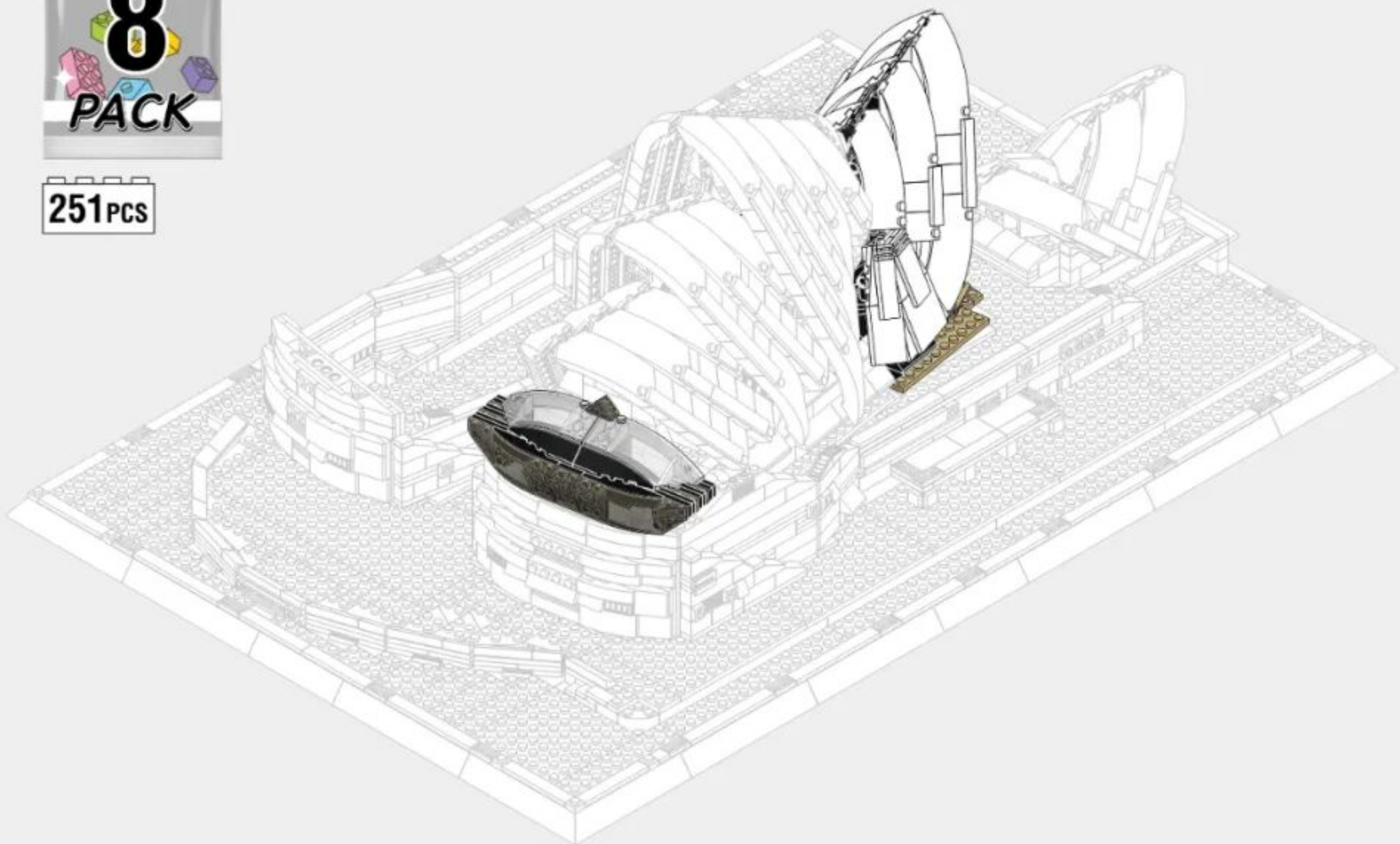

167

# 8-1

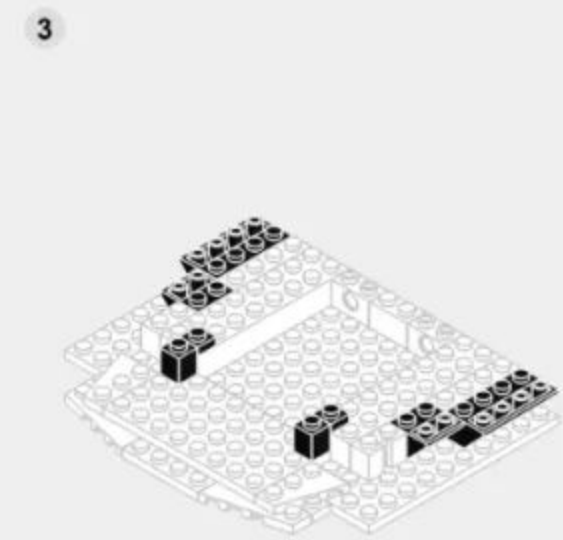
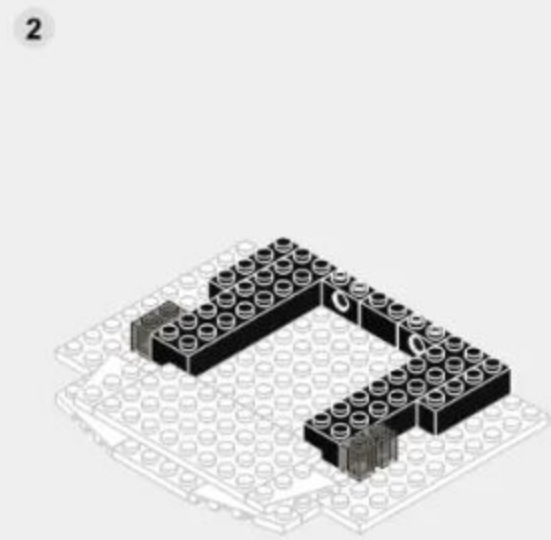
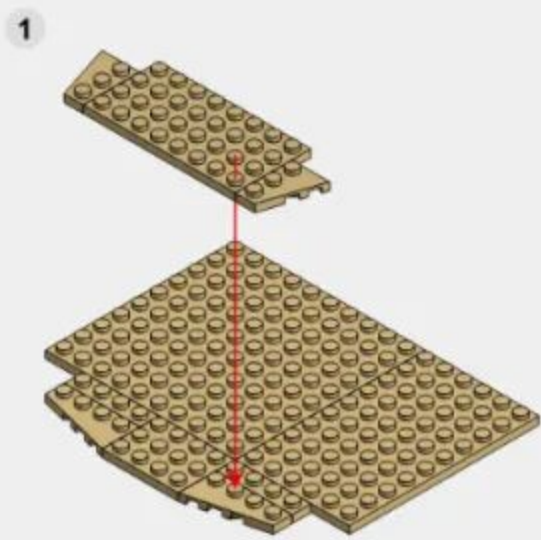
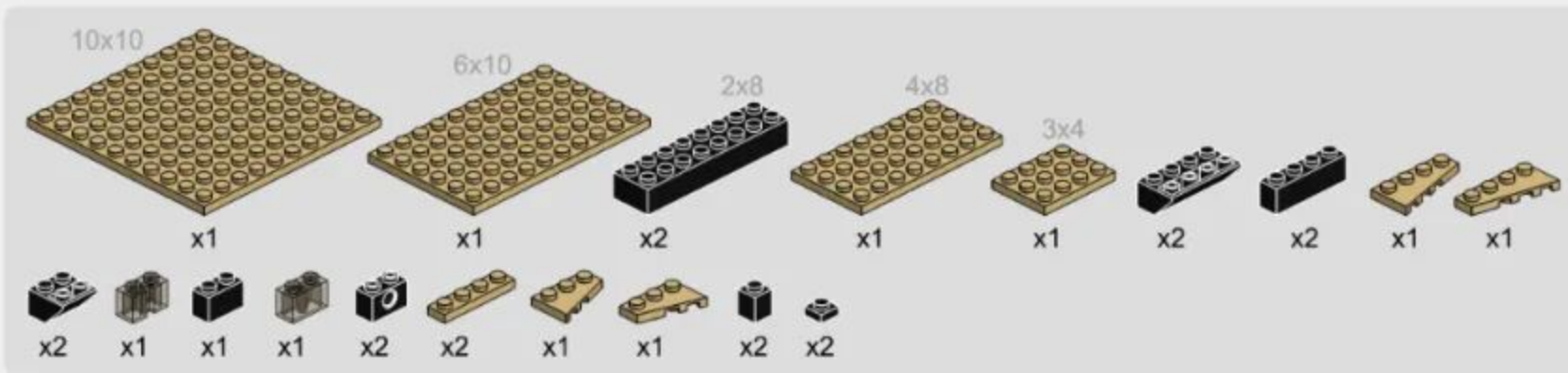

# 8-2



4



5

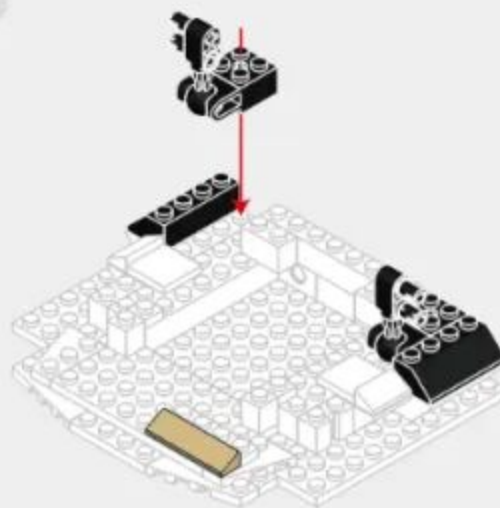

6

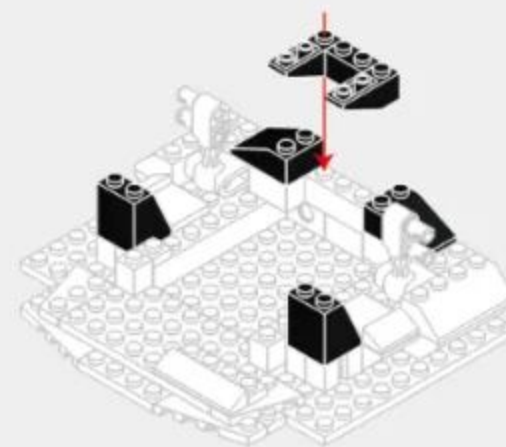

# 8-3



7

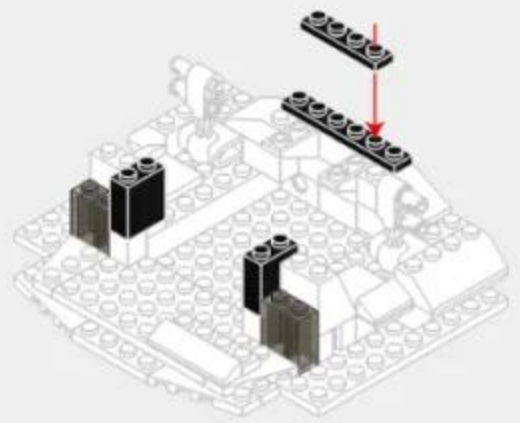

8

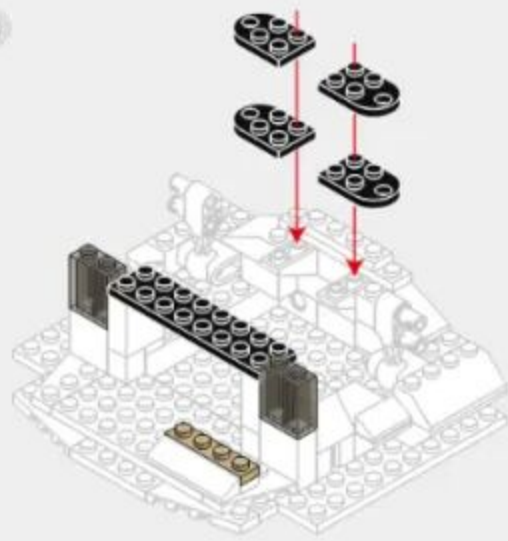

9

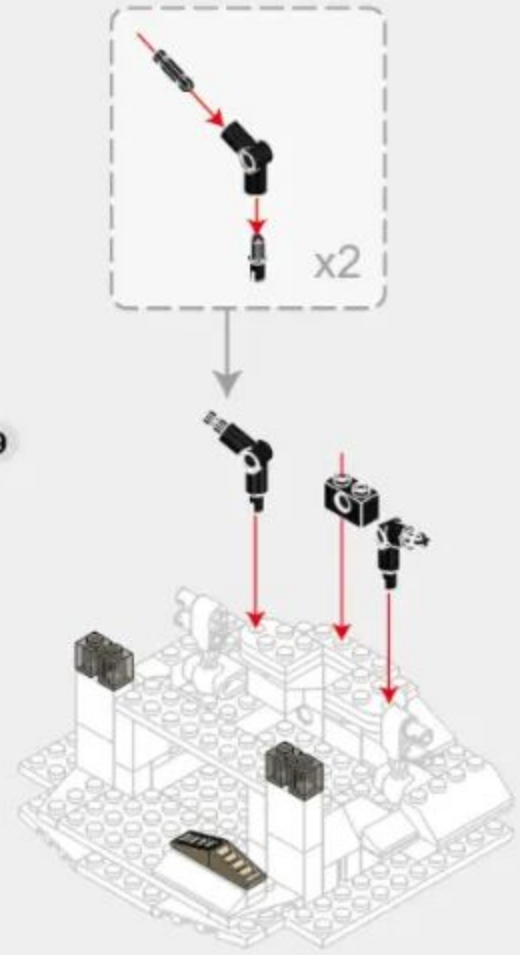

# 8-4



10

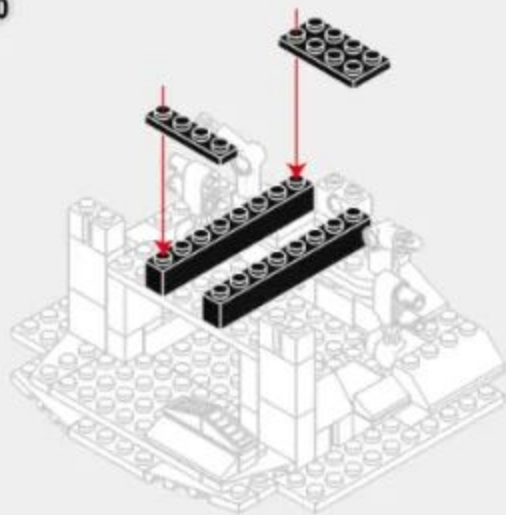

11

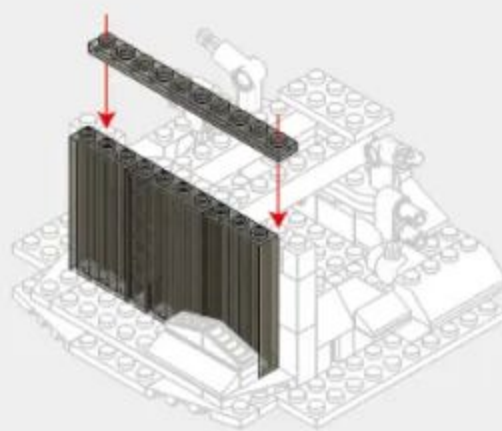

12

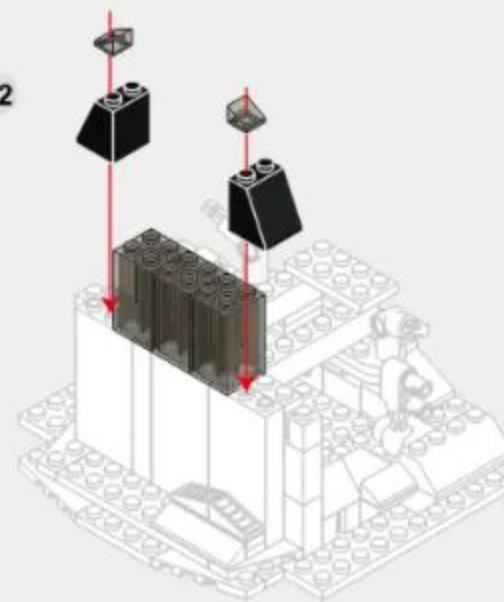

8-5



13

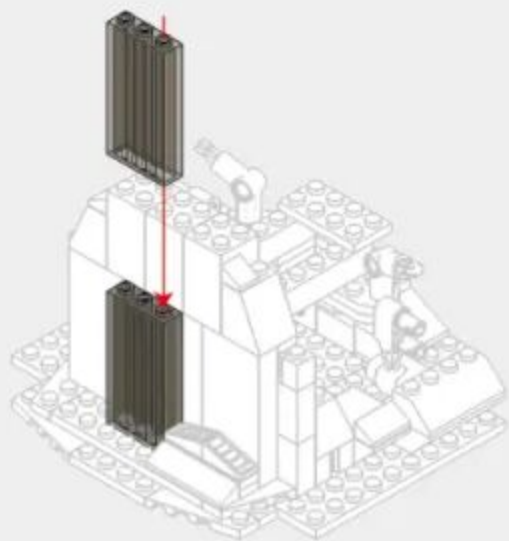

14

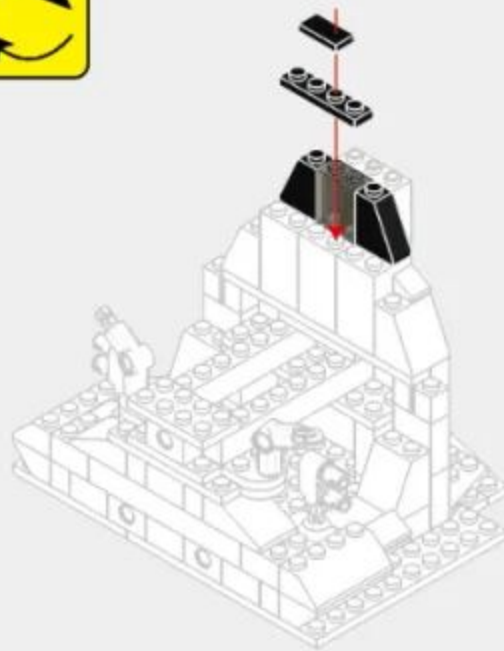

15

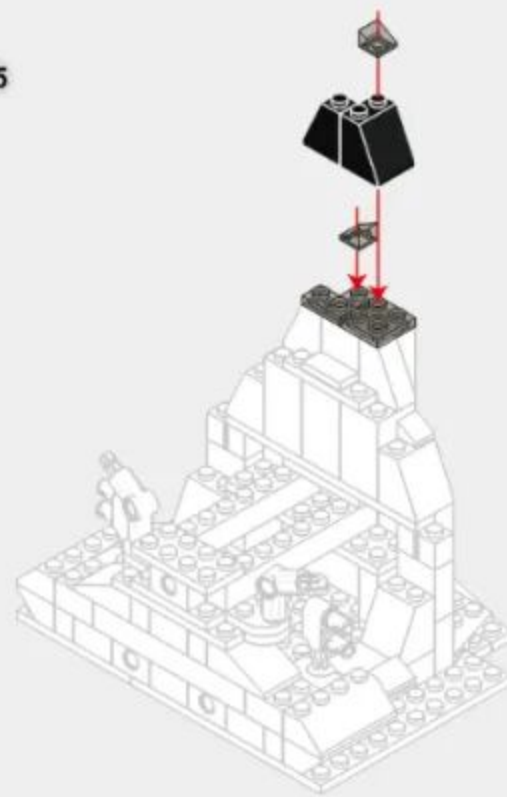

# 8-6

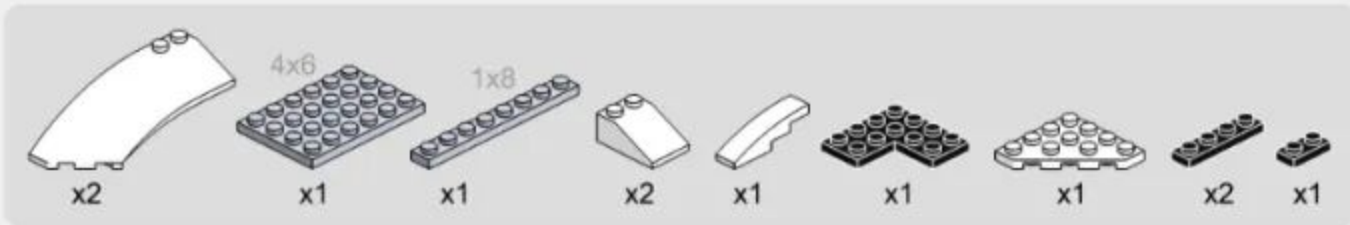

1



2



3

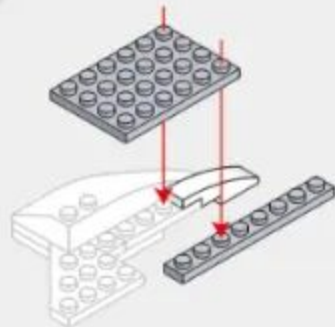

4

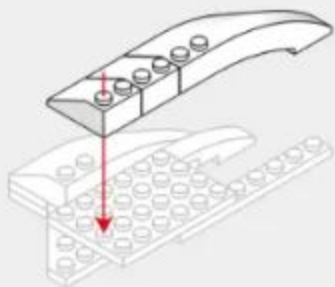

# 8-7

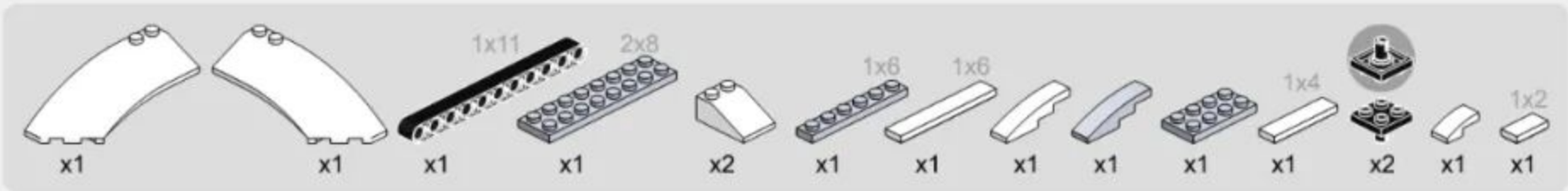

5

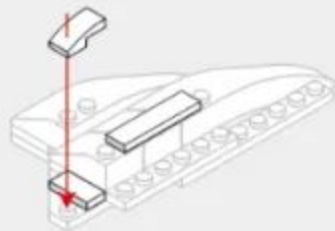

6

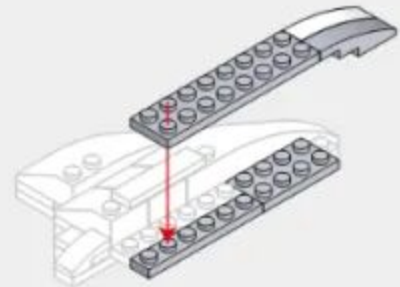

7

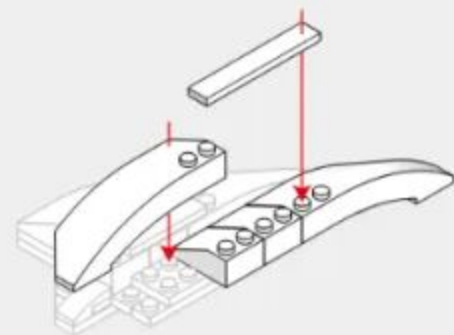

8

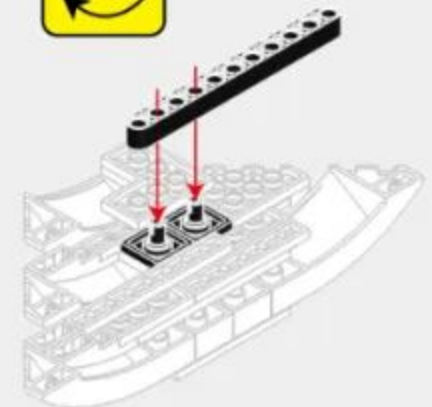

8-8

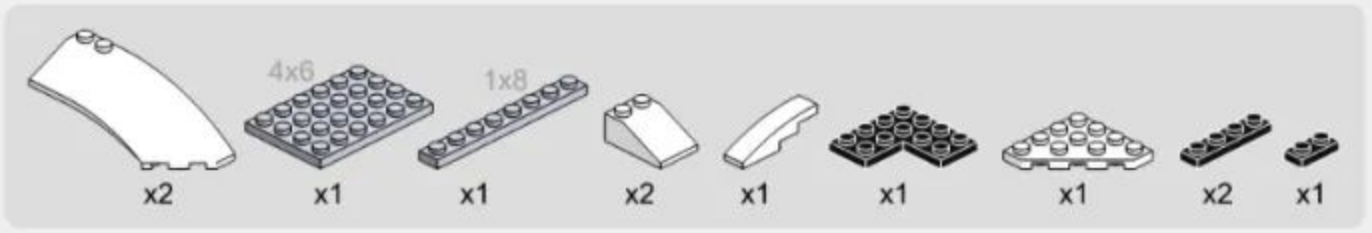

1



2



3

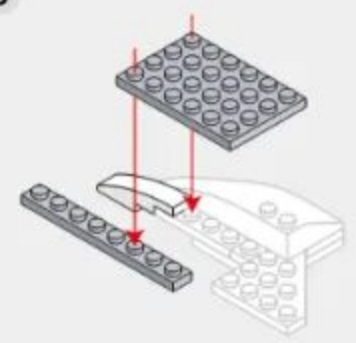

4

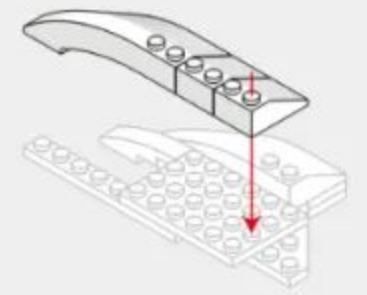

# 8-9

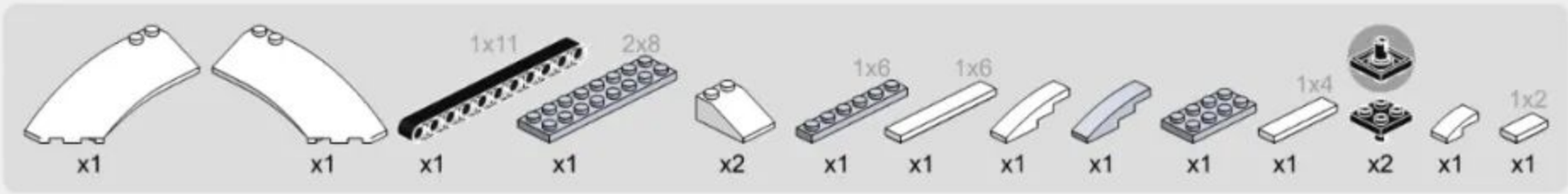

5

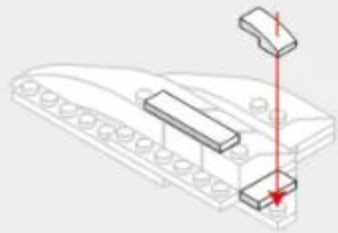

6

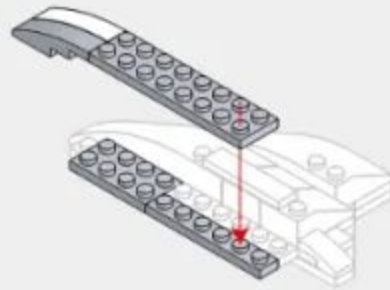

7

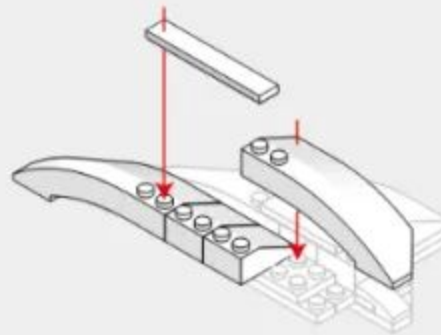

8

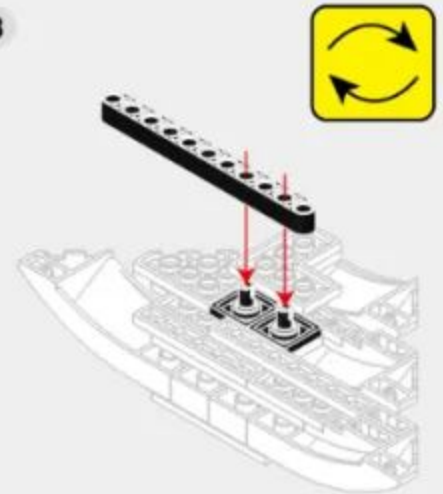

8-10

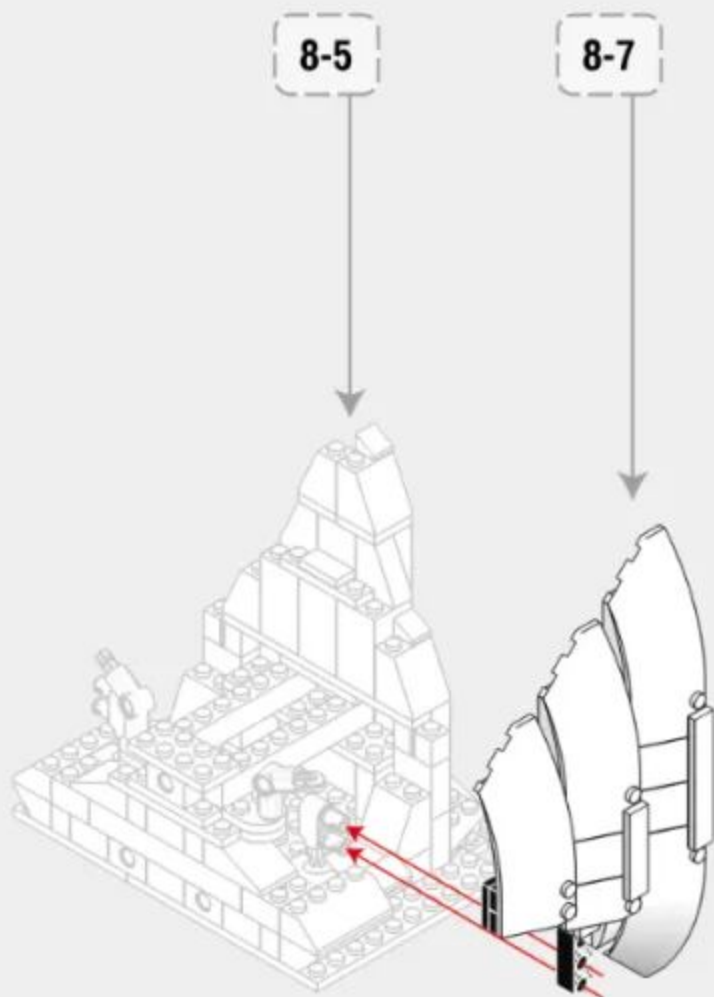

8-11

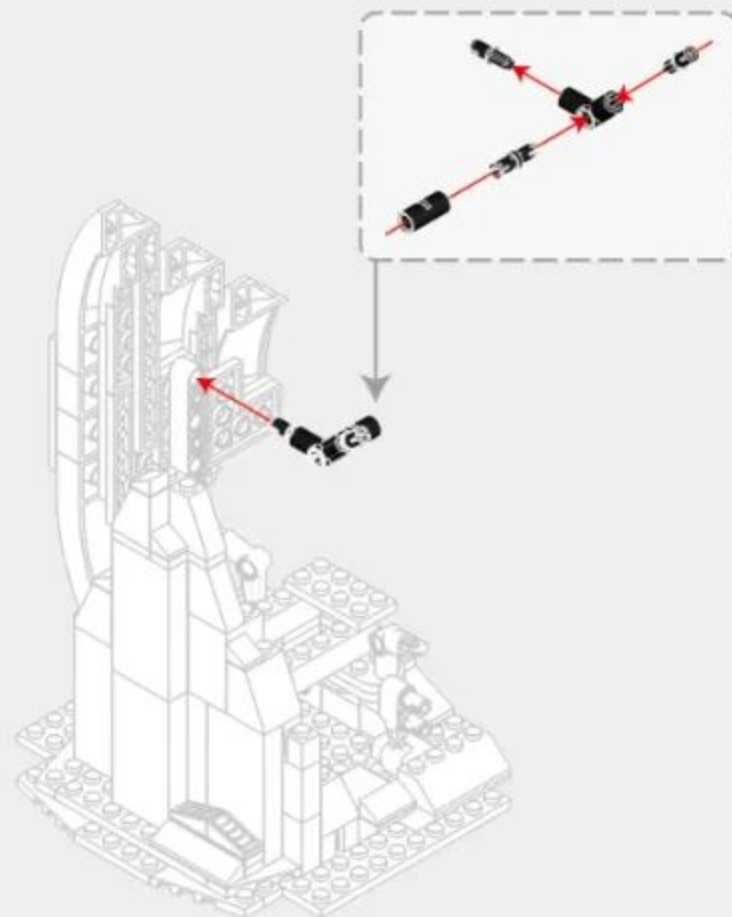

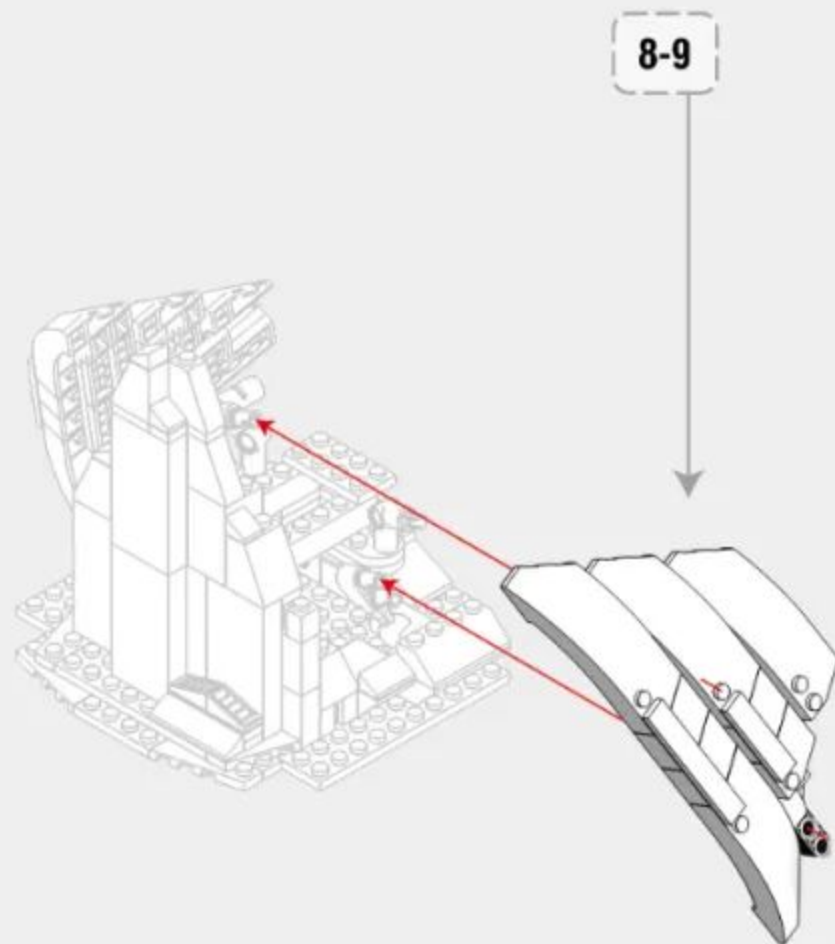

### 8-13

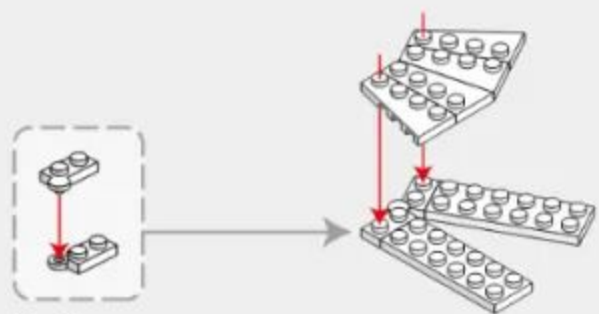
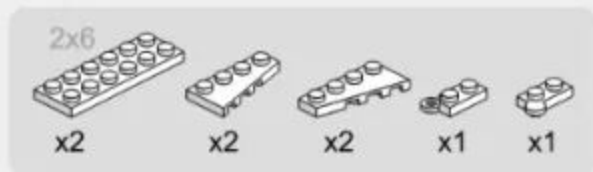

### 8-15

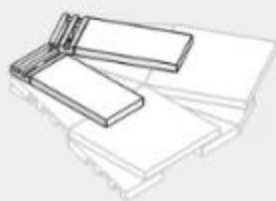
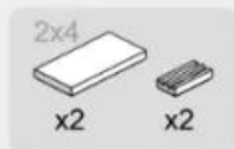

### 8-14

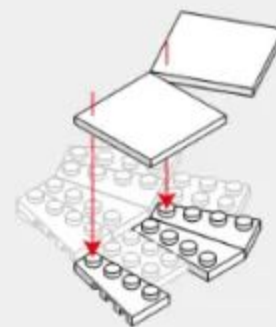
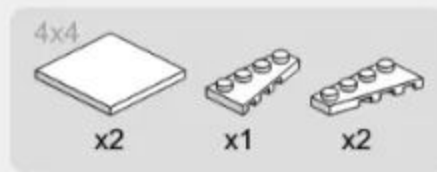

### 8-16

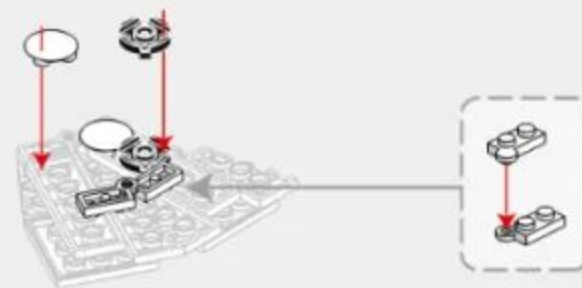

### 8-17

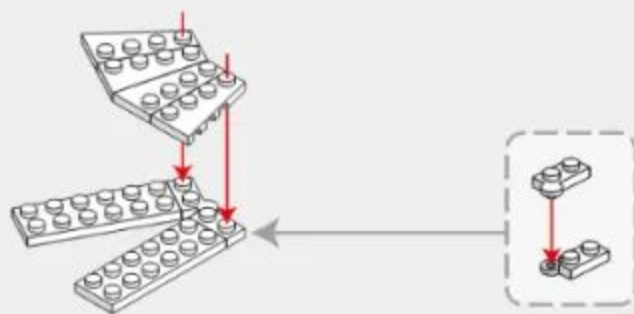
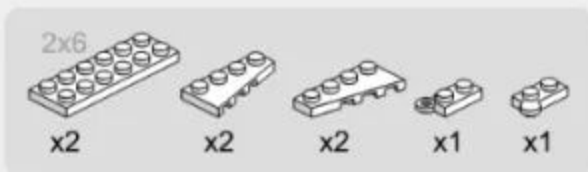

### 8-18

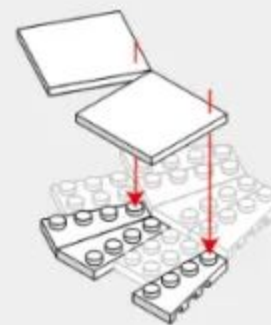
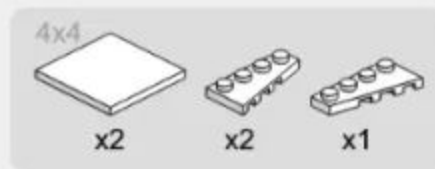

### 8-19

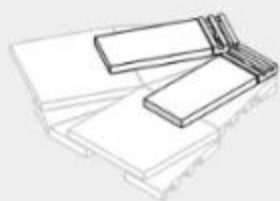
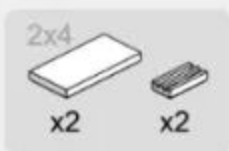

### 8-20

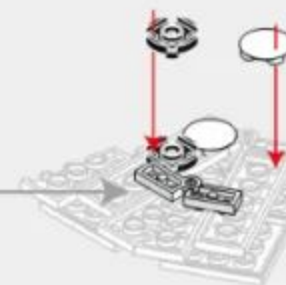

8-21

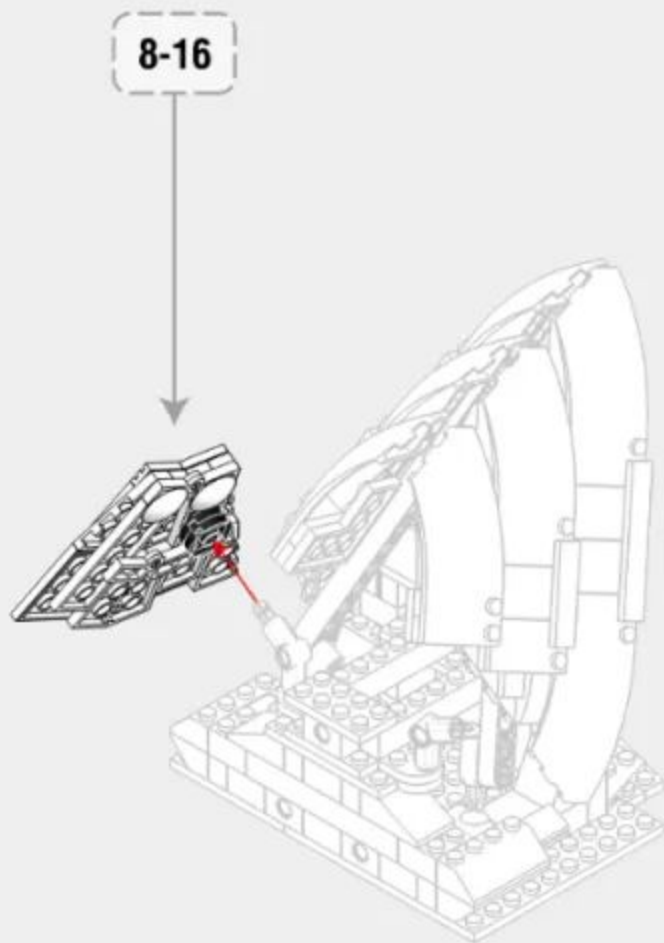

8-22

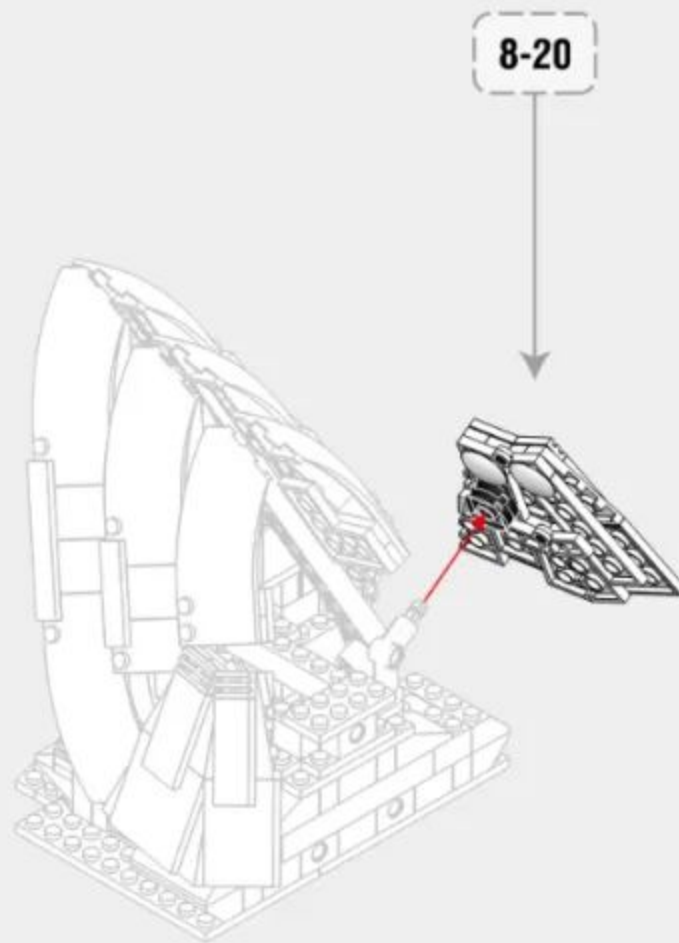

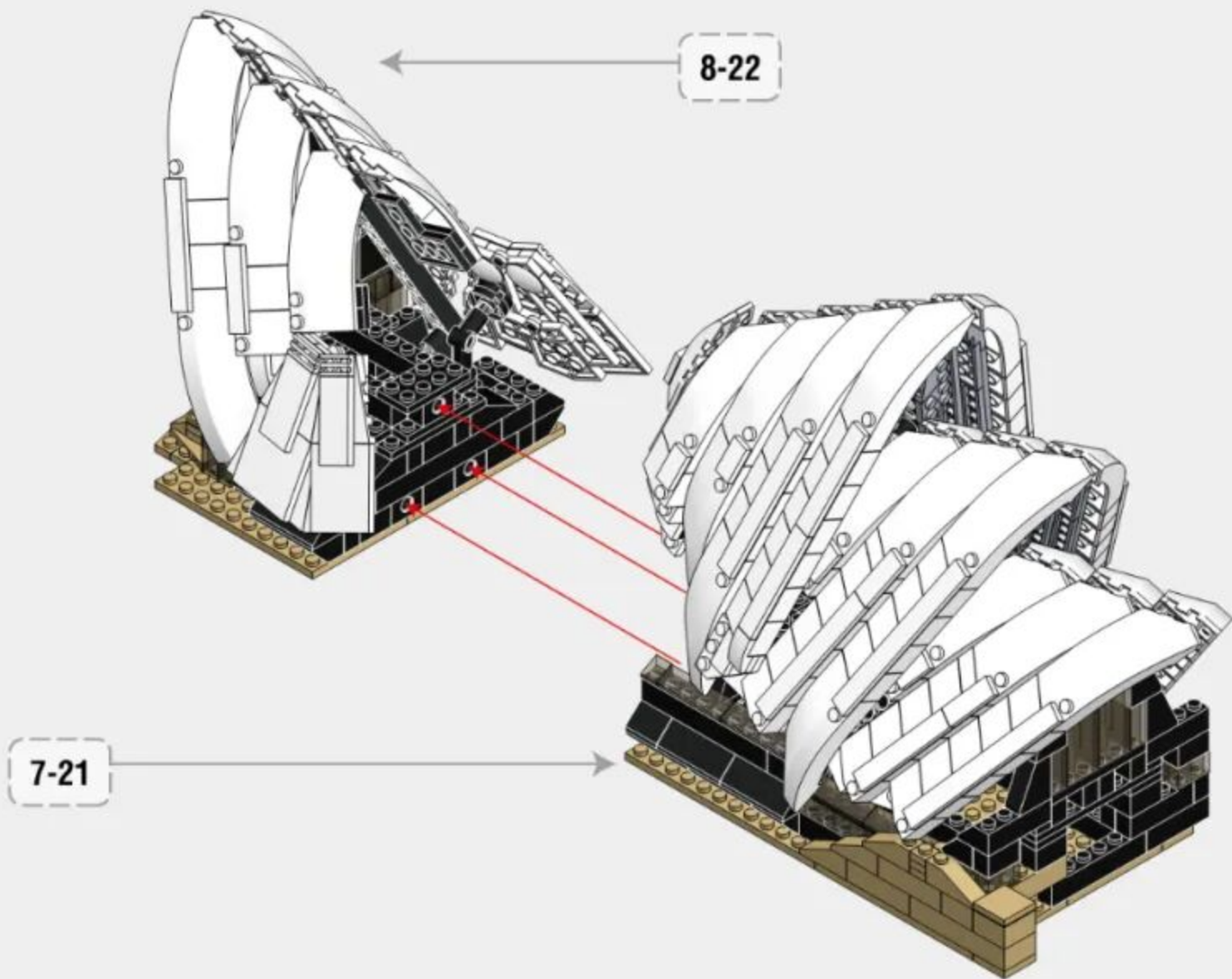

8-24

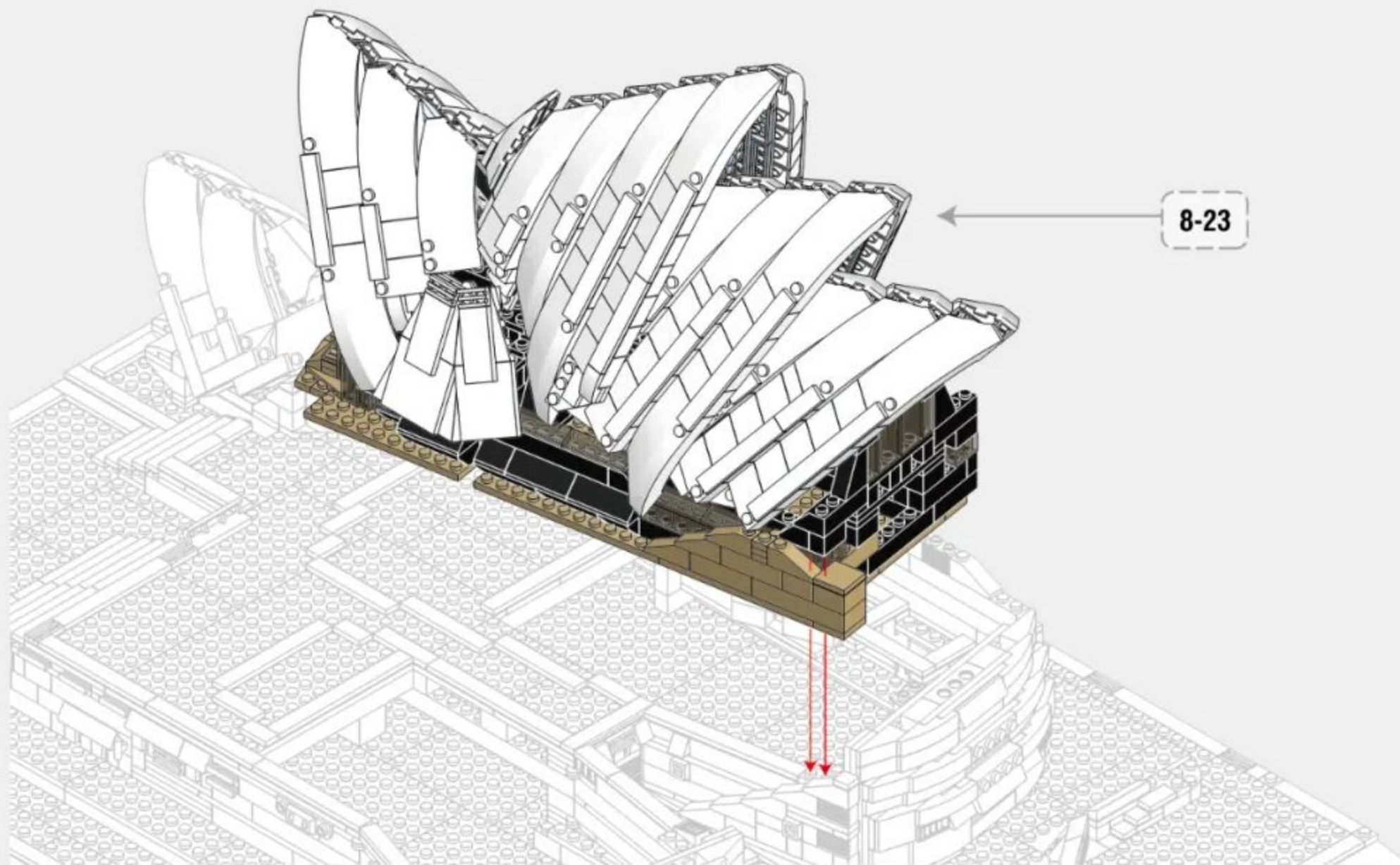

8-25

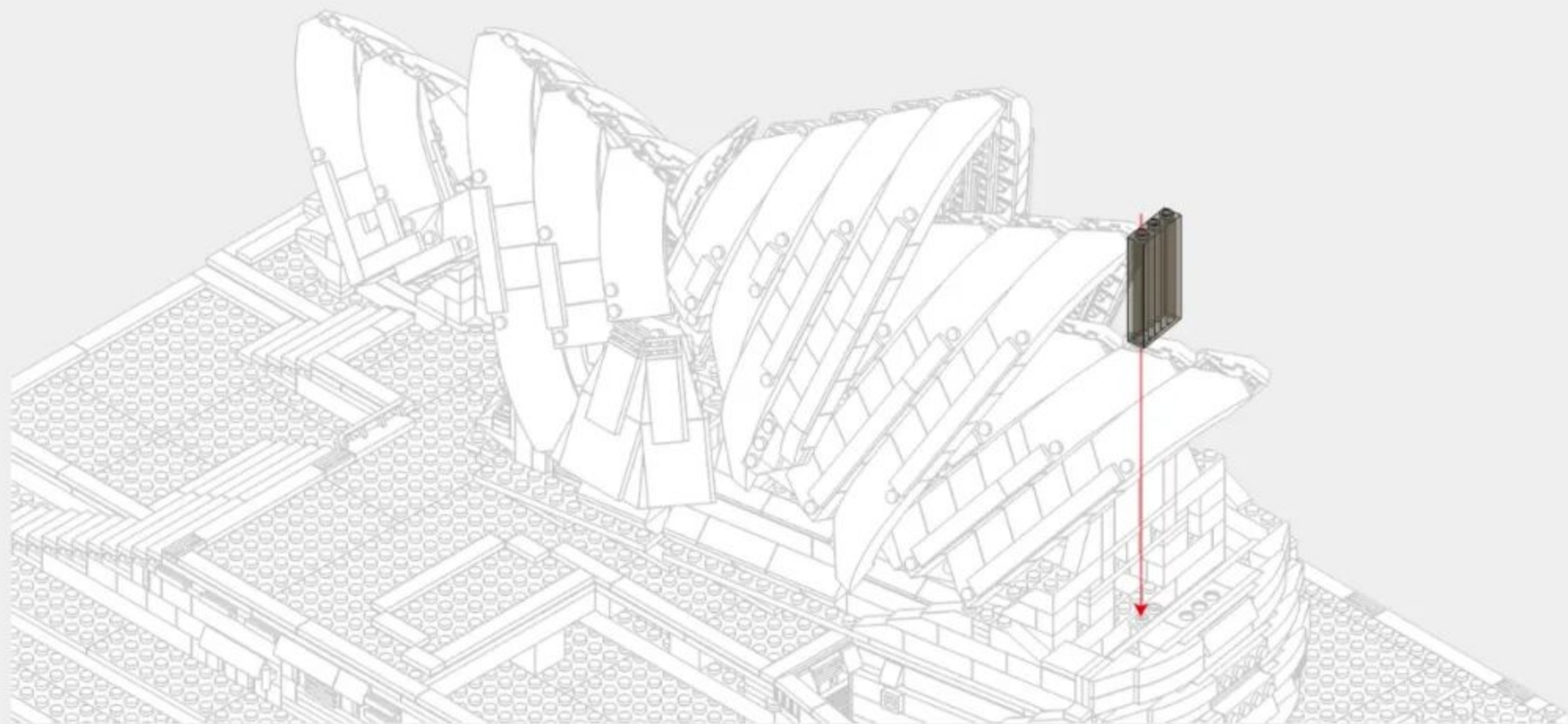

8-26

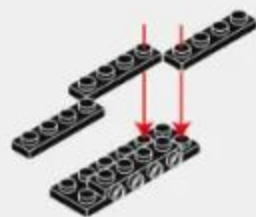
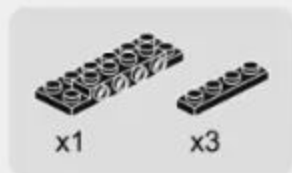

8-27

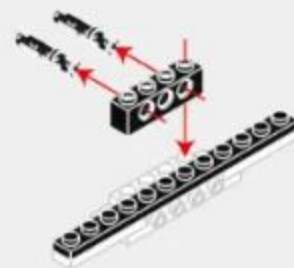

8-28

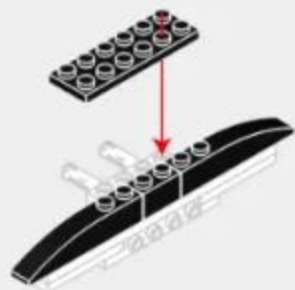
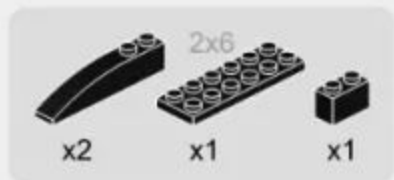

8-29

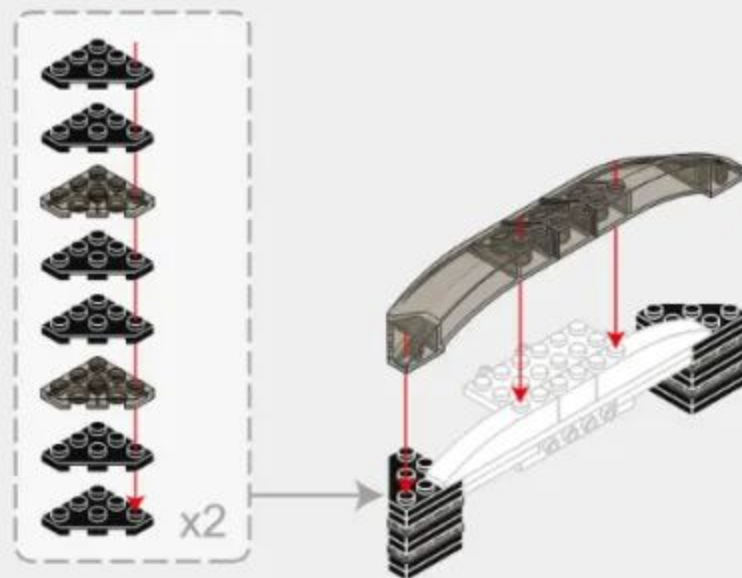

8-30

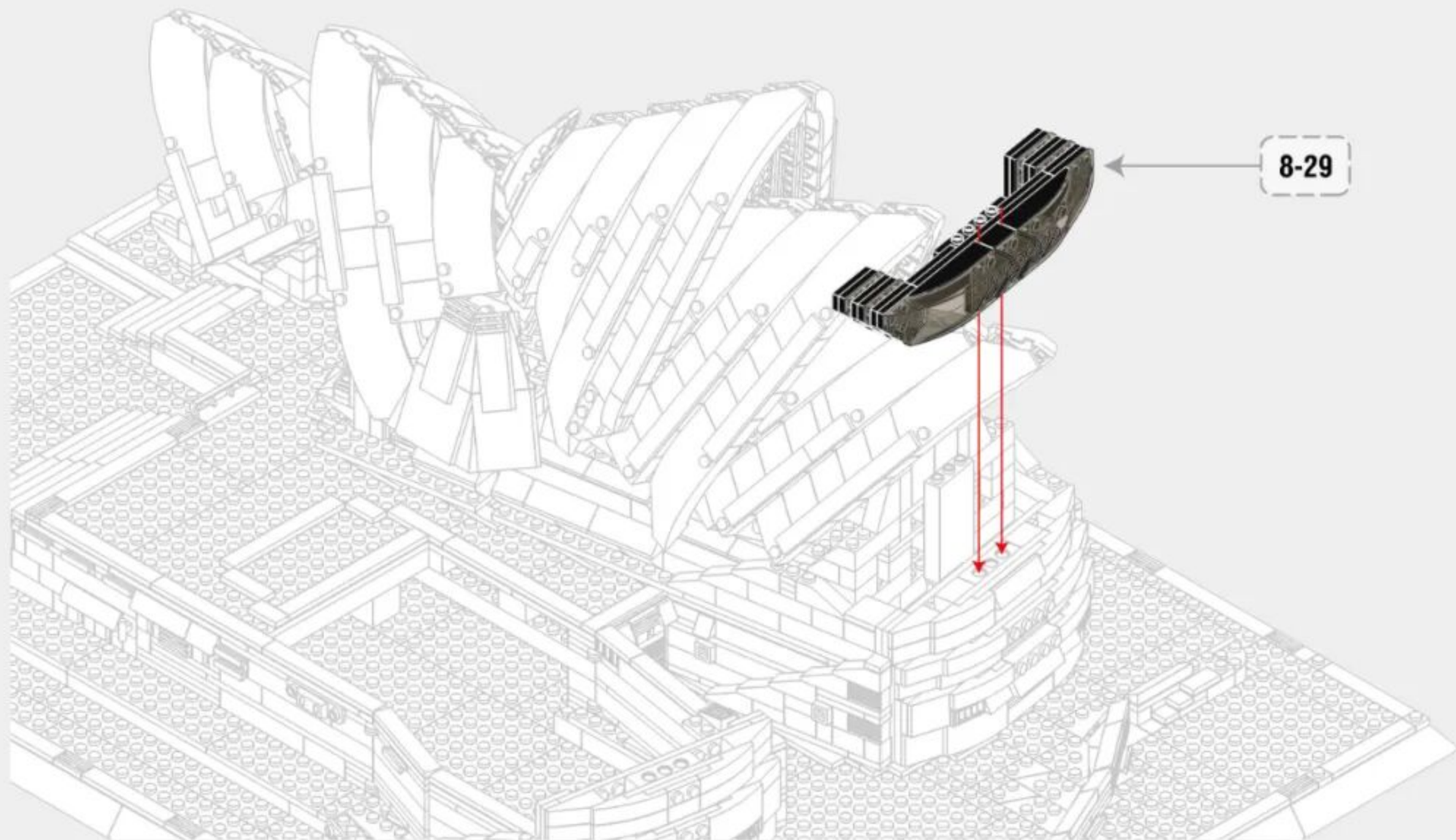

8-31

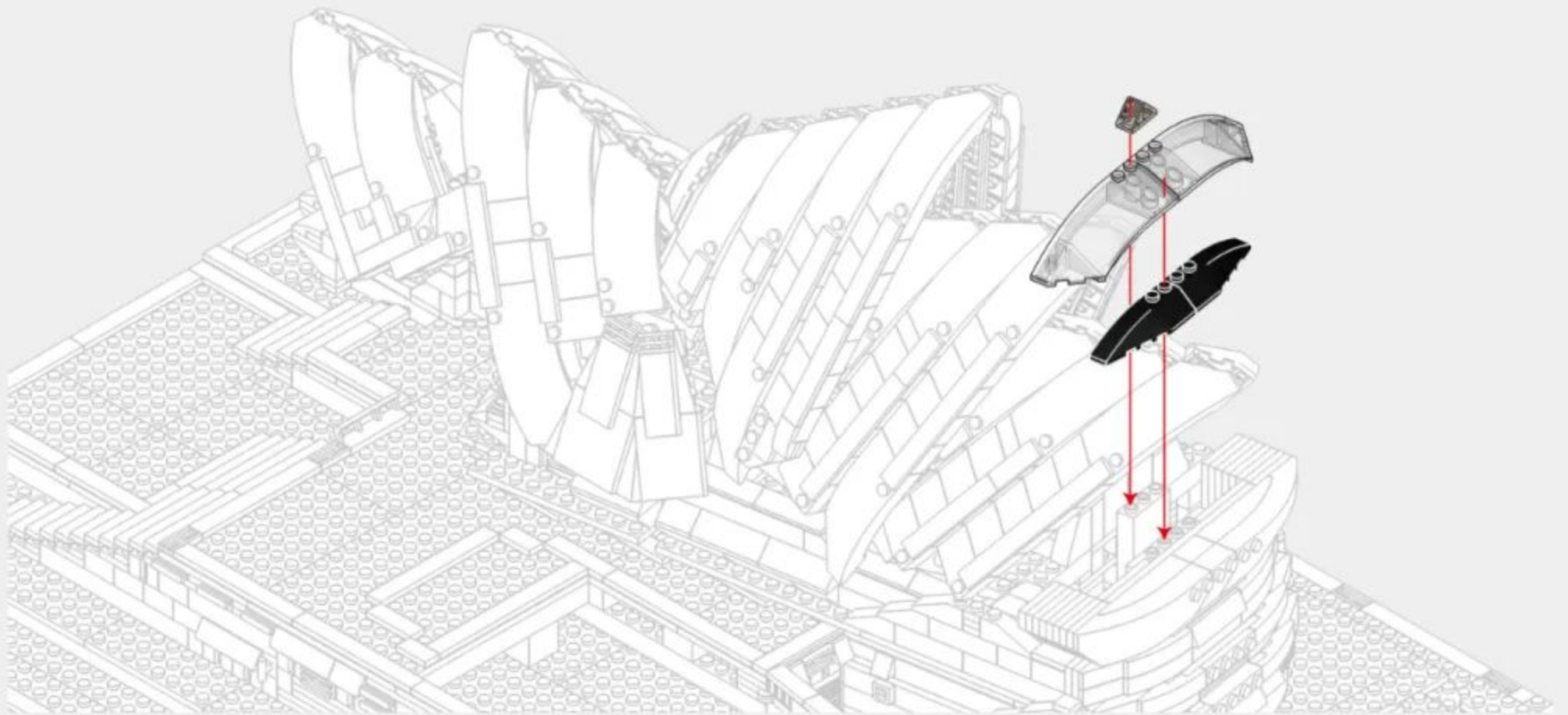
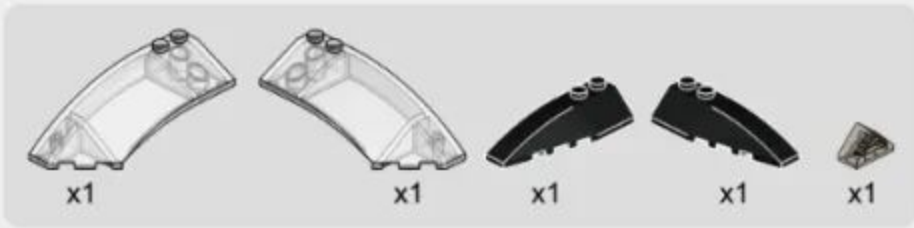



250PCS

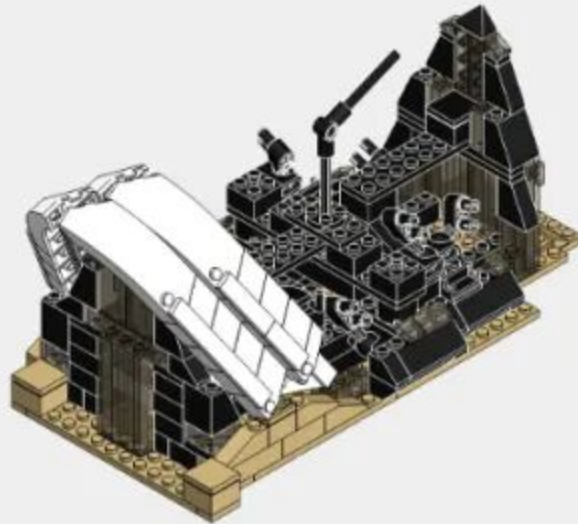

# 9-1

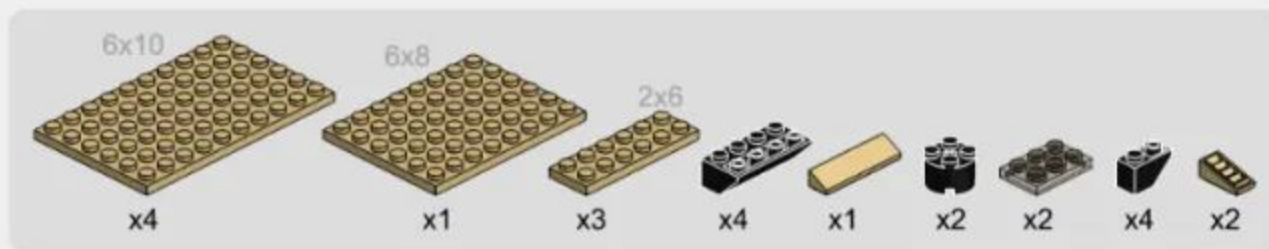

1

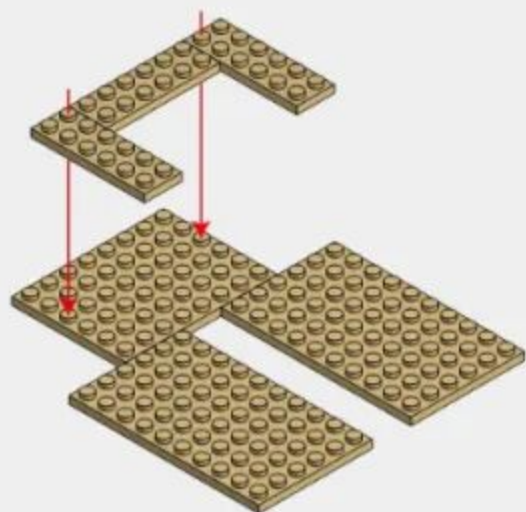

2

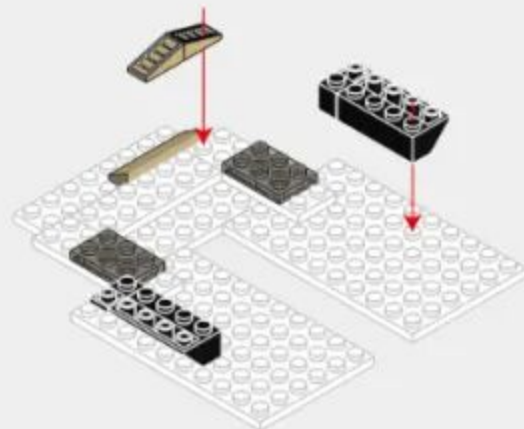

3

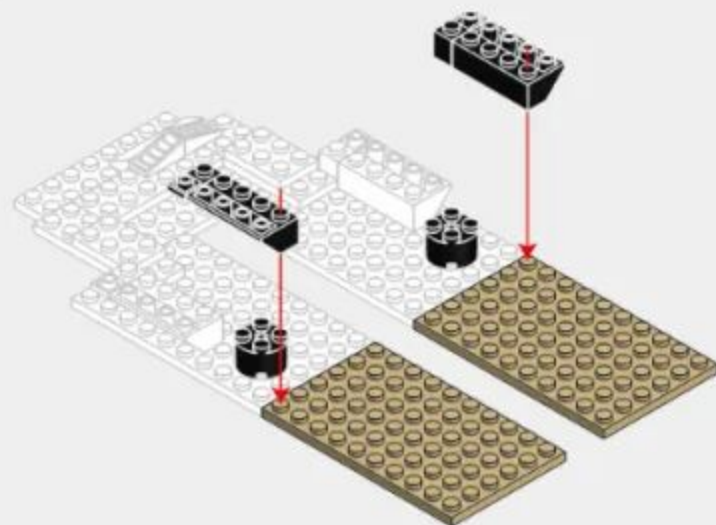

9-2

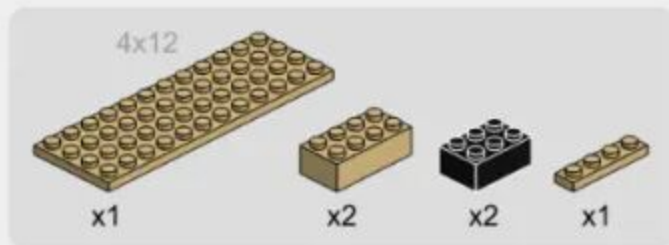

9-3

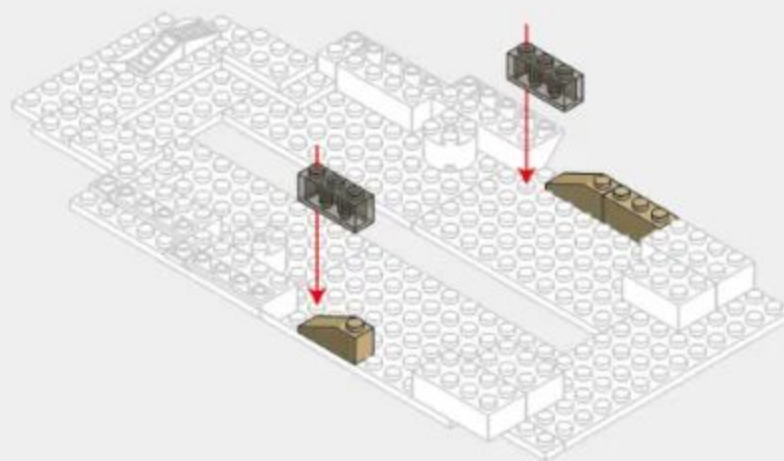
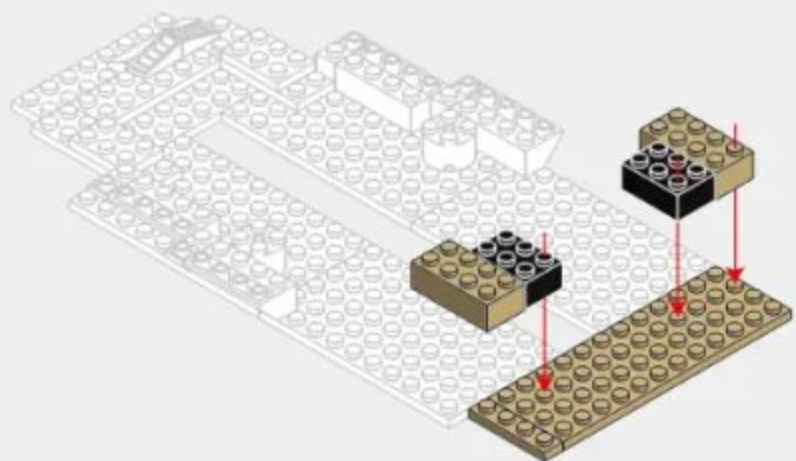

9-4

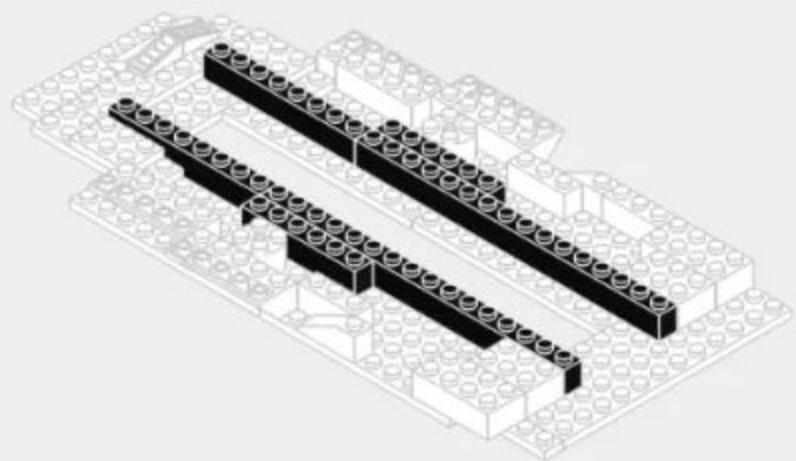
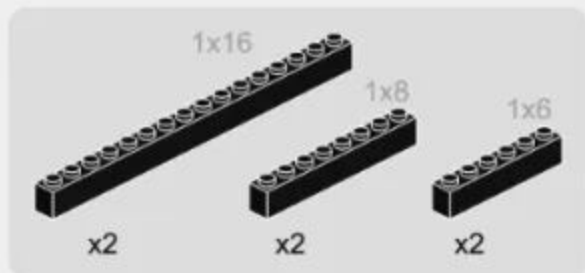

9-5

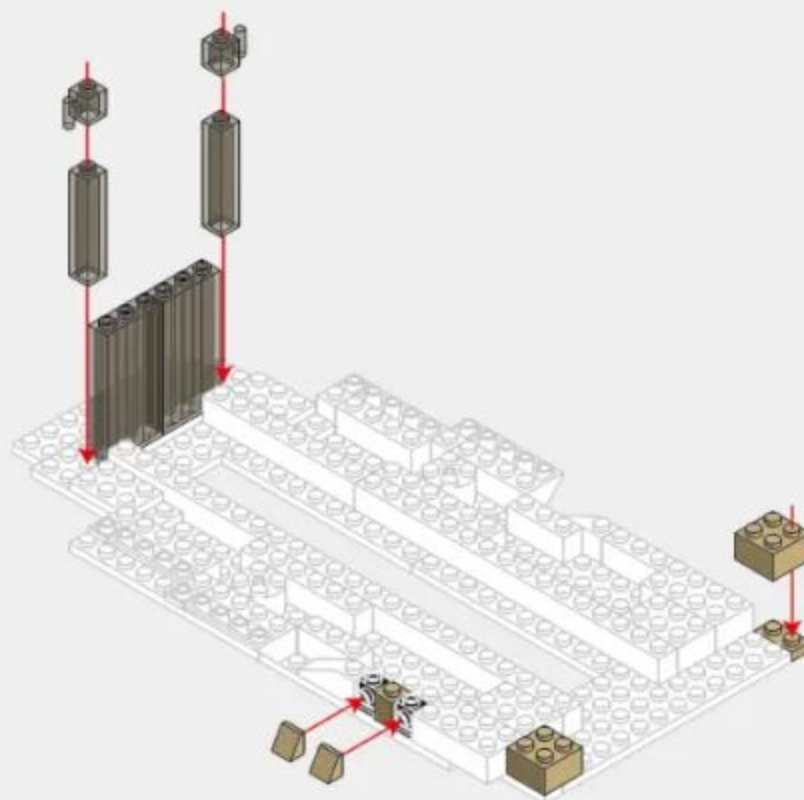

9-6

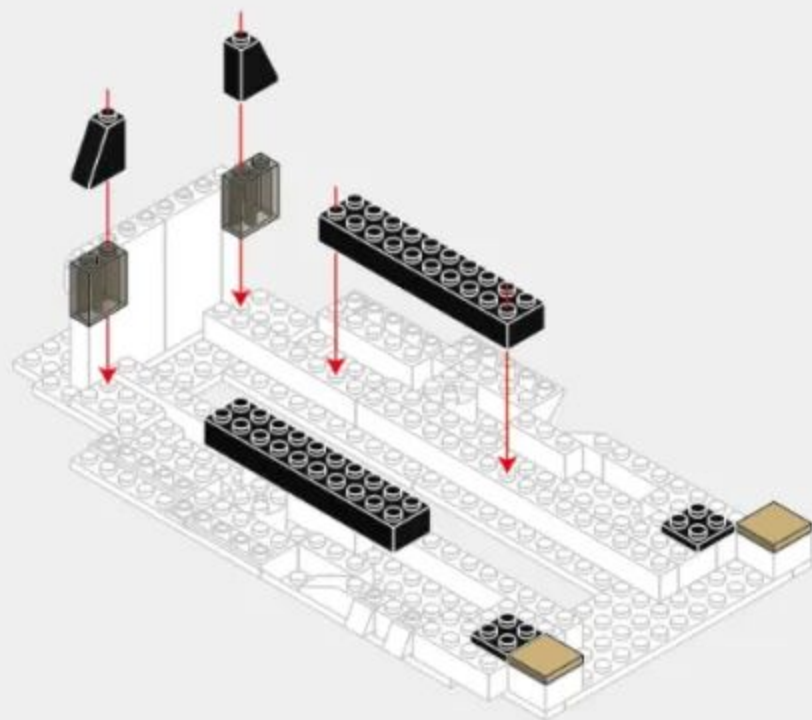

9-7

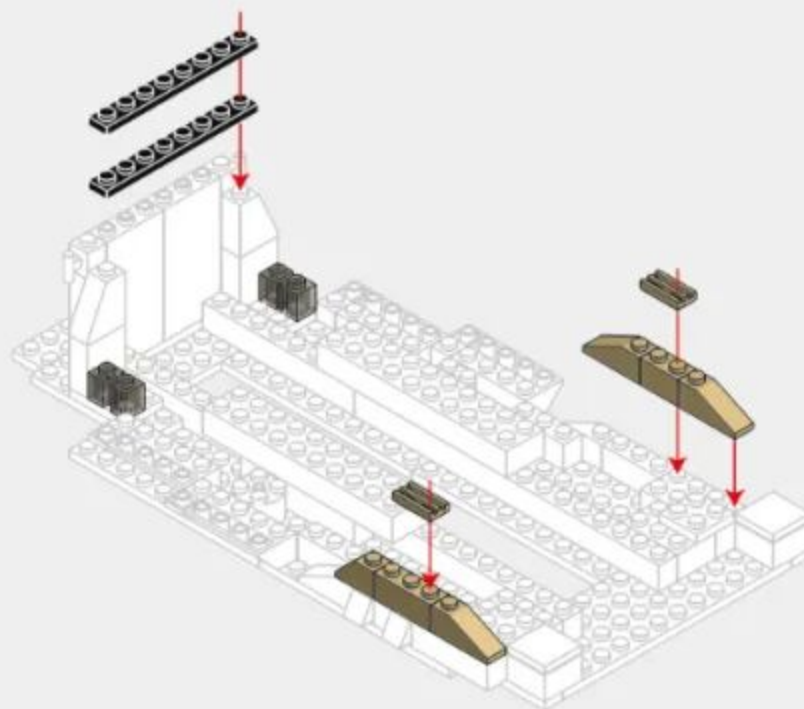

9-8

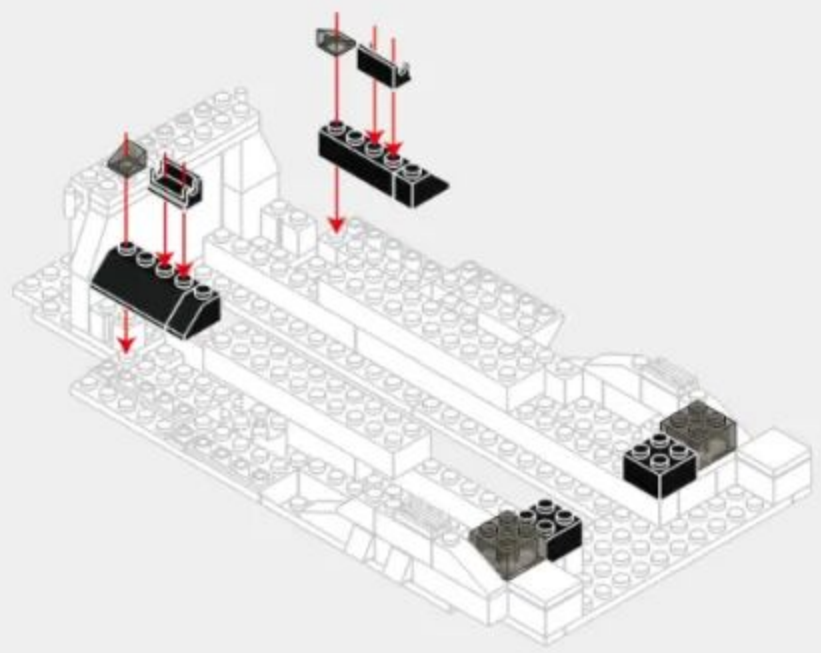
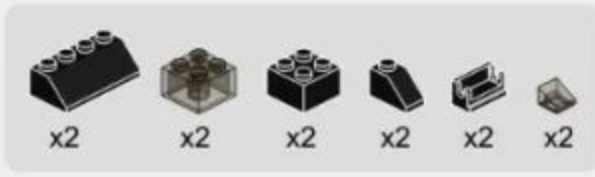

9-9

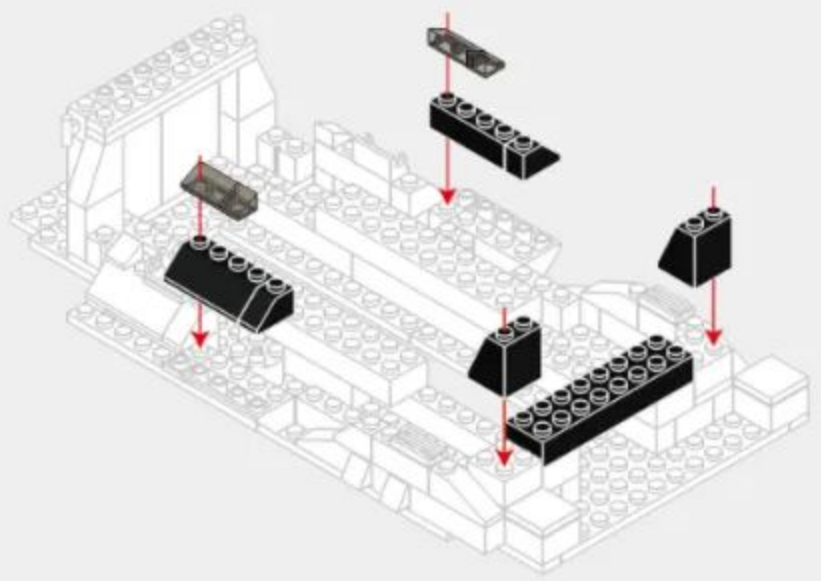

9-10



9-11

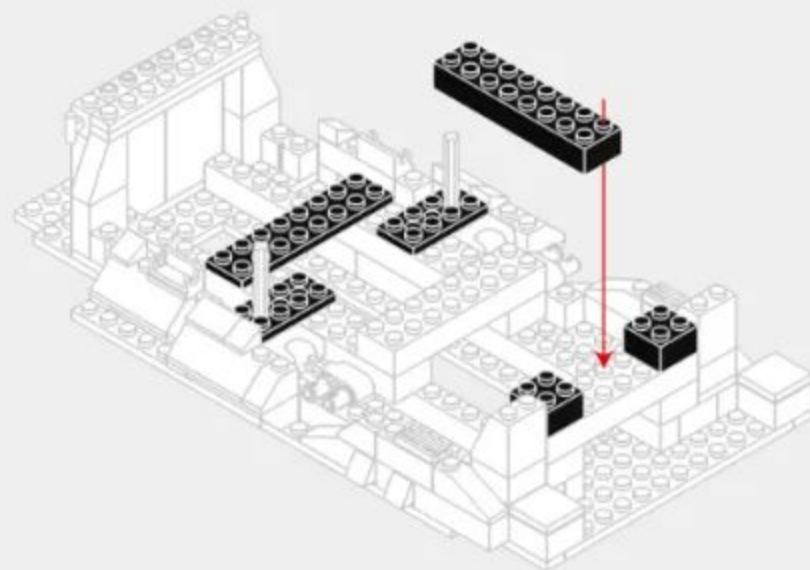
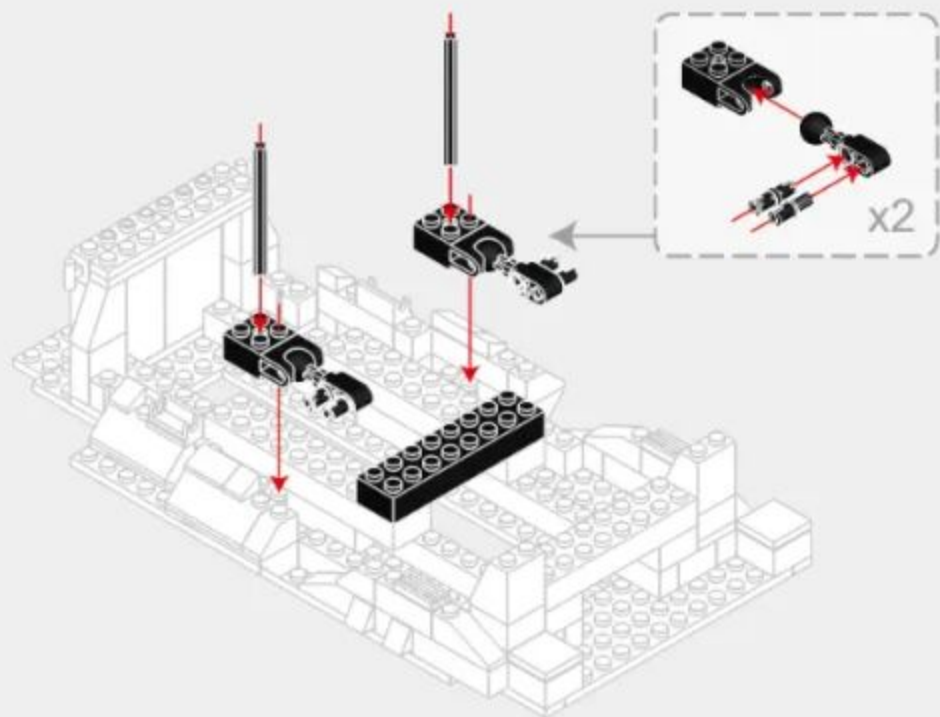
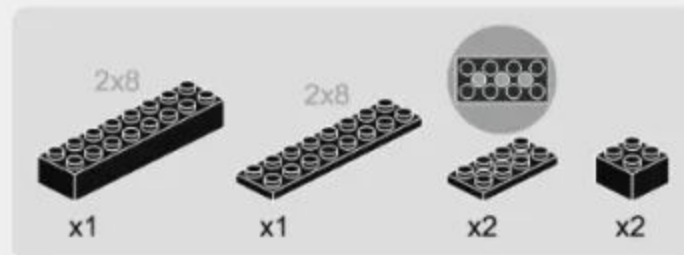

9-12



9-13

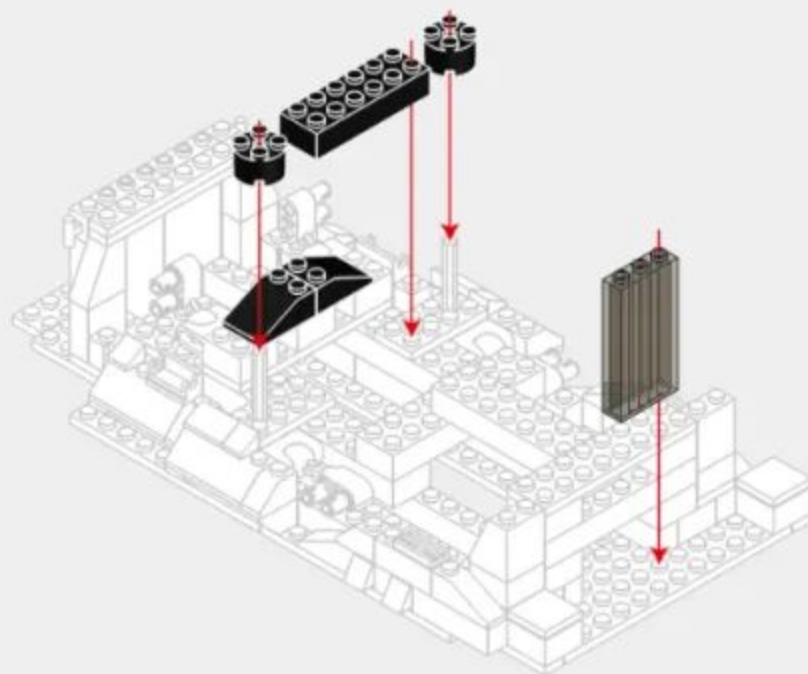
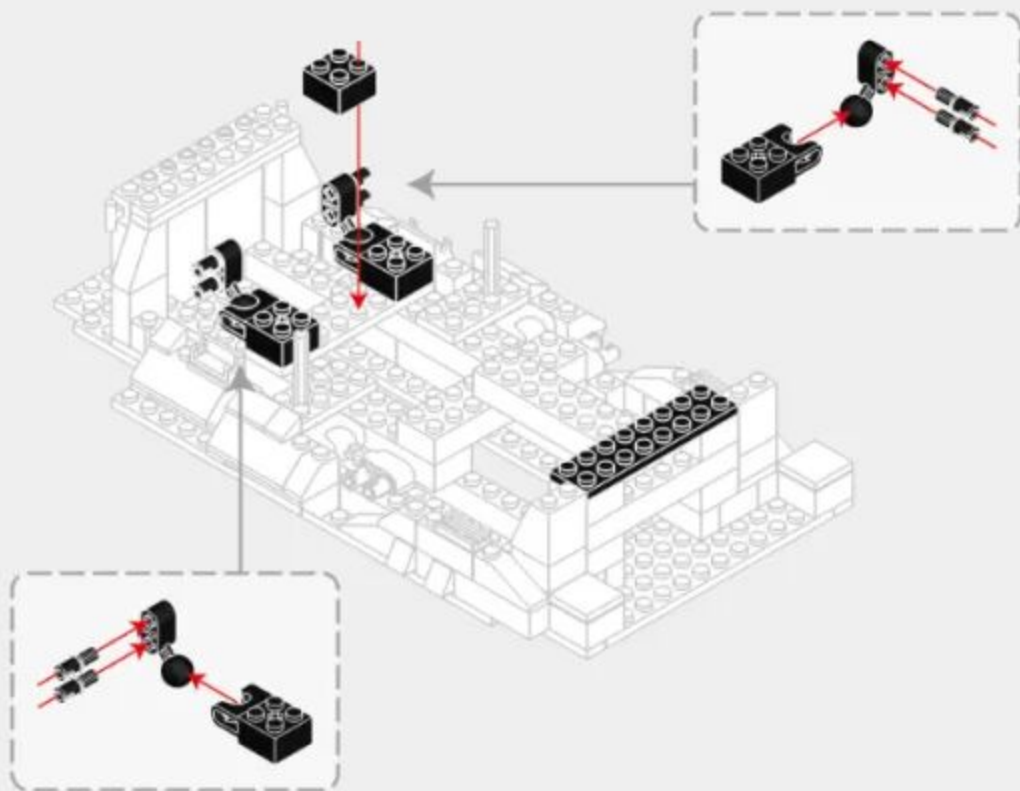
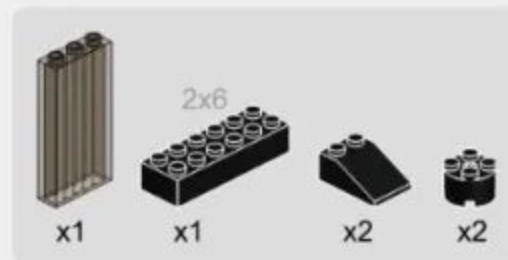

9-14

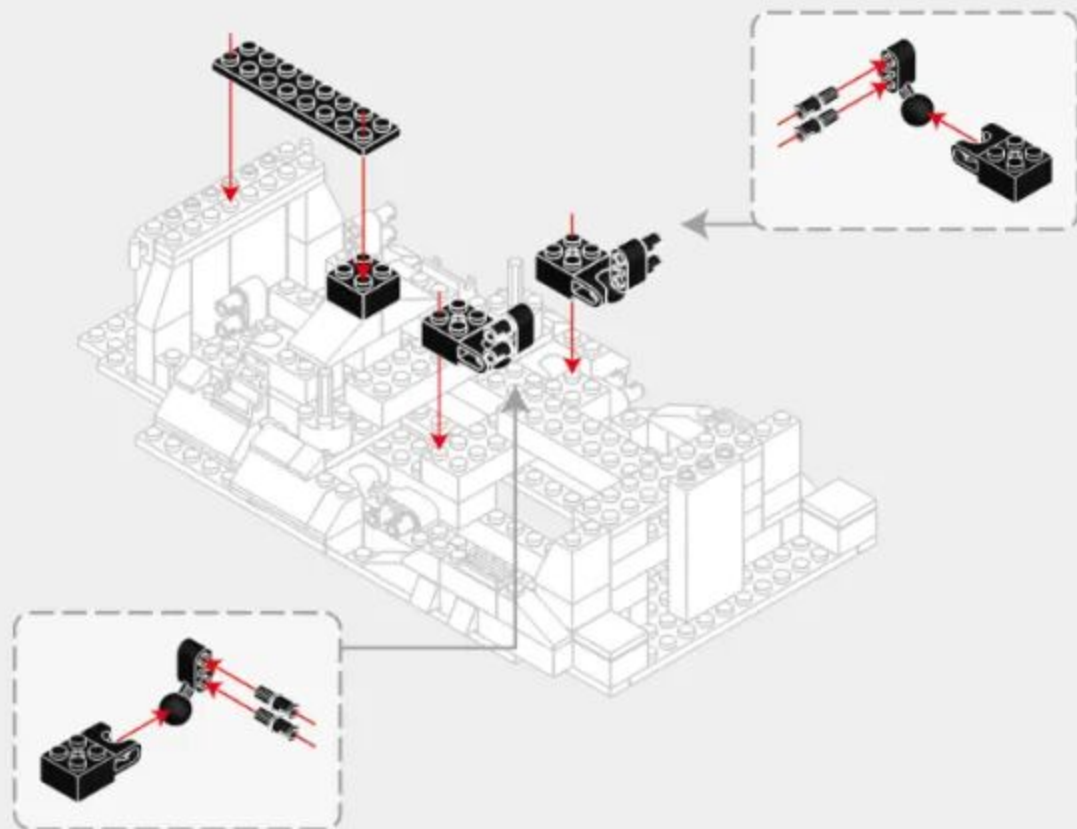

9-15

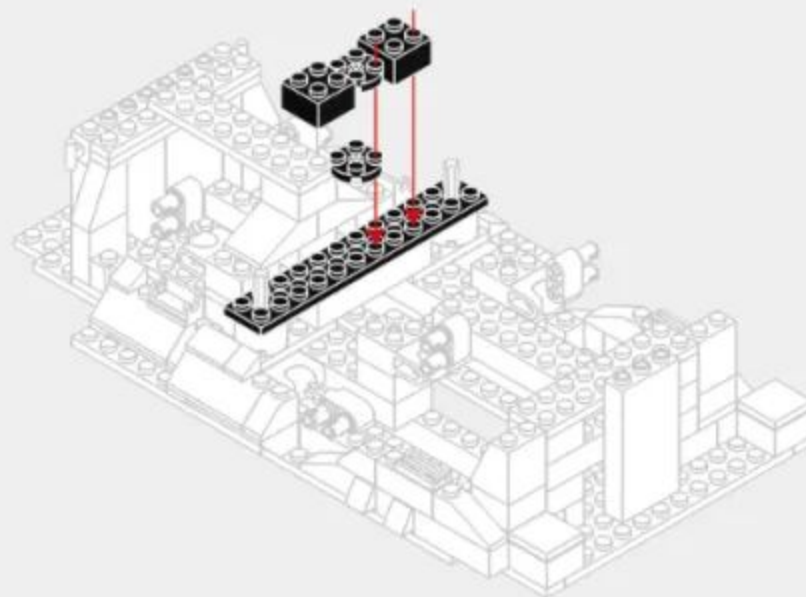
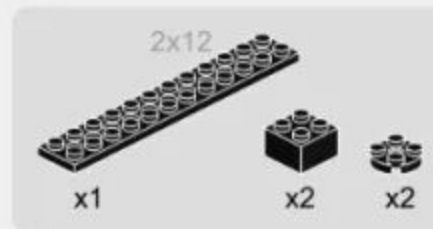

9-16

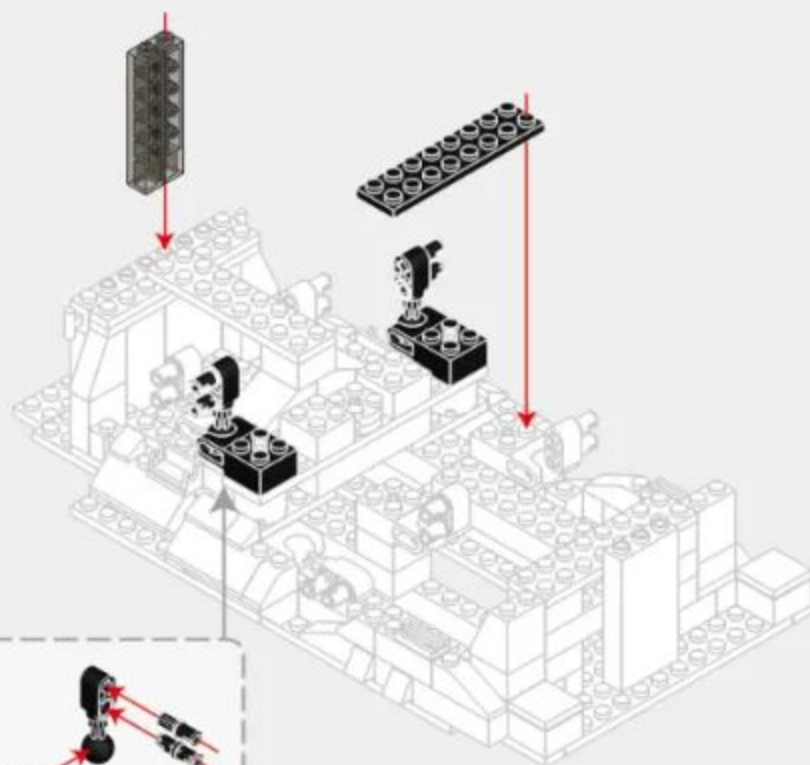

9-17

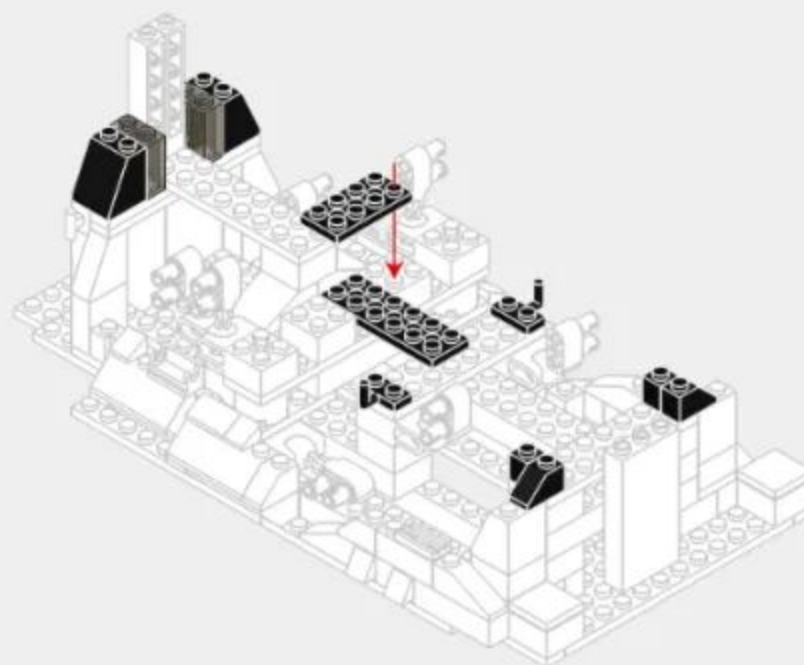
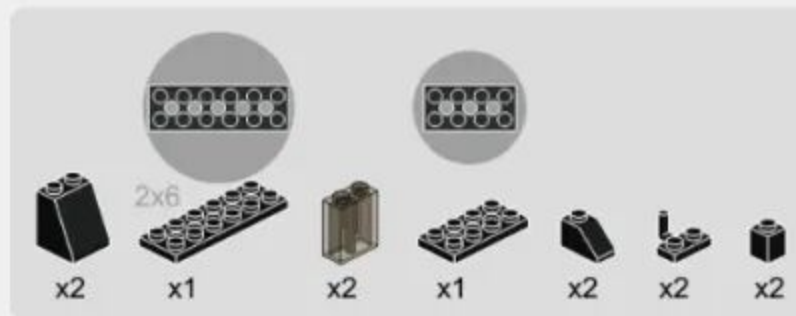

9-18

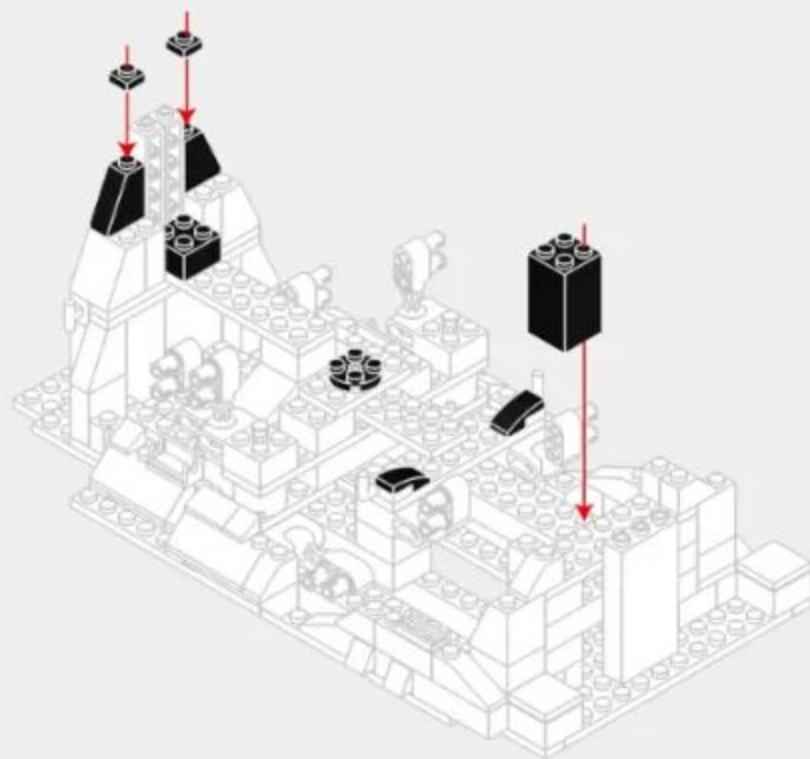

9-19

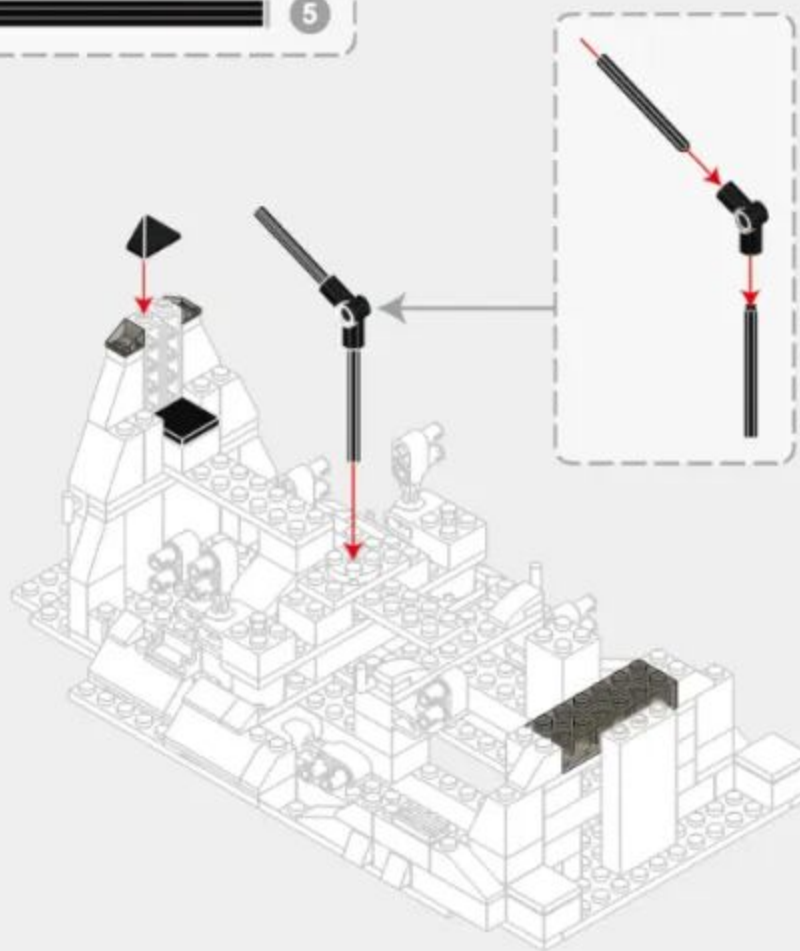

9-20

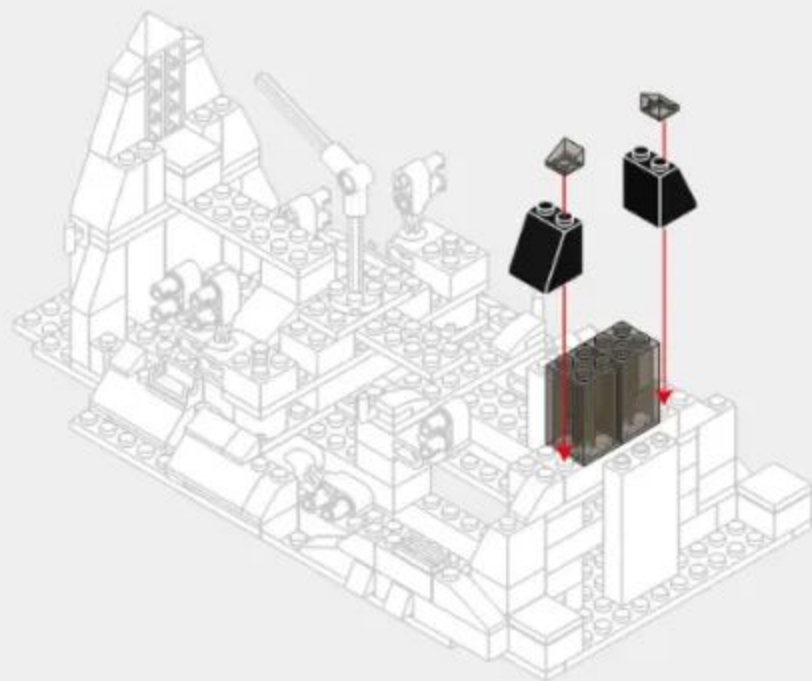

9-21

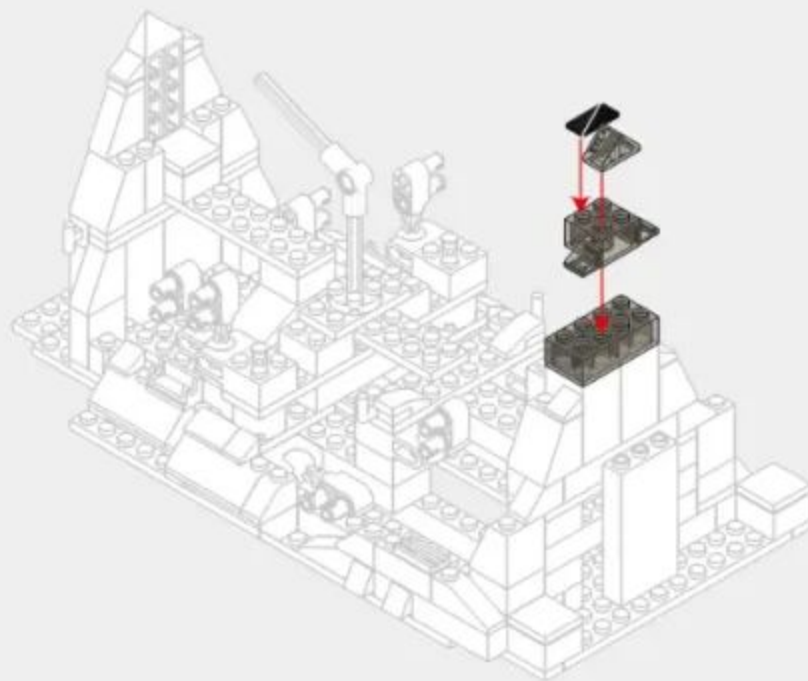

9-22

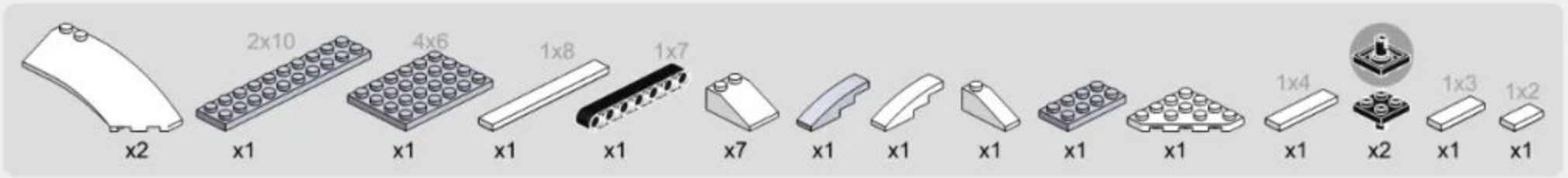

1

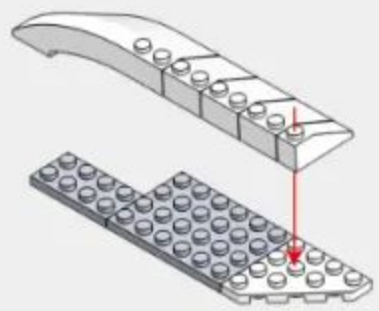

2

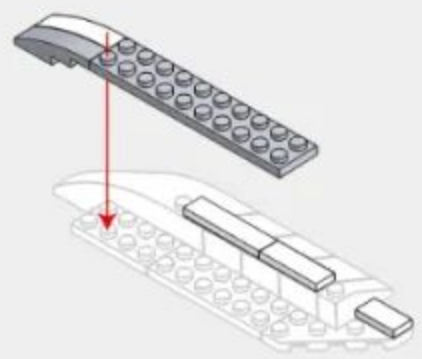

3

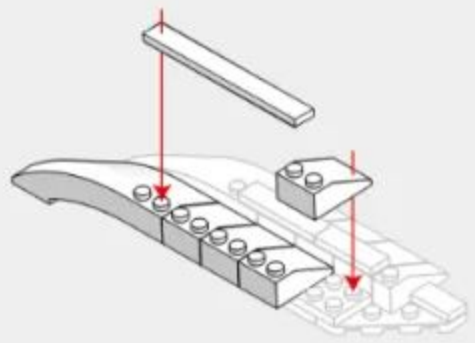

4

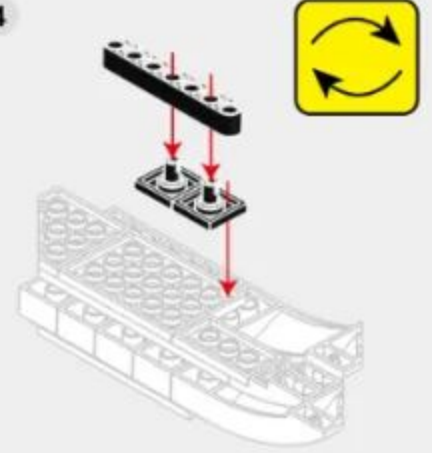

9-23

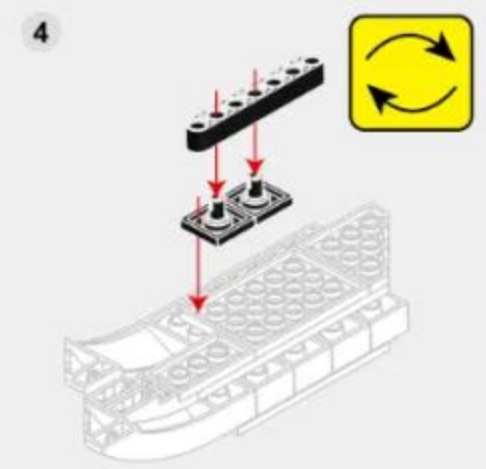
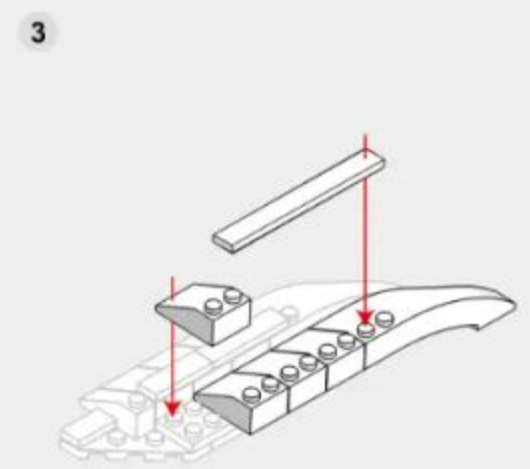
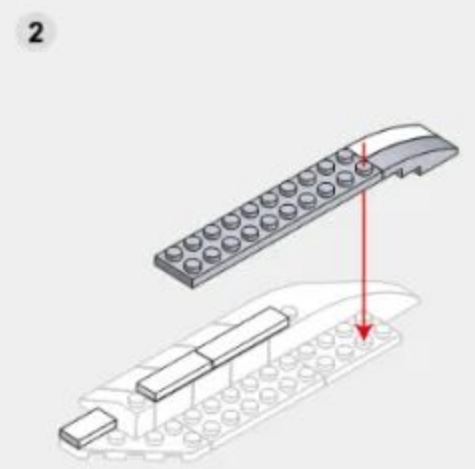
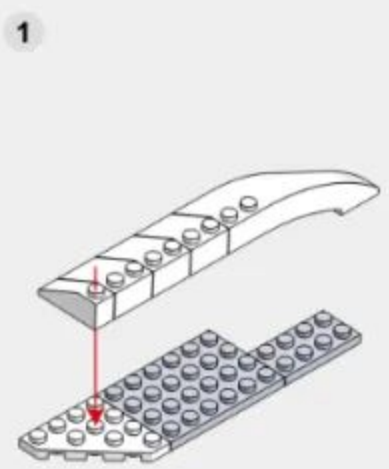
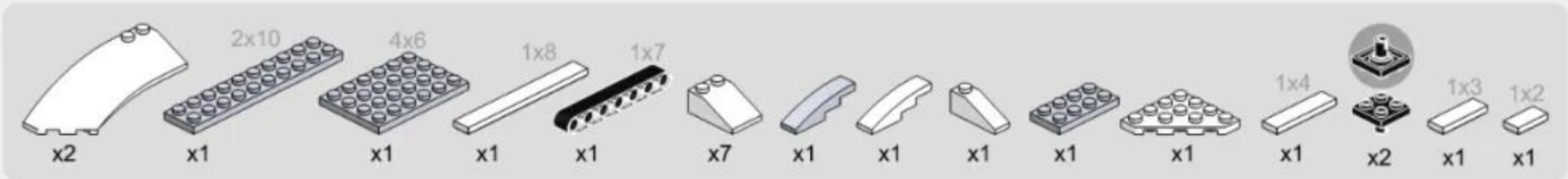

9-24

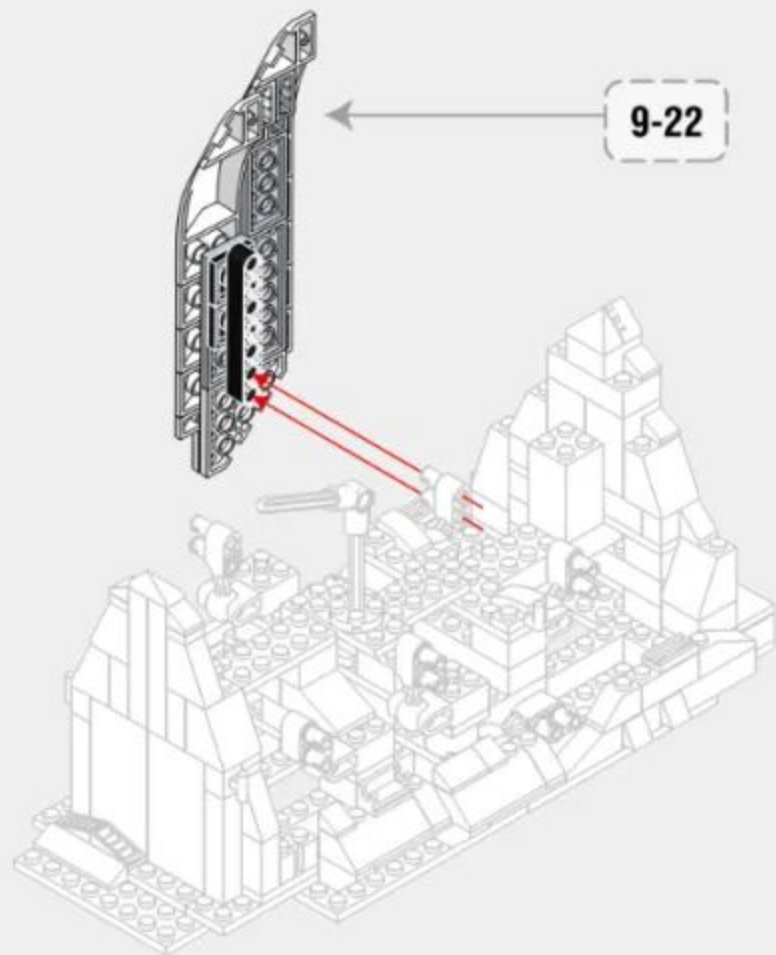

9-25

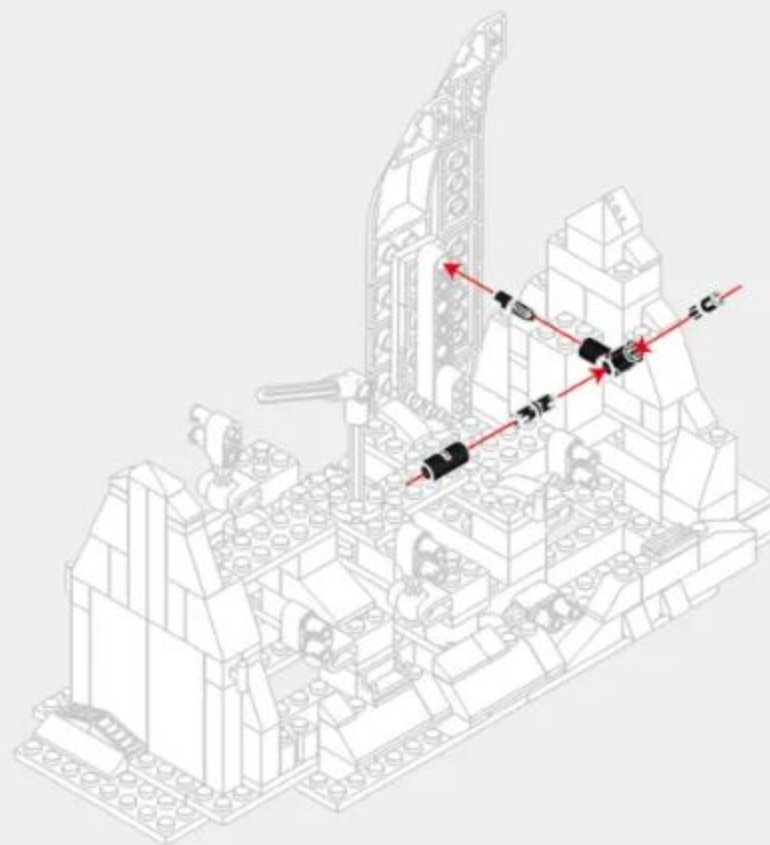

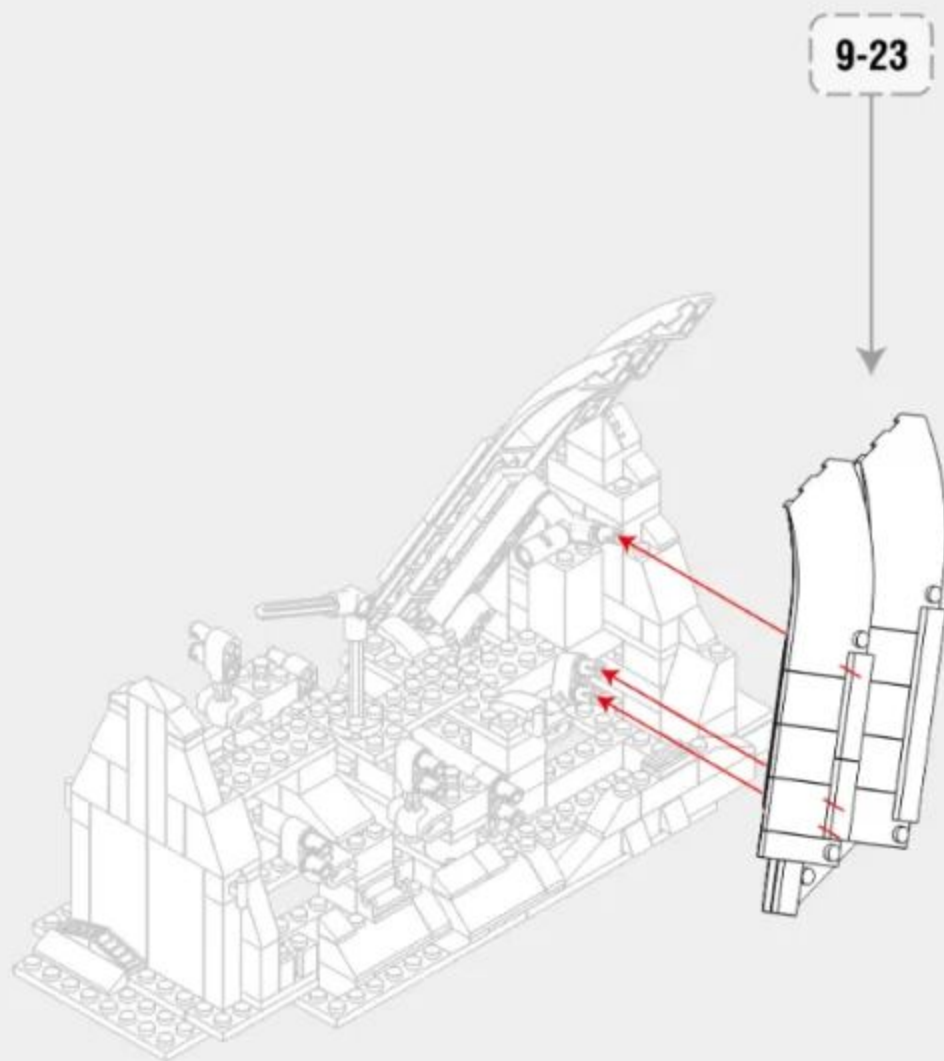

**10**  
**PACK**

**286**PCS

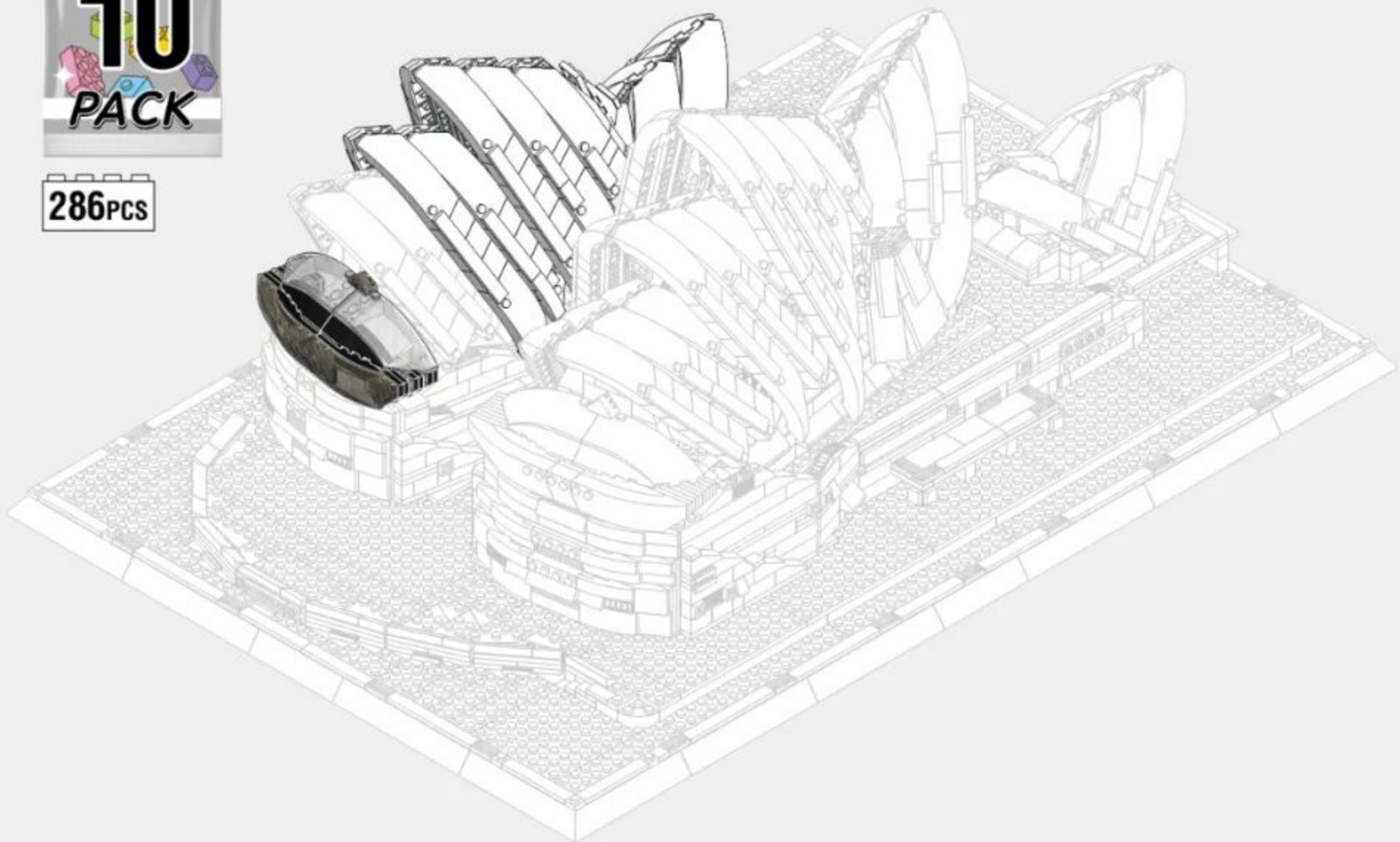

**205**

# 10-1

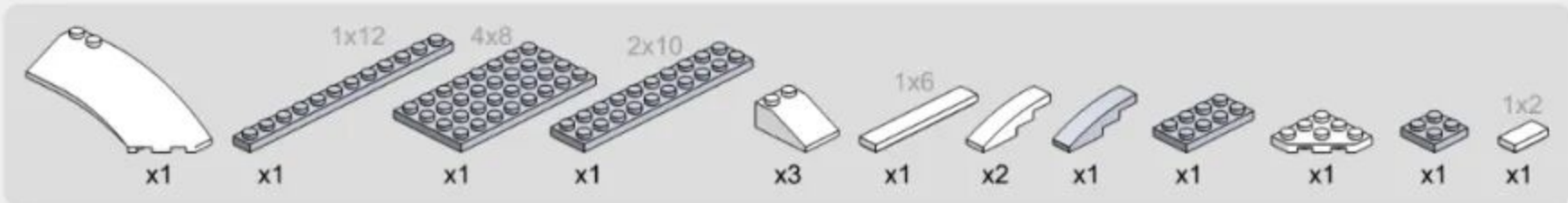

1

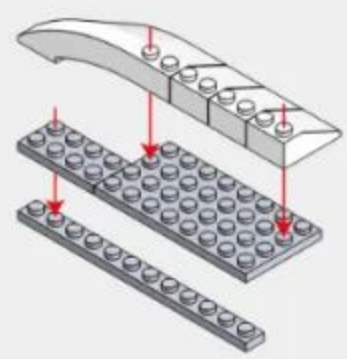

2

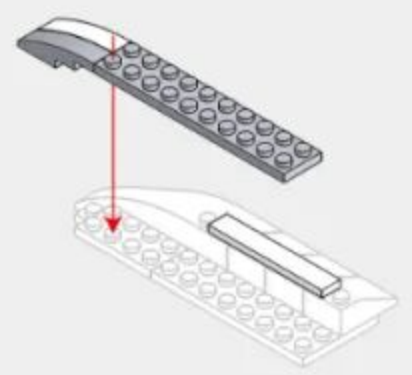

3

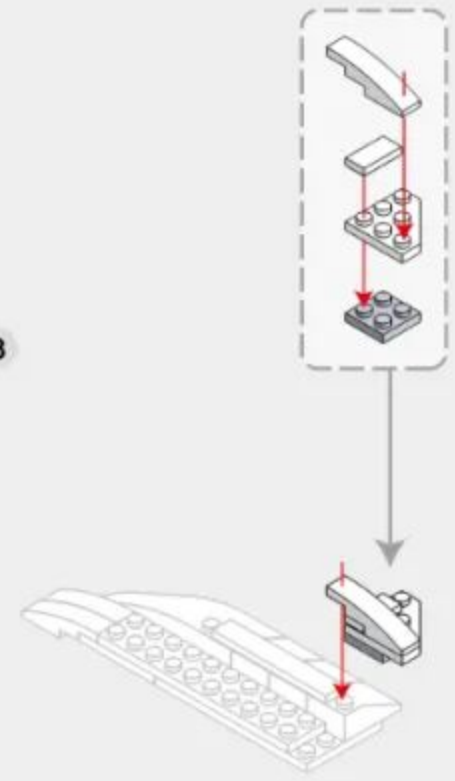

# 10-2

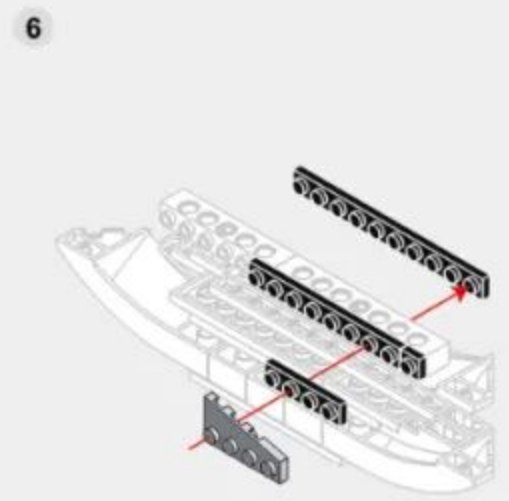
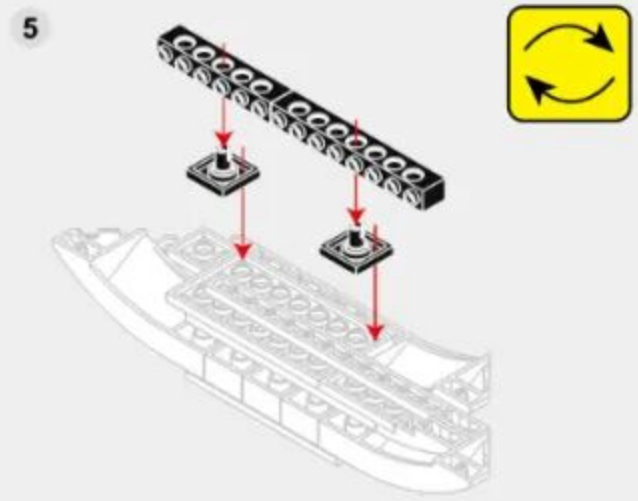
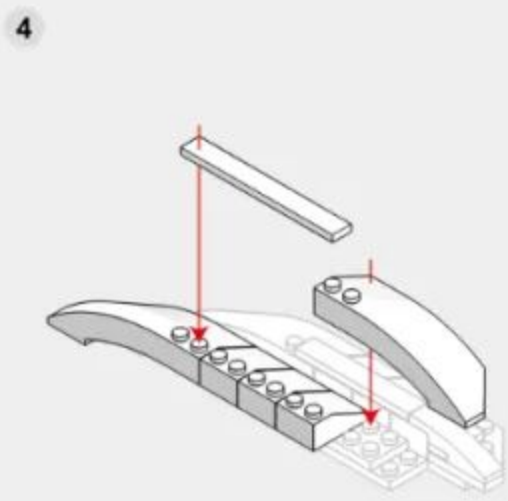
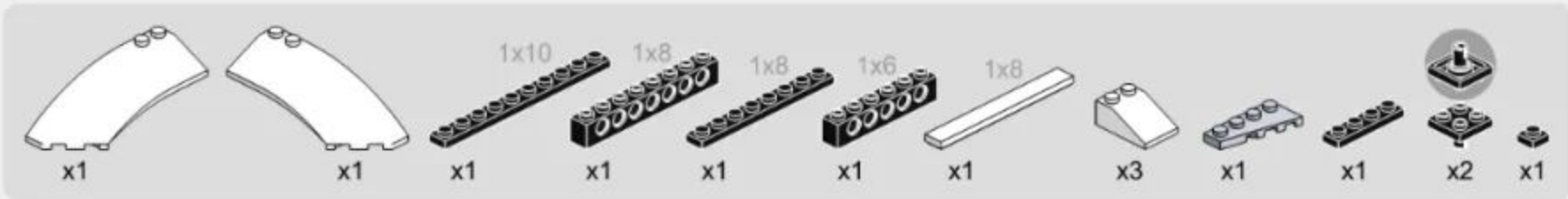

# 10-3

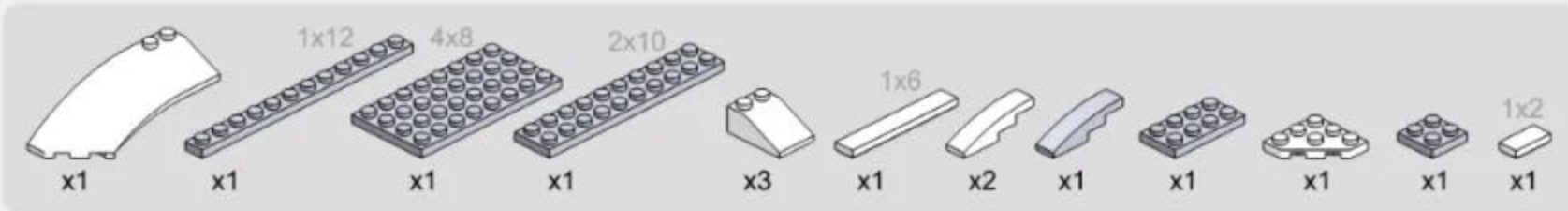

1

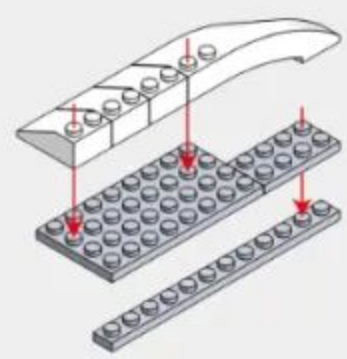

2

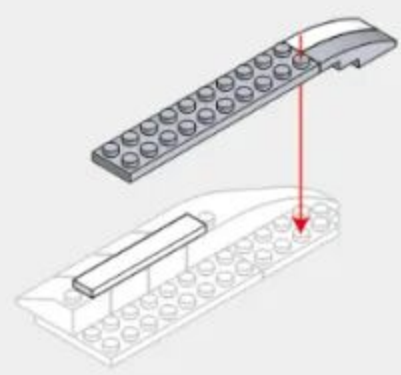

3

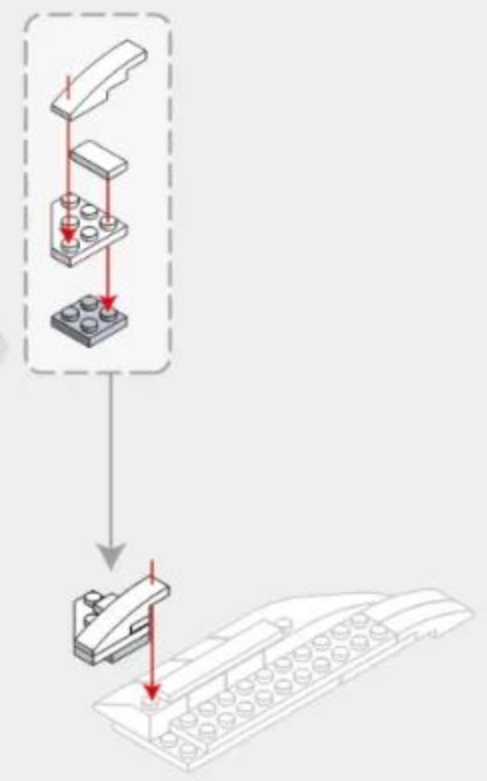



10-5

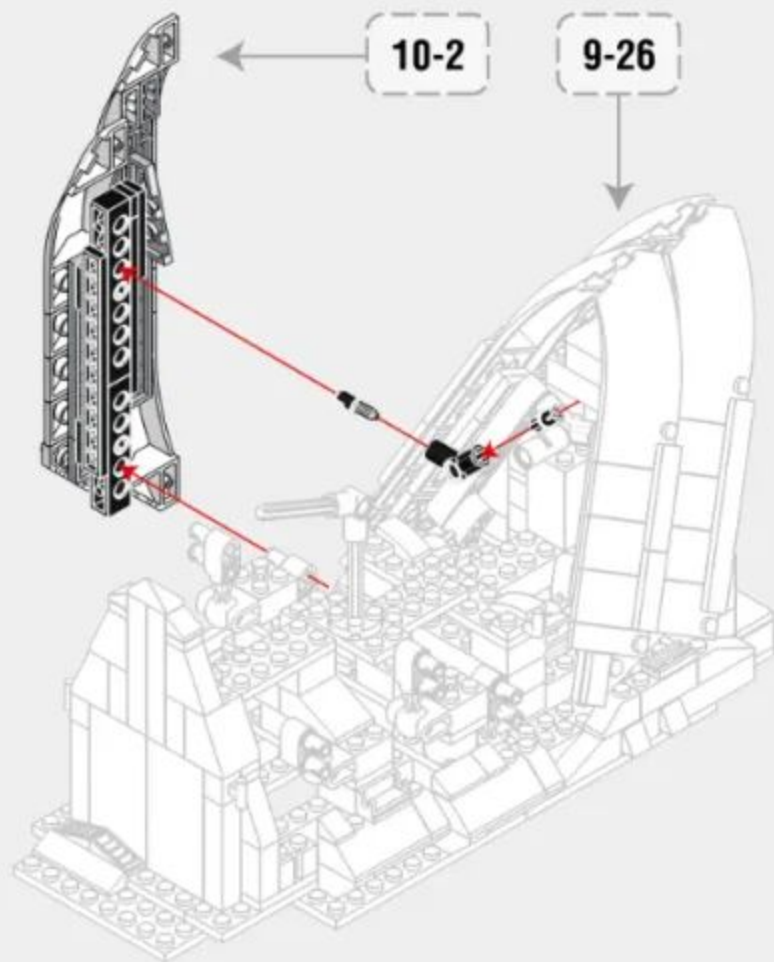

10-6

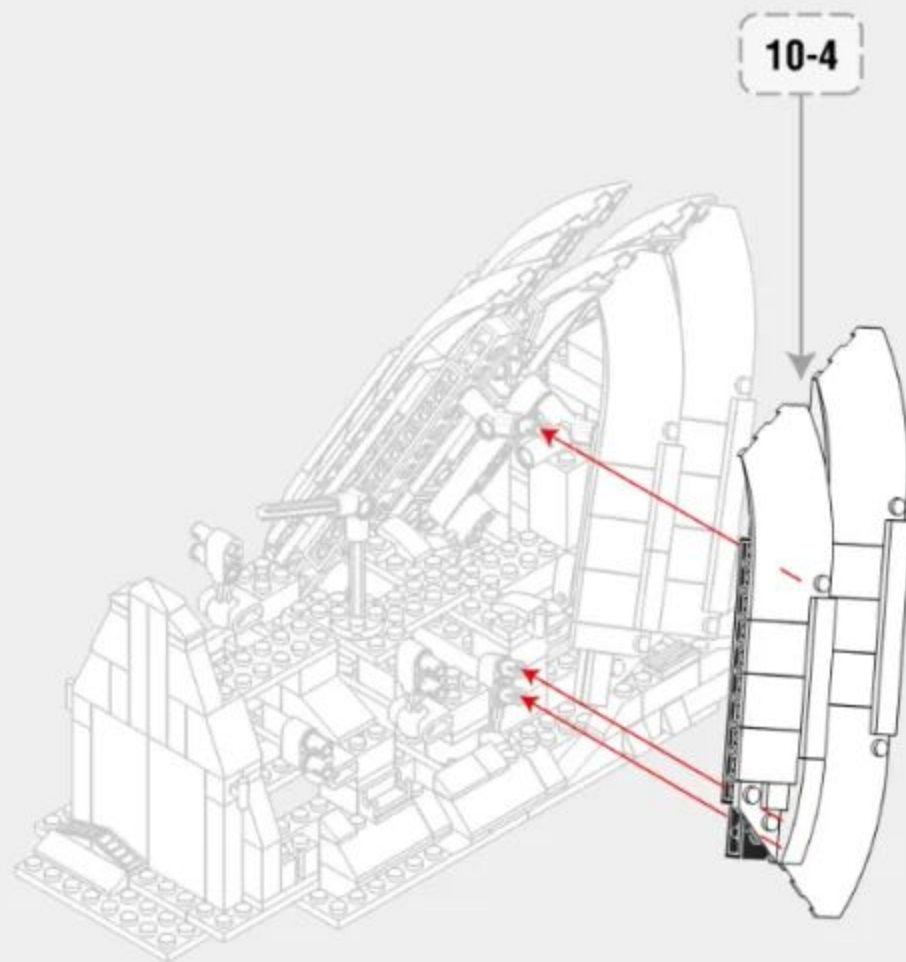

### 10-7

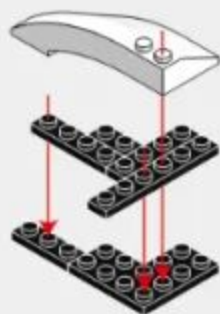
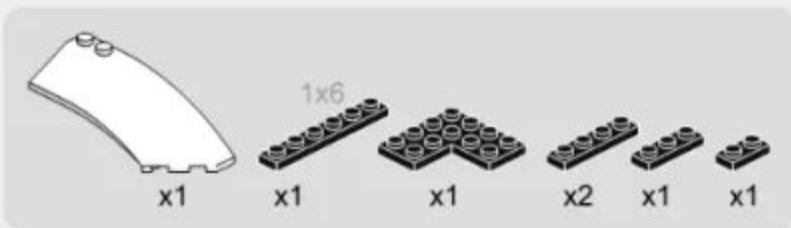

### 10-8



### 10-9

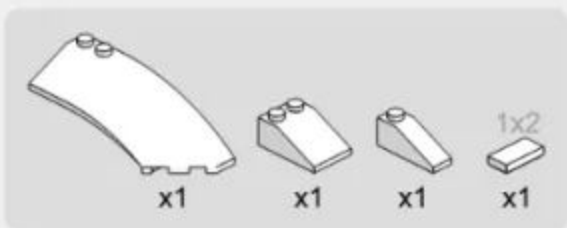

### 10-10

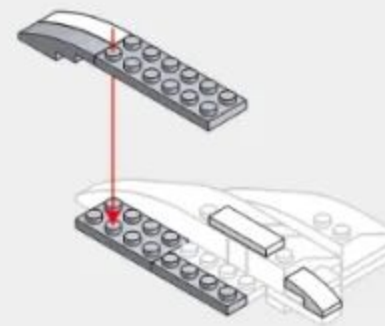

10-11

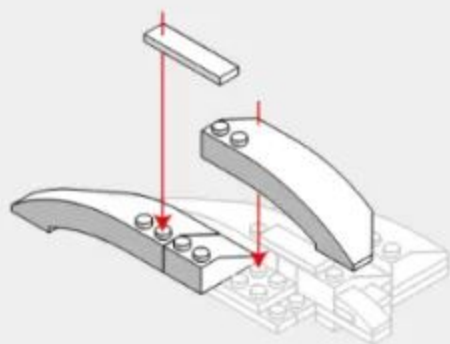
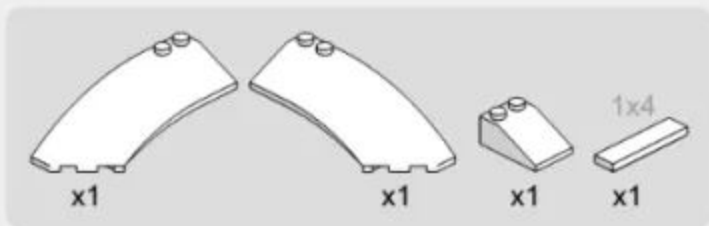

10-12

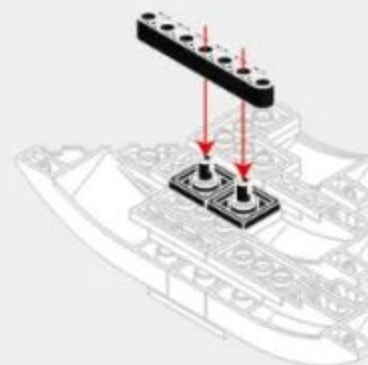

10-13

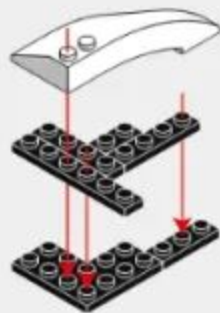
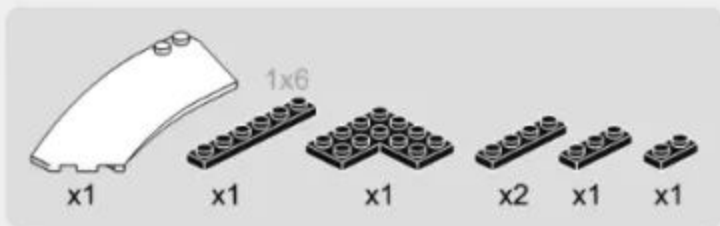

10-14

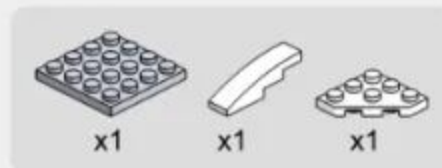

### 10-15

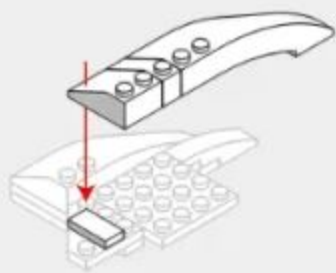
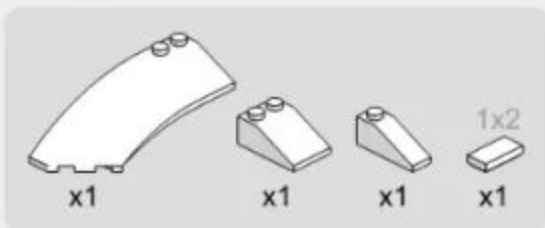

### 10-16

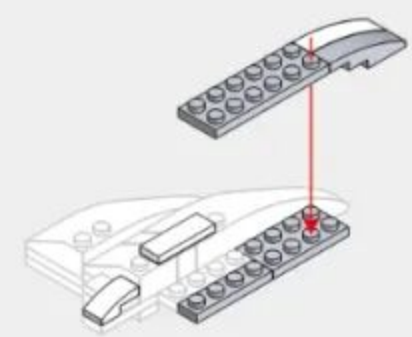
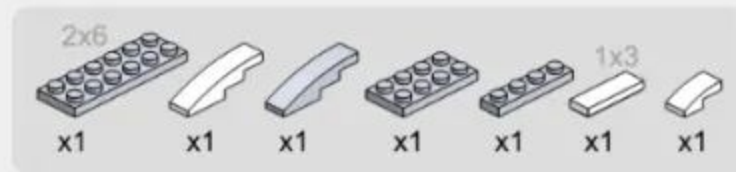

### 10-17

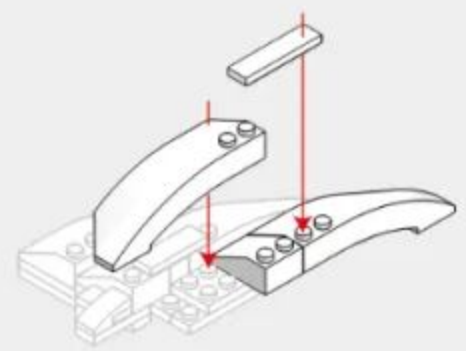
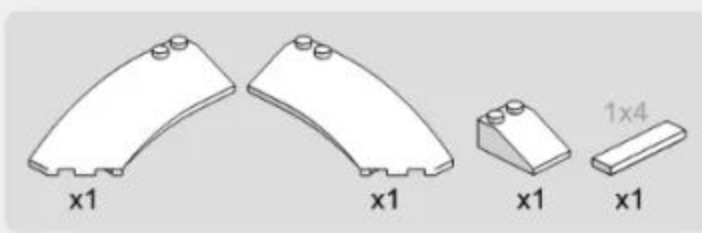

### 10-18

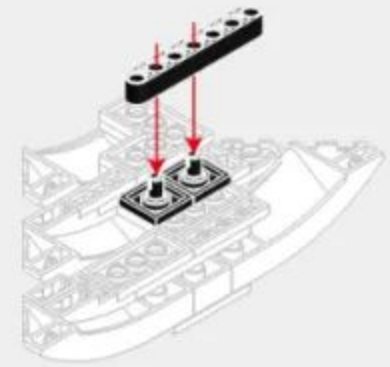

10-19



10-12

10-6

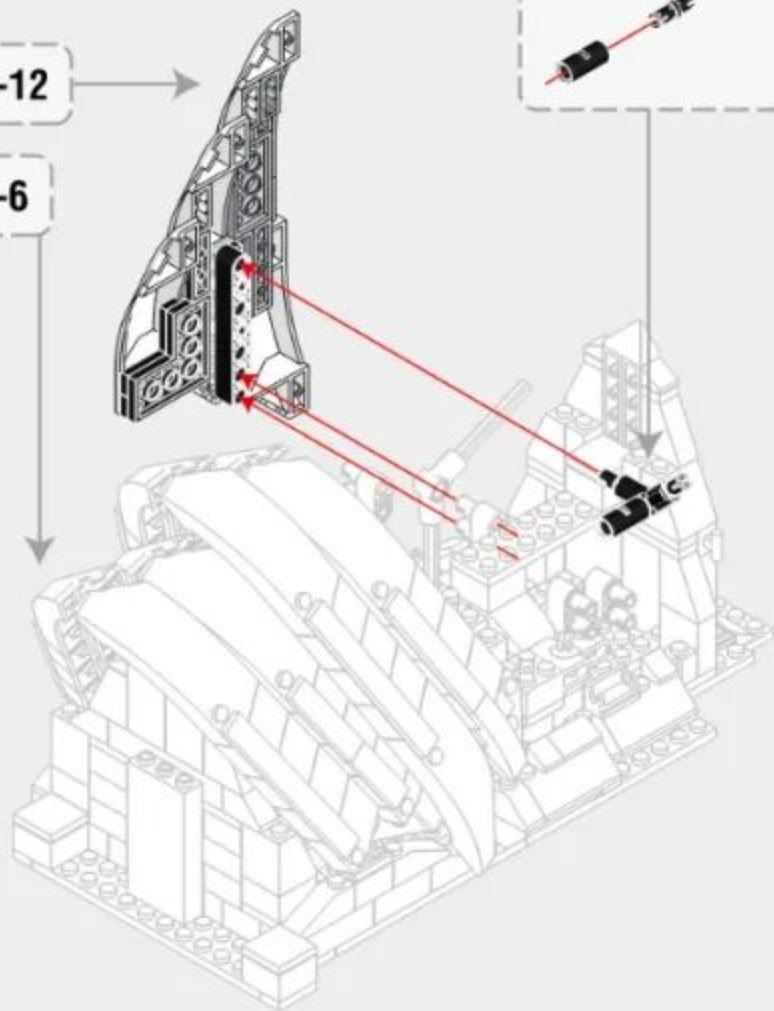

10-20

10-18

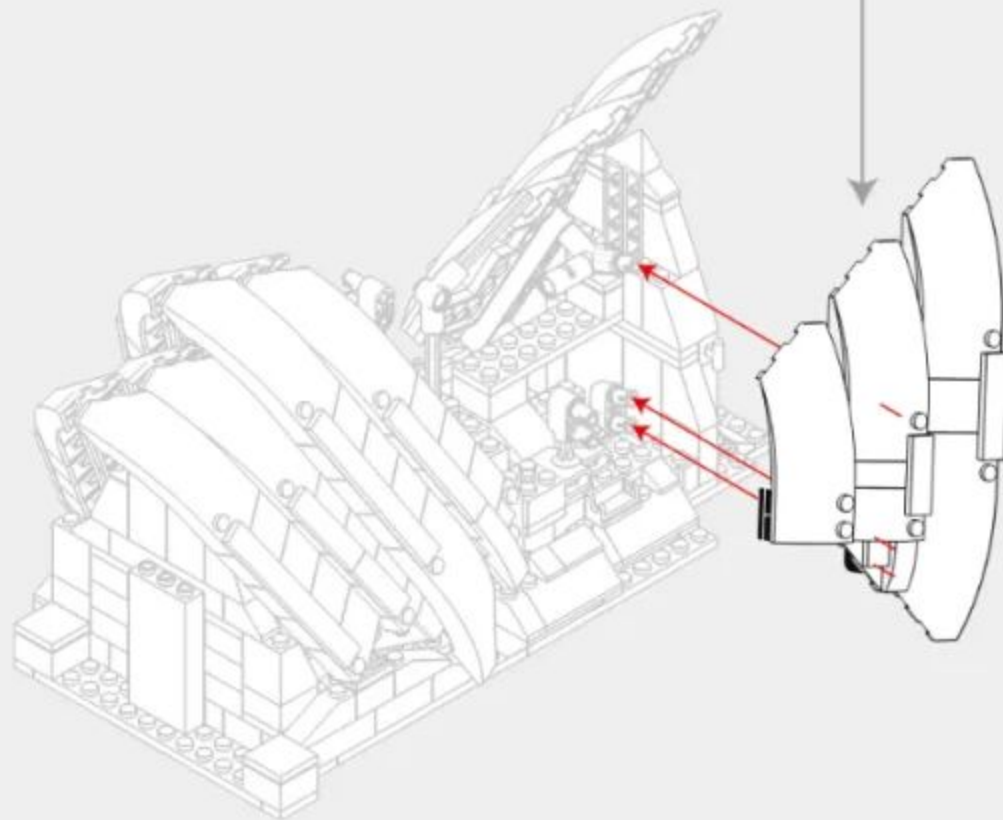

10-21

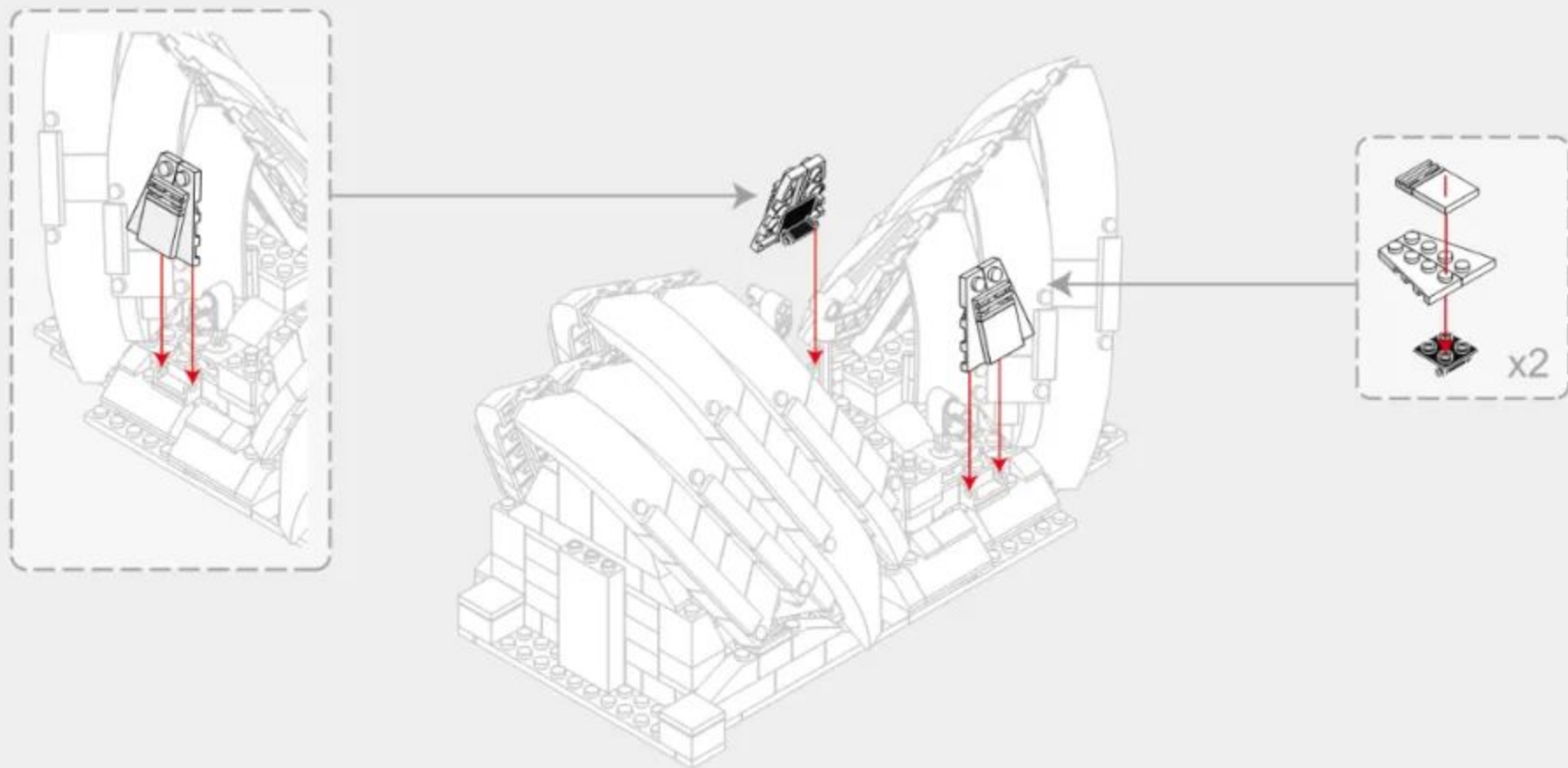

# 10-22

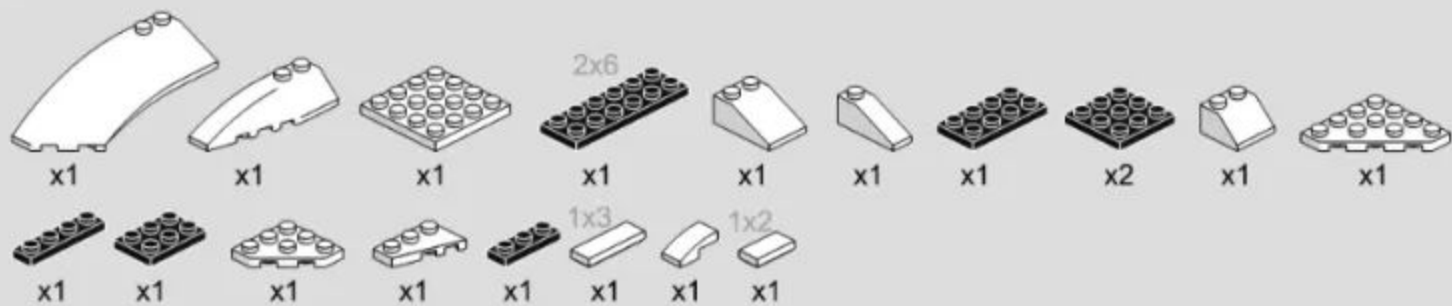

1



2



3



4

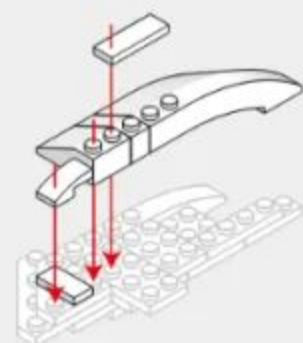

# 10-23

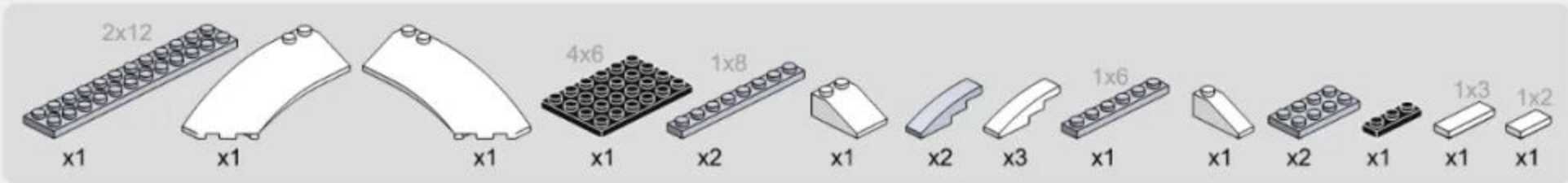

5

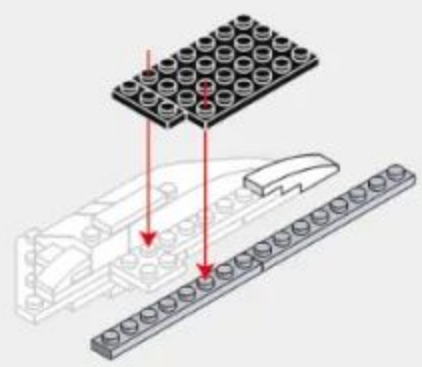

6

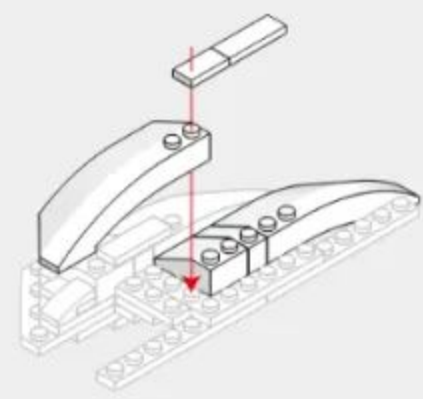

7

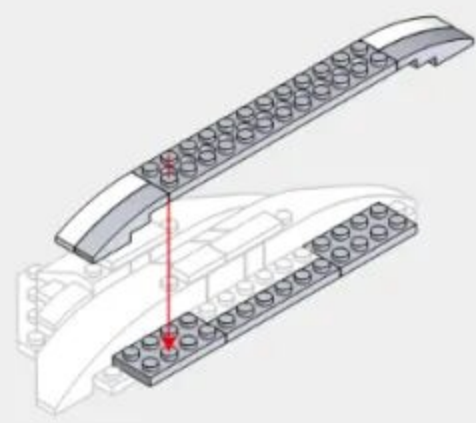

# 10-24

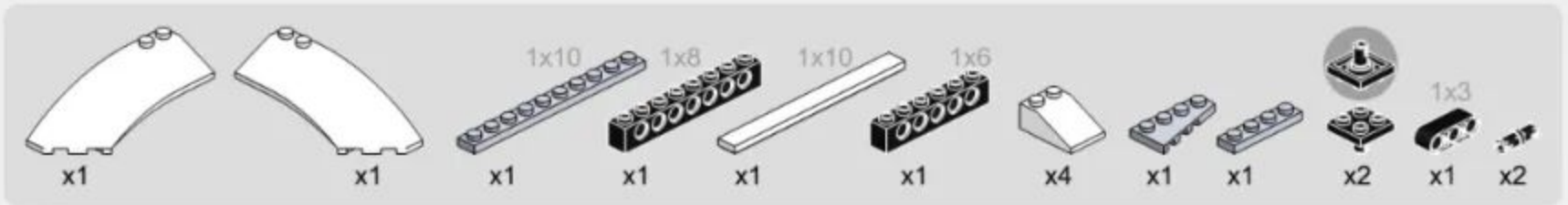

8

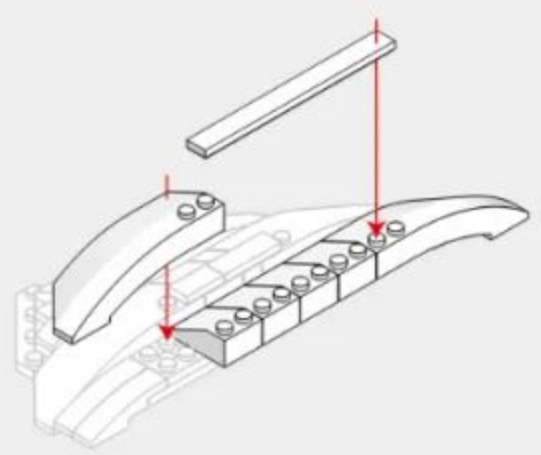

9

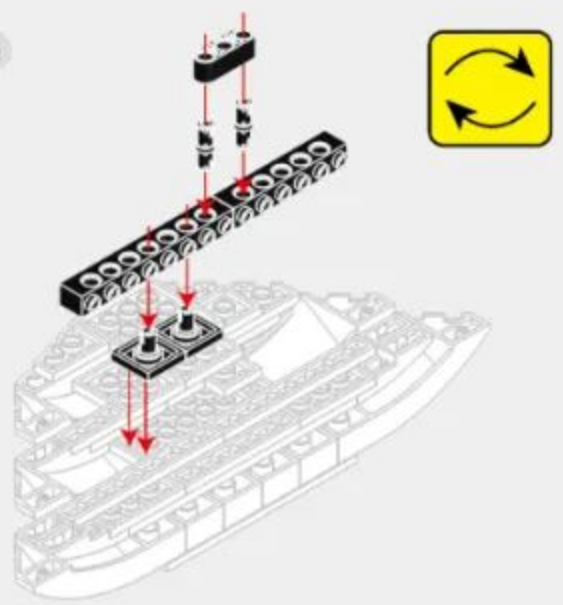

10

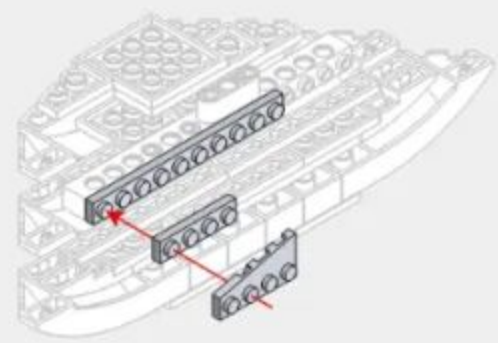

# 10-25

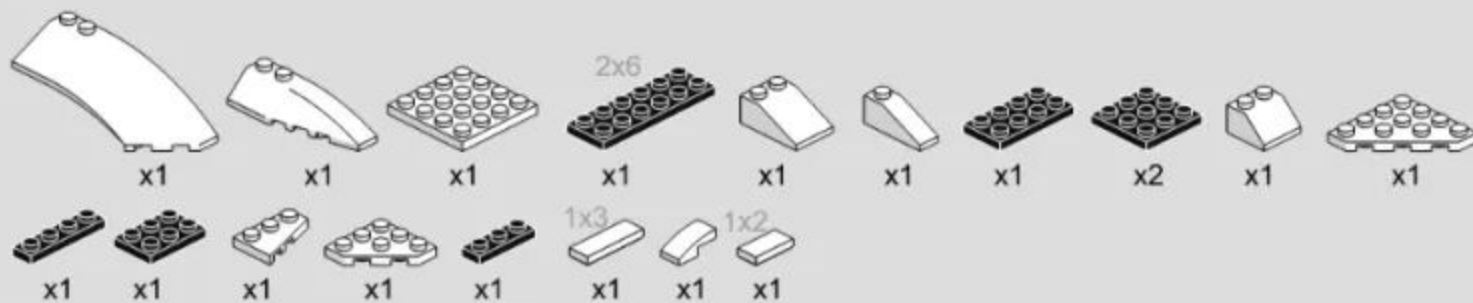

1



2

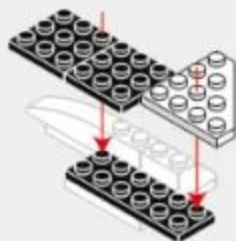

3

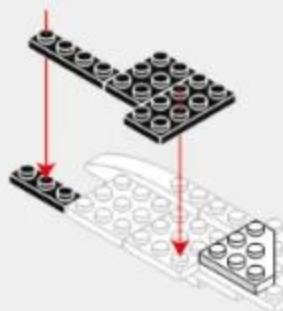

4

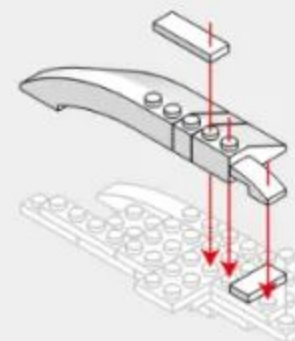

# 10-26

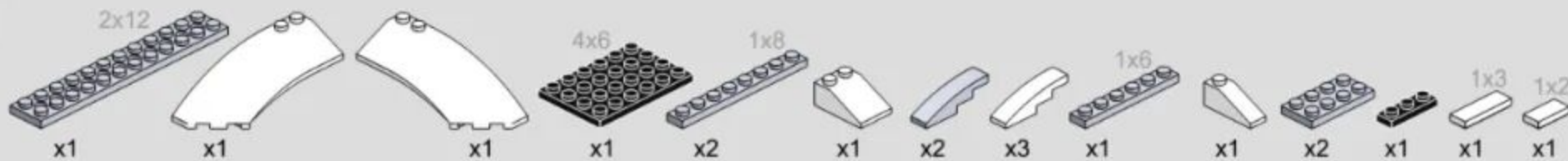

5

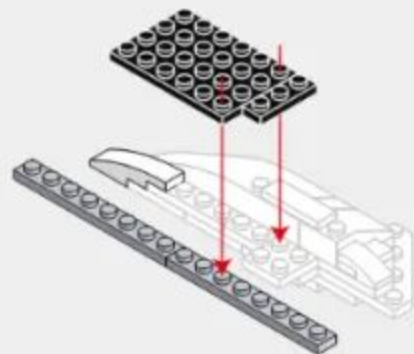

6

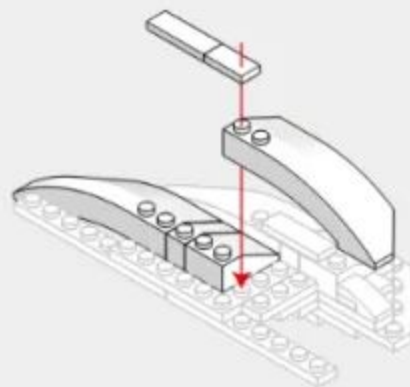

7

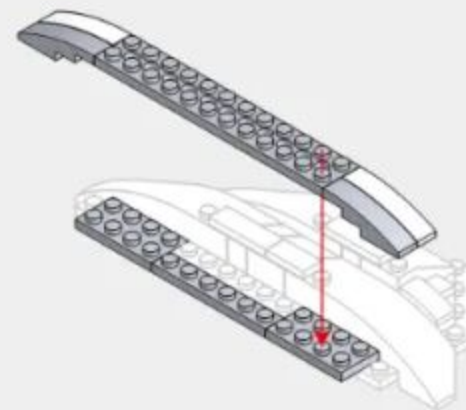

# 10-27

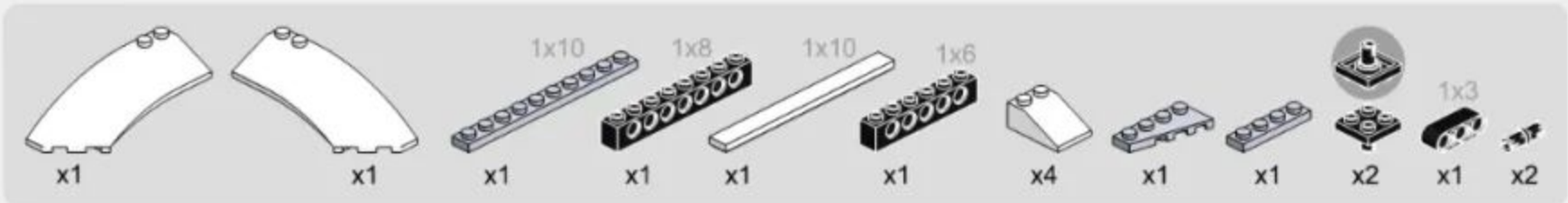

8

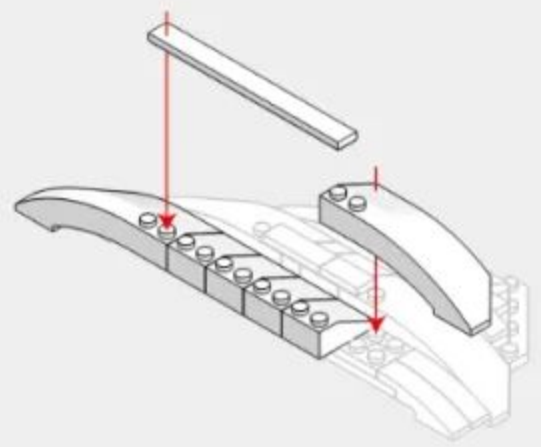

9

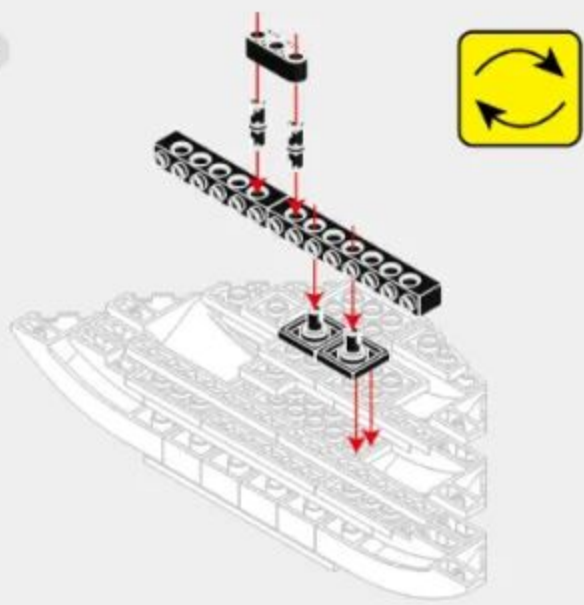

10

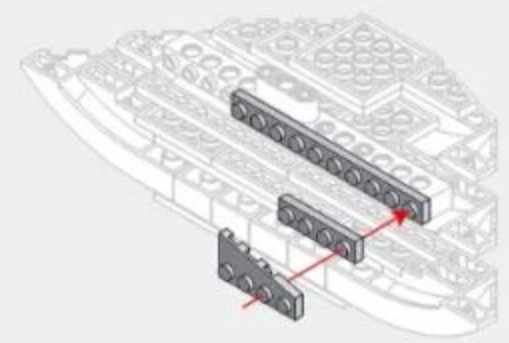

10-28

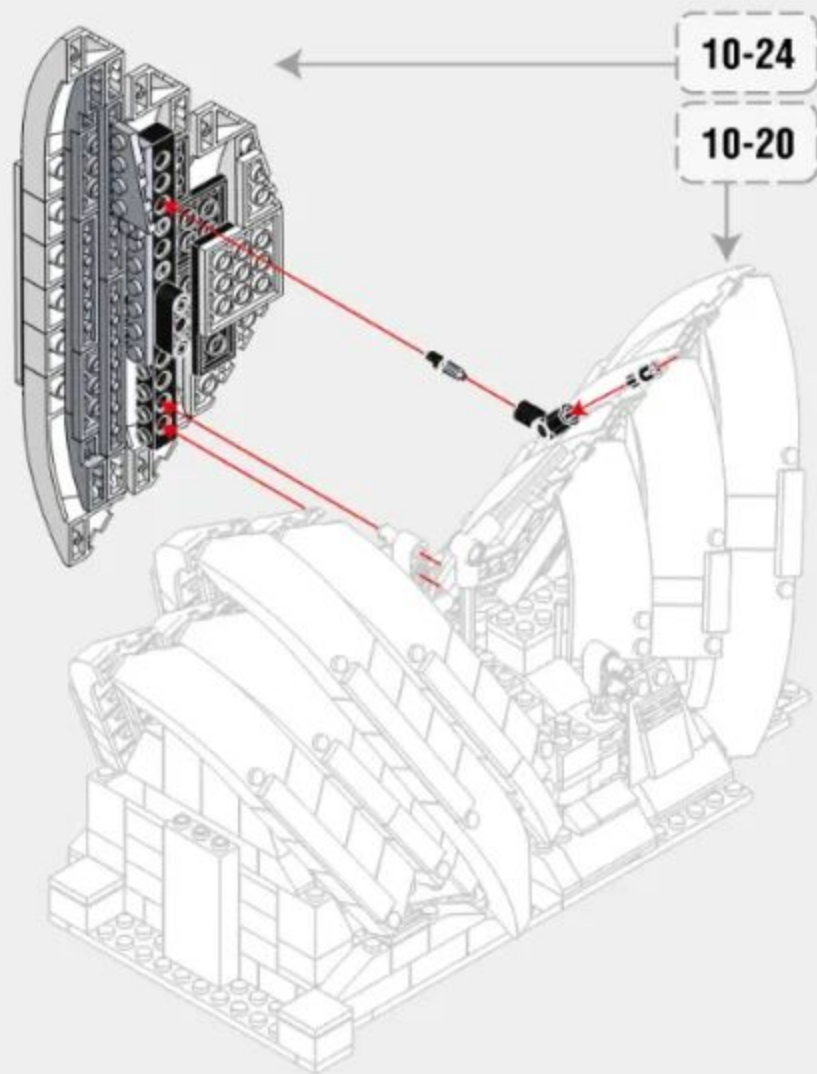

10-29

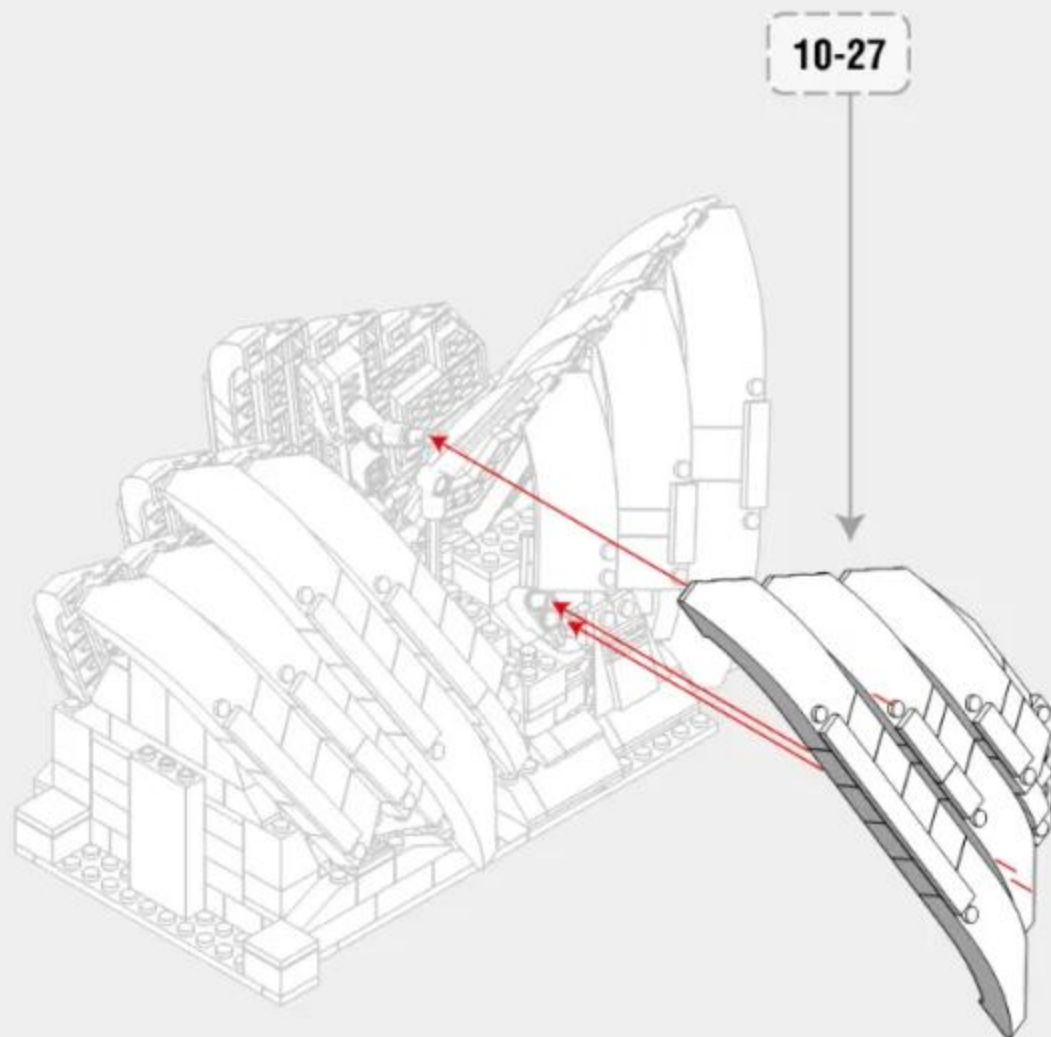

10-30

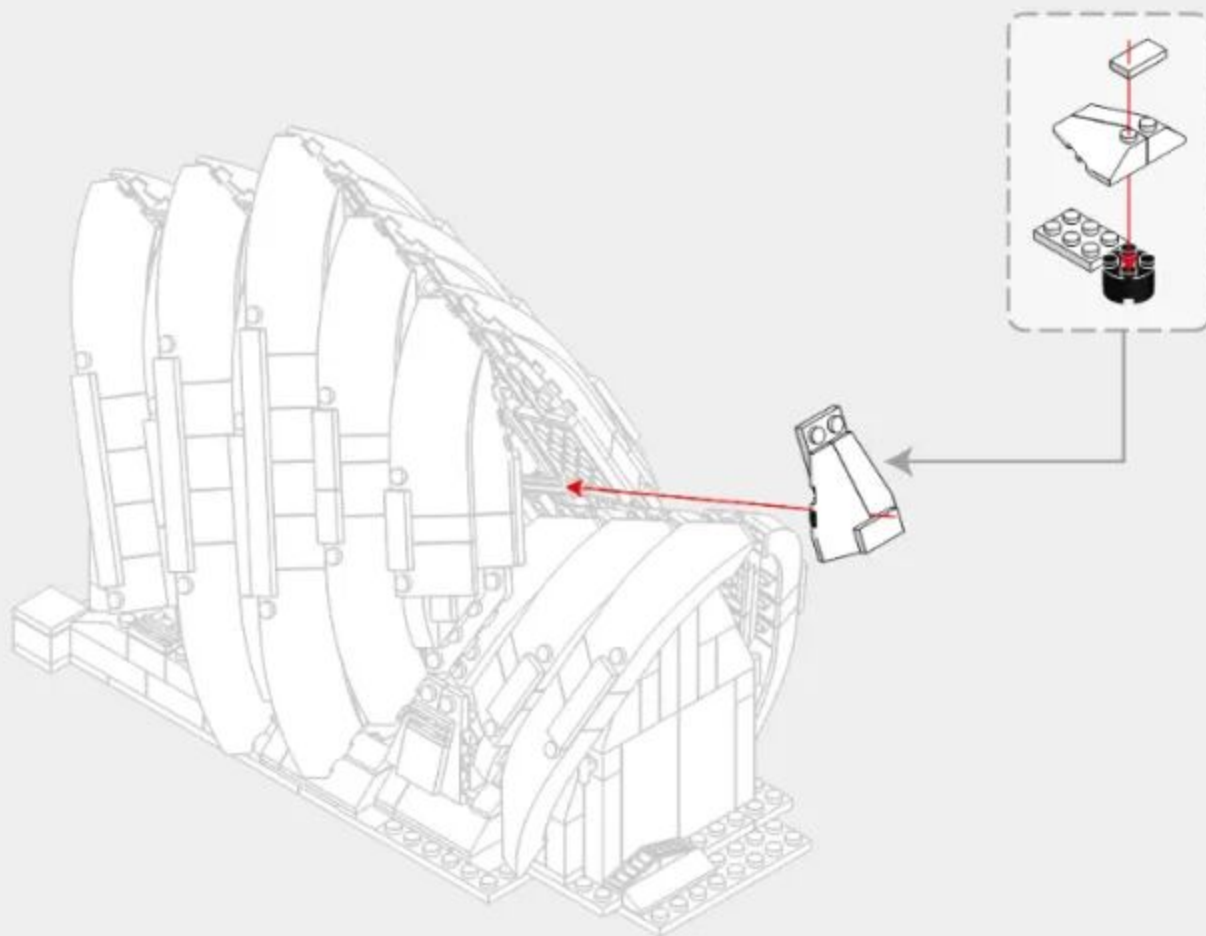
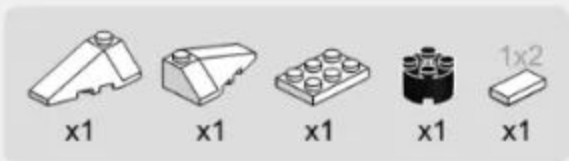

10-31

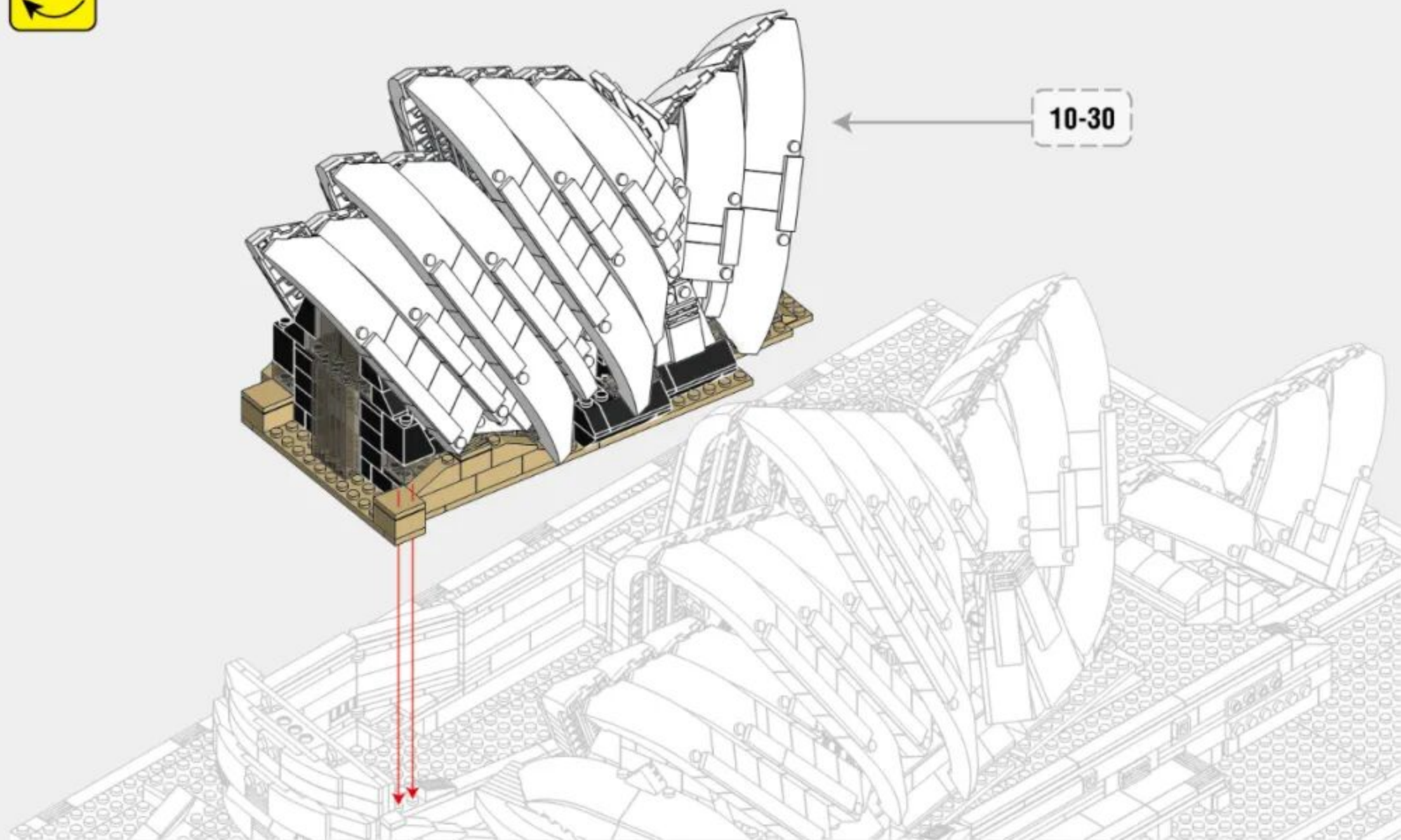

# 10-32

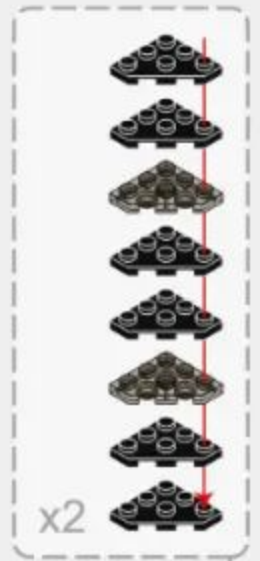
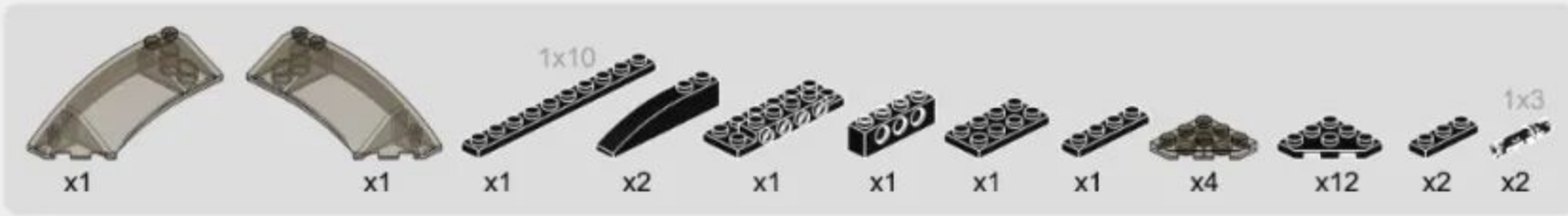

1



2



3



4

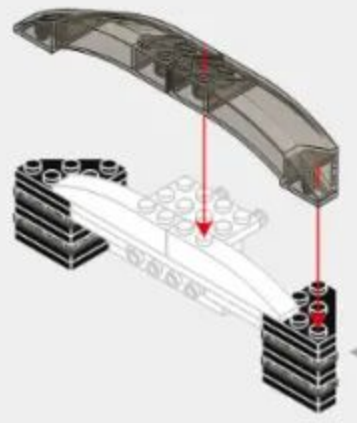

10-33

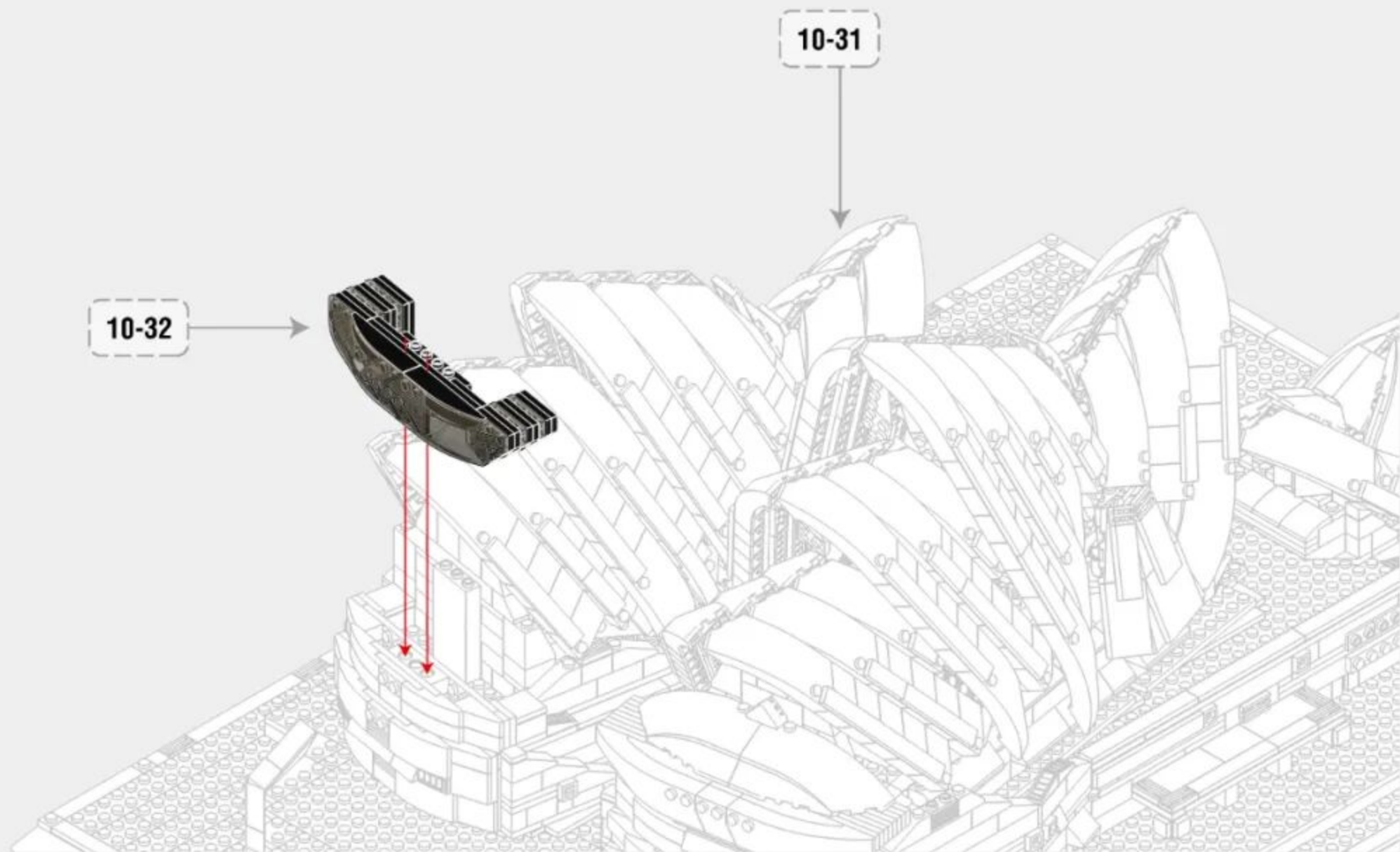

10-34

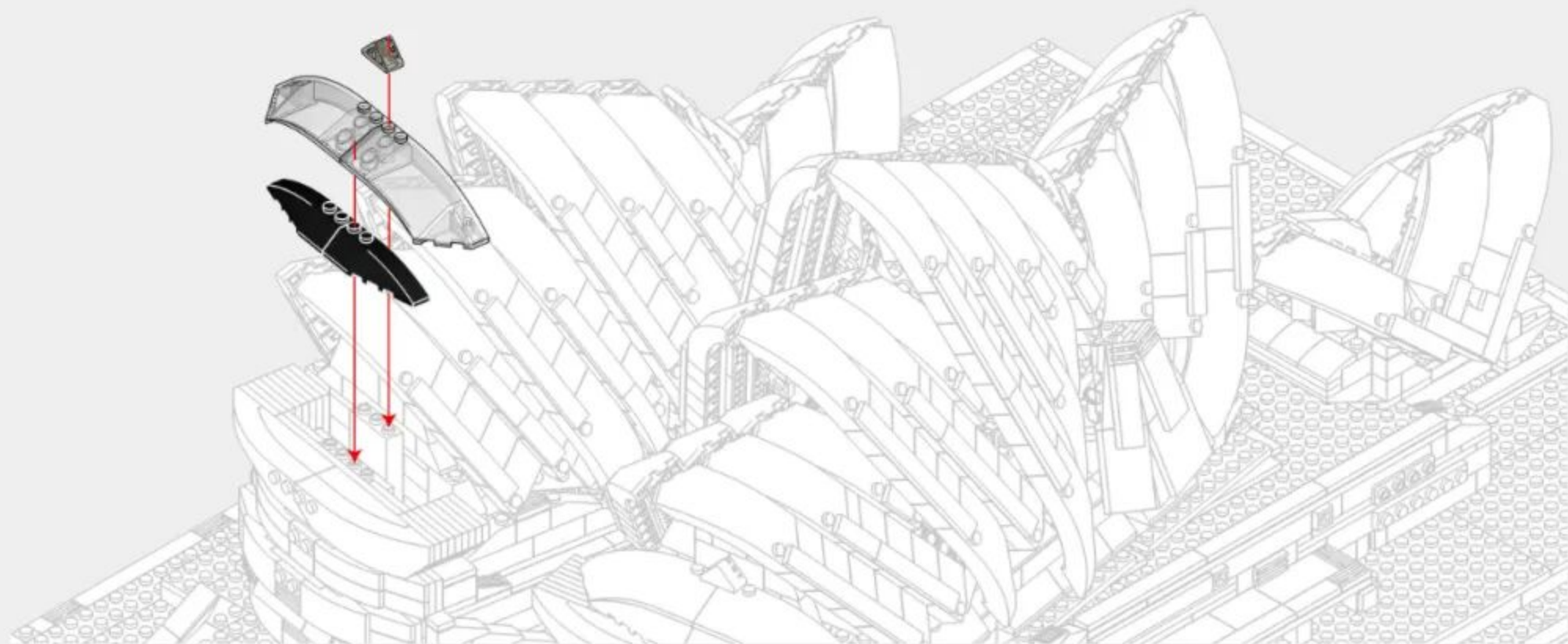

**11**  
**PACK**

**243**PCS

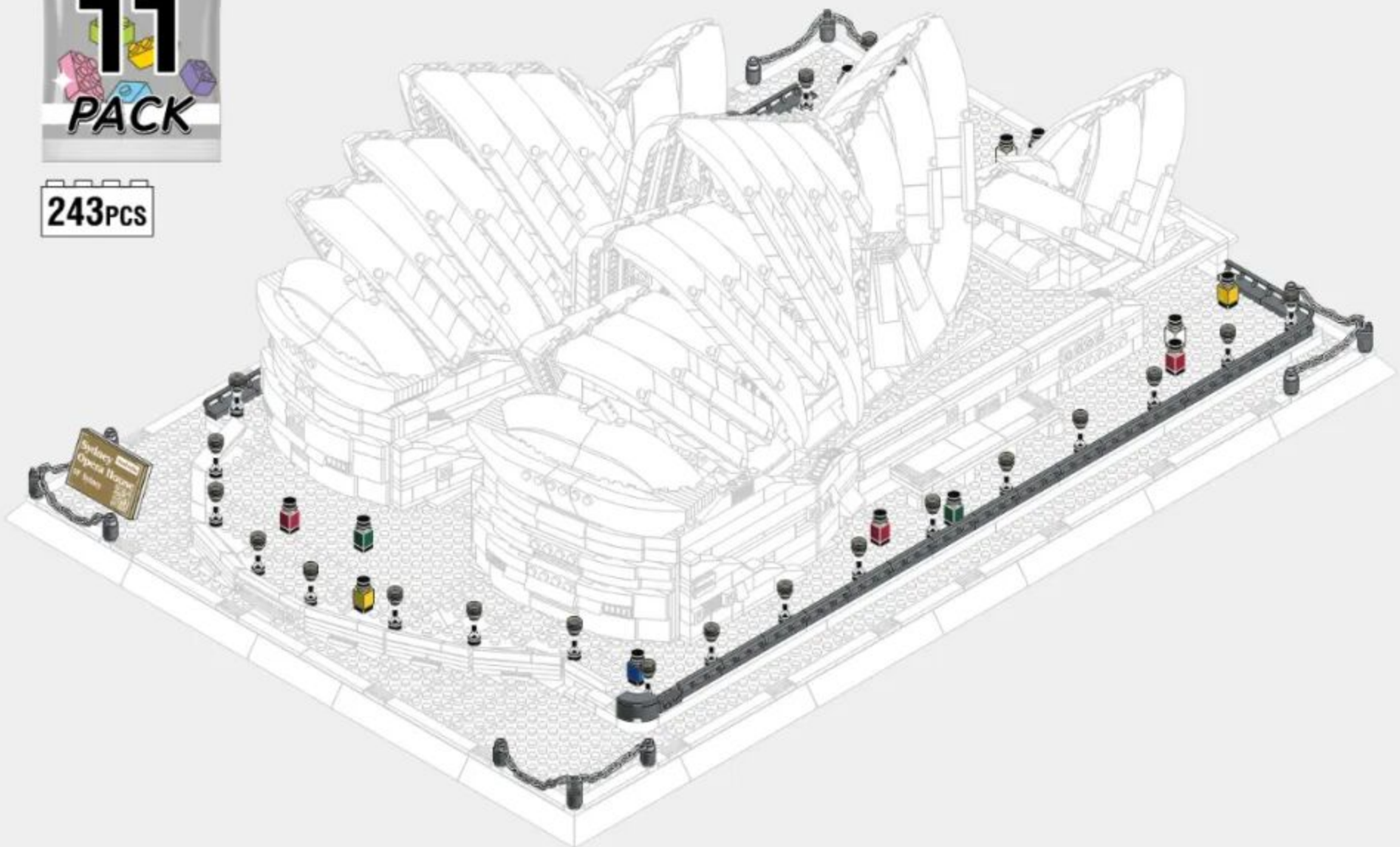

**228**

11-1

-  x1
-  x1
-  x1
-  x2
-  x5
-  x5
-  x5

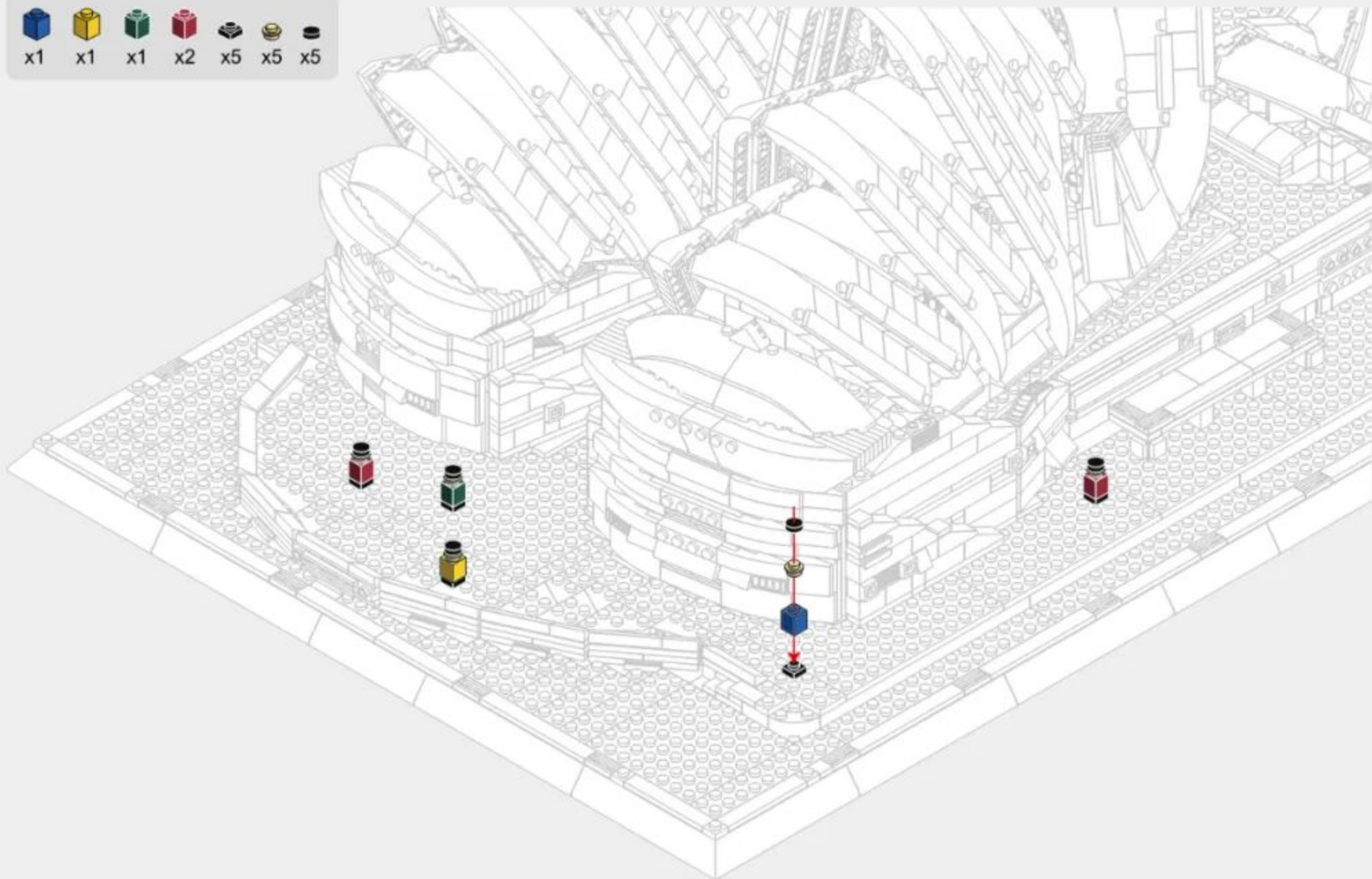

11-2

Icons for parts: a pin, a ball joint, a ball joint, and a ball joint.  
x11 x11 x11 x11



230

11-3

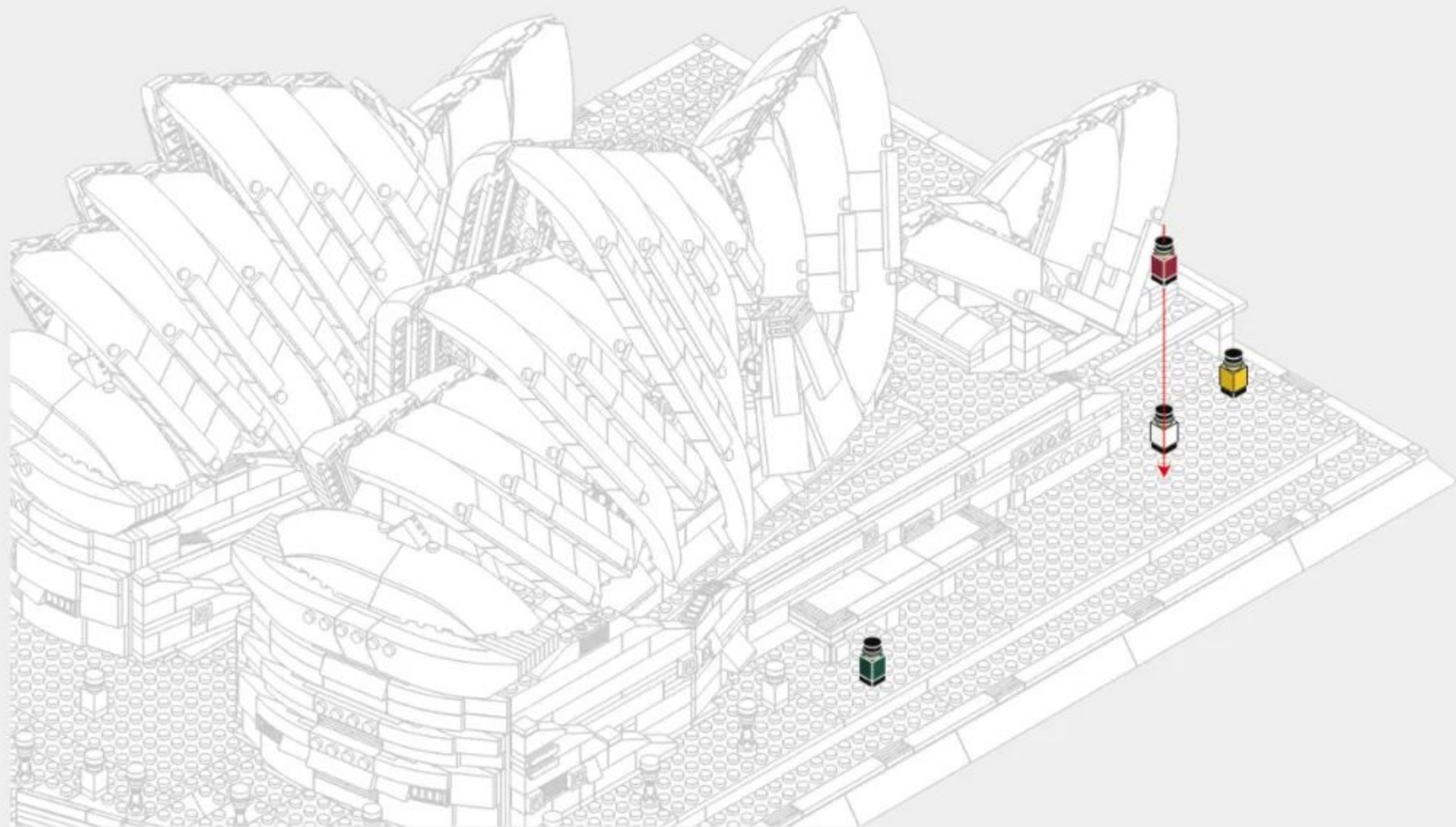

231

11-4

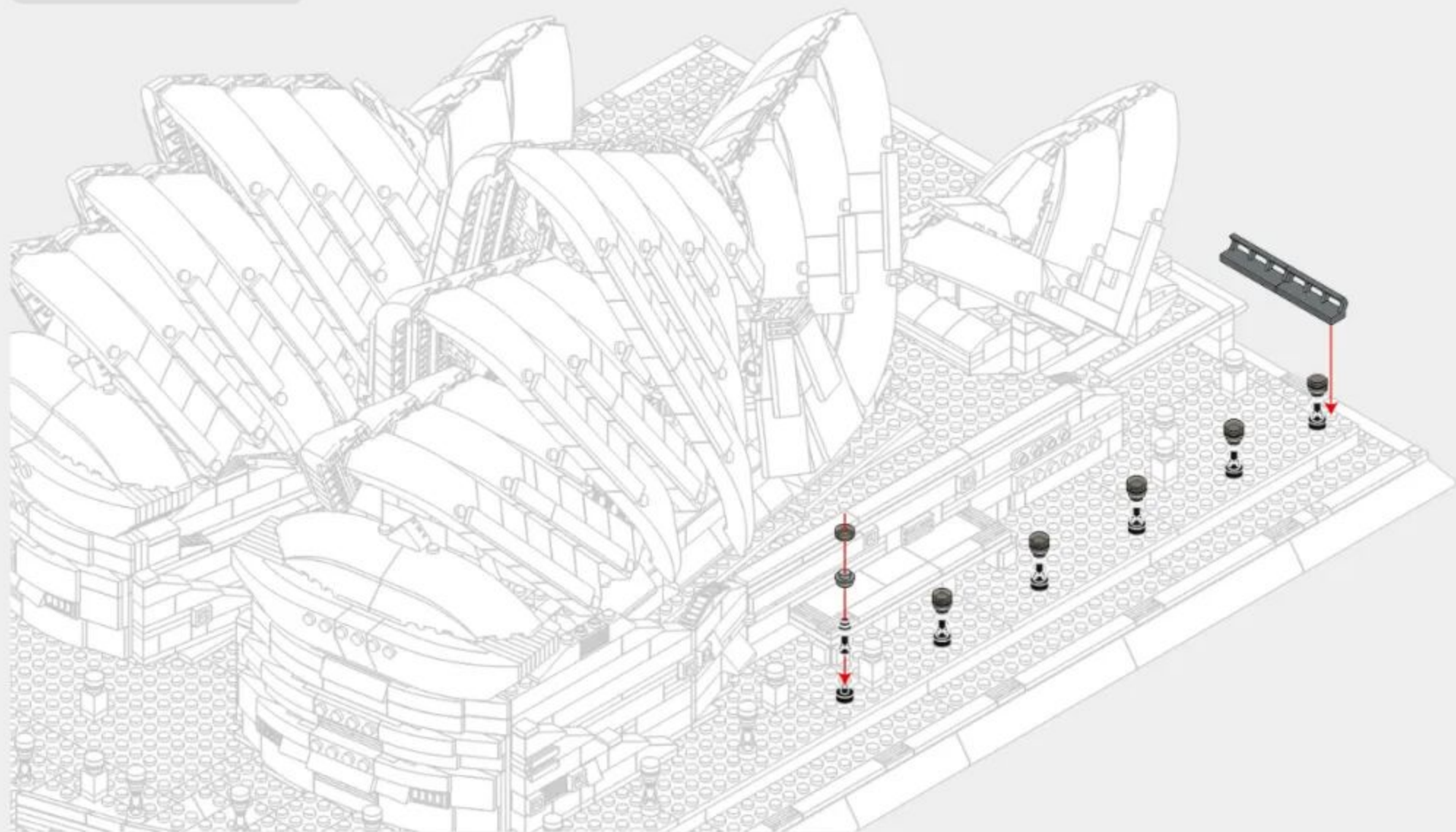

11-5

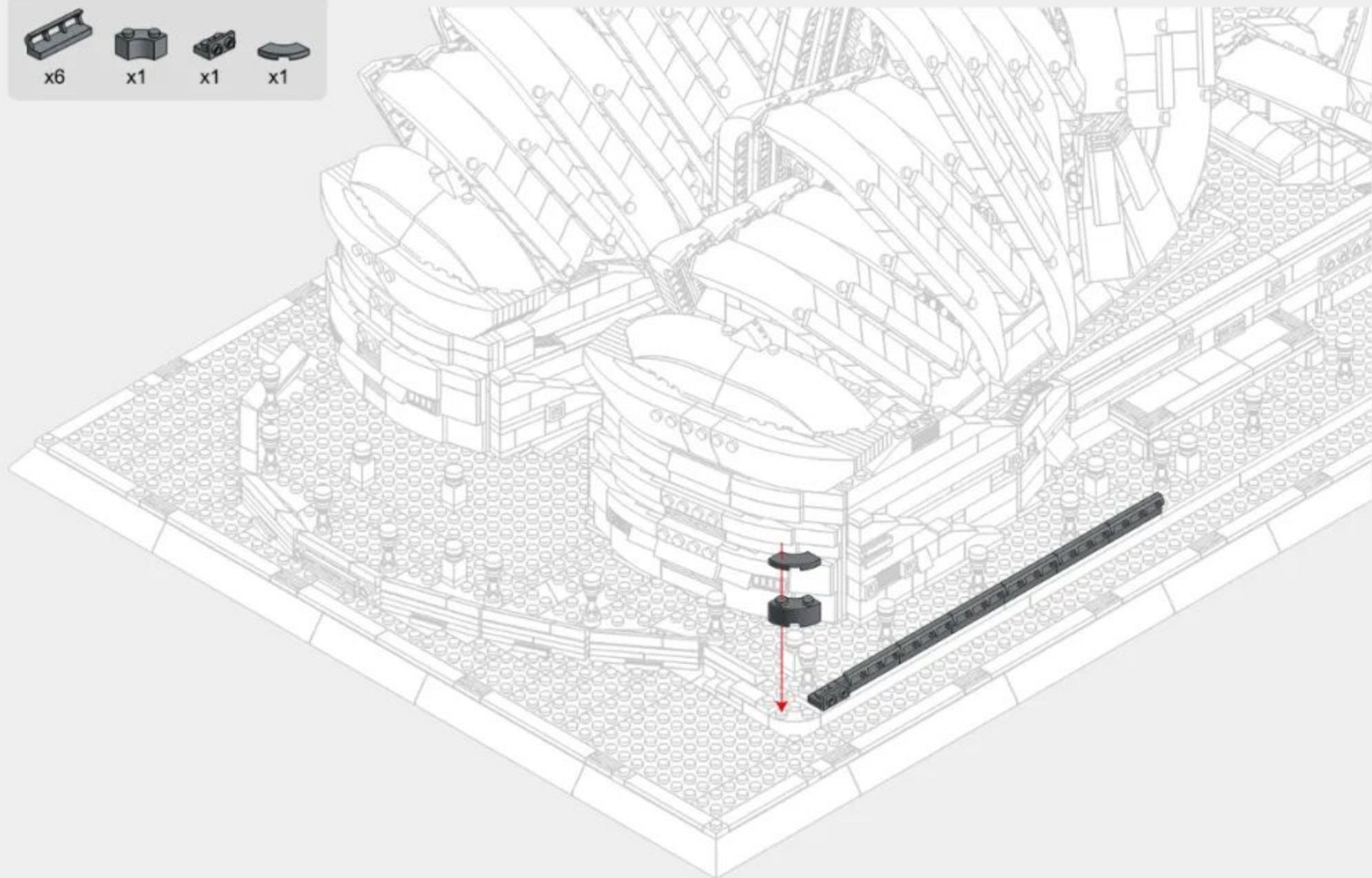

11-6

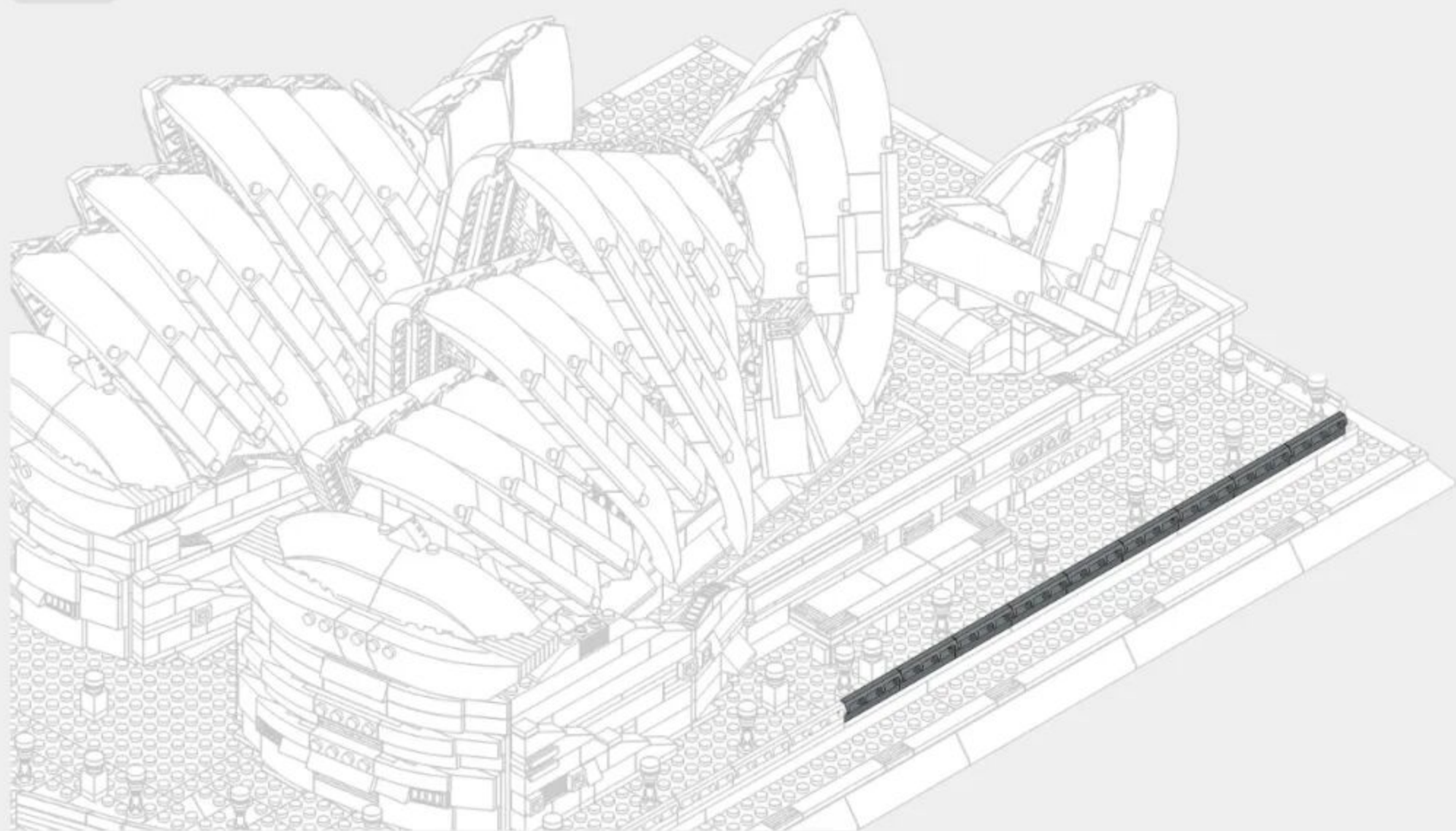

11-7

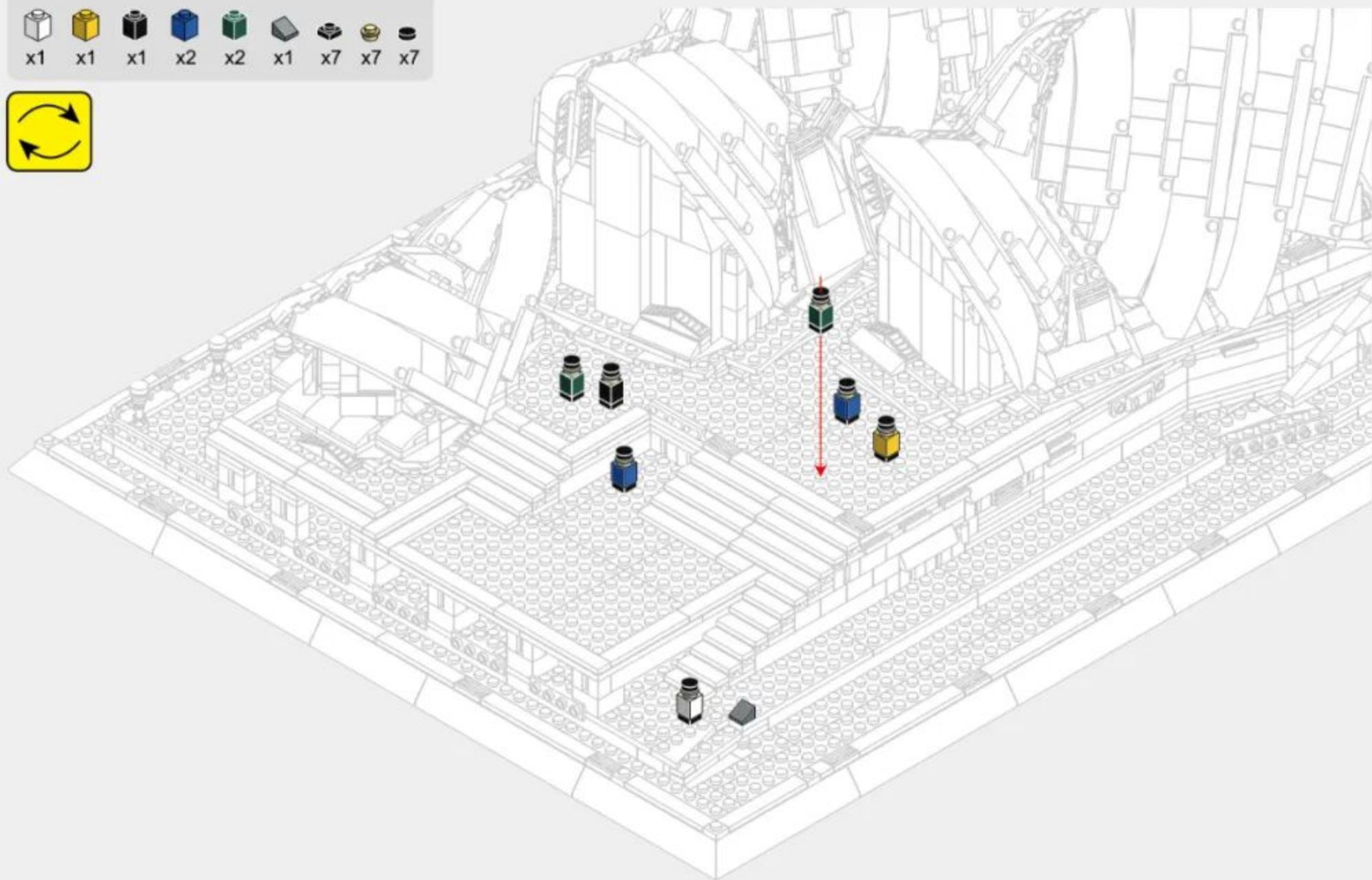

11-8

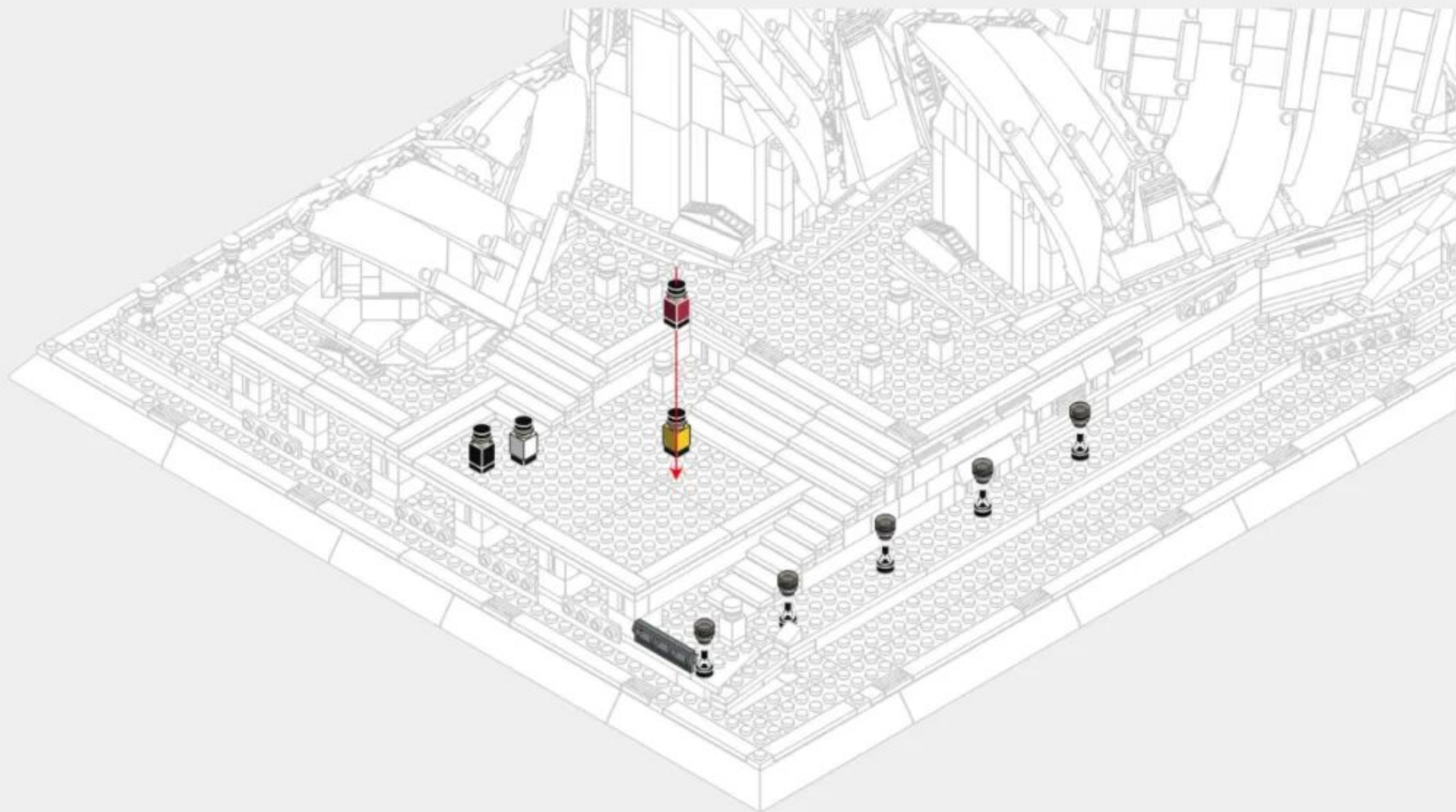

236

11-9

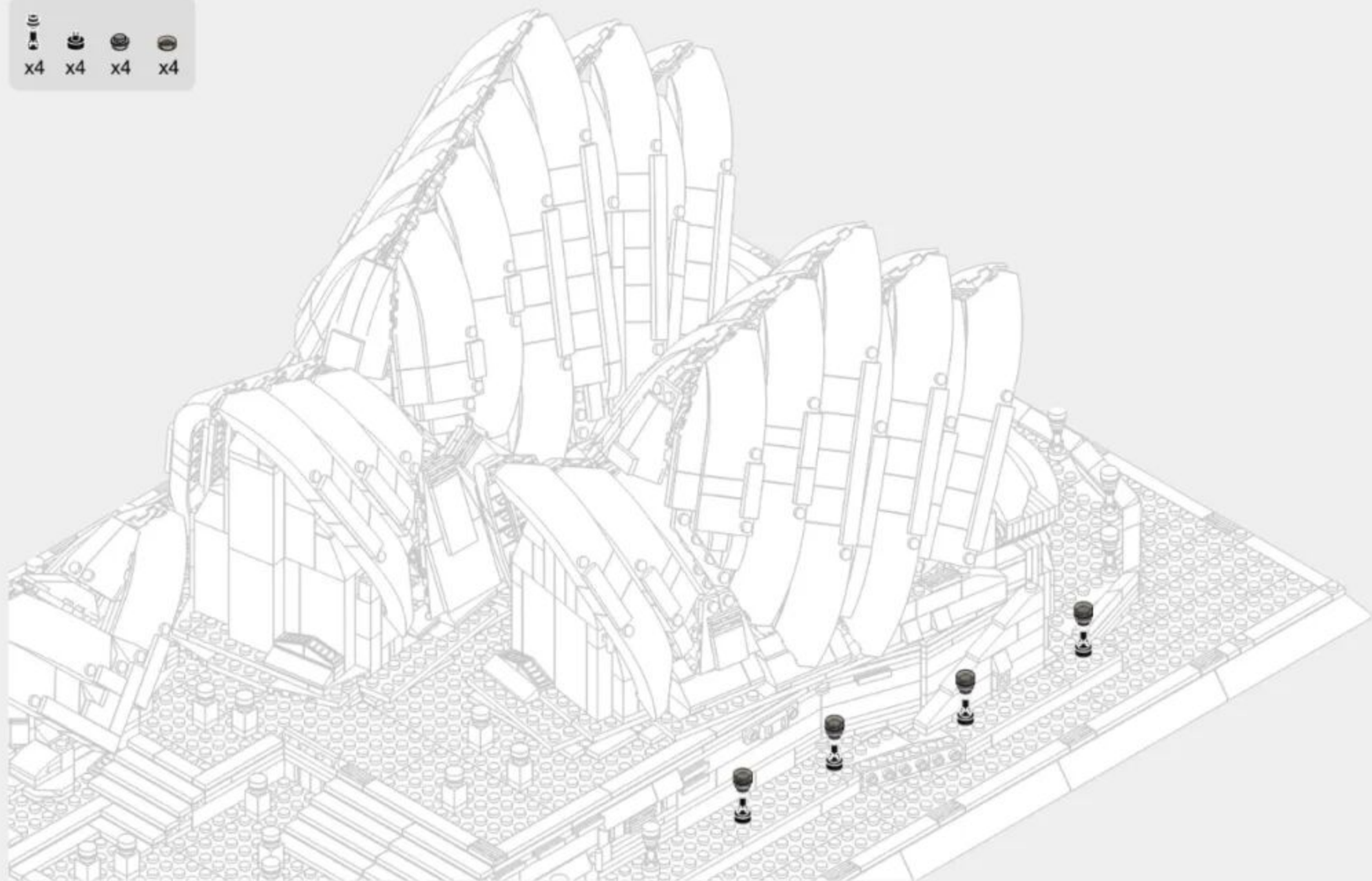

11-10

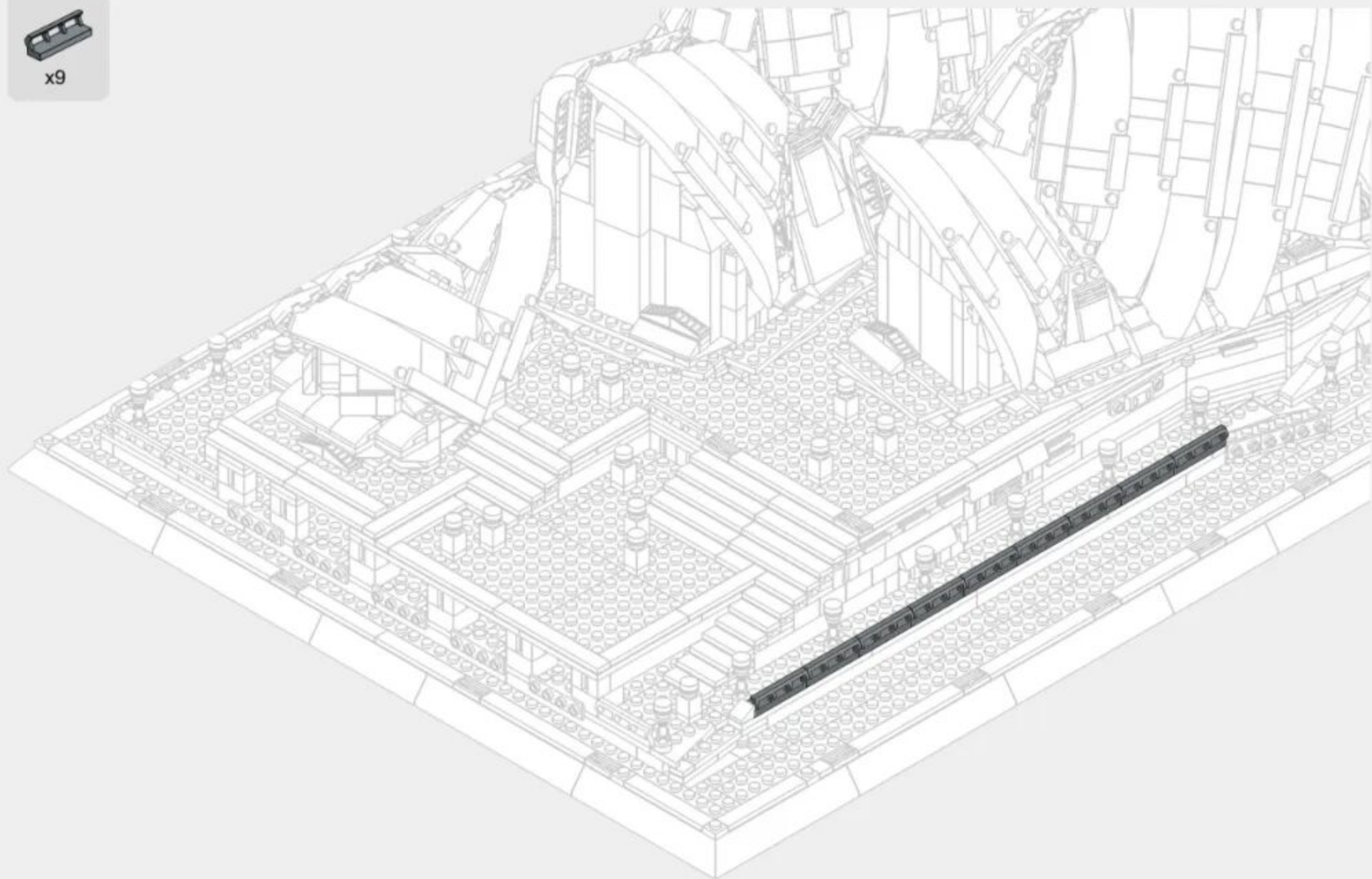

238

11-11

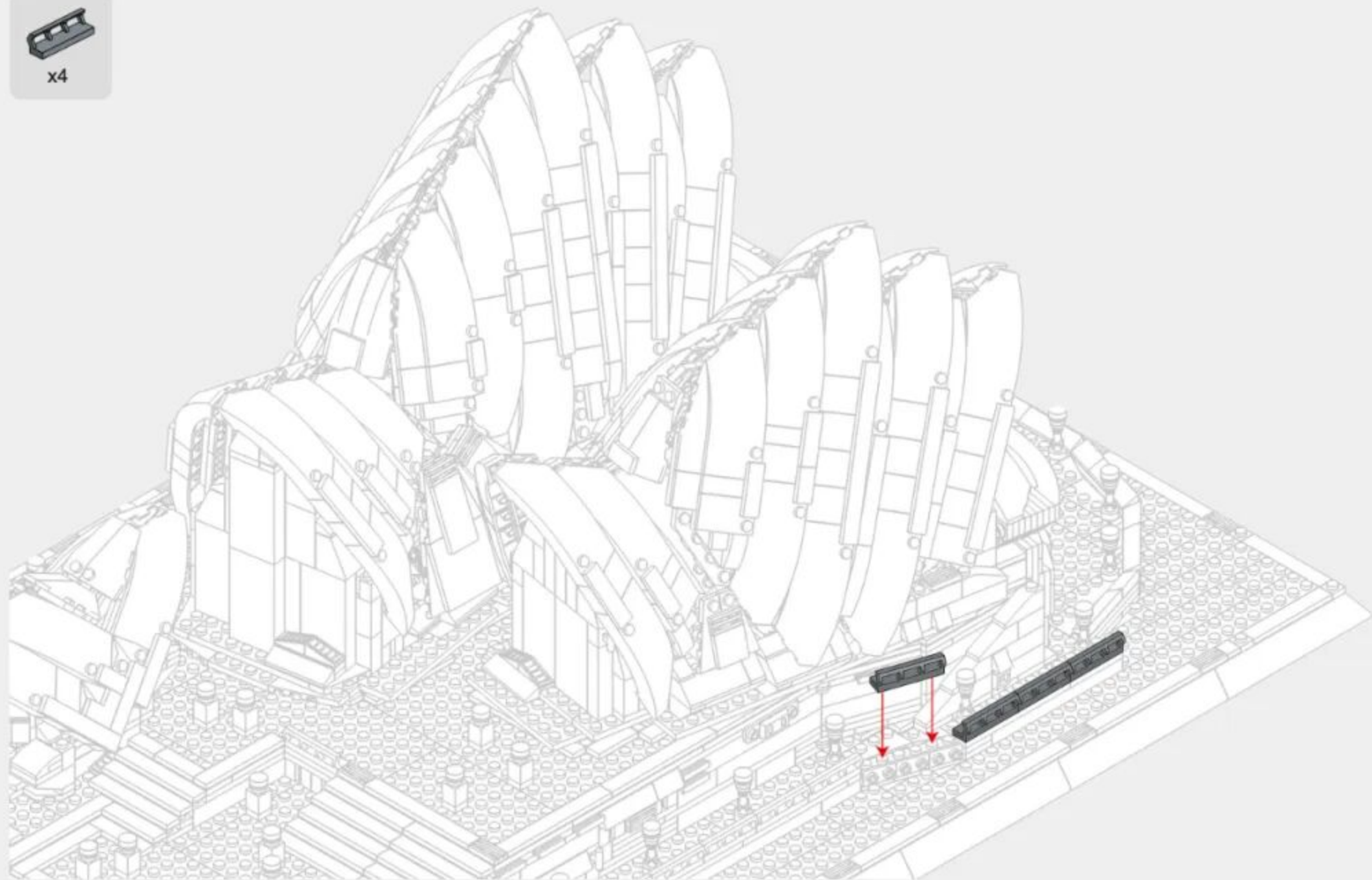

11-12

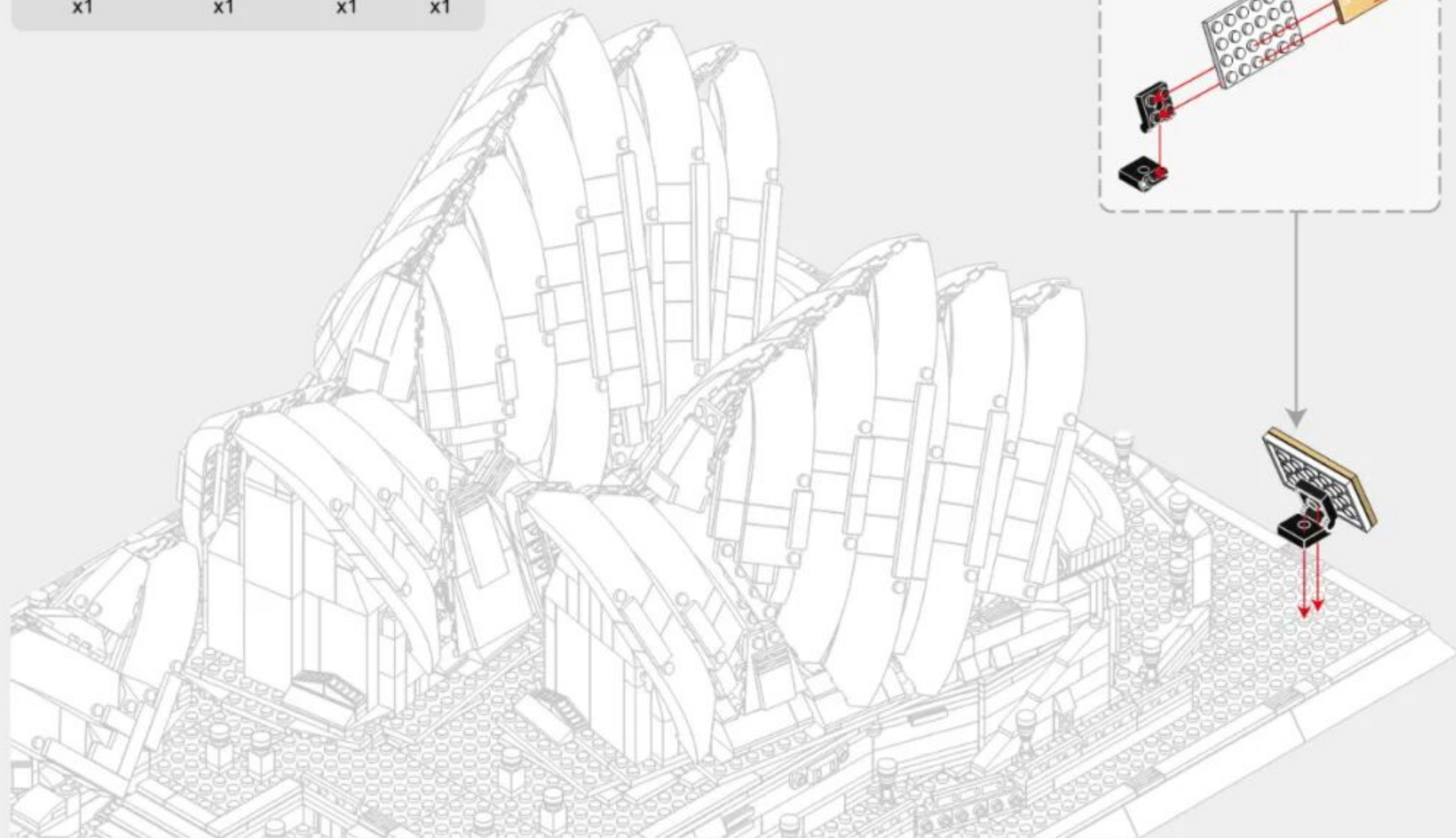
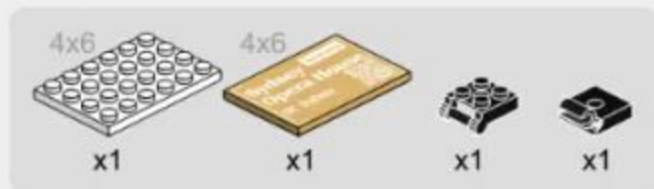

11-13

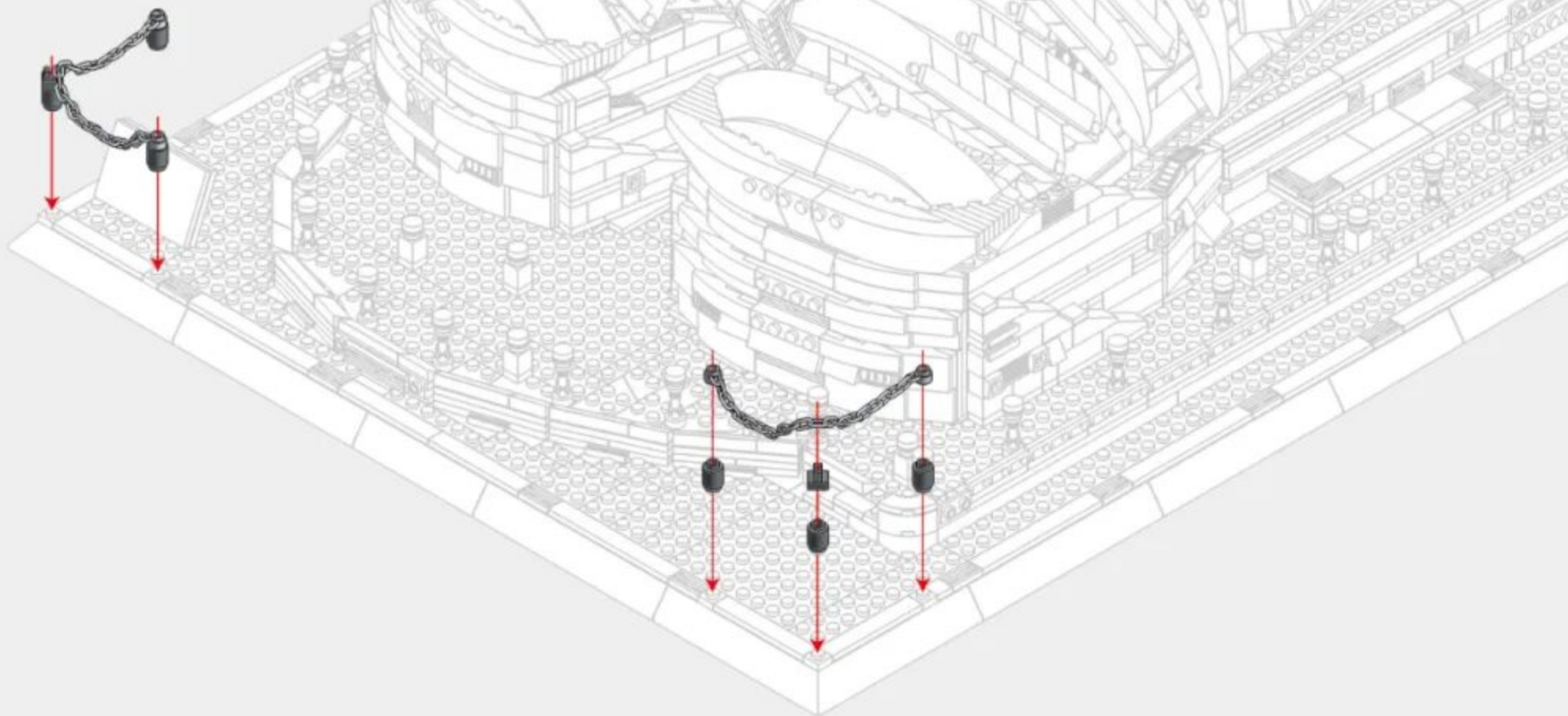

11-14

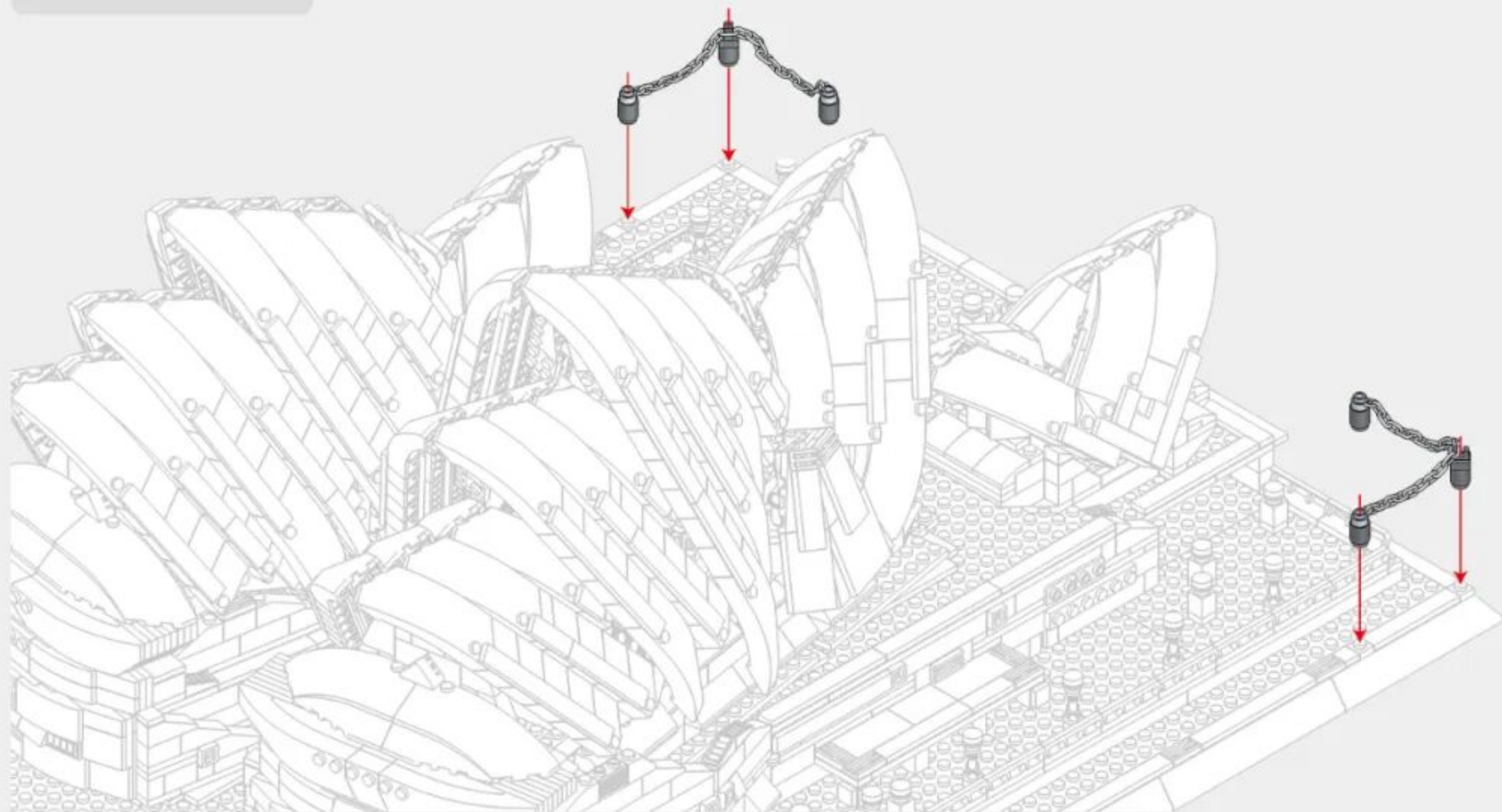



# ARCHITECTURE

The World's great architecture

Shaping Skills   Imagination & Curiosity   Mathematical   Self Discovery & Perception   Parent-Child Interaction   Problem Solving   Creativity



**6224 英国伦敦白金汉宫**  
BUCKINGHAM PALACE-LONDON,ENGLAND



**5225 意大利罗马斗兽场**  
COLOSSEUM-ROME,ITALY



**5226 日本东京帝国饭店**  
IMPERIAL HOTEL-TOKYO,JAPAN



**6211 德国柏林勃兰登堡门**  
BRANDENBURG GATE-BERLIN, GERMANY



**6222 中国甘肃长城-嘉峪关**  
JIAYU PASS-GANSU,CHINA



**6212 日本京都清水寺仁王门**  
NIOMON GATE OF KIYOMIZU-DERA-KYOTO,JAPAN



**6214 中国武汉黄鹤楼**  
YELLOW CRANE TOWER-WUHAN,CHINA



**6215 英国伦敦眼**  
LONDON EYE-LONDON,ENGLAND



**6221 中国北京故宫-太和殿**  
HALL OF SUPREME HARMONY-BEIJING,CHINA



**6213 俄罗斯莫斯科瓦西里大教堂**  
SAINT BASIL'S CATHEDRAL-MOSCOW,RUSSIA



**6220 沙特阿拉伯麦加大清真寺**  
GREAT MOSQUE OF MECCA,SAUDI ARABIA



**6219 美国纽约联合国大厦**  
UNITED NATIONS HEADQUARTERS-NEW YORK,AMERICA



**4214 美国华盛顿白宫**  
WHITE HOUSE-WASHINGTON D.C.,AMERICA



**4212 意大利罗马许愿池**  
TREVİ FOUNTAIN-ROME,ITALY



**4213 法国巴黎卢浮宫**  
MUSÉE DU LOUVRE-PARIS,FRANCE



**4218 新加坡-鱼尾狮**  
MERLION,SINGAPORE



**4210 埃及开罗吉萨金字塔**  
GREAT PYRAMID OF GIZA-CAIRO,EGYPT



**4219 英国伦敦双子塔桥**  
TOWER BRIDGE-LONDON,ENGLAND



**4216 美国华盛顿林肯纪念堂**  
LINCOLN MEMORIAL-WASHINGTON D.C.,AMERICA



**4217 新加坡-金沙酒店**  
MARINA BAY SANDS,SINGAPORE



**7210 中国上海世博会中国馆**  
CHINA PAVILION AT EXPO-SHANGHAI, CHINA



**4221 加拿大渥太华国会山庄**  
PARLIAMENT BUILDINGS-OTTAWA, CANADA



**4211 英国伦敦伊丽莎白塔**  
ELIZABETH TOWER-ENGLAND



**4220 美国纽约熨斗大厦**  
FLATIRON BUILDING-NEW YORK, AMERICA



**5227 美国纽约自由女神像**  
STATUE OF LIBERTY-NEW YORK, AMERICA



**4215 加拿大多伦多电视塔**  
THE CN TOWER-CANADA



**4222 阿联酋迪拜哈利法塔**  
THE BURJ KHALIFA TOWER-DUBAI, UAE



**5224 中国上海东方明珠广播电视塔**  
ORIENTAL PEARL TOWER-SHANGHAI, CHINA



**5212 美国纽约帝国大厦**  
EMPIRE STATE BUILDING-NEW YORK, AMERICA



**5213 马来西亚吉隆坡石油双塔**  
PETRONAS TWIN TOWERS-KUALA LUMPUR, MALAYSIA



**5214 意大利托斯卡纳比萨斜塔**  
LEANING TOWER OF PISA-TUSCANY, ITALY



**5216 英国伦敦伊丽莎白塔**  
ELIZABETH TOWER LONDON ENGLAND



**5219 俄罗斯莫斯科克里姆林宫钟楼**  
SPASSKAYA TOWER-MOSCOW, RUSSIA



**5220 阿联酋迪拜卓美亚帆船酒店**  
BURJ AL ARAB HOTEL-DUBAI, UAE



**5217 法国巴黎埃菲尔铁塔**  
EIFFEL TOWER-PARIS, FRANCE



**5221 中国台北101大楼**  
TAIPEI 101-TAIPEI, CHINA



**6223 中国武汉长江大桥**  
WUHAN YANGTZE RIVER BRIDGE



**5210 法国巴黎圣母院大教堂**  
CATHÉDRALE NOTRE DAME DE PARIS-PARIS, FRANCE



**5223 法国巴黎凯旋门**  
ARC DE TRIOMPHE-PARIS, FRANCE



**5211 印度阿格拉泰姬陵**  
TAJ MAHAL-AGRA, INDIA



5215 英国伦敦双子塔桥  
TOWER BRIDGE-LONDON,ENGLAND



5222 中国北京天坛祈年殿  
HALL OF PRAYER FOR GOOD HARVESTS-BEIJING,CHINA



6210 美国旧金山金门大桥  
GOLDEN GATE BRIDGE-SAN FRANCISCO,AMERICA



6216 中国北京万里长城（八达岭）  
THE GREAT WALL-BEIJING,CHINA



5218 中国北京天安门  
TIANANMEN TOWER-BEIJING,CHINA



6217 中国西藏布达拉宫  
POTALA PALACE-TIBET,CHINA



6218 芬兰罗瓦涅米圣诞老人办公室  
SANTA CLAUS OFFICE-ROVANIEMI,FINLAND



6225 墨西哥库库尔坎玛雅金字塔  
EL CASTILLO-KUKULKAN,MEXICO



6226 德国巴伐利亚新天鹅堡  
SCHLOSS NEUSCHWANSTEIN-BAYERN, DEUTSCHLAND



5228 美国芝加哥威利斯大厦  
WILLIS TOWER-CHICAGO, AMERICA



5229 土耳其伊斯坦布尔其少女塔  
MAIDEN TOWER-ISTANBUL,TURKEY



5230 中国湖南长沙爱晚亭  
AIWAN TING PAVILION-HUNAN,CHINA



5231 巴西里约热内卢救世基督像  
CRISTO REDENTOR-RIO DE JANEIRO, BRASIL



5232 美国宾夕法尼亚州流水别墅  
FALLINGWATER-PENNSYLVANIA, AMERICA



5233 美国芝加哥范斯沃斯住宅  
FARNSWORTH HOUSE-CHICAGO, AMERICA



5234 美国华盛顿唐人街  
CHINA TOWN-WASHINGTON, D.C., AMERICA



3210 美国纽约自由女神像  
STATUE OF LIBERTY-NEW YORK,AMERICA



4223 中国北京清华园  
TSINGHUA CAMPUS-CHINA,BEIJING



7211 中国湖南岳阳楼  
YUEYANG TOWER-CHINA,HUNAN



8210 澳大利亚悉尼歌剧院  
SYDNEY OPERA HOUSE-AUSTRALIA,BENNELONG POINT

# SYDNEY OPERA HOUSE

COUNTRY: Australia

CITY: Sydney



微信扫一扫  
补件更简单



Ver. 8210220308