

XINGBAO®  
星堡积木

长乐坊



长安朱雀街

盛世唐朝

星堡中华街系列

NO.01030

# 盛世唐朝

唐代是中国封建社会经济文化发展的成熟时期，其建筑技术和艺术也有巨大发展。唐代建筑在继承两汉以来成就的基础上，吸收、融合了外来的建筑文化元素，形成一个完整的建筑体系。这个体系由都市建筑、宫殿建筑、佛教建筑等方面组成。就唐代宫殿建筑而言，大明宫、兴庆宫和华清宫最具代表性，有着鲜明且彼此不同的文化特征。而在全国，则出现了许多著名地方城、商业和手工业城，如广陵、泉州、洪州、广州等。

唐朝建筑的风格特点规模宏大，气势磅礴，庄重大方，整齐而不呆板，华美而不纤巧，舒展而不张扬，古朴却富有活力，斗拱硕大并将木质建筑中的斗拱技艺发展到顶峰。现存

木质建筑物反映了唐代建筑艺术加工和结构的统一，斗拱的结构、柱子的形象、梁的加工等都令人感到构件本身受力状态与形象之间内在的联系，达到了力与美的统一。而色调简洁明快，屋顶舒展平远，门窗朴实无华，给人庄重、大方的印象，这是在宋、元、明、清建筑上不易找到的特色。建筑材料方面除了木、土、石、竹、砖、瓦外，琉璃烧制技术的提高也增加了它的使用率，统治阶级营造的华美宅第和园林艺术意境十分高超。此外，唐代的汉族砖石建筑也得到了进一步发展，佛塔大多采用砖石建造。包括西安大雁塔、小雁塔和大理千寻塔在内的中国现存唐塔均为砖石塔。

## GREAT TANG DYNASTY

Tang dynasty was the prosperous and mature period of Chinese feudal society. At that time its economy, culture, architecture technology and art developed very well. With the basis of architectural achievements of Han dynasties, the architecture in Tang dynasty developed into a whole architectural system via integrating and absorbing foreign architectural culture elements.

This system included metropolitan architecture, palaces and Buddhist architecture.

In terms of palaces, Daming Palace Xingqing Palace and Huaqing Palace were most symbolic. They each had distinct and different cultural characteristics. While at that time in China a number of famous business cities and handicraft industry cities sprung up. For instance, Guangling, Quanzhou, Hongzhou and Guangzhou.

The architecture characteristics in Tang dynasty were as follows:

They had grand scale and magnificent styles with solemn and clean appearance.

They were gorgeous instead of being stiff and empty.

They which offered people comfortable and energetic feelings had antique beauty.

Their large bucket arches enabled the bucket arch technology in wooden architecture to reach its peak. The current wooden architecture represents the unity of art embellishment and structure of architecture in Tang dynasty. The structure of bucket arches, the image of pillar and embellishment of beam enabled people to feel the inner relations between strained condition and image of components, which was the unity of beauty and power. Their colors were concise and lively while their roofs were stretching far. Windows and doors were simple, with which people could feel their beauty and refulgence. All these characteristics seldom appeared in Song dynasty, Yuan dynasty and Qing dynasty. For the aspect of building materials, woods, soil, stone, bamboo, brisk and tile had been used.

Apart from those, with the development of firing technology colored glaze had been used more often. The ruling class had proficiency in building luxurious houses and beautiful gardens and conveying aesthetic feelings. In addition, the Han nationality masonry architecture had developed. Pagodas were mainly constructed by using masonry. Big Wild Goose Pagoda in Xi'an, the Small Goose Pagoda and Dali Qianxun Pagoda were constructed by using masonry. All of them were built in Tang dynasty.





盛世唐朝

# 长乐坊

酒肆·马吊馆·赌坊



唐朝时代，赌博几乎成为当时的时尚，当时多数皇帝都喜欢赌博，其中以武则天和玄宗等最甚。唐玄宗与杨贵妃常以赌博取乐，曾留下历史上有名的“骗子乱局”的故事；武则天曾经主办过赌局，令文武百官都加入进来。受朝廷的影响，唐代的官吏和民间也十分好赌，这几乎成了一时风尚，其中“叶子戏”与“斗鸡”尤为兴盛。

唐朝赌坊流行的叶子戏，是骨牌戏的一种。唐玄宗跟杨贵妃便常玩“叶子戏”，《成定录》载“咸通以来，天下尚之”。至明朝时成为“马吊”，最终演化为“麻将牌”。

到了唐明皇时期，大唐已经进入了鼎盛，许多人有钱又有闲，艰苦奋斗让位于奢靡的生活，从中央到地方都开始玩起“斗戏”，而“斗鸡”则成为当时最重要的博戏之一。不仅李隆基爱玩斗鸡，整个长安城中斗鸡者不计其数。甚至有专门靠养斗鸡维持生活的人，得到皇帝的垂青，专门招来，替皇帝养鸡。

In Tang dynasty, gambling became very popular. At that time many emperors were fond of gambling. For example, Empress Wu Zetian and Emperor Xuanzong regarded it as a hobby. Emperor Xuanzong had fun in gambling with his concubine Yang Yuhuan and they left a famous story called "fraud created a messy situation". Empress Wu Zetian had held a gambling party and asked hundreds of civil and military officials to take part in. Because of the effect of imperial court, folks and officials also liked gambling very much. Gambling was regarded as a fashion and playing cards and cockfighting gained great popularity.

Playing cards which was popular in casinos of Tang dynasty was a kind of dominoes. Emperor Xuanzong always had fun in playing cards with his concubine Yang Yuhuan. According to Xianding Records, from the year of Xiantong, playing cards was a very popular entertainment activity. And its name was Madio in Ming dynasty and at last changed into mahjong.

When it came to the period of Emperor Xuanzong's reign, Tang dynasty welcomed its flourishing age. Many people were rich and had a lot of time for leisure. They prefer luxurious lives to hard work and plain living. From imperial court to local cities, people had fun in playing fighting games.

Among them cockfighting was the most significant one. Emperor Xuanzong liked to play cockfighting and in Chang'an city a large number of people also liked this game very much. Even some who made a living by keeping fighting cocks can be called in by the Emperor. And they later kept fighting cocks for him.

# 长乐坊

酒肆·马吊·赌坊

长乐坊

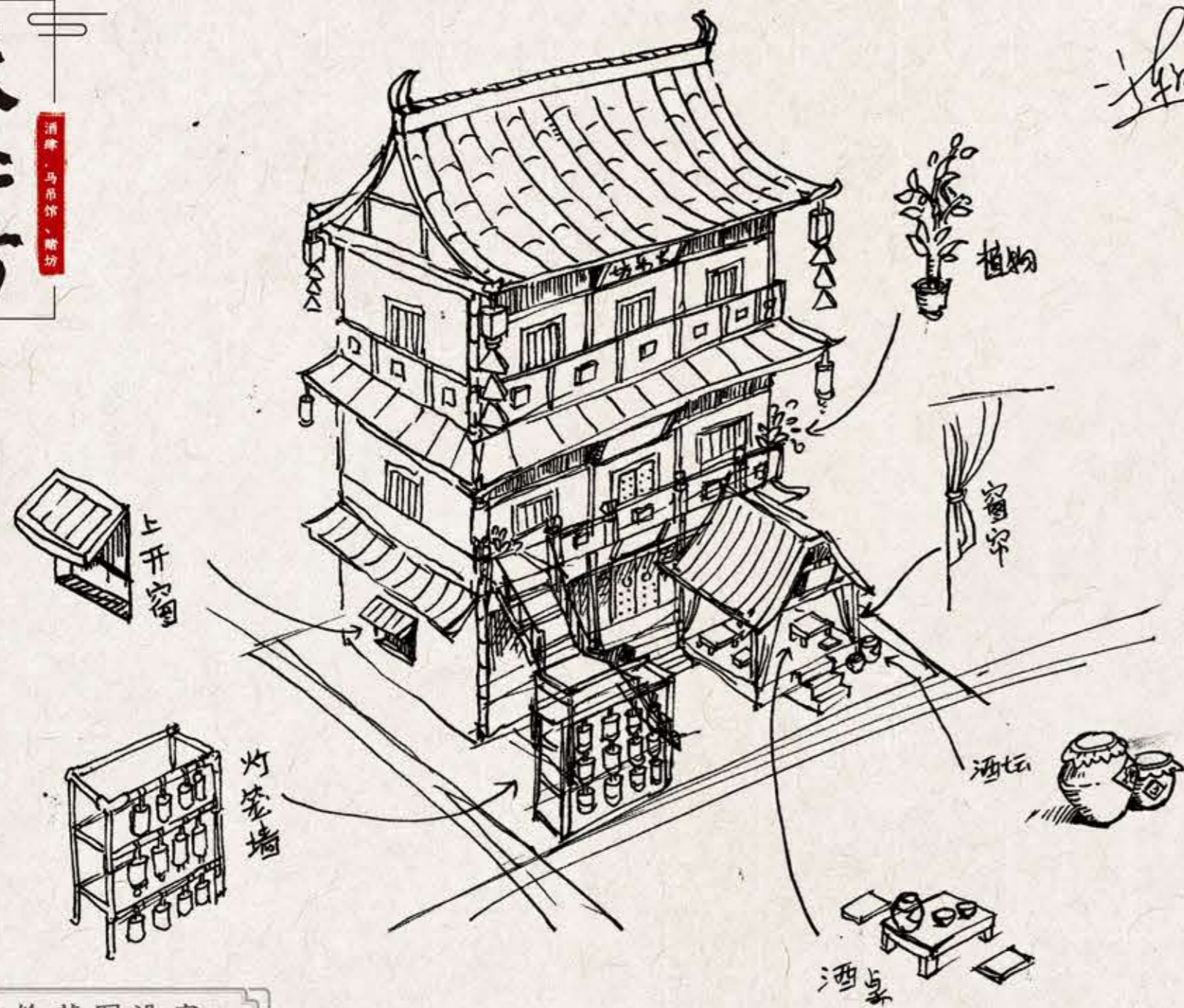

三楼贵宾室，一桌麻将，二楼有梯上去!

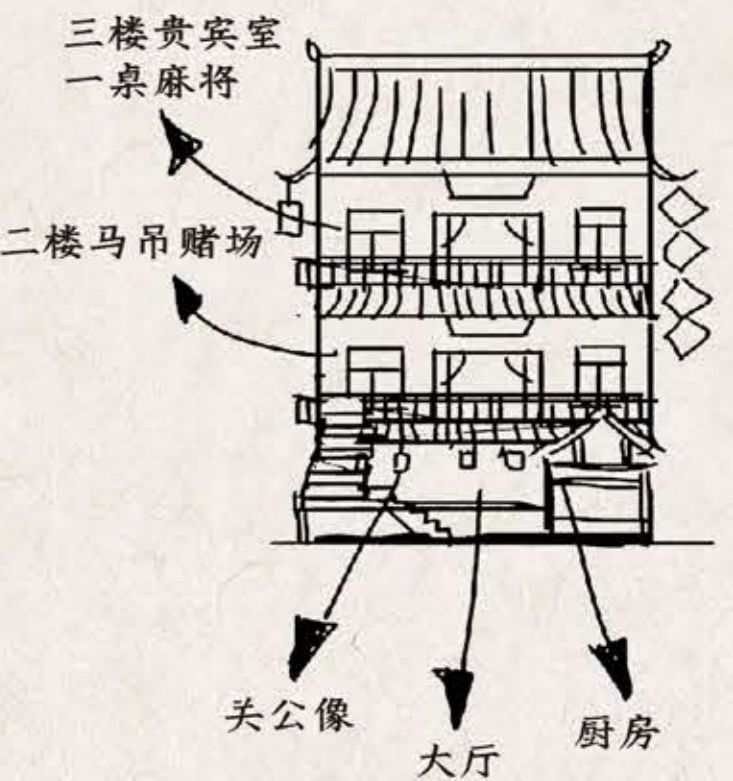
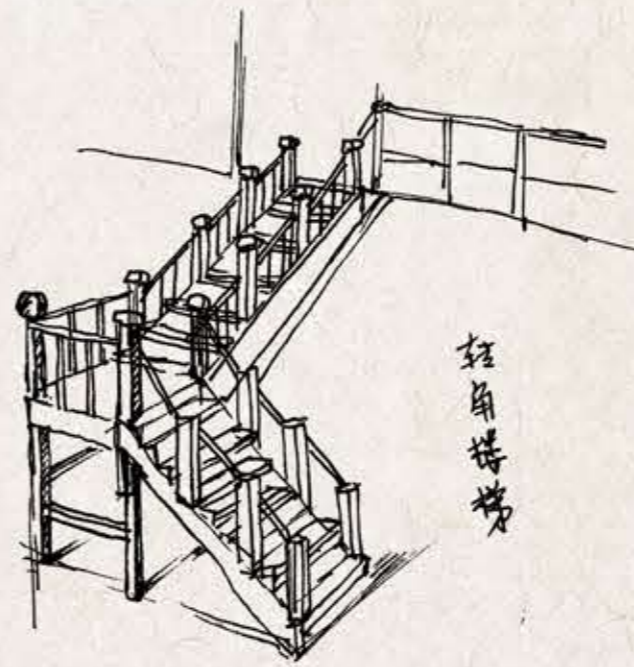
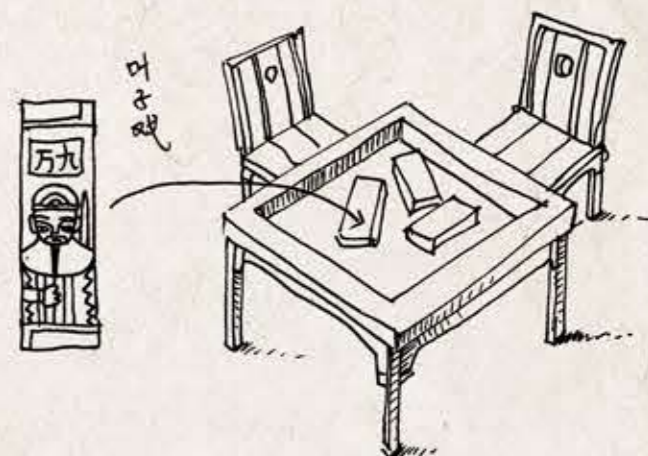

盛世唐朝

# 长乐坊

酒肆·马市·赌坊



屋脊，屋顶相对的斜坡或相对的两边之间顶端的交汇线。

The ridges were the opposite slopes in roofs or intersection lines of the top of opposite sides.

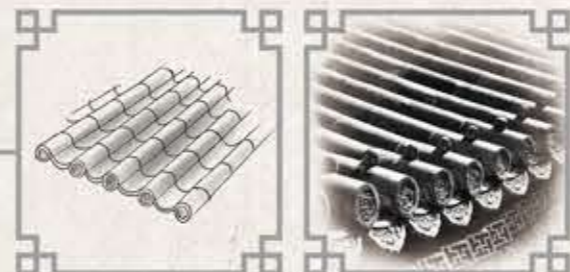

坡屋面系统的历史可以追溯到远古，房屋建筑几乎都是坡屋面的。

Pitched roof had its origins in remote antiquity and most of the buildings had pitched roofs.



窗花已有上千年的历史，在宋朝、元朝逐渐流传，逐渐成形。

With a history of more than one thousand years, paper-cut for window decoration was inherited and enhanced from Song dynasty and Yuan dynasty.

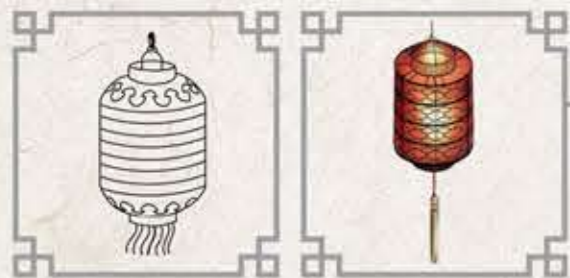

灯笼，又称灯彩，起源于2000多年前的西汉时期。

Lanterns which was called coloured-lantern had its origins in the period of the Western Han Dynasty 2000 years ago.

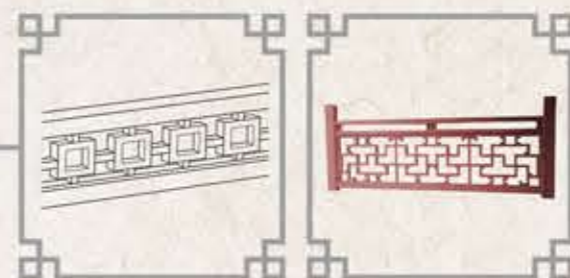

栏杆中国古称阑干，也称勾栏，是桥梁和建筑上的安全设施。

Handrail was called Langan or Goulan in ancient China, which was safety facilities in bridge and buildings.



桌子：上有平面，下有支柱，面上用以放东西或供做事情用的器物，一般用为家具。

Table: the upper part is a flat surface and the bottom part are table legs. People can put things on a table or use it in work, which is regarded as a kind of furniture.

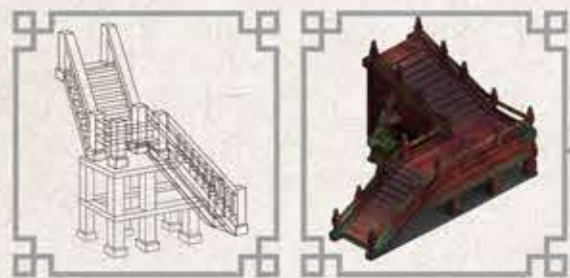

古楼梯的建造采用的是一种独特古工艺技术，叫卯榫。卯榫是中国木质古建筑常用的结构。

In ancient times people used mortise and tenon which was a special and historical craft technology to build stairs. Mortise and tenon was in common use in ancient wooden architecture in China.



椅子：椅、凳的起源，必须从汉魏时经印度传入的胡床谈起。

Chairs or stools originated from Han and Wei Dynasties. Their origins must be related to the benches introduced from India in Han and Wei Dynasties.

## 初始场景设定

SETTING INITIAL SCENE

初始设定  
INITIAL SETTING



优化设定  
OPTIMAL SETTING



美化设定  
BEAUTY SETTING



最终设定  
FINAL SETTING



盛世唐朝

# 长乐坊

酒肆·马市·赌坊

## 建筑组合设定

architecture combination setting

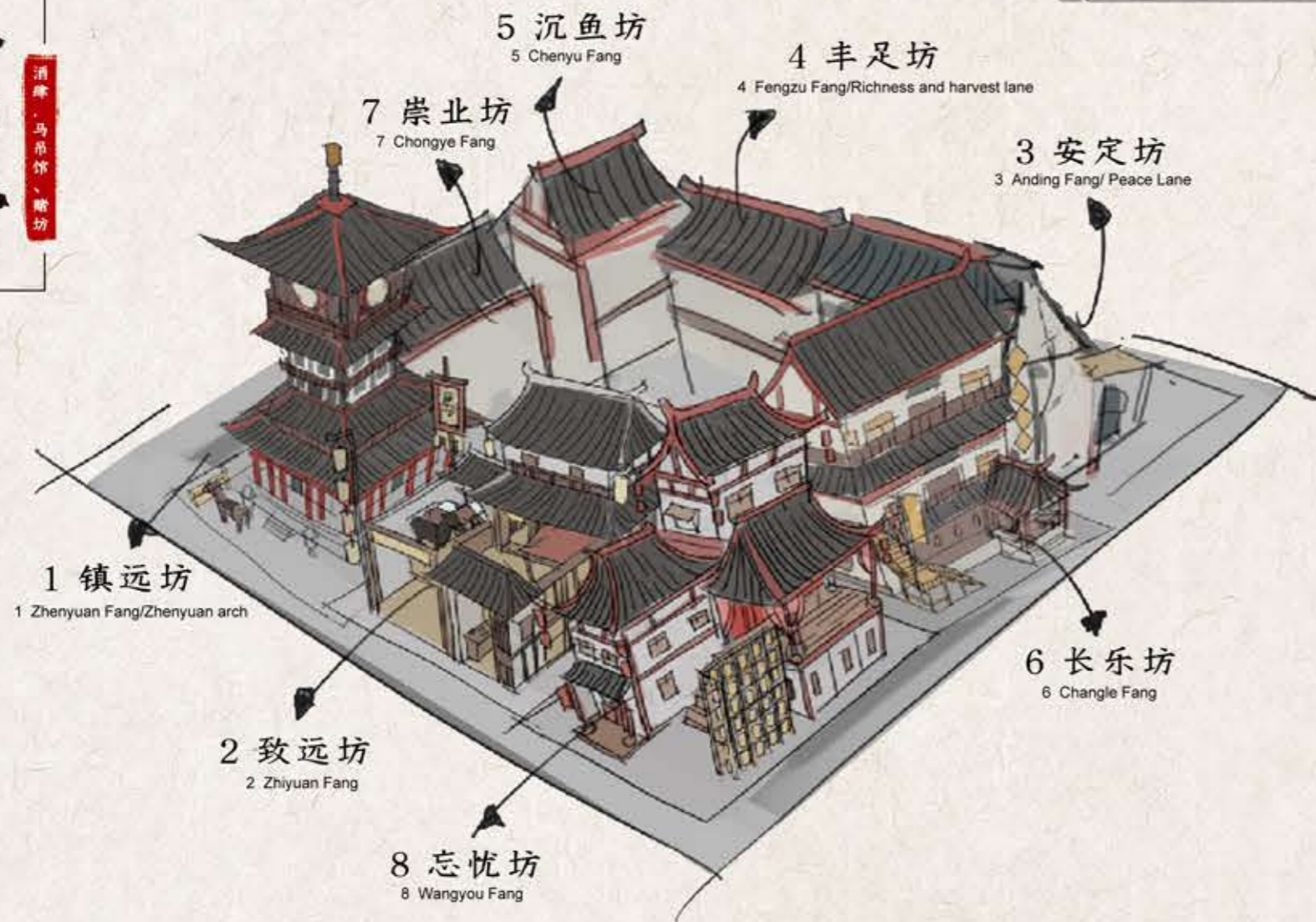

唐朝的长安、成都、扬州、洛阳等城市人口众多，非常繁华，长安人口更是超过百万，城市道路建设也很具代表性。长安的道路网是棋盘式，南北向14条街，东西向11条街，位于中轴线的朱雀大街宽达150米，街中80米宽，路面用砖铺成，道路两侧有排水沟和行道树，布置井然，气度宏伟。

There were several populous and prosperous cities in Tang dynasty such as Chang'an, Chengdu, Yangzhou and Luoyang. All these cities were big cities. The population of Chang'an was more than one million. The road construction in Chang'an was typical and orderly, which was like a chessboard. There were 14 north-south streets and 11 east-west streets. Zhuque Avenue located in axis was 150 meters in width and inside the avenue its width was 80 meters. The avenue was paved with bricks. On both sides there were drains and trees. The structure and construction were orderly and grand.

## 最终场景设定

final scene setting



盛世唐朝

# 人物设定

唐朝人物

## 对襟襦裙

A kind of Chinese-style jacket with buttons down the front and dress



设计草图  
Design sketch



成品效果  
Effect

## 齐胸襦裙

Jacket standing chest high and dress



设计草图  
Design sketch



成品效果  
Effect

## 圆领袍

Gown with a round collar



设计草图  
Design sketch



成品效果  
Effect

## 齐胸襦裙

Jacket standing chest high and dress



设计草图  
Design sketch



成品效果  
Effect

盛世唐朝

# 人物设定

唐朝人物

## 交领襦裙

Jacket with stitched collars and dress



设计草图  
Design sketch



成品效果  
Effect

FIGURE SETTING

## 齐胸襦裙

Jacket standing chest high and dress



设计草图  
Design sketch



成品效果  
Effect

FIGURE SETTING



星堡积木



笛墨文化

星堡积木 & 笛墨文化

联合制作

Co-develop by  
Xingbao Blocks and DEMO Culture Company

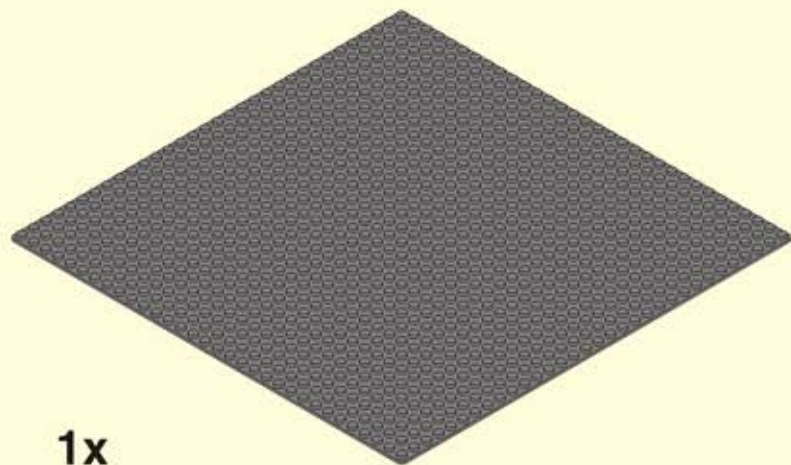

1x

+

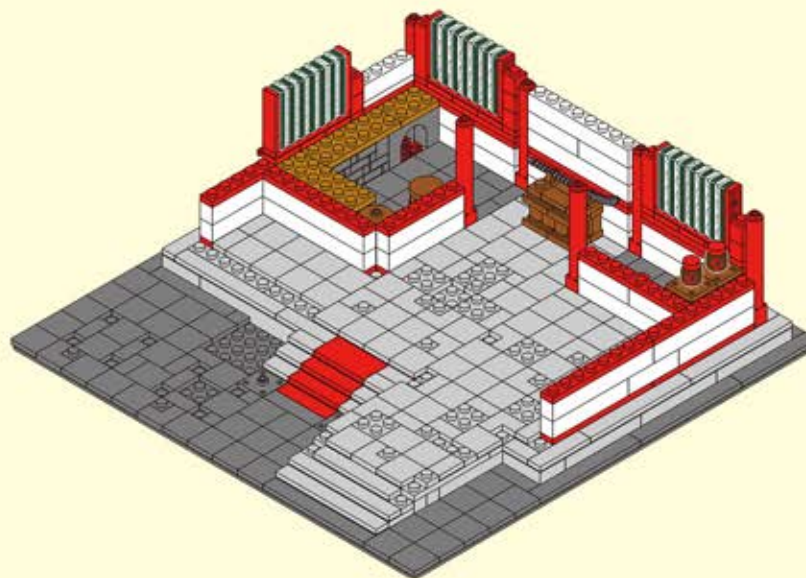

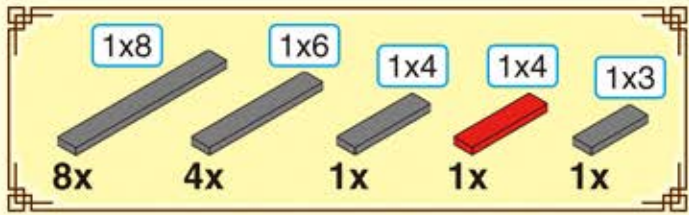

1-1

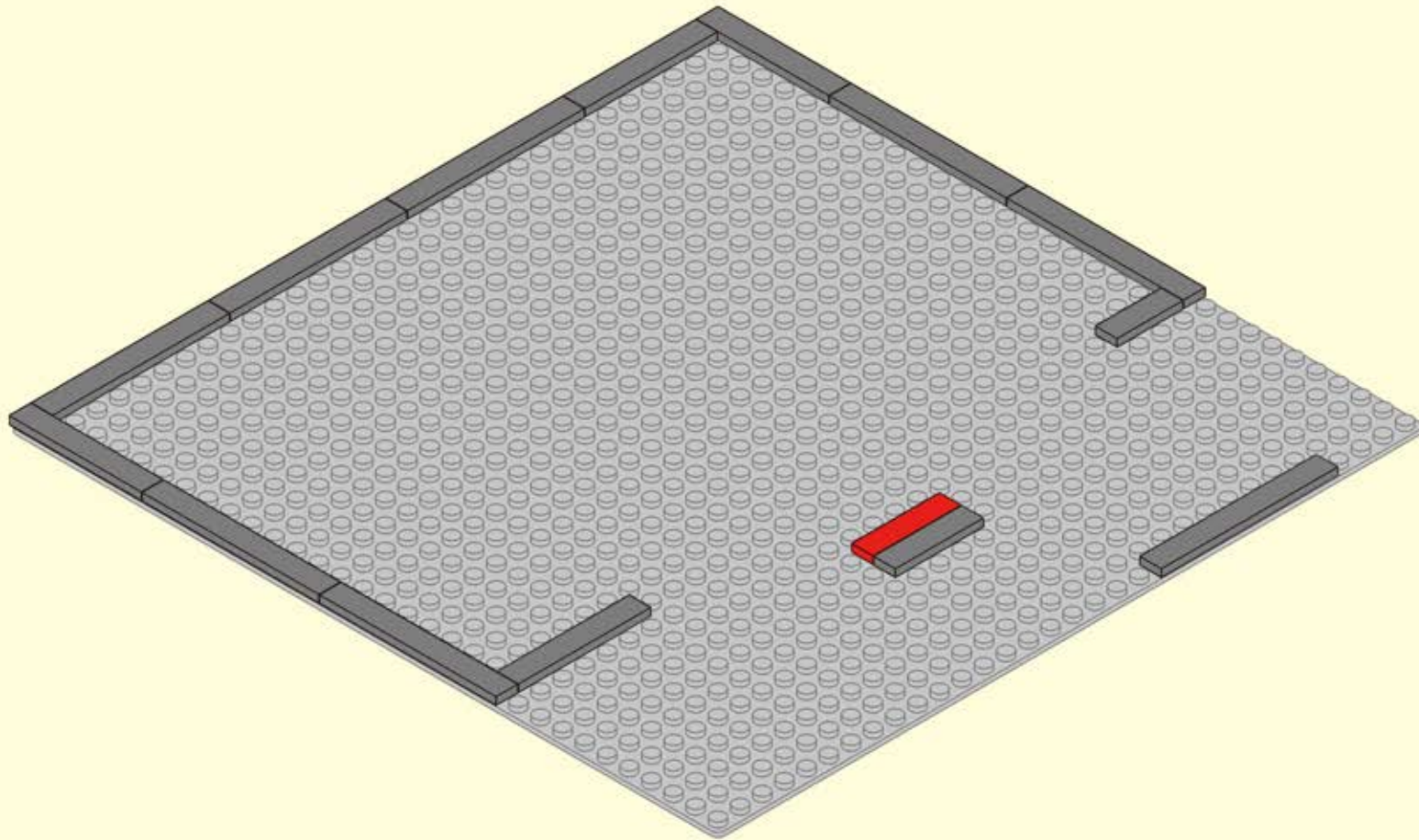

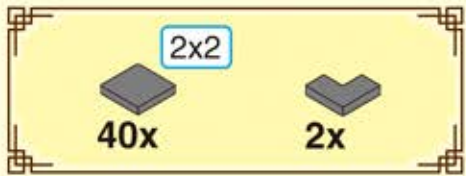

1-2

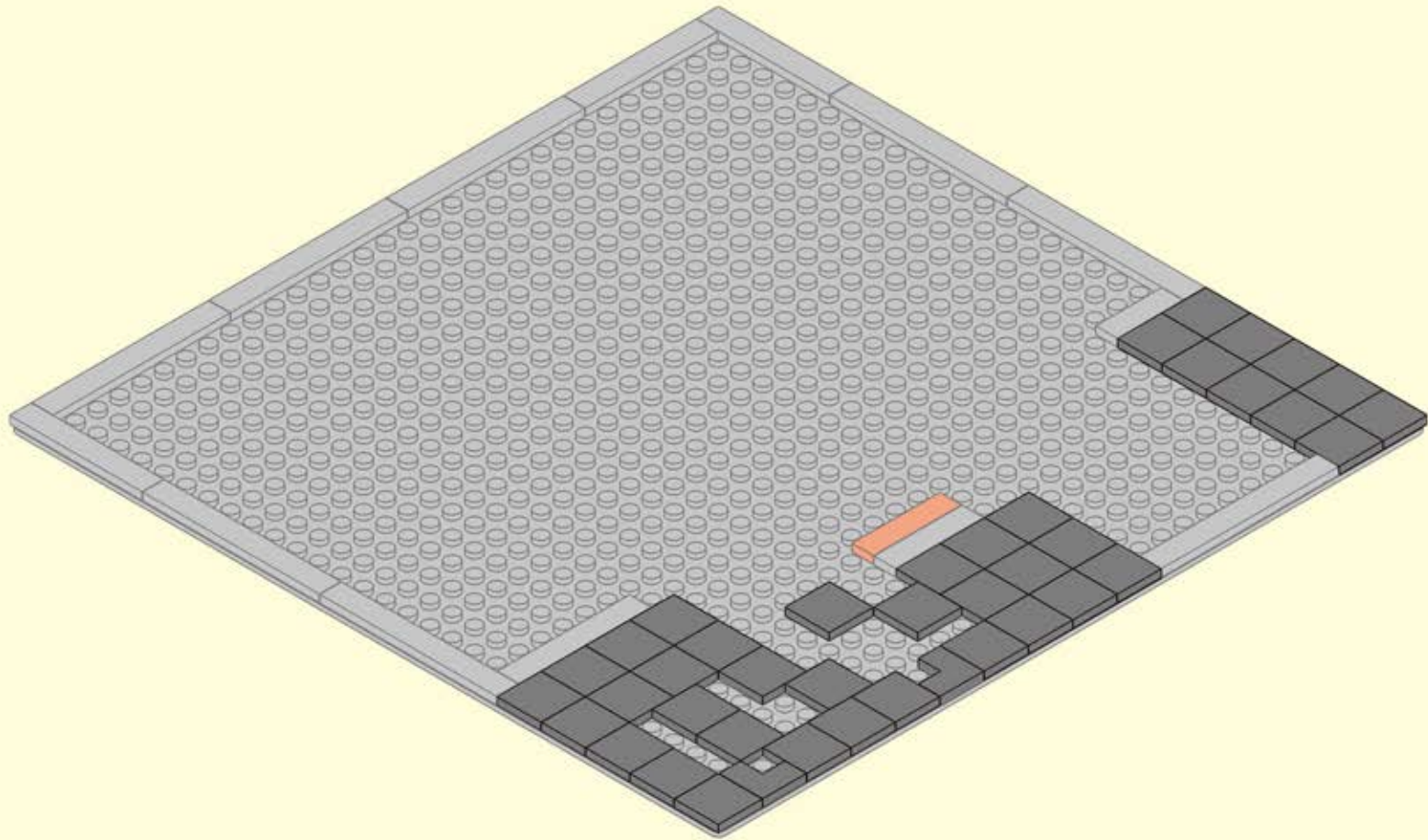

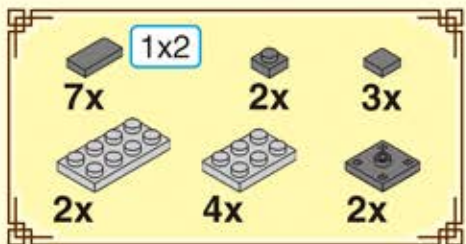

1-3

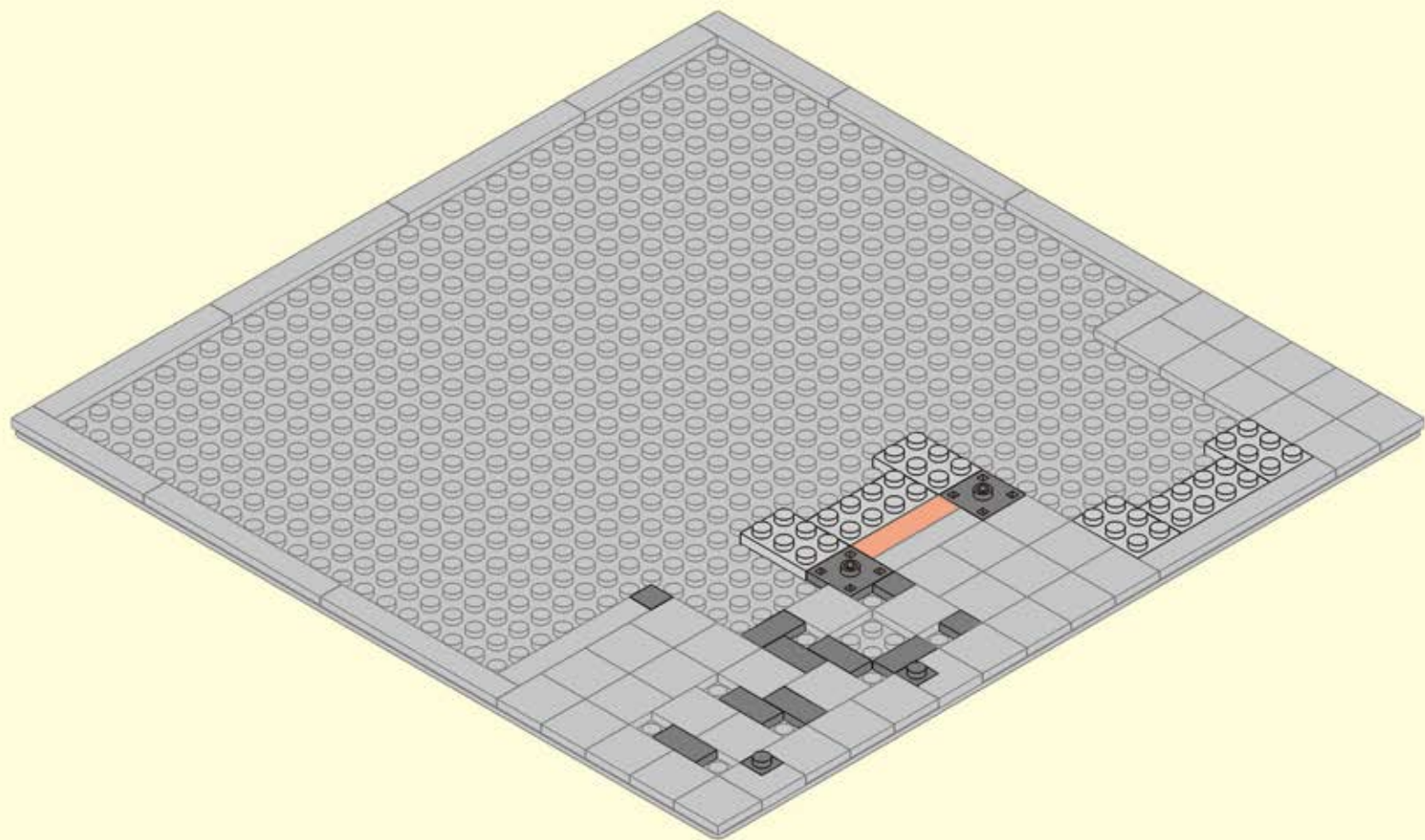

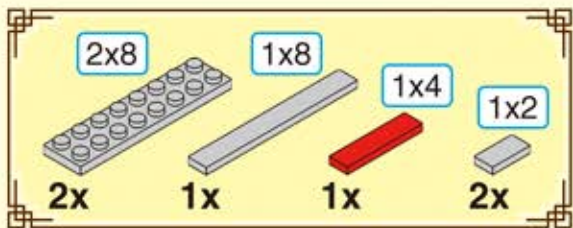

1-4

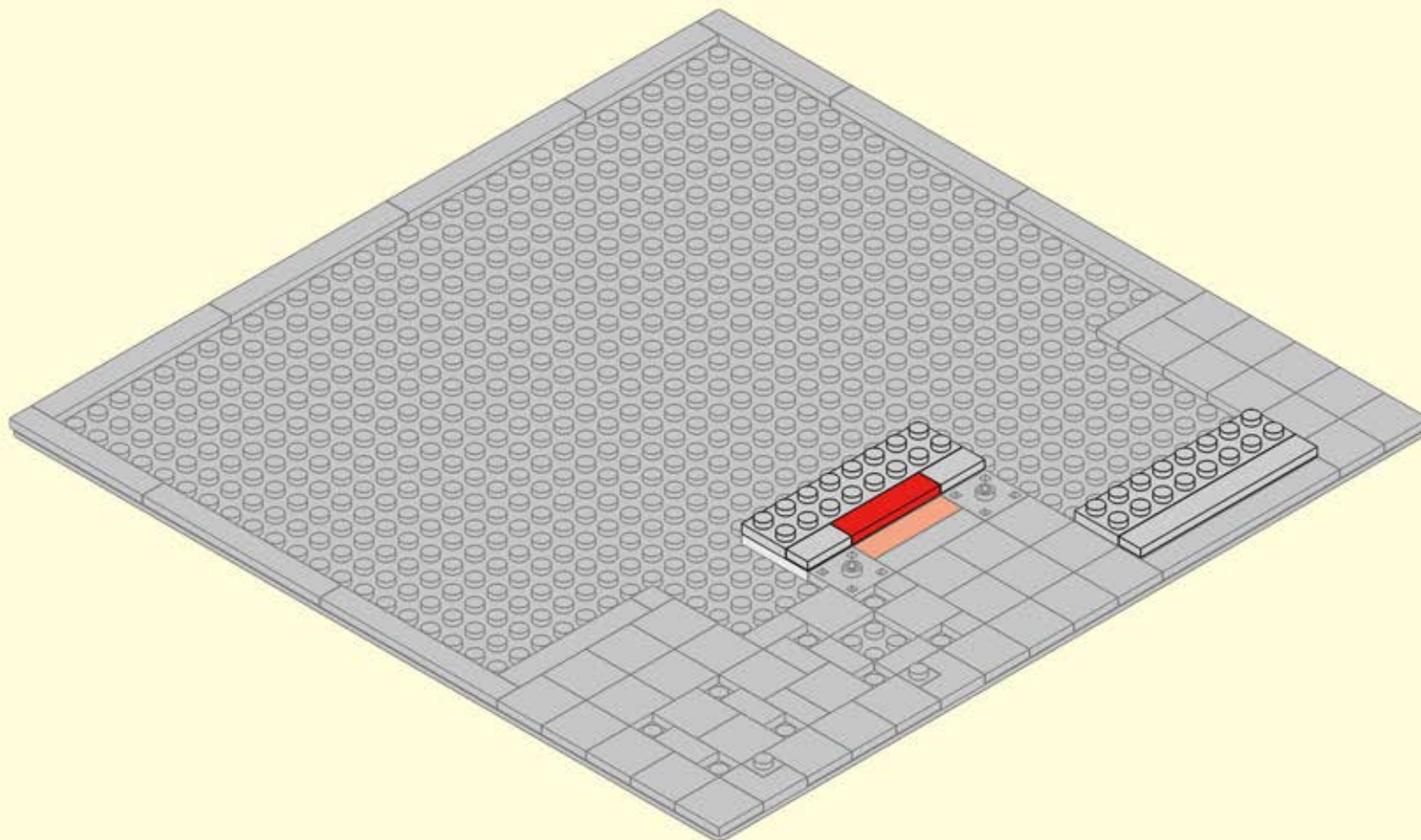

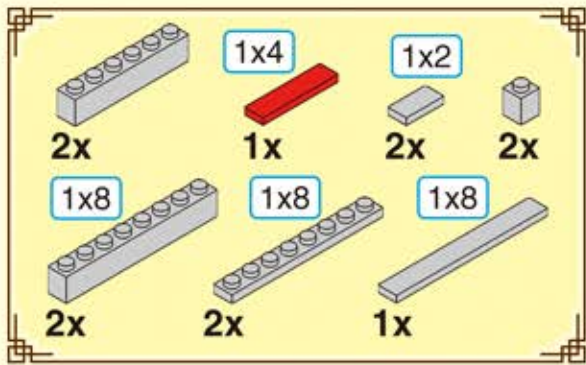

1-5

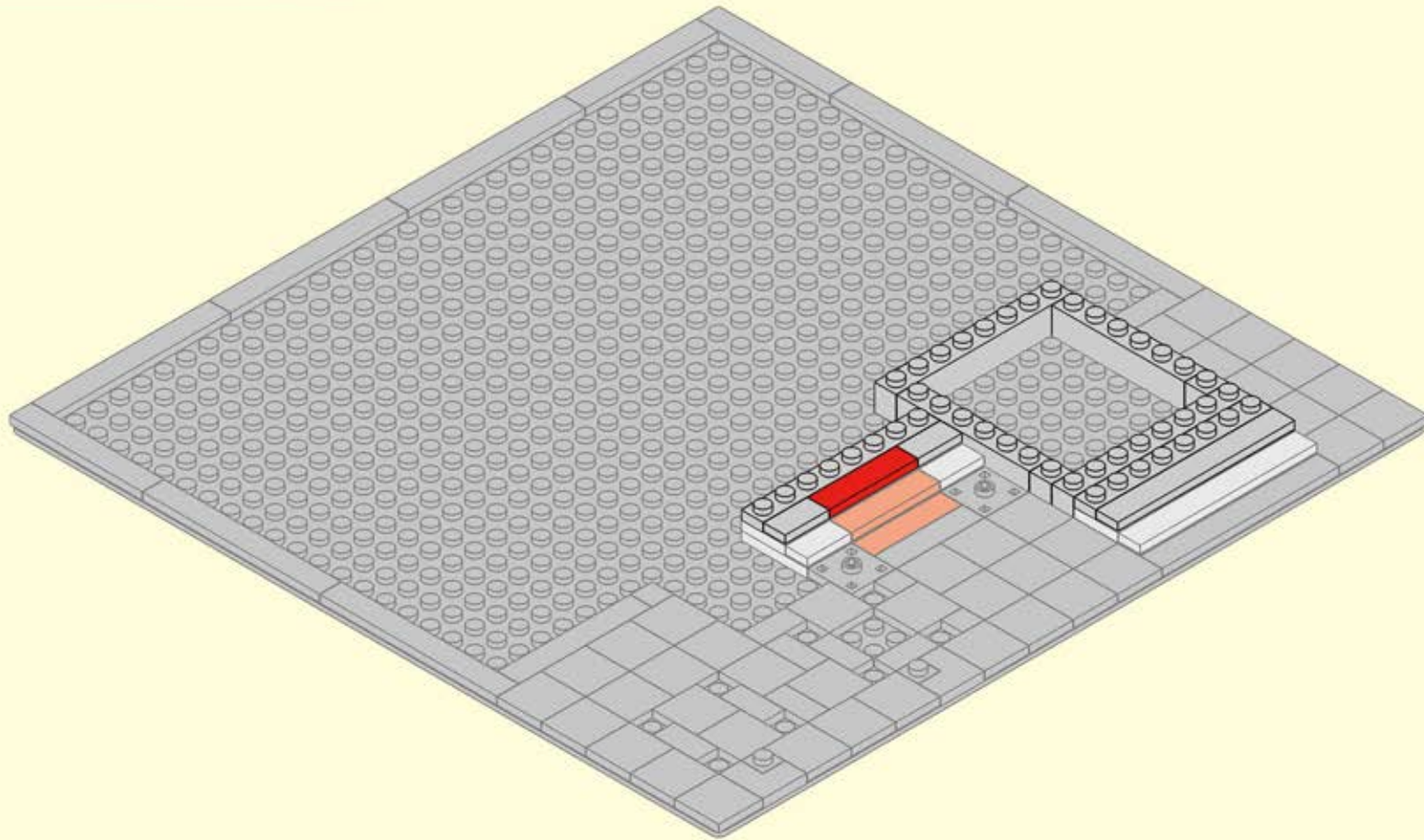

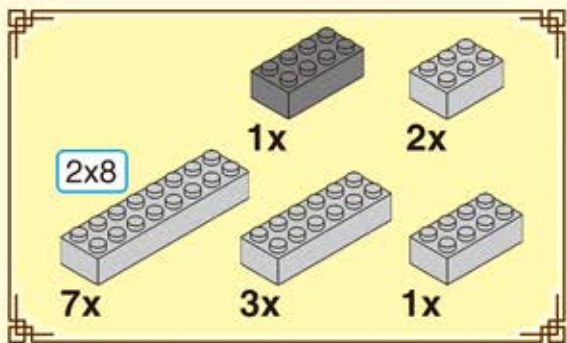

1-6

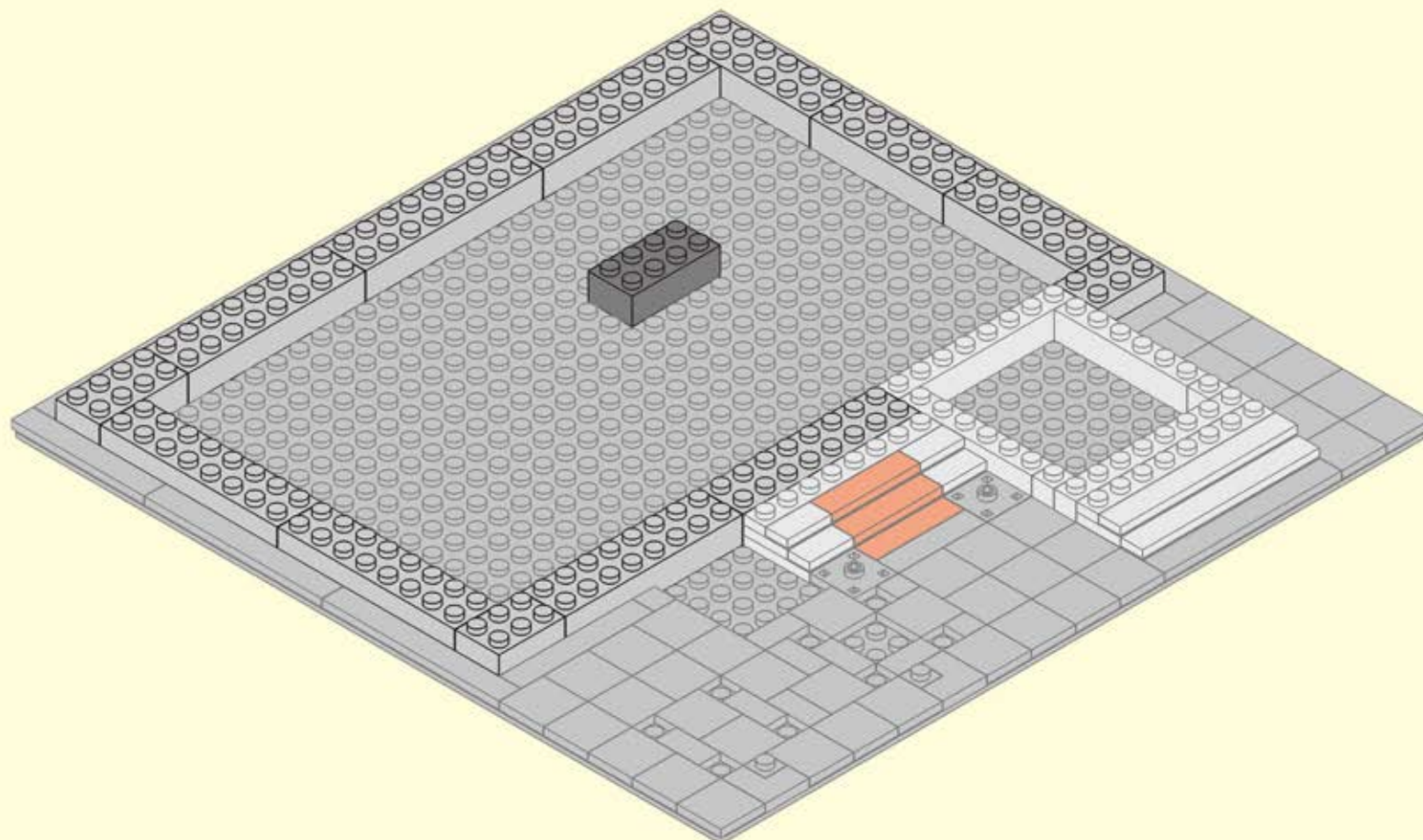

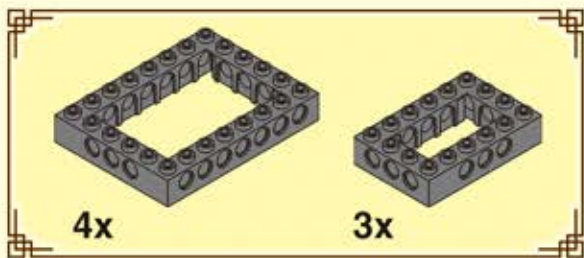

1-7

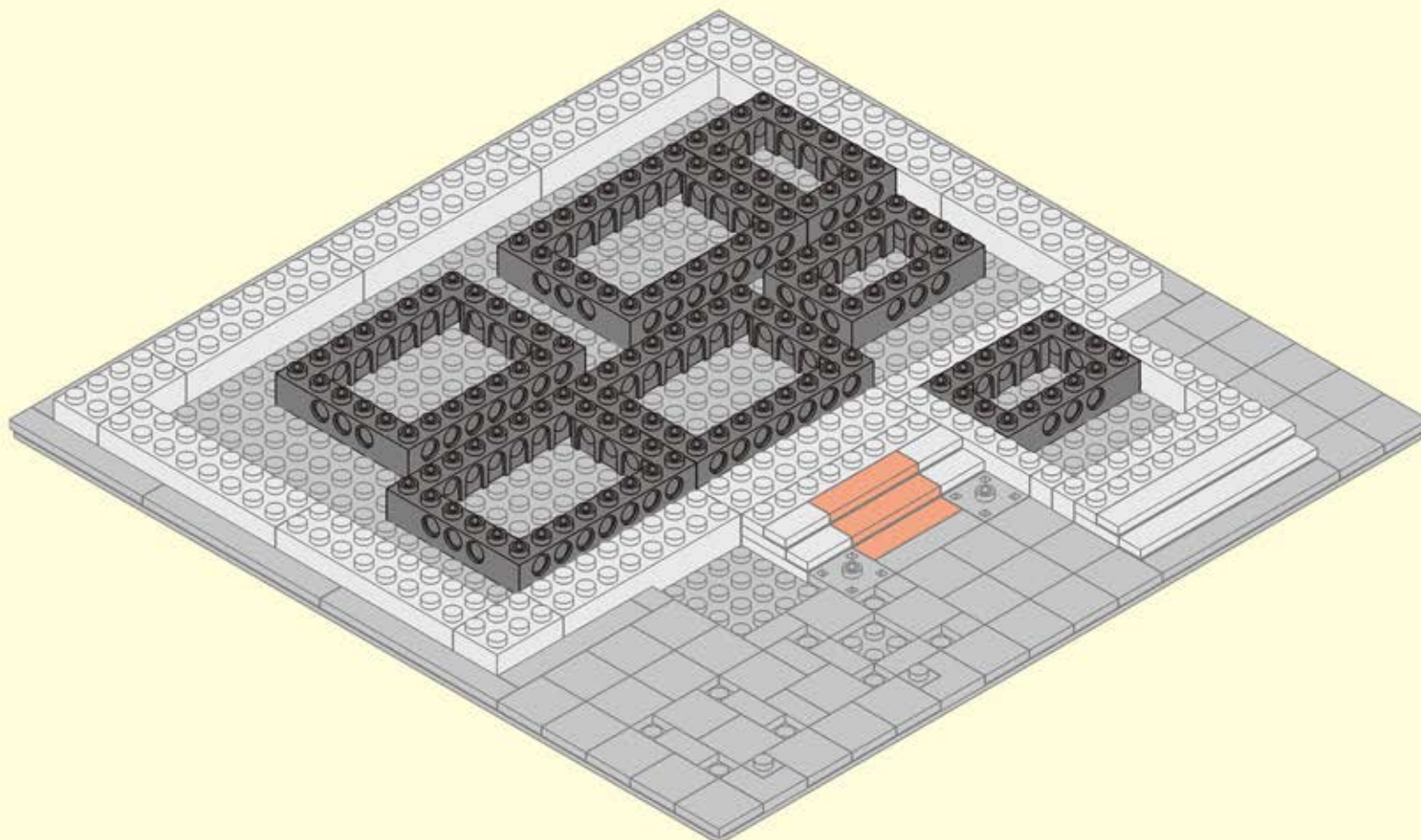

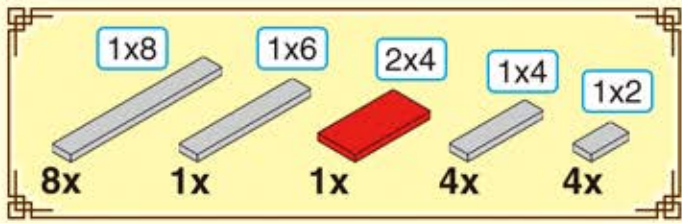

1-8

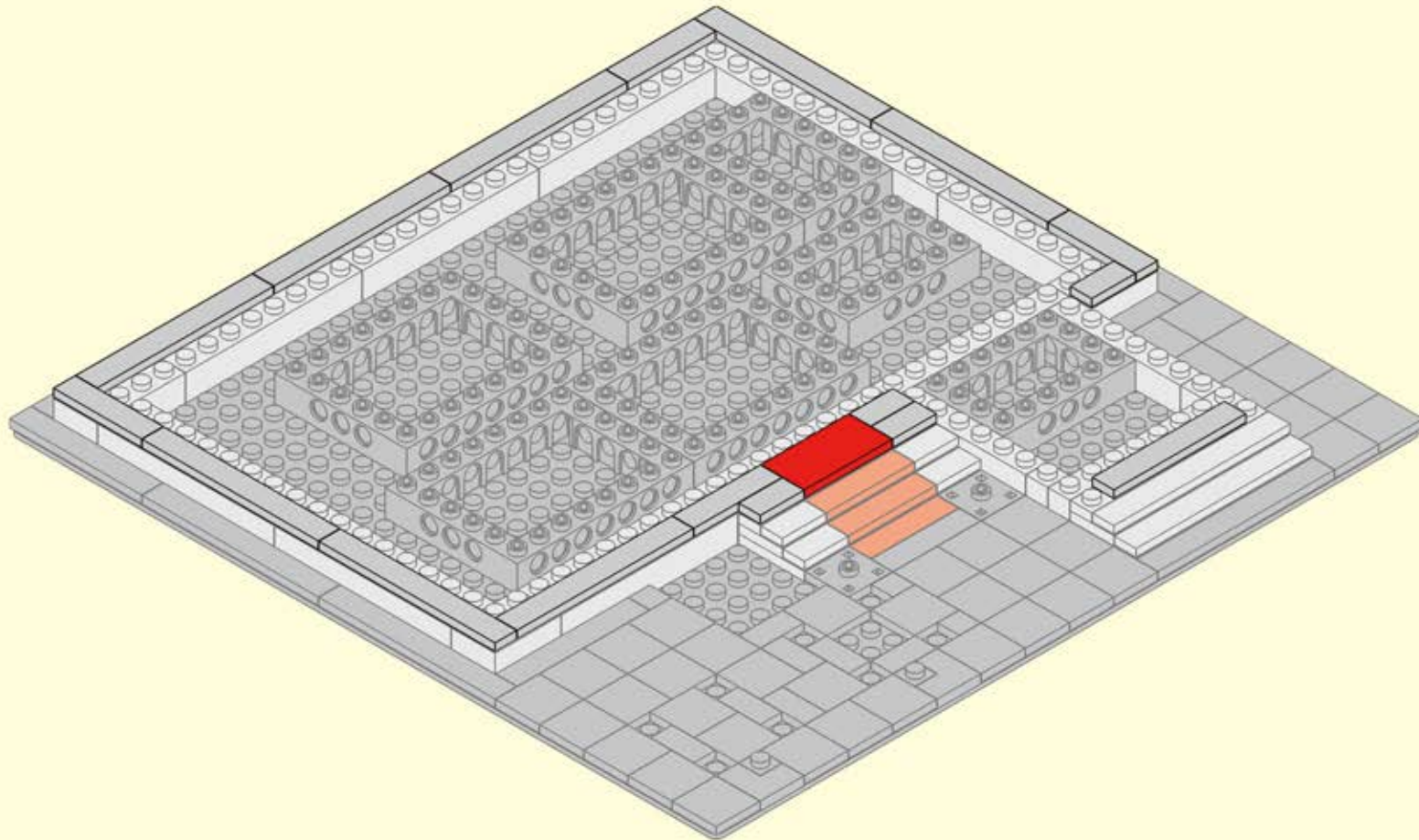

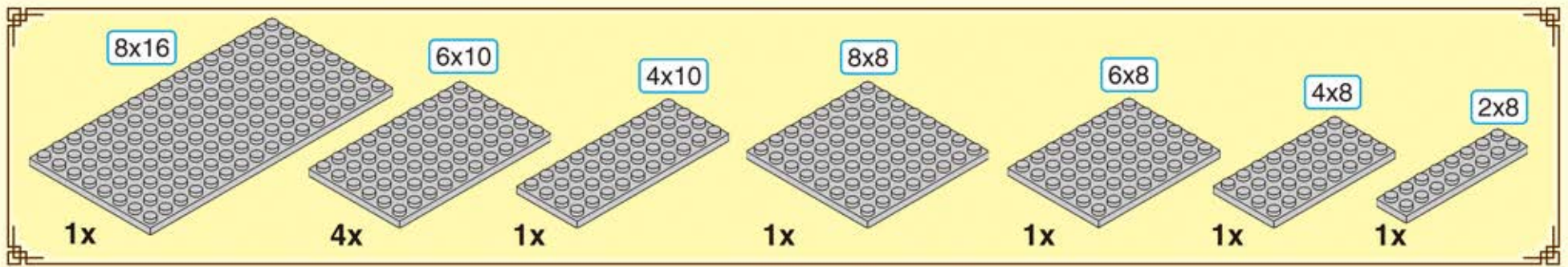

1-9

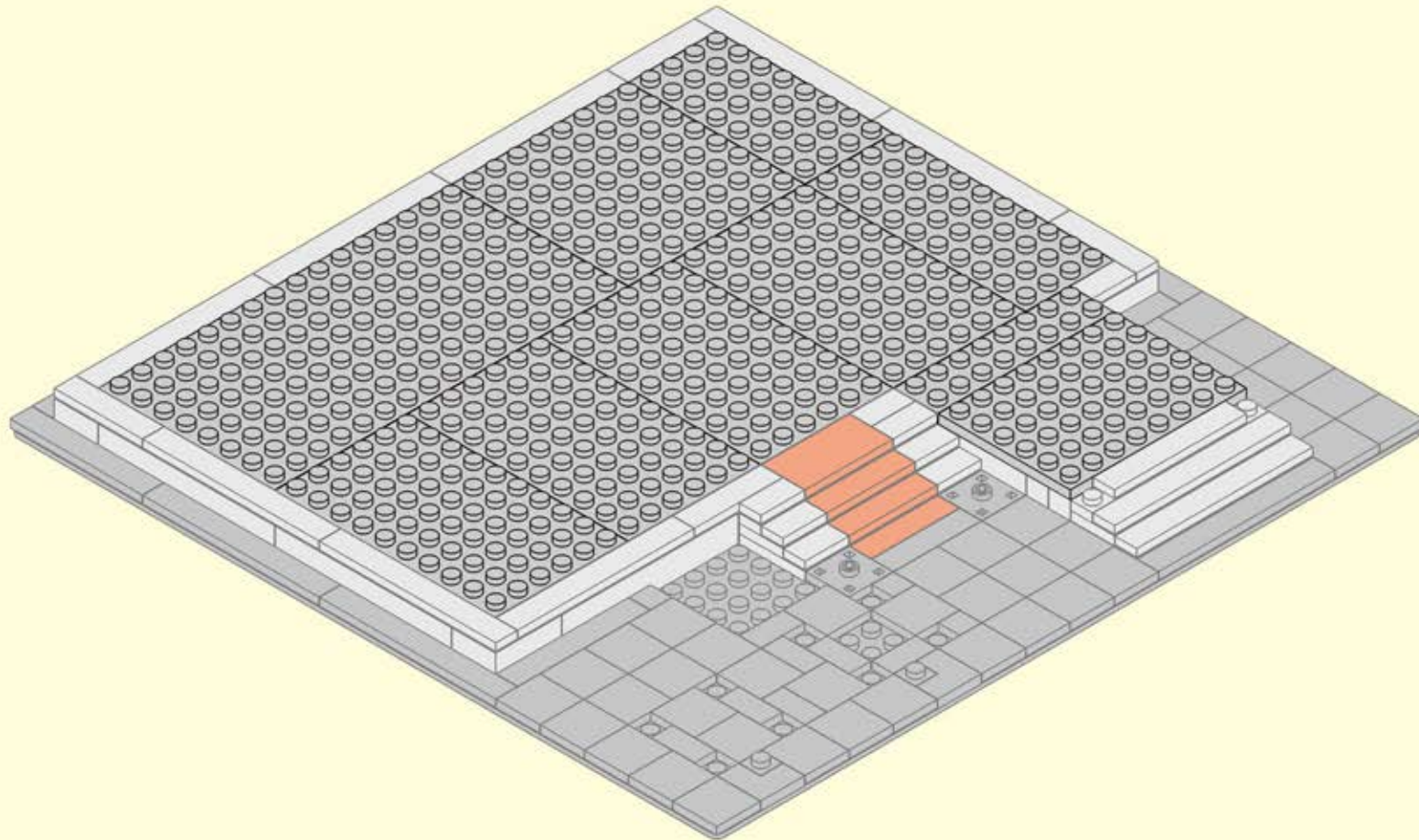





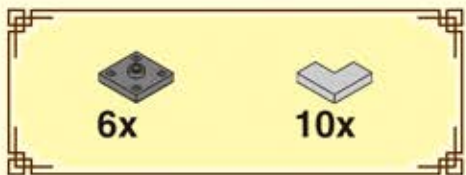

1-12

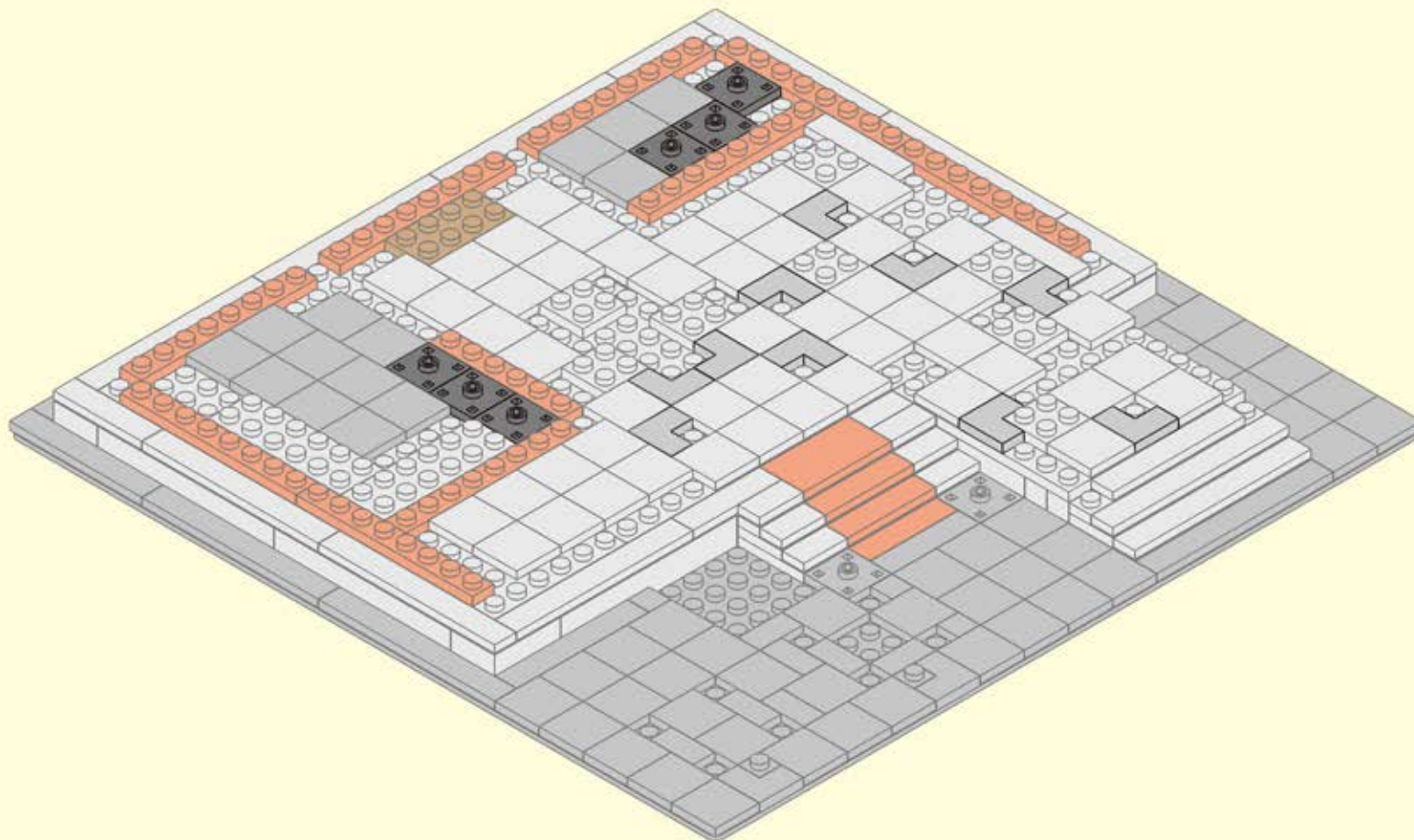

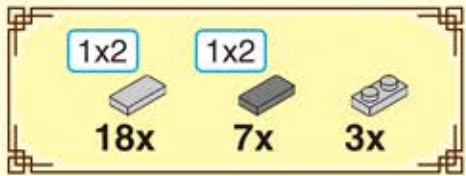

1-13

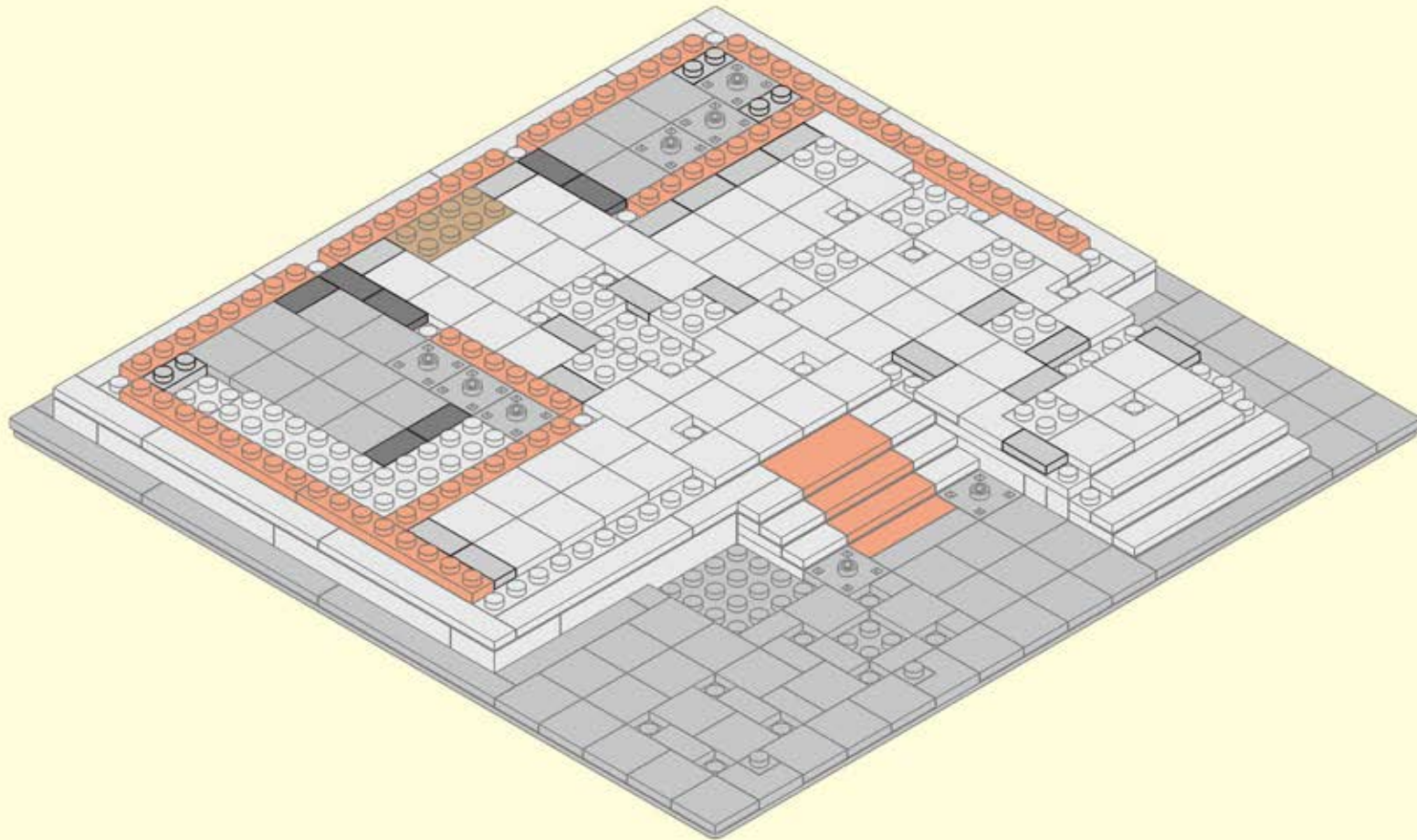



1-14

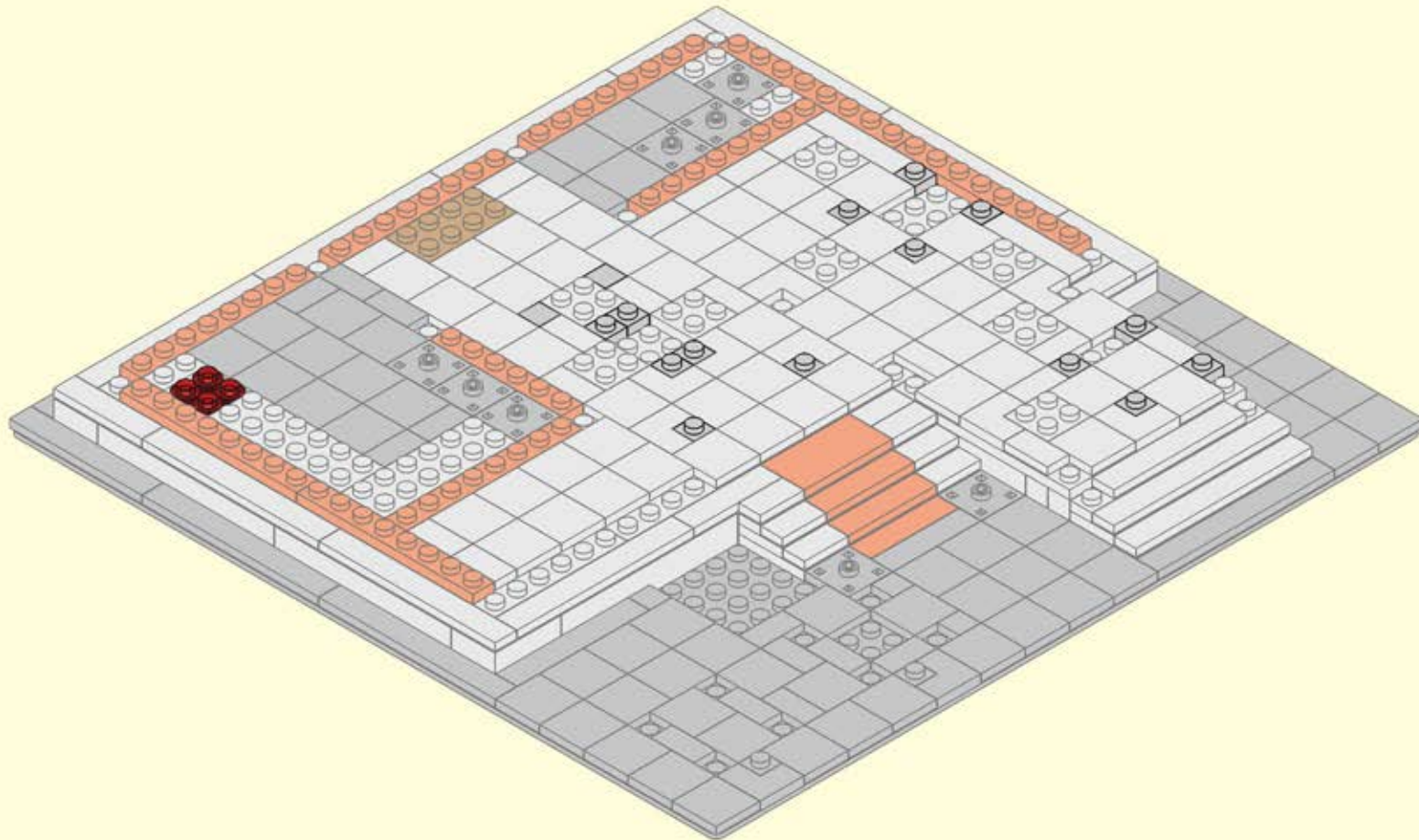

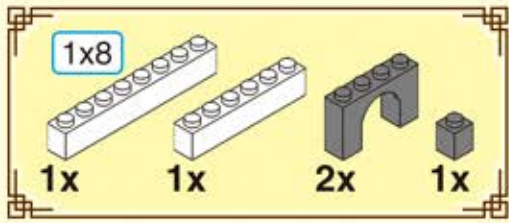

1-15

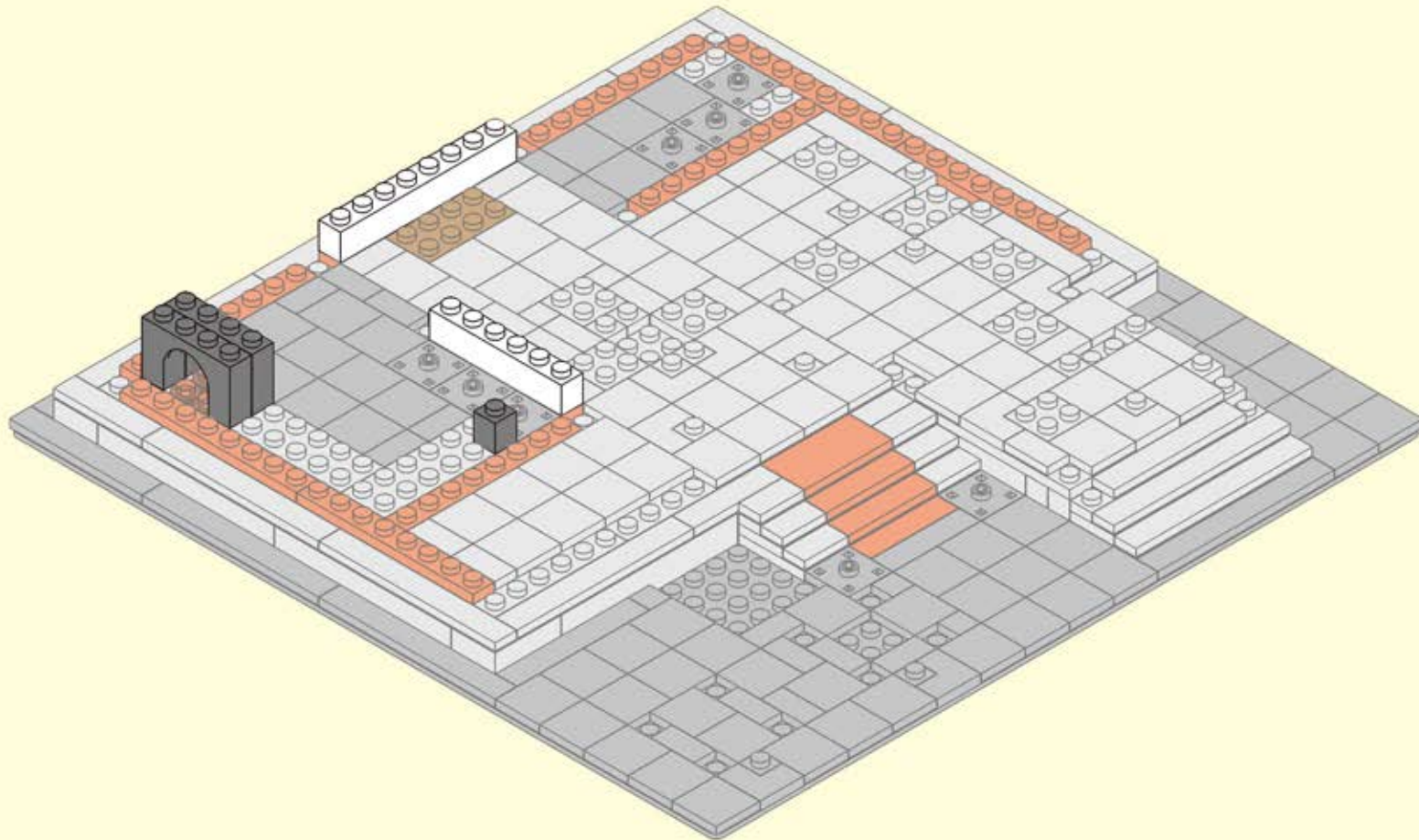

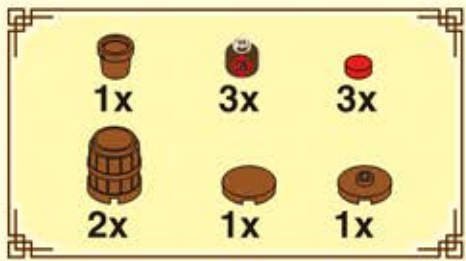

1-16

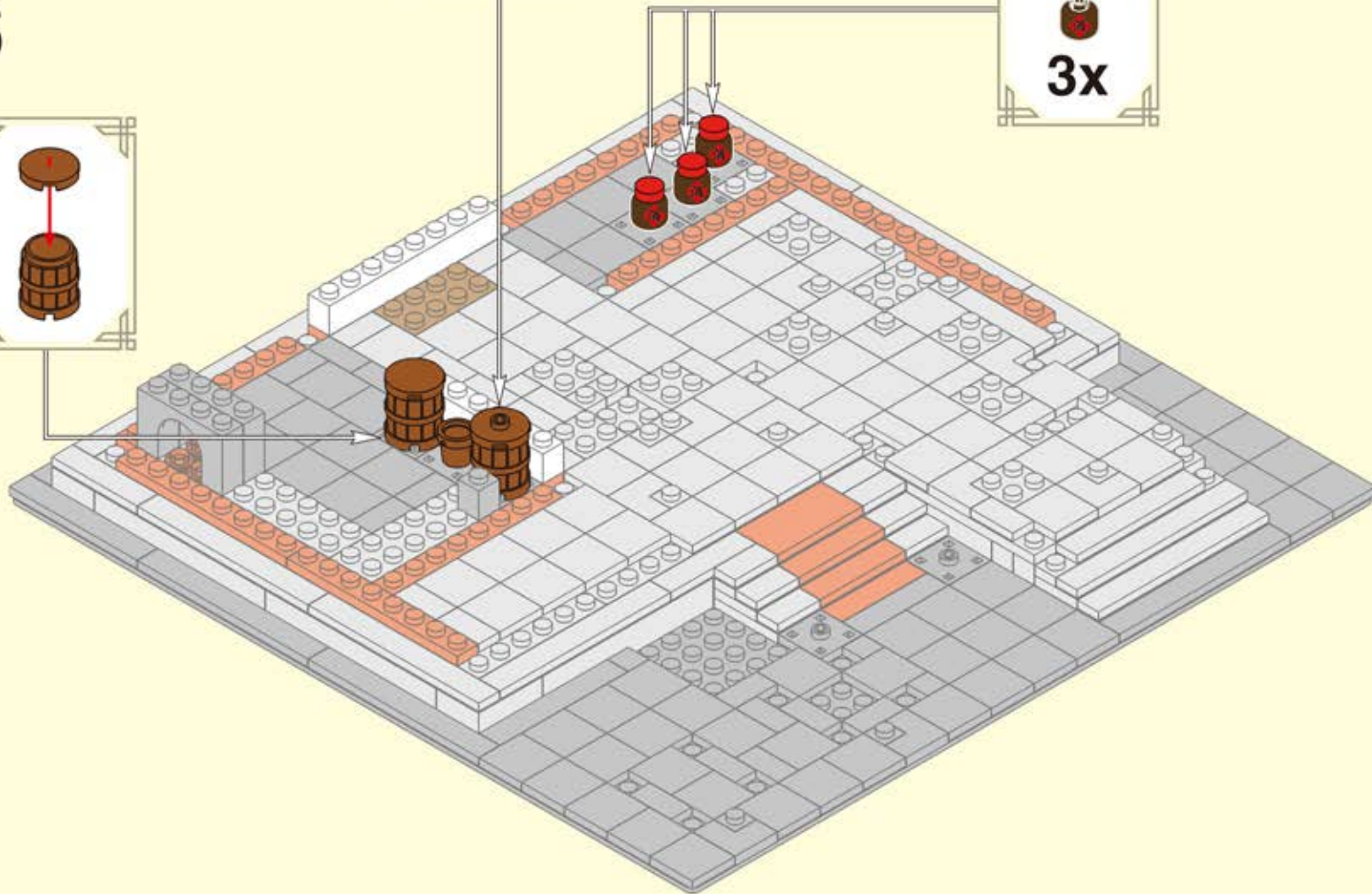





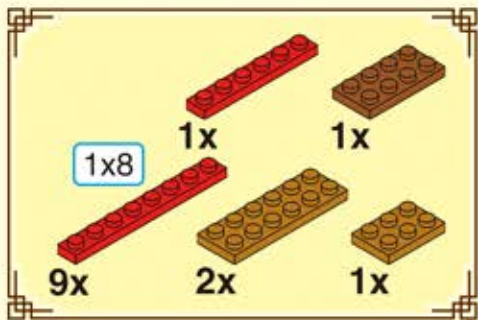

1-19

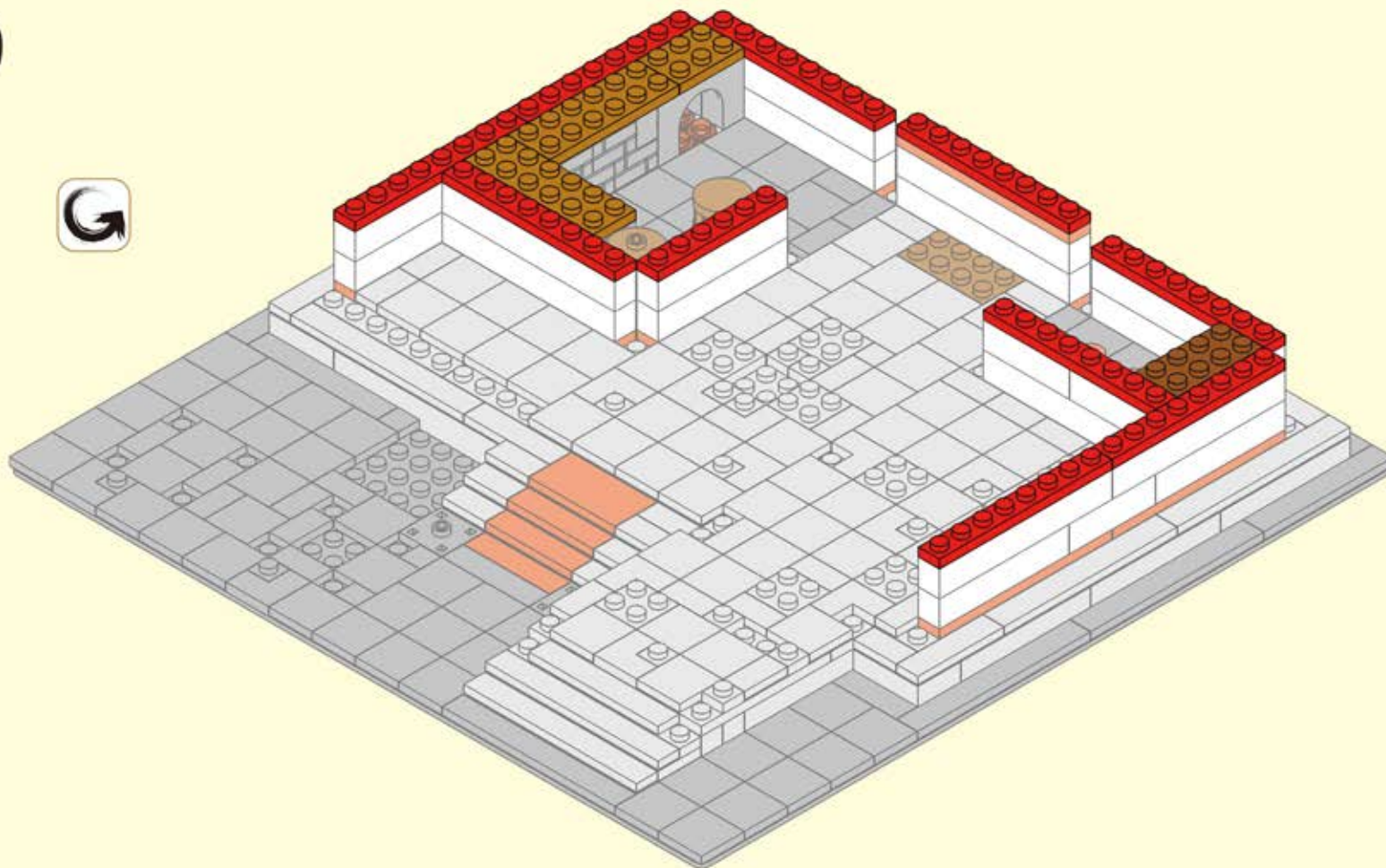

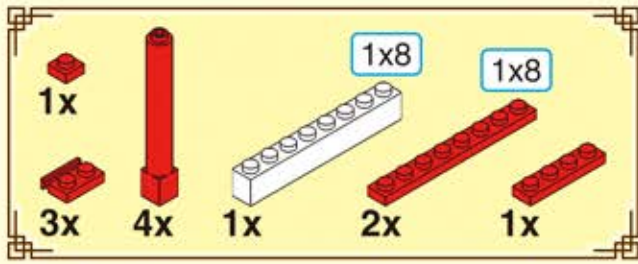

1-20

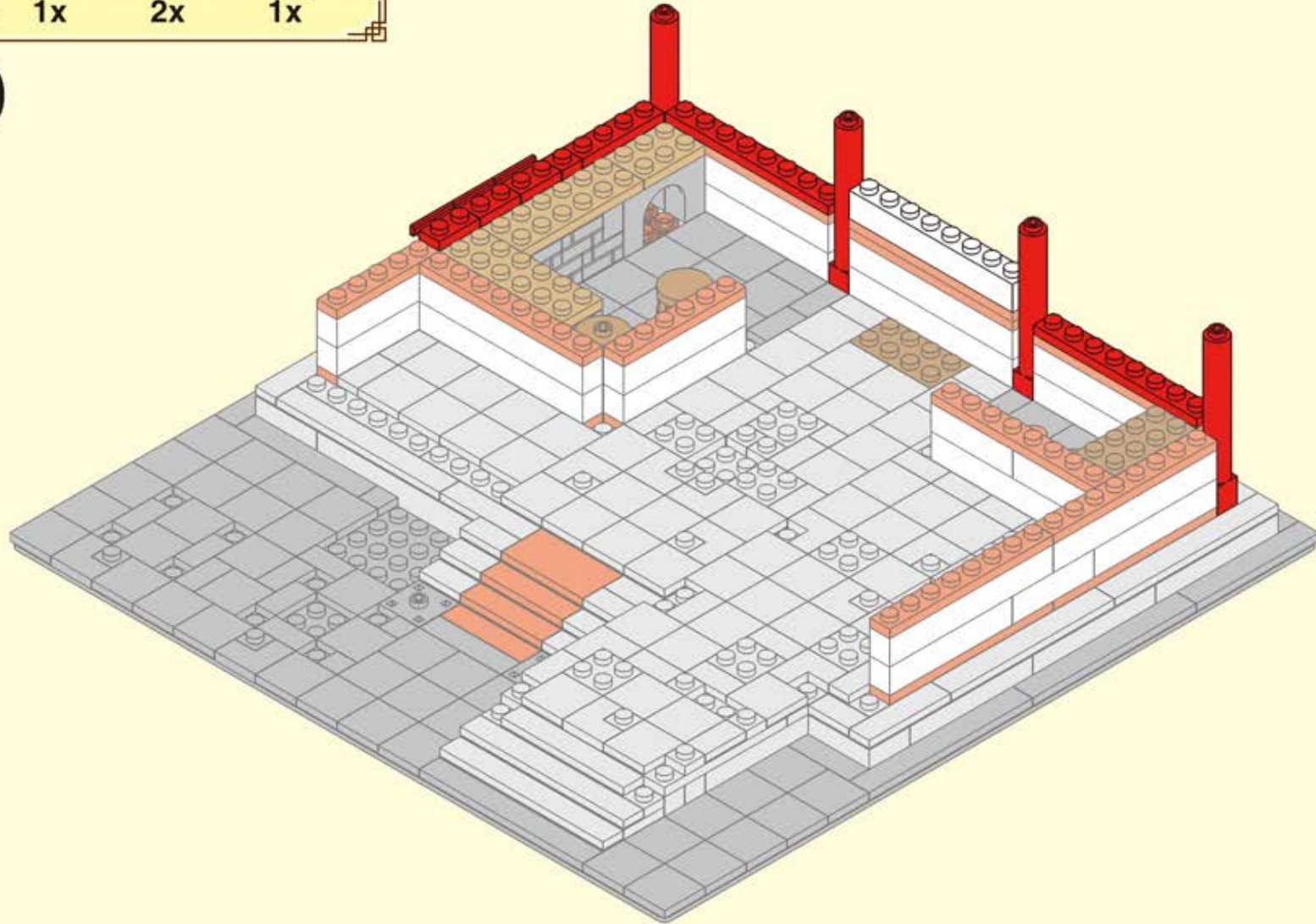

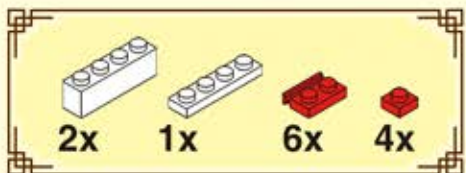

1-21

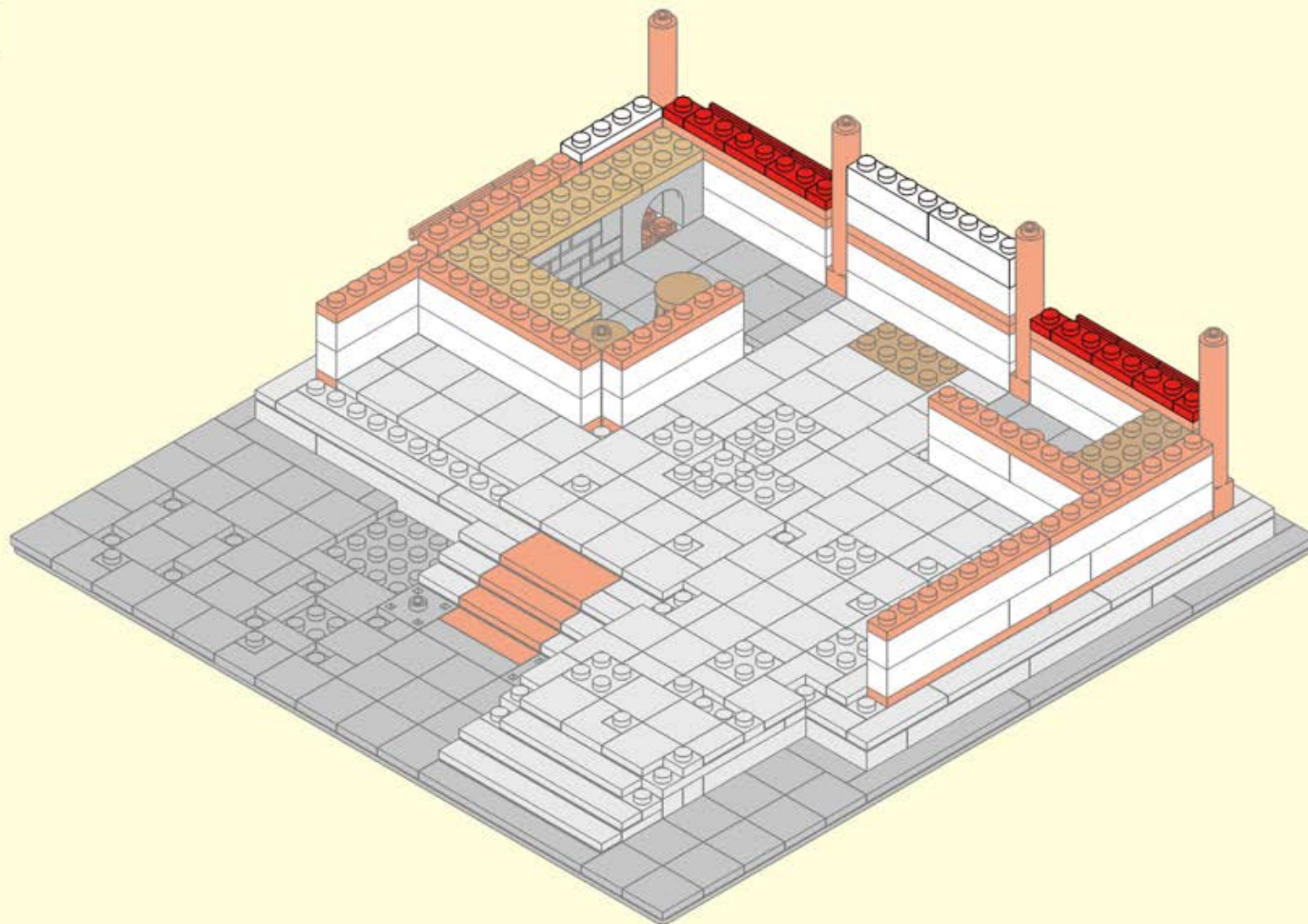

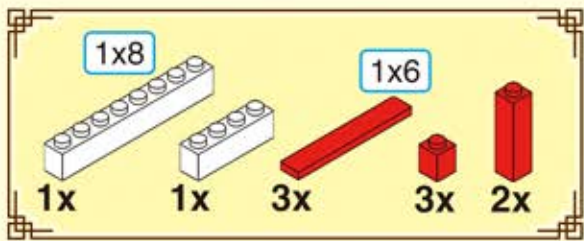

1-22

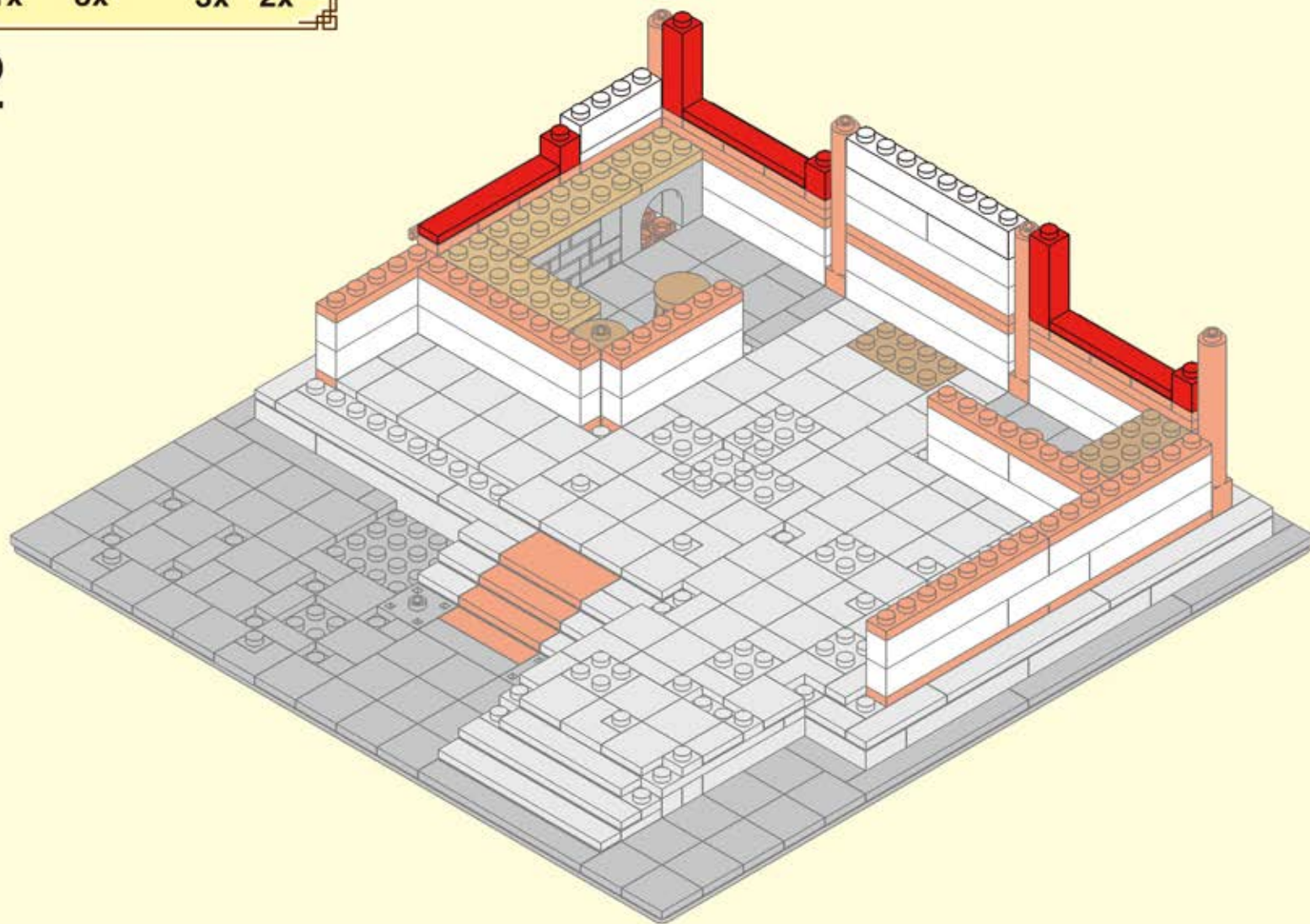

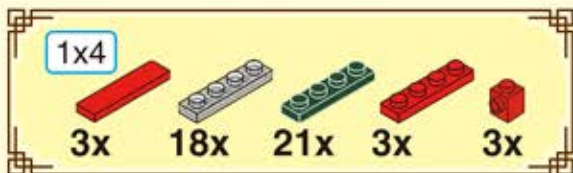

# 1-23

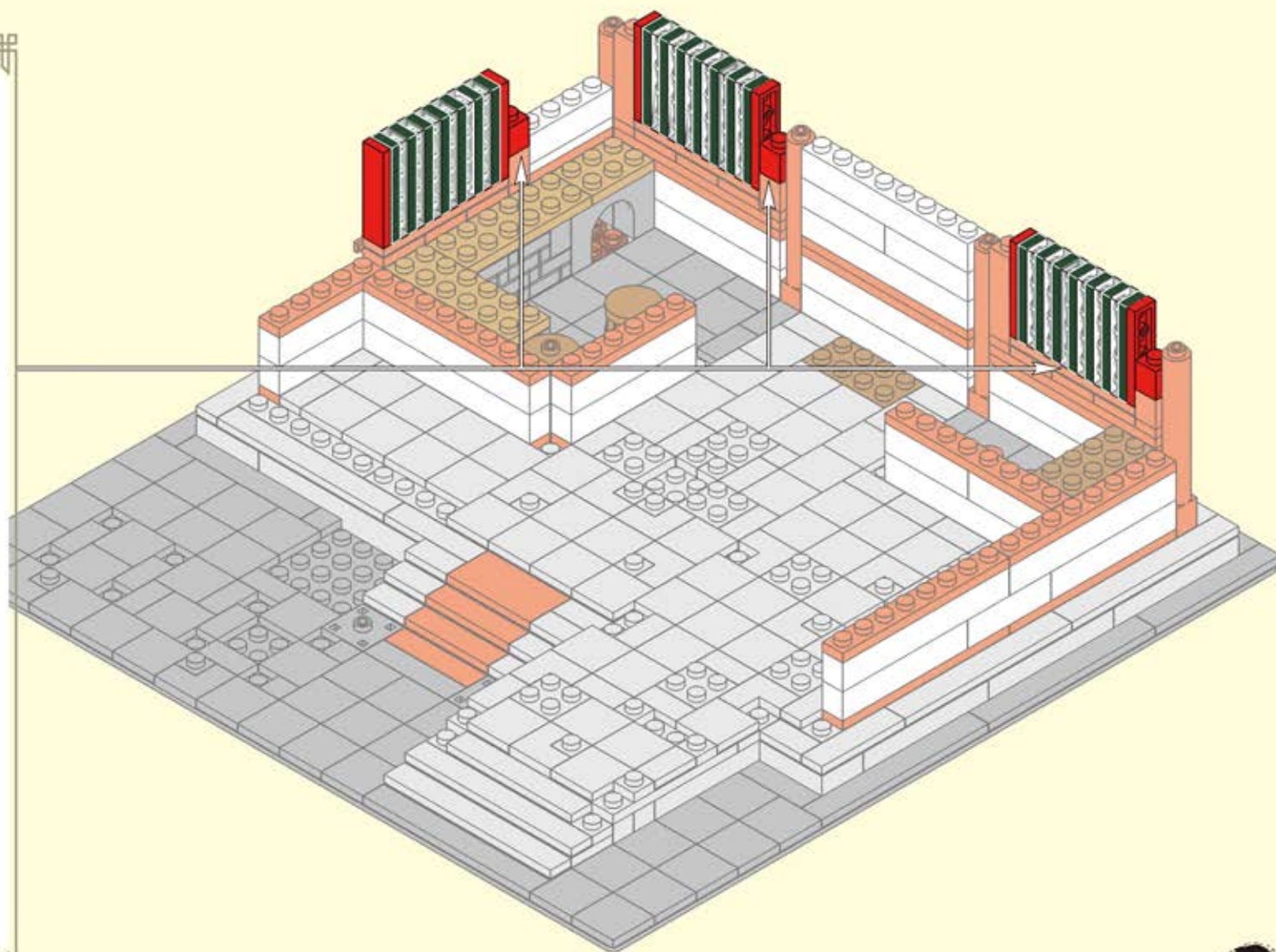
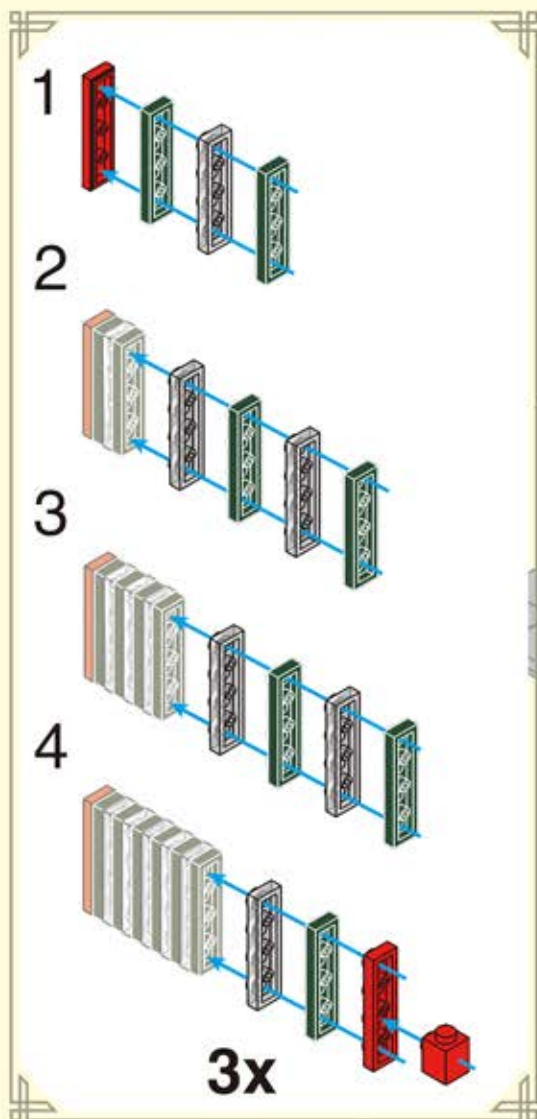

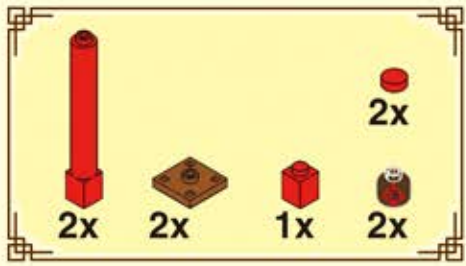

1-24

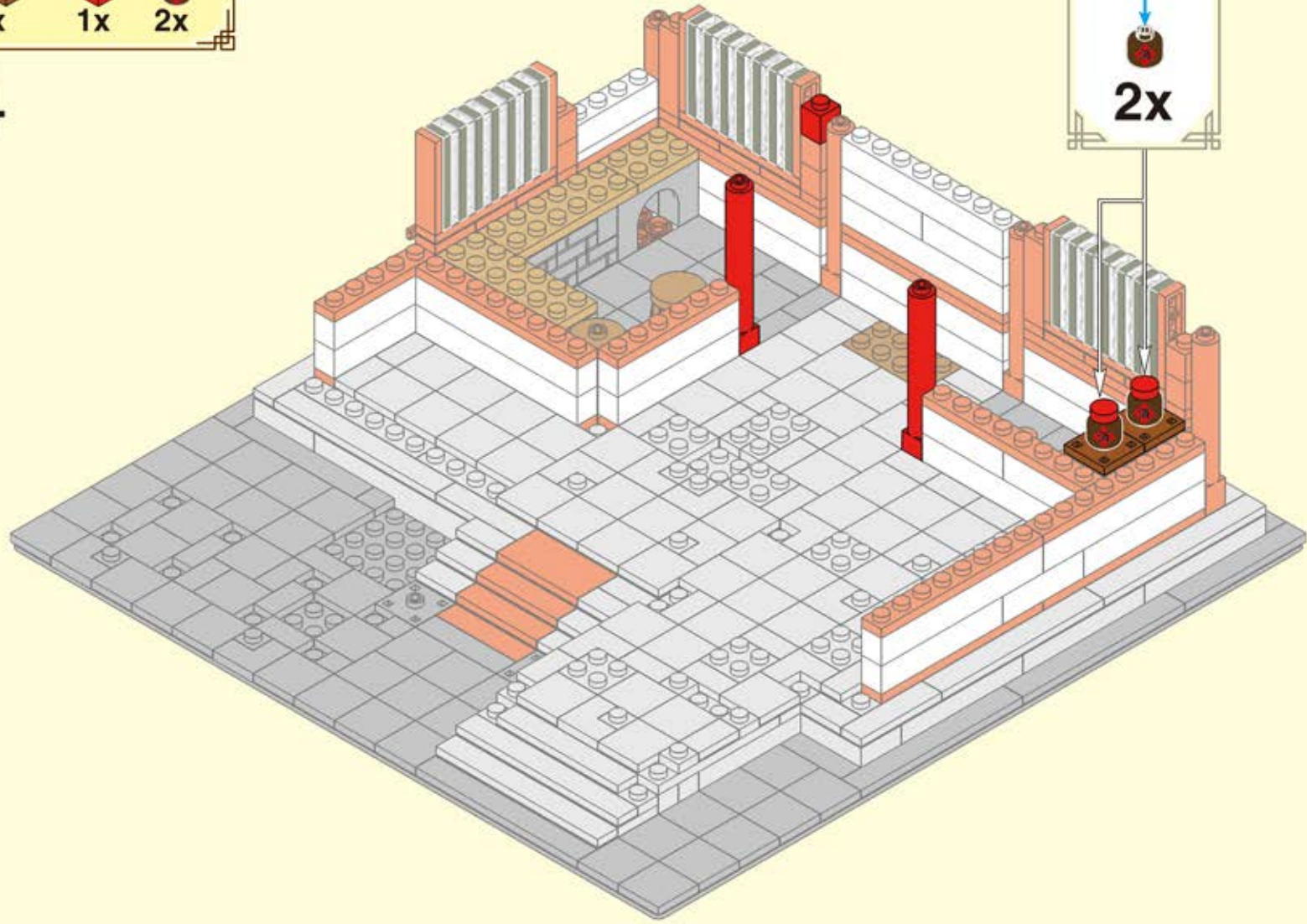

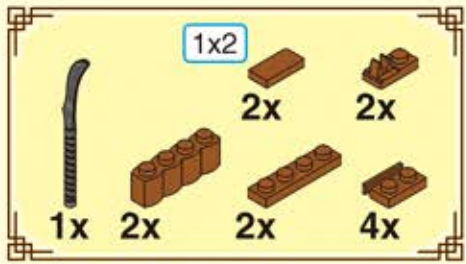

1-25

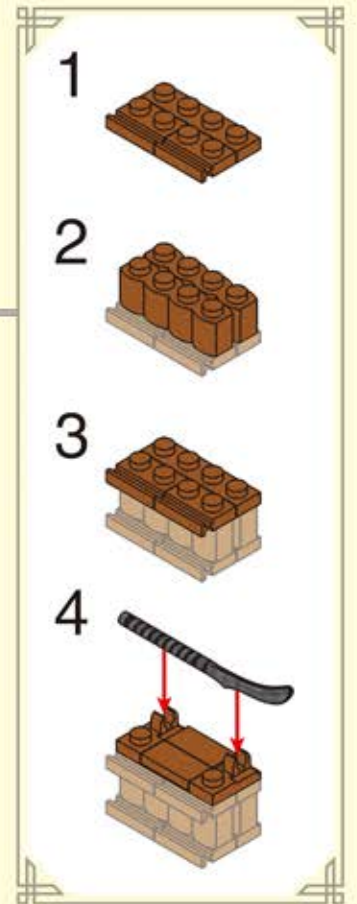
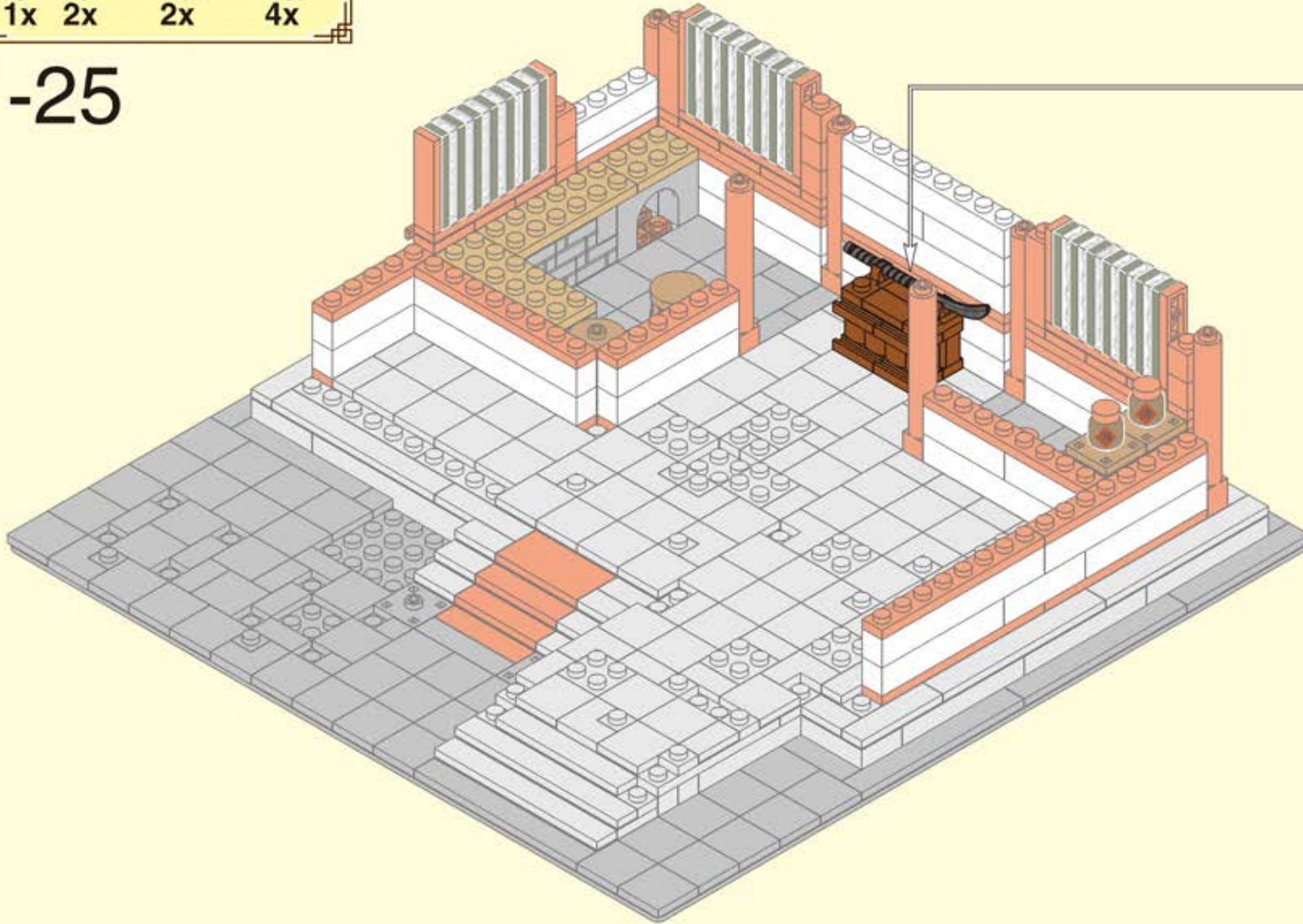



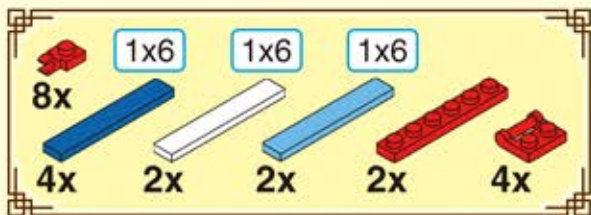

# 2-1

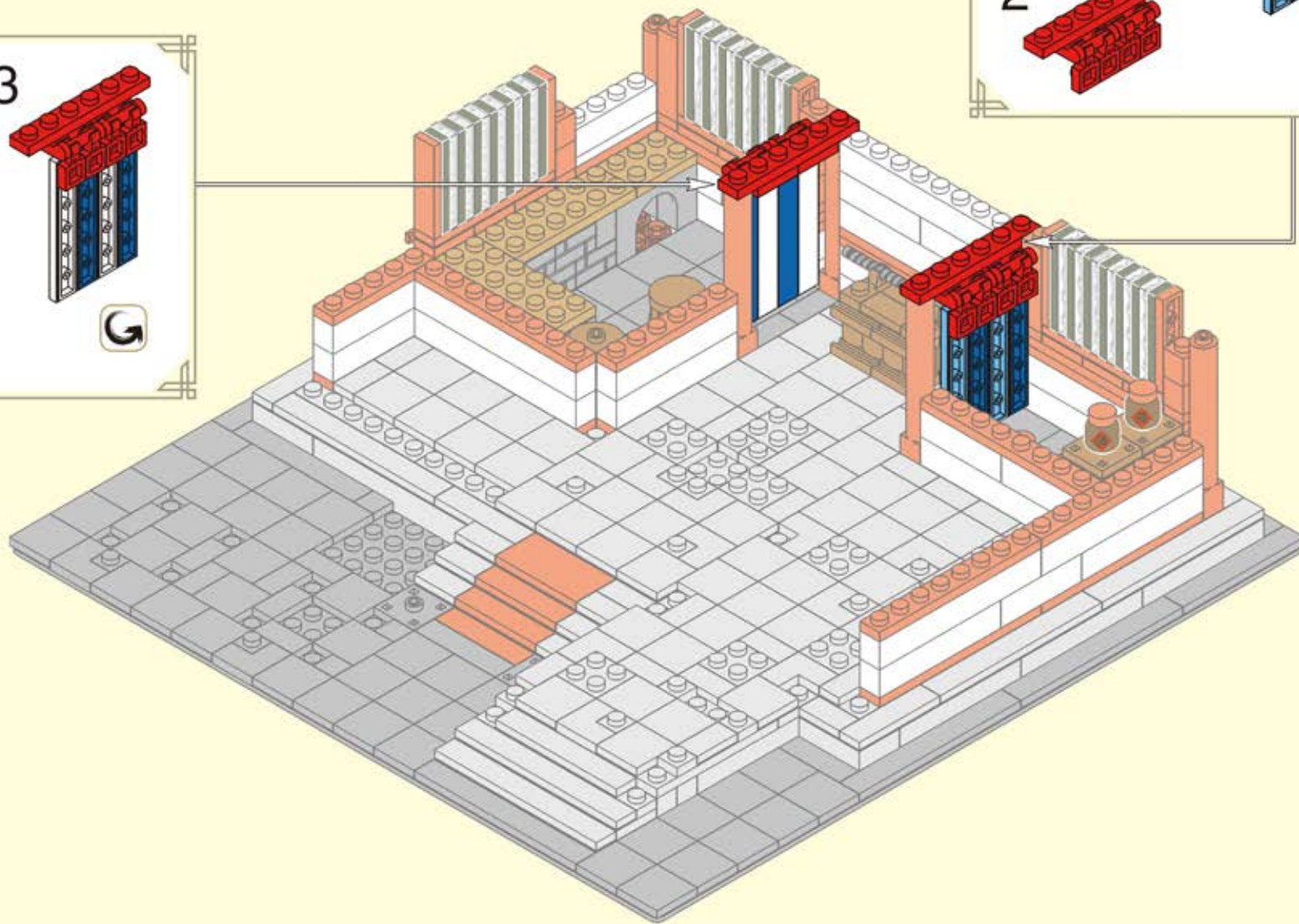
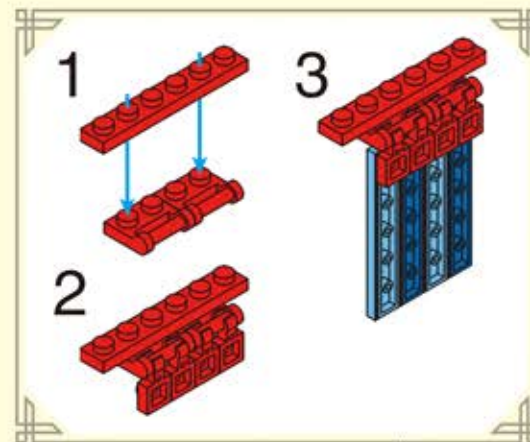
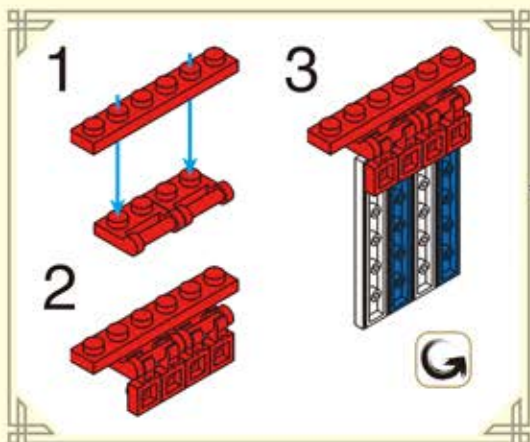

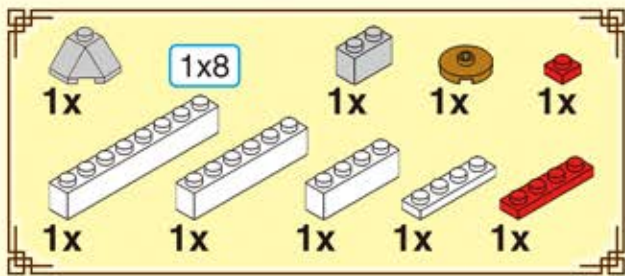

2-2

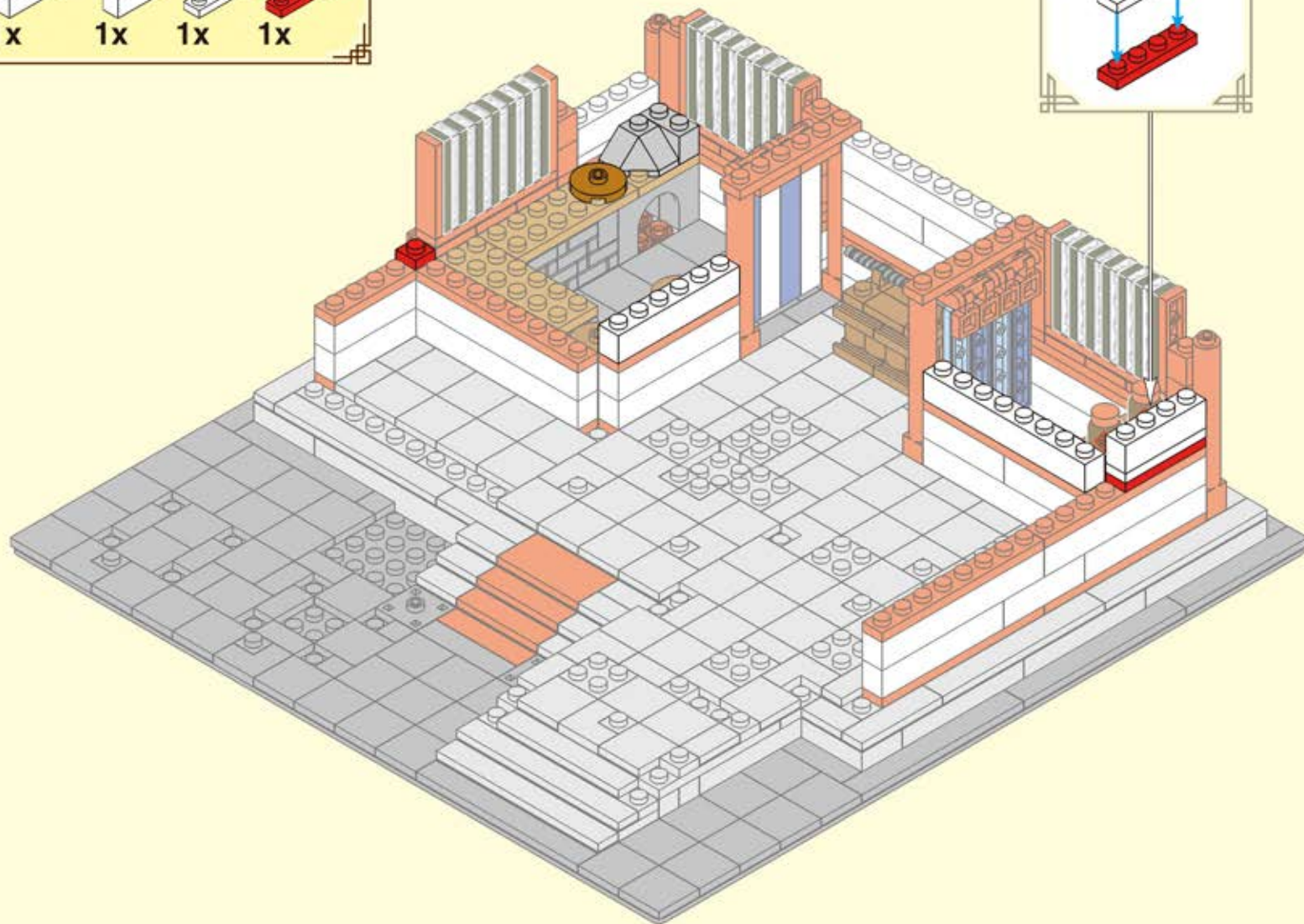
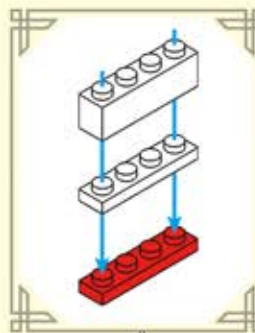

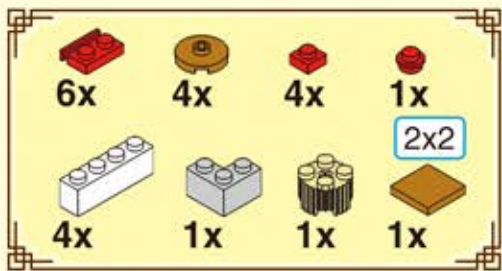

2-3

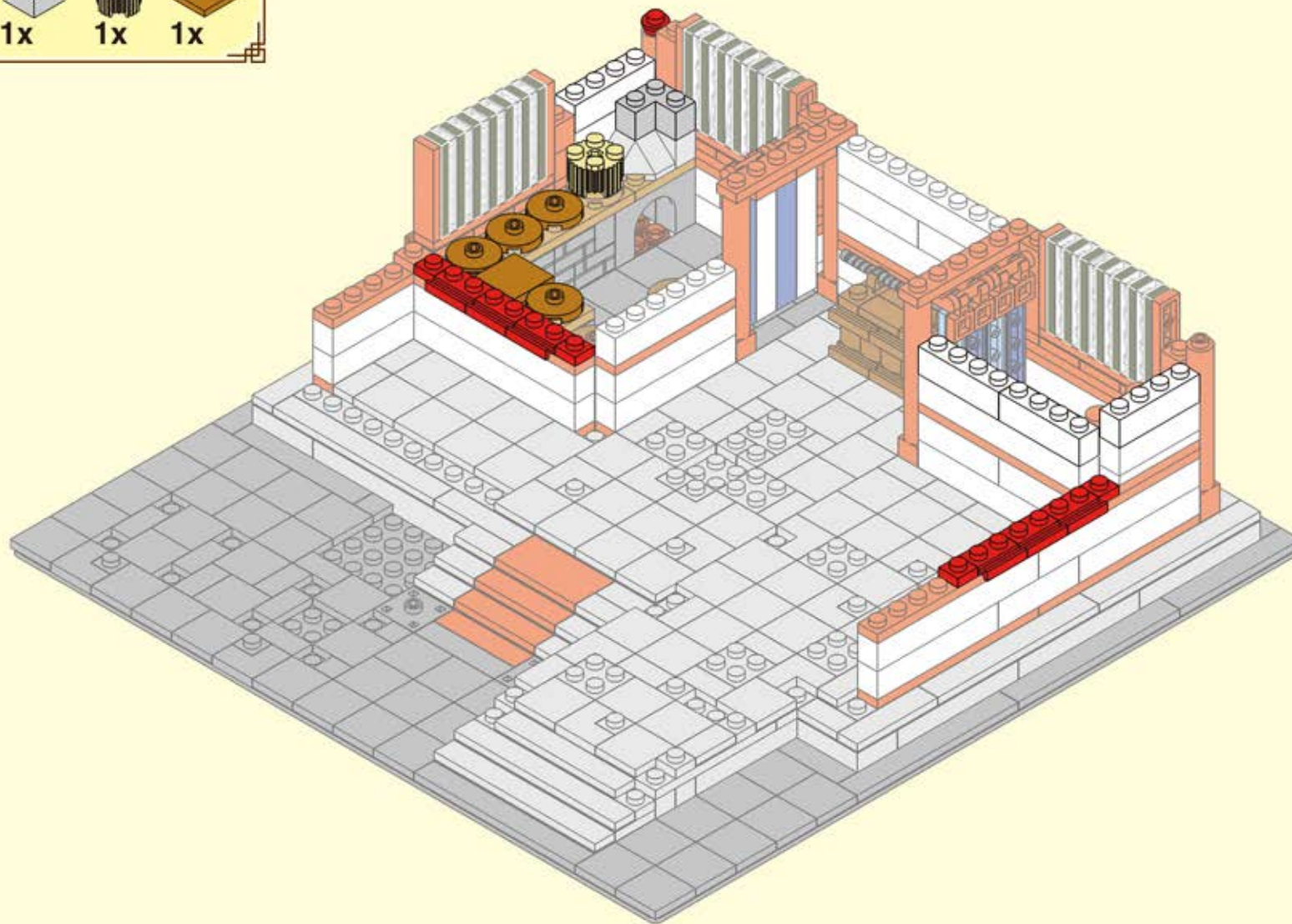

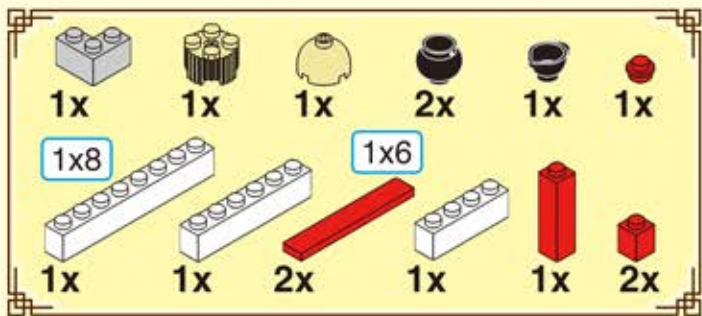

2-4

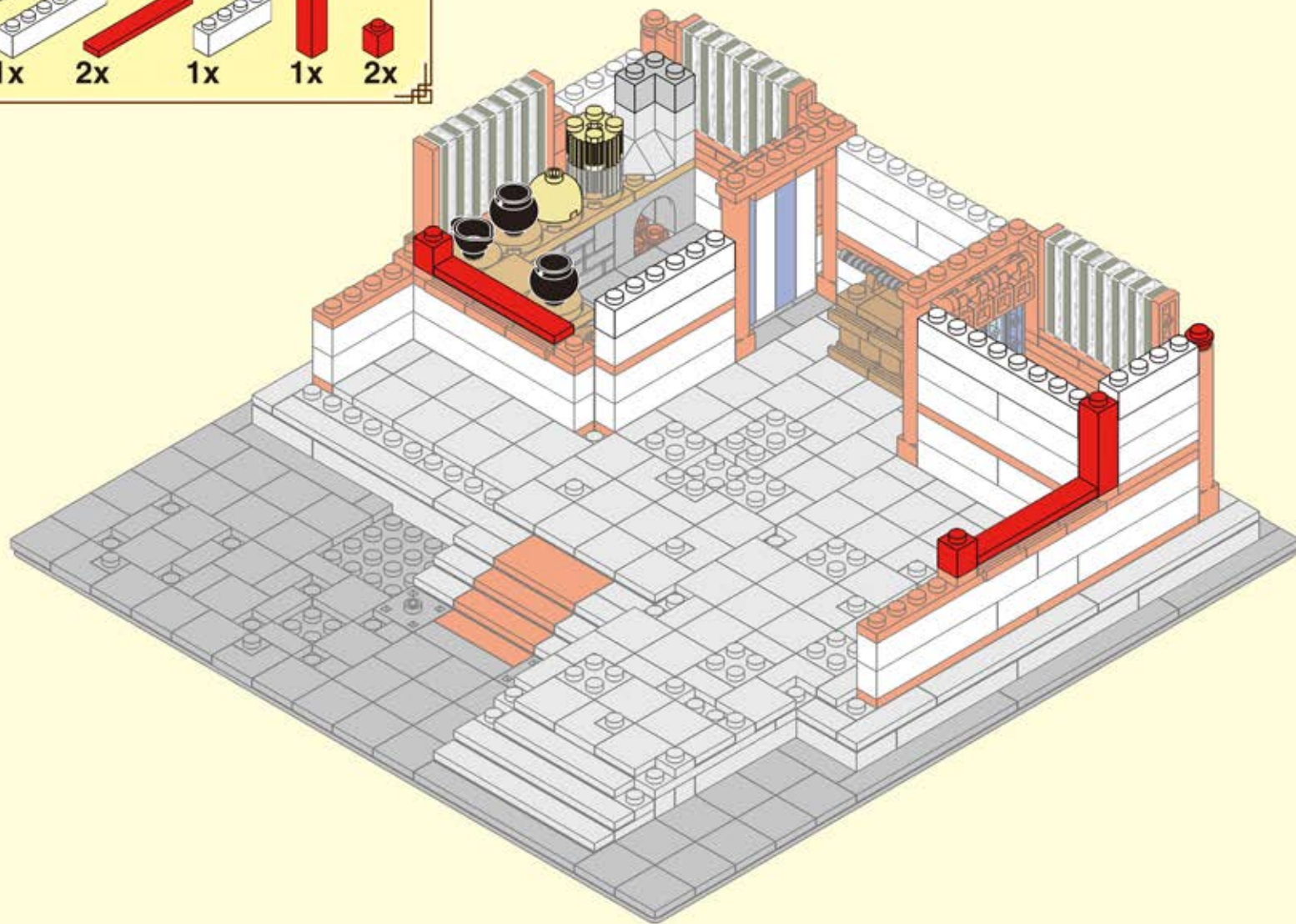

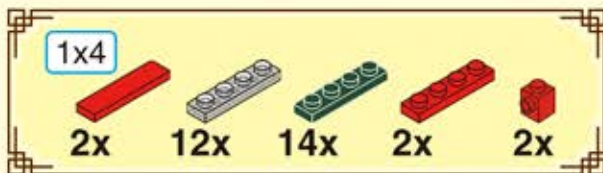

2-5

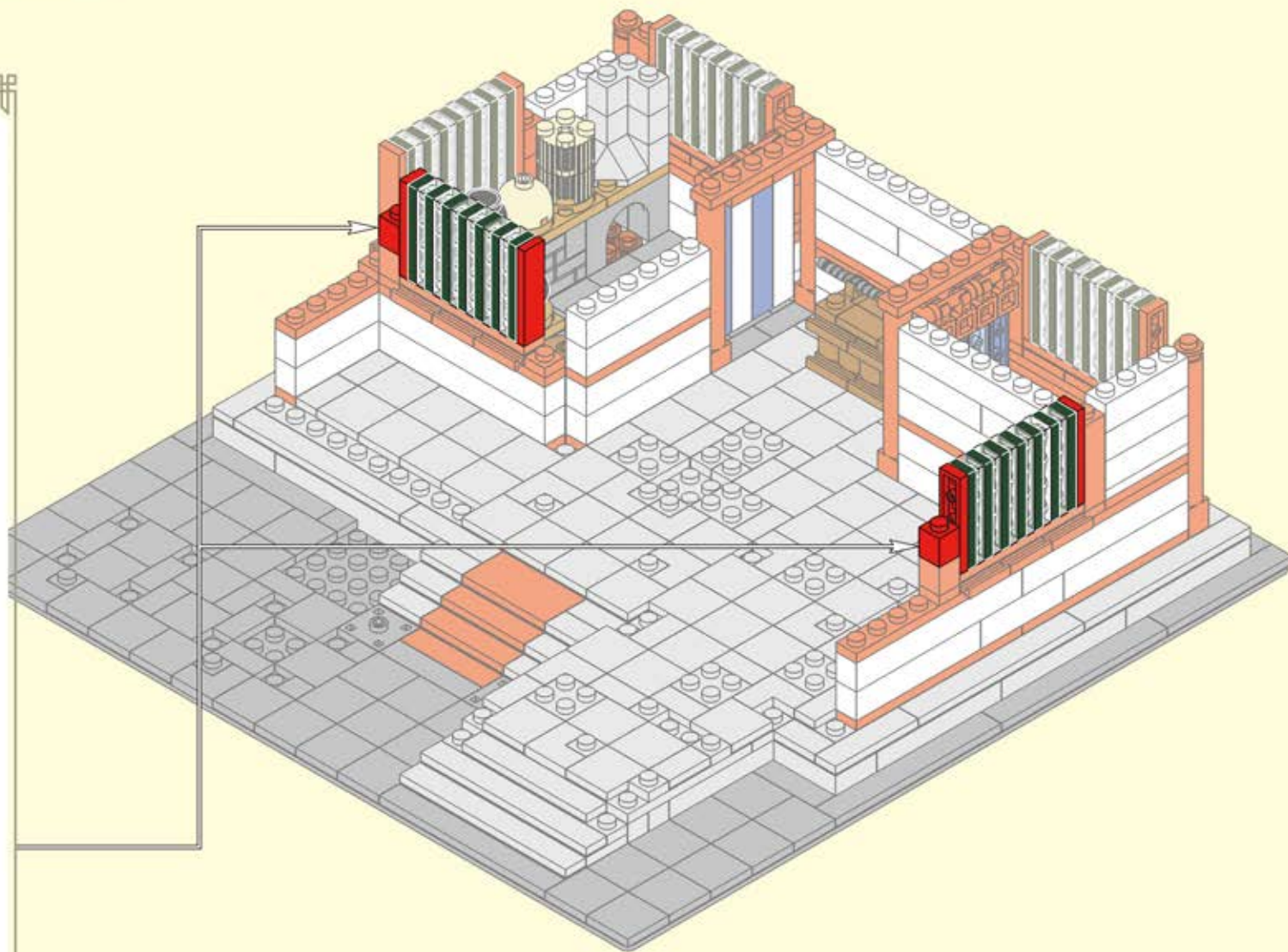
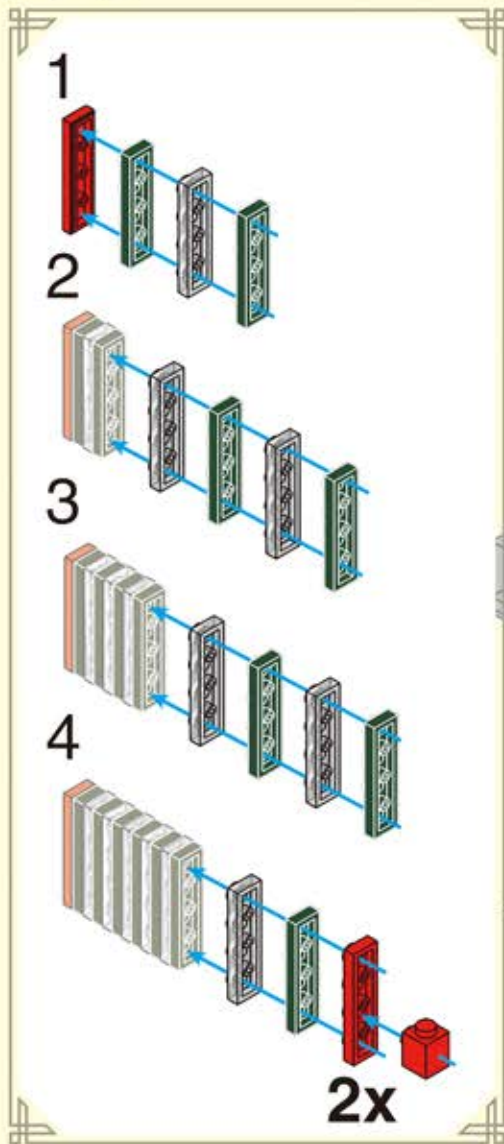

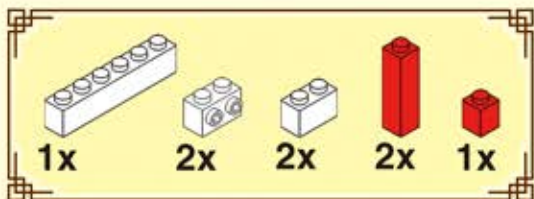

2-6

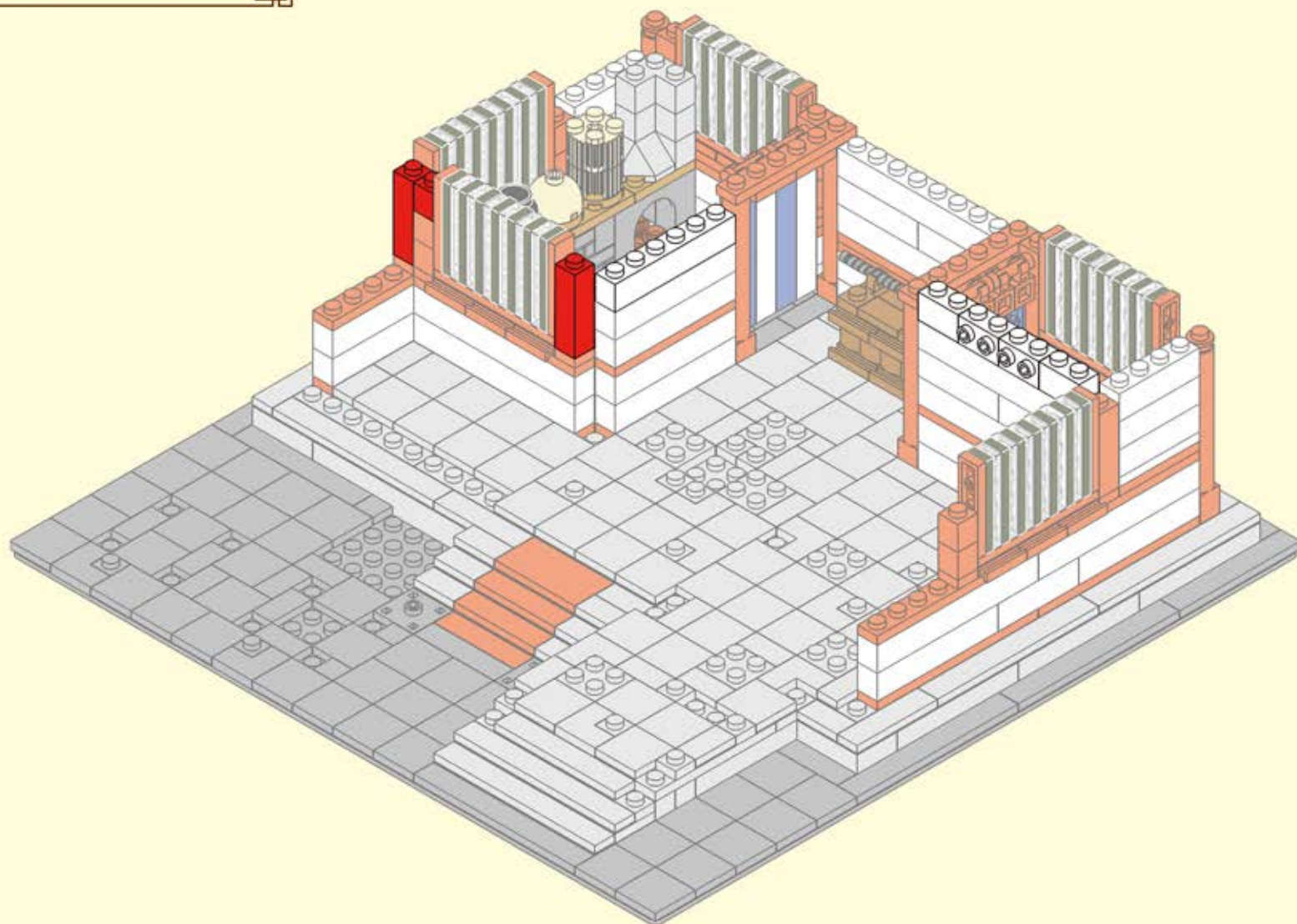

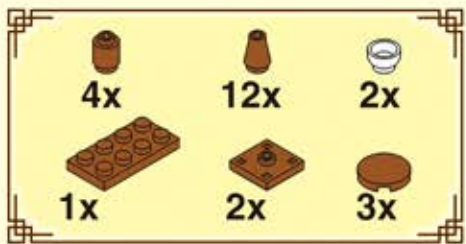

2-7

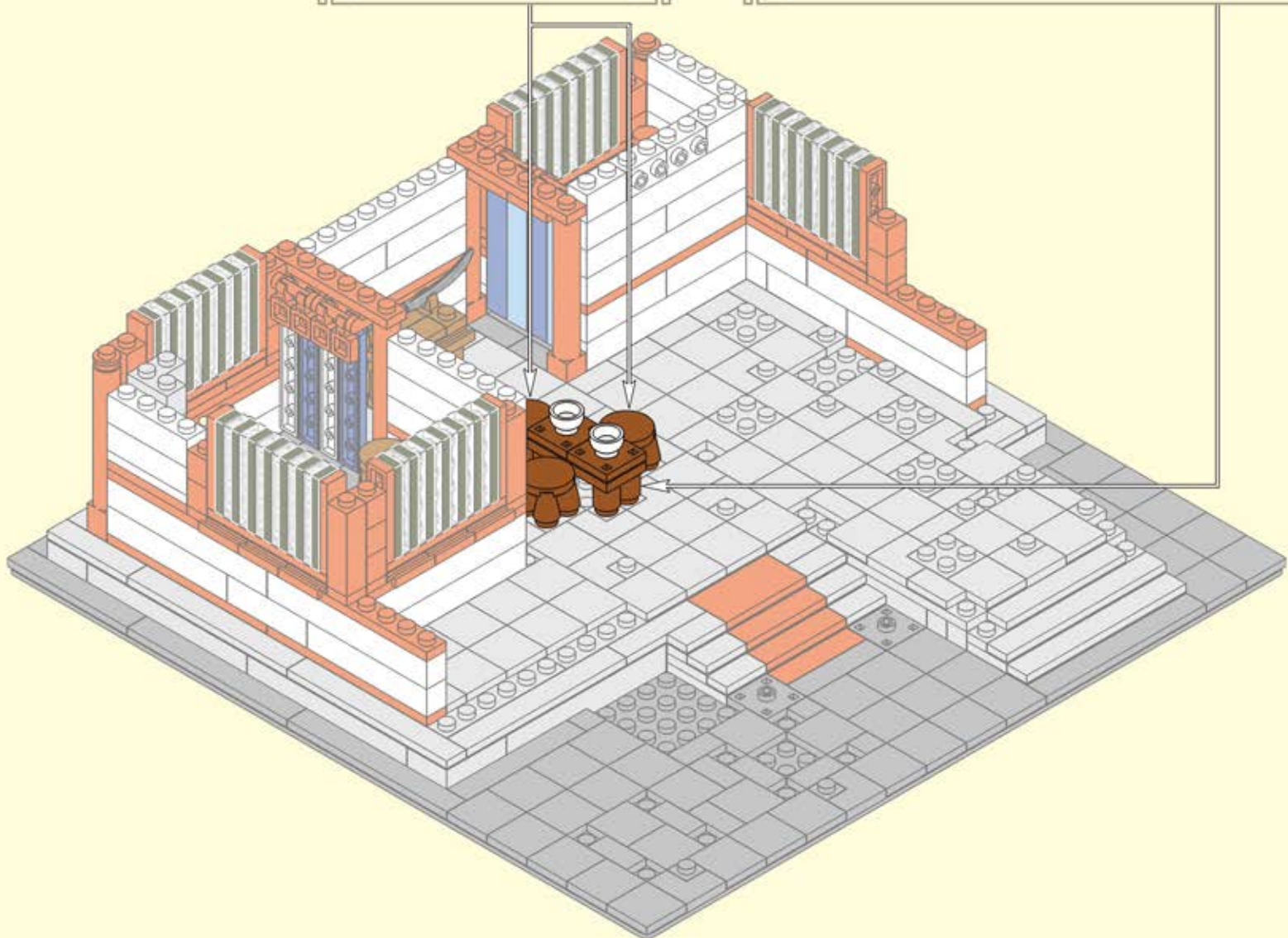
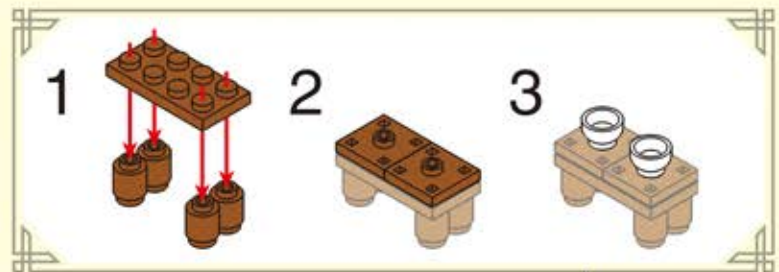
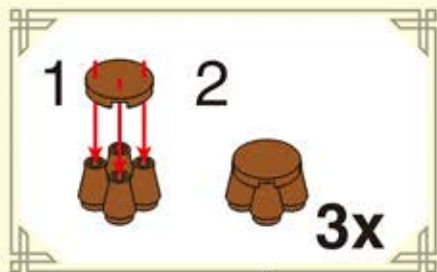

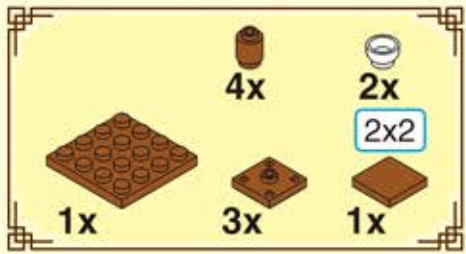

2-8

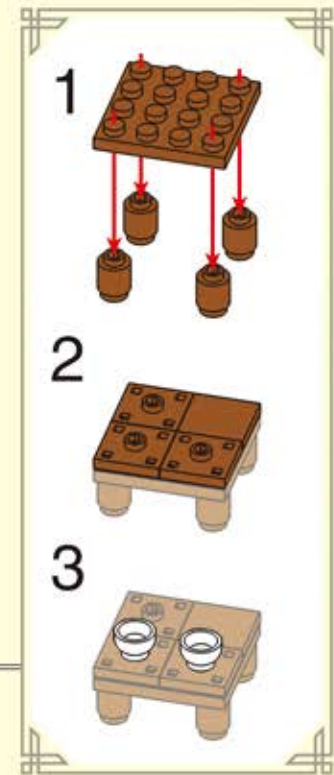
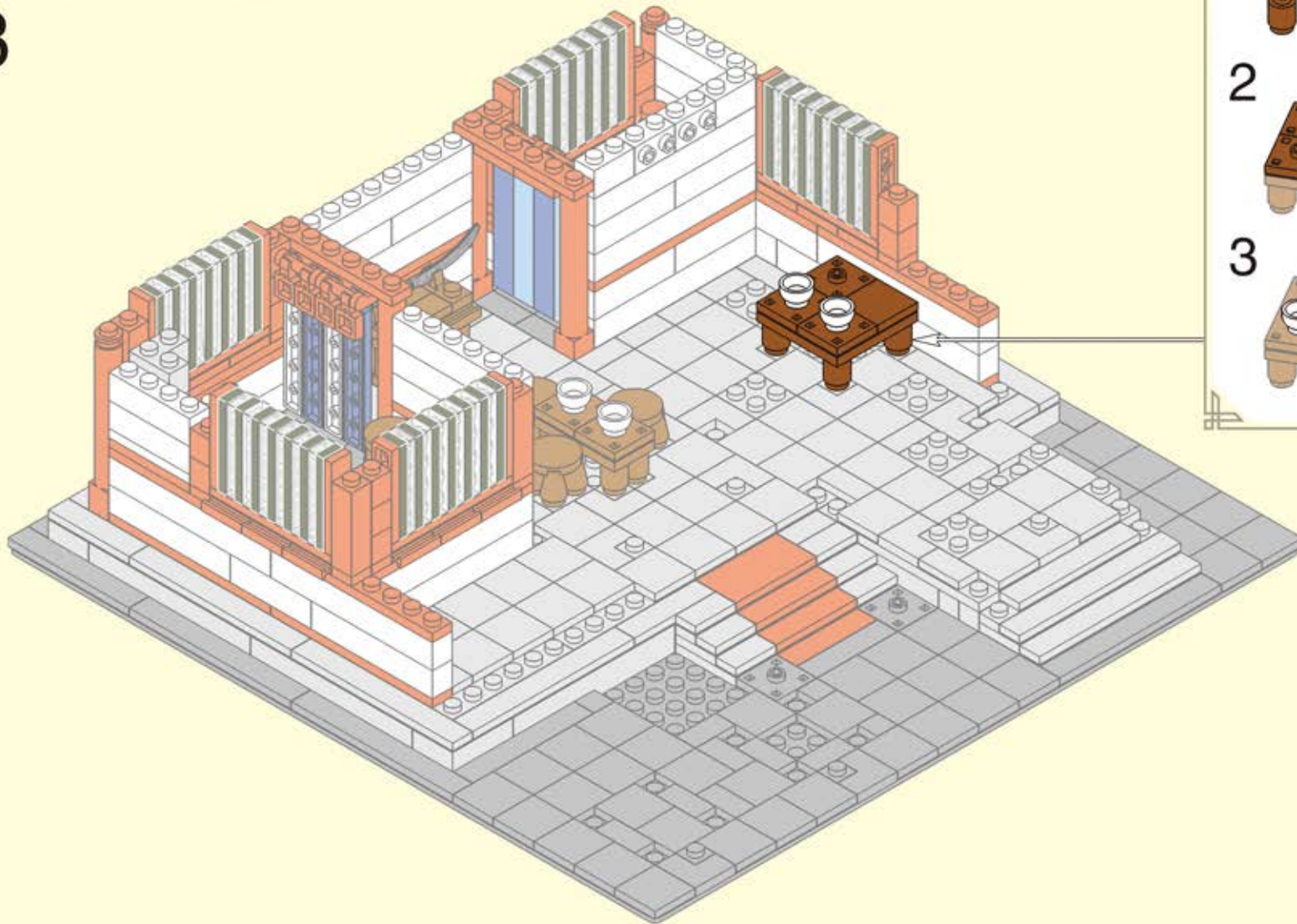

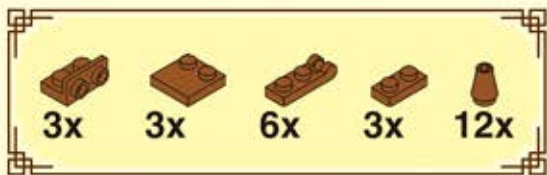

2-9

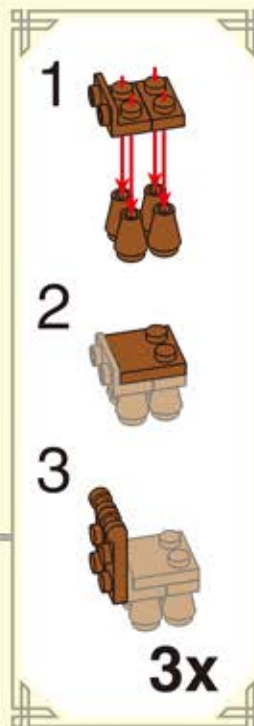
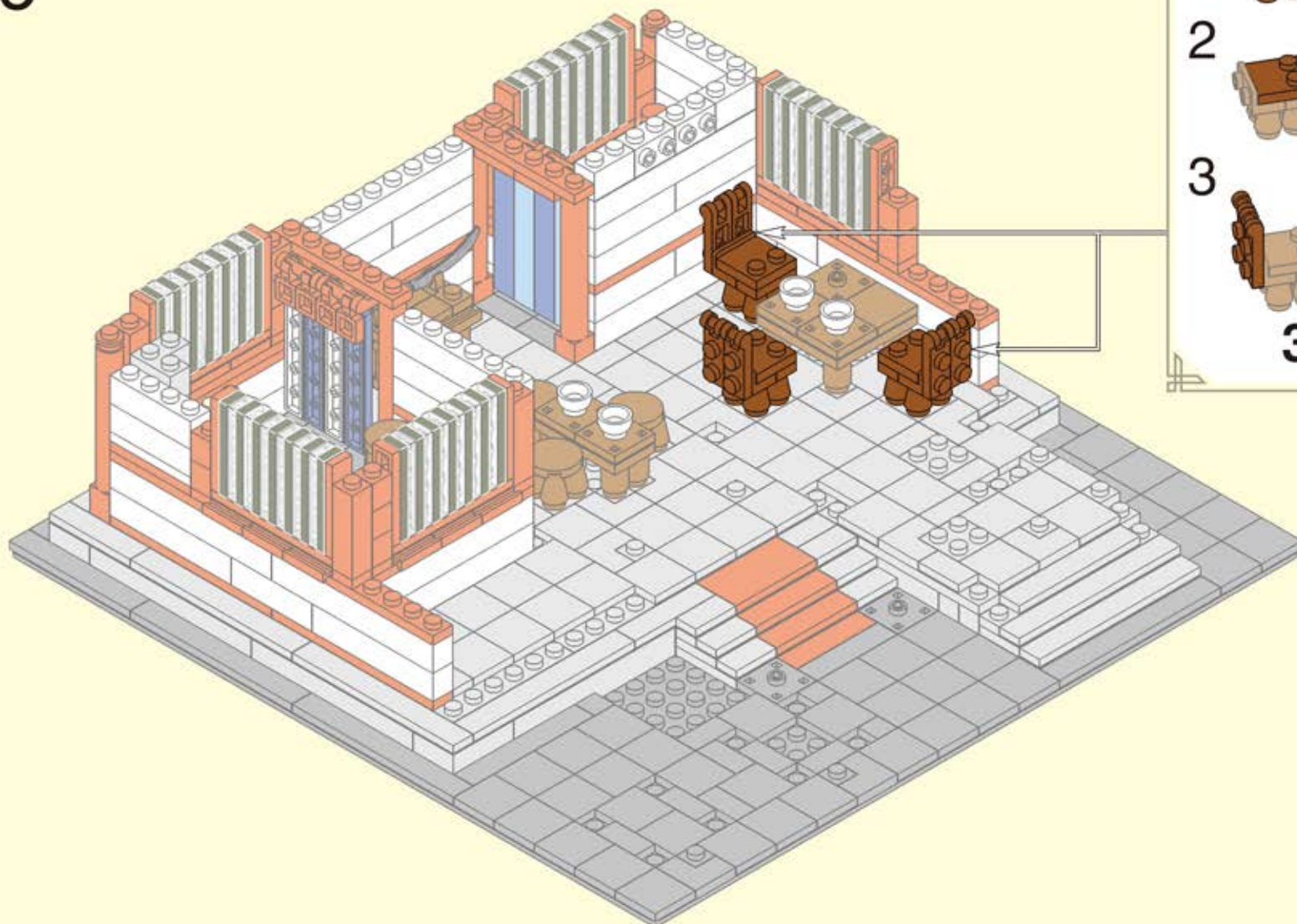

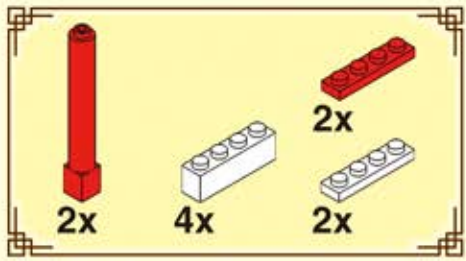

2-10

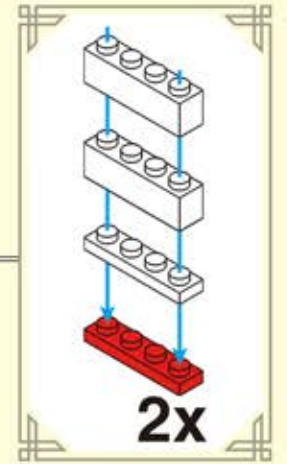
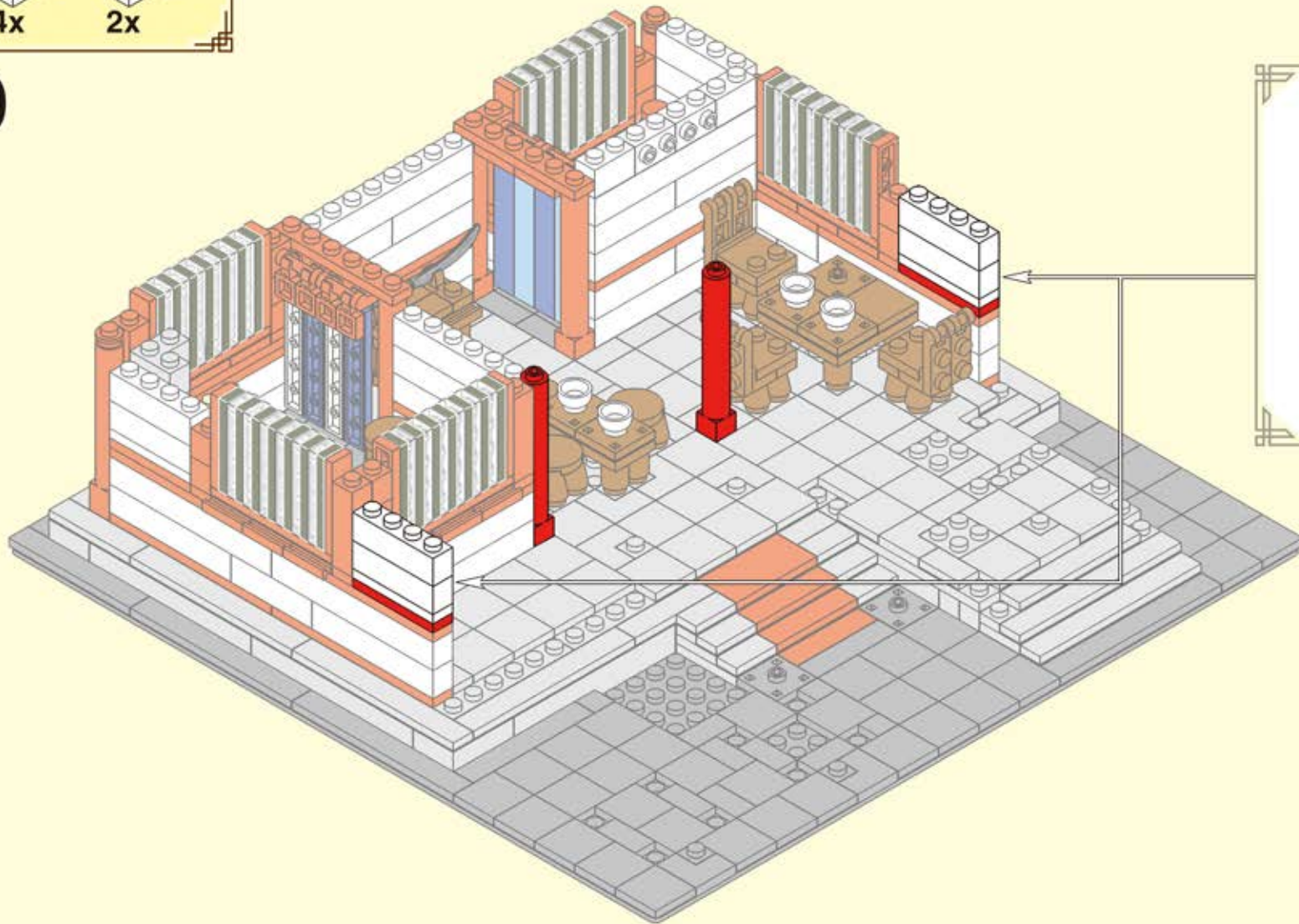

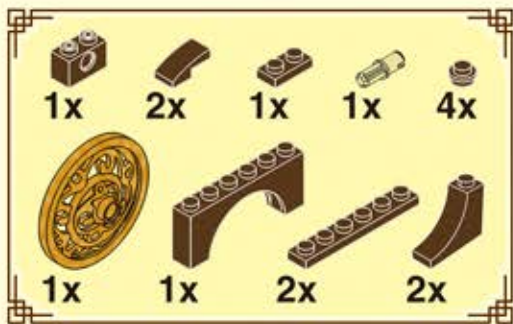

2-11

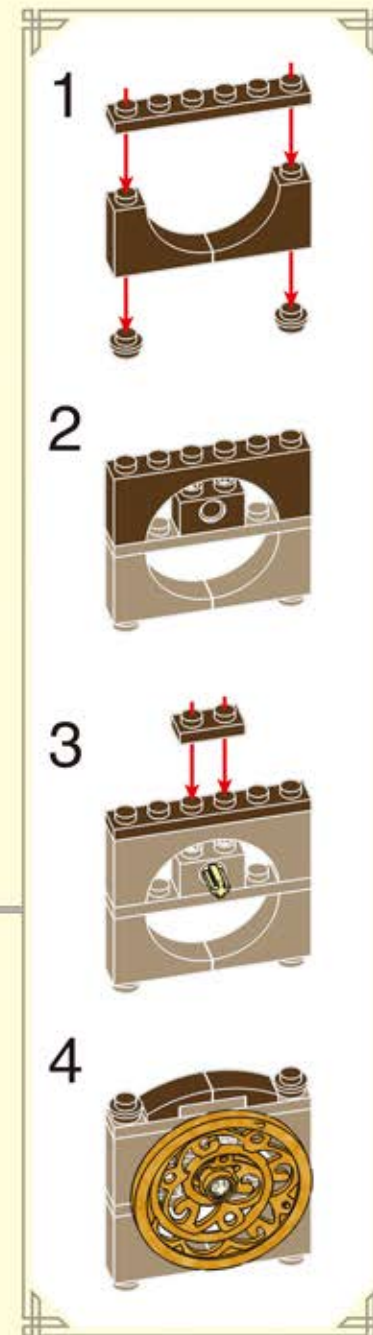
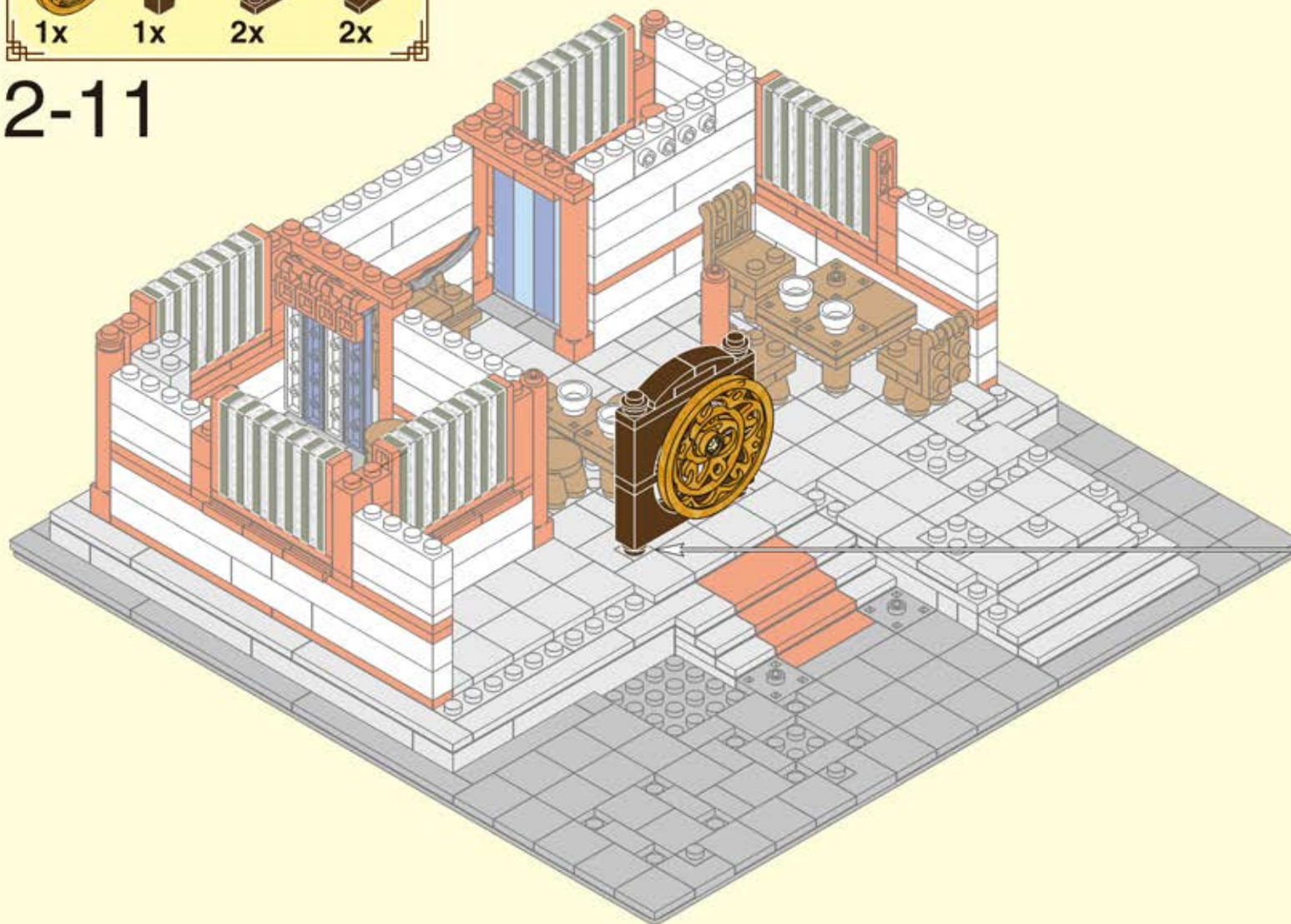

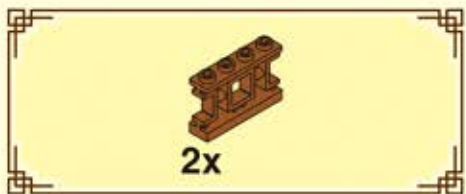

2-12

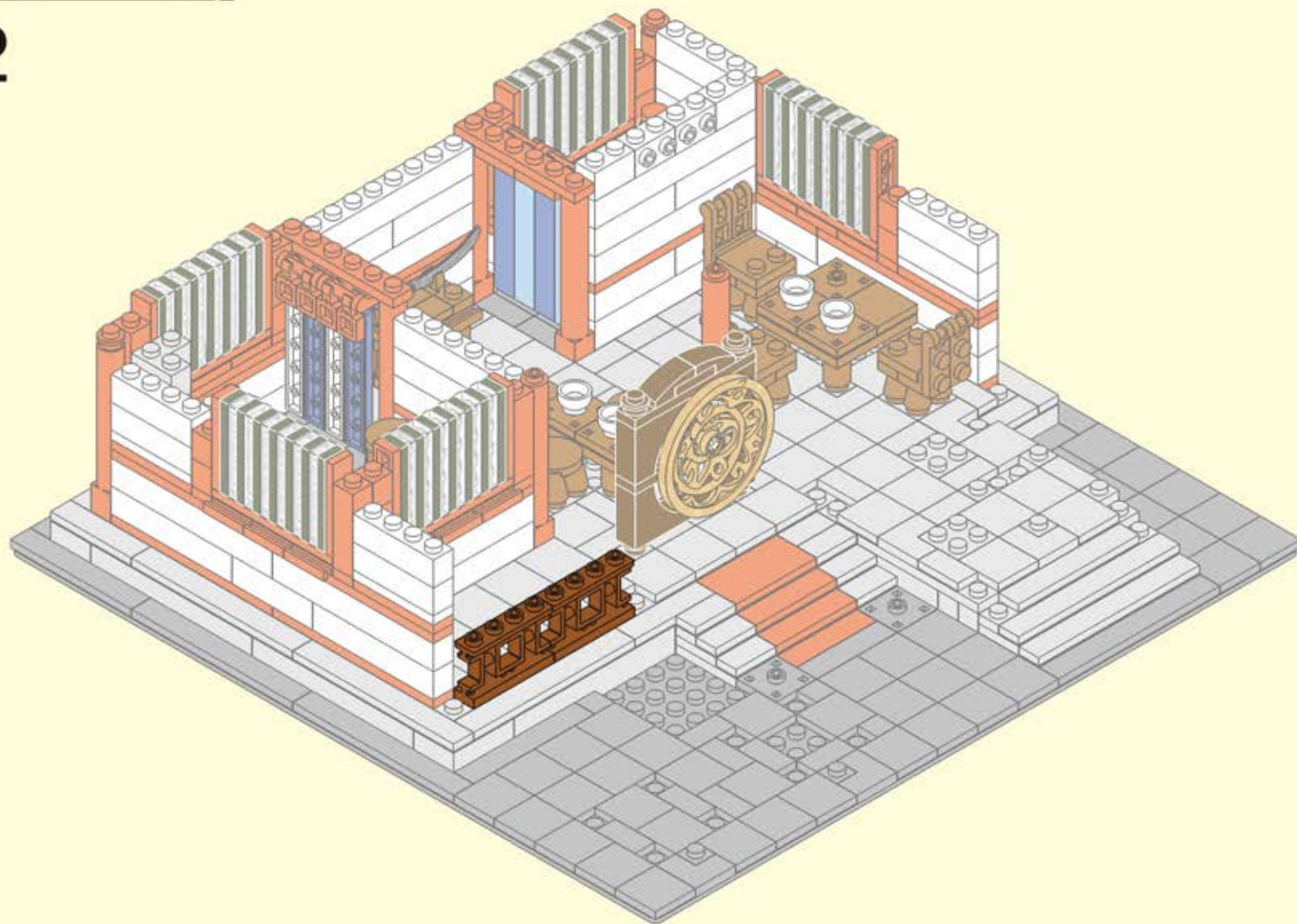

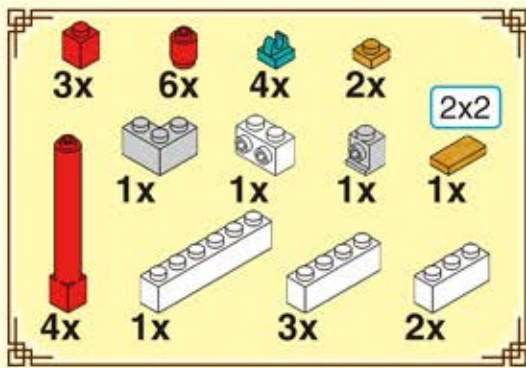

2-13

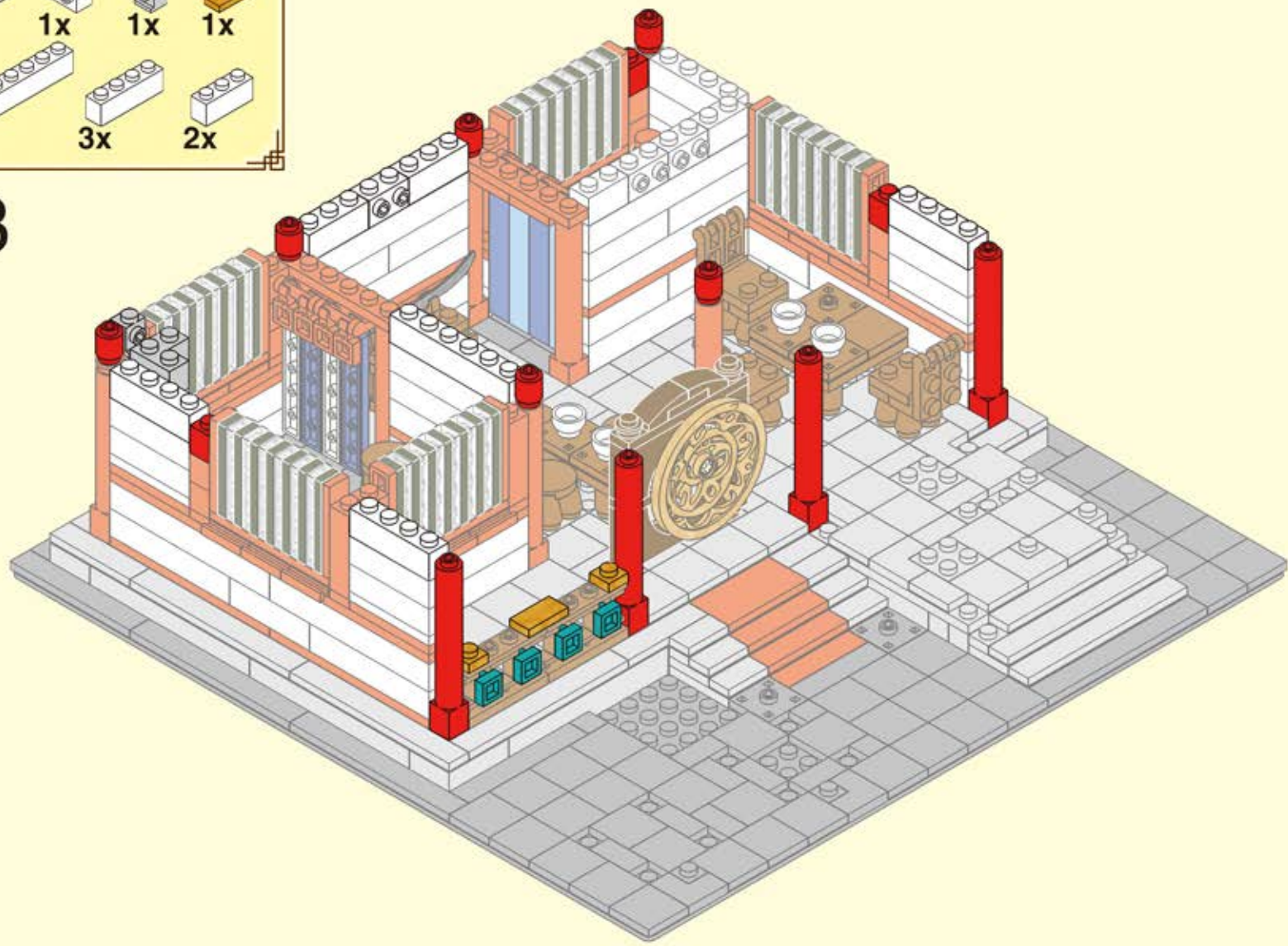

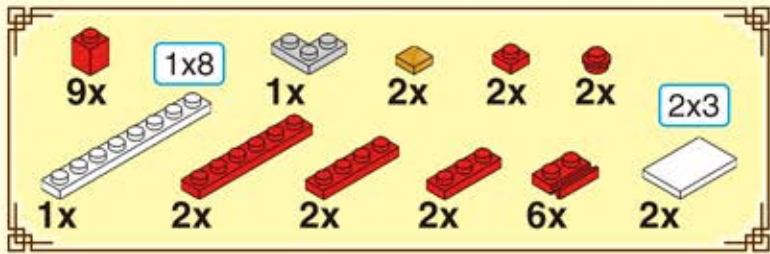

# 2-14

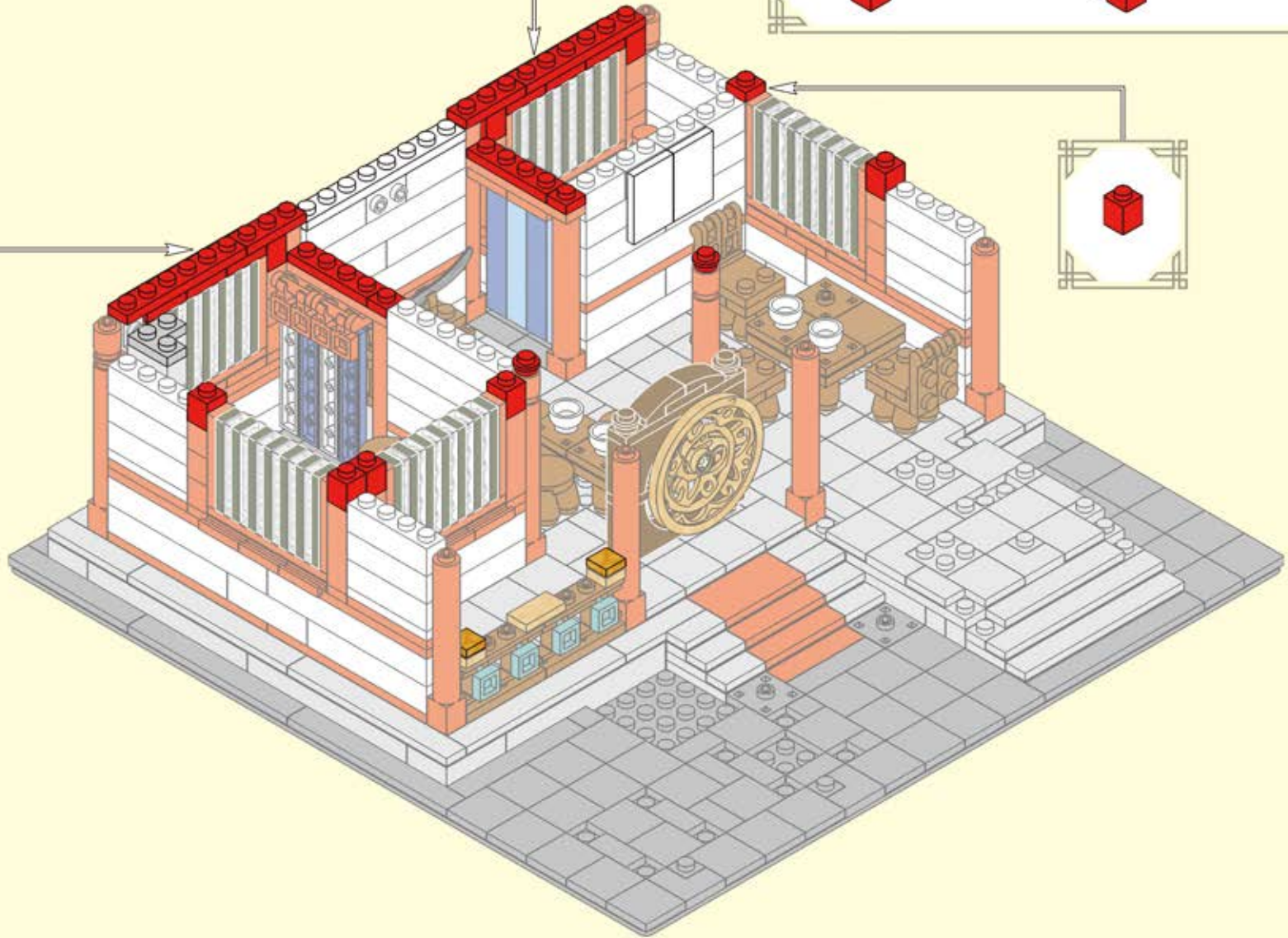
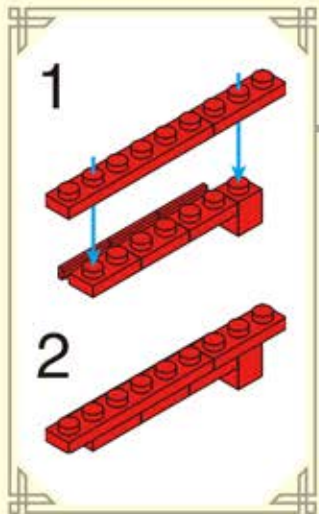
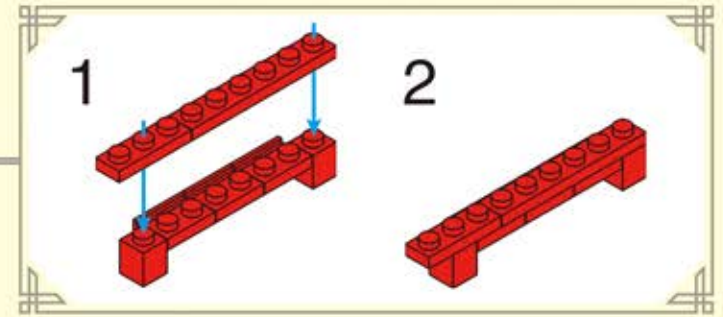

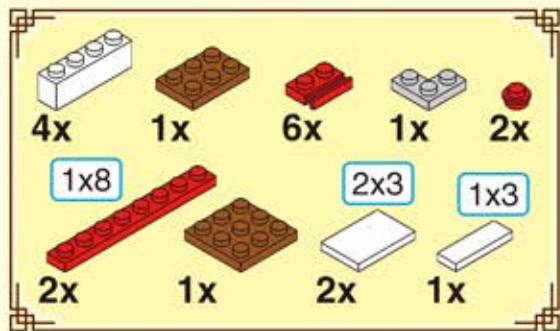

2-15

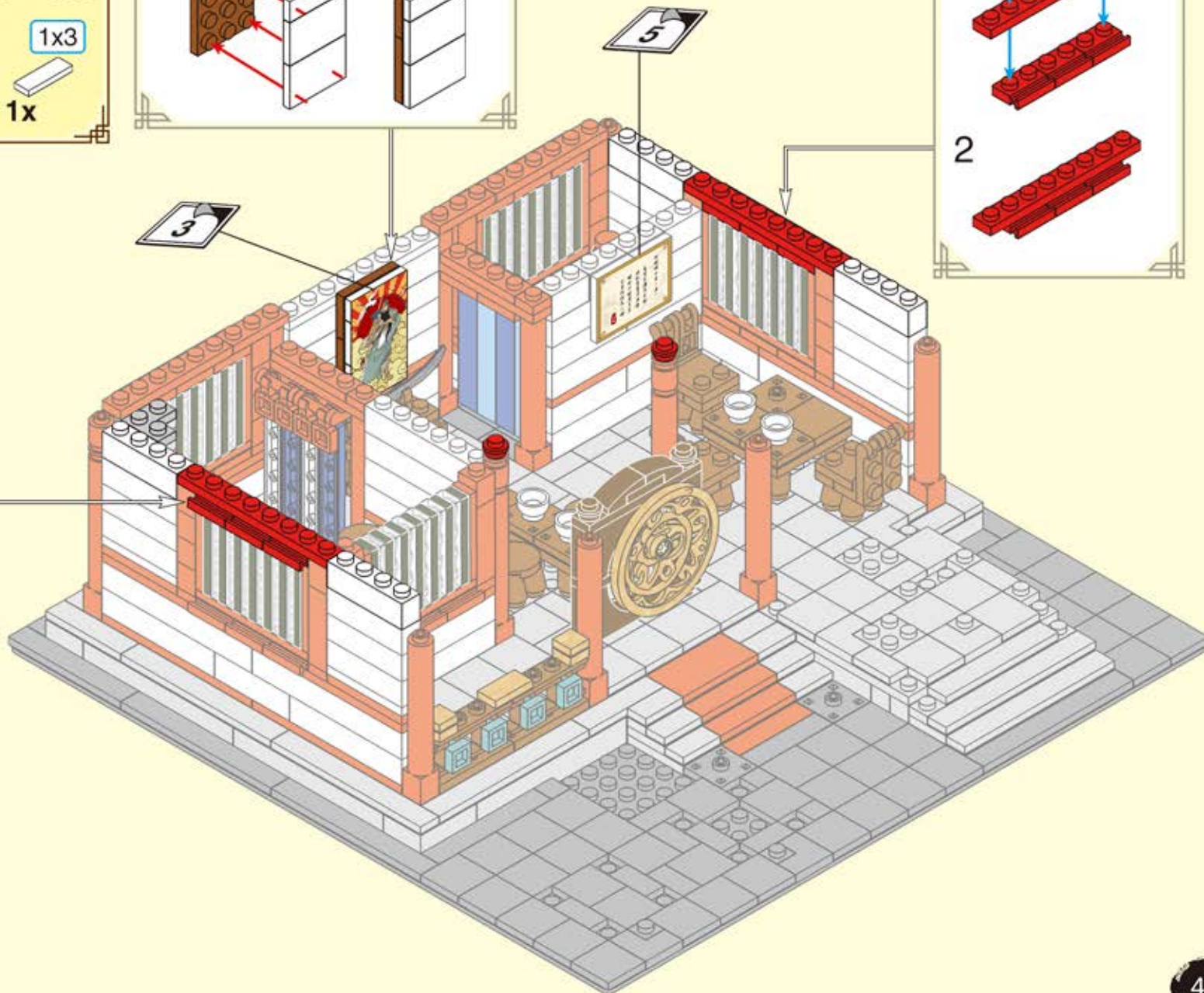
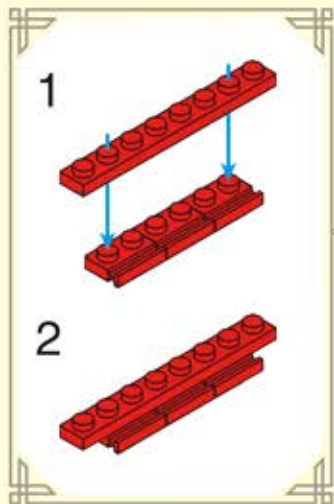
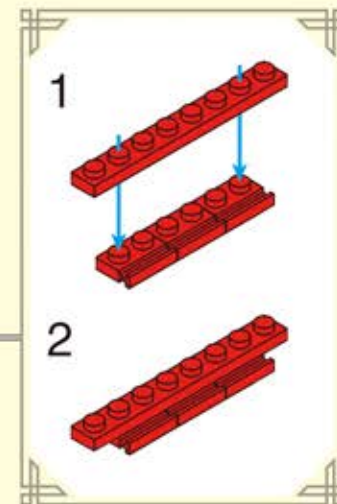
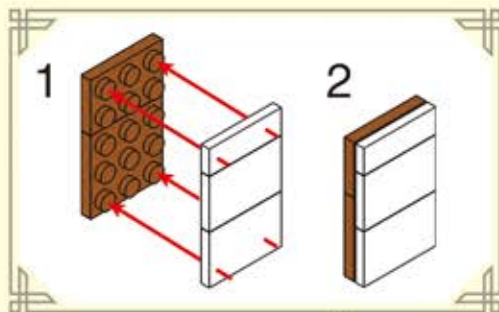

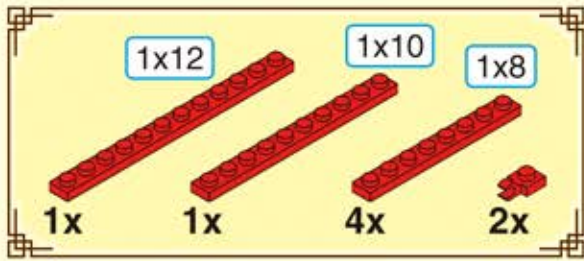

# 2-16

1

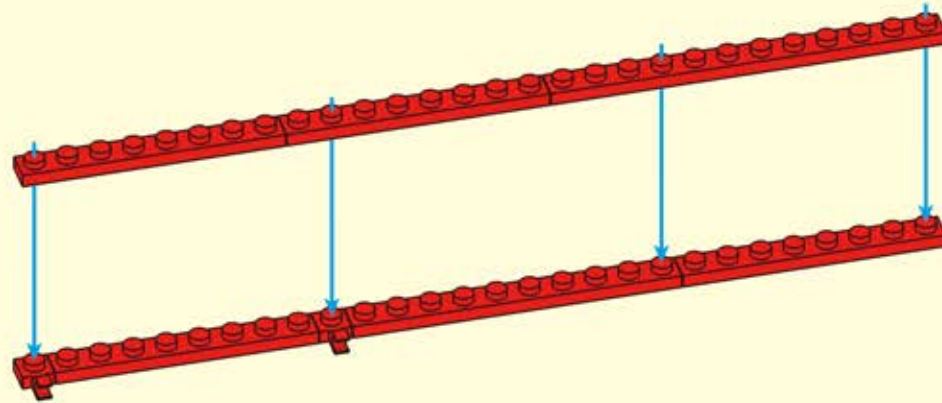

2

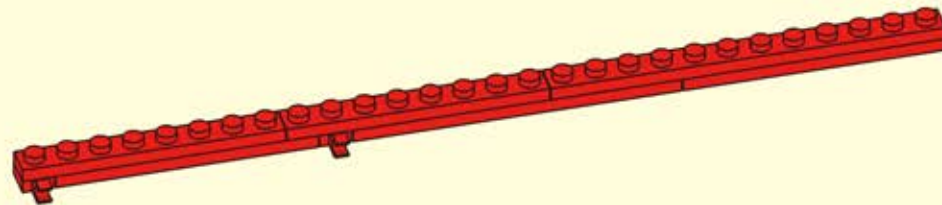

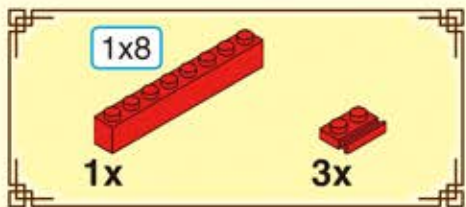

2-17

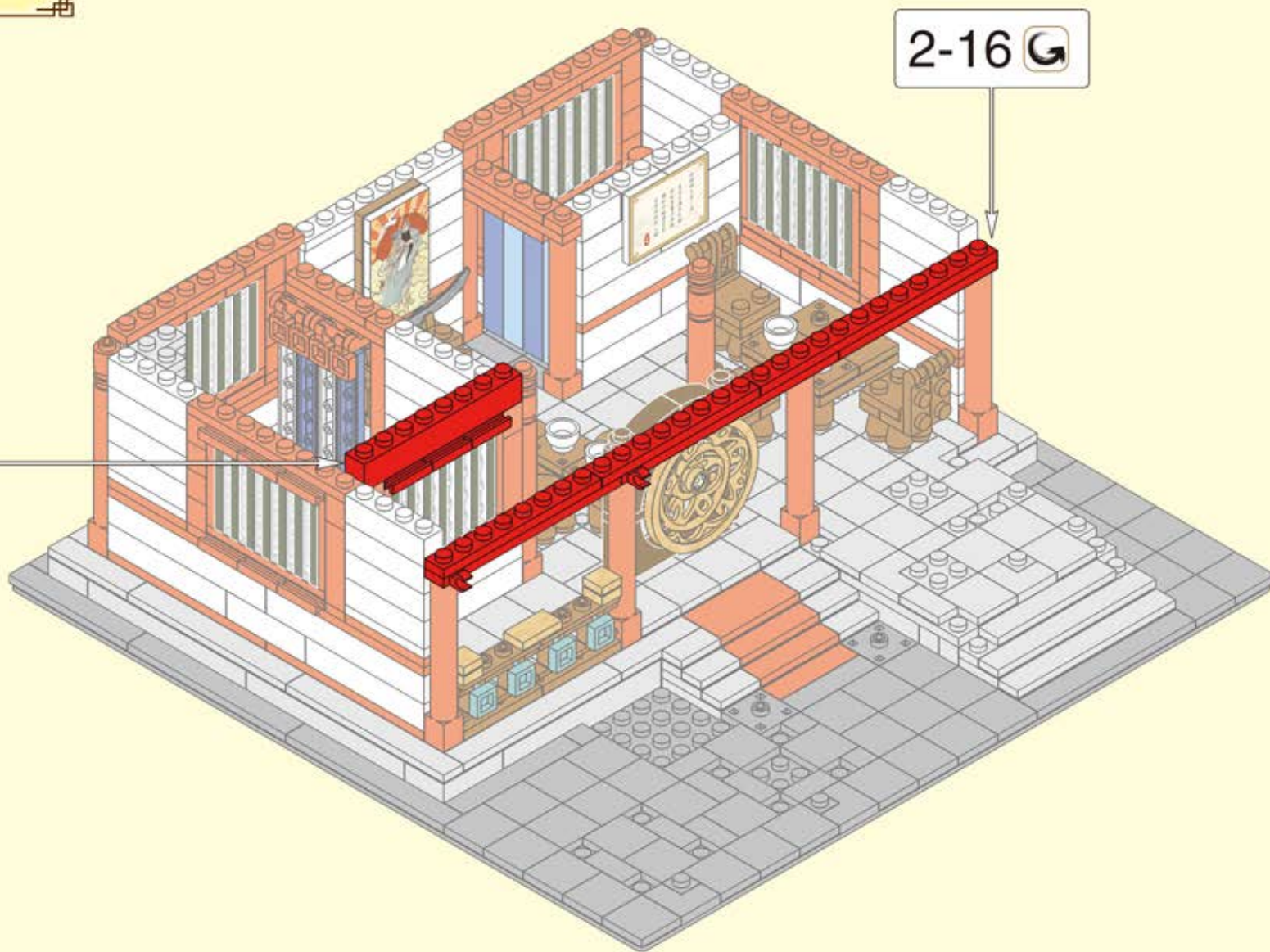
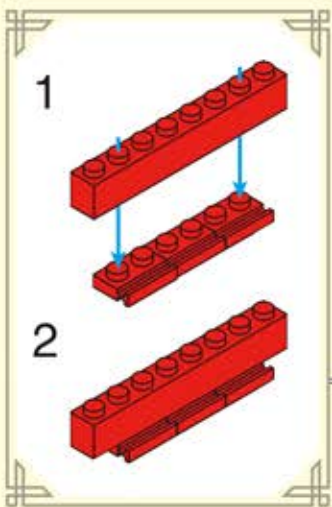

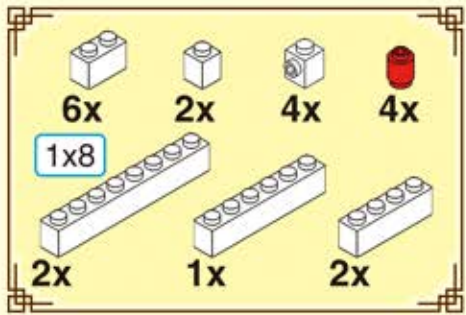

2-18



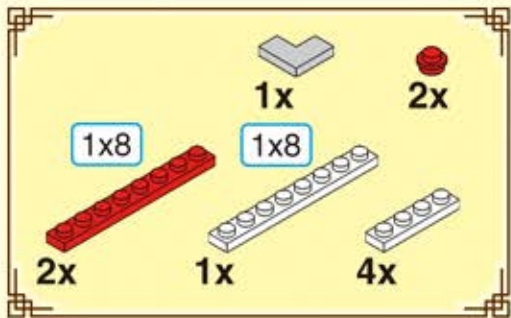

2-19



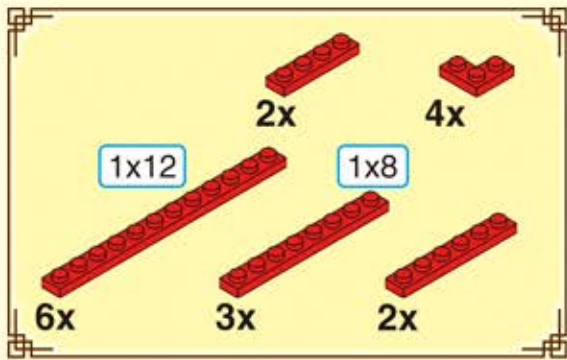

2-20

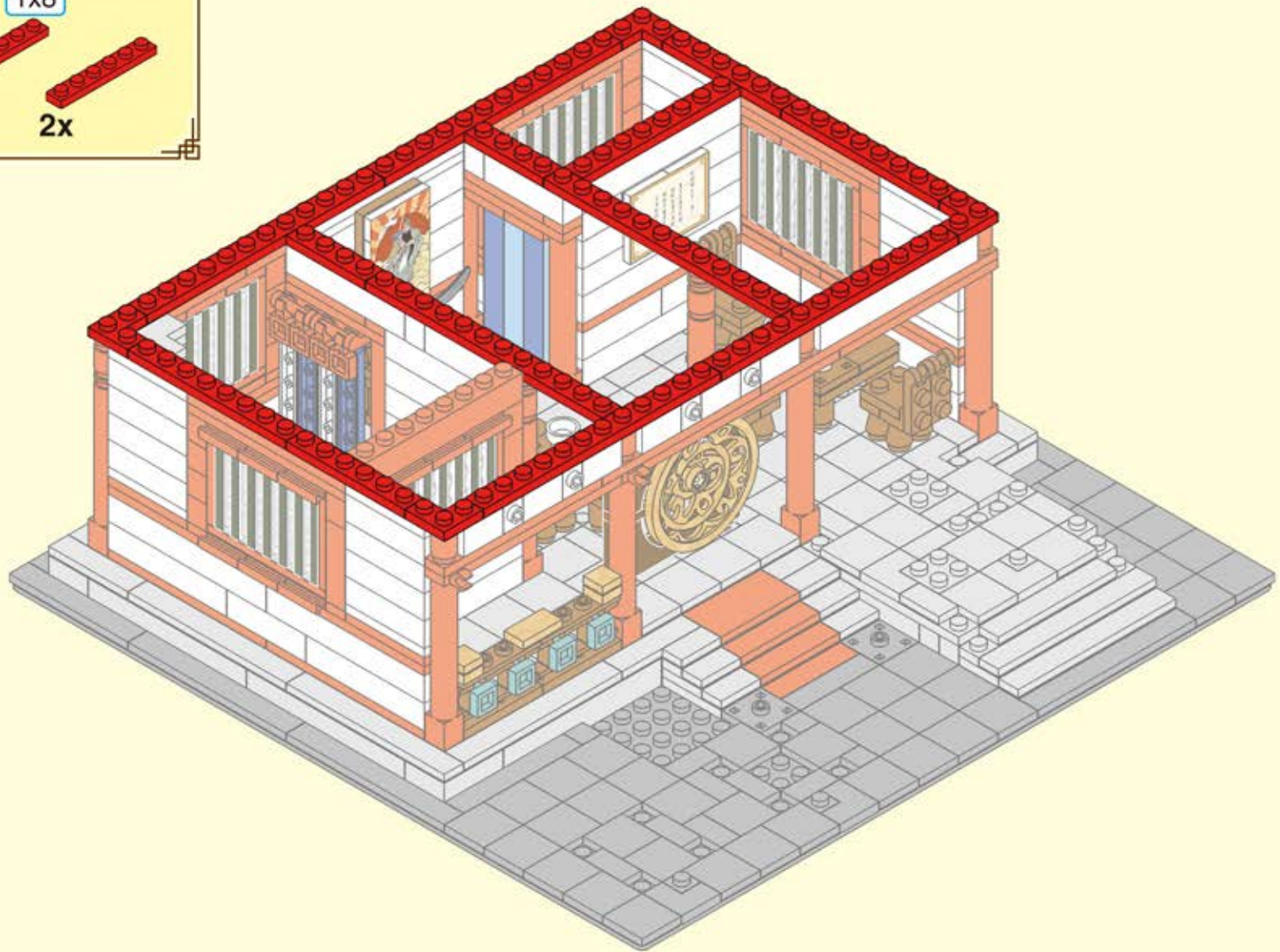

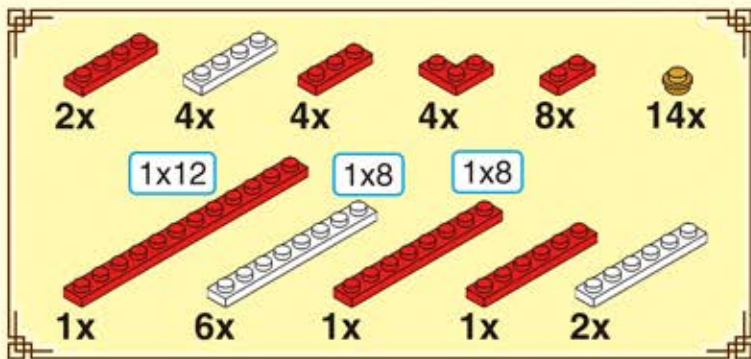

2-21

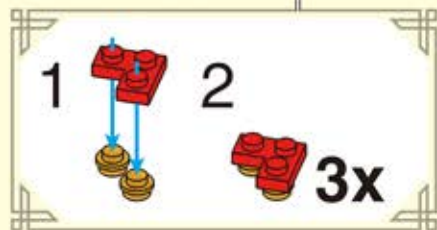
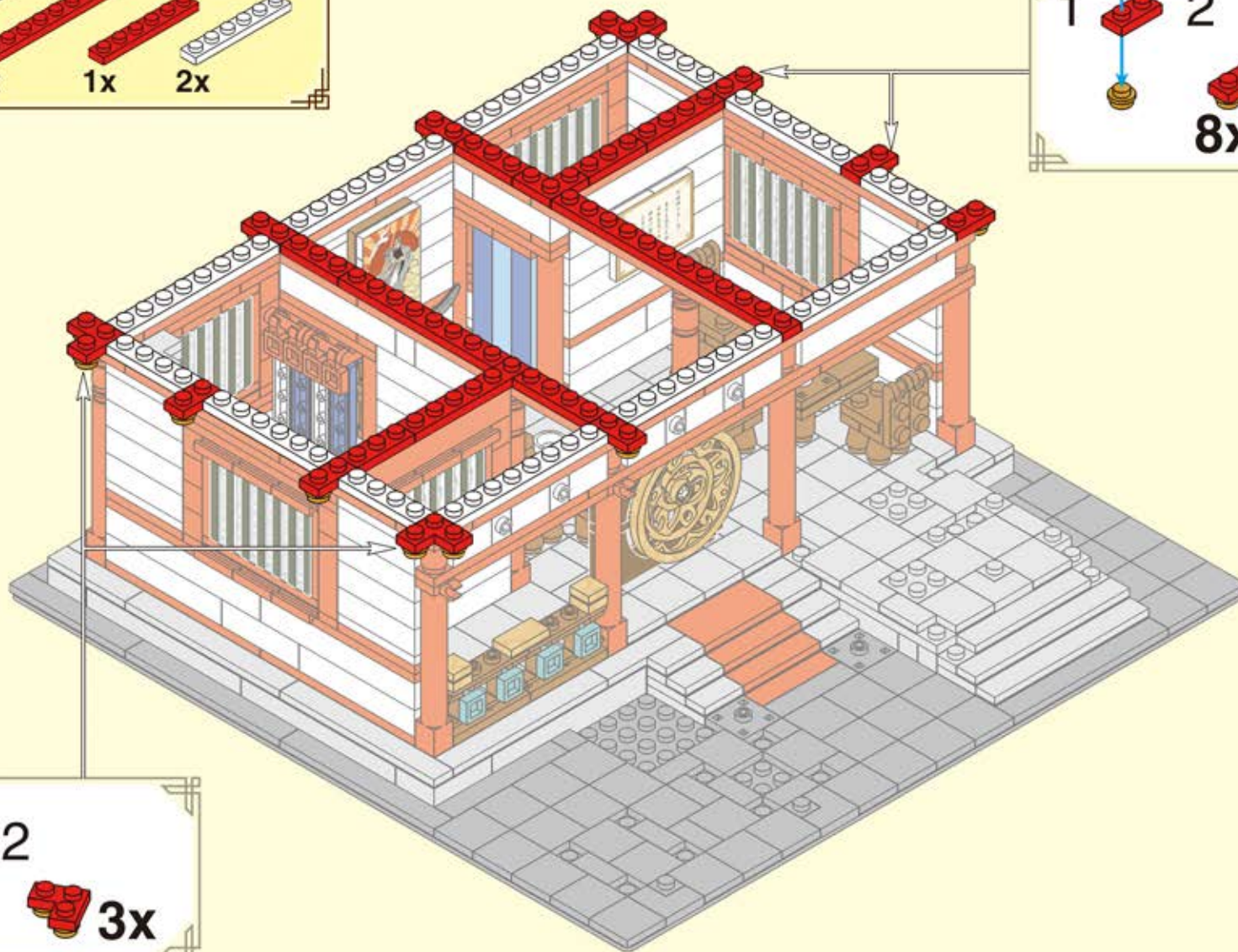
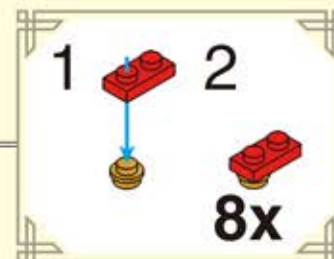

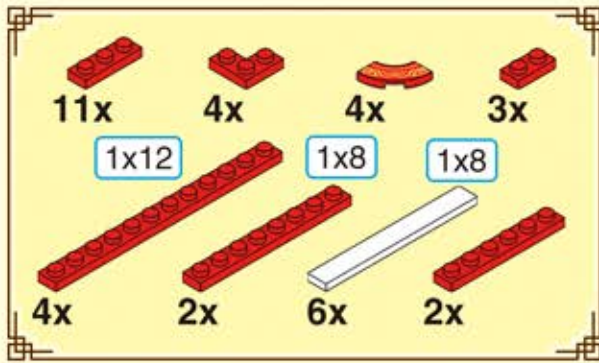

2-22

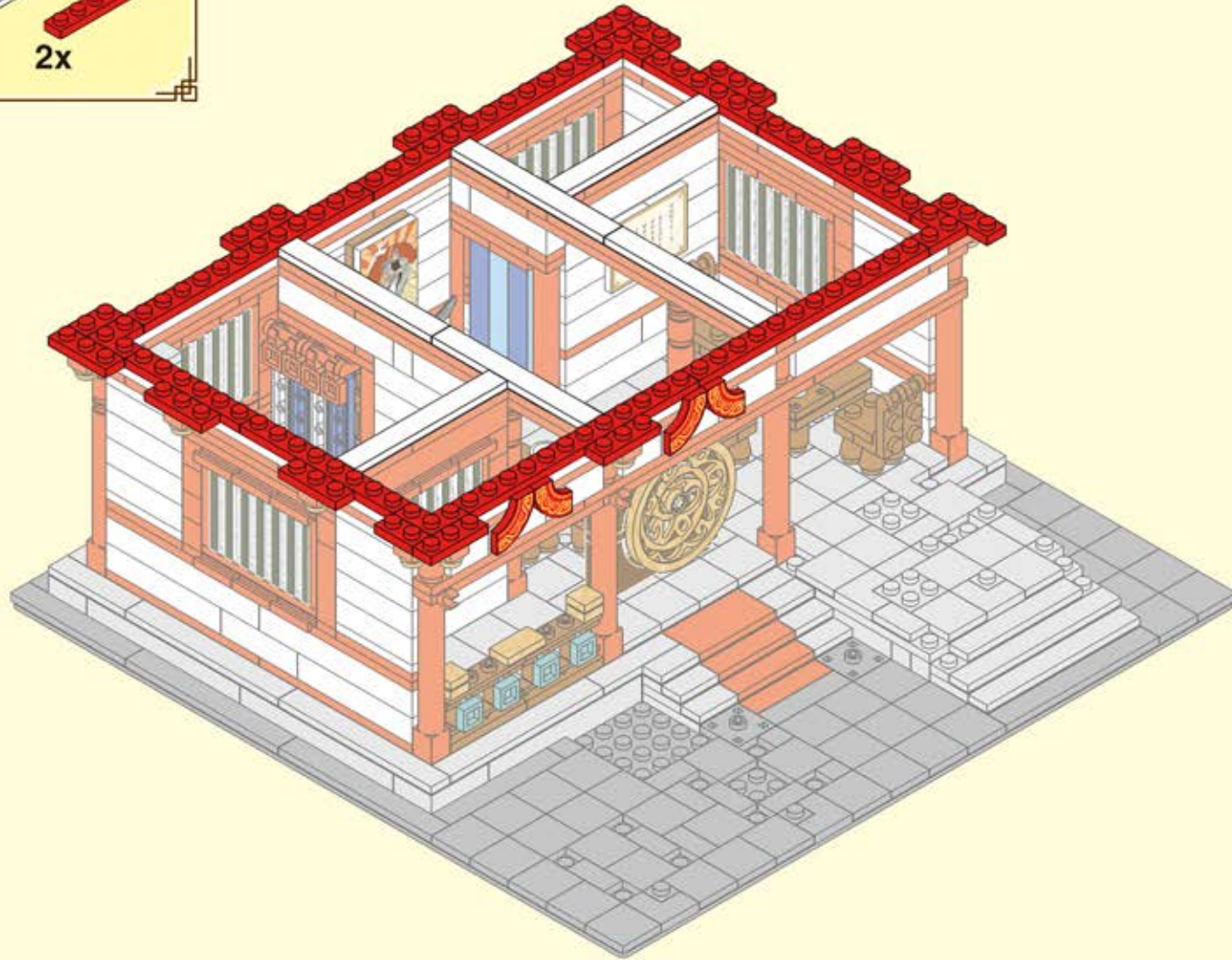

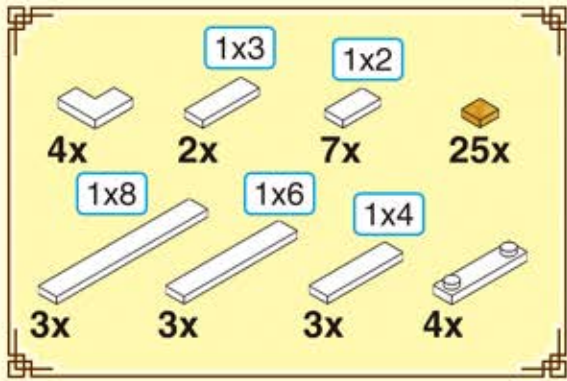

2-23





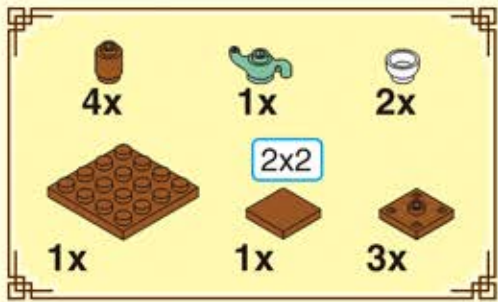

3-1

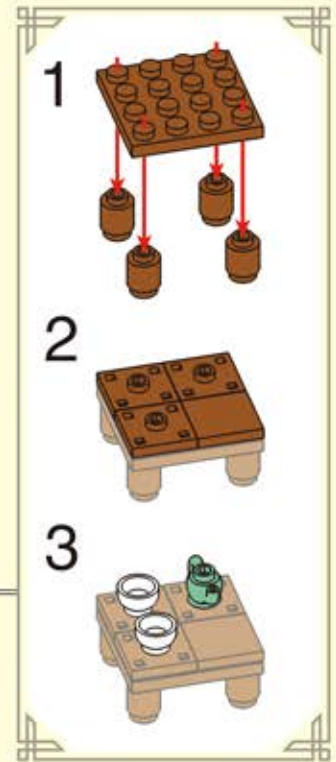



3-2

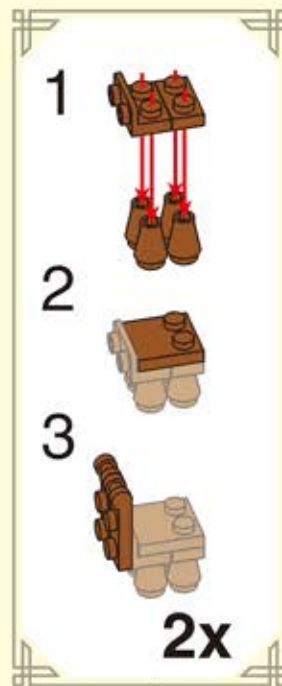



3-3

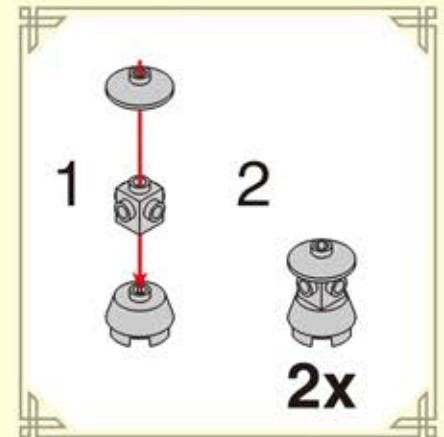

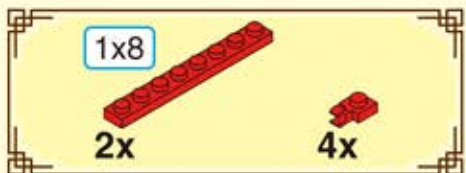

3-4

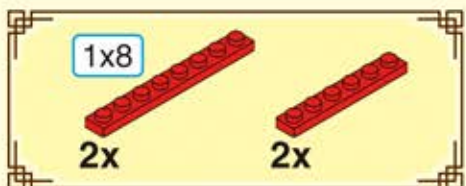
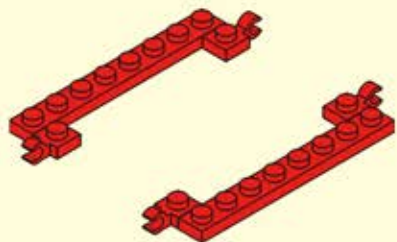

3-5

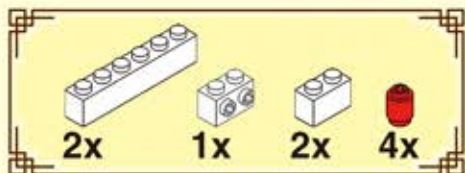
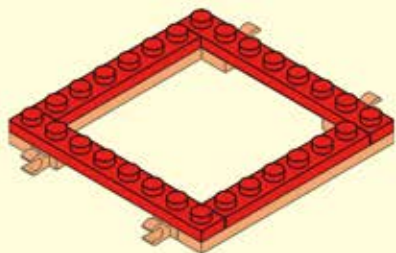

3-6

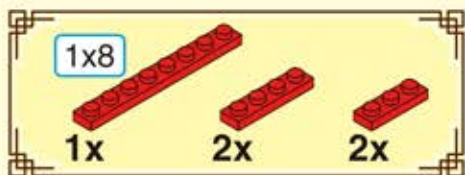
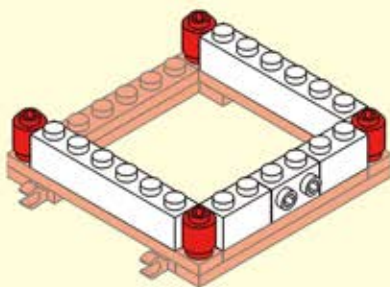

3-7

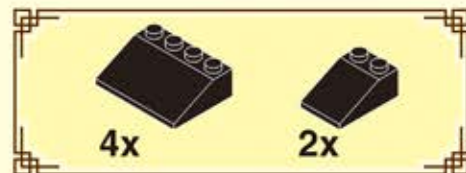
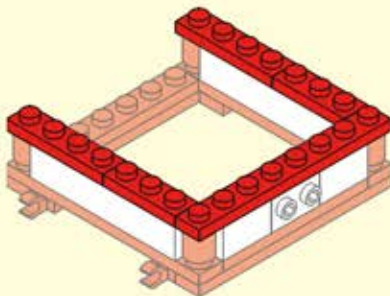

3-8

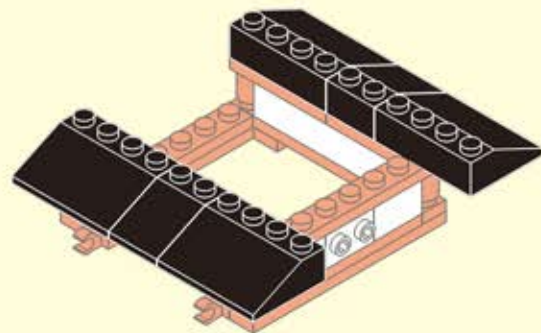

3-9

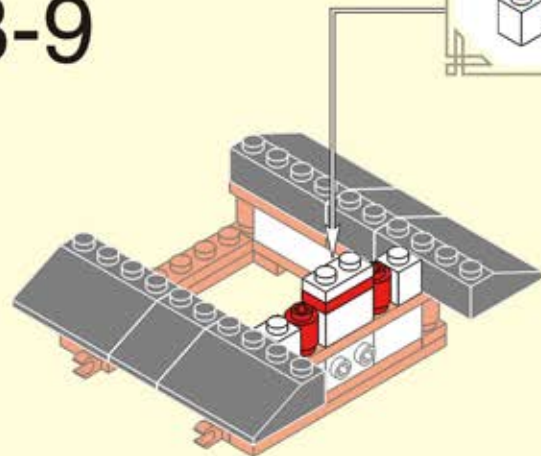

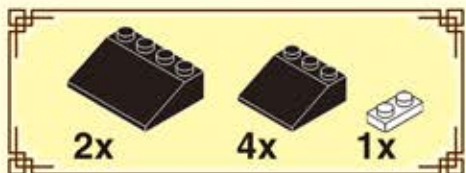

3-10

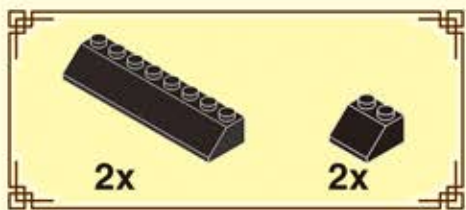
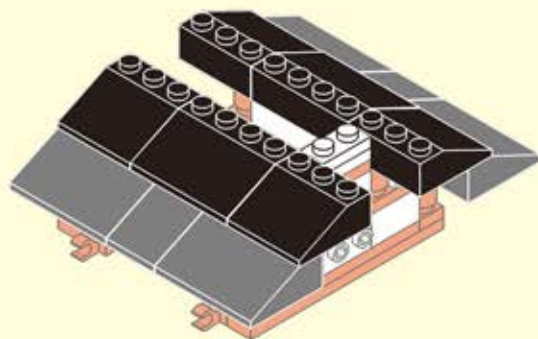

3-11

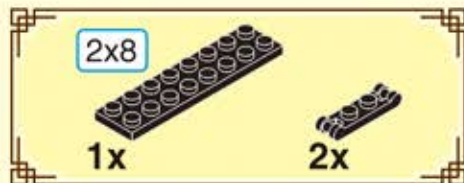
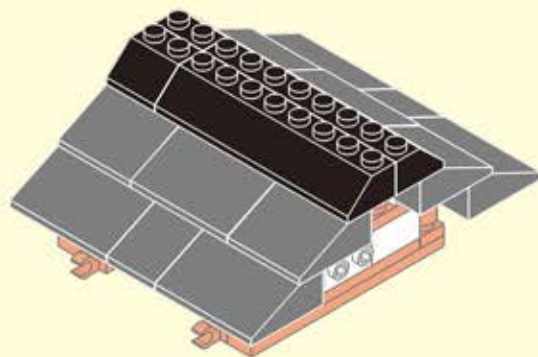

3-12

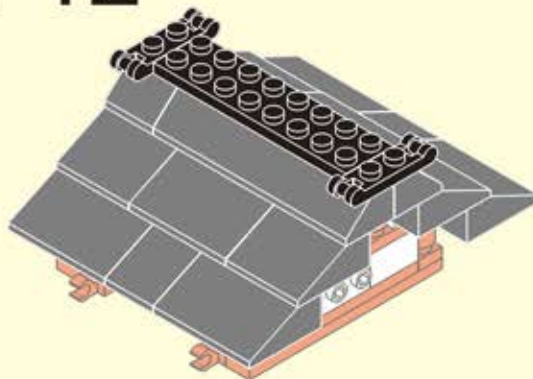

3-13

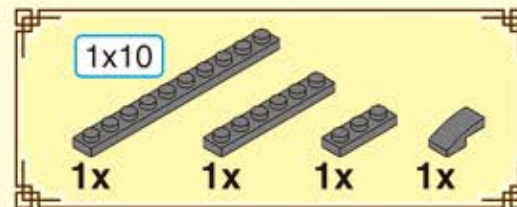
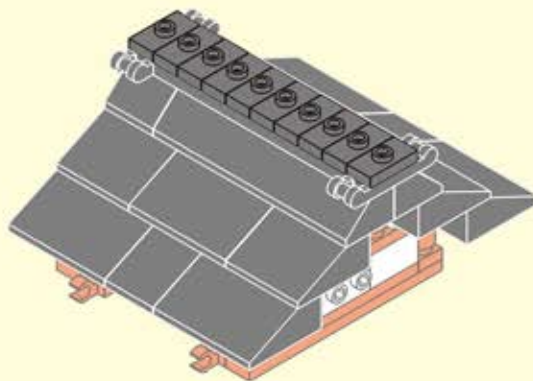

3-14

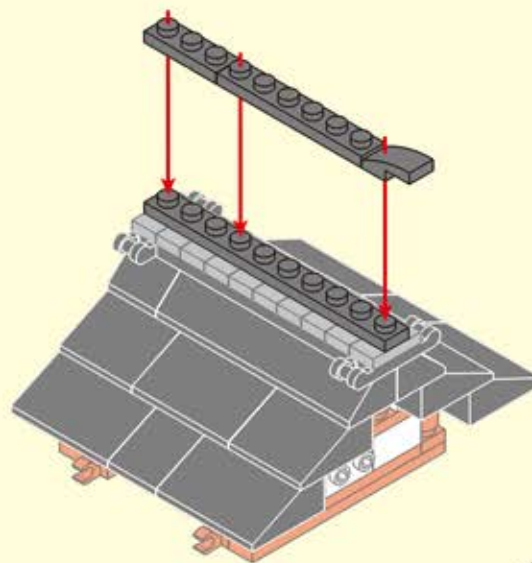



3-15

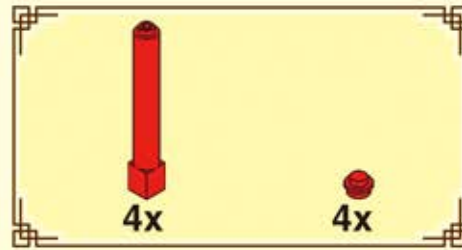
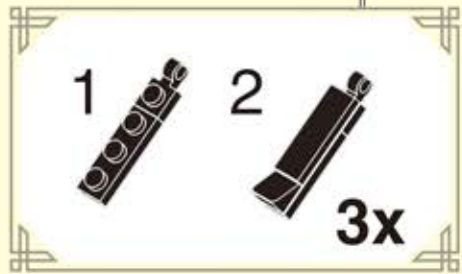
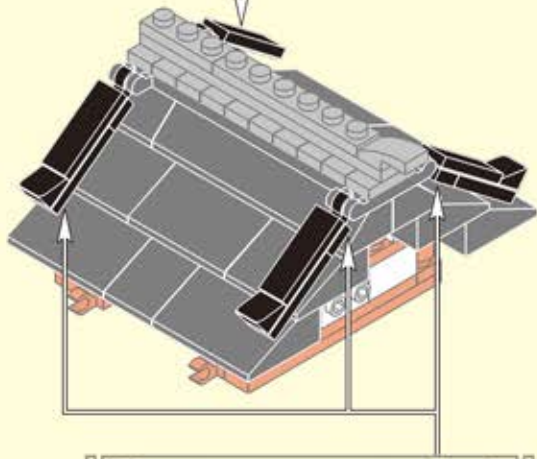

3-16

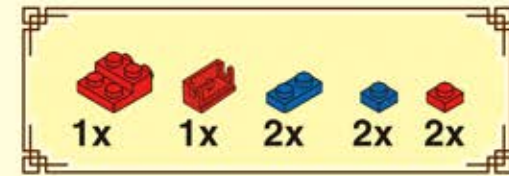
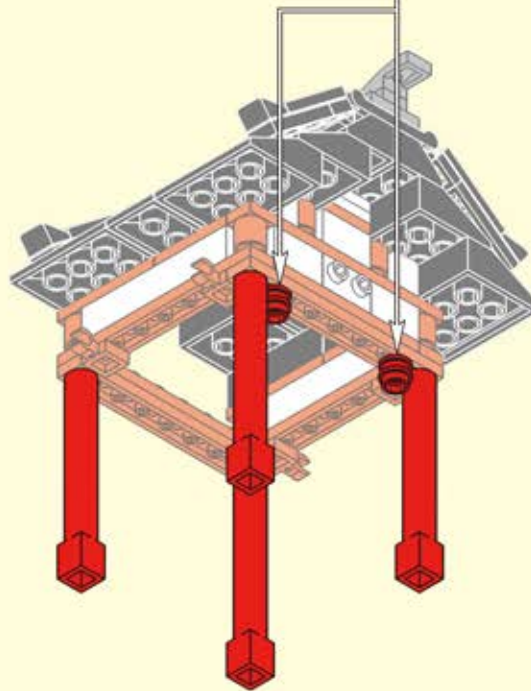
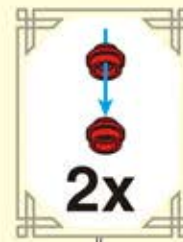

3-17

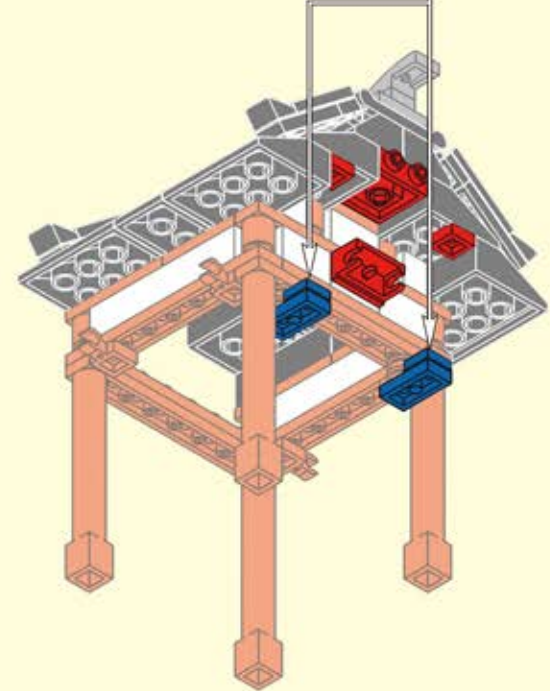

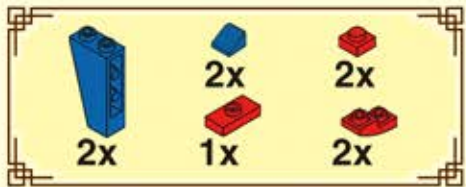

3-18

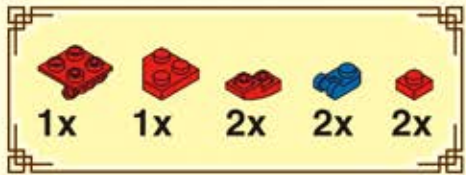
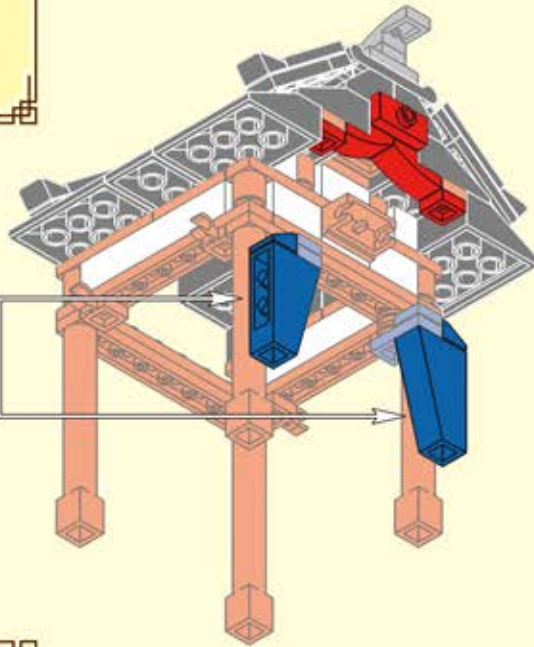
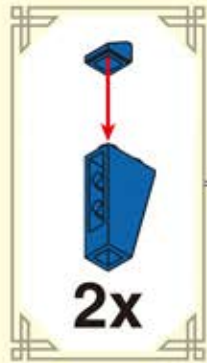

3-19

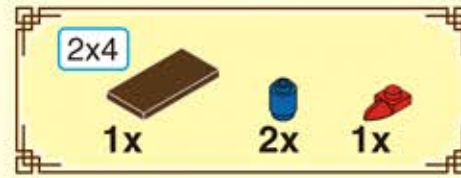
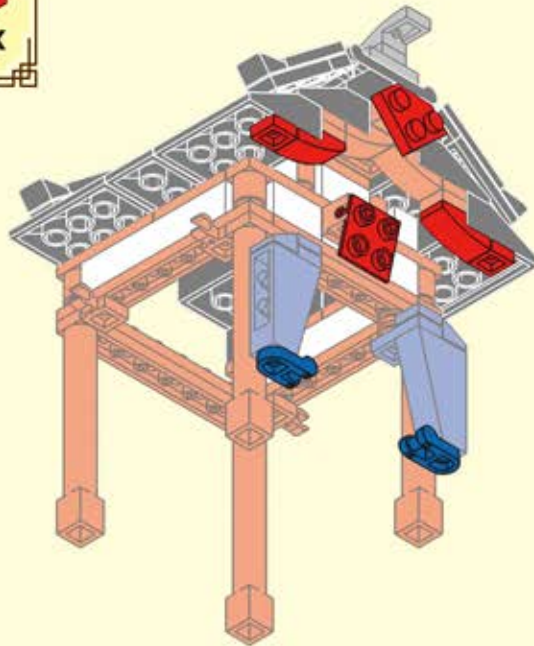

3-20



3-21

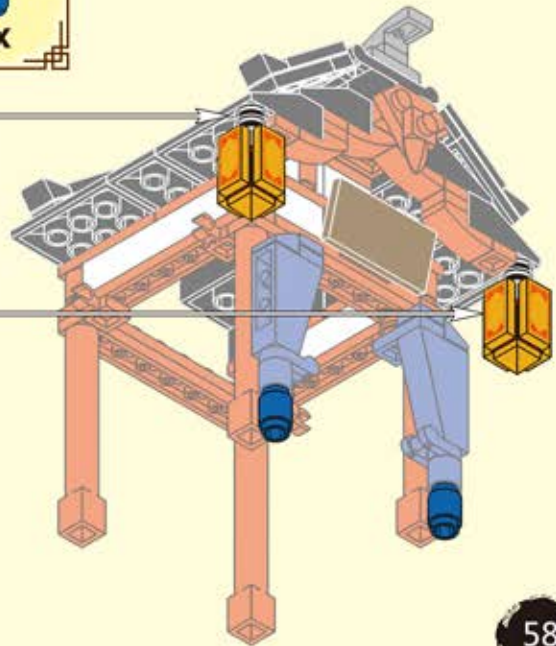
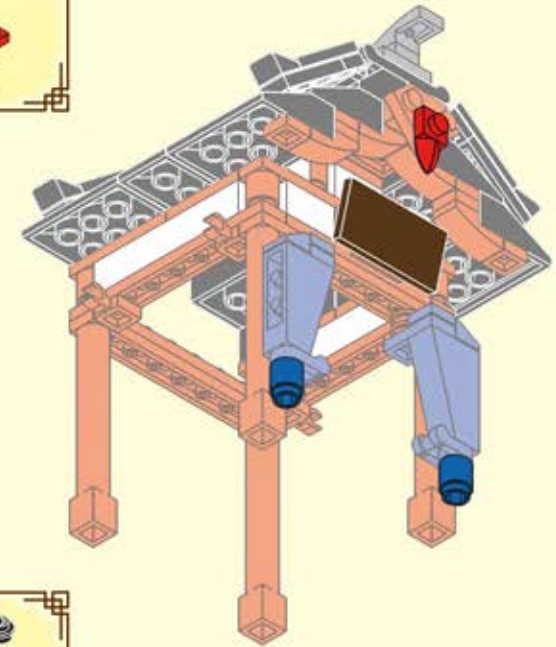

3-22



3-23

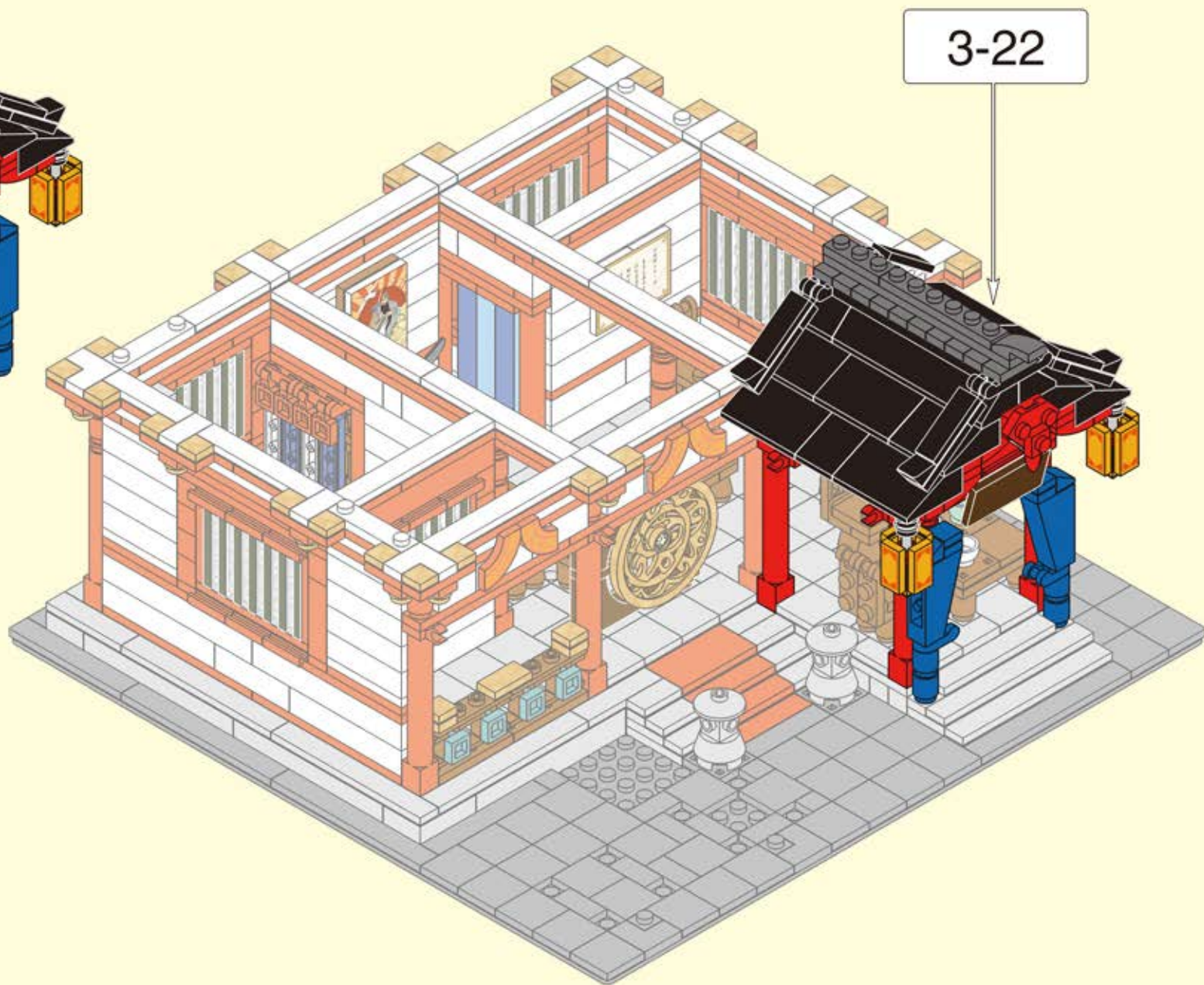
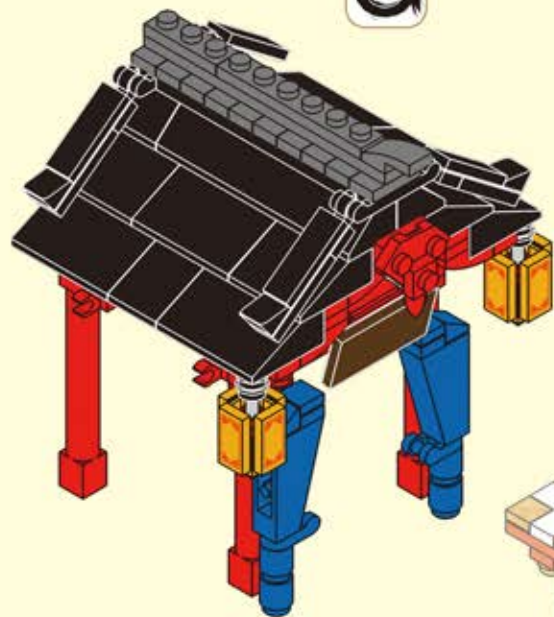

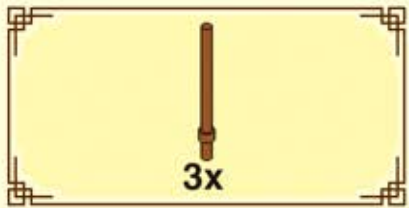

3-24



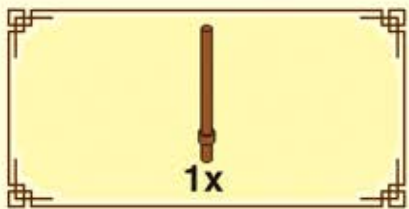



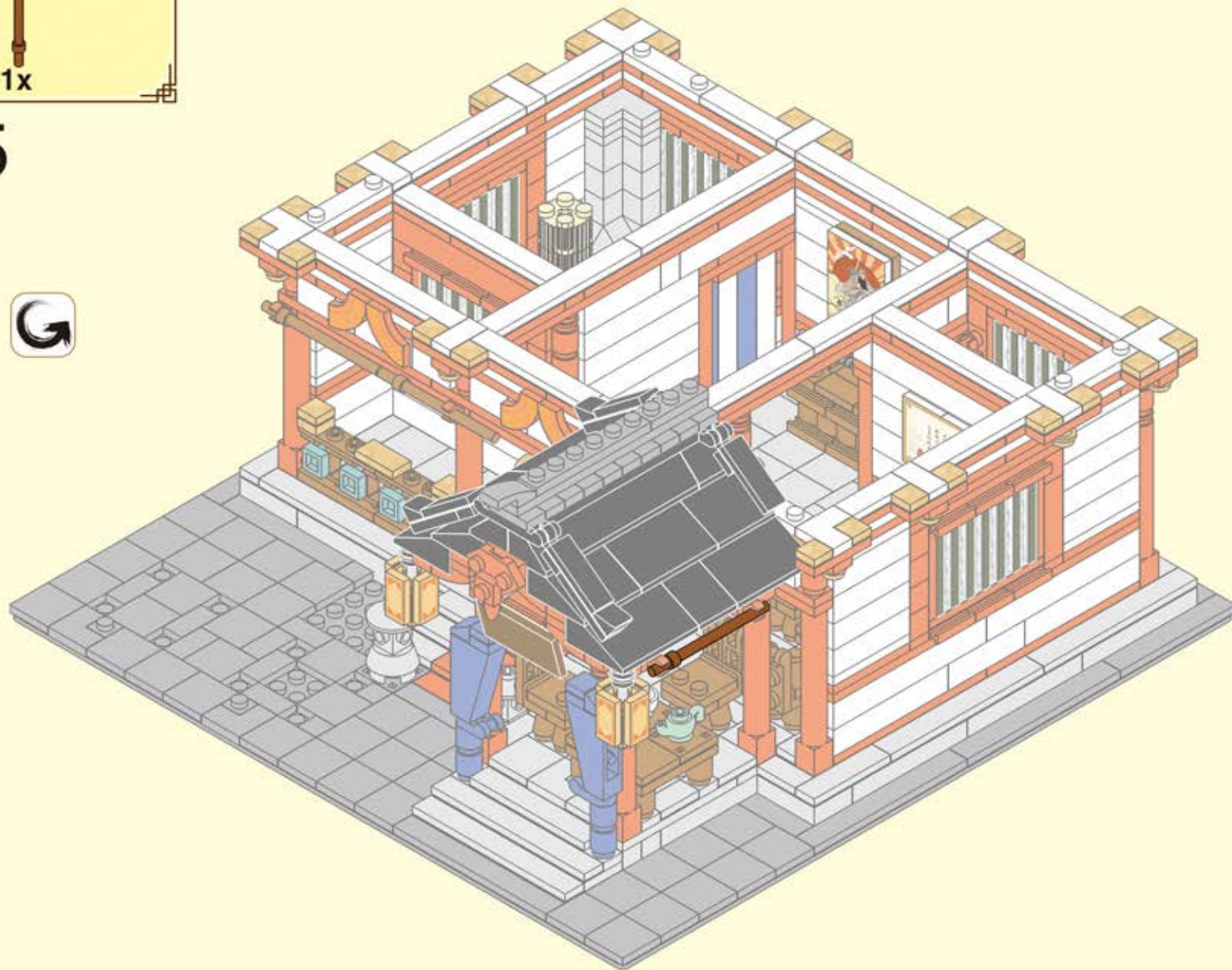





















3-25



		
24x	8x	32x

3-26











1		2	
			
			
			
			
			
			
			
			
			
			
			
			
			
			
			

		
9x	3x	12x

3-27



1		2	
			3x
			
			
			
			
			

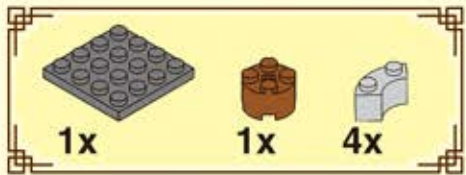

3-28

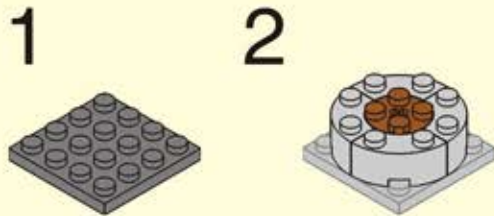

3-29

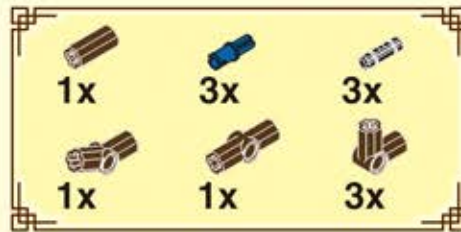

3-30

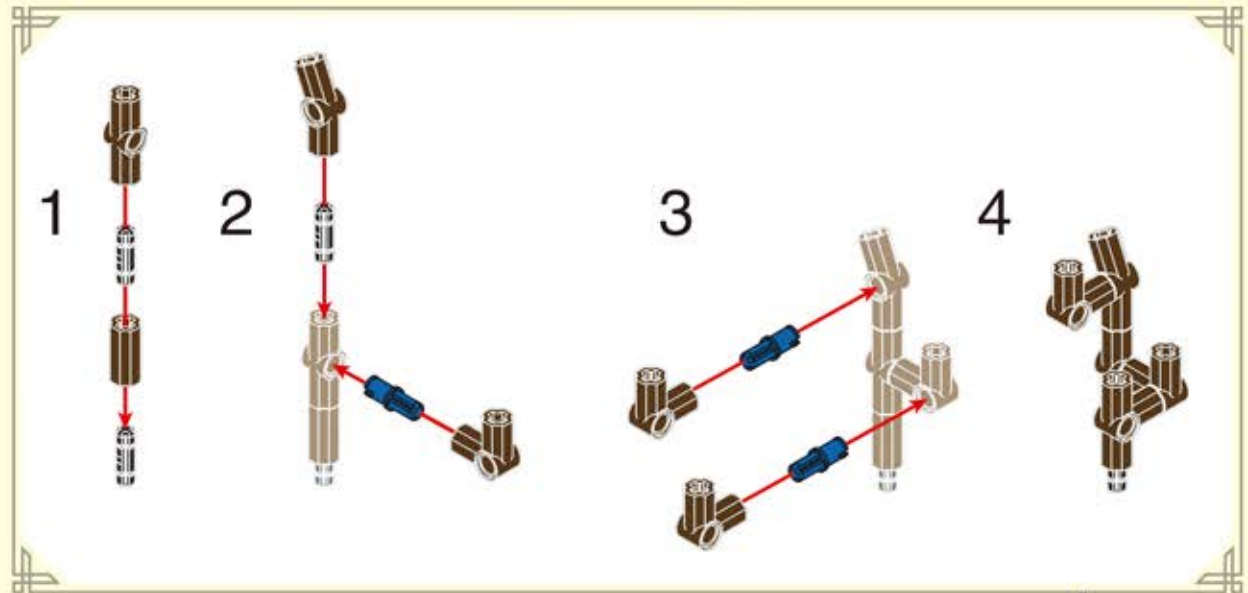

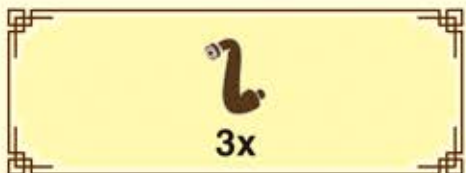

3-31

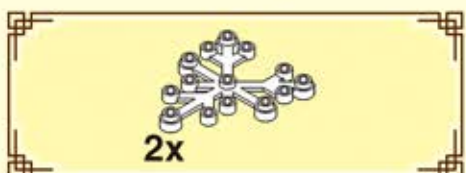
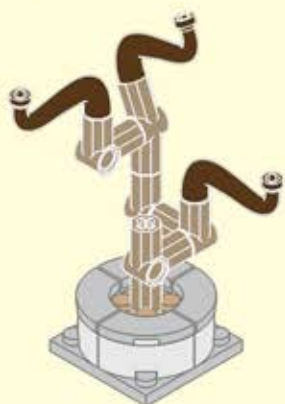

3-32

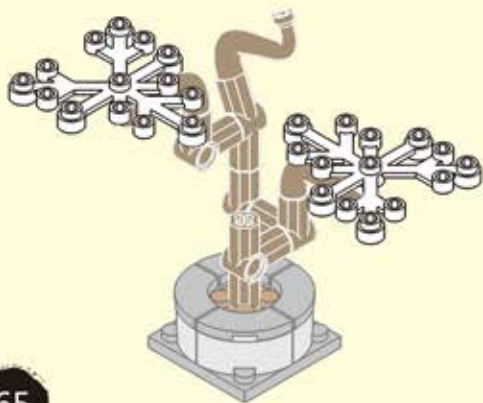

3-33

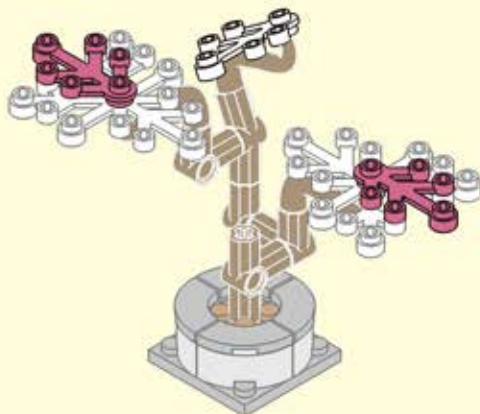

3-34

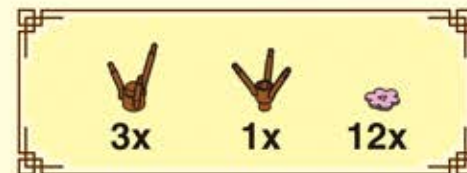
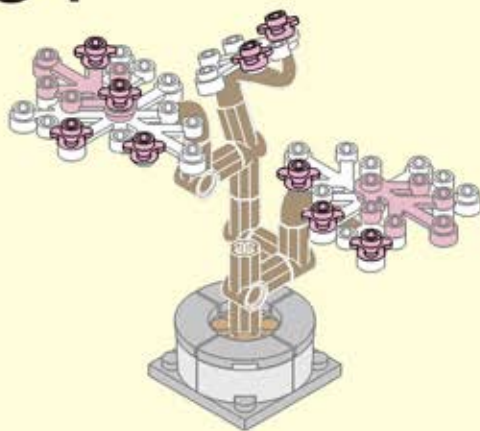

3-35

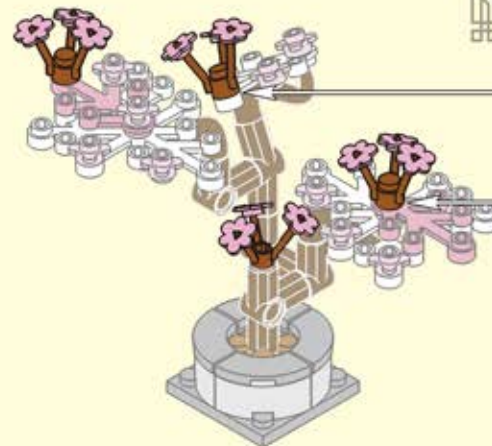

3-36



3-37



3-36



3-38

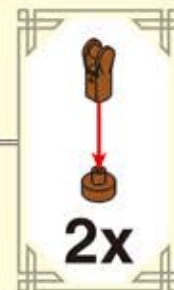



3-39

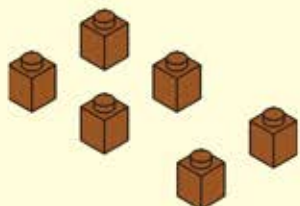

3-40

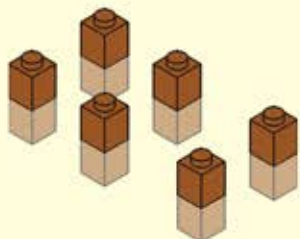

3-41

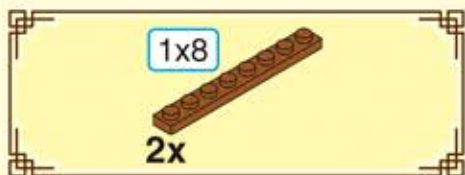
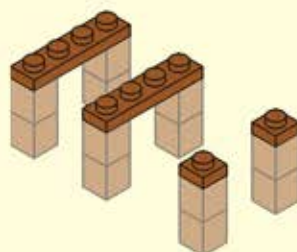

3-42

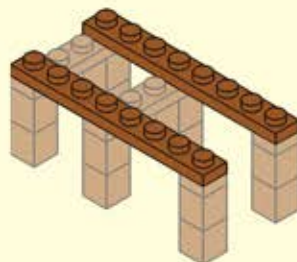

3-43

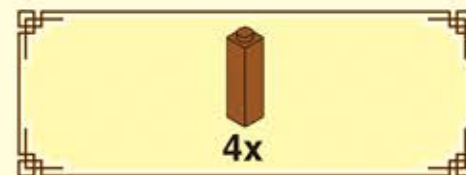
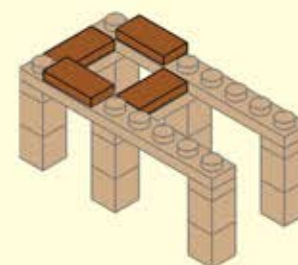

3-44

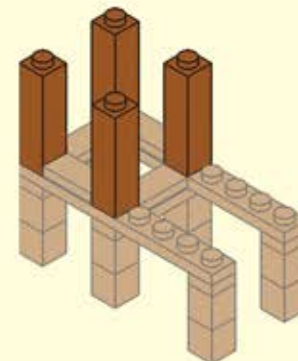



3-45

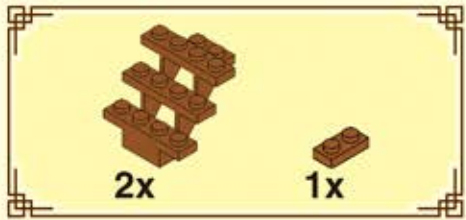

3-46

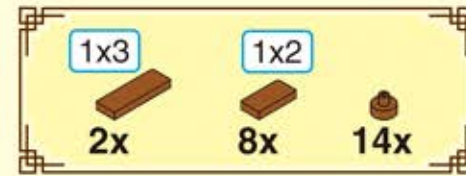
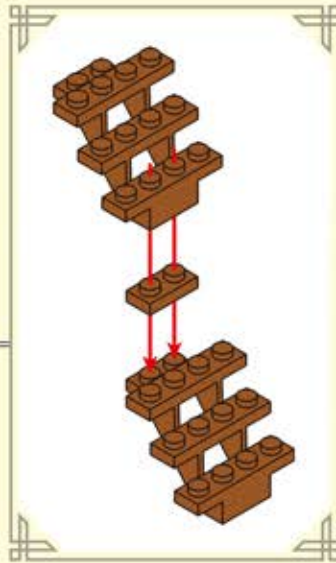
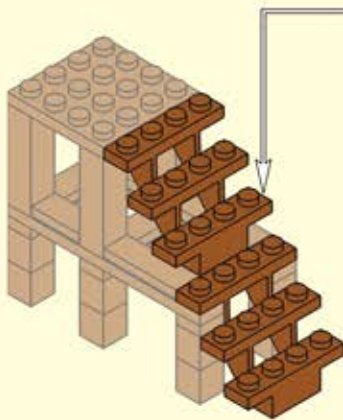

3-47

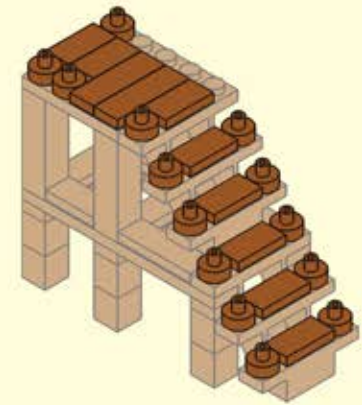

3-48

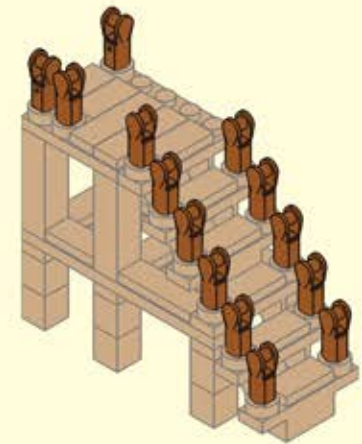



3-49

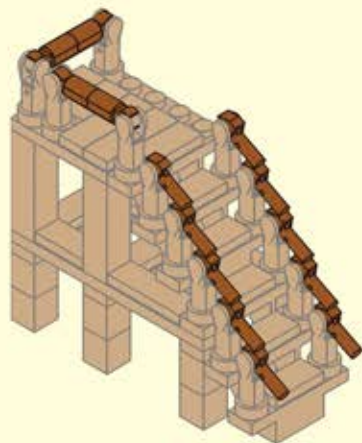

3-50

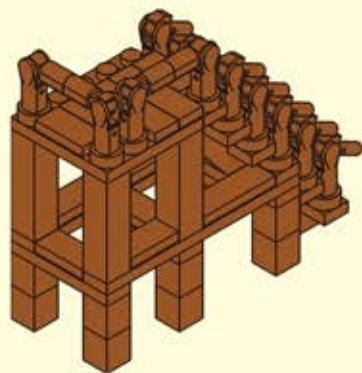

3-51

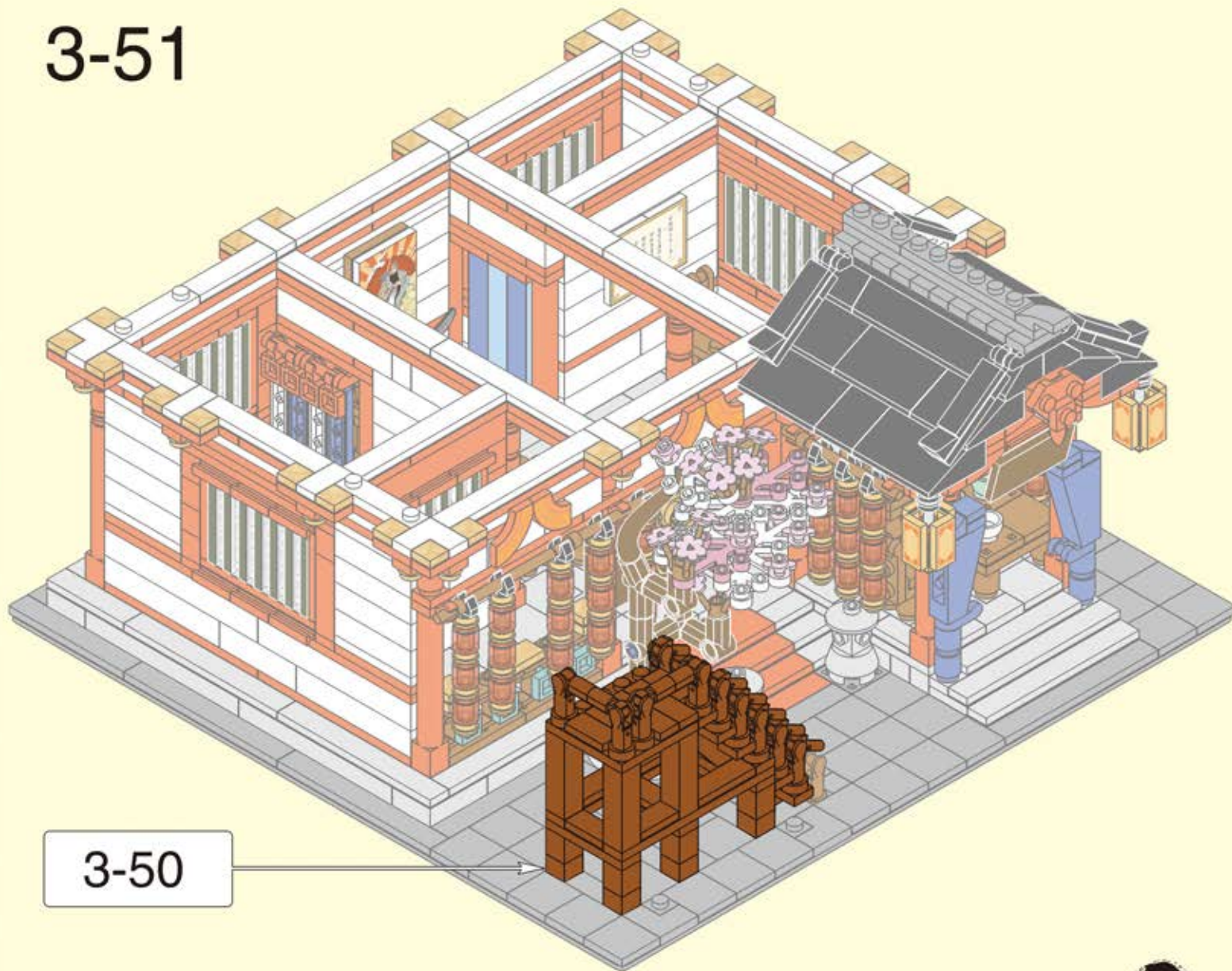



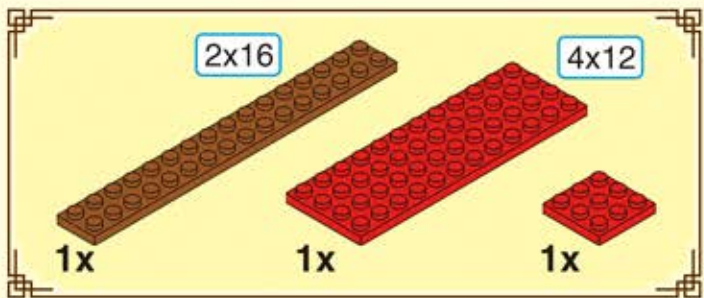

## 4-1

1

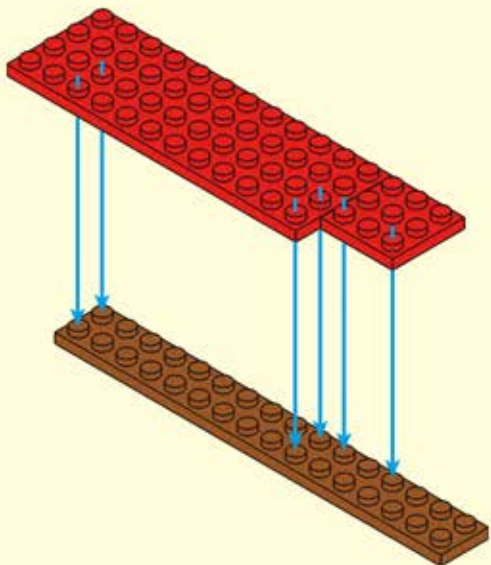

2

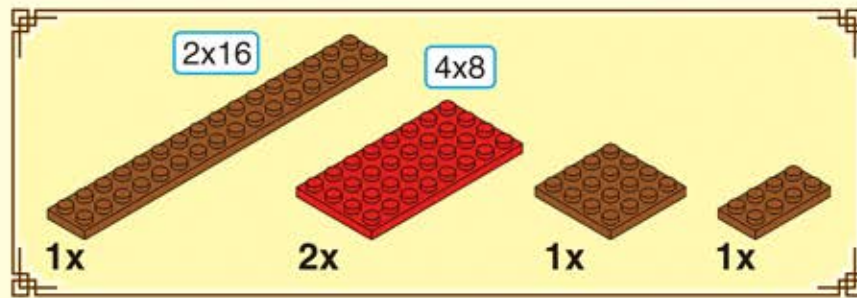
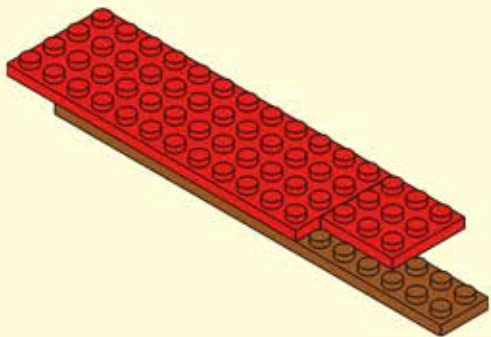

## 4-2

1

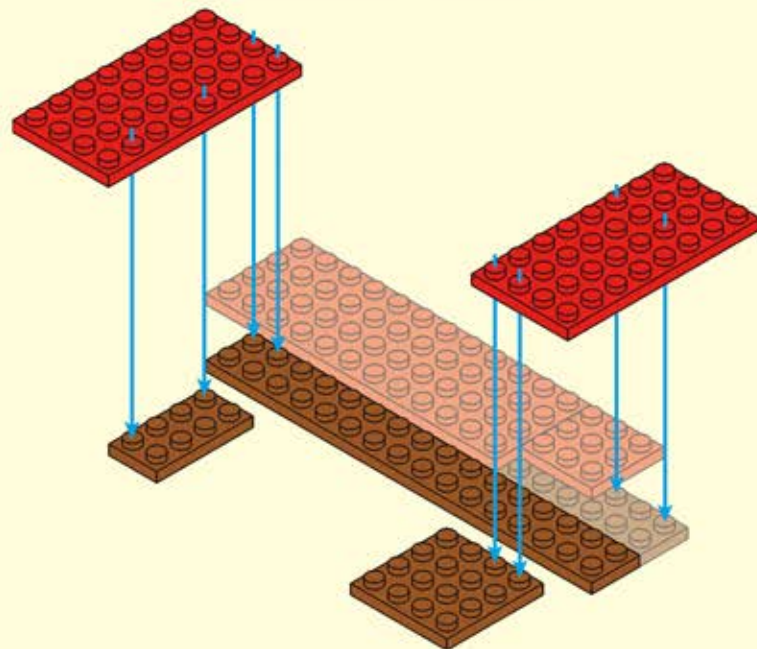

2

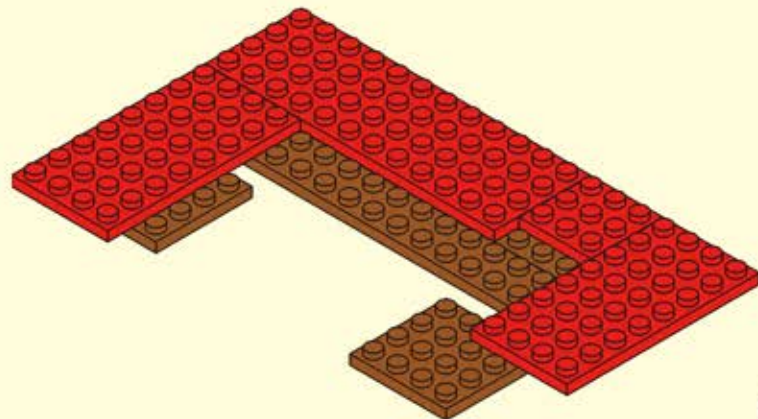

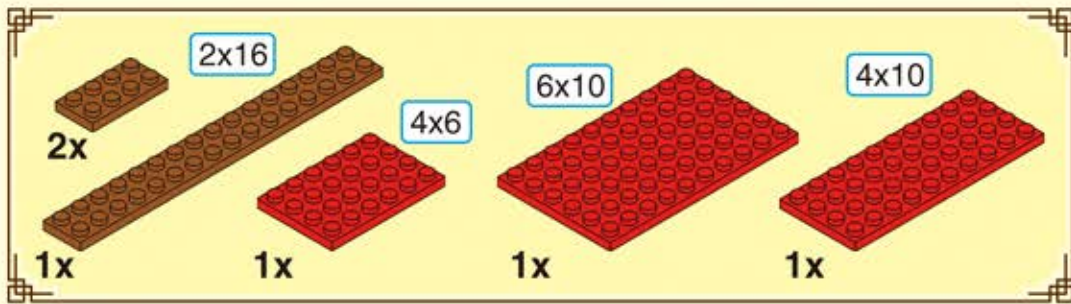

4-3

1

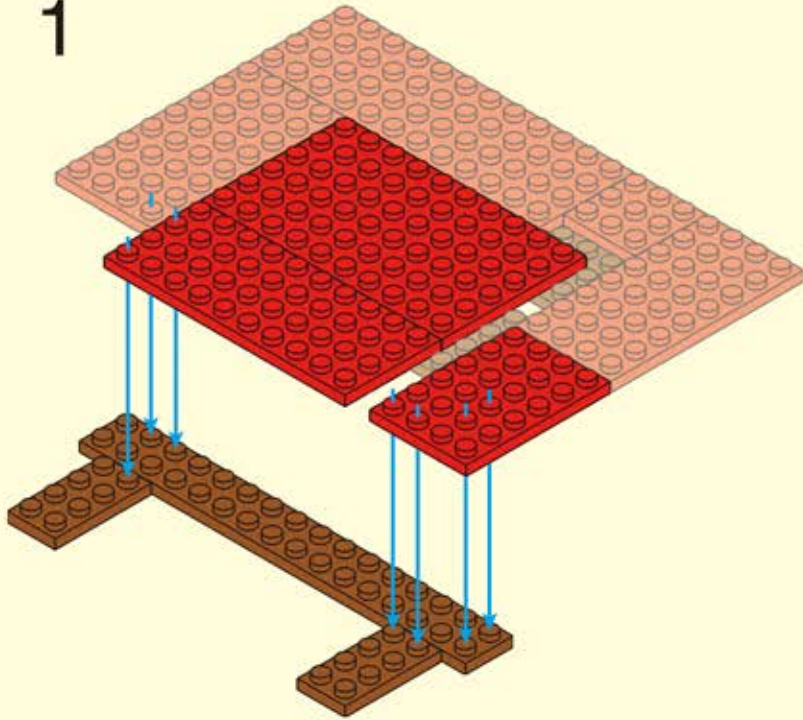

2

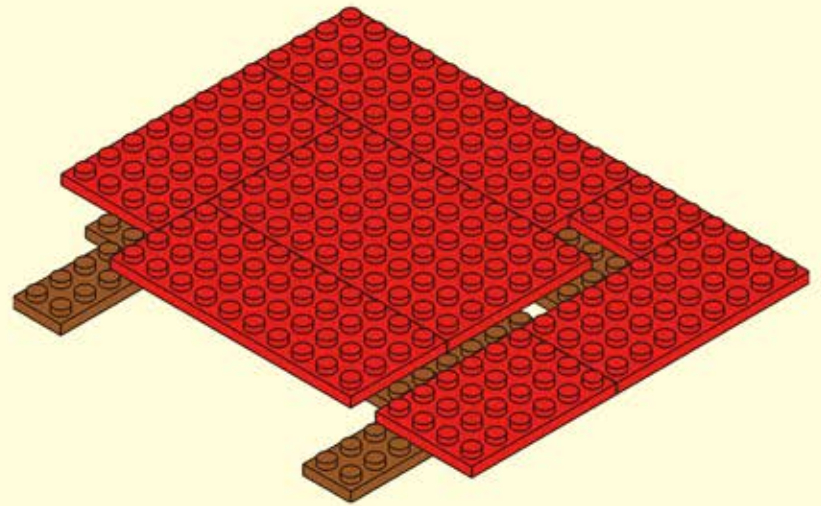

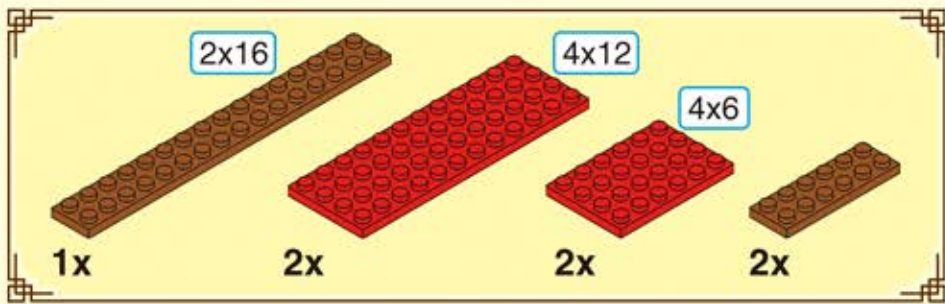

# 4-4

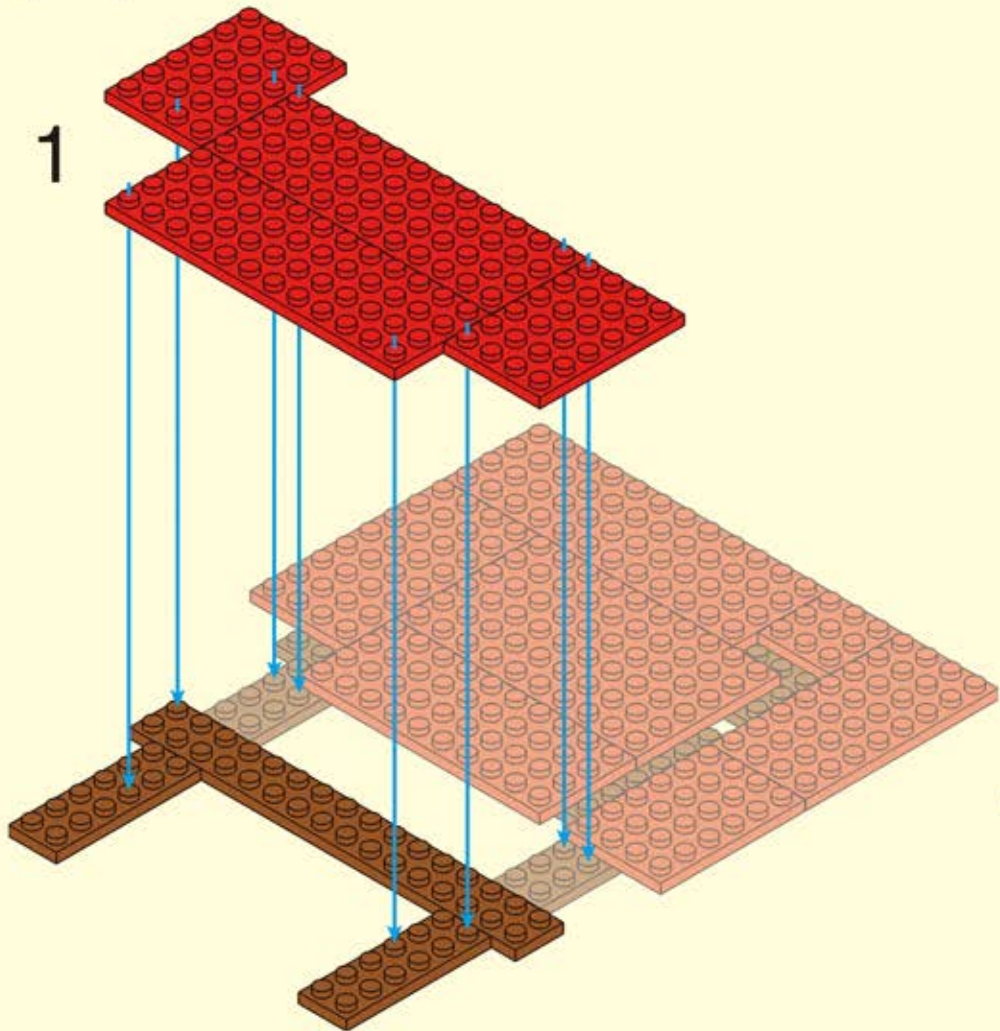

2

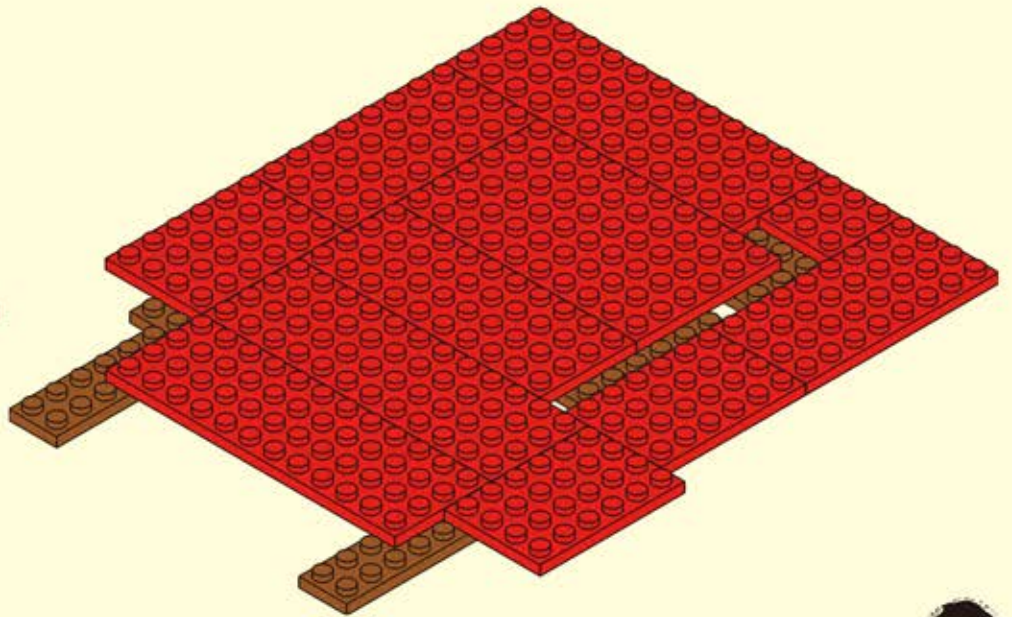

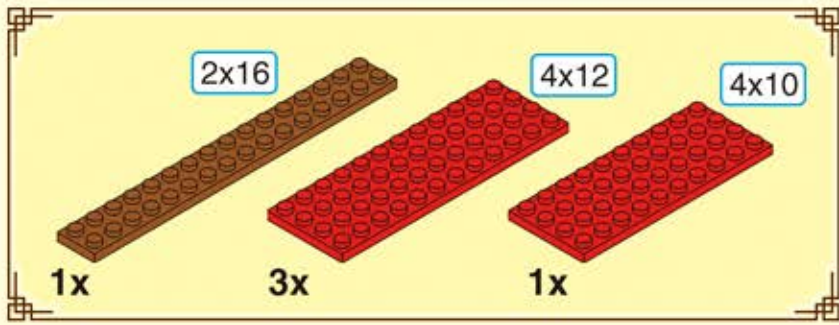

4-5

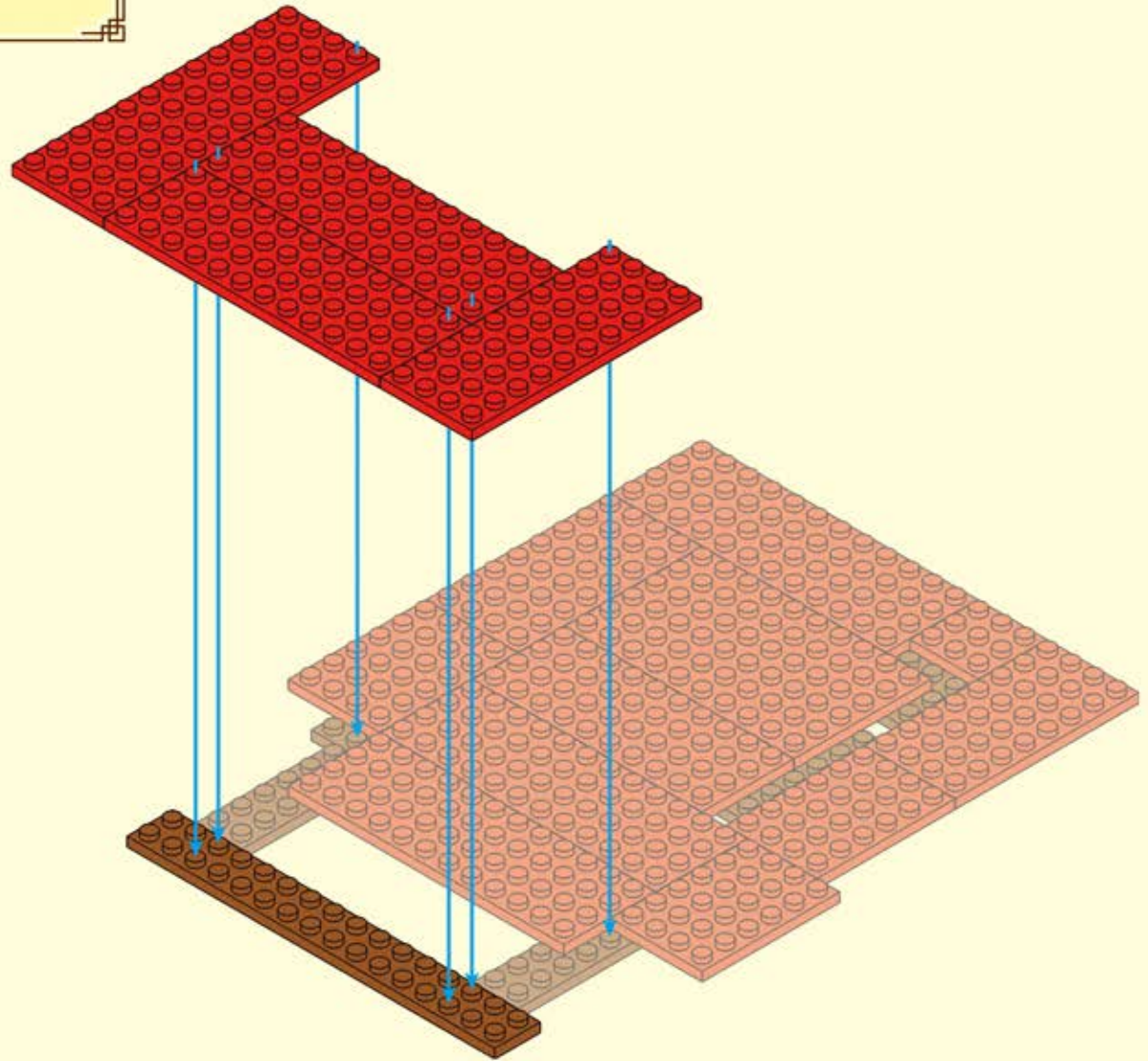

4-6

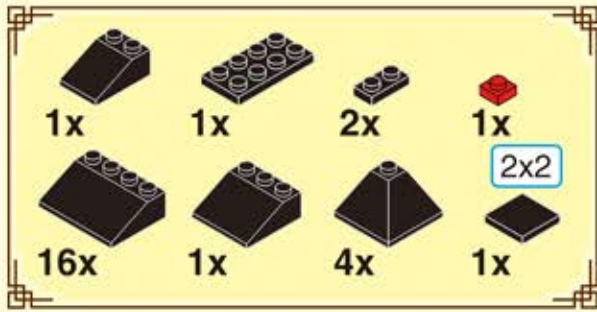
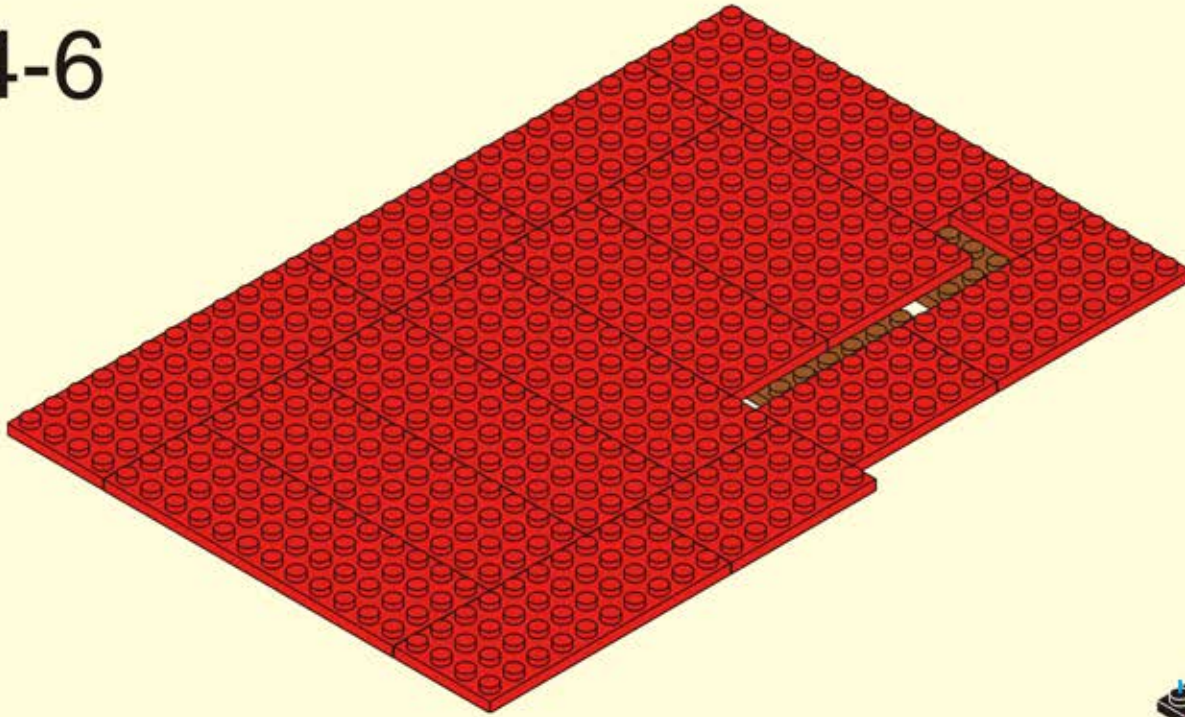

4-7

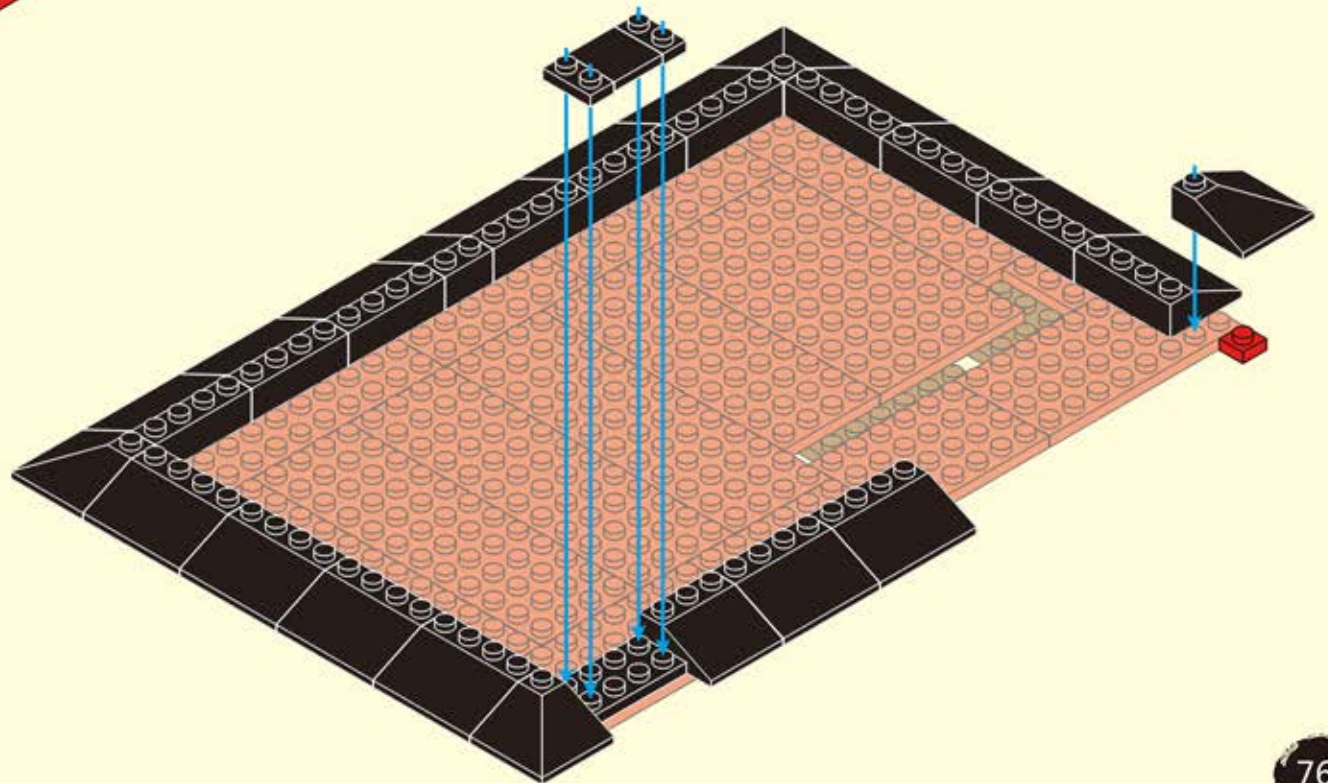



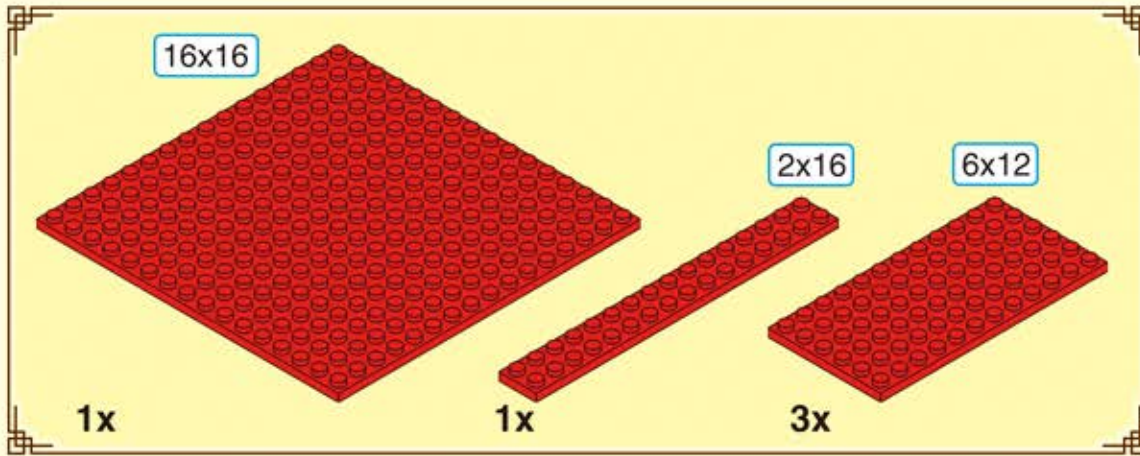

4-9

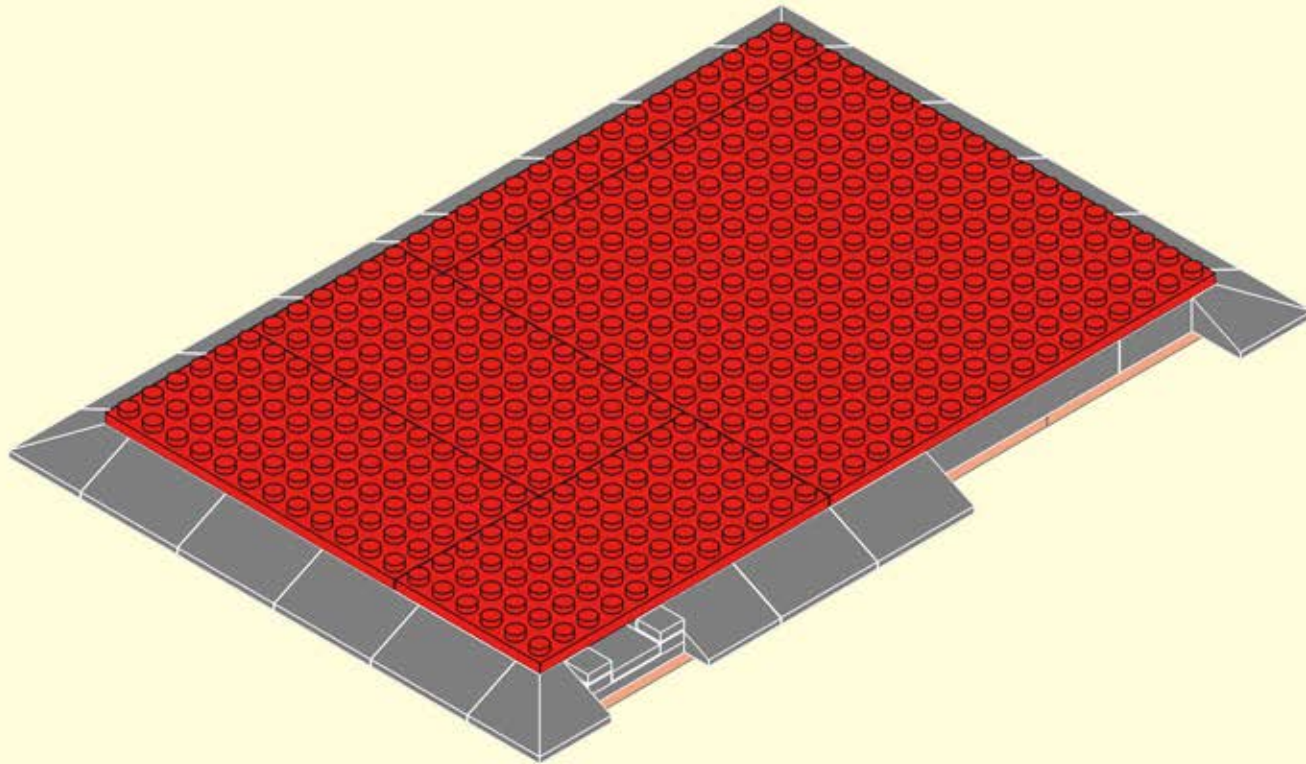

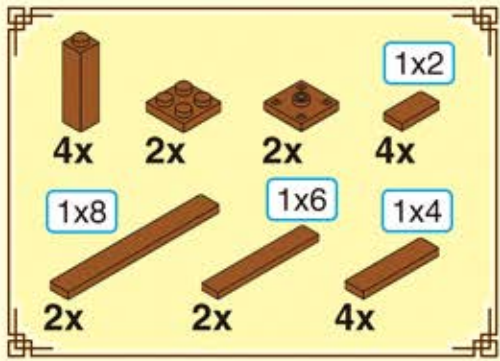

4-10

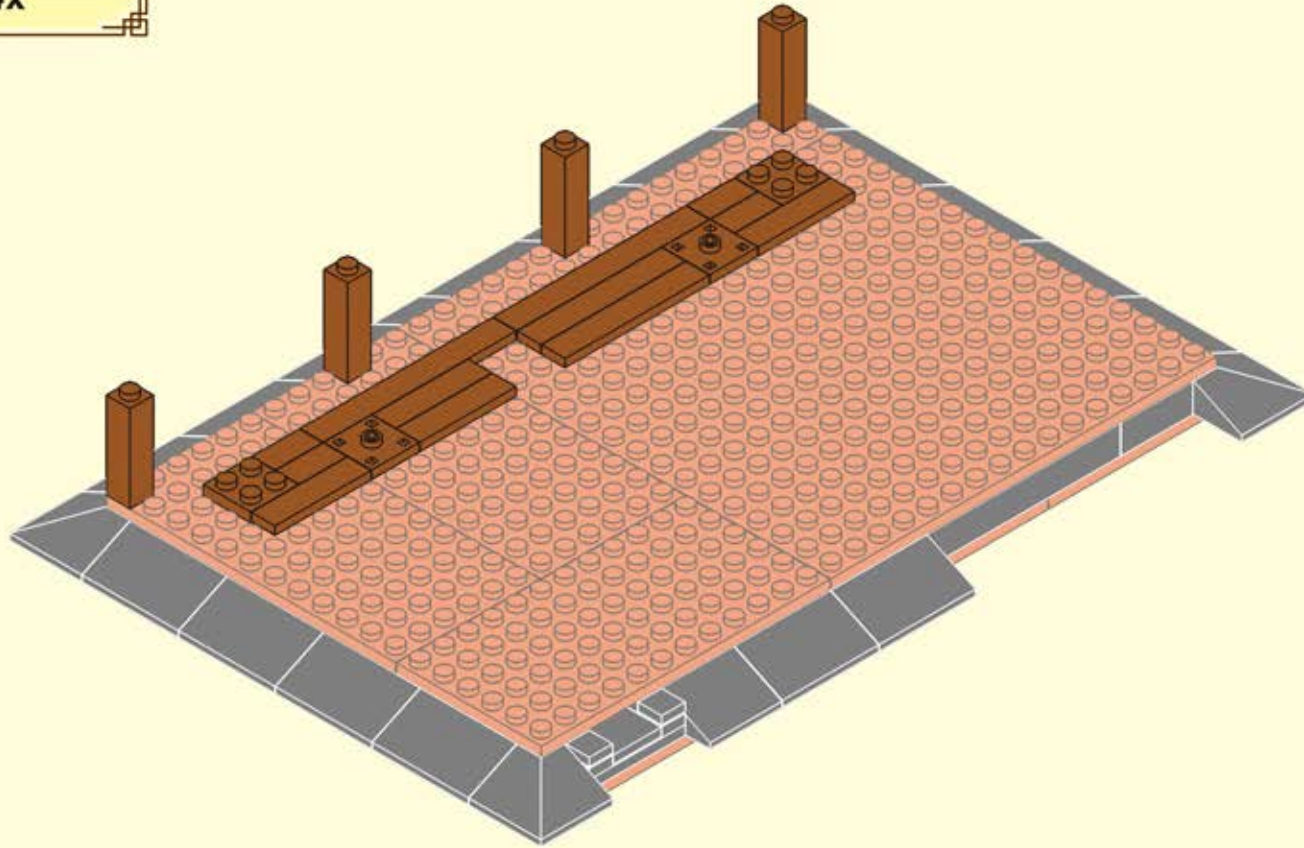

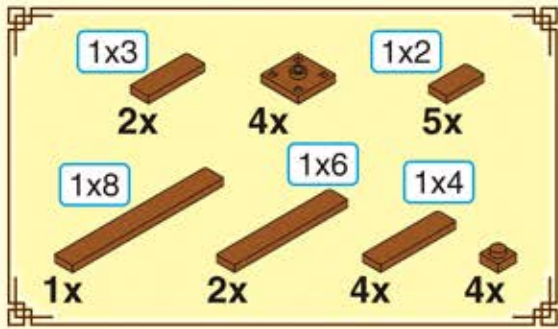

4-11

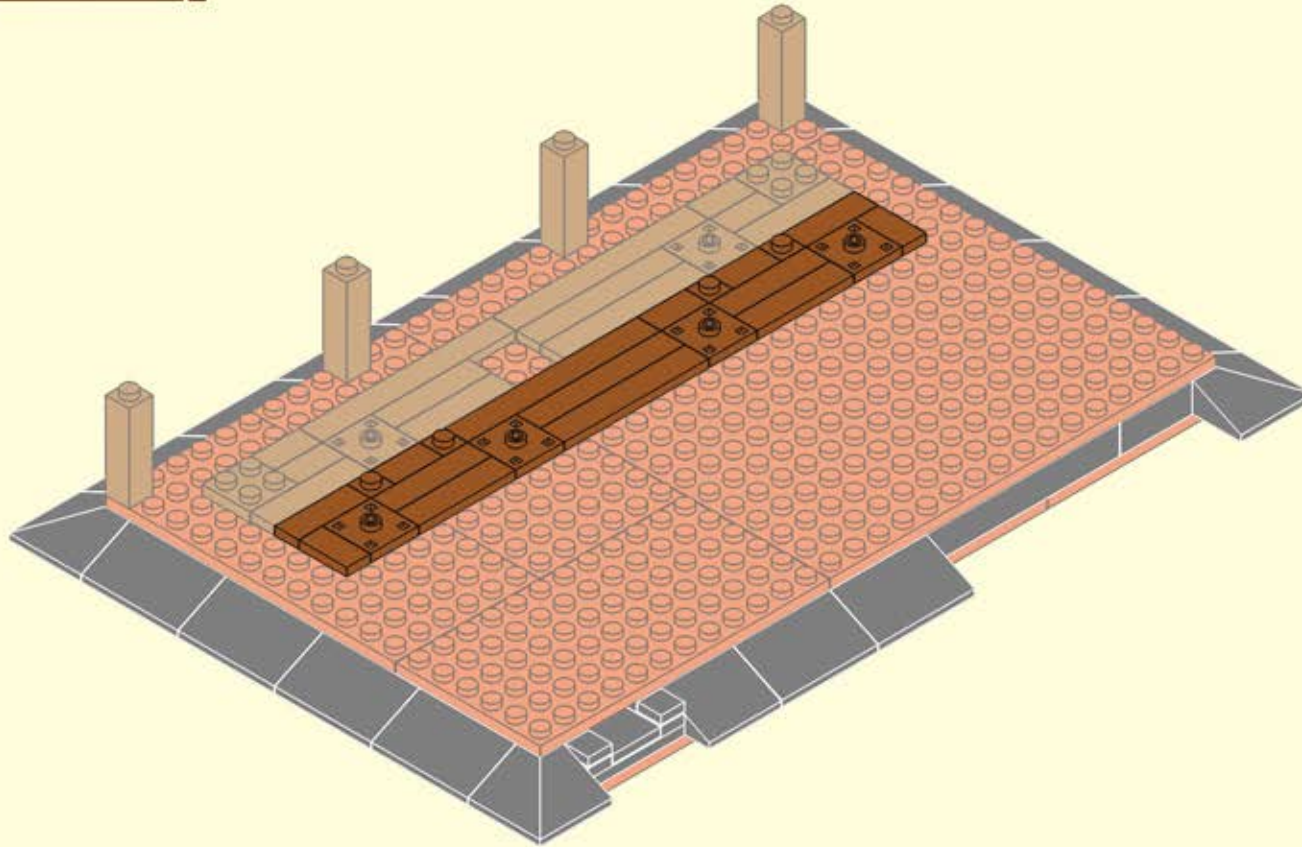

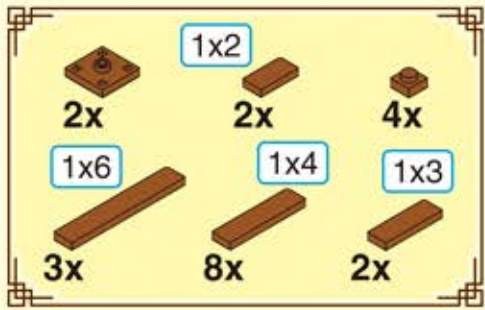

4-12

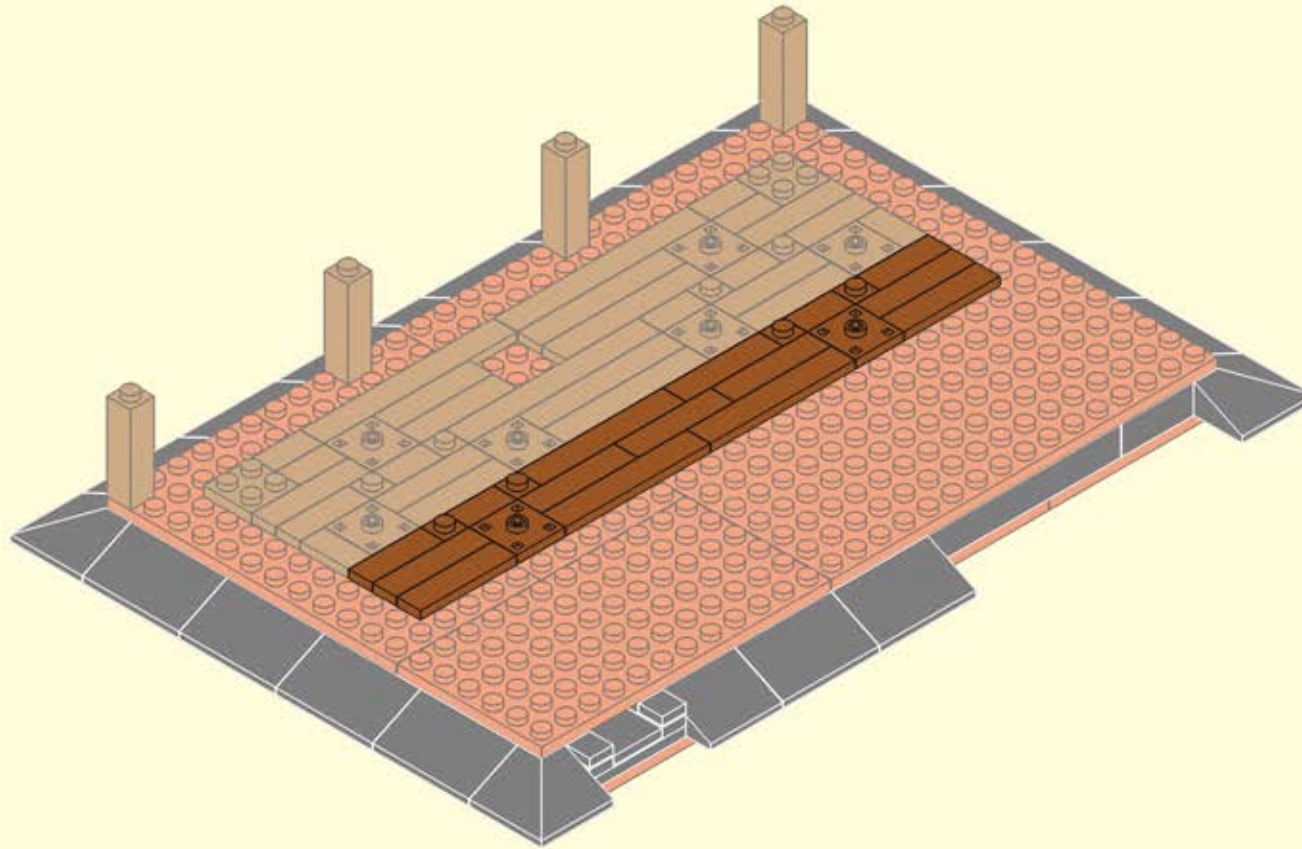

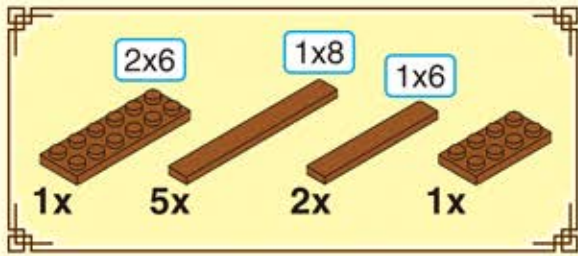

4-13

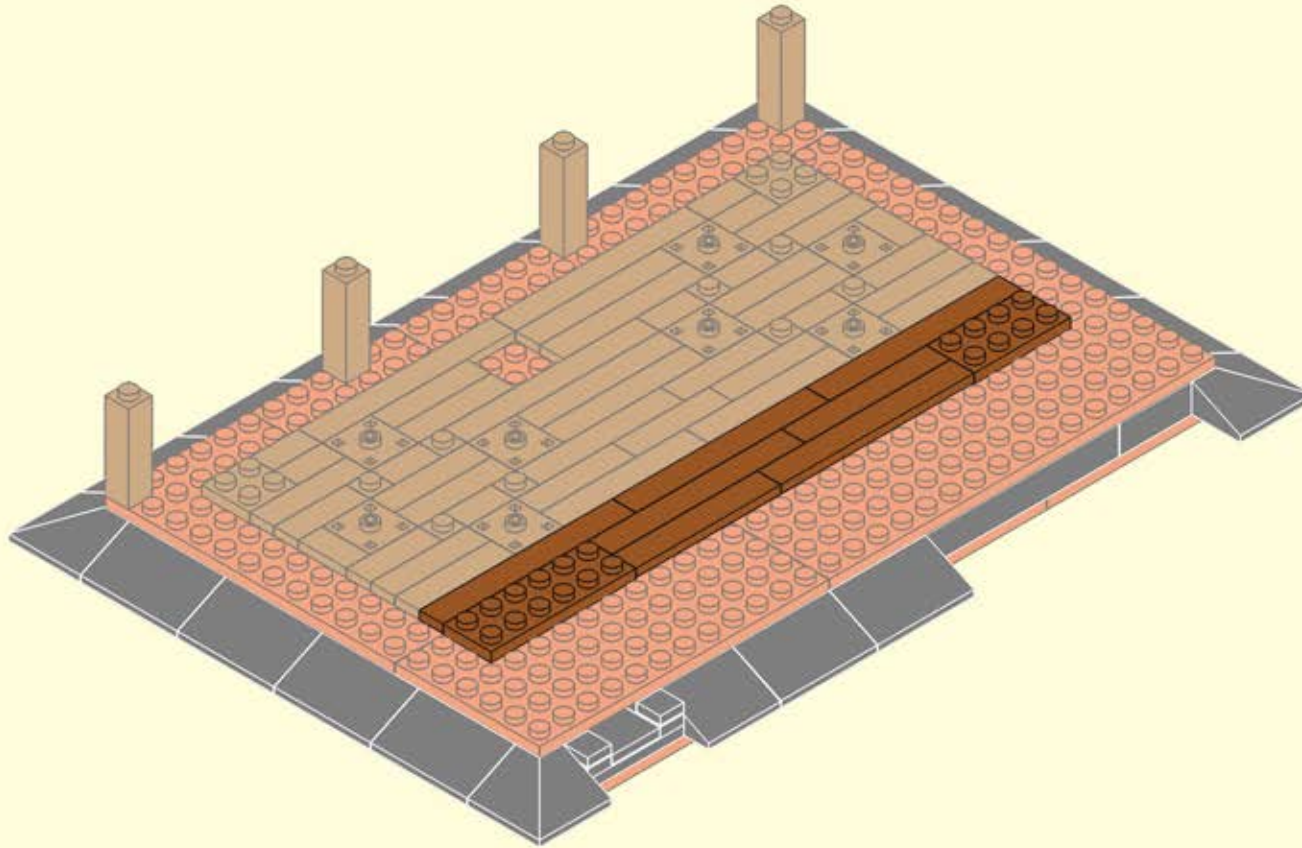

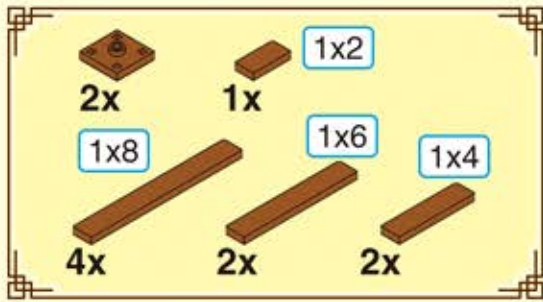

4-14

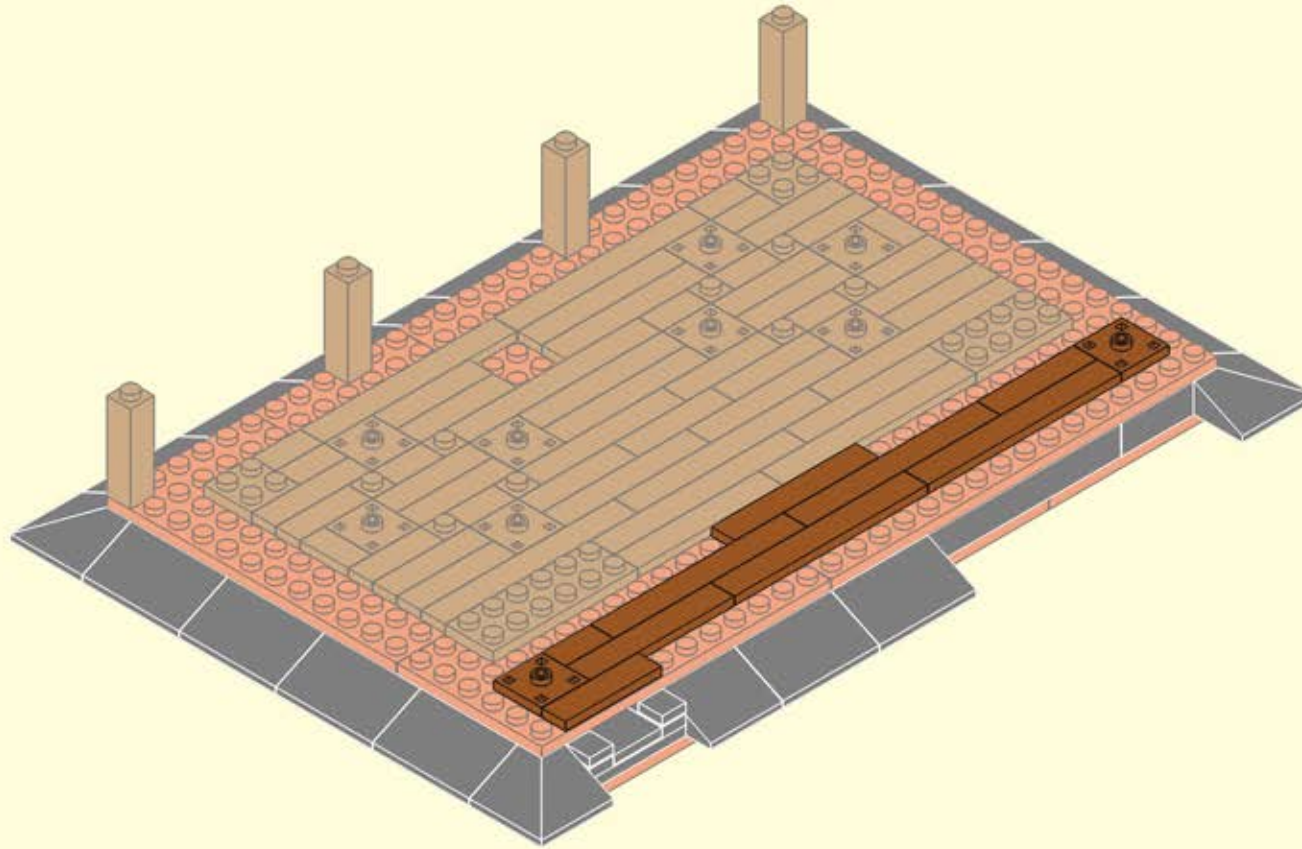

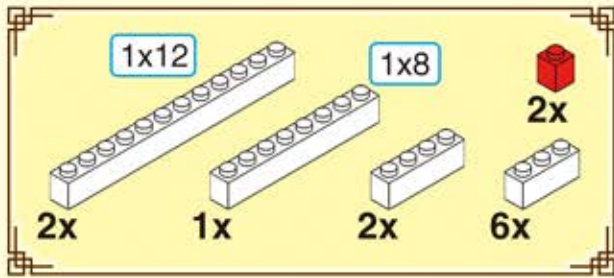

4-15

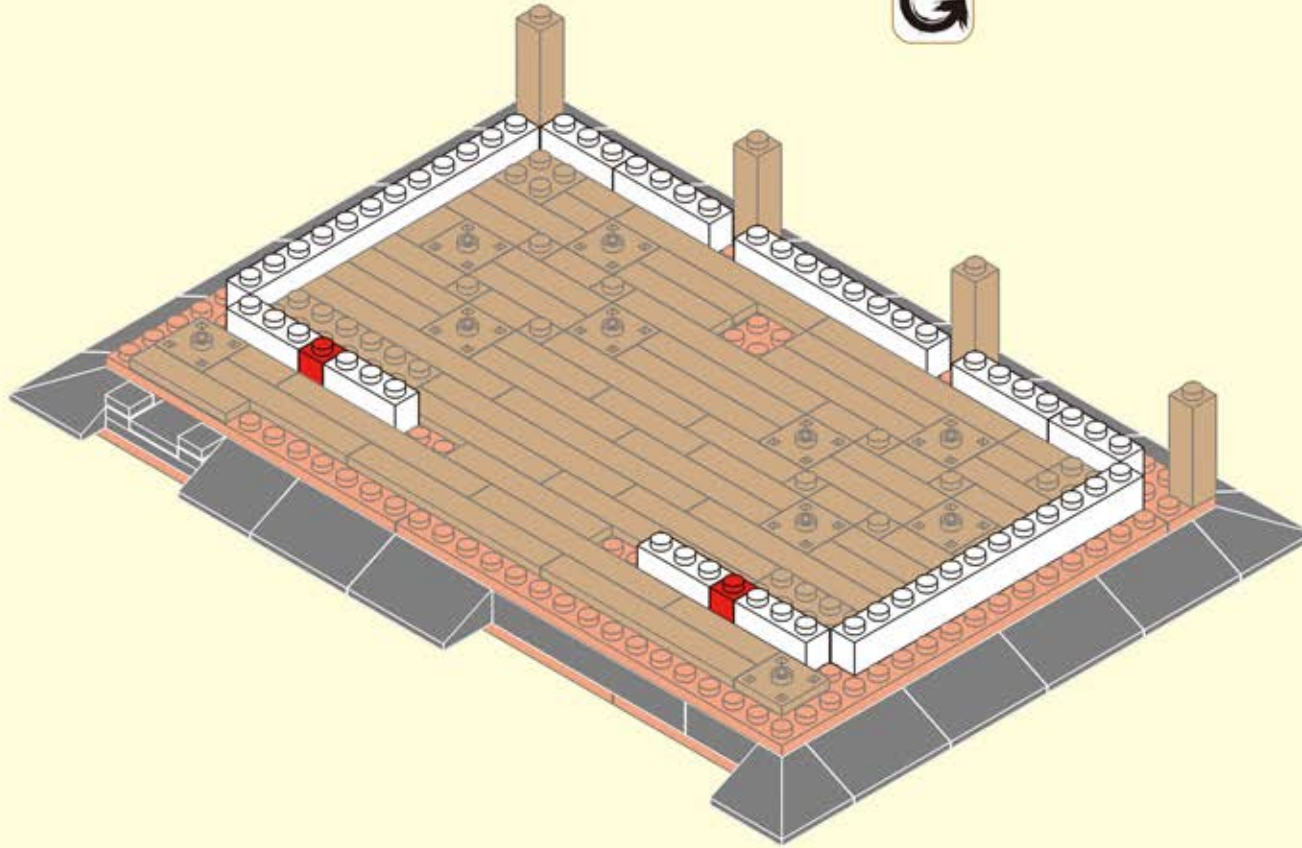



4-16





4-17

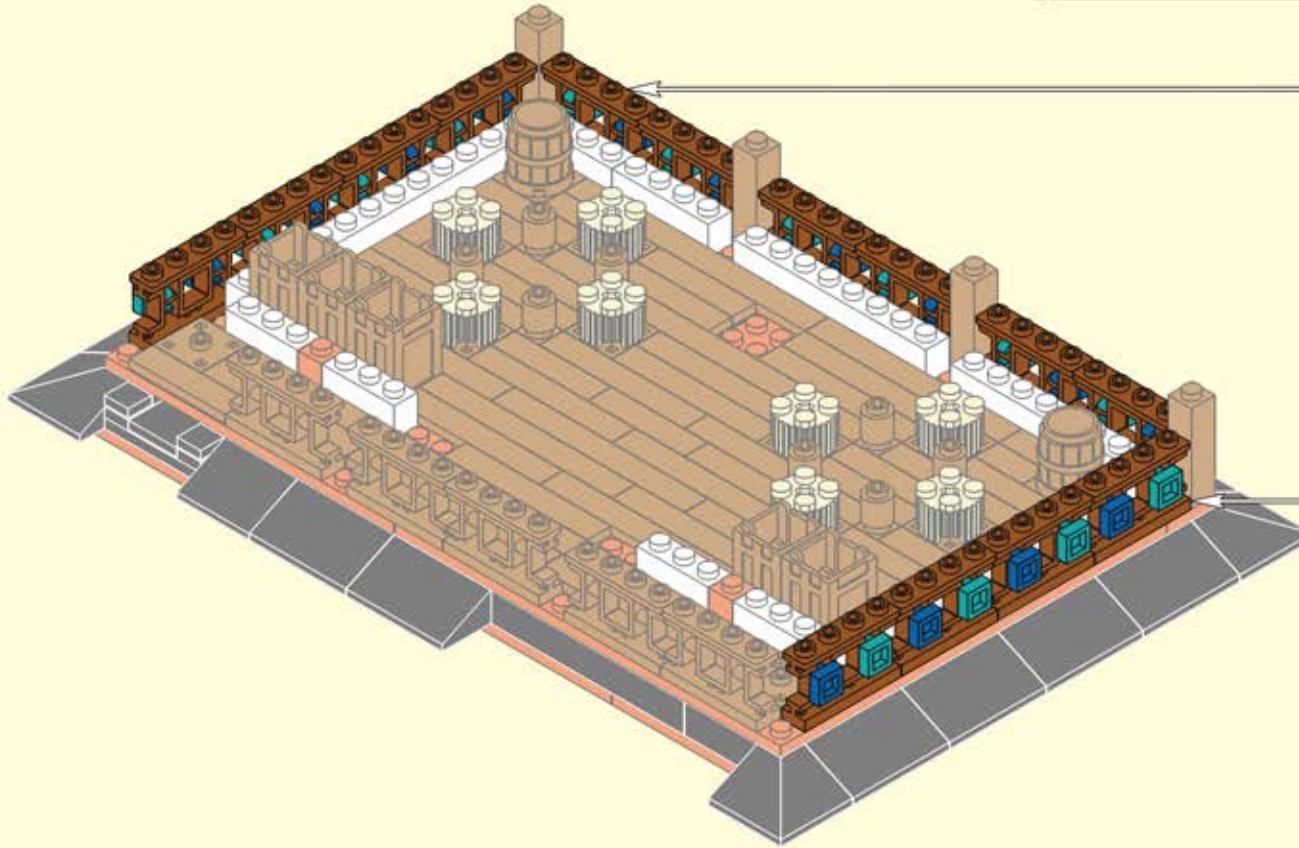
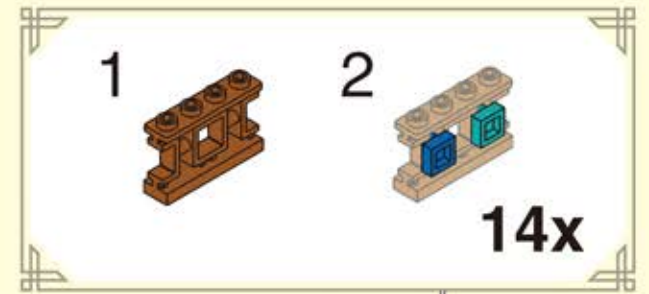

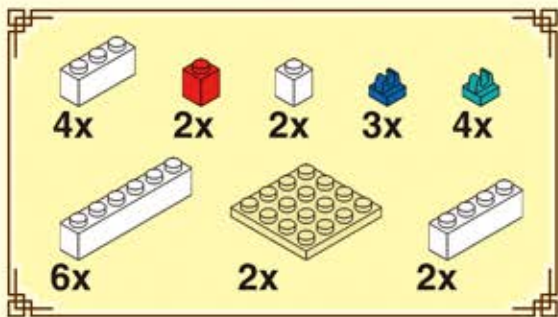

4-18

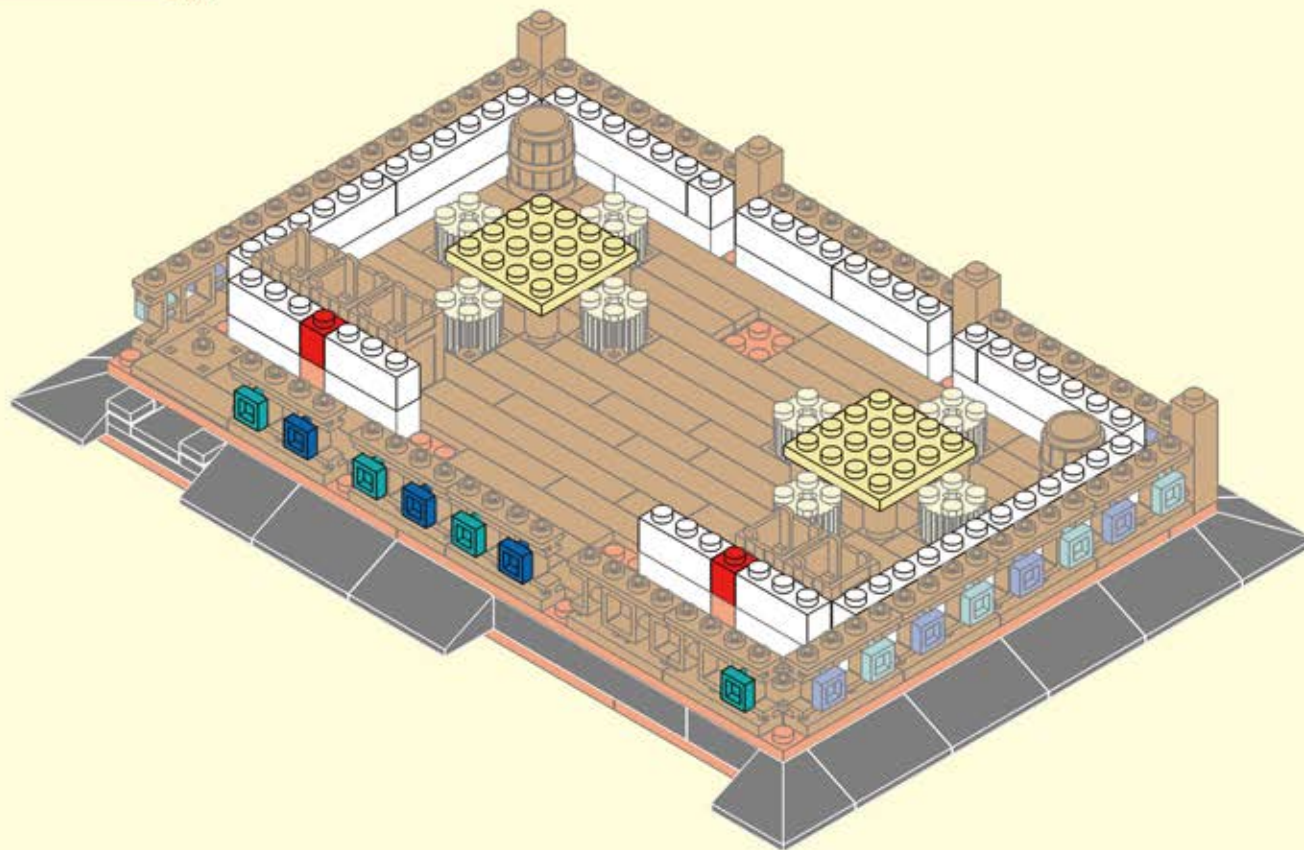

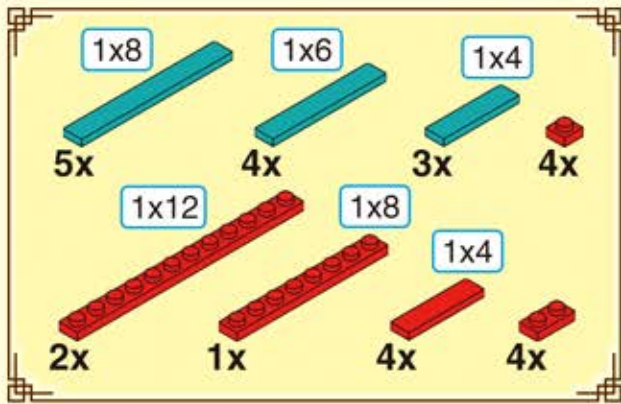

4-19

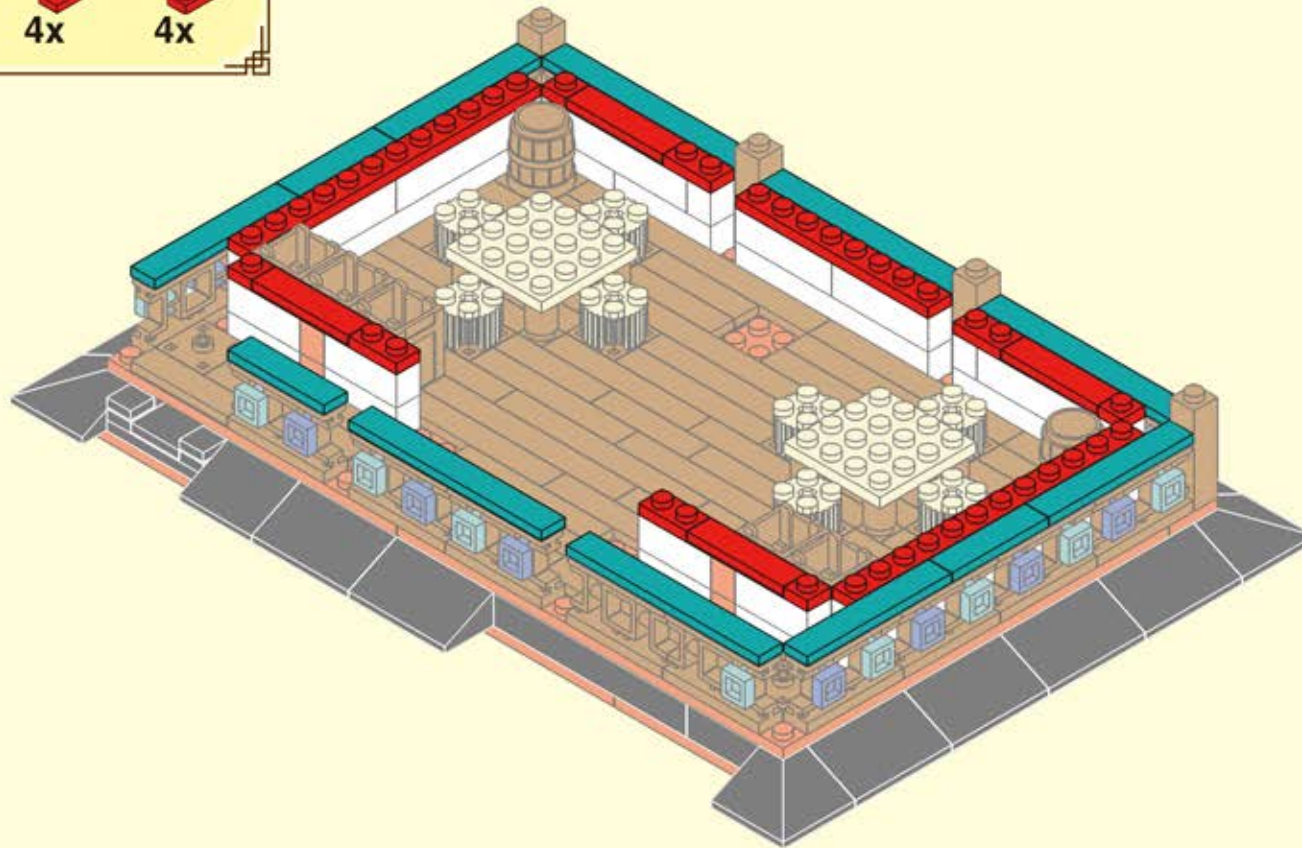

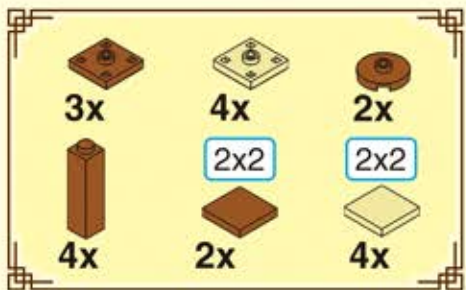

4-20

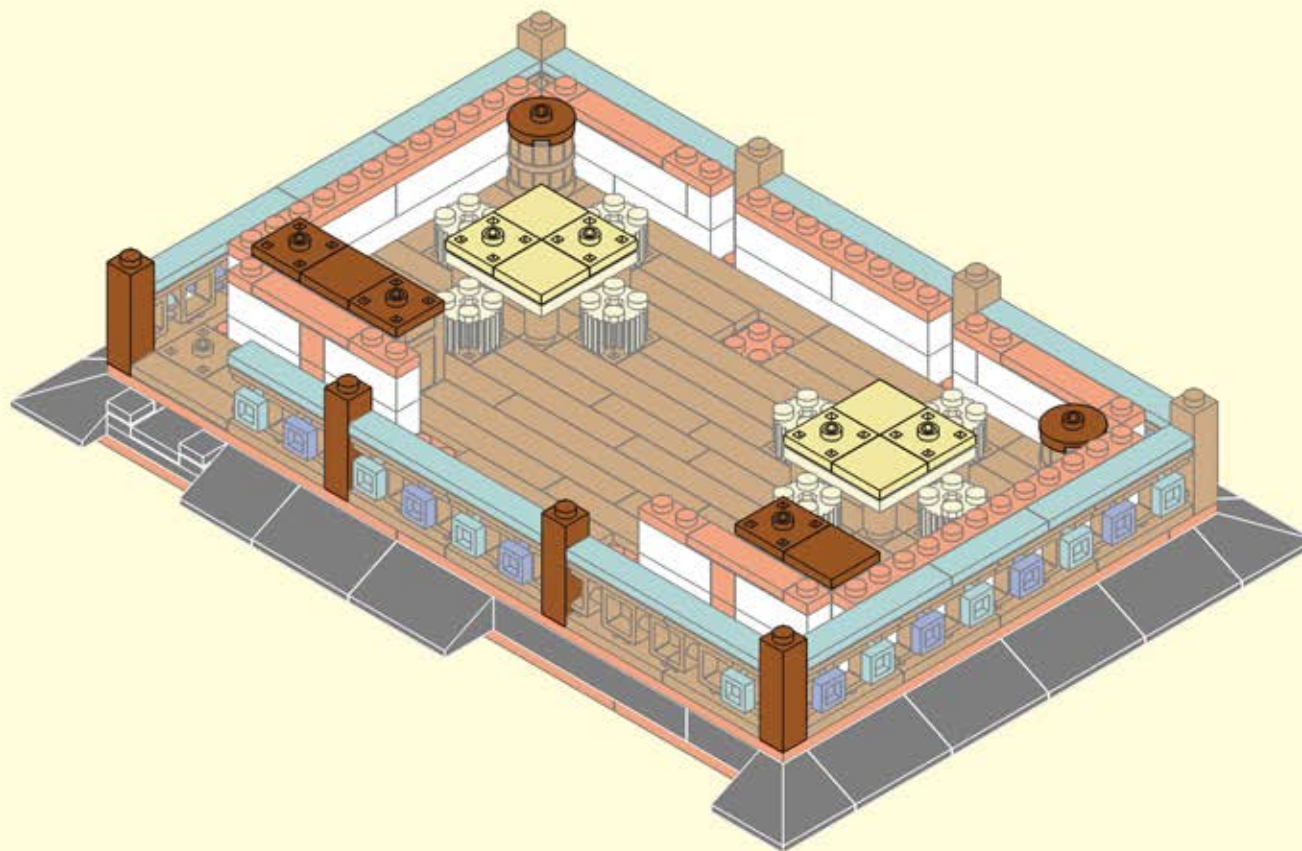



4-21

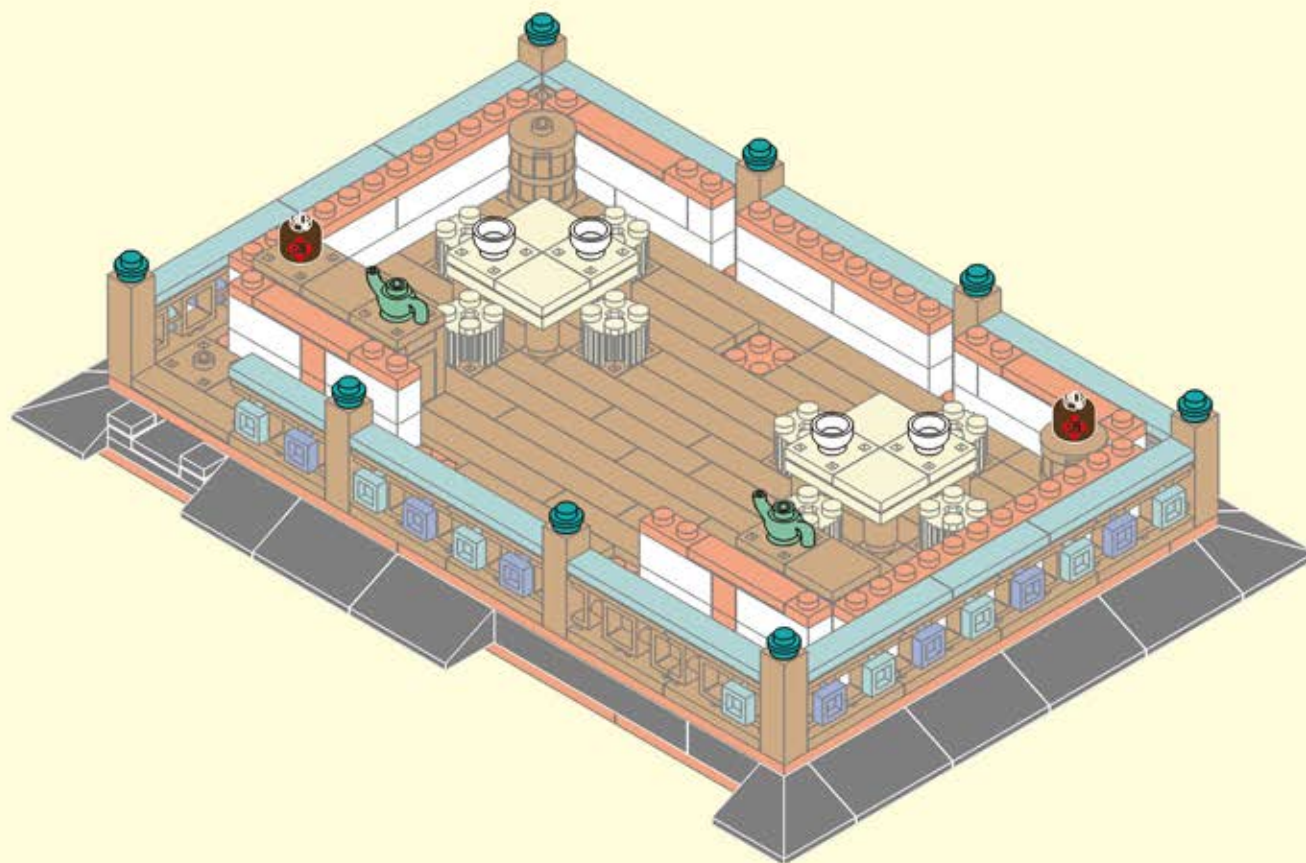

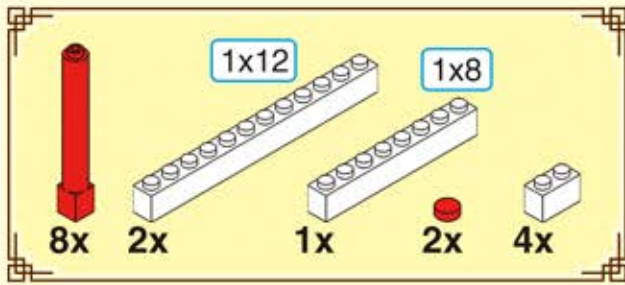

4-22

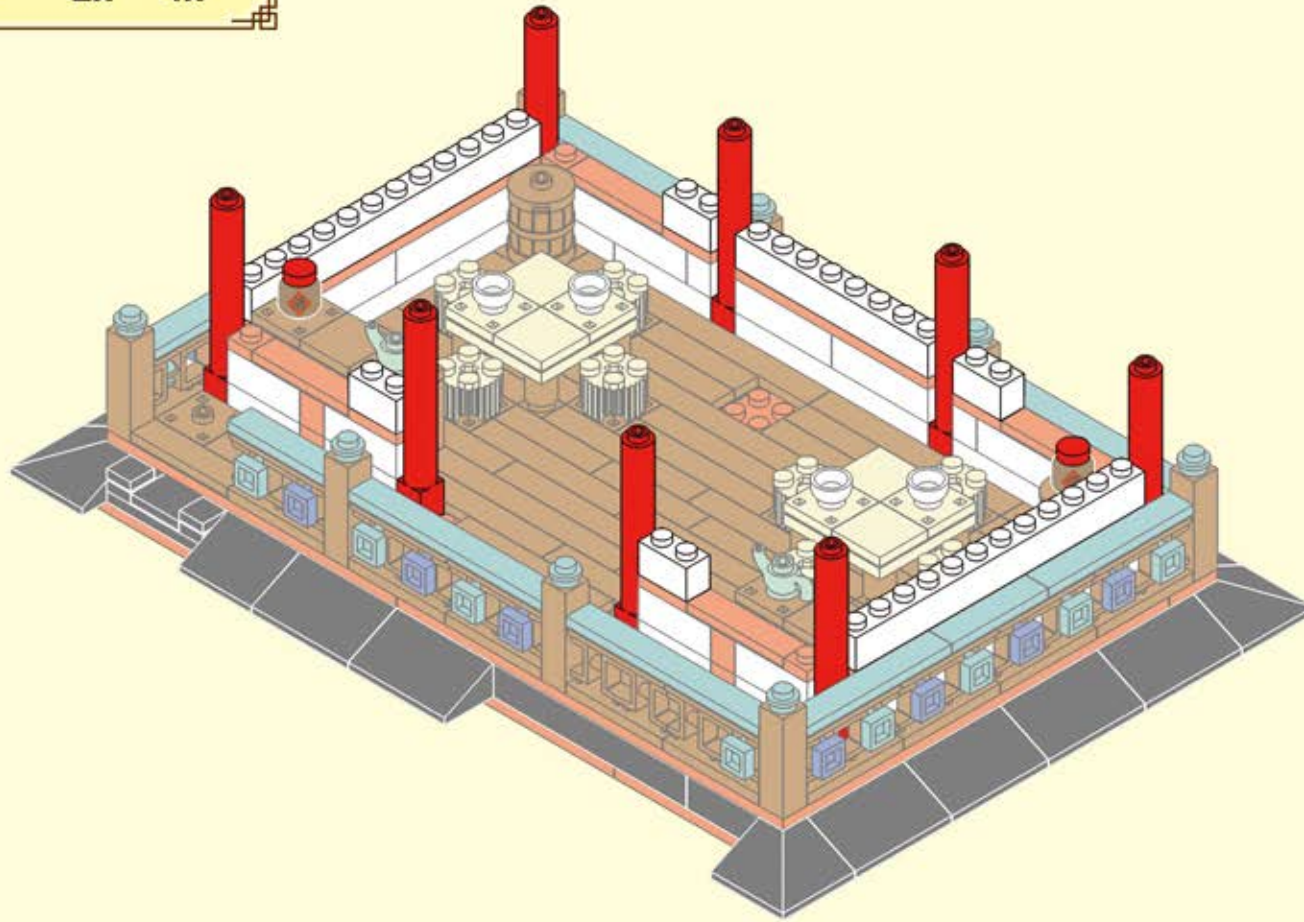

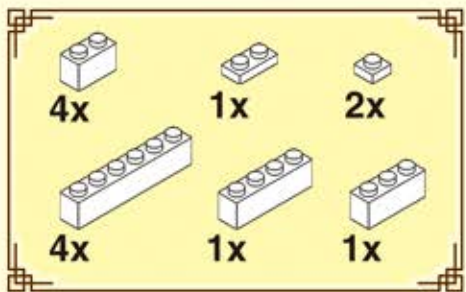

4-23

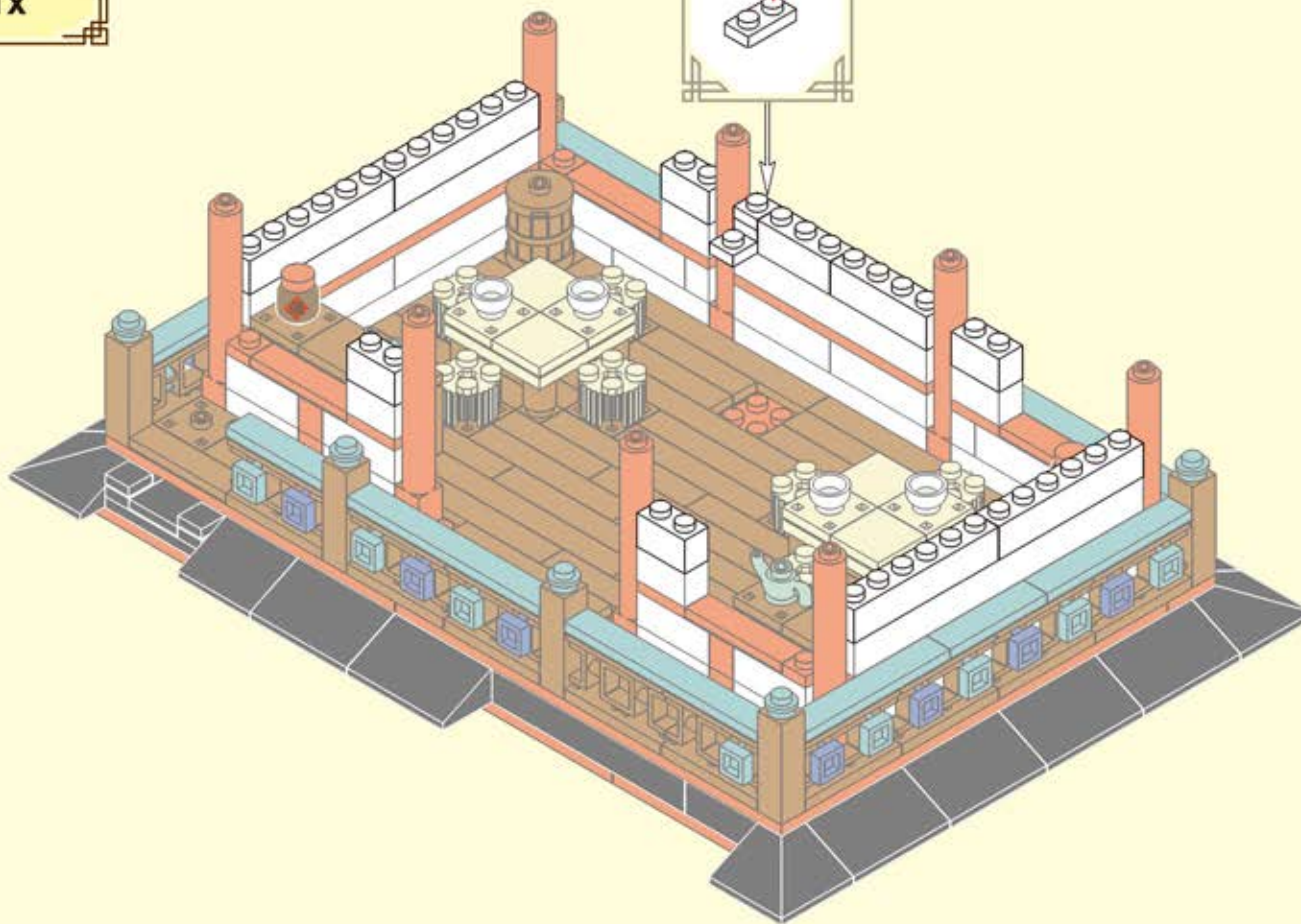
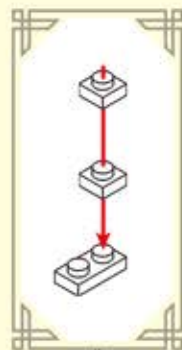

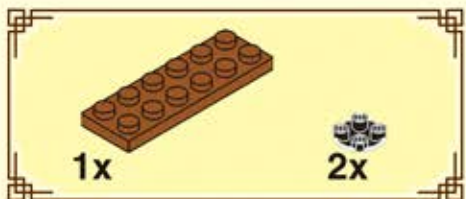

4-24

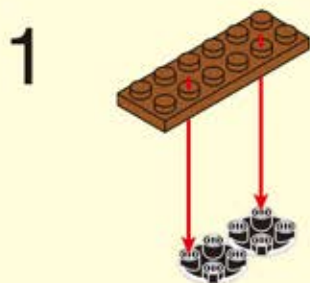

4-25

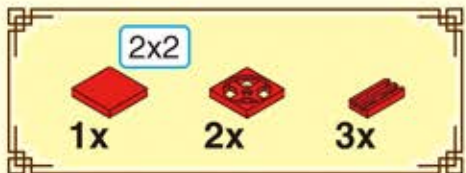

4-26

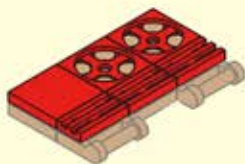

4-27

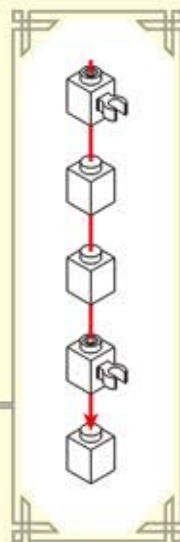
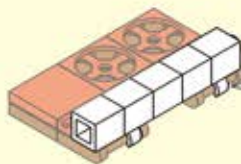

4-28

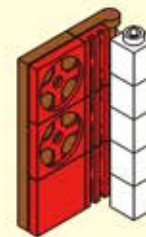

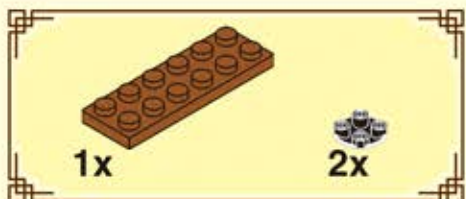

4-29

1

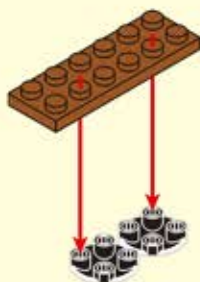

2



4-30

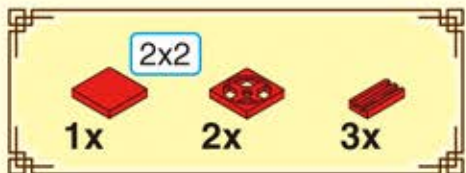

4-31

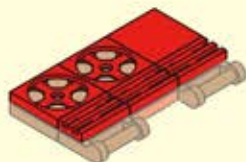

4-32

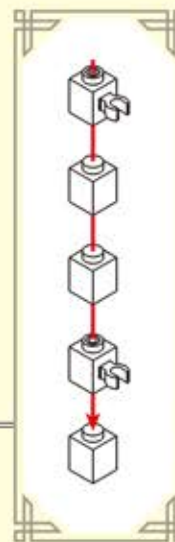
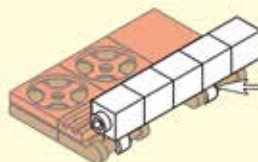

4-33



4-34

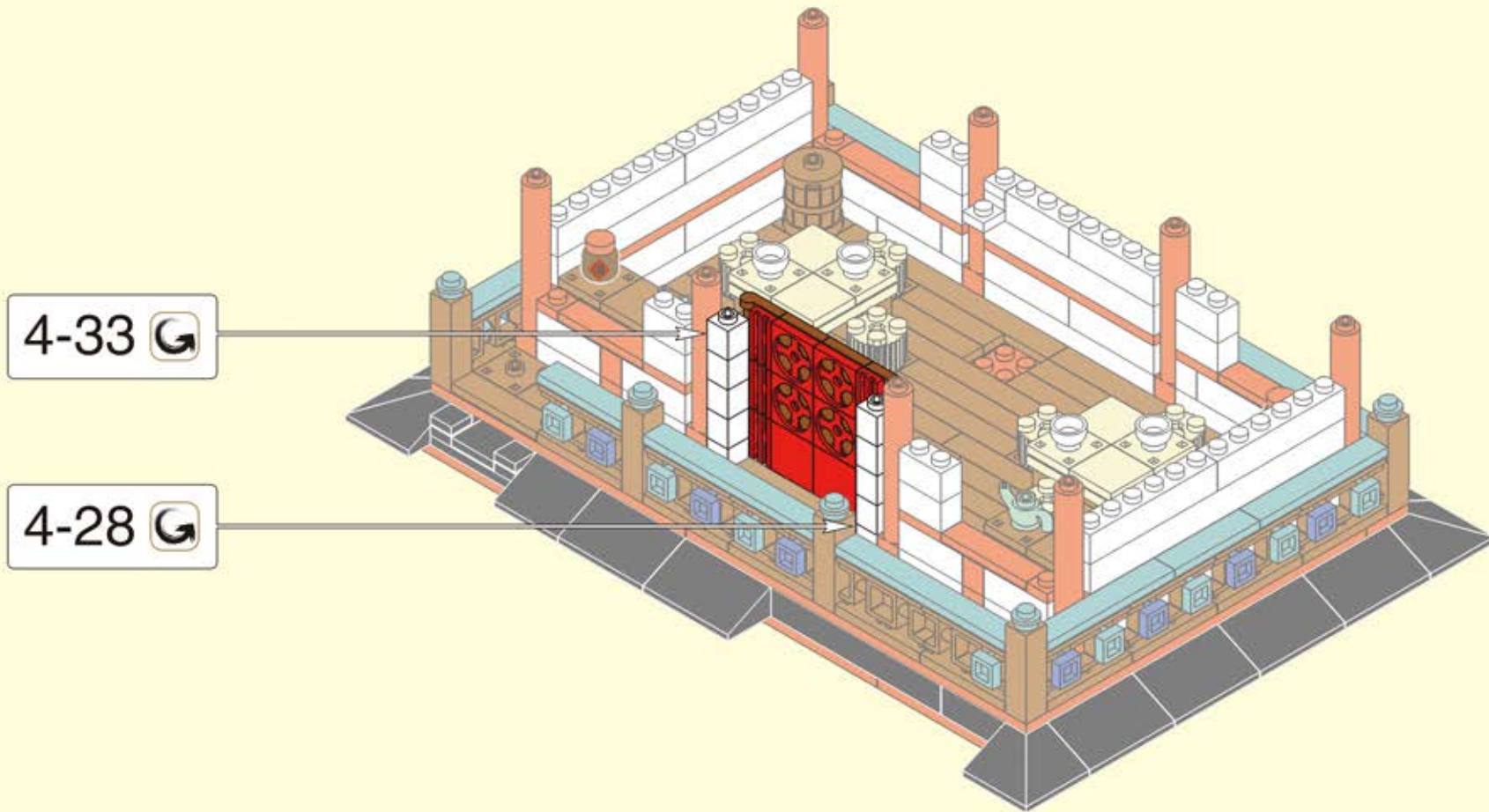

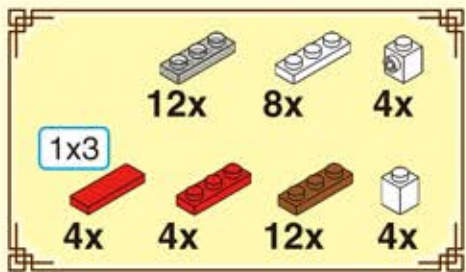

4-35

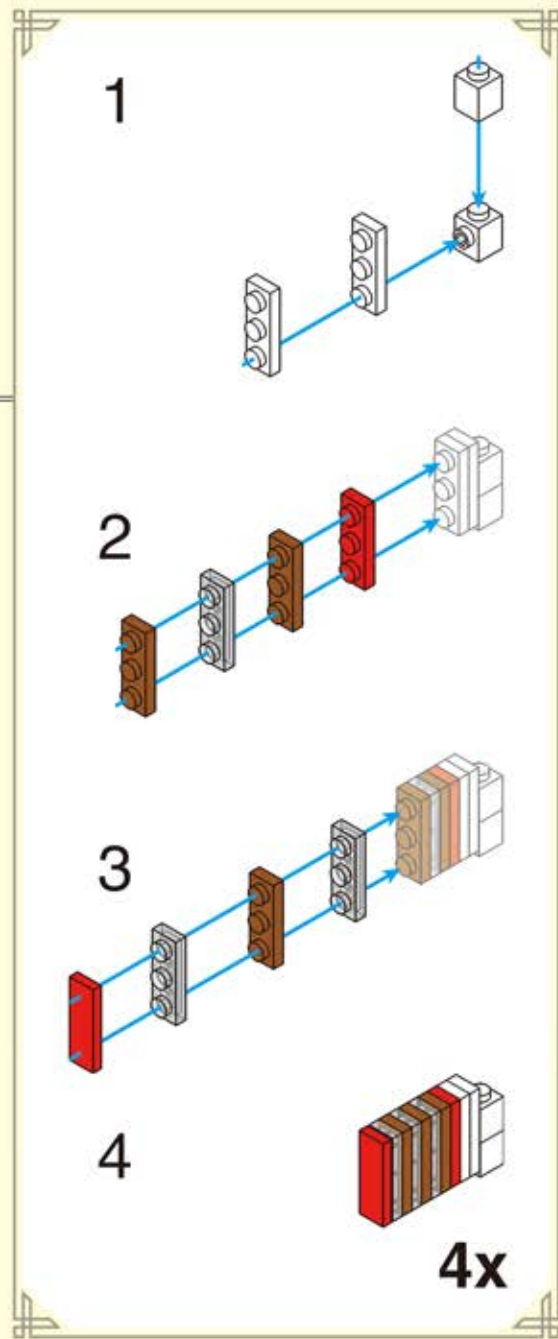
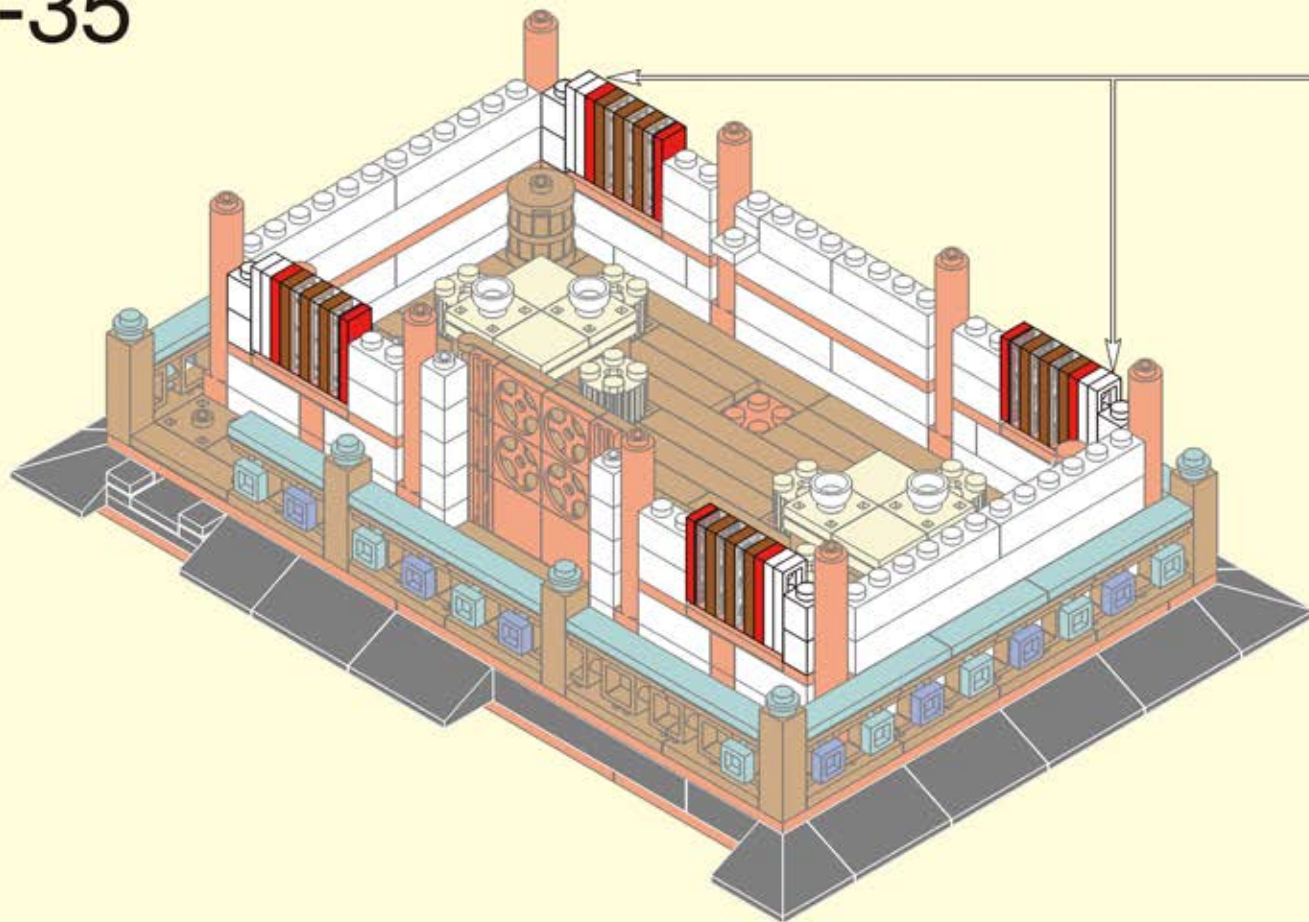

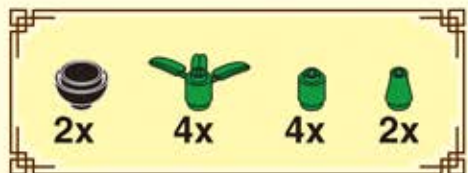

4-36

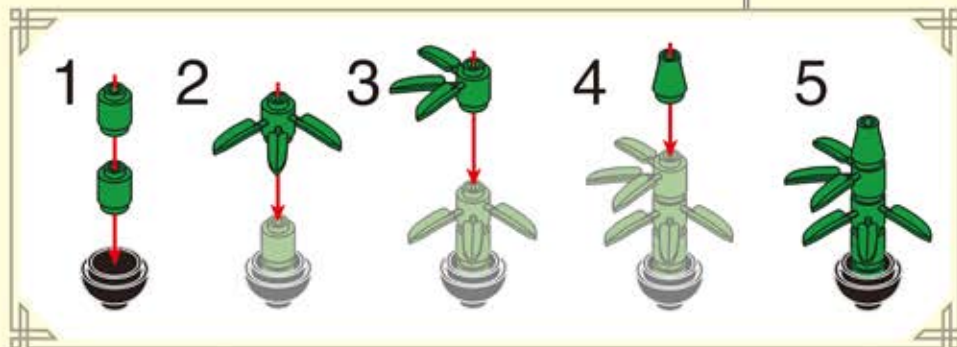
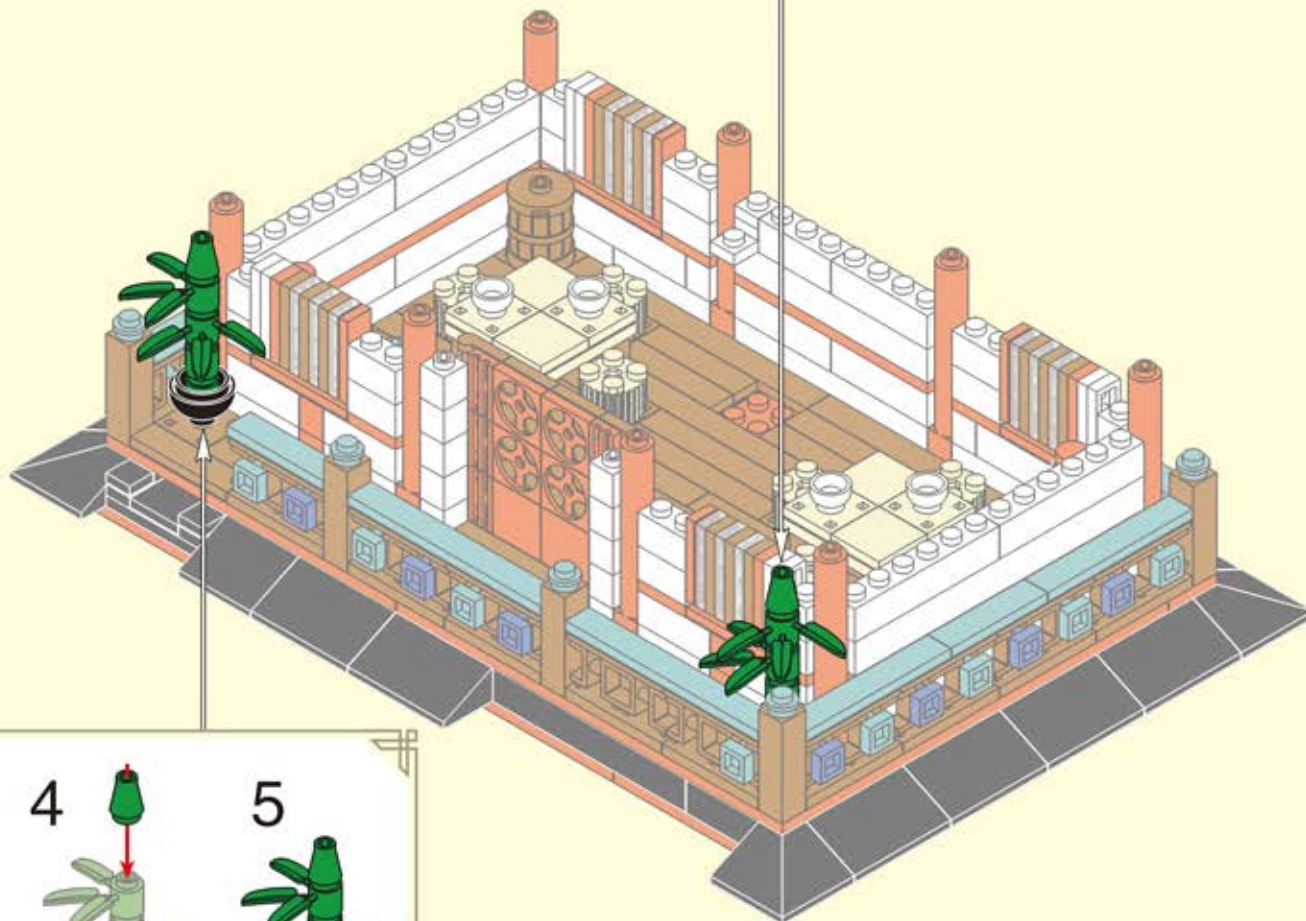
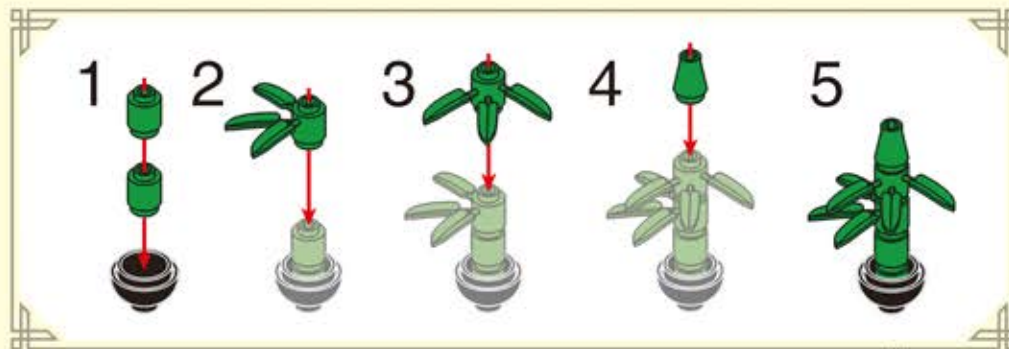

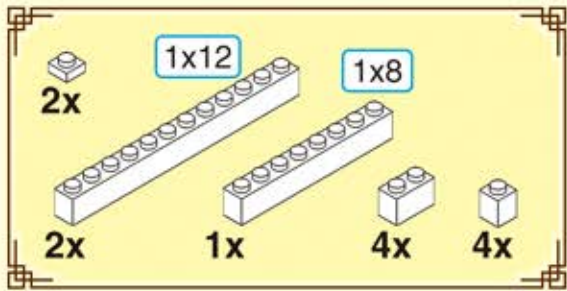

4-37

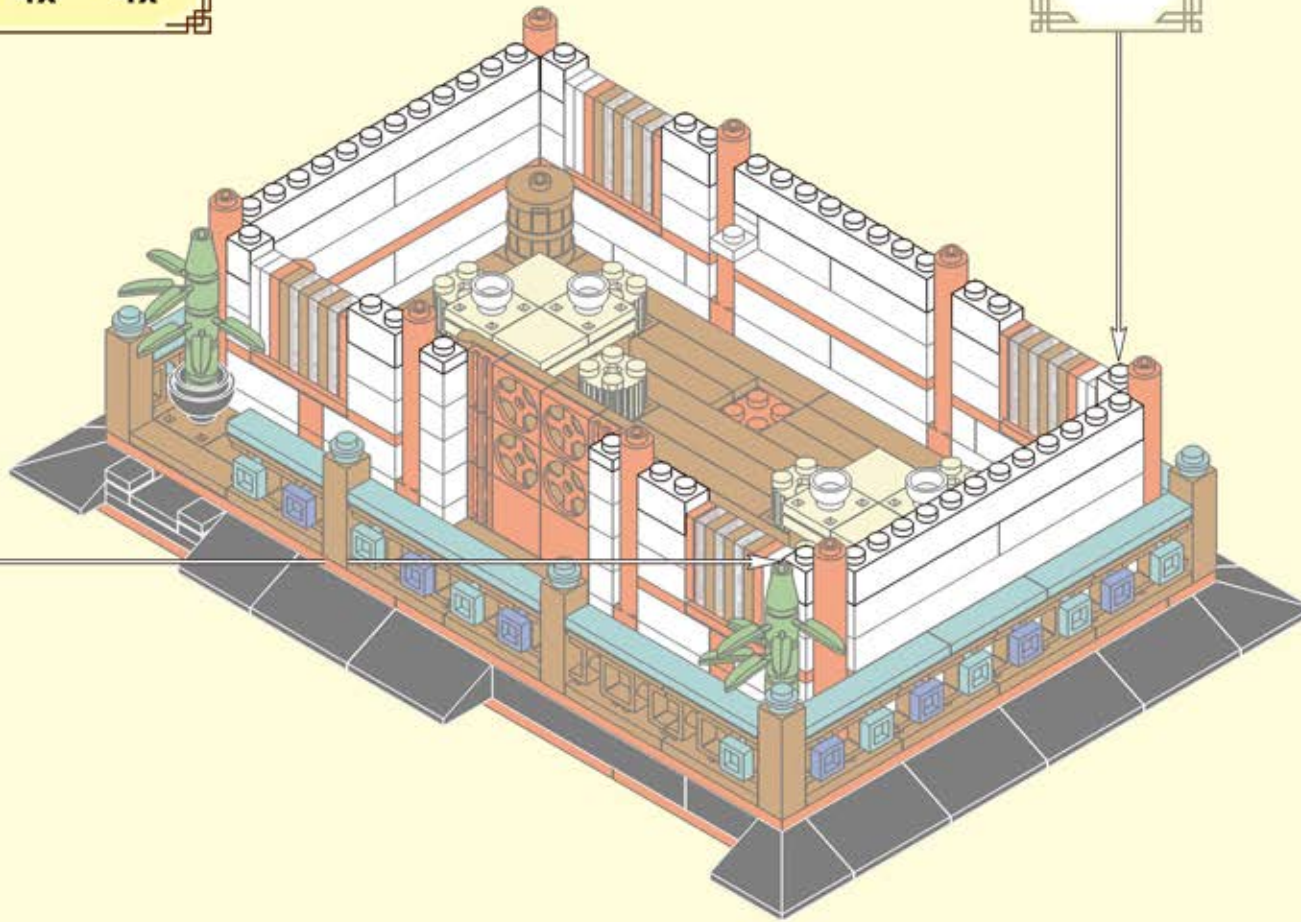
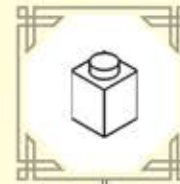

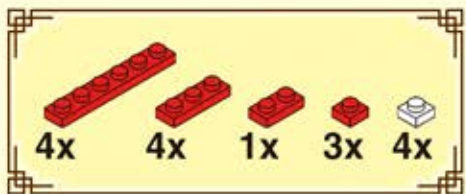

4-38

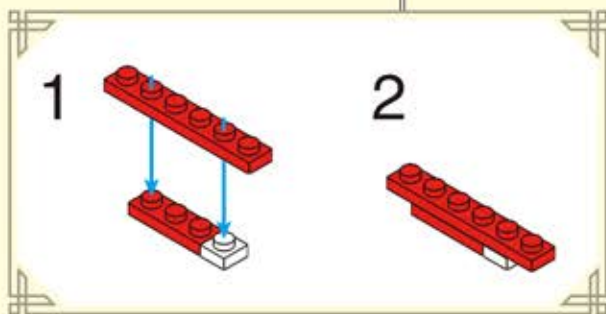
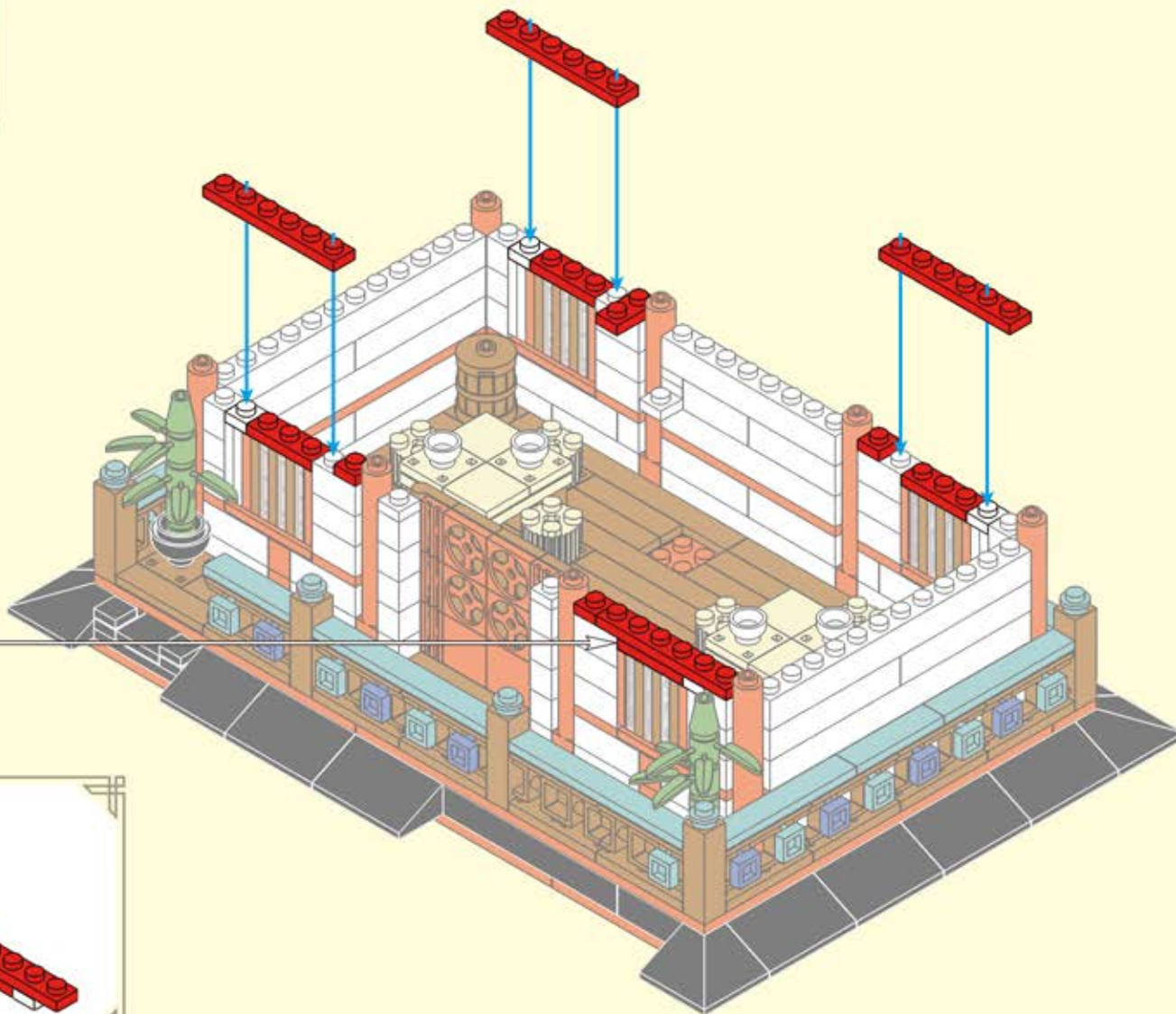

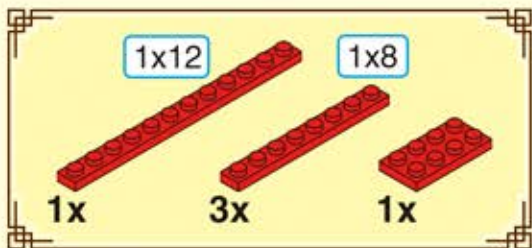

4-39

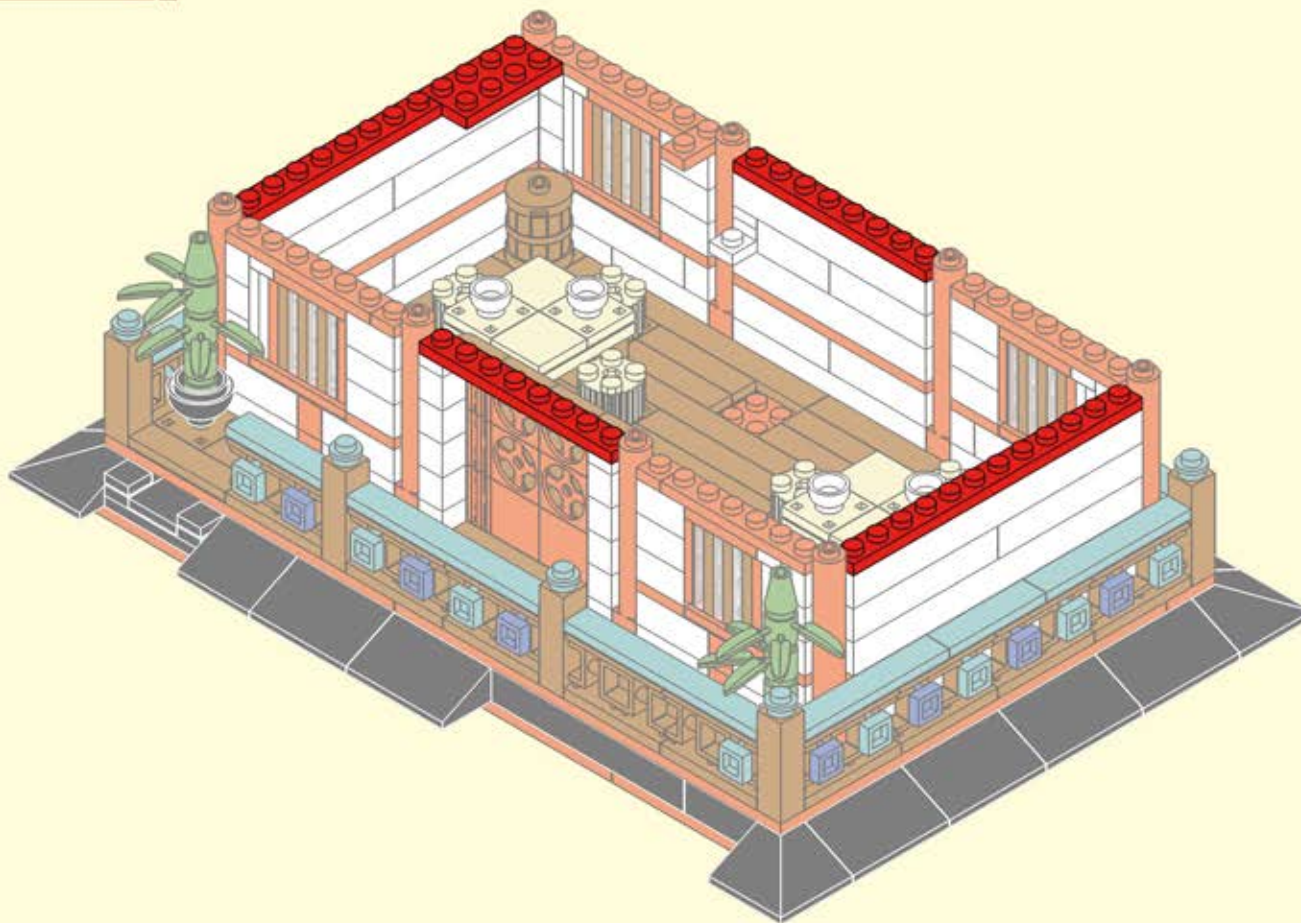

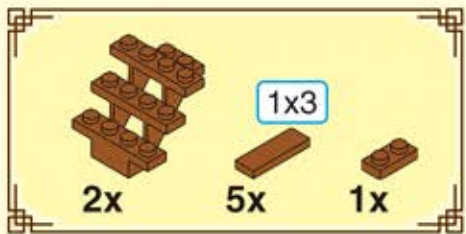

4-40

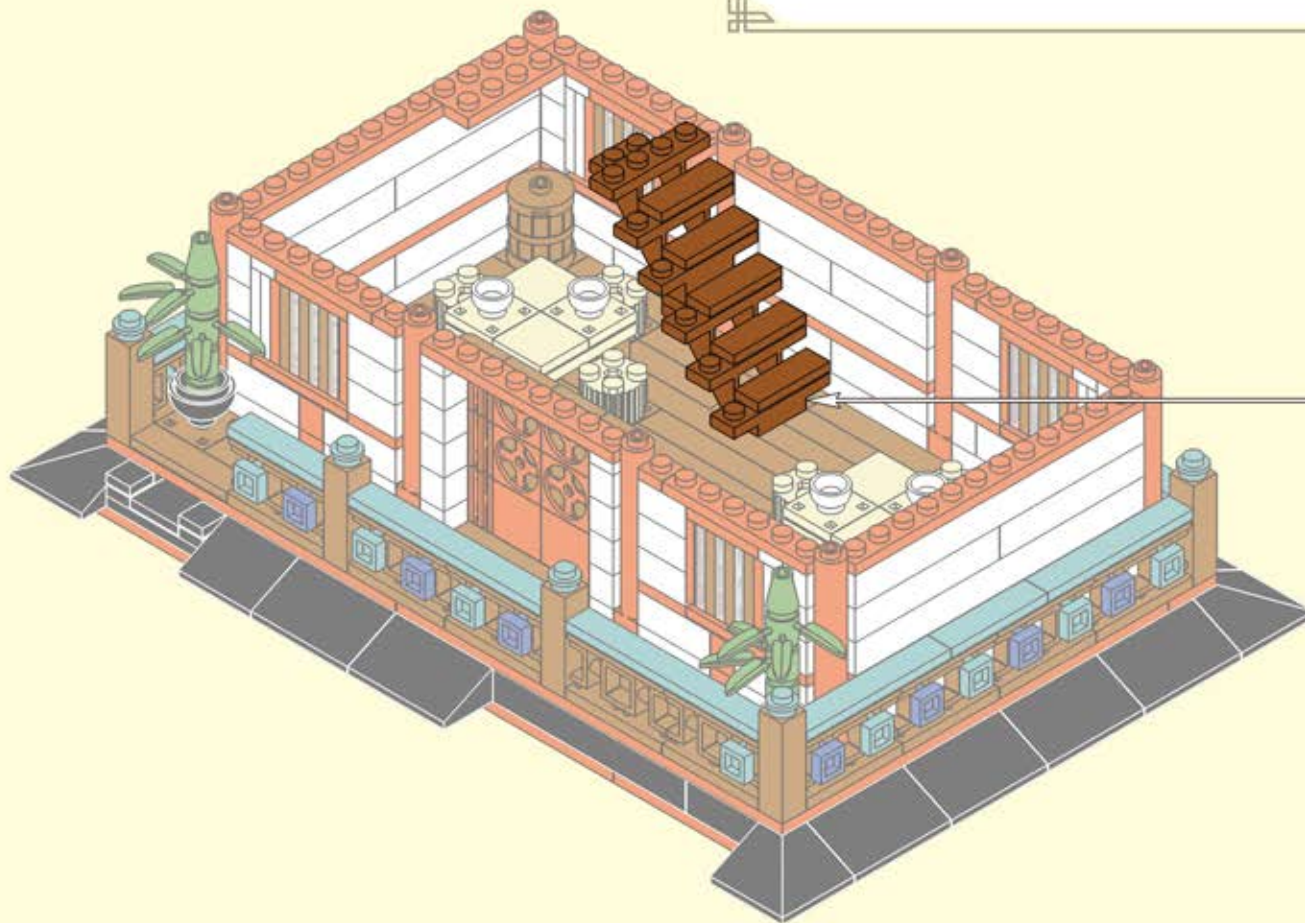
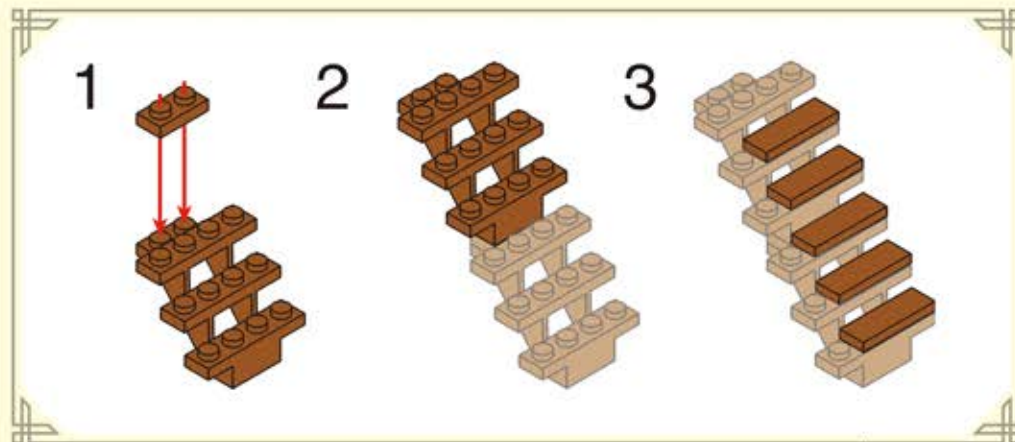

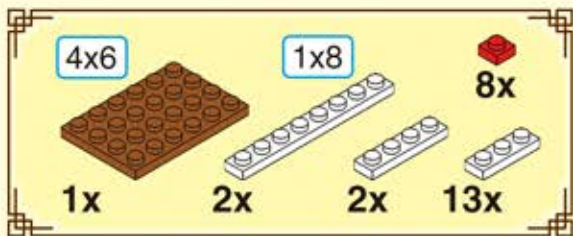

4-41

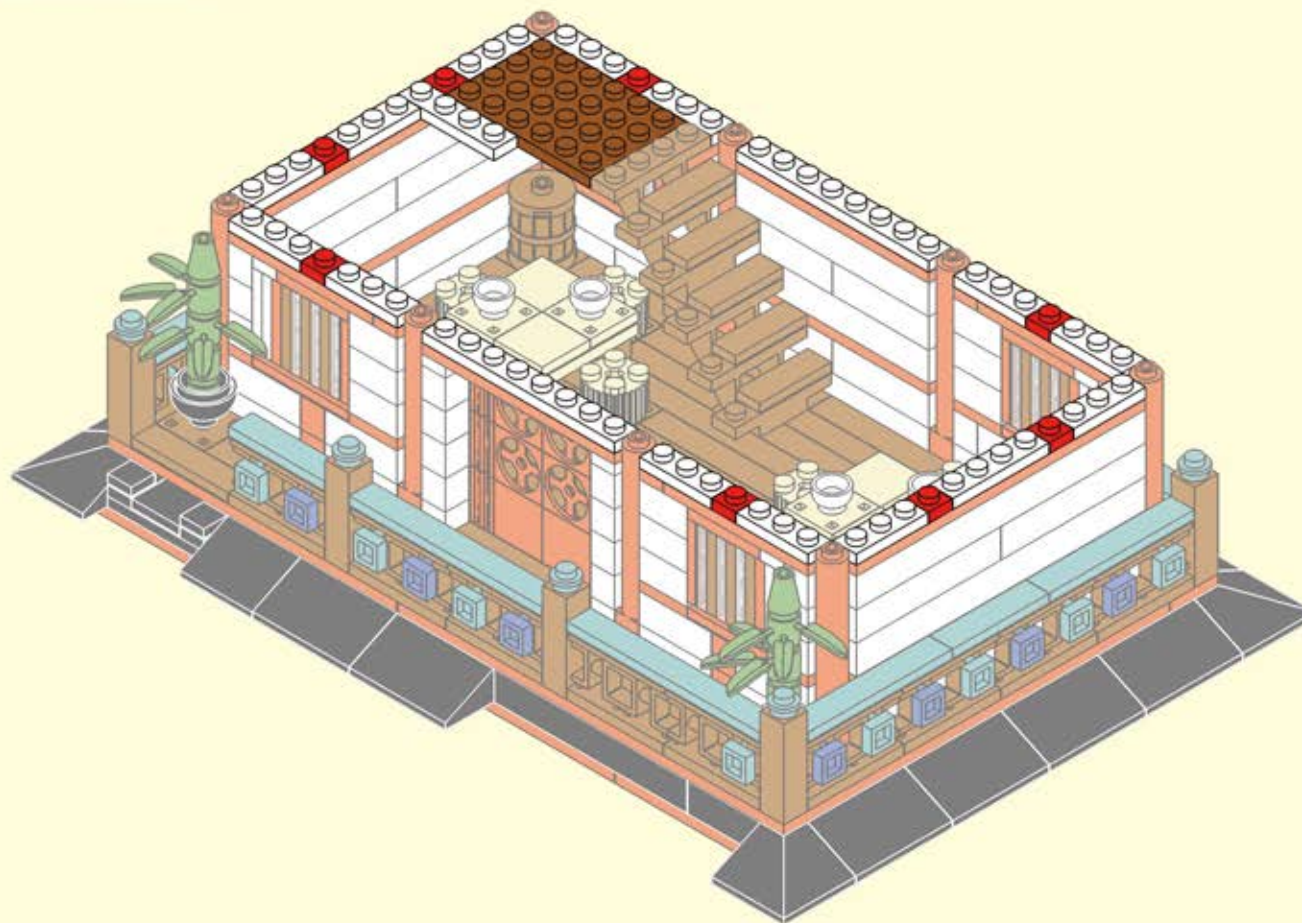

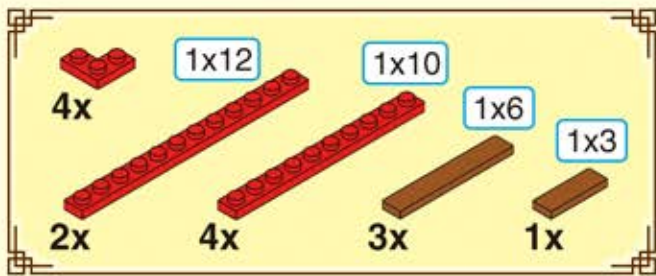

4-42





4-43

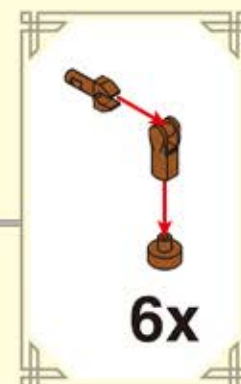
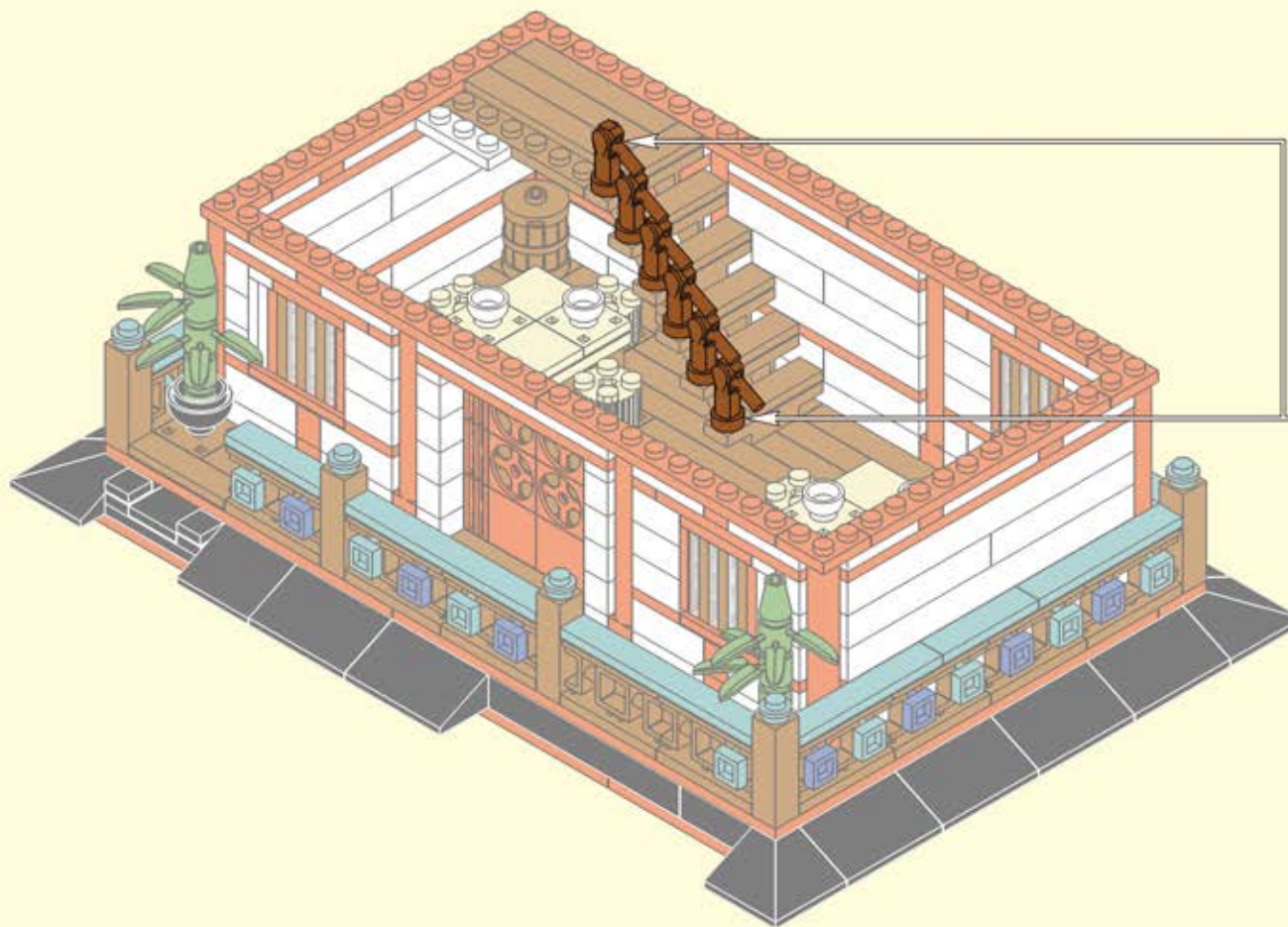

1x	14x	13x	20x

4-44

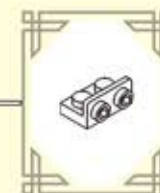
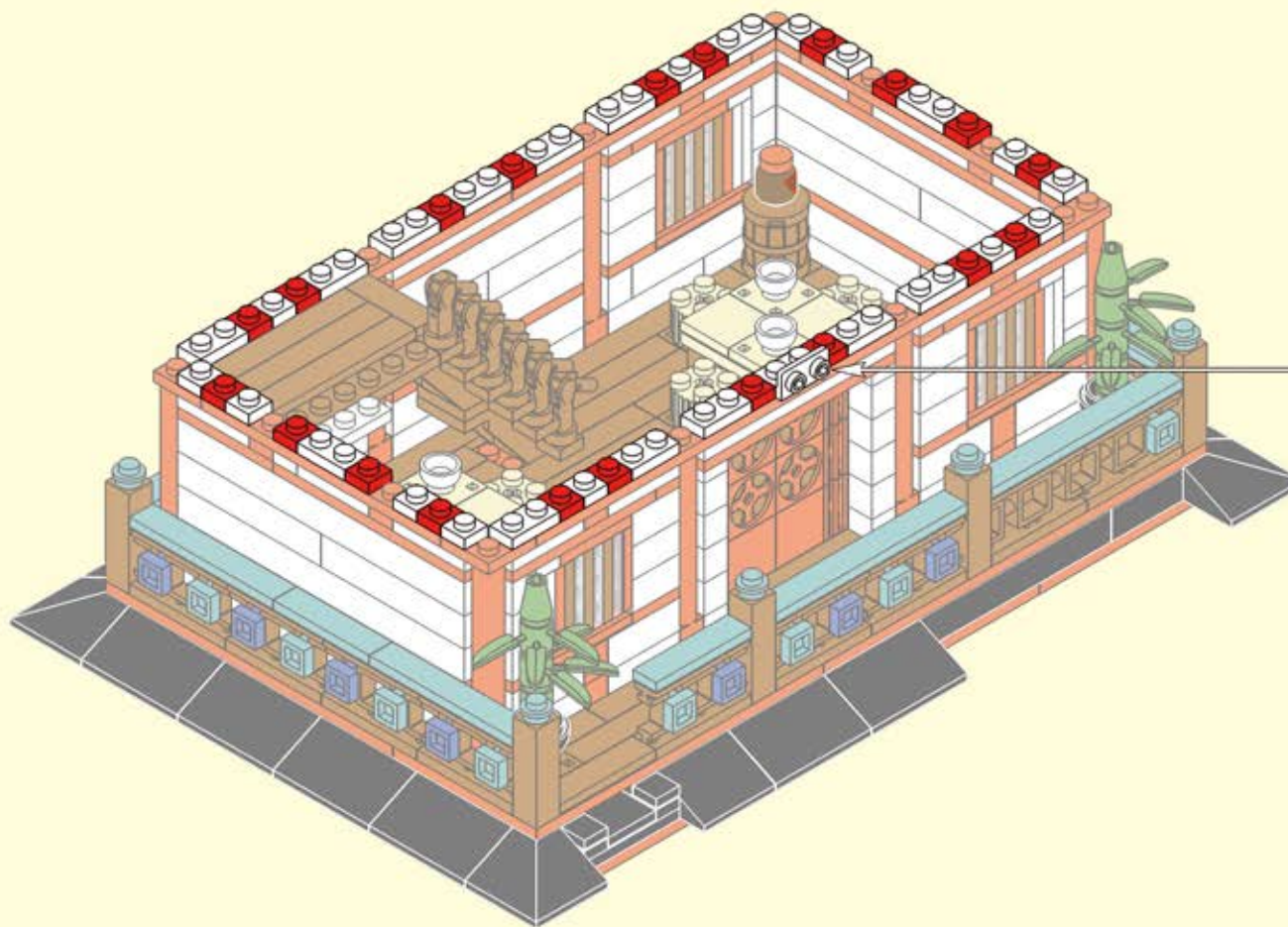



4-45

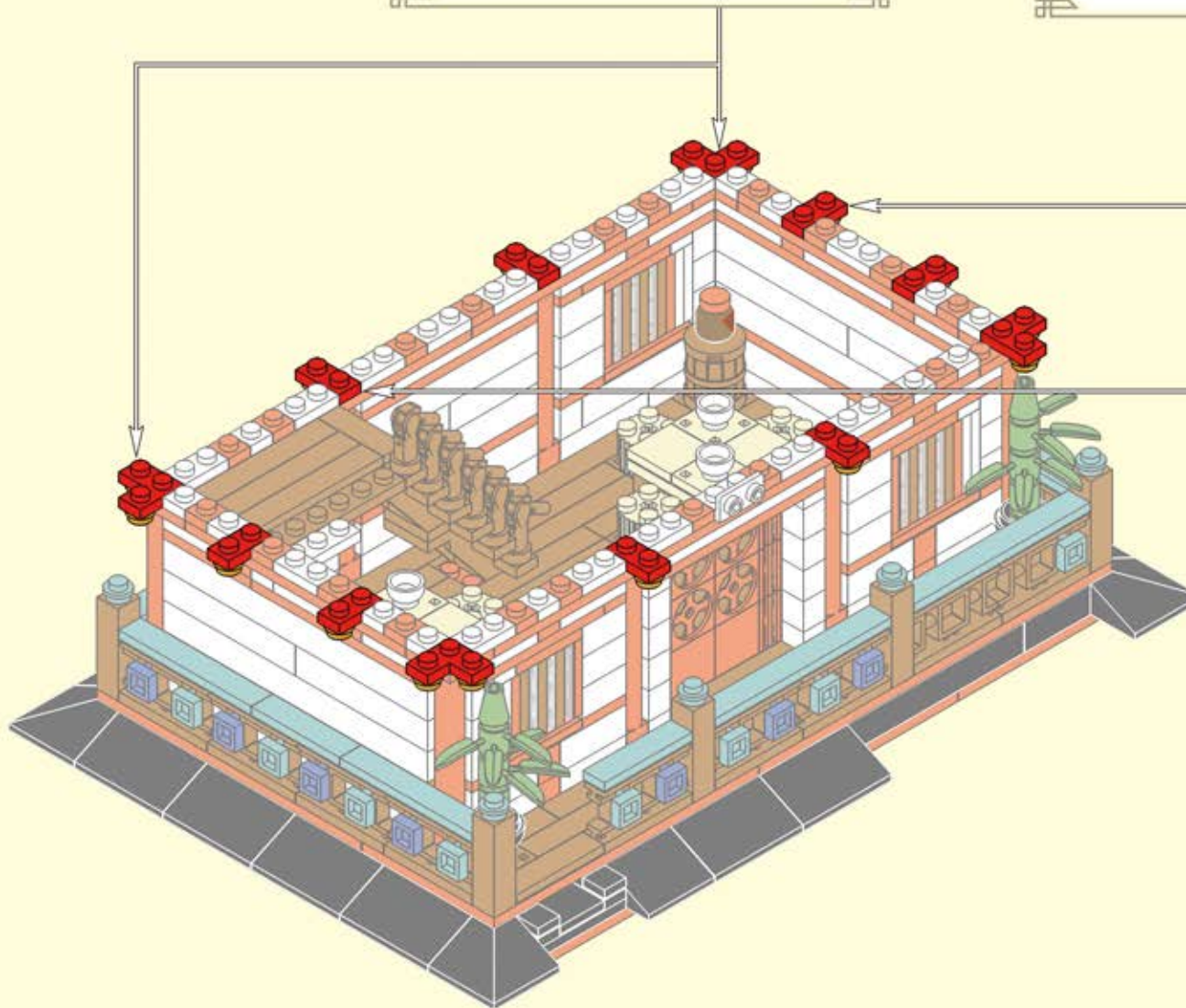
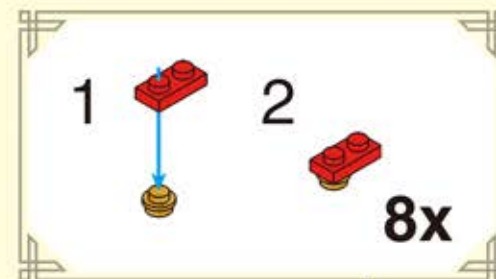
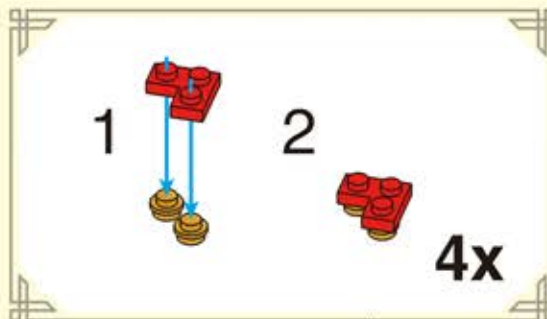

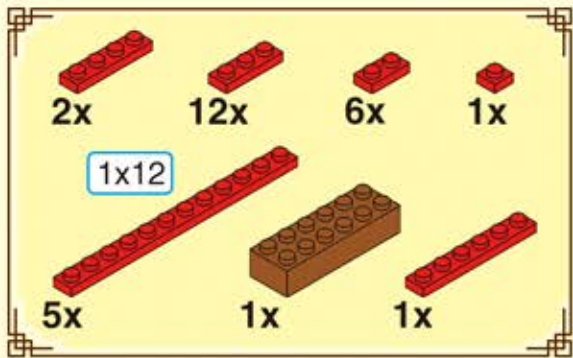

4-46

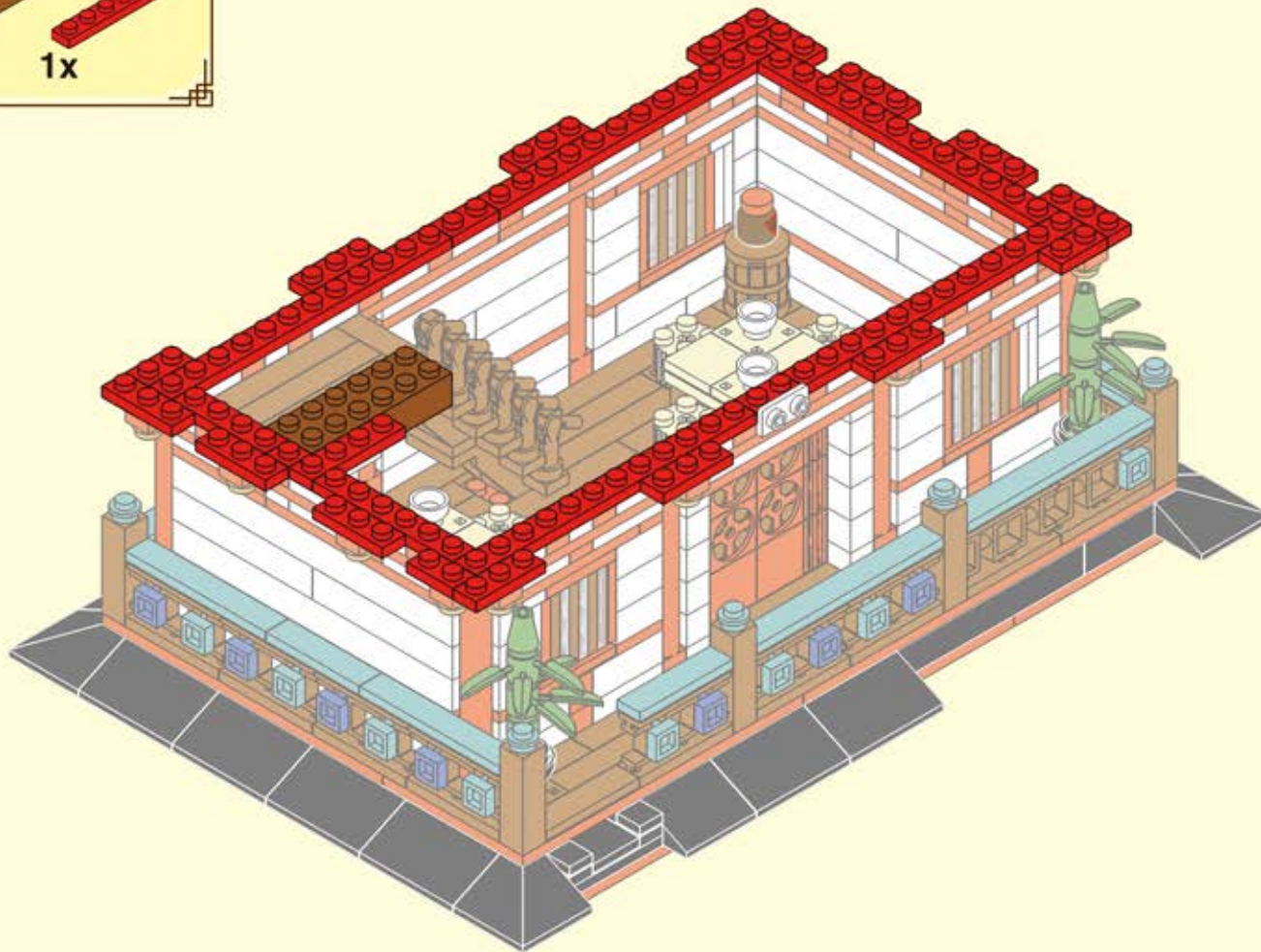

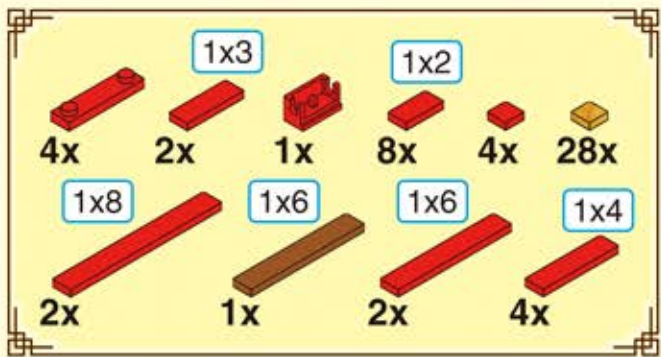

4-47

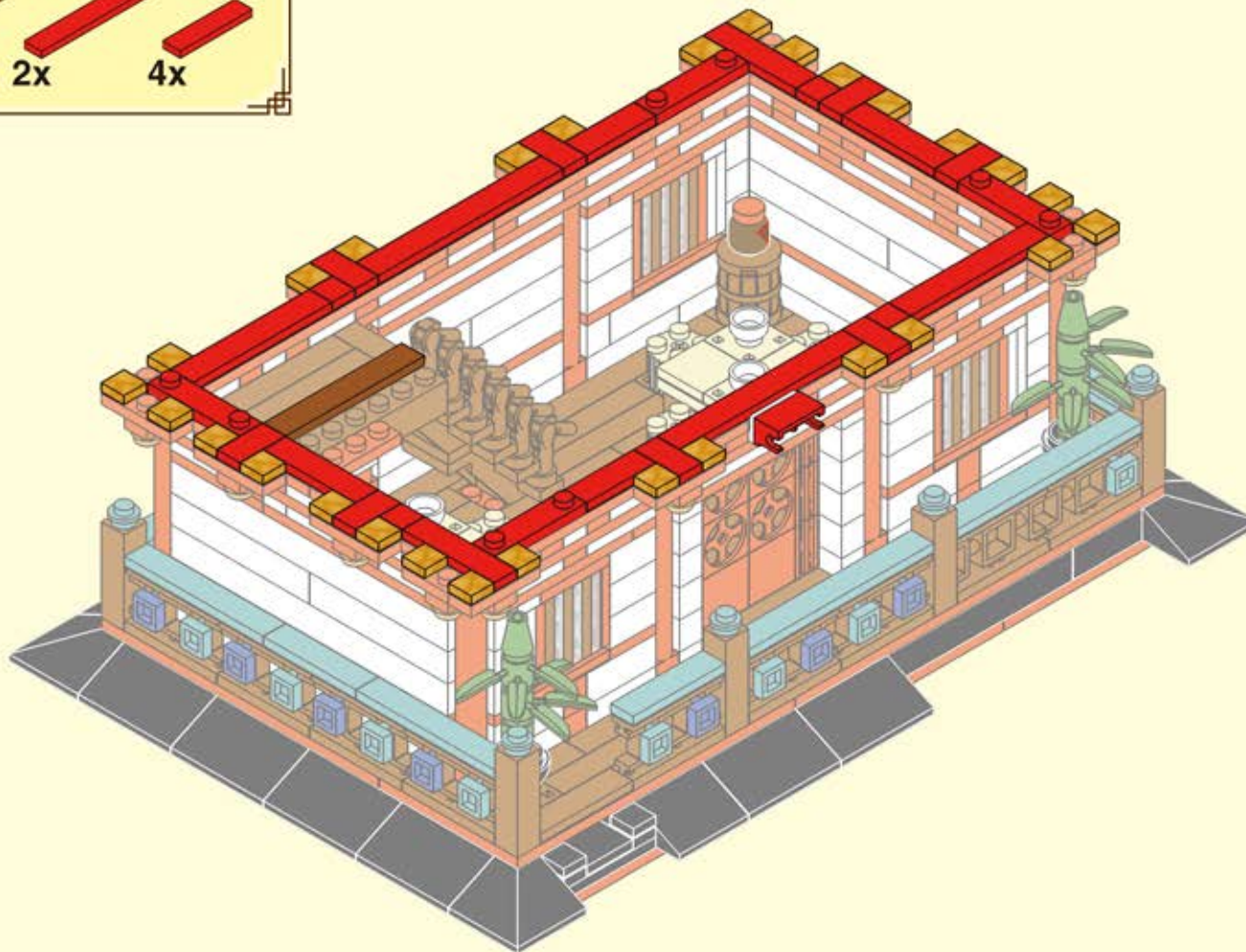

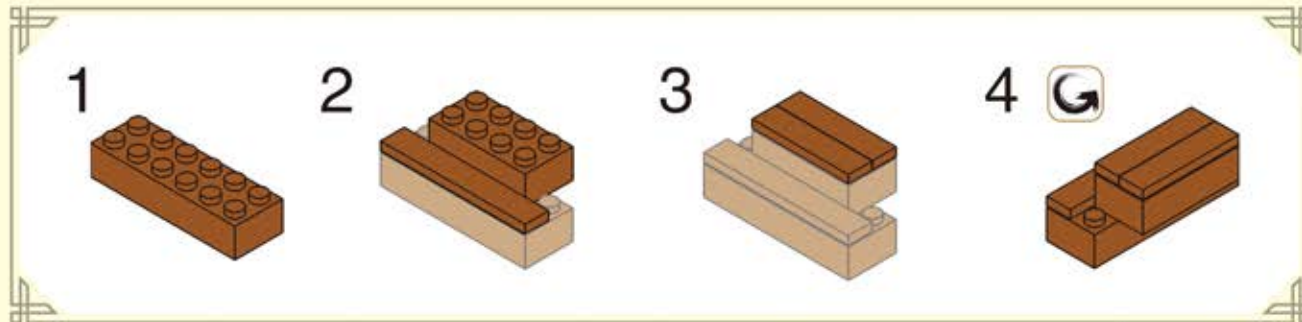
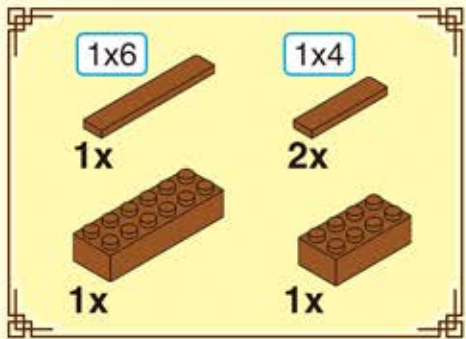

4-48

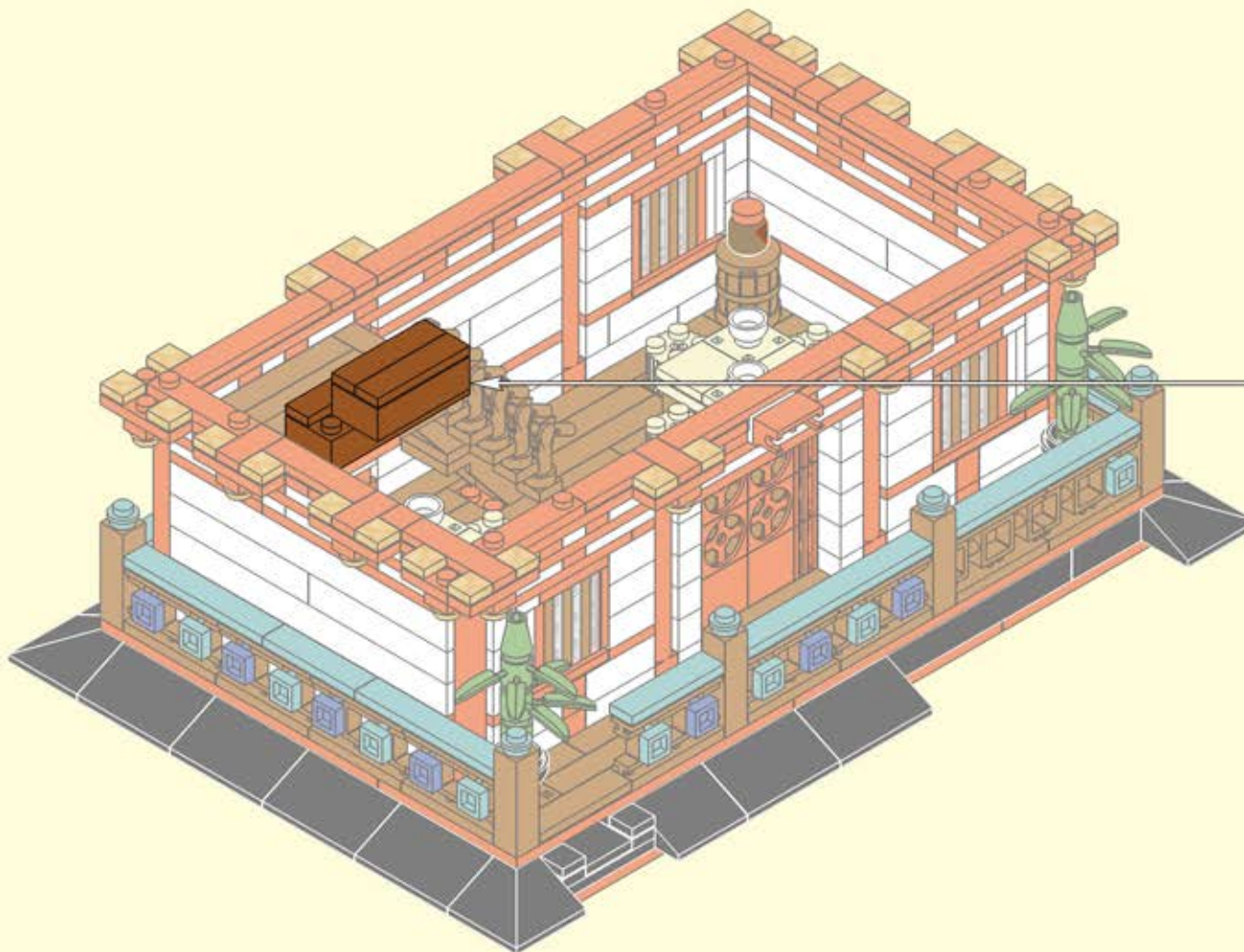

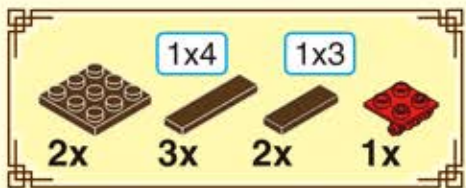

4-49

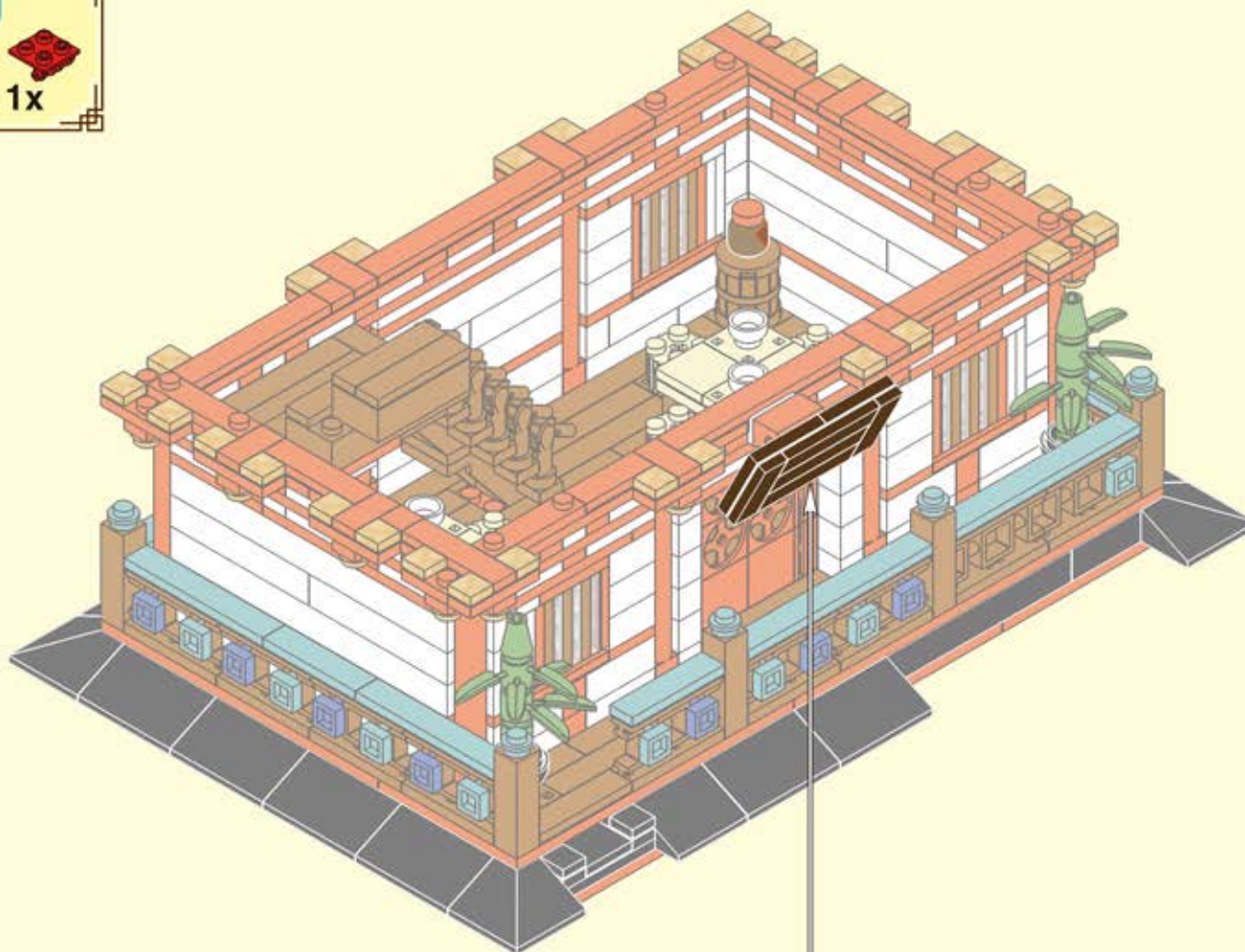

4-50

4-49 

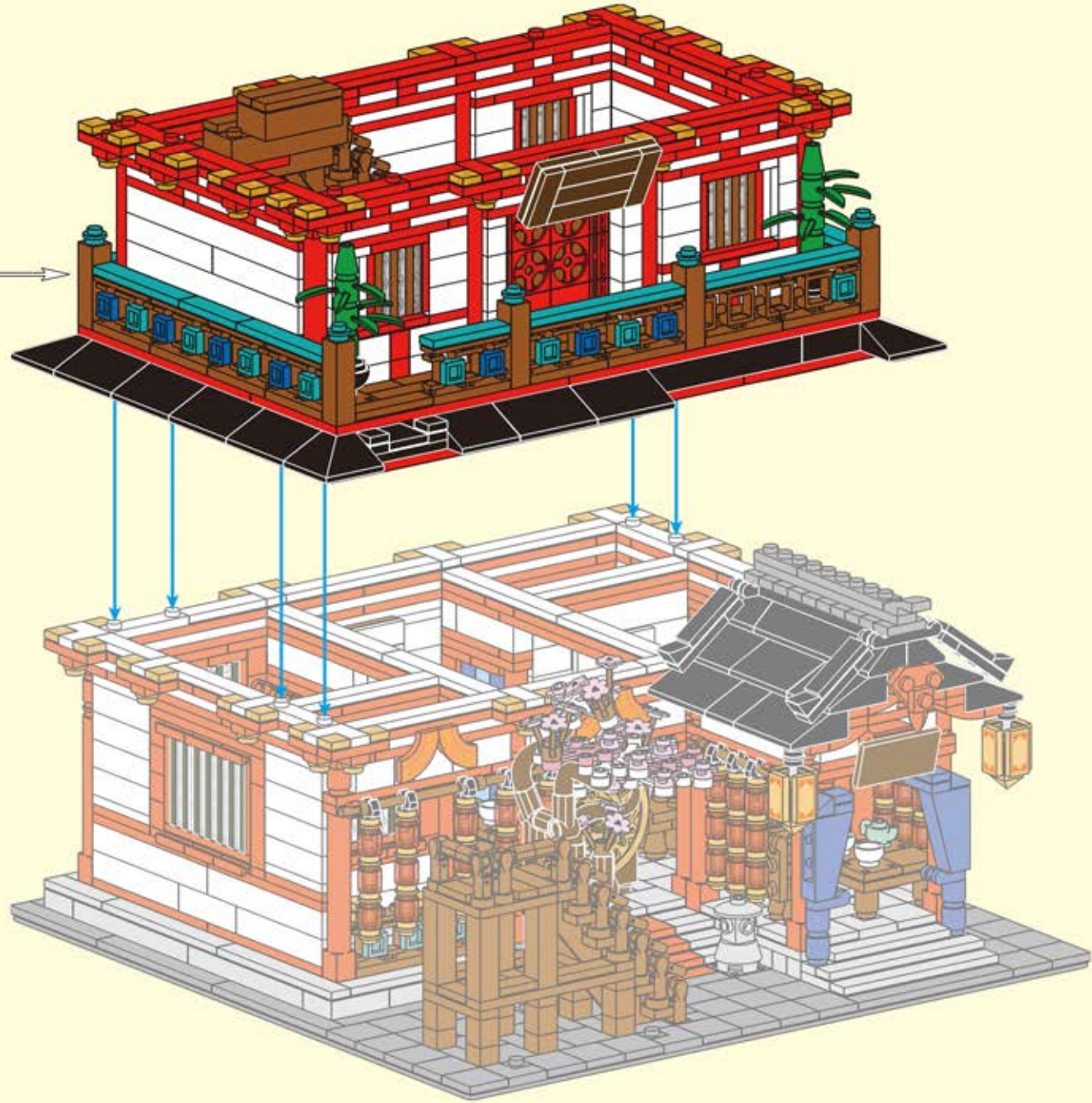

4-51

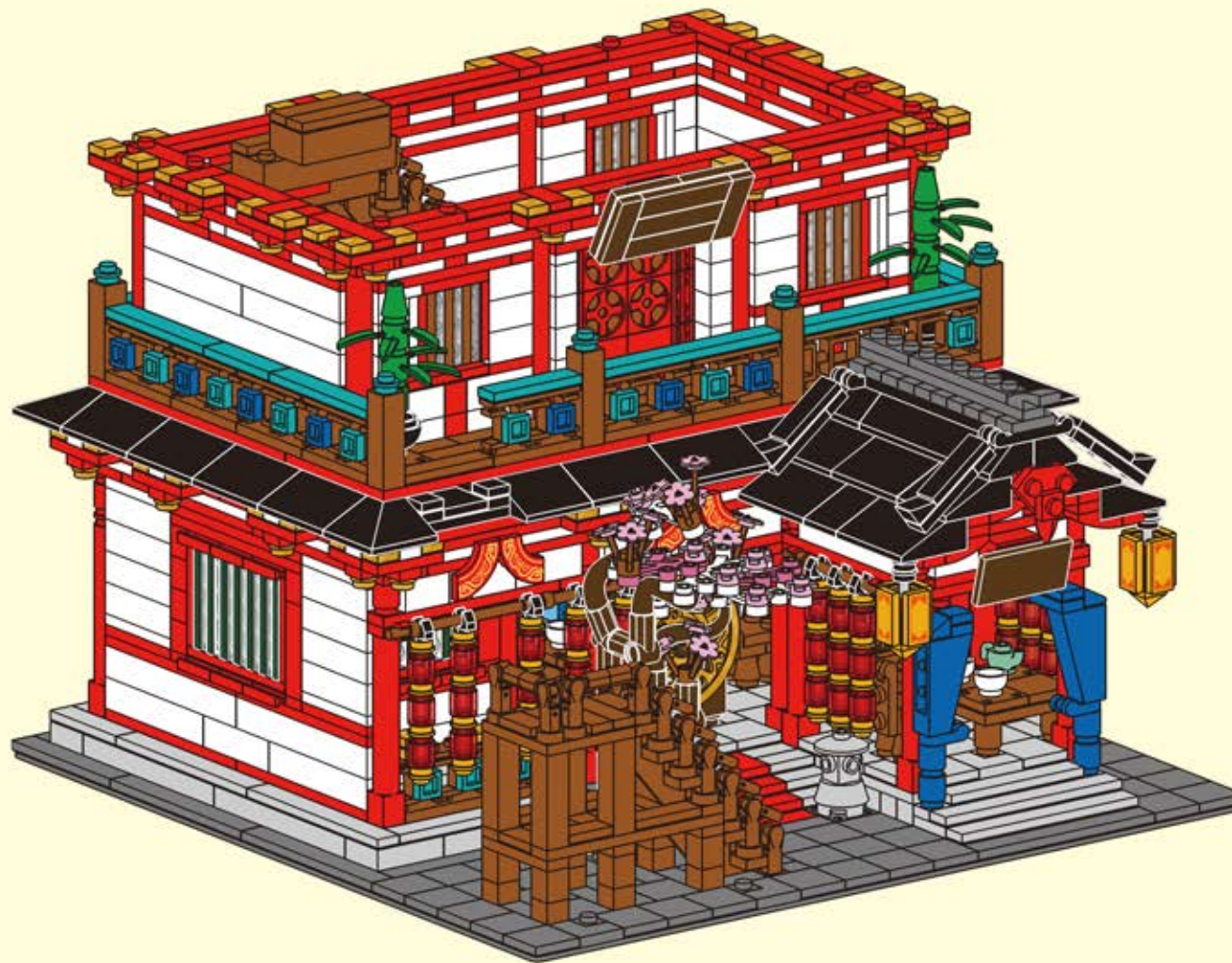



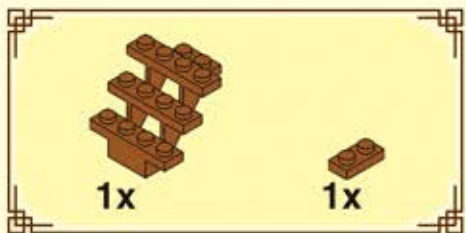

5-1

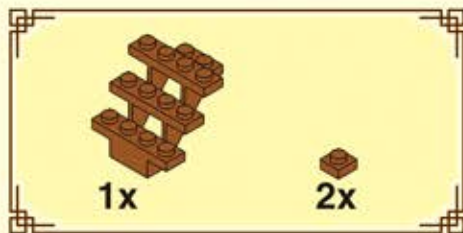
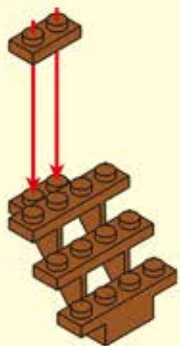

5-2

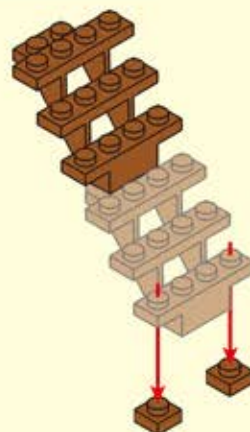

5-3

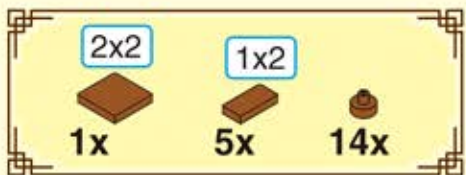
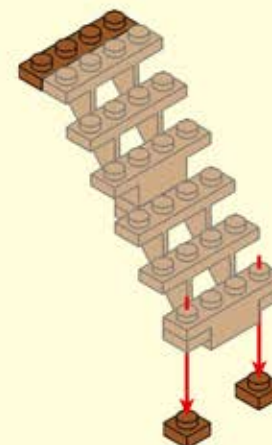

5-4

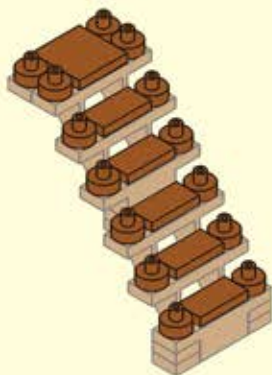

5-5

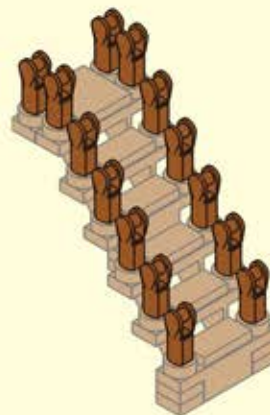

5-6

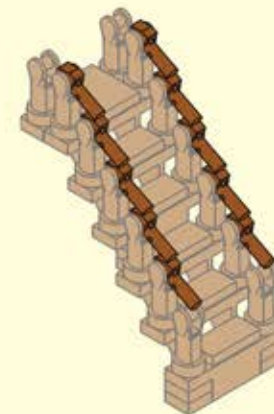

5-7

5-6



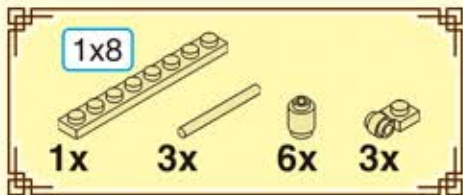

5-8

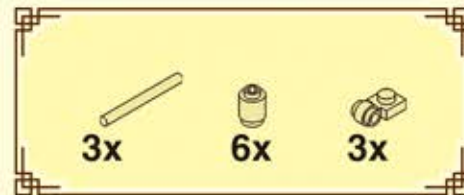
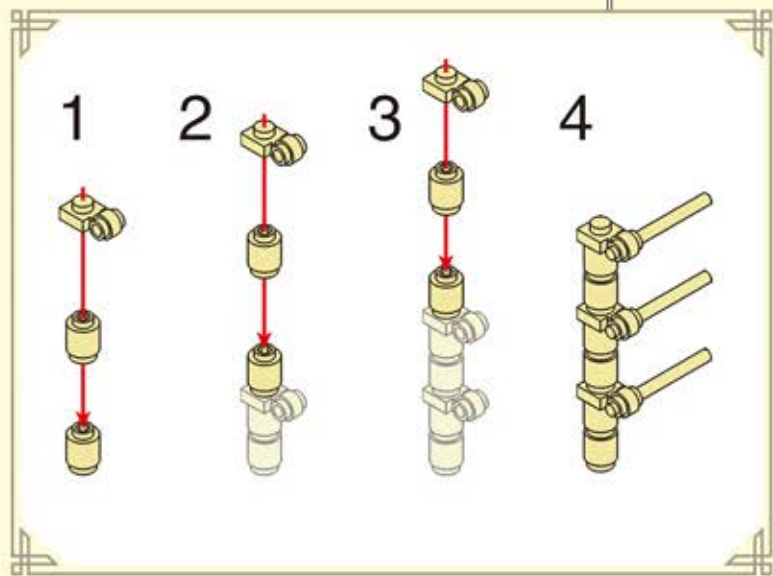
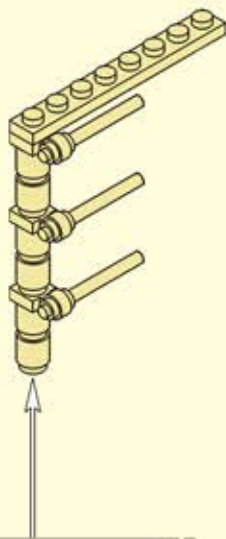

5-9

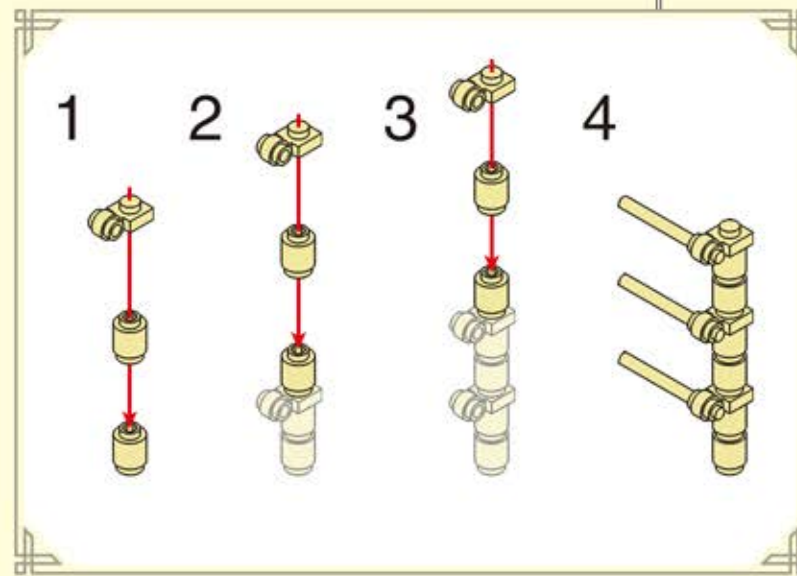
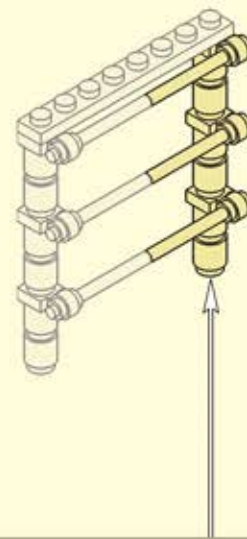



5-10

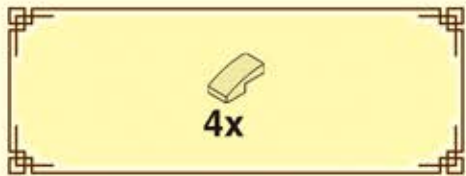
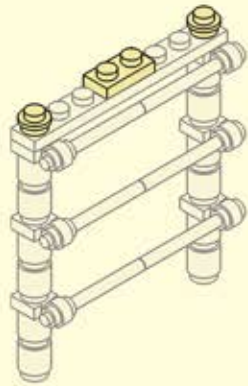

5-11

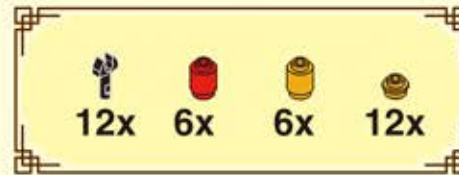
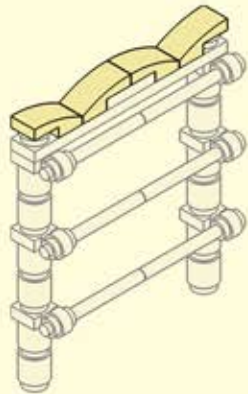

5-12

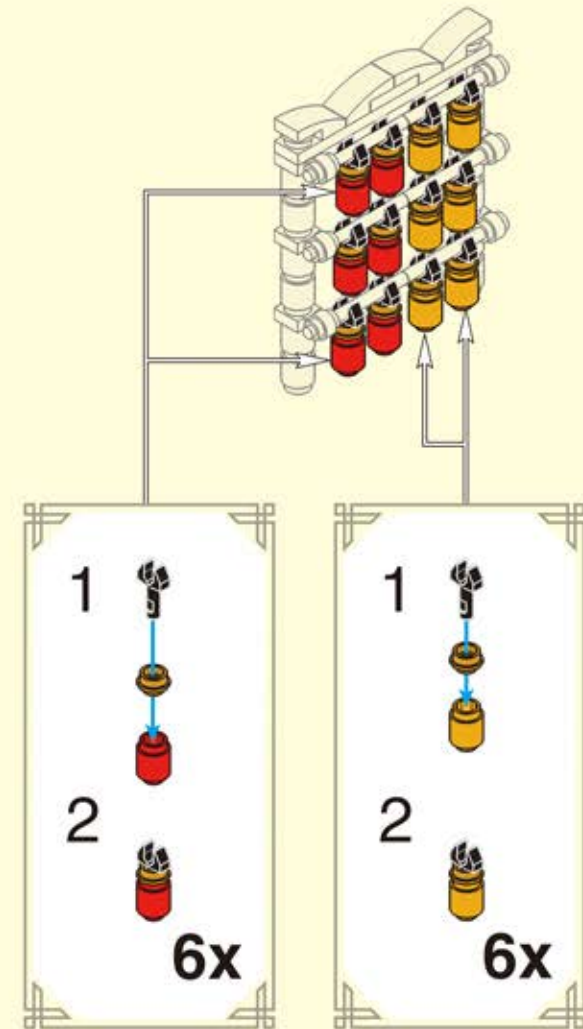

5-13



5-12

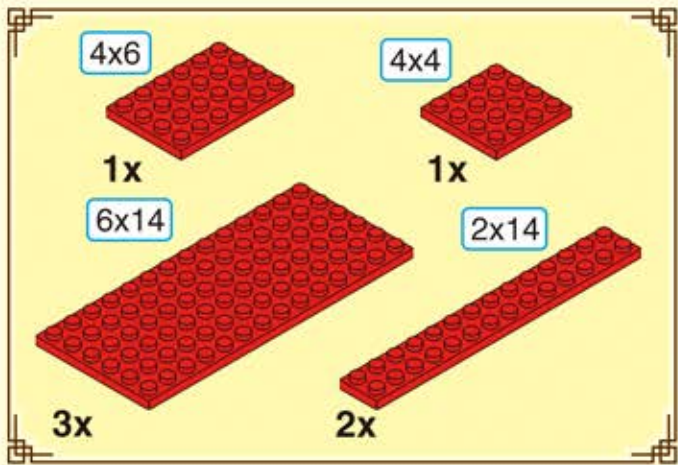

5-14

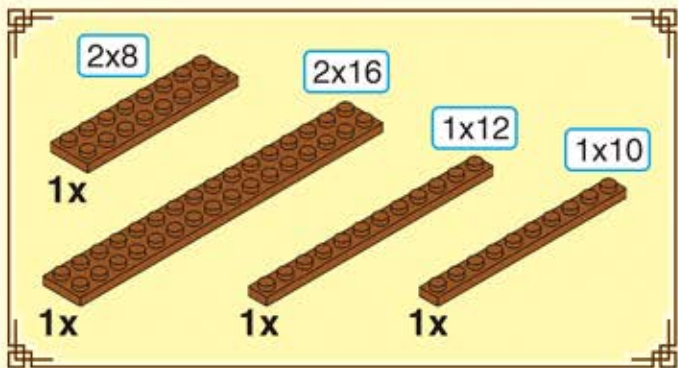
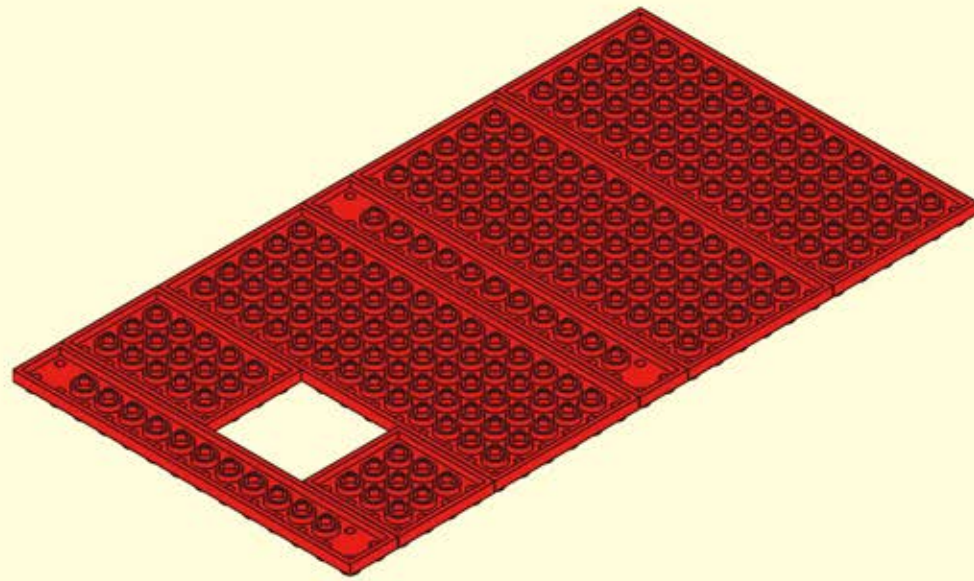

5-15

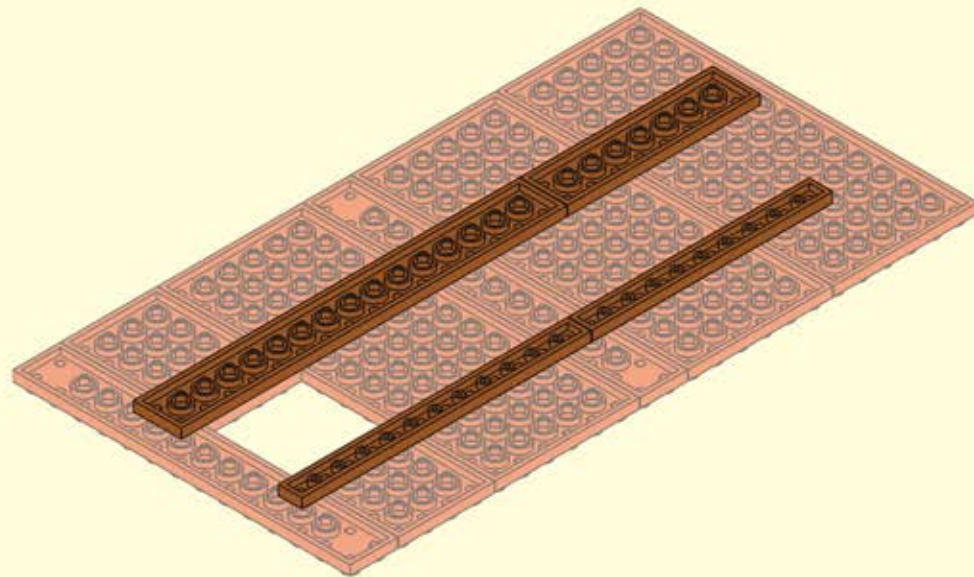

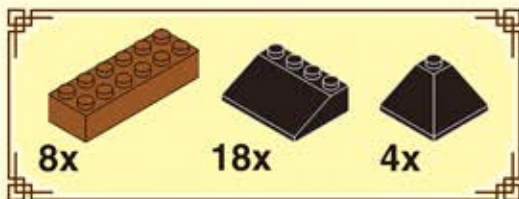

5-16

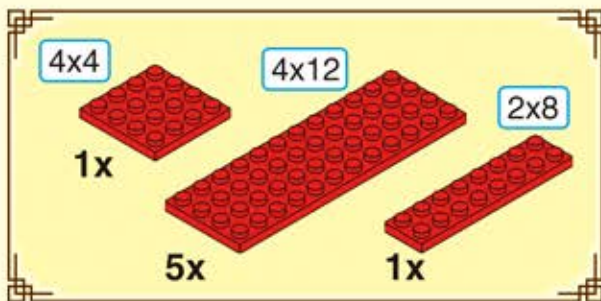
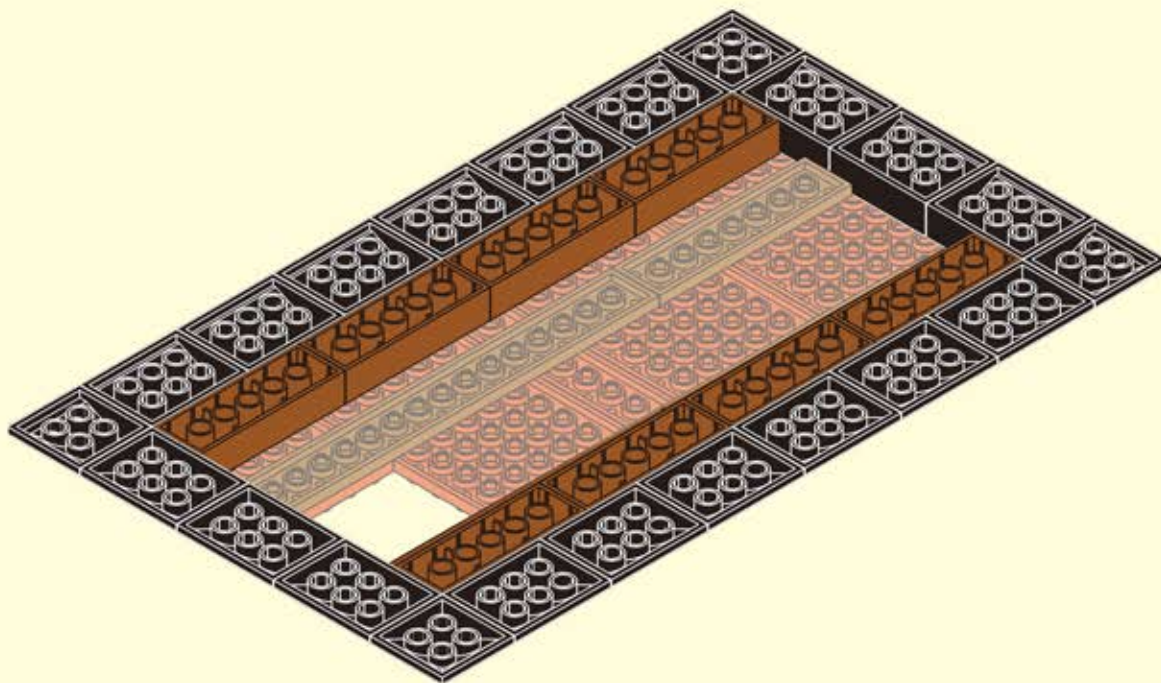

5-17

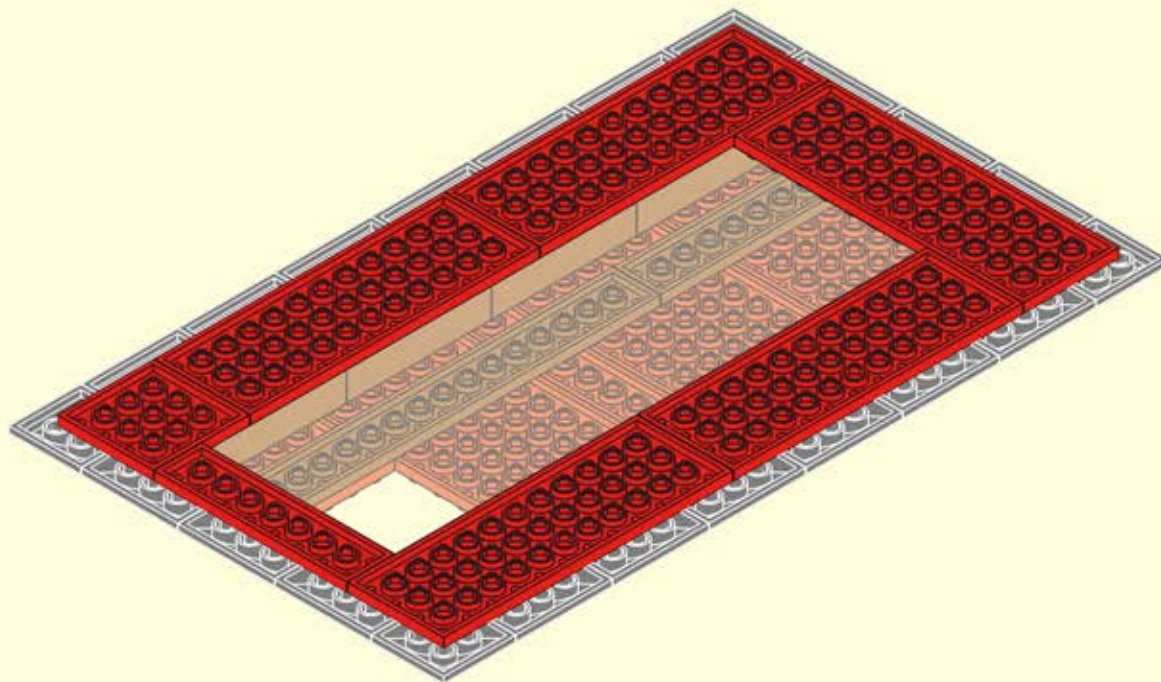

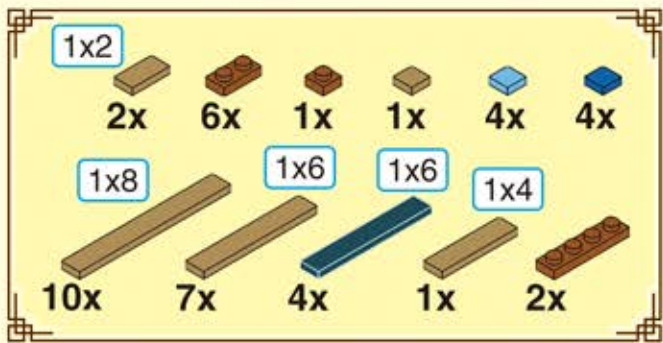

5-18

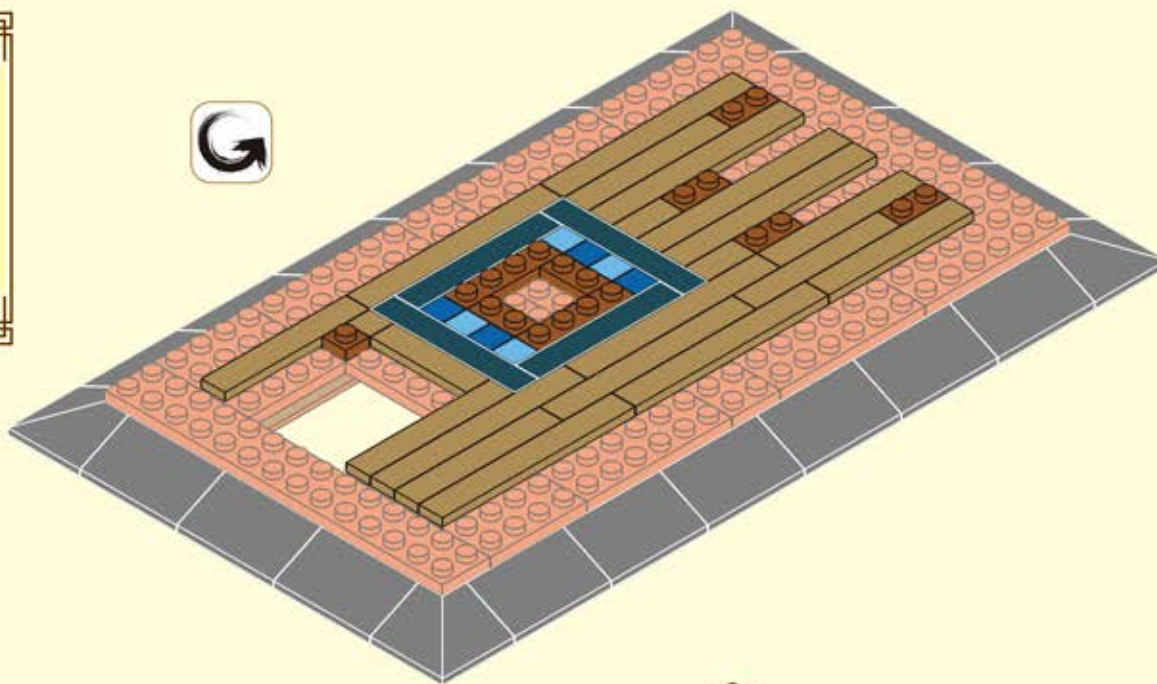

5-19

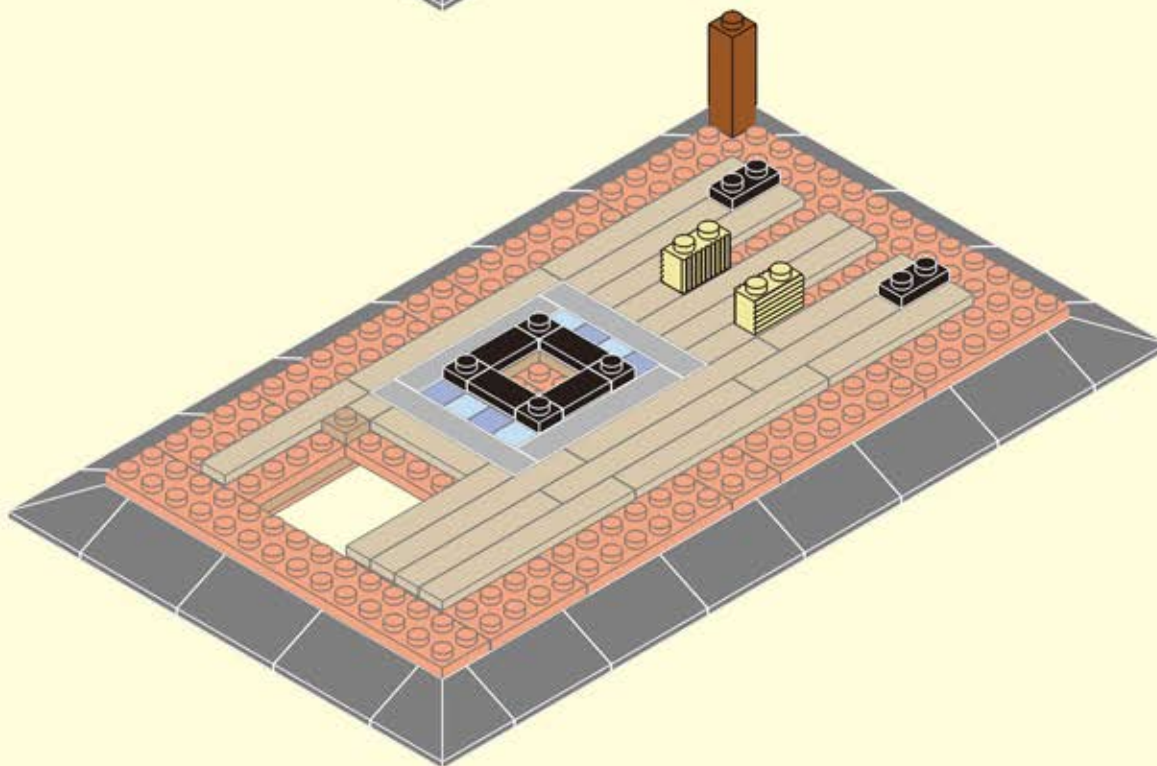

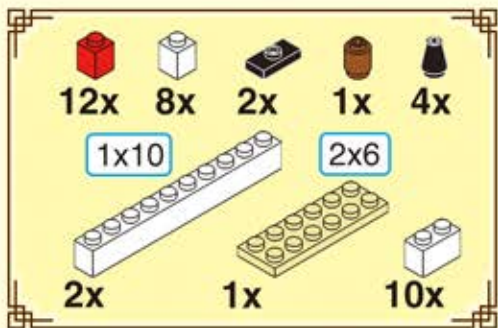

5-20

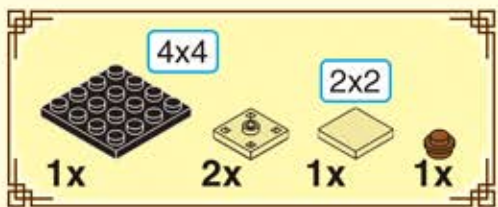
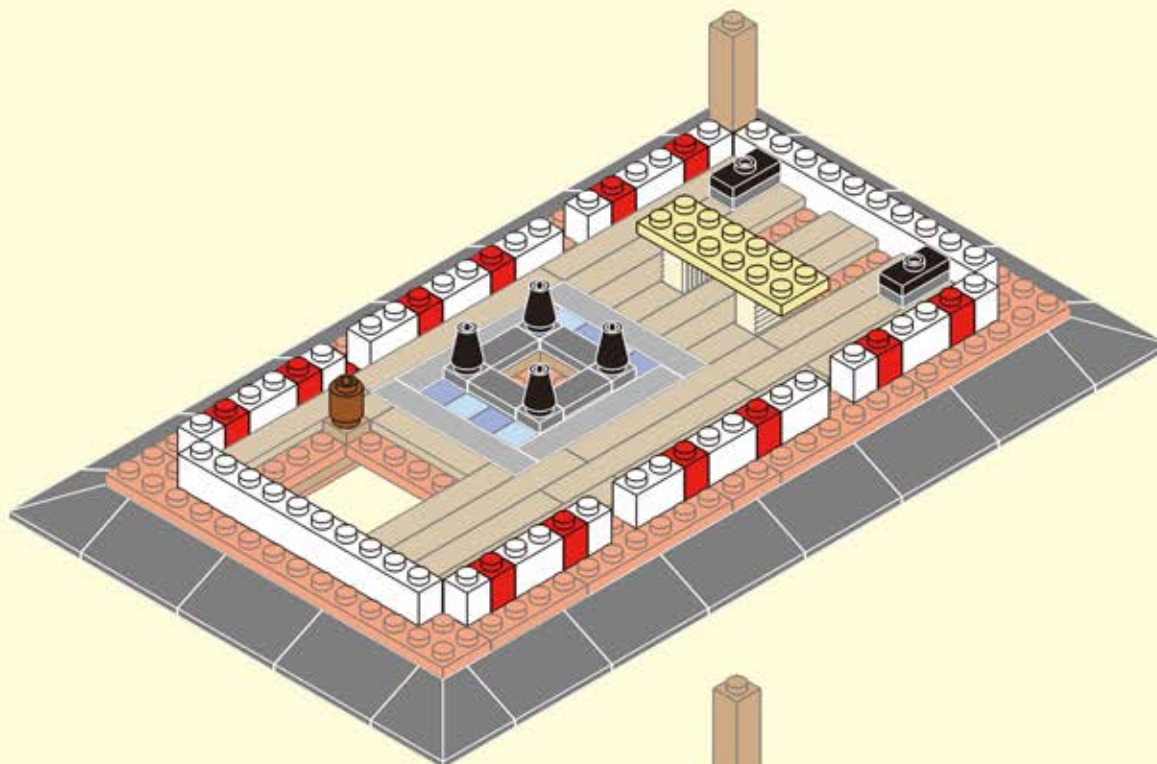

5-21

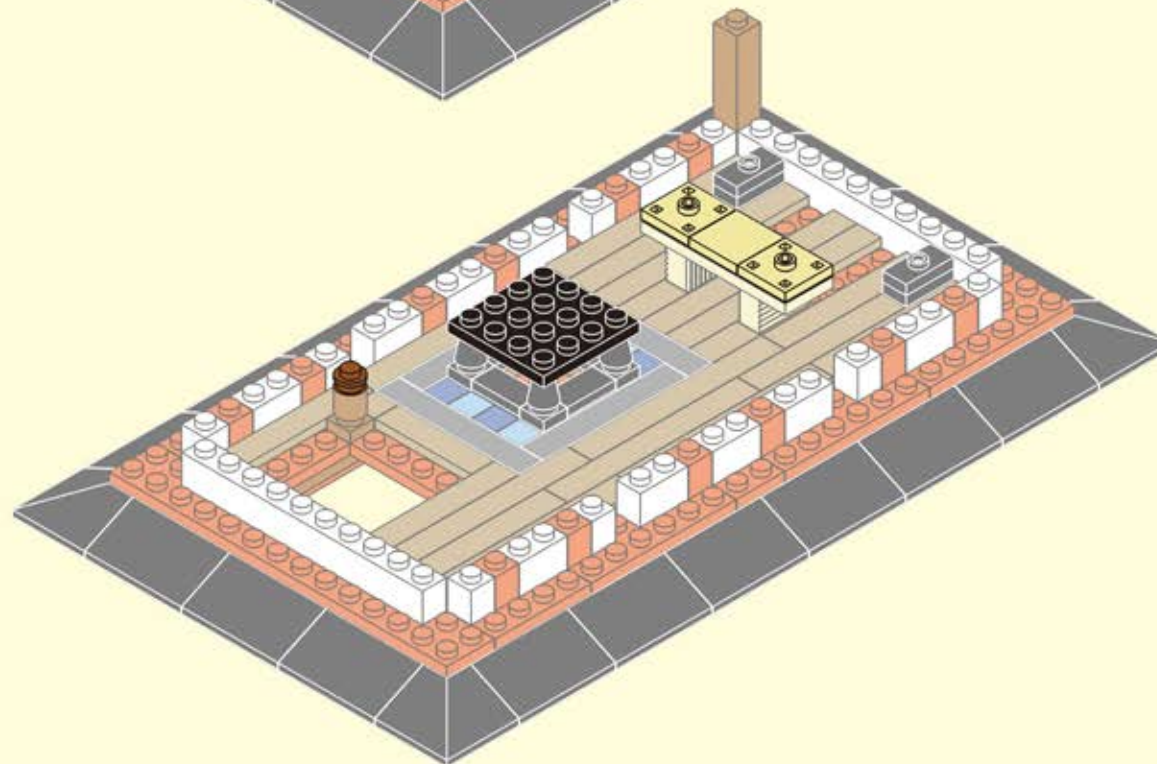



5-22

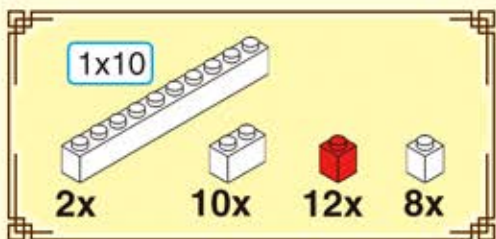

5-23

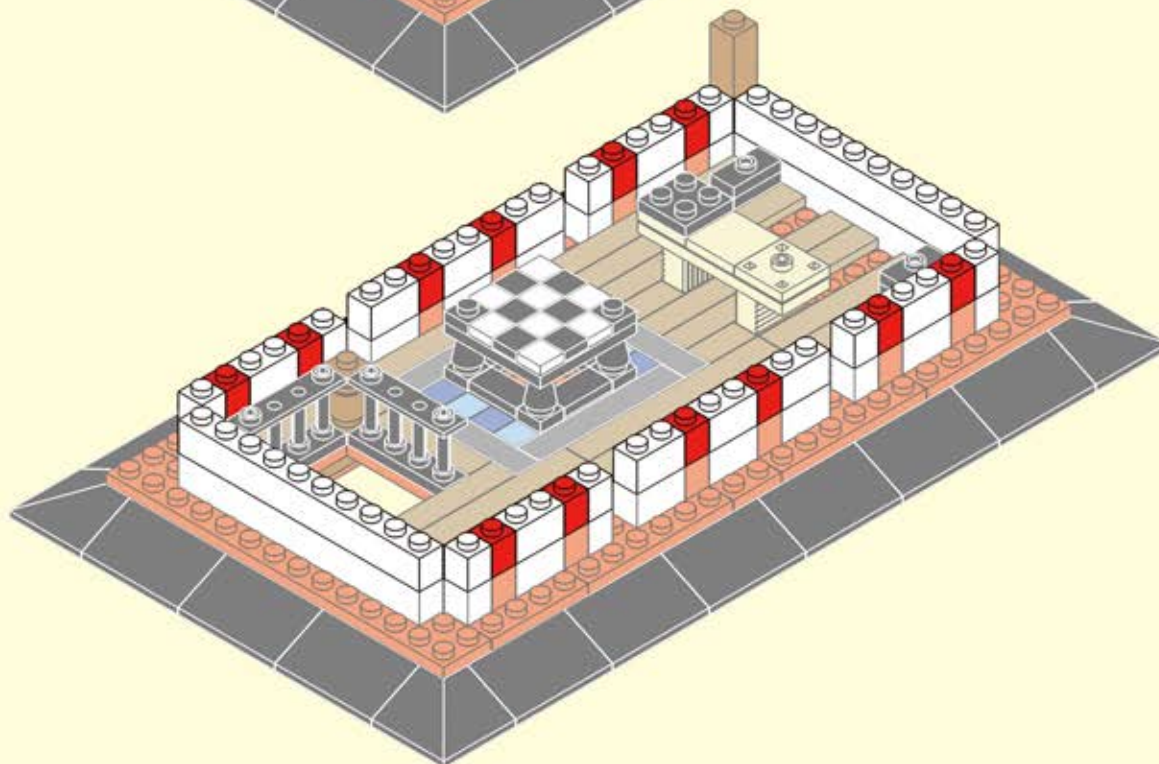



5-24

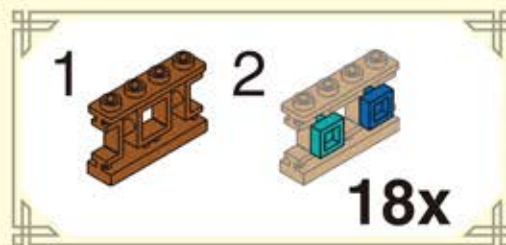

5-25



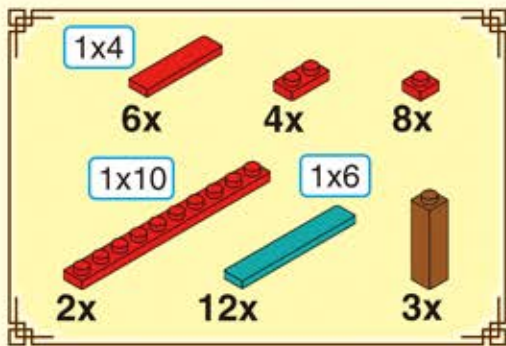

5-26

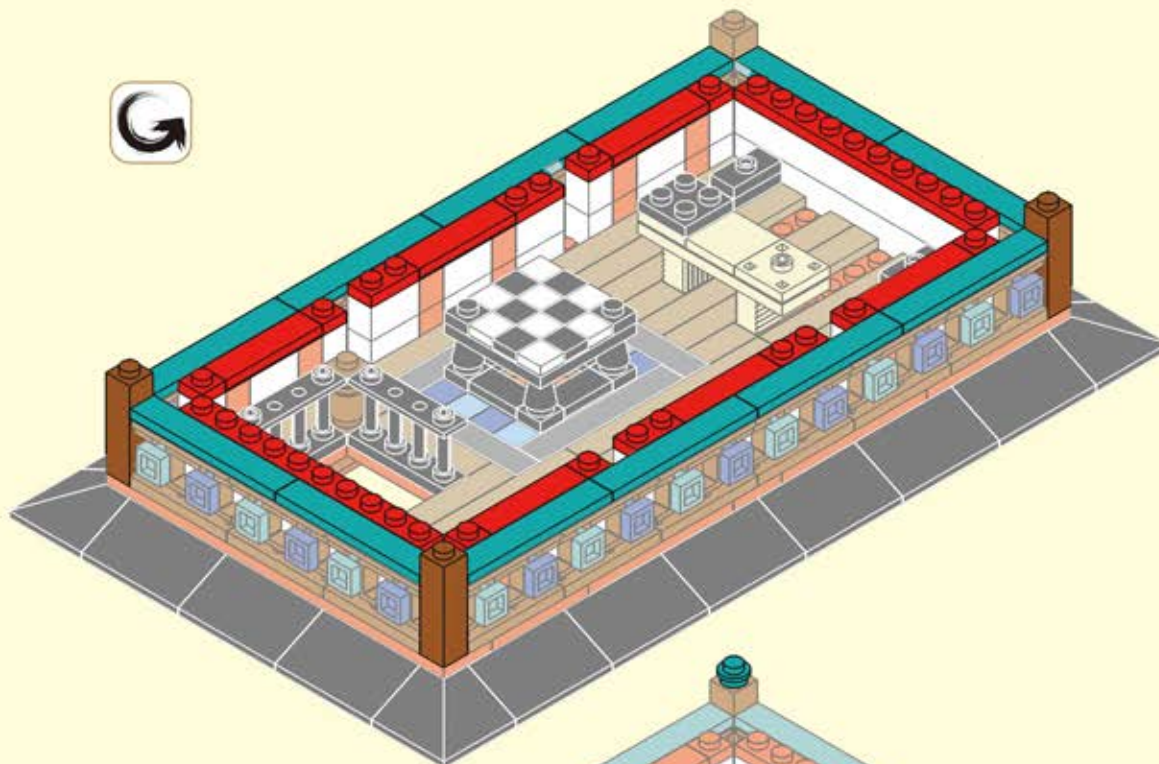

5-27



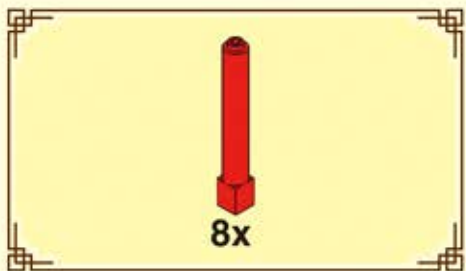

5-28

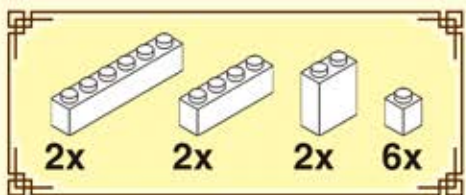
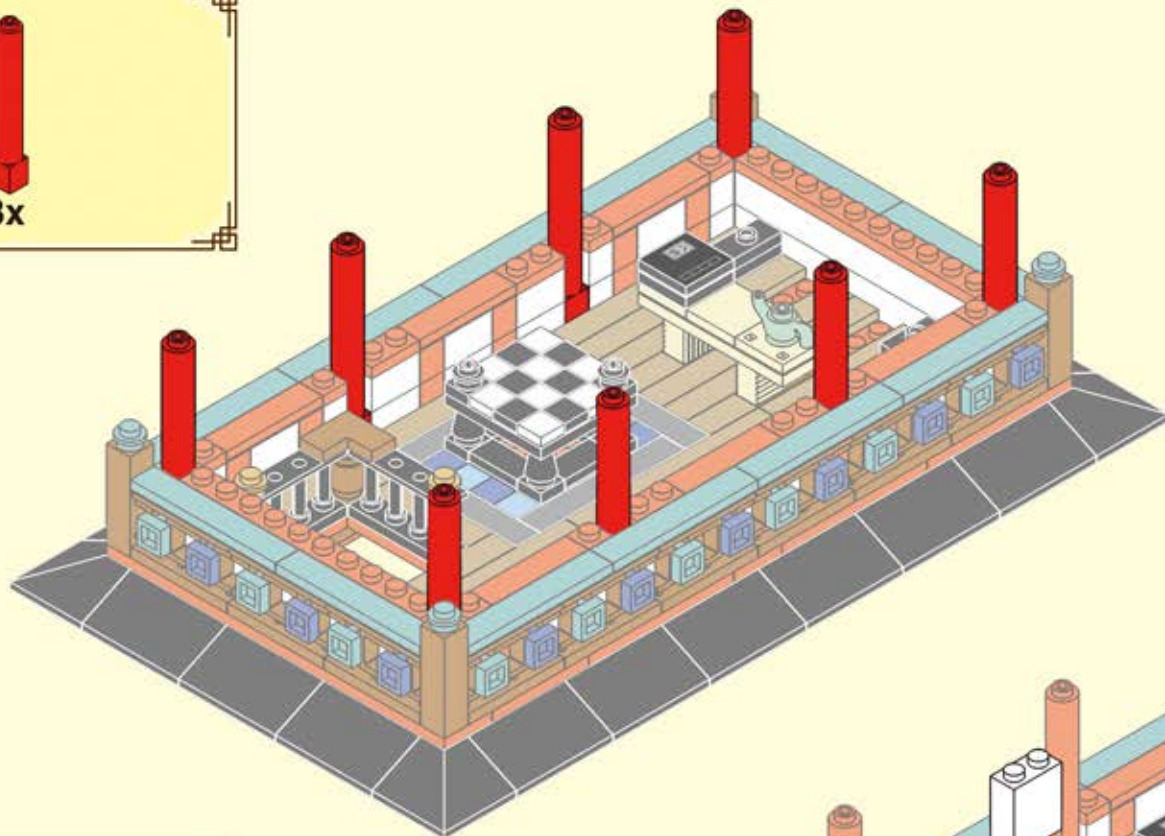

5-29

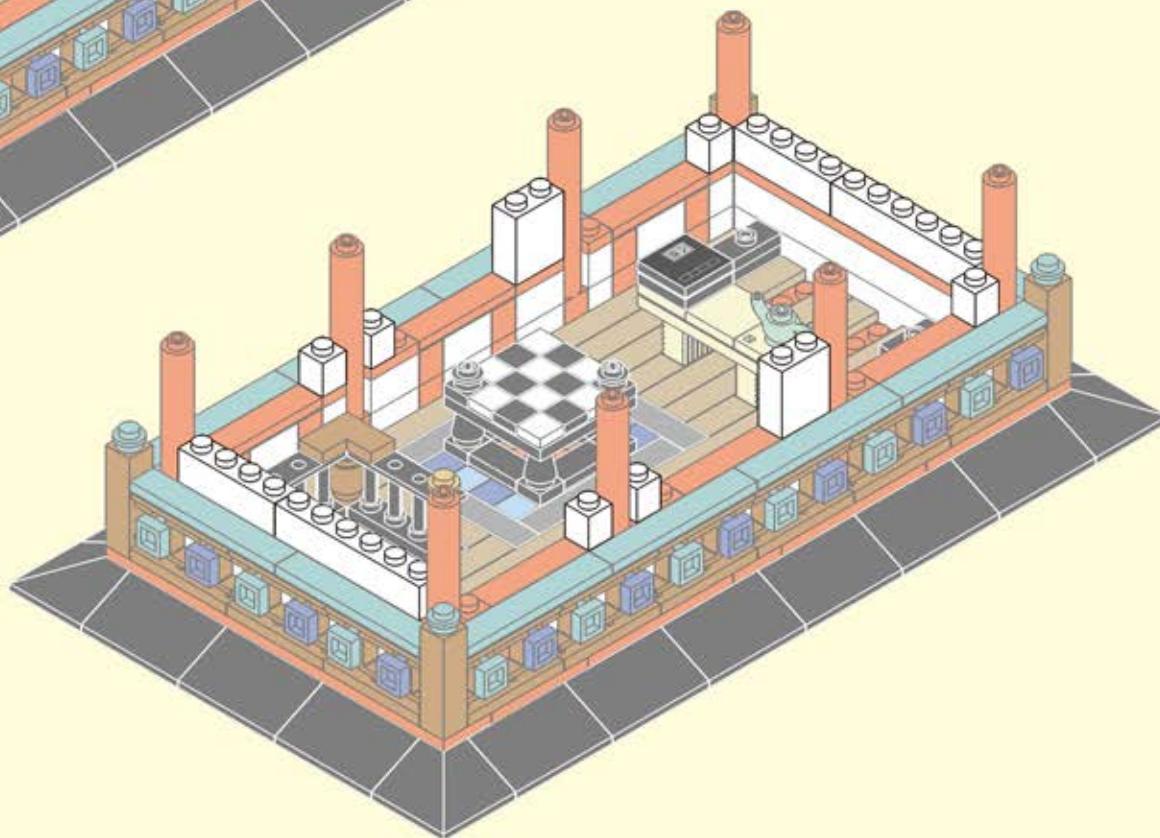

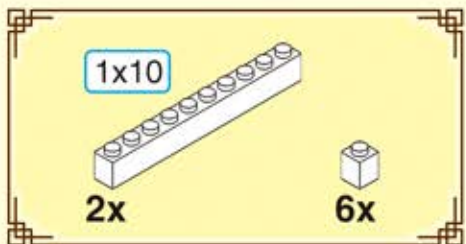

5-30

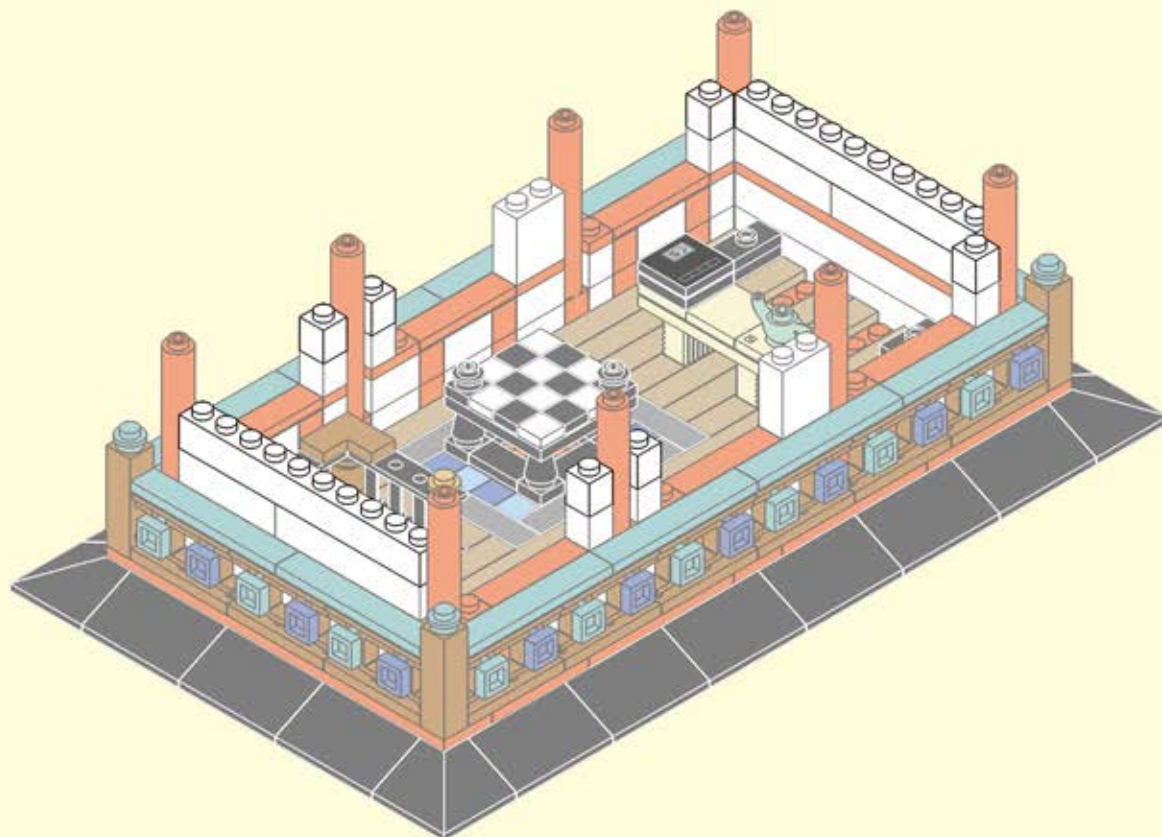

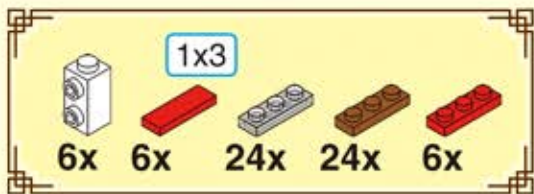

# 5-31

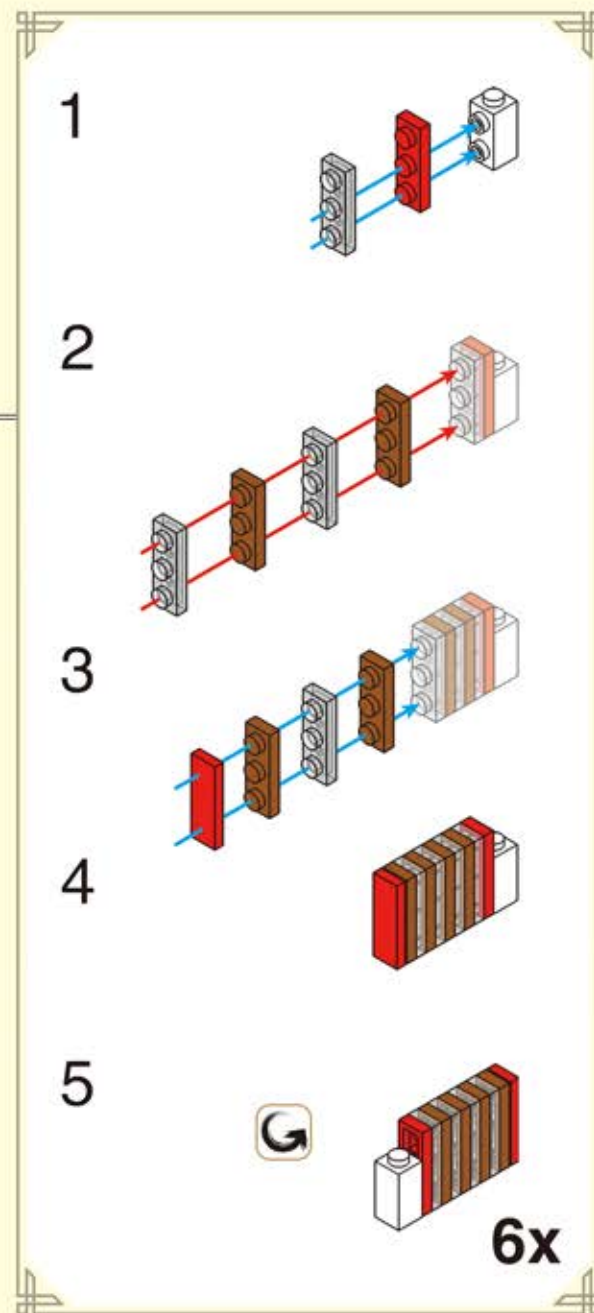
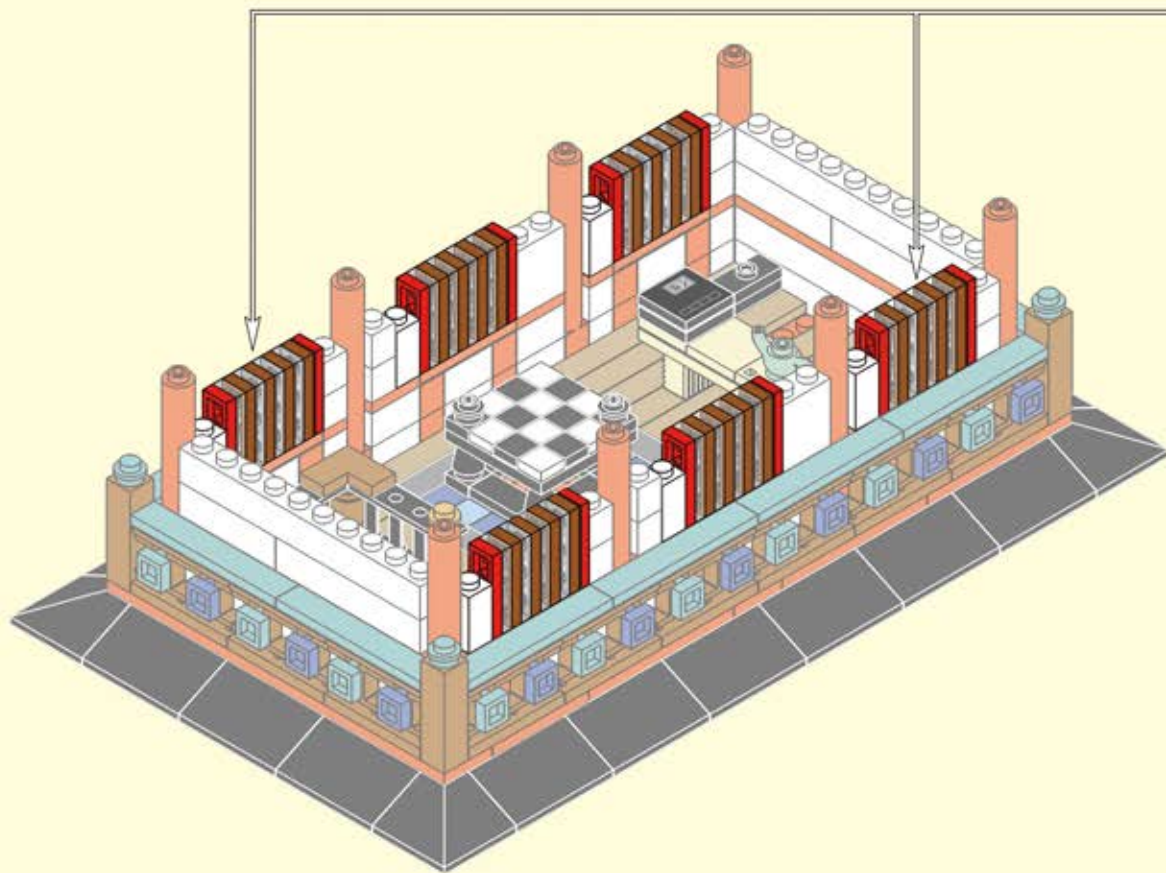

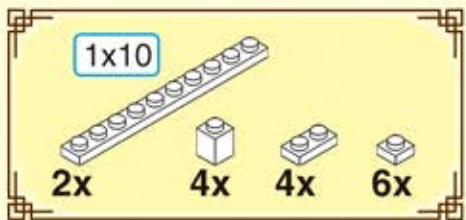

5-32

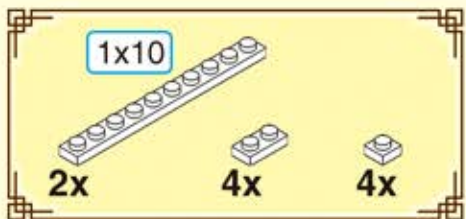
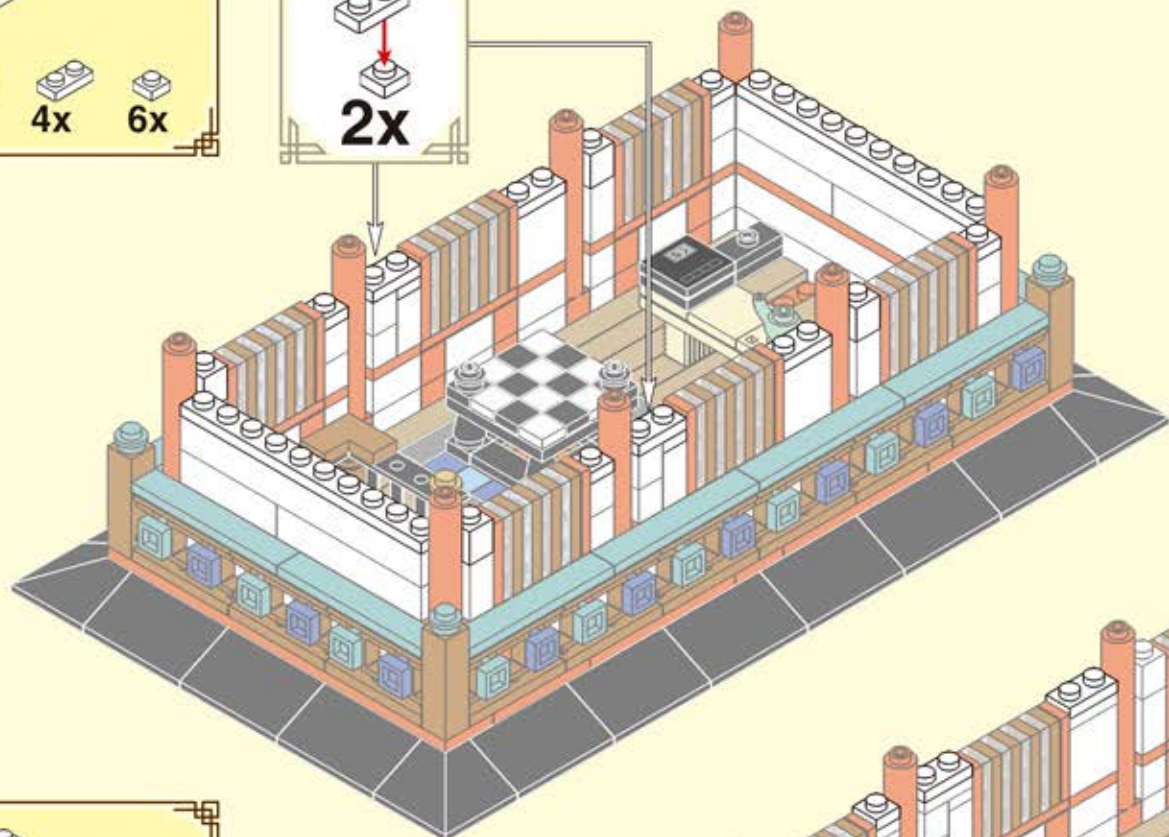

5-33

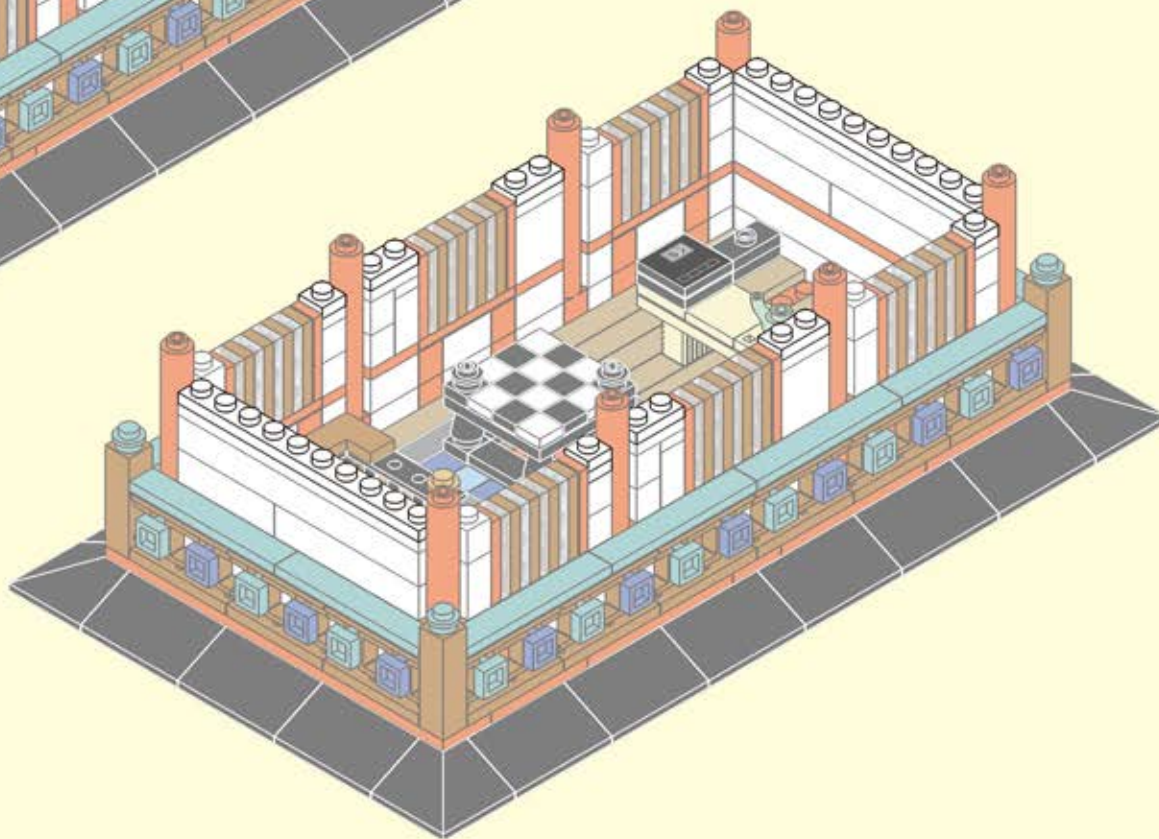

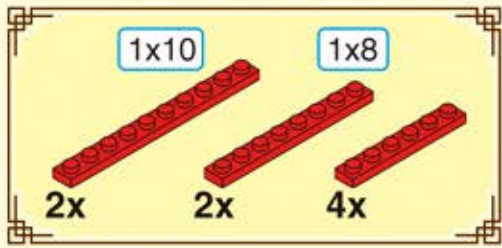

5-34

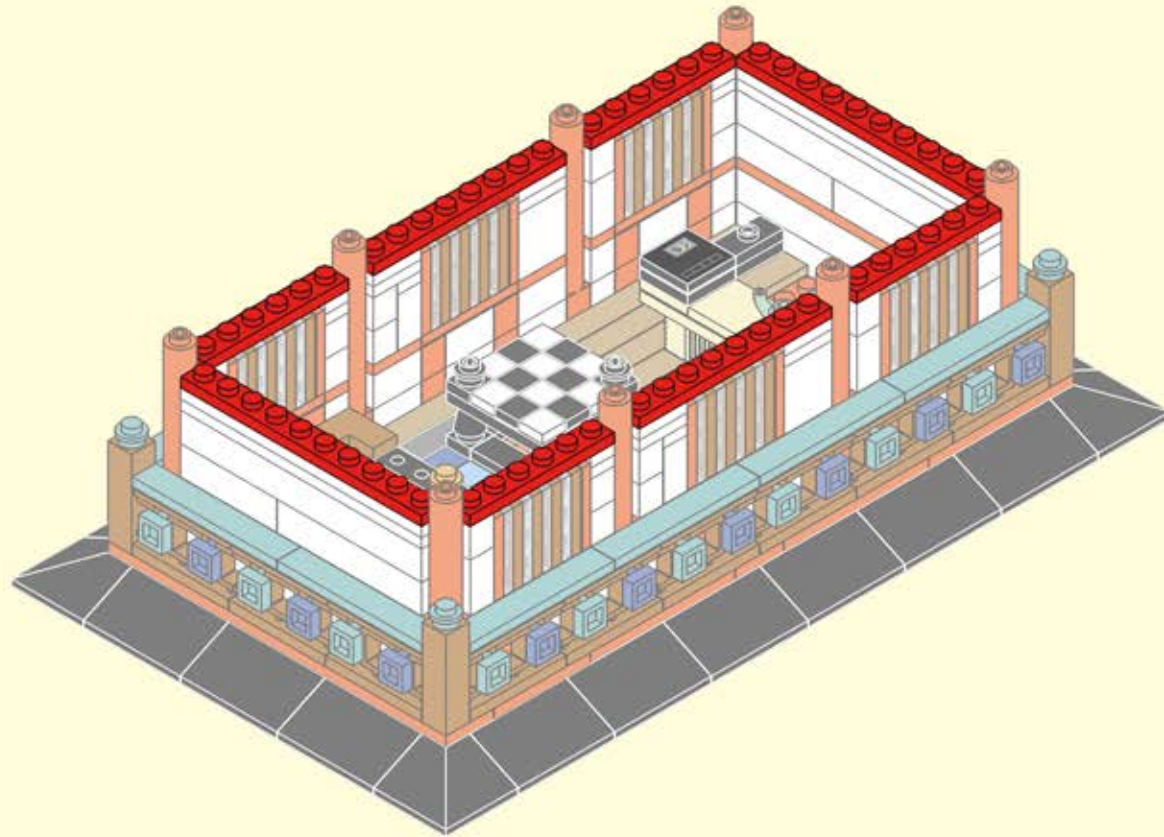

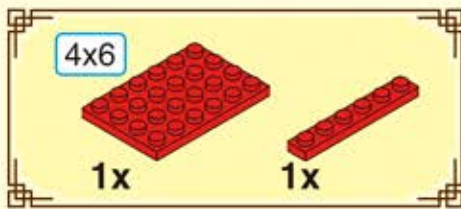

5-35

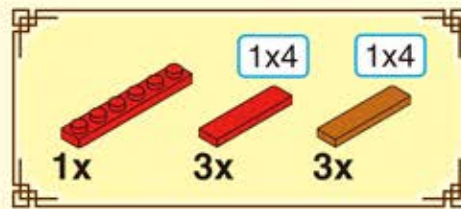
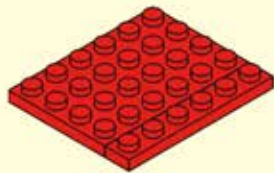

5-36

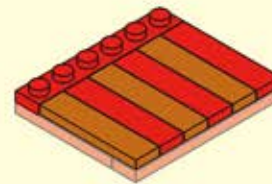

5-37

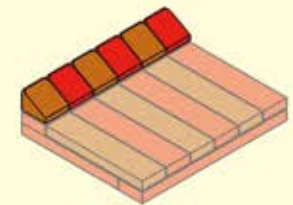

5-38

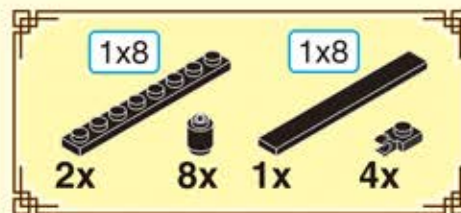
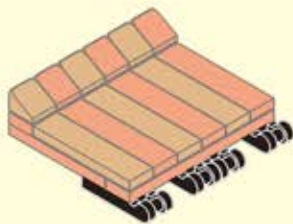

5-39

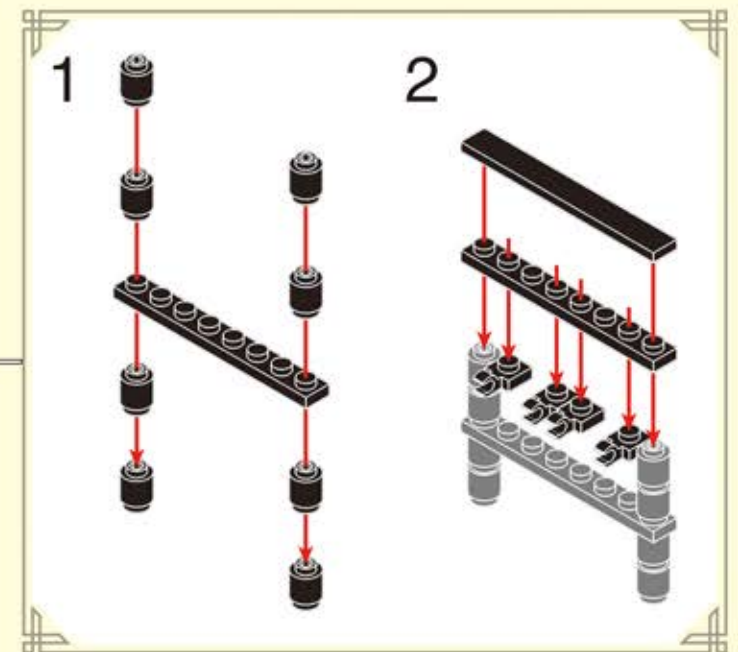
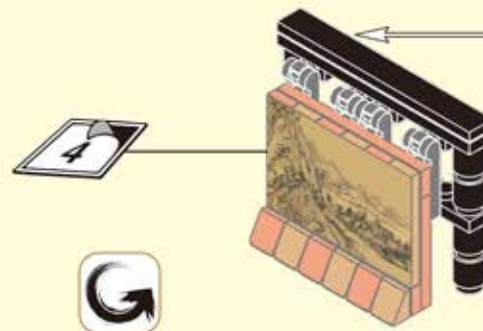

5-40

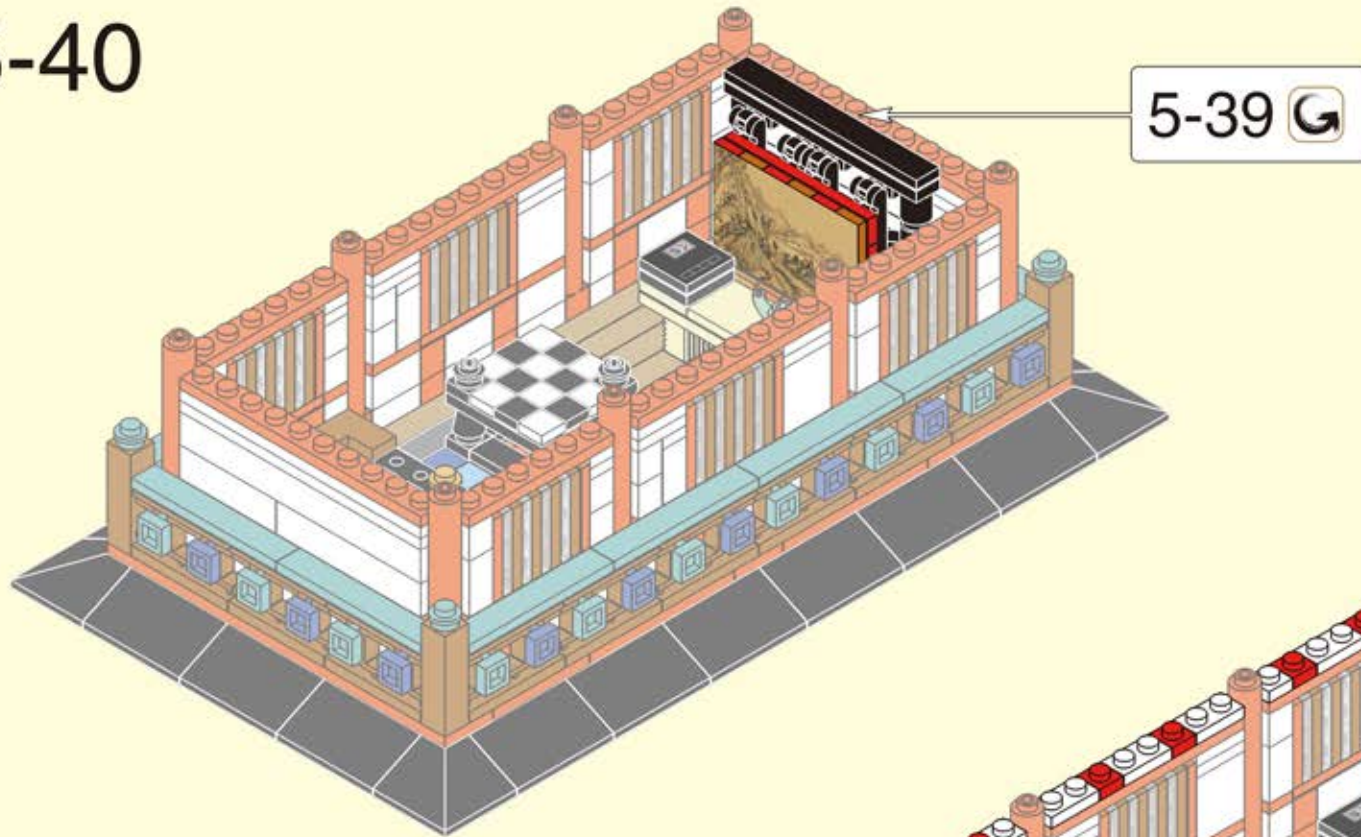

5-39 

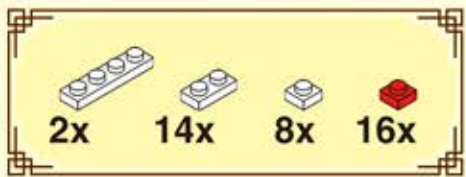

5-41

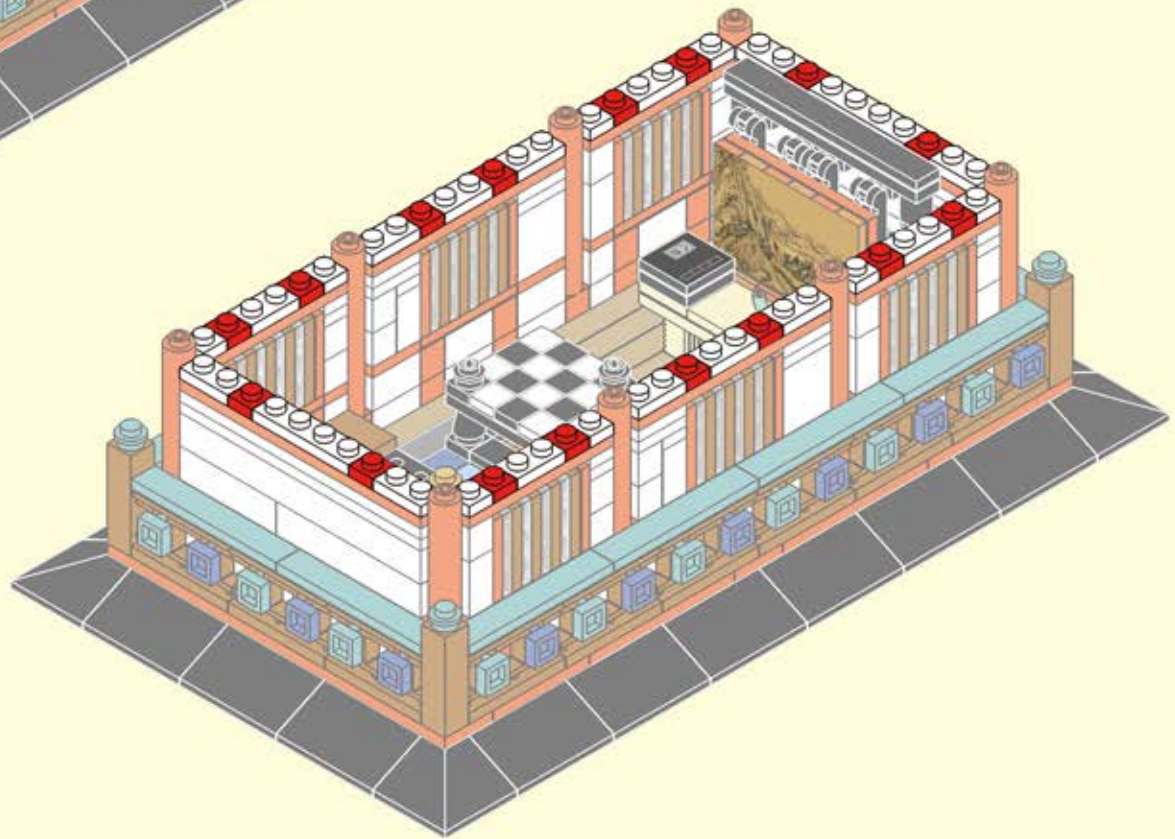

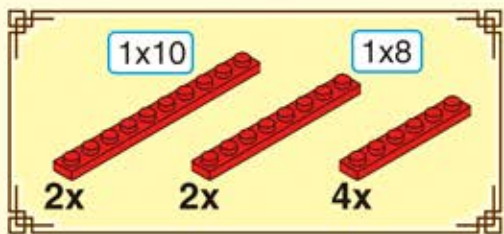

5-42

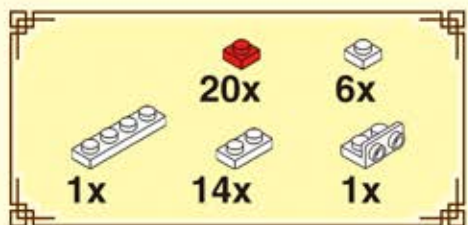

5-43

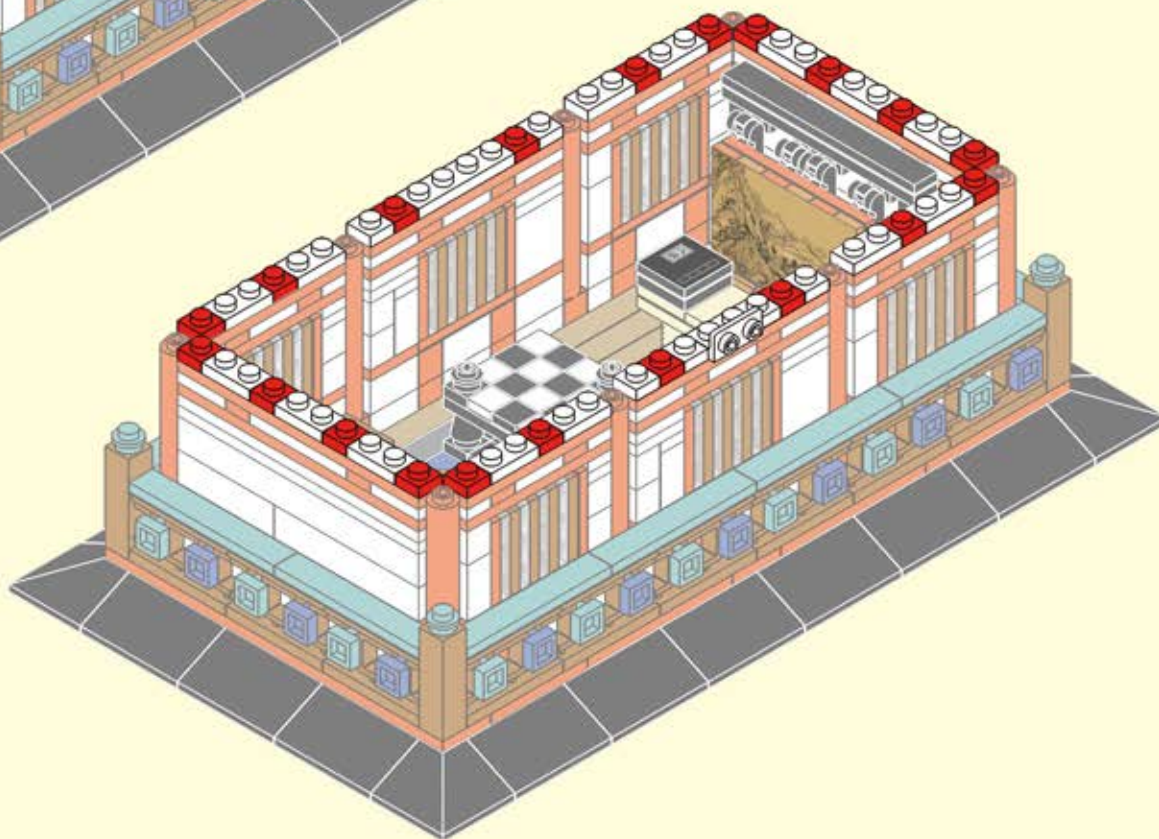



5-44

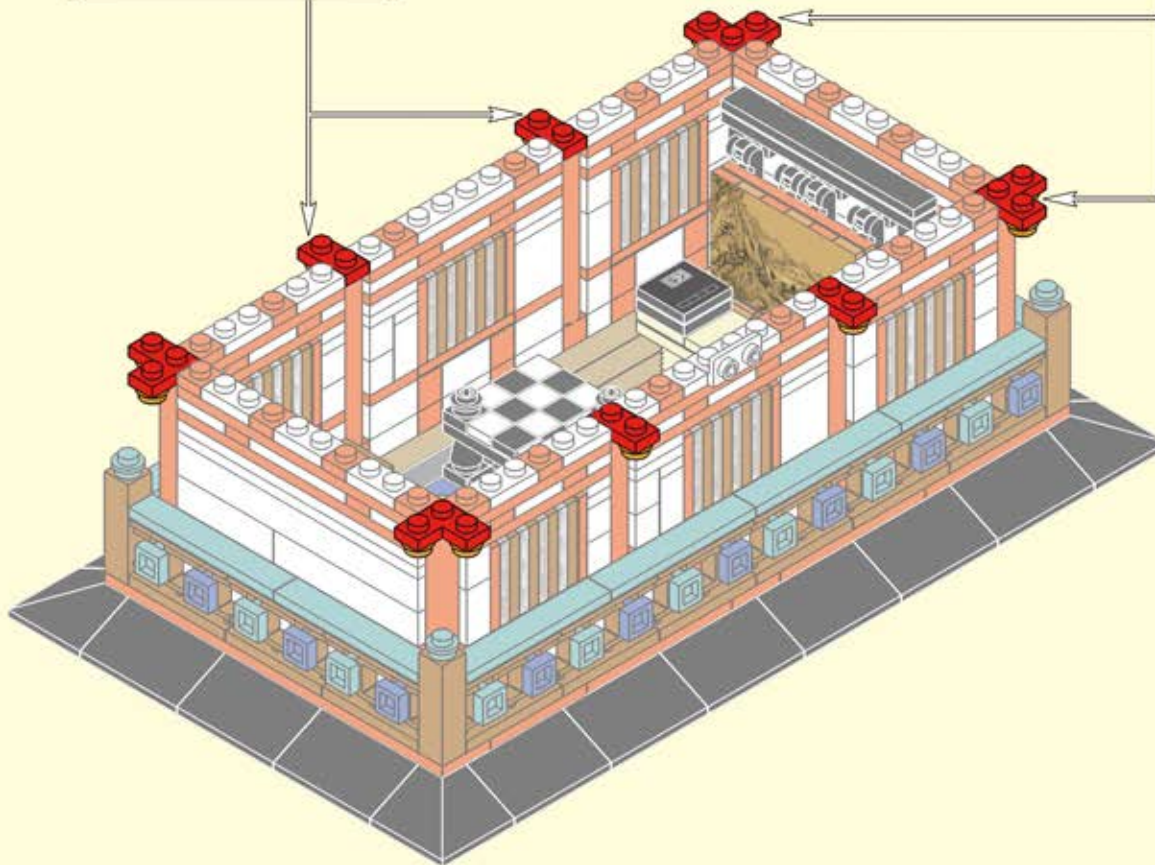
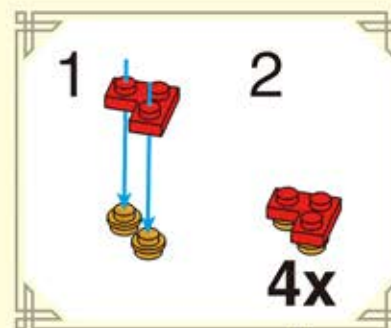
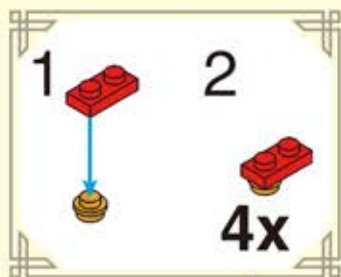

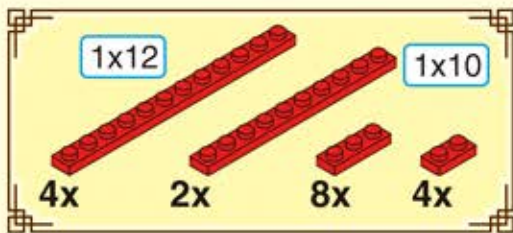

5-45

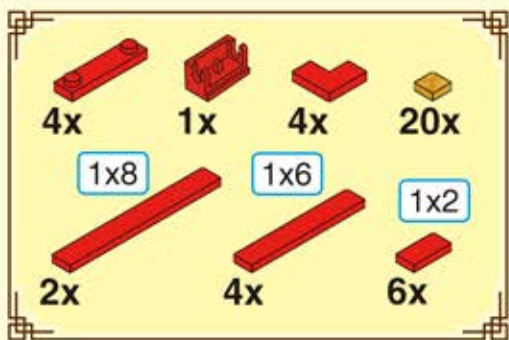
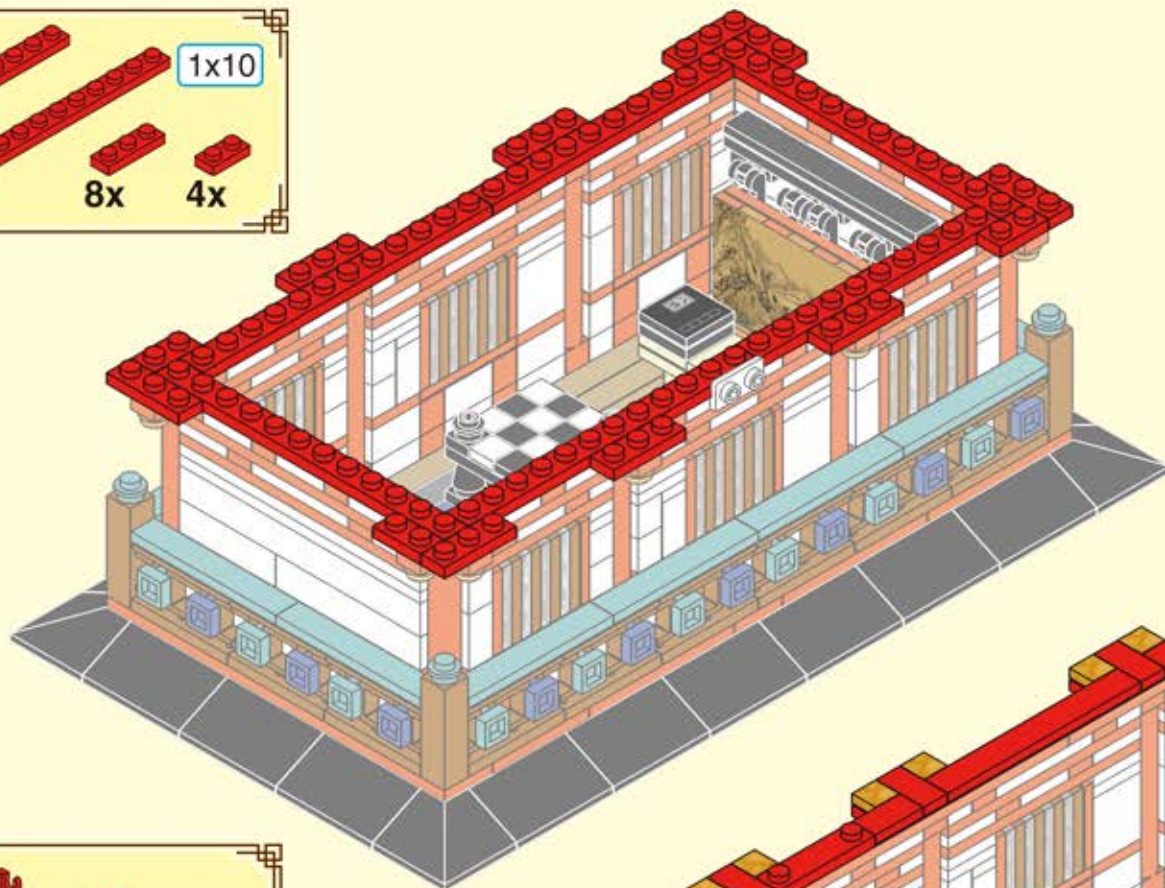

5-46

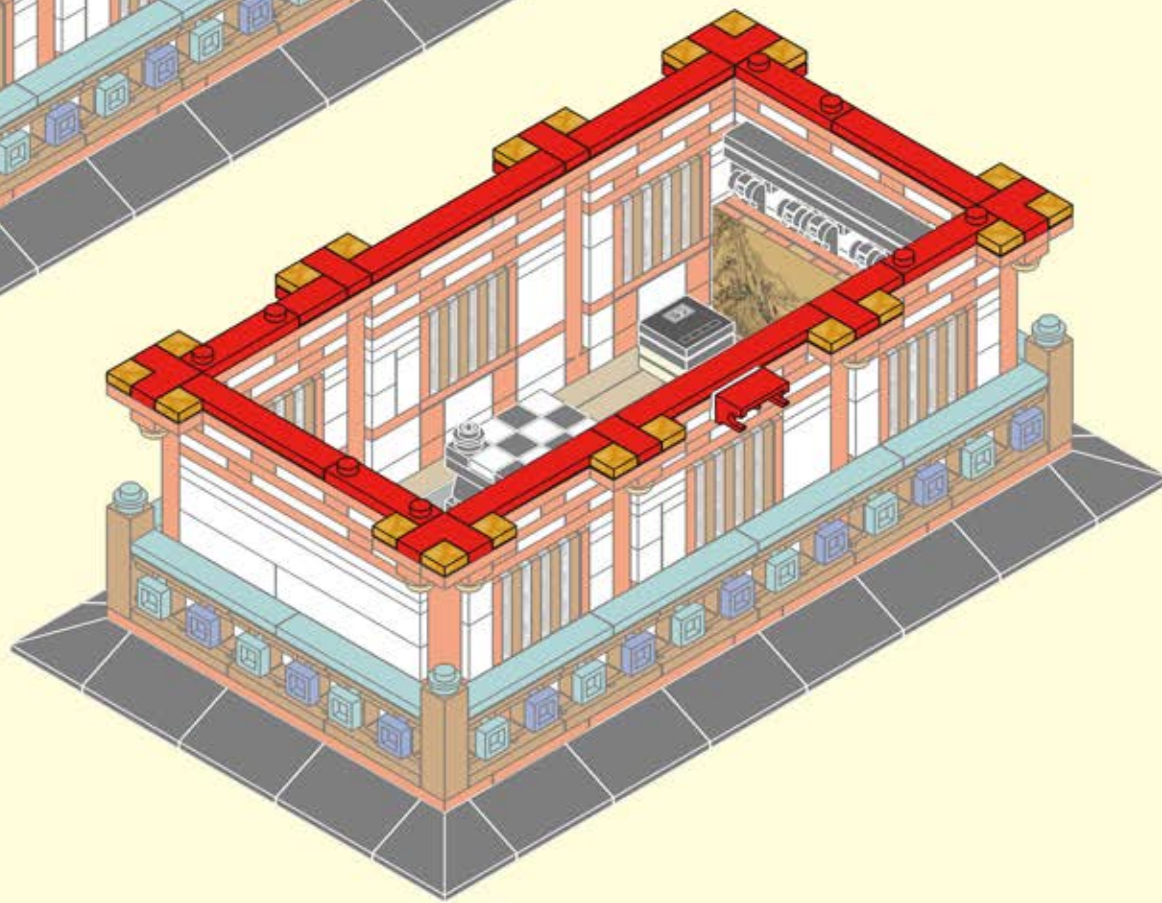

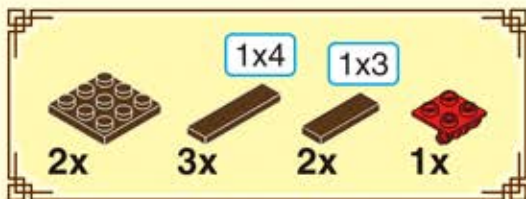

5-47

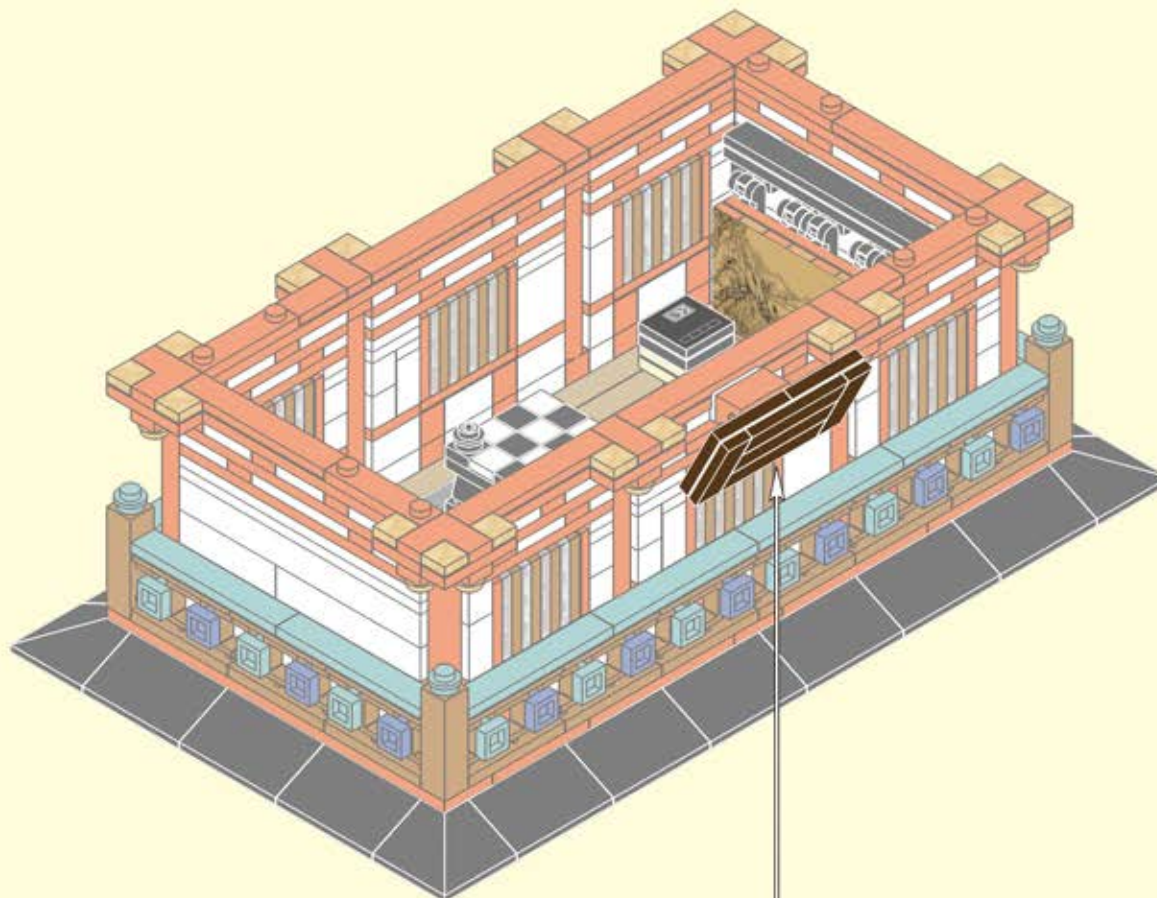



5-48

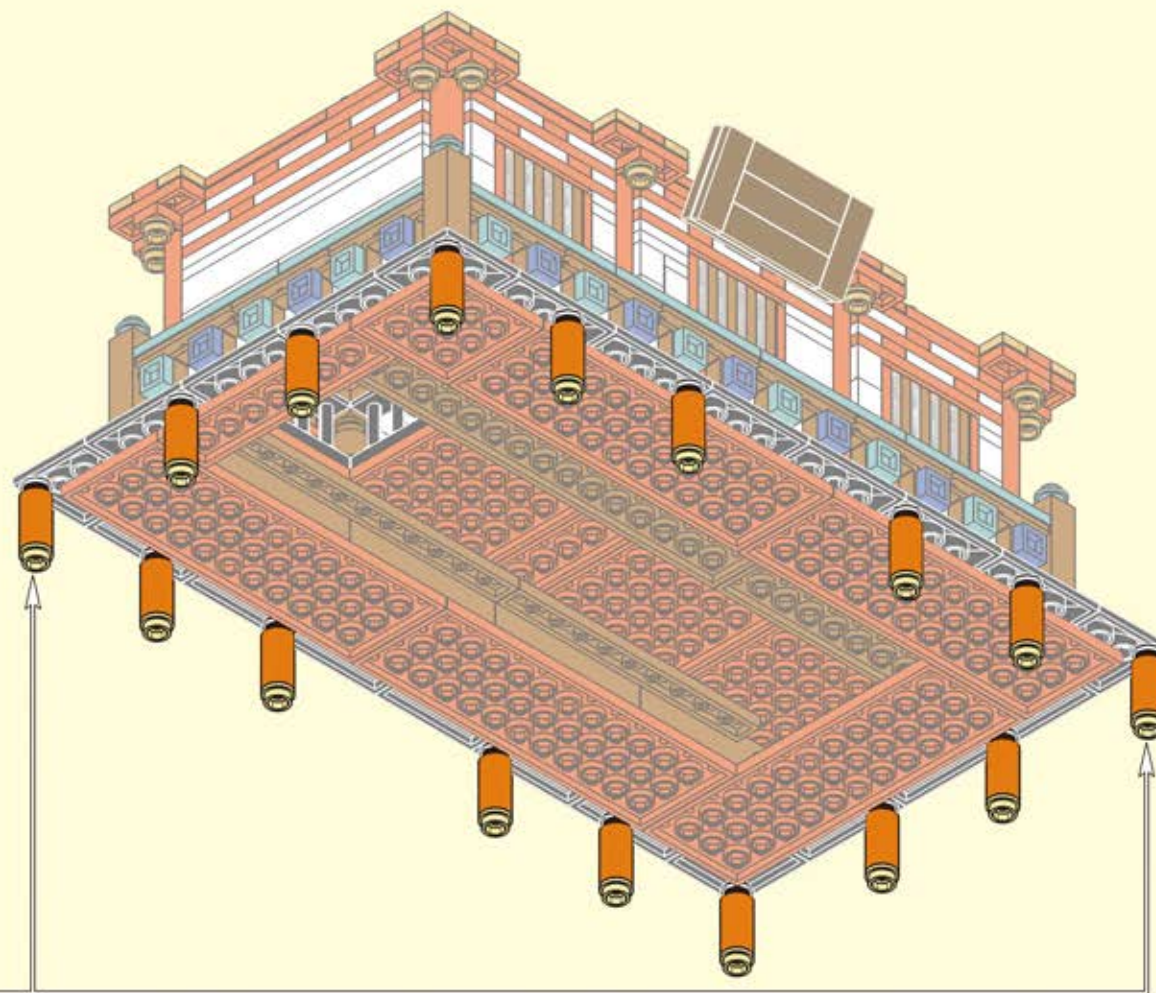
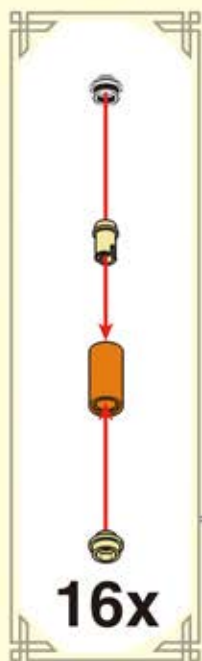

5-49

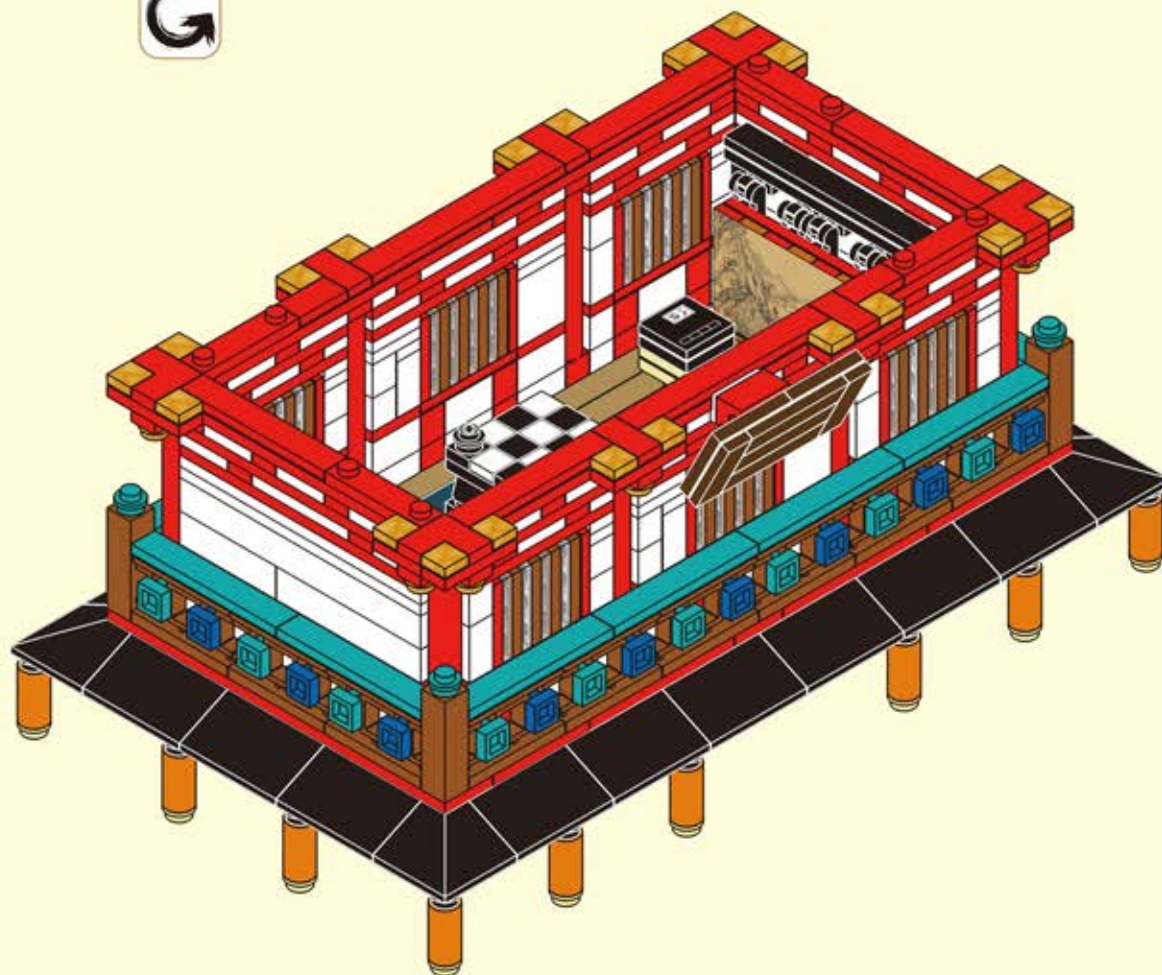

5-50



5-51

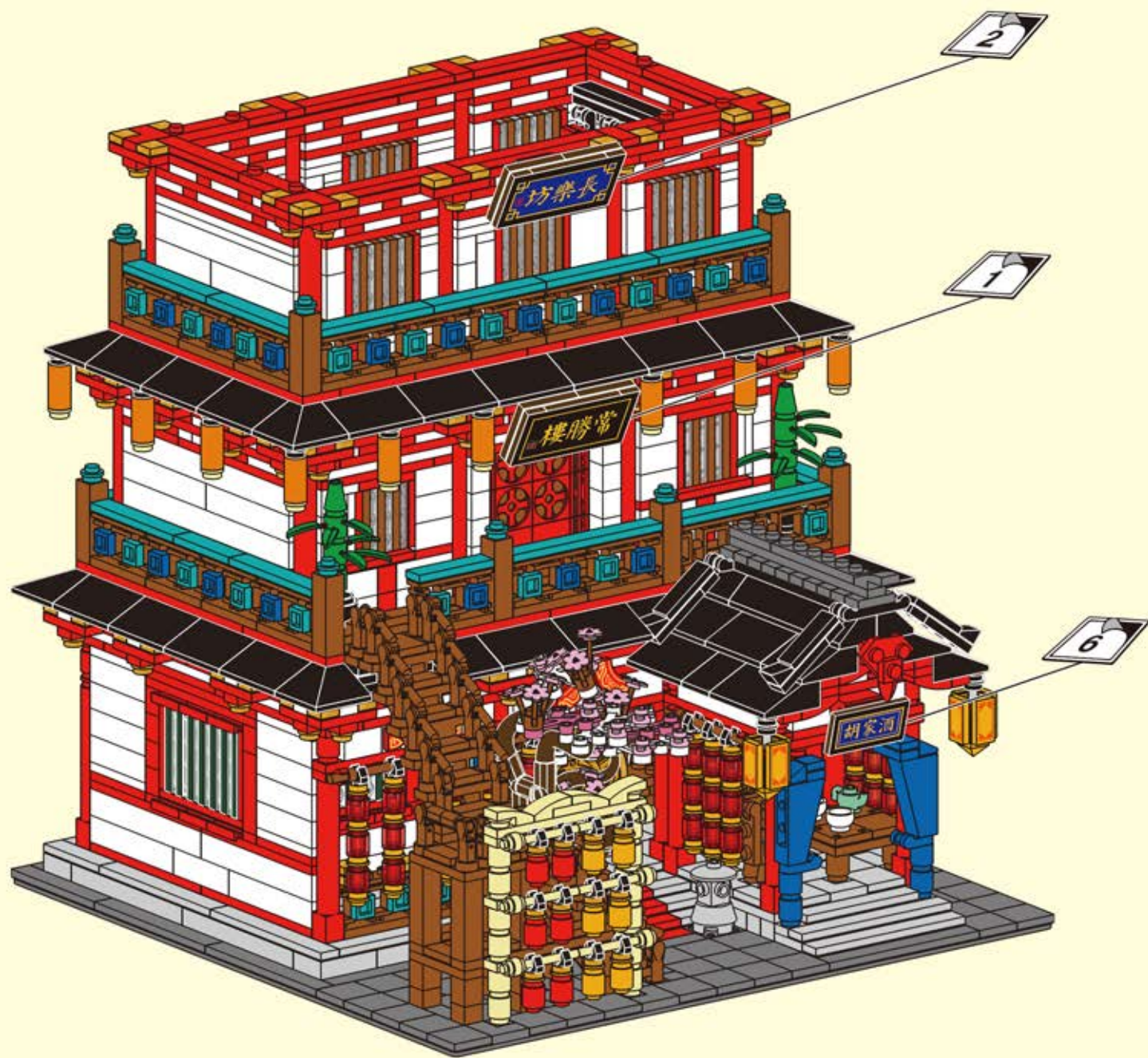







6-3

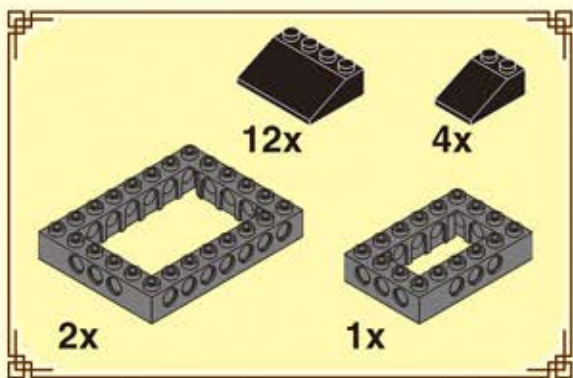
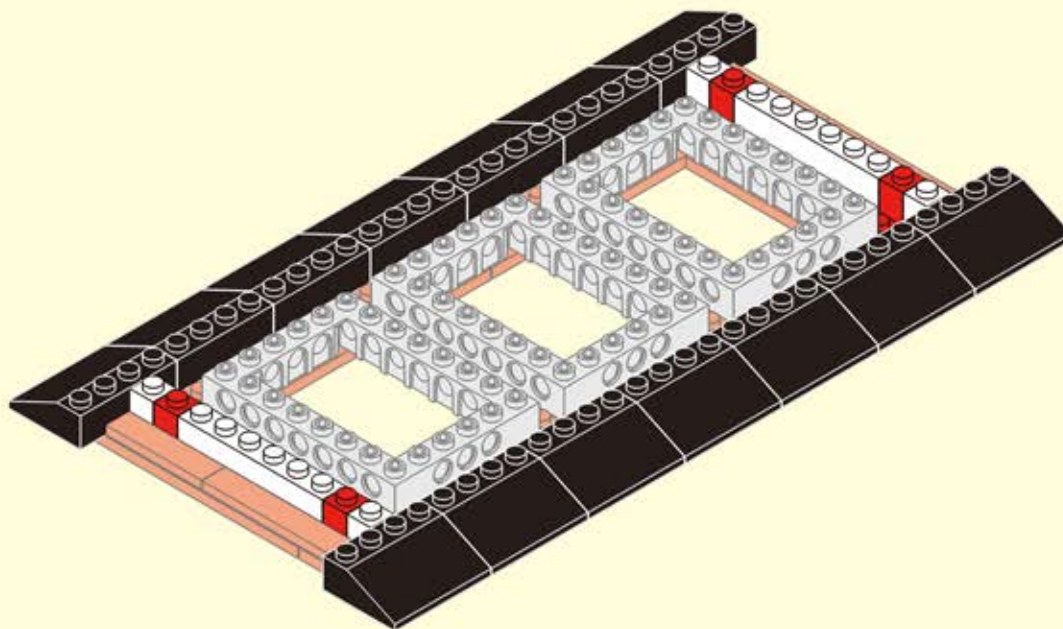

6-4

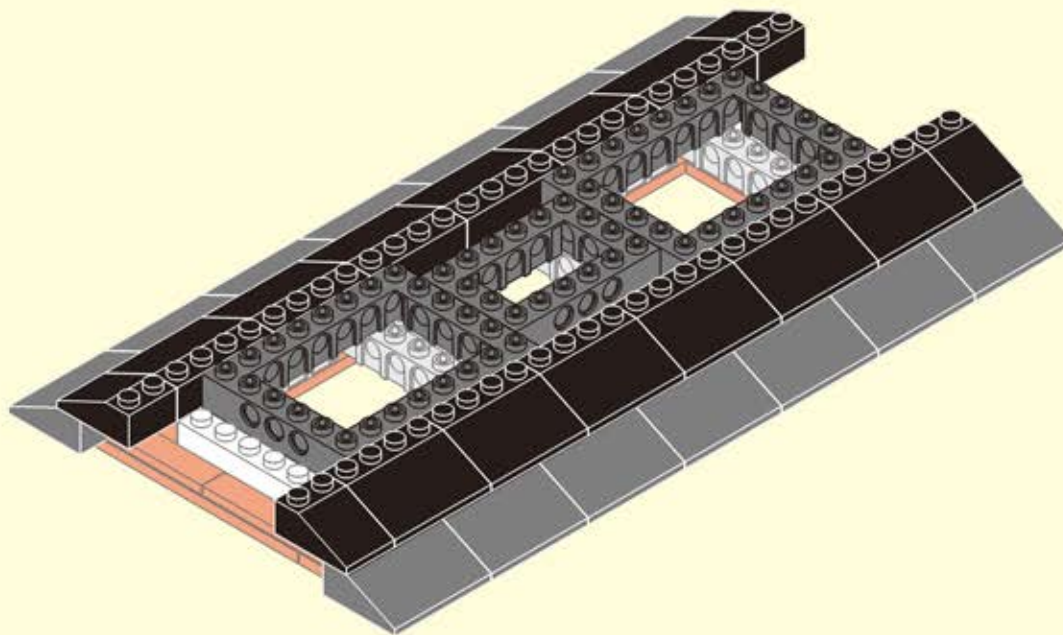

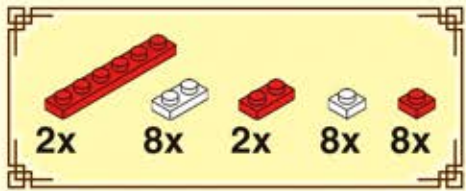

6-5

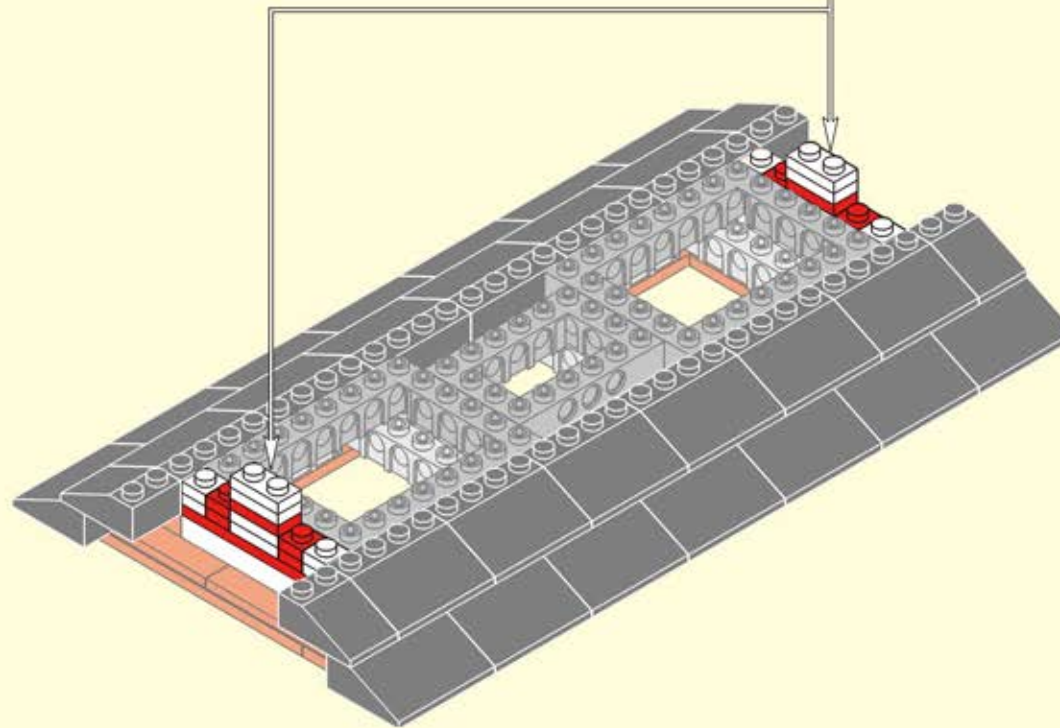
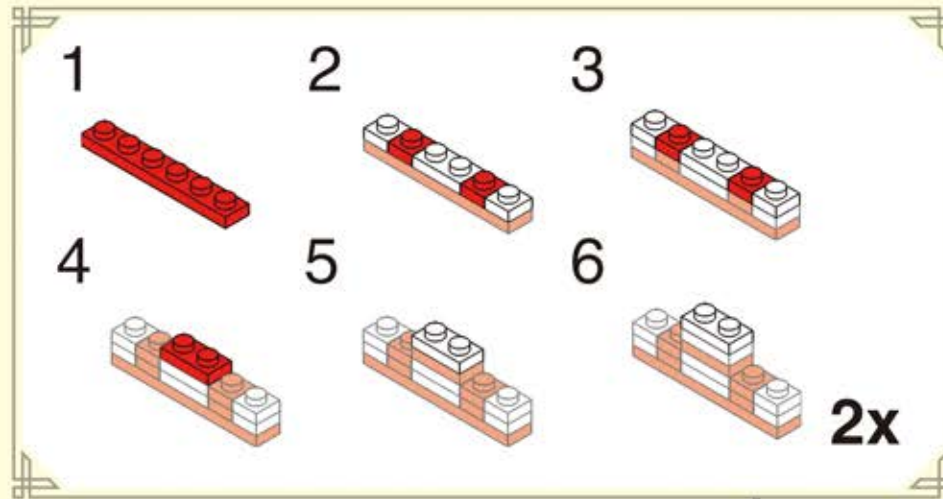

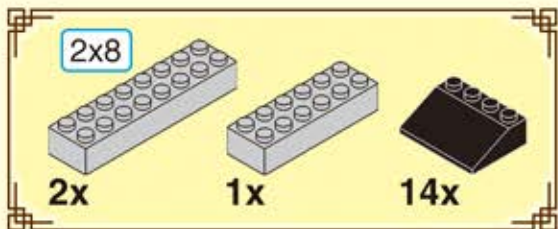

6-6

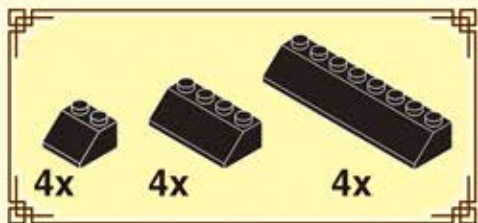
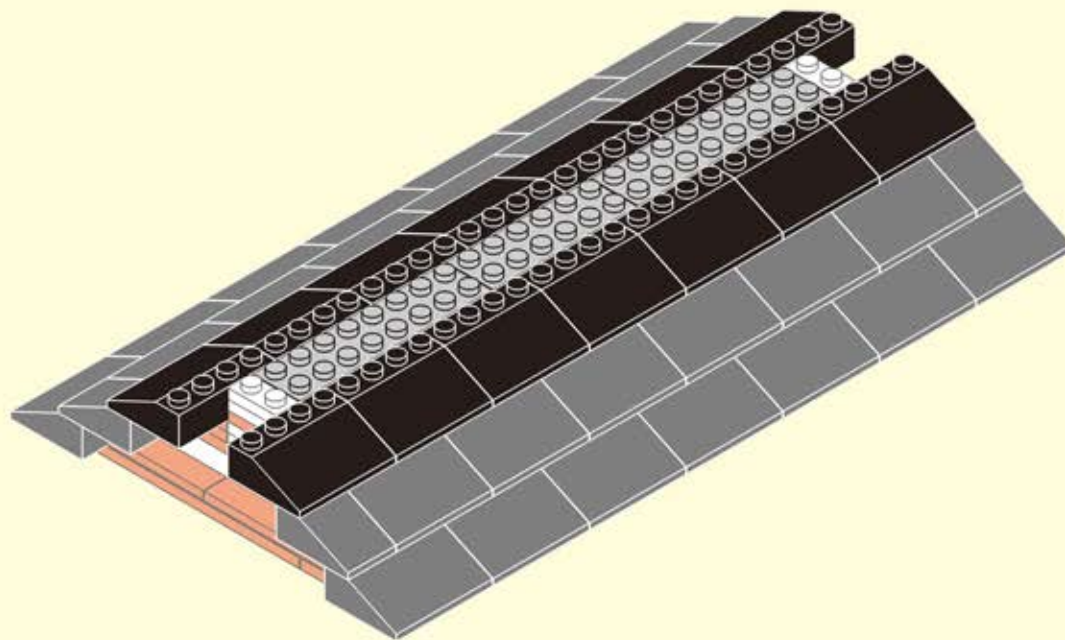

6-7

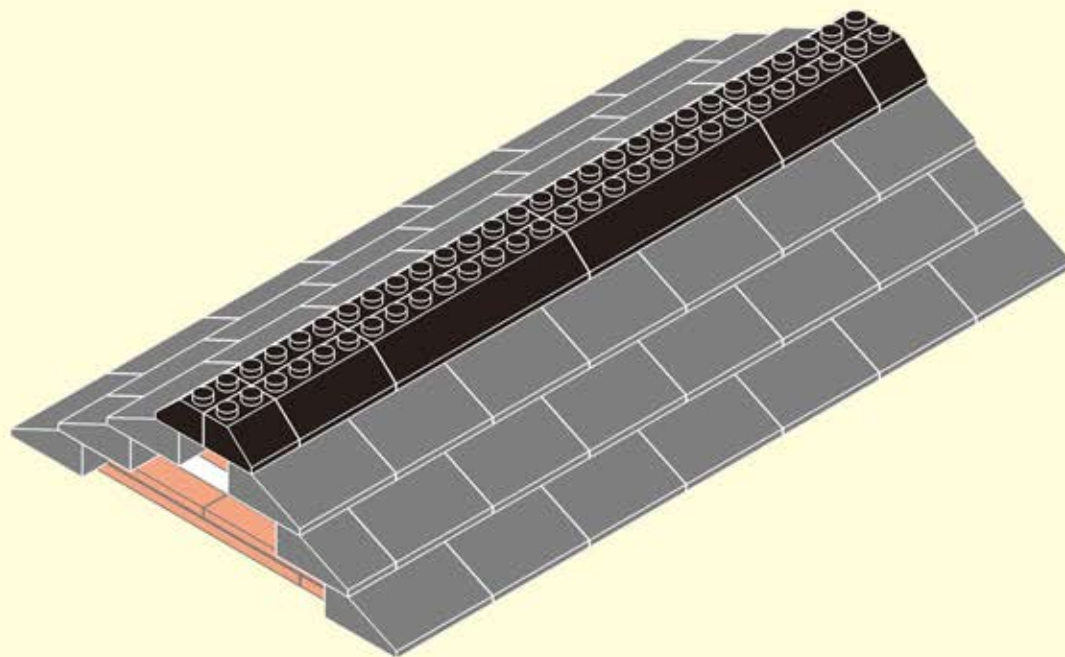



6-8

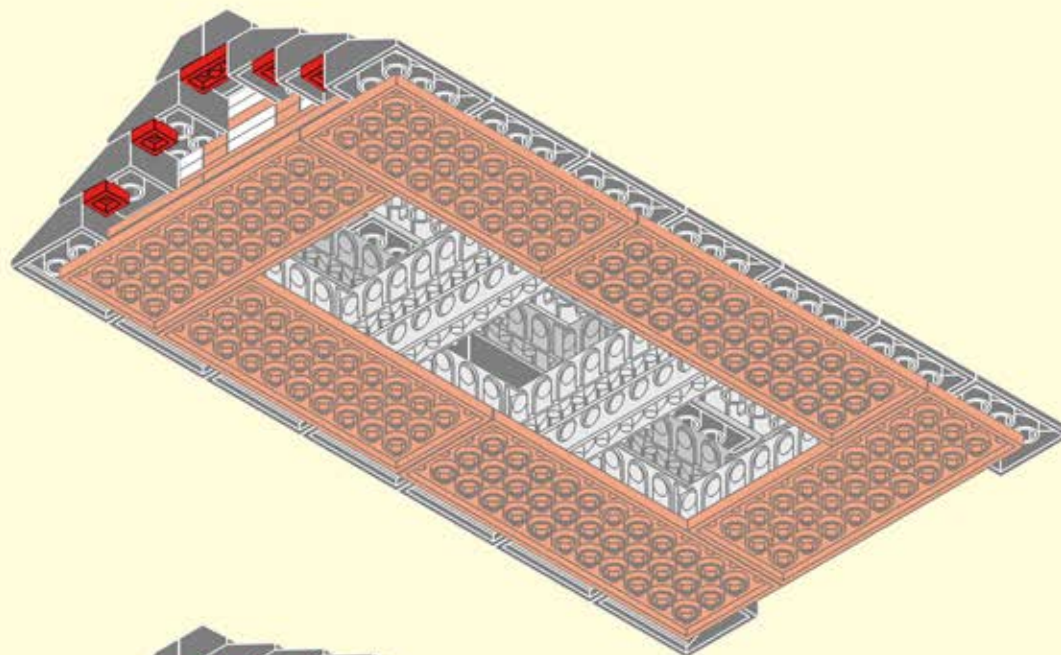

6-9

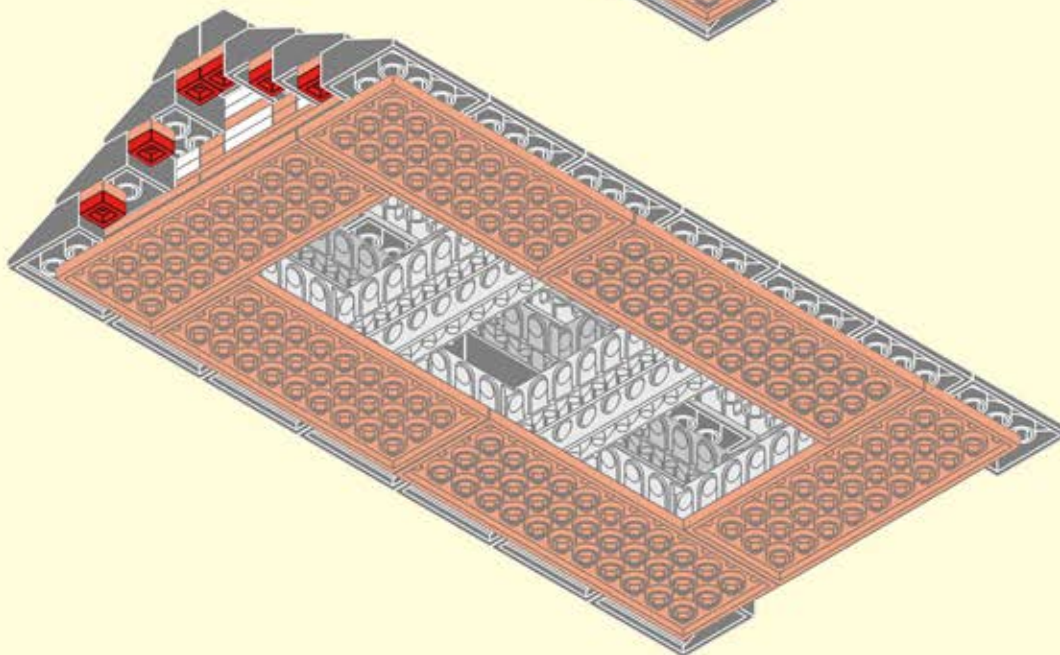



6-10

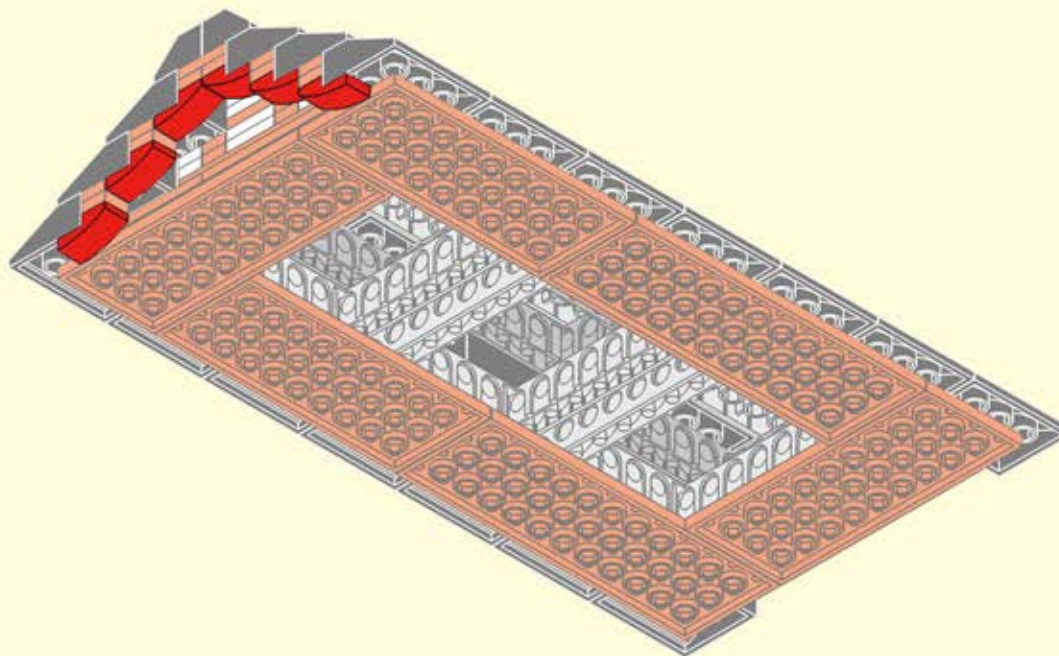

6-11

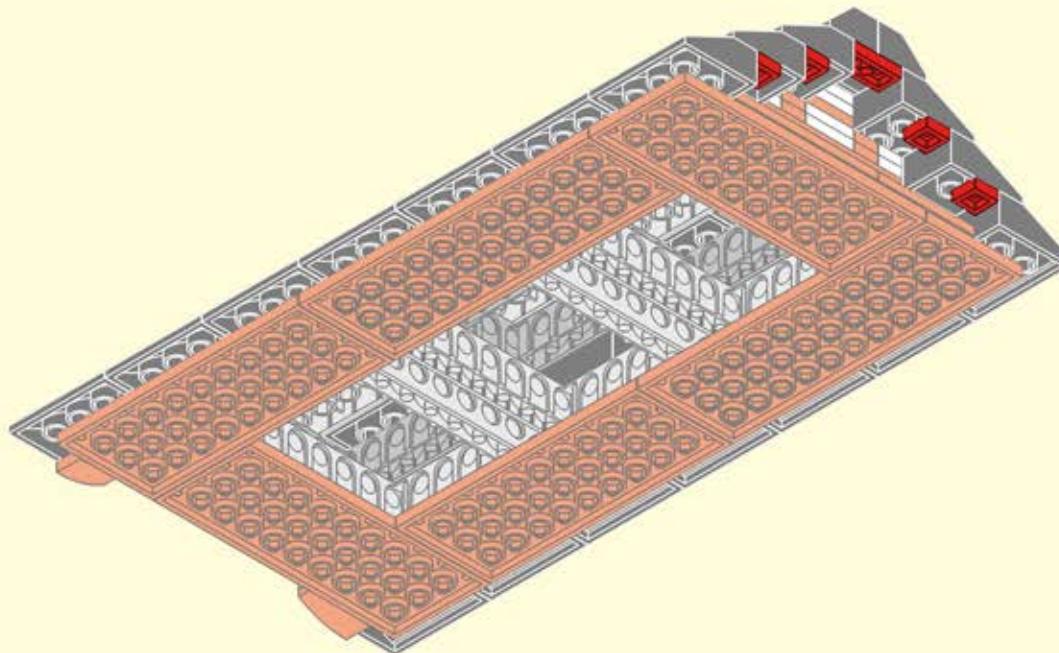



6-12

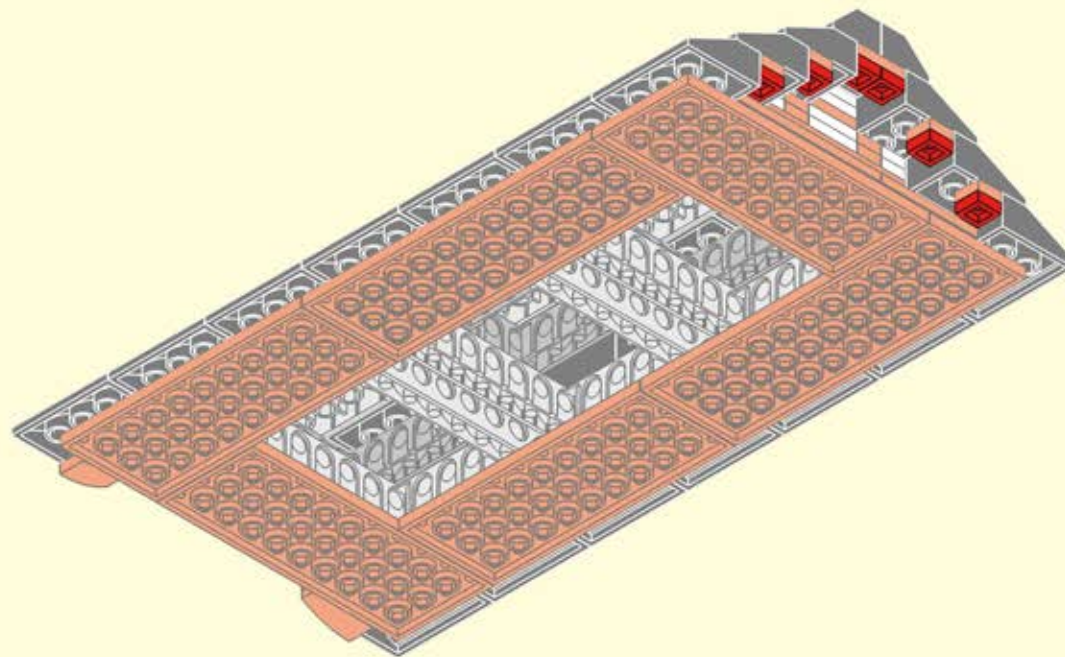

6-13

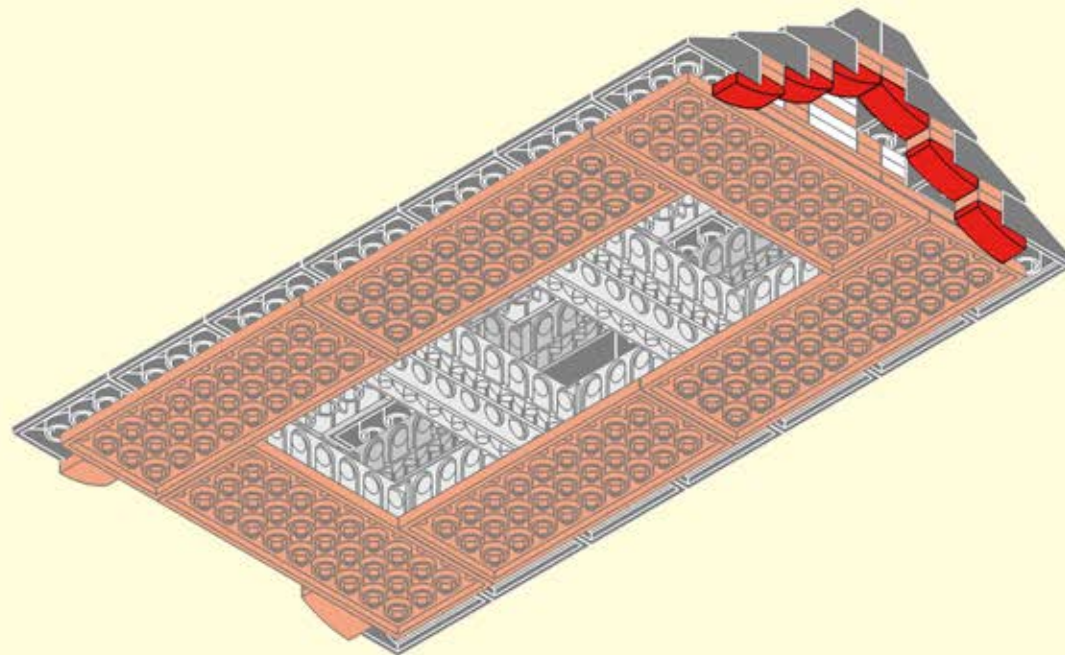

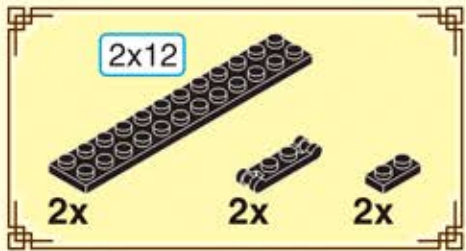

6-14

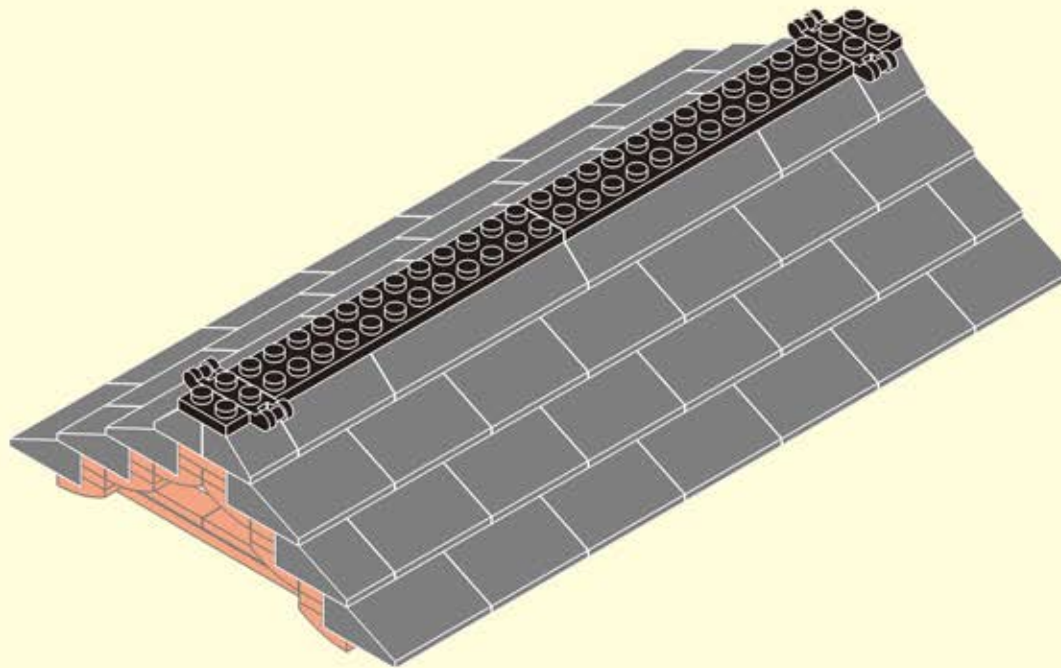

6-15

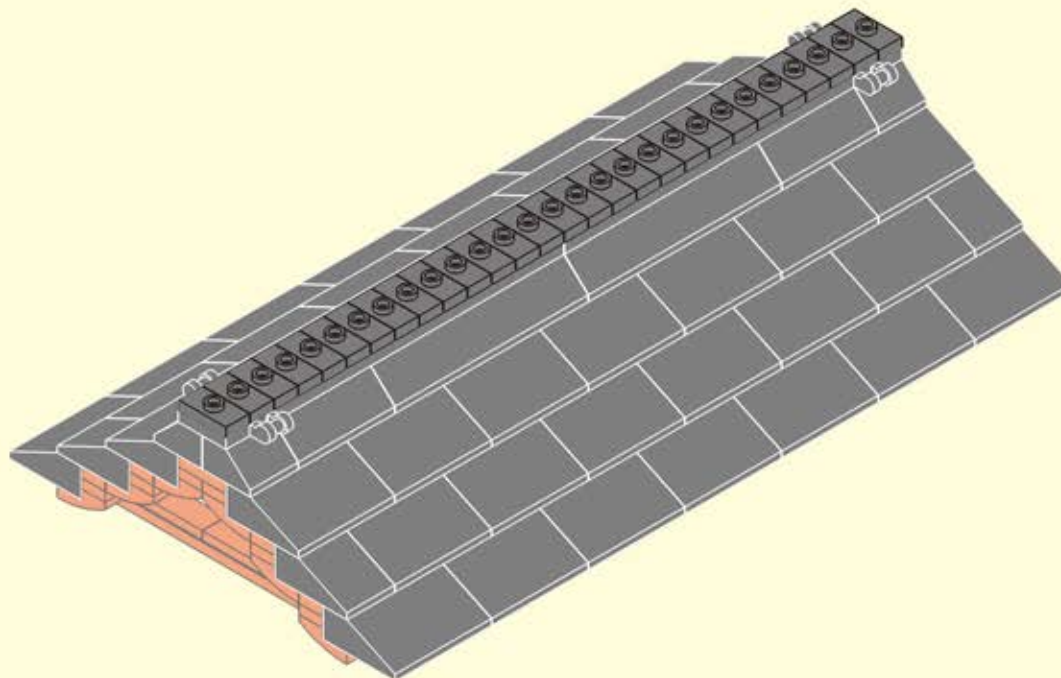



6-16

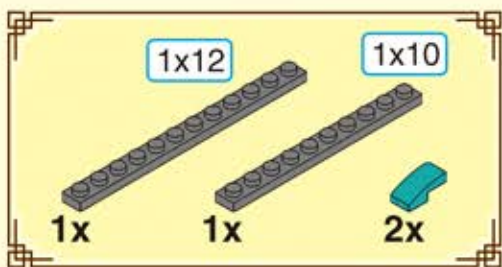
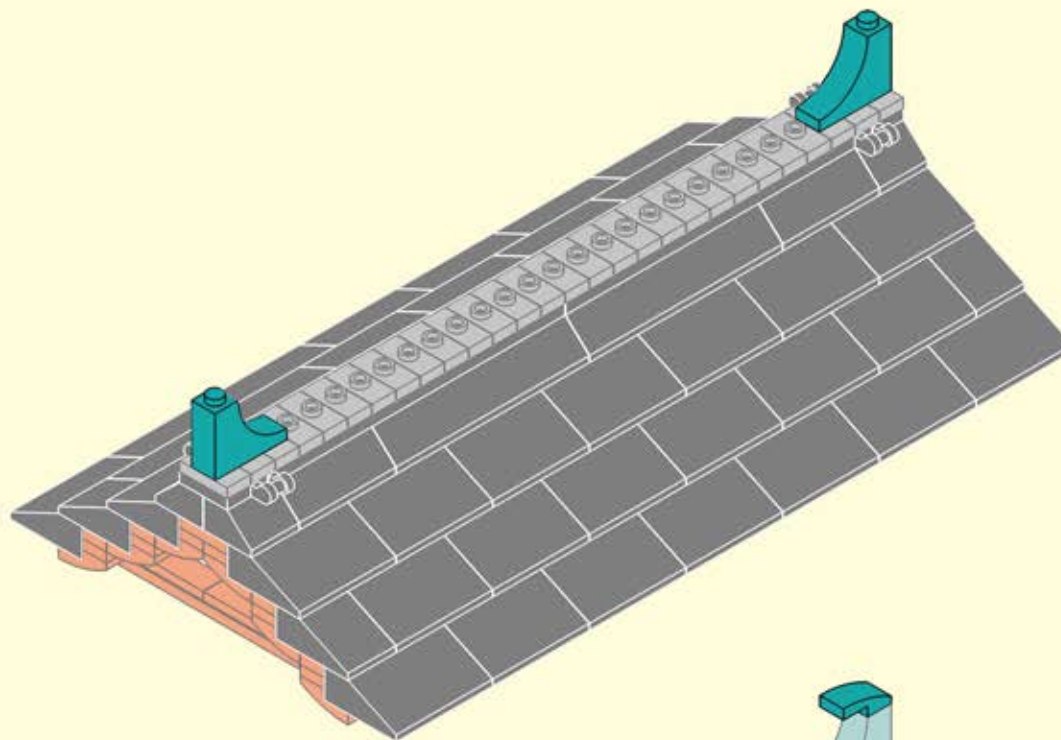

6-17

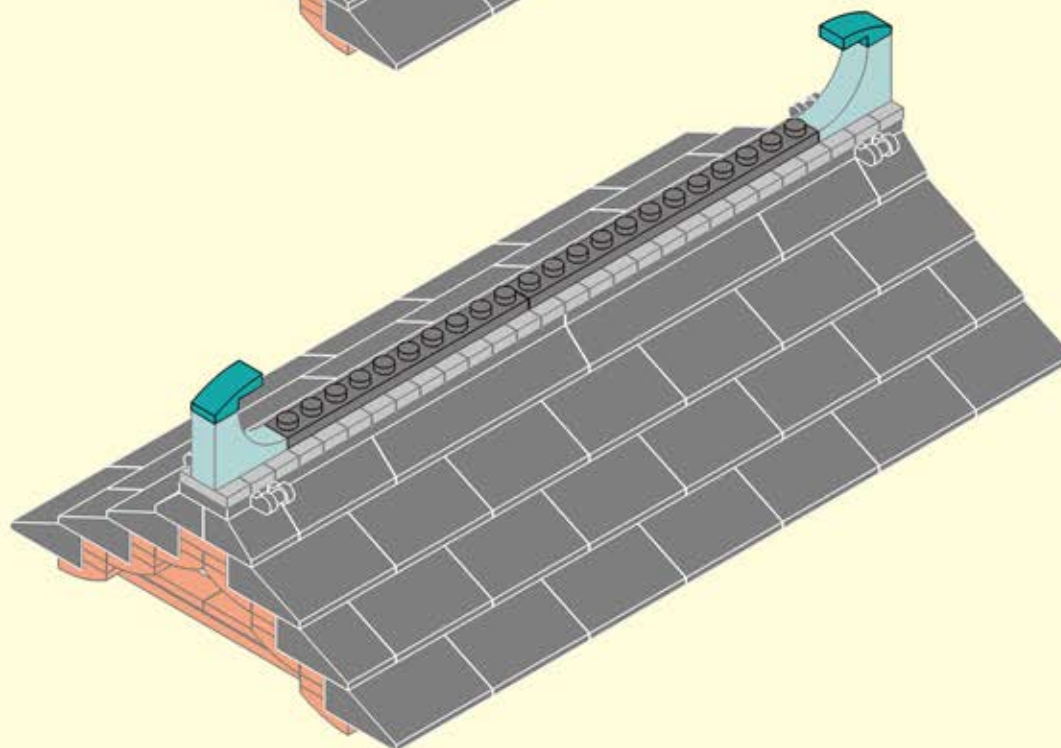

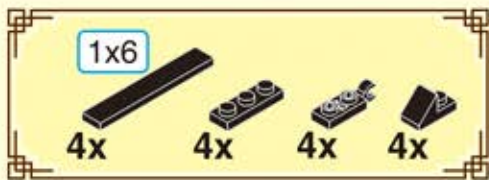

6-18

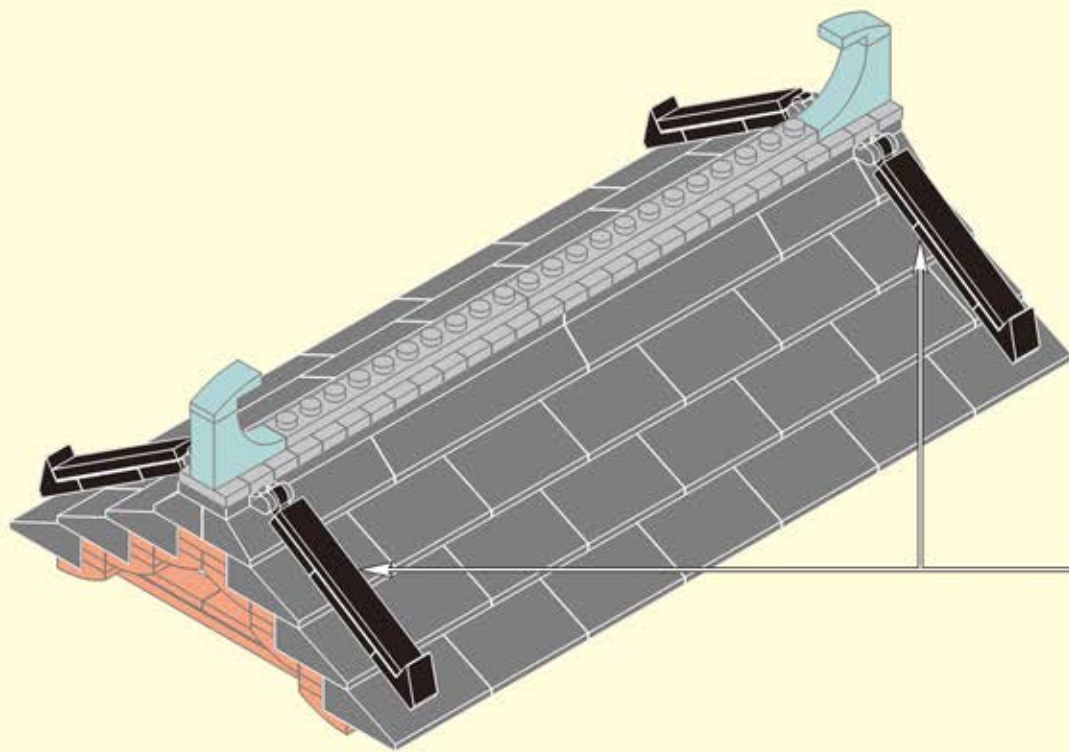

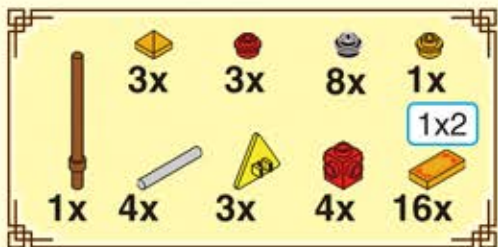

6-19

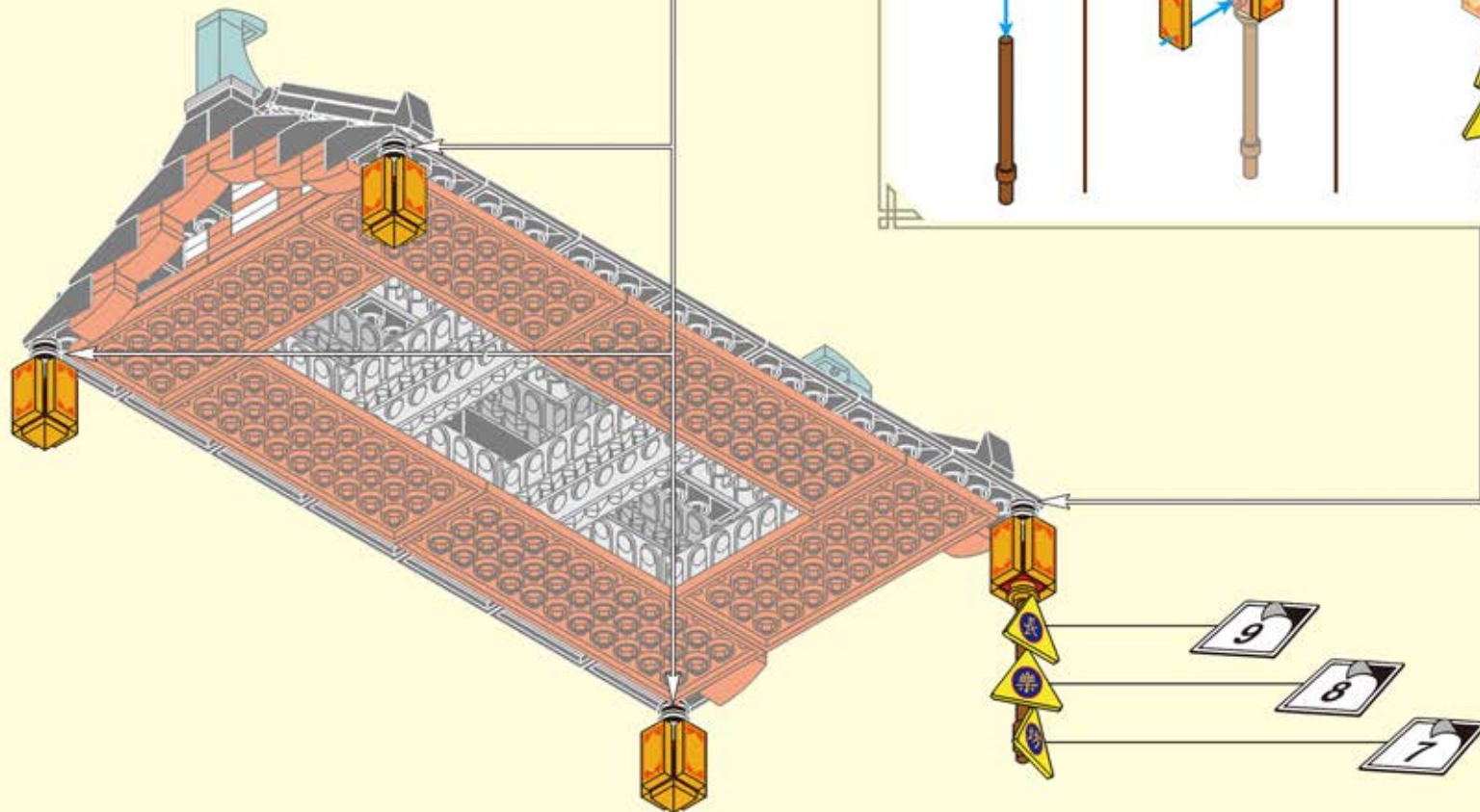
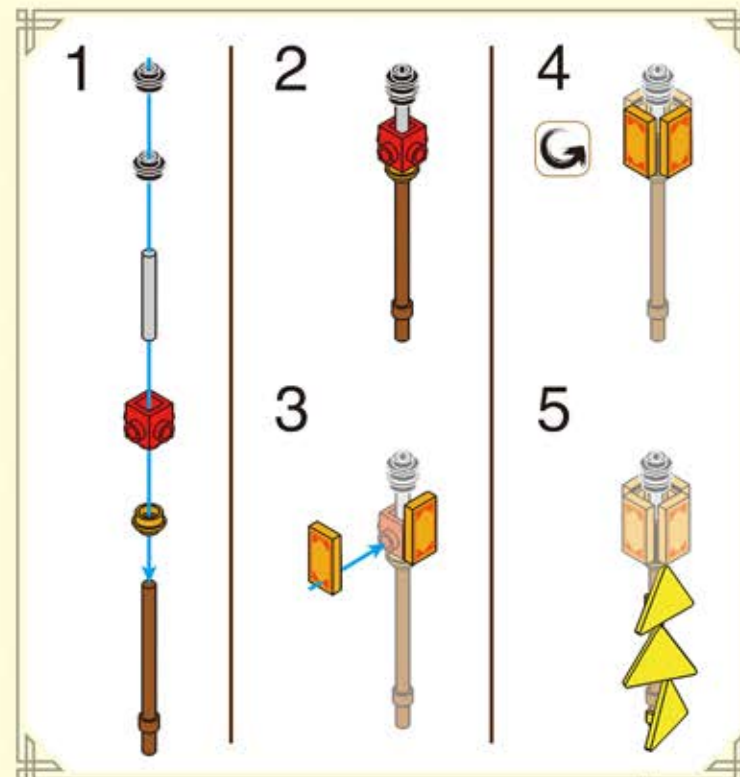
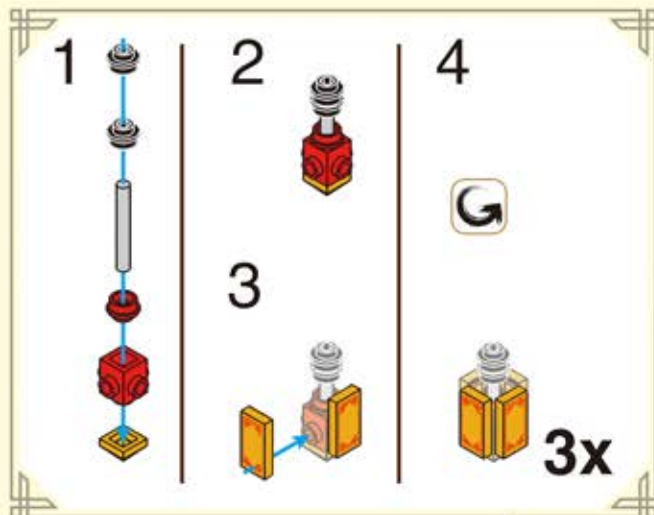

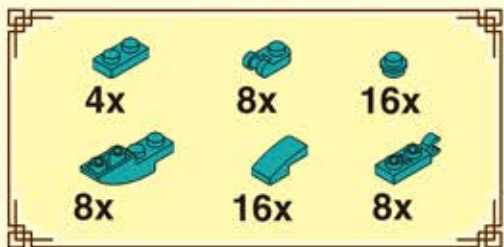

6-20

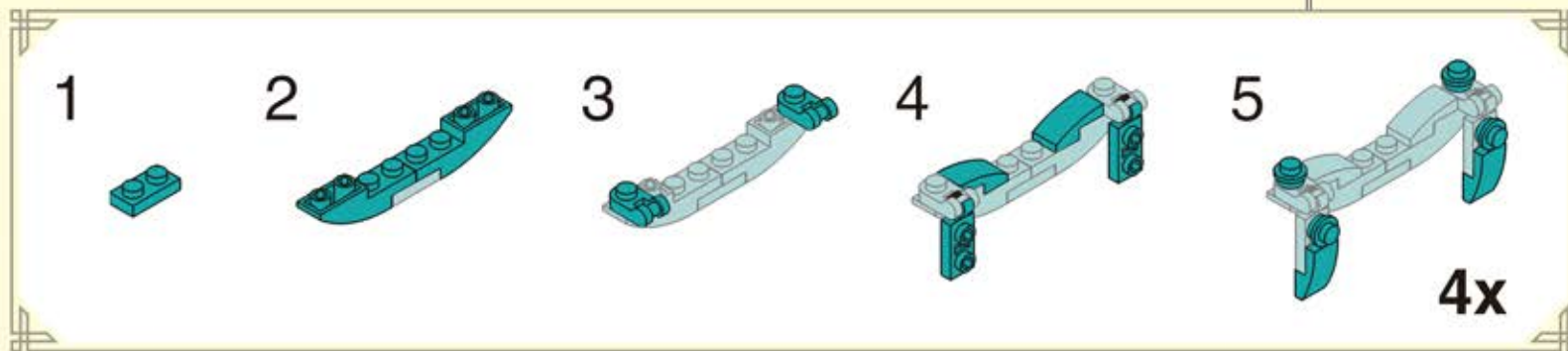
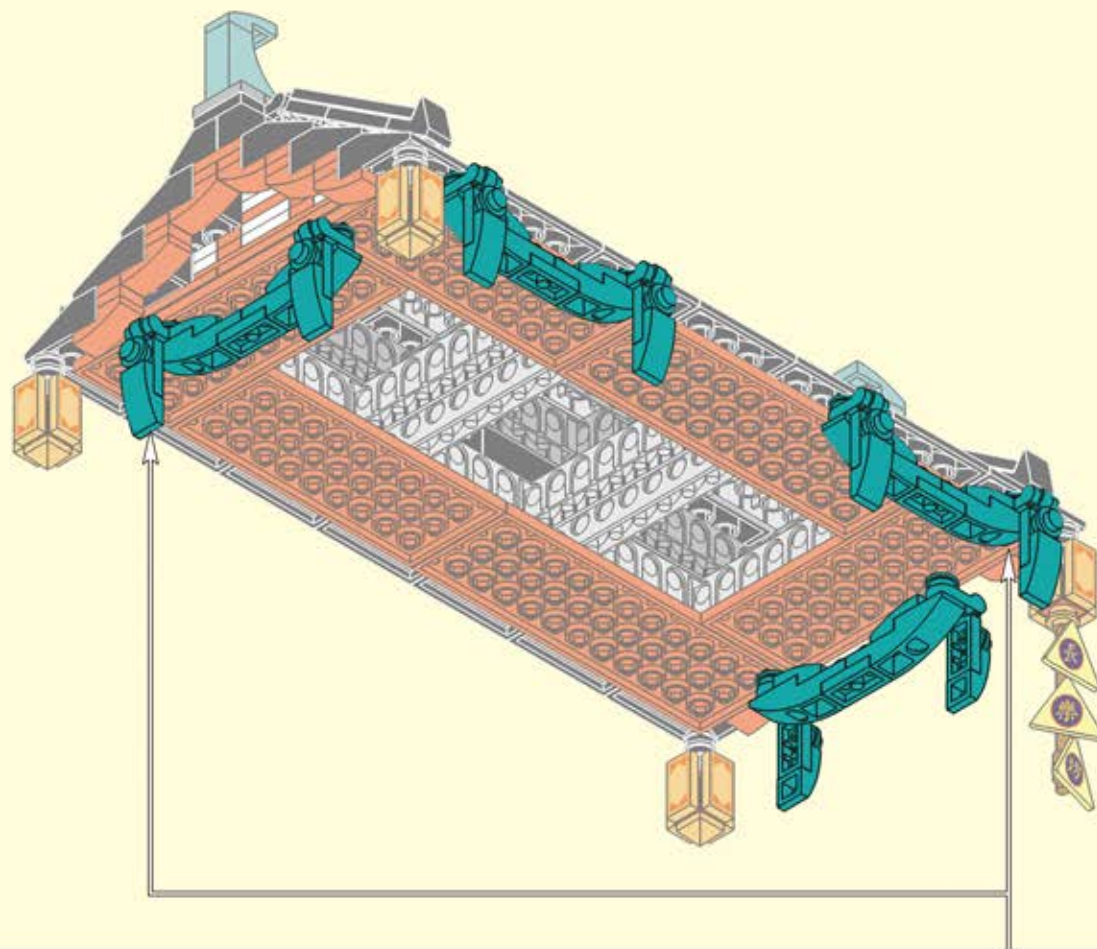

6-21

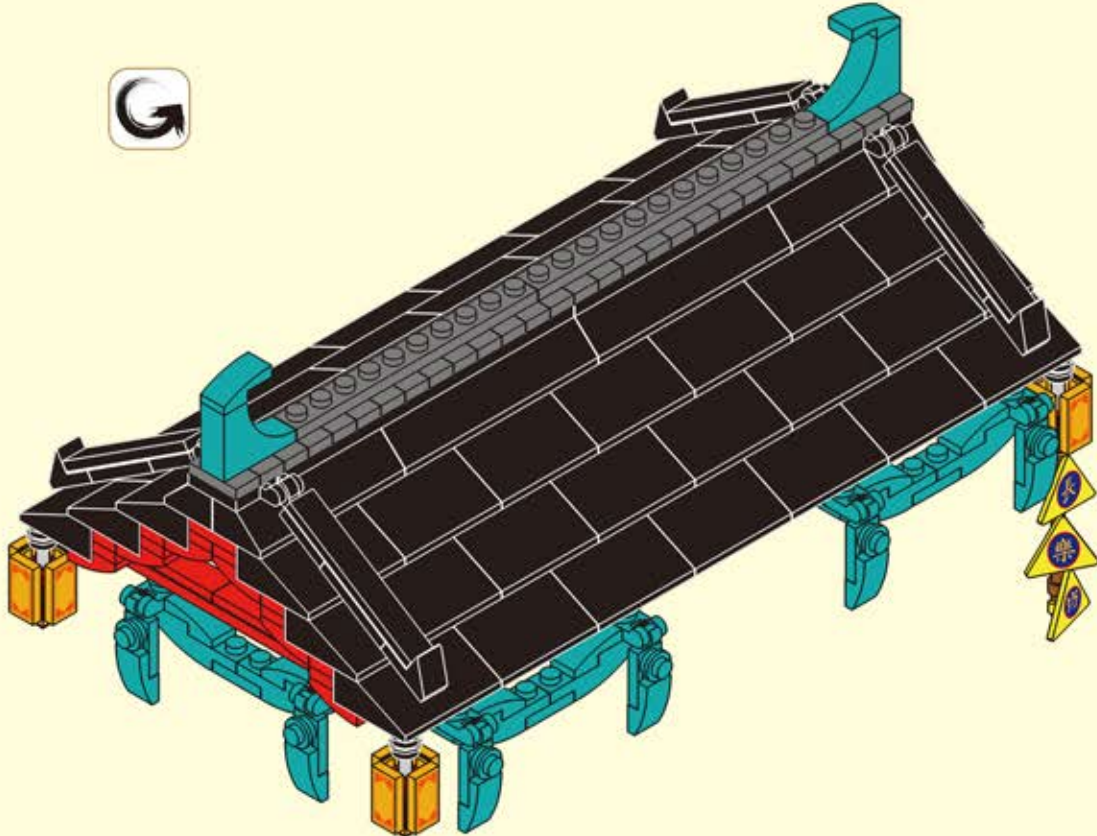

6-22

6-21 

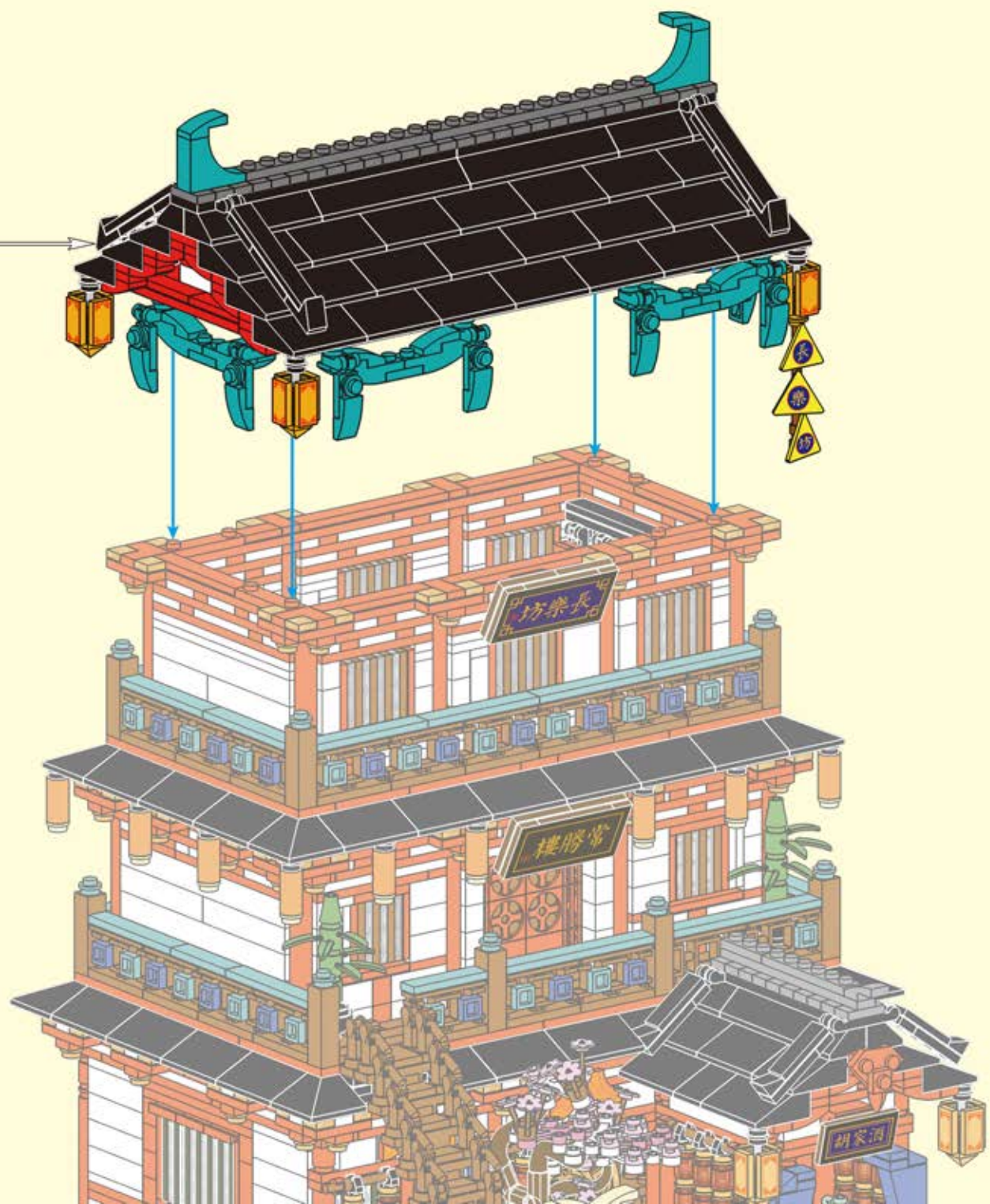



7-1

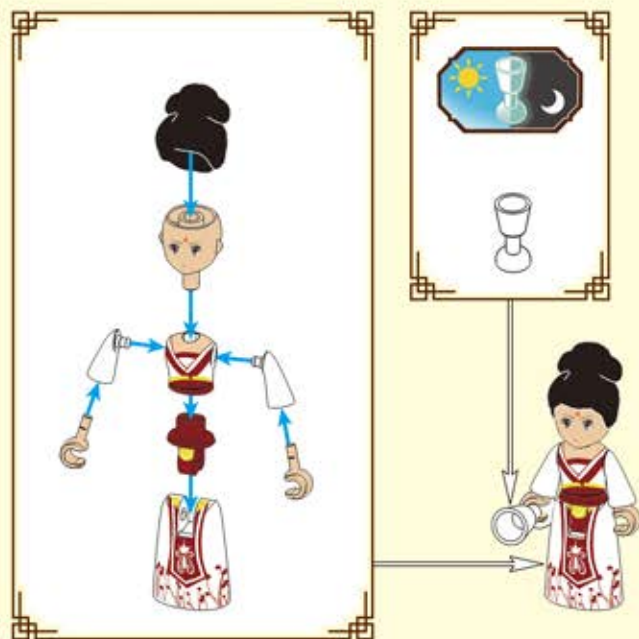

7-2

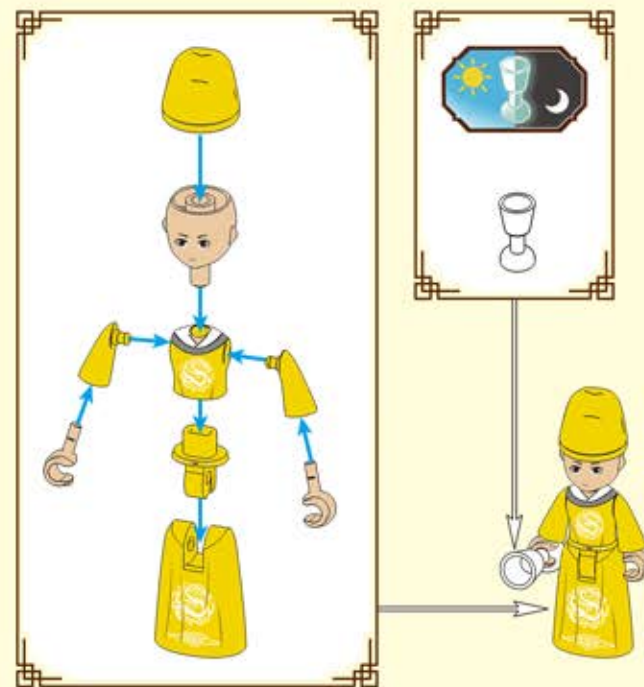

7-3



7-5

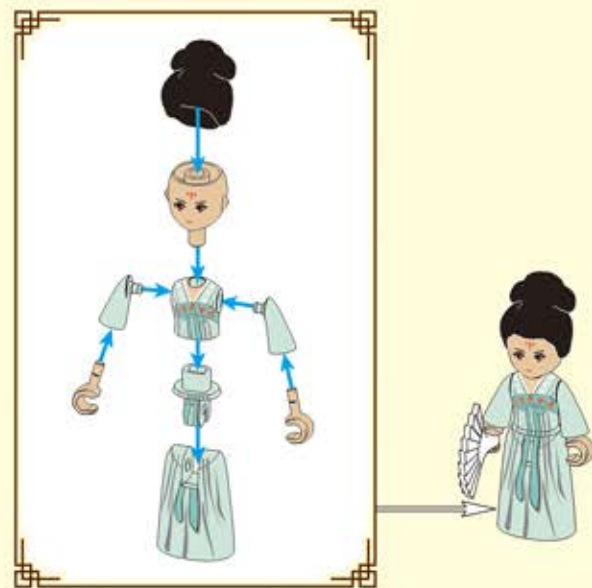

7-4



7-6

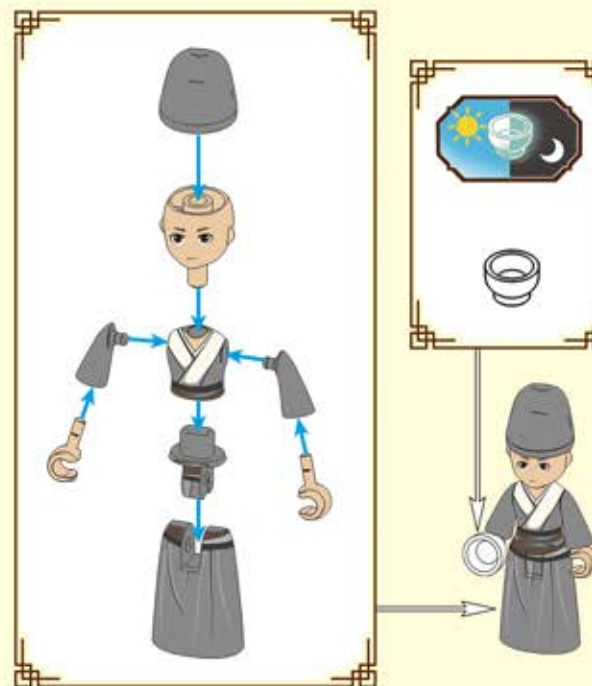



XINGBAO®

星堡积木

01030-2006-V1

