

**MOULD  
KING**

®

# CREATIVE IDEA

## 百变创意

宇 | 星 | 模 | 王

10076

718+ Pcs/Pza



NO. F488  
**拉法488**

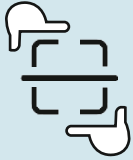

### Qr code APP (APP二维码)

Need the apple version 9.0 and above, the android version 5.0 and above.

\* This APP supports most of the mainstream Android models on the market, but due to the large number of Android models, different models of systems and hardware reasons, there may be some models do not support, specific according to the actual test!



广东宇星科技  
Mould King



产品资讯  
Product Information



售后服务  
After-sales Service

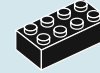

积木补件  
Brick Replacement Service

Customer Service  
客户服务



[www.yx-mk.com](http://www.yx-mk.com)

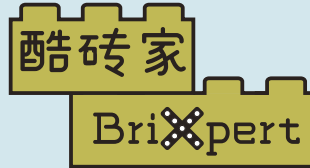

"酷砖家"是宇星模王设立的特殊标识，代表着产品的独特性和原创性。每一款带有"酷砖家"标志的积木套装，都由宇星的原创团队或者与宇星有密切合作的全球顶尖设计师亲自设计或授权。这个标识是我们对消费者的承诺，确保他们可以享受到独一无二且高品质的积木拼搭体验。

"Bri X pert" is a special mark established by MOULD KING, representing the uniqueness and originality of the product. Every building set with the "Bri X pert" logo is personally designed or authorized by MOULD KING's innovative team or world-class designers who work closely with MOULD KING. This logo is our commitment to consumers, ensuring that they can enjoy a unique and high-quality building experience.

# OPEN

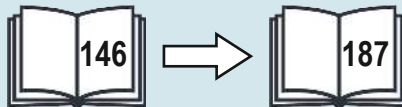
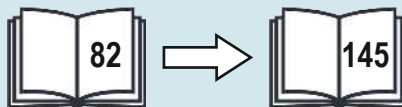
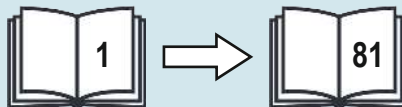

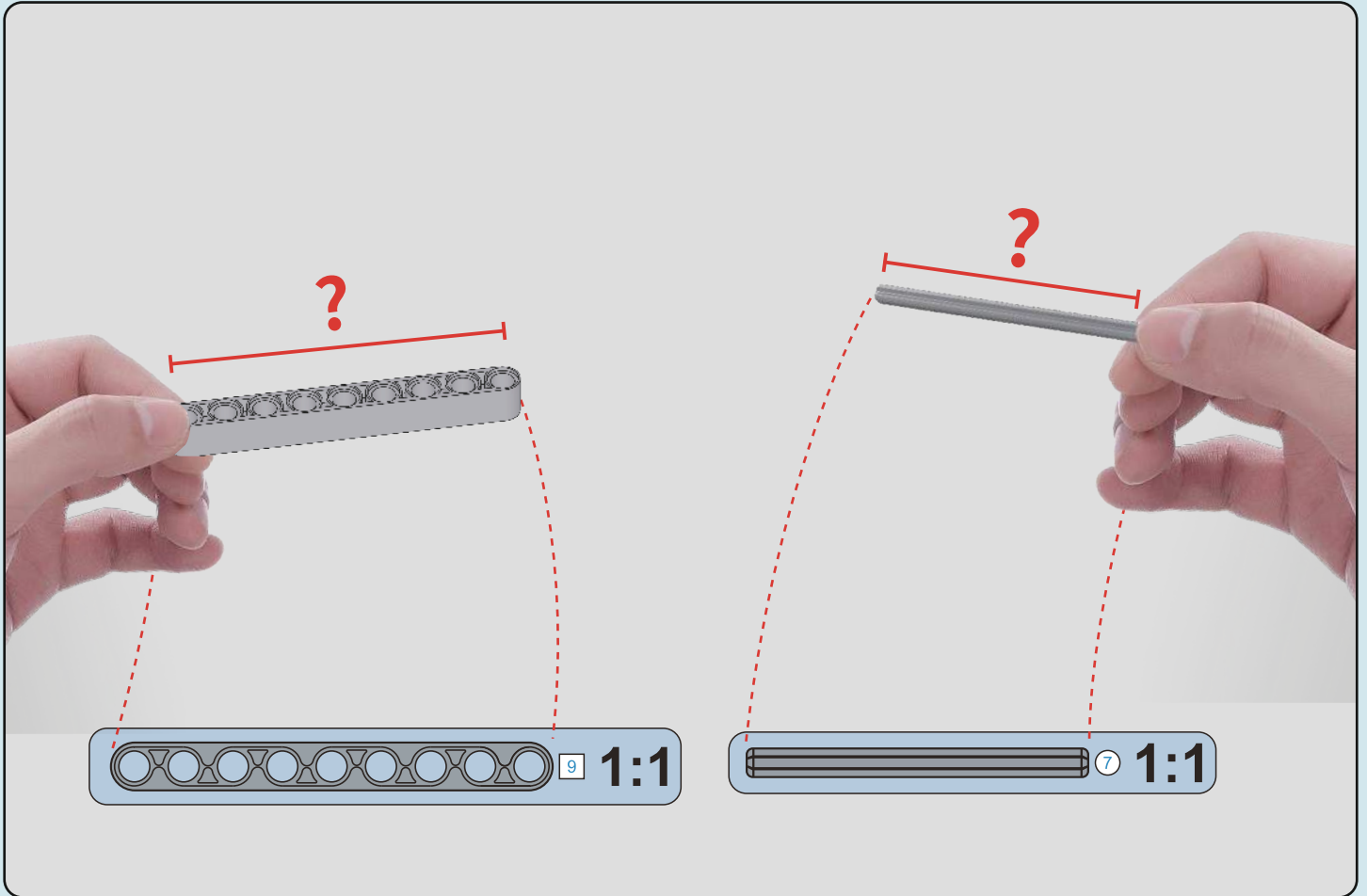

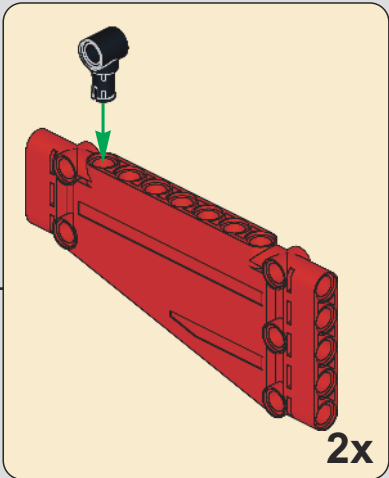
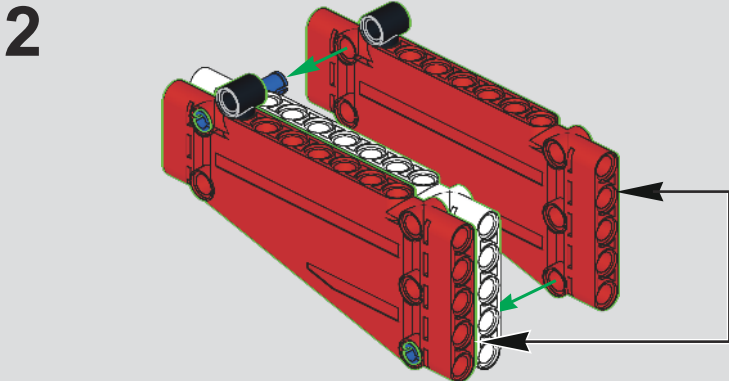
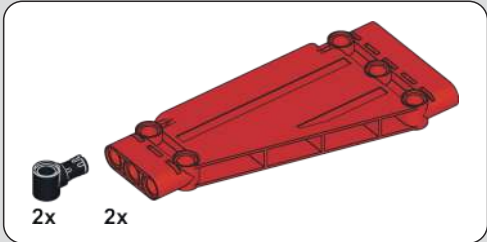
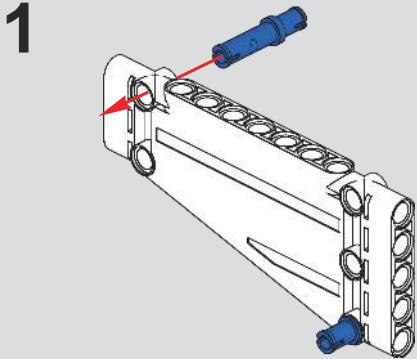
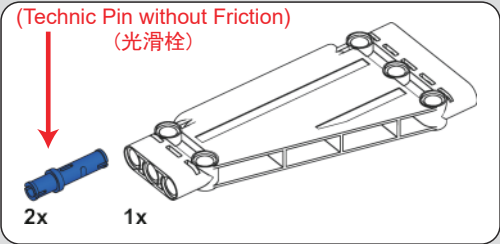

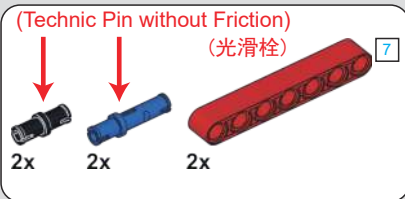

3

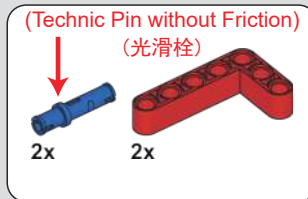
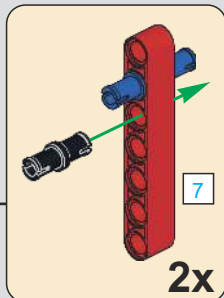
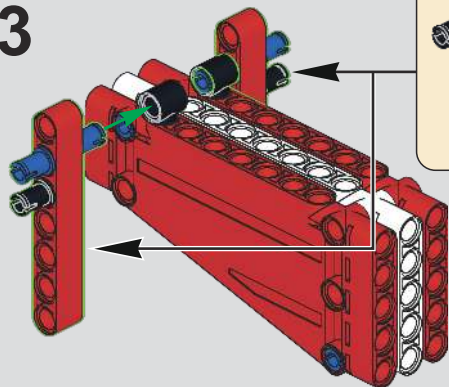

4

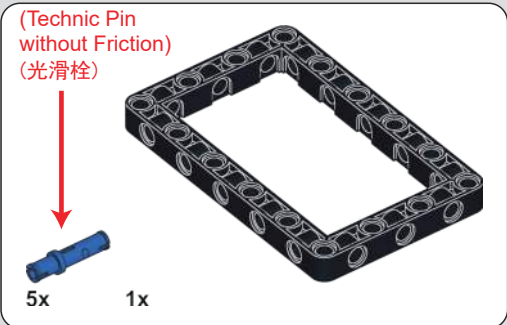
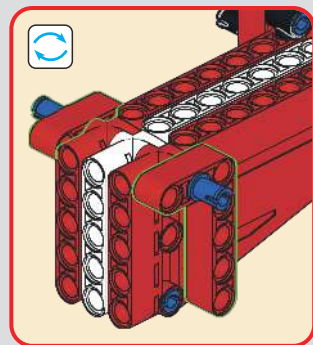
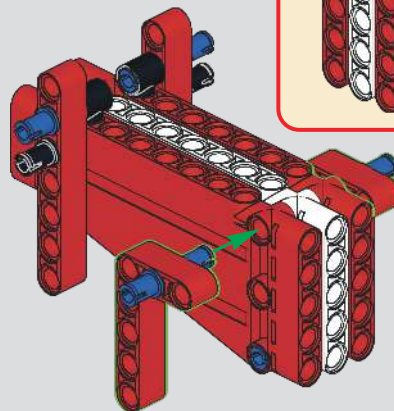

5

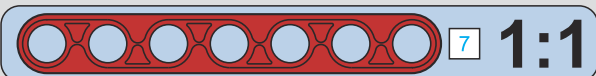
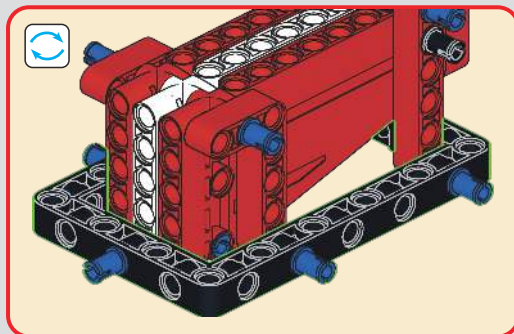
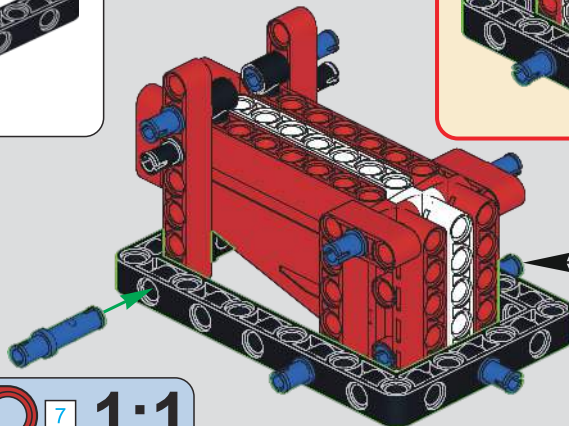

(Technic Pin without Friction)  
(光滑栓)  
↓  
2x 2x 2x

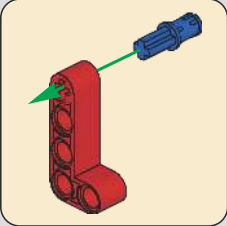

6

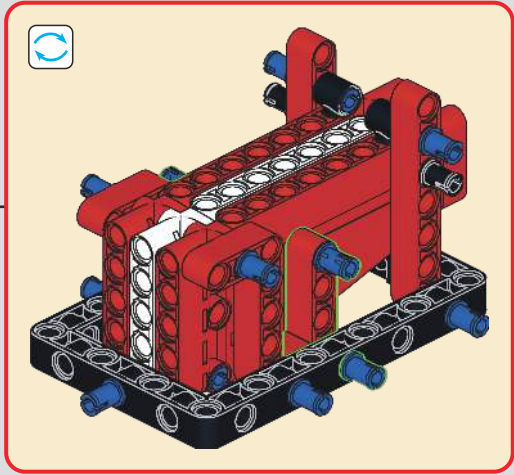
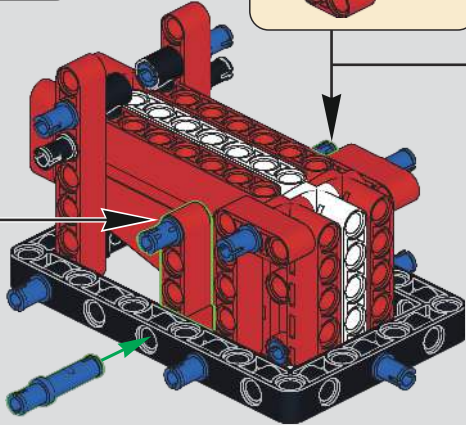
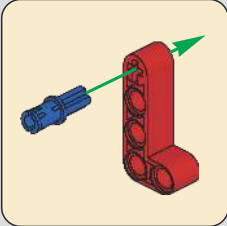

4x 1x  
↑  
(光滑栓)  
(Technic Pin without Friction)

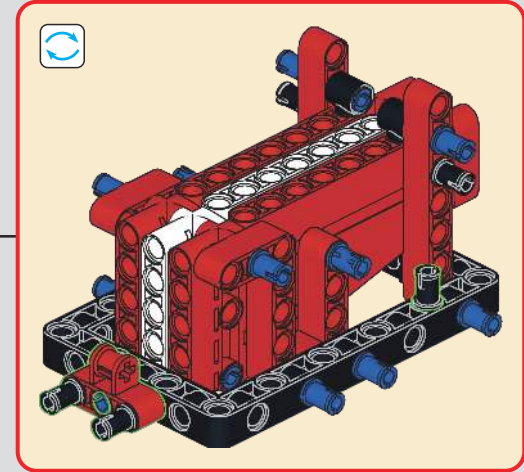

7

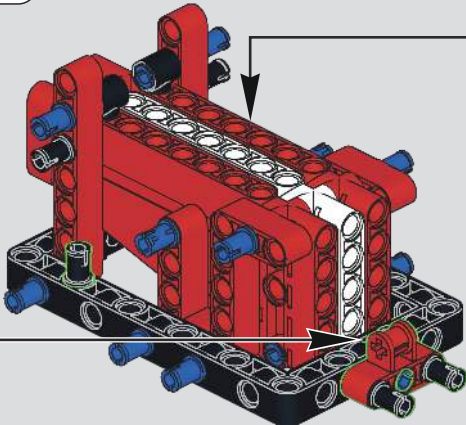
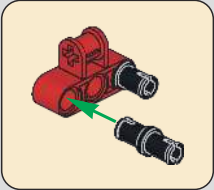

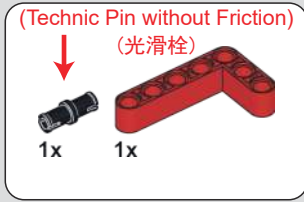
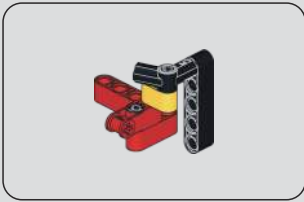

8

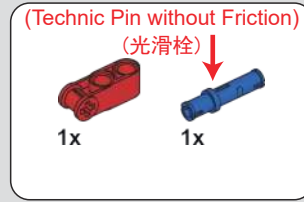

9

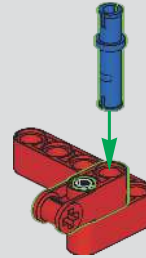
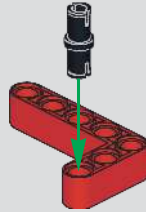
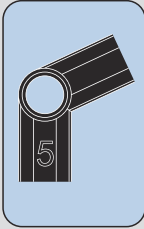

10

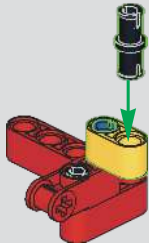

11

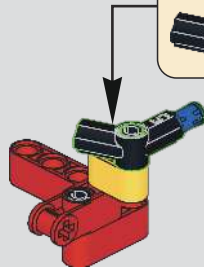
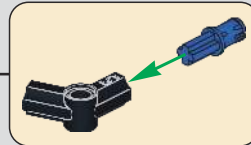

12

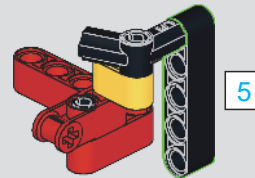

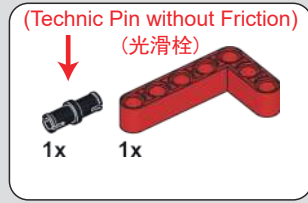
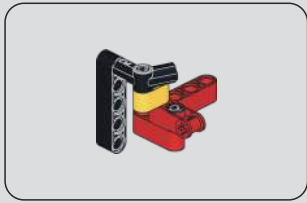

13

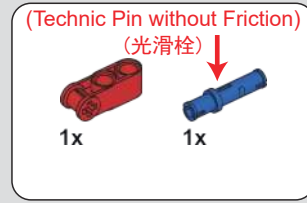

14

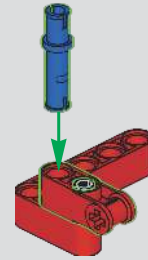
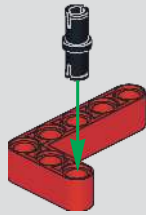
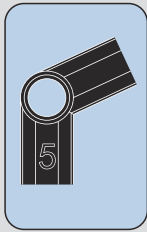

15

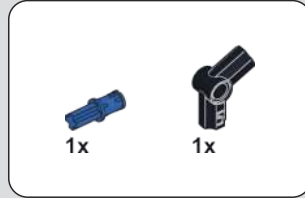

16

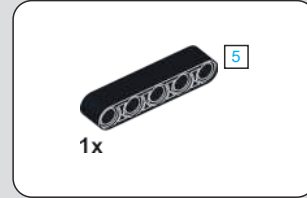

17

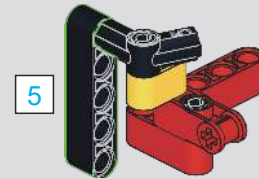
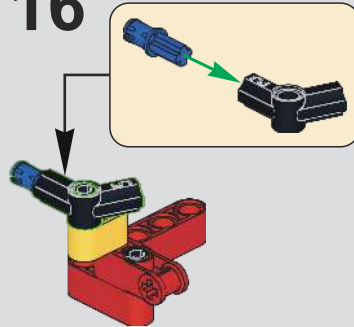
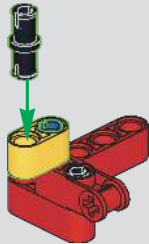



18

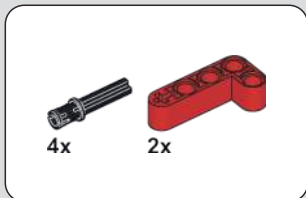
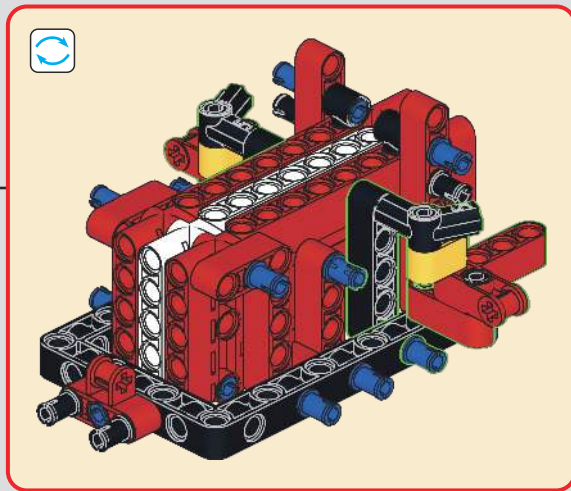
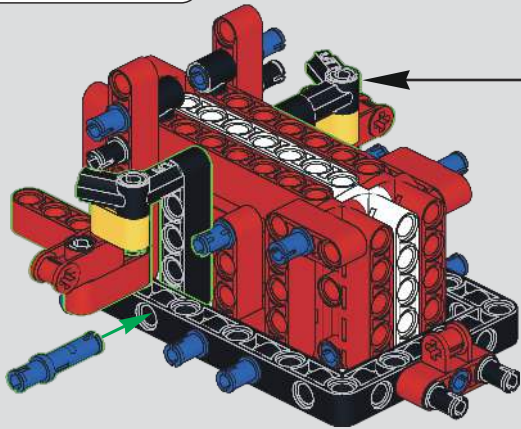

19

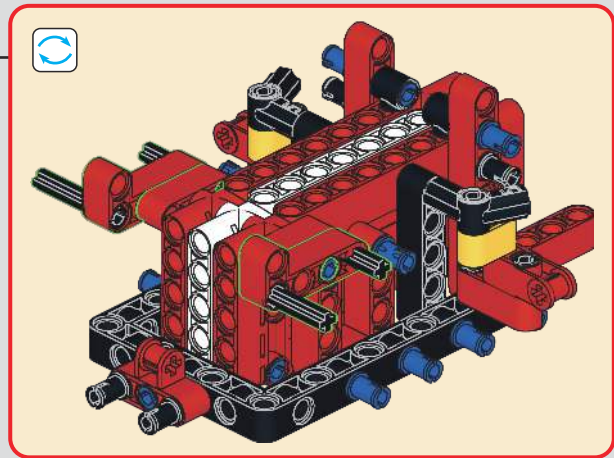
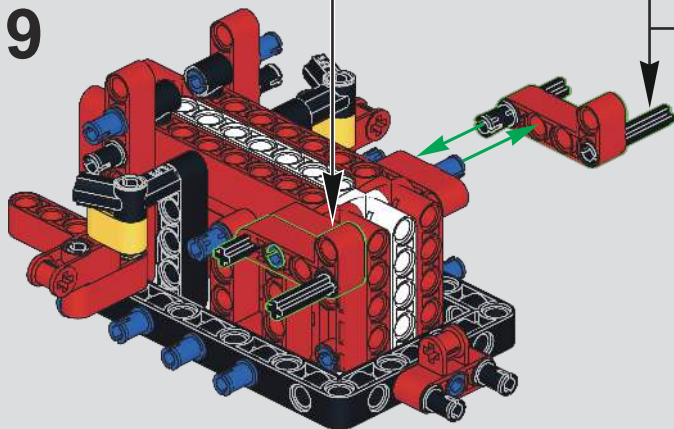

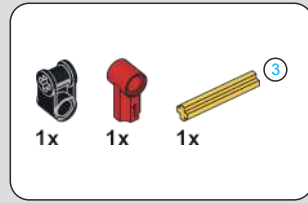
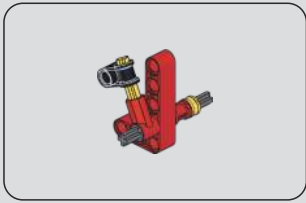

20

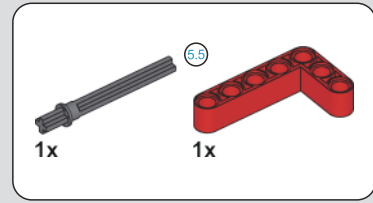

21

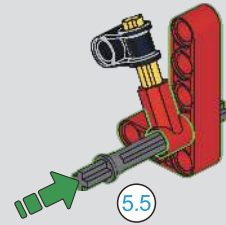

22



23

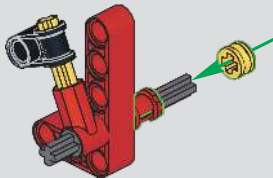
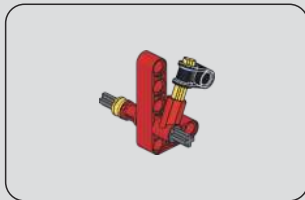

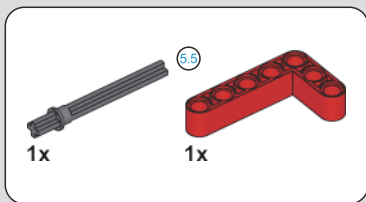

24

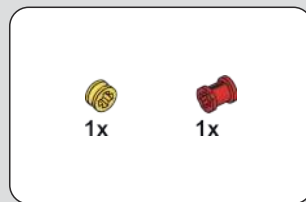
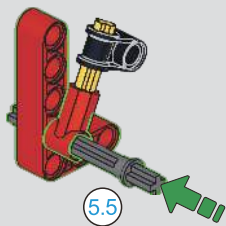

25

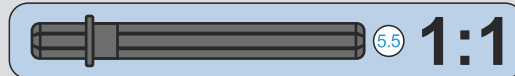
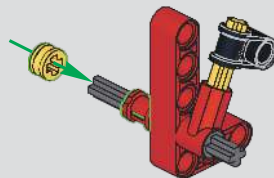

26

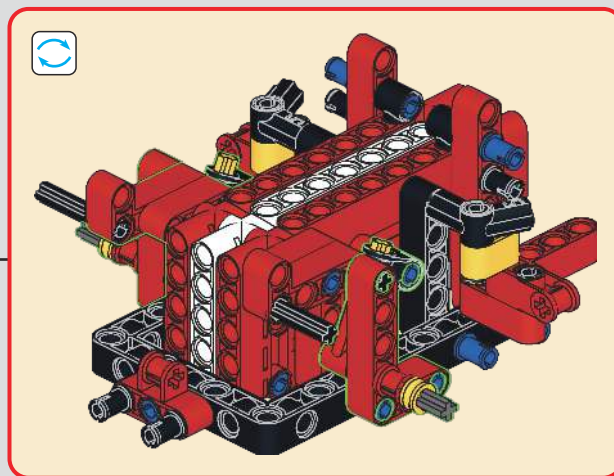
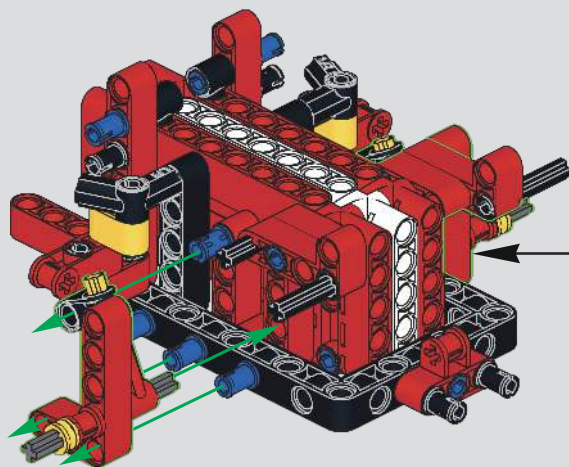

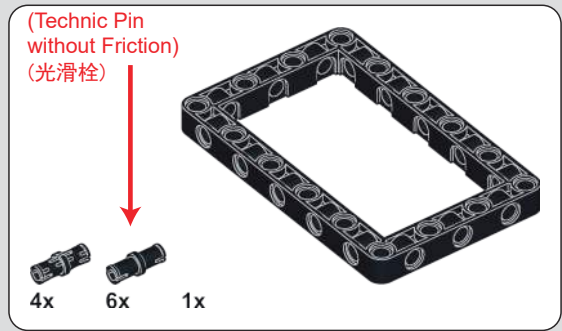

27

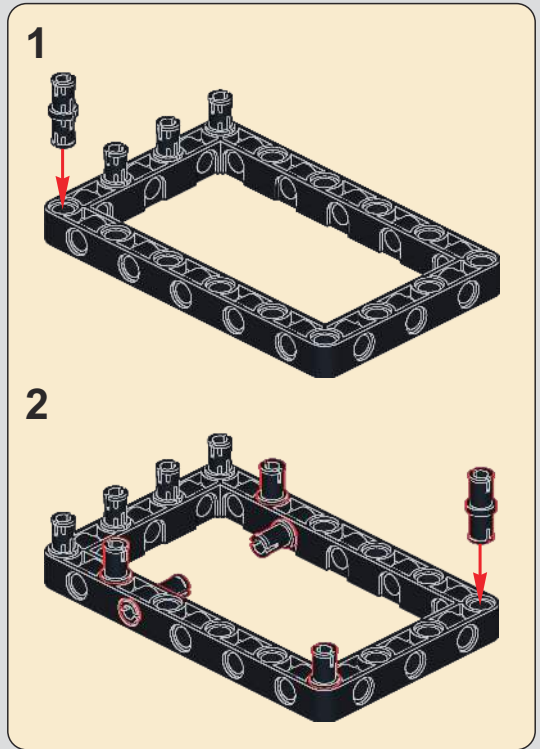
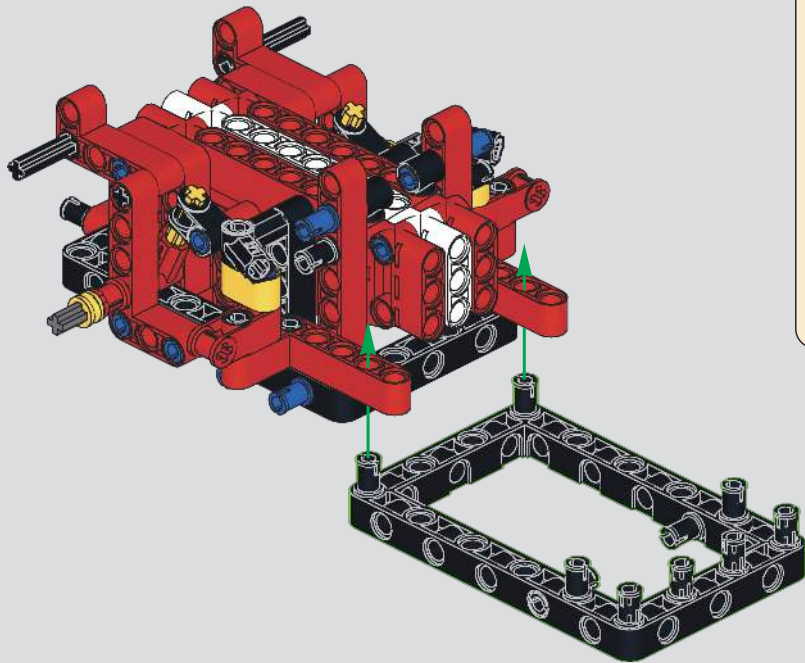



28

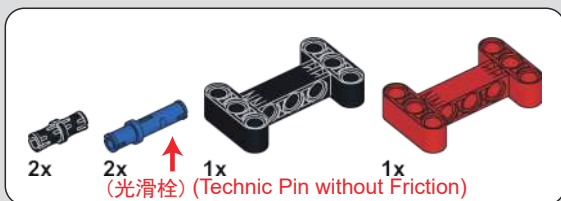
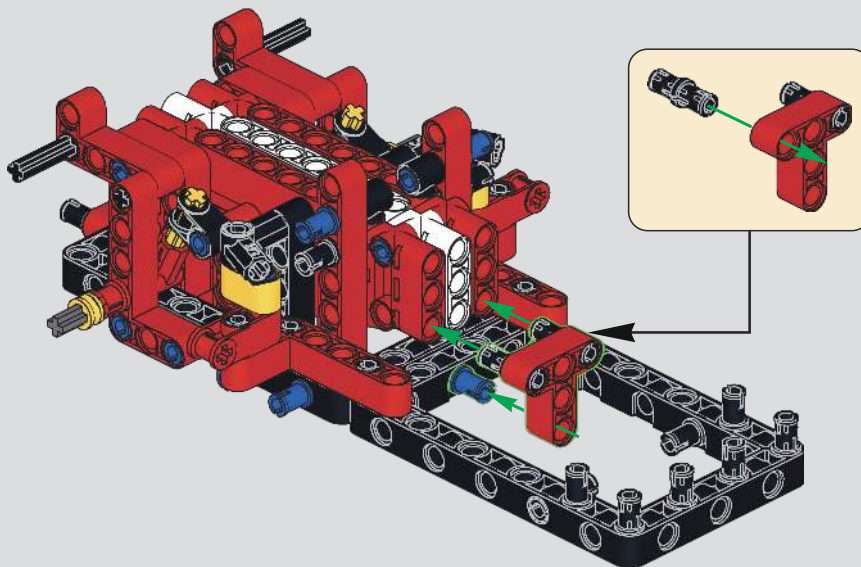

29

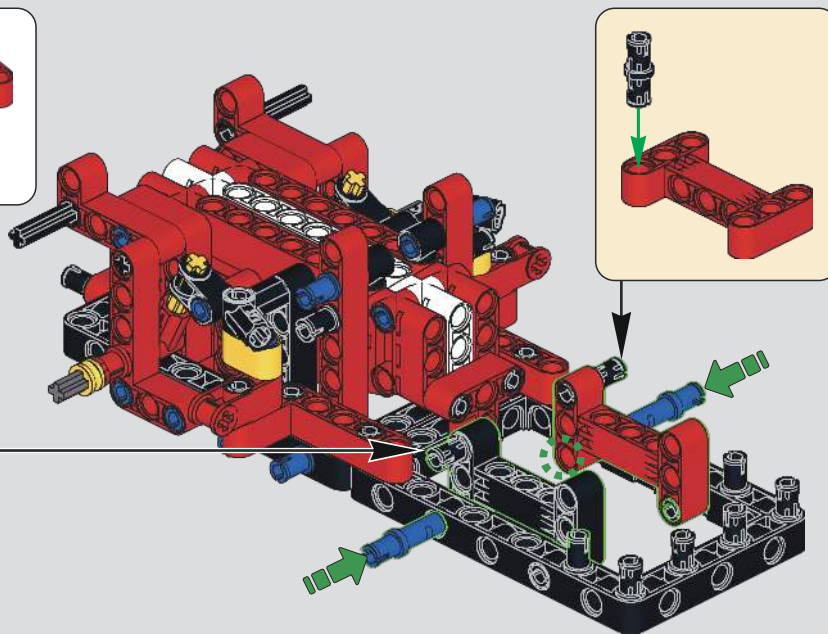
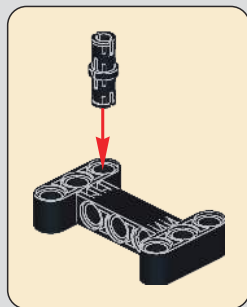

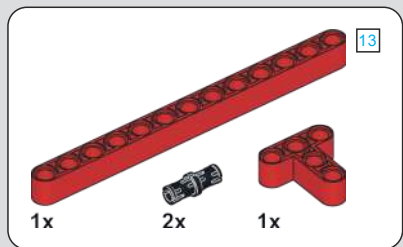

30

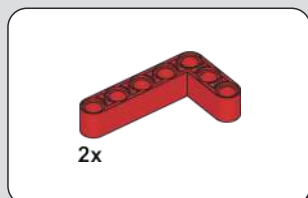
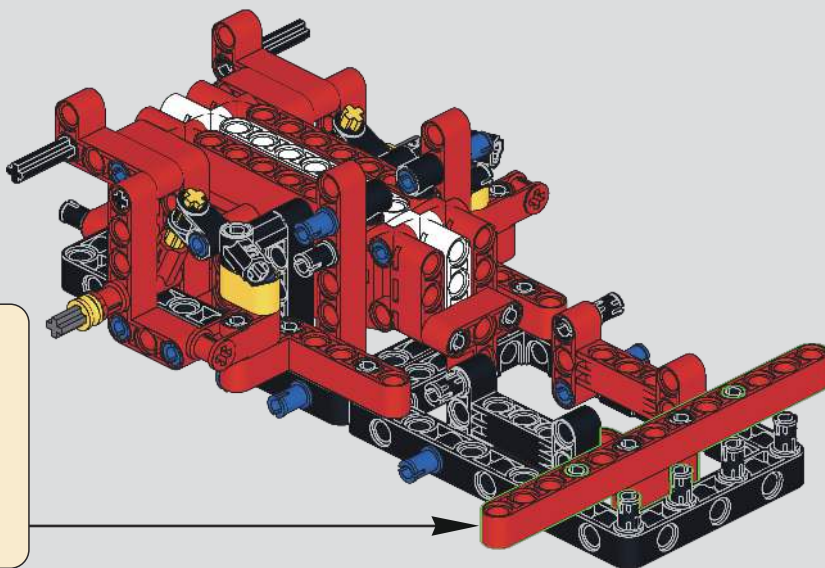
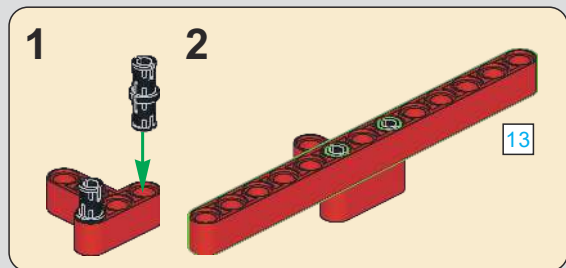

31

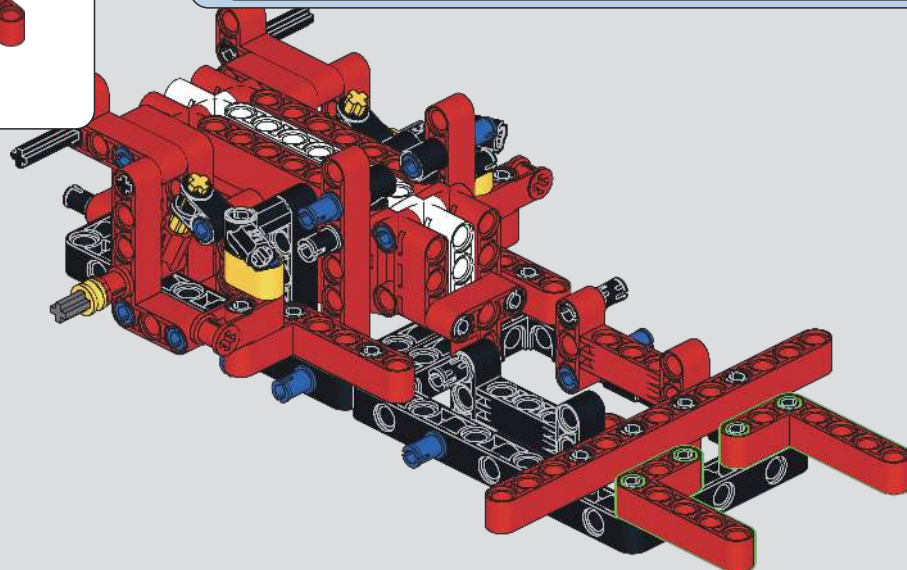
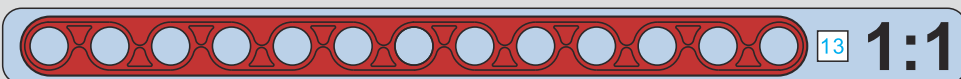



32

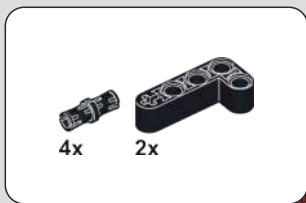
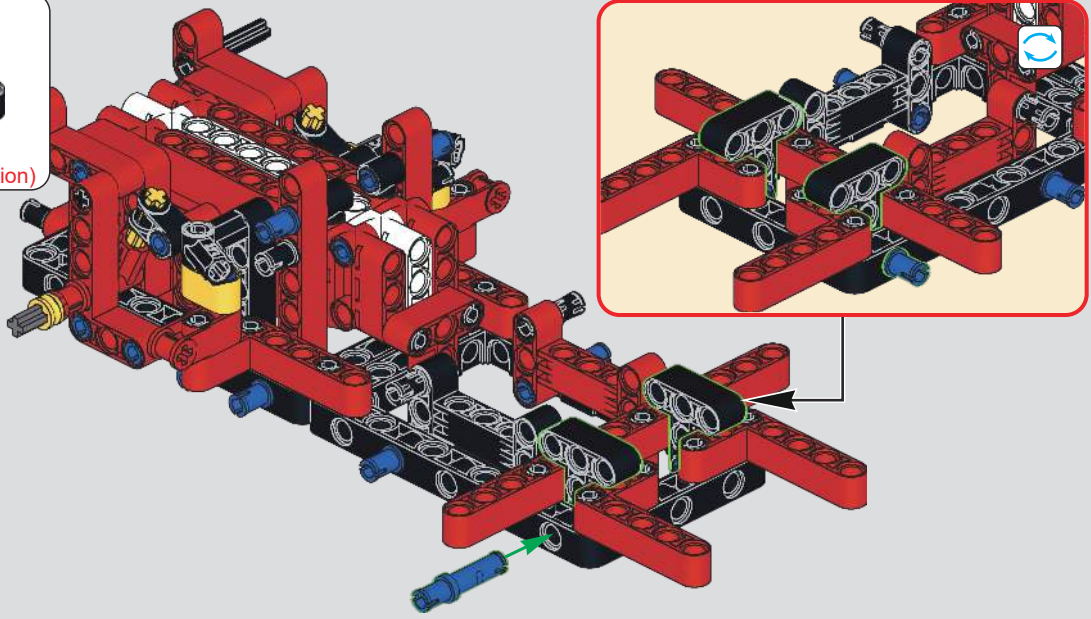

33

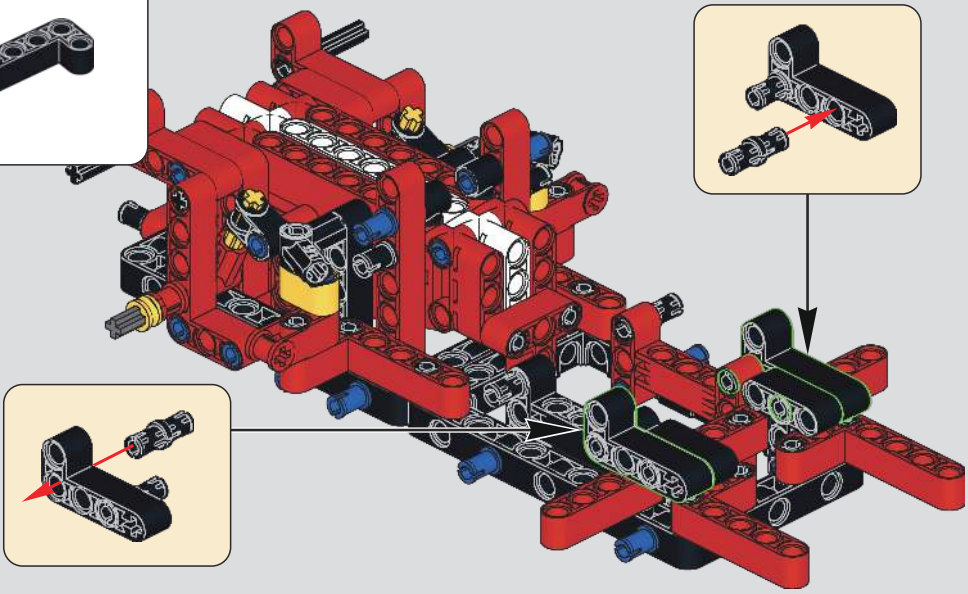

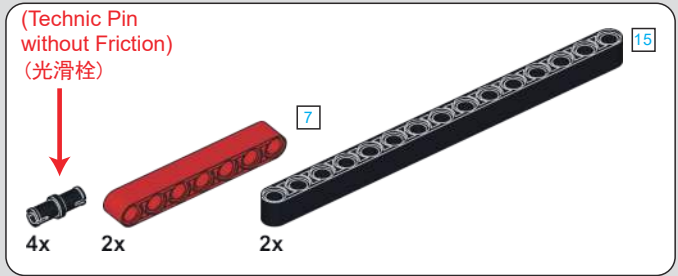

34

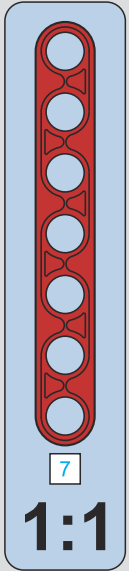
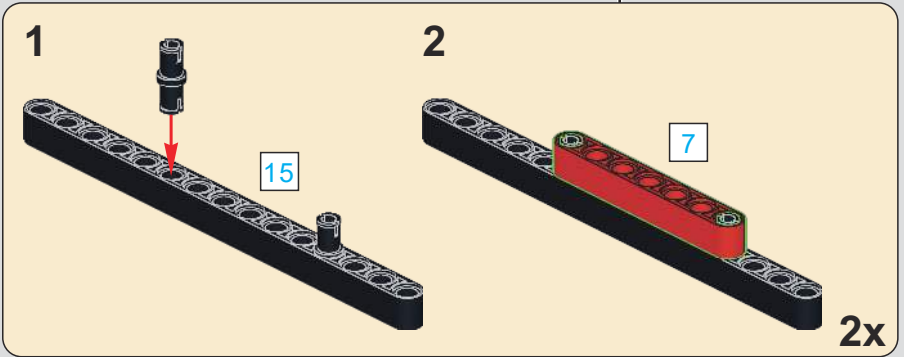
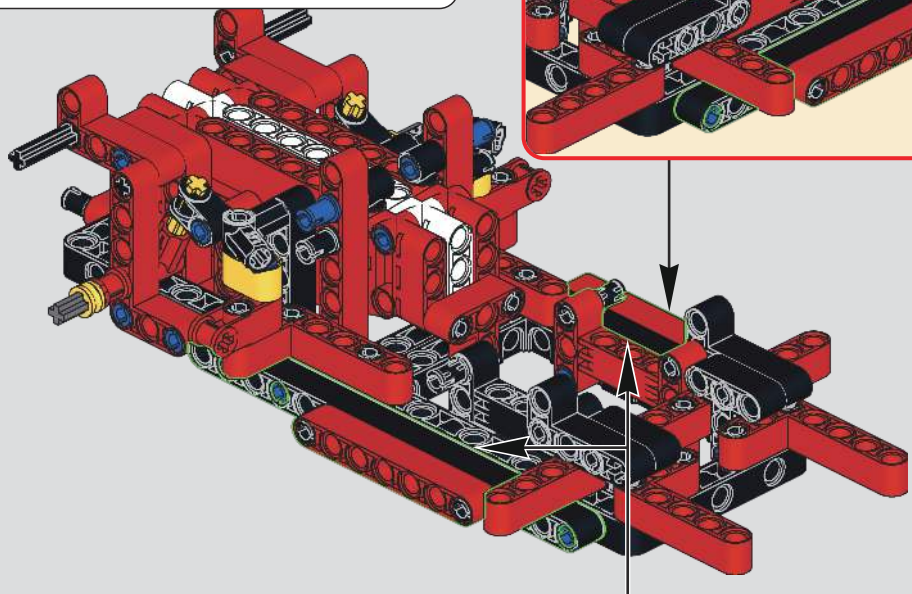
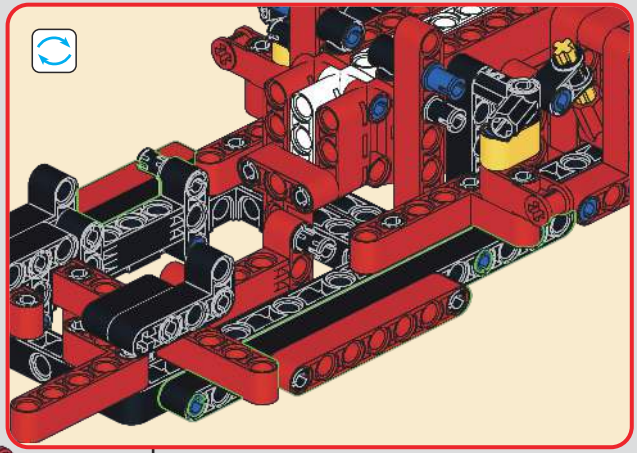

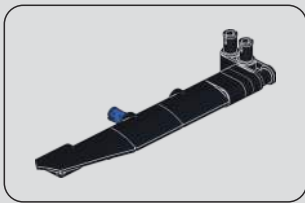

35

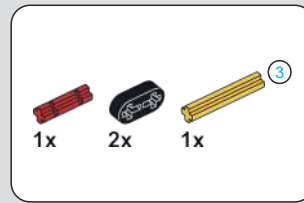

36

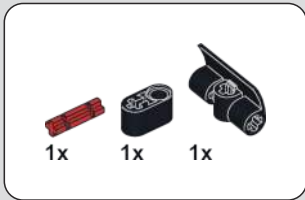
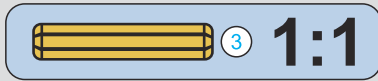
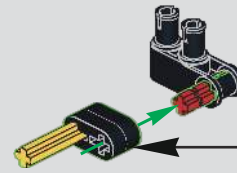
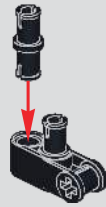
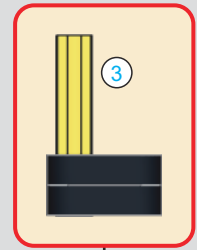

37

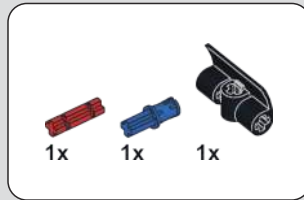

38

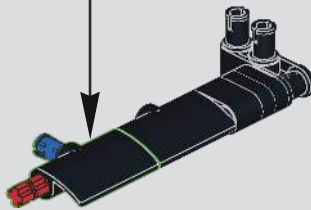
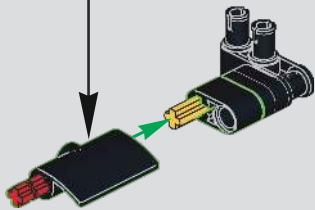
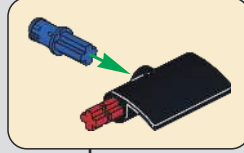
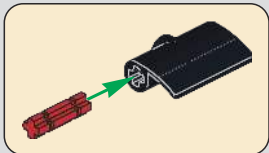

39

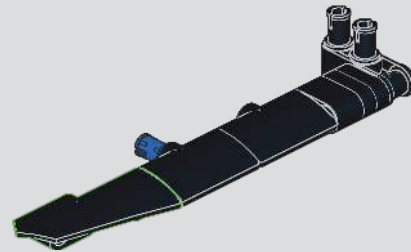



40

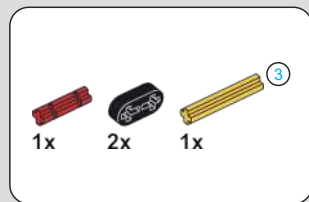

41

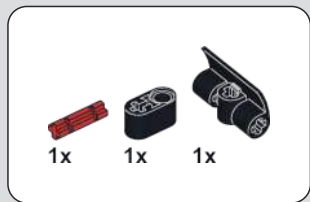
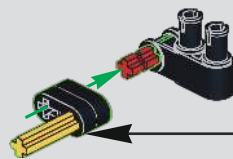
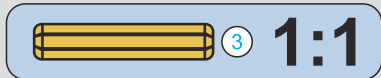
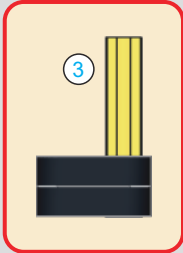

42

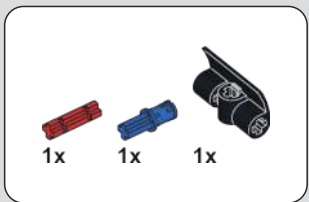
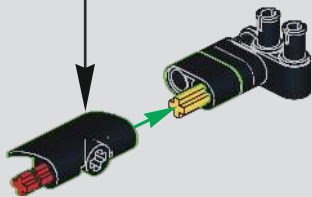
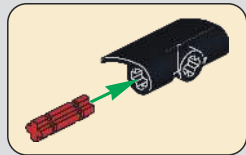

43

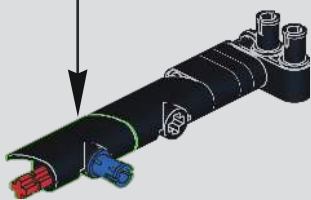
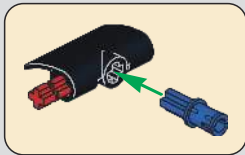

44

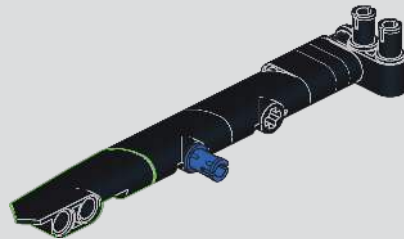

45

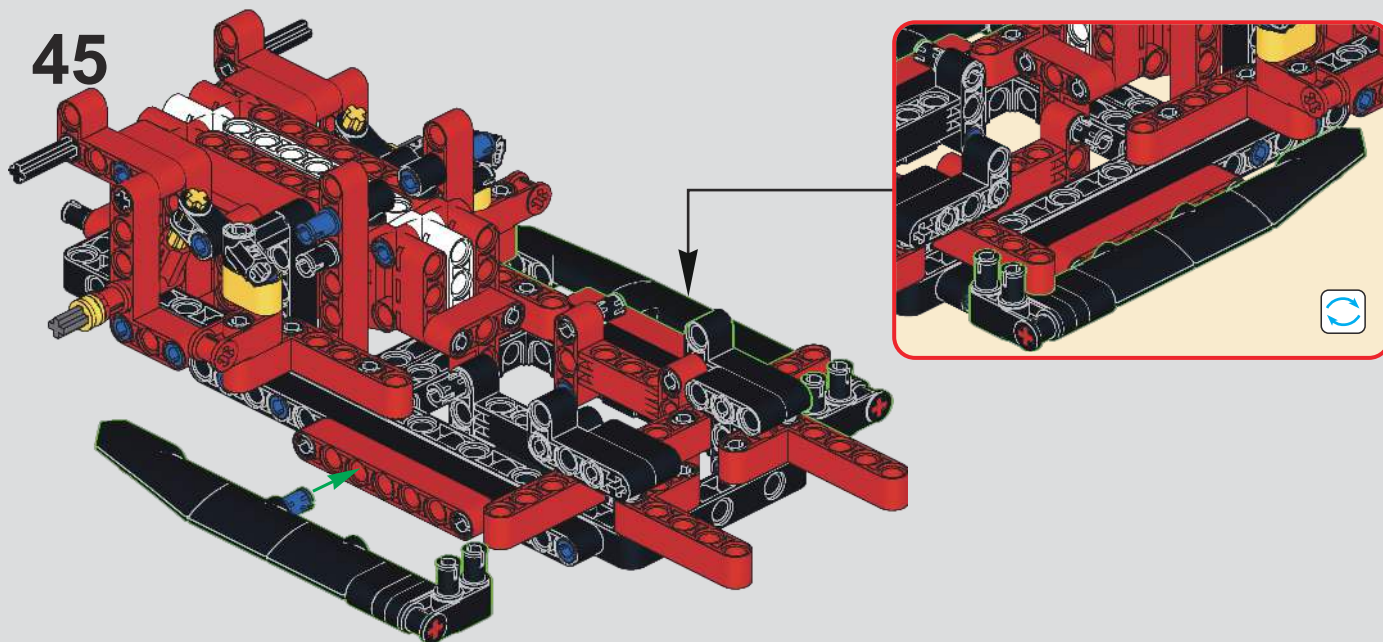

46

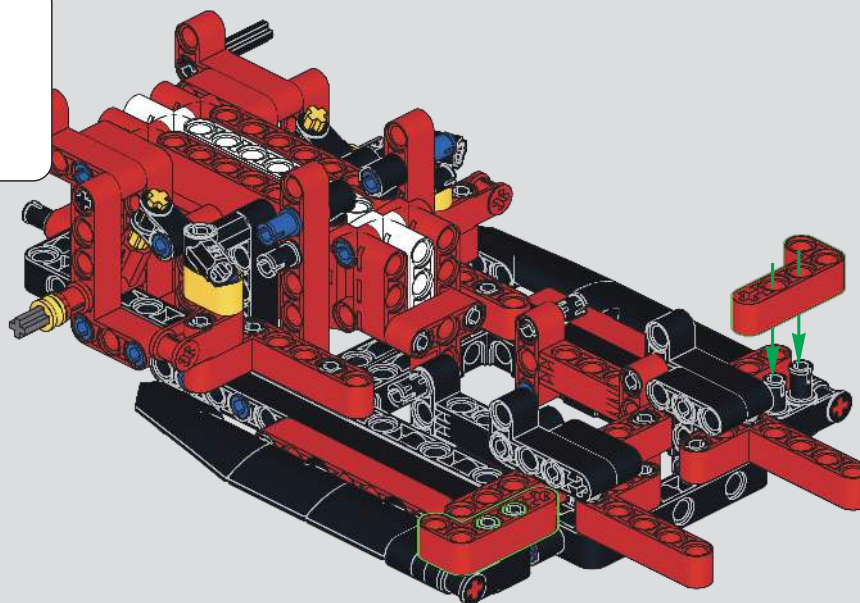
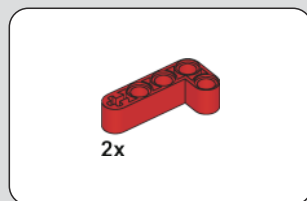

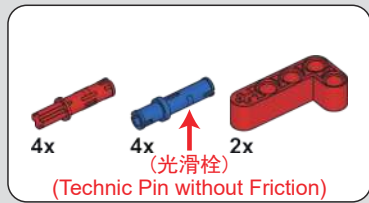

47

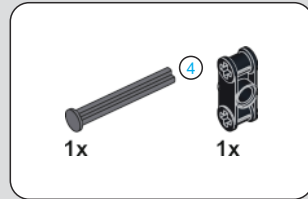
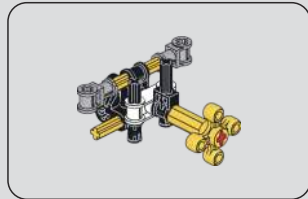
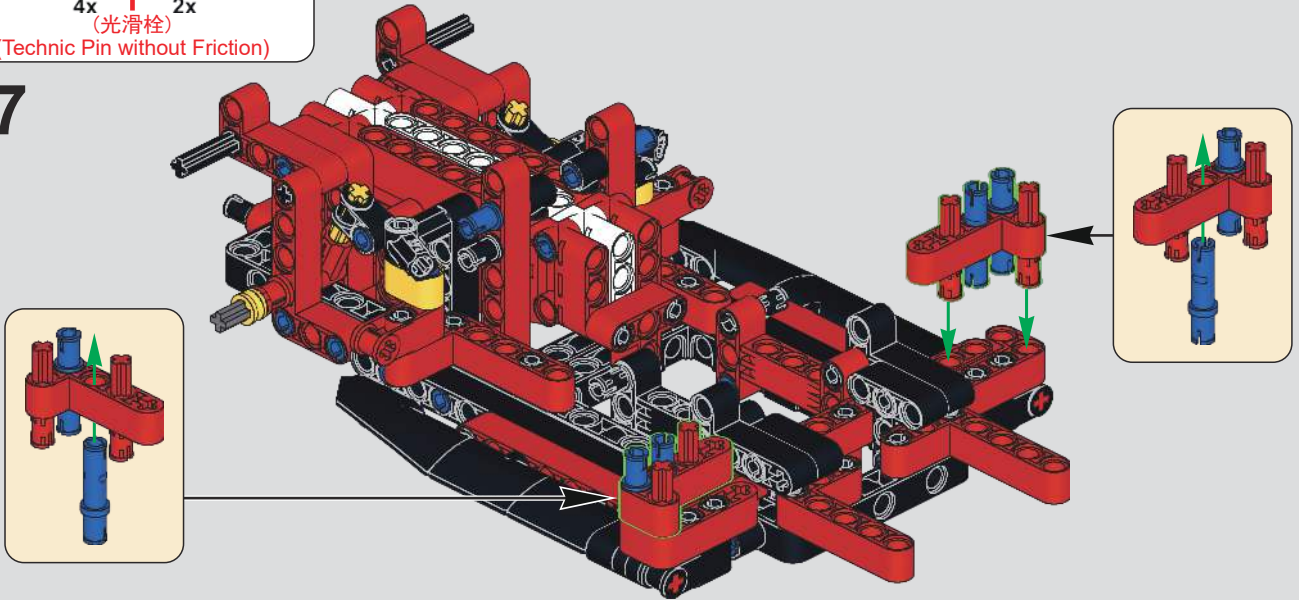

48

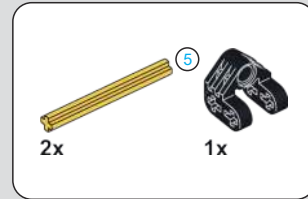
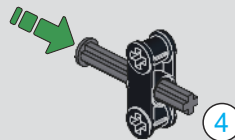

49

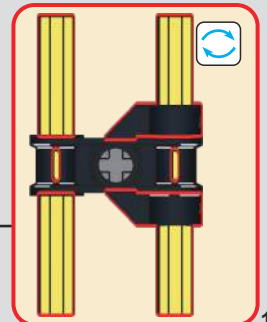
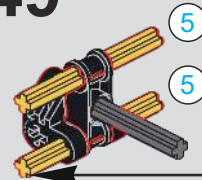

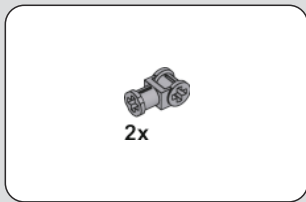

50

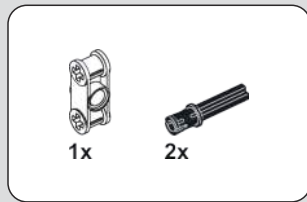
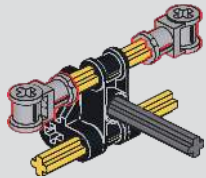

51

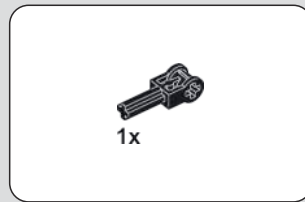
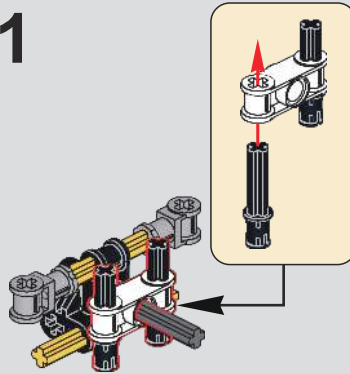

52

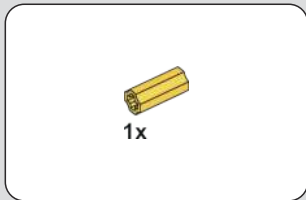
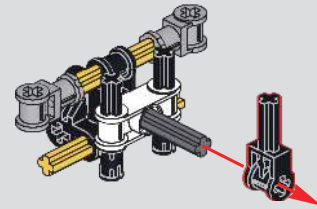

53

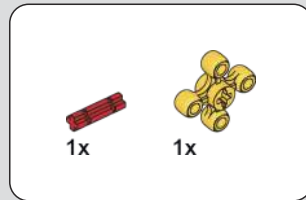
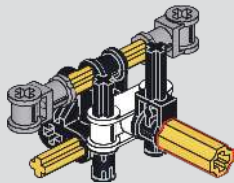

54

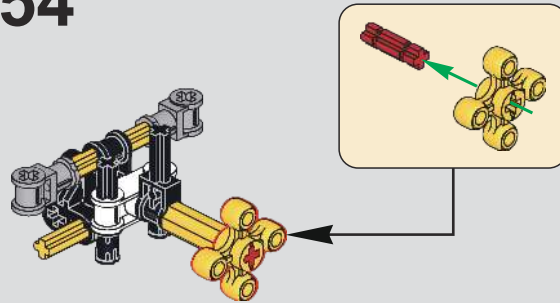

# 55

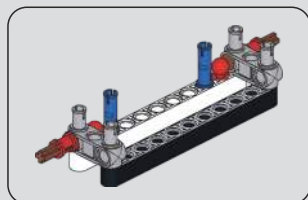
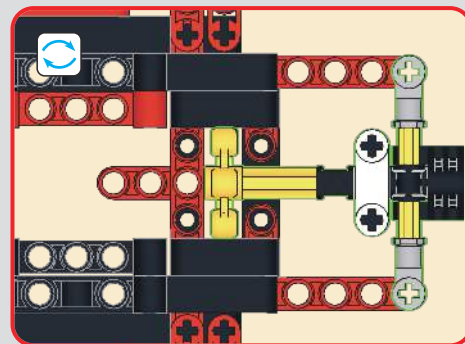
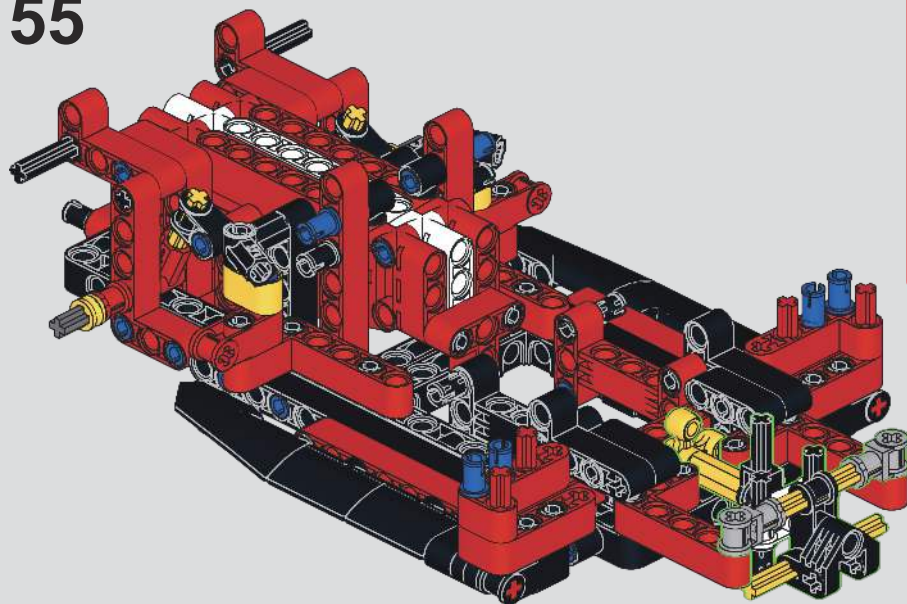

(Technic Pin without Friction)  
(光滑栓)



# 56

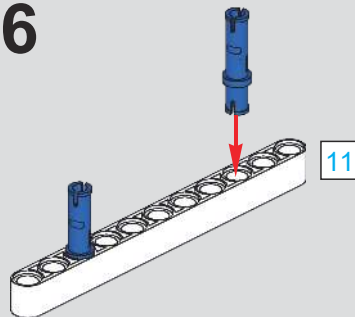

# 57

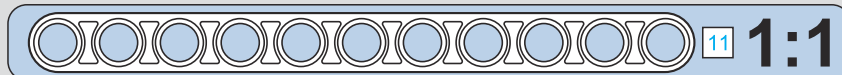
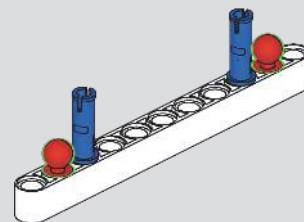

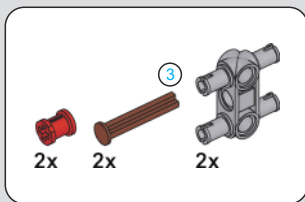

58

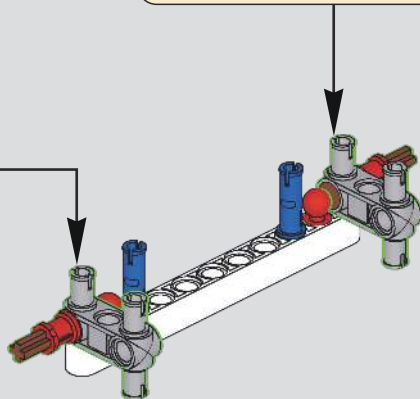
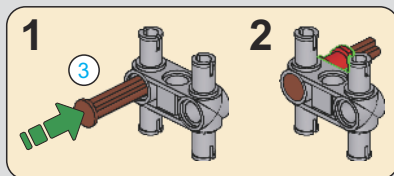
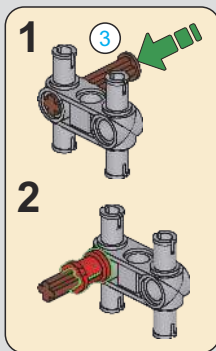

59

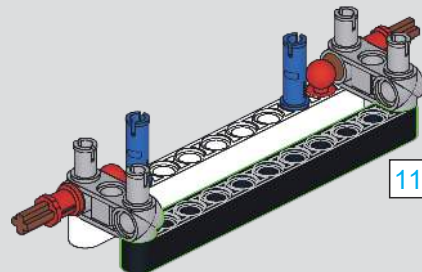

60

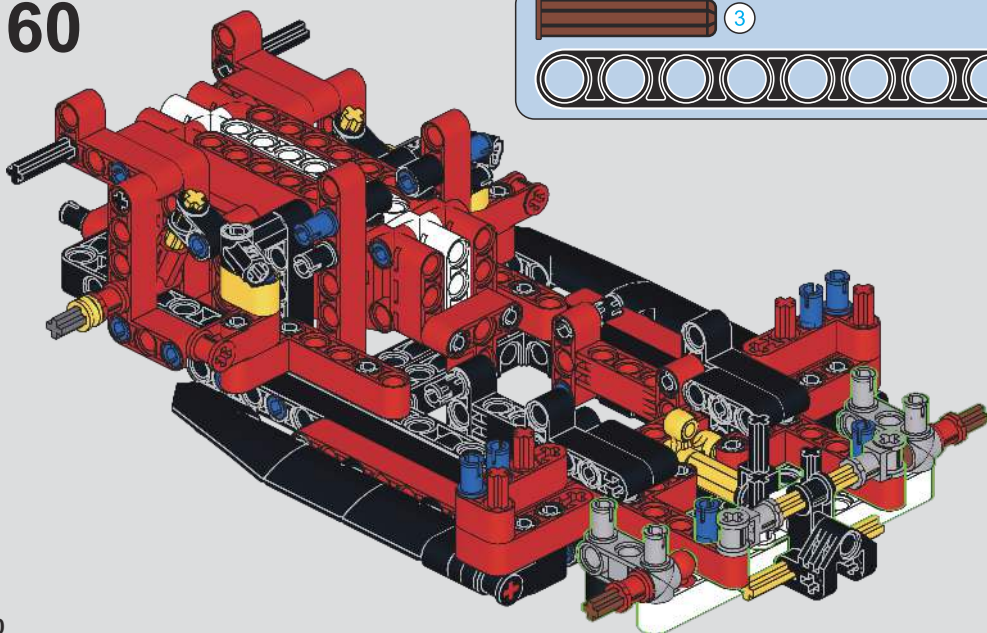

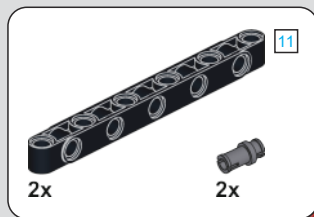

61

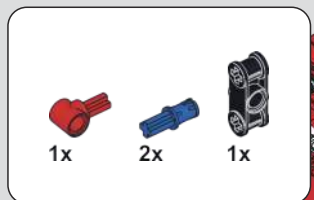
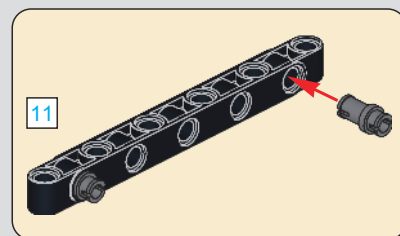
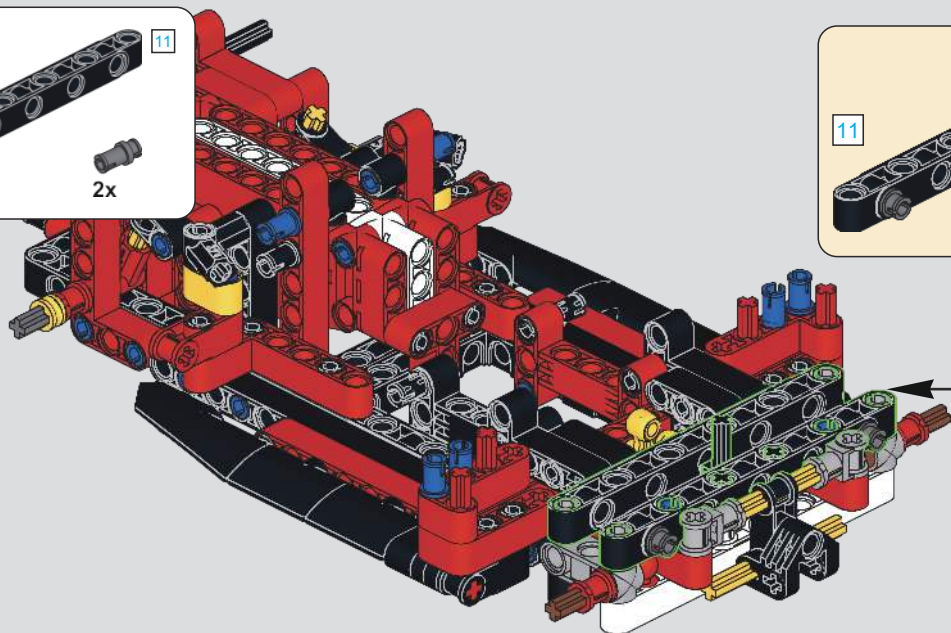

62

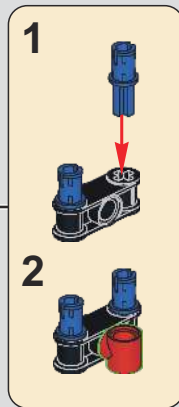
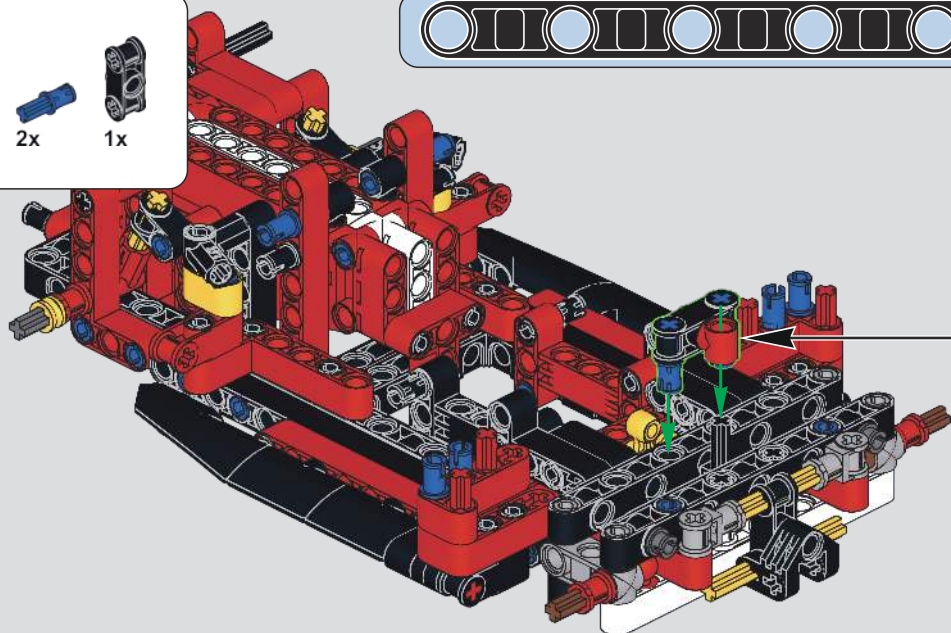

(Technic Pin without Friction)  
(光滑栓)

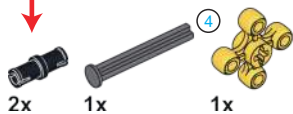

63

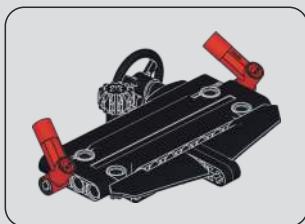
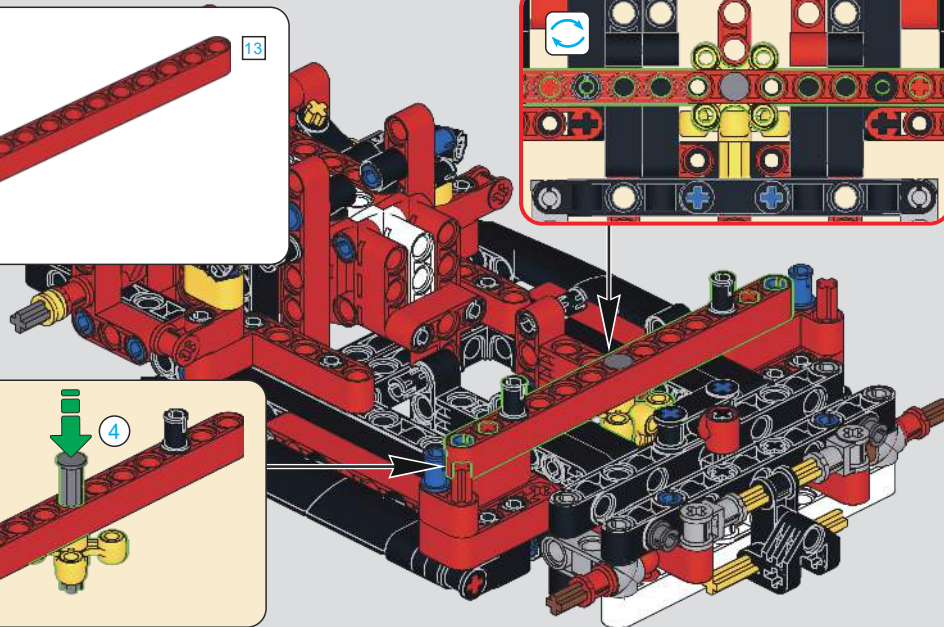
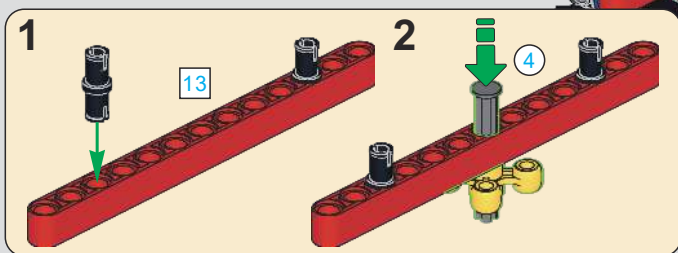
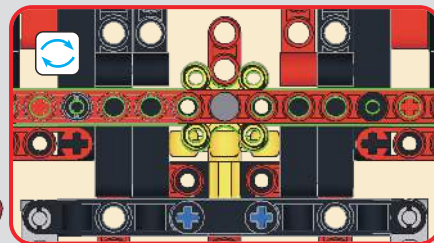

64

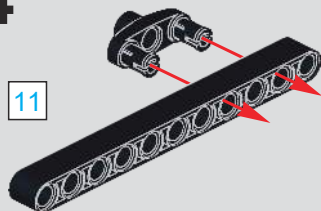

65

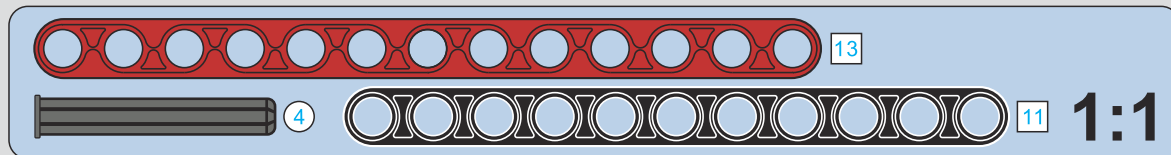

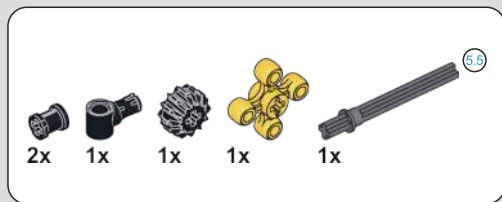

66

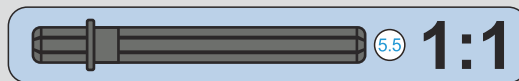
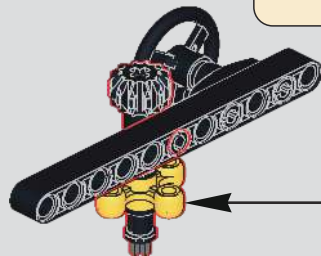
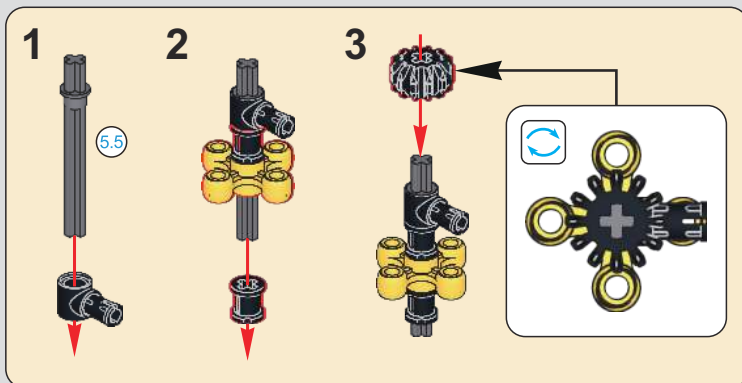

67

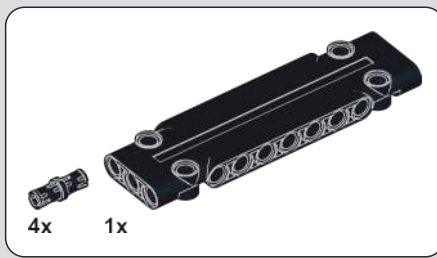
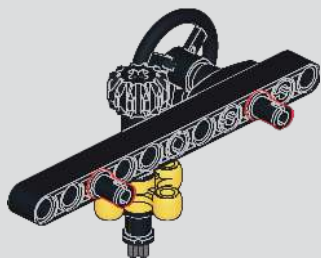

68

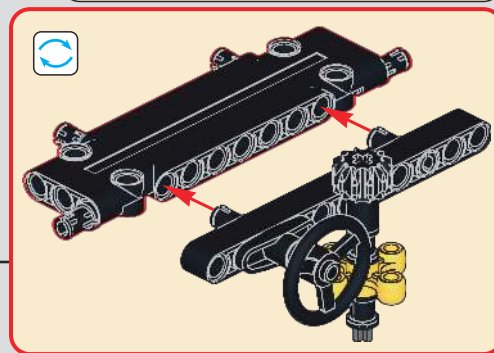
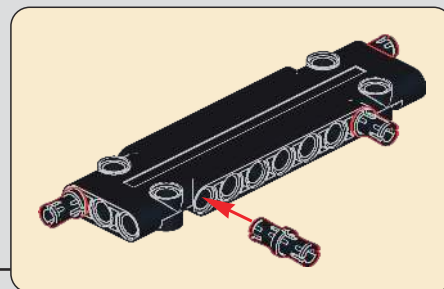
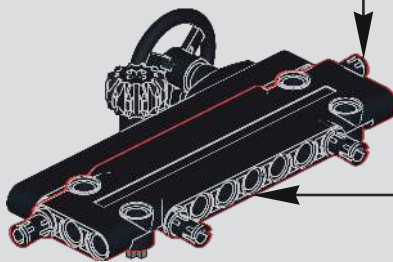

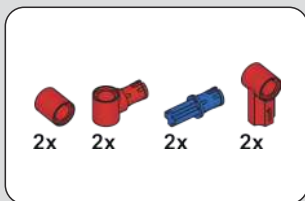

69

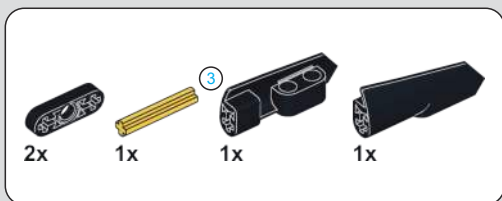
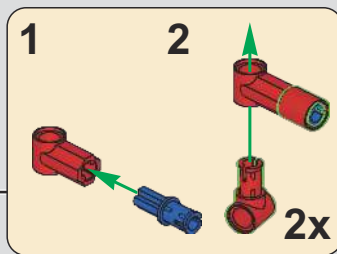
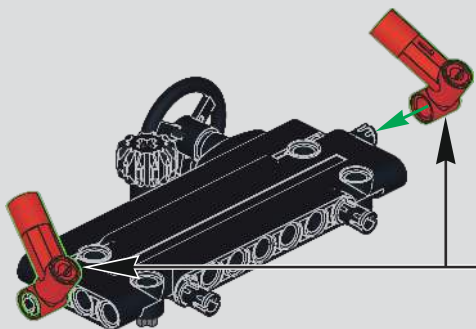

70

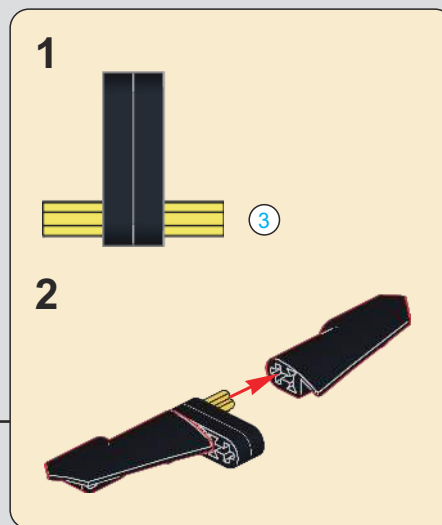
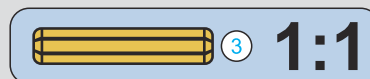
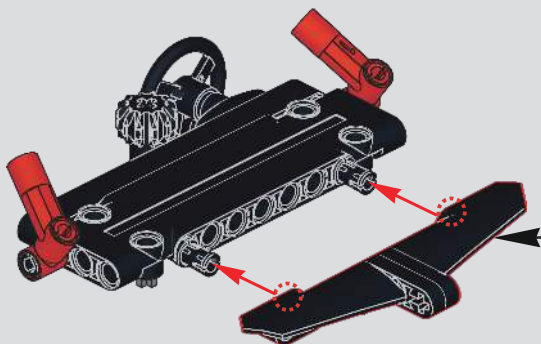

71

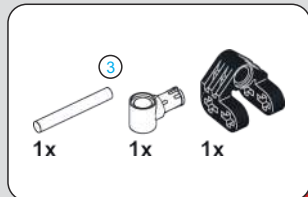
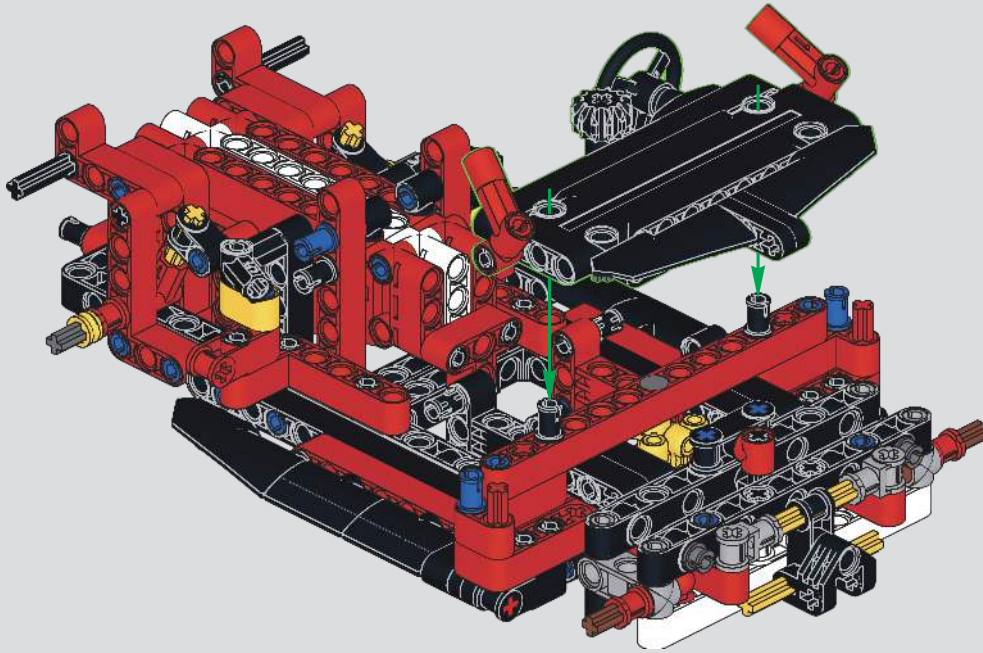

72

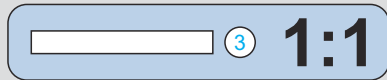
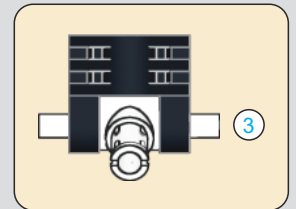
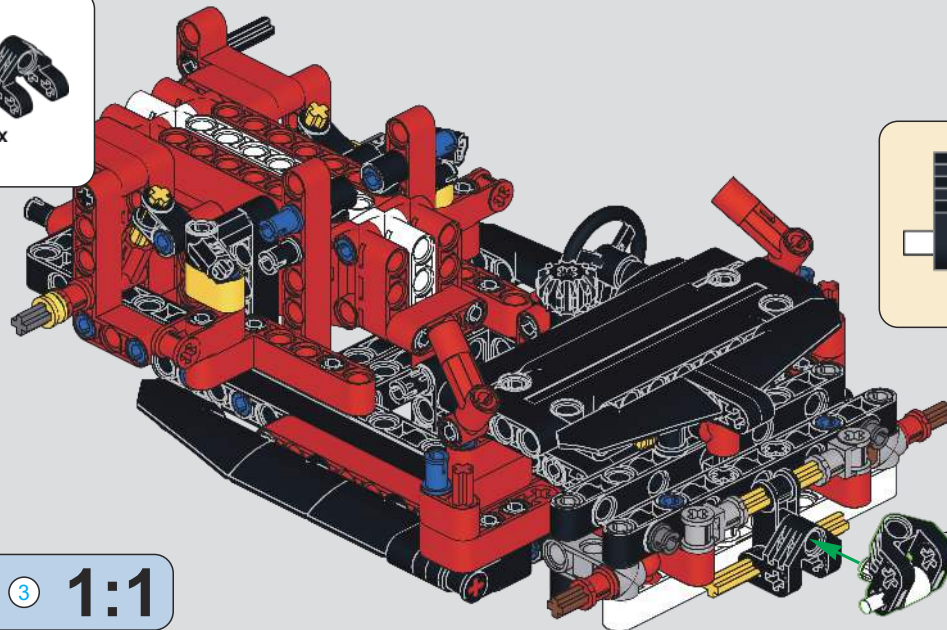

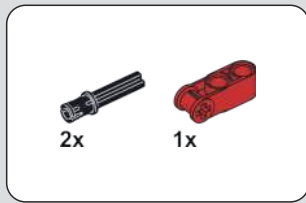
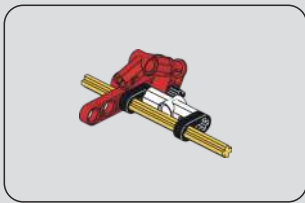

73

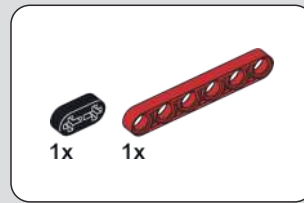

74

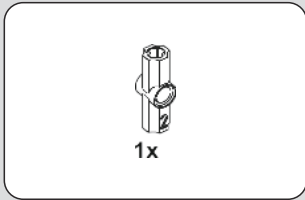
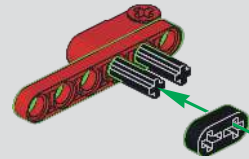
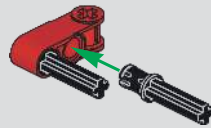

75

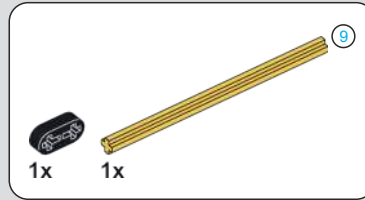

76

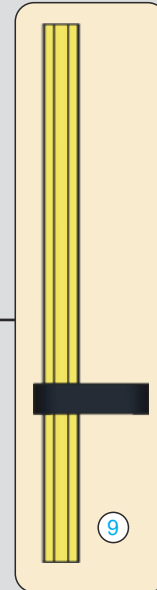
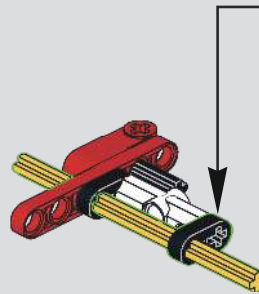
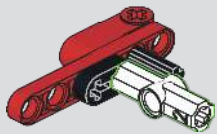

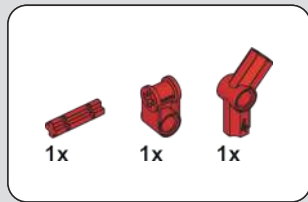



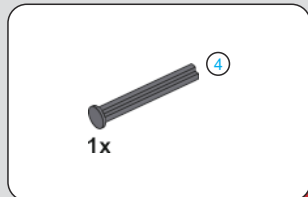
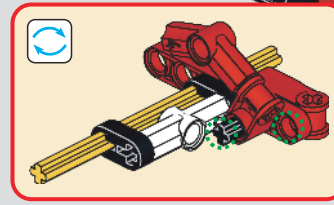
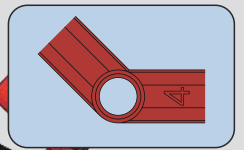
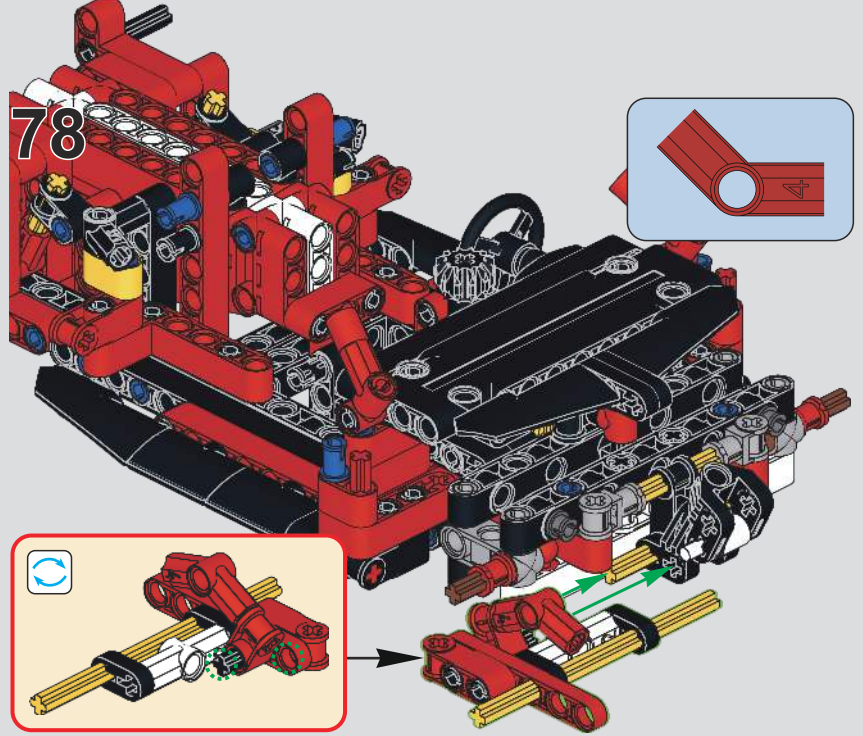
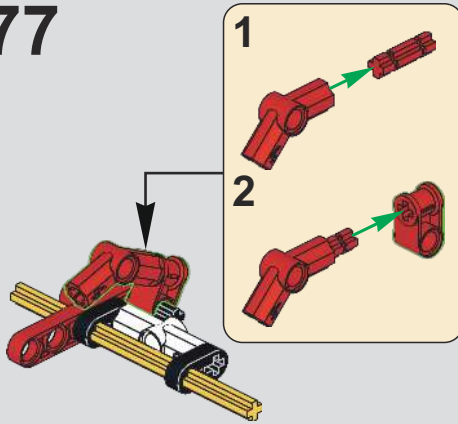

77

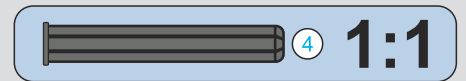
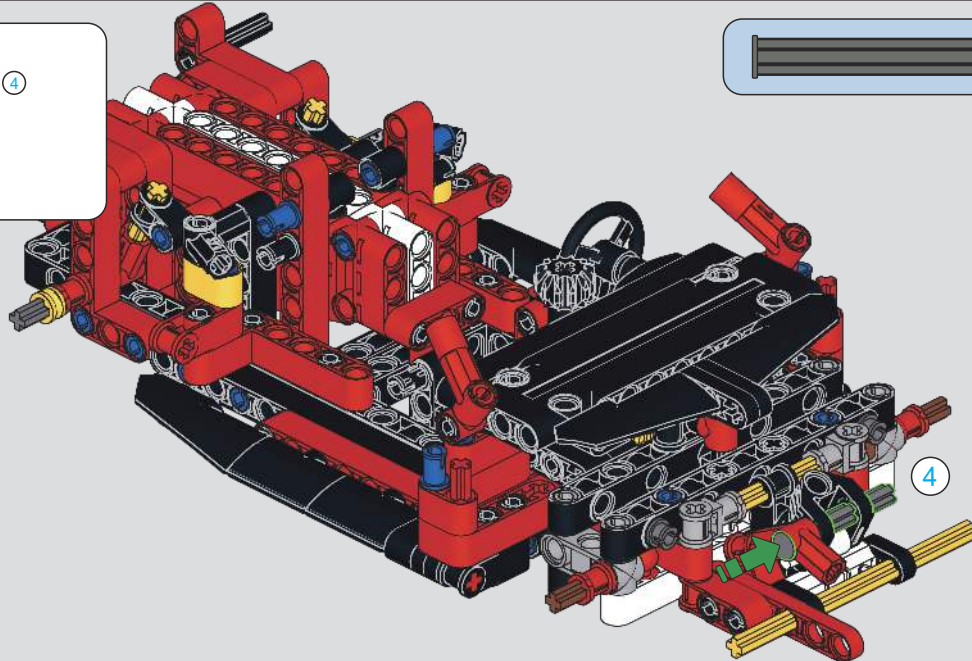

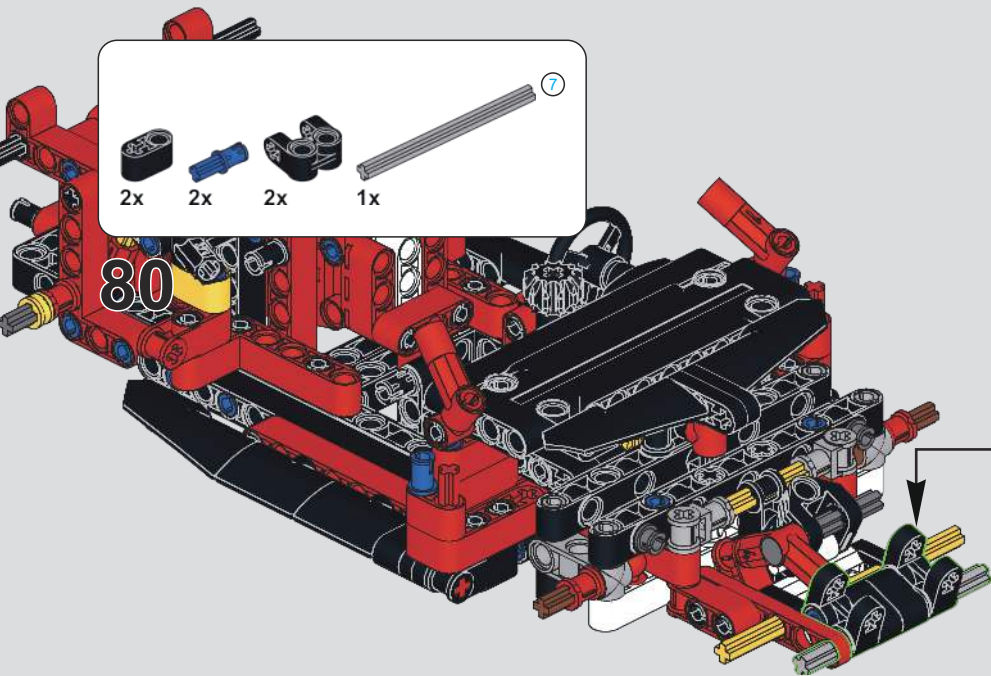
79



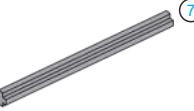

-  2x
-  2x
-  2x
-  1x 7

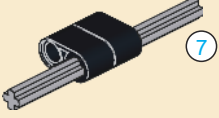

80

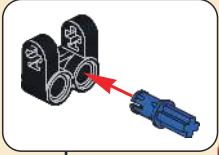
1  7

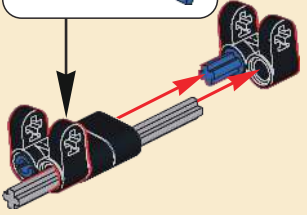
2 

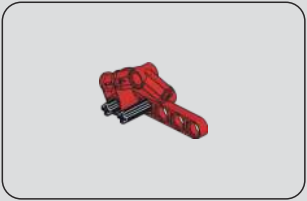



-  2x
-  1x

81

-  1x

82

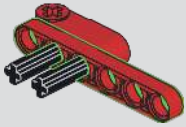
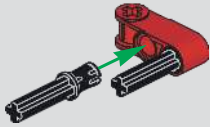

-  7 1:1

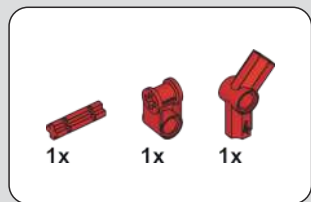

83

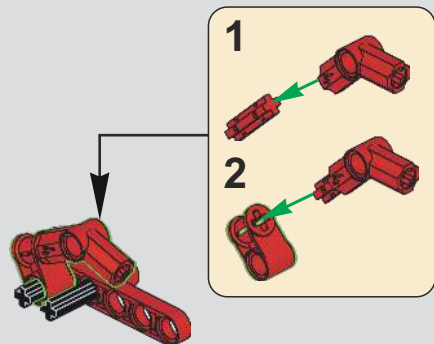

84

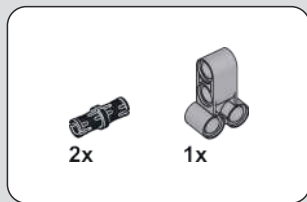
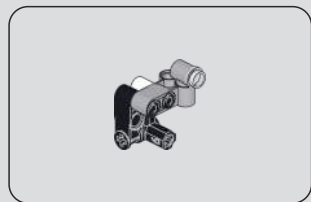
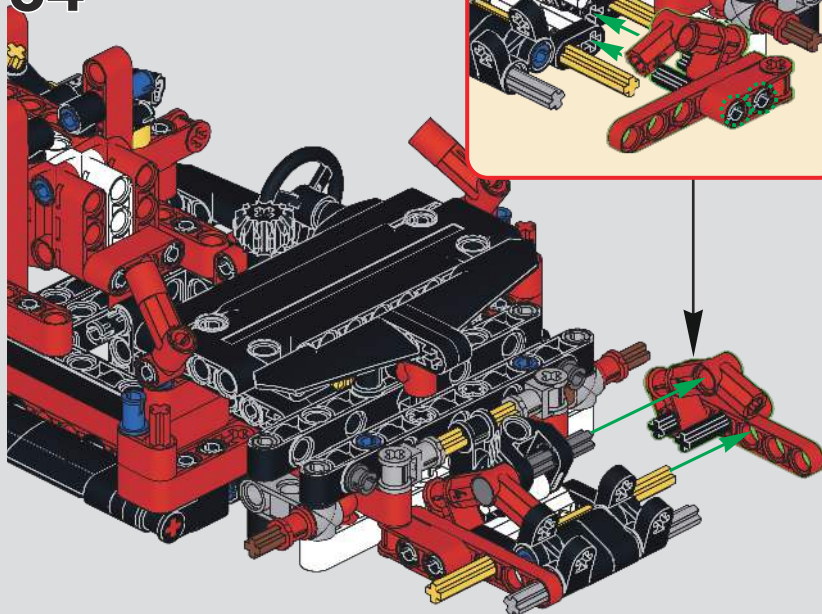

85

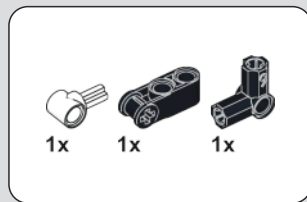
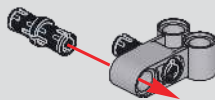
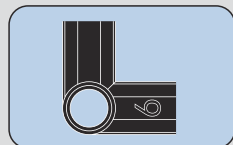
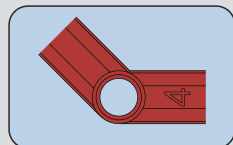

86

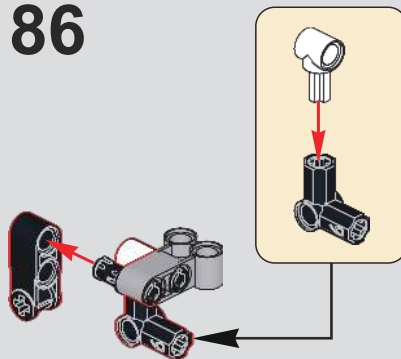



87

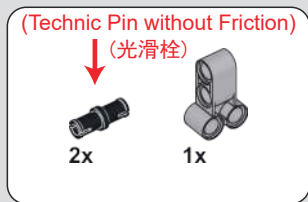
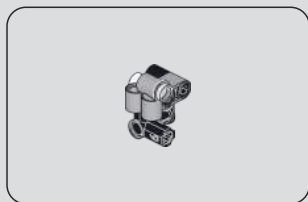
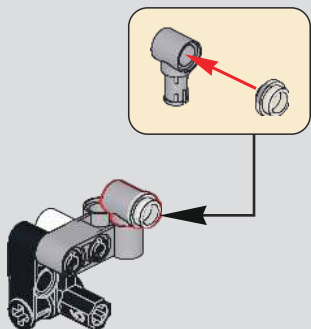

88

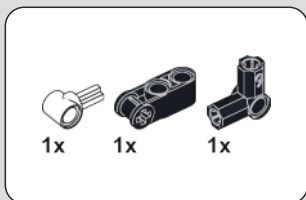
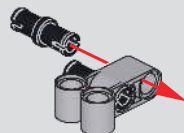

89

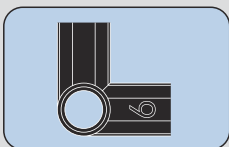
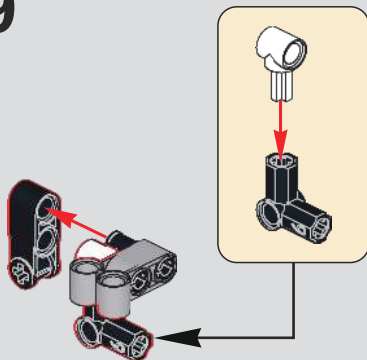

90

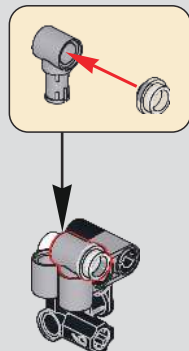

91

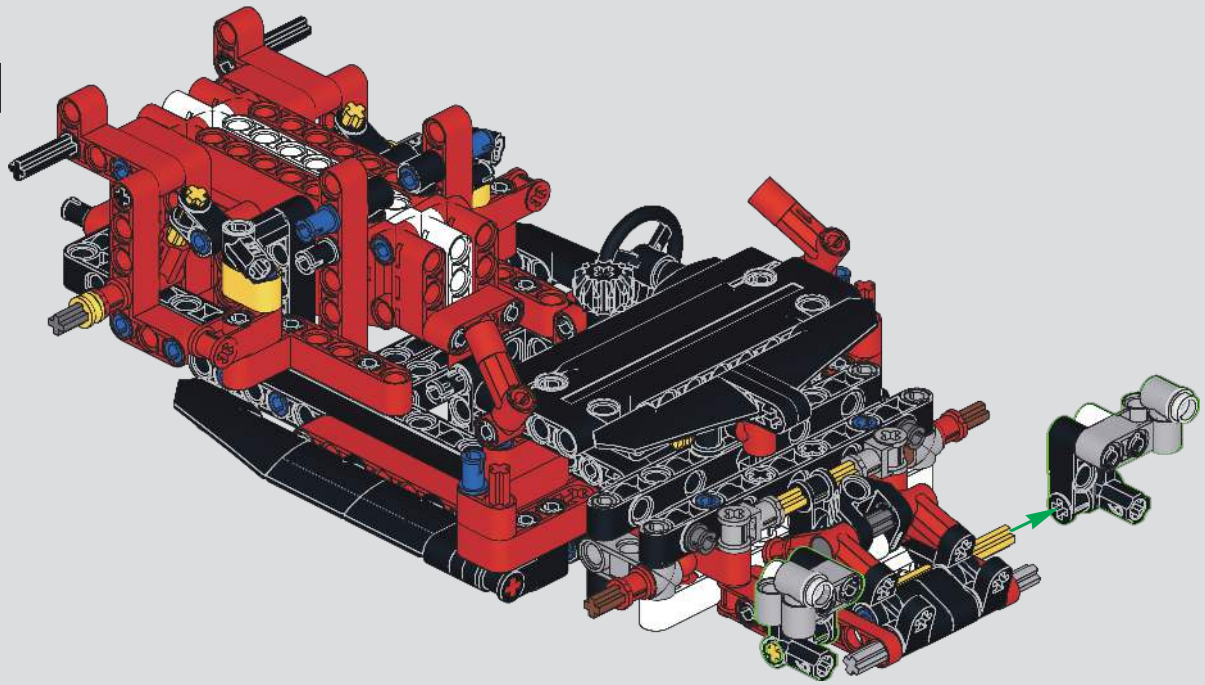

92

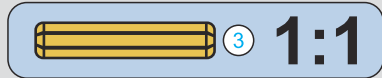
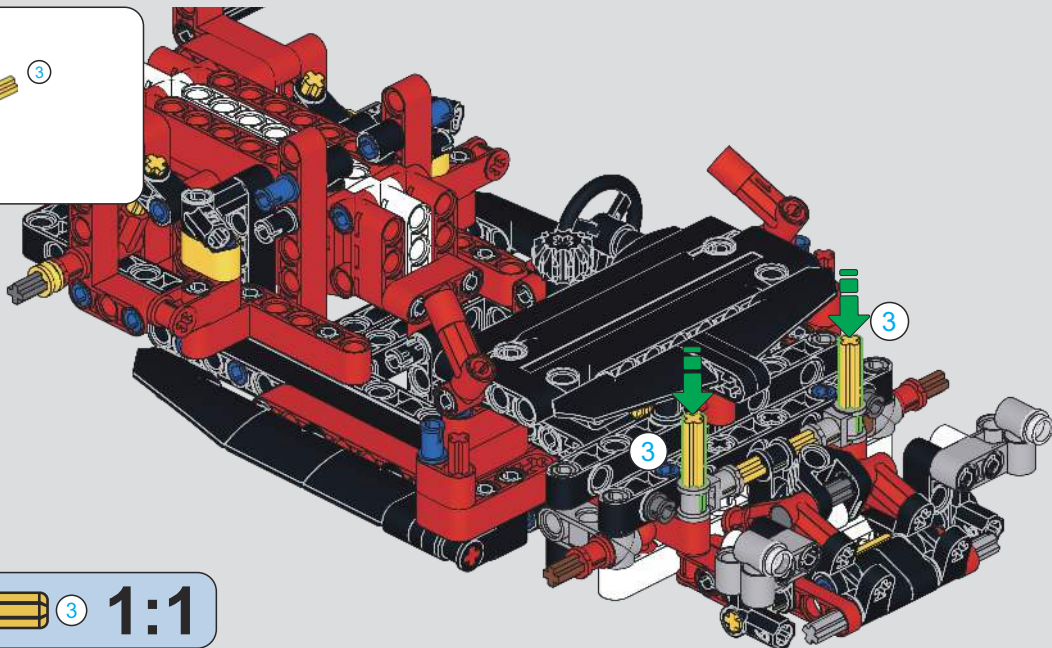
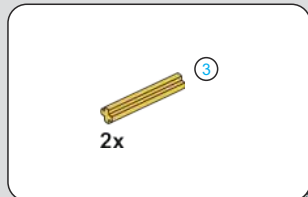

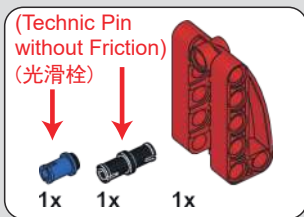
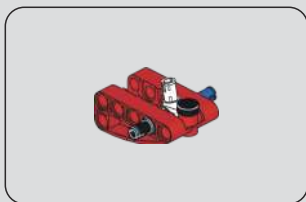

93



94

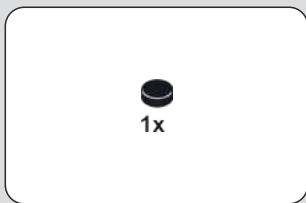
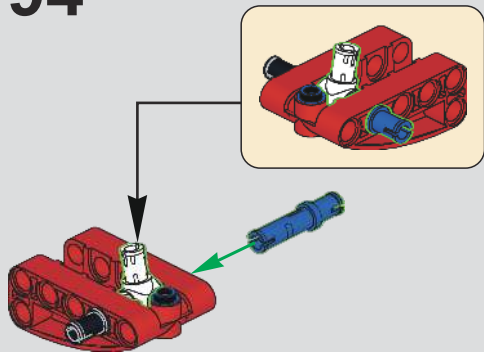
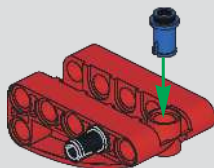

95

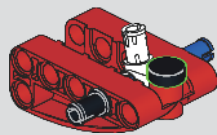

96

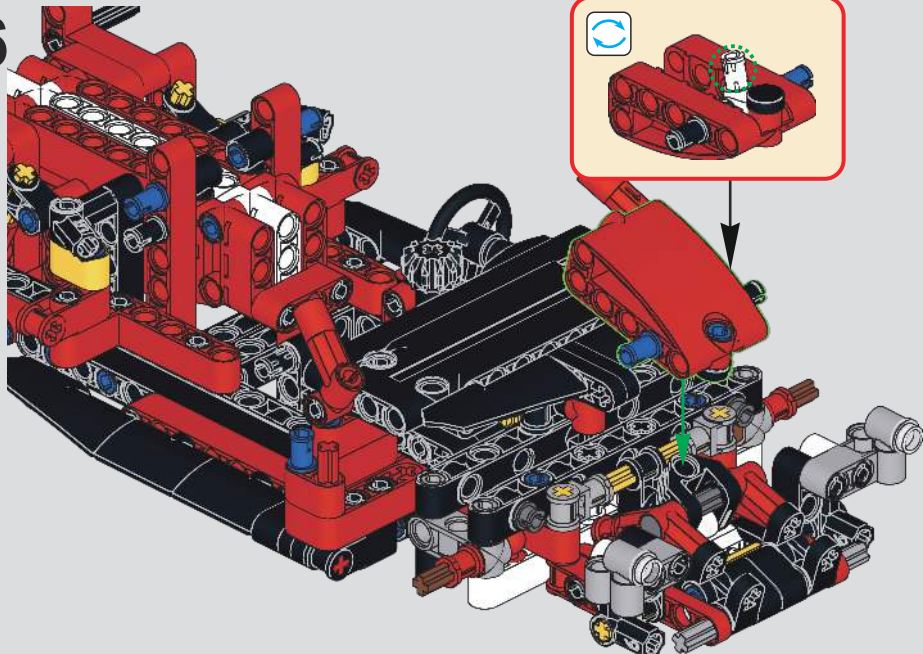

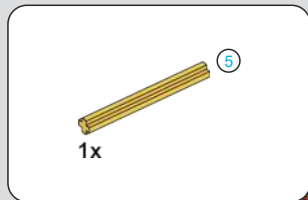

97

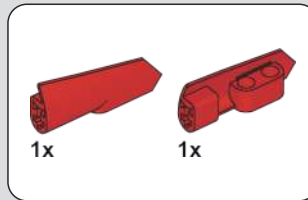
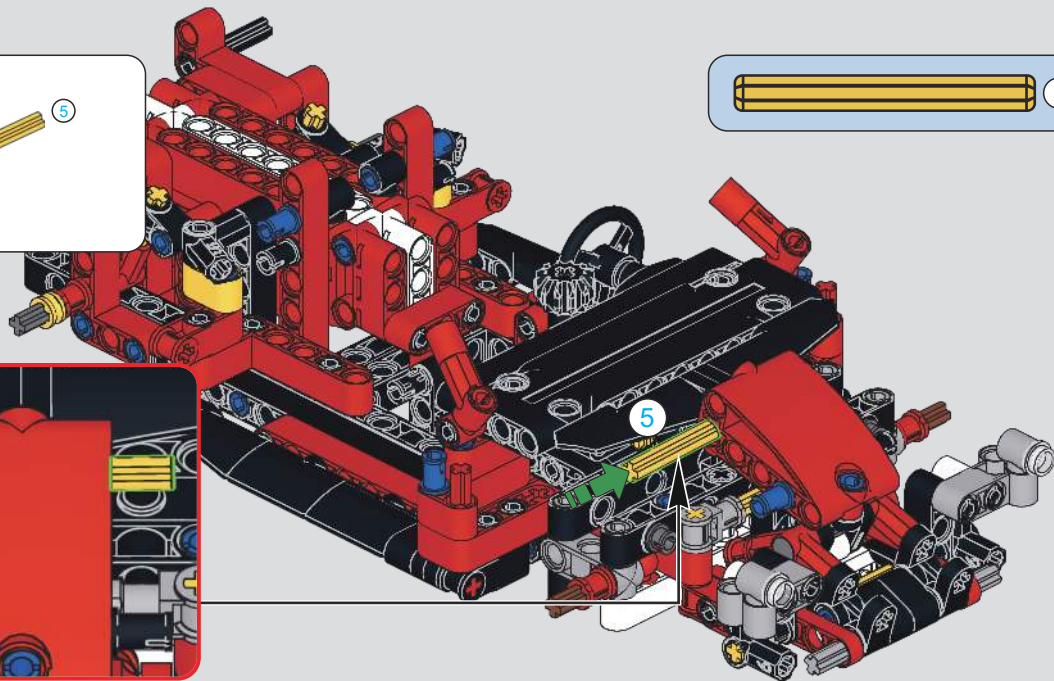
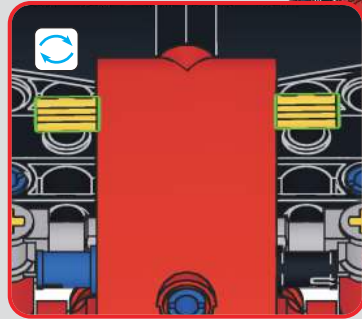

98

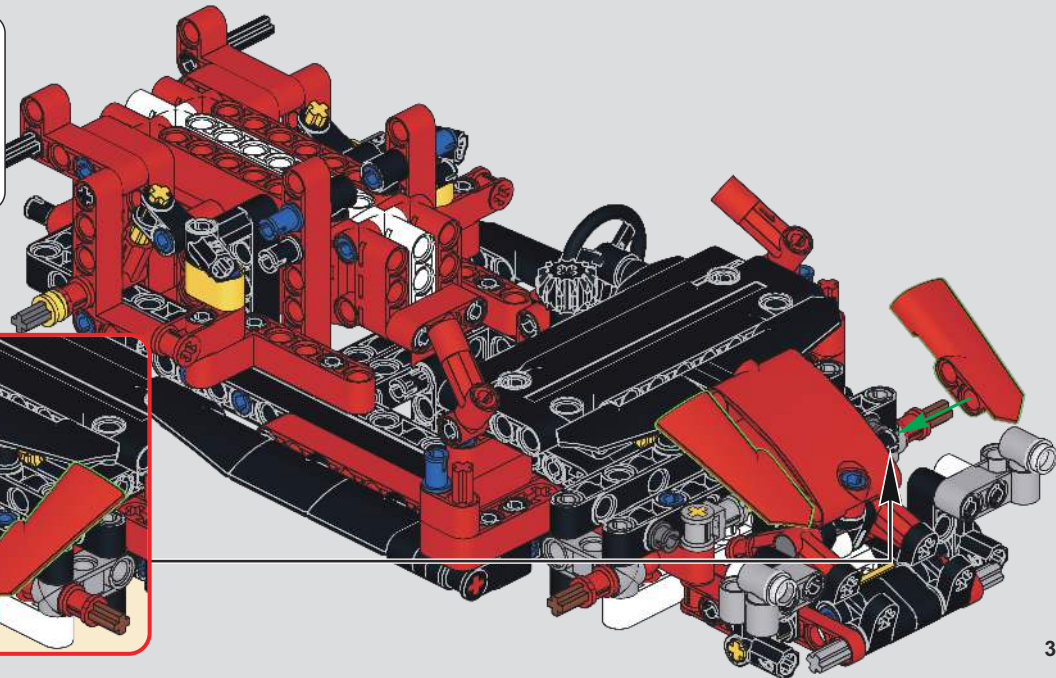
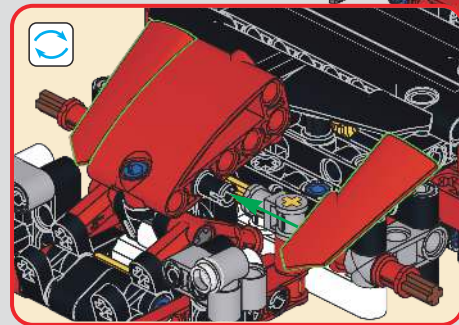

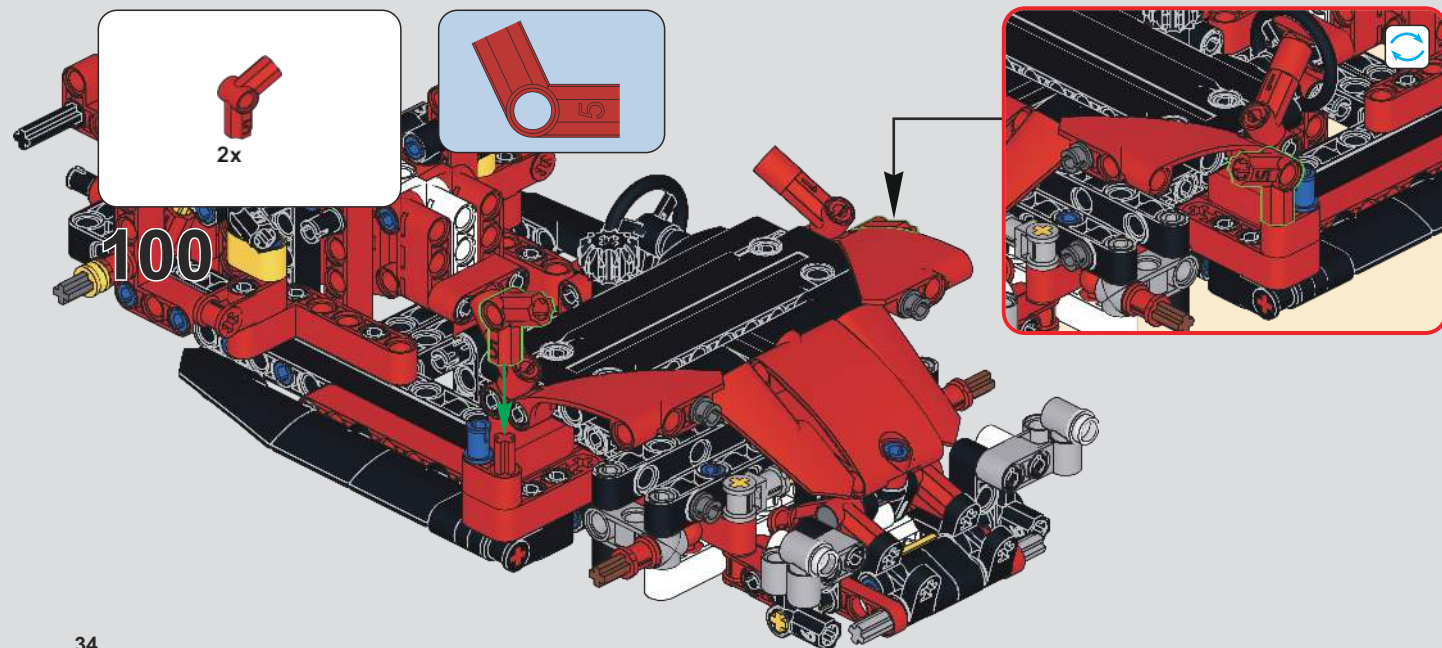
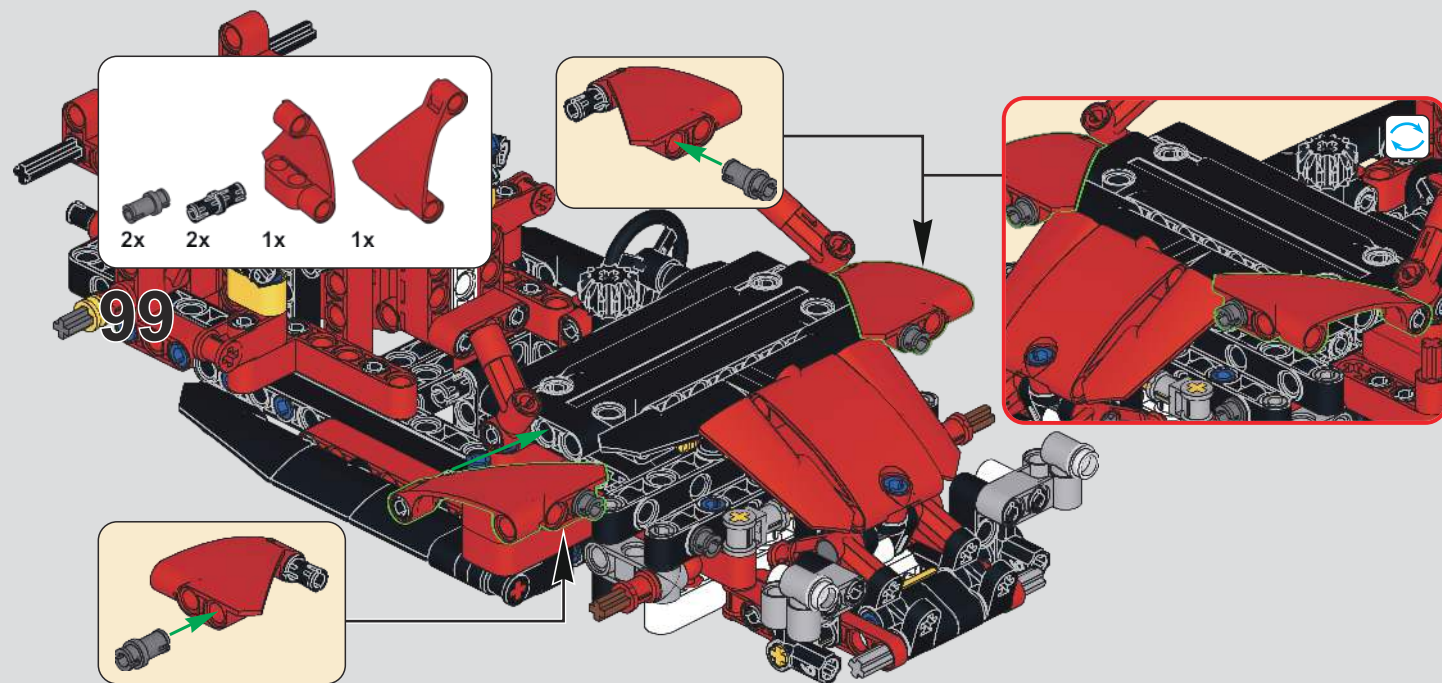



101

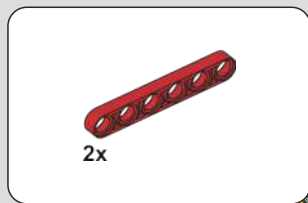
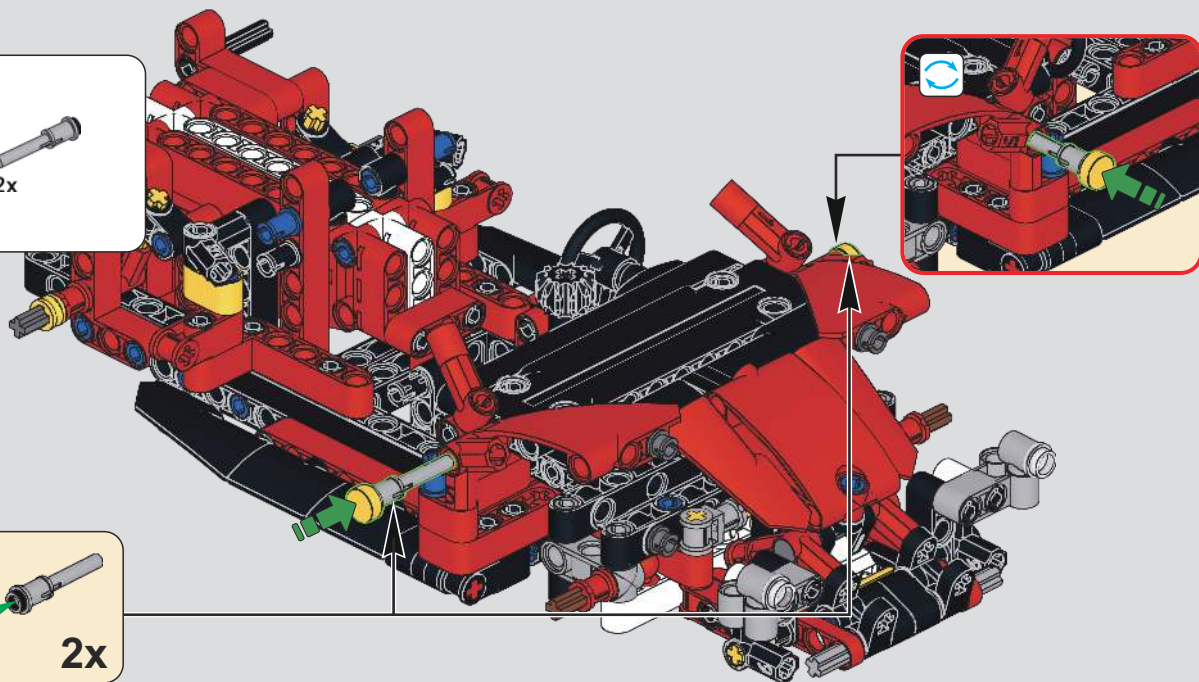
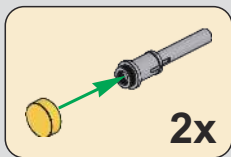

102

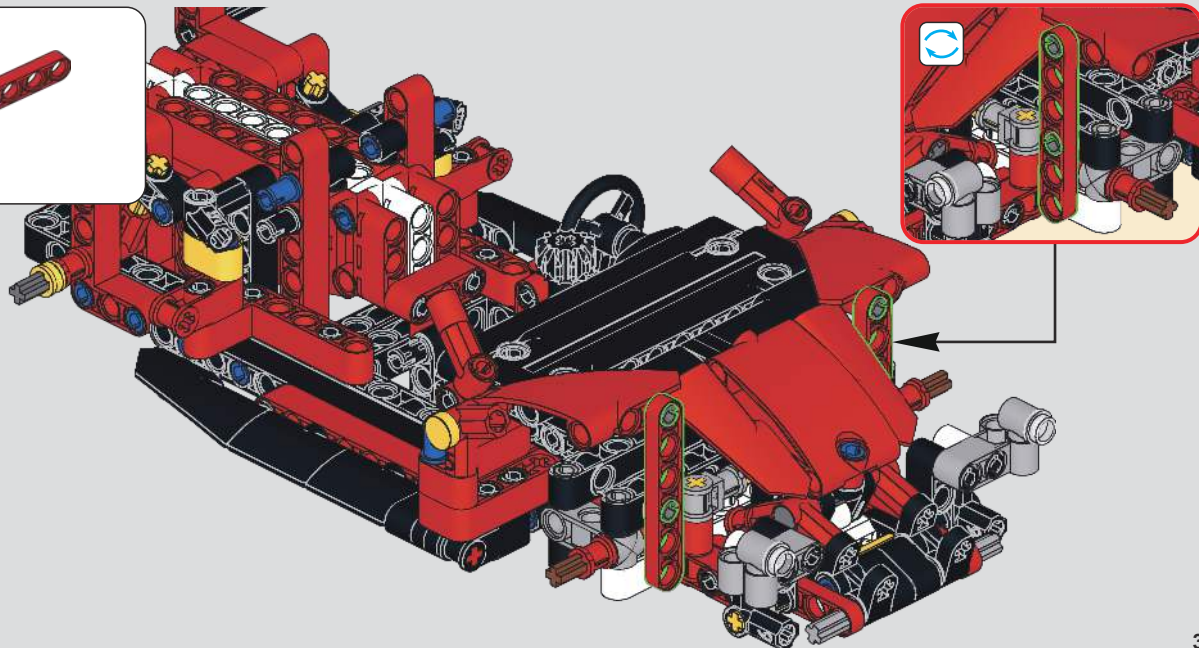

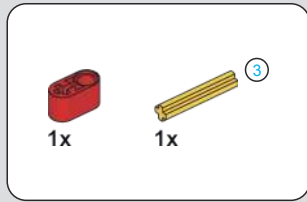
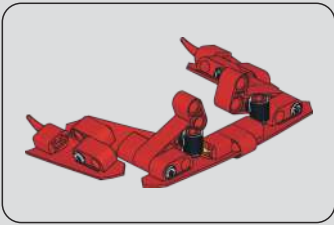

103

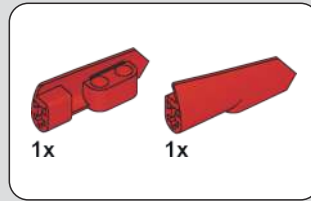

104

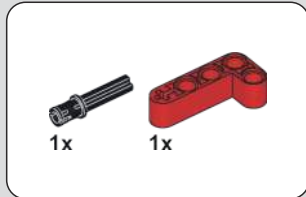
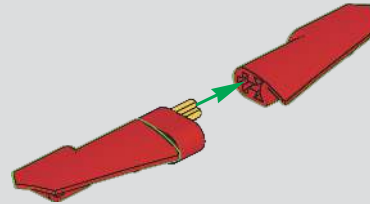
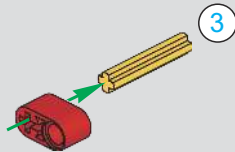
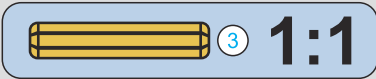

105



106

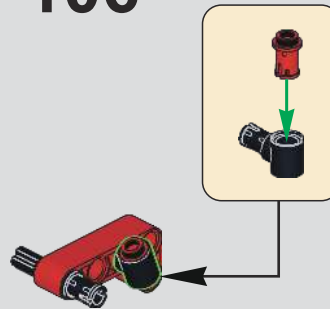
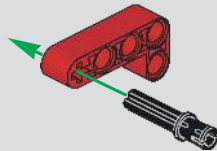

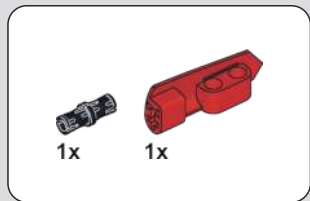

107

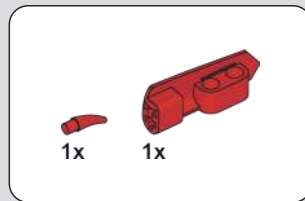
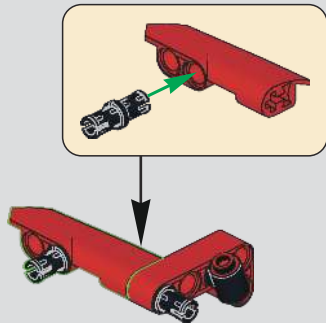

108

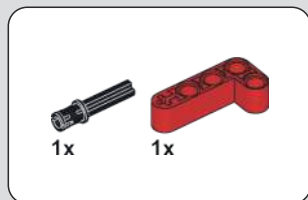
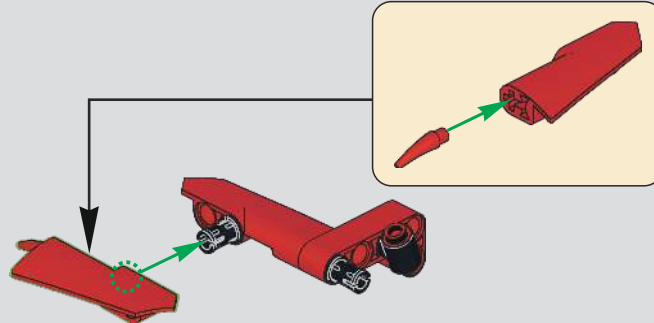

109

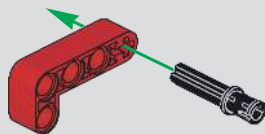

110

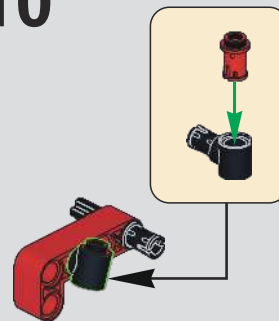

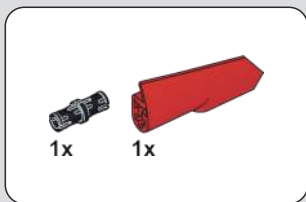

111

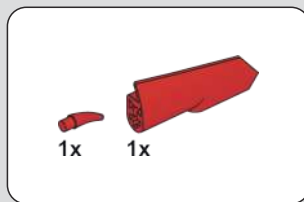
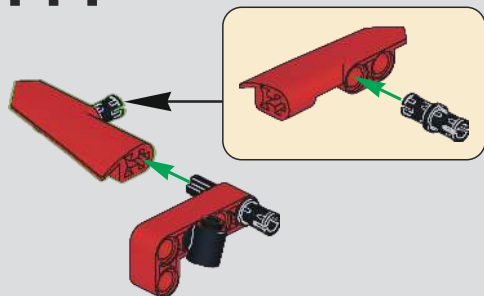

112

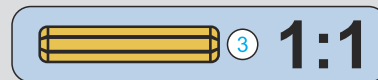
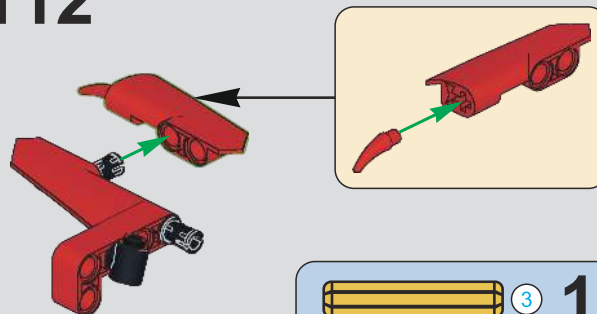

113

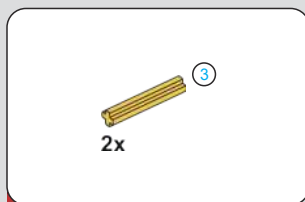
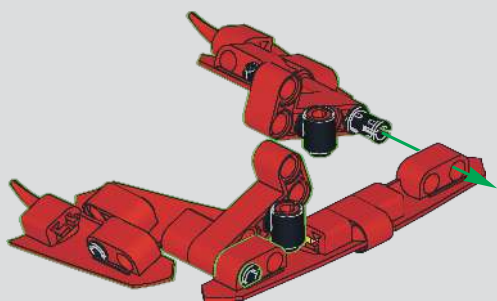

114

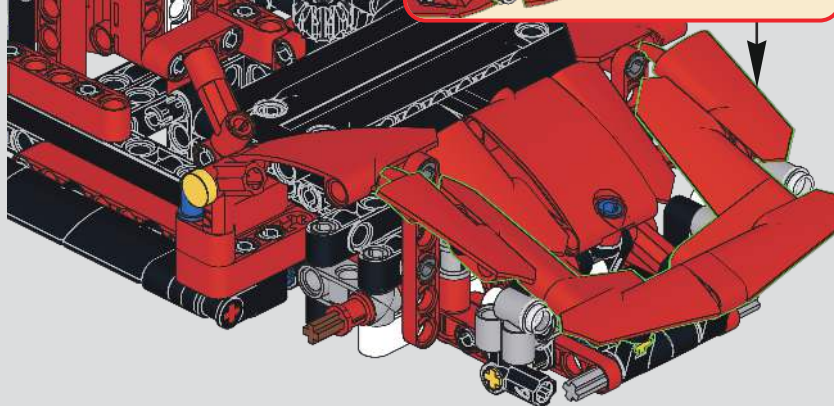

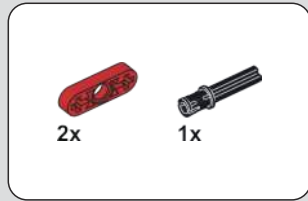
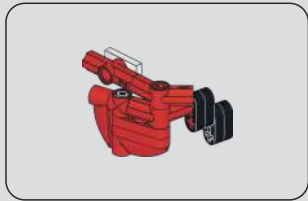

115

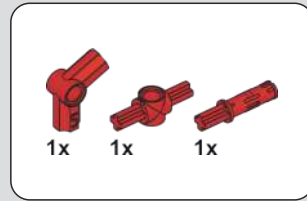
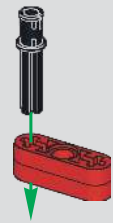
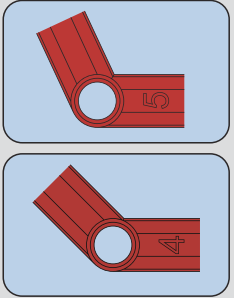

116

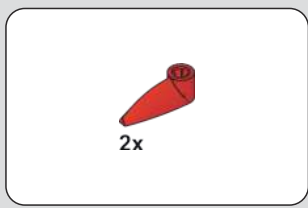
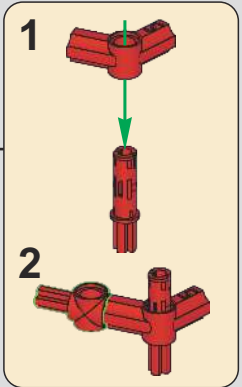
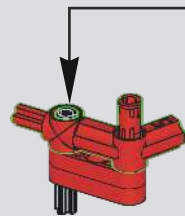

117

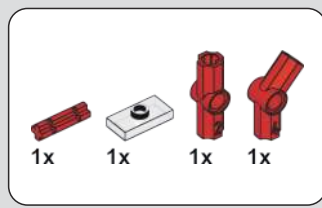
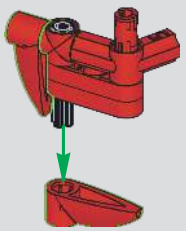

118

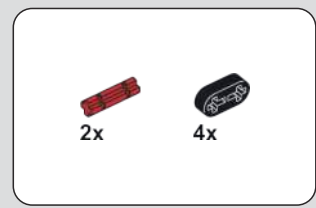
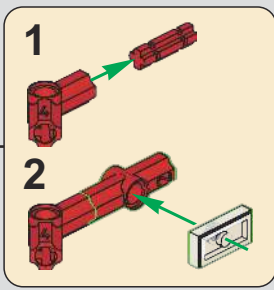
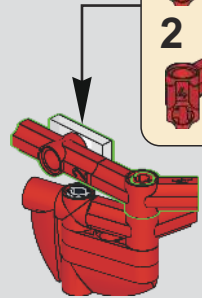

119

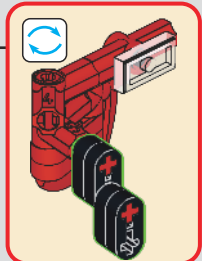
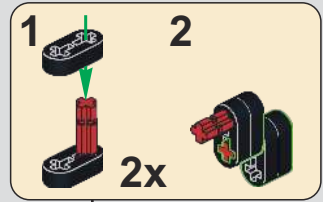
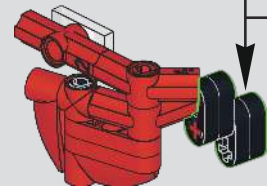

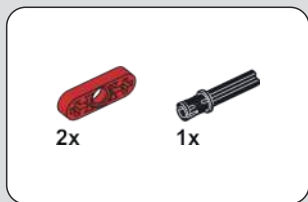

120

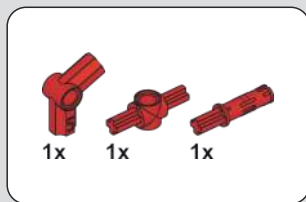

121

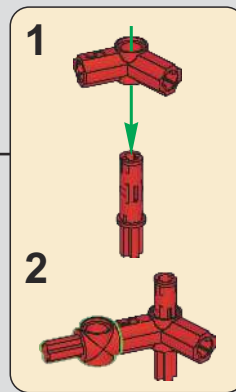
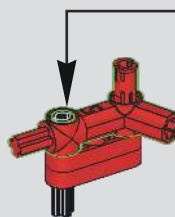
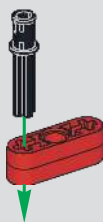
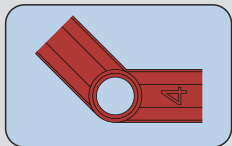
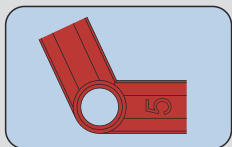

122

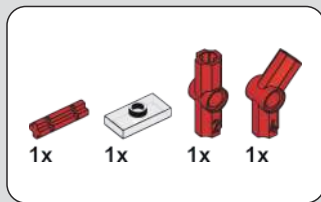

123



124

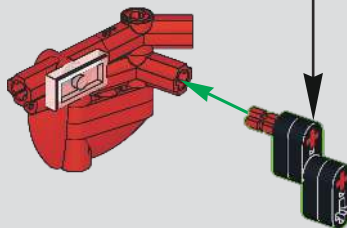
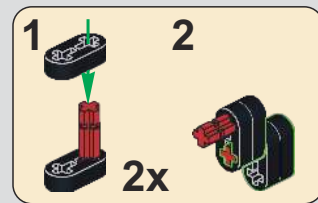
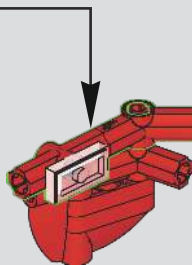
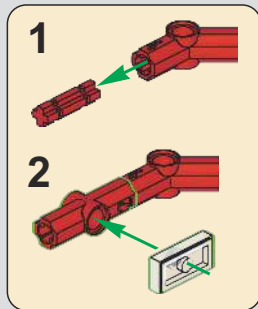
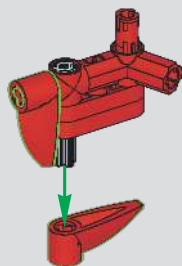

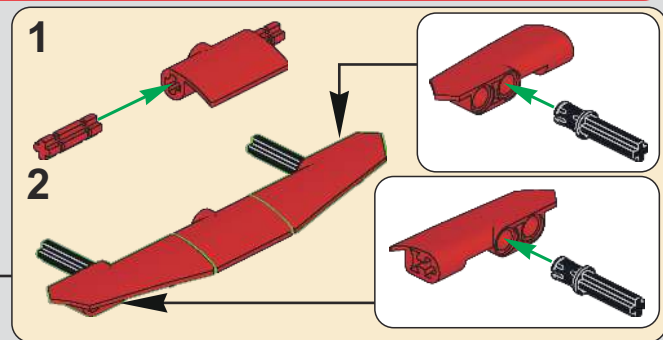
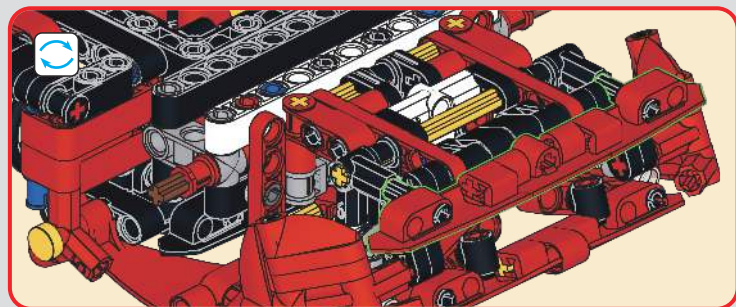
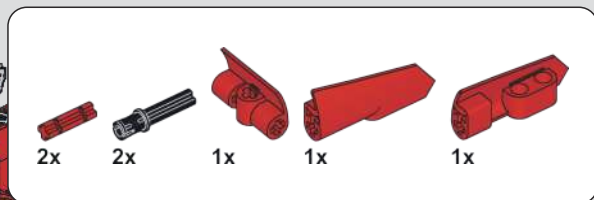
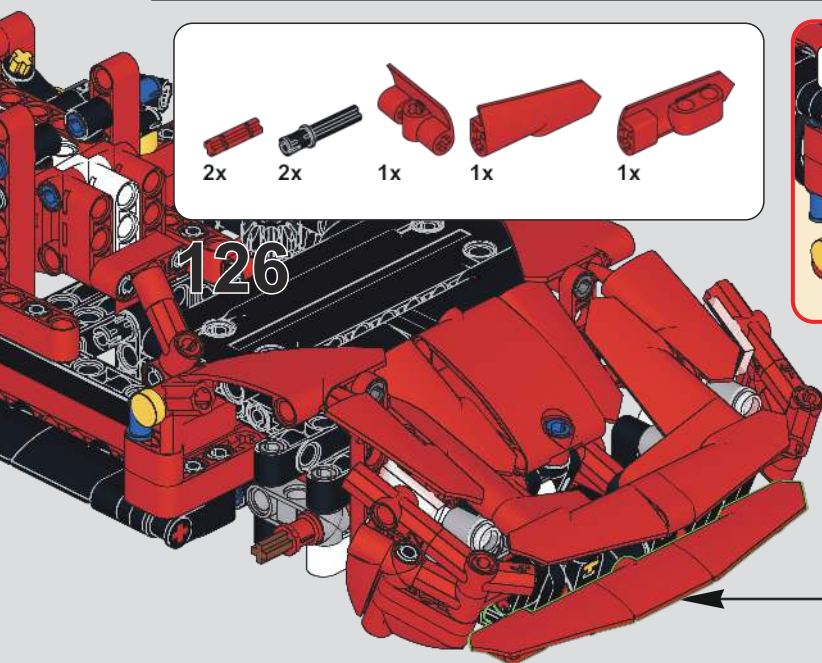
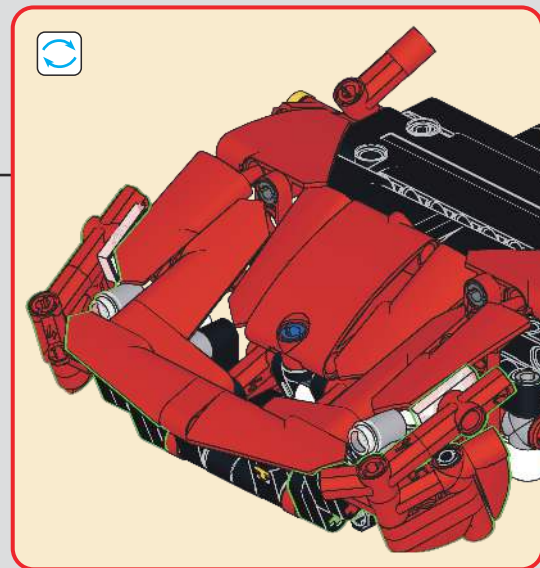
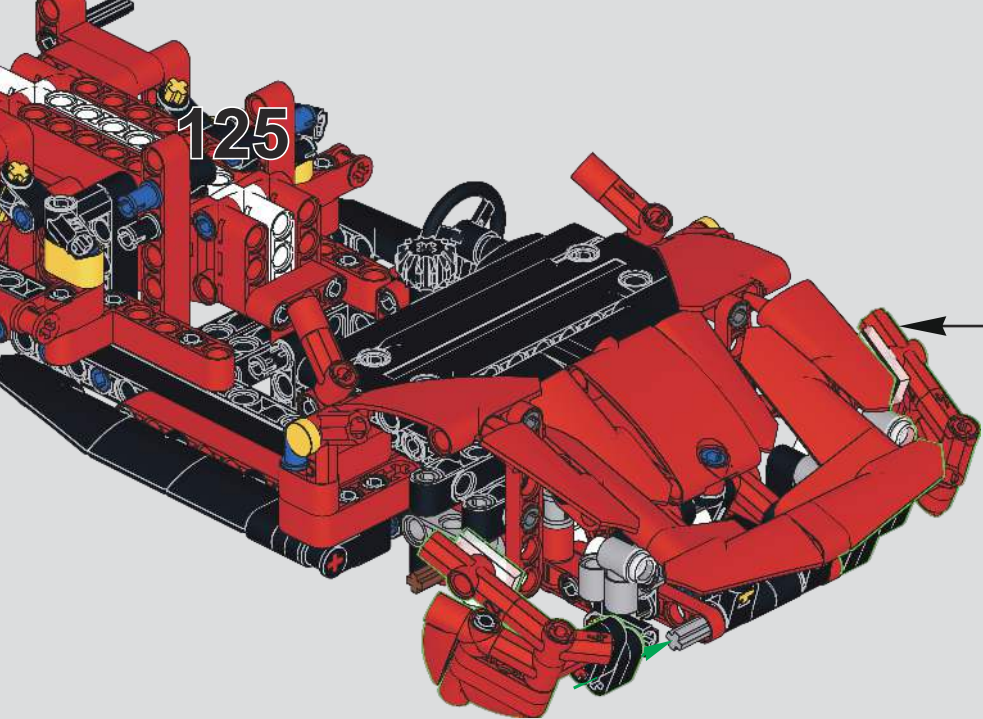

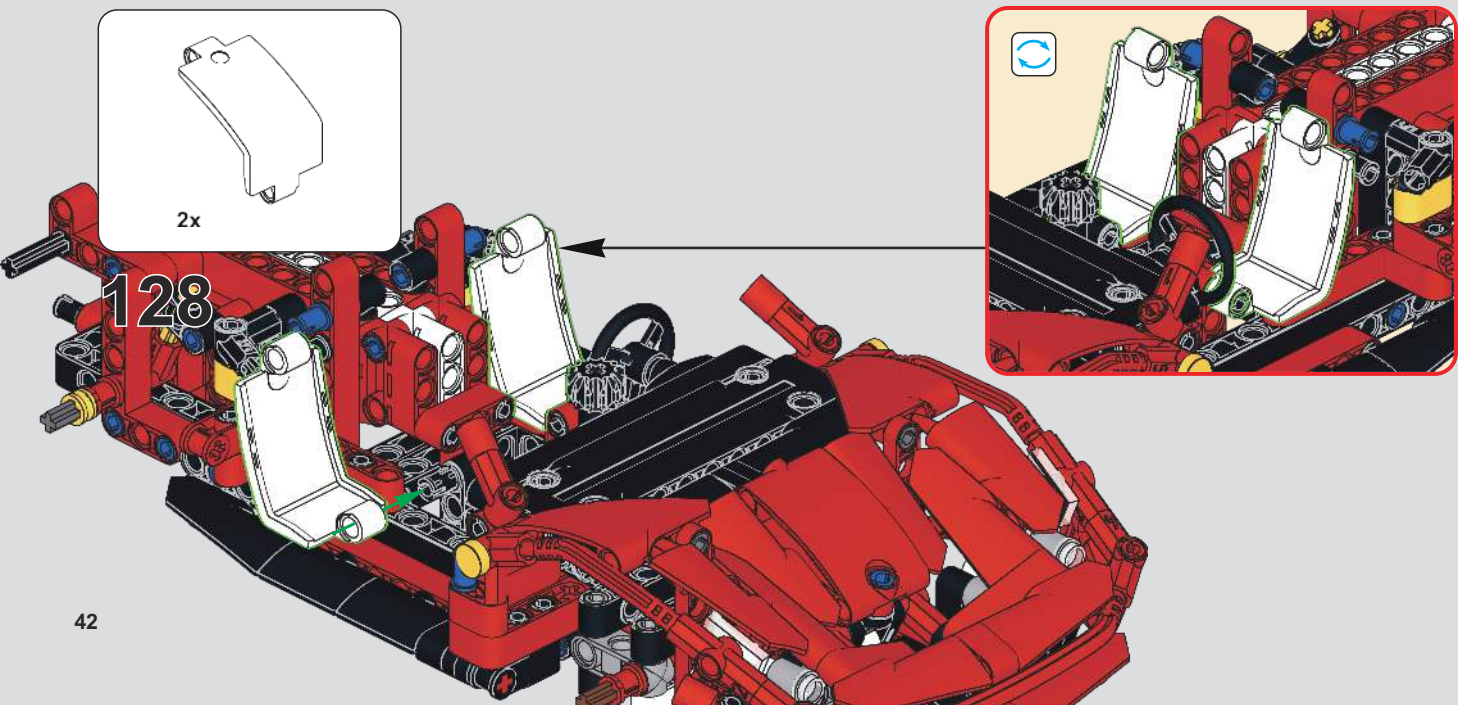
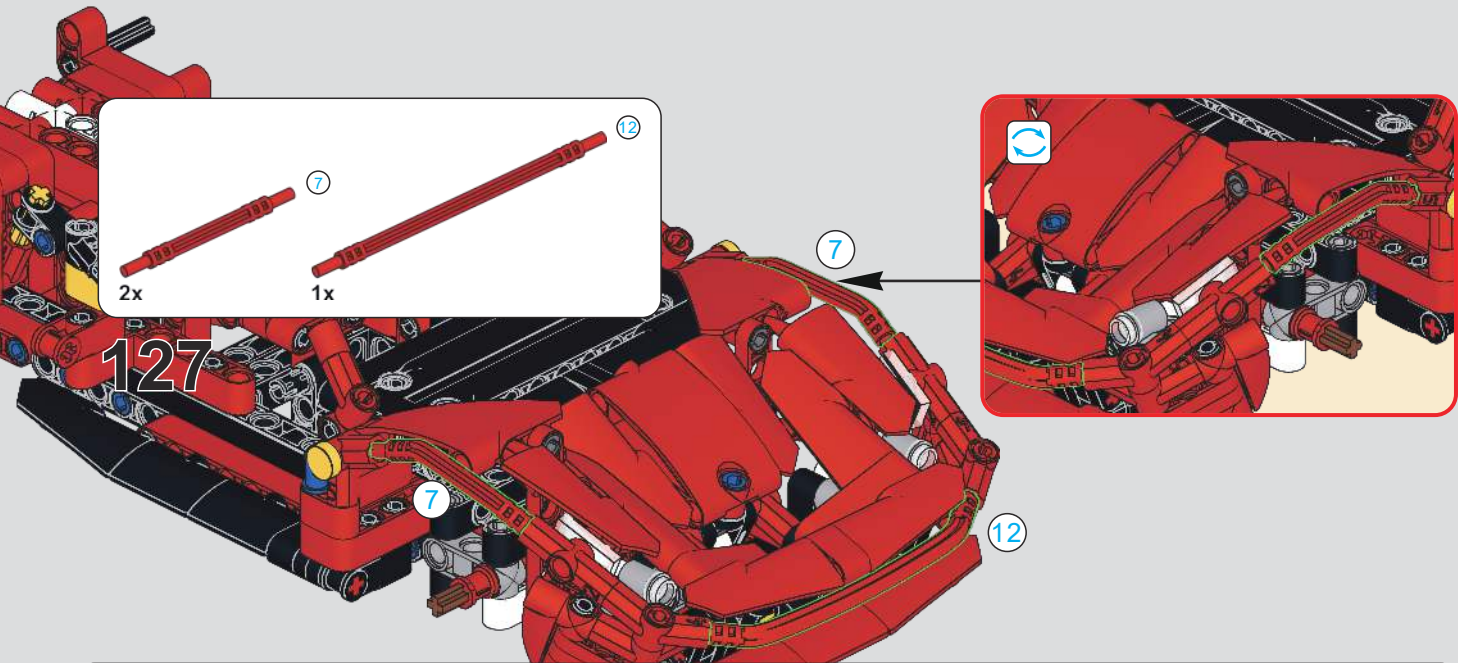





134

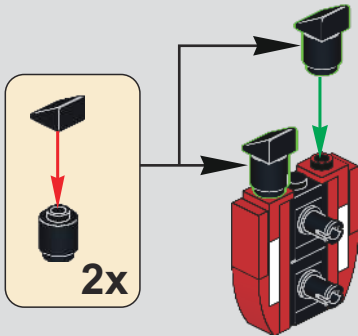

135

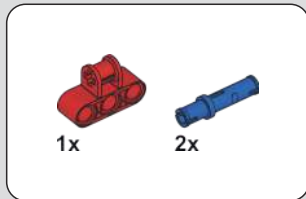
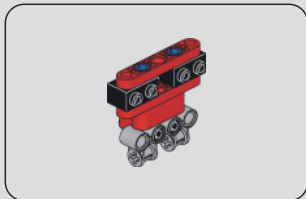
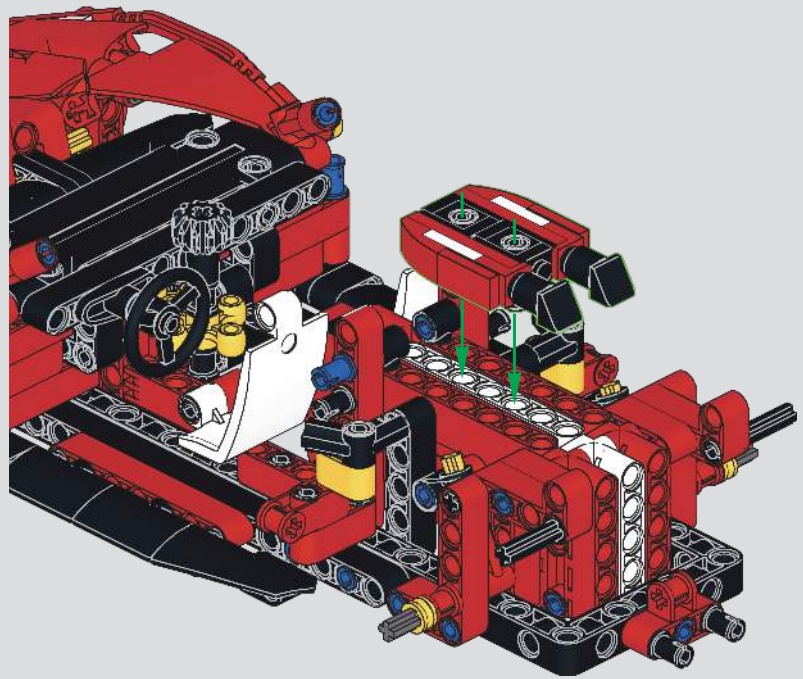

136

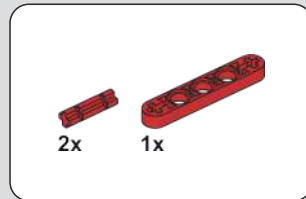

137

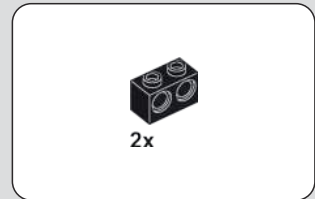

138

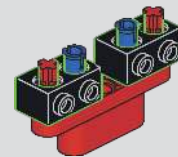
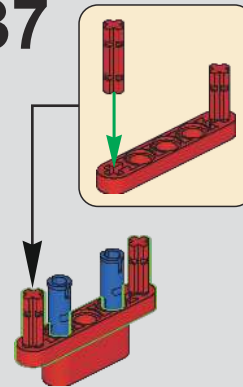
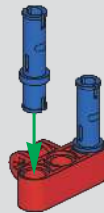



139

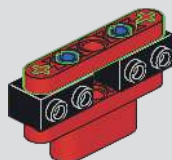

140

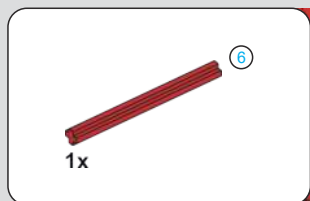
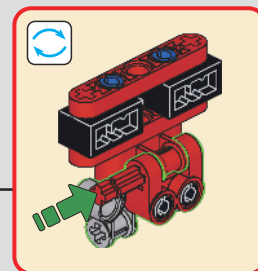
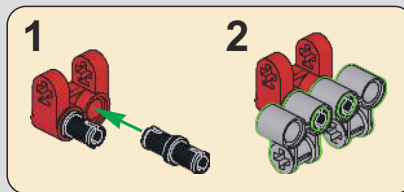
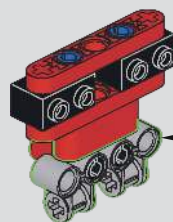

141

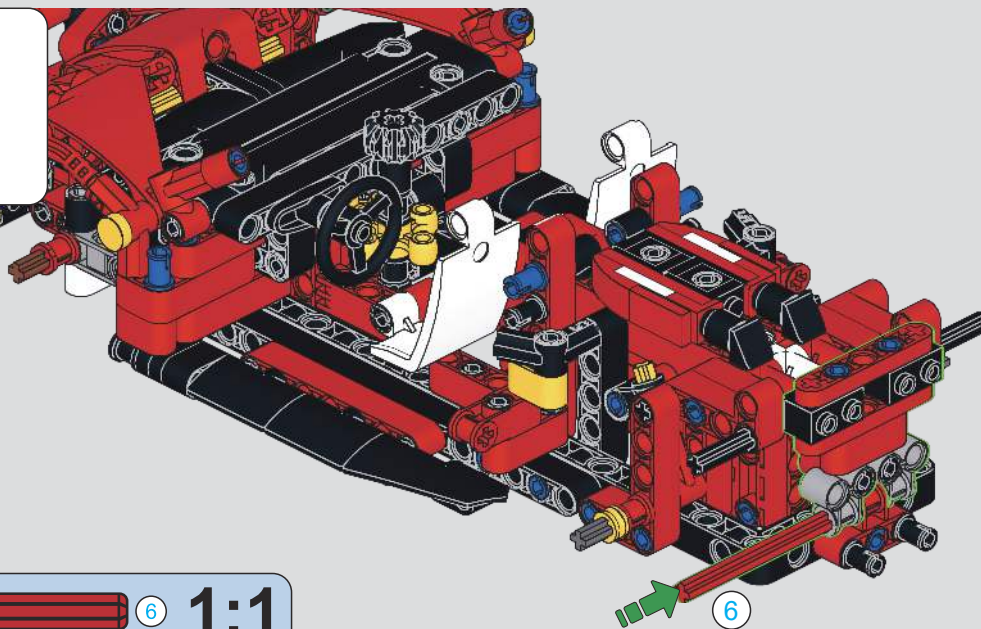

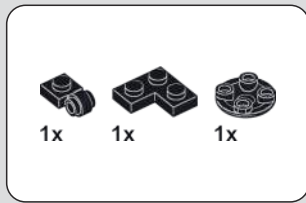

142

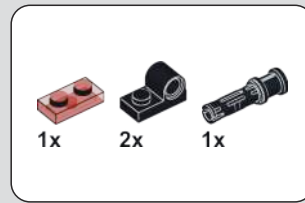
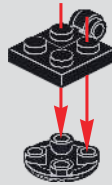

143

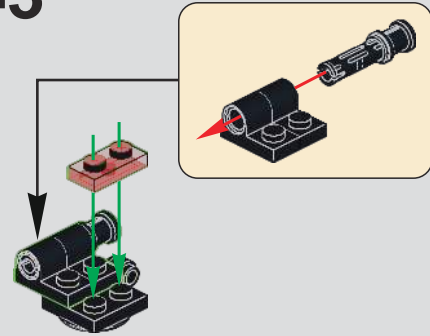

144

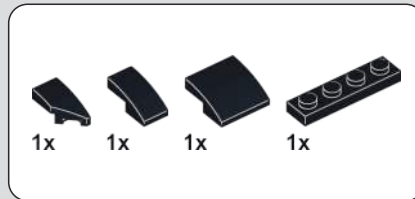

145

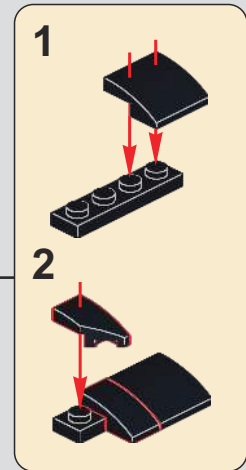
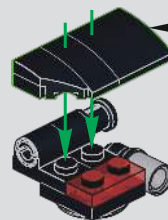

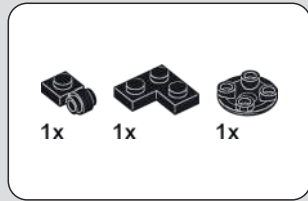

146

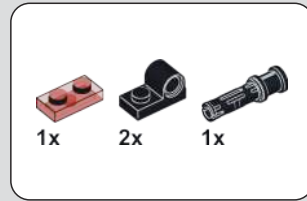
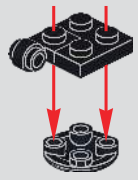

147

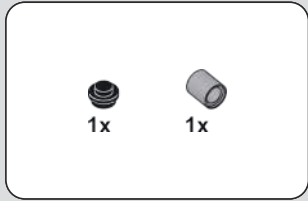
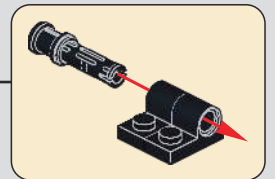
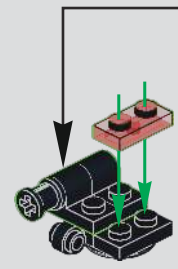

148

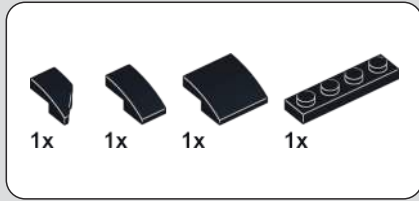
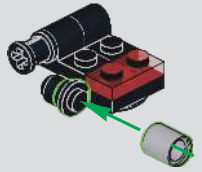

149

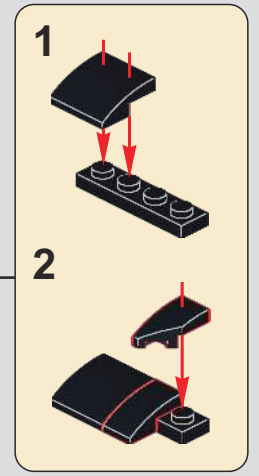
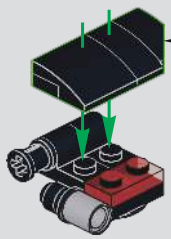

150

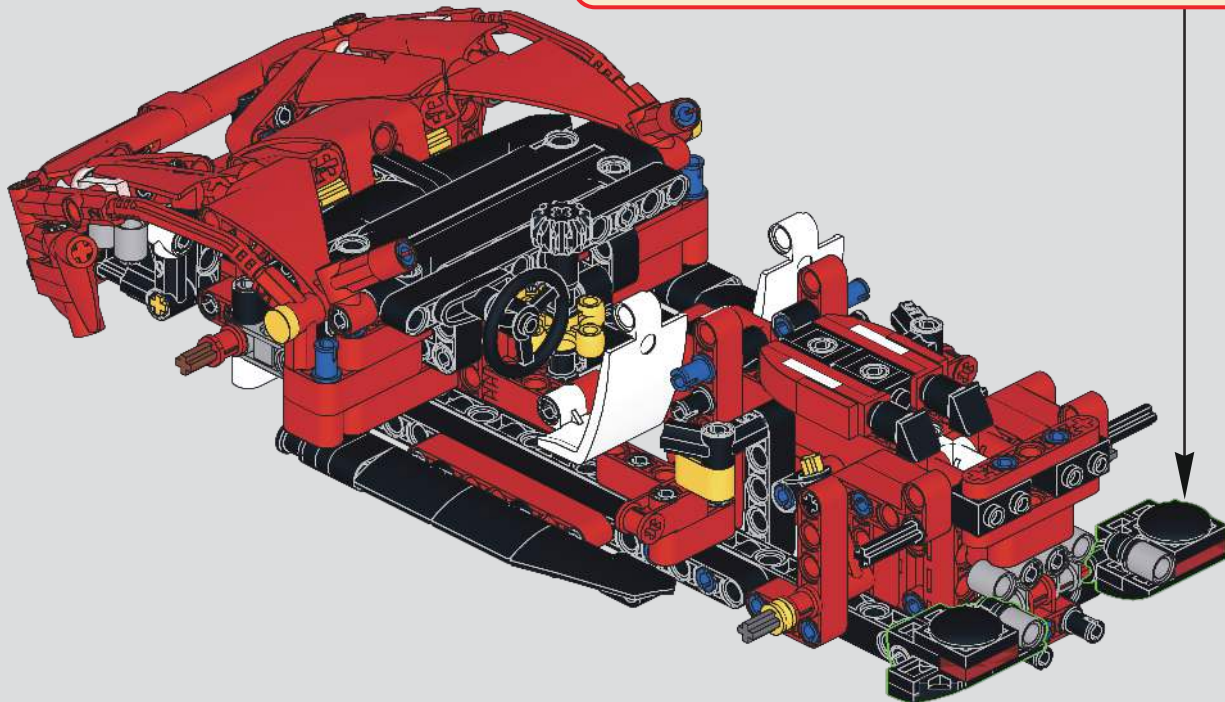
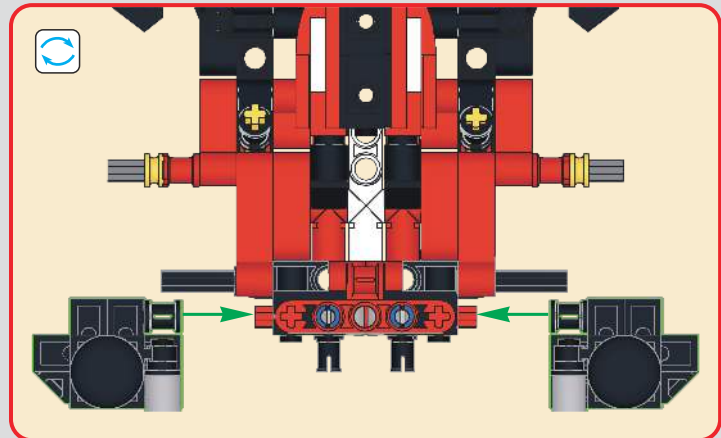

(Technic Pin without Friction)  
(光滑栓)

4x    2x    2x    1x

11

151

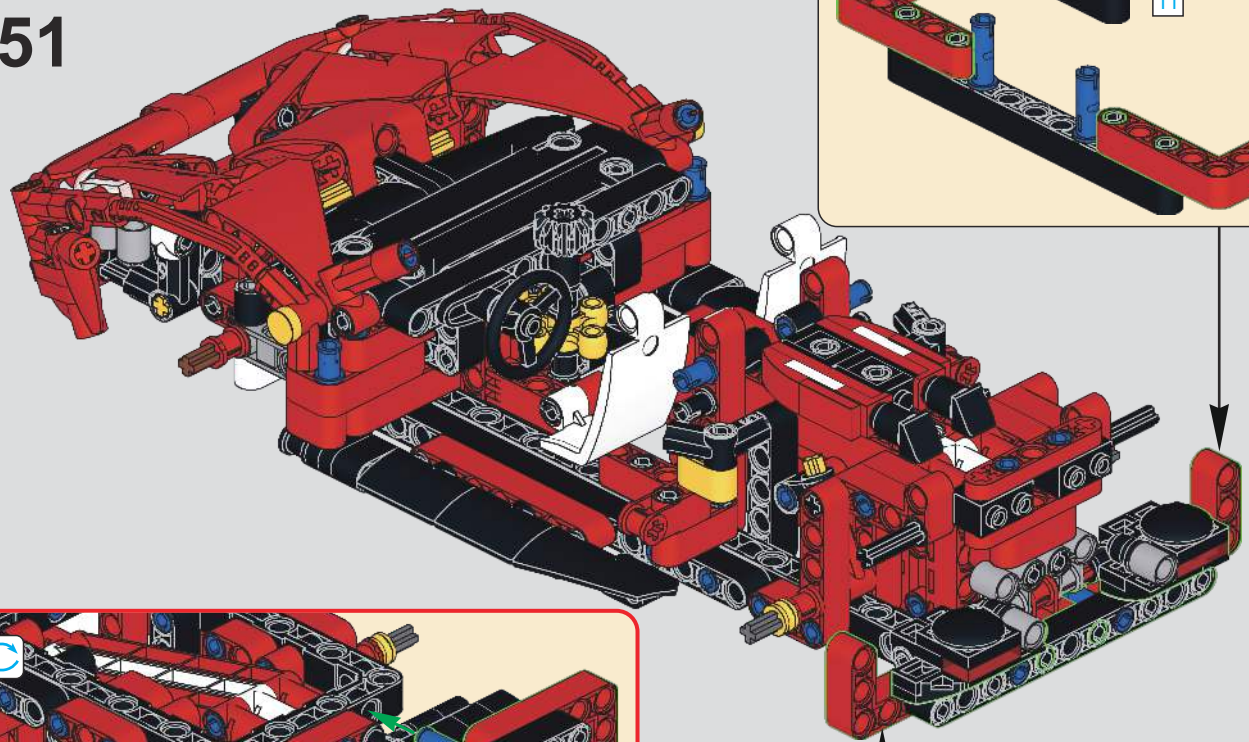

1

2

11

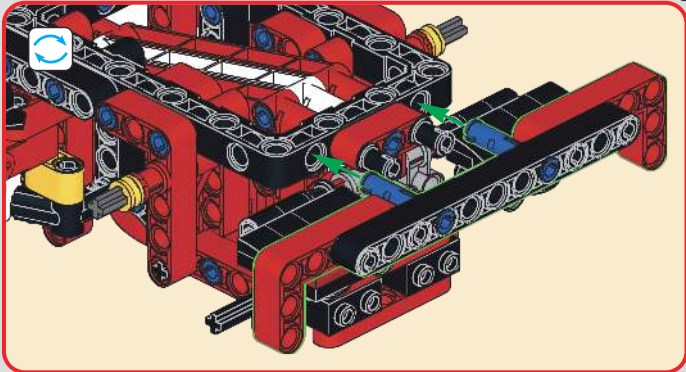

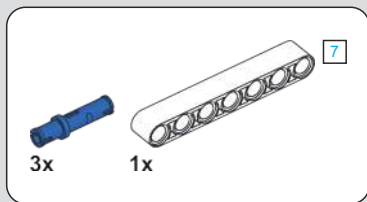
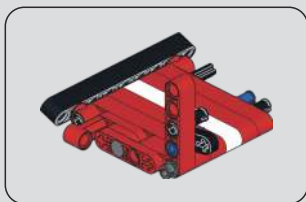

152

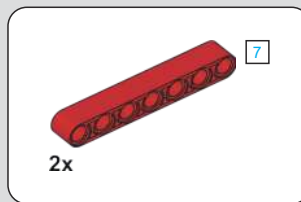
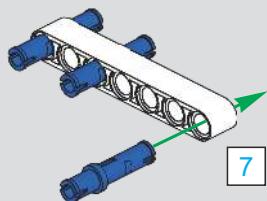

153

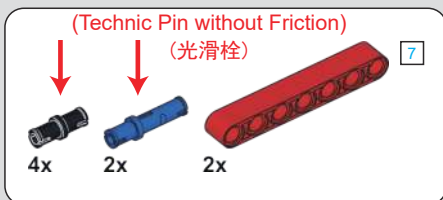
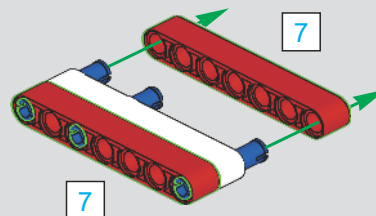

154

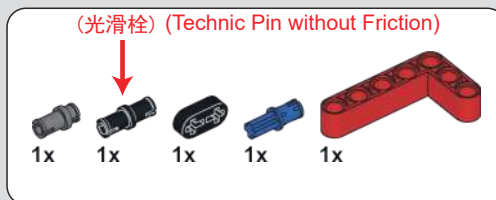
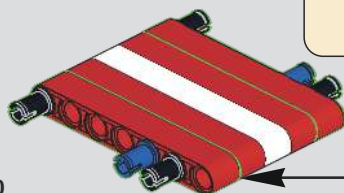
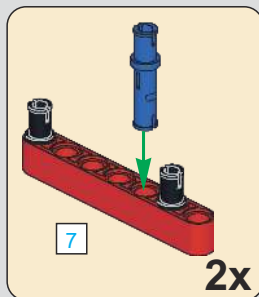

155

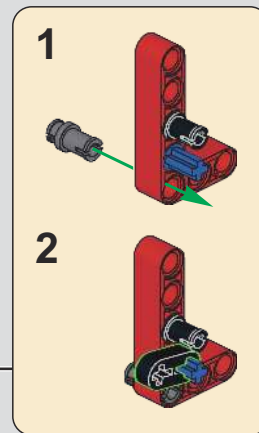
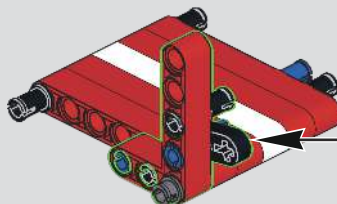

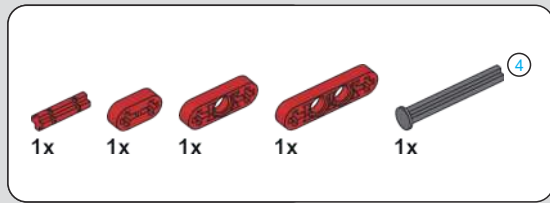

156

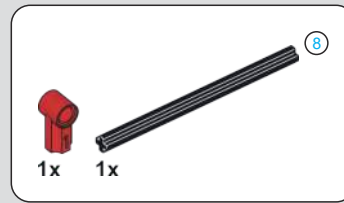
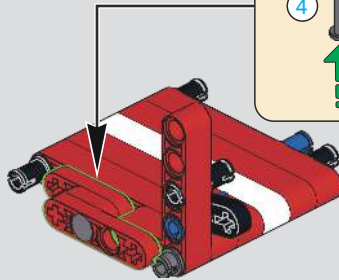
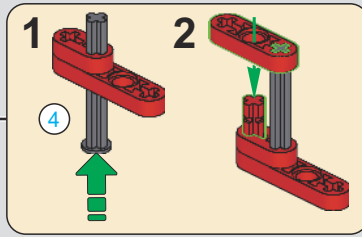

157

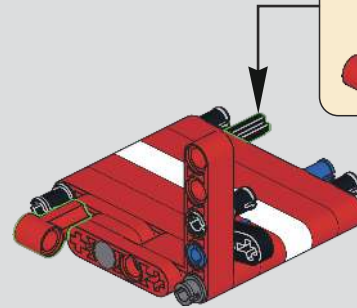
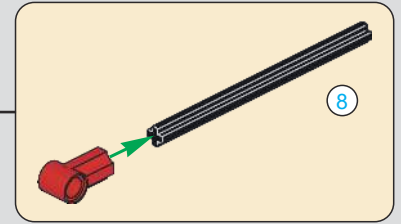

158

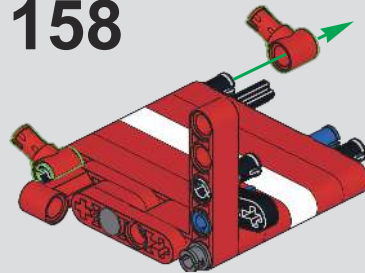

159

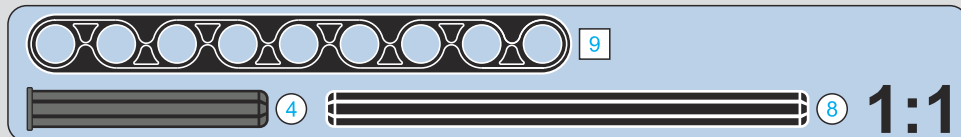
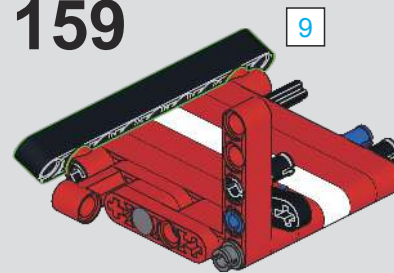

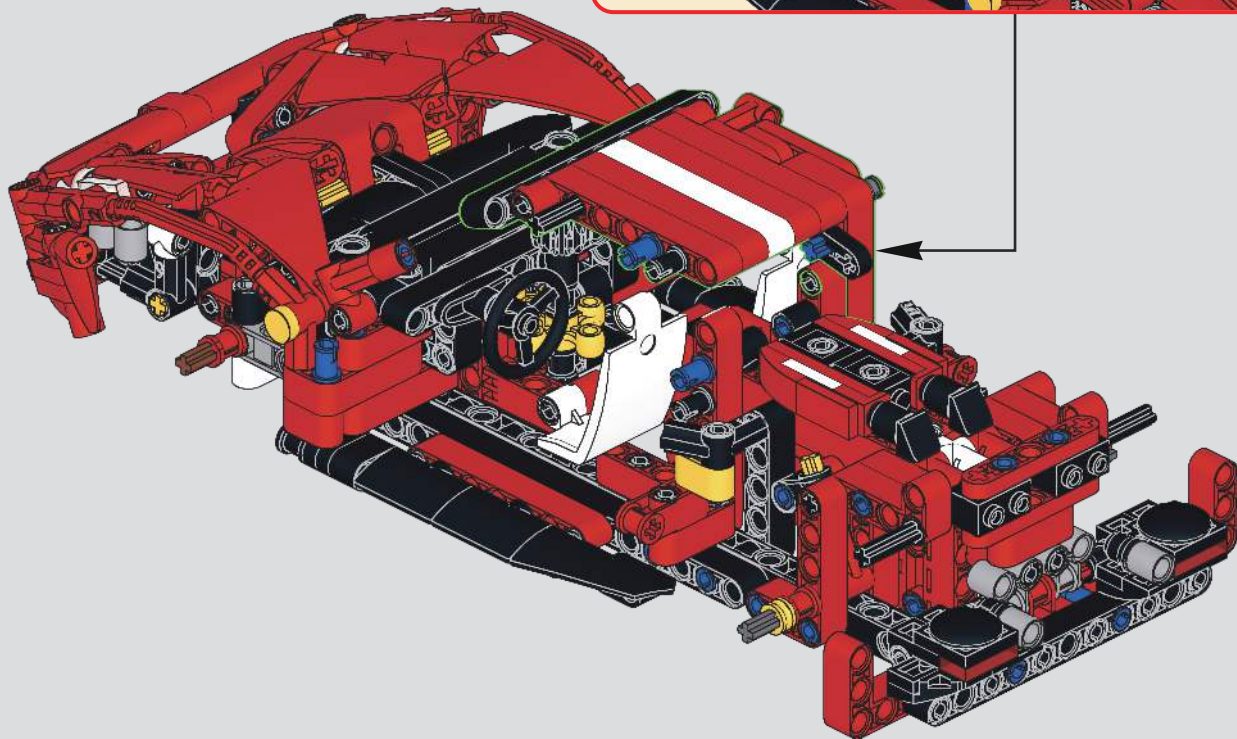
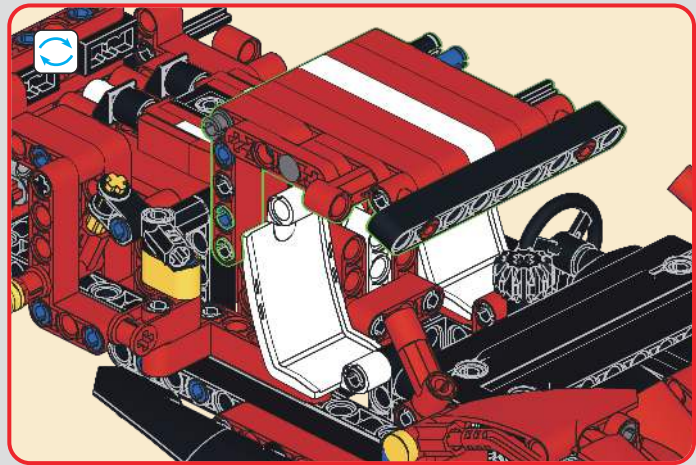

(Technic Pin without Friction)  
(光滑栓)



161

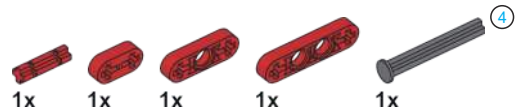
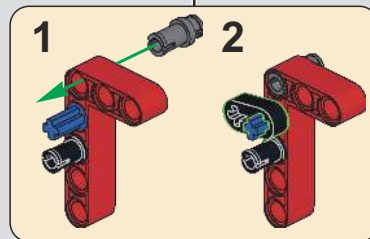
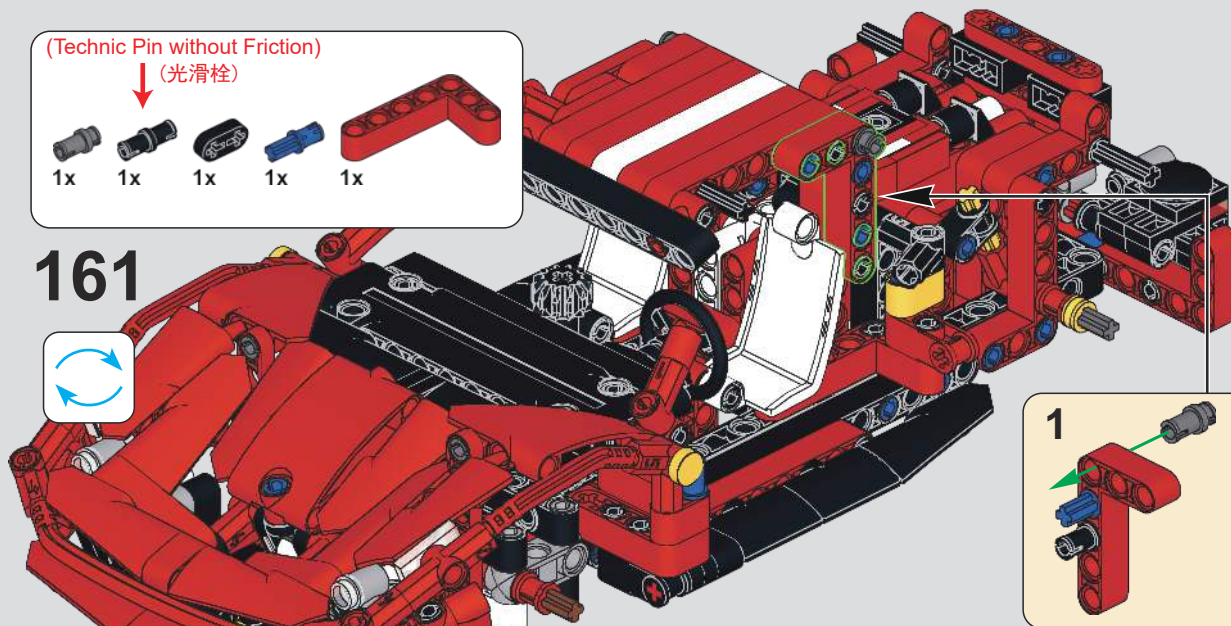

162

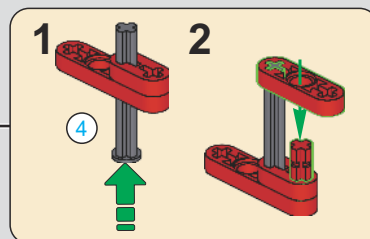
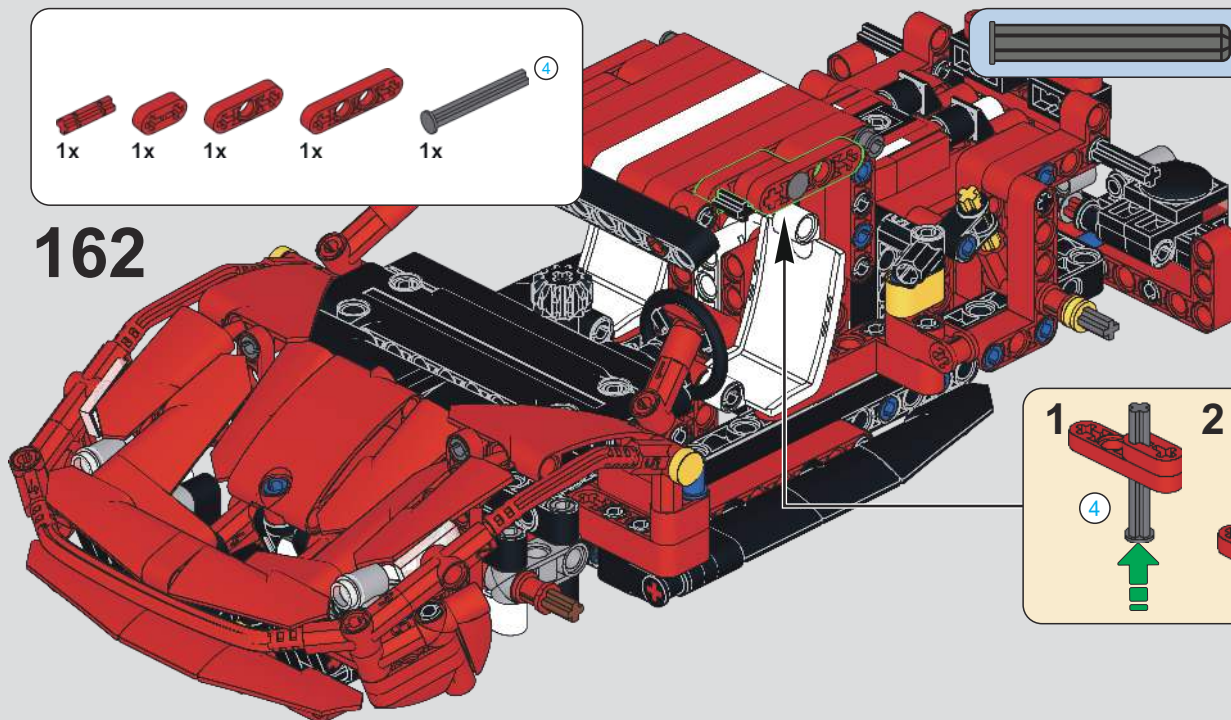



1x

163

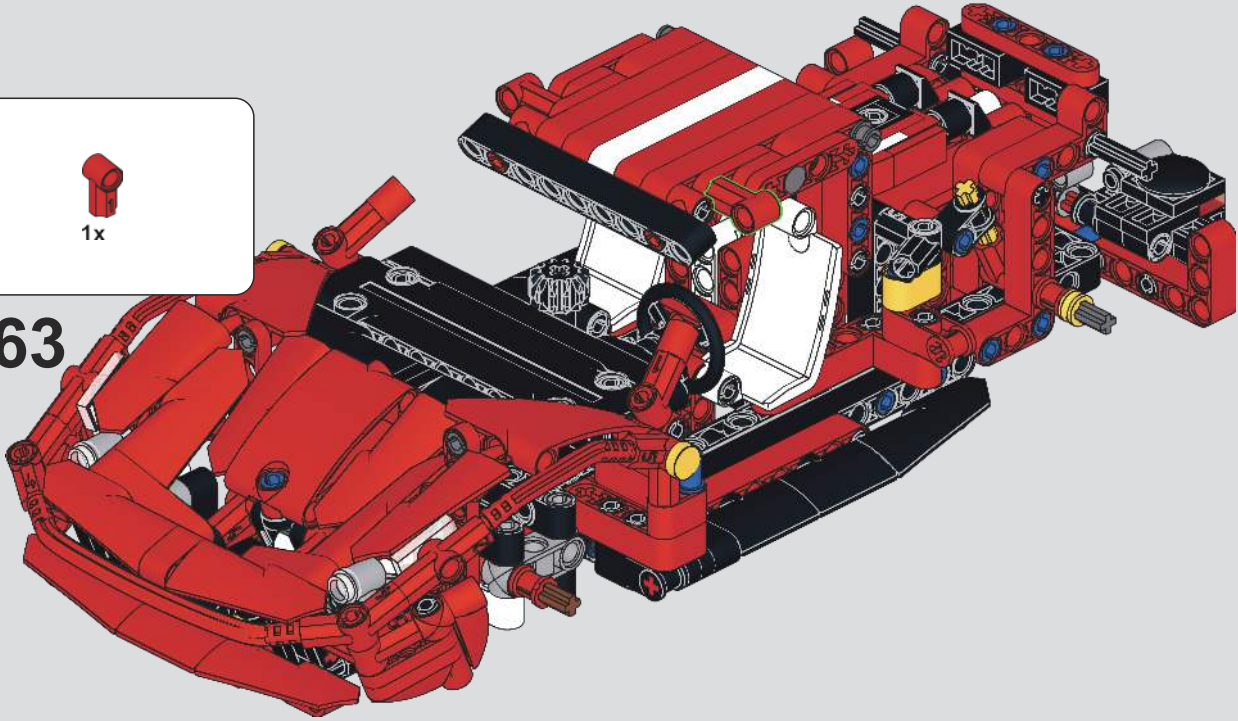

(Technic Pin without Friction)  
(光滑栓)



2x



2x

164

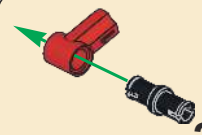
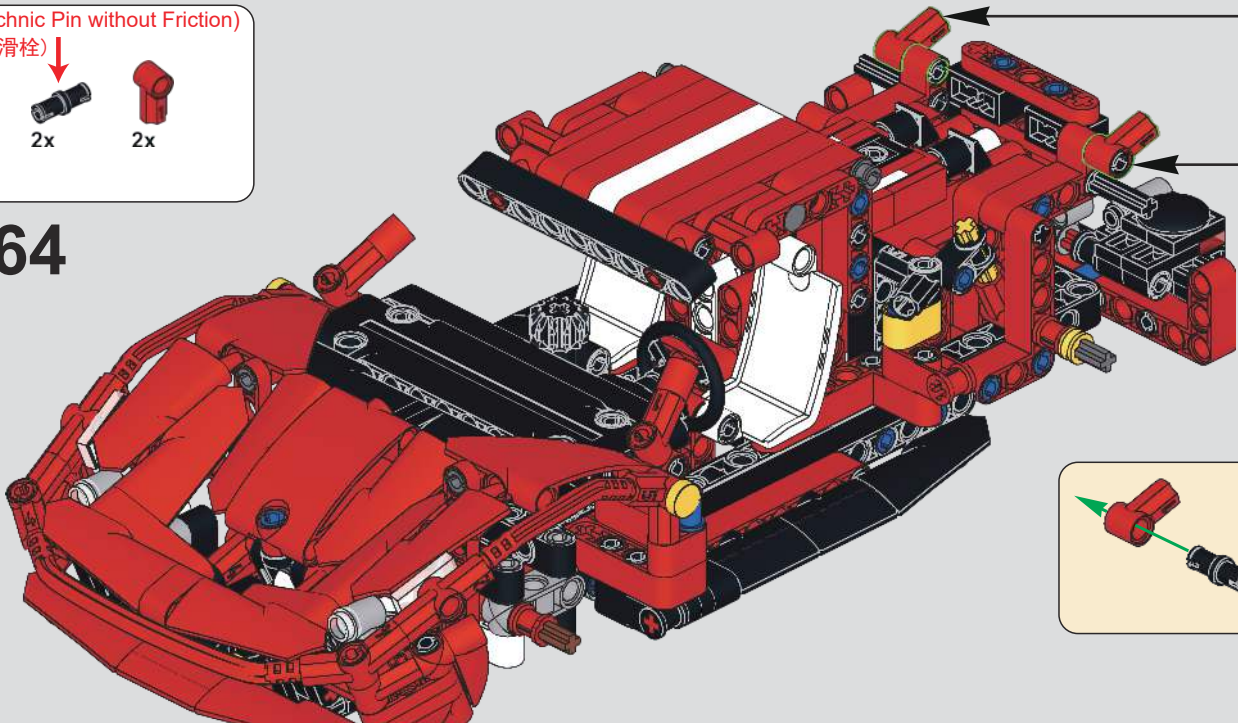

2x

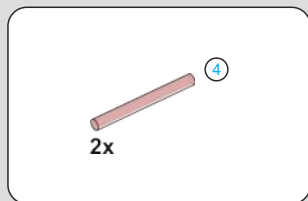

165

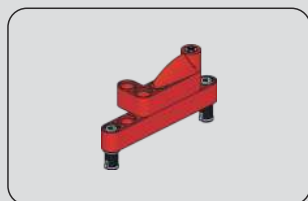
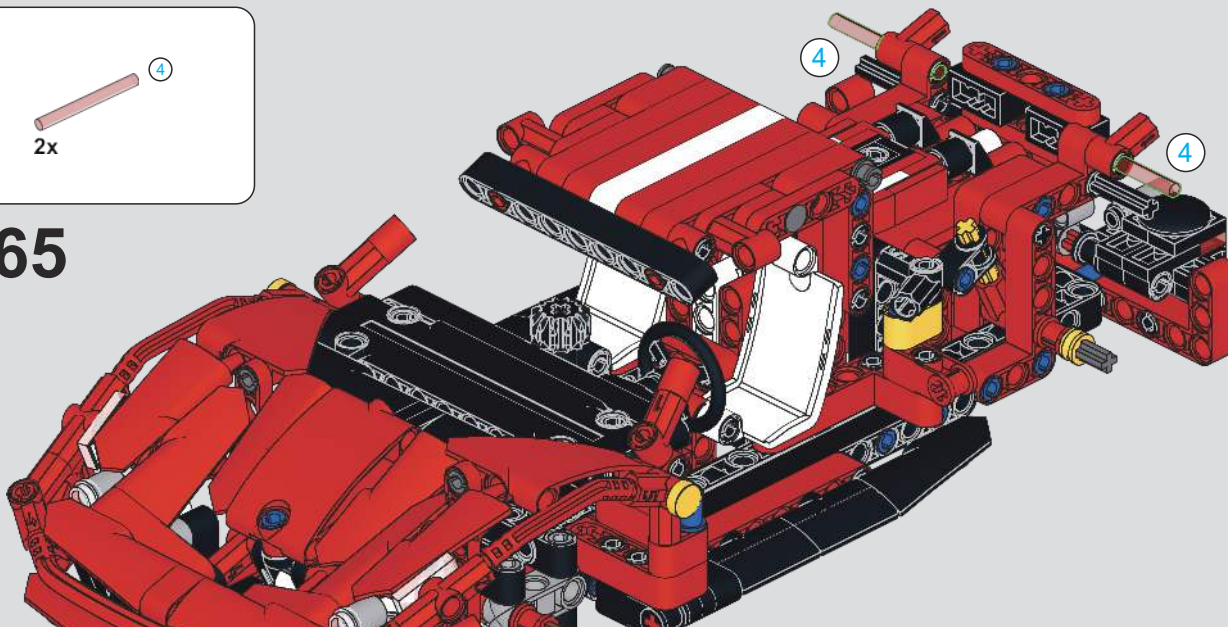

166

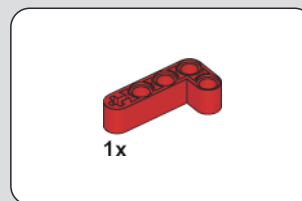

167

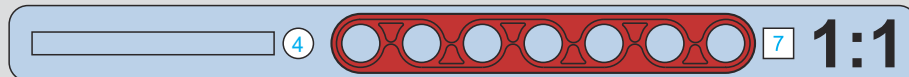
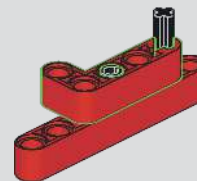
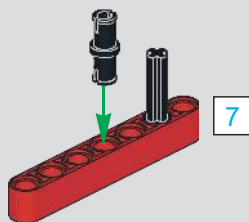

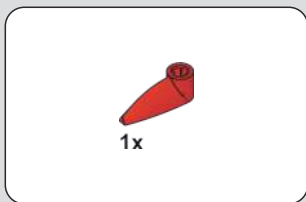

168

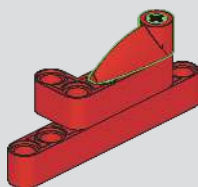

169

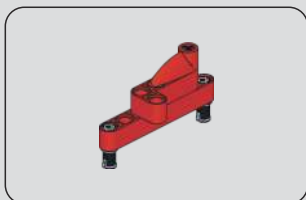
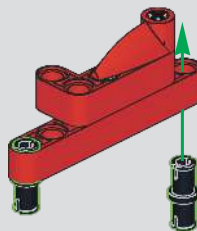

170

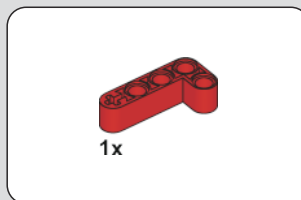

171

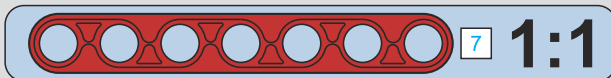
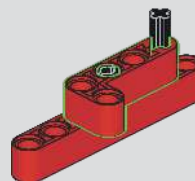
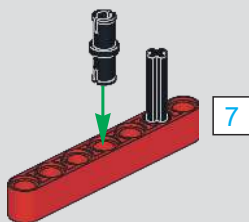

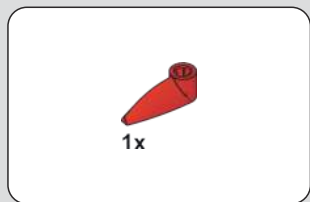

1x

172

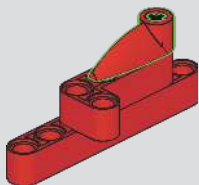

2x

(光滑栓)  
(Technic Pin without Friction)

173

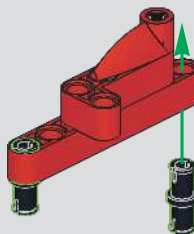

174

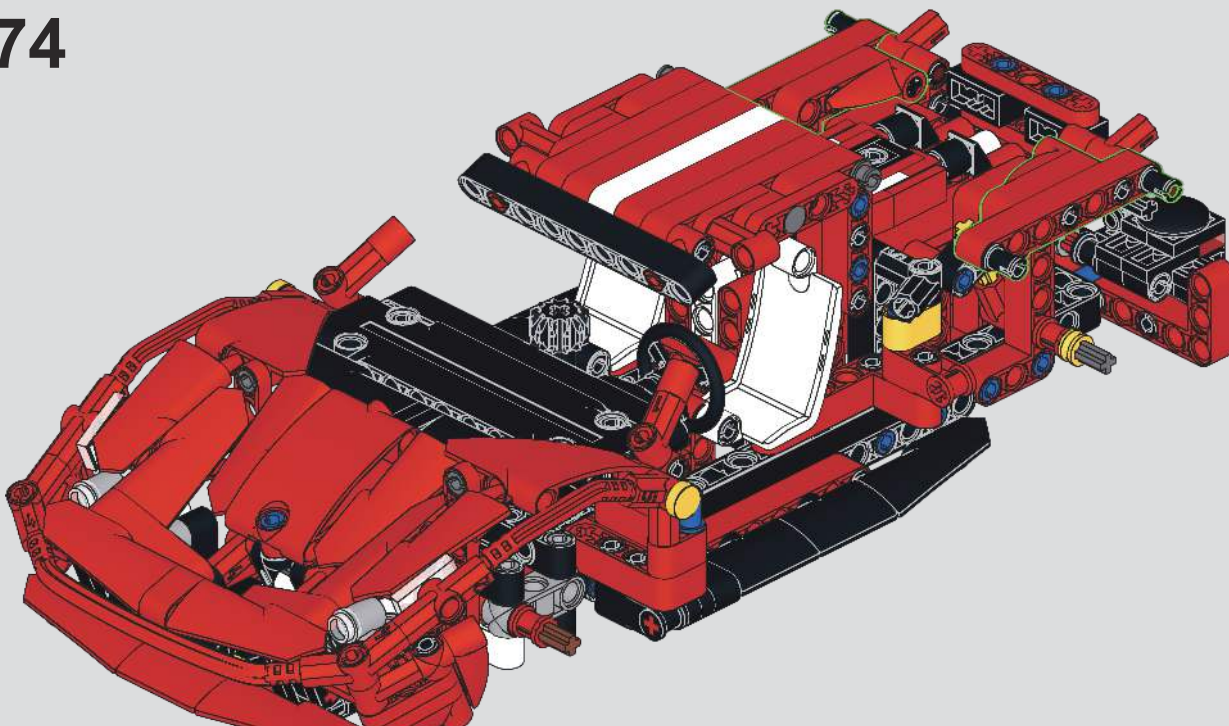



175

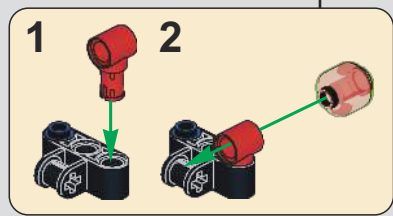
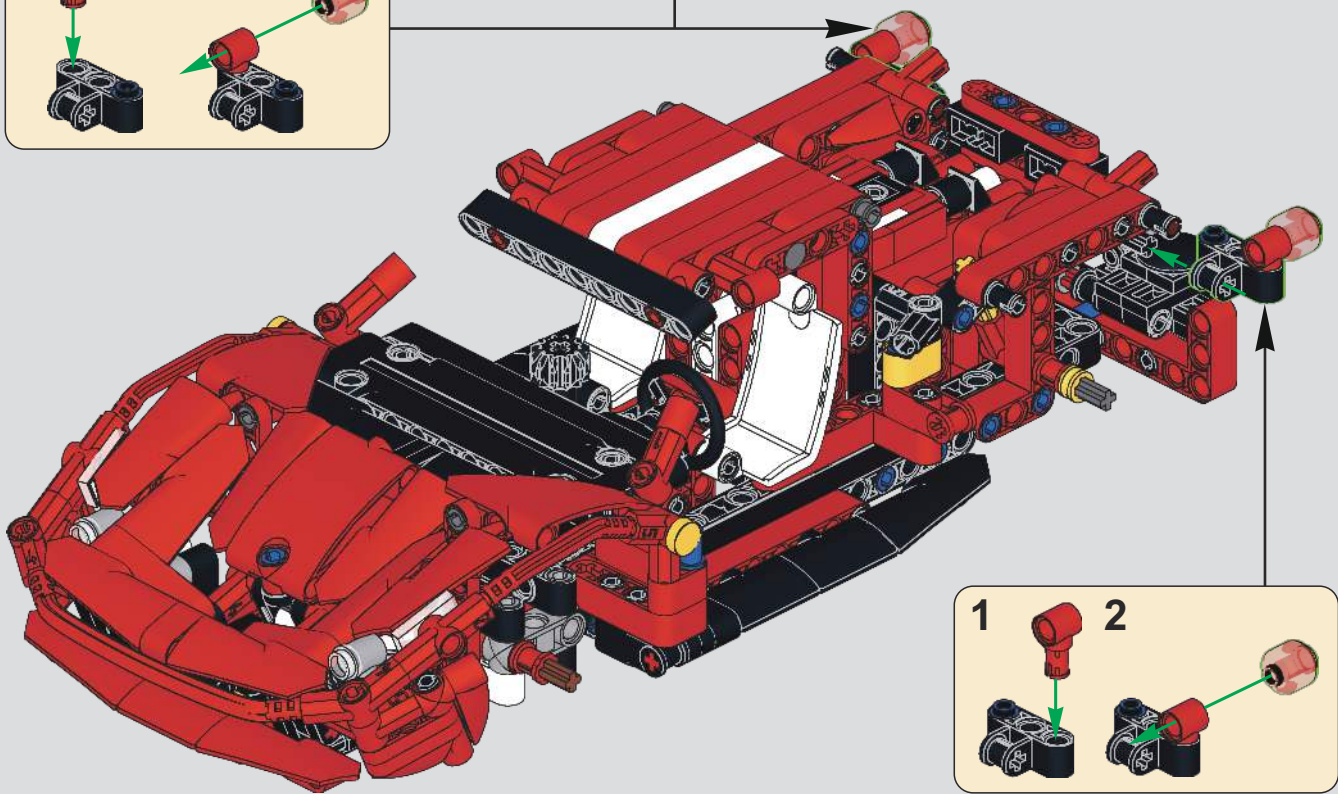
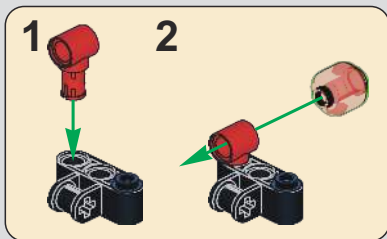
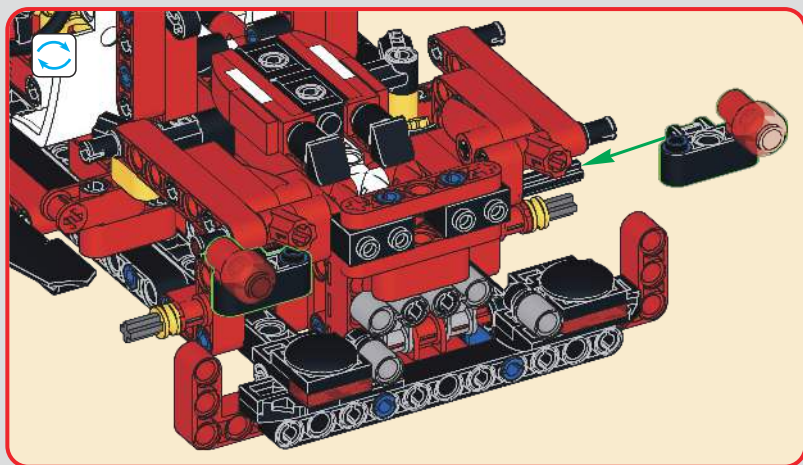

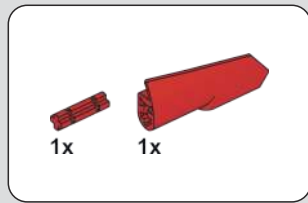
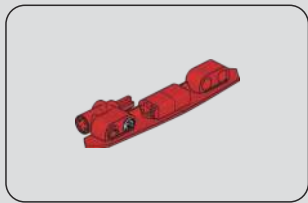

176

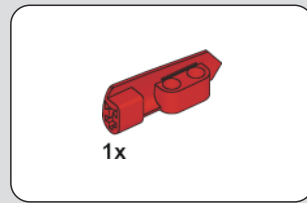

177

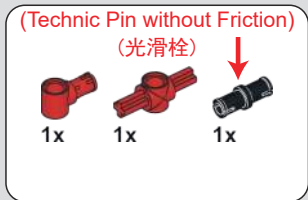
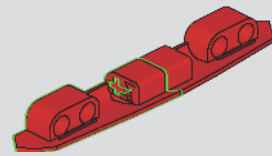
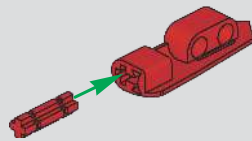

178

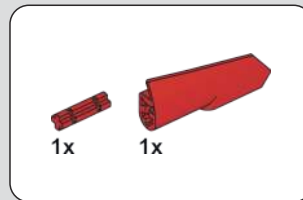
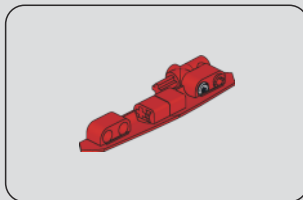

179

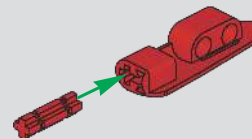
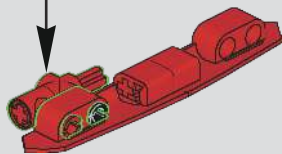
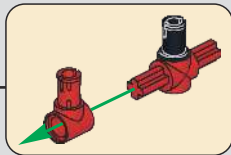

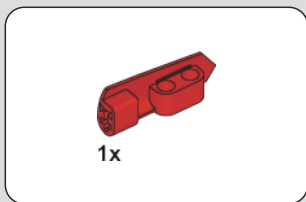

180

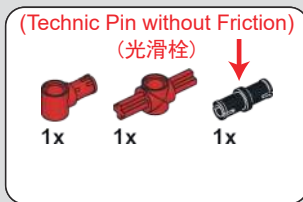

181

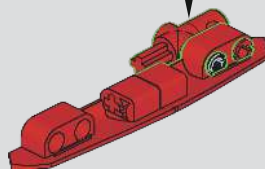
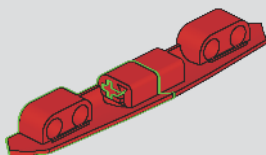
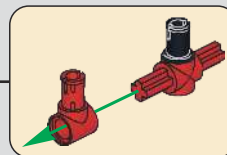

182

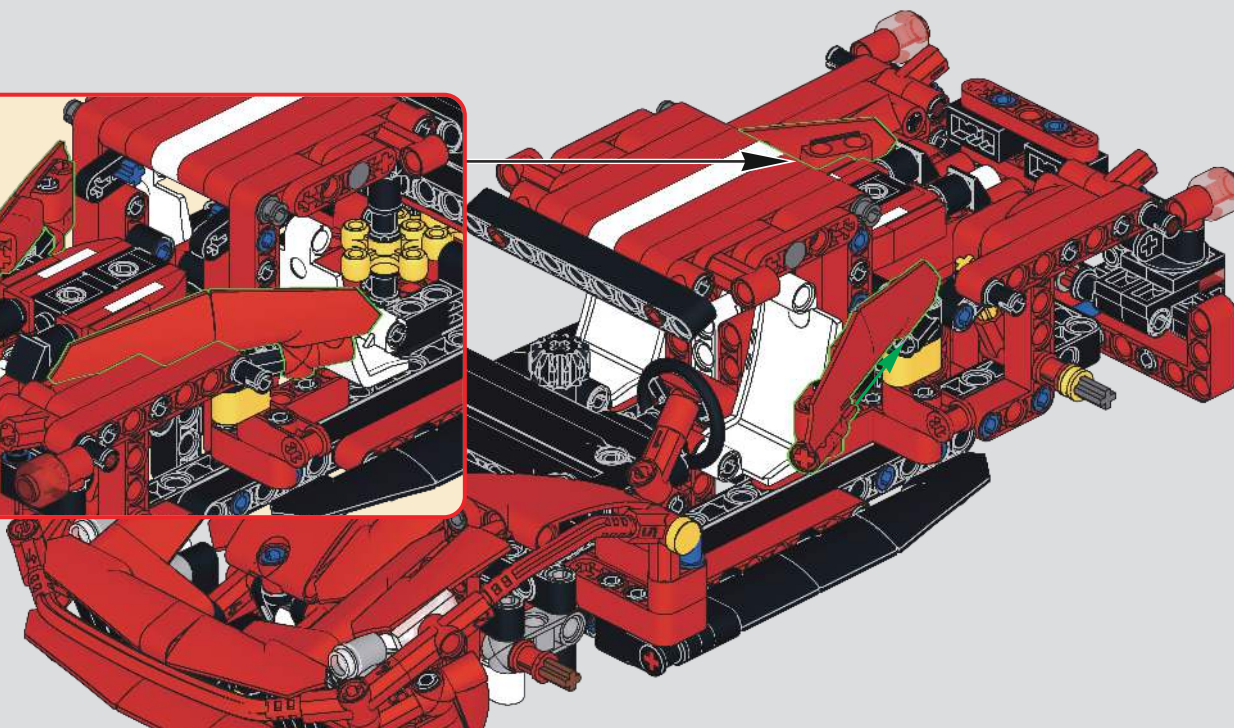
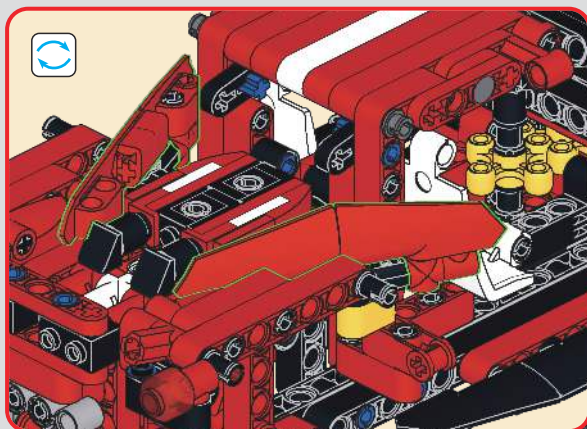

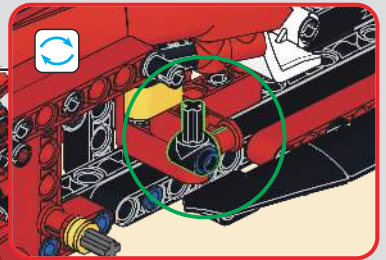
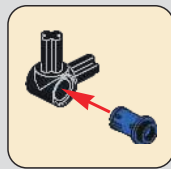
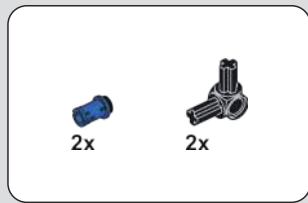

183

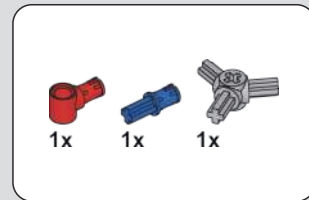
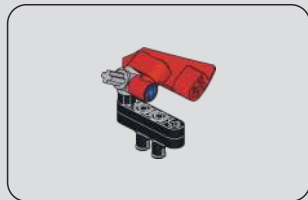
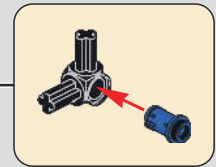
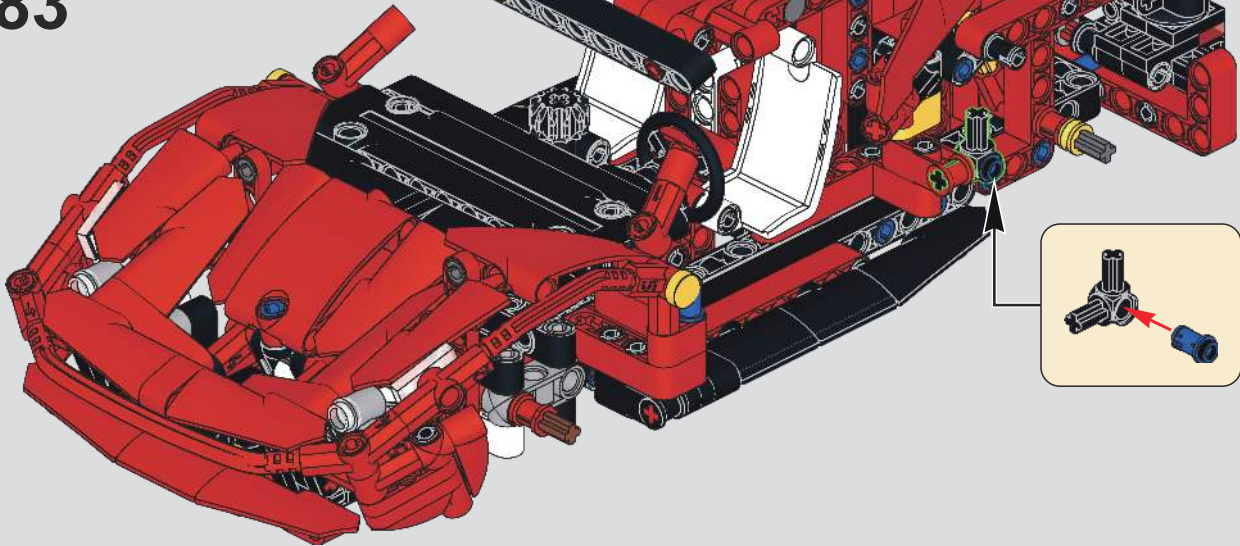

184

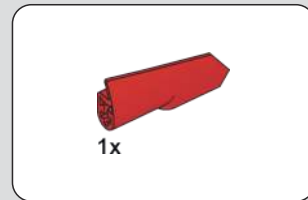
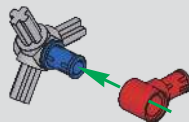

185

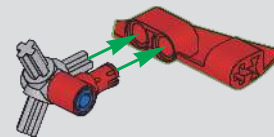



186

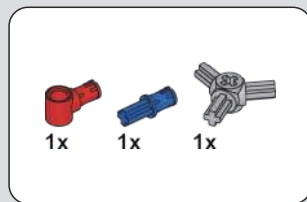
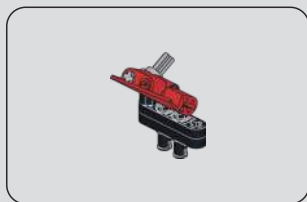
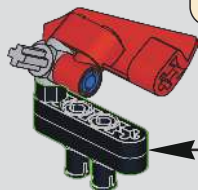
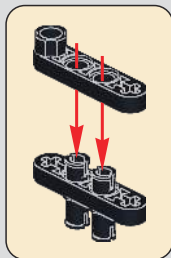

187

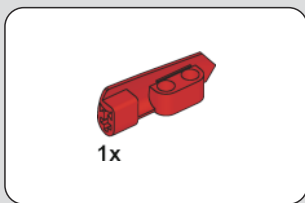
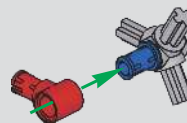

188

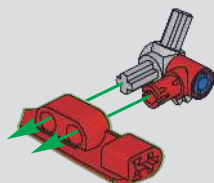

189

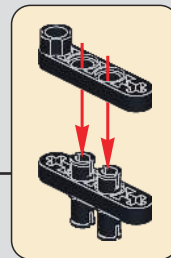
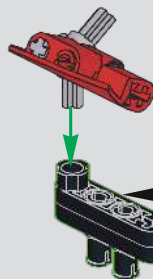

# 190

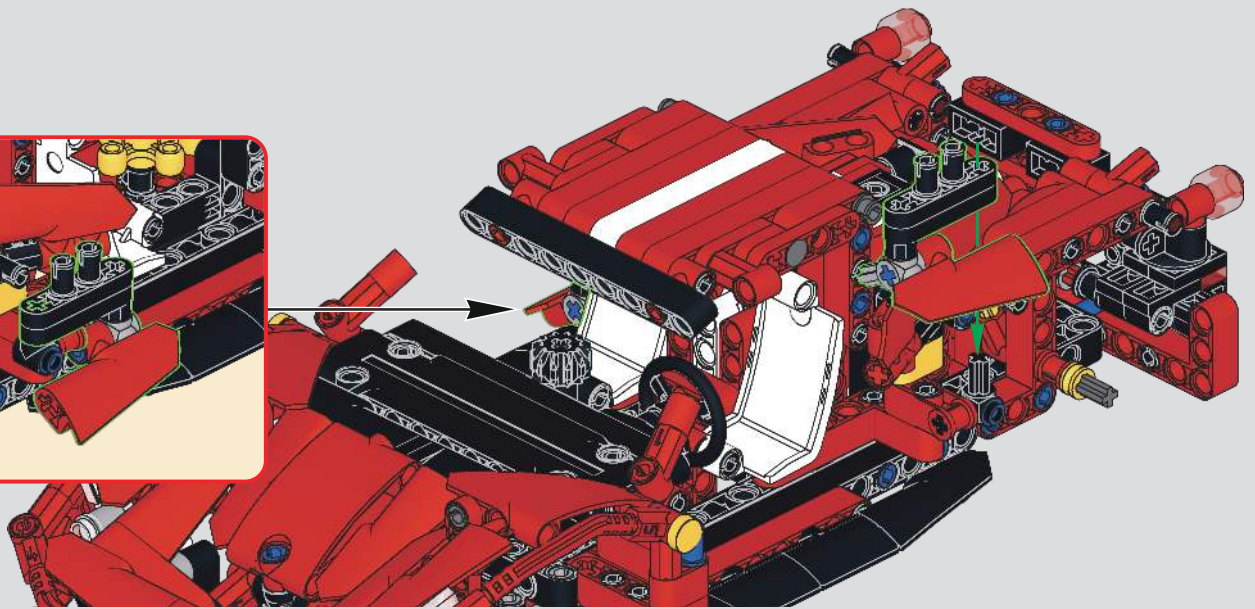
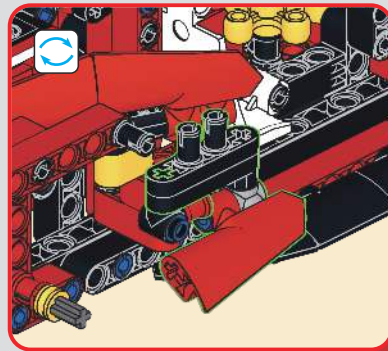

# 191

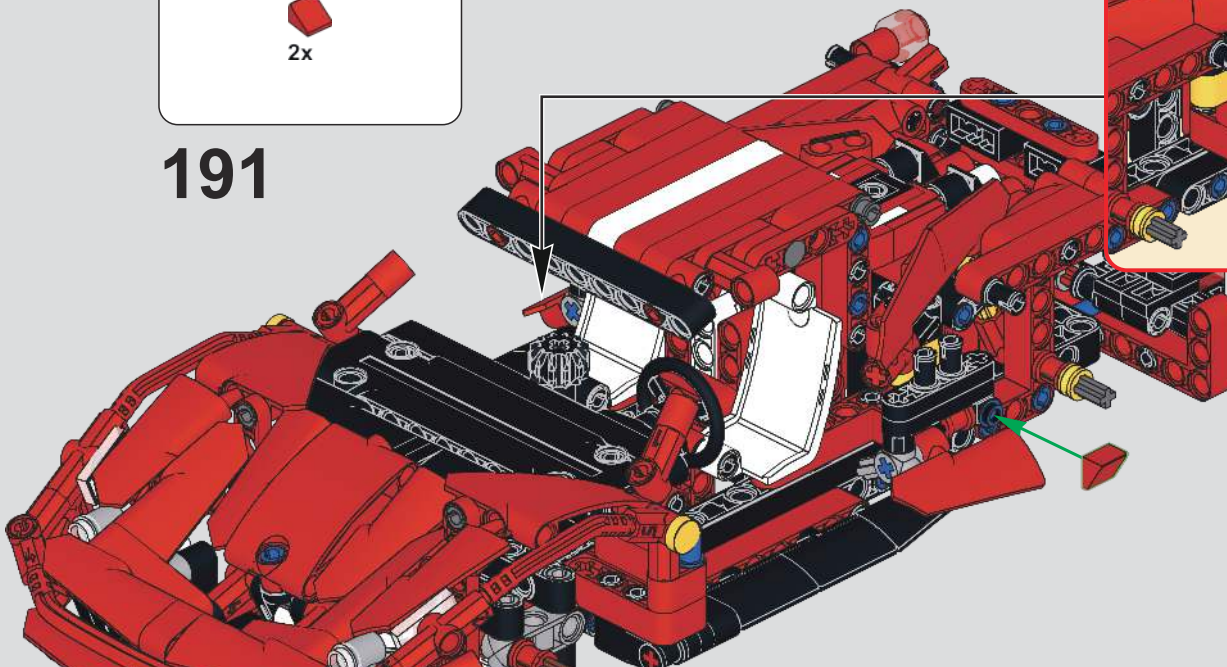
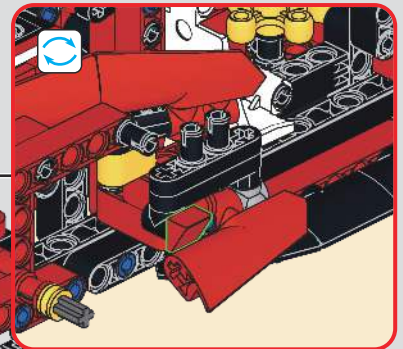

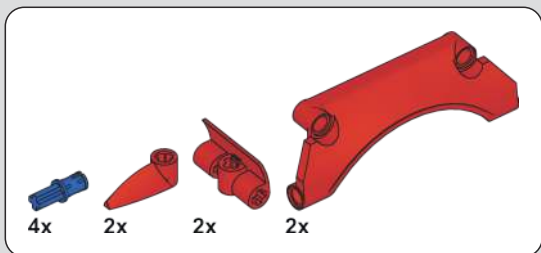

192

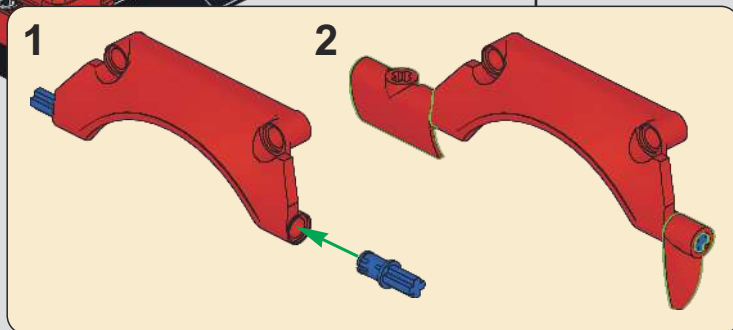
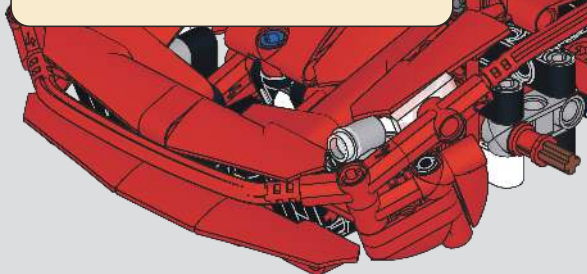
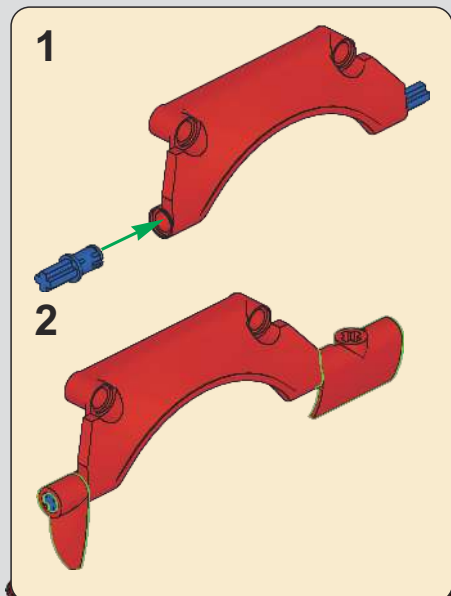
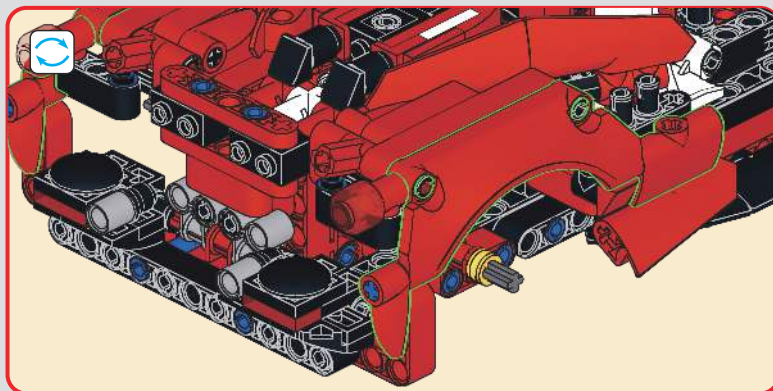

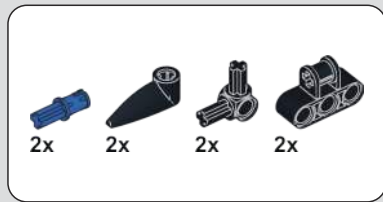

193

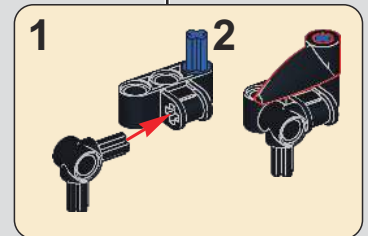
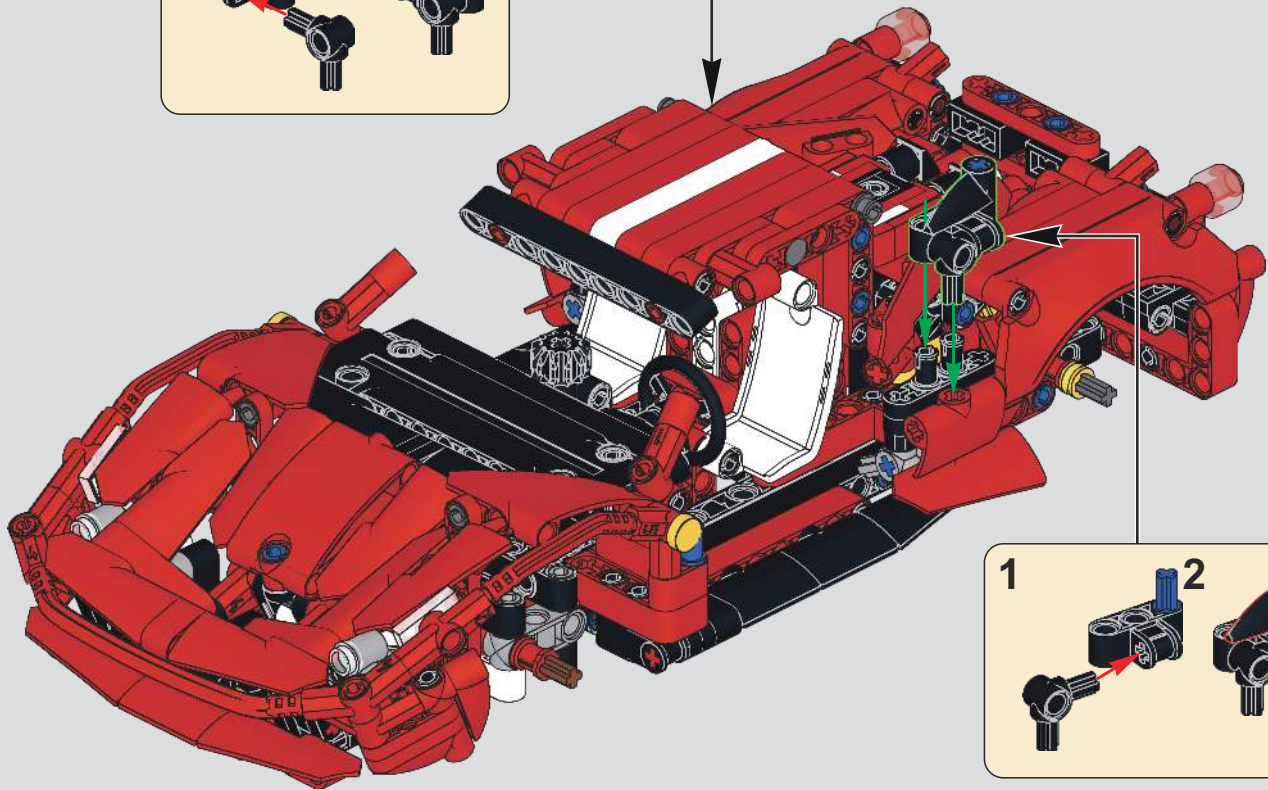
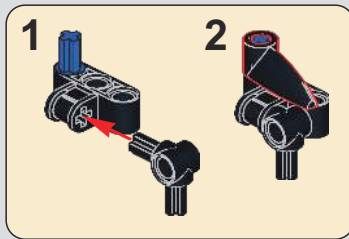
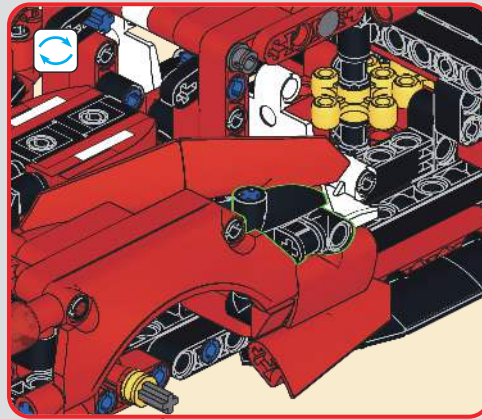

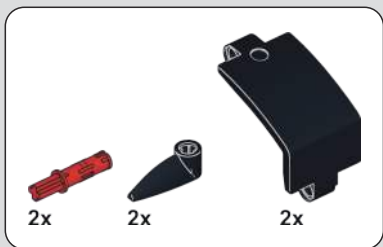

194

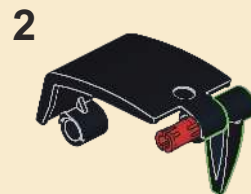
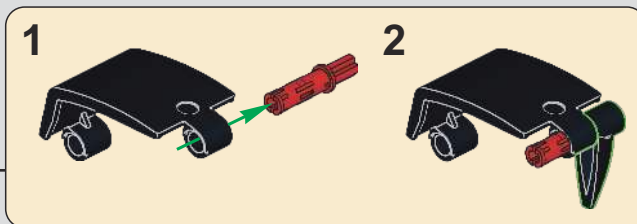
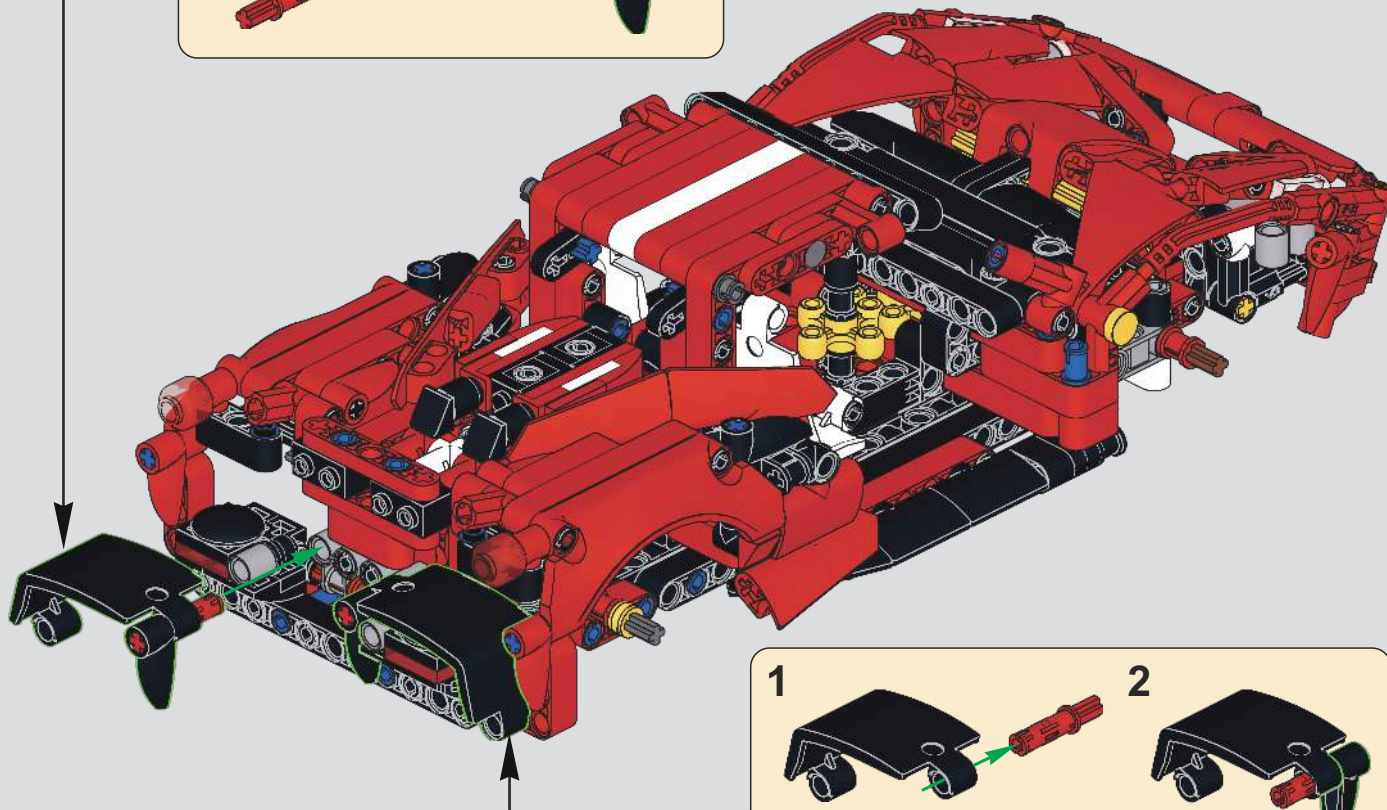
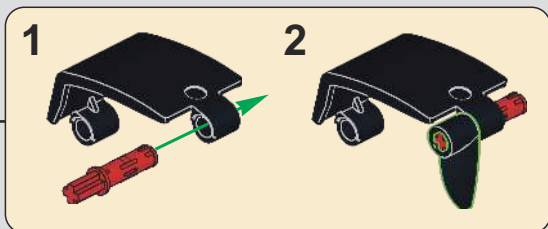



195

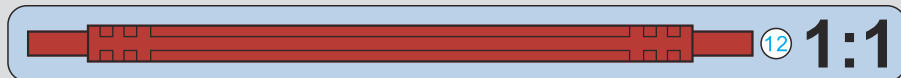
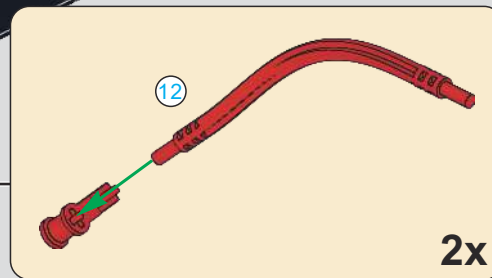
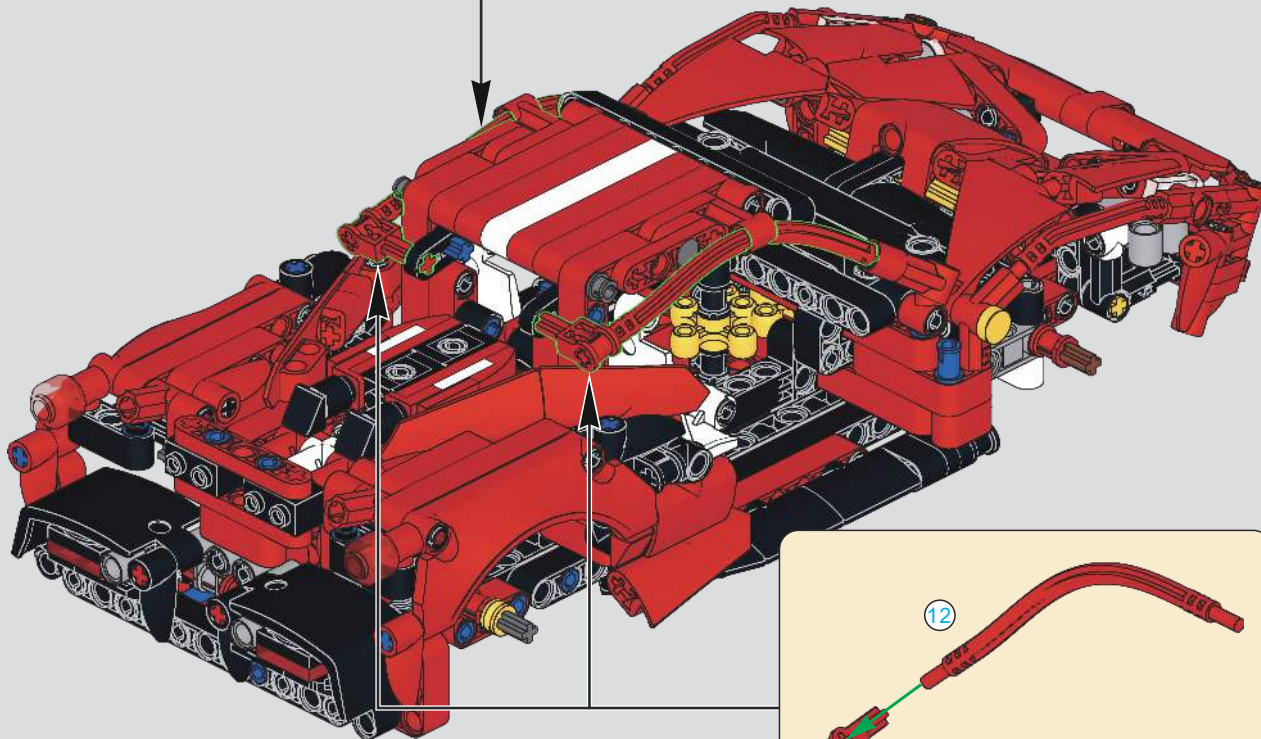
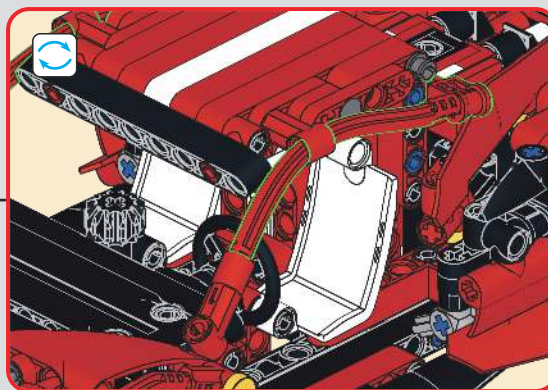

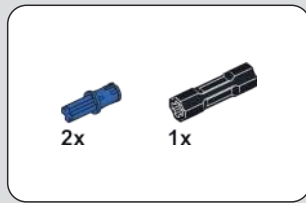

196

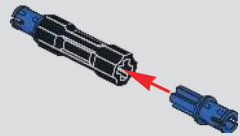

197

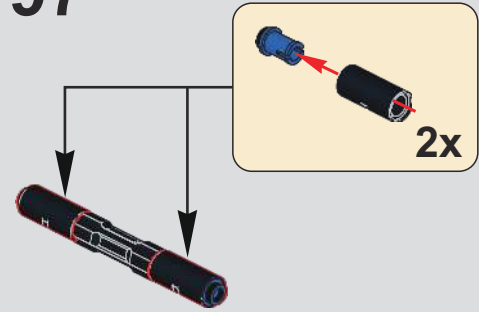

198

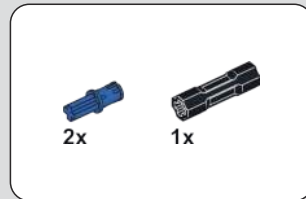

199

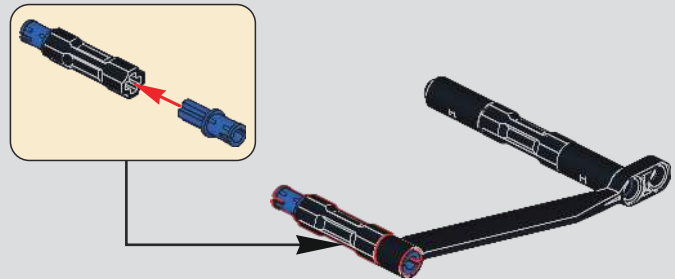

200

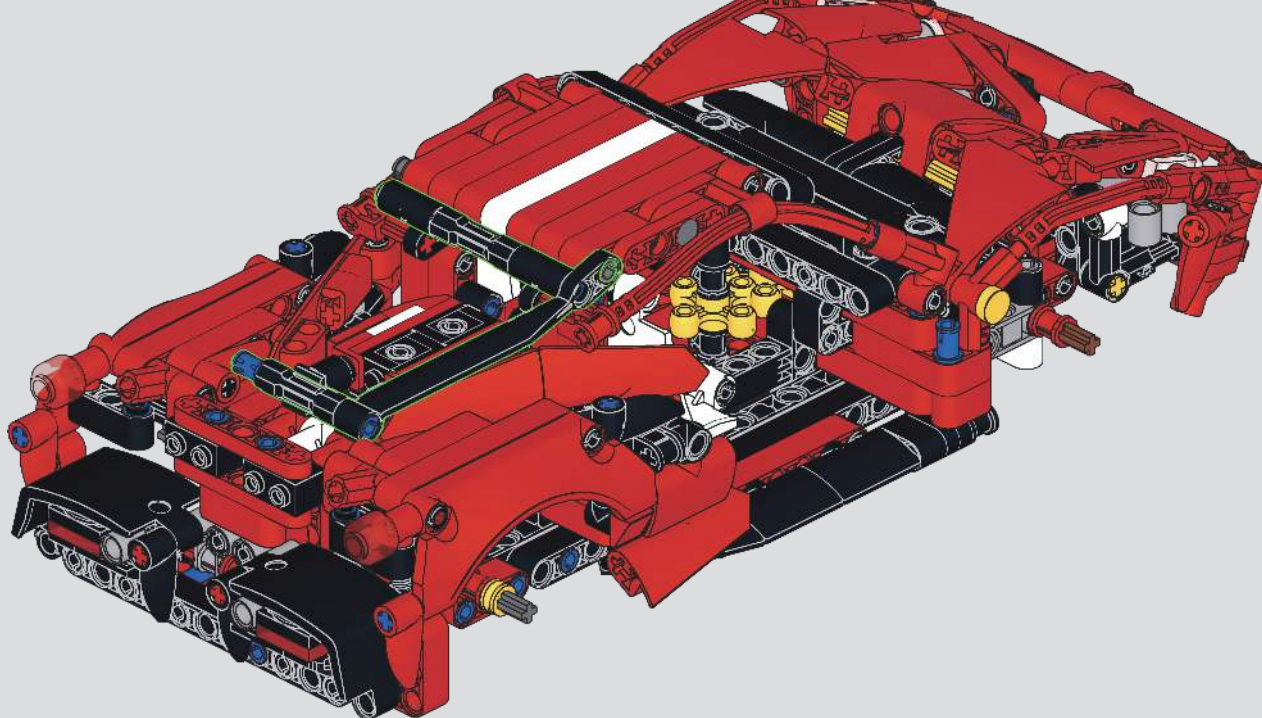

201

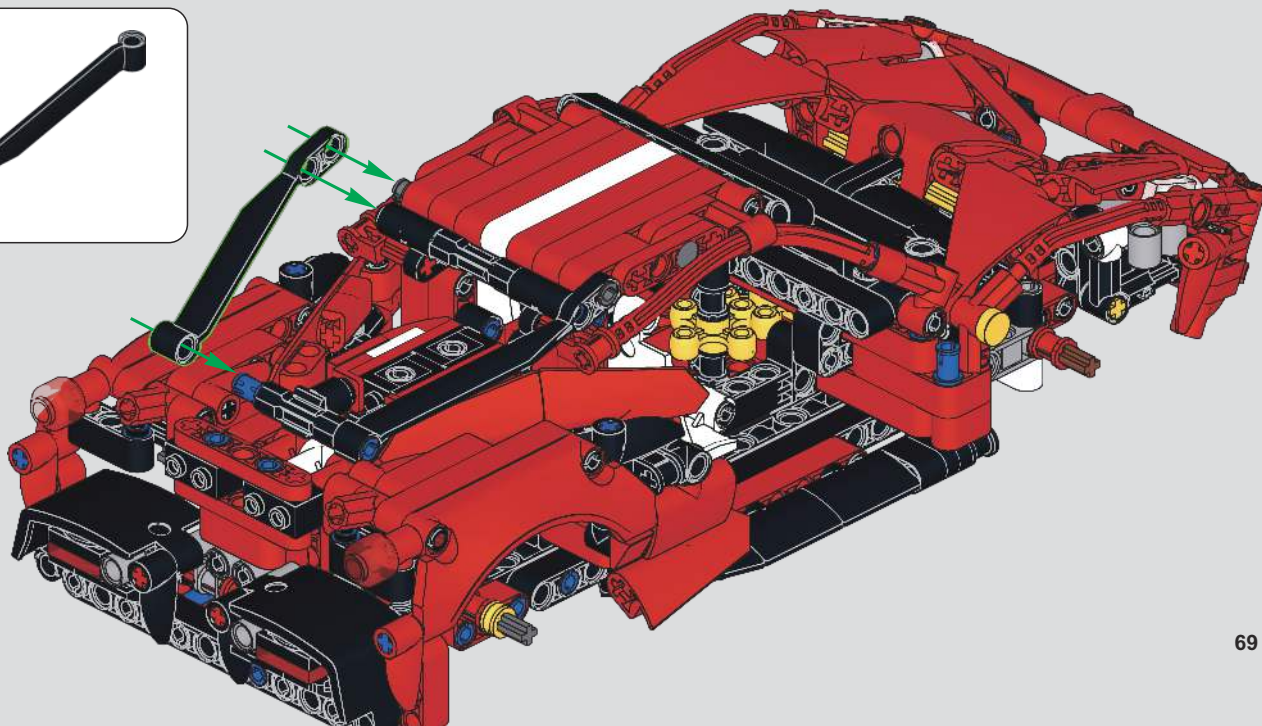

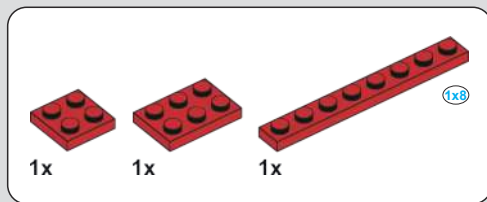
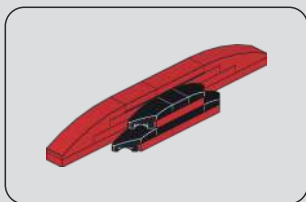

202

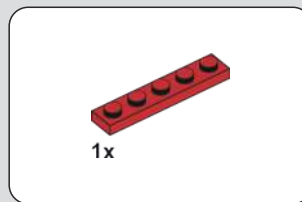

203

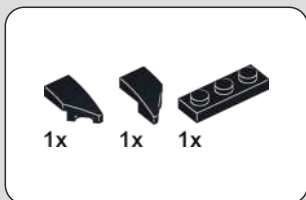
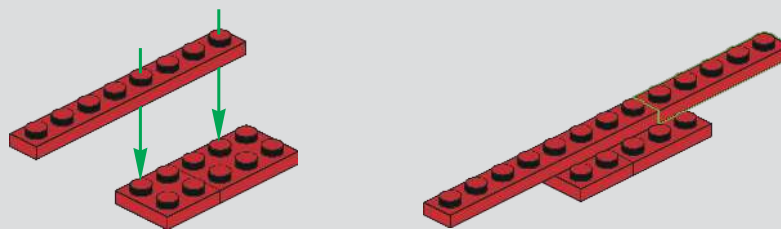

204

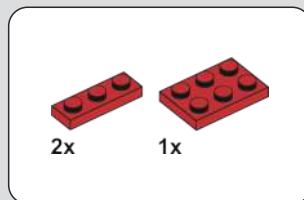

205

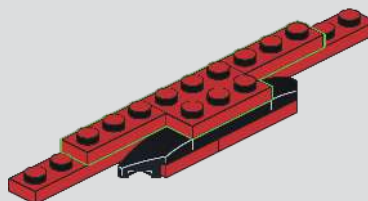
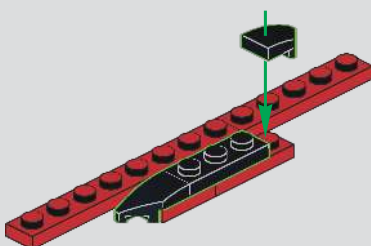

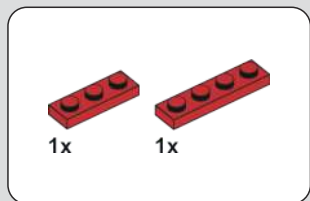

206

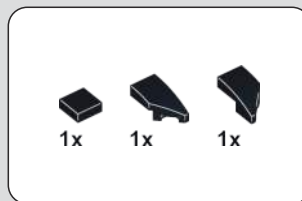
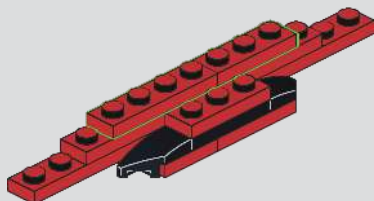

207

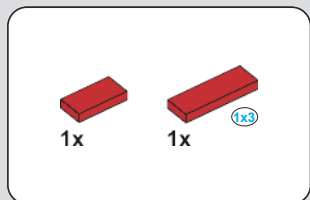
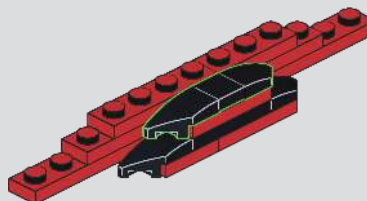

208

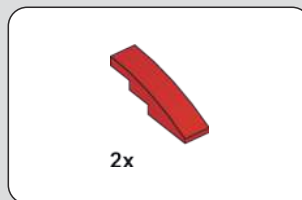
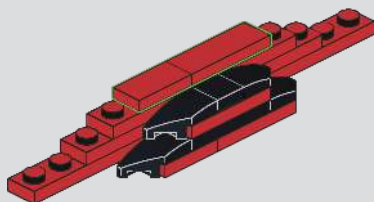

209

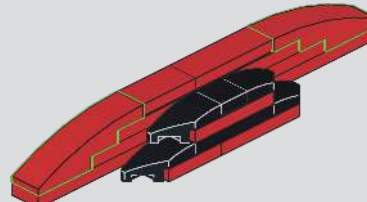

210

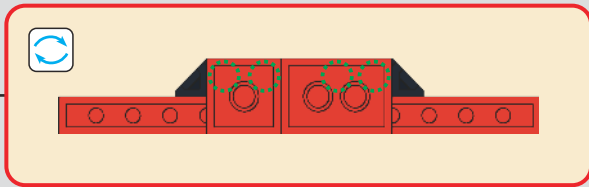
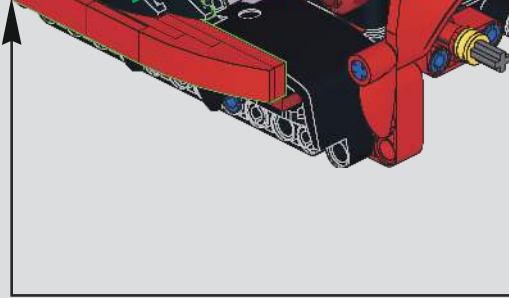
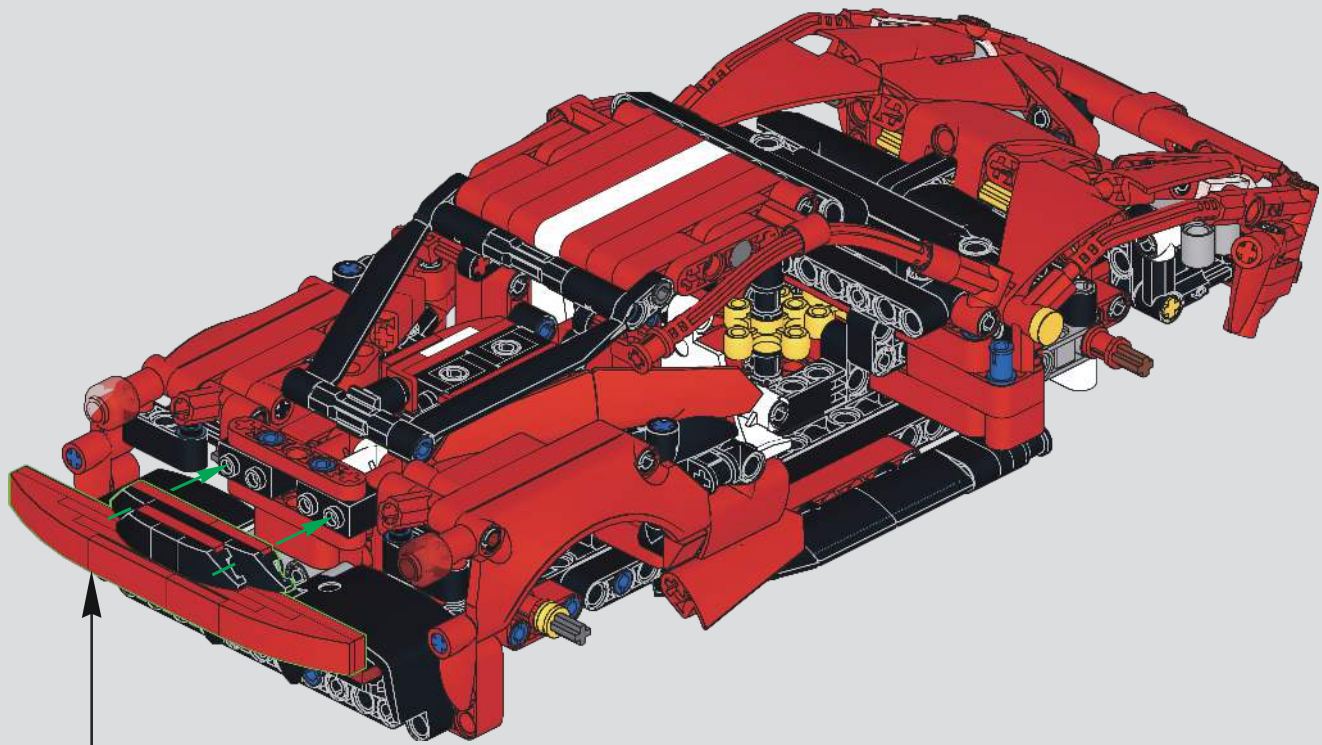

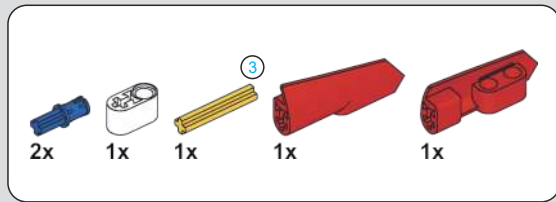

211

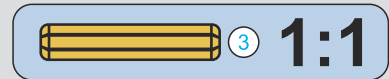
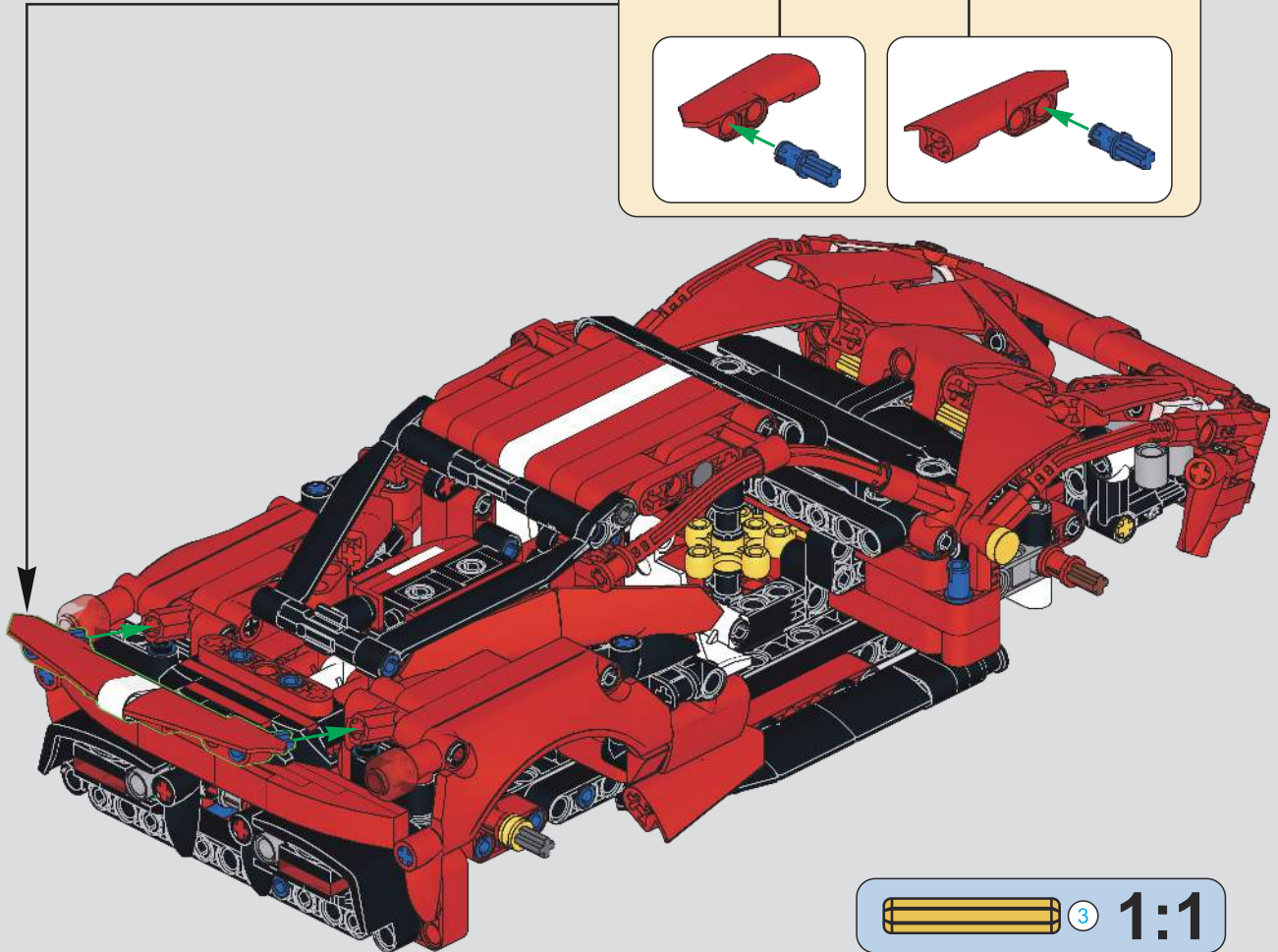
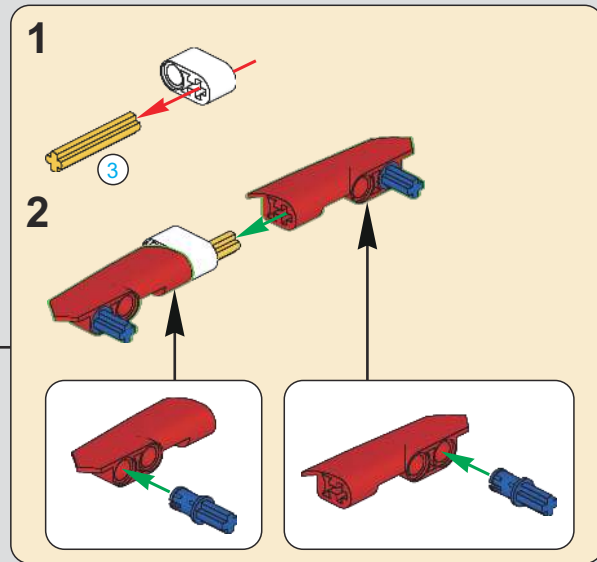

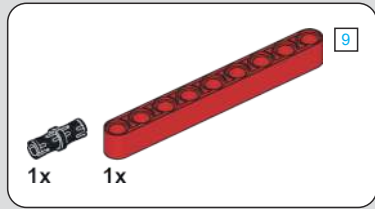
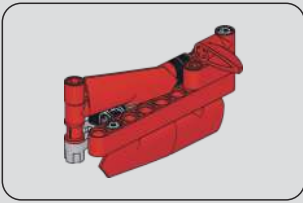

212

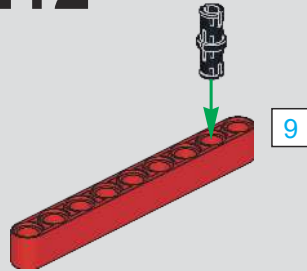

213

1x ↑ (光滑栓)  
(Technic Pin without Friction)

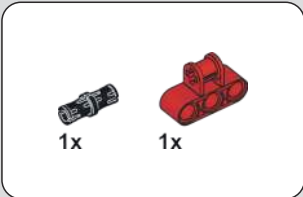
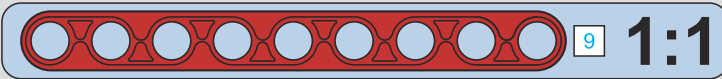
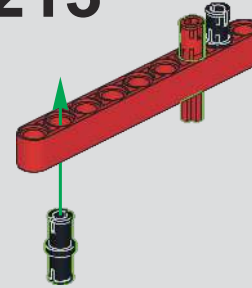

214

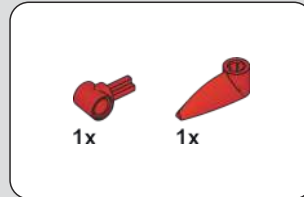
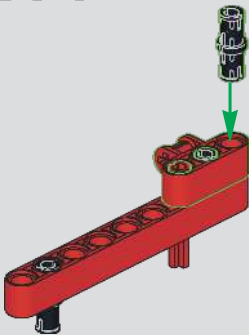

215

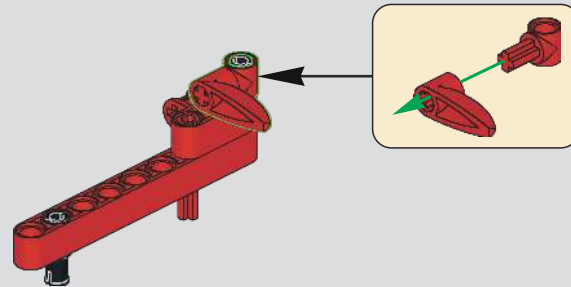

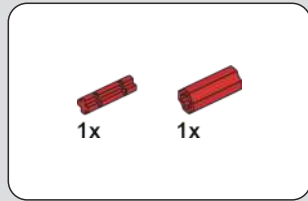

216

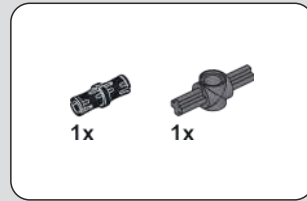
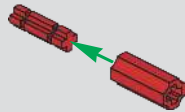

217

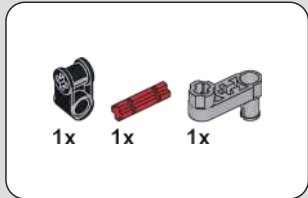
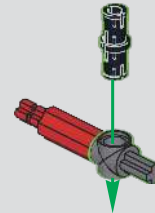

218

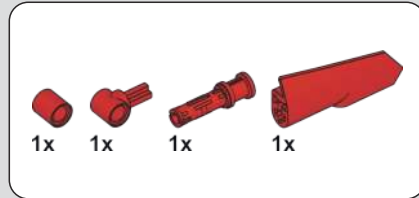
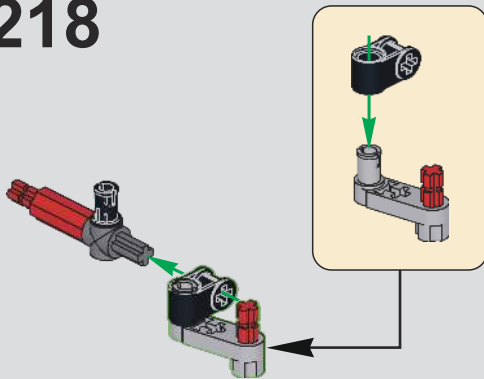

219

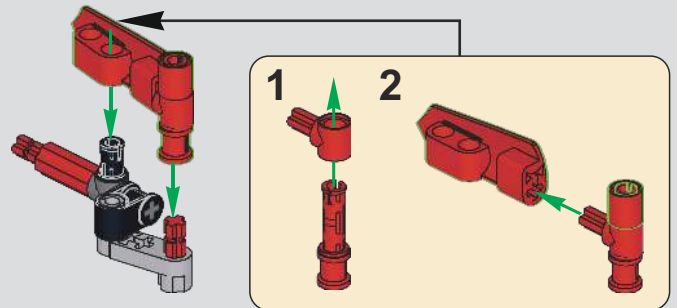

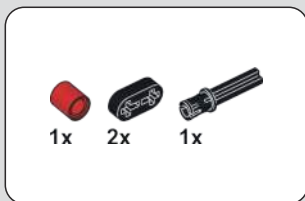

## 220

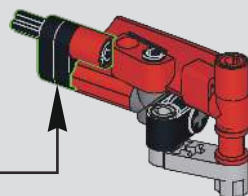
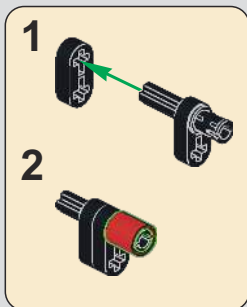

## 221

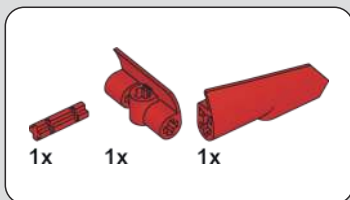
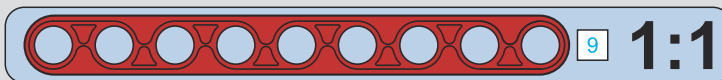
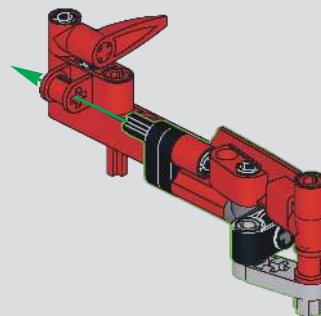

## 222

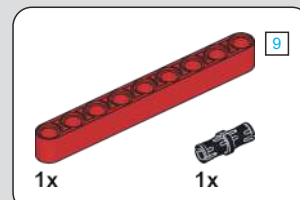
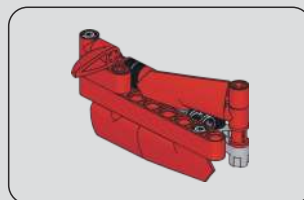
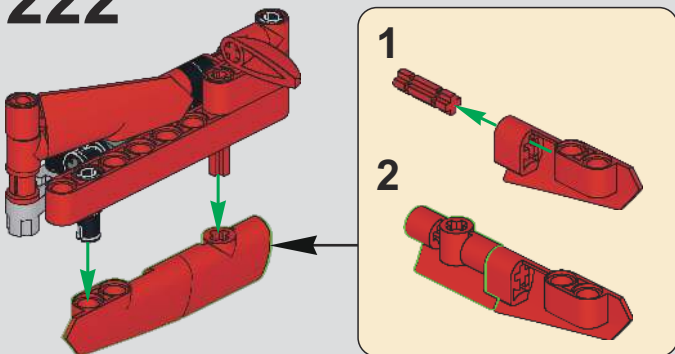

## 223

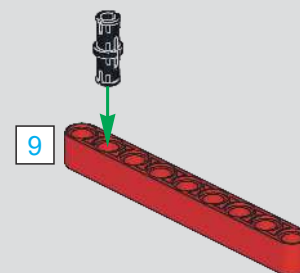



224

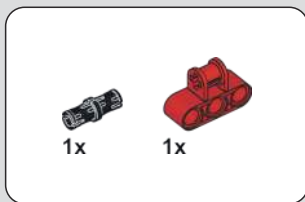
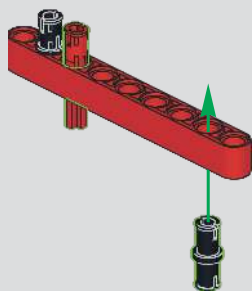

225

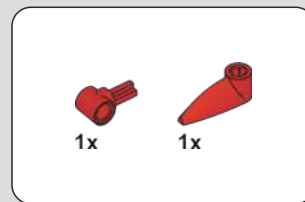
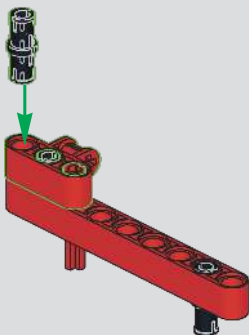

226

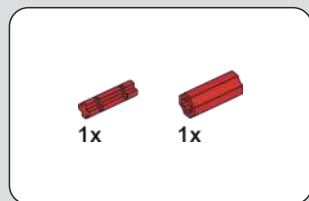
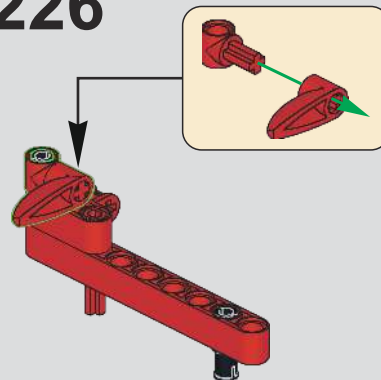

227

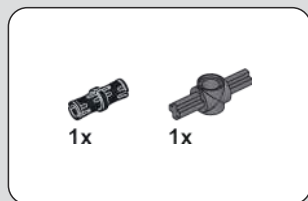
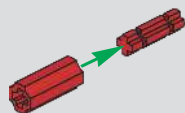

228

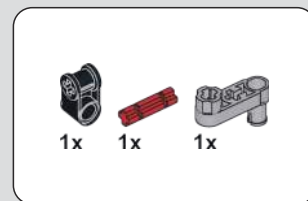
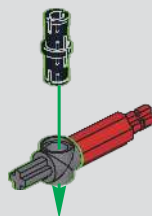

229

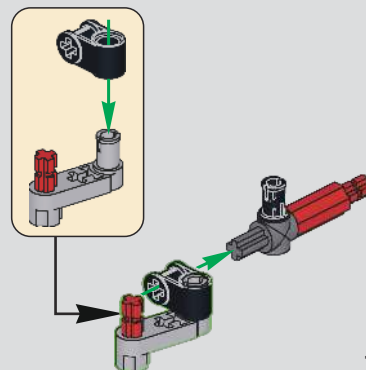

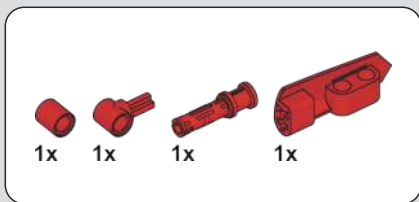

230

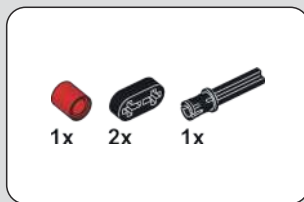
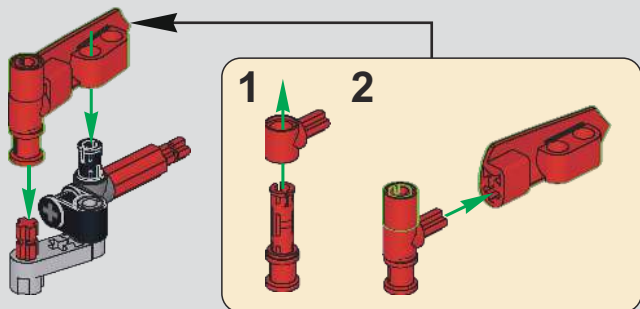

231

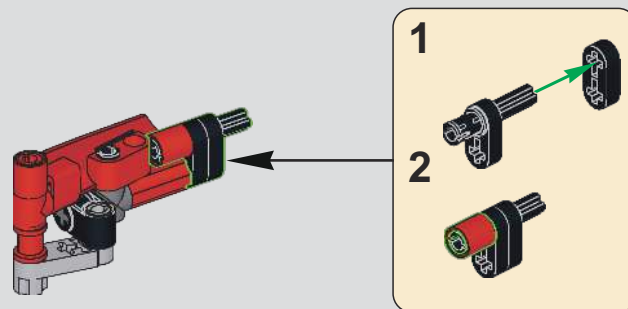

232

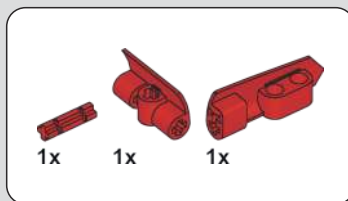
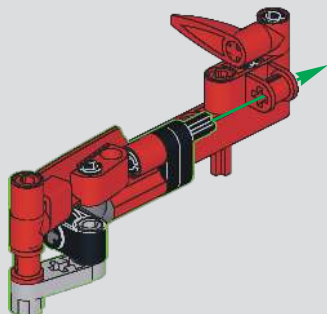

233

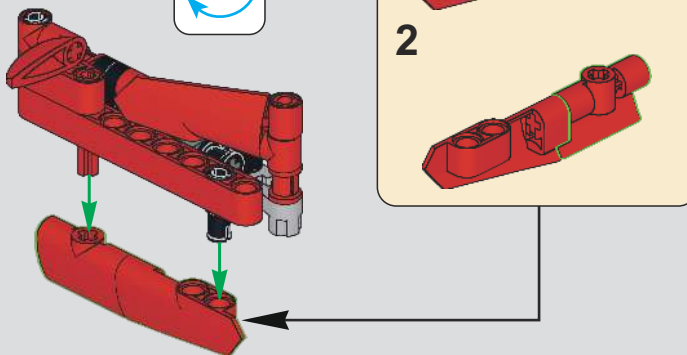

234

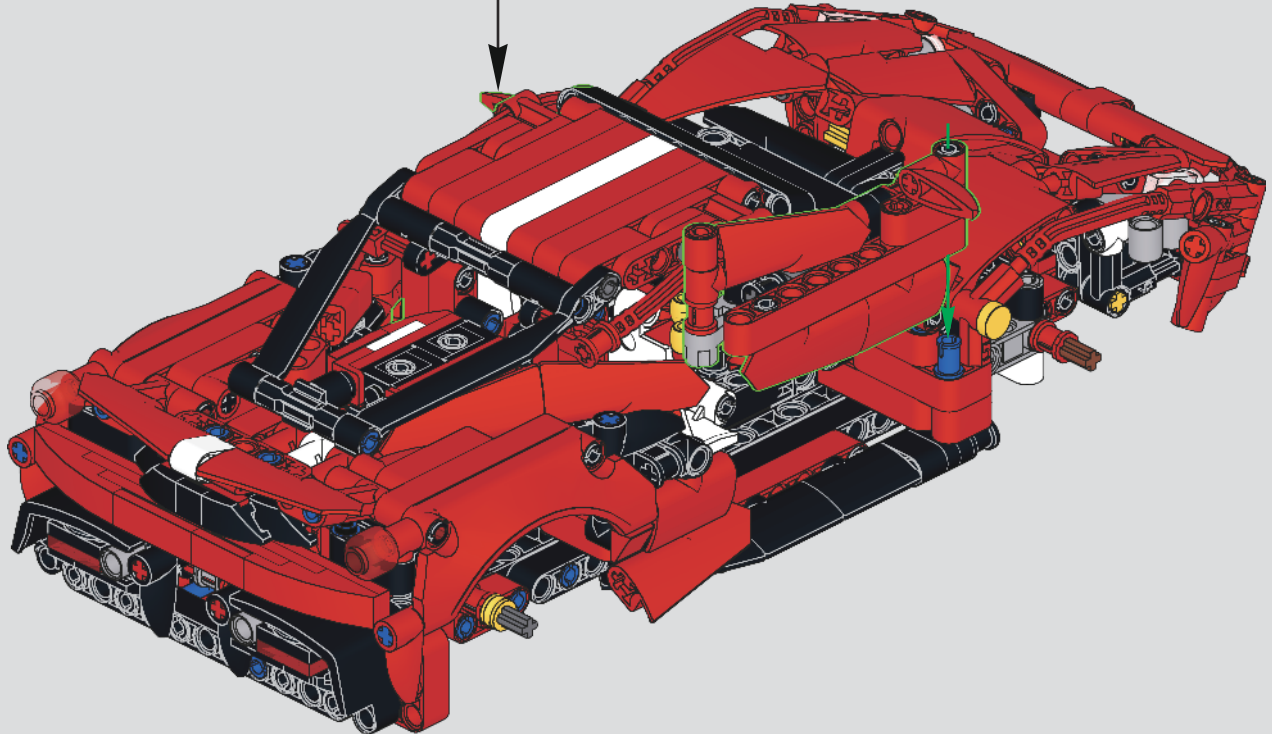
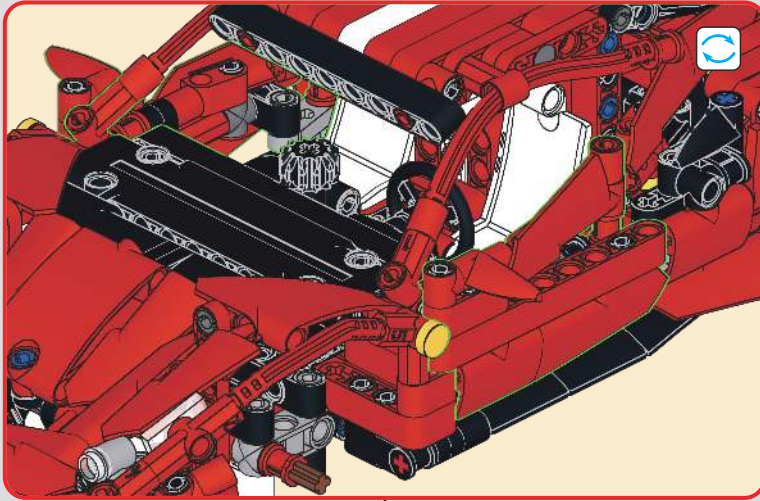

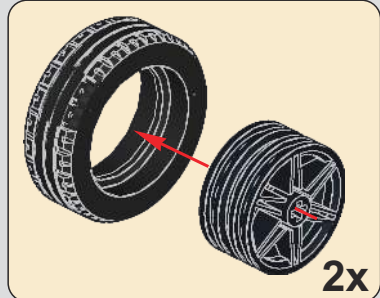
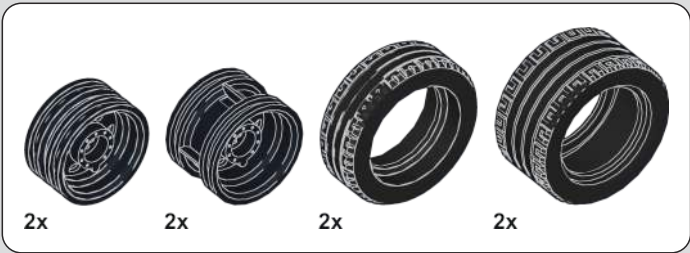

# 235

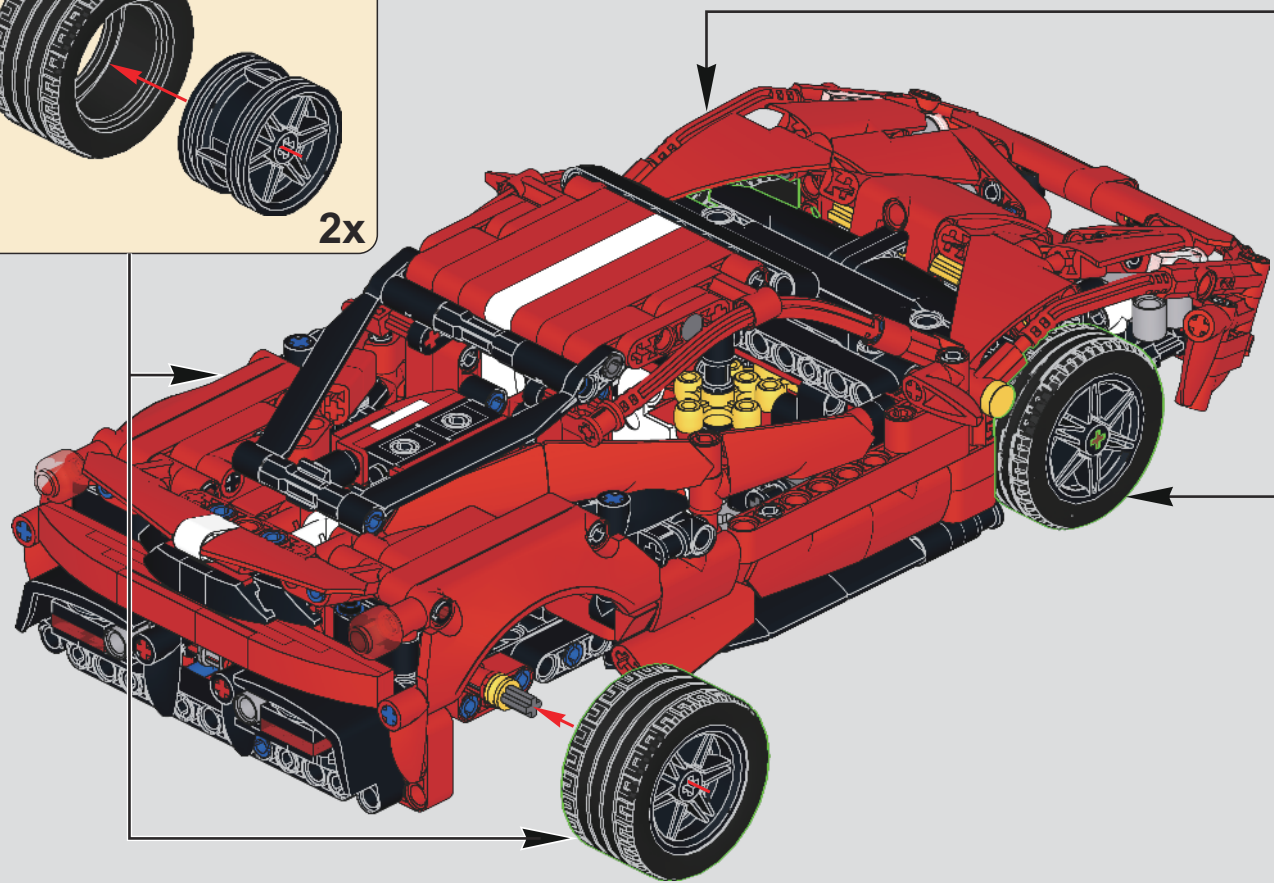
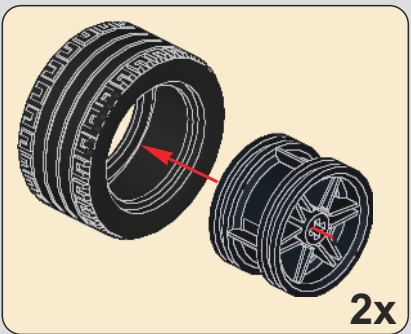

236

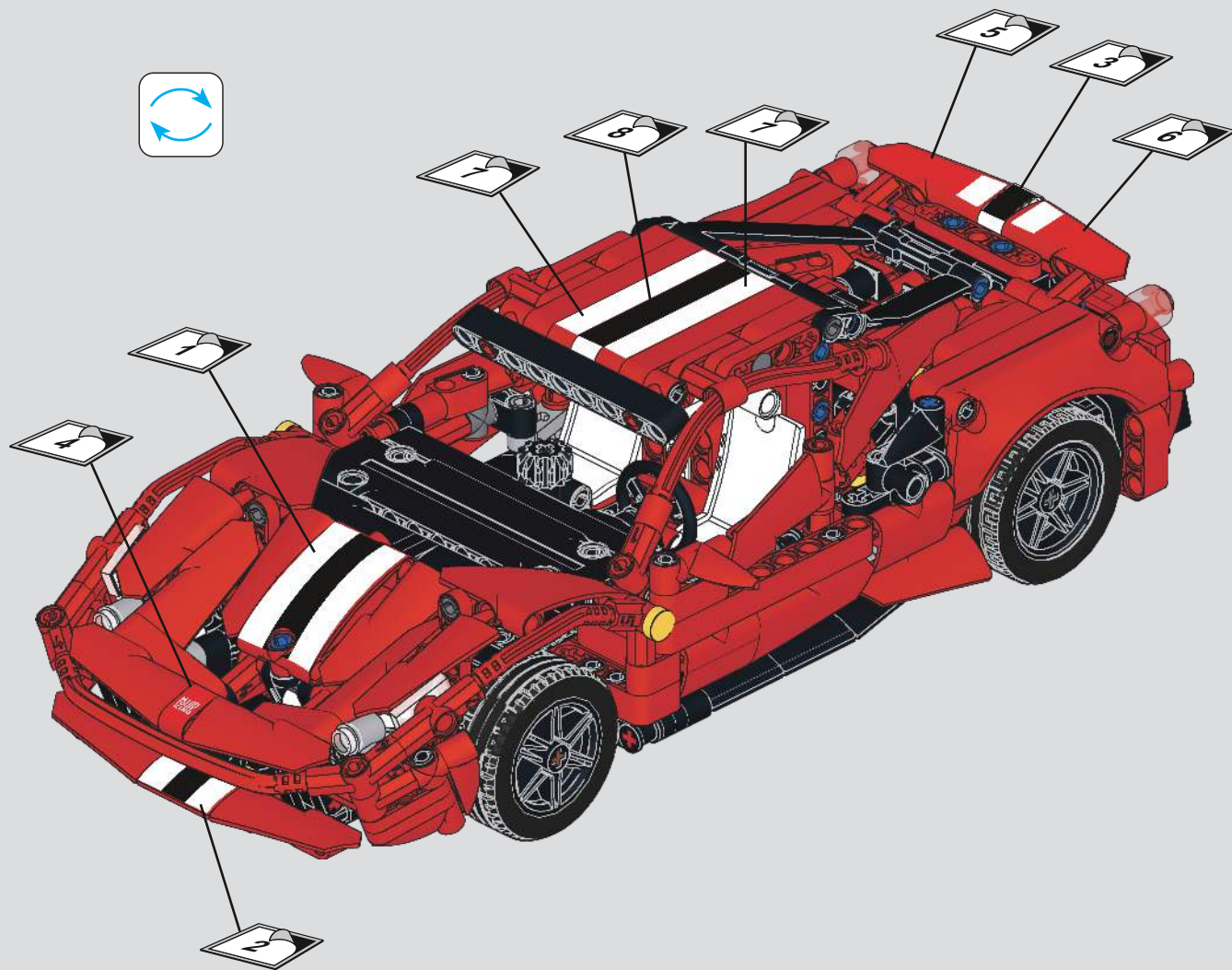

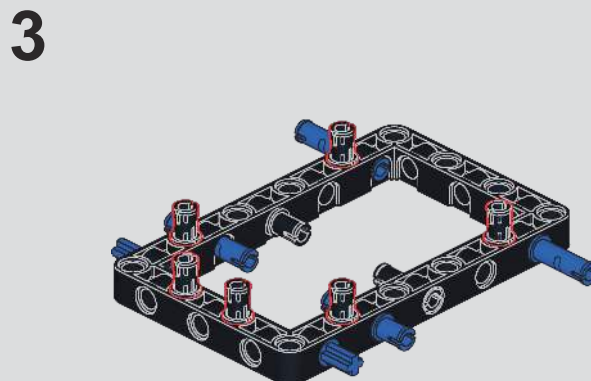
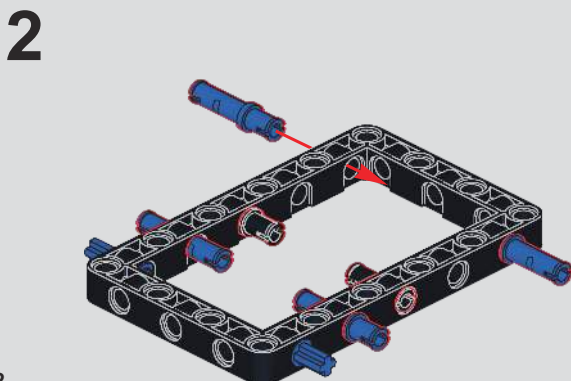
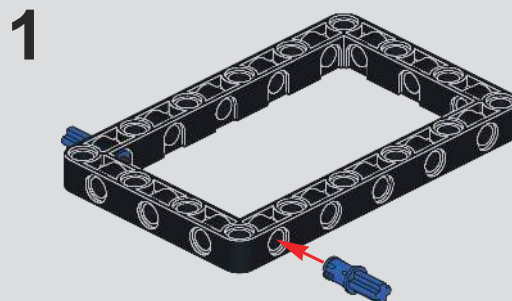
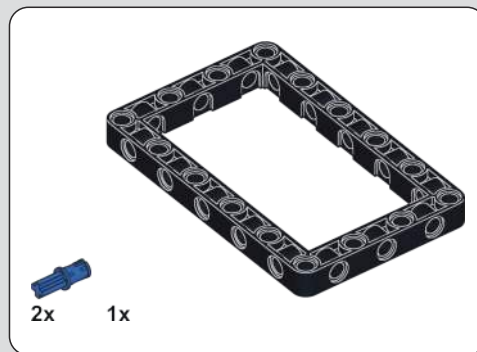
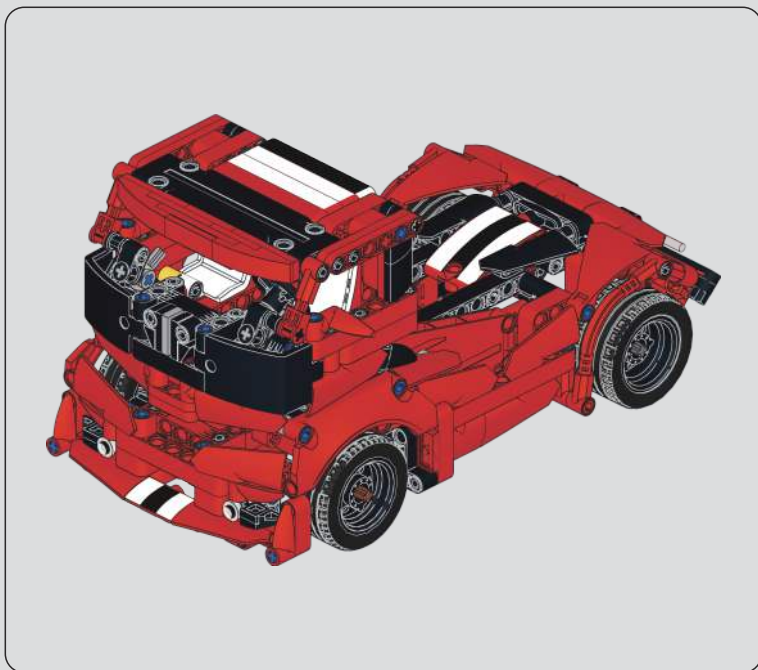

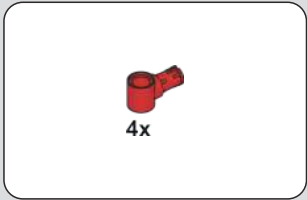

4

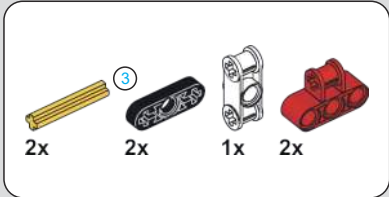
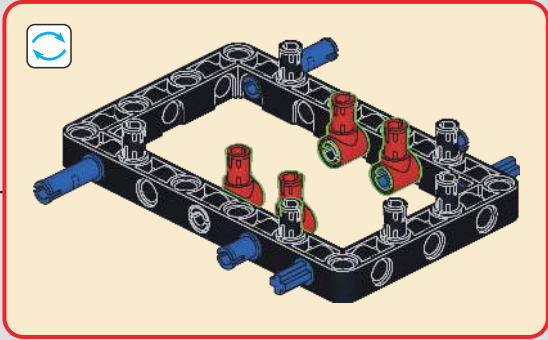
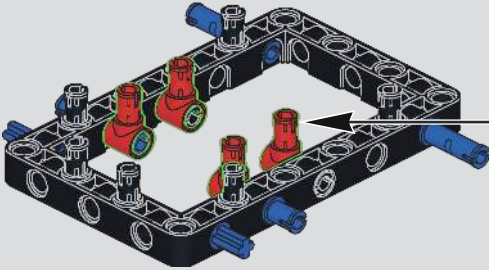

5

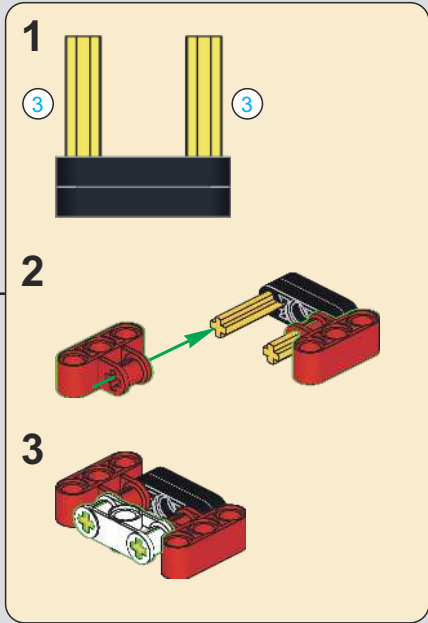
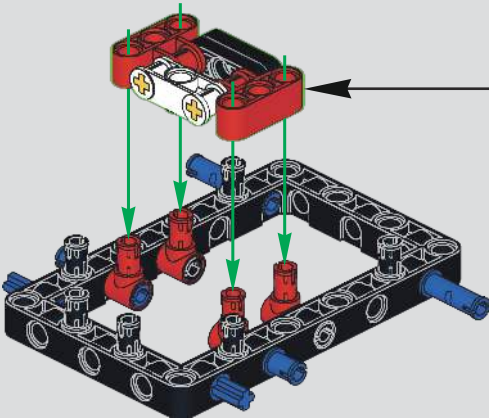

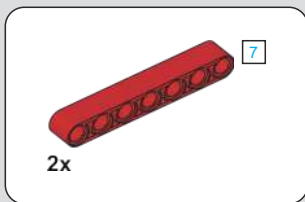

6

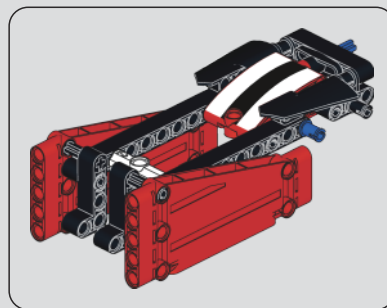

7

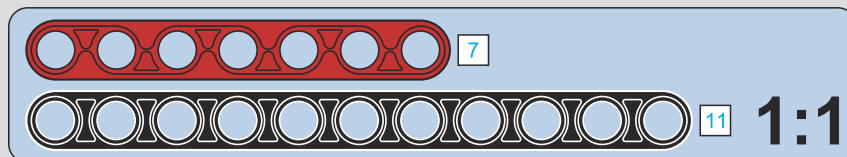
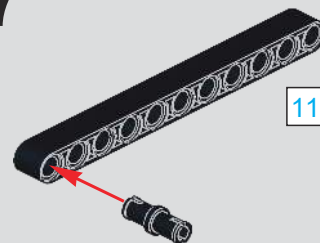
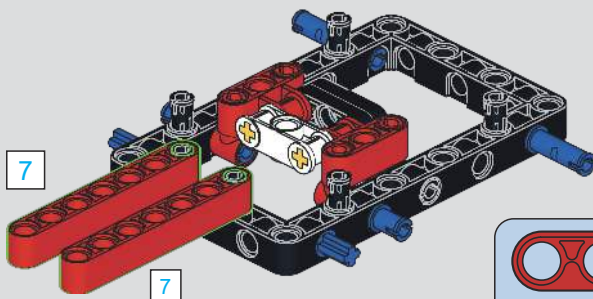

8

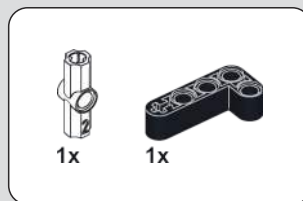

9

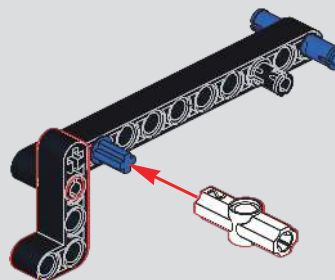
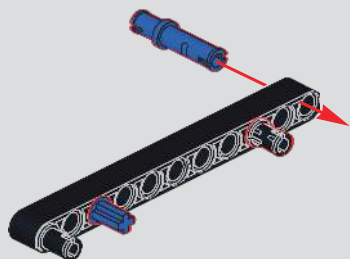

(Technic Pin without Friction)  
(光滑栓)

2x 1x

# 10

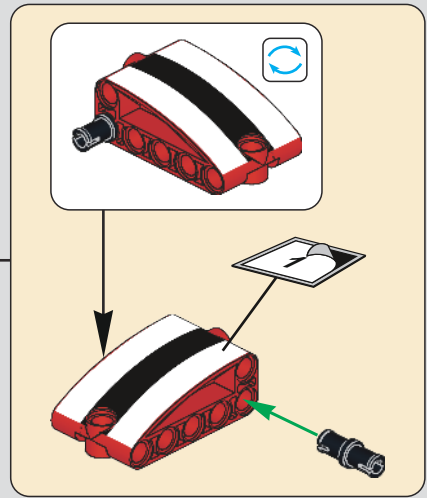
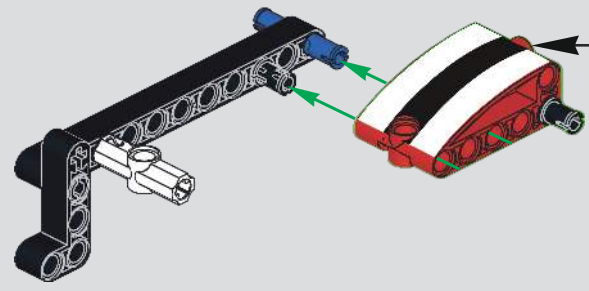

(Technic Pin without Friction)  
(光滑栓)

1x 2x 1x 1x 1x

# 11

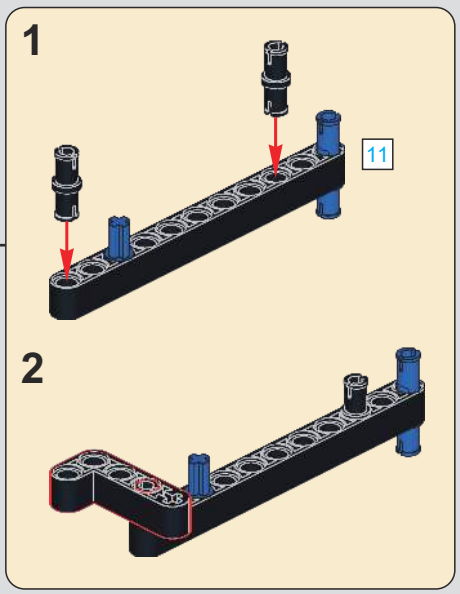
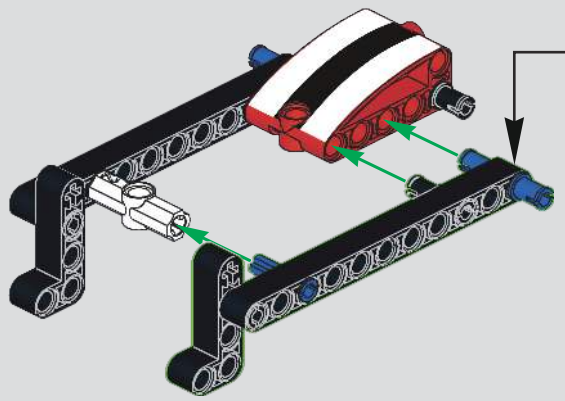

(Technic Pin without Friction)  
(光滑栓)

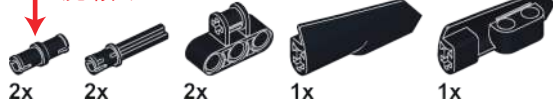

12

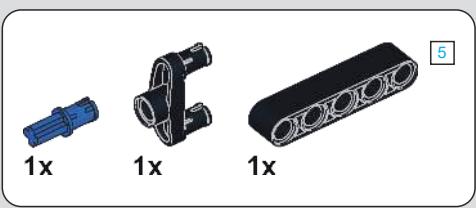
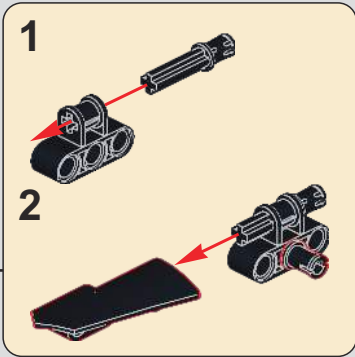
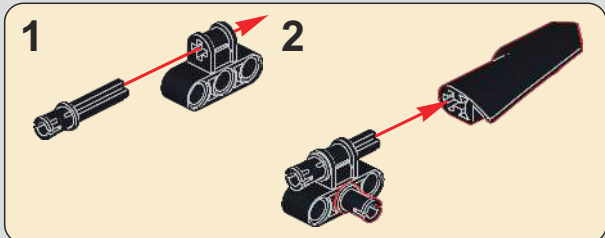
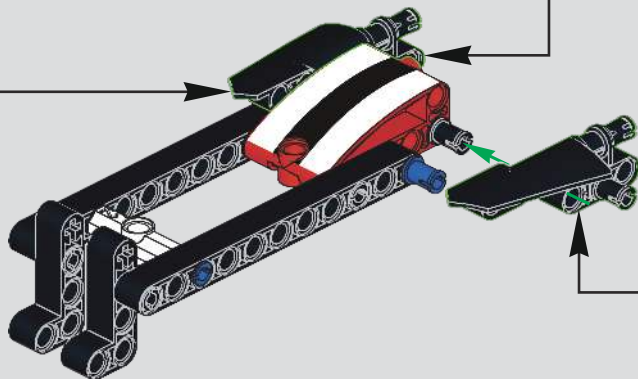
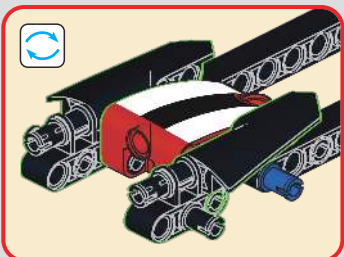

13

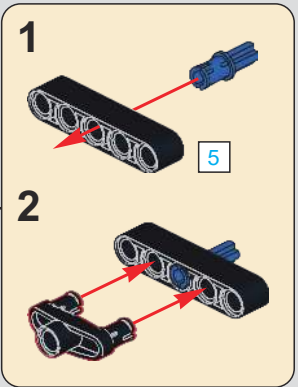
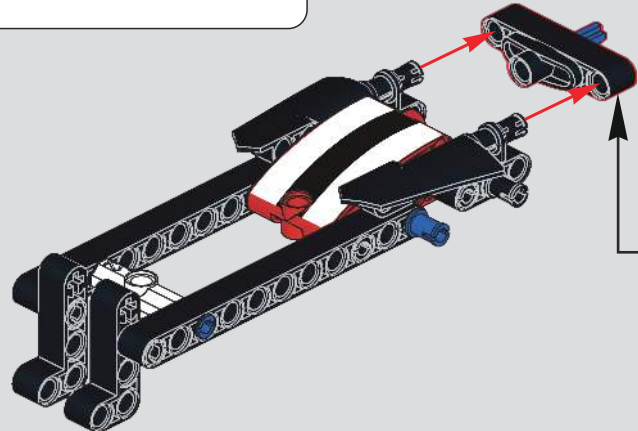

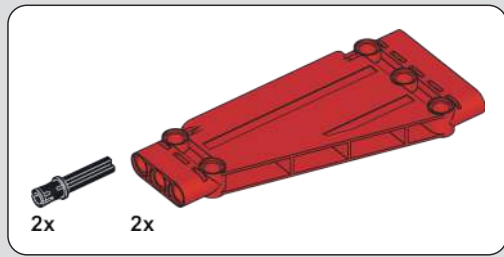

14

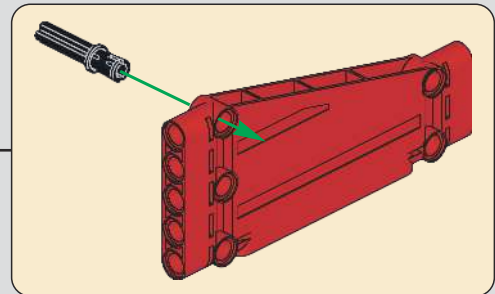
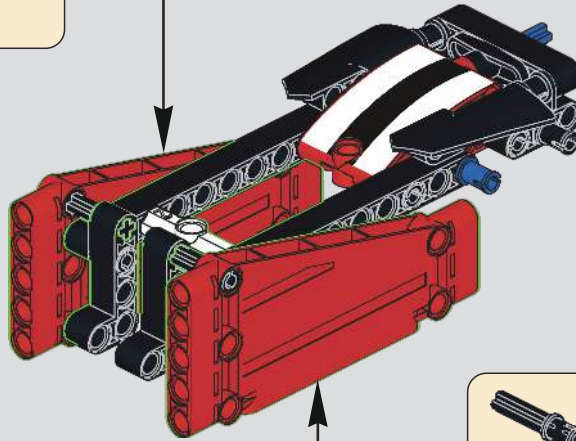
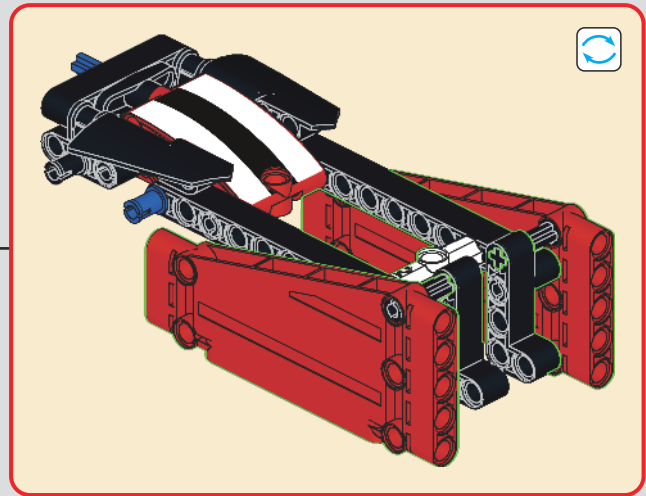
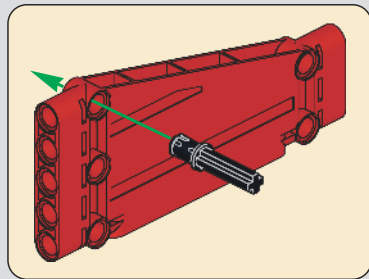

15

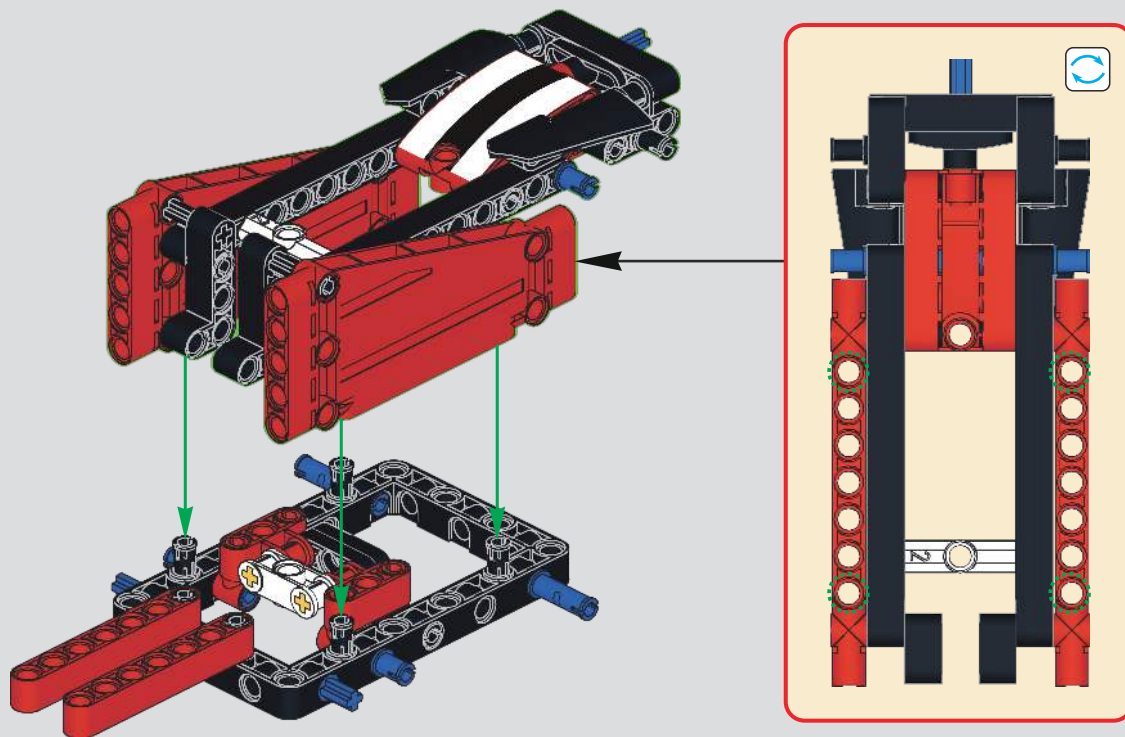

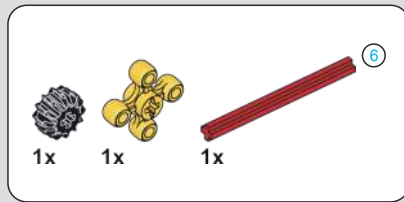

16

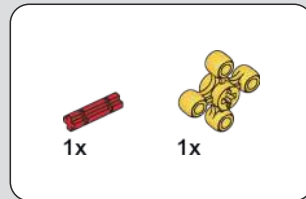
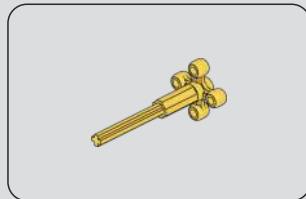
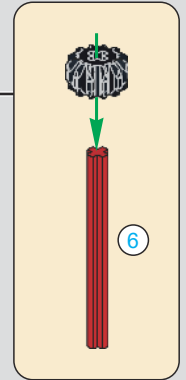
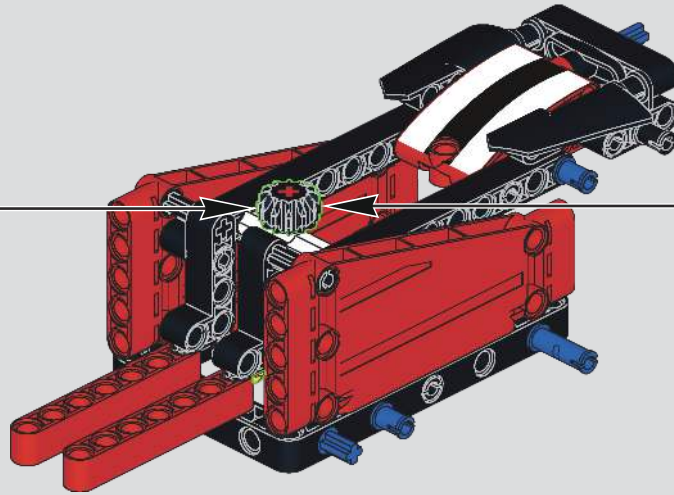
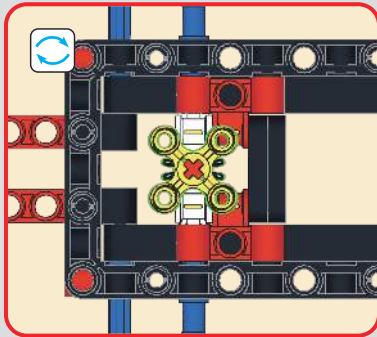

17



18

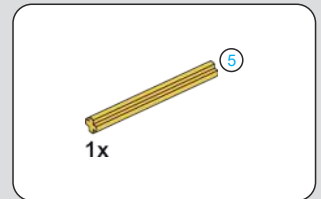

19

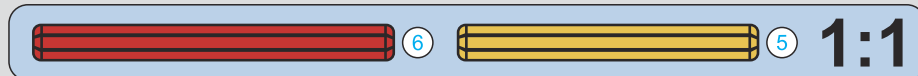
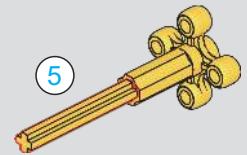
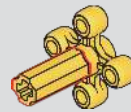
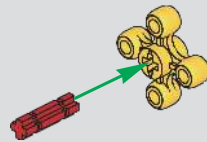

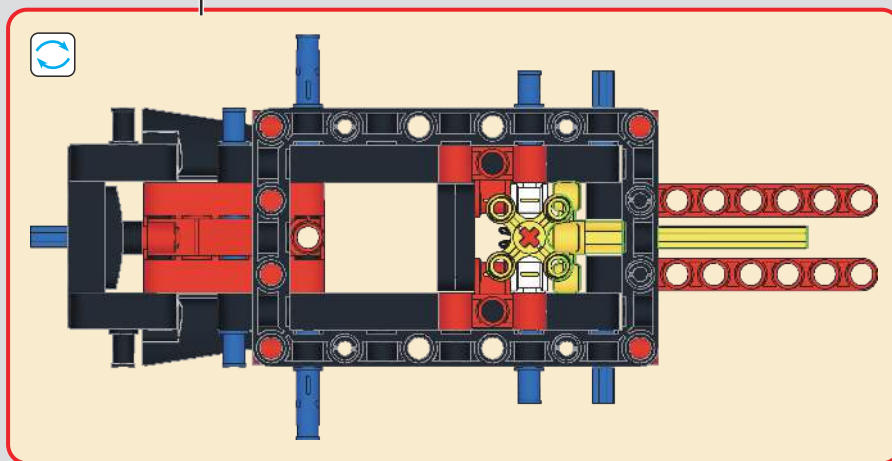
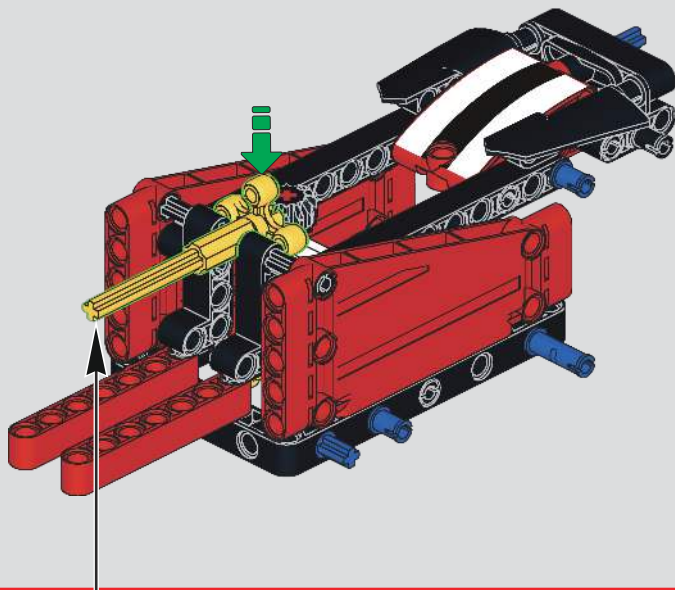

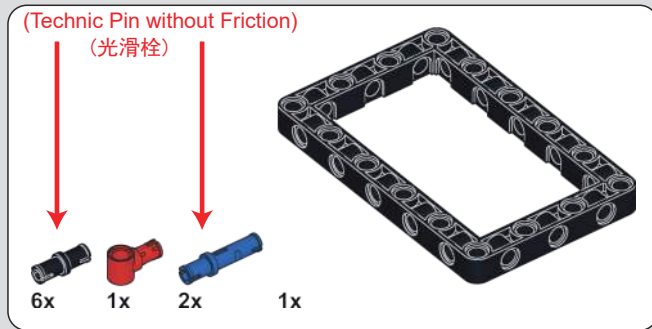

21

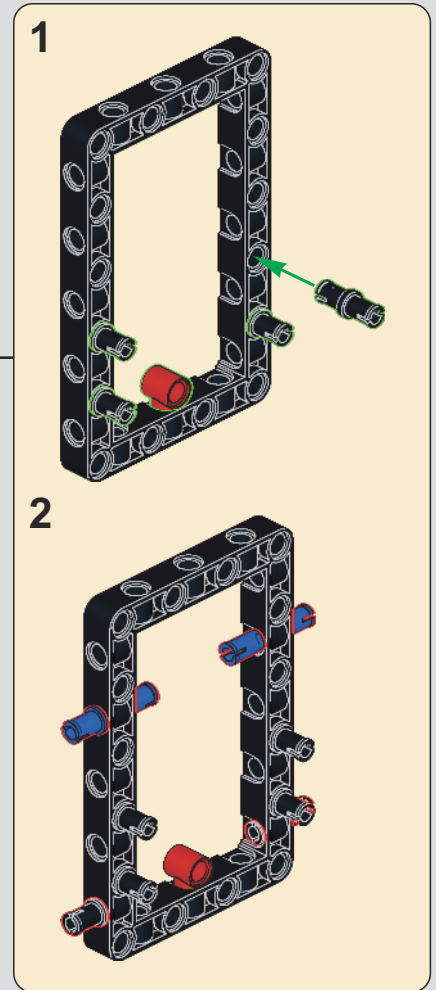
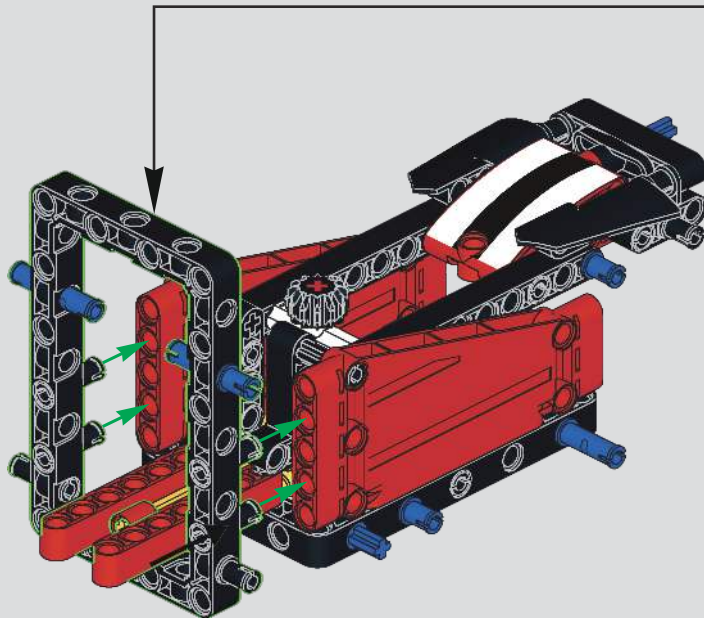

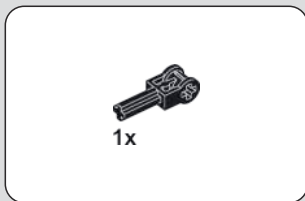

22

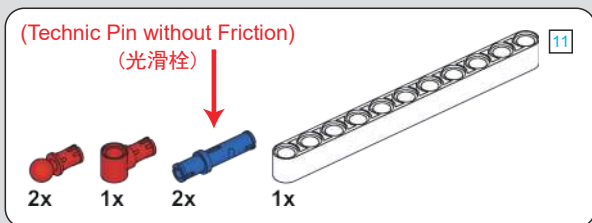
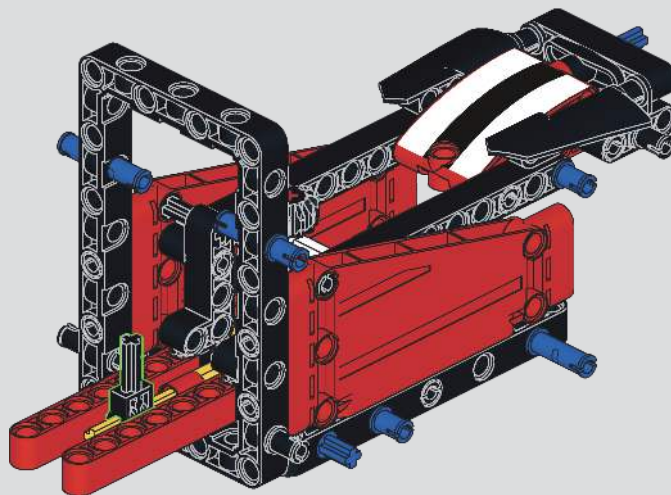

23

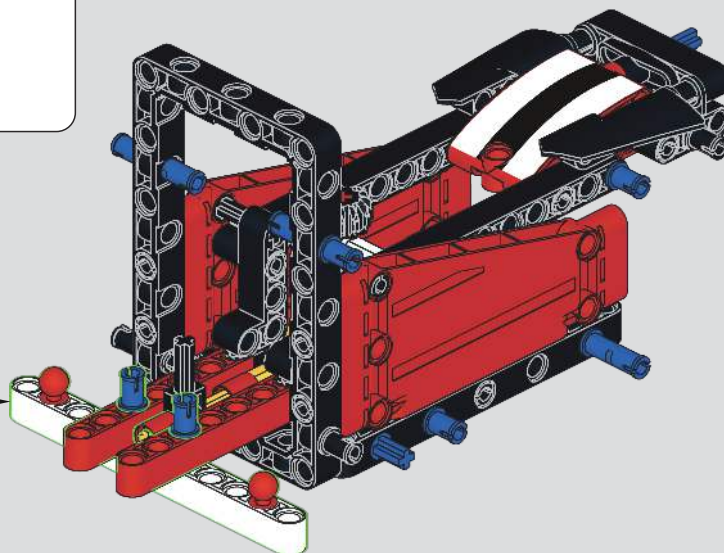
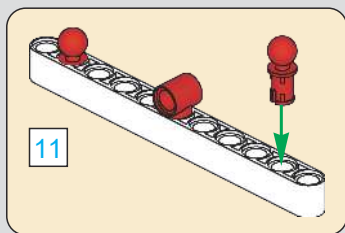

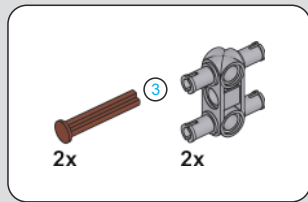

# 24

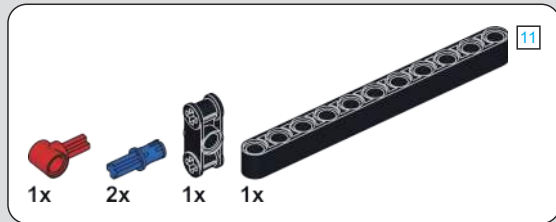
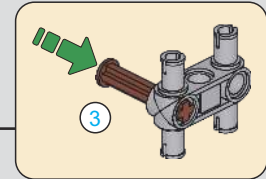
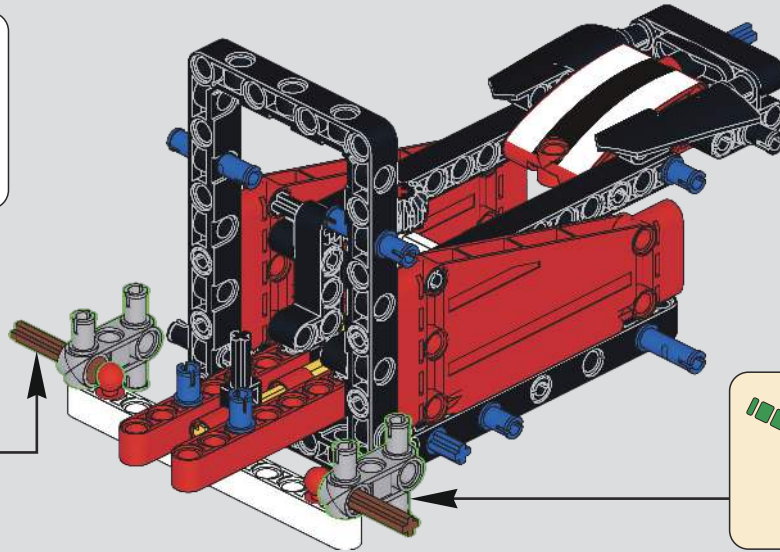
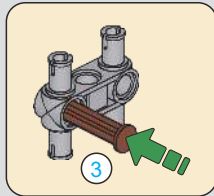

# 25

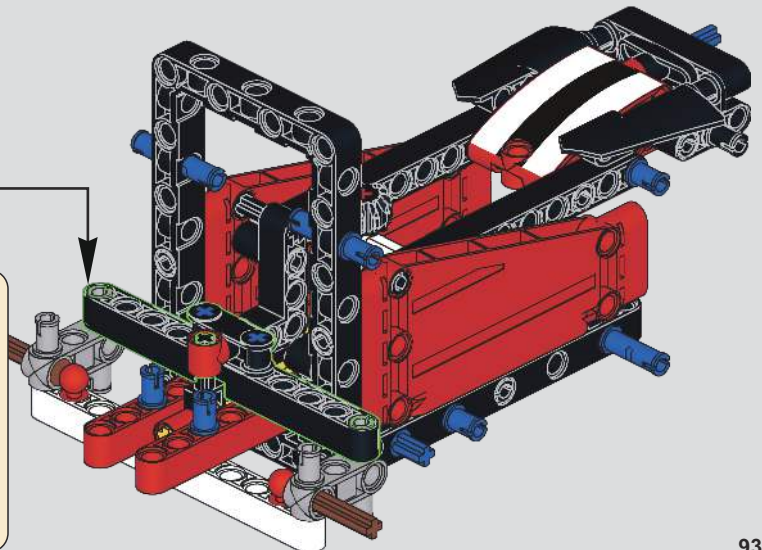
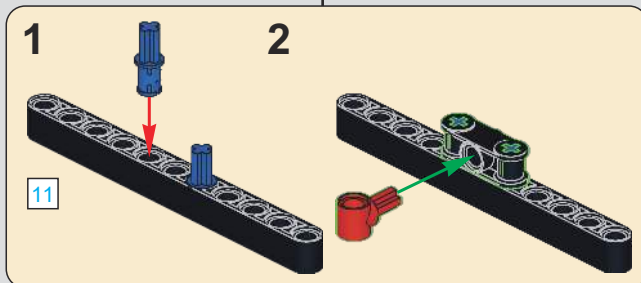

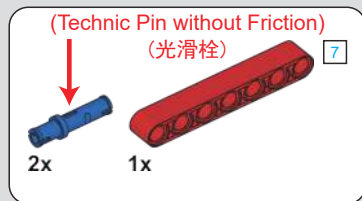
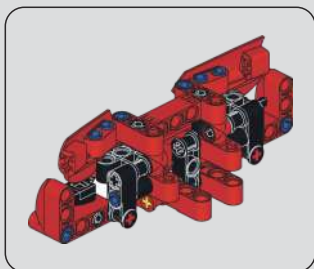

26

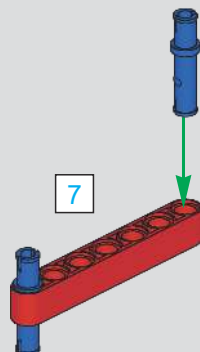

27

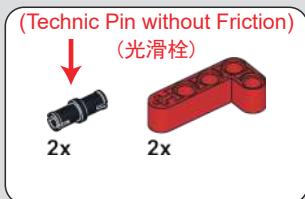
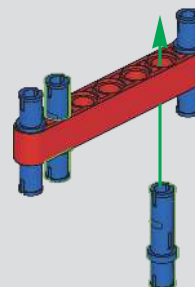

28

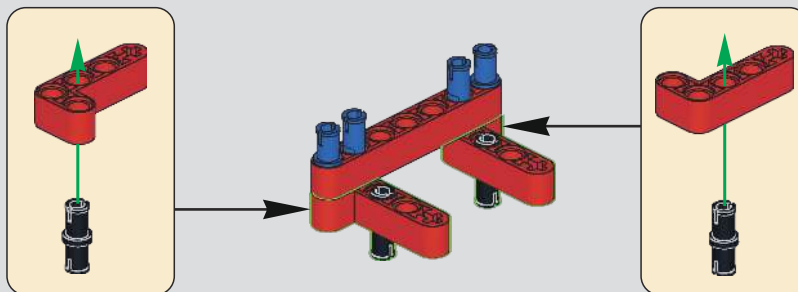
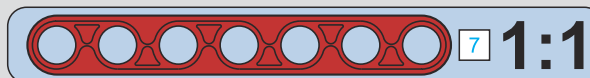



29

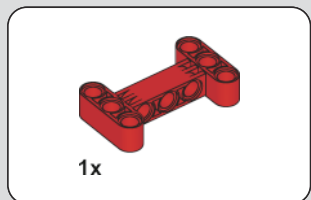
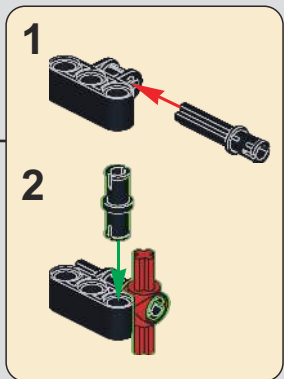
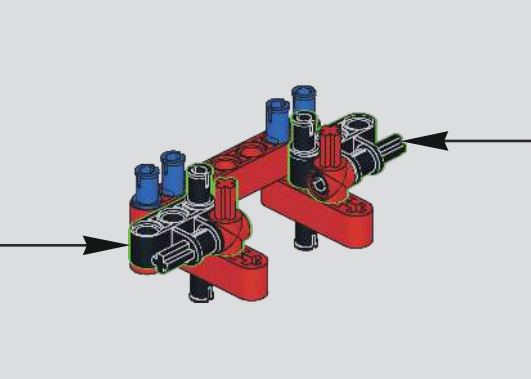
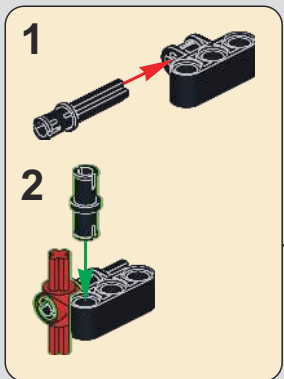

30

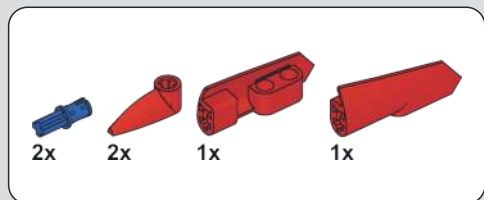
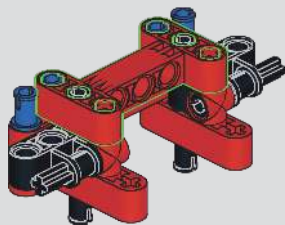

31

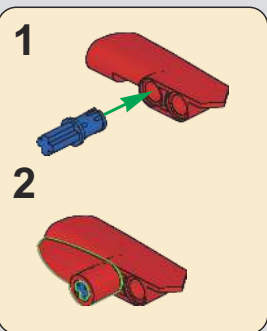
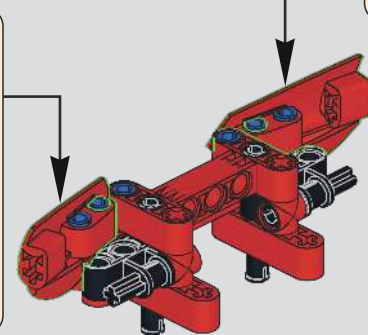
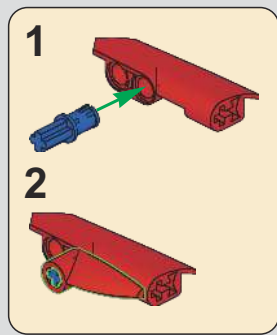

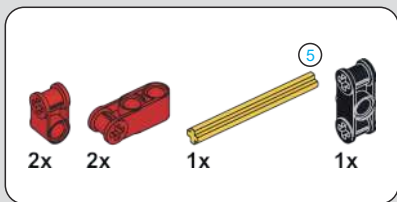

32

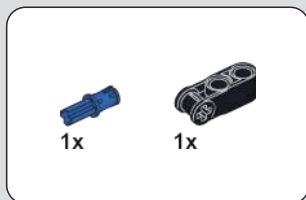
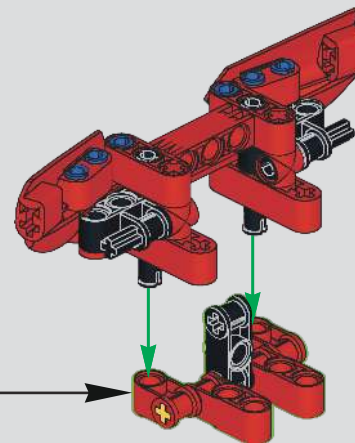
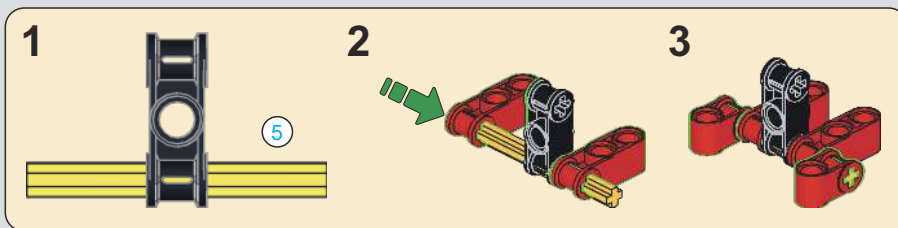

33

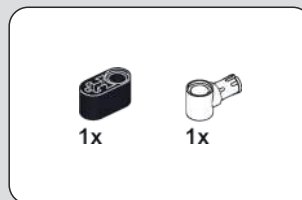
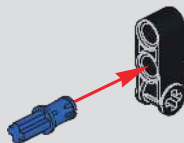

34

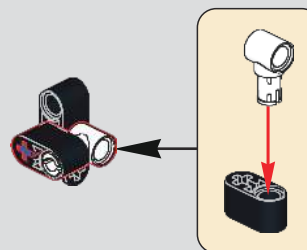

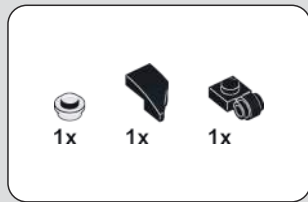

35

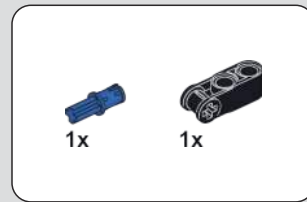
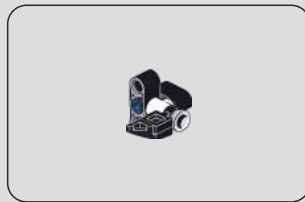

36

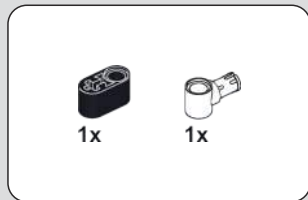
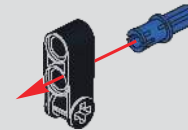
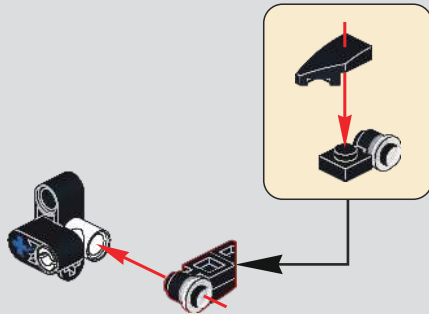

37



38

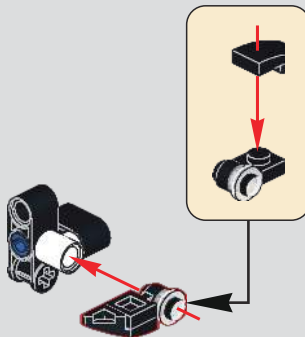
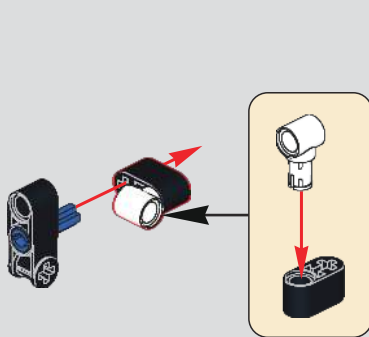

39

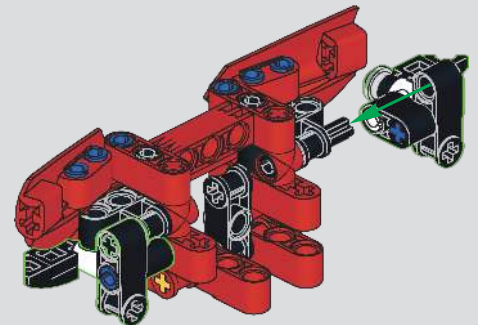

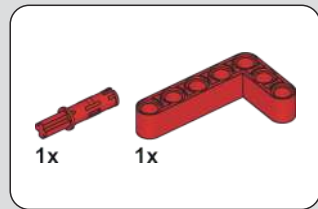
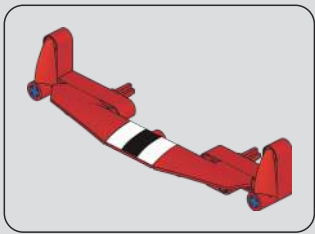

40

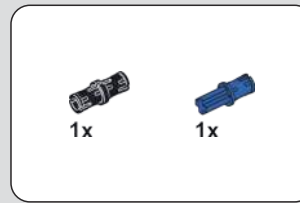

41

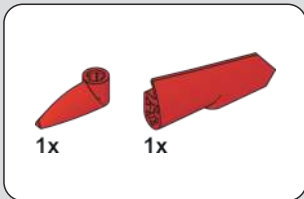
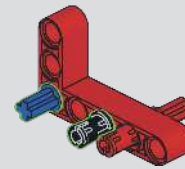
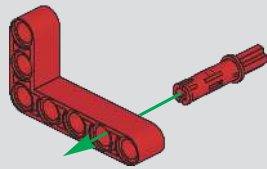

42

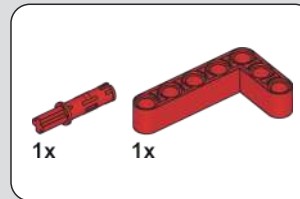
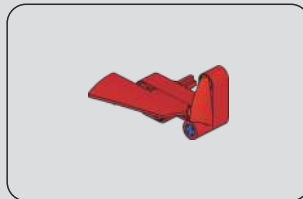

43

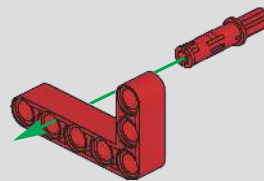
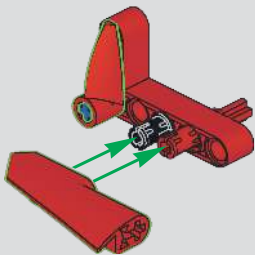



44

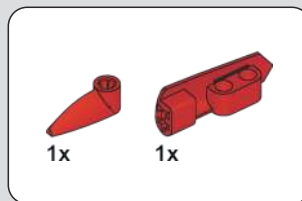
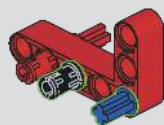

45

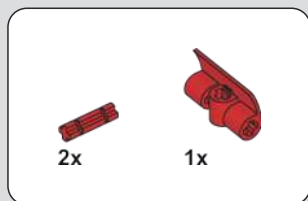
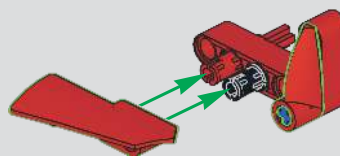

46

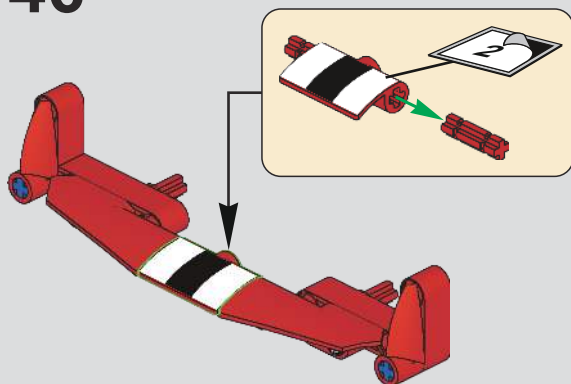

47

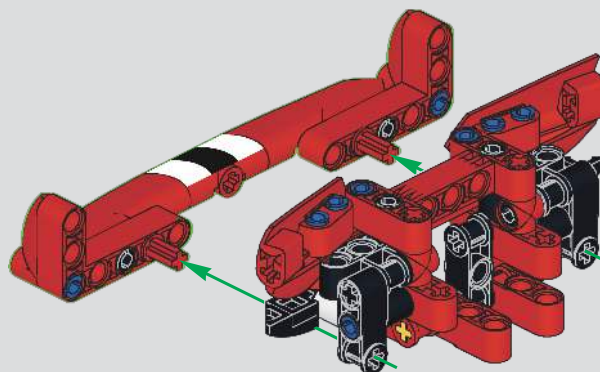



48

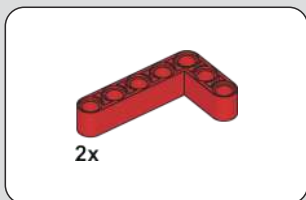
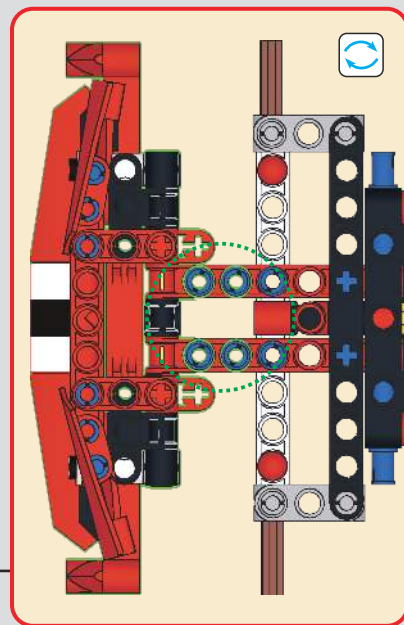
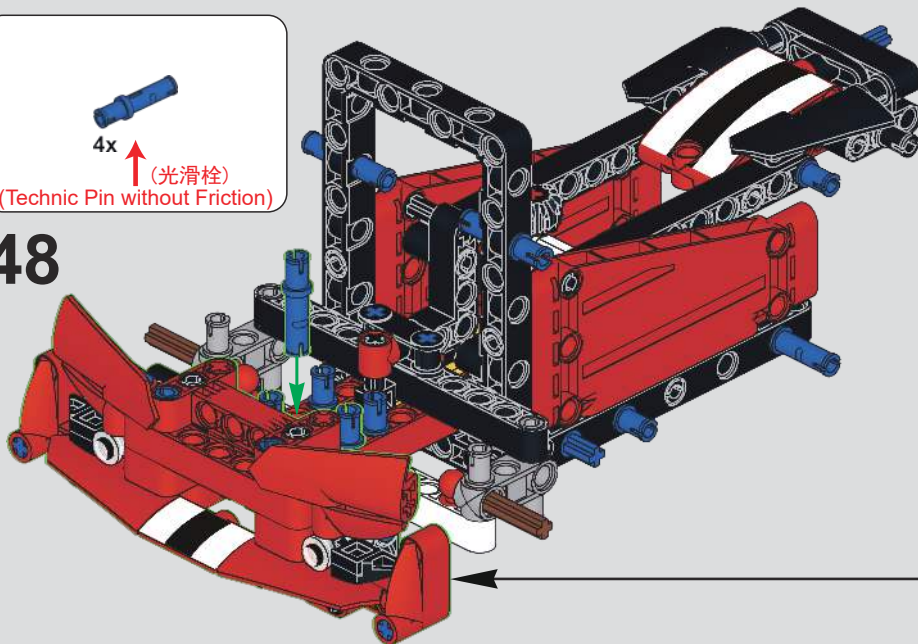

49

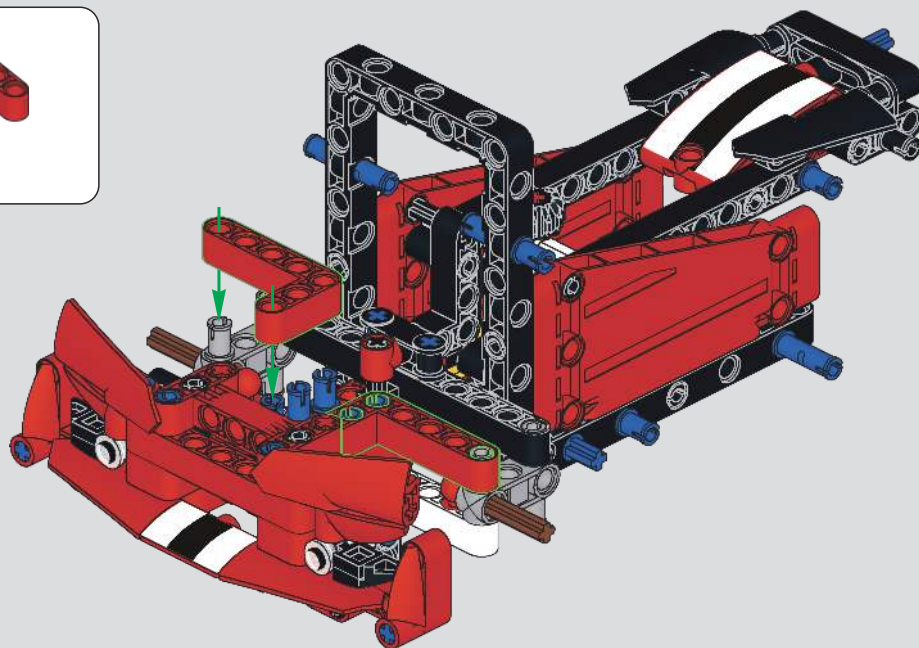

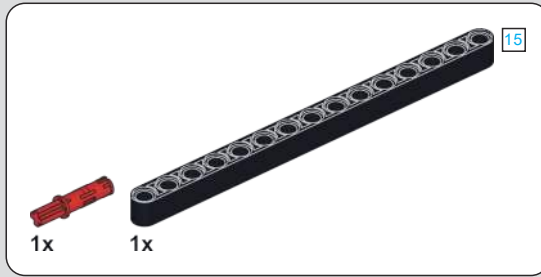
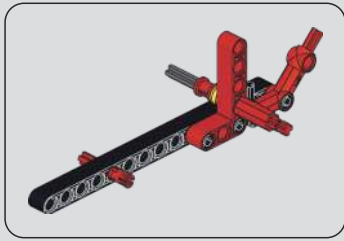

51

50

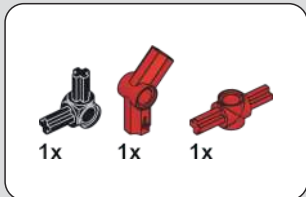
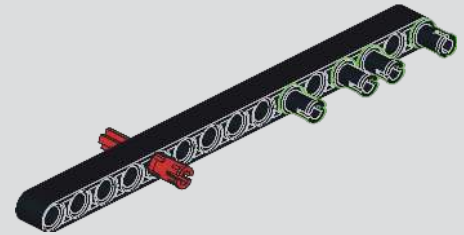
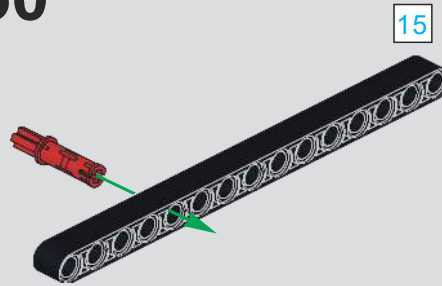

52

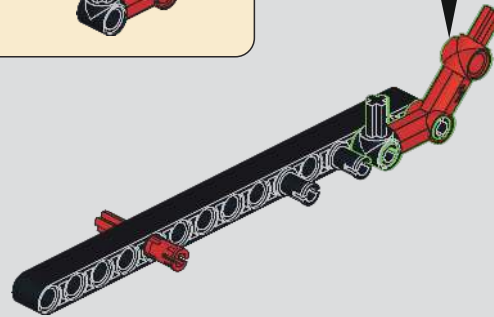
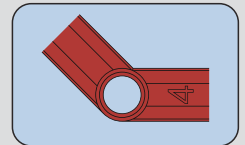
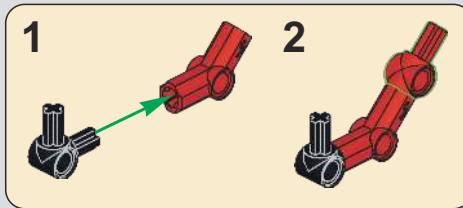

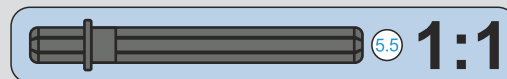
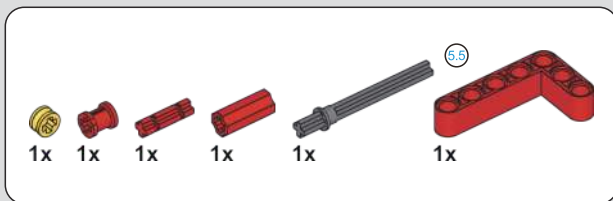

53

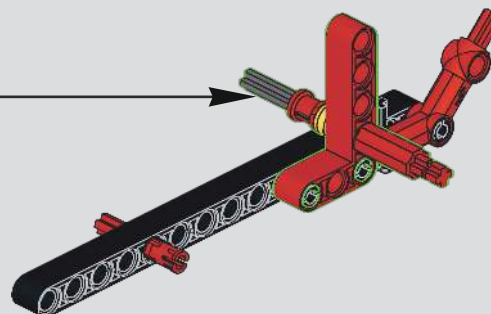
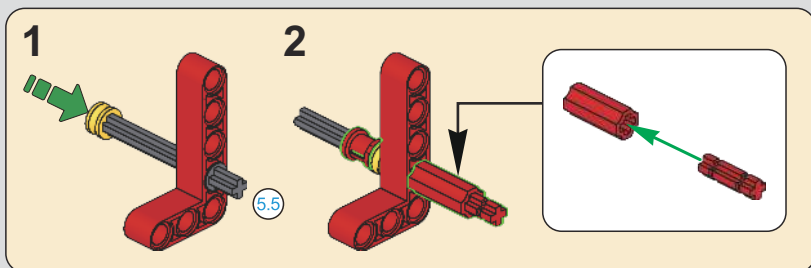

54

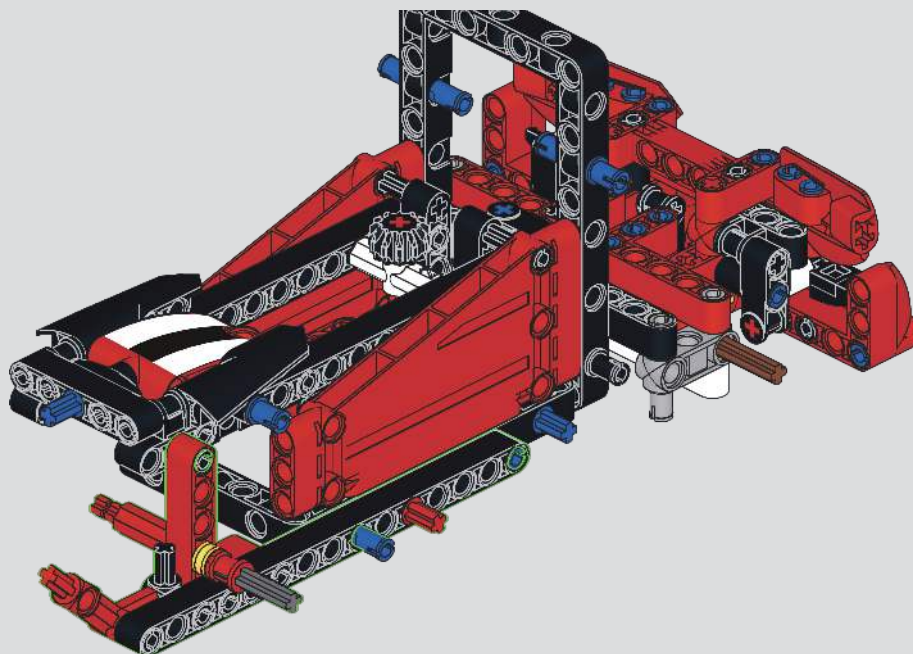

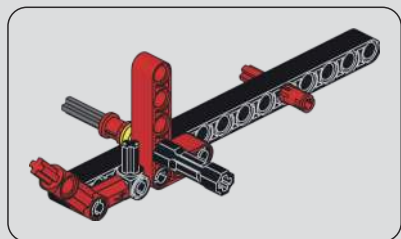

56

55

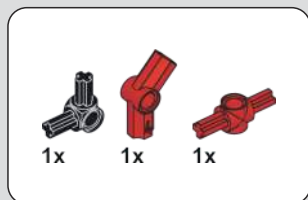
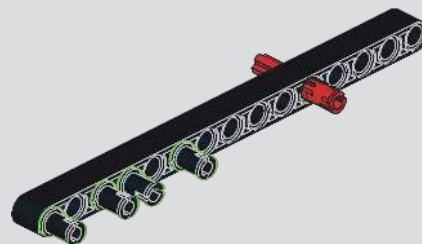
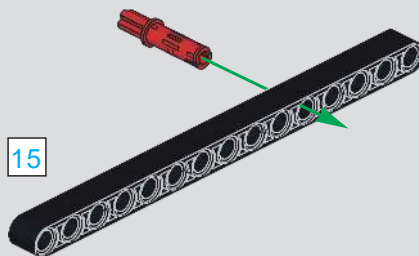

57

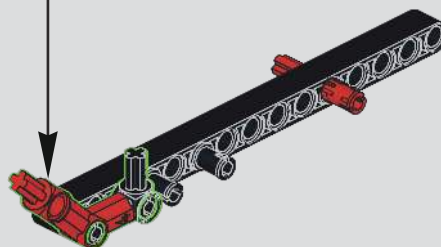
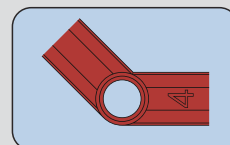
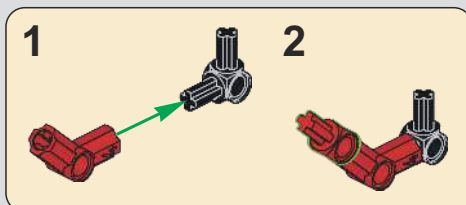

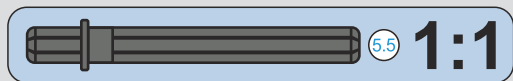
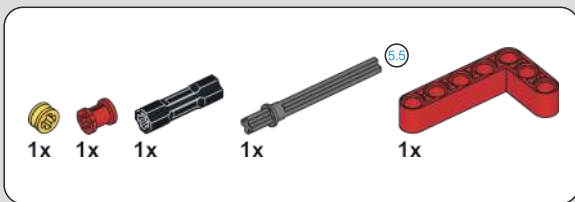

58

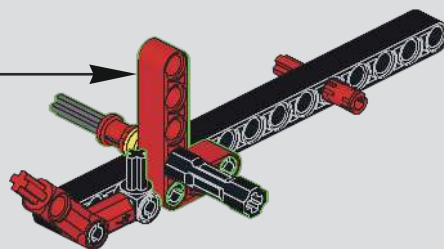
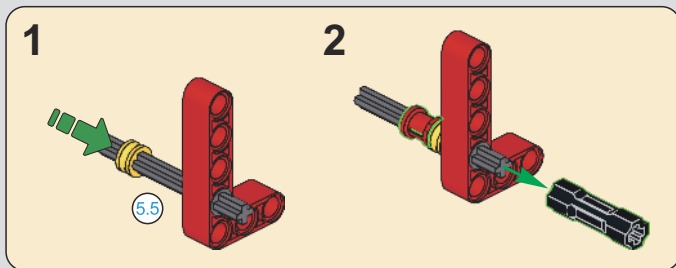

59

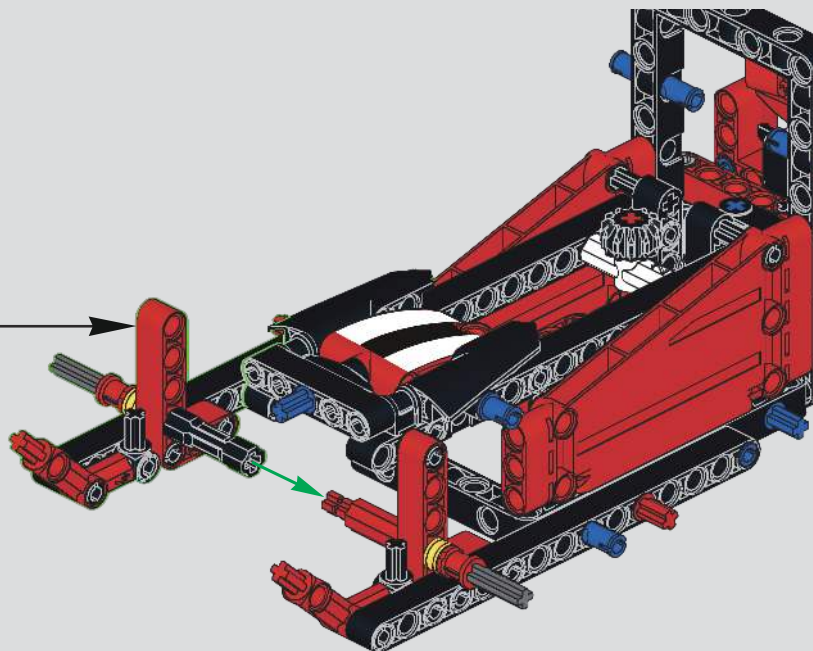
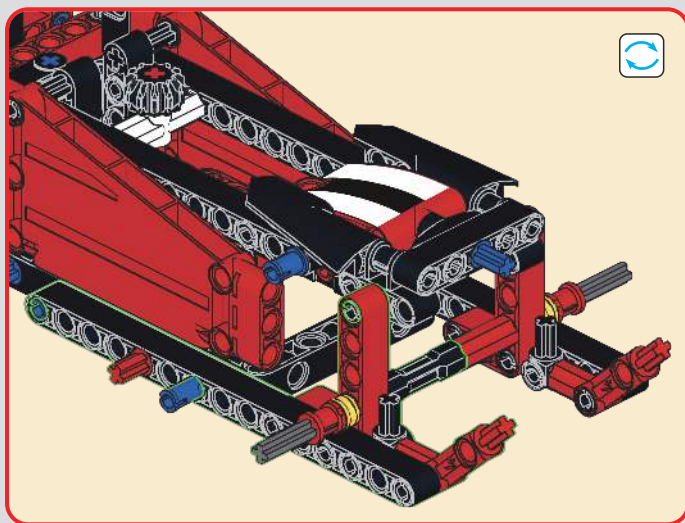

(Technic Pin without Friction)  
(光滑栓)

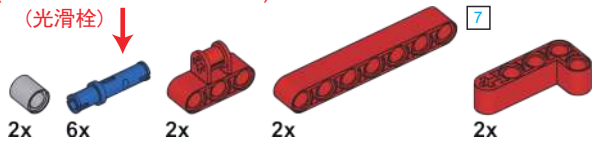

60

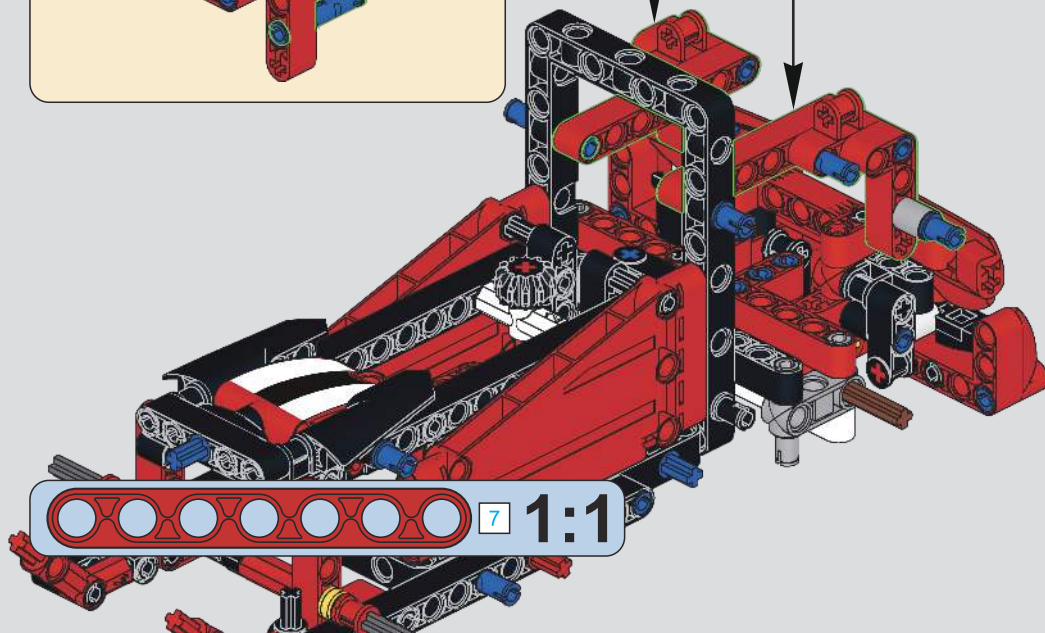
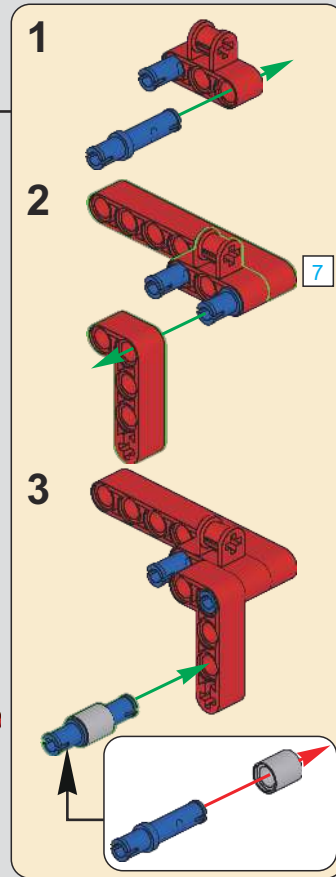
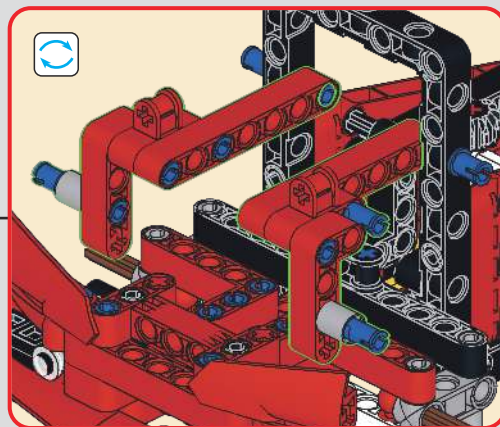
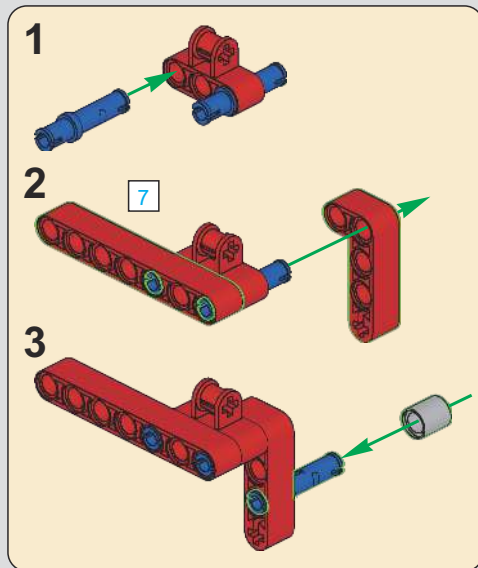

(Technic Pin  
without Friction)  
(光滑栓)



61

1

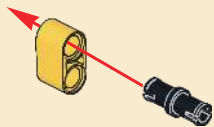

2

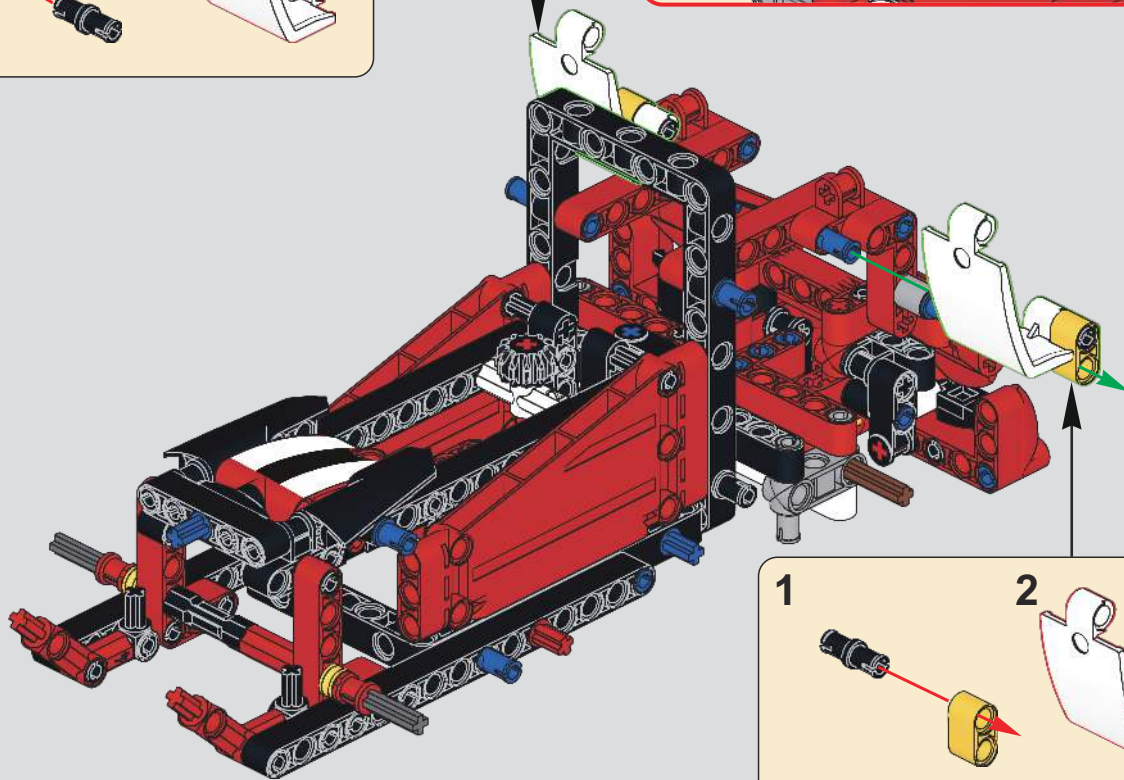
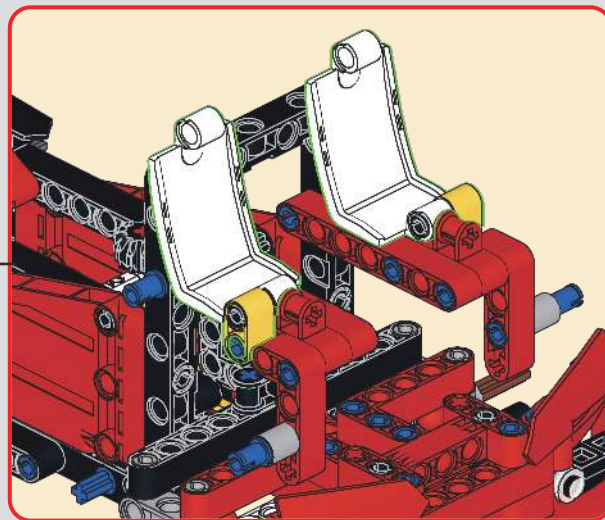
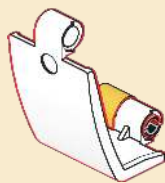

1

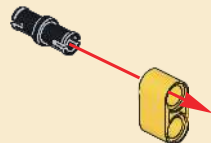

2

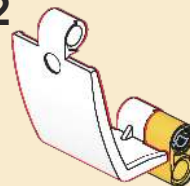

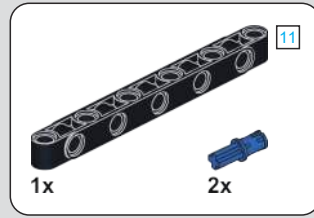
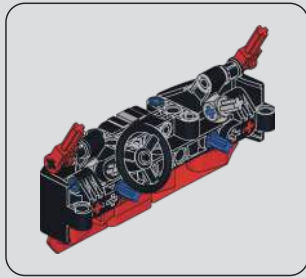

62

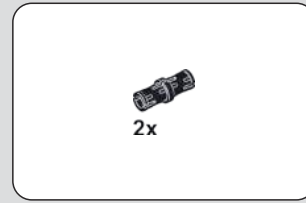
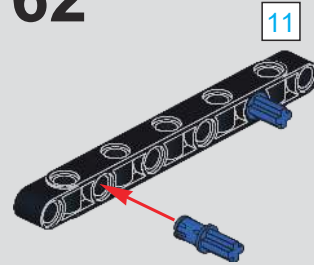

63

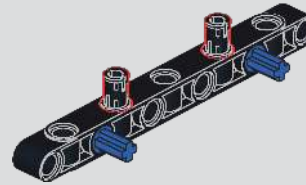

64

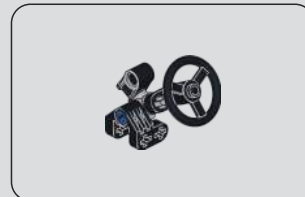
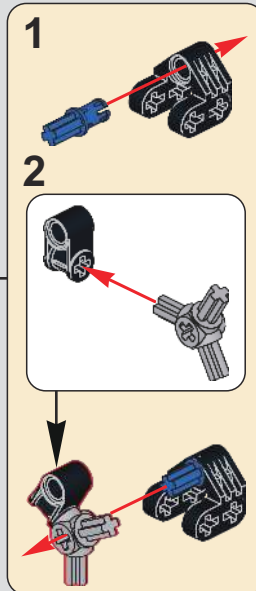
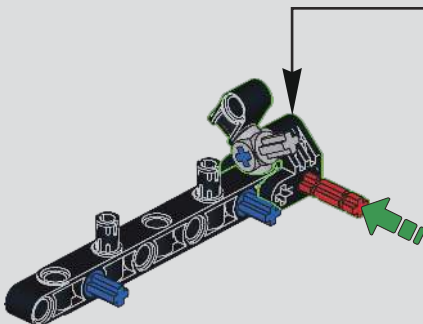

65

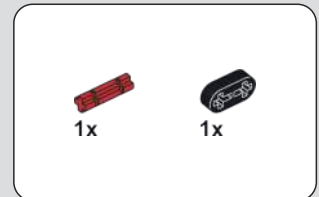



66

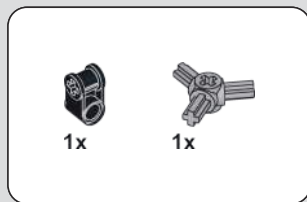
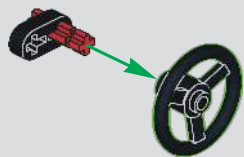

67

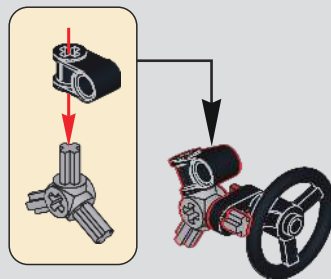

68

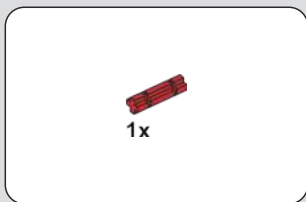
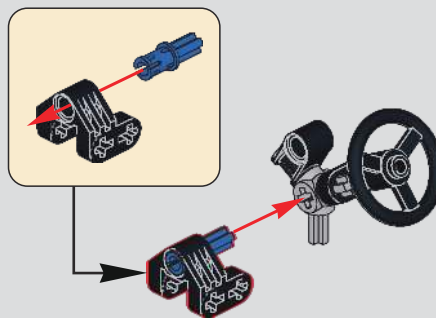

69

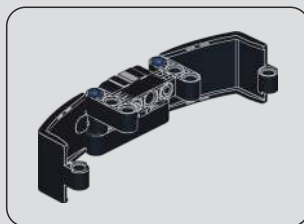
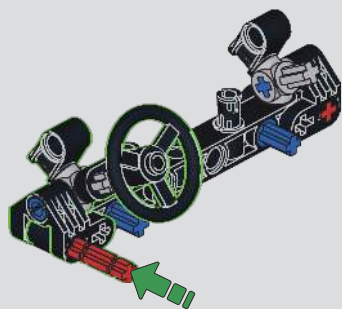

70

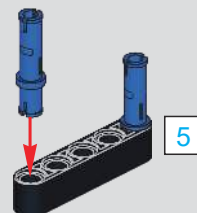



71

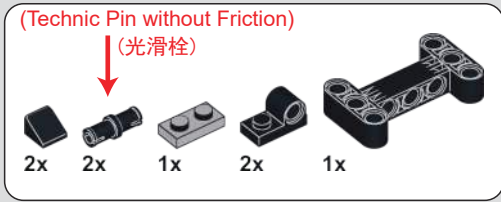
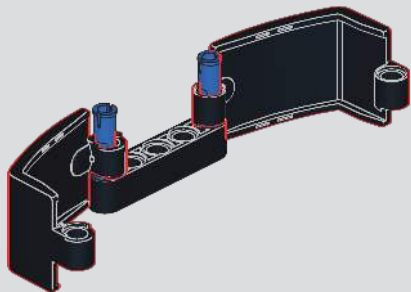

72

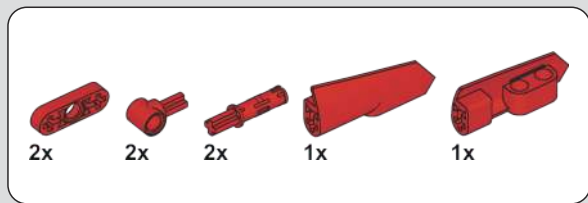
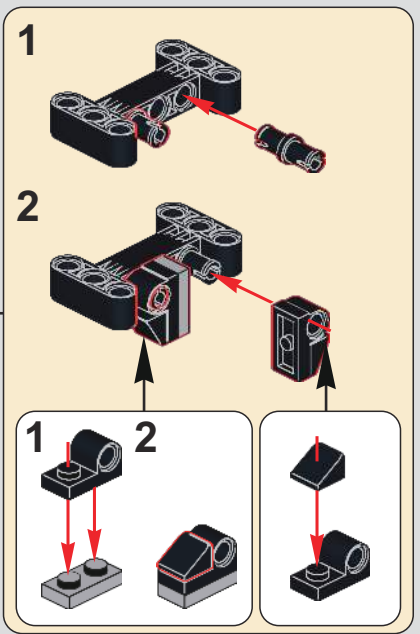
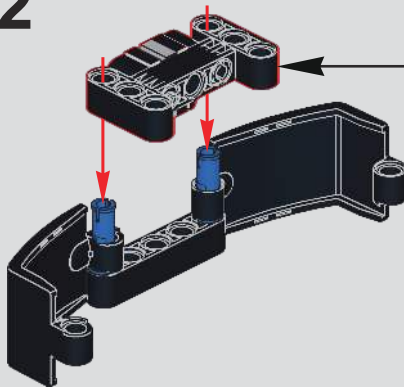

73

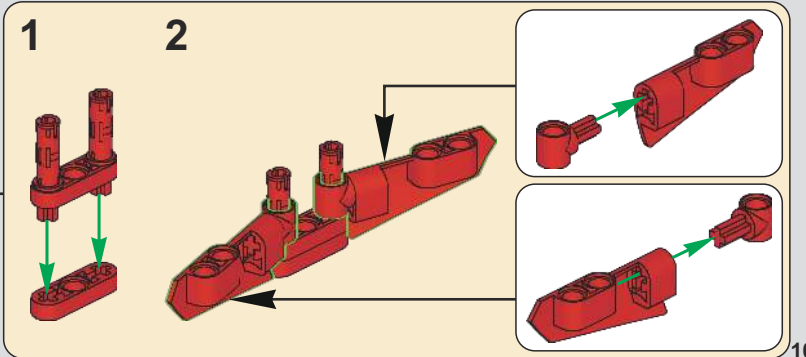
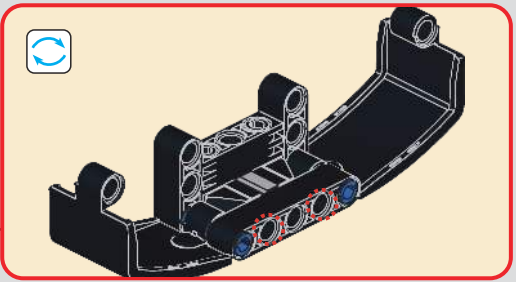
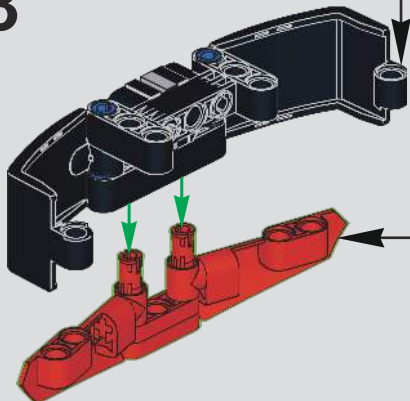

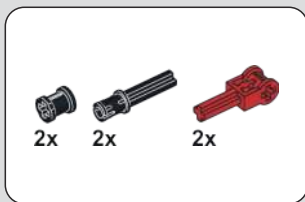

74

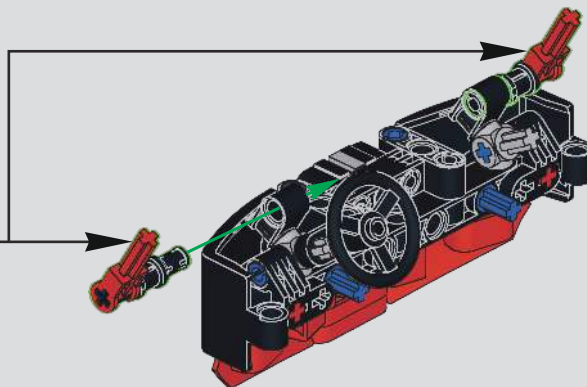
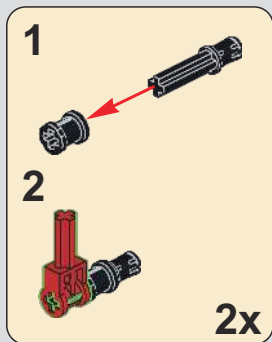

75

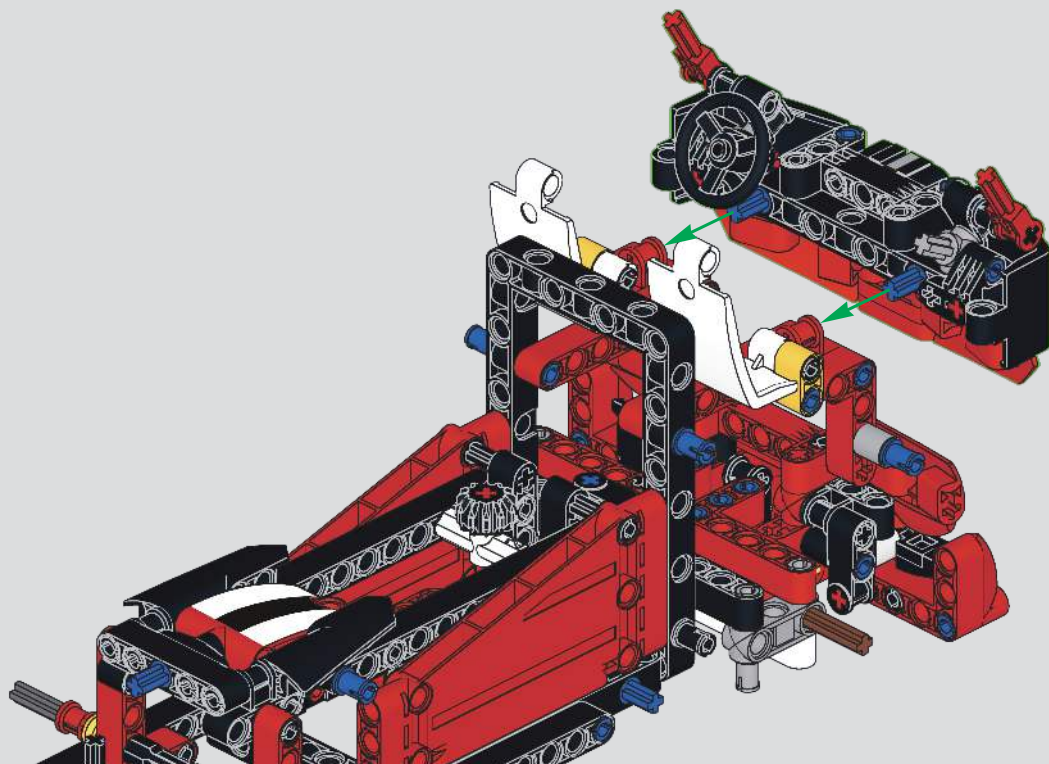

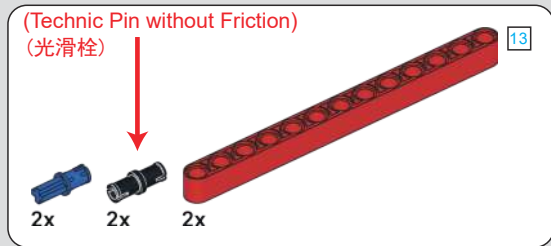

76

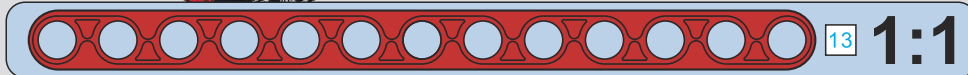
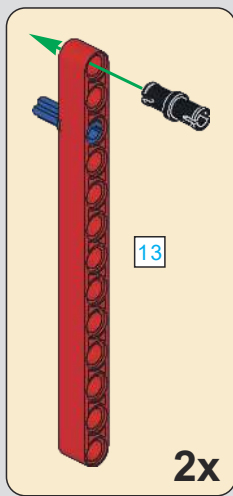
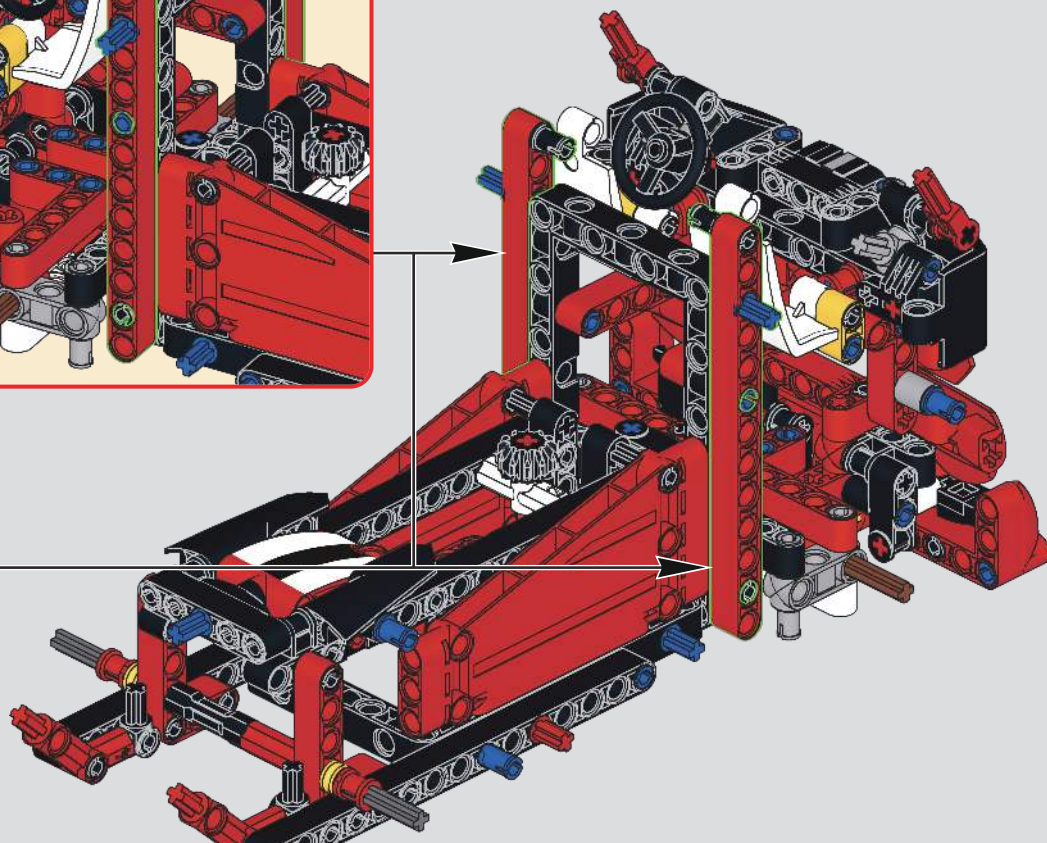
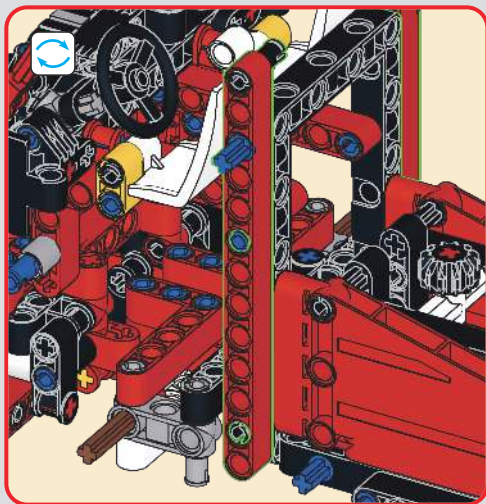

(Technic Pin without Friction)  
(光滑栓)



2x



2x



1x



1x

9

11

# 77

1

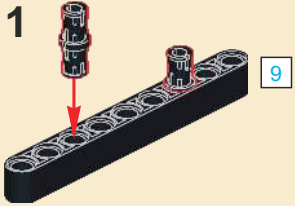

9

11

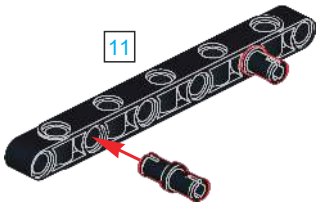

2

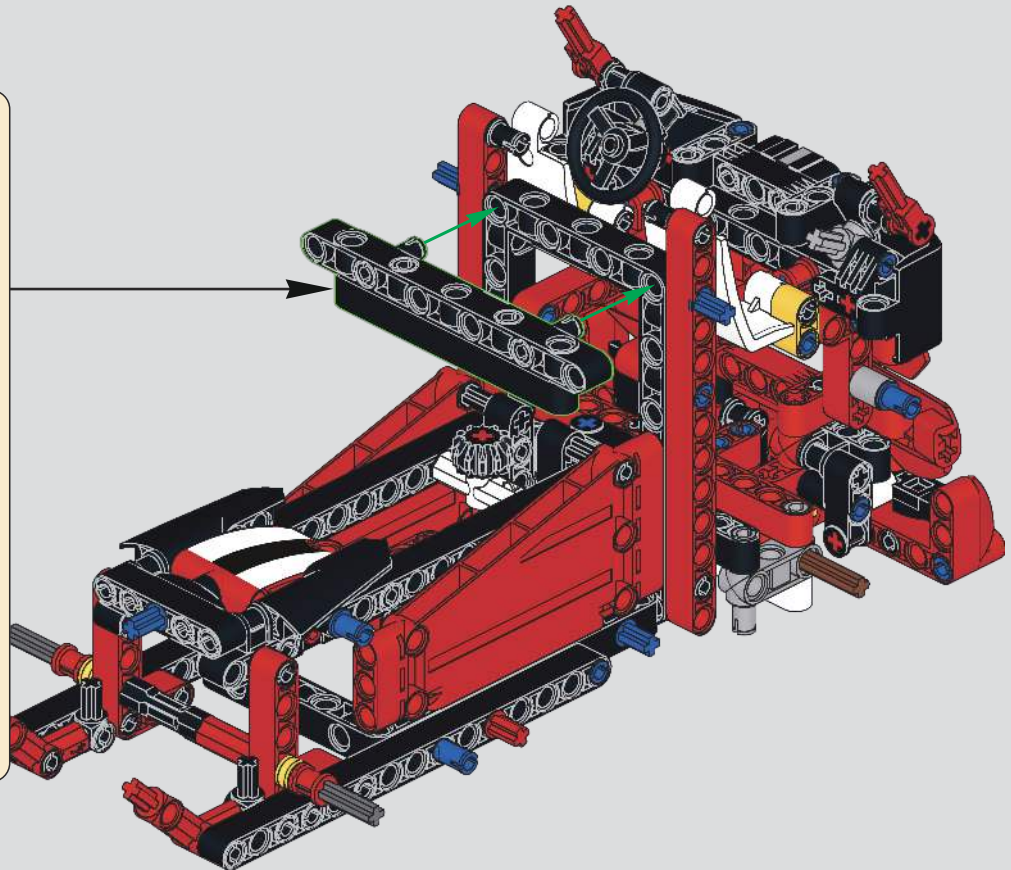
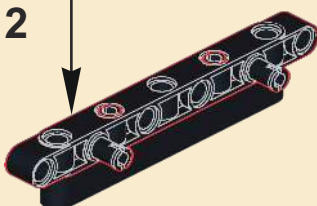

9



11

1:1

(Technic Pin without Friction)

(光滑栓)

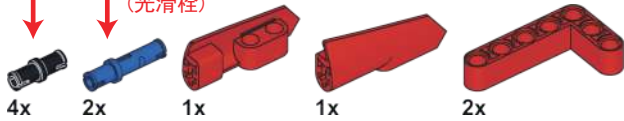

78

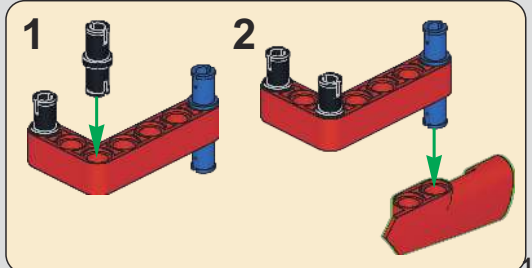
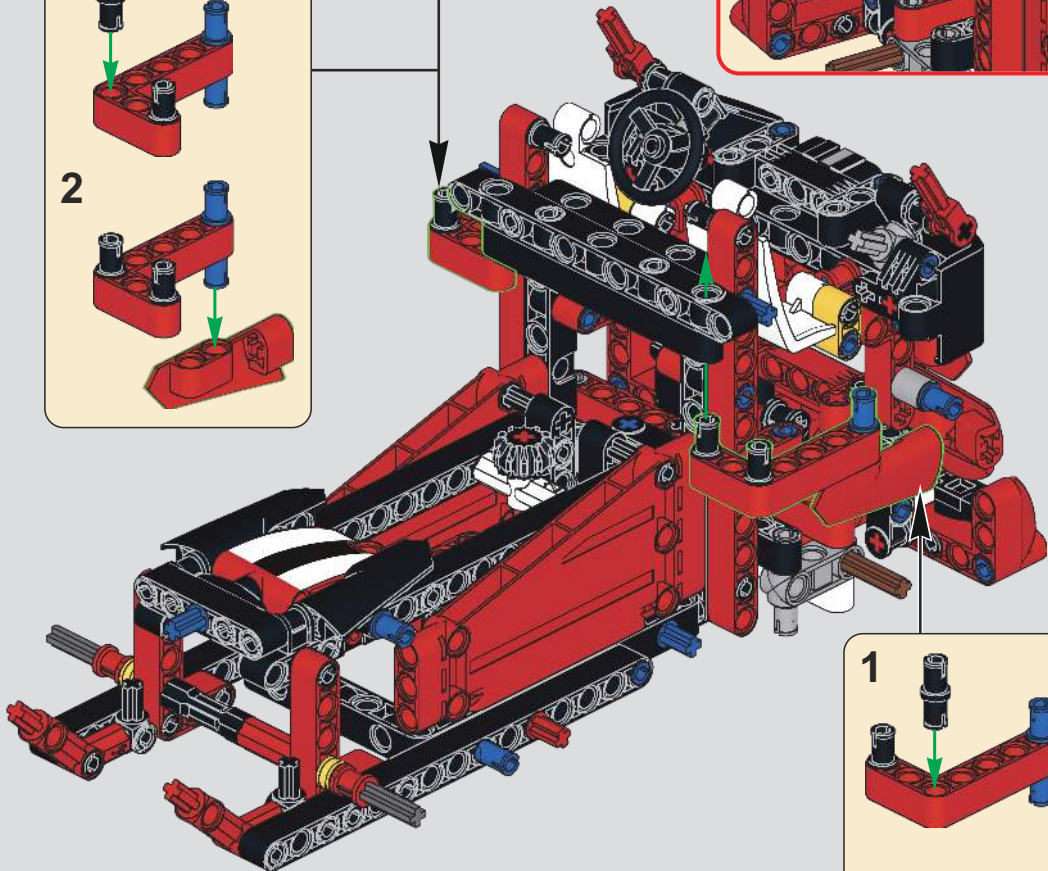
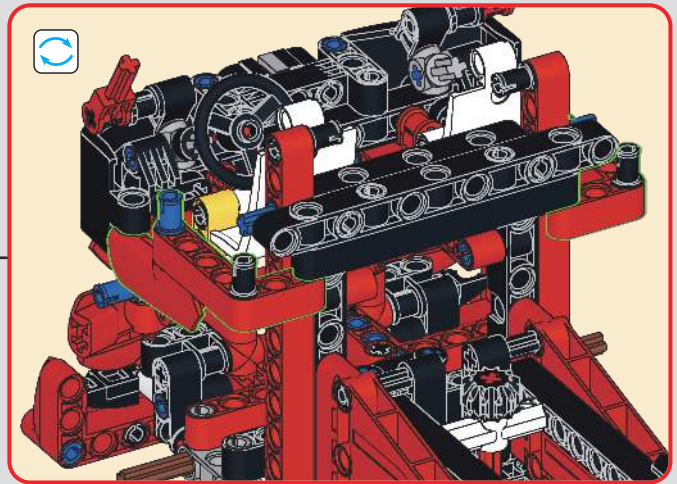
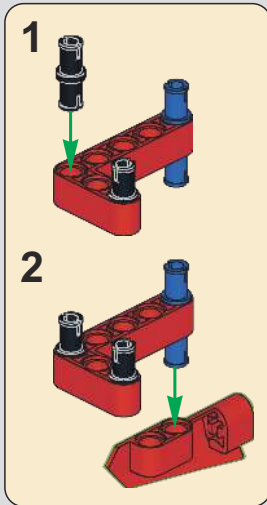

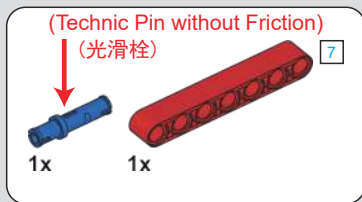
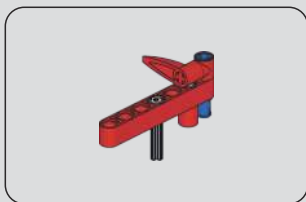

79



80

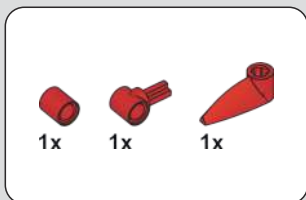
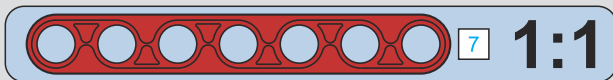
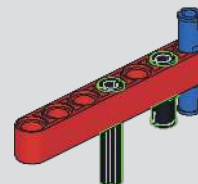
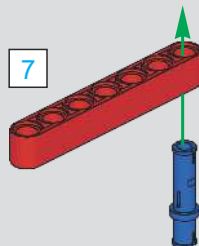

81

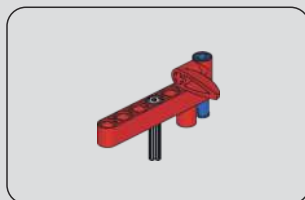

82

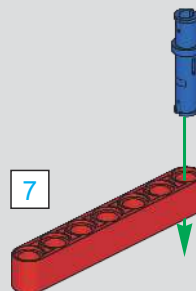
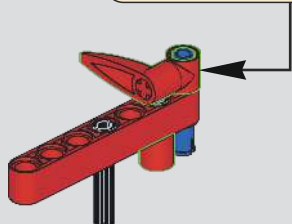
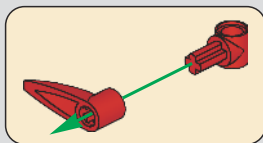



83

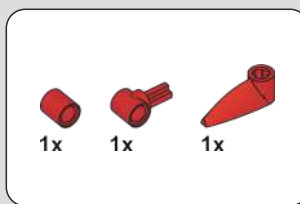
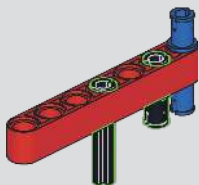

84

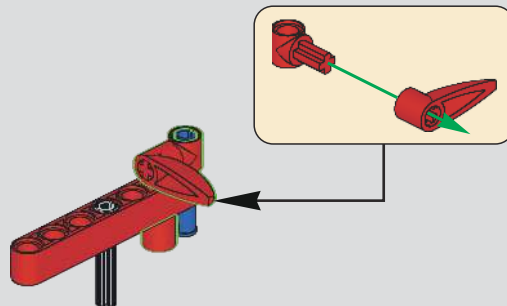

85

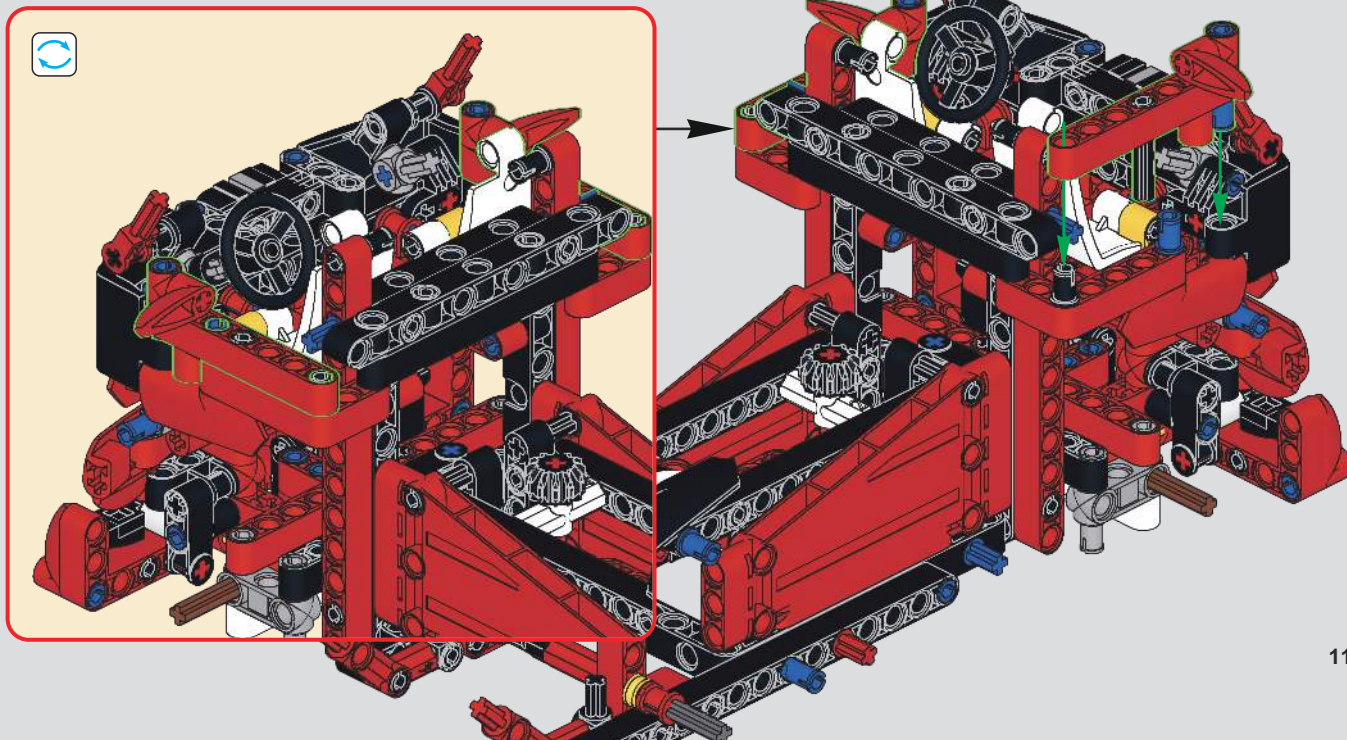

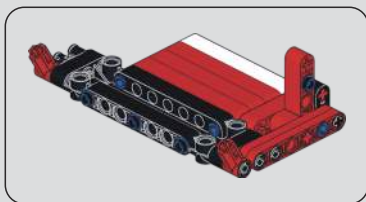

86



87

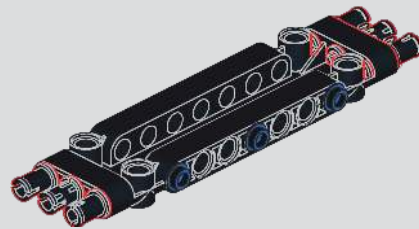
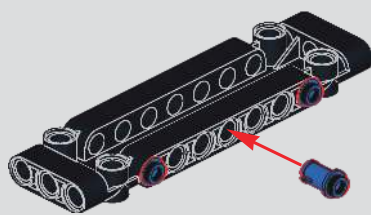

88

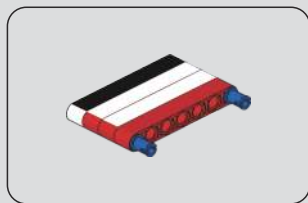

89

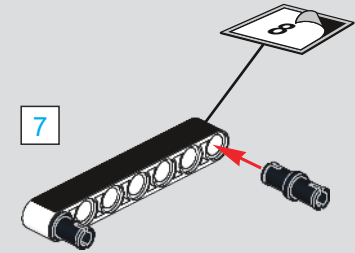
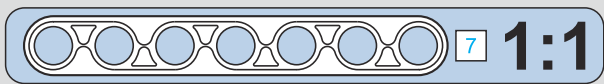
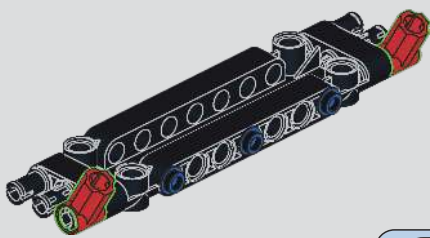



90

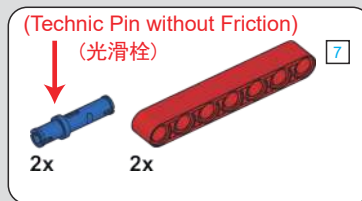
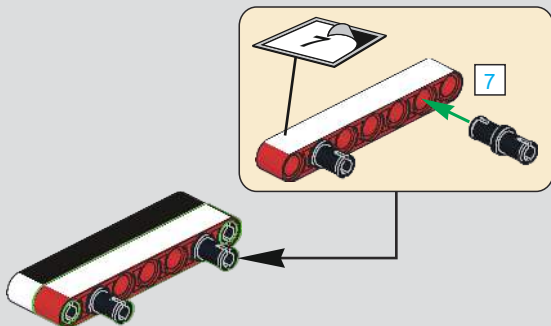

91

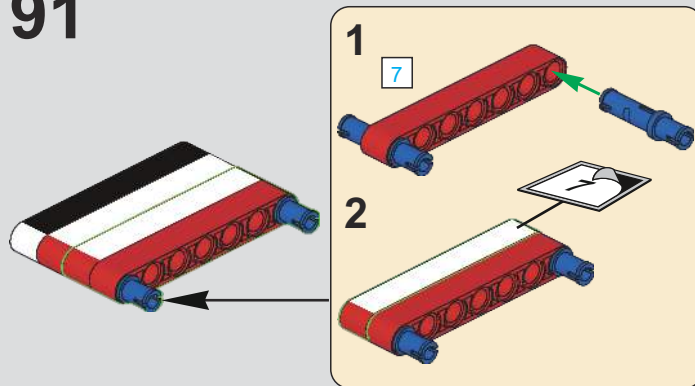

92

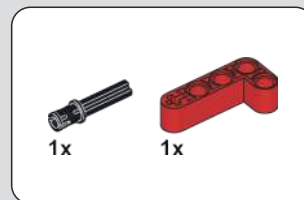
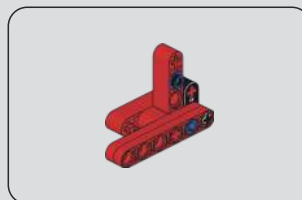
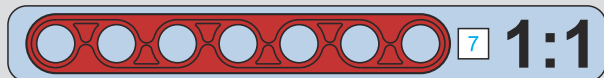
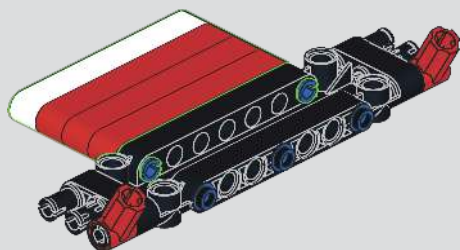

93

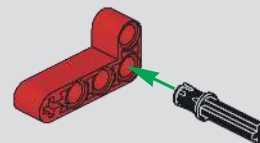

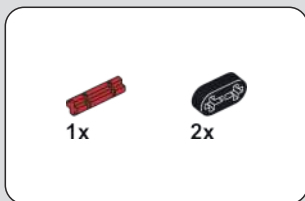

94

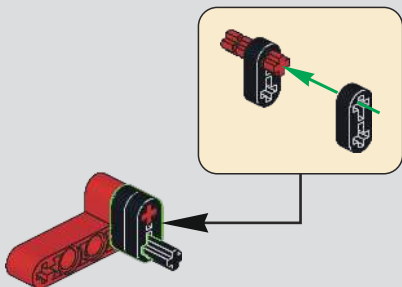

95

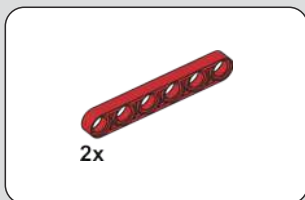
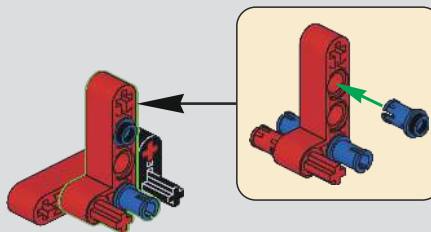

96

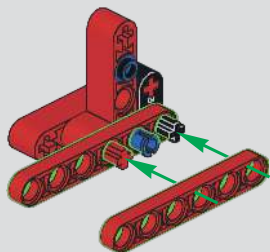

97

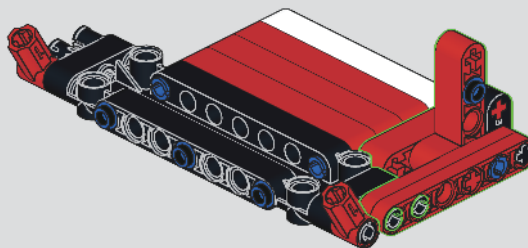

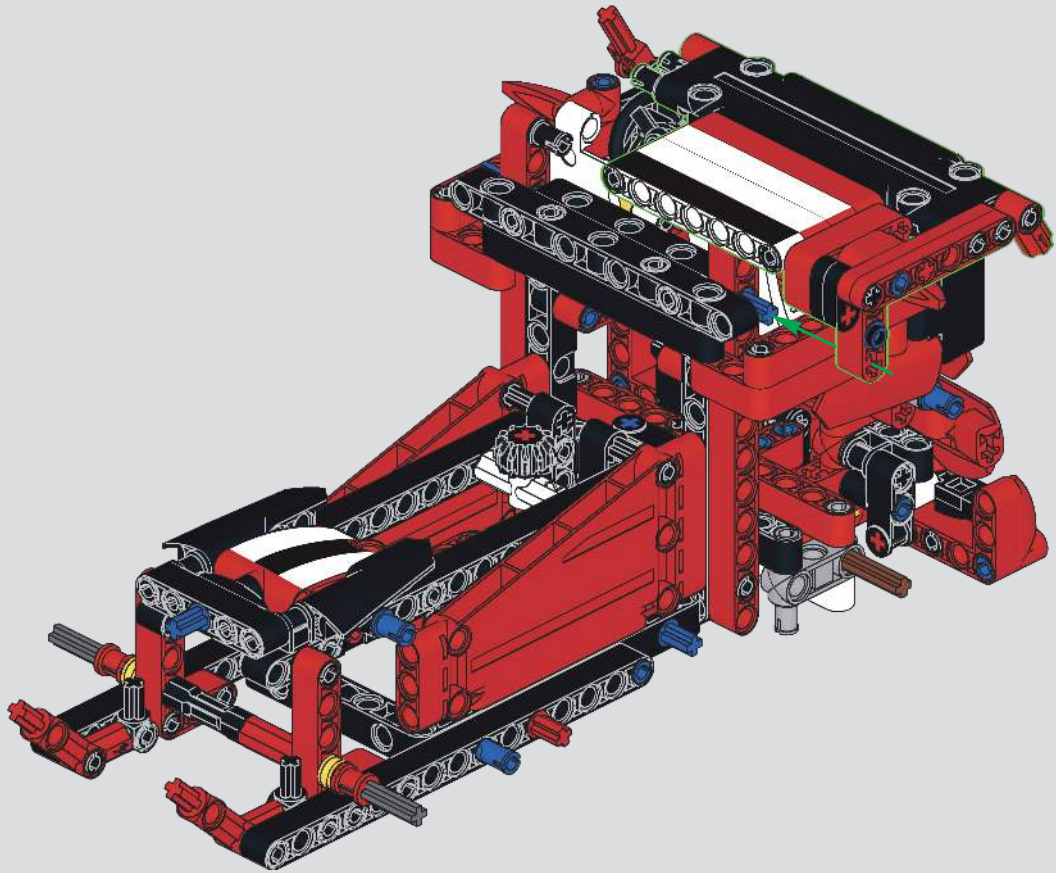

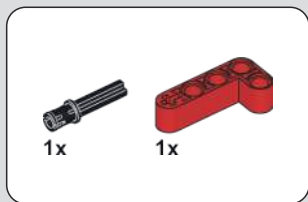

99

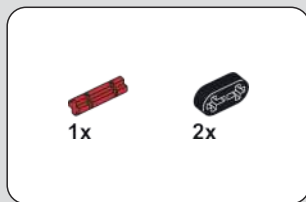

100

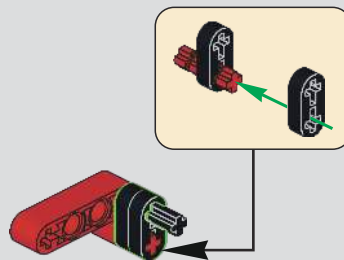
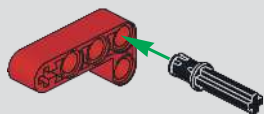

101

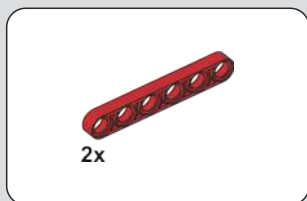

102

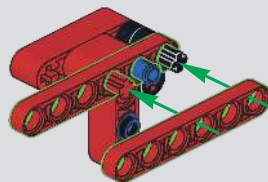
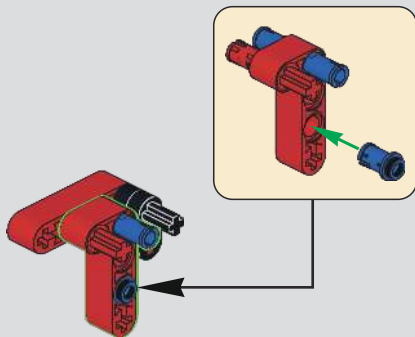

# 103

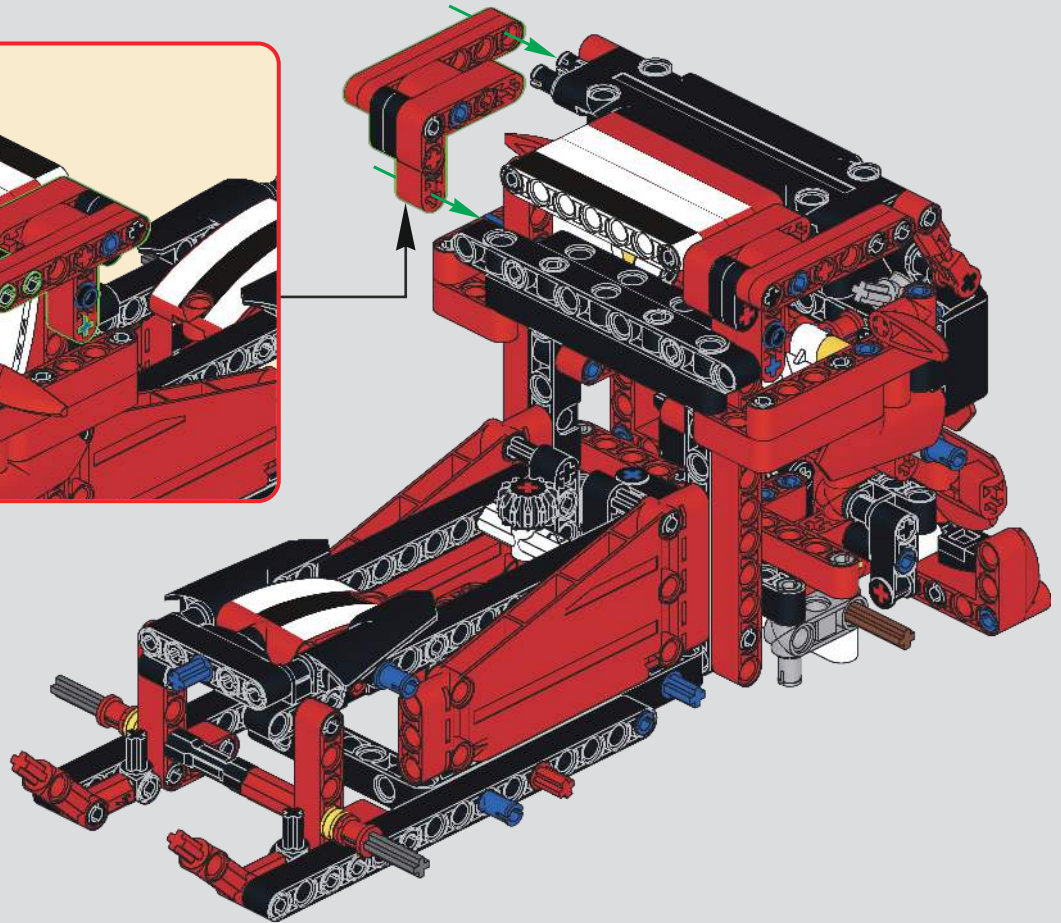
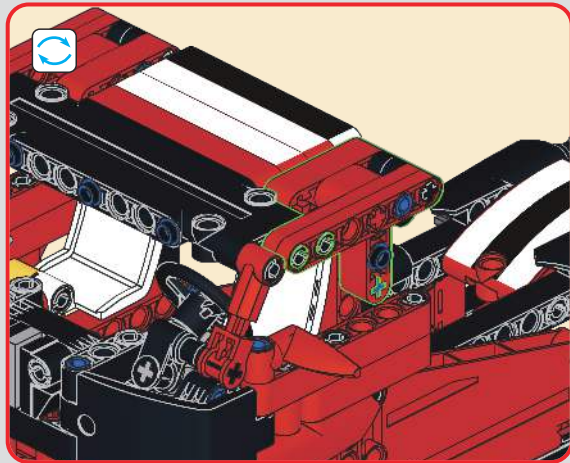

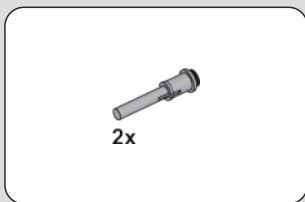

104

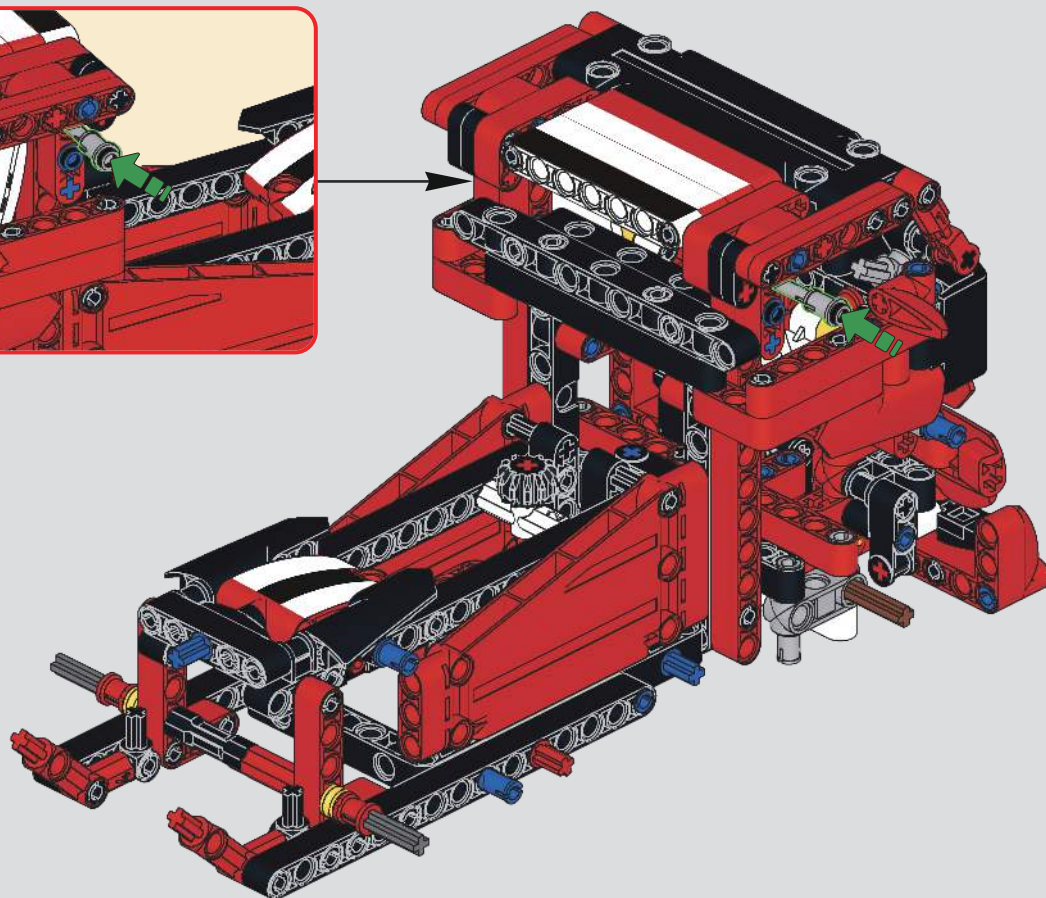
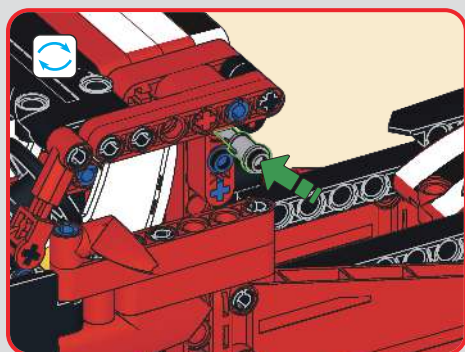

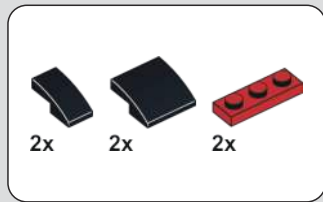

105

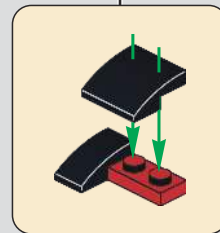
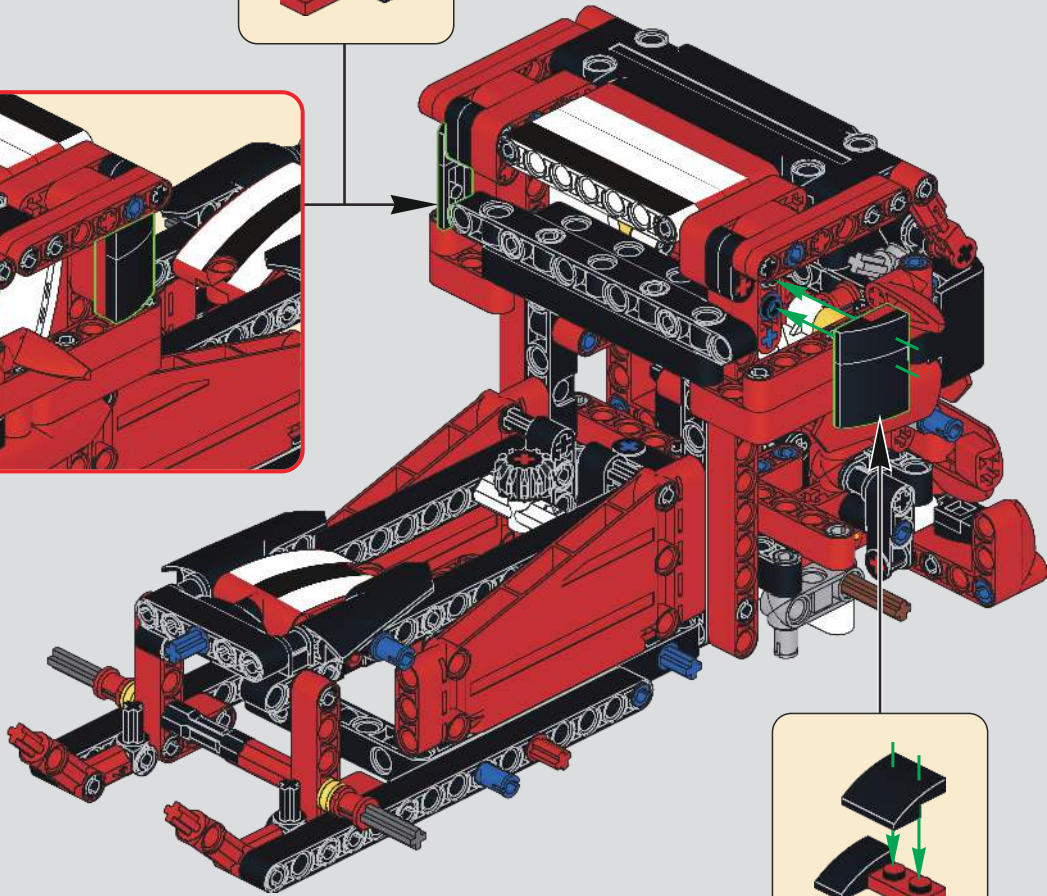
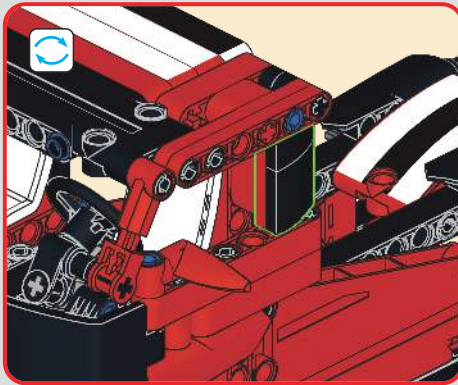
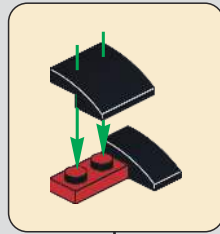



110

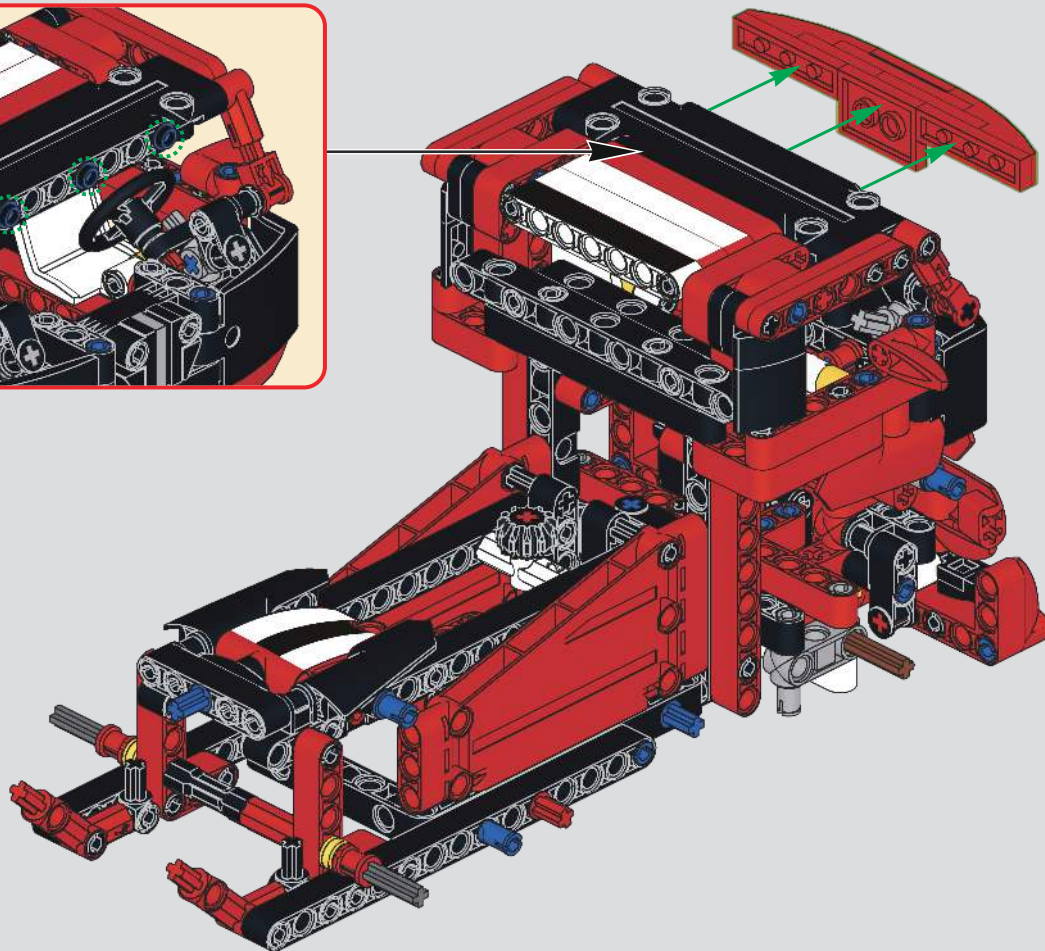
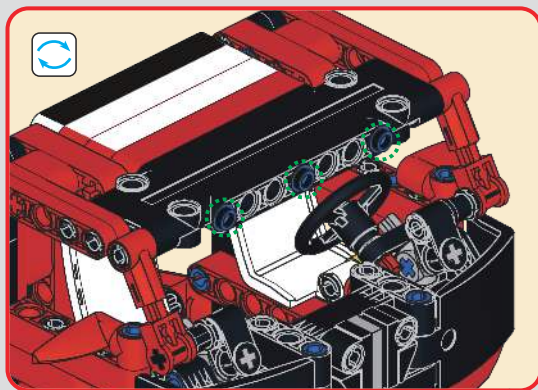

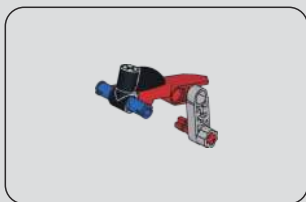

111



112

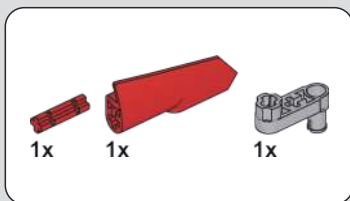
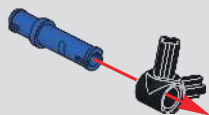

113

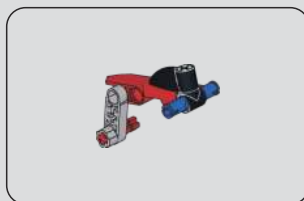

114

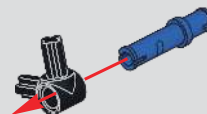
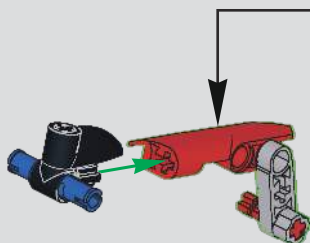
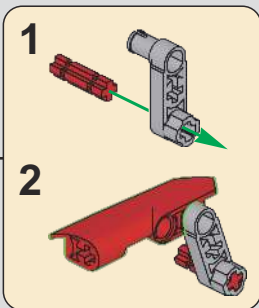

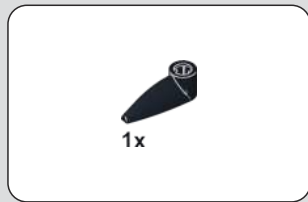

115

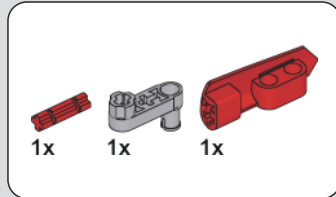

116

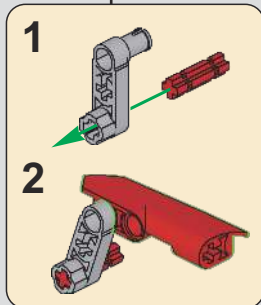
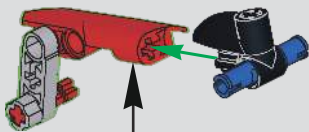

117

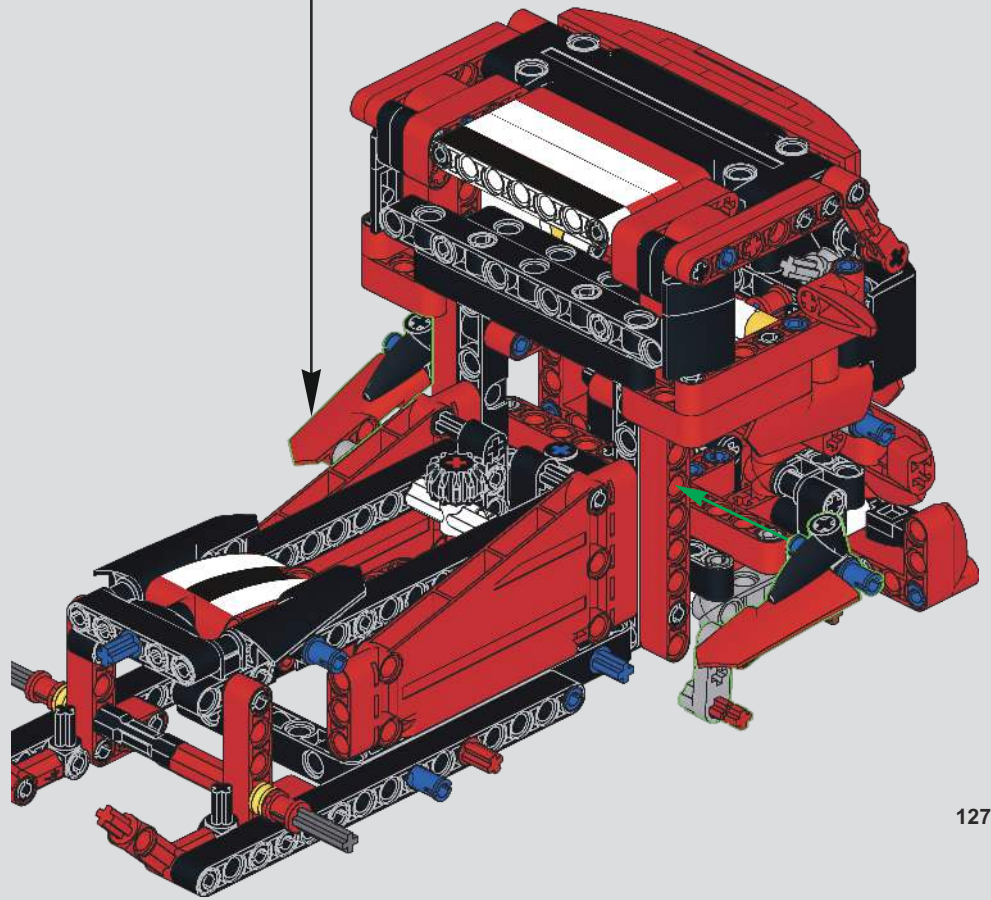
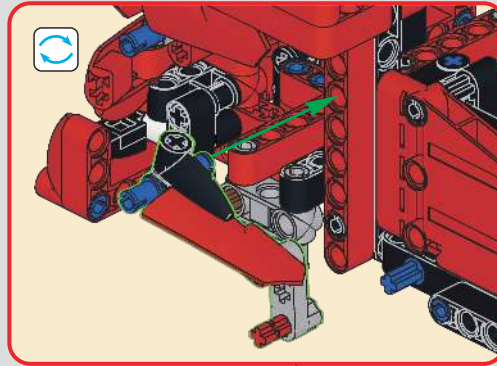

(Technic Pin without Friction)

(光滑栓)

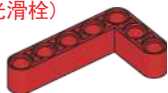

2x

2x

# 118

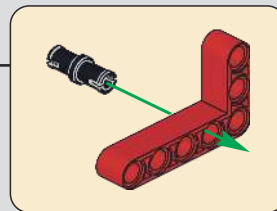
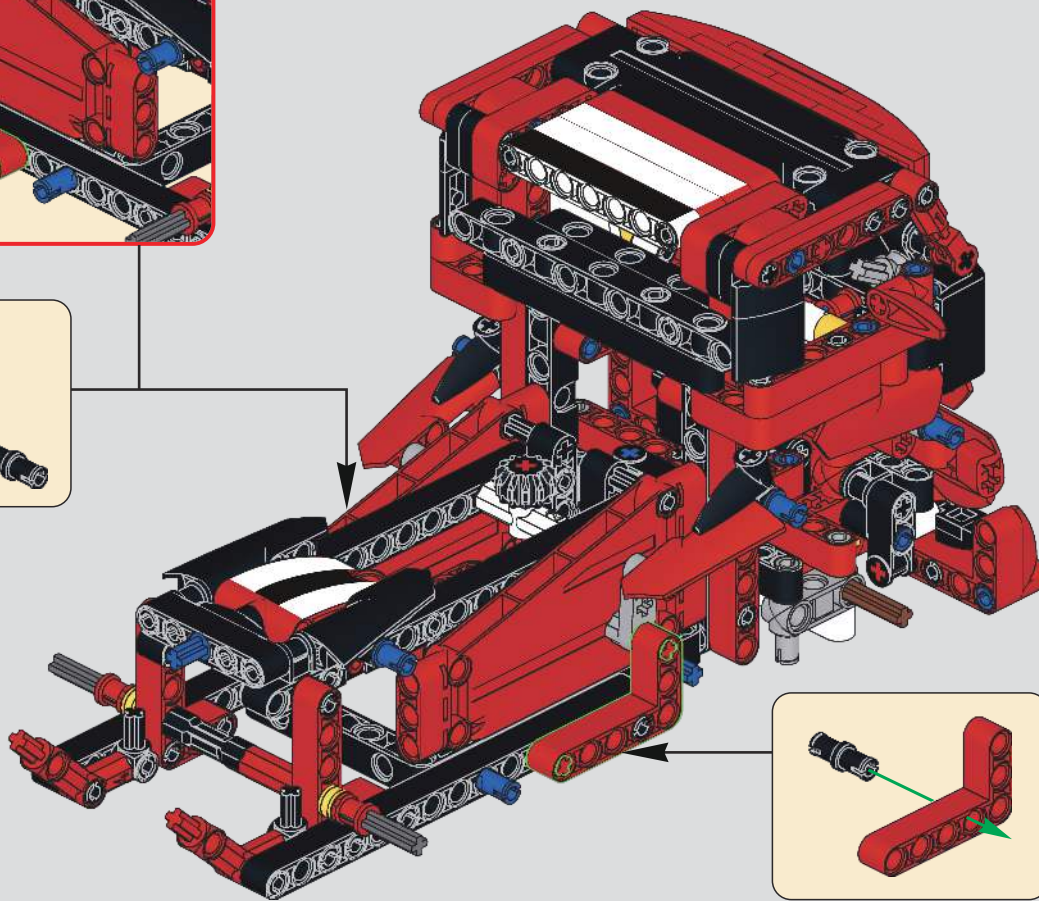
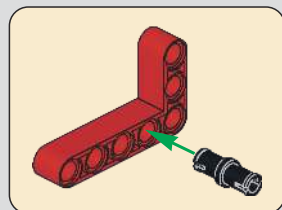
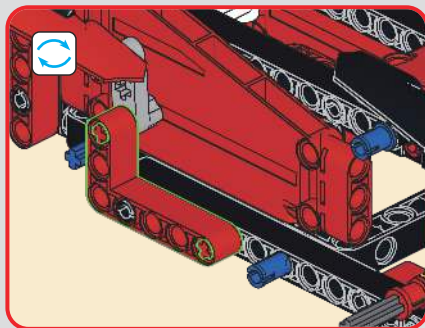



# 119

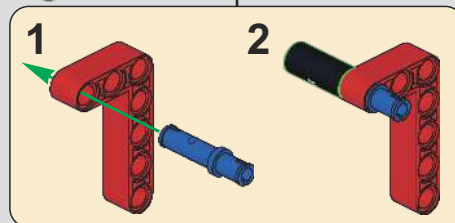
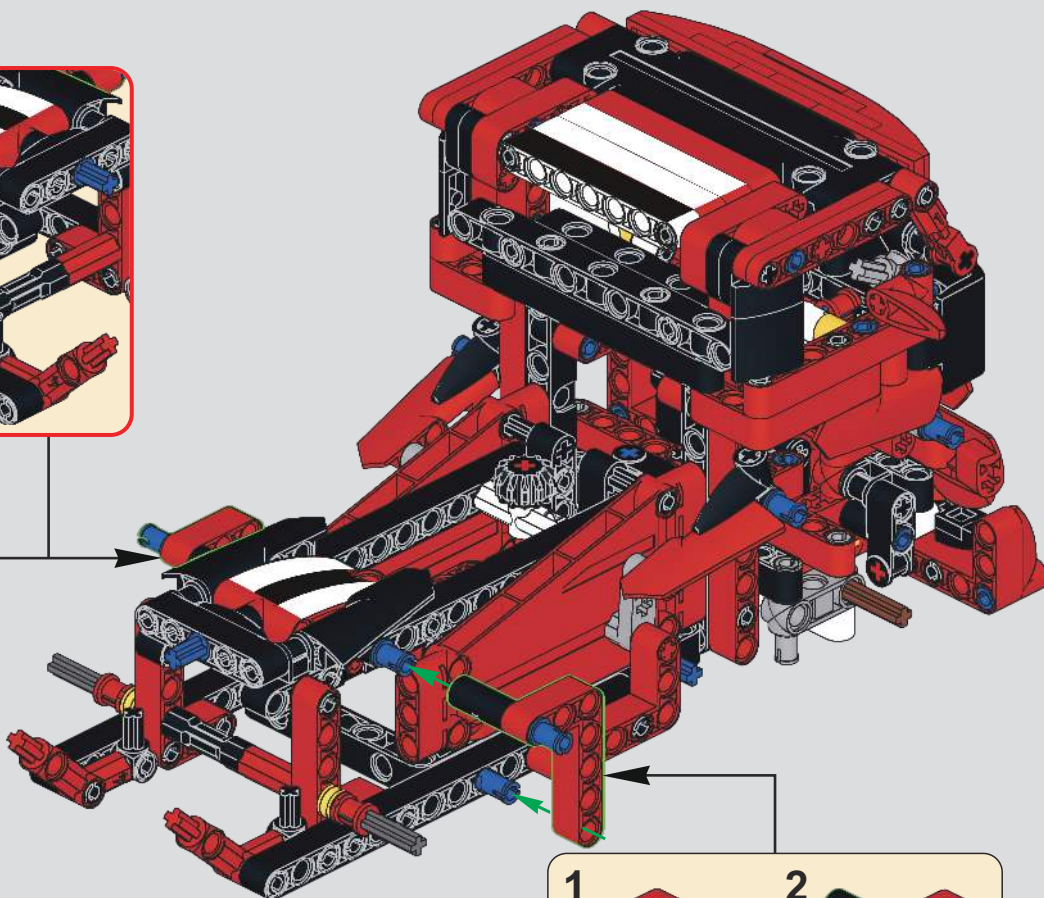
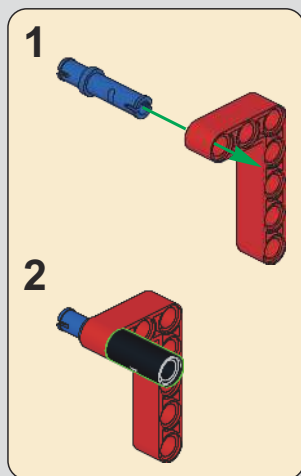
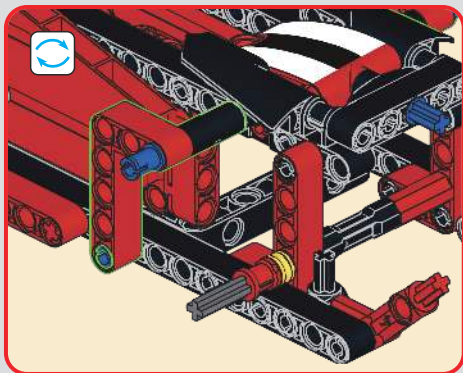

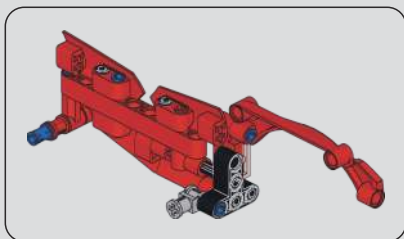

120

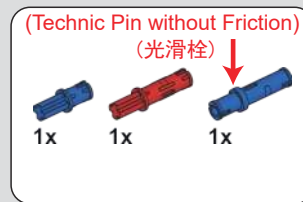

121

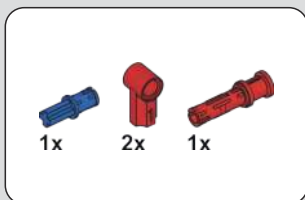
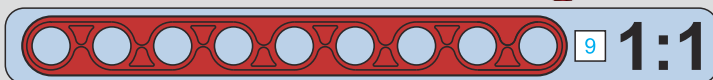
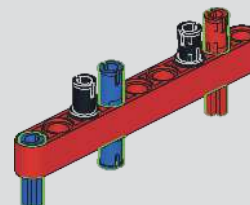
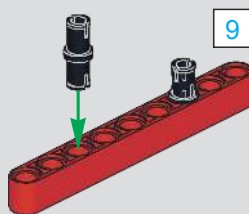

122

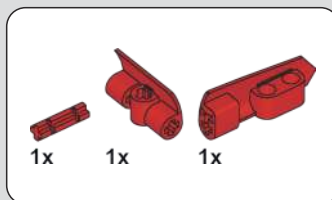

123

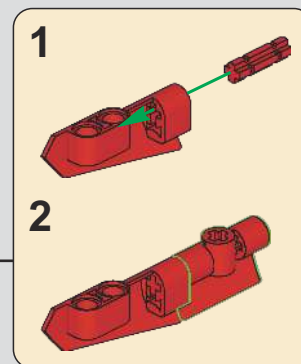
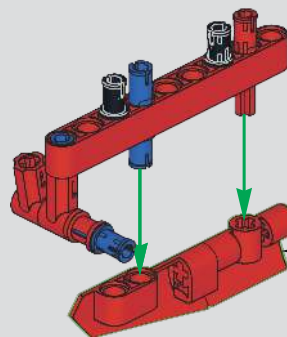
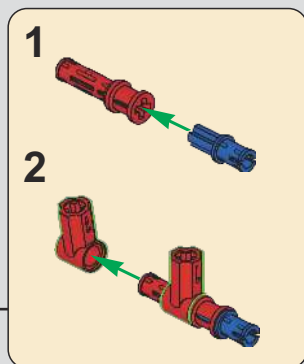
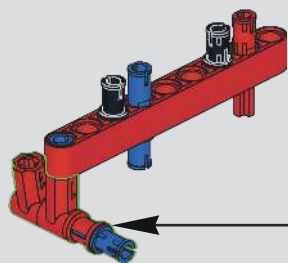

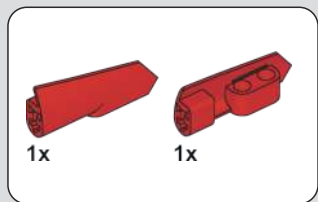

124

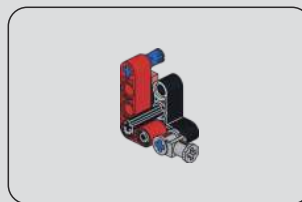
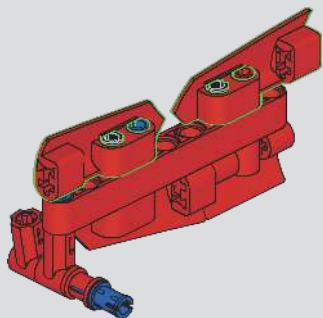

125

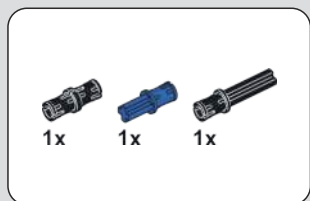
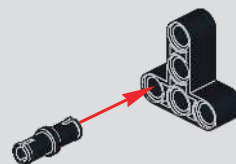

126

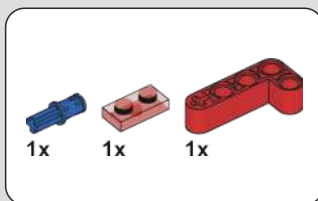
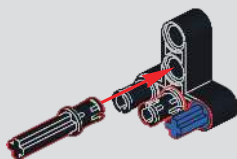

127

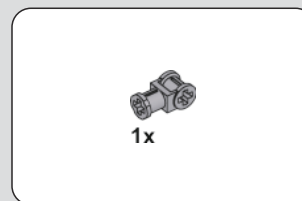
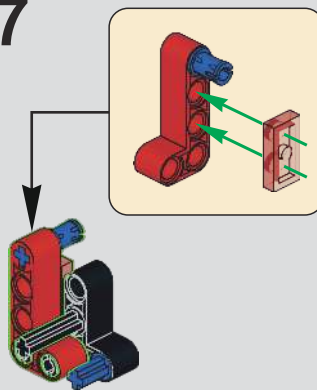

128

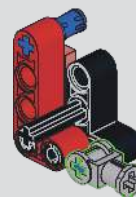

# 129

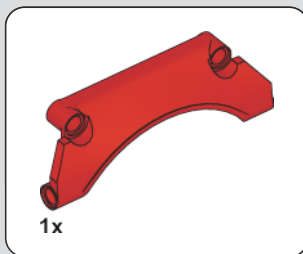

# 130

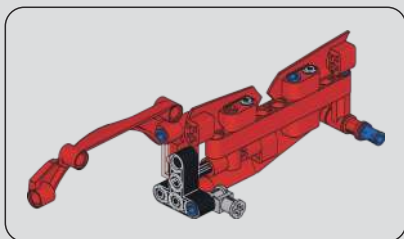
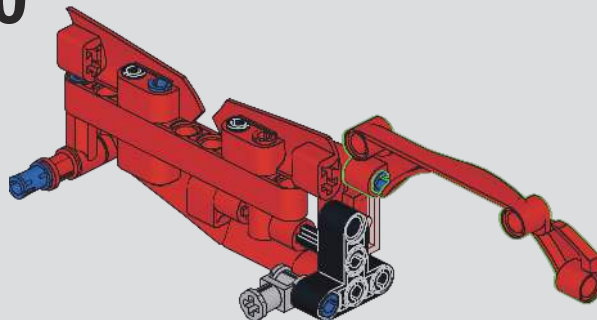
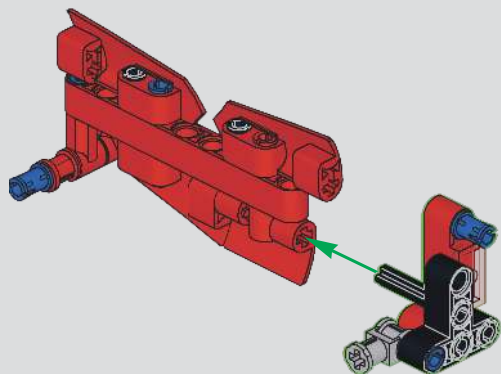

# 131

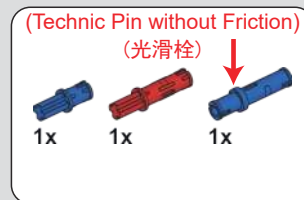

# 132

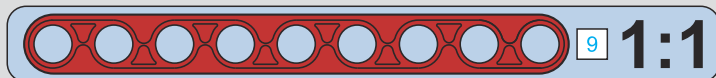
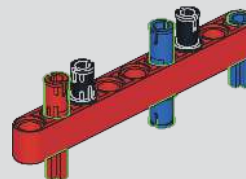
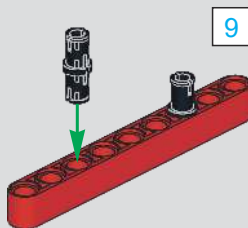

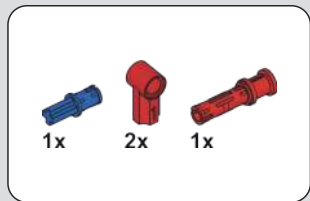

133

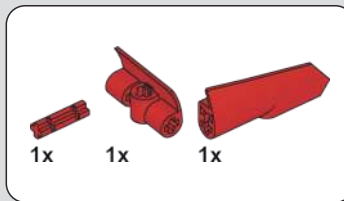
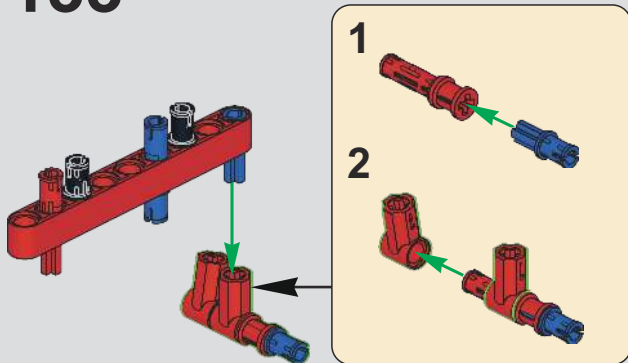

134

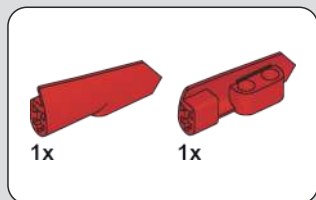
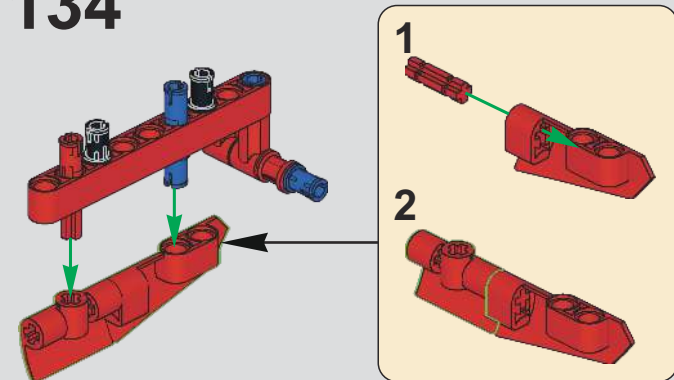

135

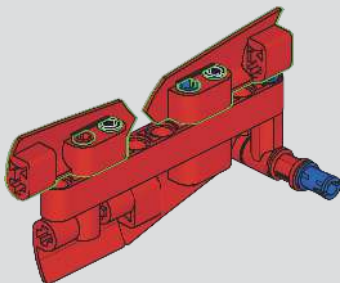

136

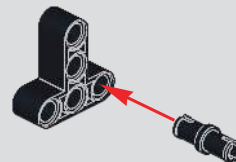

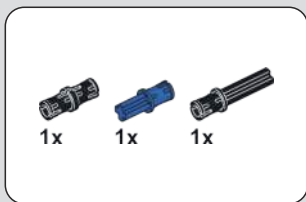

137

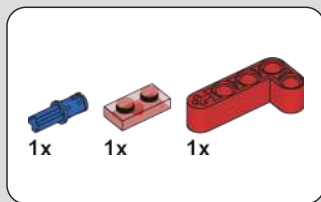
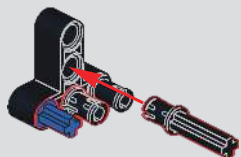

138

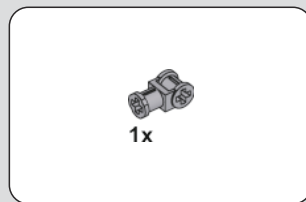
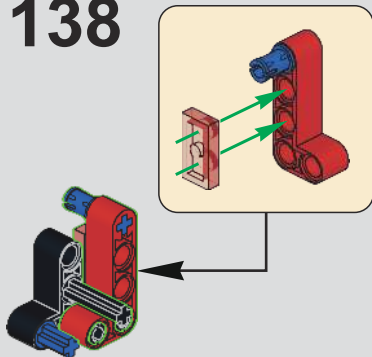

139

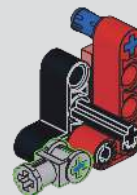

140

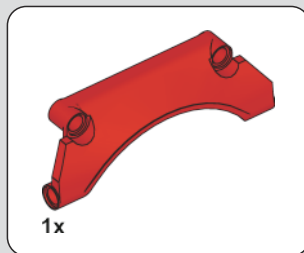
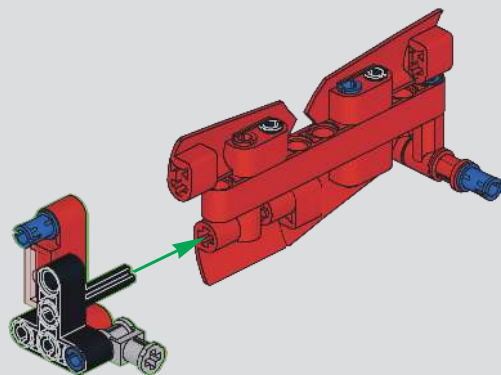

141

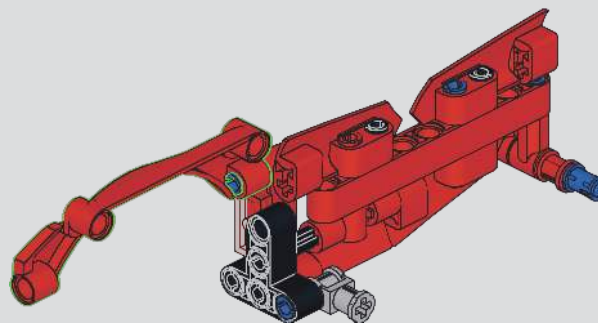

142

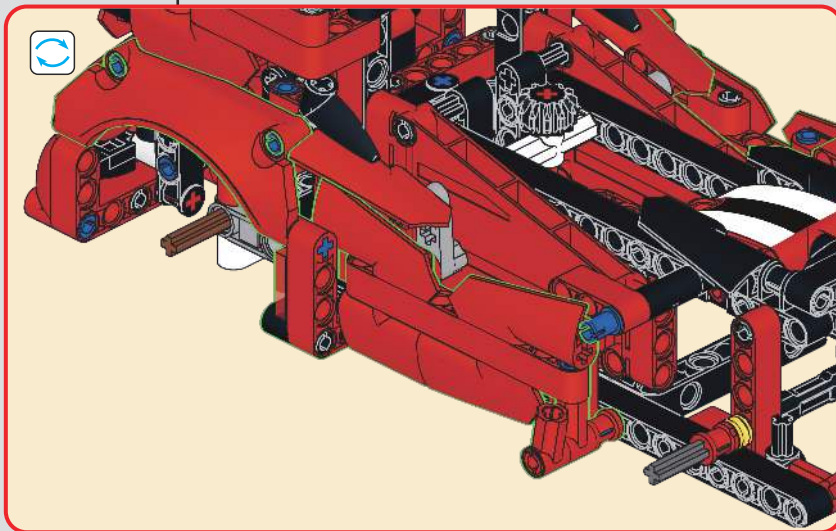
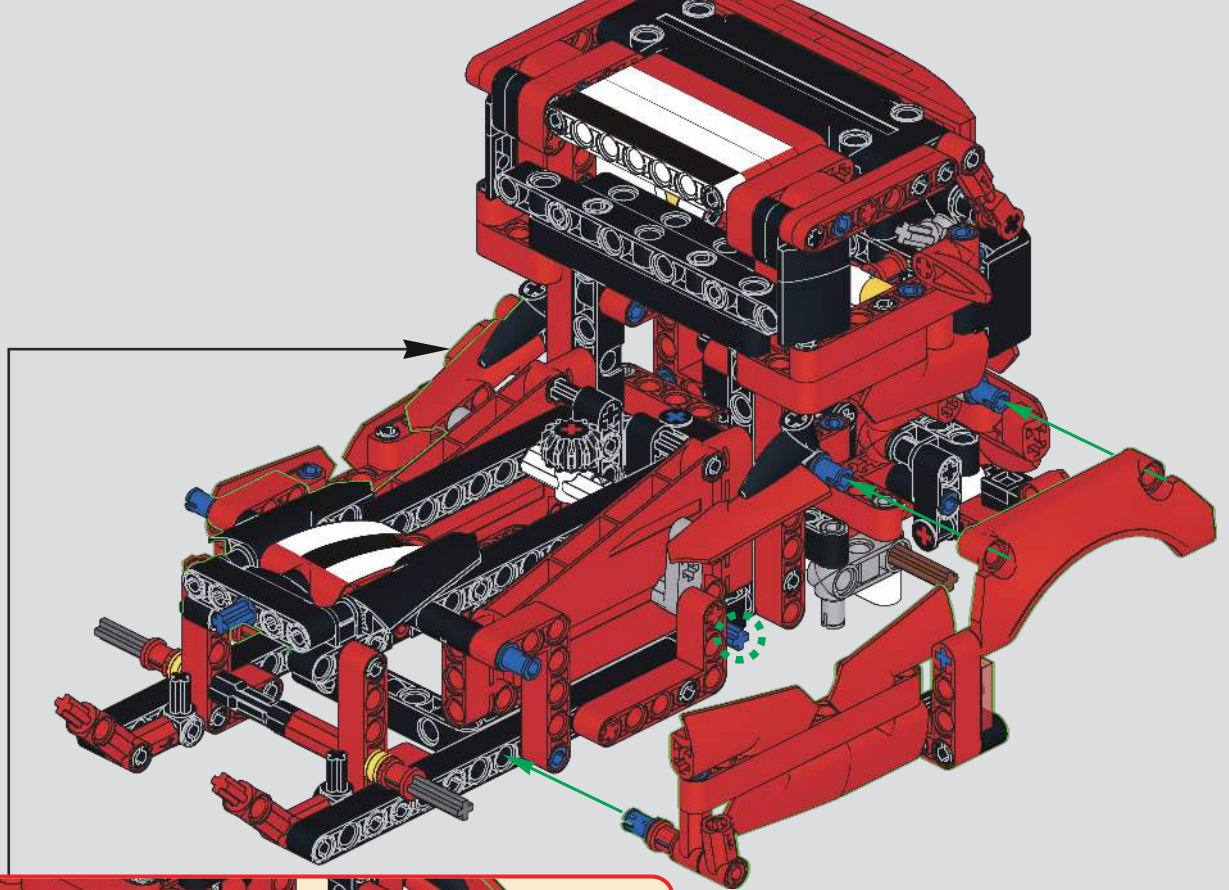

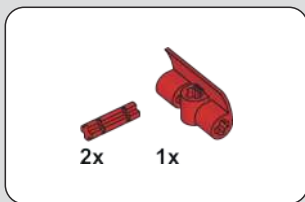

143

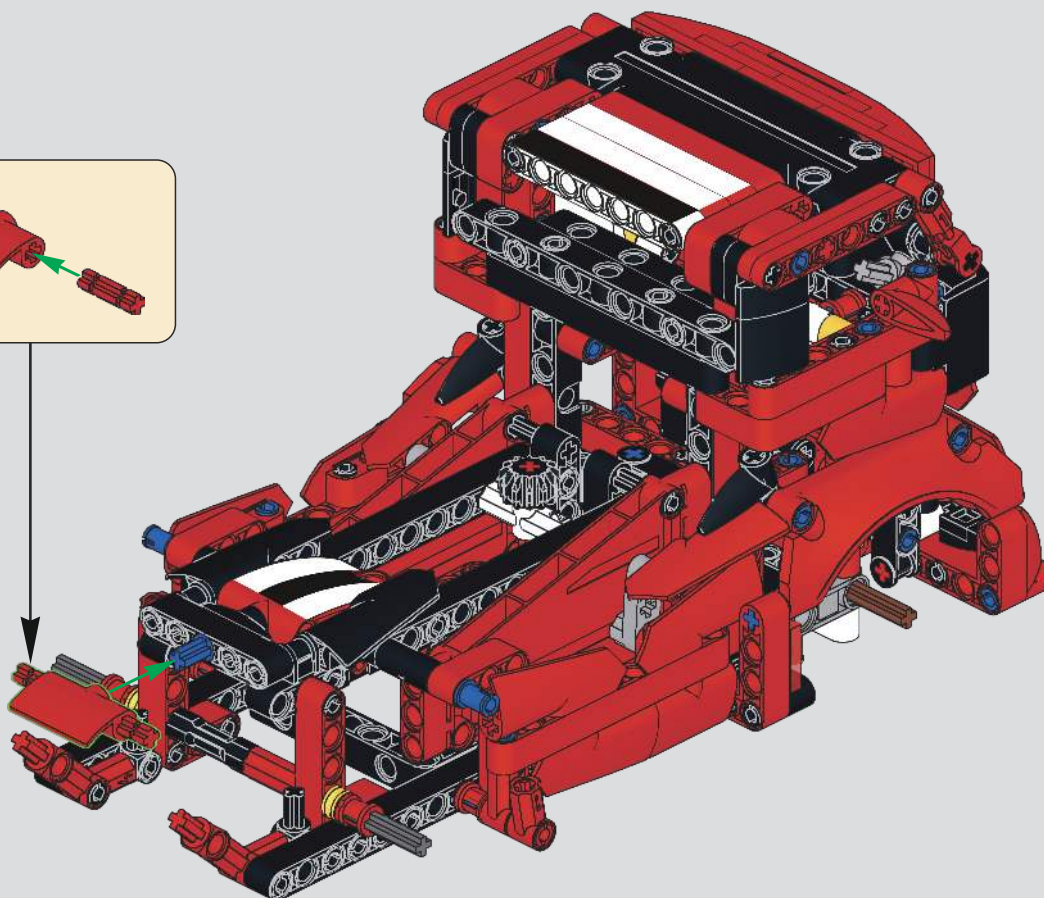
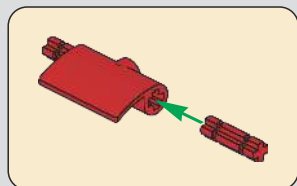

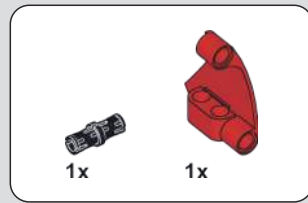
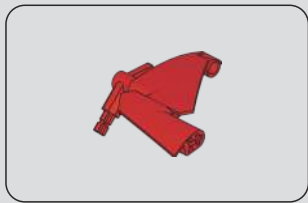

144



145

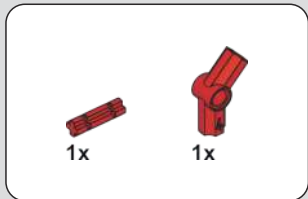
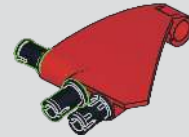
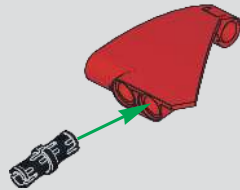

146

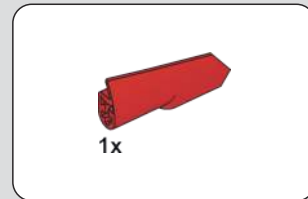
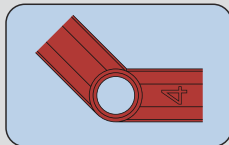

147

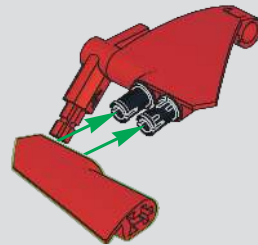
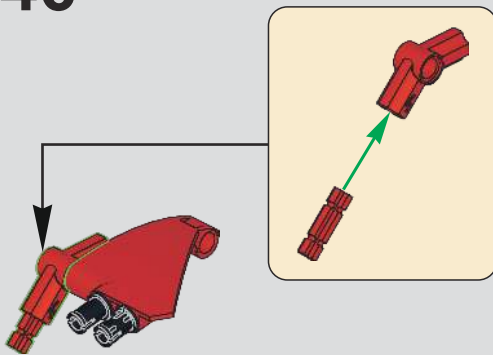



148



149

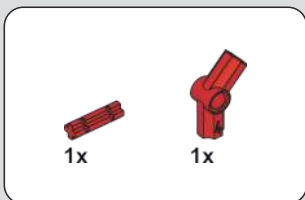
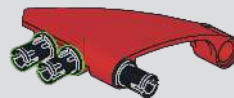
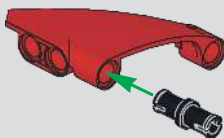

150

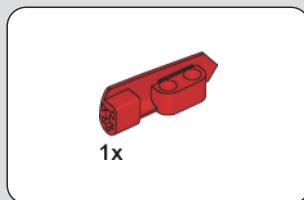
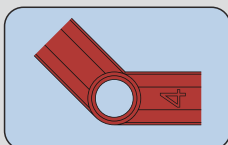

151

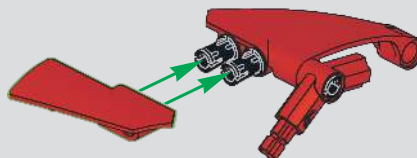
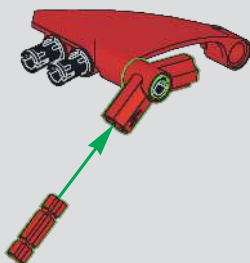

152

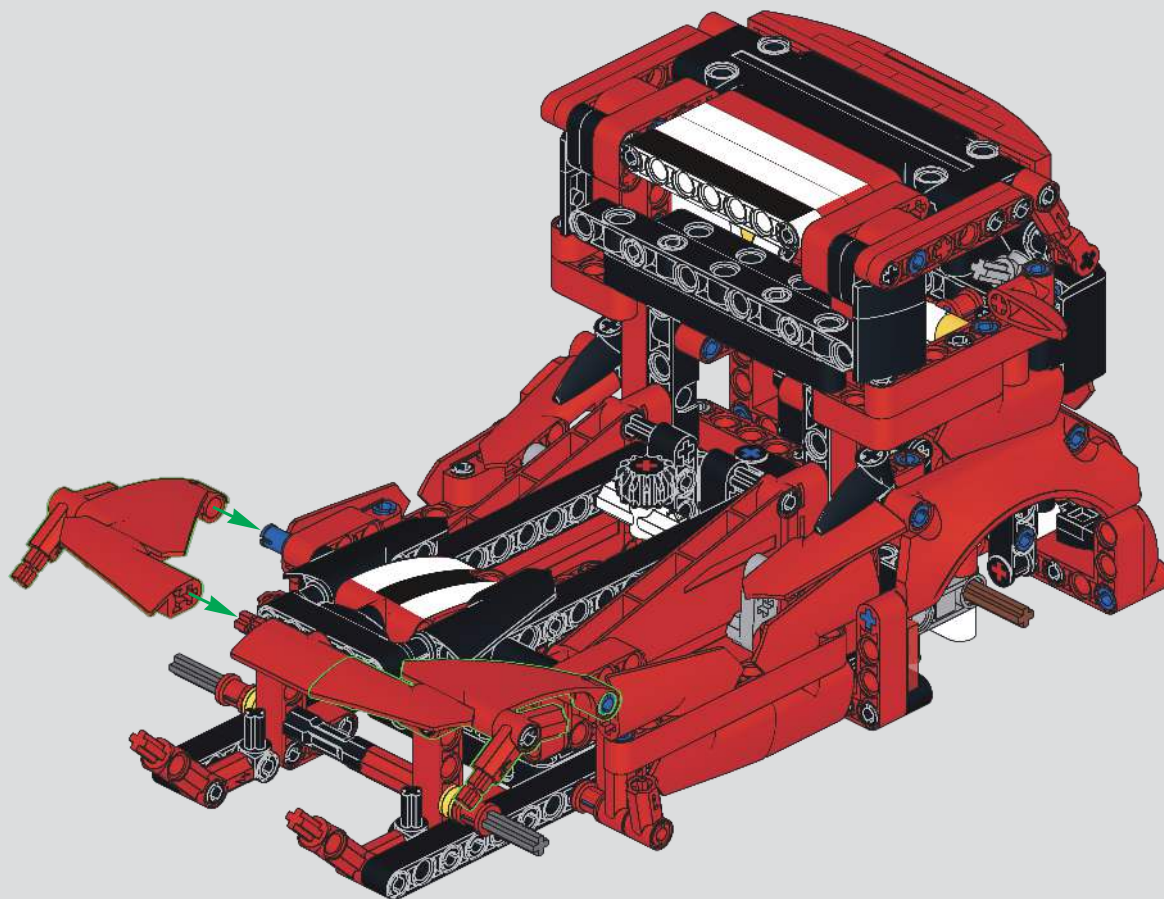

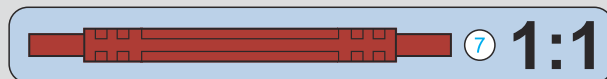

153

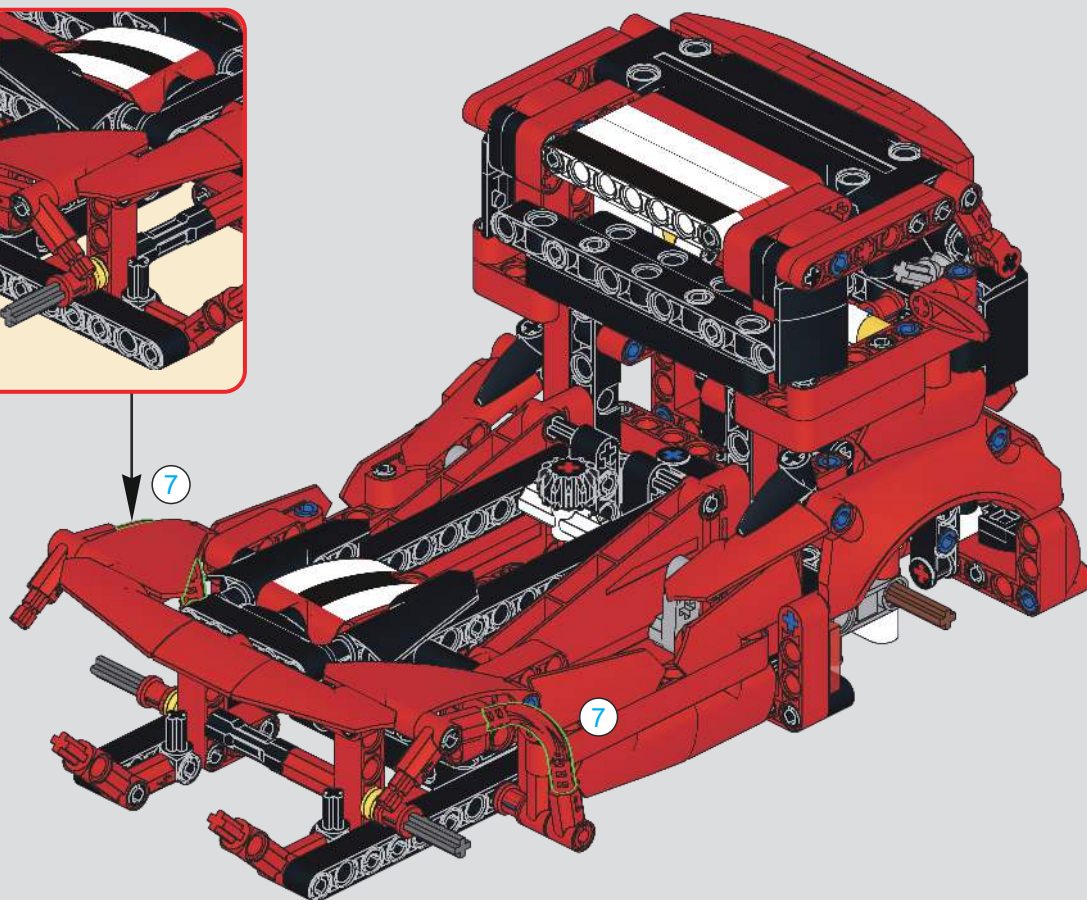
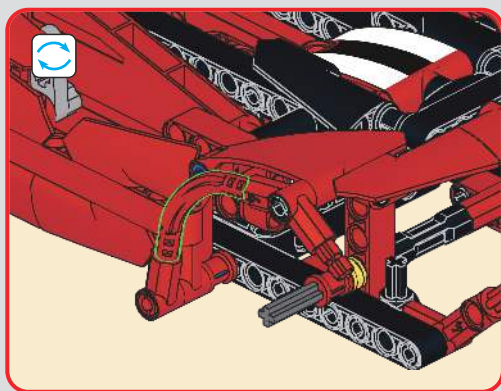

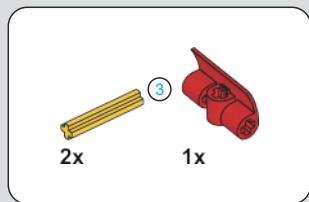
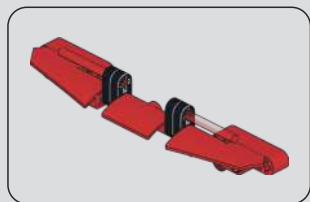

154

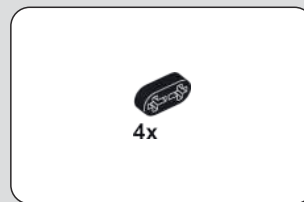

155

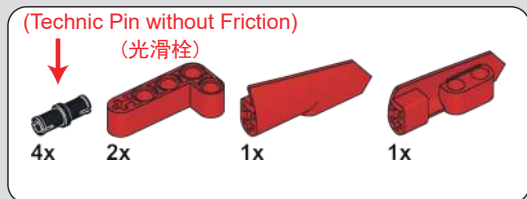
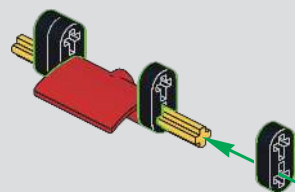
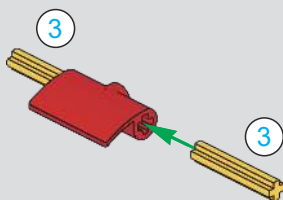
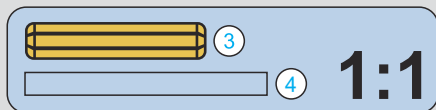

156

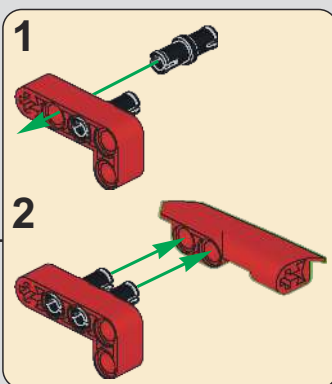
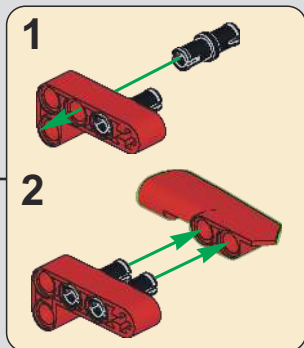

157

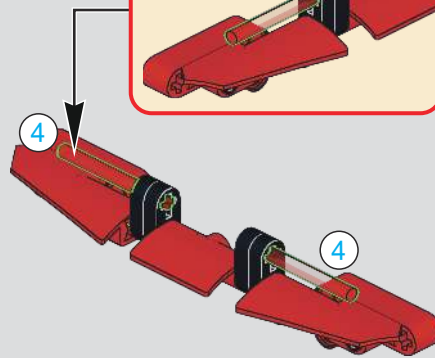
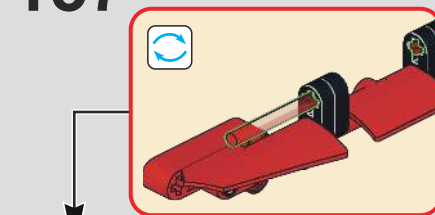

158

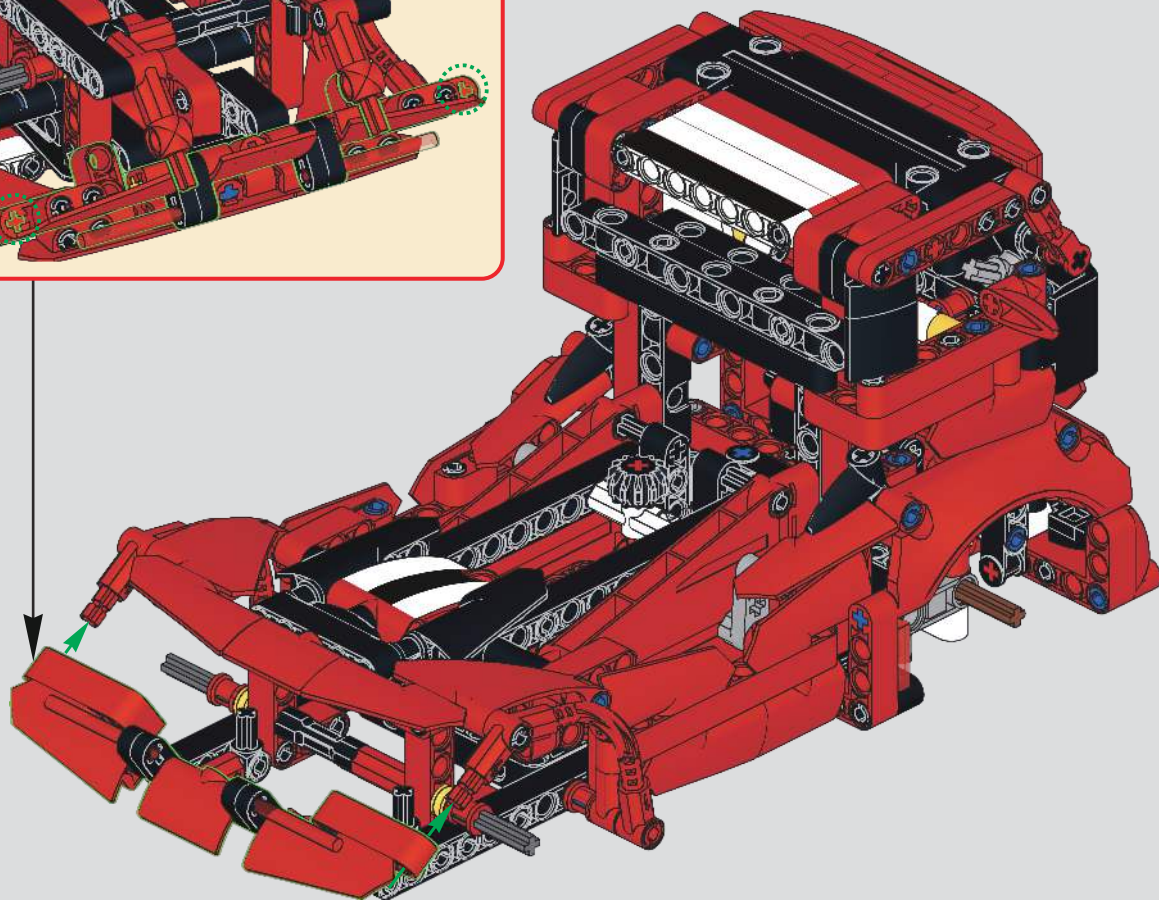
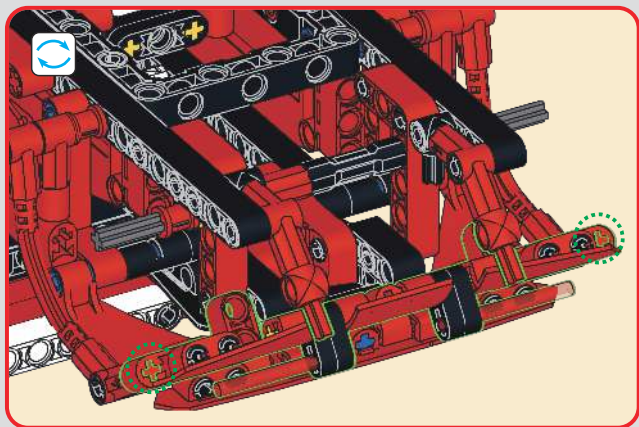

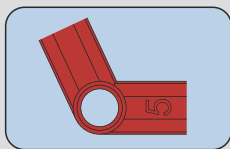
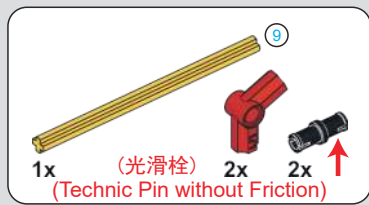

159

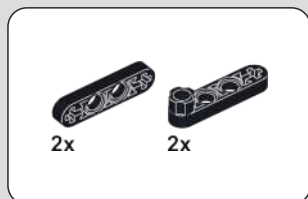
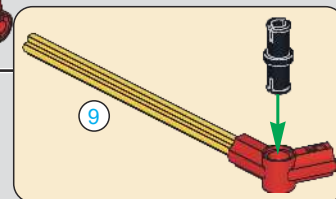
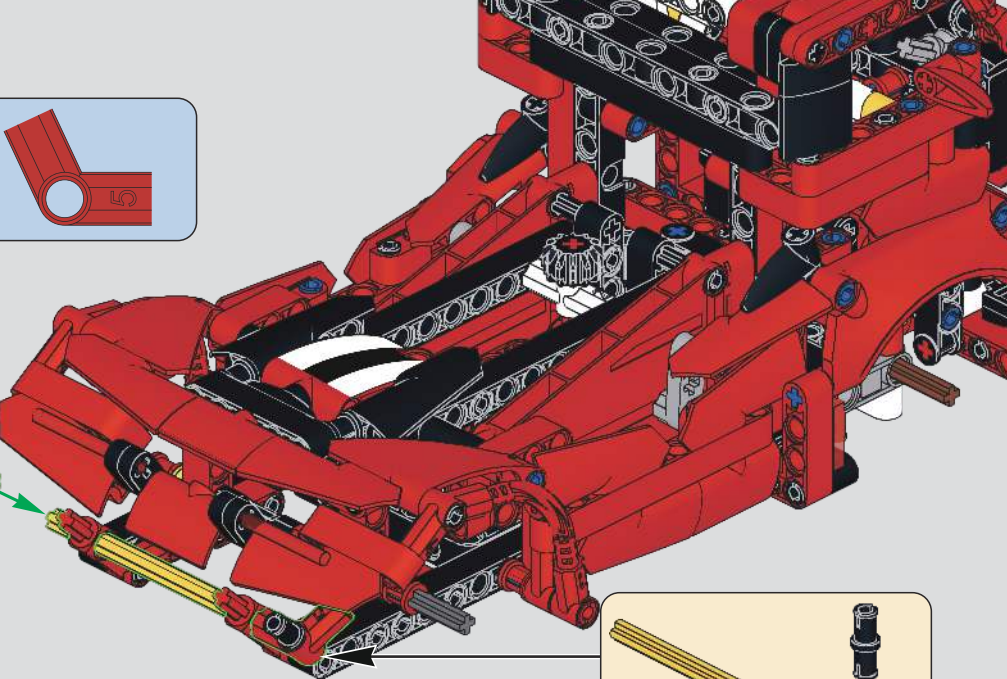
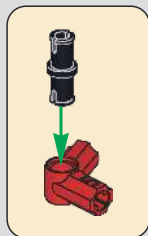

160

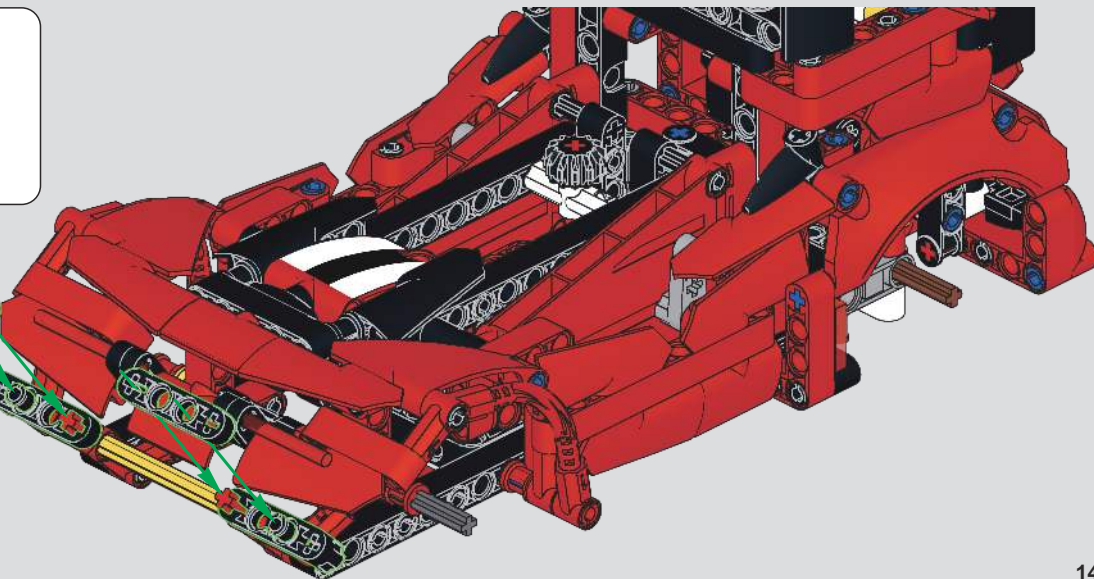

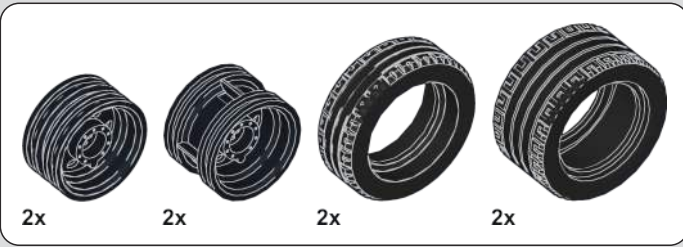

161

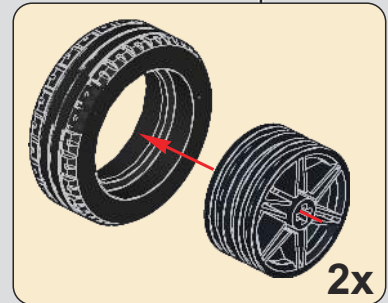
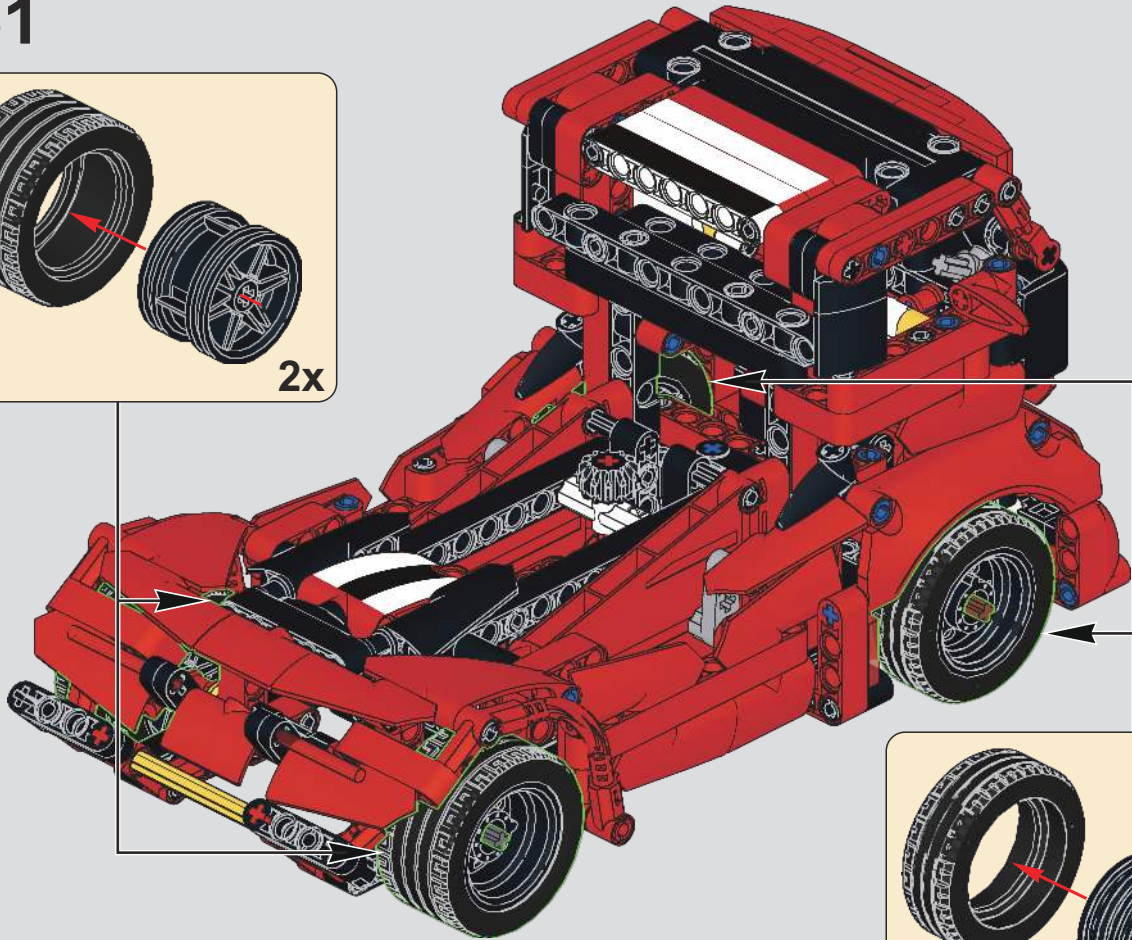
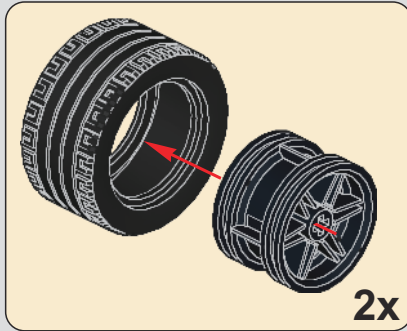

162

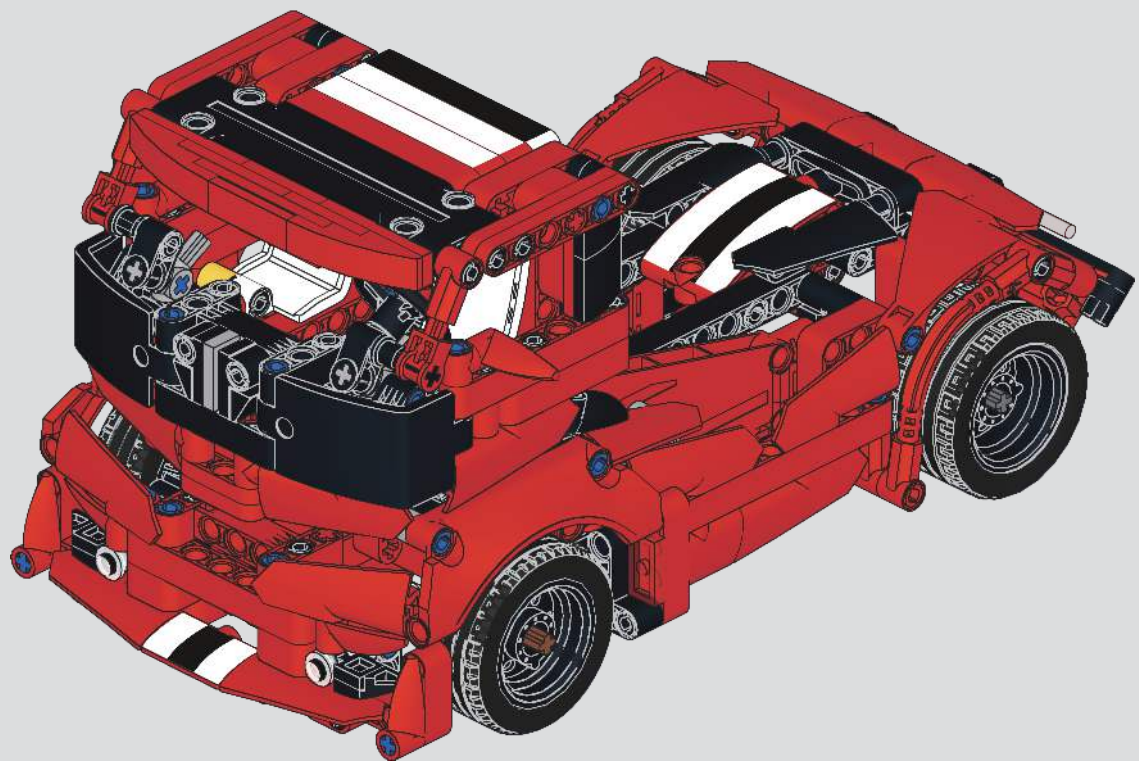

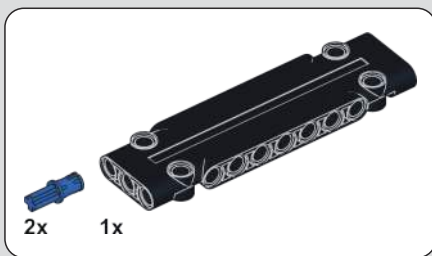
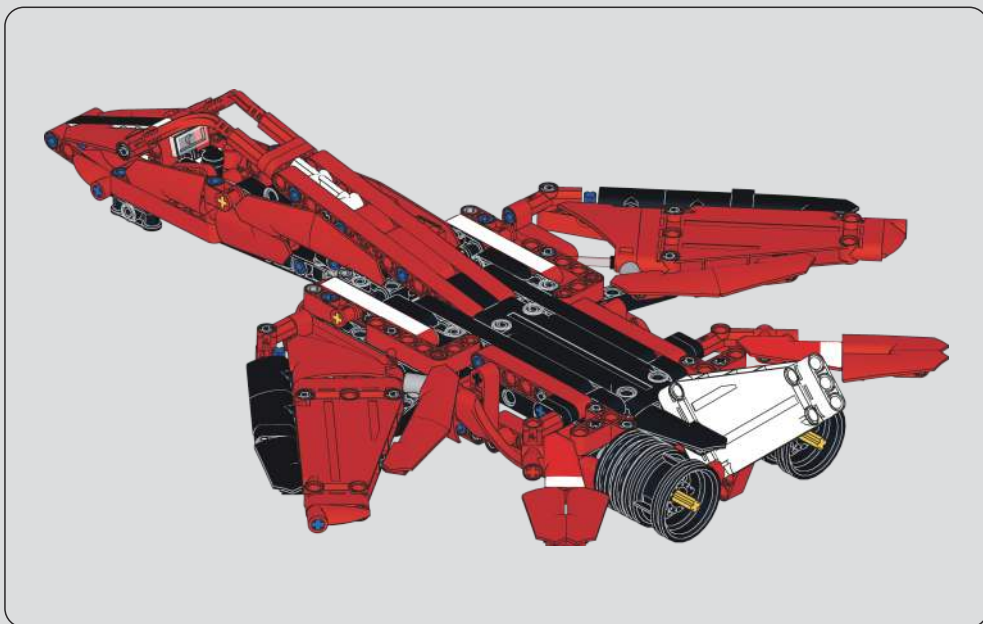

1



2

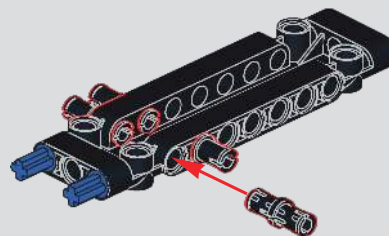
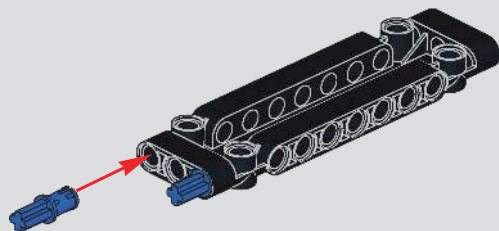

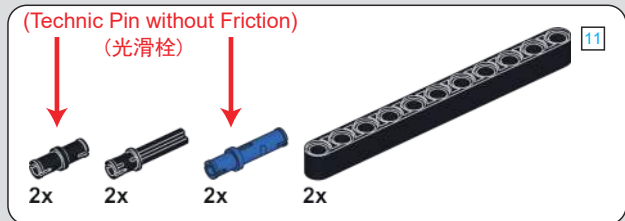

3

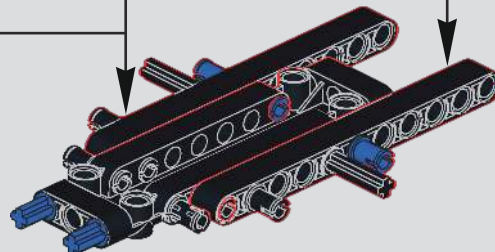
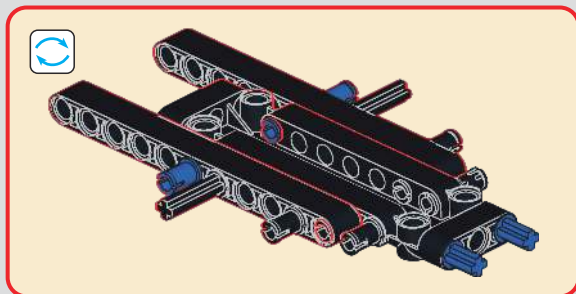
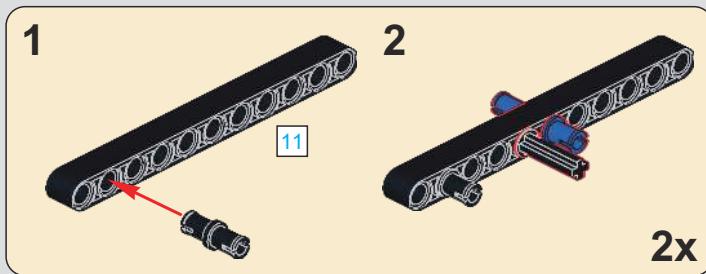

4

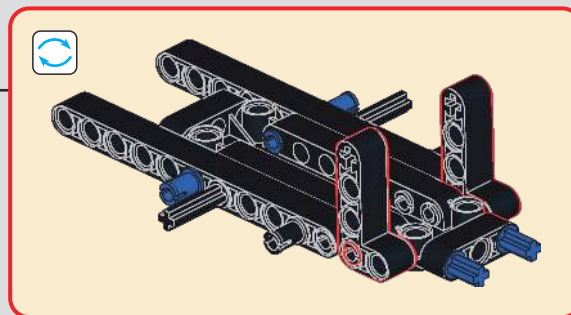
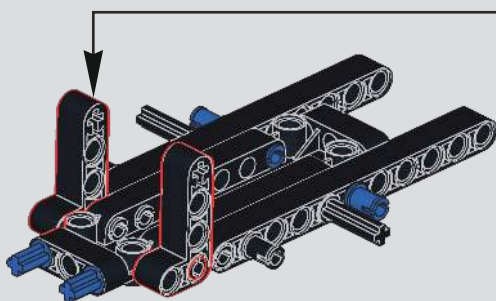

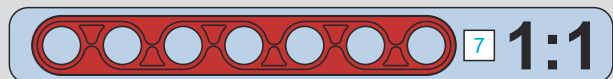

5

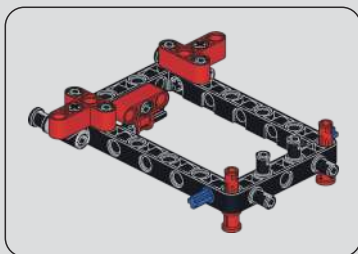
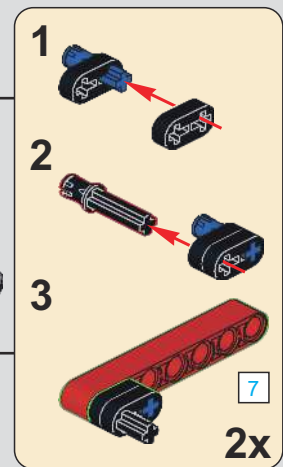
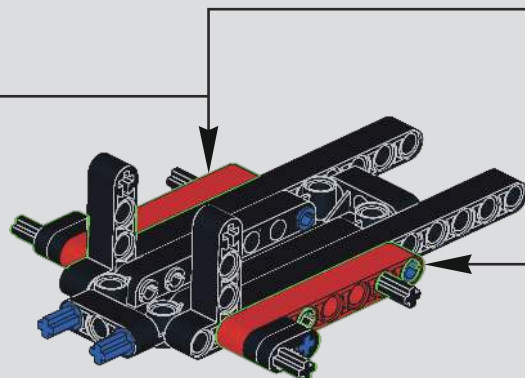
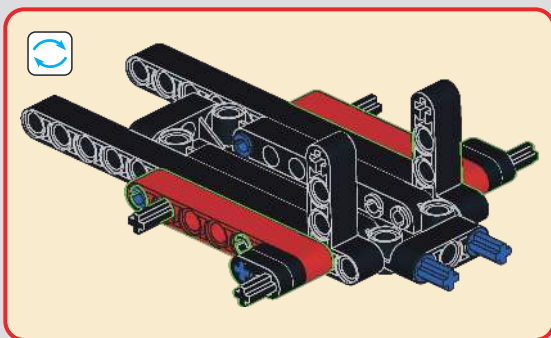

6

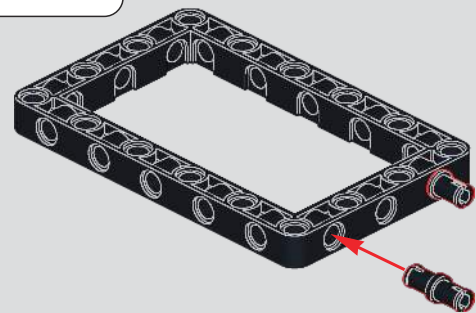



7

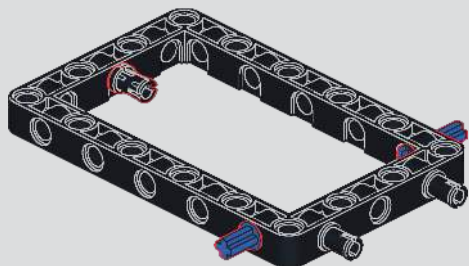

8

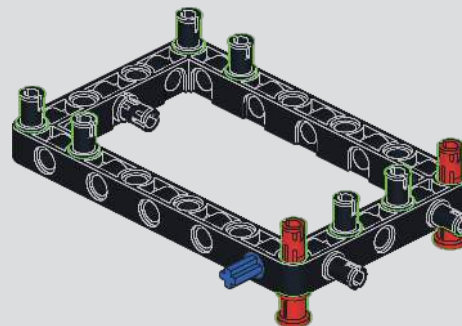

9

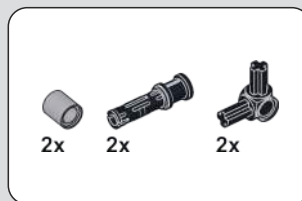
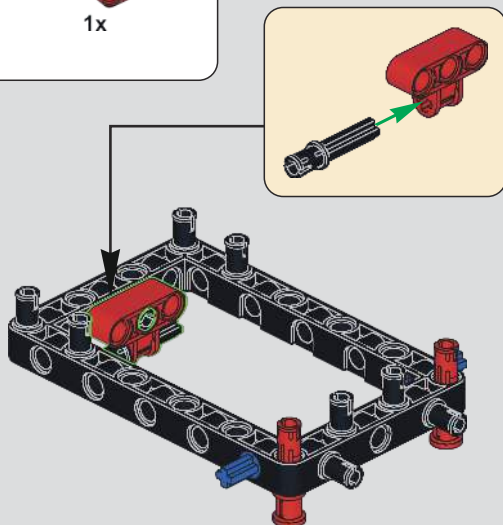

10

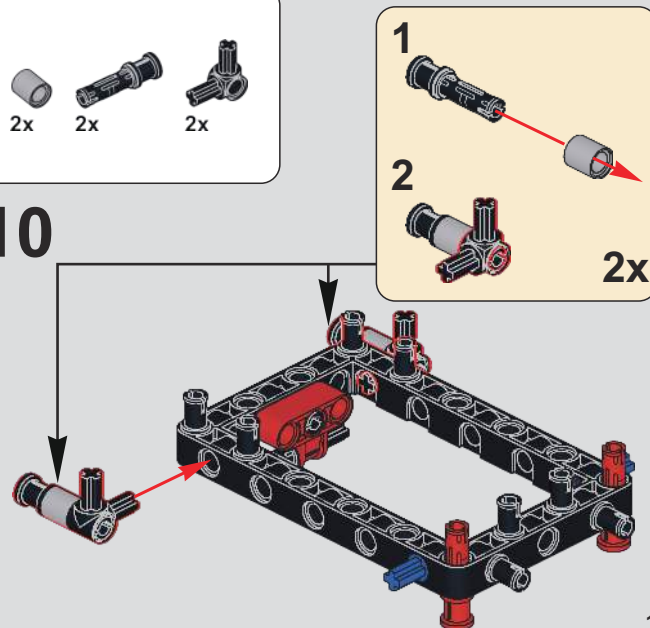

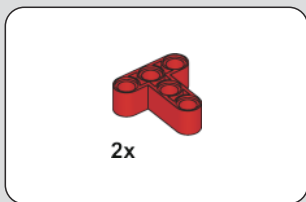

11

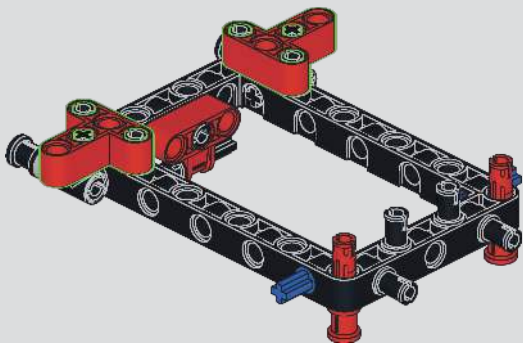

12

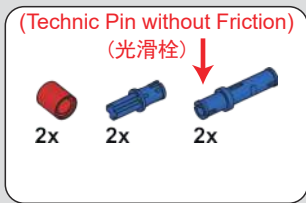
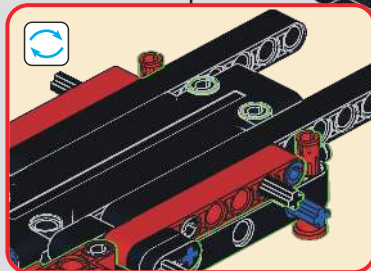
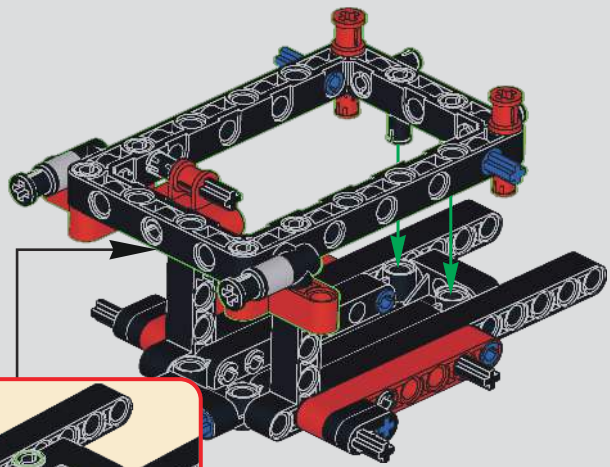

13

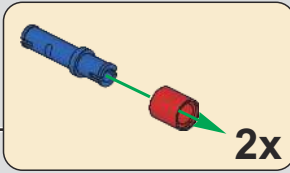
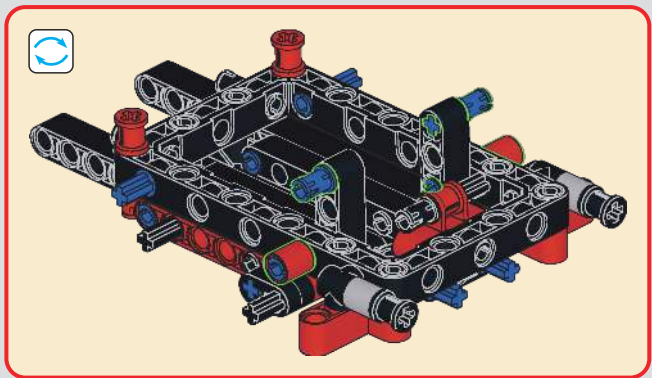
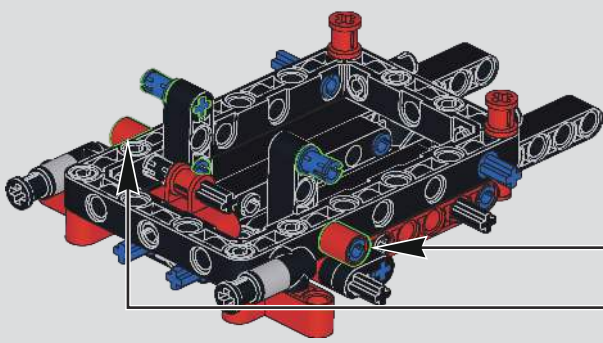

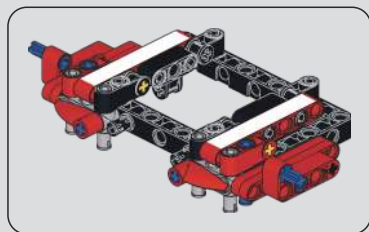

(Technic Pin without Friction)  
(光滑栓)



2x 1x

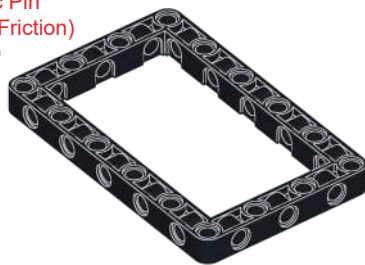

14

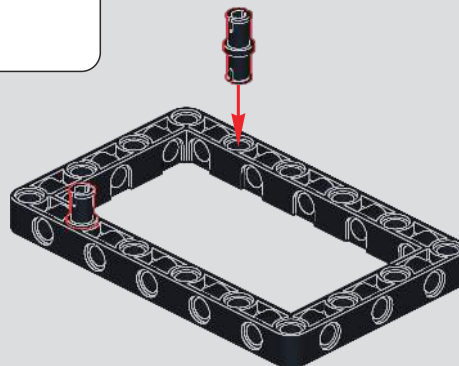

(Technic Pin without Friction)  
(光滑栓)



4x 2x

15

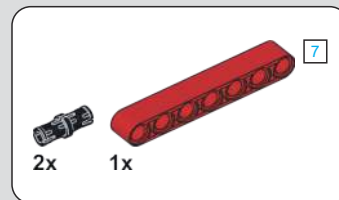
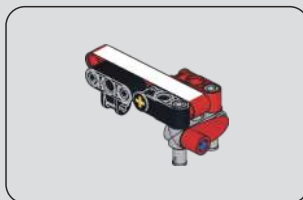
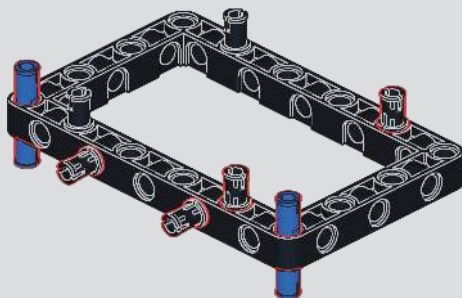

2x 1x

16

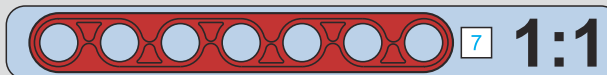
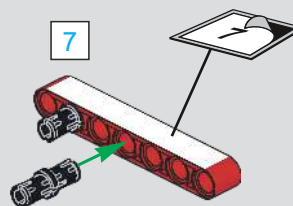



1x

# 17

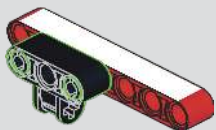

1x

1x

3

1x

1x

1x

1x

# 18

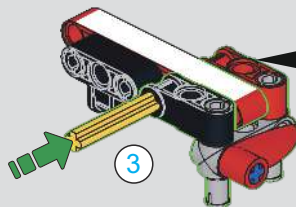

3

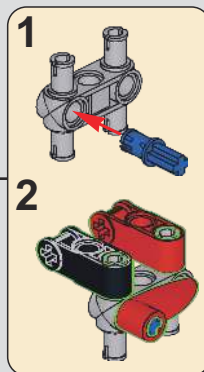

1

2

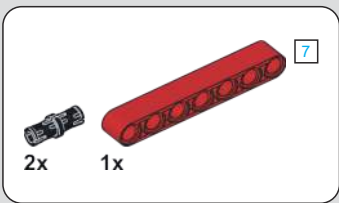
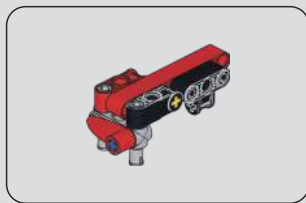

2x

1x

7

# 19

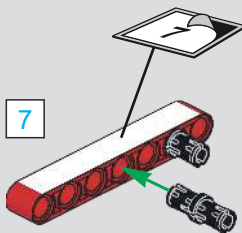

7

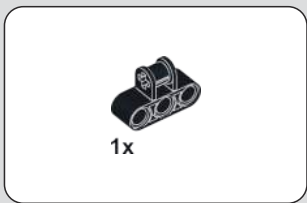

1x

# 20

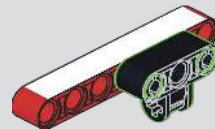

7

3

1:1

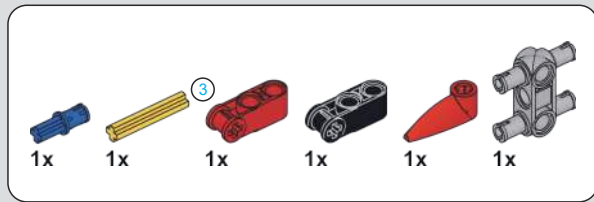

21

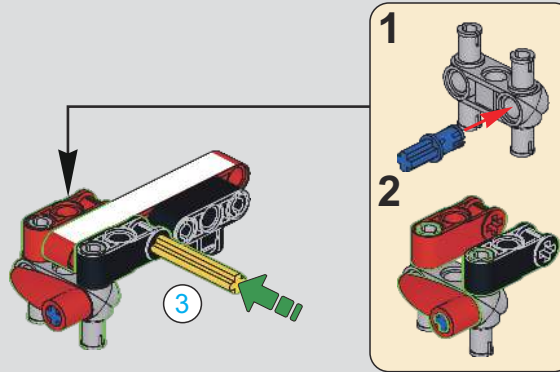

22

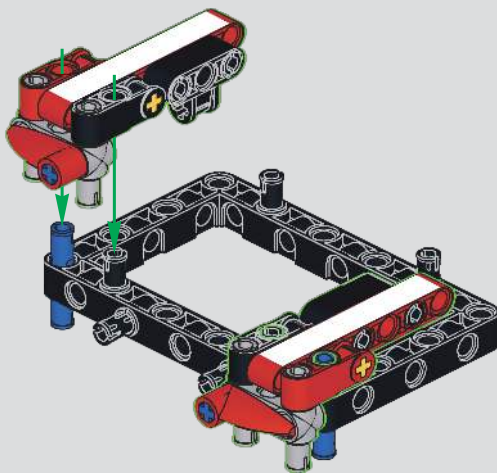

23

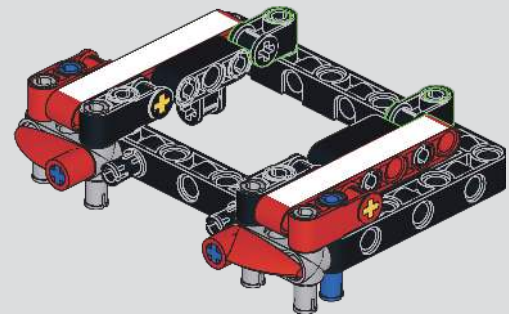

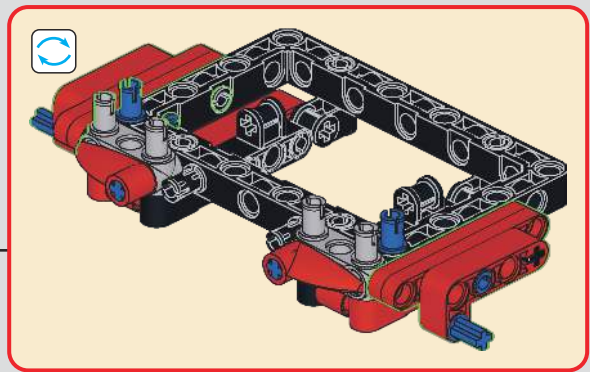

# 24

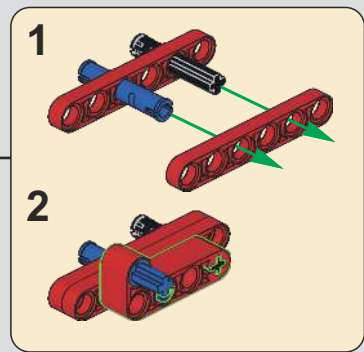
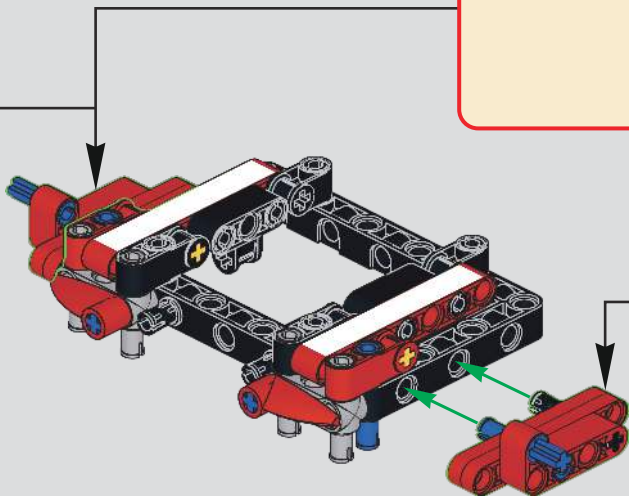
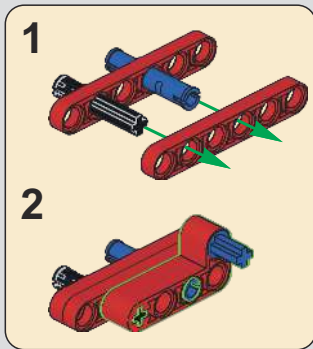

# 25

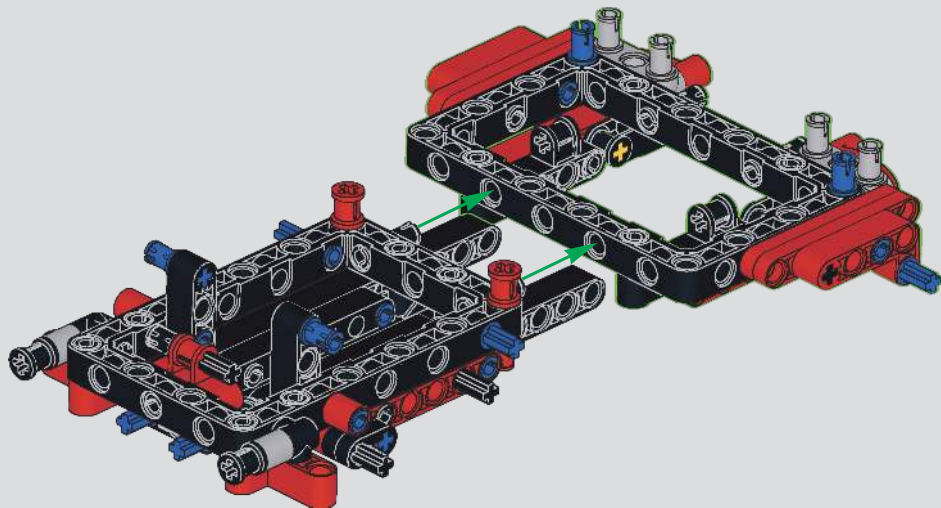

(Technic Pin without Friction)  
(光滑栓)

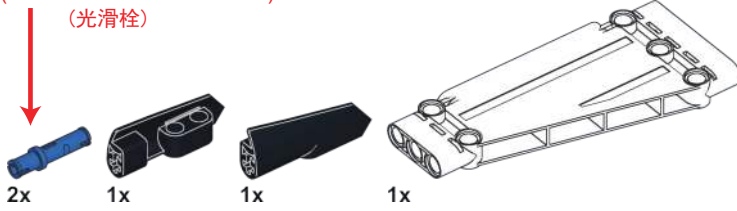

26

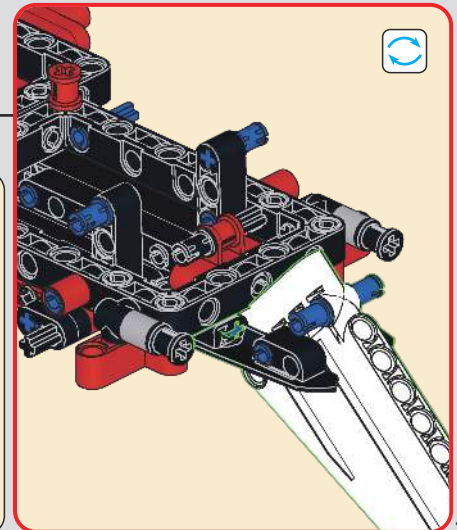
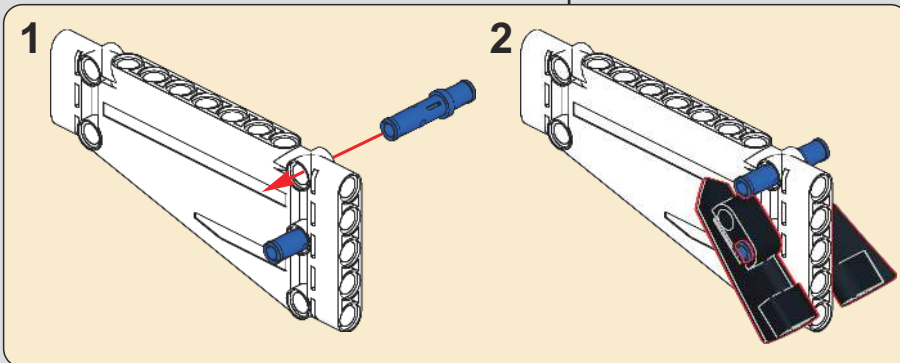
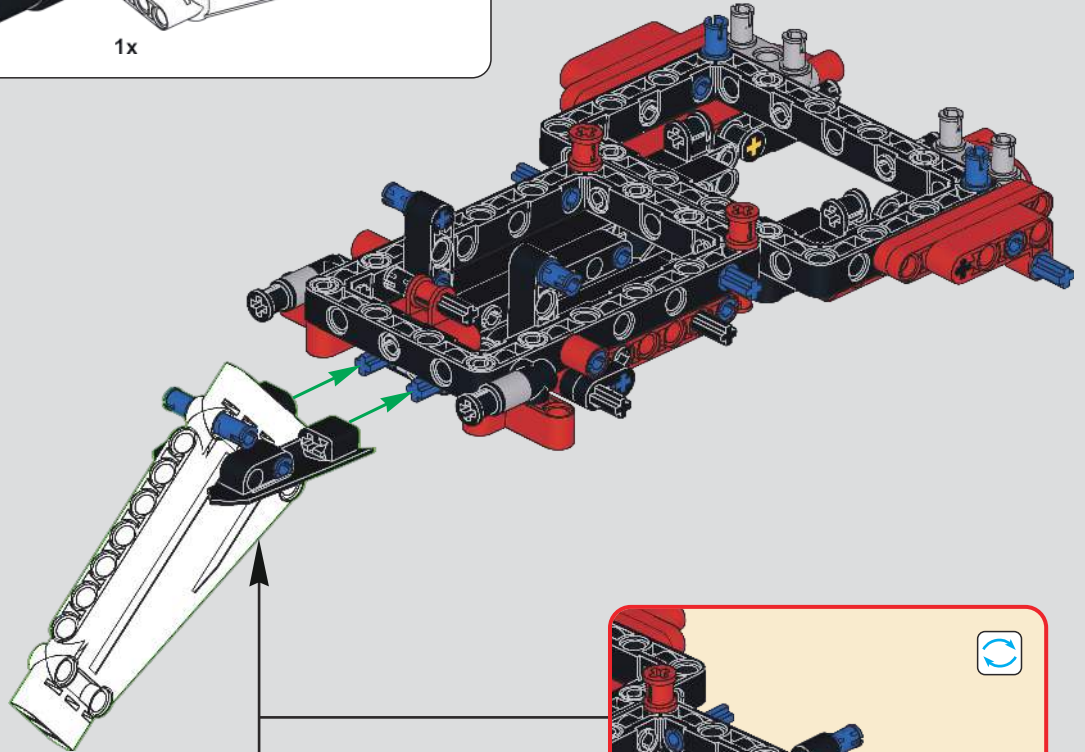

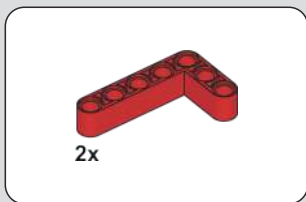

27

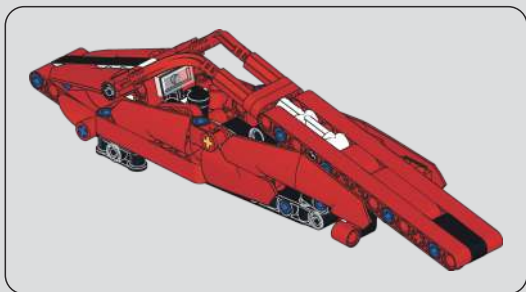
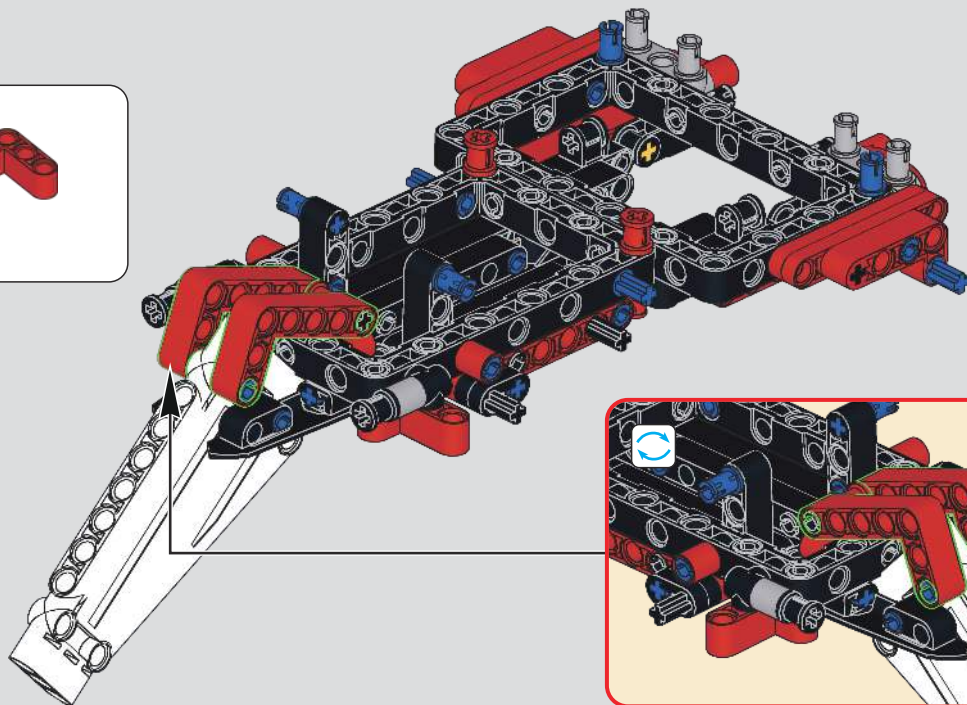

28



29

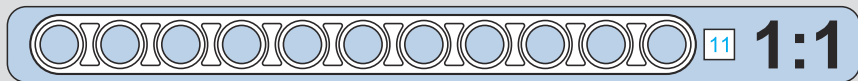
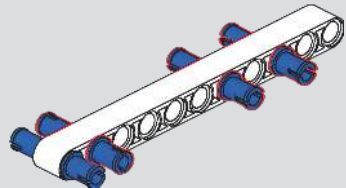
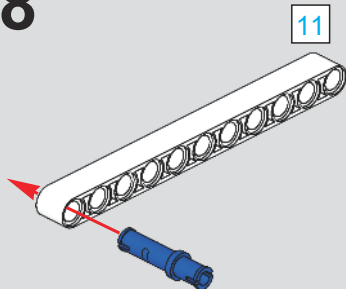

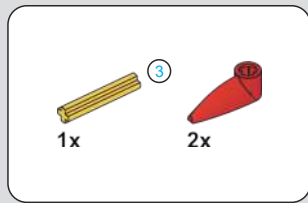

30

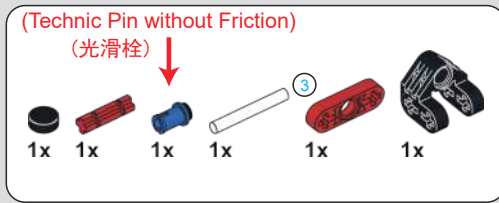
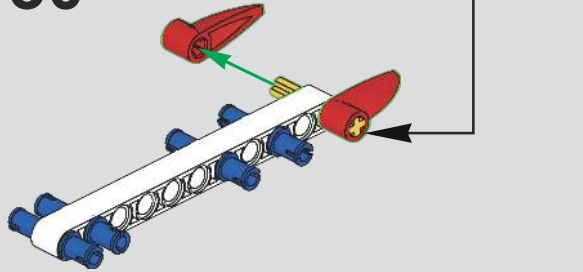

31

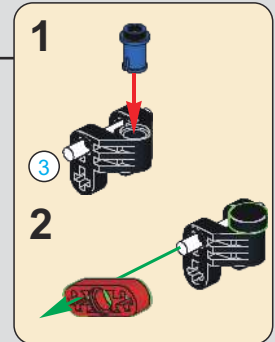
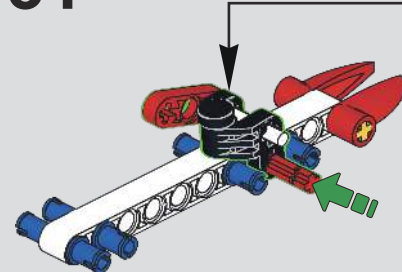

32

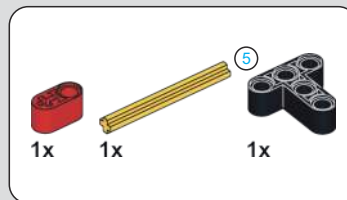
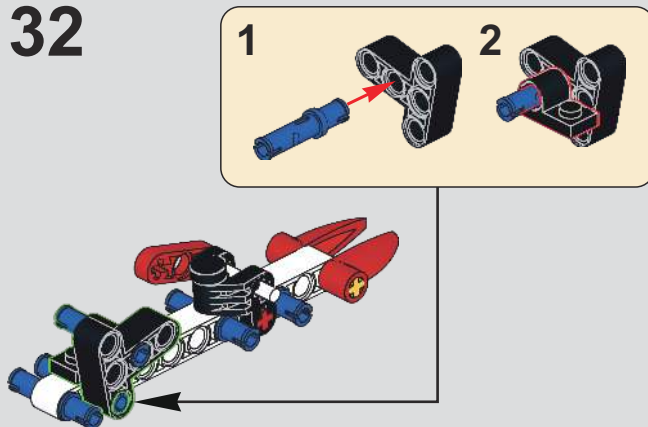

33

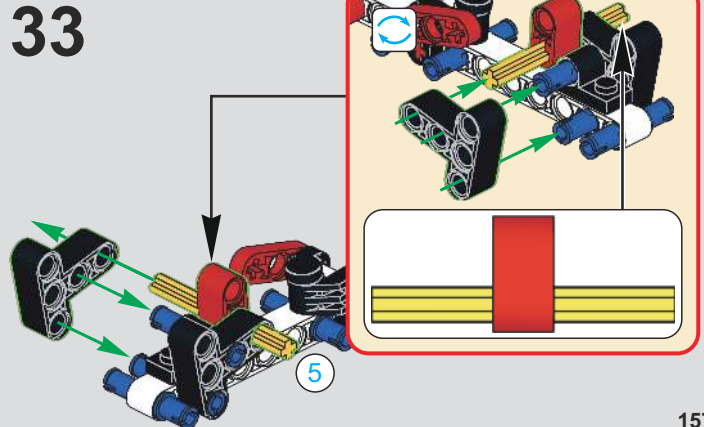

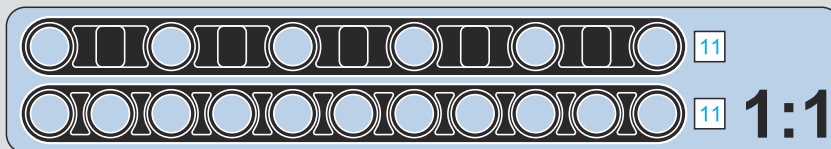
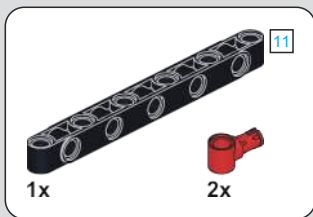

34

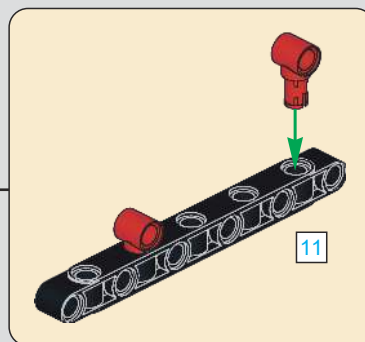
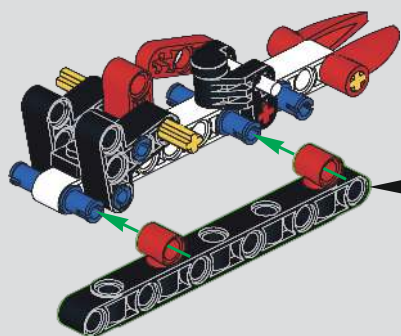

35

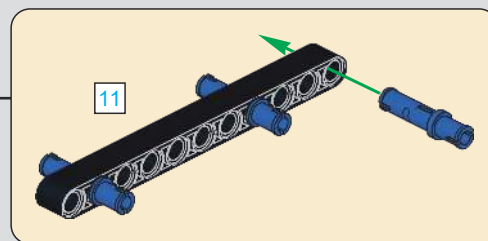
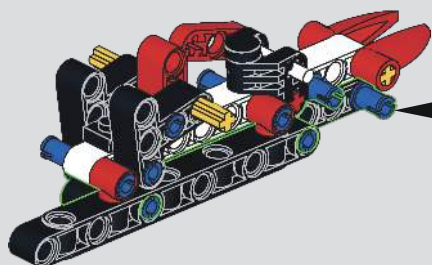
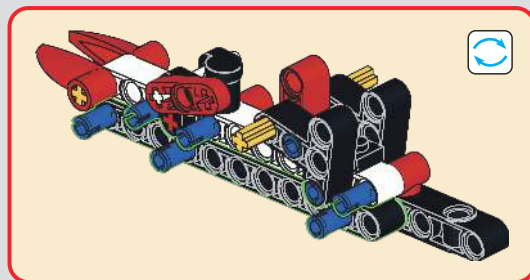

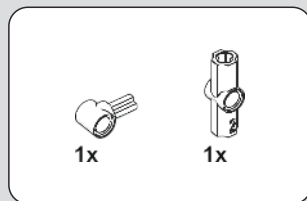
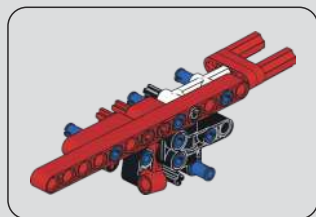

36

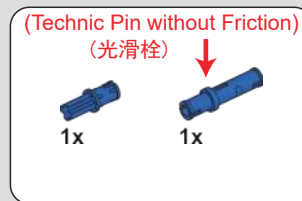

37

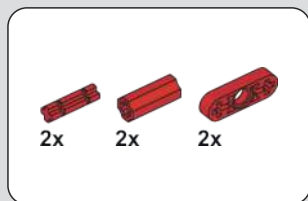
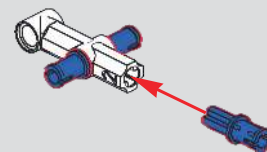
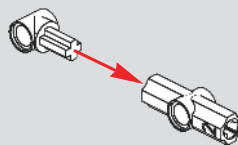

38

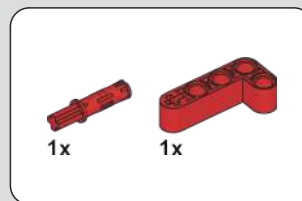
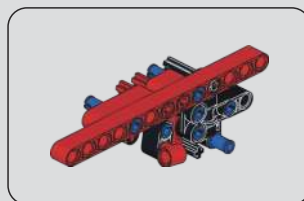
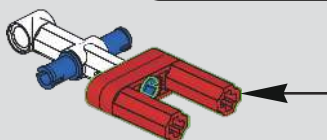
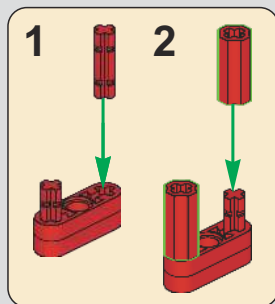

39

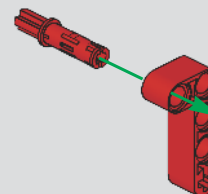

(Technic Pin without Friction)

(光滑栓)



1x

3x

40

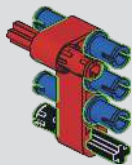

(Technic Pin without Friction)

(光滑栓)



1x

1x

2x

1x

1x

41

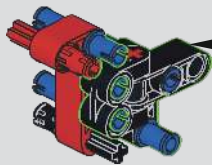

1

2

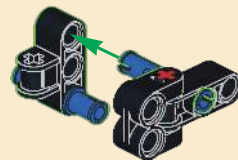

13

1:1

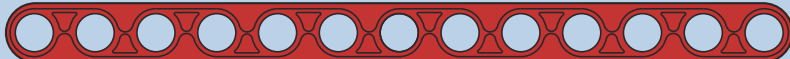

1x

1x

1x



42

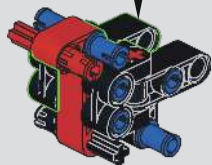
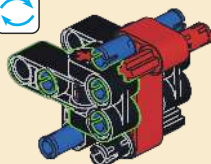
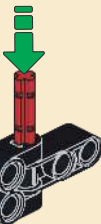

13

1x

1x



43

13

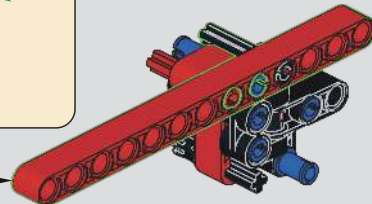
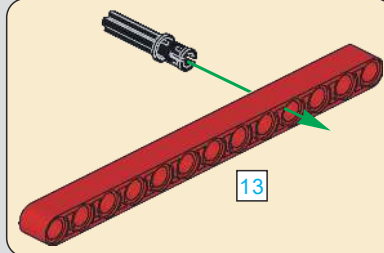



44

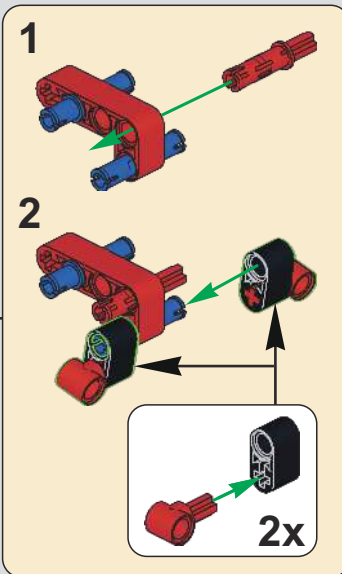
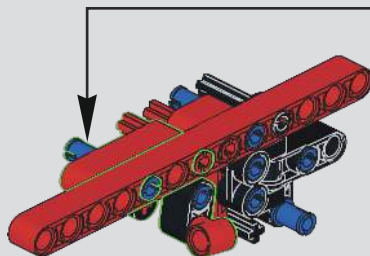

45

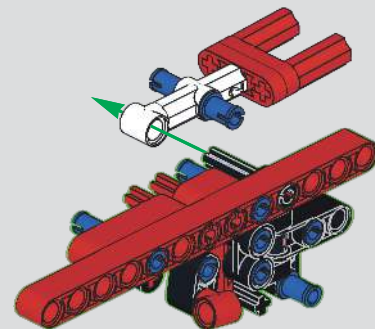

46

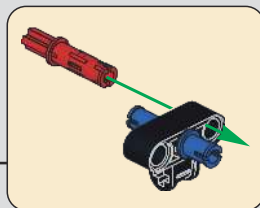
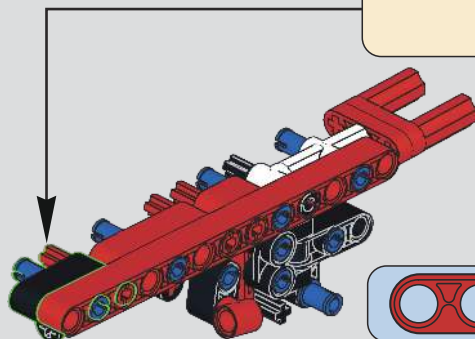

47

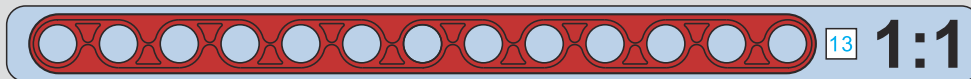
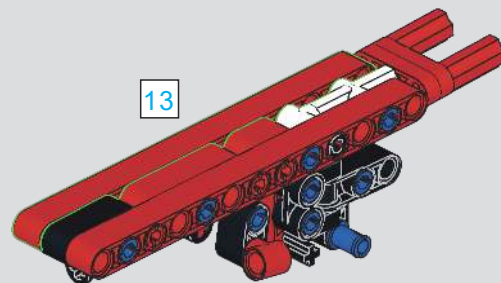

48

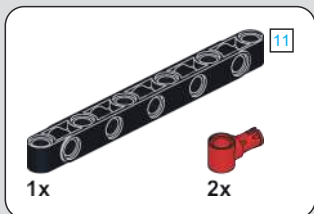
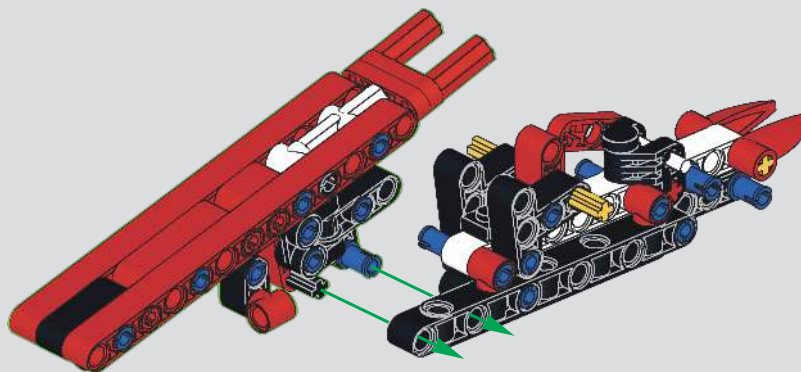

49

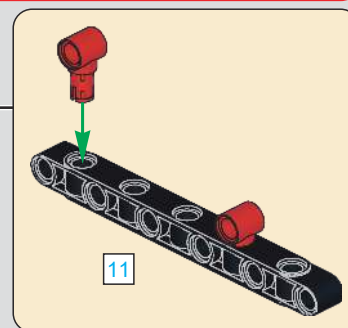
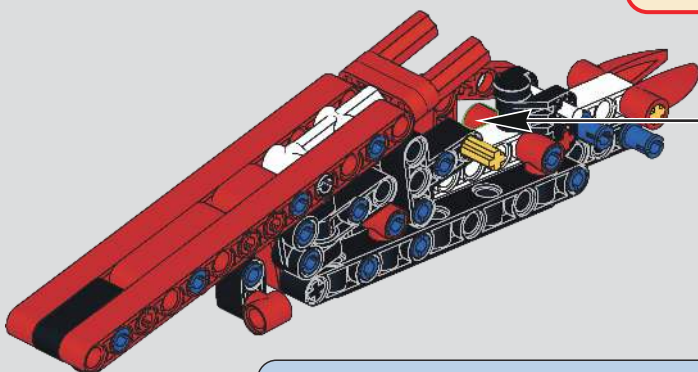
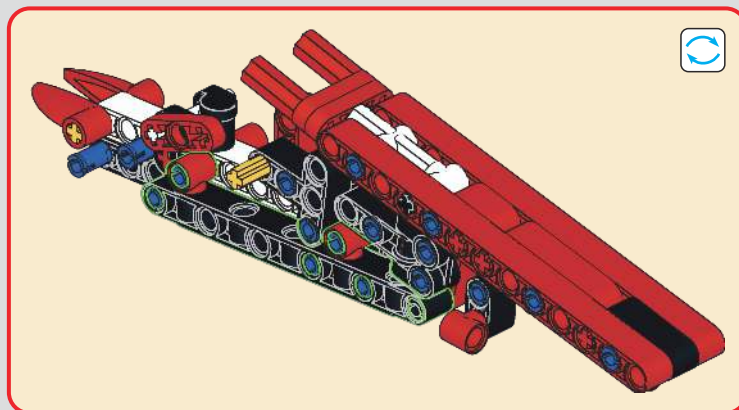

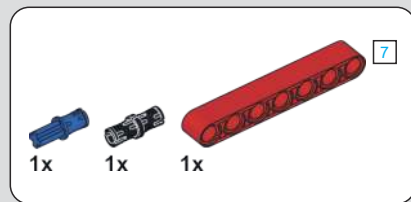

50

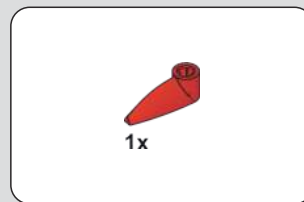

51

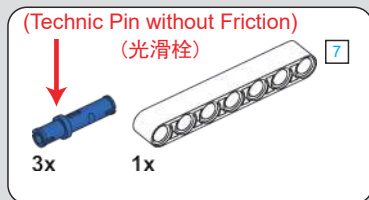
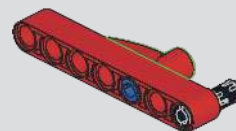
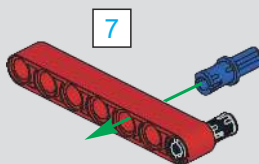

52

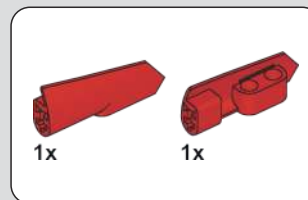

53

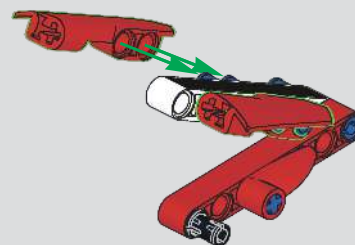
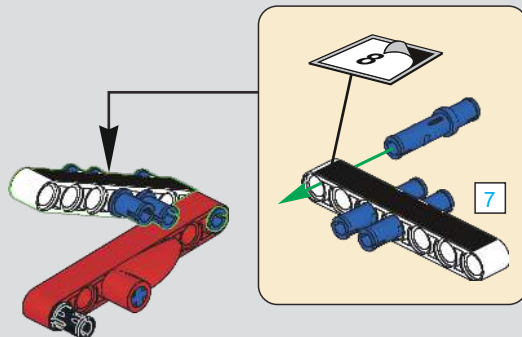

# 54

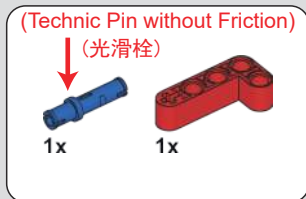
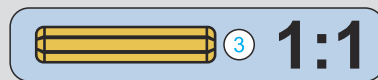
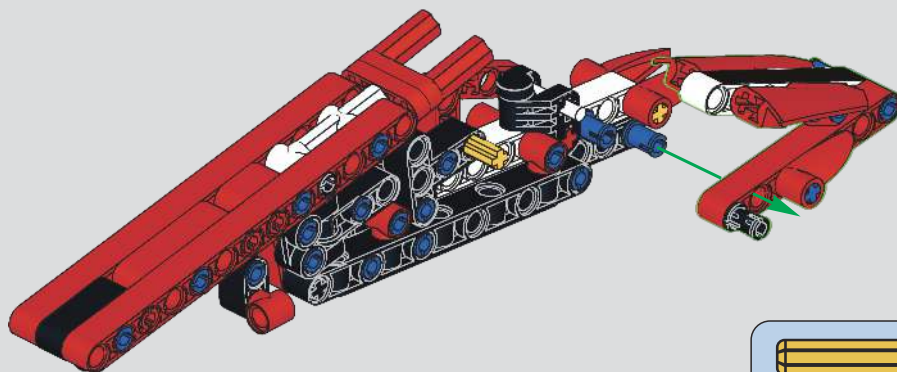

55



56

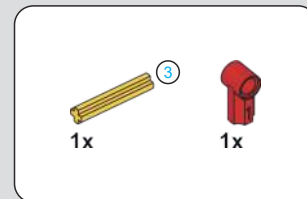

57

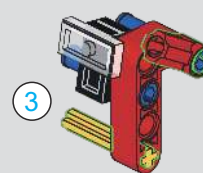
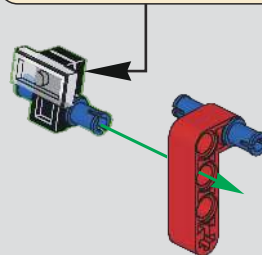
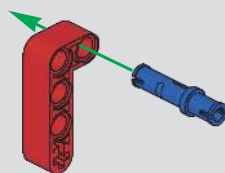
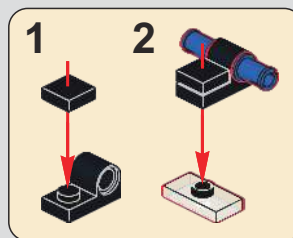

# 58

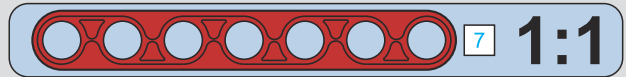
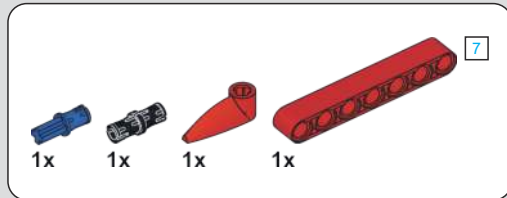
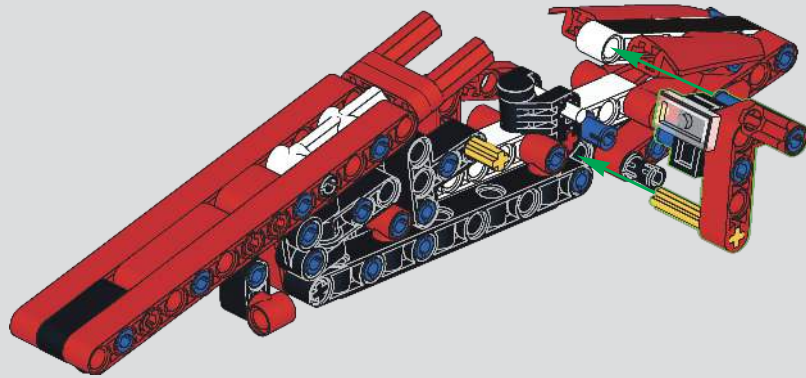

# 59

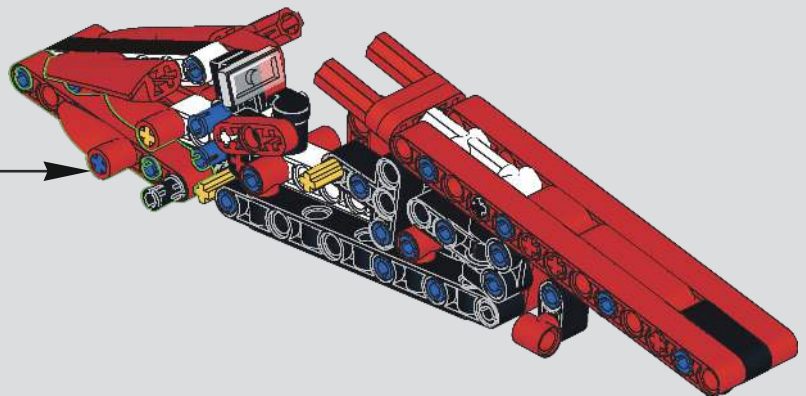
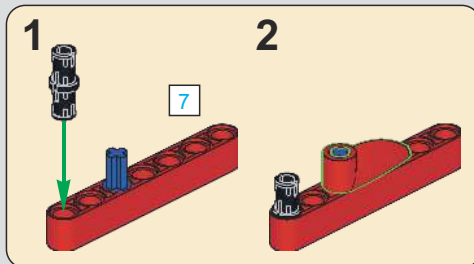

(Technic Pin without Friction)

(光滑栓)



60

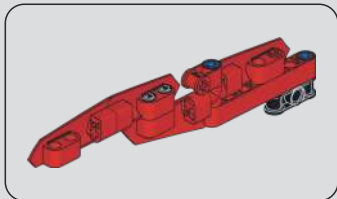
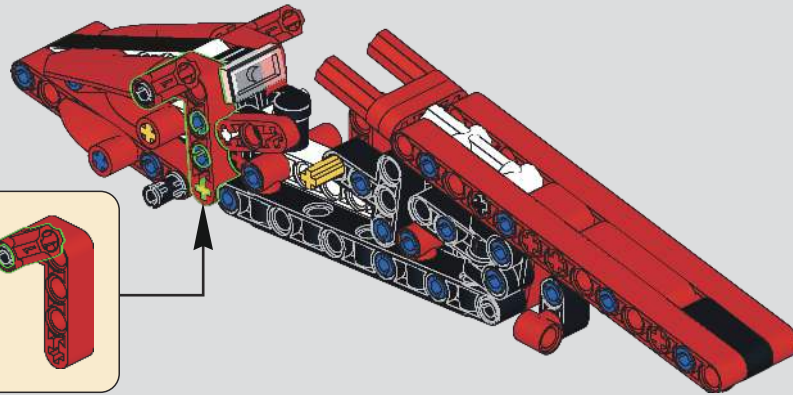
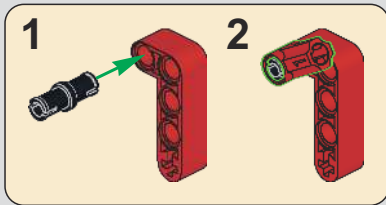

(Technic Pin without Friction)

(光滑栓)



61

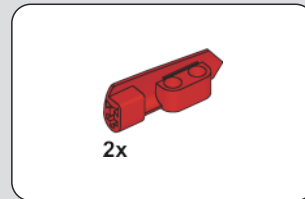
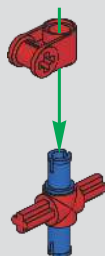

62

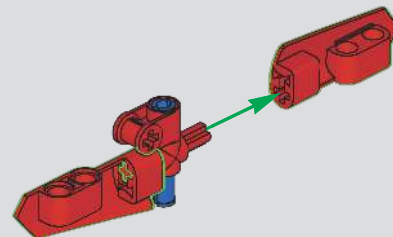

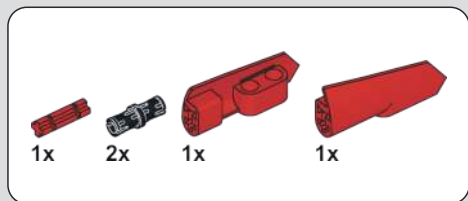

63

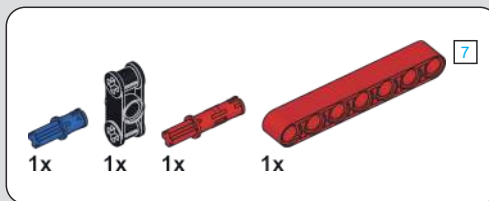
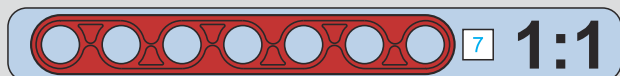
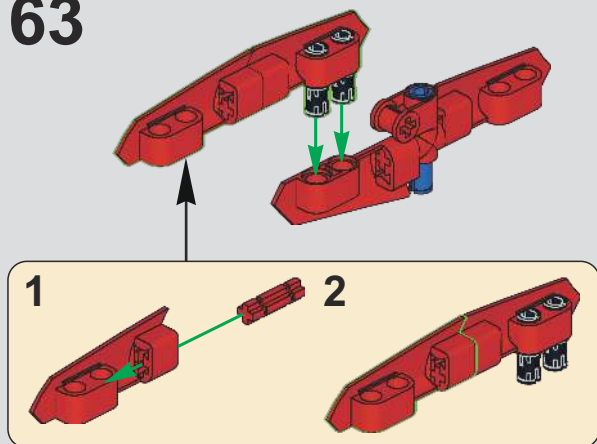

64

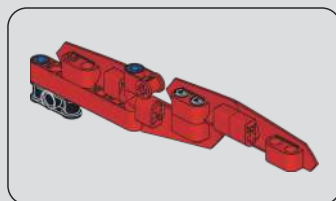
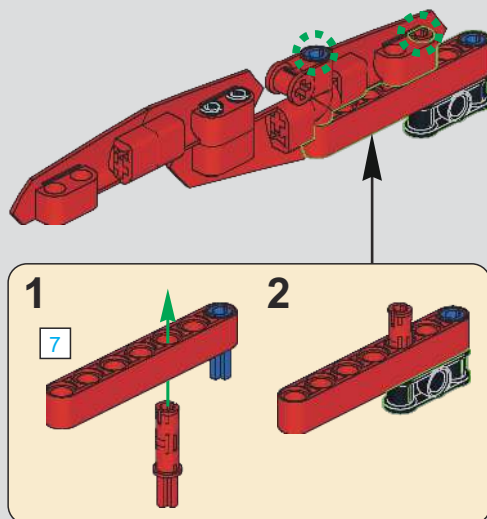

65

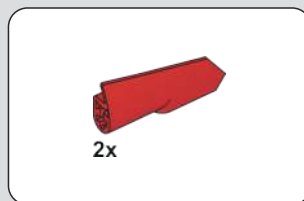
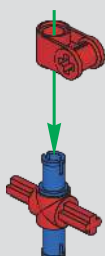

66

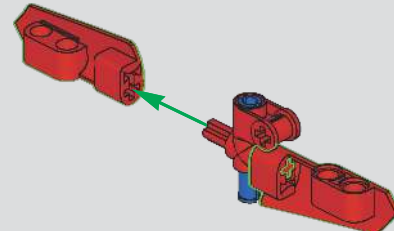

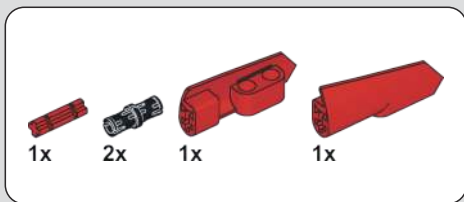

67

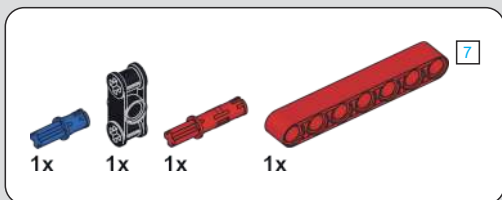
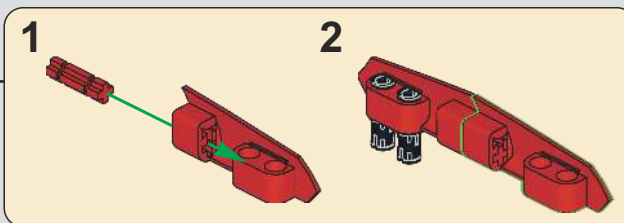
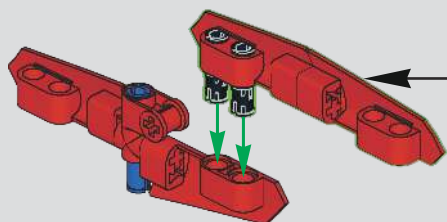

68

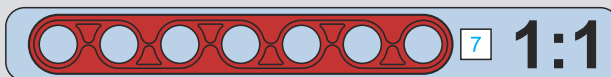
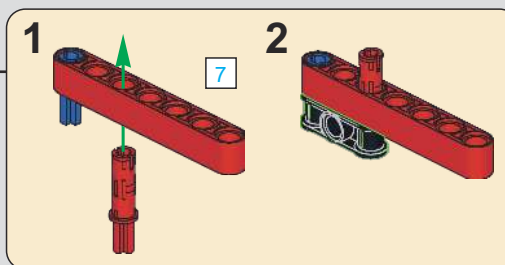
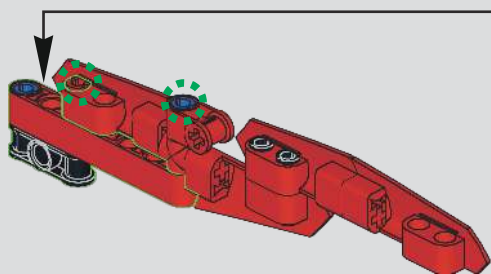

69

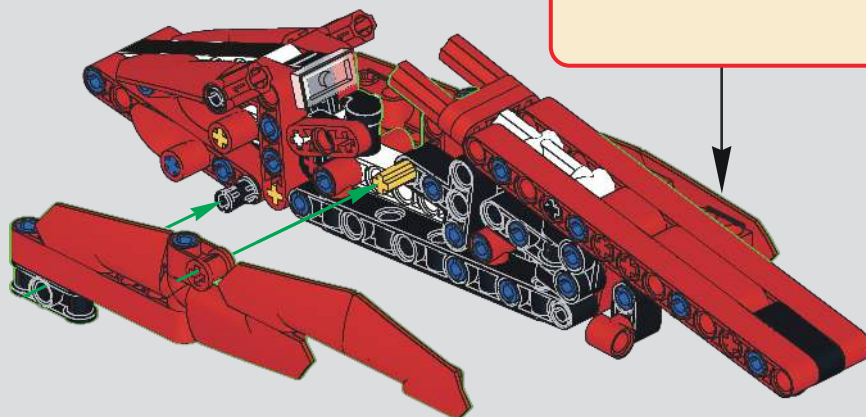
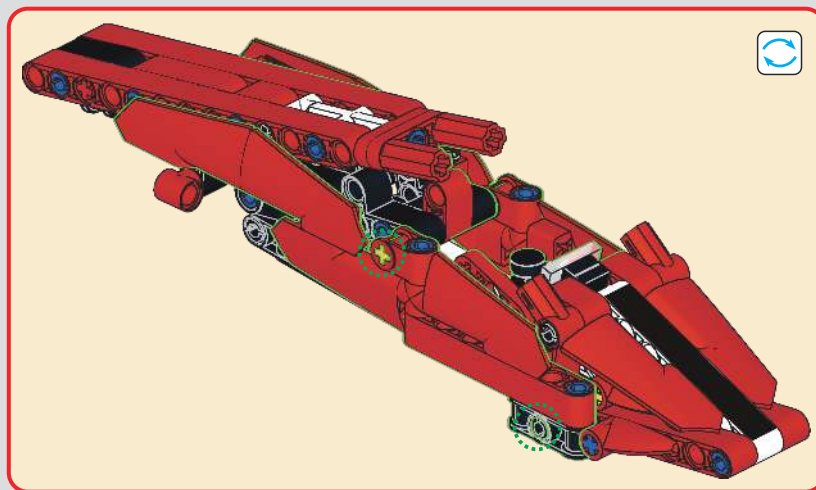

70

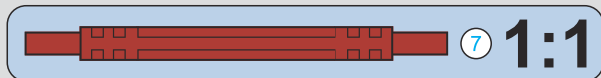
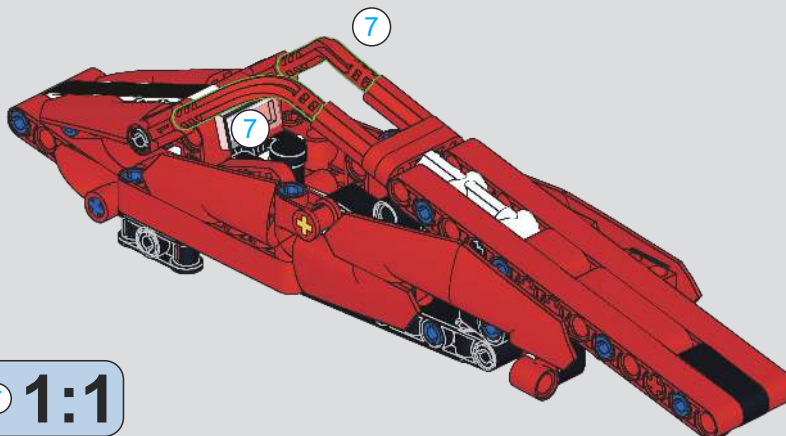

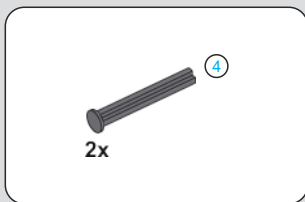

71

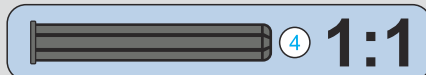
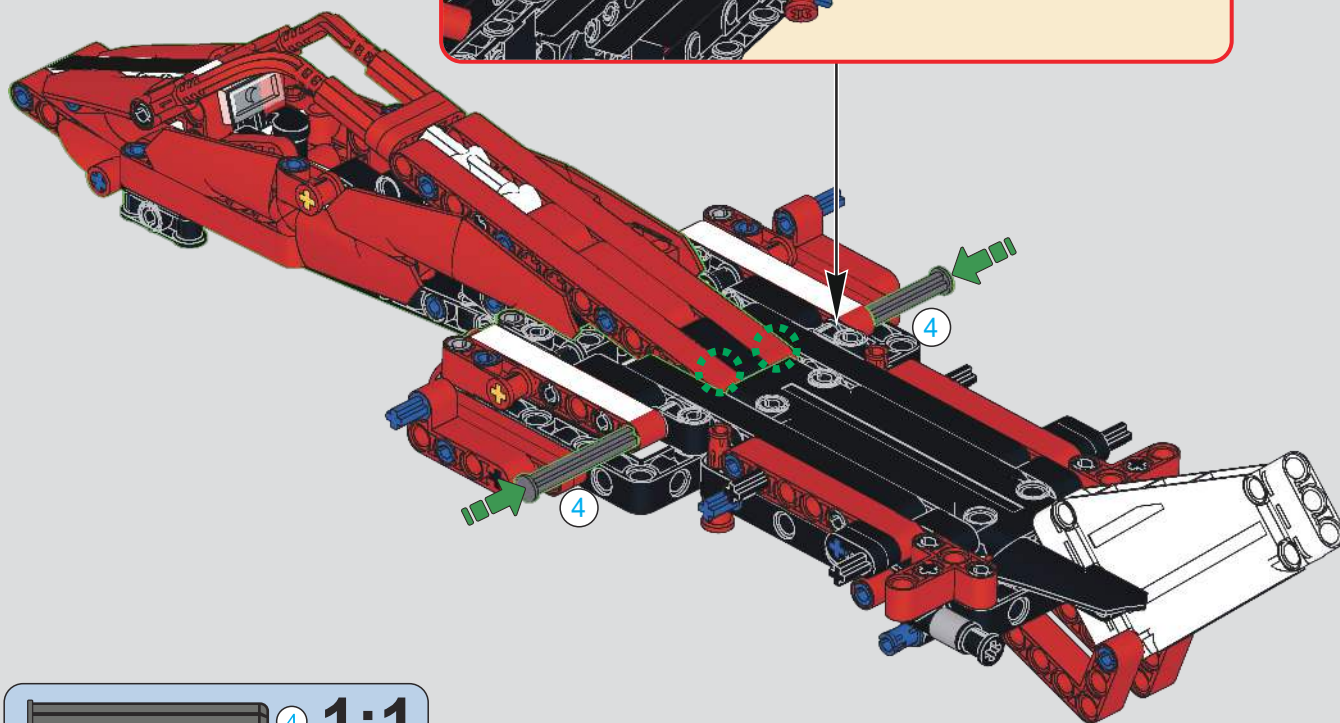
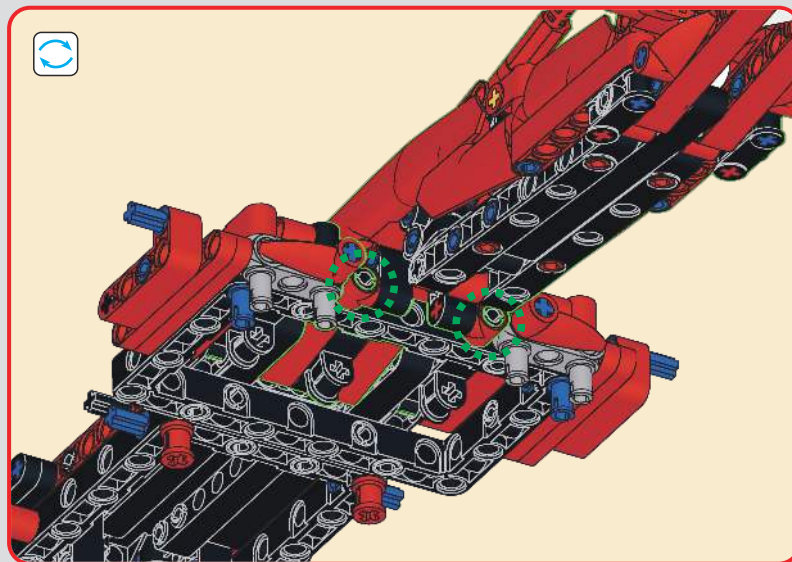

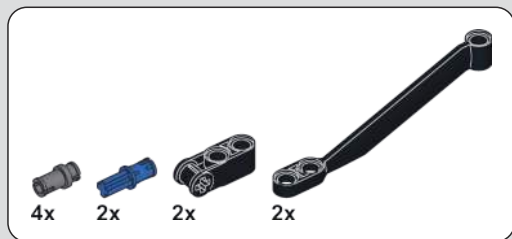

# 72

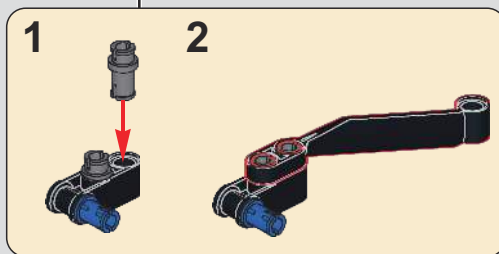
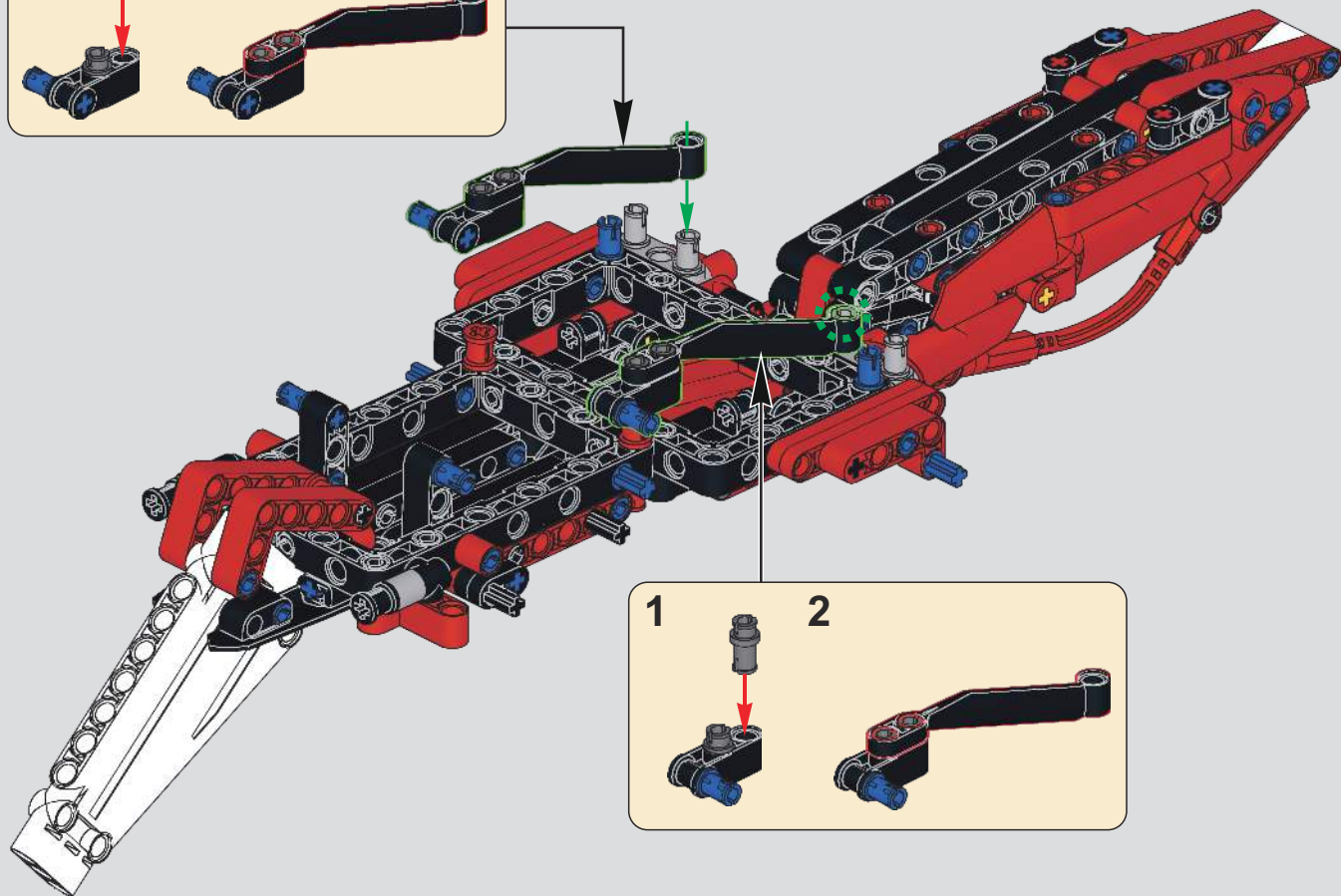
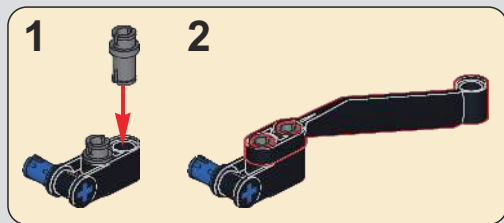

(Technic Pin without Friction)  
(光滑栓)



2x



4x



2x

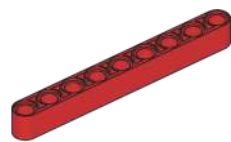

2x

9

# 73

1

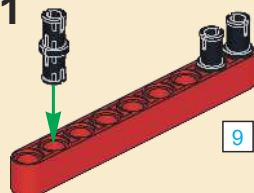

9

2

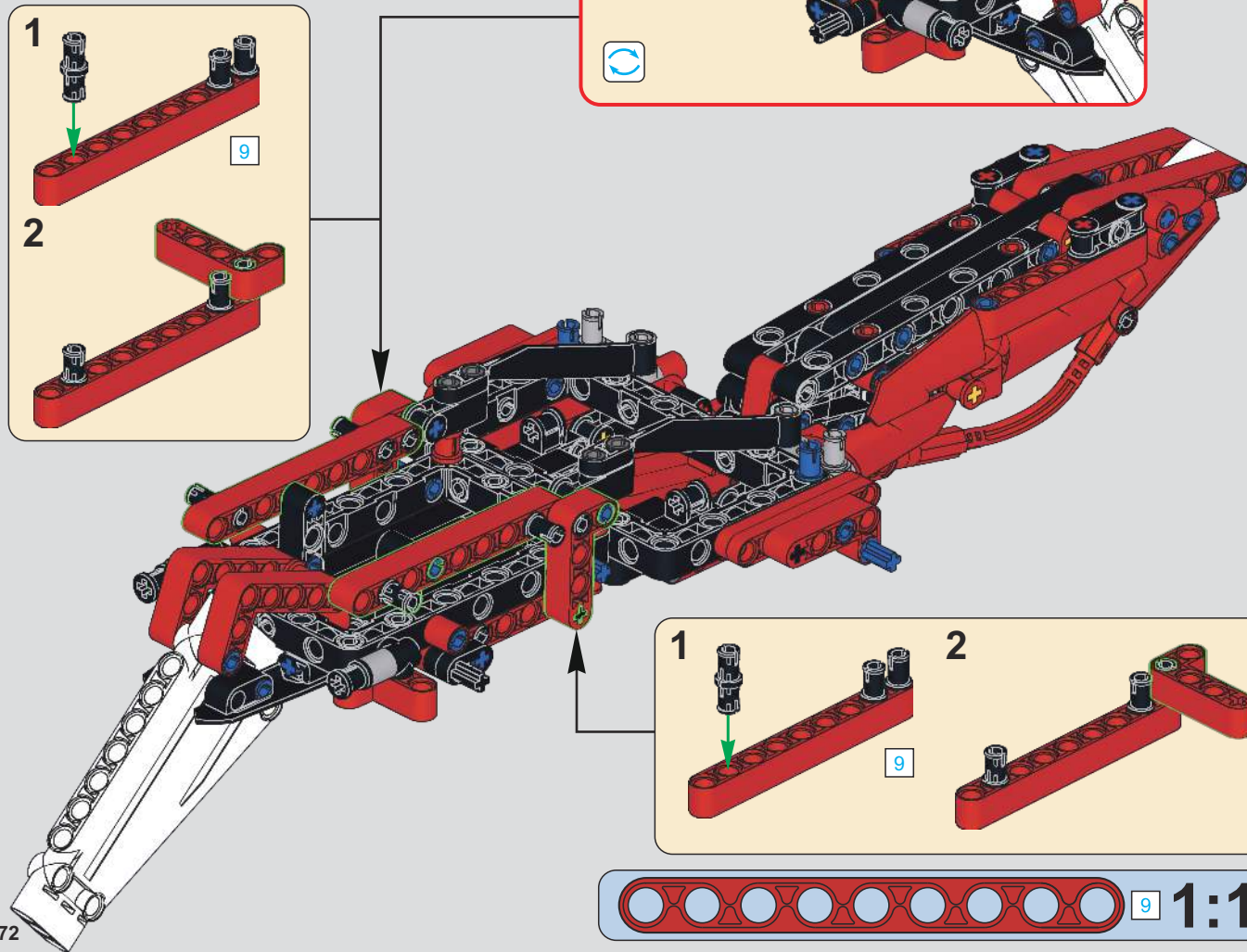
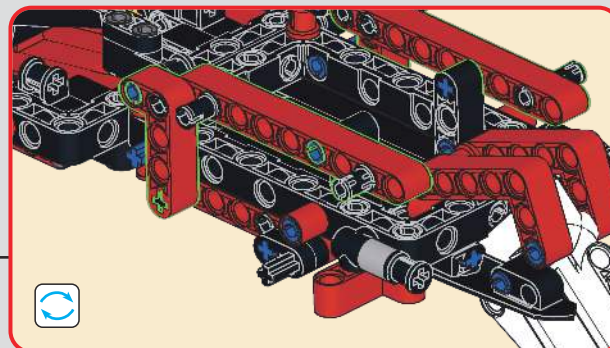
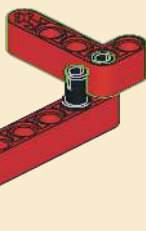

1

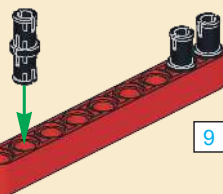

9

2

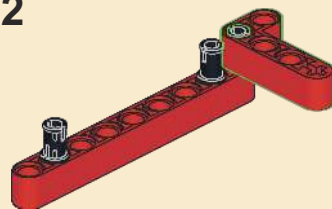

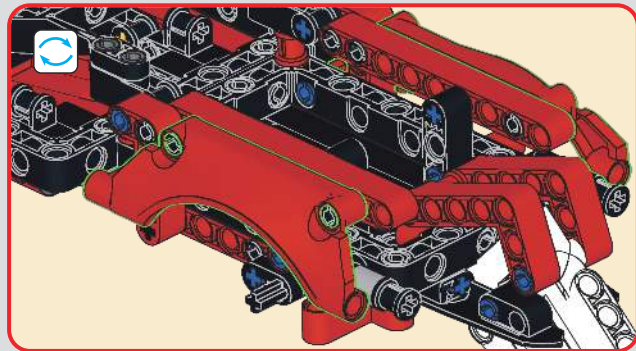
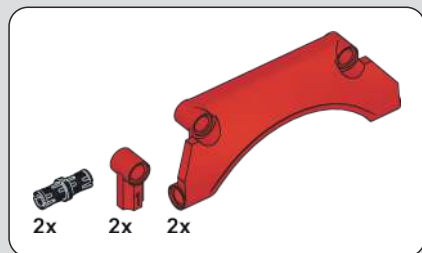

# 74

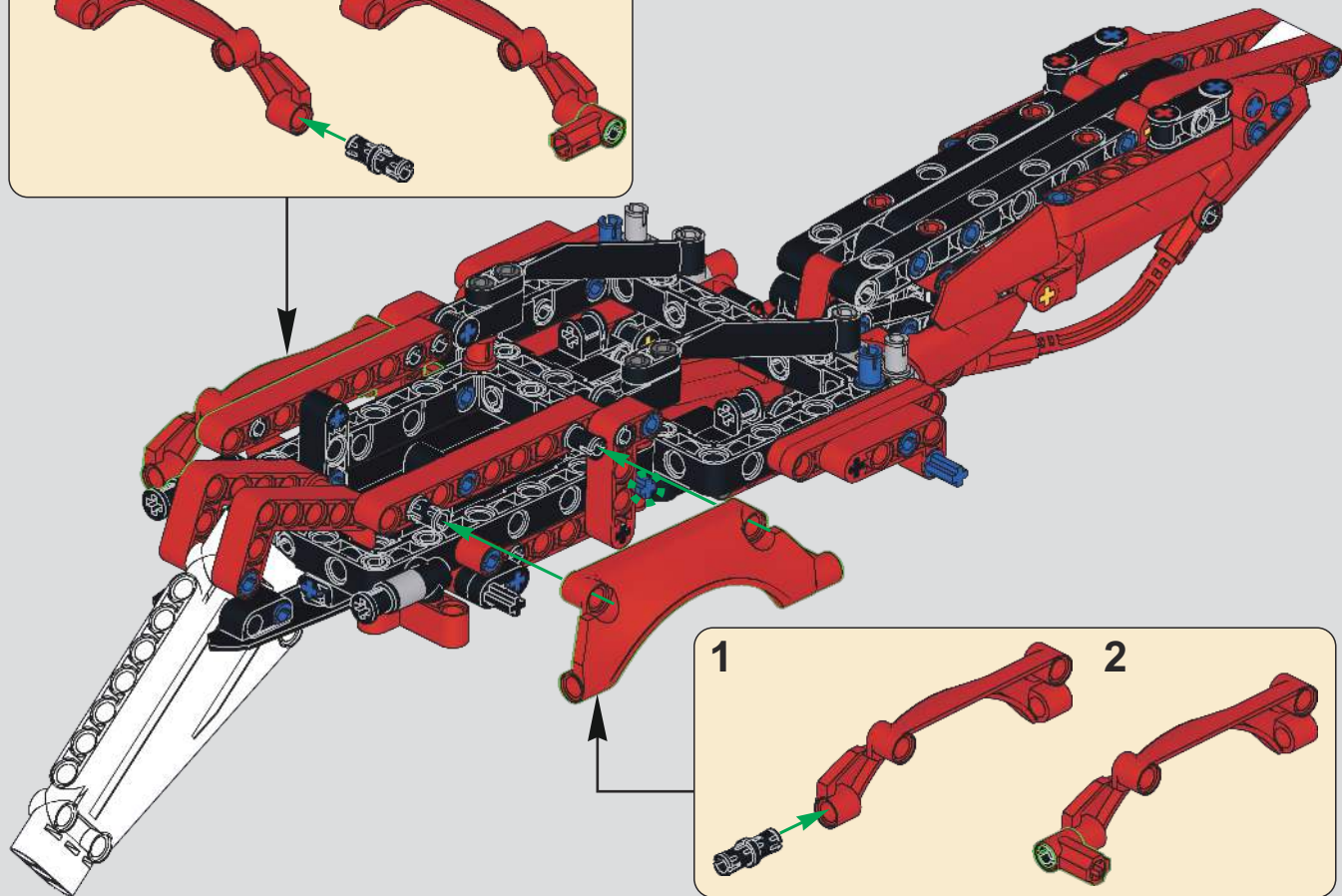
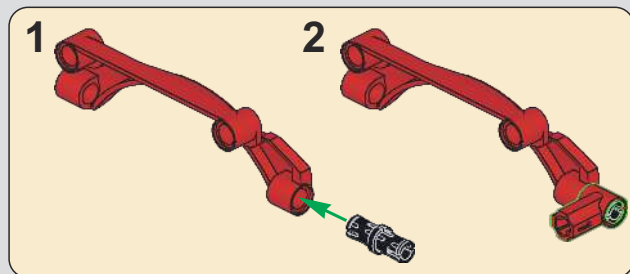

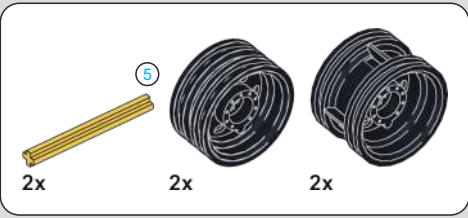

75

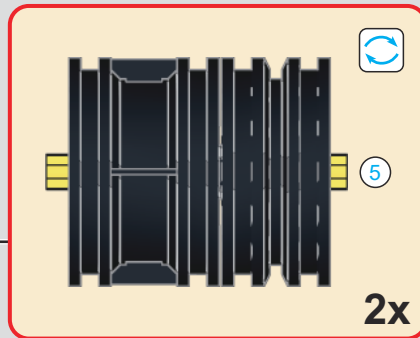
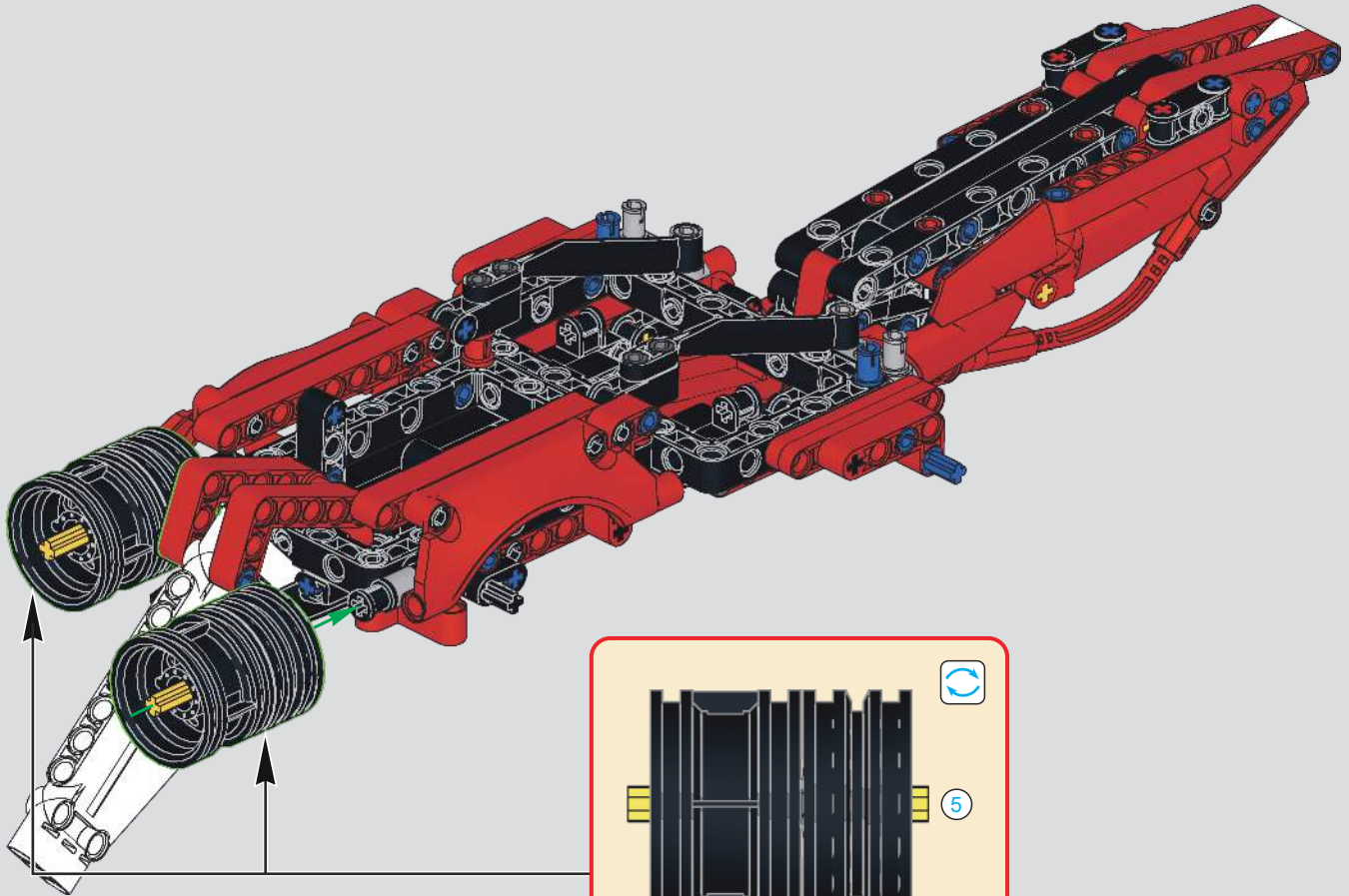

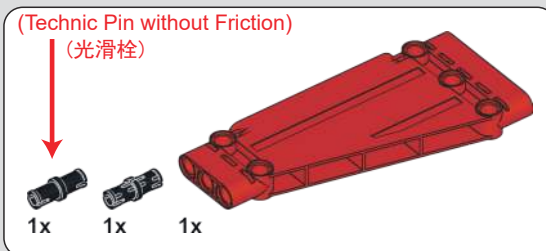
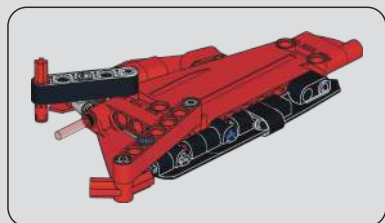

76

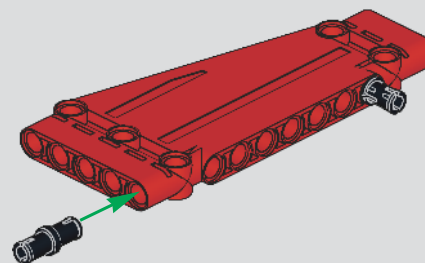
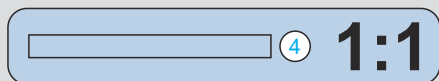

77

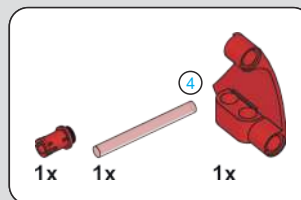

78

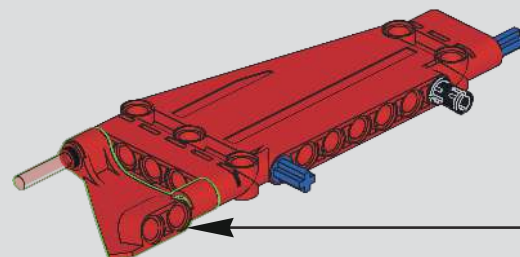
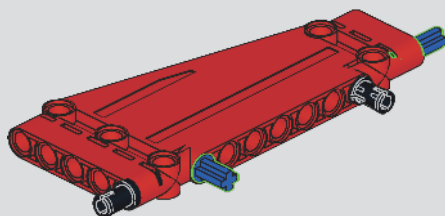
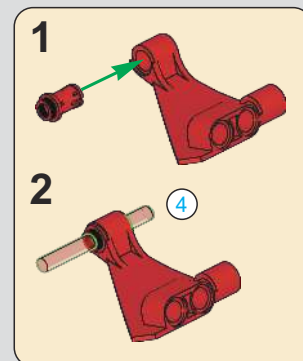

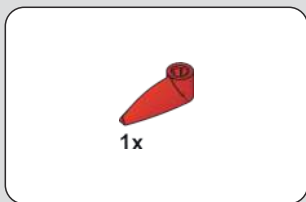

79

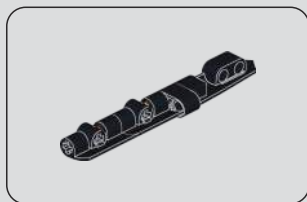

80

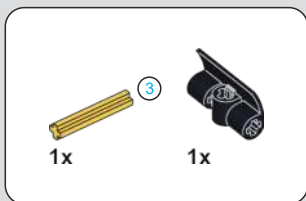
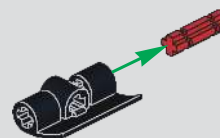
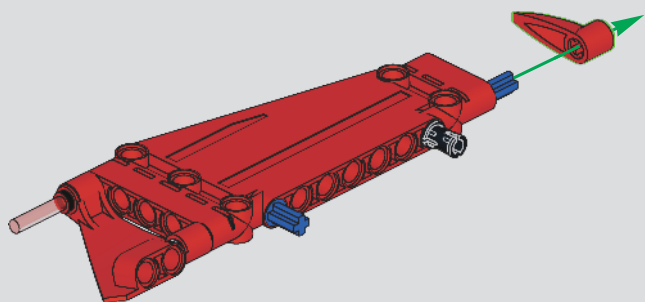

81



82

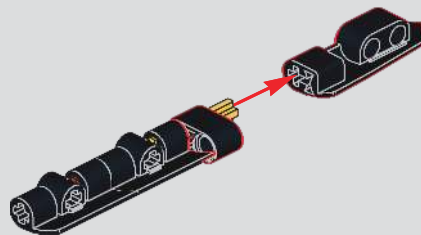
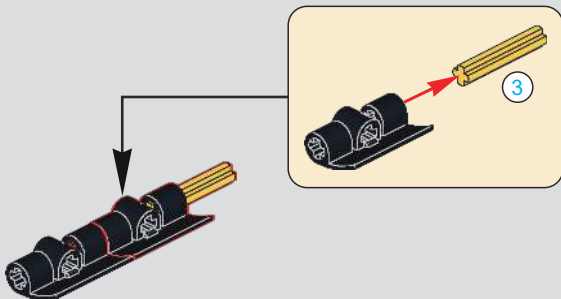

# 83

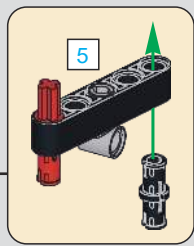
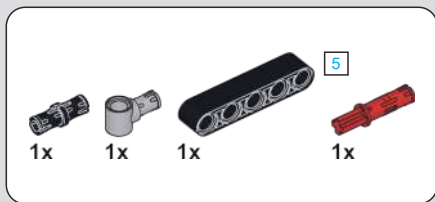

# 84

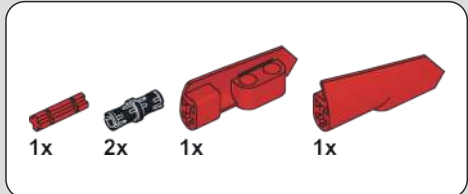
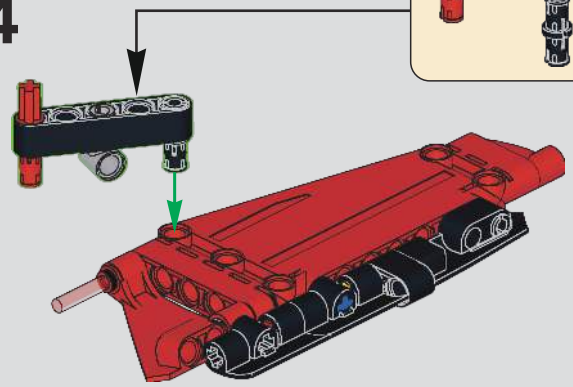
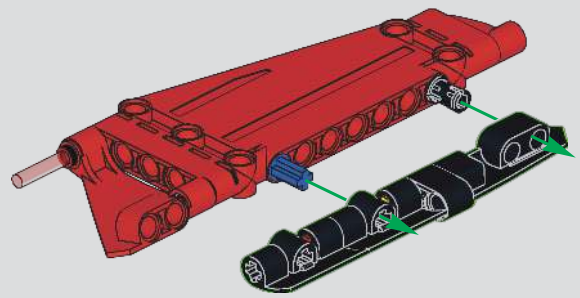

# 85

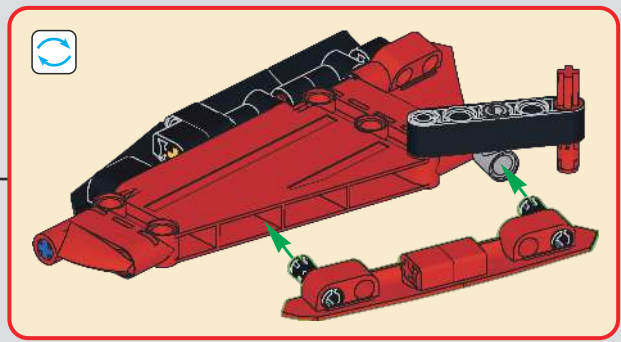
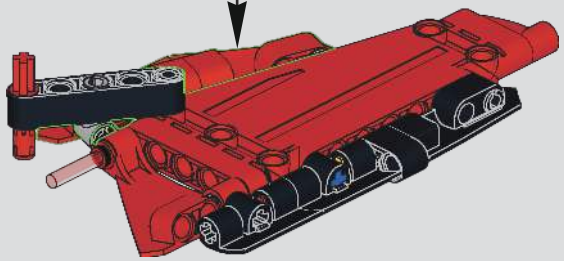
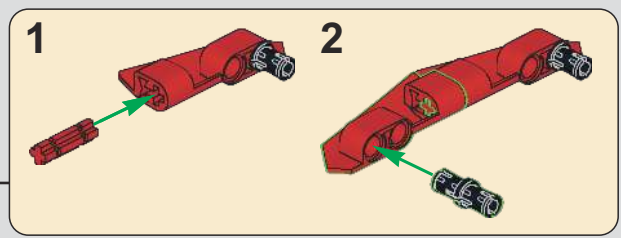

(Technic Pin without Friction)

(光滑栓)



1x



1x



1x



1x



1x

7

86

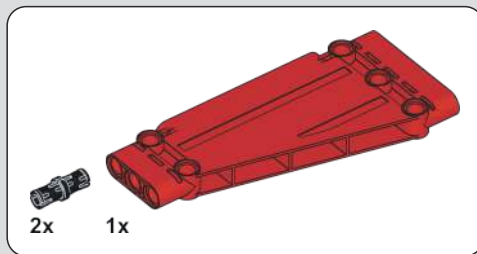
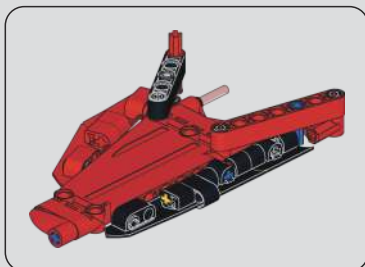
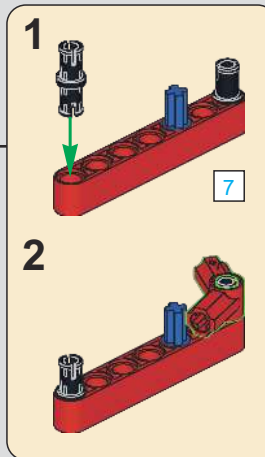
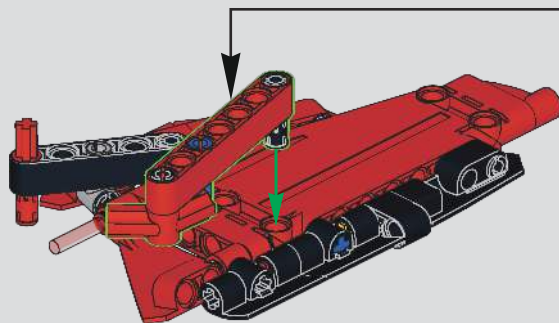

87

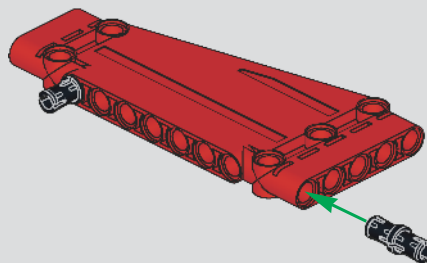
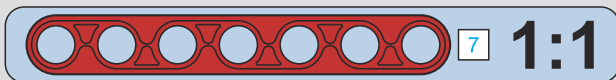
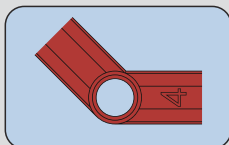

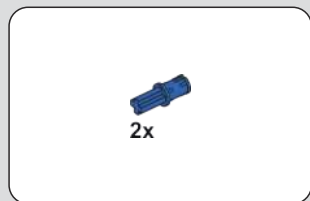

88

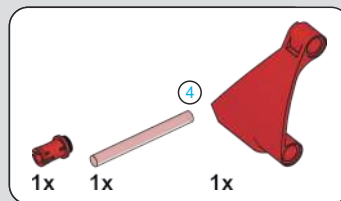
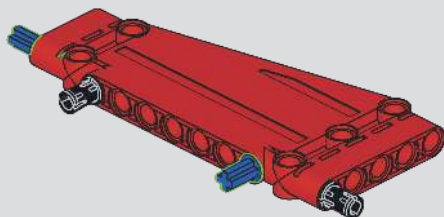

89

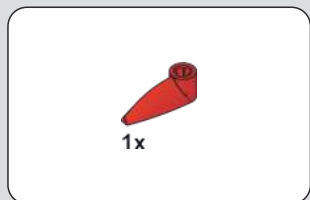
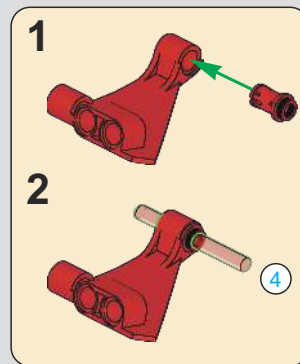
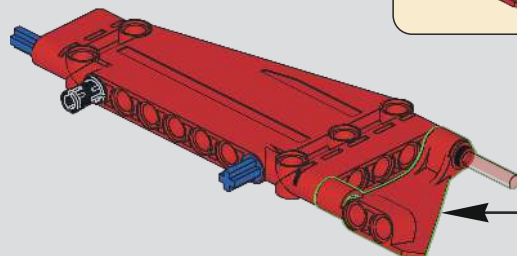

90

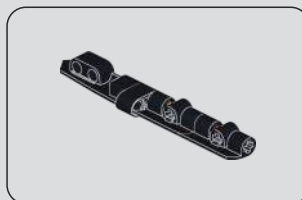
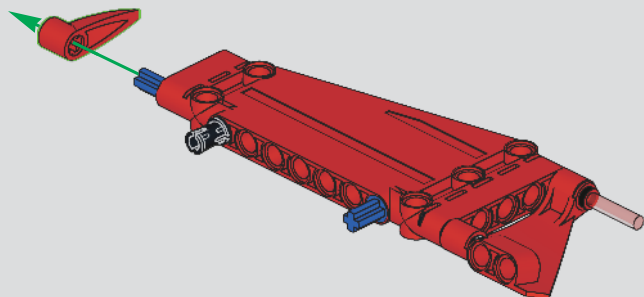

91

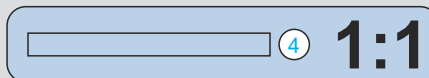
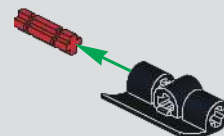

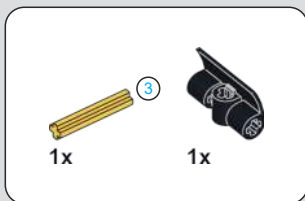

92

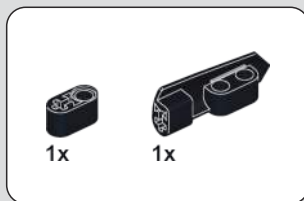

93

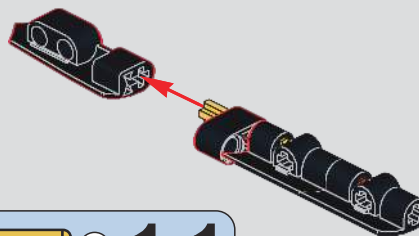
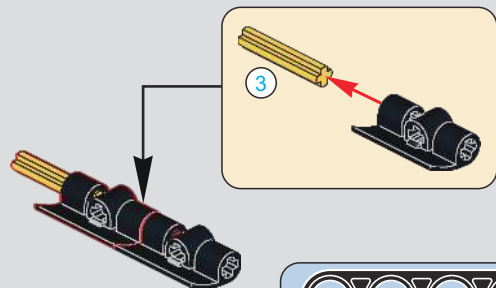

94

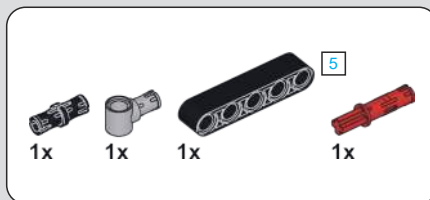

95

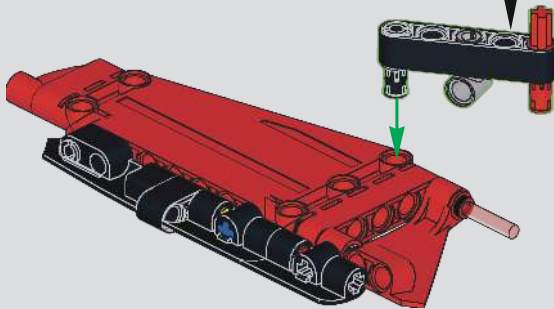
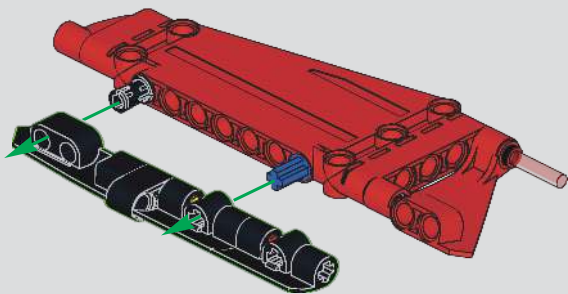
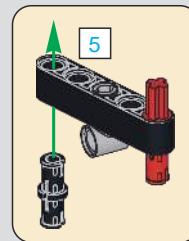

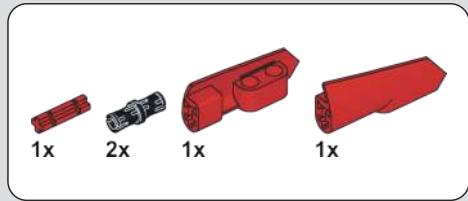

96

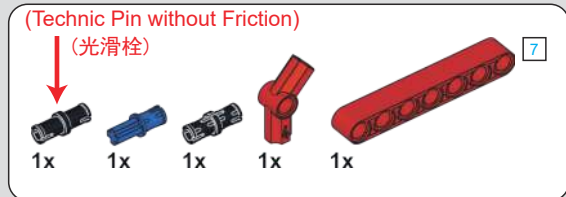
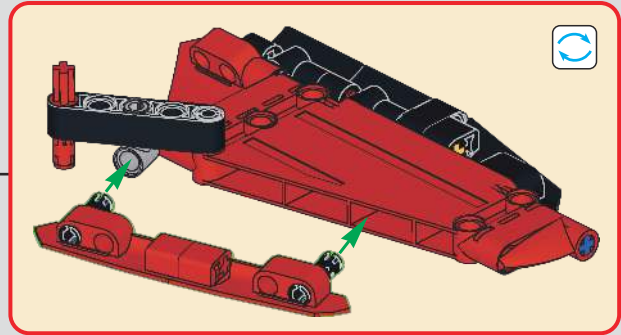
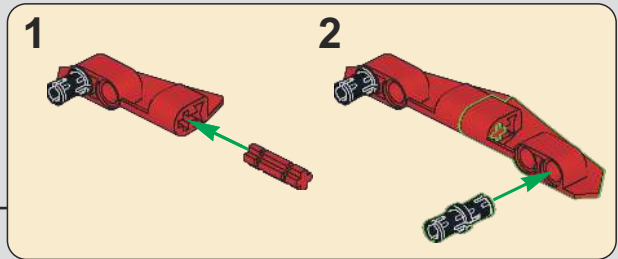
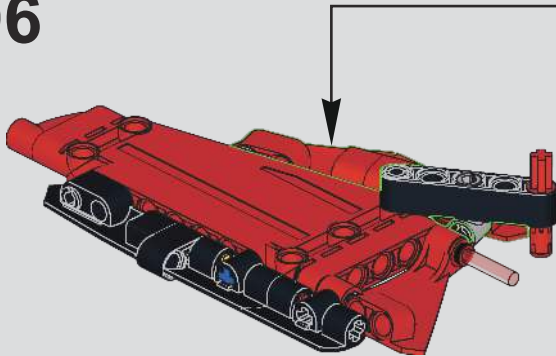

97

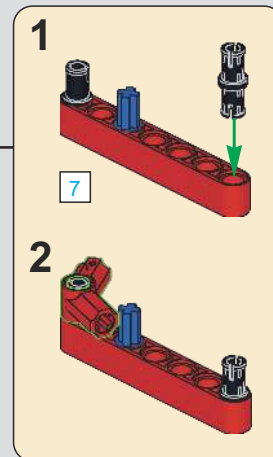
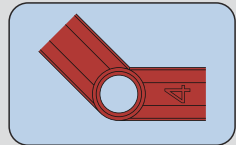
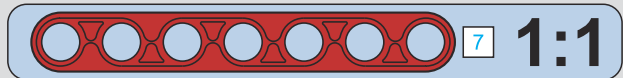
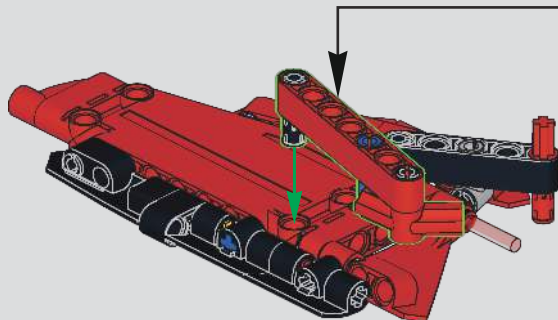

98

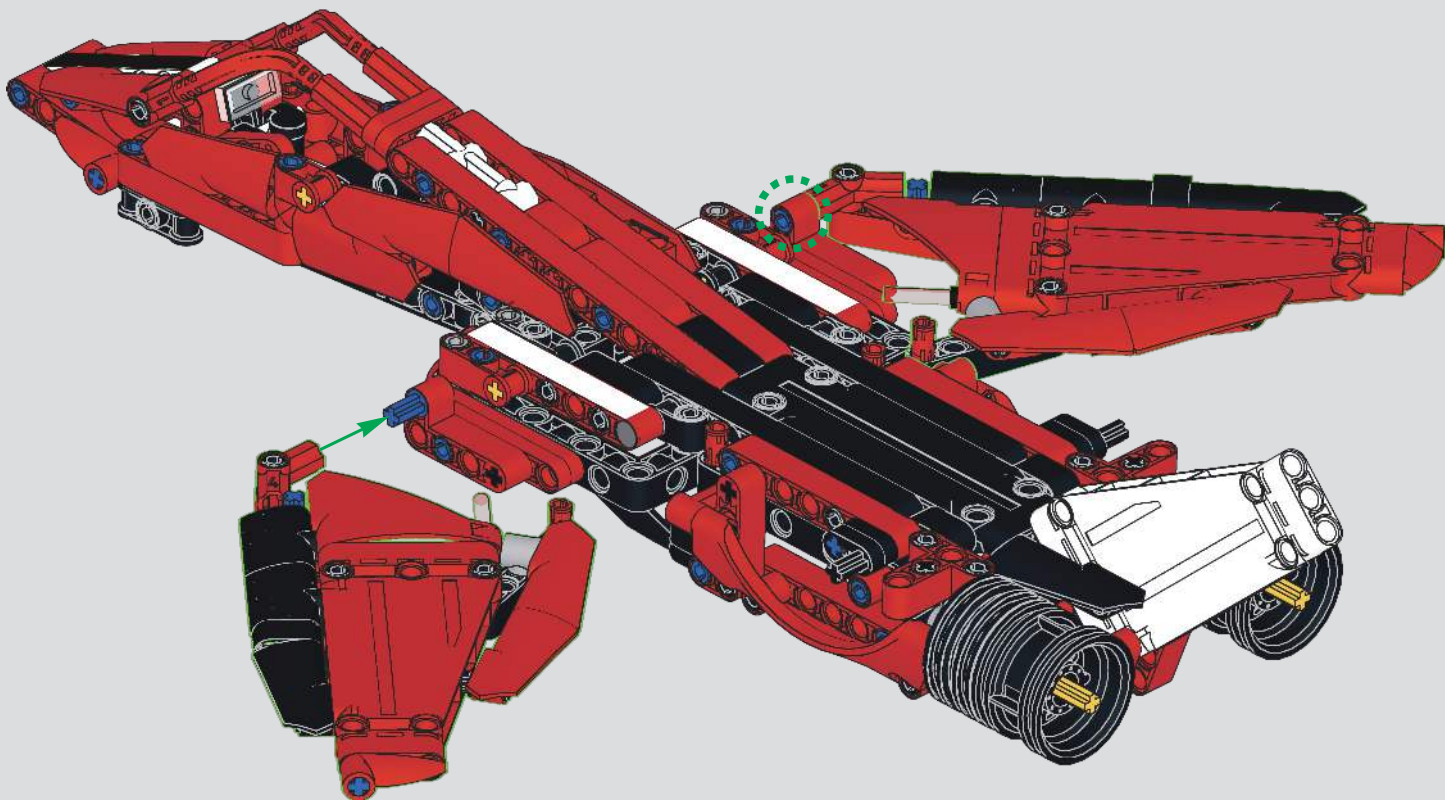

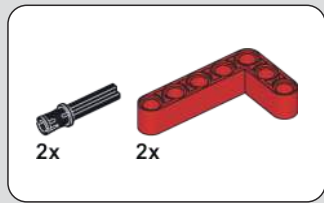

99

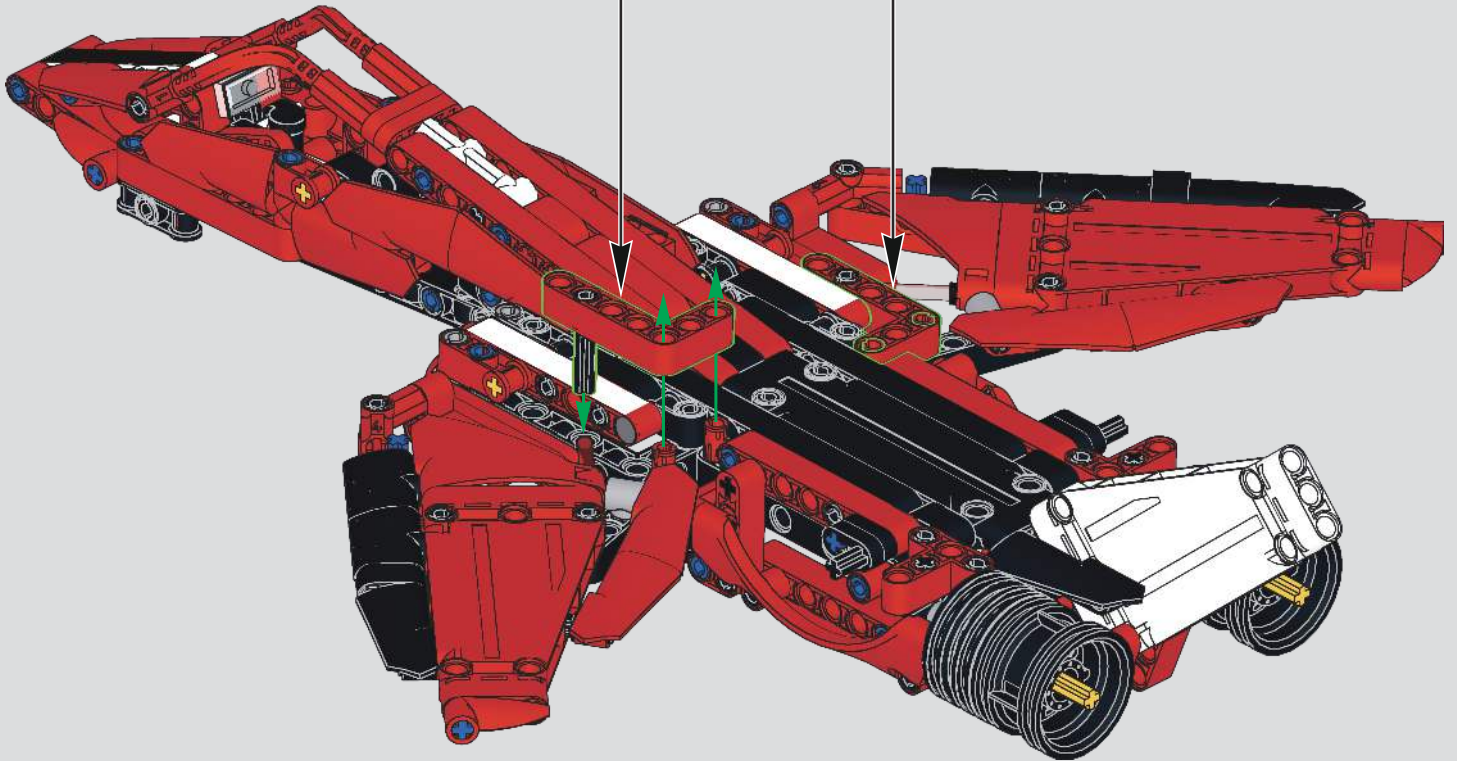
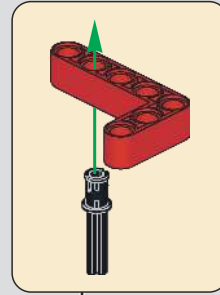
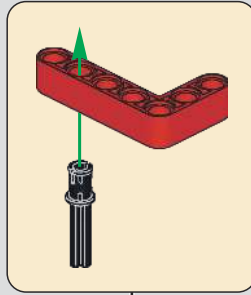

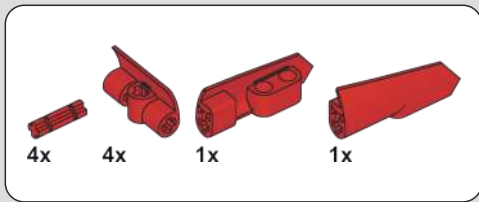

100

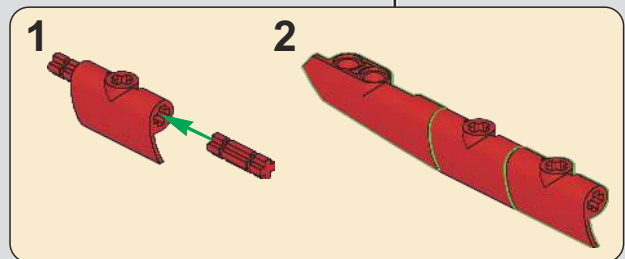
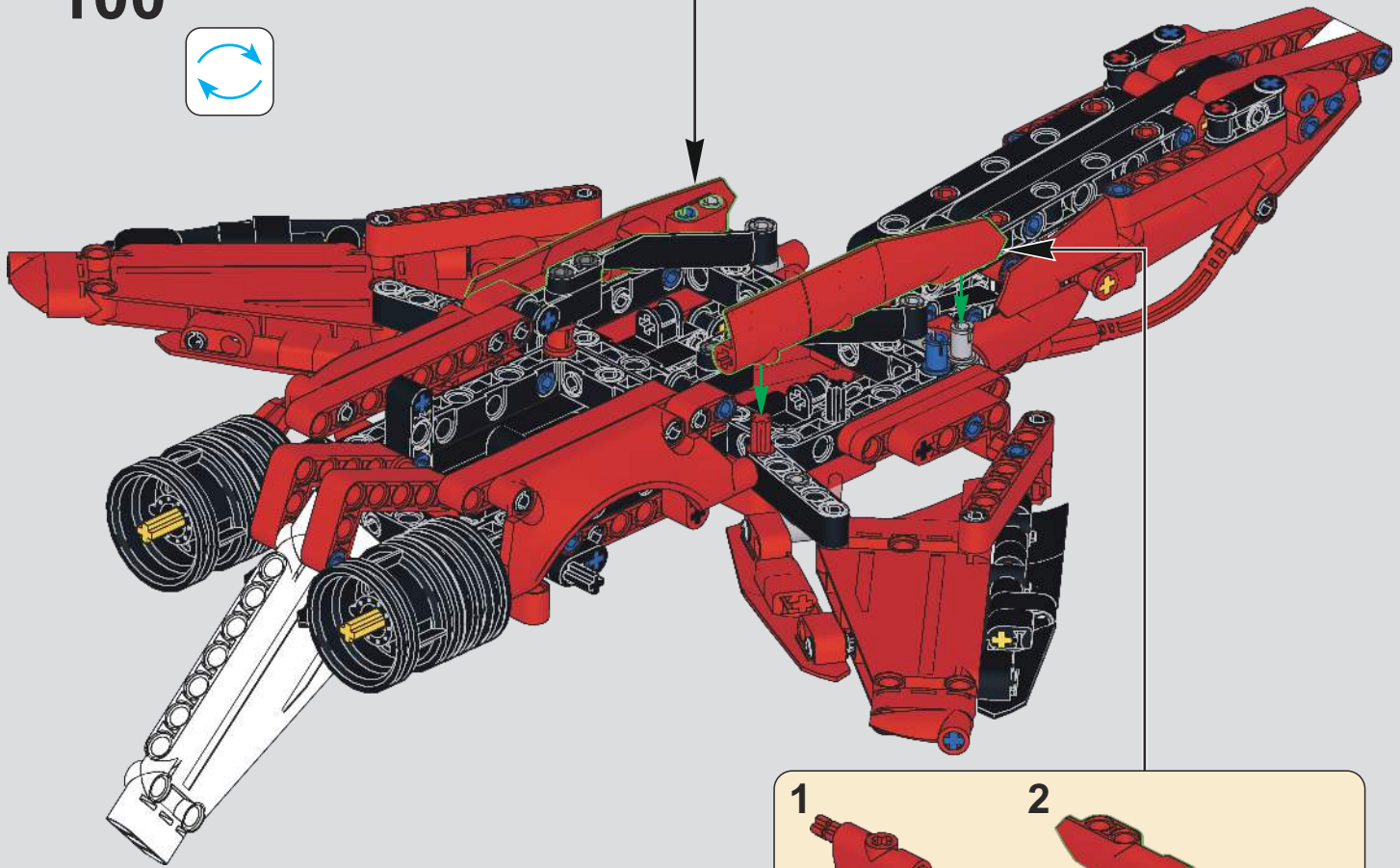
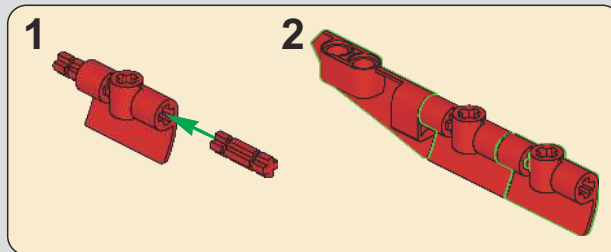

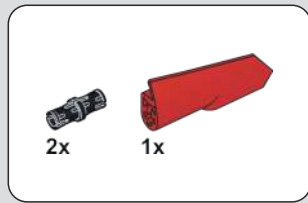
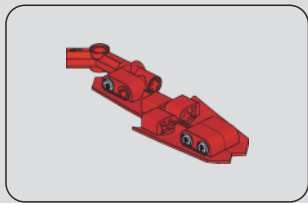

101

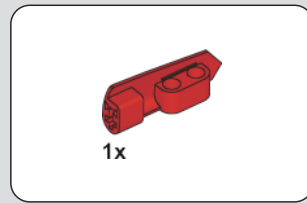

102

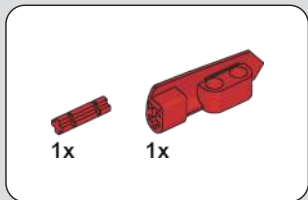
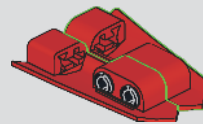
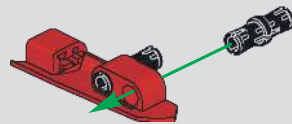
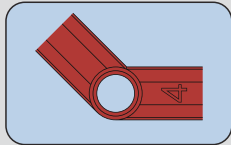

103



104

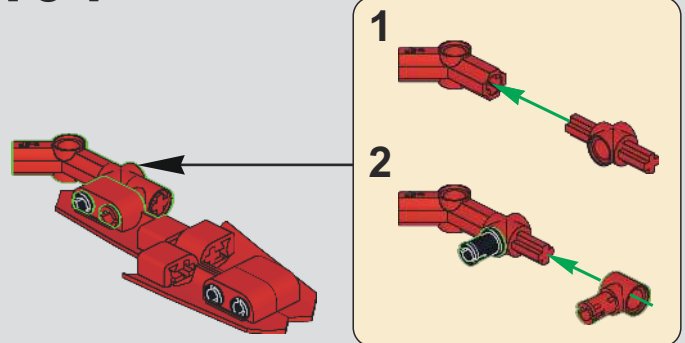
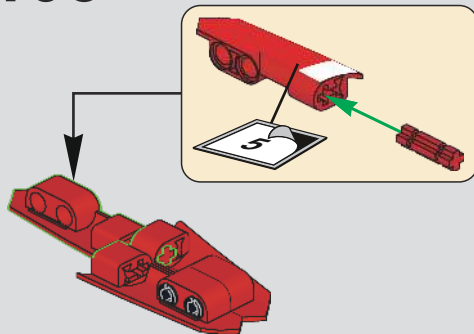

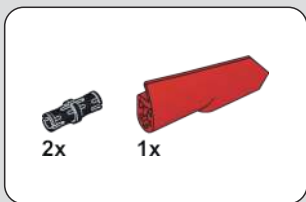
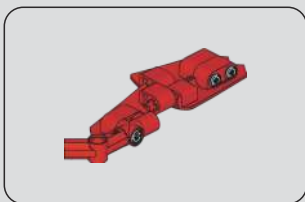

105

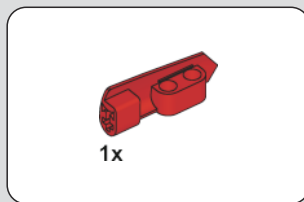

106

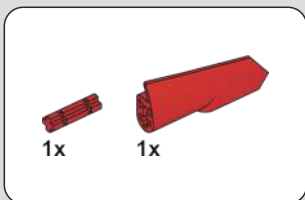
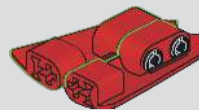
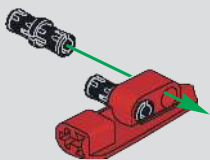
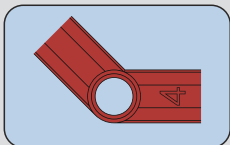

107



108

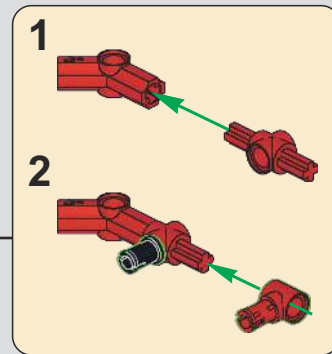
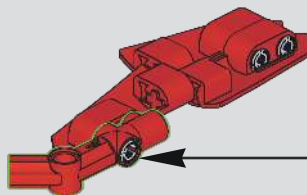
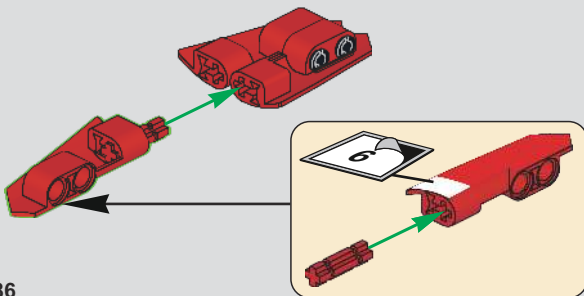

109

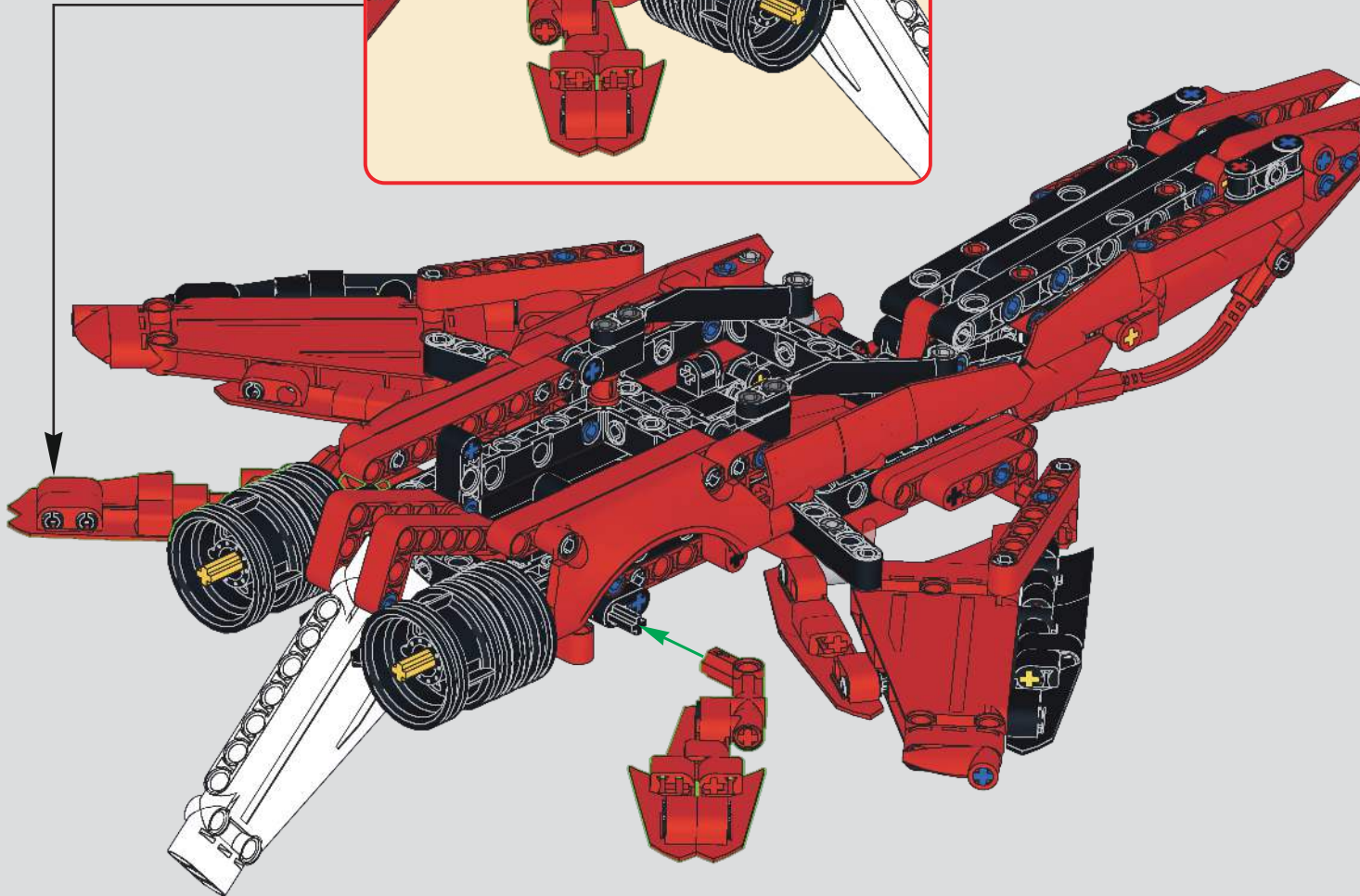
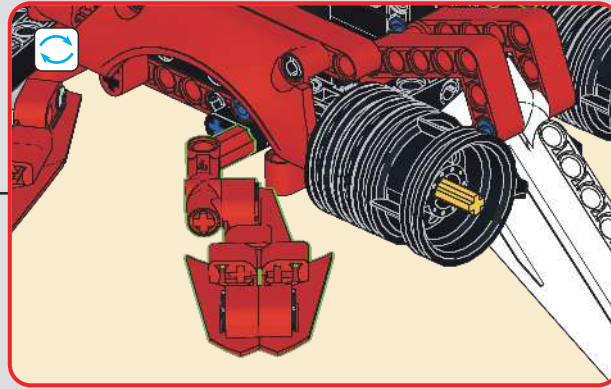

**MOULD  
KING**

®

宇 | 星 | 模 | 王

